



ERSATZTEILKATALOG



Replacement parts for

CASE IH



Bepco Group

Bepco House - Hartlebury Trading Estate
Worcestershire - DY104JB Hartlebury (UK)

Tel.: +(44) 12 99 25 2200
Fax: +(44) 12 99 25 2201

Bepco (U.K) Ltd.

Bepco House - Hartlebury Trading Estate
Worcestershire - DY104JB Hartlebury (UK)

Tel.: +(44) 12 99 25 2270
Fax: +(44) 800 21 6553



Tracpieces Benelux s.a.

Rue de Waremme, 114
B-4530 Villers-le-Bouillet (Belgique/België)

Tel.: +(32) 04 257 98 00
Fax: 0800 23 132



Tracpieces France s.a.

P.A. Fontaine Notre Dame
F-59406 Cambrai (France)

Tel.: +(33) 327 83 53 12
Fax: +(33) 327 81 23 13

Agripieces Sud-Ouest Distribution s.a.

Zone Industrielle Agen Boe, B.P. 5
F-47240 Bon-Encontre (France)

Tel.: +(33) 553 96 31 25
Fax: +(33) 553 68 03 72



Tracpieces Ersatzteile GmbH

Neuer Weg 5, Gewerbegebiet Lohner Klei
D-59505 Bad Sassendorf (Deutschland)

Tel.: +(49) 2927 919 59 0
Fax: +(49) 5251 919 59 59



Tracpieces Nederland b.v.

Den Dolvert, 10
NL-5473 GP Heeswijk-Dinther (Nederland)

Tel.: +(31) 413 293 975
Fax: +(31) 413 294 087



Europea de Recambios s.a.

Poligono Industrial Les Guixeres, C/. Xarol, 7
08915 - BADALONA (Barcelona)

Tel.: +(34) 93 381 00 62
Fax: +(34) 93 381 33 45



Bepco Australasia (Head office)

Factory 5, 1 Melverton Drive
Hallam 3803 Victoria (Australia)

Tel.: +(61) 397 96 54 22
Fax: +(61) 397 96 52 51



Bepco South Africa (Pty) Ltd.

CNR Rudo Nell / Kelly St.
Jet Park Boksburg, Johannesburg (South Africa)

Tel.: +(27) 11 3975386/9
Fax: +(27) 11 3973039

SCHNELL INDEX**I MOTORENTEILE** Seite 009-072

Kurbelwellen.....	009 - 021
Hauptlager & Pleullager.....	009 - 021
Kurbelwellenzubehör & Dichtungen.....	009 - 021
Starterkränze.....	009 - 021
Kolben, Buchsen, Ringe.....	022 - 044
Komplette Motorreparatursätze.....	029
Einzelteile zu Zylinderköpfen.....	045 - 055
Motordichtungen, Dichtungssätze.....	056 - 065
Dichtmittel Loctite®.....	066 - 067
Motorölpumpen.....	068 - 071
Einfülldeckel, Ablass-Schrauben, Peilstäbe.....	072

II KRAFTSTOFF Seite 073-078

Düsen & Düsendichtungen.....	073 - 075
Kraftstoffförderpumpen & Reparatursätze.....	076 - 077
Glühstart & Flammglühkerzen.....	078

III KÜHLUNG Seite 079-099

Wasserpumpen & Reparatursätze.....	079 - 082
Keilriemen.....	083 - 087
Spannrollen.....	087
Kühler.....	088 - 089
Kühlerdeckel.....	090
Lüfterflügel.....	090
Kühlerschläuche.....	091 - 095
Kühlerschläuche Meterware & Schlauchschellen.....	096
Wassersammelrohre.....	097
Thermostate & Dichtungen.....	098 - 099

IV BOWDENZÜGE Seite 100-103

Stoppzüge.....	100 - 101
Gaszüge.....	102 - 103



SCHNELLINDEX

V ABGASANLAGE Seite 105-108

Einlasskrümmer, Auslasskrümmer & Dichtungen.....	105 - 106
Schalldämpfer.....	107
Regenkappen, Funkenfänger & Schellen.....	108

VI FILTER Seite 109-139

Luft-, Motoröl- & Kraftstofffilter.....	109 - 132
Wasserfilter.....	129
Filtergläser.....	131
Hydraulikfilter.....	133 - 138
Kabinenfilter.....	139

VII ELEKTRIK Seite 143-164

Öldruckschalter.....	143
Temperaturgeber & Anzeigen.....	144
Sicherheitsschalter.....	145 - 147
Magnetschalter.....	148
Zündschlösser & Lichtschalter.....	149 - 150
Warnblinkschalter & Mehrfunktionsschalter.....	151 - 152
Blinkgeber.....	153
Diverse Schalter.....	154 - 155
Beleuchtung.....	156 - 164

VIII KUPPLUNG Seite 165-185

Kupplungsautomaten, -scheiben, Drucklager.....	165 - 179
Torsionsdämpfer.....	180
Kupplungsseile.....	181
Kupplungsgeber- & nehmerzylinder.....	182
Zapfwellenkupplungsteile.....	183 - 185



SCHNELL INDEX**IX BREMSANLAGE** Seite 186-193

Trommelbremse.....	186
Kardanbremse.....	187
Ölbadbremse.....	187 - 189
Handbremse.....	190
Bremszylinder.....	191 - 192
Bowdenzüge.....	193

X HINTERACHSE Seite 194

Diverse Einzelteile.....	194
--------------------------	-----

XI VORDERACHSTEILE, LENKUNG Seite 195-257

Vorderachsteile 2WD.....	195 - 201
Allradachsenteile ZF.....	202 - 225
Allradachsenteile Carraro.....	226 - 240
Antriebswellen & Einzelteile.....	241 - 242
Gelenkkreuze.....	243
Kugelköpfe & Axialgelenke.....	244 - 256
Lenkzylinder & Einzelteile.....	256 - 257

XII HYDRAULIK Seite 258-267

Hydraulikpumpen.....	258 - 261
Lenkorbitrole.....	262
Vollhydraulische Lenkungen & Hubkraftverstärkungen..	262 - 263
Steuergeräte.....	264 - 266
Hydraulikkupplungen.....	267

XIII DREIPUNKTTEILE Seite 268-277

Unterlenkerwelle.....	268 - 269
Hubwerk.....	270
Oberlenker & Stabilisatoren.....	271 - 274
Hubstangen.....	275 - 277



SCHNELLINDEX**XIV ANLASSER & LICHTMASCHINEN** Seite 278-291

Anlasser & Einzelteile.....	278 - 285
Lichtmaschinen & Einzelteile.....	286 - 291

XV KLIMAAANLAGE Seite 292-294

Kompressoren & Kondensatoren.....	292
Filtertrockner.....	293
Thermostate & Expansionsventile.....	294

XVI KAROSSERIE & KABINE Seite 295-329

Schutzbleche & Verkleidungen.....	295 - 296
Typenschilder & Aufklebersätze.....	297
Sitze.....	298
Gasfedern.....	299 - 301
Lacke & Zubehör.....	302 - 304
Wischermotoren & Wischerblätter.....	305 - 306
Griffe & Schlösser.....	307 - 308
Spiegel & Zubehör.....	309 - 311
Kabinendämpfer.....	312
Kabinenscheiben.....	313 - 329



VERGLEICHSLISTE TRAKTOREN & MOTOREN

Schleppertyp	Motoren		Zyl.	Bohrung	Schleppertyp	Motoren		Zyl.	Bohrung
	Hersteller	Typ				Hersteller	Typ		
B275	IH	BD144	4	85.70	824	IH	D246	4	100.00
B414	IH	BD154	4	88.90	833	IH	D239	4	98.40
D212	IH	D66	2	82.55	840	IH	D239	4	98.40
D214	IH	D66	2	82.55	844	IH	D246	4	100.00
D215	IH	D66	2	82.55	844S	IH	D268	4	100.00
D217	IH	D74	2	87.30	845	IH	D268	4	100.00
D219	IH	D74	2	87.30	856	IH	DT239	4	98.40
D320	IH	D99	3	82.55	884	IH	D268	4	100.00
D322	IH	D99	3	82.55	885	IH	D268	4	100.00
D324	IH	D111	3	87.30	886	IH	D360	6	
D326	IH	D111	3	87.30	895	IH	D268	4	100.00
D430	IH	D132	4	82.55	940	IH	D239	4	98.40
D432	IH	D132	4	82.55	946	IH	D310	6	98.40
D436	IH	D148	4	87.30	955	IH	D310	6	98.40
D438	IH	D148	4	87.30	956	IH	D358	6	98.40
D439	IH	D148	4	87.30	966	IH	D414	6	
238	IH	BD154	4	88.90	986	IH	D436	6	
248	IH	D179	3	98.40	995	IH	DT268	4	100.00
276	IH	BD144	4	85.70	1026	IH	D407	6	
278	IH	D246	4	100.00	1046	IH	D358	6	98.40
323	IH	D111	3	87.30	1055	IH	D358	6	98.40
353	IH	D155	3	98.40	1056	IH	D358	6	98.40
354	IH	BD144	4	85.70	1066	IH	DT414	6	
374	IH	BD154	4	88.90	1070	IH	451B	6	107.47
383	IH	D155	3	98.40	1086	IH	DT414	6	
384	IH	BD154	4	88.90	1090	IH	451B	6	107.47
385	IH	D155	3	98.40	1170	IH	451B	6	107.47
395	IH	D155	3	98.40	1175	IH	451BDT	6	107.47
423	IH	D155	3	98.40	1206	IH	DT361	6	
424	IH	BD154	4	88.90	1246	IH	DT358	6	98.40
433	IH	D155	3	98.40	1255	IH	DT358	6	98.40
434	IH	BD154	4	88.90	1256	IH	D407	6	
440	IH	D155	3	98.40	1270	IH	451BDT	6	107.47
444	IH	BD154	4	88.90	1370	IH	504BDT	6	107.47
453	IH	D155	3	98.40	1455	IH	DT402	6	100.00
454	IH	D179	3	98.40	1456	IH	D407	6	
464	IH	D179	3	98.40	1466	IH	DT436	6	
474	IH	D206	4	98.40	1486	IH	DT436	6	
475	PERKINS	A4.212	4	98.48	1566	IH	DT436	6	
484	IH	D179	3	98.40	1570	IH	504BDT	6	107.47
485	IH	D179	3	98.40	1586	IH	DT436	6	
495	IH	D179	3	98.40	1896	CUMMINS	6T590	6	102.00
523	IH	D179	3	98.40	2090	IH	504BD	6	107.47
533	IH	D155	3	98.40	2094	IH	504BD	6	107.47
540	IH	D155	3	98.40	2096	CUMMINS	6TA590	6	102.00
553	IH	D179	3	98.40	2120	SAME	1000.3A	3	105.00
574	IH	D239	4	98.40	2130	SAME	1000.3A	3	105.00
584	IH	D206	4	98.40	2140	SAME	1000.4A	4	105.00
585	IH	D206	4	98.40	2150	SAME	1000.4A	4	105.00
595	IH	D206	4	98.40	2290	IH	504BDT	6	107.47
633	IH	D179	3	98.40	2294	IH	504BDT	6	107.47
640	IH	D179	3	98.40	2390	IH	504BDT	6	107.47
644	IH	D206	4	98.40	2394	IH	504BDT	6	107.47
645	IH	D206	4	98.40	2400	IH	D179	3	98.40
654	IH	D206	4	98.40	2470	IH	504BDT	6	107.47
674	IH	D239	4	98.40	2590	IH	504BDT	6	107.47
684	IH	D239	4	98.40	2594	IH	504BDT	6	107.47
685	IH	D239	4	98.40	2670	IH	504BDT	6	107.47
695	IH	D239	4	98.40	3210	IH	D155	3	98.40
724	IH	D239	4	98.40	3220	IH	D179	3	98.40
733	IH	D206	4	98.40	3230	IH	D206	4	98.40
740	IH	D206	4	98.40	3294	IH	504BDT	6	107.47
743	IH	D239	4	98.40	3388	IH	DT436	6	
744	IH	D239	4	98.40	3394	IH	504BDT	6	107.47
745	IH	D239	4	98.40	3488	IH	D466	6	
766	IH	D360	6		3594	IH	504BDT	6	107.47
784	IH	D246	4	100.00	3688	IH	D436	6	
785	IH	D246	4	100.00	4100	IH	DT429	6	
795	IH	D246	4	100.00					

Wir vertreiben keine Originalteile.

Die Nummern dienen lediglich als Beschreibung.

"THE RELIABLE SERVICE"

VERGLEICHSLISTE TRAKTOREN & MOTOREN

Schleppertyp	Motoren		Zyl.	Bohrung	Schleppertyp	Motoren		Zyl.	Bohrung
	Hersteller	Typ				Hersteller	Typ		
4156	IH	DT429	6		CS48	PERKINS	903.27	3	95.00
4166	IH	DT436	6		CS52	PERKINS	903.27	3	95.00
4186	IH	DT436	6		CS58	PERKINS	903.27T	3	95.00
4210	IH	D239	4	98.40	CS63	PERKINS	903.27T	3	95.00
4220	IH	D246	4	100.00	CS68 (⇒ 12/98)	MWM	TD 226-B 3	3	105.00
4230	IH	D268	4	100.00	CS68 (01/99 ⇒)	SISU	320D	3	108.00
4240	IH	DT268	4	100.00	CS75 (⇒ 12/98)	MWM	TD 226-B 3	3	105.00
4490	IH	504BDT	6	107.47	CS75 (01/99 ⇒)	SISU	320D	3	108.00
4494	IH	504BDTI	6	107.47	CS78 (⇒ 12/98)	MWM	TD 226-B 4	4	105.00
4690	IH	504BDTI	6	107.47	CS78 (01/99 ⇒)	SISU	420D	4	108.00
4694	IH	504BDTI	6	107.47	CS86 (⇒ 12/98)	MWM	TD 226-B 4	4	105.00
5088	IH	DT436	6		CS86 (01/99 ⇒)	SISU	420D	4	108.00
5120	CUMMINS	4T390	4	102.00	CS94 (⇒ 12/98)	MWM	TD 226-B 4	4	105.00
5130	CUMMINS	6-590	6	102.00	CS94 (01/99 ⇒)	SISU	420D	4	108.00
5140	CUMMINS	6T590	6	102.00	CS100	SISU	420D	4	108.00
5150	CUMMINS	6T590	6	102.00	CS110	SISU	420D	4	108.00
5220	CUMMINS	4T390	4	102.00	CS120	SISU	620D	6	108.00
5230	CUMMINS	6-590	6	102.00	CS130	SISU	620D	6	108.00
5240	CUMMINS	6T590	6	102.00	CS150	SISU	620D	6	108.00
5250	CUMMINS	6T590	6	102.00	CVX120	SISU	620D	6	108.00
7110	CUMMINS	6T830	6	114.00	CVX130	SISU	620D	6	108.00
7120	CUMMINS	6T830	6	114.00	CVX150	SISU	620D	6	108.00
7130	CUMMINS	6T830	6	114.00	CVX170	SISU	620D	6	108.00
7140	CUMMINS	6T830	6	114.00	CVX1135	SISU	620D	6	108.00
7150	CUMMINS	6T830	6	114.00	CVX1145	SISU	620D	6	108.00
7210	CUMMINS	6T830	6	114.00	CVX1155	SISU	620D	6	108.00
7220	CUMMINS	6T830	6	114.00	CVX1170	SISU	620D	6	108.00
7230	CUMMINS	6T830	6	114.00	CVX1190	SISU	620D	6	108.00
7240	CUMMINS	6T830	6	114.00	CX50	PERKINS	903.27	3	95.00
7250	CUMMINS	6T830	6	114.00	CX60	PERKINS	903.27T	3	95.00
8910	CUMMINS	6T830	6	114.00	CX70	PERKINS	1004.4T	4	100.00
8920	CUMMINS	6T830	6	114.00	CX80	PERKINS	1004.4T	4	100.00
8930	CUMMINS	6T830	6	114.00	CX90	PERKINS	1004.4T	4	100.00
8940	CUMMINS	6T830	6	114.00	CX100	PERKINS	1004.4T	4	100.00
8950	CUMMINS	6T830	6	114.00	JX55	IVECO	8035.06	3	100.00
9110	CUMMINS	6T830	6	114.00	JX60	IVECO	8035.05	3	104.00
9130	CUMMINS	6T830	6	114.00	JX65	IVECO	8035.05	3	104.00
9150	CUMMINS	LTA-10	6	125.00	JX70	IVECO	8035.05	3	104.00
9170	CUMMINS	NTA855	6	140.00	JX70U	IVECO	8045.06	4	100.00
9180	CUMMINS	NTA855	6	140.00	JX75	IVECO	8045.06	4	100.00
9210	CUMMINS	6T830	6	114.00	JX80	IVECO	8045.05	4	104.00
9230	CUMMINS	6T830	6	114.00	JX80U	IVECO	8045.05	4	104.00
9240	CUMMINS	6T830	6	114.00	JX85	IVECO	8045.05	4	104.00
9250	CUMMINS	LTA-10	6	125.00	JX90	IVECO	8045.05	4	104.00
9260	CUMMINS	LTA-10	6	125.00	JX90U	IVECO	8045.05	4	104.00
9270	CUMMINS	NTA855	6	140.00	JX95	IVECO	8045.05	4	104.00
9280	CUMMINS	NTA855	6	140.00	JX100U	IVECO	8045.05	4	104.00
9310	CUMMINS	6T830	6	114.00	JX1060C	IVECO	8045.05	4	104.00
9330	CUMMINS	6T830	6	114.00	JX1070C	IVECO	8035.05	3	104.00
9350	CUMMINS	LTA-10	6	125.00	JX1070U	IVECO		4	
9370	CUMMINS	NTA855	6	140.00	JX1075C	IVECO	8035.05	3	104.00
9380	CUMMINS	NTA855	6	140.00	JX1080U	IVECO		4	
9390	CUMMINS	NTA855	6	140.00	JX1085C				
AVJ55	IVECO	8035.06	3	100.00	JX1090U			4	
AVJ60	IVECO	8035.05	3	104.00	JX1095C				
AVJ70	IVECO	8045.06	4	100.00	JX1100U			4	
C42	STEYR	WD308	3	100.00	MX80C	PERKINS	1004.4T	4	100.00
C48	STEYR	WD308	3	100.00	MX90C	PERKINS	1004.4T	4	100.00
C50	PERKINS	903.27	3	95.00	MX100C	PERKINS	1004.4T	4	100.00
C55	MWM	TD 226-B 3	3	105.00	MX100	CUMMINS	6T590	6	102.00
C55A	MWM	TD 226-B 3	3	105.00	MX110	CUMMINS	6T590	6	102.00
C60	PERKINS	903.27T	3	95.00	MX120	CUMMINS	6T590	6	102.00
C64	MWM	TD 226-B 3	3	105.00	MX135	CUMMINS	6T590	6	102.00
C64A	MWM	TD 226-B 3	3	105.00	MX150	CUMMINS	6T590	6	102.00
C70	PERKINS	1004.4T	4	100.00	MX170	CUMMINS	6T590	6	102.00
C70A	MWM	TD 226-B 3	3	105.00	MX180	CUMMINS	6T830	6	114.00
C80	PERKINS	1004.4T	4	100.00	MX200	CUMMINS	6T830	6	114.00
C90	PERKINS	1004.4T	4	100.00	MX210	CUMMINS	6T830	6	114.00

Wir vertreiben keine Originalteile.
 Die Nummern dienen lediglich als Beschreibung.



"THE RELIABLE SERVICE"



VERGLEICHSLISTE TRAKTOREN & MOTOREN

Schleppertyp	Motoren		Zyl.	Bohrung	Schleppertyp	Motoren		Zyl.	Bohrung
	Hersteller	Typ				Hersteller	Typ		
MX220	CUMMINS	6T830	6	114.00	PJN55	SAME	1000.3A	3	105.00
MX230	CUMMINS	6T830	6	114.00	PJN65	SAME	1000.4A	4	105.00
MX240	CUMMINS	6T830	6	114.00	PJN75	SAME	1000.4A	4	105.00
MX255	CUMMINS	6T830	6	114.00	PJV55	SAME	1000.3A	3	105.00
MX270	CUMMINS	6T830	6	114.00	PJV65	SAME	1000.4A	4	105.00
MX285	CUMMINS	6T830	6	114.00	PJV75	SAME	1000.4A	4	105.00
MXM120	FORD	675/TA	6	111.76	STX275	CNH		6	
MXM130	FORD	675/TA	6	111.76	STX325	CNH			
MXM135					STX375	CUMMINS			
MXM140	FORD	675/TA	6	111.76	STX425	CUMMINS			
MXM150					STX440	CUMMINS			
MXM155	FORD	675/TA	6	111.76	STX450	CUMMINS			
MXM165					STX500	CUMMINS			
MXM175	FORD	675/TA	6	111.76	VJ60	IVECO	8035.05	3	104.00
MXM180					VJ70	IVECO	8045.06	4	100.00
MXM190	FORD	675/TA	6	111.76	VJ80	IVECO	8045.05	4	104.00
MXU100	CNH		4						
MXU110	CNH		4						
MXU115	CNH		4						
MXU125	CNH		4						
MXU135	CNH		4						
PJ55	SAME	1000.3A	3	105.00					
PJ65	SAME	1000.4A	4	105.00					
PJ75	SAME	1000.4A	4	105.00					

VERGLEICHSLISTE MOTOREN & TRAKTOREN

Motor	Schleppertyp
IH	
451B	1070, 1090, 1170
451BDT	1175, 1270
504BD	2090, 2094
504BDT	1370, 1570, 2290, 2294, 2390, 2394, 2470, 2590, 2594, 2670, 3294, 4490
504BDTI	4494, 4690, 4694
BD144	276, 354, B275
BD154	238, 374, 384, 424, 434, 444, B414
D66	D212, D214, D215
D74	D217, D219
D99	D320, D322
D111	D324, D326, 323
D132	D430, D432
D148	D436, D438, D439
D155	353, 383, 385, 395, 423, 433, 440, 453, 533, 540, 3210
D179	248, 454, 464, 484, 485, 495, 523, 553, 633, 640, 2400, 3220
D206	474, 584, 585, 595, 644, 645, 654, 733, 740, 3230
D239	574, 674, 684, 685, 695, 724, 743, 744, 745, 833, 840, 940, 4210
D246	278, 784, 785, 795, 824, 844, 4220
D268	844S, 845, 884, 885, 895, 4230
D310	946, 955
D358	956, 1046, 1055, 1056
D360	766, 886
D407	1026, 1256, 1456
D414	966
D436	986, 3688
D466	3488
DT239	856
DT268	995, 4240
DT358	1246, 1255
DT361	1206
DT402	1455
DT414	1066, 1086
DT429	4100, 4156
DT436	1466, 1486, 1566, 1586, 3388, 4166, 4186, 5088

Wir vertreiben keine Originalteile.
 Die Nummern dienen lediglich als Beschreibung.

"THE RELIABLE SERVICE"

VERGLEICHSLISTE MOTOREN & TRAKTOREN

Motor	Schleppertyp
CUMMINS	
4T390	5120, 5220
6-590	5130, 5230
6T590	1896, 5140, 5150, 5240, 5250, MX100, MX110, MX120, MX135, MX150, MX170
6T830	7110, 7120, 7130, 7140, 7150, 7210, 7220, 7230, 7240, 7250, 8910, 8920, 8930, 8940, 8950, 9110, 9130, 9210, 9230, 9240, 9310, 9330, MX180, MX200, MX210, MX220, MX230, MX240, MX255, MX270, MX285
6TA590	2096
LTA-10	9250, 9250, 9260, 9350
NTA855	9170, 9180, 9270, 9280, 9370, 9380, 9390
MWM	
TD 226-B 3	C55, C55A, C64, C64A, C70A - CS68, CS75 (⇒ 12/98)
TD 226-B 4	CS78, CS86, CS94 (⇒ 12/98)
SISU	
320D	CS68, CS75 (01/99 ⇒)
420D	CS78, CS86, CS94 (01/99 ⇒) - CS100, CS110
620D	CS120, CS130, CS150, CVX120, CVX130, CVX150, CVX170, CVX1135, CVX1145, CVX1155, CVX1170, CVX1190
PERKINS	
903.27	C50, CS48, CS52
903.27T	C60, CS58, CS63, CX60
1004.4T	C70, C80, C90, CX70, CX80, CX90, CX100, MX80C, MX90C, MX100C
A4.212	475
IVECO	
8035.05	AVJ60, JX60, JX65, JX70, JX1070C, JX1075C, VJ60
8035.06	AVJ55, JX55
8045.05	JX80, JX80U, JX85, JX90, JX90U, JX95, JX100U, JX1060C, VJ80
8045.06	AJV70, JX70U, JX75, VJ70
FORD	
675/TA	MXM120, MXM130, MXM140, MXM155, MXM175, MXM190
SAME	
1000.3A	2120, 2130, PJ55, PJN55, PJV55
1000.4A	2140, 2150, PJ65, PJN65, PJV65, PJ75, PJN75, PJV75
CNH	
	MXU100, MXU110, MXU115, MXU125, MXU135 STX275, STX325

Wir vertreiben keine Originalteile.
 Die Nummern dienen lediglich als Beschreibung.



"THE RELIABLE SERVICE"



KURBELWELLEN & EINZELTEILE

Motoren IH - Alte Serie



1	2	3	4	5	6	7	Motor	Schleppertyp
Hauptlager	Passlager	Pleuellager	Pleuelbuchsen	Pleuelschrauben	Wellendichtring vorne	Wellendichtring hinten		
Motoren 2 Zyl.								
25/7-16 (3064523R12, 710318R21) Paar	25/8-16 (711073R21, 711073R31)	25/9-16 (710327R11) Paar	25/28-12 (711045R1, 3043611R1)	25/26-16 (3051413R1)	25/11-116 45x60x10 (712219R91)	25/13-116 (712209R2)	D66	D212, D214, D215
							D74	D217, D219
Motoren 3 Zyl.								
25/7-16 (3064523R12, 710318R21) Paar	25/8-16 (711073R21, 711073R31)	25/9-16 (710327R11) Paar	25/28-12 (711045R1, 3043611R1)	25/26-16 (3051413R1)	25/11-117 (44695DA)	25/13-116 (712209R2)	D99	D320, D322
							D111	D324, D326, 323
Motoren 4 Zyl.								
25/7-16 (3064523R12, 710318R21) Paar	25/8-16 (711073R21, 711073R31)	25/9-16 (710327R11) Paar	25/28-12 (711045R1, 3043611R1)	25/26-16 (3051413R1)	25/11-117 (44695DA)	25/13-116 (712209R2)	D132	D430, D432, D440
							D148	D436, D438, D439

Vergleichsliste für Untermaß Hauptlager

Vergleichsliste für Untermaß Pleuellager

Standard	0.25mm	0.50mm	0.75mm	Standard	0.25mm	0.50mm	0.75mm
25/7-16	25/7-16 A	25/7-16 B	25/7-16 C	25/9-16	25/9-16 A	25/9-16 B	25/9-16 C
25/8-16	25/8-16 A	25/8-16 B	25/8-16 C				

Bestell-Nr.	Beschreibung	Schleppertyp	OEM	Abb.
25/17-116	Kurbelwellengehäusedichtung	D212, D214, D215, D217F, D217S, D219, DLD-2, D320, D322, D324, D326, 323	711058R2	
25/17-117	Deckeldichtung Kurbelw. hinten		712537R2	
25/17-118	Gummikeil		714868R1	

STARTERKRANZ

Bestell-Nr.	Beschreibung	Schleppertyp	OEM	Abb.
25/15-33	117Z Ø 358/323 mm	DLD2, D212, D214, D215, D217F, D217S, D219, DED3, D320, D322, D324, D326, DGD4, D430, D432, D436, D439, D440	711072R1	

Wir vertreiben keine Originalteile.
Die Nummern dienen lediglich als Beschreibung.



"THE RELIABLE SERVICE"

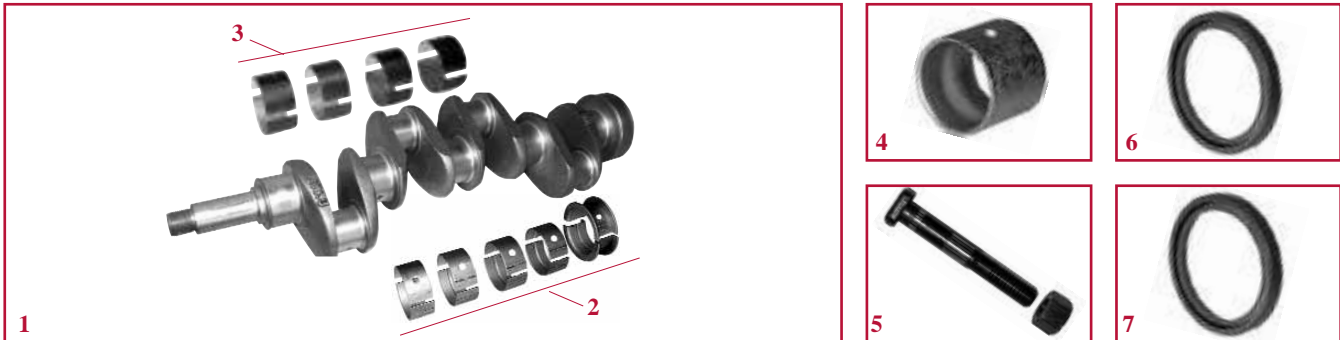

KURBELWELLEN & EINZELTEILE
Motoren IH

1	2	3	4	5	6	7	Motor	Schleppertyp
Kurbelwellensatz	Hauptlager	Pleuellager	Pleuelbuchsen	Pleuelschrauben	Wellendichring vorne	Wellendichring hinten		
Motoren 3 Zyl.								
	25/2-23 (1x3055129R21 3x3055130R21)	25/3-23 (3x3055351R91)	25/28-14 (3132018R2)	25/26-24 (3055033R1 + 3055034R1)	25/11-18 (A) (3228401R91)	25/13-16 (3138701R91)	D155	353, 383, 385, 395, 423, 433, 440, 453, 533, 540, 3210
							D179	248, 454, 464, 484, 485, 495, 523, 553, 633, 640, 2400, 3220
Motoren 4 Zyl.								
25/1-54 (751303R51, 3110995R91)	25/2-21 (708912R91, 1x708910R91 4x3064523R11)	25/3-21 (3070546R91, 4x3070536R11)	25/28-12 (711045R1, 3043611R1)		25/11-16 (3108650R91)	25/13-14 (3072092R91)	BD144	B275, 276, 354
							BD154	238, 374, 384, B414, 424, 434, 444
25/1-55 (1329196C1, 3132968R93)							D206	474, 584, 585, 595, 624, 644, 645, 654, 733, 740, 3230
25/1-56 (3144626R92)		25/3-24 (4x3055351R91) 32 mm	25/28-14 (3132018R2)	25/26-24 (3055033R1 + 3055034R1)	25/11-18 (A) (3228401R91)	25/13-16 (3138701R91)	D239	574, 674, 684, 685, 695, 724, 743, 744, 745, 833, 840, 940, 4210
25/1-70 (3228376R91)	25/2-24 (1x3055129R21 4x3055130R21)	25/3-25 (4x3144688R92) 30 mm					D246	278, 784, 785, 795, 824, 844, 4220
		25/3-34 (4x3132101R91) 32 mm					D268	844S, 845, 884, 885, 895, 4230
							DT239	856
							DT268	995, 4240
Motoren 6 Zyl.								
		25/3-26 (6x3055351R91)	25/28-14 (3132018R2)				D310	946, 955
25/1-45 (3136036R95, 3059514R1)	25/2-26 (1x3055129R21 6x3055130R21)	25/3-46 (6x3132101R91) 32 mm		25/26-24 (3055033R1 + 3055034R1)	25/11-18 (A) (3228401R91)	25/13-16 (3138701R91)	D358	956, 1046, 1055, 1056
		25/3-47 (6x3218422R91) 30 mm	25/28-46 (3218317R1)				DT358	1246, 1255
							DT402	1455

Wir vertreiben keine Originalteile.
Die Nummern dienen lediglich als Beschreibung.

"THE RELIABLE SERVICE"

KURBELWELLEN & EINZELTEILE

Motoren IH

Bestell-Nr.	Beschreibung	Schleppertyp	OEM	Abb.
25/11-19	Kurbelwellendichtungssatz vorne	D155, D206, D310, D179, D239, D246, D268, DT358, DT402	3228133R93	
25/17-11	Kurbelwellengehäusedichtung		3055215R3	
25/17-118	Gummikeil		714868R1	

HAUPT- & PLEUELLAGERSÄTZE

Vergleichsliste für Untermaß Hauptlager				Vergleichsliste für Untermaß Pleuellager			
Standard	0.25mm	0.50mm	0.75mm	Standard	0.25mm	0.50mm	0.75mm
25/2-21	25/2-21 A (B221A)	25/2-21 B (B221B)	25/2-21 C (708913R91)	25/3-21	25/3-21 A (4x3070539R91)	25/3-21 B (B321B)	25/3-21 C (4x3070537R11)
25/2-23	25/2-23 A (1x3056820R11 3x3056832R21)	25/2-23 B (1x3056875R11 3x3056877R21)	25/2-23 C (1x3055776R11 3x3055779R21)	25/3-23	25/3-23 A (3x3056834R11)	25/3-23 B (3x3056879R11)	25/3-23 C (3x3055781R11)
25/2-24	25/2-24 A (1x3056820R11 4x3056832R21)	25/2-24 B (1x3056875R11 4x3056877R21)	25/2-24 C (1x3055776R11 4x3055779R21)	25/3-24	25/3-24 A (4x3056834R11)	25/3-24 B (4x3056879R11)	25/3-24 C (4x3055781R11)
25/2-26	25/2-26 A (1x3056820R11 6x3056832R21)	25/2-26 B (1x3056875R11 6x3056877R21)	25/2-26 C (1x3055776R11 6x3055779R21)	25/3-25	25/3-25 A (4x3144876R92)	25/3-25 B (4x3144881R92)	25/3-25 C (4x3144886R92)
				25/3-26	25/3-26 A (6x3056834R11)	25/3-26 B (6x3056879R11)	25/3-26 C (6x3055781R11)
				25/3-34	25/3-34 A (4x3136203R11)	25/3-34 B (4x3136329R11)	
				25/3-46	25/3-46 A (6x3136203R11)	25/3-46 B (6x3136329R11)	
				25/3-47	25/3-47 A (6x3228663R91)	25/3-47 B (6x3228667R91)	

Wir vertreiben keine Originalteile.
Die Nummern dienen lediglich als Beschreibung.



"THE RELIABLE SERVICE"



STARTERKRÄNZE & SCHWUNGRÄDER

Motoren IH

1

2

Bestell-Nr.	Abb.	Beschreibung	Schleppertyp	OEM
25/15-28	1	126Z Ø 371 - 405 mm	238, 248, 258, 268, 278, 385, 395, 454, 474, 484, 485, 485XL, 495, 495XL, 574, 584, 585, 585XL, 595, 595XL, 674, 684, 685, 685XL, 695, 695XL, 784, 785, 785XL, 795, 795XL, 885, 2400, 2500, 3210, 3220, 3230, 4210, 4220	60883H
25/296-12	2	127Z 11"	258, 268, 278, 474, 574, 584, 585, 595, 674, 684, 685, 784, 785, 3230	3136044R41, 3136044R11
25/296-13	2	127Z 12"	258, 268, 585, 595, 685, 695, 785, 795, 3230, 4210, 4220	1808412C91
25/15-27	1	128Z Ø 372 - 412 mm	288, 685, 785, 884, 885, 885XL, 895, 895XL, 995, 995XL, 4230, 4240	3218637R1
25/296-14	2	128Z 12"		1808413C91, 1808413C92
25/15-34	1	Ø 363 / 325 mm	353, 383, 423, 433, 440, 453, 533, 540	3055358R1
25/15-23	1	129Z Ø 357 - 393 mm T. : 18mm	454, 553, 644, 654, 724, 743, 743XL, 744, 745S, 745XL, 824, 845, 946, 1046, 1246, 2400	3055133R1
25/296-6	2	134Z	745S, 844, 844S, 844XL, 845, 845XL	3144651R92
25/15-9	1	134Z Ø 357 mm T. : 25mm		3144607R1
25/296-15	2	134Z	856XL, 955, 955XL, 956, 956XL, 1055, 1055XL, 1056, 1056XL	3218474R92
25/15-9	1	134Z Ø 357 mm T. : 25mm	1255, 1255XL, 1455, 1455XL	3144607R1

RIEMENSCHLEIBE

Bestell-Nr.	Schleppertyp	OEM	Abb.
25/59-8	644, 654, 724, 733, 740, 743, 743XL, 744, 745S, 745XL, 824, 833, 840, 844, 844S, 844XL, 845, 845XL, 940	3138834R1	

Wir vertreiben keine Originalteile.
 Die Nummern dienen lediglich als Beschreibung.



"THE RELIABLE SERVICE"

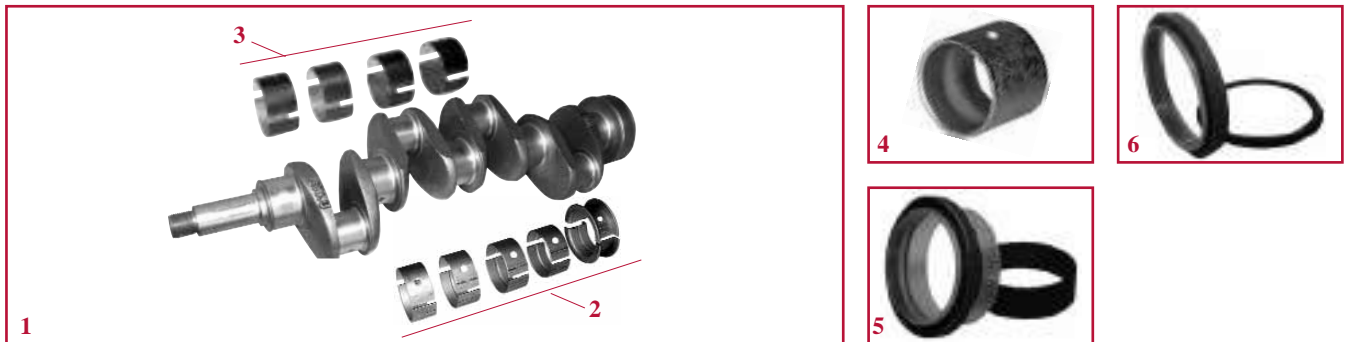

KURBELWELLEN & EINZELTEILE
Motoren Cummins

1	2	3	4	5	6	Motor	Schleppertyp
Kurbelwelle	Hauptlager	Pleuellager	Pleuelbuchsen	Wellendichtring vorne	Wellendichtring hinten		
Motoren 4 Zyl.							
	25/2-13 (1 x A77406 4 x A77405)	25/3-13 (4 x A77465)	25/28-49 (J901085, J941476, 87403209)	25/11-49 (A77890) (Satz)	25/13-49 (J909411, J909090) (Satz)	4T390	5120, 5220
Motoren 6 Zyl.							
25/1-49 (J908032, J918324)	25/2-49 (1 x A77406 6 x A77405)	25/3-49 (6 x A77465)	25/28-49 (J901085, J941476, 87403209)	25/11-49 (A77890) (Satz)	25/13-49 (J909411, J909090) (Satz)	6-590	5130, 5230
						6T590	5140, 5150, 5240, 5250 MX100, MX110, MX120, MX135 MX150, MX170
	25/2-66 (1 x A77706 6 x A77711)	25/3-66 (6 x A77563)	25/28-66 (J913900, J913990)	25/11-66 (A77790) (Satz)	25/13-66 (A77809, J904410, J353978, J934486) (Satz)	6T830	7110, 7120, 7130, 7140, 7150, 7210, 7220, 7230, 7240, 7250, 8910, 8920, 8930, 8940, 8950, 9110, 9130, 9210, 9230, 9240, 9310, 9330 MX180, MX200, MX210, MX220, MX230, MX240, MX255, MX270, MX285
						6T8304	STX275, STX325

Bestell-Nr.	Beschreibung	Schleppertyp	OEM	Abb.
25/17-119	Kurbelwellengehäusedichtung	5120, 5130, 5140, 5150, 5220, 5230, 5240, 5250, MX100, MX110, MX120, MX135, MX150, MX170 Mähdrescher 1644, 2044, 2144, 2344	J928493, J938159	

Wir vertreiben keine Originalteile.
Die Nummern dienen lediglich als Beschreibung.

"THE RELIABLE SERVICE"

KURBELWELLEN & EINZELTEILE

Motoren Cummins

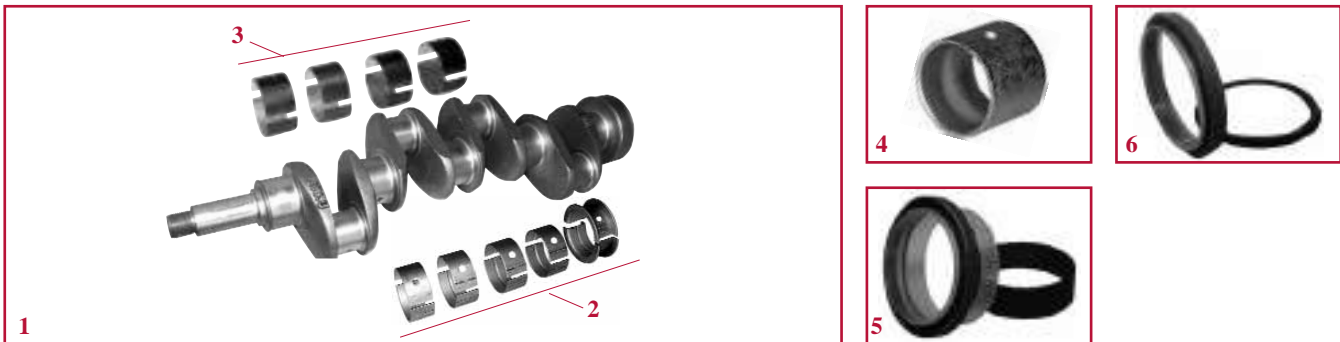

1	2	3	4	5	6		
Kurbelwelle	Hauptlager	Pleuellager	Pleuelbuchsen	Wellendichtring vorne	Wellendichtring hinten	Motor	Schleppertyp
Mähdrescher							
25/1-49 (J908032, J918324)	25/2-49 (1 x A77406 6 x A77405)	25/3-49 (6 x A77465)	25/28-49 (J901085, J941476, 87403209)	25/11-49 (A77890, J906080) (Satz)	25/13-49 (J909411, J909090) (Satz)	6T590	1620, 1640
							1644, 2144, 2344
	25/2-66 (1 x A77706, J945929, 6 x A77711, J945930)	25/3-66 (6 x A77563)	25/28-66 (J913900, J913990)	25/11-66 (A77790) (Satz)	25/13-66 (A77809, J904410, J353978, J934486) (Satz)	6T830	1660, 1666, 1670, 1680, 1688, 2166, 2188, 2365, 2366, 2388, CF60

HAUPT- & PLEUELLAGERSÄTZE

Vergleichsliste für Untermaß Hauptlager				Vergleichsliste für Untermaß Pleuellager			
Standard	0.25mm	0.50mm	0.75mm	Standard	0.25mm	0.50mm	0.75mm
25/2-13	25/2-13 A (1 x A77473 4 x A77472)	25/2-13 B (1 x A77475 4 x A77474)	25/2-13 C (1 x A77477 4 x A77476)	25/3-13	25/3-13 A (4 x A77466)	25/3-13 B (4 x A77467)	25/3-13 C (4 x A77468)
25/2-49	25/2-49 A (1 x A77473 6 x A77472)	25/2-49 B (1 x A77475 6 x A77474)	25/2-49 C (1 x A77477 6 x A77476)	25/3-49	25/3-49 A (6 x A77466)	25/3-49 B (6 x A77467)	25/3-49 C (6 x A77468)
25/2-66	25/2-66 A (1 x A77707 6 x A77712)	25/2-66 B (1 x A77708 6 x A77713)	25/2-66 C (1 x A77709 6 x A77714)	25/3-66	25/3-66 A (6 x A77564)	25/3-66 B (6 x A77565)	25/3-66 C (6 x A77566)

Wir vertreiben keine Originalteile.
Die Nummern dienen lediglich als Beschreibung.



"THE RELIABLE SERVICE"



KURBELWELLEN & EINZELTEILE

Motoren MWM

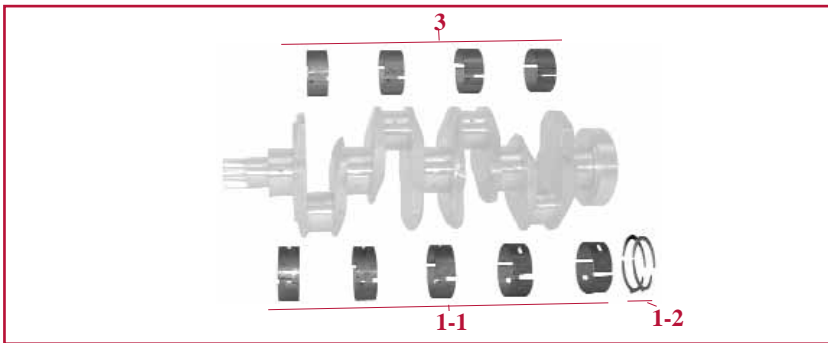

1	3	4	5	6	7		
Hauptlager	Pleuellager	Pleuelbuchsen	Pleuelschrauben	Wellendichtring vorne	Wellendichtring hinten	Motor	Schleppertyp
Motoren 3 Zyl.							
25/2-100 (1-1) (4x130100010755)	25/3-100 (3x130100030714) Ø 63 mm	25/28-100 (130100030705) Ø 35 mm	25/26-100 (130100030707)	25/11-100 (130100010727) 78x100x13 mm	25/13-100 (130100010728) 110x130x13 mm	D 226-B 3	C55, C55A
25/6-100 (1-2) (2x130100010754) Ø 70 mm						TD 226-B 3	C64, C64A, C70A, CS68, CS75 (⇒ 12/98)
Motoren 4 Zyl.							
25/2-101 (5x130100010755)	25/3-101 (4x130100030714) Ø 63 mm	25/28-100 (130100030705) Ø 35 mm	25/26-100 (130100030707)	25/11-100 (130100010727) 78x100x13 mm	25/13-100 (130100010728) 110x130x13 mm	TD 226-B 4	CS78, CS86, CS94 (⇒ 12/98)
25/6-100 (1-2) (2x130100010754) Ø 70 mm							

HAUPT- & PLEUELLAGERSÄTZE

Vergleichsliste für Untermaß Hauptlager				Vergleichsliste für Untermaß Pleuellager			
Standard	0.25mm	0.50mm	0.75mm	Standard	0.25mm	0.50mm	0.75mm
25/2-100	25/2-100 A	25/2-100 B	25/2-100 C	25/3-100	25/3-100 A	25/3-100 B	25/3-100 C
25/2-101	25/2-101 A	25/2-101 B	25/2-101 C	25/3-101	25/3-101 A	25/3-101 B	25/3-101 C

Bestell-Nr.	Beschreibung	Schleppertyp	OEM	Abb.
25/17-129	Kurbelwellengehäusedichtung	C55, C64, C70A, CS68, CS75, CS78, CS86, CS94	130100010726, 130100010757	

Wir vertreiben keine Originalteile.
Die Nummern dienen lediglich als Beschreibung.



"THE RELIABLE SERVICE"



KURBELWELLEN & EINZELTEILE

Motoren Sisu

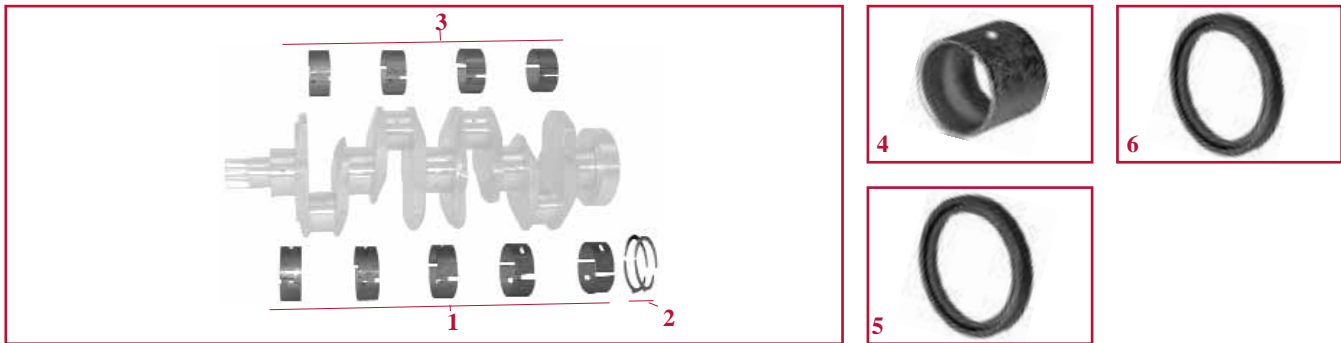

1	2	3	4	5	6	Motor	Schleppertyp
Hauptlager	Anlaufscheiben	Pleuellager	Pleuelbuchsen	Wellendichtring vorne	Wellendichtring hinten		
Motoren 3 Zyl.							
25/2-97 (4 x) 162000010781, 836119457) Ø 85 mm	25/6-97 (2 x) 162000010714)	25/3-97 (3 x) 162000030702, 836110552) Ø 68 mm	25/28-97 (162000030705, 836646271)	25/11-97 (162000010700, 614105880)	25/13-97 (299939A1, 162000010703)	320D	CS68, CS75 (1/99 ⇒)
Motoren 4 Zyl.							
25/2-98 (5 x) 162000010781, 836119457) Ø 85 mm	25/6-97 (2 x) 162000010714)	25/3-98 (4 x) 162000030702, 836110552) Ø 68 mm	25/28-97 (162000030705, 836646271)	25/11-97 (162000010700, 614105880)	25/13-97 (299939A1, 162000010703)	420D	CS78, CS86, CS94 (1/99 ⇒) CS100, CS110
Motoren 6 Zyl.							
25/2-99 (7 x) 162000010781, 836119457) Ø 85 mm	25/6-97 (2 x) 162000010714)	25/3-99 (6 x) 162000030702, 836110552) Ø 68 mm	25/28-97 (162000030705, 836646271)	25/11-97 (162000010700, 614105880)	25/13-97 (299939A1, 162000010703)	620D	CS120, CS130, CS150, CVX120, CVX130, CVX150, CVX170, CVX1135, CVX1145, CVX1155, CVX1170, CVX1190

HAUPT- & PLEUELLAGERSÄTZE

OEM Nummern für Untermaß Hauptlager				OEM Nummern für Untermaß Pleuellager			
Standard	0.25mm	0.50mm	0.75mm	Standard	0.25mm	0.50mm	0.75mm
25/2-97	25/2-97 A	25/2-97 B	25/2-97 C	25/3-97	25/3-97 A	25/3-97 B	25/3-97 C
25/2-98	25/2-98 A	25/2-98 B	25/2-98 C	25/3-98	25/3-98 A	25/3-98 B	25/3-98 C
25/2-99	25/2-99 A	25/2-99 B	25/2-99 C	25/3-99	25/3-99 A	25/3-99 B	25/3-99 C

Wir vertreiben keine Originalteile.
Die Nummern dienen lediglich als Beschreibung.



"THE RELIABLE SERVICE"



KURBELWELLEN & EINZELTEILE

Motoren Perkins

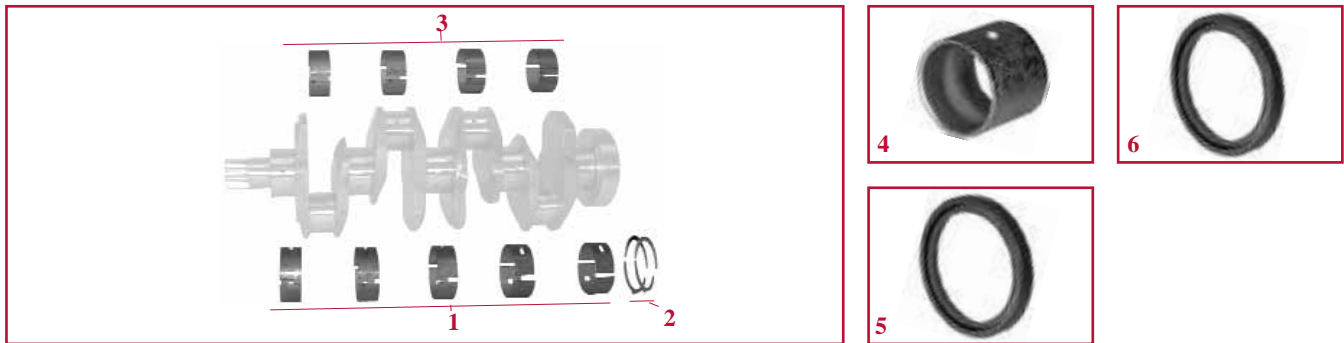

1	2	3	4	5	6	Motor	Schleppertyp
Hauptlager	Anlaufscheiben	Pleuellager	Pleuelbuchsen	Wellendichtring vorne	Wellendichtring hinten		
Motoren 3 Zyl.							
25/2-86 (304892A1, 130300010720, 130300010757)	25/6-86 (2 x 296150A1, 130300010724)	25/3-86 (296245A1, 130300030701)	25/28-86 (296149A1, 130300030707)	25/11-86 (295810A1, 130300010741)	25/13-86 (218271A1, 3235723A1)	903.27	C50, CS48, CS52, CX50
	+ 2 x 296151A1, 130300010726)	25/3-87 (296260A1, 130300030713)				903.27T	C60, CS58, CS63, CX60
Motoren 4 Zyl.							
25/2-22 (3118150R1)	25/6-16 (2 x 796189R1 + 2 x 796190R1)	25/3-22 (3118135R1)	25/28-13 (795775R1)	25/11-17 (3118128R91)	25/13-15 (795662R1)	A4.212	475
25/2-88 (3118150R1, 218284A1)	25/6-88 (2 x 218292A1 + 2 x 218294A1)	25/3-88 (218627A1)	25/28-88 (293493A1)	25/11-88 (218375A1, 2415361)	25/13-86 (218271A1, 3235723A1)	1004.4T	C70, C80, C90, CX70, CX80, CX90, CX100, MX80C, MX90C, MX100C

HAUPT- & PLEUELLAGERSÄTZE

Vergleichsliste für Untermaß Hauptlager				Vergleichsliste für Untermaß Pleuellager			
Standard	0.25mm	0.50mm	0.75mm	Standard	0.25mm	0.50mm	0.75mm
25/2-22	25/2-22 A	25/2-22 B	25/2-22 C	25/3-22	25/3-22 A	25/3-22 B	25/3-22 C
25/2-86	25/2-86 A	25/2-86 B	25/2-86 C	25/3-86	25/3-86 A	25/3-86 B	25/3-86 C
25/2-88	25/2-88 A	25/2-88 B	25/2-88 C	25/3-87	25/3-87 A	25/3-87 B	25/3-87 C
				25/3-88	25/3-88 A	25/3-88 B	25/3-88 C

Wir vertreiben keine Originalteile.
 Die Nummern dienen lediglich als Beschreibung.



"THE RELIABLE SERVICE"



STARTERKRANZ

Motoren Perkins

Bestell-Nr.	Beschreibung	Schleppertyp	OEM	Abb.
25/15-31	115 z Ø 340 mm	475, C50, C60, C70, C80, C90, CS48, CS52, CS58, CS63, CX50, CX60, CX70, CX80, CX90	3118310R1, 130300020708	
25/15-32	126 z Ø 376 mm	MX80C, MX90C, MX100C	218497A1	

KURBELWELLENGEHÄUSEDICHTUNG

Bestell-Nr.	Beschreibung	Schleppertyp	OEM	Abb.
25/17-136	Kurbelwellengehäusedichtung	C50, C50, CS48, CS52, CS58, CS63, CX50, CX60	296202A1, 130300010703	

Wir vertreiben keine Originalteile.
Die Nummern dienen lediglich als Beschreibung.



"THE RELIABLE SERVICE"



KURBELWELLEN & EINZELTEILE

Motoren Iveco

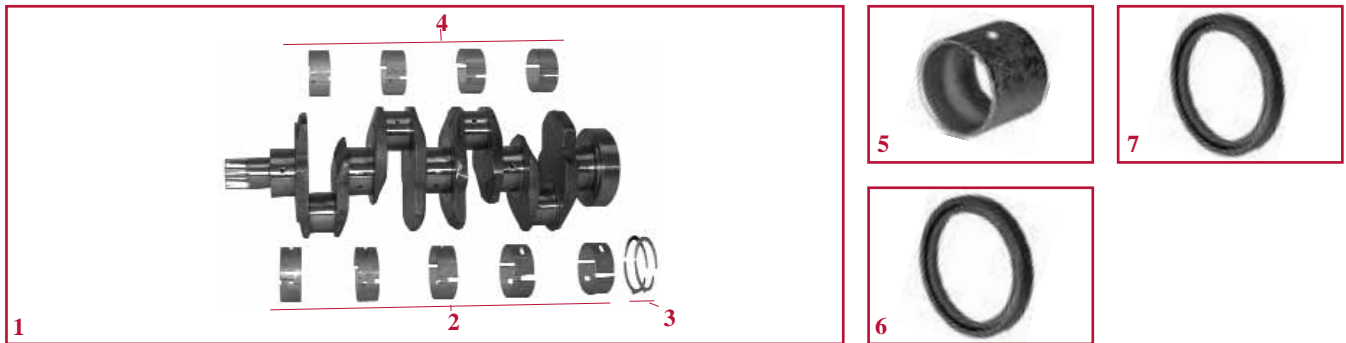

1	2	3	4	5	6	7	Motor	Schleppertyp
Kurbelwellensatz	Hauptlager	Anlaufscheiben	Pleuellager	Pleuelbuchsen	Wellendichtring vorne	Wellendichtring hinten		
Motoren 3 Zyl.								
	25/2-67 (4 x 1930812)	25/6-67 (1901385)	25/3-67 (3 x 1930181) mit Bohrung 25/3-68 (3 x 1930201) ohne Bohrung	25/28-67 (4766404, 98460411, 99432366) Ø 38 mm	25/11-67 (98461684) 42 x 65 x 12	25/13-67 (98461686, 99457401) 114 x 135 x 13	8035.05	AVJ60, JX60, JX65, JX70, JX1060C, JX1070C, JX1075C, VJ60
							8035.06	AVJ55, JX55
Motoren 4 Zyl.								
25/1-84 (98451529, 4785110)	25/2-84 (5 x 1930812)	25/6-67 (1901385)	25/3-84 (4 x 1930181) mit Bohrung 25/3-85 (4 x 1930201) ohne Bohrung	25/28-67 (4766404, 98460411, 99432366) Ø 38 mm	25/11-67 (98461684) 42 x 65 x 12	25/13-67 (98461686, 99457401) 114 x 135 x 13	8045.05	JX80, JX80U, JX85, JX90, JX90U, JX95, JX100U, VJ80
							8045.06	AVJ70, JX70U, JX75, VJ70

HAUPT- & PLEUELLAGERSÄTZE

Vergleichsliste für Untermaß Hauptlager				Vergleichsliste für Untermaß Pleuellager			
Standard	0.25mm	0.50mm	0.75mm	Standard	0.25mm	0.50mm	0.75mm
25/2-22	25/2-22 A	25/2-22 B	25/2-22 C	25/3-22	25/3-22 A	25/3-22 B	25/3-22 C
25/2-86	25/2-86 A	25/2-86 B	25/2-86 C	25/3-86	25/3-86 A	25/3-86 B	25/3-86 C
25/2-88	25/2-88 A	25/2-88 B	25/2-88 C	25/3-87	25/3-87 A	25/3-87 B	25/3-87 C
				25/3-88	25/3-88 A	25/3-88 B	25/3-88 C

STARTERKRANZ

Bestell-Nr.	Beschreibung	Schleppertyp	OEM	Abb.
25/15-29	110Z Ø 293 mm	JX55, JX60, JX65, JX70, JX70U, JX75, JX80, JX80U, JX85, JX90, JX90U, JX95, JX100U, JX1060C, JX1060V, JX1070C, JX1070N, JX1070V, JX1075C, JX1075N, JX1075V	4602143	

Wir vertreiben keine Originalteile.
Die Nummern dienen lediglich als Beschreibung.



"THE RELIABLE SERVICE"



KURBELWELLEN & EINZELTEILE

Motoren Ford



1	2	3	4	5	Motor	Schleppertyp
Hauptlager	Wellendichtring vorne	Wellendichtring hinten	Zahnrad	Gehäusedichtung		
Motoren 6 Zyl						
25/2-105 (6 x 87790260 + 1 x 87790266)	25/11-105 (87802755, 87800696)	25/13-105 (83955247, 87802757)	25/12-19 (83993159)	25/17-16 (87801610)	675/TA	MXM120, MXM130, MXM135, MXM140, MXM150, MXM155, MXM165, MXM175, MXM180, MXM190

PLEUELSTANGE & EINZELTEILE



1	2	3	4	Motor	Schleppertyp
Pleuelstange	Pleuellager	Pleuelbuchsen	Pleuelschrauben		
Motoren 6 Zyl.					
25/25-28 (87801219)	25/3-105 (6 x 87790304)	25/28-51 (87840994)	25/26-27 (87802307, 83991682)	675/TA	MXM120, MXM130, MXM135, MXM140, MXM150, MXM155, MXM165, MXM175, MXM180, MXM190

STARTERKRANZ

Bestell-Nr.	Beschreibung	Schleppertyp	OEM	Abb.
25/15-30	128Z Ø 372 mm	MXM120, MXM130, MXM135, MXM140, MXM150, MXM155, MXM165, MXM175, MXM180, MXM190	83949153	

Wir vertreiben keine Originalteile.
Die Nummern dienen lediglich als Beschreibung.



"THE RELIABLE SERVICE"



KURBELWELLEN & EINZELTEILE

Motoren Same

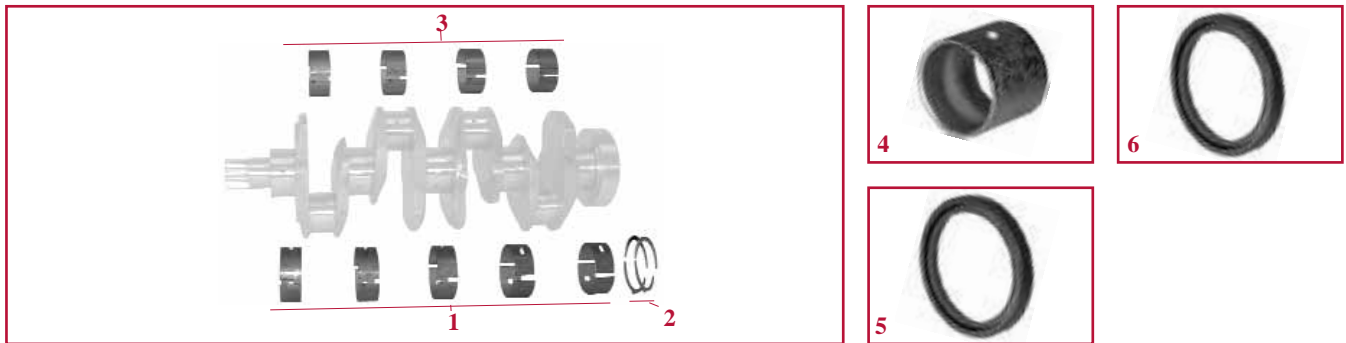

1	2	3	4	5	6	Motor	Schleppertyp
Hauptlager	Anlaufscheiben	Pleuellager	Pleuelbuchsen	Wellendichtring vorne	Wellendichtring hinten		
Motoren 3 Zyl.							
25/2-106 (4 x 1966294C1 + 4 x 1966297C1)	25/6-106 (4 x 1966647C1)	25/3-106 (6 x 1966300C1)	25/28-106 (1966466C1)	25/11-106 (137845A1, 1966692C1)	25/13-106 (1966693C1)	1000.3A	2120, 2130, PJ55, PJN55, PJV55
Motoren 4 Zyl.							
25/2-107 (5 x 1966294C1 + 5 x 1966297C1)	25/6-106 (4 x 1966647C1)	25/3-107 (8 x 1966300C1)	25/28-106 (1966466C1)	25/11-106 (137845A1, 1966692C1)	25/13-106 (1966693C1)	1000.4A	2140, 2150, PJ65, PJ75, PJN65, PJN75, PJV65, PJV75

HAUPT- & PLEUELLAGERSÄTZE

Vergleichsliste für Untermaß Hauptlager				Vergleichsliste für Untermaß Pleuellager			
Standard	0.25mm	0.50mm	0.75mm	Standard	0.25mm	0.50mm	0.75mm
25/2-106	25/2-106 A	25/2-106 B	25/2-106 C	25/3-106	25/3-106 A	25/3-106 B	25/3-106 C
25/2-107	25/2-107 A	25/2-107 B	25/2-107 C	25/3-107	25/3-107 A	25/3-107 B	25/3-107 C

Wir vertreiben keine Originalteile.
Die Nummern dienen lediglich als Beschreibung.



"THE RELIABLE SERVICE"



KOLBEN, BUCHSEN & RINGE
Motoren IH - Alte Serie



1	2	3	Bohrung	Typ	Schleppertyp
KBR-Sätze	Satz Kolbenringe	Dichtung			
Motoren 2 Zyl.					
25/31-115 (A) (3054295R91)	25/34-112 (3050150R92)	25/38-114 (711048R2)	82.5 mm	D66	D212, D214, D215, DLD2
25/31-111 (A) (714852R98)	25/34-111 (3050149R92)	25/38-113 (714854R1)	87.3 mm	D74	D217, D219
Motoren 3 Zyl.					
25/31-115 (A) (3054295R91)	25/34-112 (3050150R92)	25/38-114 (711048R2)	82.5 mm	D99	D320, D322, DED3
25/31-111 (A) (714852R98)	25/34-111 (3050149R92)	25/38-113 (714854R1)	87.3 mm	D111	D324, D326, 323
Motoren 4 Zyl.					
25/31-115 (A) (3054295R91)	25/34-112 (3050150R92)	25/38-114 (711048R2)	82.5 mm	D132	D430, D432, D440, DGD4
25/31-112 (A) (718201R96)	25/34-111 (3050149R92)	25/38-112 (718203R1)	87.3 mm	D148	D436, D438, D439

(A) Incl. Zylinderbuchsenabdichtungen

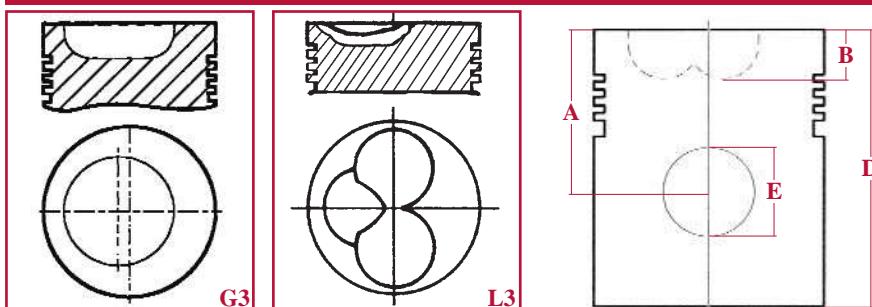

KOLBEN

Motoren IH - Alte Serie



- A** : Kompressionshöhe (mm)
- B** : Brennkerntiefe (mm)
- D** : Gesamthöhe (mm)
- E** : Kolbenbolzendurchmesser (mm)
- Al-fin** : Ringträgerkolben

Bestell-Nr.	Motoren	Bohrung Ø	Typ	Ringe	Al-fin	A mm	B mm	D mm	E mm
25/31-111	D74	87.3	G3	5	Nein	50.9	5.5	99	28
25/31-112	D148	87.3		5	Nein	50.9	5.5	99	28
25/31-115	D66	82.5	G3	5	Nein	50.9	5.5	99	28

BUCHSE

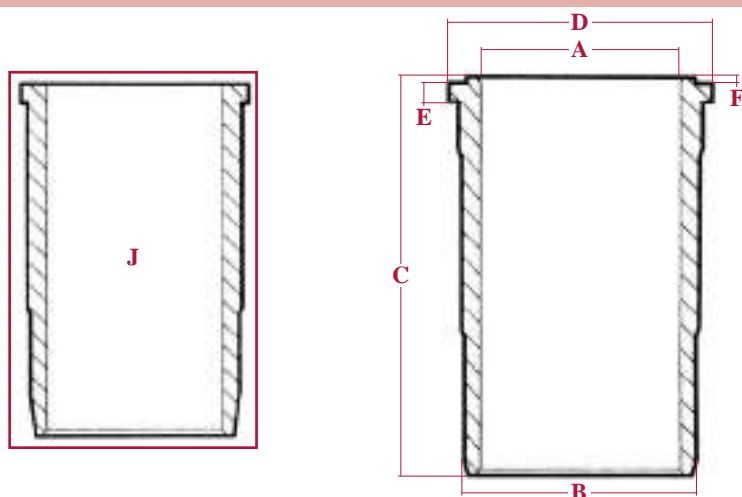

- A** : Bohrung (mm)
- B** : Durchmesser Aussen (mm)
- C** : Gesamthöhe (mm)
- D** : Durchmesser Kragen (mm)
- E** : Kragenhöhe (mm)
- F** : Feuersteghöhe (mm)

Bestell-Nr.	Typ	A mm	B mm	C mm	D mm	E mm	F mm
25/31-111	J	87.3	95.25	179.4	104	5.77	-
25/31-115	J	82.5	90.4	179.5	99.3	5.79	-

KOLBENRINGE

Bestell-Nr.	Motoren	Bohrung Ø						
25/34-111	D74	87.3						
			P1 2.38	P1 2.38	P1 2.38	SS 4.75	SS 4.75	
25/34-112	D66	82.5						
			P1 2.38	T1 2.38	T1 2.38	BE 4.75	SS 4.75	

- BE** : Abstreifring mit Spannfeder
- P1** : Rechteckring
- SS** : Doppelabstreifring
- T1** : Kompressionsring (konisch)

Wir vertreiben keine Originalteile.
Die Nummern dienen lediglich als Beschreibung.



"THE RELIABLE SERVICE"



KOLBEN, BUCHSEN & RINGE
Motoren IH

1	2	3	4	5	Bohrung	Typ	Schleppertyp
Satz (A)	Kolben	Satz Kolbenringe	Buchse	Buchsendichtung			
Motoren 3 Zyl.							
25/31-62 (3218758R95) 25/31-64 (3139586R95) AL-FIN	25/33-62 25/33-64 AL-FIN	25/34-62 (3218416R92) 25/34-65 (3139594R91) AL-FIN 25/34-60 (3059262R92) AL-FIN 4 Kolbr.	25/35-62 (3139587R3)	25/38-62 (3228344R1) Ø 5 mm 25/38-63 (3228348R1) Ø 4.7 mm	98.4 mm	D155 (B)	353, 383, 385, 395, 423, 433, 440, 453, 533, 540, 3210
25/31-63 (3218759R95) 25/31-65 (3139591R96) AL-FIN 25/31-185 (D) (1806470C91) AL-FIN	25/33-63 25/33-65 AL-FIN 25/33-185 AL-FIN	25/34-62 (3218416R92) 25/34-65 (3139594R91) AL-FIN 25/34-60 (3059262R92) AL-FIN 4 Kolbr. 25/34-65 (3139594R91) AL-FIN	25/35-63 (3139592R4)		98.4 mm	D179 (C)	248, 454, 464, 484, 485, 495, 523, 553, 633, 640, 2400, 3220
Motoren 4 Zyl.							
25/31-42 (751604R92)	25/33-42 (704099R2, 3048523R1)	25/34-42 (751607R91, 3114775R91)	25/35-42 (704092R1)	25/38-42 (704100R1)	85.7 mm	BD144	B275, 276, 354
25/31-44 (3044479R94)	25/33-44 (3044486R3)	25/34-44 (3114778R91)	25/35-44 (3044481R3)		88.9 mm	BD154	238, 374, 384, B414, 424, 434, 444
25/31-62 (3218758R95) 25/31-64 (3139586R95) AL-FIN	25/33-62 25/33-64 AL-FIN	25/34-62 (3218416R92) 25/34-65 (3139594R91) AL-FIN 25/34-60 (3059262R92) AL-FIN 4 Kolbr.	25/35-62 (3139587R3)	25/38-62 (3228344R1) Ø 5 mm 25/38-63 (3228348R1) Ø 4.7 mm	98.4 mm	D206 (B)	474, 584, 585, 595, 624, 644, 645, 654, 733, 740, 3230

(A) Incl. Zylinderbuchsenabdichtungen

(B) Hub: 111.1 mm

(C) Hub: 128.5 mm

(D) Hochkompressionskolben

Wir vertreiben keine Originalteile.

Die Nummern dienen lediglich als Beschreibung.

"THE RELIABLE SERVICE"

KOLBEN, BUCHSEN & RINGE
Motoren IH

1	2	3	4	5	Bohrung	Typ	Schleppertyp
KBR-Sätze (A)	Kolben	Satz Kolbenringe	Buchse	Buchsendichtung			
Motoren 4 Zyl.							
25/31-63 (3218759R95) 25/31-65 (3139591R96) AL-FIN 25/31-185 (D) (1806470C91) AL-FIN	25/33-63 25/33-65 AL-FIN 25/33-185 AL-FIN	25/34-62 (3218416R92) 25/34-65 (3139594R91) AL-FIN 25/34-60 (3059262R92) AL-FIN 4 Kolbr. 25/34-65 (3139594R91) AL-FIN	25/35-63 (3139592R4) 25/35-66 (3144682R3)	25/38-62 (3228344R1) Ø 5 mm 25/38-63 (3228348R1) Ø 4.7 mm	98.4 mm 100 mm 100 mm 98.4 mm 100 mm	D239 (C) D246 D268 DT239 (C) DT268	574, 674, 684, 685, 695, 724, 743, 744, 745, 833, 840, 940, 4210 278, 784, 785, 795, 824, 844, 4220 844S, 845, 884, 885, 895, 4230 856 995, 4240

- (A) Incl. Zylinderbuchsenabdichtungen
- (B) Hub: 111.1 mm
- (C) Hub: 128.5 mm
- (D) Hochkompressionskolben

Peuelstange zum Motor BD154

Bestell-Nr.	Beschreibung	Schleppertyp	OEM	Abb.
25/25-42	88,9mm Bohrung	238, 374, 384, B414, 424, 434, 444	3061214R91	

Wir vertreiben keine Originalteile.
 Die Nummern dienen lediglich als Beschreibung.

"THE RELIABLE SERVICE"

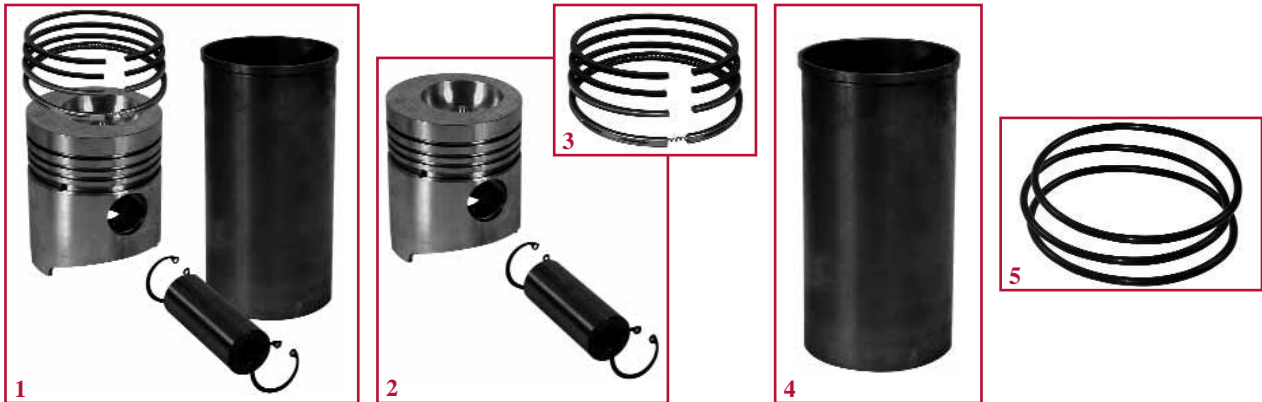
KOLBEN, BUCHSEN & RINGE
Motoren IH

1	2	3	4	5				
KBR-Sätze (A)	Kolben	Satz Kolbenringe	Buchse	Buchsendichtung	Bohrung	Typ	Schleppertyp	
Motoren 6 Zyl.								
25/31-62 (3218758R95) 25/31-64 (3139586R95) AL-FIN	25/33-62 25/33-64 AL-FIN	25/34-62 (3218416R92) 25/34-65 (3139594R91) AL-FIN 25/34-60 (3059262R92) AL-FIN 4 Kolbr.	25/35-62 (3139587R3)		98.4 mm	D310 (B)	946, 955	
25/31-63 (3218759R95) 25/31-65 (3139591R96) AL-FIN	25/33-63 25/33-65 AL-FIN	25/34-62 (3218416R92) 25/34-65 (3139594R91) AL-FIN 25/34-60 (3059262R92) AL-FIN 4 Kolbr.	25/35-63 (3139592R4)		25/38-62 (3228344R1) Ø 5 mm 25/38-63 (3228348R1) Ø 4.7 mm	98.4 mm	D358 (C)	956, 1046, 1055, 1056
25/31-185 (D) (1806470C91) AL-FIN	25/33-185 AL-FIN	25/34-65 (3139594R91) AL-FIN						
25/31-113 (3144516R97) AL-FIN	25/32-113 Mit Kolbr.	25/34-65 (3139594R91) AL-FIN				98.4 mm	DT358 (C)	1246, 1255
25/31-114 (3218915R95)	25/32-114 Mit Kolbr.	25/34-114 (3218920R91) AL-FIN	25/35-66 (3144682R3)			100 mm	DT402	1455

- (A) Incl. Zylinderbuchsenabdichtungen
- (B) Hub: 111.1 mm
- (C) Hub: 128.5 mm
- (D) Hochkompressionskolben

Wir vertreiben keine Originalteile.
 Die Nummern dienen lediglich als Beschreibung.

"THE RELIABLE SERVICE"

KOLBEN

Motoren IH

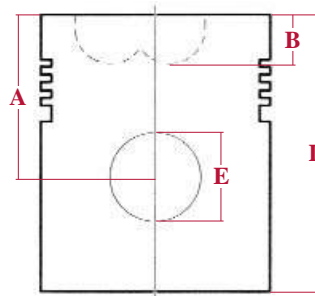
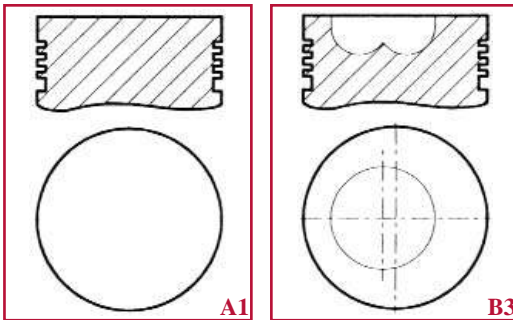

- A** : Kompressionshöhe (mm)
- B** : Brennkerntiefe (mm)
- D** : Gesamthöhe (mm)
- E** : Kolbenbolzendurchmesser (mm)
- Al-fin** : Ringträgerkolben

Bestell-Nr.	Motoren	Bohrung Ø	Typ	Ringe	Al-fin	A mm	B mm	D mm	E mm
25/33-42	BD144	85.72	A1	5	Nein	50.95	-	98.98	28.00
25/33-44	BD154	88.90	A1	5	Nein	50.90	-	99.00	28.00
25/33-62	D155, D206, D310	98.42	B3	3	Nein	67.00	19.90	101.50	36.00
25/33-63	D179, D239, D358	98.42	B3	3	Nein	67.00	24.00	101.50	36.00
25/33-64	D155, D206, D310	98.42	B3	3	Ja	67.00	19.90	107.00	36.00
25/33-65	D179, D239	98.42	B3	3	Ja	67.00	24.00	107.00	36.00
25/33-66	D246	100.00	B3	3	Nein	67.00	22.30	107.00	36.00
25/33-67	D268	100.00	B3	3	Ja	67.00	24.00	107.00	36.00
25/32-113	DT239, DT358	98.42	B3	3	Ja	67.00	23.80	107.00	38.00
25/32-114	DT268, DT402	100.00	B3	3	Ja	64.80	24.00	107.00	38.00
25/33-185	D179, D239, D358	98.42	B3	3	Ja	67.00	22.10	107.00	36.00

BUCHSE

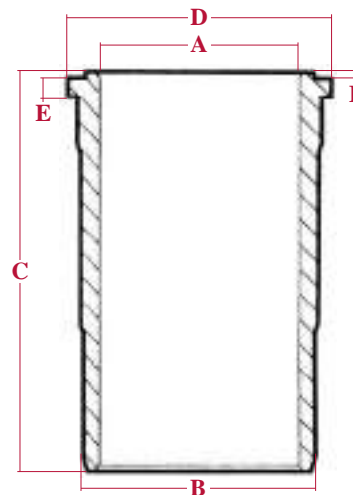
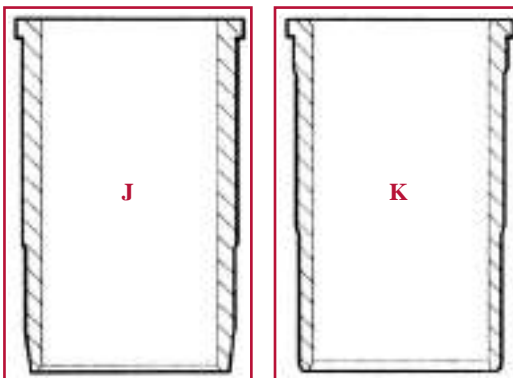

- A** : Bohrung (mm)
- B** : Durchmesser Aussen (mm)
- C** : Gesamthöhe (mm)
- D** : Durchmesser Kragen (mm)
- E** : Kragenhöhe (mm)
- F** : Feuersteghöhe (mm)

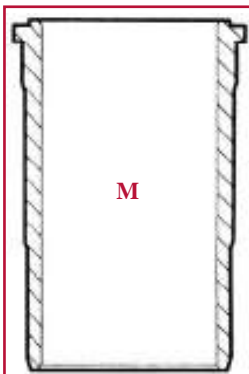

Bestell-Nr.	Typ	A mm	B mm	C mm	D mm	E mm	F mm
25/35-42	J	85.72	93.64	179.39	101.70	5.82	-
25/35-44	K	88.90	93.65	185.73	101.70	5.82	-
25/35-62	M	98.42	110.75	201.10	119.00	7.70	1.10
25/35-63	M	98.42	110.75	216.10	119.00	7.70	1.10
25/35-66	M	100.00	110.75	216.10	119.00	7.70	1.10











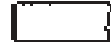
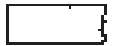



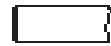

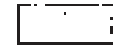



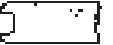
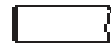
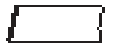

Wir vertreiben keine Originalteile.
 Die Nummern dienen lediglich als Beschreibung.

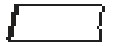

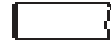
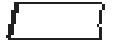
"THE RELIABLE SERVICE"

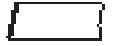

KOLBENRINGE
Motoren IH

Bestell-Nr.	Motoren	Bohrung Ø					
25/34-42	BD144	85.72	 CP2 2.38	 P1 2.38	 P1 2.38	 SS 4.76	 SS 4.76
25/34-44	BD154	88.90	 CP1 2.38	 P2 2.38	 P2 2.38	 SS 4.76	 SS 4.76
25/34-60	D155, D206, D310, D179, D239, D358	98.42	 MK1 3.00	 N1 3.17	 P1 3.17	 BEH 4.76	
25/34-62		98.42	 CP1 3.17	 CT2 2.38	 CBEH 4.76		
25/34-65		98.42	 CK1 3.00	 CT2 2.38	 CBEH 4.76		
25/34-66	D246	100.00	 CP1 3.17	 CT2 2.38	 CBEH 4.76		
25/34-67	D268	100.00	 CK1 3.00	 CT2 2.38	 CBEH 4.76		
25/34-114	DT268 DT402	100.00	 CK1 3.00	 CK1 3.00	 CBEH 4.76		

- BEH** : Ölabbreifer mit Spanneder
CBEH : Ölabbreifer, verchromt, mit Spanneder
CP1 : Kolbenring, rechteckig, verchromt
CP2 : Kolbenring, rechteckig, mit abgesetzter Top-Kante
CK1 : Kolbenring, trapezförmig, verchromt
CT2 : Kolbenring, verchromt, mit abgesetzter Top-Kante
MK1 : Kolbenring, trapezförmig Molybden
N1 : Nasenring
P1 : Rechteckig
P2 : Kolbenring, rechteckig, mit abgesetzter Top-Kante

Wir vertreiben keine Originalteile.
Die Nummern dienen lediglich als Beschreibung.



"THE RELIABLE SERVICE"

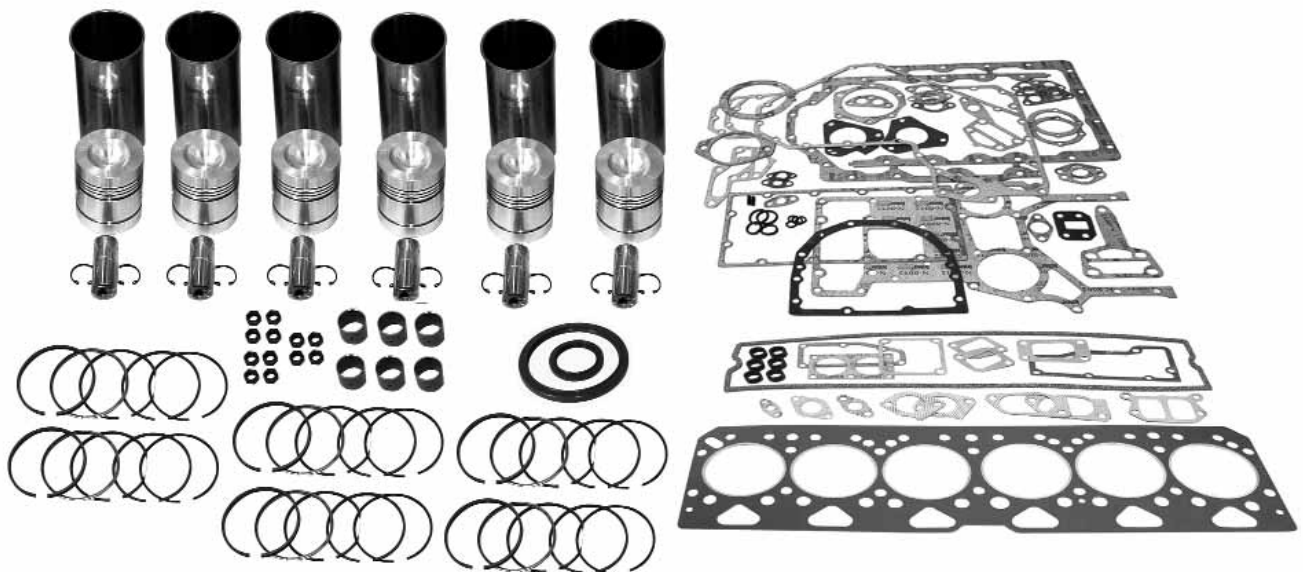

KOMPLETTER MOTORREPARATURSATZ

Bestell-Nr.	Motoren	Bohrung	Ø Kolbenbolzen	Schleppertyp
25/30-120	D155	98.4 mm	36.0 mm	353, 383, 385, 395, 423, 433, 440, 453, 533, 540, 3210
25/30-121	D206			474, 584, 585, 595, 624, 644, 645, 654, 733, 740, 3230
25/30-122	D310			946, 955
25/30-123	D179			248, 454, 464, 484, 485, 495, 523, 553, 633, 640, 2400, 3220
25/30-124	D239			574, 674, 684, 685, 695, 724, 743, 744, 745, 833, 840, 940, 4210
25/30-125	D358			956, 1046, 1055, 1056
25/30-126	DT239			38.0 mm
25/30-127	DT358	1246, 1255		
25/30-128	D246	100.0 mm	36.0 mm	278, 784, 785, 795, 824, 844, 4220
25/30-129	D268			844S, 845, 884, 885, 895, 4230
25/30-190	DT402			38.0 mm

Beinhaltet: Kolben & Buchsensätze (Ringträgerkolben) mit Dichtungen, Kopfdichtungssatz, Ölwanndichtung.

Wir vertreiben keine Originalteile.
 Die Nummern dienen lediglich als Beschreibung.



"THE RELIABLE SERVICE"

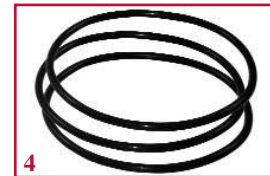

KOLBEN, BUCHSEN & RINGE
Motoren Cummins

1	2	3	4	Bohrung	Typ	Schleppertyp
Kolben & Ringe	Satz Kolbenringe	Buchse (halbfertig)	Buchsendichtung			
Motoren 4 Zyl.						
25/32-91 (A77733, A77730)	25/34-91 (A77727, J802746)	25/36-91 (J904166) Ausbohrung des Motorblocks		102 mm	4T390	5120, 5220
25/32-91 A (+ 0.5 mm) (A77734, A77519)	25/34-91 A (+ 0.5 mm) (A77728, J802422)					
25/32-91 B (+ 1.0 mm) (A77735, A77520)	25/34-91 B (+ 1.0 mm) (A77729, J802423)					
Motoren 6 Zyl.						
25/32-92 (A77410)	25/34-92 (A77401)	25/36-91 (J904166) Ausbohrung des Motorblocks		102 mm	6-590	5130, 5230
25/32-92 A (+ 0.5 mm) (A77411)	25/34-92 A (+ 0.5 mm) (A77463)					
25/32-92 B (+ 1.0 mm) (A77412)	25/34-92 B (+ 1.0 mm) (A77464)					
25/32-91 (A77733, A77730)	25/34-91 (A77727, J802746)			102 mm	6T590	5140, 5150, 5240, 5250
25/32-91 A (+ 0.5 mm) (A77734, A77519)						
25/32-91 B (+ 1.0 mm) (A77735, A77520)						
25/32-93 (J802747 + J919053 + J934047)	25/34-91 A (+ 0.5 mm) (A77728, J802422)			102 mm	6T590	MX100, MX110, MX120, MX135, MX150, MX170
25/32-93 A (+ 0.5 mm) (J802764)	25/34-91 B (+ 1.0 mm) (A77729, J802423)					
25/32-93 B (+ 1.0 mm) (J802765)						

Wir vertreiben keine Originalteile.
 Die Nummern dienen lediglich als Beschreibung.



"THE RELIABLE SERVICE"



KOLBEN, BUCHSEN & RINGE

Motoren Cummins

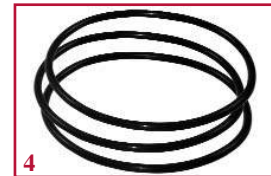

1	2	3	4	Bohrung	Typ	Schleppertyp
Kolben & Ringe	Satz Kolbenringe	Buchse	Buchsendichtung			
Motoren 6 Zyl.						
25/32-283 (A77771)	25/34-283 (A77562, A77744, A77802, J802429)	25/35-284 (J919937) (E = 4 mm)	25/38-283 (J907177)	114 mm	6T830	7110, 7120, 7130, 7140, 7150, 7210, 7220, 7230, 7240, 7250, 9110, 9130, 9210, 9230, 9240
25/32-285 (A77853)		25/35-283 (J907792) (E = 6 mm)		114 mm	6T830	7210, 7220, 7230, 7240, 7250, 8910, 8920, 8930, 8940, 8950, 9310, 9330, MX180, MX200, MX220, MX240, MX255, MX270

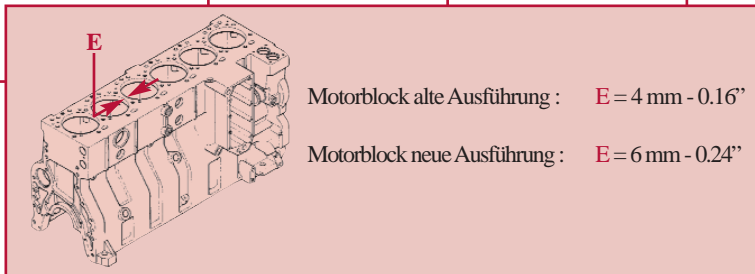

Mähdrescher						
	25/34-91 (A77727, J802746) 25/34-91 A (+ 0.5 mm) (A77728, J802422) 25/34-91 B (+ 1.0 mm) (A77729, J802423)					
25/32-283 (A77771) Kolben (J901597, J934046) Welle	25/34-283 (A77562, A77744, A77802, J802429)	25/35-284 (J919937) (E = 4 mm)	25/38-283 (J907177)	102 mm	6T590	1640, 1644, 2144, 2344
25/32-285 (A77853) Kolben (J901597, J934046) Welle		25/35-283 (J907792) (E = 6 mm)		114 mm	6T830	1660, 1666, 1670, 1680, 1688 2166 (⇒ 176199)
				114 mm	6T830	2166 (176200 ⇒) 2188, 2365, 2366, 2388

Wir vertreiben keine Originalteile.
Die Nummern dienen lediglich als Beschreibung.



"THE RELIABLE SERVICE"



KOLBEN

Motoren Cummins

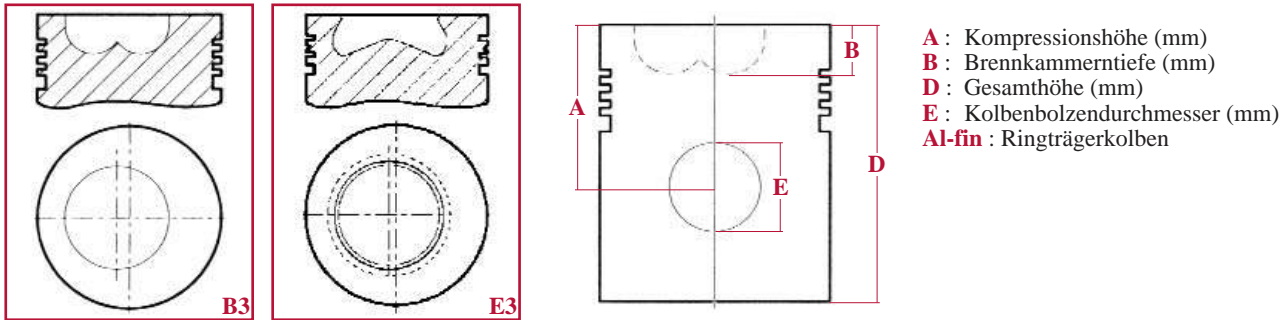

A : Kompressionshöhe (mm)
B : Brennkammertiefe (mm)
D : Gesamthöhe (mm)
E : Kolbenbolzendurchmesser (mm)
Al-fin : Ringträgerkolben

Bestell-Nr.	Motoren	Bohrung Ø	Typ	Ringe	Al-fin	A mm	B mm	D mm	E mm
25/32-91	4T390, 6T390	101.80	B3	3	Ja	71.50	17.65	105.36	40.00
25/32-92	6-590	101.80	B3	3	Nein	68.00	19.40	105.36	40.00
25/32-93	6T590	102.00	E3	3	Ja	71.78	22.00	105.60	40.00

KOLBENRINGE

Bestell-Nr.	Motoren	Bohrung Ø					
25/34-91	4T390, 6T390	101.80	CK1 2.85	CP3 2.34	CBEH 3.97		
25/34-92	6-590	101.80	CP1 2.38	CP3 2.34	CBEH 3.97		

CBEH : Ölabbstreifring, verchromt, mit Spannfeder
CP1 : Kolbenring, rechteckig, verchromt
CP3 : Kolbenring, rechteckig, verchromt mit innen abgesetzter Top-Kante
CK1 : Kolbenring, trapezförmig, verchromt

Wir vertreiben keine Originalteile.
 Die Nummern dienen lediglich als Beschreibung.



"THE RELIABLE SERVICE"

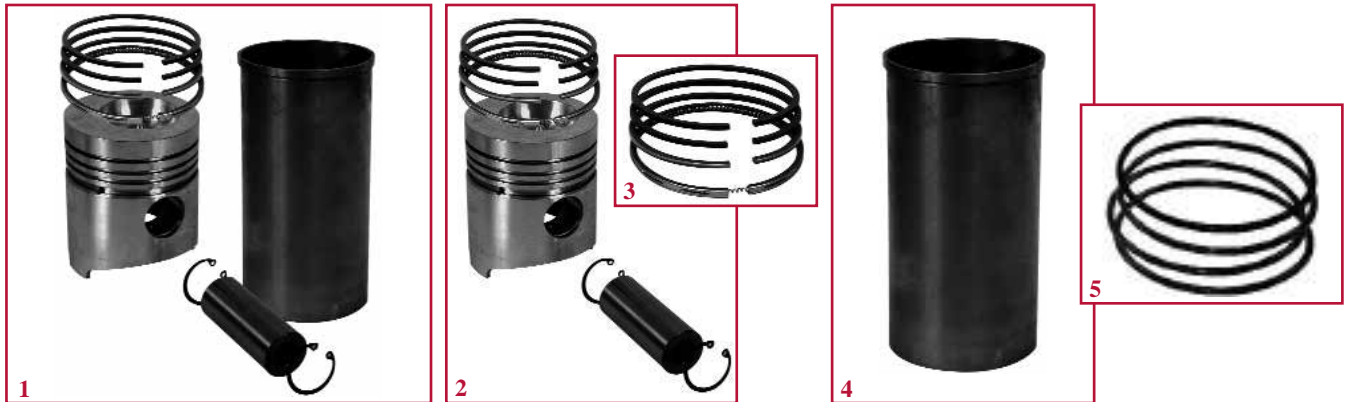

KOLBEN, BUCHSEN & RINGE
Motoren MWM

1	2	3	4	5	Bohrung	Typ	Schleppertyp
KBR-Sätze (A)	Kolben & Ringe	Satz Kolbenringe	Buchse	Dichtung			
Motoren 3 Zyl.							
25/31-278	25/32-278 (130142030703, 130142030701)	25/34-278 (130100030708)	25/35-278 (130100040723)	25/37-278 (2x130100041001 + 2x130100041002)	105	D 226-B3	C55, C55A
25/31-279	25/32-279 (130182030702, 130182030705)				105	TD 226-B3	C64, C64A, C70A CS68, CS75 (⇒ 12/98)
Motoren 4 Zyl.							
25/31-279	25/32-279 (130182030702, 130182030705)	25/34-278 (130100030708)	25/35-278 (130100040723)	25/37-278 (2x130100041001 + 2x130100041002)	105	TD 226-B4	CS78, CS86, CS94 (⇒ 12/98)

(A) Incl. Zylinderbuchsenabdichtungen



KOLBEN

Motoren MWM

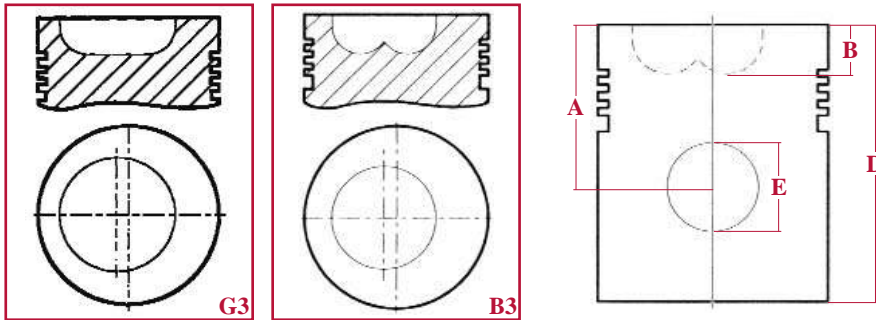

- A** : Kompressionshöhe (mm)
- B** : Brennkerntiefe (mm)
- D** : Gesamthöhe (mm)
- E** : Kolbenbolzendurchmesser (mm)
- Al-fin** : Ringträgerkolben

Bestell-Nr.	Motoren	Bohrung Ø	Typ	Ringe	Al-fin	A mm	B mm	D mm	E mm
25/32-278	D 226-B3	105	G3	3	Ja	66.4	20.8	102.4	35
25/32-279	TD 226-B3 TD 226-B4	105	B3	3	Ja	66.4	21.7	102.4	35

BUCHSE

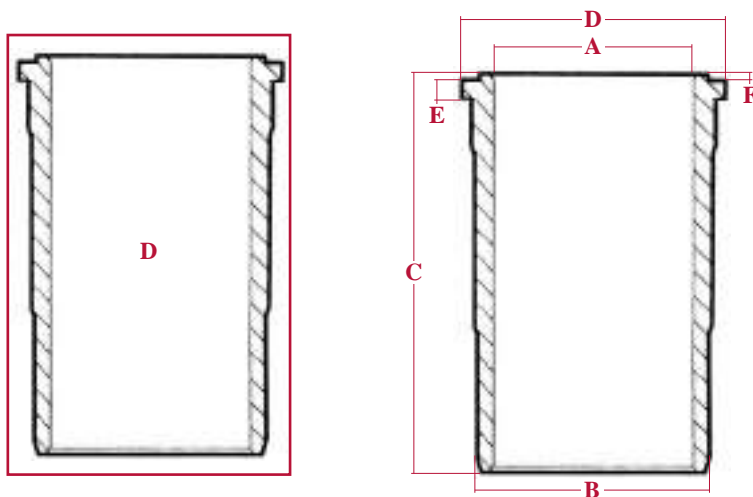

- A** : Bohrung (mm)
- B** : Durchmesser Aussen (mm)
- C** : Gesamthöhe (mm)
- D** : Durchmesser Kragen (mm)
- E** : Kragenhöhe (mm)
- F** : Feuersteghöhe (mm)

Bestell-Nr.	Typ	A mm	B mm	C mm	D mm	E mm	F mm
25/35-278	D	105	115	213	123	8	1

KOLBENRINGE

Bestell-Nr.	Motoren	Bohrung Ø								
25/34-278	D 226-B3 TD 226-B3 TD 226-B4	105 mm		3.00		2.00		2.00		4.00

- CBEH** : Ölabbstreifring, verchromt, mit Spannfeder
- CK1** : Kolbenring, trapezförmig, verchromt
- N1** : Nasenring
- P3** : Kolbenring, mit abgesetzter Top-Kante

Wir vertreiben keine Originalteile.
 Die Nummern dienen lediglich als Beschreibung.



"THE RELIABLE SERVICE"

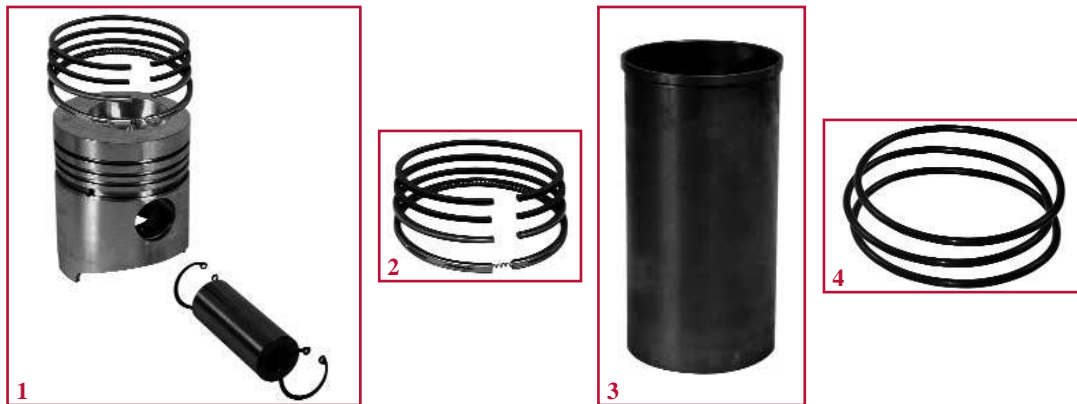

KOLBEN, BUCHSEN & RINGE
Motoren Sisu

1	2	3	4	Bohrung	Typ	Schleppertyp
Kolben & Ringe	Satz Kolbenringe	Buchse	Buchsendichtung			
Motoren 3 Zyl.						
25/32-275 (354138A1)	25/34-275 (132000030702)	25/35-275 (162000040704, 162000040763, 836647420)	25/37-275 (2 x 162000040705 836647502 + 1 x 162000040706 836647503)	108 mm	320D	CS68, CS75 (1/99 ⇒)
Motoren 4 Zyl.						
25/32-275 (354138A1)	25/34-275 (132000030702)	25/35-275 (162000040704, 162000040763, 836647420)	25/37-275 (2 x 162000040705 836647502 + 1 x 162000040706 836647503)	108 mm	420D	CS78, CS86, CS94 (1/99 ⇒)
25/32-276 (162000030700, 836640073)	25/34-276 (162000030701, 836640078)					CS100, CS110
Motoren 6 Zyl.						
25/32-275 (354138A1)	25/34-275 (132000030702)	25/35-275 (162000040704, 162000040763, 836647420)	25/37-275 (2 x 162000040705 836647502 + 1 x 162000040706 836647503)	108 mm	620D	CS120 CS130 (0075001 ⇒) CVX120, CVX130, CVX1135, CVX1145
25/32-276 (162000030700, 836640073)	25/34-276 (162000030701, 836640078)					CS130 (⇒ 0015200) CS150, CVX150, CVX170
25/32-277 (162000030730)						CVX1155, CVX1170, CVX1190

Wir vertreiben keine Originalteile.
Die Nummern dienen lediglich als Beschreibung.

"THE RELIABLE SERVICE"

KOLBEN

Motoren Sisu / Sisu motoren

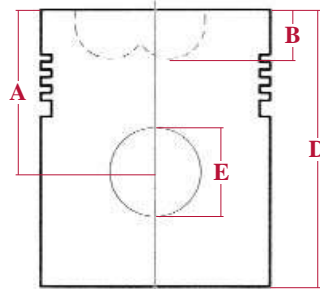
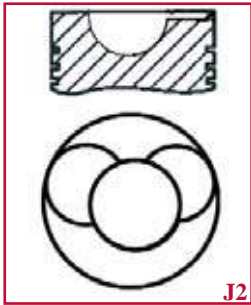

- A** : Kompressionshöhe (mm)
- B** : Brennkammertiefe (mm)
- D** : Gesamthöhe (mm)
- E** : Kolbenbolzendurchmesser (mm)
- Al-fin** : Ringträgerkolben

Bestell-Nr.	Motoren	Bohrung Ø	Typ	Ringe	Al-fin	A mm	B mm	D mm	E mm
25/32-275	320D, 420D, 620D	108 mm	J2	3	Nein	70.70	17.95	106.68	40.00
25/32-276	420D, 620D		J2	3	Ja	70.48	18.72	106.68	40.00

BUCHSE

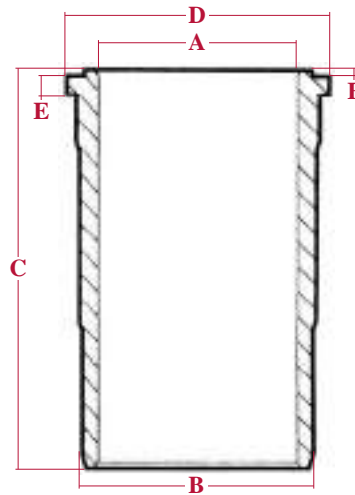
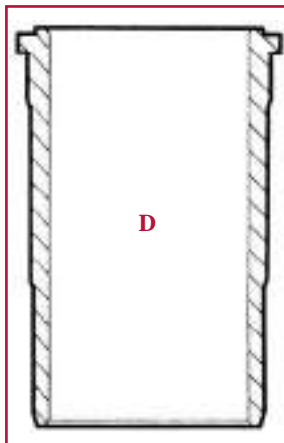

- A** : Bohrung (mm)
- B** : Durchmesser Aussen (mm)
- C** : Gesamthöhe (mm)
- D** : Durchmesser Kragen (mm)
- E** : Kragenhöhe (mm)
- F** : Feuersteghöhe (mm)

Bestell-Nr.	Typ	A mm	B mm	C mm	D mm	E mm	F mm
25/35-275	D	107.80	117.08	218.00	131.72	9.06	0.98

KOLBENRINGE

Bestell-Nr.	Motoren	Bohrung Ø					
25/34-275	320D, 420D, 620D	108 mm	CP1 2.50	P4 2.45	CBEH 4.00		
25/34-276	420D, 620D	108 mm	CK1 3.00	P1 2.50	CBEH 4.00		

- CBEH** : Ölabstreifring, verchromt, mit Spannfeder
- CP1** : Kolbenring, rechteckig, verchromt
- CK1** : Kolbenring, trapezförmig, verchromt
- P1** : Rechteckig
- P4** : Kolbenring mit Trapezkante

Wir vertreiben keine Originalteile.
 Die Nummern dienen lediglich als Beschreibung.



"THE RELIABLE SERVICE"



KOLBEN, BUCHSEN & RINGE
Motoren Perkins



1	2	3	4			
Satz	Kolben	Satz Kolbenringe	Buchsen	Bohrung	Typ	Schleppertyp
Motoren 3 Zyl.						
25/31-272	25/33-272 (A) (356695A1, 130300030711)	25/34-272 (296244A1, 130300030720)	25/36-272 (C) (296157A1, 130300040725)	95 mm	903.27	C50, CS48, CS52, CX50
25/31-273	25/33-273 (B) (130300030721)	25/34-273 (296641A1, 130300030723)		95 mm	903.27T	C60, CS58, CS63, CX60
Motoren 4 Zyl.						
25/31-61	25/33-61 (3118170R91)	25/34-61 (3118131R1)	25/35-61 (D) (796227R1)	98.48 mm	A4.212	475
25/31-274 (D)	25/33-274 (314399A1)	25/34-100 (293181A1)	25/35-274 (D) (314649A1, 3135X062) 25/36-274 (C) (293041A1)	100 mm	1004.4T	C80, C90, CX80, CX90, CX100, MX80C, MX90C, MX100C

- (A) High Quality Kolben, ersetzt 410904A1, 296259A1, 130300030712
 (B) High Quality Kolben, ersetzt 296640A1, 130300030722
 (C) Buchse (halbfertig)
 (D) Buchse (fertig)

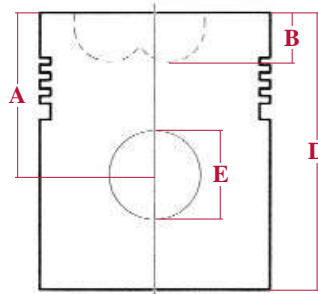
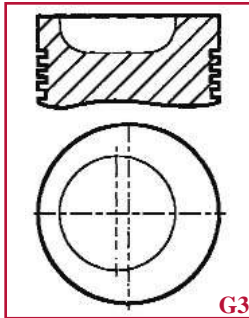
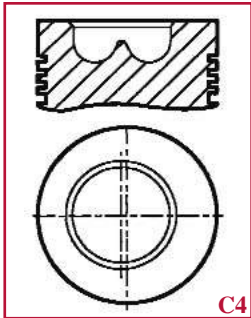

KOLBEN

Motoren Perkins



- A** : Kompressionshöhe (mm)
- B** : Brennkammerentiefe (mm)
- D** : Gesamthöhe (mm)
- E** : Kolbenbolzendurchmesser (mm)
- Al-fin** : Ringträgerkolben

Bestell-Nr.	Motoren	Bohrung Ø	Typ	Ringe	Al-fin	A mm	B mm	D mm	E mm
25/33-61	A4.212	98.48 mm	G3	3	Nein	76.53	19.57	116.13	34.92
25/33-272	903.27	94.30 mm	C4	3	Nein	63.36	20.45	99.76	31.72
25/33-273	903.27T	94.31 mm	C4	3	Ja	63.02	21.00	99.65	31.80
25/33-274	1004.4T	100.00 mm	C4	3	Ja	70.32	21.50	108.26	39.69

BUCHSE

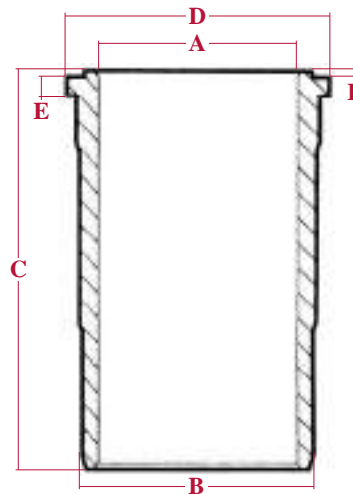
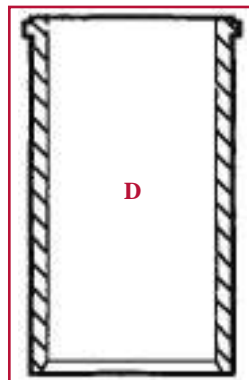
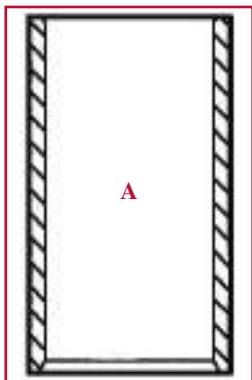

- A** : Bohrung (mm)
- B** : Durchmesser Aussen (mm)
- C** : Gesamthöhe (mm)
- D** : Durchmesser Kragen (mm)
- E** : Kragenhöhe (mm)
- F** : Feuersteghöhe (mm)

Bestell-Nr.	Typ	A mm	B mm	C mm	D mm	E mm	F mm
Buchsen							
25/35-61	D	98.48	103.19	227.28	106.45	3.86	0.89
25/35-274	D	100.00	104.11	228.00	107.34	3.90	0.89
Buchse (halbfertig)							
25/36-272	A	93.55	96.70	215.00	-	-	-
25/36-274	D	99.08	104.11	228.00	107.34	3.91	0.98

Wir vertreiben keine Originalteile.
 Die Nummern dienen lediglich als Beschreibung.











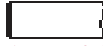

"THE RELIABLE SERVICE"

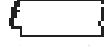

KOLBENRINGE

I

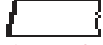
Motoren Perkins

Bestell-Nr.	Motoren	Bohrung					
25/34-61	A4.212	98.48 mm	 CP1 2.38	 CP2 2.38	 CBEH 6.35		
25/34-100	1004.4T	100.00 mm	 CK1 3.50	 TN1 2.50	 CBEH 3.50		
25/34-272	903.27	95.00 mm	 CK1 3.00	 T5 2.00	 CBEH 4.00		
25/34-273	903.27T	95.00 mm	 CT1 2.50	 T5 2.00	 CBEH 4.00		

- CBEH** : Ölabbstreifring, verchromt, mit Spannfeder
- CP1** : Kolbenring, rechteckig, verchromt
- CP2** : Kolbenring, rechteckig, mit abgesetzter Top-Kante
- CK1** : Kolbenring, trapezförmig, verchromt
- CT1** : Kolbenring, verchromt
- TN1** : Konischer Ring
- T5** : Konischer Kolbenring

Wir vertreiben keine Originalteile.
 Die Nummern dienen lediglich als Beschreibung.



"THE RELIABLE SERVICE"



KOLBEN, BUCHSEN & RINGE
Motoren Iveco



1	2	3	Bohrung	Motoren	Schleppertyp
Kolben	Satz Kolbenringe	Buchse (halbfertig)			
Motoren 3 Zyl.					
25/33-270 (1940174)	25/34-270 (1940172)	25/36-270 (4770654)	100 mm	8035.06	AVJ55, JX55
25/33-271 (1931002, 1931021, 1931202, 1931206)	25/34-271 (1931000, 1931019, 1931200, 1931204)	25/36-271 (4770623)	104 mm	8035.05	AVJ60, JX60, JX65, JX70, JX1060C, JX1070C, JX1075C, VJ60
Motoren 4 Zyl.					
25/33-270 (1940174)	25/34-270 (1940172)	25/36-270 (4770654)	100 mm	8045.06	AVJ70, JX70U, JX75, VJ70
25/33-271 (1931002, 1931021, 1931202, 1931206)	25/34-271 (1931000, 1931019, 1931200, 1931204)	25/36-271 (4770623)	104 mm	8045.05	JX80, JX80U, JX85, JX90, JX90U, JX95, JX100U, VJ80

Wir vertreiben keine Originalteile.
 Die Nummern dienen lediglich als Beschreibung.

"THE RELIABLE SERVICE"

KOLBEN

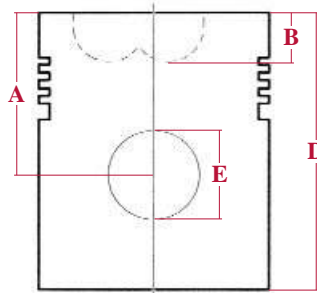
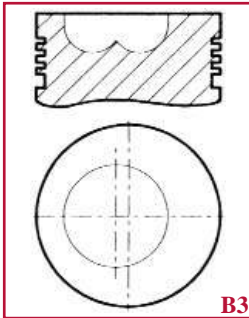
Motoren Iveco



- A** : Kompressionshöhe (mm)
- B** : Brennkerntiefe (mm)
- D** : Gesamthöhe (mm)
- E** : Kolbenbolzendurchmesser (mm)
- Al-fin** : Ringträgerkolben

Bestell-Nr.	Motoren	Bohrung Ø	Typ	Ringe	Al-fin	A mm	B mm	D mm	E mm
25/33-270	8035.06 8045.06	100 mm	B3	3	Nein	65.15	22.70	108.50	38.00
25/33-271	8035.05 8045.05	104 mm	B3	3	Ja	65.15	22.50	108.50	38.00

BUCHSE

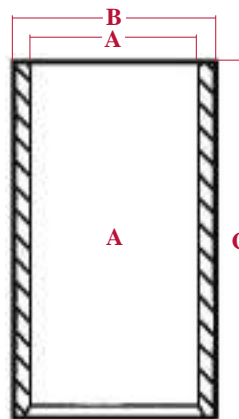

- A** : Bohrung (mm)
- B** : Durchmesser Aussen (mm)
- C** : Gesamthöhe (mm)

Bestell-Nr.	Typ	A mm	B mm	C mm
25/36-270	A	100.00	103.06	196.00
25/36-271	A	104.00	107.10	198.00

KOLBENRINGE

Bestell-Nr.	Motoren	Bohrung Ø					
25/34-270	8035.06 8045.06	100 mm	CPI 2.5	N1 2.5	CBEH 4.0		
25/34-271	8035.05 8045.05	104 mm	CPI 2.5	N1 2.5	CBEH 4.0		

- CBEH** : Ölabbstreifer, verchromt, mit Spannfeder
- CPI** : Kolbenring, rechteckig, verchromt
- N1** : Nasenring

Wir vertreiben keine Originalteile.
Die Nummern dienen lediglich als Beschreibung.



"THE RELIABLE SERVICE"



KOLBEN, BUCHSEN & RINGE
Motoren Ford

1

2

1	2	Bohrung	Motor	Schleppertyp
Satz Kolbenringe	Buchse (halbfertig)			
Motoren 6 Zyl.				
25/34-280 (87802835)	25/36-280 (83998292)	111.76 mm	675/TA	MXM120, MXM130, MXM135, MXM140, MXM150, MXM155, MXM165, MXM175, MXM180, MXM190

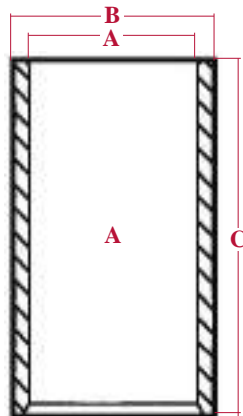
BUCHSE

A : Bohrung (mm)
B : Durchmesser Aussen (mm)
C : Gesamthöhe (mm)

Bestell-Nr.	Typ	A mm	B mm	C mm
25/36-280	A	111.76	114.40	205.60

KOLBENRINGE

Bestell-Nr.	Motor	Bohrung Ø					
25/34-280	675/TA	111.76	CK3 3.00	N1 2.36	CBEH 2.95		

CBEH : Ölabbstreifring, verchromt, mit Spannfeder
CK3 : Kolbenring rechteckig verchromt, mit innen abgesetzter Top-Kante
N1 : Nasenring

Wir vertreiben keine Originalteile.
Die Nummern dienen lediglich als Beschreibung.

"THE RELIABLE SERVICE"

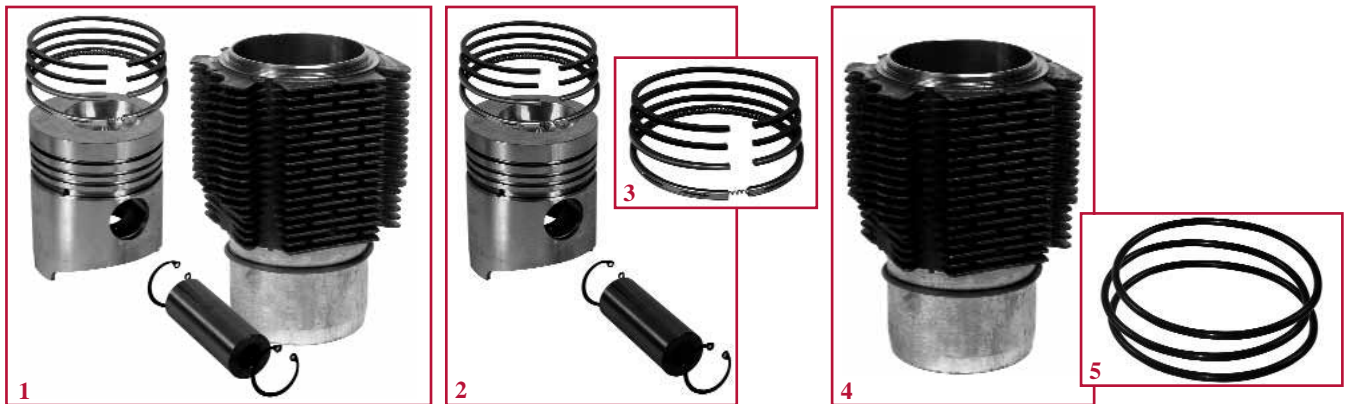
KOLBEN, BUCHSEN & RINGE
Motoren Same

1	2	3	4	5			
KBR-Sätze (A)	Kolben & Ringe	Satz Kolbenringe	Buchse	Buchsendichtung	Bohrung	Typ	Schleppertyp
Motoren 3 Zyl.							
25/31-281	25/32-281 (1966438C1)	25/34-281 (1966437C1)	25/35-281 (124439A1)	25/38-281 (124442A1)	105 mm	1000.3A	2120, 2130, 2120 PRO, 2130 PRO
25/31-282	25/32-282 (440009A1)		25/35-281 (124439A1)	25/38-281 (124442A1)	105 mm	1000.3A	PJ55, PJN55, PJV55
Motoren 4 Zyl.							
25/31-281	25/32-281 (1966438C1)	25/34-281 (1966437C1)	25/35-281 (124439A1)	25/38-281 (124442A1)	105 mm	1000.4A	2140, 2150, 2140 PRO, 2150 PRO
25/31-282	25/32-282 (440009A1)		25/35-281 (124439A1)	25/38-281 (124442A1)	105 mm	1000.4A	PJ65, PJN65, PJV65, PJ75, PJN75, PJV75

(A) Incl. Zylinderbuchsenabdichtungen

Wir vertreiben keine Originalteile.
Die Nummern dienen lediglich als Beschreibung.



"THE RELIABLE SERVICE"



KOLBEN

Motoren Same

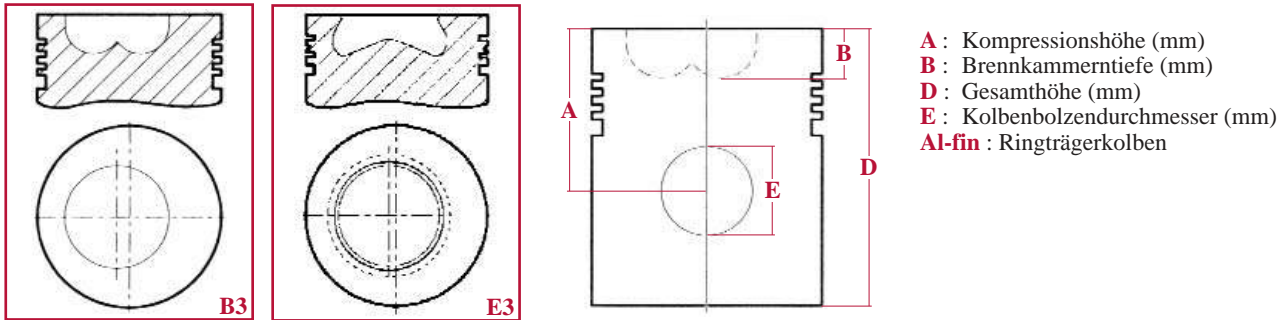

- A** : Kompressionshöhe (mm)
- B** : Brennkammertiefe (mm)
- D** : Gesamthöhe (mm)
- E** : Kolbenbolzendurchmesser (mm)
- Al-fin** : Ringträgerkolben

Bestell-Nr.	Motoren	Bohrung Ø	Typ	Ringe	Al-fin	A mm	B mm	D mm	E mm
25/32-281	1000.3A 1000.4A	105.00	B3	3	Nein	57.25	19.55	97.25	35.00
25/32-282	1000.3A 1000.4A	105.00	E3	3	Nein	57.25	19.25	97.10	35.00

BUCHSE

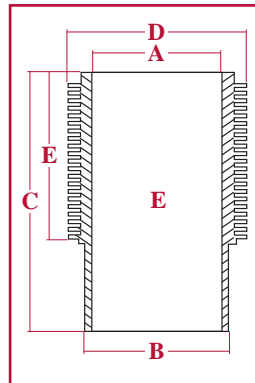

- A** : Bohrung (mm)
- B** : Durchmesser Aussen (mm)
- C** : Gesamthöhe (mm)
- D** : Durchmesser Kragen (mm)
- E** : Kragenhöhe (mm)

Bestell-Nr.	Typ	A mm	B mm	C mm	D mm	E mm	F mm
25/35-281	E	105.00	119.80	194.40	144.00	67.00	-

KOLBENRINGE

Bestell-Nr.	Motoren	Bohrung Ø					
25/34-281	1000.3A 1000.4A	105.00	P2 2.95	P1 2.45	CBEH 4.00		

Wir vertreiben keine Originalteile.
 Die Nummern dienen lediglich als Beschreibung.



"THE RELIABLE SERVICE"

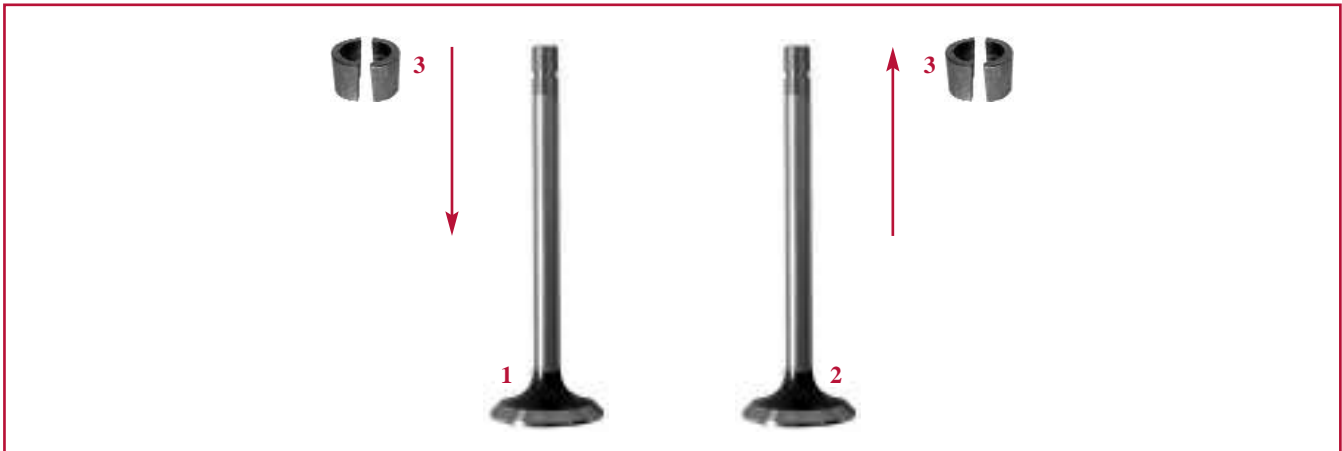

EINZELTEILE FÜR ZYLINDERKOPF
Motoren IH - Alte Serie

1	2	3	Motor	Schleppertyp
Einlassventil	Auslassventil	Klemmkeile		
Motoren 2 Zyl.				
25/42-72 (713384R2) Ø 36 mm - L = 148 mm	25/43-72 (713385R2) Ø 32 mm - L = 148 mm	25/46-72 (713386R1, 713991R91)	D66	D212, D214, D215
			D74	D217, D219
Motoren 3 Zyl.				
25/42-72 (713384R2) Ø 36 mm - L = 148 mm	25/43-72 (713385R2) Ø 32 mm - L = 148 mm	25/46-72 (713386R1, 713991R91)	D99	D320, D322
			D111	D324, D326
Motoren 4 Zyl.				
25/42-72 (713384R2) Ø 36 mm - L = 148 mm	25/43-72 (713385R2) Ø 32 mm - L = 148 mm	25/46-72 (713386R1, 713991R91)	D132	D430, D432, D440
25/42-73 (717374R1) Ø 36 mm - L = 152 mm	25/43-73 (717375R1) Ø 32 mm - L = 152 mm		D148	D436, D438, D439

Ø = Ventiltellergrösse
 L = Gesamtlänge

Wir vertreiben keine Originalteile.
 Die Nummern dienen lediglich als Beschreibung.

"THE RELIABLE SERVICE"



EINZELTEILE FÜR ZYLINDERKOPF
Motoren IH

1	2	3	4	Motor	Schleppertyp
Führung - Einlass	Führung - Auslass	Einlassventil	Auslassventil		
Motoren 3 Zyl.					
25/41-16 (3055022R2)	25/41-16 (3055022R2)	25/42-23 (3055055R2)	25/43-23 (3055056R2)	D155	353, 383, 385, 395, 423, 433, 440, 453, 533, 540, 3210
				D179	248, 454, 464, 484, 485, 495, 523, 553, 633, 640, 2400, 3220
Motoren 4 Zyl.					
25/41-12 (704455R1)	25/41-13 (704456R2)	25/42-21 (3040361R1)	25/43-21 (3043825R1)	BD144	B275, 276, 354
25/41-14 (3044492R1)	25/41-15 (3044493R2)			BD154	238, 374, 384, B414, 424, 434, 444
25/41-16 (3055022R2)	25/41-16 (3055022R2)	25/42-23 (3055055R2)	25/43-23 (3055056R2)	D206	474, 584, 585, 595, 624, 644, 645, 654, 733, 740, 3230
				D239	574, 674, 684, 685, 695, 724, 743, 744, 745, 833, 840, 940, 4210
				D246	278, 784, 785, 795, 824, 844, 4220
				D268	844S, 845, 884, 885, 895, 4230
Motoren 6 Zyl.					
25/41-16 (3055022R2)	25/41-16 (3055022R2)	25/42-23 (3055055R2)	25/43-23 (3055056R2)	D310	946, 955
				D358	956, 1046, 1055, 1056
		25/42-23 (3055055R2)	25/43-25 (3136915R2)	DT358	1255
				DT402	1455

Bestell-Nr.	Beschreibung	Motor	Schleppertyp	Abb.
Motoren 4 Zyl.				
25/40-43 (3044489R91)	Zylinderkopf	BD154	238, 374, 384, B414, 424, 434, 444	
25/6302-42 (708331R1)	Zylinderkopfschraube kurz			
25/6302-43 (708332R1)	Zylinderkopfschraube lang			
25/80-42 (3063934R4)	Nockenwelle			

Wir vertreiben keine Originalteile.
 Die Nummern dienen lediglich als Beschreibung.

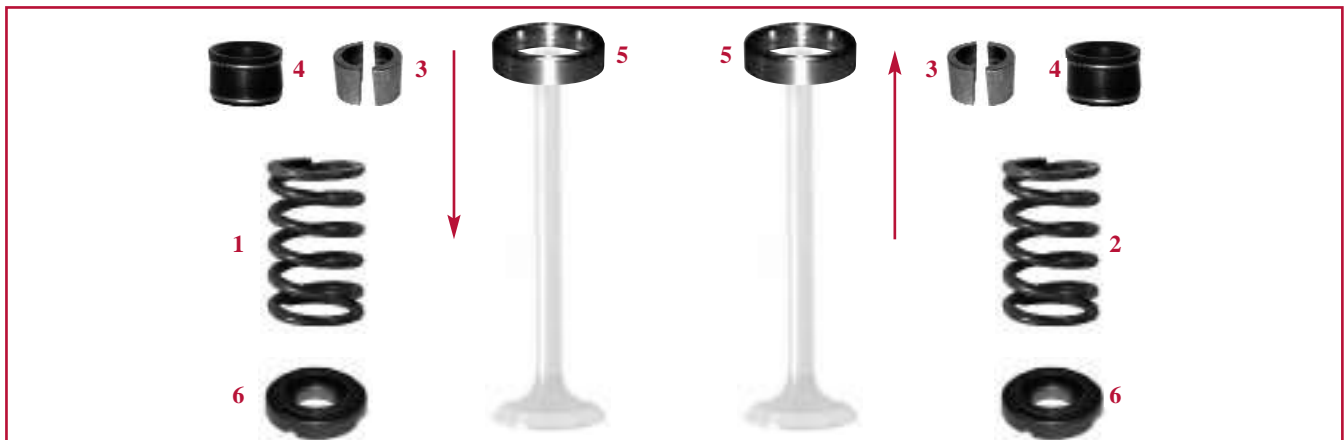

"THE RELIABLE SERVICE"

EINZELTEILE FÜR ZYLINDERKOPF
Motoren IH

1	2	3	4	5	6	Motor	Schleppertyp
Feder	Feder	Klemmkeile	Dichtung	Ventilring	Federkappe		
Motoren 3 Zyl.							
25/45-15 (3055060R1)	25/45-15 (3055060R1)	25/46-15 (3055057R91)	25/47-6 (3218399R1) per 6	25/48-15 (3132362R1)	25/49-15 (3055059R91)	D155	353, 383, 385, 395, 423, 433, 440, 453, 533, 540, 3210
						D179	248, 454, 464, 484, 485, 495, 523, 553, 633, 640, 2400, 3220
Motoren 4 Zyl.							
25/45-12 (710347R2)	25/45-12 (710347R2)					BD144	B275, 276, 354
25/44-13 (3044239R1)	25/45-13 (3044240R1)					BD154	238, 374, 384, B414, 424, 434, 444
25/45-15 (3055060R1)	25/45-15 (3055060R1)	25/46-15 (3055057R91)	25/47-6 (3218399R1) per 6	25/48-15 (3132362R1)	25/49-15 (3055059R91)	D206	474, 584, 585, 595, 624, 644, 645, 654, 733, 740, 3230
						D239	574, 674, 684, 685, 695, 724, 743, 744, 745, 833, 840, 940, 4210
						D246	278, 784, 785, 795, 824, 844, 4220
						D268	844S, 845, 884, 885, 895, 4230
Motoren 6 Zyl.							
25/45-15 (3055060R1)	25/45-15 (3055060R1)	25/46-15 (3055057R91)	25/47-6 (3218399R1) per 6	25/48-15 (3132362R1)	25/49-15 (3055059R91)	D310	946, 955
						D358	956, 1046, 1055, 1056
						DT358	1255
						DT402	1455

Wir vertreiben keine Originalteile.
Die Nummern dienen lediglich als Beschreibung.

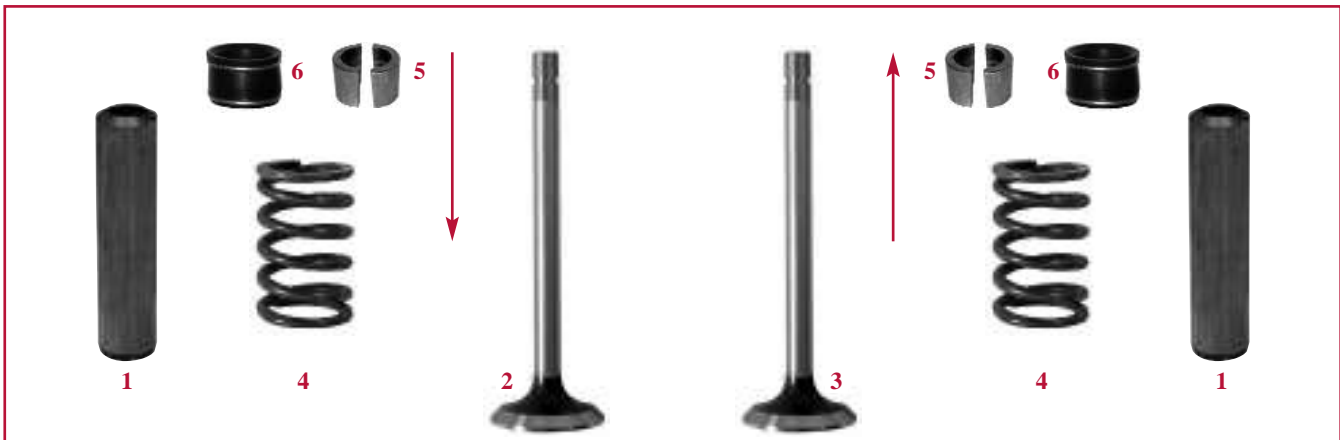
"THE RELIABLE SERVICE"

EINZELTEILE FÜR ZYLINDERKOPF
Motoren Cummins

1	2	3	4	5	6	Motor	Schleppertyp
Ventilführung	Einlassventil	Auslassventil	Feder	Klemmkeile	Dichtung		
Motoren 4 Zyl.							
	25/42-64 (J920867, J901117)	25/43-64 (J920868, J901607)		25/46-64 (J900250)	25/47-68 (J921640, J901097)	4T390	5120, 5220
Motoren 6 Zyl.							
						6-590	5130, 5230
	25/42-64 (J920867, J901117)	25/43-64 (J920868, J901607)		25/46-64 (J900250)	25/47-68 (J921640, J901097)	6T590	5140, 5150, 5240, 5250, MX100, MX110, MX120, MX135, MX150, MX170
25/41-78 (J901187, J923564)	25/42-78 (J902253, J915506, J924492)	25/43-78 (J902254, J921444)	25/45-78 (J906412, J991085)	25/46-78 (J901177)	25/47-78 (J915707)	6T830	7110, 7120, 7130, 7140, 7150, 7210, 7220, 7230, 7240, 7250, 8910, 8920, 8930, 8940, 8950, 9110, 9130, 9210, 9230, 9240, 9310, 9330, MX180, MX200, MX210, MX220, MX230, MX240
Mähdrescher							
25/41-78 (J901187, J923564)	25/42-78 (J902253, J915506, J924492)	25/43-78 (J902254, J921444)	25/45-78 (J906412, J991085)	25/46-78 (J901177)	25/47-78 (J915707)	6T830	1660, 1666, 1670, 1680, 1688, 2166, 2188, 2365, 2366, 2388, CF60, CF70, CF80

Wir vertreiben keine Originalteile.
Die Nummern dienen lediglich als Beschreibung.

"THE RELIABLE SERVICE"



EINZELTEILE FÜR ZYLINDERKOPF
Motoren MWM

1	2	3	4	5	6	Motor	Schleppertyp
Führung - Einlass	Führung - Auslass	Einlassventil	Auslassventil	Feder	Keile		
Motoren 3 Zyl.							
25/41-80 (130100040707)	25/41-81 (130100040706)	25/42-80 (130142050701) Ø 47 mm 45°	25/43-80 (130142050702) Ø 43 mm 45°	25/45-80 (5-1) (130100040702) Innen	25/46-80 (130100040710)	D 226-B 3	C55, C55A
		25/42-81 (130182050701) Ø 47 mm 30°	25/43-81 (130182050702) Ø 43 mm 30°	25/45-81 (5-2) (130100040703) Aussen		TD 226-B 3	C64, C64A, C70A CS68, CS75 (⇒ 12/98)
Motoren 4 Zyl.							
25/41-80 (130100040707)	25/41-81 (130100040706)	25/42-81 (130182050701) Ø 47 mm 30°	25/43-81 (130182050702) Ø 43 mm 30°	25/45-80 (5-1) (130100040702) Innen 25/45-81 (5-2) (130100040703) Aussen	25/46-80 (130100040710)	TD 226-B 4	CS78, CS86, CS94 (⇒ 12/98)

Bestell-Nr.	Beschreibung	Schleppertyp	OEM	Abb.
25/6306-3	Ventildeckel	D226, TD226	130100040704	

Wir vertreiben keine Originalteile.
 Die Nummern dienen lediglich als Beschreibung.

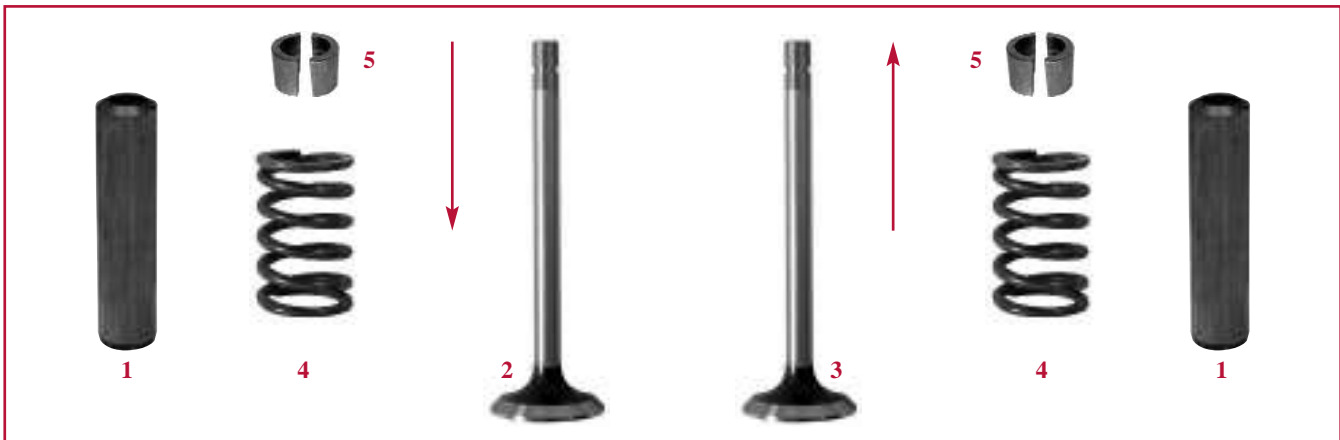

"THE RELIABLE SERVICE"

EINZELTEILE FÜR ZYLINDERKOPF
Motoren Sisu

1	2	3	4	5	Motor	Schleppertyp
Ventilführung	Einlassventil	Auslassventil	Feder	Keile		
Motoren 3 Zyl.						
25/41-77 (162000040717)	25/42-77 (162000050703)	25/43-77 (162000050702)	25/45-77 (162000050718)	25/46-77 (162000050704)	320D	CS68, CS75 (1/99 ⇨)
Motoren 4 Zyl.						
25/41-77 (162000040717)	25/42-77 (162000050703)	25/43-77 (162000050702)	25/45-77 (162000050718)	25/46-77 (162000050704)	420D	CS78, CS86, CS94 (1/99 ⇨)
					420D	CS100, CS110
Motoren 6 Zyl.						
25/41-77 (162000040717)	25/42-77 (162000050703)	25/43-77 (162000050702)	25/45-77 (162000050718)	25/46-77 (162000050704)	620D	CS120, CS130, CS150, CVX120, CVX130, CVX150, CVX170, CVX1135, CVX1145, CVX1155, CVX1170, CVX1190

Wir vertreiben keine Originalteile.
 Die Nummern dienen lediglich als Beschreibung.

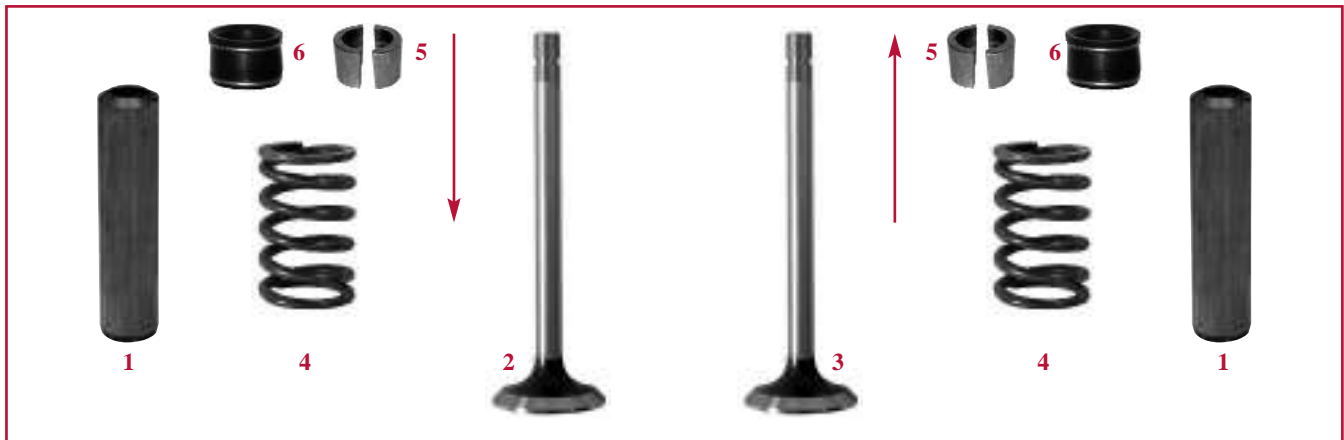
"THE RELIABLE SERVICE"

EINZELTEILE FÜR ZYLINDERKOPF
Motoren Perkins

1	2	3	4	5	6	Motor	Schleppertyp
Ventilführung	Einlassventil	Auslassventil	Feder	Keile	Dichtung		
Motoren 3 Zyl.							
25/41-83 (328340A1, 130300040706)	25/42-83 (296160A1, 130300040702)	25/43-83 (296159A1, 130300040703)	25/45-83 (296161A1, 130300040708)	25/46-83 (285222A1, 130300040710)	25/47-83 (359870A1, 387881A1, 285216A1, 130300040707)	903.27	C50, CS48, CS52, CX50
						903.27T	C60, CS58, CS63, CX60
Motoren 4 Zyl.							
	25/42-22 (A) (795730R1)	25/43-22 (A) (3118132R1)	25/44-14 (3118134R1) <i>Einlass</i> 25/45-14 (3118133R1) <i>Auslass</i>	25/46-22 (3118837R1)	25/47-5 (3118178R1, 3118179R1)	A4.212	475
25/41-84 (375827A1) <i>Einlass</i>	25/42-84 (311756A1)	25/43-84 (311761A1)	25/45-84 (311759A1)	25/46-84 (293047A1)	25/47-84 (322823A1, 293183A1) <i>Einlass</i>	1004.4T	C70, CX70
25/41-85 (334849A1) <i>Auslass</i>	25/42-85 (293751A1)	25/43-85 (293753A1)	25/45-85 (293124A1)		25/47-85 (322824A1, 293182A1) <i>Auslass</i>	1004.4T	C80, C90, CX80, CX90, MX80C, MX90C
	25/42-86 (293042A1)	25/43-86 (293043A1)				1004.4T	CX100, MX100C

Bestell-Nr.	Beschreibung	Schlepper	OEM	Abb.
Motoren 4 Zyl.				
25/53-6	Stößelstange	475, C70, C80, C90, CX70, CX80, CX90, CX100, MX80C, MX90C, MX100C	795728R1	
25/54-6	Ventilstößel	C70, C80, C90, CX70, CX80, CX90, CX100, MX80C, MX90C, MX100C	291962A1	

Wir vertreiben keine Originalteile.
Die Nummern dienen lediglich als Beschreibung.



"THE RELIABLE SERVICE"

NEBENANTRIEB

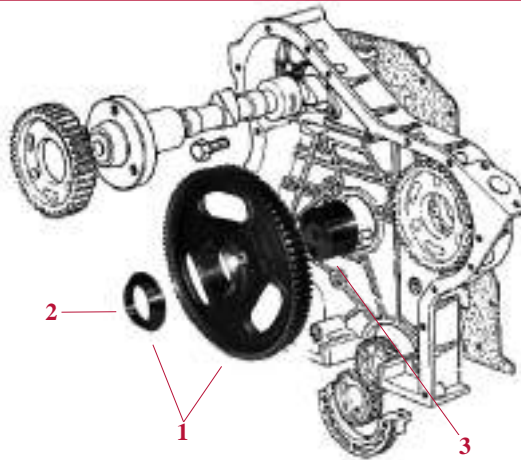
Motoren Perkins

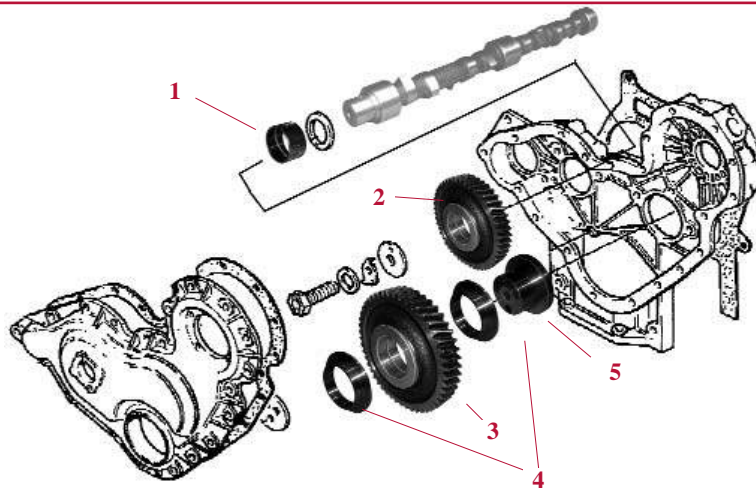

1	2	3	Motor	Schleppertyp
Zahnrad	Buchse	Bolzen		
Motoren 3 Zyl.				
25/82-17 (296235A1, 130300050722)	25/84-17 (296141A1, 130300050725)	25/83-17 (296086A1, 130300010739)	903.27	C50, CS48, CS52, CX50
			903.27T	C60, CS58, CS63, CX60



1	2	3	4	5	Motor	Schleppertyp
Buchse	Zahnrad	Zahnrad	Buchse	Bolzen		
Motoren 4 Zyl.						
25/56-18 (291951A1)	25/81-18 (281587A1)	25/82-18 (218370A1)	25/84-18 (F62671)	25/83-18 (218369A1)	1004.4T	C70, C80, C90, CX70, CX80, CX90, CX100, MX80C, MX90C, MX100C

Wir vertreiben keine Originalteile.
Die Nummern dienen lediglich als Beschreibung.



"THE RELIABLE SERVICE"

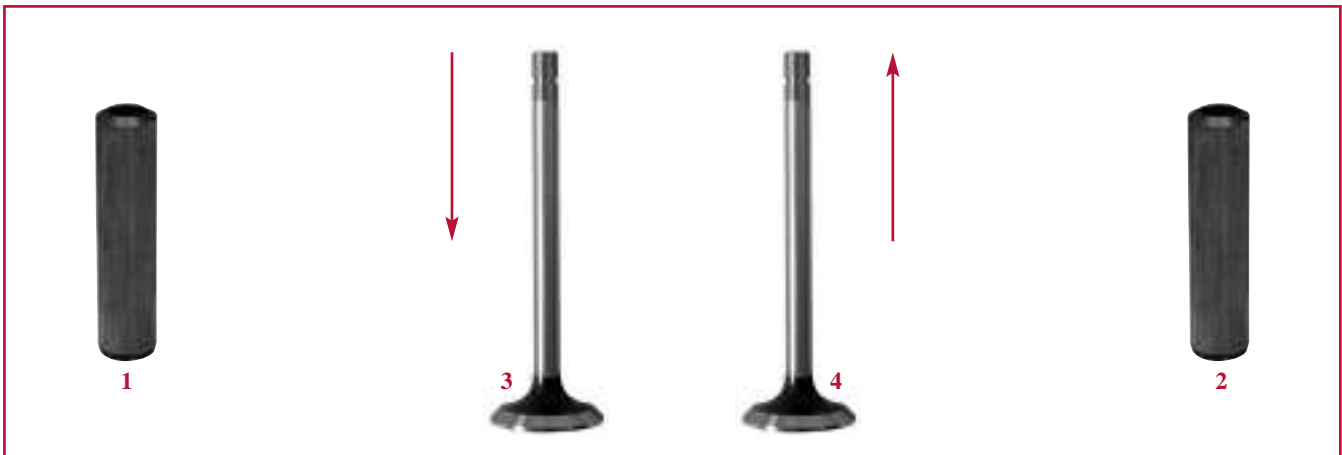

EINZELTEILE FÜR ZYLINDERKOPF
Motoren Iveco

1	2	3	4	Motor	Schleppertyp
Führung - Einlass	Führung - Auslass	Einlassventil	Auslassventil		
Motoren 3 Zyl.					
25/41-76 (4802126)	25/41-76 (4802126)	25/42-76 (4824417, 99432652, 98403097, 500300570)	25/43-76 (99432717, 500300597)	8035.06	AVJ55, JX55
				8035.05	AVJ60, JX60, JX65, JX70, JX1060C, JX1070C, JX1075C, VJ60
Motoren 4 Zyl.					
25/41-76 (4802126)	25/41-76 (4802126)	25/42-76 (4824417, 99432652, 98403097, 500300570)	25/43-76 (99432717, 500300597)	8045.06	AVJ70, JX70U, JX75, VJ70
				8045.05	JX80, JX85, JX90, JX95, JX80U, JX90U, JX100U, VJ80

Wir vertreiben keine Originalteile.
Die Nummern dienen lediglich als Beschreibung.

"THE RELIABLE SERVICE"

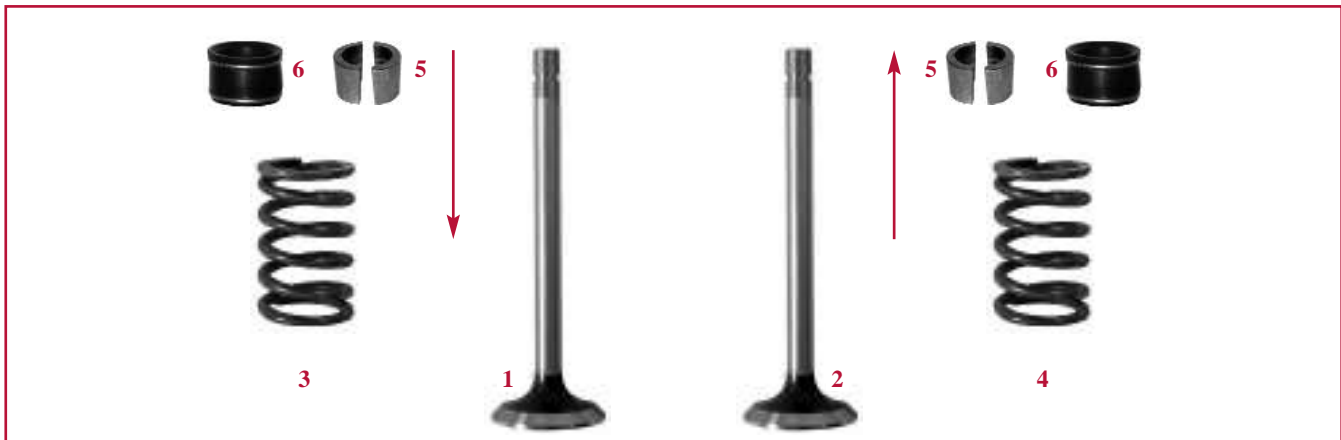
EINZELTEILE FÜR ZYLINDERKOPF
Motoren Ford

1	2	3	4	5	6	Motor	Schleppertyp
Einlassventil	Auslassventil	Feder	Feder	Klemmkeile	Dichtung		
Motoren 6 Zyl.							
25/42-75 (82850530, 87802256, 87802260)	25/43-75 (87802147, 87802258)	25/45-75 (83999742)	25/45-75 (83999742)	25/46-75 (81876796, 87802301)	25/47-75 (87801992, 87840154)	675/TA	MXM120, MXM130, MXM135, MXM140, MXM150, MXM155, MXM165, MXM175, MXM180, MXM190

KIPPHEBEL

1	2	3	4	5	6	7	Schleppertyp
Einlass Kipphebel	Auslass Kipphebel	Kipphebelschraube	Ventilstößel	Buchse	Stößelstange	Nockenwelle	
		25/52-9 (87801302)		25/56-9 (87800499)			MXM120, MXM130, MXM140, MXM155, MXM175, MXM190
25/50-9 (83956710)	25/50-9 (81804316)		25/54-9 (83946434)		25/53-5 (81877890)	25/80-14 (87802140)	MXM135, MXM150, MXM165, MXM180

Wir vertreiben keine Originalteile.
Die Nummern dienen lediglich als Beschreibung.

"THE RELIABLE SERVICE"

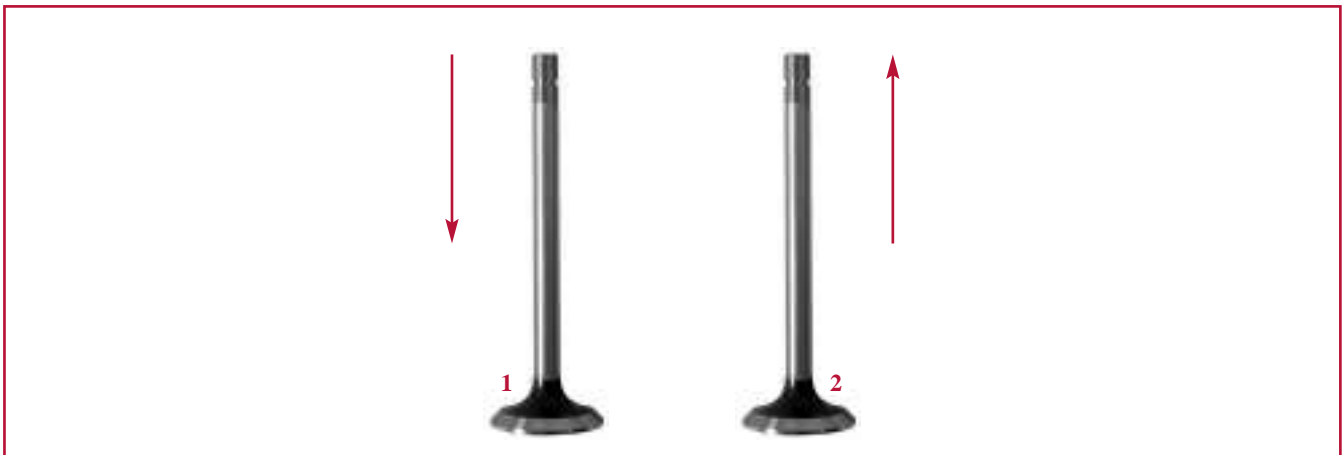
EINZELTEILE FÜR ZYLINDERKOPF
Motoren Same

1	2		
Einlassventil	Auslassventil	Motor	Schleppertyp
Motoren 3 Zyl			
25/42-87 (1966001C1, 1966435C1) Ø 44.5 mm - 30°	25/43-87 (1966393C1) Ø 39.5 mm - 45°	1000.3A	2120, 2130, 2120, 2130 PRO, PJ55, PJN55, PJV55
Motoren 4 Zyl.			
25/42-87 (1966001C1, 1966435C1) Ø 44.5 mm - 30°	25/43-87 (1966393C1) Ø 39.5 mm - 45°	1000.4A	2140, 2150, 2140, 2150 PRO, PJ65, PJN65, PJV65, PJ75, PJN75, PJV75

Ø = Ventiltellergrösse



DICHTSÄTZE FÜR MOTOR

Motoren IH - Alte Serie

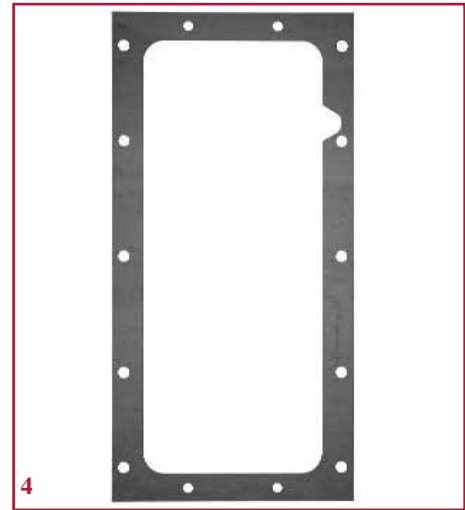
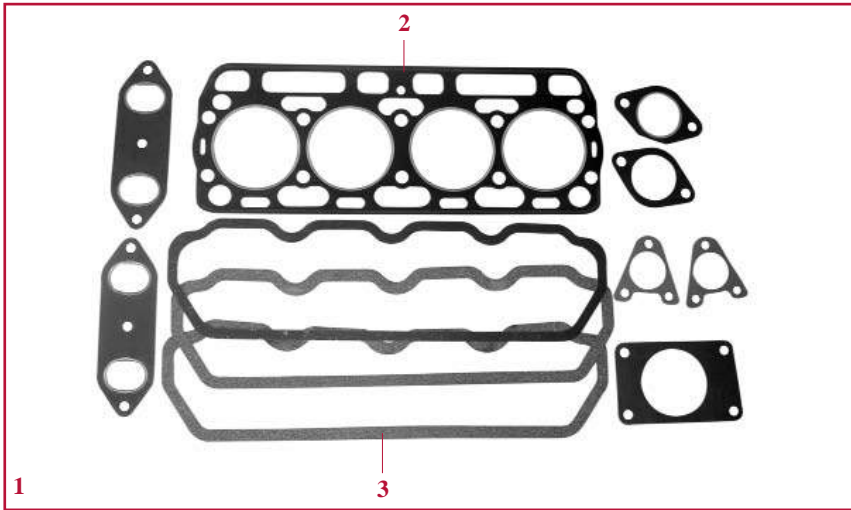

1	2	3	4	Motor	Schleppertyp
Kopfdichtsatz (incl. Kopfdichtung)	Kopfdichtung	Ventildeckeldichtung	Ölwannendichtung		
Motoren 2 Zyl.					
25/71-100 (3051138R92)	25/73-125 (713211R3)	25/74-125 (716884R2)	25/75-125 (715363R1)	D66	D212, D214, D215
25/71-101 (3051140R92)	25/73-128 (714885R2)			D74	D217, D219
Motoren 3 Zyl.					
25/71-102 (3051142R92)	25/73-126 (713212R3)	25/74-94 (716885R2)	25/75-94 (714863R1)	D99	D320, D322
25/71-94 (3051144R92)	25/73-94 (714886R2)			D111	D323, D324, D326
Motoren 4 Zyl.					
25/71-103 (3051146R92)	25/73-127 (717530R1)	25/74-95 (716455R2)	25/75-95 (714864R1)	D132	DGD-4, D430, D432, D440
25/71-95 (3051148R92)	25/73-95 (718864R1)			D148	D436, D438, D439

Wir vertreiben keine Originalteile.
 Die Nummern dienen lediglich als Beschreibung.



"THE RELIABLE SERVICE"



DICHTSÄTZE FÜR MOTOR

Motoren IH

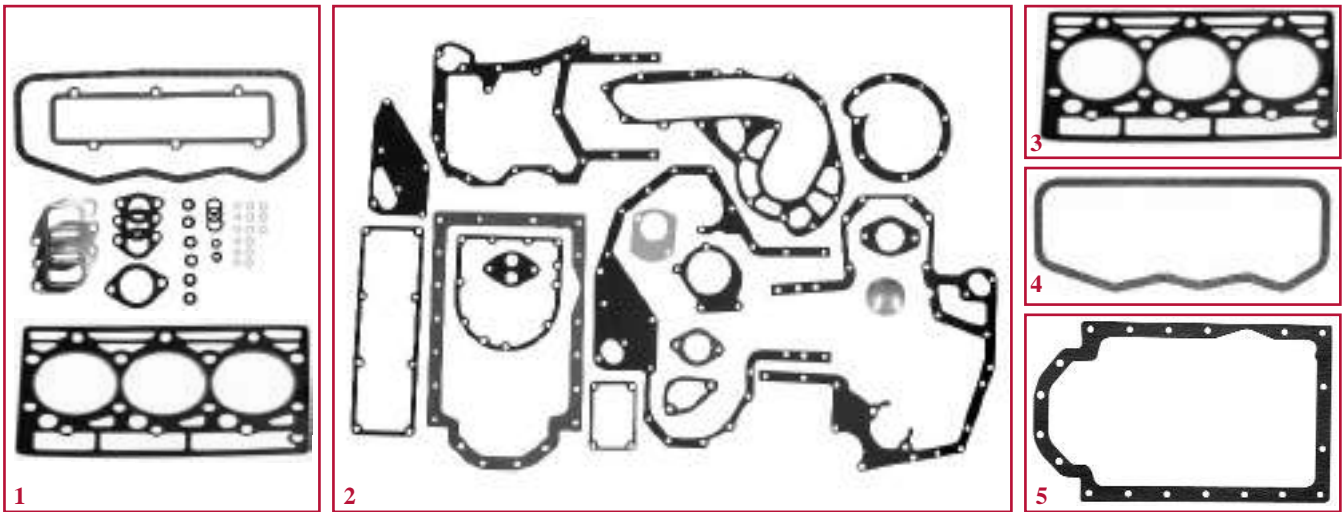

1	2	3	4	5	Motor	Schleppertyp
Kopfdichtsatz (incl. Kopfdichtung)	Blockdichtsatz	Kopfdichtung	Ventildeckeldichtung	Ölwannendichtung		
Motoren 3 Zyl.						
25/71-48 (3136798R99)	25/72-48 (3136802R99)	25/73-48 (3228361R2)	25/74-27 (3138641R1)	25/75-48 (3055160R3)	D155	353, 383, 385, 395, 423, 433, 440, 453, 533, 540, 3210
					D179	248, 454, 464, 484, 485, 495, 523, 553, 633, 640, 2400, 3220
Motoren 4 Zyl.						
25/71-33 (A) (706105R93)	25/72-33 (A) (B1036)	25/73-33 (703883R7)	25/74-25 (3069767R1)		BD144	B275, 276, 354
					BD154	238, 374, 384, B414, 424, 434, 444
25/71-49 (1967014C1, 3136799R99)	25/72-49 (1967011C1)	25/73-49 (3228362R2)	25/74-28 (3138642R2)		D206	474, 584, 585, 595, 624, 644, 645, 654, 733, 740, 3230 +XL
					D239	574, 674, 684, 685, 695, 724, 743, 744, 745, 833, 840, 940, 4210 +XL
					D246	278, 784, 785, 795, 824, 844, 4220 +XL
					D268	844S, 845, 884, 885, 895, 995, 4230, 4240 +XL
				25/75-49 (3055161R3)	DT239	856XL
Motoren 6 Zyl.						
25/71-50 (3136801R99)	25/72-50 (3136817R99, 1967013C1)	25/73-50 (3228019R2)	25/74-29 (3138688R2)	25/75-50 (3055987R93)	D310	946, 955
					D358	956, 1046, 1055, 1056
					DT358	1246, 1255
					DT402	1455

(A) Dichtsatz komplett : **25/70-33** - 3041249R92 (**25/71-33** + **25/72-33**)

Wir vertreiben keine Originalteile.
Die Nummern dienen lediglich als Beschreibung.



"THE RELIABLE SERVICE"

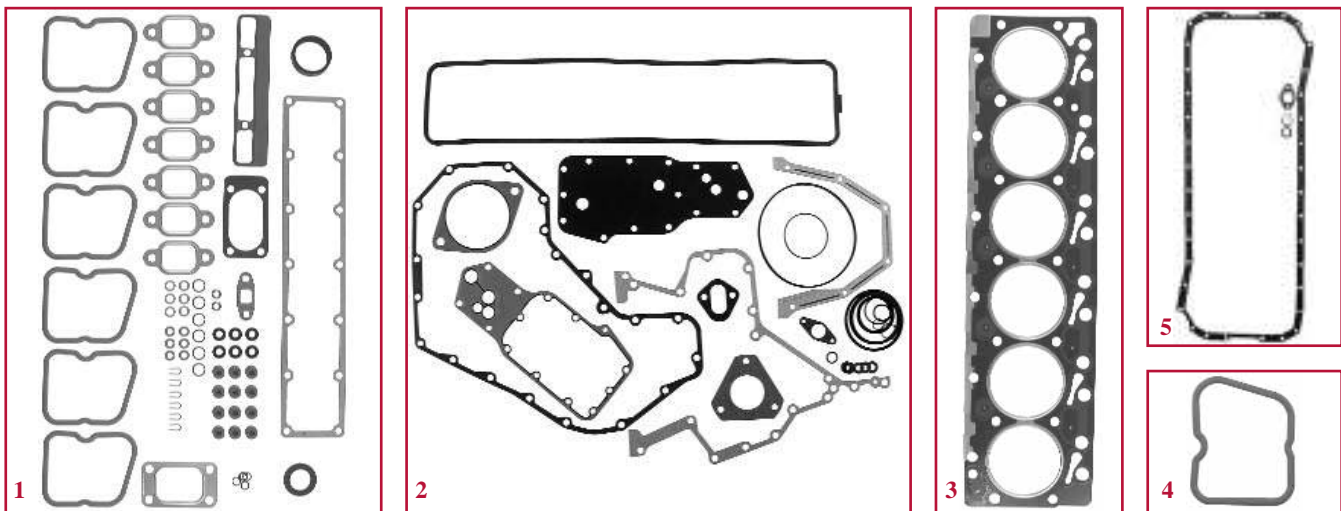

DICHTSÄTZE FÜR MOTOR
Motoren Cummins

1	2	3	4	5	Motor	Schleppertyp
Kopfdichtsatz	Blockdichtsatz	Kopfdichtung	Ventildeckeldichtung	Ölwannendichtung		
Motoren 4 Zyl.						
25/76-118 (A) (A77858, A77672, A77975)	25/72-118 (B) (A77860, A77671)	25/73-118 (J283333, A77754)	25/74-118 (J930906, J902666, J929795)	25/75-118 (A77673) Satz	4T390	5120, 5220
Motoren 6 Zyl.						
25/76-119 (A) (A77793, A77925, A77493, A77675, A77859)	25/72-119 (B) (A77861, A77491, A77674)	25/73-119 (J283335, J907057, J917358, A77755, J921394)	25/74-118 (J930906, J902666, J929795)	25/75-119 (A77676) Satz	6-590	5130, 5230
	25/72-120 (B) (A77868)				6T590	5140, 5150, 5240, 5250
25/76-144 (A) (A77794, A77678, A77630, A77592)	25/72-144 (B) (A77855, A77857, A77839)	25/73-144 (J928168, J938267, J931019, J921850, J911342, J907682, J935585)	25/74-144 (J905449, 00180434)	25/75-144 (A77679) Satz	6T830	7110, 7120, 7130, 7140, 7150
					6T830	7210, 7220, 7230, 7240, 7250 ⇒ JJA0064977 9310, 9330 ⇒ JEE0036500
25/76-145 (A) (A77842, A78042)					6T830	7210, 7220, 7230, 7240, 7250 JJA0064978 ⇒ 9310, 9330 JEE0036501 ⇒
25/76-144 (A) (A77794, A77678, A77630, A77592)					6T830	8910, 8920, 8930, 8940, 8950
25/76-145 (A) (A77842, A78042)	25/72-144 (B) (A77855, A77857, A77839)				6T830	9110, 9210, 9230, 9240
						MX180, MX200, MX210, MX220, MX230, MX240, MX255

(A) Ohne Kopfdichtung
 (B) Ohne Ölwannendichtung

Wir vertreiben keine Originalteile.
 Die Nummern dienen lediglich als Beschreibung.



"THE RELIABLE SERVICE"



DICHTSÄTZE FÜR MOTOR

Motoren Cummins

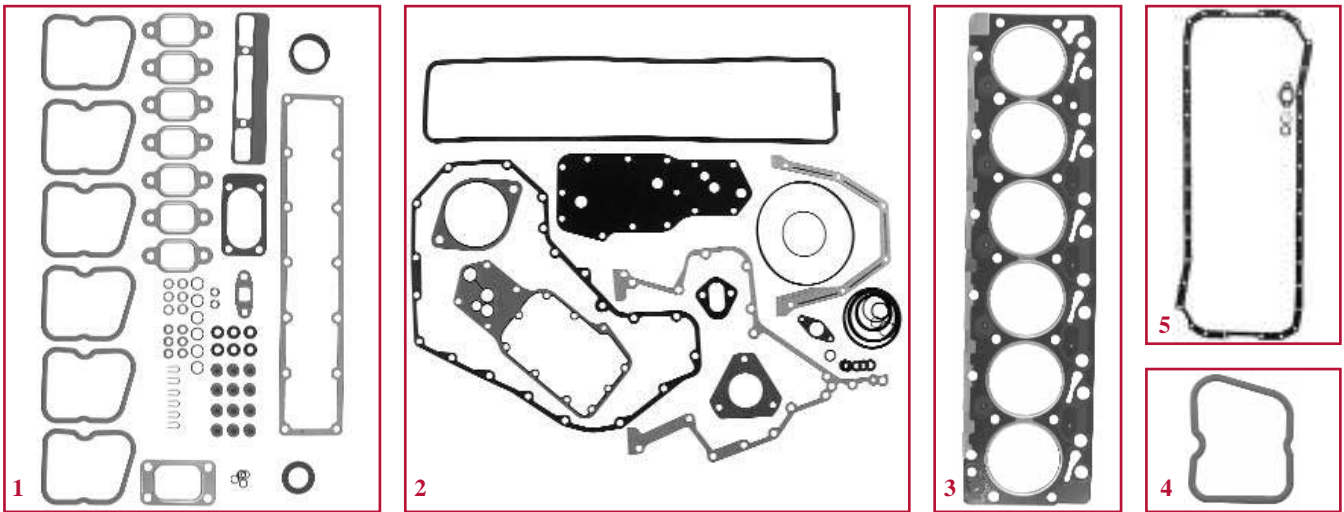

1	2	3	4	5		
Kopfdichtsatz	Dichtsatz (Unten)	Kopfdichtung	Ventildeckeldichtung	Ölwannendichtung	Motor	Schleppertyp
Mähdrescher						
25/76-119 (A) (A77793, A77925, A77493, A77675, A77859)	25/72-119 (B) (A77861, A77491, A77674)	25/73-119 (J283335, J907057, J917358, A77755, J921394)	25/74-118 (J930906, J902666, J929795)	25/75-119 (A77676) Satz	6T590	1640, 1644
	25/72-120 (B) (A77868)				6T590	2144, 2344
25/76-144 (A) (A77794, A77678, A77630, A77592)	25/72-144 (B) (A77855, A77857, A77839)	25/73-144 (J928168, J938267, J931019, J921850, J911342, J907682, J935585)	25/74-144 (J905449, 00180434)	25/75-144 (A77679) Satz	6T830	1660, 1666, 1670, 1680, 1688
					6T830	2166, 2188, 2365, 2366

(A) Ohne Kopfdichtung
(B) Ohne Ölwannendichtung

Wir vertreiben keine Originalteile.
Die Nummern dienen lediglich als Beschreibung.



"THE RELIABLE SERVICE"

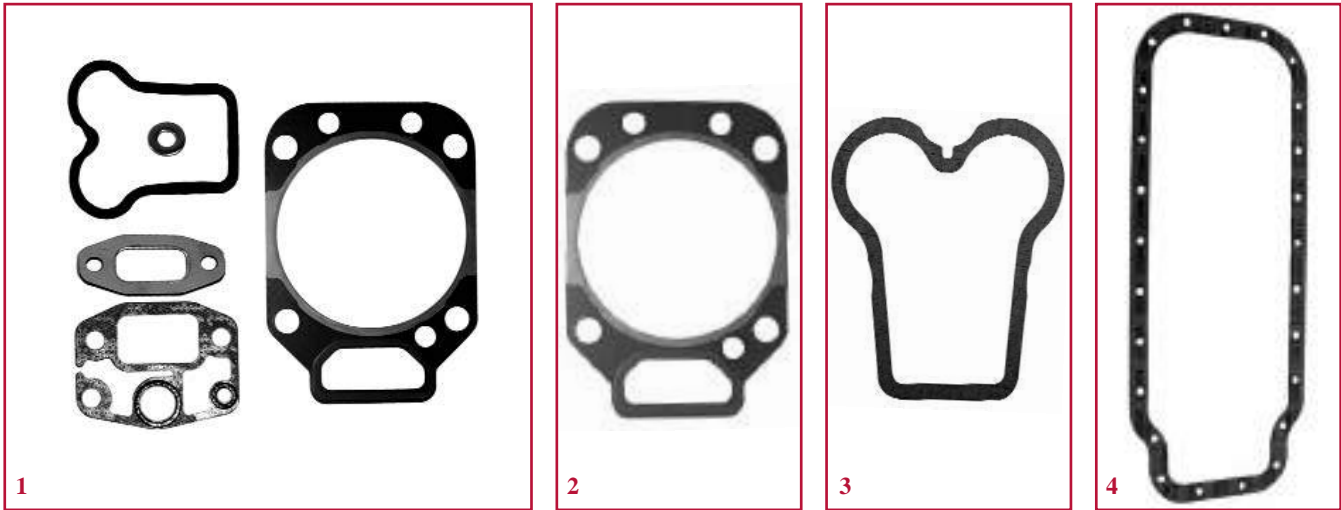

DICHTSÄTZE FÜR MOTOR
Motoren MWM

1	2	3	4	Motor	Schleppertyp
Kopfdichtsatz (incl. Kopfdichtung)	Kopfdichtung	Ventildeckeldichtung	Ölwannendichtung		
Motoren 3 Zyl.					
25/71-129 (B) (130100010746, 140100010713)	25/73-129 (C) (130142040702, 299508A1)	25/74-129 (C) (130100040705, 130100040727)	25/75-129	D 226-B 3	C55, C55A
				TD 226-B 3	C64, C64A, C70A CS68, CS75 (⇒ 12/98)
Motoren 4 Zyl.					
25/71-129 (B) (130100010746, 140100010713)	25/73-129 (C) (130142040702, 299508A1)	25/74-129 (C) (130100040705, 130100040727)	25/75-130 (140180150701, 140181150701)	TD 226-B 4	CS78, CS86, CS94 (⇒ 12/98)

(B) Für 1 Zylinder (ohne Buchsendichtungen)

(C) Für 1 Zylinder

DICHTSÄTZE FÜR MOTOR

Motoren Sisu

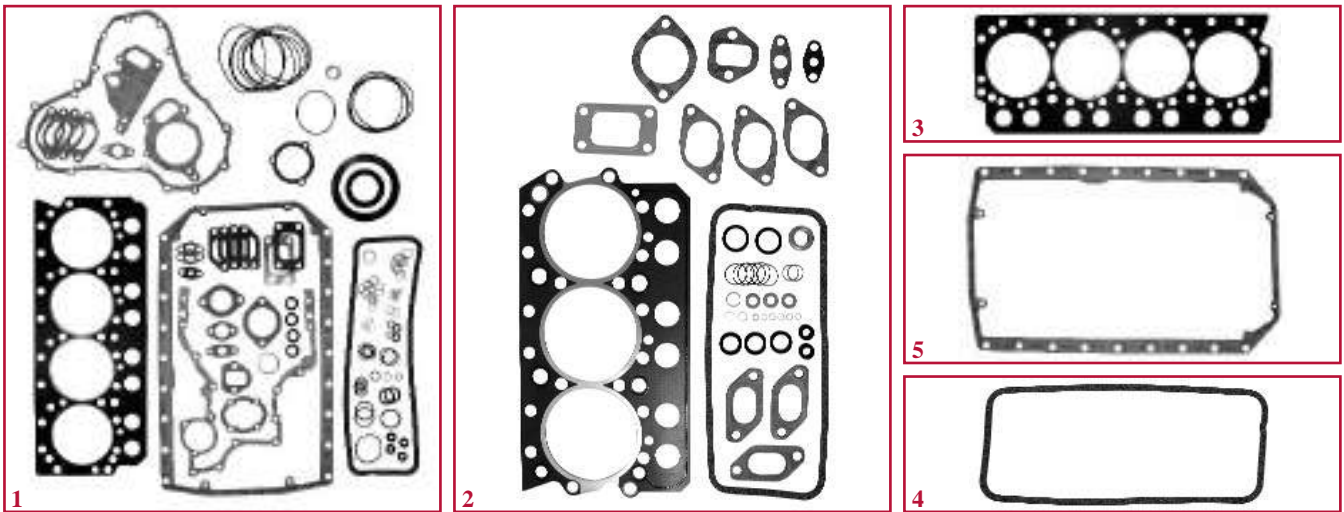

1	2	3	4	5		
Dichtsatz komplett	Kopfdichtsatz (incl. Kopfdichtung)	Kopfdichtung	Ventildeckeldichtung	Ölwannendichtung	Motor	Schleppertyp
Motoren 3 Zyl.						
25/70-137 (354099A1)	25/71-137 (132000010722)	25/73-137 (299647A1, 162084040701, 162000040751)	25/74-137 (162000040700)	25/75-137 (354103A1)	320D	CS68, CS75 (01/99 ⇒)
Motoren 4 Zyl.						
25/70-138 (142080010711)	25/71-138 (142080040703)	25/73-138 (142000040702, 142000040706, 132000040705)	25/74-138 (142000040701, 142000040705)	25/75-138 (162000150713)	420D	CS78, CS86, CS94 (01/99 ⇒) CS100, CS110
Motoren 6 Zyl.						
25/70-139 (162084010704, 162000010706)	25/71-139 (162084010705, 162000040703)	25/73-137 x 2 (299647A1, 162084040701, 162000040751)	25/74-137 x 2 (162000040700)	25/75-139 (162000150700)	620D	CS120, CS130, CS150, CVX120, CVX130, CVX150, CVX170, CVX1135, CVX1145, CVX1155, CVX1170, CVX1190

Wir vertreiben keine Originalteile.
Die Nummern dienen lediglich als Beschreibung.



"THE RELIABLE SERVICE"



DICHTSÄTZE FÜR MOTOR

Motoren Perkins

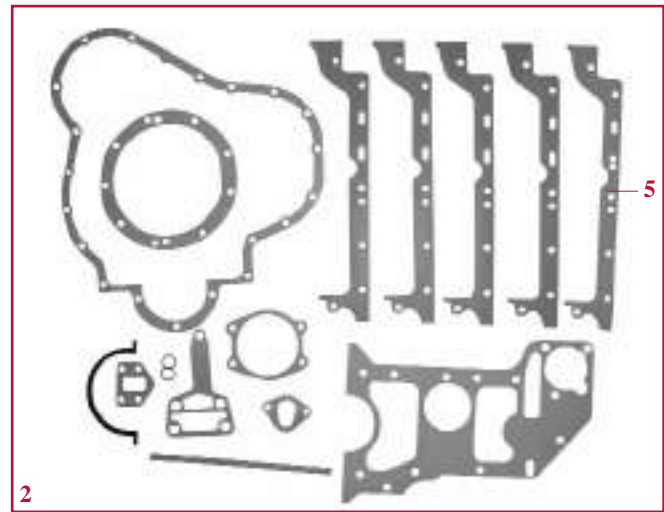
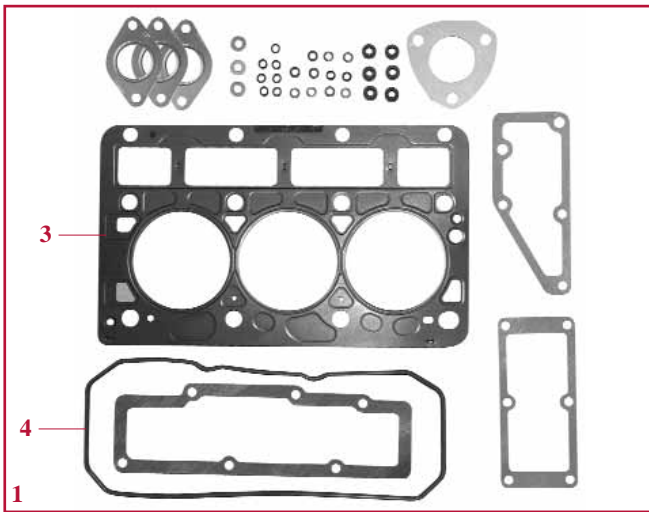

1	2	3	4	5	Motor	Schleppertyp
Kopfdichtsatz (incl. Kopfdichtung)	Blockdichtsatz	Kopfdichtung	Ventildeckeldichtung	Ölwannendichtung		
Motoren 3 Zyl.						
25/71-136 (130300010751, 130300010763)	25/72-136 (13030010752, 130300010765, 299582A1)	25/73-136 (296217A1, 130300040713)	25/74-136 (296216A1, 130300040719)	25/75-136 (296241A1, 404299A1, 130300150702)	903.27	C50, CS48, CS52, CX50
					903.27T	C60, CS58, CS63, CX60
Motoren 4 Zyl.						
25/71-47 (3118124R1)	25/72-47 (3118123R91)	25/73-47 (3118173R1)	25/74-26 (3118186R1)	25/75-135 (291981A1, 3118272R1)	A4.212	475
25/71-135 (311792A1, 315988A1)	25/72-135 (311793A1, 315989A1, 292009A1)	25/73-135 (365369A1, 311766A1, 315990A1)	25/74-135 (311043A1)		1004.4T	C70, C80, C90, CX70, CX80, CX90, CX100, MX80C, MX90C, MX100C

Wir vertreiben keine Originalteile.
 Die Nummern dienen lediglich als Beschreibung.



"THE RELIABLE SERVICE"



DICHTSÄTZE FÜR MOTOR

Motoren Iveco

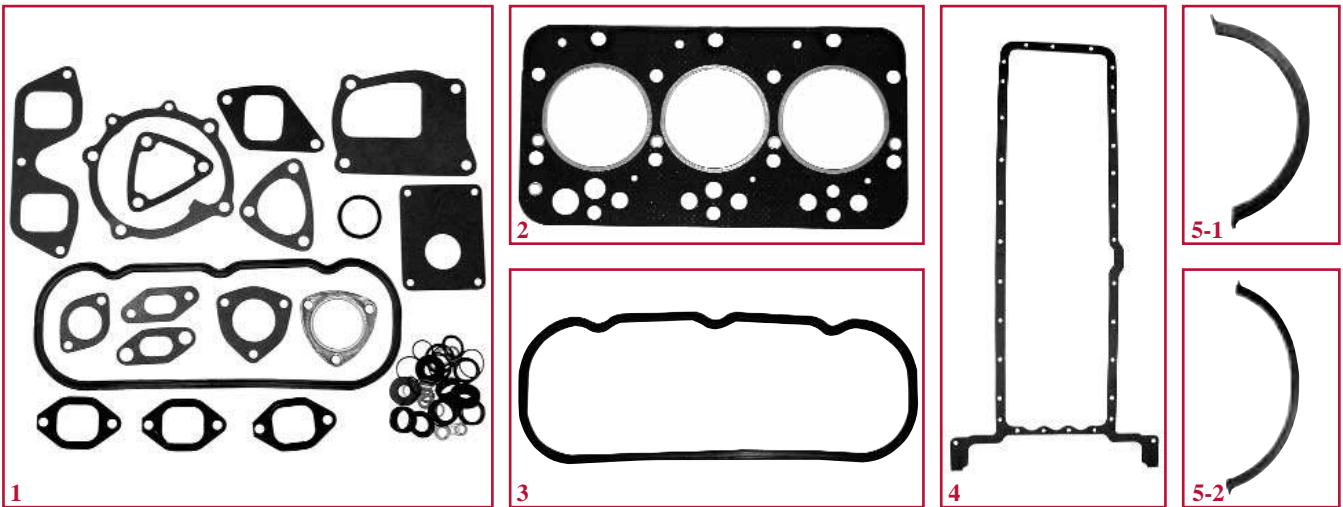

1	2	3	4	5	Motor	Schleppertyp
Kopfdichtsatz	Kopfdichtung	Ventildeckeldichtung	Ölwannendichtung	Kurbelwellen Dichtung		
Motoren 3 Zyl.						
25/76-131 (A)	25/73-131 (98472006)	25/74-131 (99460554)	25/75-131 (1940006)	25/11-131 (5-1) (4031577) Vorne	8035.06	AVJ55, JX55
	25/73-132 (98472011)			25/13-131 (5-2) (460753) Hinten	8035.05	AVJ60, JX60, JX65, JX70, JX1060C, JX1070C, JX1075C, VJ60
Motoren 4 Zyl.						
25/76-133 (A)	25/73-133 (98472008)	25/74-133 (500301351)	25/75-133 (1940004)	25/11-131 (5-1) (4031577) Vorne	8045.06	AVJ70, JX70U, JX75, VJ70
	25/73-134 (98456215)			25/13-131 (5-2) (4600753) Hinten	8045.05	JX80, JX80U, JX85, JX90, JX90U, JX95, JX100U, VJ80

(A) Ohne Kopfdichtung

Wir vertreiben keine Originalteile.
Die Nummern dienen lediglich als Beschreibung.



"THE RELIABLE SERVICE"



DICHTSÄTZE FÜR MOTOR

Motoren Ford

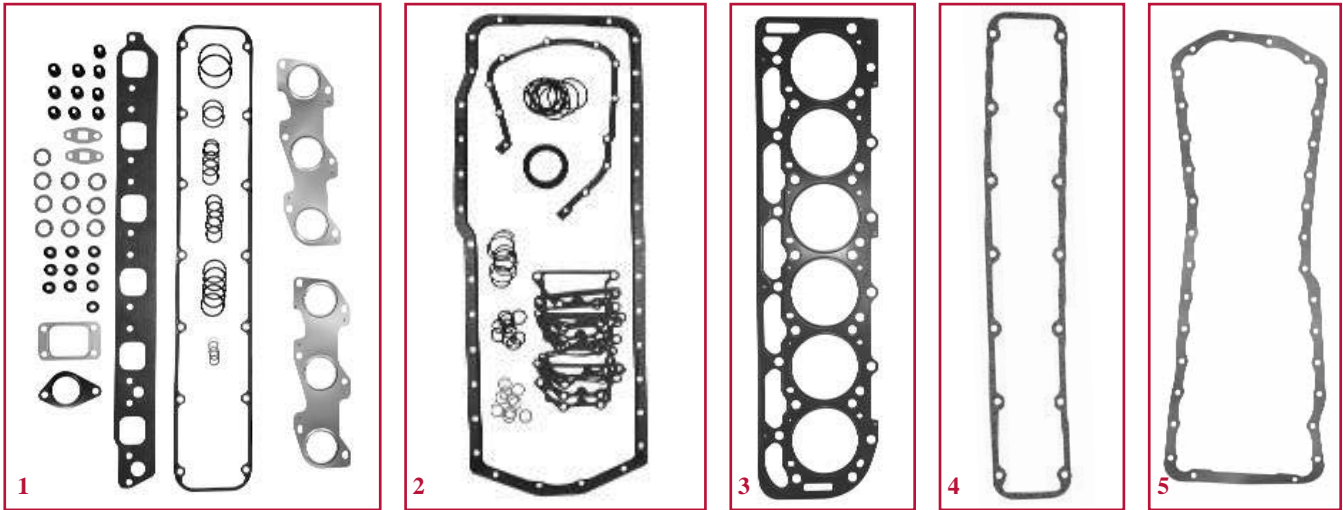

1	2	3	4	5	Motor	Schleppertyp
Kopfdichtsatz (incl. Kopfdichtung)	Blockdichtsatz	Kopfdichtung	Ventildeckeldichtung	Ölwannendichtung		
Motoren 6 Zyl.						
		25/73-140 (87801752)			675/TA	MXM120, MXM130
25/76-104 (1930959)	25/72-104 (1930960)	25/73-141 (87801753)	25/74-140 (83976376)	25/75-140 (87800945)	675/TA	MXM135, MXM150, MXM165, MXM180
					675/TA	MXM140, MXM155, MXM175, MXM190

Wir vertreiben keine Originalteile.
Die Nummern dienen lediglich als Beschreibung.



"THE RELIABLE SERVICE"



DICHTSÄTZE FÜR MOTOR

Motoren Same

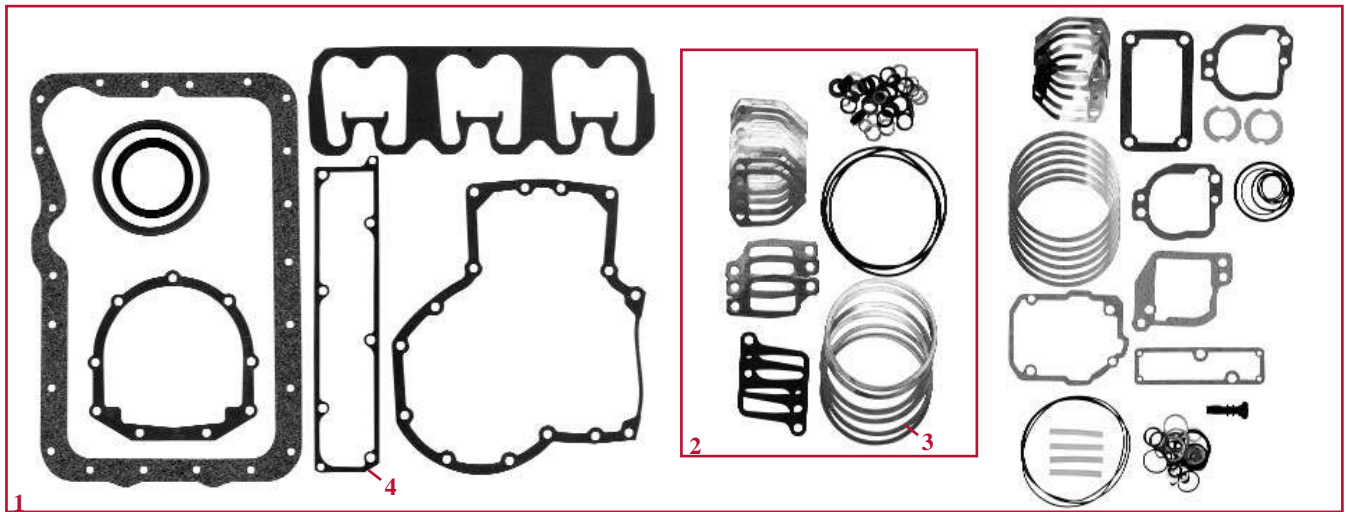

1	2	3	4	Motor	Schleppertyp
Dichtsatz komplett	Kopfdichtsatz	Kopfdichtung	Ventildeckeldichtung		
Motoren 3 Zyl.					
25/70-142 (A)	25/71-142 (C)	25/73-142 A (D) (1966442C1) 0.5 mm 25/73-142 B (D) (1966443C1) 0.7 mm 25/73-142 C (D) (1530319C1) 0.8 mm 25/73-142 D (D) (1966444C1) 1.0 mm	25/74-145	1000.3A	2120, 2130, 2120 PRO, 2130 PRO, PJ55, PJN55, PJV55
Motoren 4 Zyl.					
25/70-143 (B)	25/71-142 (C)	25/73-142 A (D) (1966442C1) 0.5 mm 25/73-142 B (D) (1966443C1) 0.7 mm 25/73-142 C (D) (1530319C1) 0.8 mm 25/73-142 D (D) (1966444C1) 1.0 mm	25/74-146	1000.4A	2140, 2150, 2140 PRO, 2150 PRO, PJ65, PJN65, PJV65, PJ75, PJN75, PJV75

- (A) Für 3 Zylinder (incl. Zylinderkopfdichtung in 4 Stärken)
- (B) Für 4 Zylinder (incl. Zylinderkopfdichtung in 4 Stärken)
- (C) Für 1 Zylinder (incl. Zylinderkopfdichtung in 4 Stärken)
- (D) Für 1 Zylinder





Wir vertreiben keine Originalteile.
Die Nummern dienen lediglich als Beschreibung.



"THE RELIABLE SERVICE"



LOCTITE®

Bestell-Nr.	Beschreibung	Abb.
Gewindebefestigung		
78/9604-101 50 ml	Loctite® 243 Geeignet für alle Gewindeverbindungen aus Metall. Verhindert Losdrehen durch Vibration z.B. an Getrieben, Motoren etc. geringfügig öltolerant. Die Verbindungen sind mit normalem Werkzeug noch demontierbar. Toleriert geringe öltartige Verschmutzungen. Sichert Schrauben, Muttern, Stehbolzen gegen das Losdrehen durch Vibration z.B. an Motoren, Getrieben & Gehäusen.	
78/9604-103 10 ml		
78/9604-102 50 ml	Loctite® 271 Geeignet für alle Gewindeverbindungen aus Metall, inklusive passive Materialien, wie z.B. hochlegiertes Stahl. Ideal für stark vibrations- & schlagbeanspruchte Gewindeverbindungen, z.B. Stehbolzen an Motoren oder Pumpen etc. Alle Schraubverbindungen, wo Beständigkeit gegen starke Stoßbeanspruchungen & Vibrationen bzw. extreme Umwelt- oder chemische Einflüsse gefordert wird.	
Hydraulik - Dichtungsmittel		
78/9604-121 50 ml	Loctite® 542 Gewindedichtung für hochbelastete Feingewindeverbindungen aus Metall an Hydraulik- & Pneumatikanlagen. Für Anwendungen im Maschinenbau, der Automobilindustrie & an Land und Baumaschinen.	
Bloppresse		
78/9604-110 50 ml	Loctite® 603 Dies Produkt ist ein öltolerantes Fügeprodukt mit großem Anwendungsspektrum. Schnellhärtend, mit hoher Festigkeit. Toleriert geringe öltartige Verschmutzungen. Geeignet zur Befestigung zylindrischer Metallteile mit geringen Spaltmaßen (bis 0,1 mm Spalt). Besonders geeignet zur Lagerbefestigung.	
78/9604-113 50 ml	Loctite® 648 Universelles Fügeprodukt mit einer Temperaturbeständigkeit bis 175°C. Spaltfüllvermögen bis 0,15 mm. Handfestigkeit bereits nach 5 Minuten. Zur Verklebung von Buchsen, Lagern & anderen zylindrischen Metallteilen.	

Wir vertreiben keine Originalteile.
Die Nummern dienen lediglich als Beschreibung.



"THE RELIABLE SERVICE"

LOCTITE®

Bestell-Nr.	Beschreibung	Abb.
Flächendichtung		
78/9604-130 50 ml	Loctite® 510 Anaerobe, einkomponentige Flächendichtung zum Abdichten von formstabilen Metallflächen. Hochfest - mit einer Temperaturbeständigkeit bis max.200°C. Dichtspalt bis 0,25 mm. Aushärtung unter Sauerstoffabschluß & Metallkontakt der Paßteile. Diese Dichtung ist thixotrop & kann auf vertikale Flächen aufgetragen werden, ohne zu tropfen oder zu verlaufen. Empfohlen zum Dichten steifer Flansche in Pumpen, Kupplungen, Getrieben & Motorblöcken. Zum Abdichten von formstabilen Metallteilen wie z.B. Motor und Getriebegehäuse. Kein Spalt für die Dichtungsstärke notwendig (Nullspalt).	
78/9604-143 50 ml	Loctite® 5926 Dauerelastische Silikondichtung zum Abdichten von Flächen jeder Form & Größe in kürzester Zeit. Ideal für sehr viele Anwendungen im Kfz Bereich. Einfach aufzutragen - eine perfekte Dichtung in Minuten. Für Deckel & Flansche an Motoren, Ölwanne, Wasserpumpen, Hydraulikgeräten, Diesel- & Benzinmotoren, landwirtschaftlichen Geräten.	
78/9604-139 300 ml	Loctite® 5699 Geeignet für alle Arten von Flächen, inklusive Blechen. Hervorragende Wasser-Glykolbeständigkeit. Keine Korrosionswirkung sowie geruchsarm.	
78/9604-140 300 ml	Loctite® 5910 Zur Abdichtung von nicht verwindungssteifen Flanschen, bei denen eine hohe Vibrations- & Ölbeständigkeit gefordert ist. z.B. Aluminium Ölwanne, Steuergehäusedeckel.	
Sofortkleber		
78/9604-150 20 gr.	Loctite® 401 Universal-Sofortklebstoff. Klebt nahezu alle Materialien wie Kunststoffe, Elastomere, Metalle, Papier, Karton, Holz. Kleben einer PVC-Dichtung auf ein ABS-Gehäuse bei der Produktion von KFZ-Spiegeln. Kleben von Moosgummi auf ein Stahl- oder Kunststoffgehäuse. Kleben von PVC-Folien auf Papier bei der Herstellung von Verpackungsmaterial. Kleben von kleinen Kunststoffteilen auf Holz, beispielsweise in der Möbelindustrie.	
Reinigung		
78/9604-221 3 Ltr.	Loctite® 7850 Natürlicher Handreiniger aus Zitruschalenextrakten, mineralölfrei, mit den wichtigen Hautpflegesubstanzen Jojobaöl, Lanolin & Aloe. Handreiniger für stark verschmutzte Hände wie z.B. nach Autoreparaturen. Der Zusatz von gemahlenem Bimsstein erhöht die Tiefenwirkung & entfernt den Schmutz ohne aggressive Lösungsmittel. Entfernt festsitzenden Schmutz, Fett & Öl.	

Wir vertreiben keine Originalteile.
 Die Nummern dienen lediglich als Beschreibung.

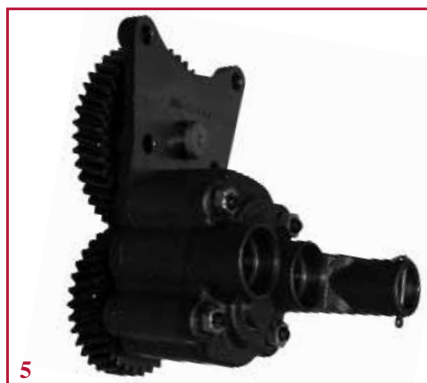
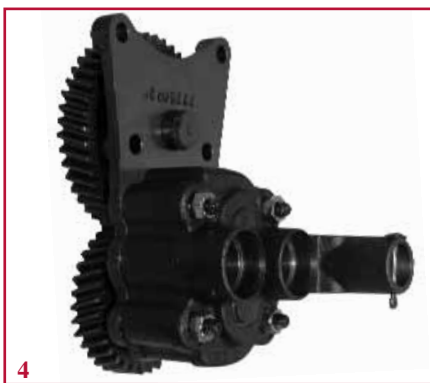
"THE RELIABLE SERVICE"

MOTORÖLPUMPEN
Motoren IH

Bestell-Nr.	Abb.	Motor	Schleppertyp
Motoren 3 Zyl.			
25/90-35 (3055193R95, 3132832R92, 3136429R95)	1	D155	353, 383, 385, 395, 423, 433, 440, 453, 533, 540, 3210
		D179	248, 454, 464, 484, 485, 495, 523, 553, 633, 640, 2400, 3220
Motoren 4 Zyl.			
25/90-86 (3064060R91)	2	BD154	238, 374, 384, 424, 434, 444, B414
		BD144	276, 354, 364
25/90-36 (3136430R95)	3	D206	584, 585, 595, 624, 644, 654, 733, 740, 3230 +XL
		D239	684, 685, 695, 724, 743, 744, 745, 833, 840, 940, 4210 +XL
		D246	278, 784, 785, 795, 824, 844, 4220 +XL
		D268	844S, 845, 884, 885, 895, 995, 4230, 4240 +XL
25/90-37 (3136431R95, 3136306R91)	4	D206	474
		D239	574, 674
25/90-38 (3136432R95, 3055195R91)	5	DT239	856 +XL
Motoren 6 Zyl.			
25/90-39 (3136433R95, 3136445R92, 3055195R93)	6	D310	946, 955
		D358	956, 1046, 1055, 1056
25/90-38 (3136432R95, 3055195R91)	5	DT358	1246, 1255
		DT402	1455

Wir vertreiben keine Originalteile.
 Die Nummern dienen lediglich als Beschreibung.

"THE RELIABLE SERVICE"

MOTORÖLPUMPEN
Motoren Cummins

1

2

3

Bestell-Nr.	Abb.	Motor	Schleppertyp
Motoren 4 Zyl.			
25/90-43 (J930336, J937027, J926202, J924719, J918211, J914005, J906413)	1	4T390	5120, 5220
Motoren 6 Zyl.			
25/90-40 (J930337, J937404, J941742, J926203, J924720, J918212, J914006, J906414, J901175)	2	6-590	5130, 5230
		6T590	1896, 2096, 5140, 5150, 5240, 5250, MX100, MX110, MX120, MX135, MX150, MX170
25/90-41 (J924644, J926201, J930338, J948071, J918213, J921067, J906415, J910066)	3	6T830	7110, 7120, 7130, 7140, 7210, 7220, 7230, 7240, 7250, 8910, 8920, 8930, 8940, 8950, 9110, 9130, 9220, 9230, 9240, 9310, 9330, MX180, MX200, MX220, MX240, MX270
Mährescher			
25/90-40 (J930337, J937404, J941742, J926203, J924720, J918212, J914006, J906414, J901175)	2	6T590	1620, 1640, 1644
		6T830	1666, 1670, 1688, 2166, 2188, 2365, 2366, 2388, CF60, CF70, CF80

Motoren MWM

Bestell-Nr.	Motor	Schleppertyp	Abb.
Motoren 3 Zyl.			
25/90-72 (130100070708) Ansauganschluss Ø 29 mm	D 226-B 3	C55, C55A	
	TD 226-B 3	C64, C64A, C70A CS68, CS75 (⇒ 12/98)	
Motoren 4 Zyl.			
25/90-73 (130100070715) Ansauganschluss Ø 36 mm	TD 226-B 4	CS78, CS86, CS94 (⇒ 12/98)	

Wir vertreiben keine Originalteile.
Die Nummern dienen lediglich als Beschreibung.

"THE RELIABLE SERVICE"

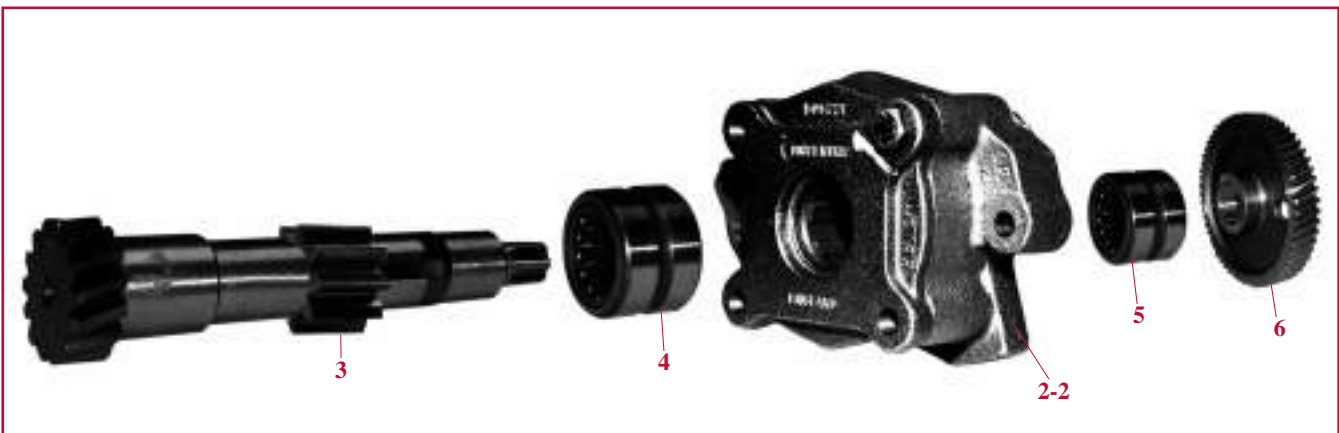
MOTORÖLPUMPEN & BALANCER
Motoren Perkins

1	2	3	4	5	6	Motor	Schleppertyp
Balancer	Ölpumpe	Hauptwelle	Wellendichtring vorne	Wellendichtring hinten	Zahnrad		
Motoren 3 Zyl.							
	25/90-71 (2-1) (296240A1, 41314187, 130300070706)					903.27	C50, CS48, CS52, CX50
						903.27T	C60, CS58, CS63, CX60
Motoren 4 Zyl.							
25/90-68 (293171A1, 390910A1, 4111K053)	25/90-70 (2-2) (293177A1, 4132F021, 4132F041)	25/93-68 (293039A1)	25/93-68 (293039A1)	25/89-69 (293024A1)	25/94-68 (293029A1)	1004.4T	C80, C90, CX80, CX90, CX100, MX80C, MX90C, MX100C
25/90-69 (3935598A1, 4111K051, 4111K022, 313626A1)						1004.4T	C70, CX70

Wir vertreiben keine Originalteile.
 Die Nummern dienen lediglich als Beschreibung.



"THE RELIABLE SERVICE"



MOTORÖLPUMPEN
Motoren Iveco

Bestell-Nr.	Abb.	Motor	Schleppertyp
Motoren 3 Zyl.			
25/90-66 (4705827)	1	8035.06	AVJ55, JX55
		8035.05	AVJ60, JX60, JX65, JX1060C, VJ60
Motoren 4 Zyl.			
25/90-66 (4705827)	1	8045.06	AVJ70, JX70U, JX75, VJ70
		8045.05	JX80, JX80U, VJ80 JX85 (⇒ 13286)
25/90-81 (98415162)	2		





Motoren Ford

Bestell-Nr.	Motor	Schleppertyp	Abb.
Motoren 6 Zyl.			
25/90-67 (87802585, 81868538)	675/TA	MXM120, MXM130, MXM135, MXM140, MXM150, MXM155, MXM165, MXM175, MXM180, MXM190	

Wir vertreiben keine Originalteile.
 Die Nummern dienen lediglich als Beschreibung.

"THE RELIABLE SERVICE"

ÖLEINFÜLLDECKEL & ÖLABLASSSCHRAUBE

Bestell-Nr.	Beschreibung	Schleppertyp	Abb.
25/85-17 (3118164R1)	Öleinfülldeckel	475	
25/85-18 (4232606)		JX55, JX60, JX65, JX70, JX70U, JX75, JX80, JX80U, JX85, JX90, JX90U, JX95, JX100U, JX1060C, JX1060V, JX1070C, JX1070N, JX1070V, JX1075C, JX1075N, JX1075V	
25/85-16 (87761857)		MXM120, MXM130, MXM135, MXM140, MXM150, MXM155, MXM165, MXM175, MXM180, MXM190	
25/88-12 (218386A1)	Ölablass-Schraube	C50, C60, C70, C80, C90, CS48, CS52, CS58, CS63, CX100, CX50, CX60, CX70, CX80, CX90, MX80C, MX90C, MX100C	
25/88-13 (81822147)		MXM120, MXM130, MXM135, MXM140, MXM150, MXM155, MXM165, MXM175, MXM180, MXM190	

ÖLPEILSTAB

Bestell-Nr.	Schleppertyp	OEM	Abb.
25/86-18	433, 440, 533, 540, 633, 640	3218617R91	
25/86-19	644, 733, 743XL, 744, 745, 745XL, 833, 844, 844XL	3218623R92	
25/86-20	733, 740, 743XL, 745XL, 833, 840, 844XL, 845XL, 856XL, 940	1806958C2, 1806958C4	

Wir vertreiben keine Originalteile.
Die Nummern dienen lediglich als Beschreibung.



“THE RELIABLE SERVICE”

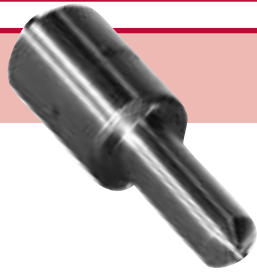
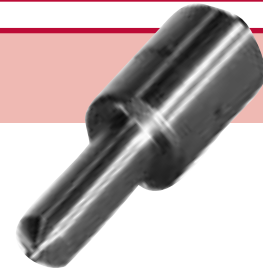

EINSPRITZDÜSEN

Motoren IH

Bestell-Nr.	Einspritzdüsen-Nr.	Schleppertyp	OEM
25/117-54	DNOSD1550 0434290014	D212, D214, D215, D217, D219, D320, D322, D324, D326, D430, D432, D436, D438, D439, D440	718383R2
25/117-51	BDN4SD6299 5643095 0434250056	238, B275, 276, 354, 374, 384, B414, 424, 434, 444 <i>Motoren BD144, BD154 motoren</i>	3040871R91
25/117-53	DLLA150S836 0433271838	238, 248, 258, 385, 395, 433, 440, 484, 485, 495, 533, 540, 584, 585, 595, 633, 640, 733, 740, 833, 955, 956, 1056, 3210, 3220, 3230	3218248R2
25/117-52	DLLA150S815 0433271849	248, 268, 278, 288, 385, 433, 484, 485, 684, 685, 695, 743, 744, 745, 785, 795, 833, 844, 844S, 845, 885, 895, 955, 956, 995, 1046, 1055, 1246, 1255, 4210, 4220, 4230, 4240	3218251R2
25/117-55	DLLA150S716 0433271282	248, 385, 484, 485, 946	
25/117-56	DLLA150S2641 0433270120	353, 383, 423, 433, 453, 474, 533, 644, 645, 654, 724, 946	3055426R91, 3055426R92
25/117-57	DLLA150S417 0433271180	454, 553, 574, 744, 844, 844S, 1046, 1246	3055428R92
25/117-65	DLLA150S690	454, 2400 <i>Ersetzt durch 25/117-52</i>	3218251R1
25/117-58	DLLA150S843 0433271834	1455	3218255R2

Motoren Cummins

Bestell-Nr.	Einspritzdüsen-Nr.	N° Bosch	OEM
25/117-131	DLLA155P135	0433171123	A77700, J908513
25/117-60	DLLA150P115	0433171104	
25/117-61	DLLA150P133	0433171121	
25/117-59	DLLA155P74 (9mm)	0433171074	J909476
25/117-187	6801118 (7mm) 6801121 FNG	-	J919322
25/117-291			3023556



**Mehrfache Zuordnung bei verschiedenen Modellen - Überprüfen Sie die Nummer auf der Düse.
Für weitere Zuordnungen nehmen Sie bitte Kontakt mit uns auf.**

Wir vertreiben keine Originalteile.
Die Nummern dienen lediglich als Beschreibung.

"THE RELIABLE SERVICE"

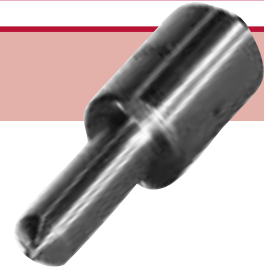
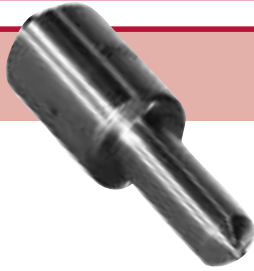
EINSPRITZDÜSEN

Motoren MWM

Bestell-Nr.	Einspritzdüsen-Nr.	Schleppertyp	OEM
25/117-188	DLLA152S1180 0433271691	C55, C55A CS94 (⇒ 12/98)	130142080703
25/117-189	DLLA151S972	C64, C64A, C70A CS68, CS75, CS78, CS86 (⇒ 12/98)	130182080701

Motoren Sisu

Bestell-Nr.	Einspritzdüsen-Nr.	Schleppertyp	OEM
25/117-190	33426	CS68, CS78 (01/99 ⇒)	142000080704
25/117-191	SDLLA152M34359	CS75, CS86, CS94 (01/99 ⇒) CVX120, CVX130, CVX150, CVX170	142000080703
25/117-192	SDLLA150S620	CS110, CS120, CS130, CS150 (⇒ DBD0015200)	162000080702
25/117-193	SDLLA145M34447	CS100, CS110, CS120, CS130, CS150 (DBD0075001 ⇒)	142000080709
25/117-194	SDLLA152M35926	CVX1135, CVX1145, CVX1155, CVX1170, CVX1190	162000080867

Motoren Perkins

Bestell-Nr.	Einspritzdüsen-Nr.	Schleppertyp	OEM
25/117-195	L072PBA	C70, CX70	313634A1
25/117-196	L060PBA	C80, C90, CX80, CX90, MX80C, MX90C	293758A1
25/117-197	L063PBA	CX100, MX100C	293187A1

Motoren Iveco

Bestell-Nr.	Einspritzdüsen-Nr.	Schleppertyp	OEM
25/117-198	DLLA132S1335	JX55, JX75 (⇒ 13286), JX70U	500317390
25/117-199	DLLA132S1384	JX55, JX75 (13287 ⇒), JX80, JX1060C	504051747
25/117-200	DLLA132S1320	JX60, JX65, JX70, JX80U, JX85, JX90, JX90U, JX95, JX100U, JX1070C, JX1075C	99469341



Mehrfache Zuordnung bei verschiedenen Modellen - Überprüfen Sie die Nummer auf der Düse.
Für weitere Zuordnungen nehmen Sie bitte Kontakt mit uns auf.

Wir vertreiben keine Originalteile.
Die Nummern dienen lediglich als Beschreibung.

"THE RELIABLE SERVICE"



EINSPRITZDÜSEN

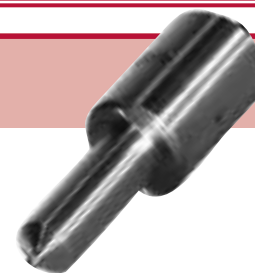

Motoren Ford

Bestell-Nr.	Einspritzdüsen-Nr.	Schleppertyp	OEM
25/117-201		MXM135, MXM150, MXM165, MXM180	9968197
25/117-209		MXM175, MXM190 (⇒ C4874)	87802537
25/117-210		MXM175, MXM190 (D4874 ⇒)	87803276

Motoren Same

Bestell-Nr.	Einspritzdüsen-Nr.	Schleppertyp	OEM
25/117-202	DLLA150S925 0433271804	2120, 2120 PRO, 2130, 2130 PRO, 2140, 2140 PRO, 2150, 2150 PRO	1966539C1
25/117-203		PJ55, PJN55, PJV55, PJ65, PJN65, PJV65, PJ75, PJN75, PJV75	440011A1

EINSPRITZDÜSENDICHTUNGEN

Bestell-Nr.	Beschreibung	OEM	Abb.
25/118-7	alle Modelle 17 x 19 x 3.4	717203R1	
25/118-9	Serien 23, 33, 44, 45, 56 24 x 18 x 1.5		
25/118-6	alle Modelle MXM 14 x 7 x 1.8	81873921	
25/119-7	alle Modelle MXM	81876874	



Mehrfache Zuordnung bei verschiedenen Modellen - Überprüfen Sie die Nummer auf der Düse.
Für weitere Zuordnungen nehmen Sie bitte Kontakt mit uns auf.

Wir vertreiben keine Originalteile.
Die Nummern dienen lediglich als Beschreibung.



"THE RELIABLE SERVICE"

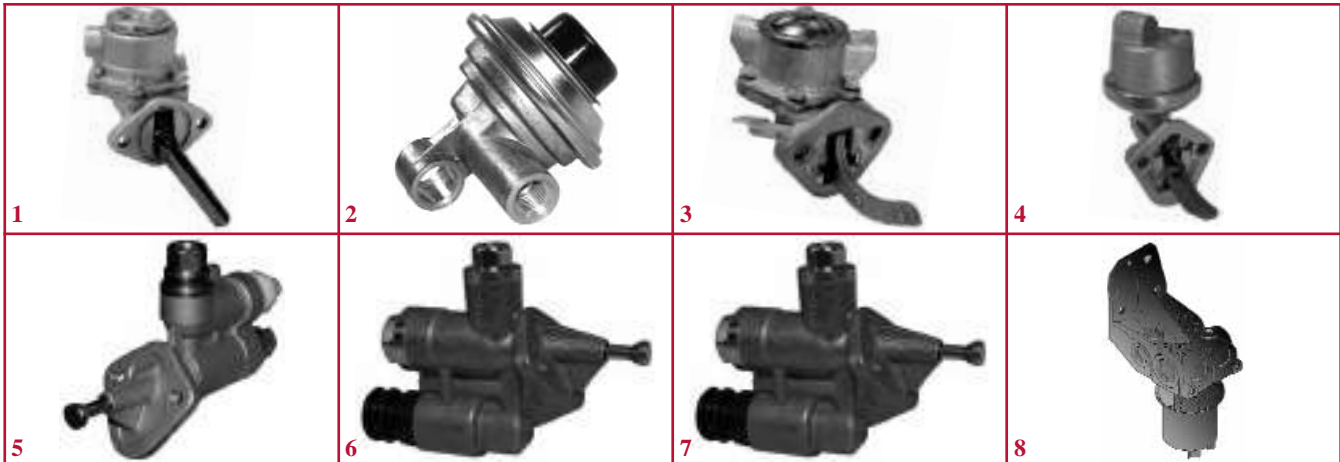

KRAFTSTOFFFÖRDERPUMPEN

Motoren IH

Bestell-Nr.	Abb.	Schleppertyp	Reparatursatz
25/100-24 (3132697R92, B503521)	1	454, 474, 574, 554, 624, 633, 644, 645, 654, 674, 724, 733, 740, 743, 744, 745, 756, 833, 840, 844, 845, 846, 856, 946, 955, 956, 1046, 1055, 1056, 1246, 1255, 1455	25/101-24 (3136002R91)
25/100-86 (1202938C92, 1202938C93)	2	433, 440, 485, 495, 533, 540, 585, 595, 633, 640, 685, 695, 733, 740, 785, 795, 833, 840, 885, 895, 933, 940, 995, 3210, 3220, 3230, 4210, 4220, 4230, 4240	
25/100-22 (708294R93)	3	250, B275, 276, 354, 374, 384, B414, 434, 444 <i>Motoren BD144, BD154 motoren</i>	25/101-22 (3066010R92)

Motoren Cummins

Bestell-Nr.	Abb.	Schleppertyp	OEM
25/100-35	4	1896, 5120, 5130, 5140, 5150, 5220, 5230, 5240, 5250	J904374, J928143
25/100-107	5	7110, 7120, 7130, 7140, 7150, 7210 7220, 7230, 7240, 7250 (⇒ JJA0064977) 9110, 9130, 9210, 9230, 9240 9310 (⇒ JEE0036500), 9330	J917998, J933254, J930201, J906795
25/100-108	6	7220, 7230, 7240, 7250 (JJA0064978 ⇒) 8910, 8920, 8930, 8940, 8950 9310 (JEE0036501 ⇒) MX180, MX200, MX210, MX220, MX230	J936316, J925709, J933252, J930566
25/100-109	7	MX100, MX110, MX120, MX135, MX150, MX170	J936317, J933253, J930135, J926034, J921550
25/100-110	8	MX240, MX255, MX270, MX285	J949093, J944386

Mähdrrescher

25/100-107	5	1660, 1666, 1670, 1680, 2166	J917998, J933254, J930201, J906795
25/100-109	7	2344, 2365 2366 (⇒ 177699), 2388 (⇒ 272999)	J936317, J933253, J930135, J926034, J921550
25/100-108	6	2365 2366 (177700 ⇒), 2388 (273000 ⇒)	J936316, J925709, J933252, J930566

Wir vertreiben keine Originalteile.
Die Nummern dienen lediglich als Beschreibung.

"THE RELIABLE SERVICE"

KRAFTSTOFFFÖRDERPUMPEN

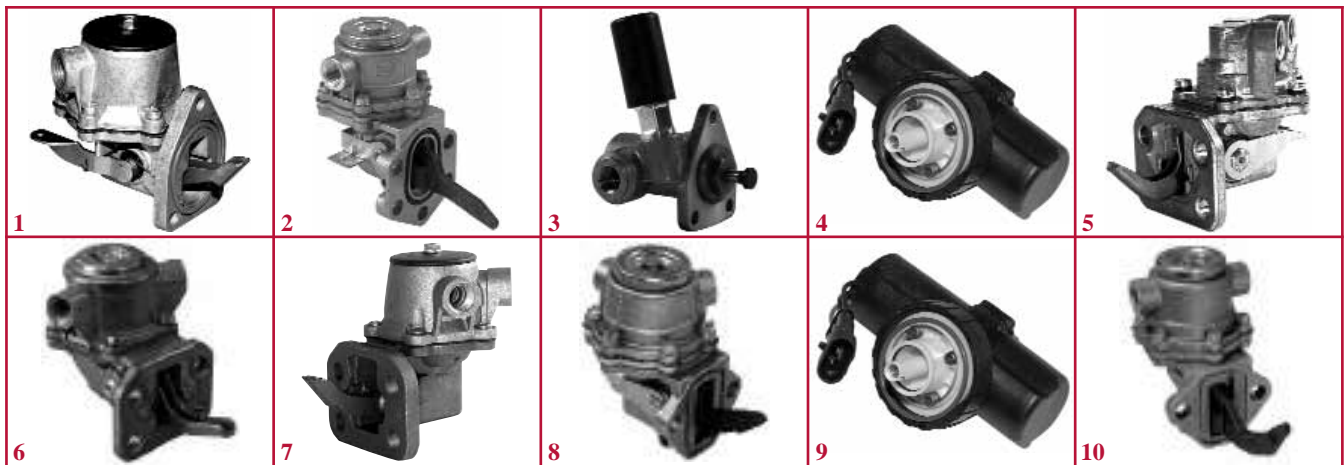

Motoren MWM

Bestell-Nr.	Abb.	Schleppertyp	Reparatursatz
25/100-100 (130100080733)	1	C55, C55A, C64, C64A, C70A CS68, CS75, CS78, CS86, CS94 (⇒ 12/98)	25/101-100 130100080735

Motoren Sisu

Bestell-Nr.	Abb.	Schleppertyp	OEM
25/100-78	2	CS68, CS75, CS78, CS86, CS94 (01/99 ⇒) CS100, CS110, CS120, CS130, CS150 (DBD0075001 ⇒) CVX120, CVX130, CVX150, CVX170	354236A1, 142000080734
25/100-101	3	CS110, CS120, CS130, CS150 (⇒ DBD0015200)	162000080710, 162000080825
25/100-102	4	CVX1135, CVX1145, CVX1155, CVX1170, CVX1190	162000080883

Motoren Perkins

Bestell-Nr.	Abb.	Schleppertyp	OEM
25/100-103	5	C50, C60, CS48, CS52, CS58, CS63, CX50, CX60	296265A1, 130300080739
25/100-23	6	475	3118234R91
25/100-104	7	C70, C80, C90, CX70, CX80, CX90, CX100, MX80C, MX90C, MX100C	295976A1

Motoren Iveco

Bestell-Nr.	Abb.	Schleppertyp	OEM
25/100-105	8	AVJ55, AVJ60, AVJ70, JX55, JX60, JX65, JX70, JX70U, JX75, JX80, JX80U, JX85, JX90, JX90U, JX95, JX100U, JX1060C, JX1070C, JX1075C, VJ60, VJ70, VJ80	4757883

Motoren Ford

Bestell-Nr.	Abb.	Schleppertyp	OEM
25/100-106	9	MXM120, MXM130, MXM135, MXM140, MXM150, MXM155, MXM165, MXM175, MXM180, MXM190	87802238

Motoren Same

Bestell-Nr.	Abb.	Schleppertyp	OEM
25/100-59	10	2120, 2120 PRO, 2130, 2130 PRO, 2140, 2140 PRO, 2150, 2150 PRO, PJ55, PJN55, PJV55, PJ65, PJN65, PJV65, PJ75, PJN75, PJV75	1966518C1

Wir vertreiben keine Originalteile.
Die Nummern dienen lediglich als Beschreibung.



"THE RELIABLE SERVICE"



GLÜHKERZEN & FLAMMGLÜHKERZEN

Bestell-Nr.	Abb.	Beschreibung	Motoren	Schleppertyp	OEM
Motoren IH					
25/60-13	1	M18 x 1.5 9.5 V Parallele	D111	D324, D326, 323	3054716R92
			D148	D436, D438, D439	
25/60-8	2	M18 x 1.5 0.9 I Serie	BD144	B275, 276, 354	710348R1
			BD154	238, 374, 384, B414, 424, 434, 444	
25/60-9	3	Steckanschluss 7/8" UNF		385, 395, 454, 474, 475, 484, 485, 495, 574, 584, 585, 595, 674, 684, 685, 695, 784, 785, 795, 884, 885, 895, 3210, 3220, 3230, 4210, 4220, 4230, 4240	3112805R91
25/60-10	4	Schraubanschluss 7/8" UNF			K928523, 3118299R1
Motoren Cummins					
25/60-9	3	Steckanschluss 7/8" UNF		5120, 5130, 5140, 5150, MX100, MX110, MX120, MX135	A77616
Motoren MWM					
25/60-43	5			C55, C64, C70, CS68, CS75, CS78, CS86, CS94	130100090003
Motoren Sisu					
25/60-9	3	Steckanschluss 7/8" UNF		CS68, CS75, CS78, CS86, CS94 (01/99 ⇒) CS100, CS110, CS120, CS130, CS150	162000090701
Motoren Perkins / Perkins motoren					
25/60-9	3	Steckanschluss 7/8" UNF		C50, C60, C70, C80, C90, CS48, CS52, CS58, CS63, CX50, CX60, CX70, CX80, CX90, CX100, MX80C, MX90C, MX100C	A77616, 218349A1
25/60-10	4	Schraubanschluss 7/8" UNF		475 (Perkins A4.212)	3118299R1
Motoren Iveco / Iveco motoren					
25/60-40	3	Steckanschluss 1/2" BSP		AVJ55, AVJ60, AVJ70, JX55, JX60, JX65, JX70, JX70U, JX75, JX80, JX80U, JX85, JX90, JX90U, JX95, JX100U, JX1060C, JX1070C, JX1075C	5161845 5086043
Motoren Ford / Ford motoren					
25/60-41	3	Steckanschluss 7/8" UNF		MXM120, MXM130, MXM135, MXM140, MXM150, MXM155, MXM165, MXM175, MXM180, MXM190	87800843

Bestell-Nr.	Beschreibung	Schleppertyp	Abb.
63/974-1	Vorglühanzeige	DLD2, D212, D214, D215, D217F, D217S, D219, DED3, D320, D322, D324, D326, DGD4, D430, D432, D436, D439, D440	

Wir vertreiben keine Originalteile.
Die Nummern dienen lediglich als Beschreibung.



"THE RELIABLE SERVICE"



WASSERPUMPEN & REPARATURSÄTZE
Motoren IH

Wasserpumpe	Reparatursatz	Motoren	Schleppertyp	Abb.		
25/130-56 (718891R97, 716410R98)	25/131-56 (3052183R93)	D66 D74 D99 D111 D132 D148	D212, D214, D215, D217, D219, D320, D322, D324, D326, D430, D432, D436, D439, D440, DED, DED 3, DGD-4, DLD-2, 323			
25/130-57 (763613R95)			135D, 137 CIMA (France)			
25/130-25 (3065132R92, 3119778R92, 703820R95)	25/131-25 (1094021R91)	BD144 BD154	B275, 276, 354, 374, 384, B414, 424, 434, 444			
25/130-59 (E) (3132741R93) A = 110 mm B = 112 mm	25/131-28 (3055285R94) B = 112 mm	D155 D179 D206 D239 D246 D268 DT239	353, 383, 423, 433, 453, 523, 533, 553, 624, 633, 724, 644, 645, 733, 743, 745, 744, 824, 844, 844S, 845, 856			
25/130-58 (E) (3136217R92, 3132738R93) A = 110 mm B = 98 mm					25/131-27 (1094012R91) B = 98 mm	25/133-1 Dichtung (764954R1) Mit Motoren D155, D179, D206, D239, D246, D268
25/130-29 (E) (3138936R92) A = 100 mm	25/131-28 (3055285R94) B = 112 mm	D310 D358 DT358 DT402	946, 955, 956, 1046, 1055, 1056, 1246, 1255, 1455			
25/130-30 (E) (3132676R93) Welle : 16 mm A = 78 mm					25/130-29 Schlep. stand. 25/130-30 Mit Kompressor 25/130-60 Mit Klimaanlage	
25/130-60 (3144661R93) Welle / As : 24 mm						
25/130-28 (E) (3136053R92, 3132739R93) A = 107 mm B = 112 mm	25/131-27 (1094012R91) B = 98 mm	D155 D179 D206 D239 D246 D268 DT268	385, 395, 454, 474, 484, 485, 495, 574, 585, 585, 595, 674, 684, 685, 695, 784, 785, 795, 884, 885, 895, 995, HYDRO 85 3210, 3220, 3230, 4210, 4220, 4230, 4240			
	25/131-28 (3055285R94) B = 112 mm				25/133-1 Dichtung (764954R1) Mit Motoren D155, D179, D206, D239, D246, D268	

(A) Wellendurchmesser



(B) Durchmesser des Schaufelrades

Wir vertreiben keine Originalteile.



Die Nummern dienen lediglich als Beschreibung.

"THE RELIABLE SERVICE"



WASSERPUMPEN & REPARATURSÄTZE
WATERPOMPEN
Motoren Cummins

Wasserpumpe	Reparatursatz	Motoren	Schleppertyp	Abb.
25/130-61 (A77703, J802358, J802970, J286277) B = 82 mm		4T390	5120, 5220	
		6-590	5130, 5230	
		6T590	5140, 5150, 5240, 5250, MX100, MX110, MX120, MX135, MX150, MX170	
		6T830	9110, 9130 (JCB0003600 ⇒)	
25/130-62 (A77579, A77704, J800974, J800976, J802479)		6T830	7110, 7120, 7130, 7140, 7150, 7210, 7220, 7230, 7240, 7250, 8910, 8920, 8930, 8940, 8950 9110, 9130 (⇒ JCB0003600) 9210, 9230, 9240, 9310, 9330, MX180, MX200, MX220	
		6T830	MX210, MX230, MX240, MX255, MX270, MX285	
25/130-232 (J804927)		6T830	MX210, MX230, MX240, MX255, MX270, MX285	

Mähdrescher

25/130-61 (A77703, J802358, J802970, J286277)		6T590	1620, 1640, 1644, 2144, 2344	
25/130-62 (A77579, A77704, J800974, J800976, J802479, J802975)		6T830	2365, 2366, 2388, CF60	

Motoren MWM

Wasserpumpe	Reparatursatz	Motoren	Schleppertyp	Abb.
25/130-216 (130100060703, 299671A1)		D 226-B 3	C55, C55A	
		TD 226-B 3	C64, C64A, C70A CS68, CS75 (⇒ 12/98)	
		TD 226-B 4	CS78, CS86, CS94 (⇒ 12/98)	

- (A) Wellendurchmesser
 (B) Durchmesser des Schaufelrades



Wir vertreiben keine Originalteile.
 Die Nummern dienen lediglich als Beschreibung.

"THE RELIABLE SERVICE"

WASSERPUMPEN & REPARATURSÄTZE
Motoren Sisu

Wasserpumpe	Reparatursatz	Motoren	Schleppertyp	Abb.
25/130-233 (354190A1, 354273A1)	25/131-233 (162000060745)	320D	CS68, CS75 (01/99 ⇒)	
		420D	CS78, CS86, CS94 (01/99 ⇒)	
25/130-218 (162000060735)	25/131-218 (162000060745) Nur passend zu 25/130-218	420D	CS100, CS110	
25/130-219 (162084060704)	25/131-219 (162084060712)	620D	CS120, CS130, CS150	
25/130-234 (162000060750)	25/131-234 (162000060751)	620D	CVX120, CVX130, CVX150, CVX170, CVX1135, CVX1145, CVX1155, CVX1170, CVX1190	

Motoren Perkins

Wasserpumpe	Reparatursatz	Motoren	Schleppertyp	Abb.
25/130-26 (3118125R91)	25/131-26 (3118126R91)	A4.212	475	
25/130-227 (293515A1) erste Montage	25/131-227 (281656A1)	1004.4T	C80, C90, CX80, CX90, CX100 (⇒ JEE008568)	
25/130-228 (311781A1) zweite Montage		1004.4T	C70, CX70 C80, C90, CX80, CX90, CX100 (JEE008569 ⇒) MX80C, MX90C, MX100C	

Wir vertreiben keine Originalteile.
 Die Nummern dienen lediglich als Beschreibung.

"THE RELIABLE SERVICE"

WASSERPUMPEN & REPARATURSÄTZE
Motoren Iveco

Wasserpumpe	Reparatursatz	Motoren	Schleppertyp	Abb.
25/130-235 (99454833)	25/131-235 (1940144)	8035.06	AVJ55, JX55	
		8035.05	AVJ60, JX60, JX65, JX70, JX1060C, JX1070C, JX1075C	
		8045.06	AVJ70, JX70U, JX75	
		8045.05	JX80, JX80U, JX85, JX90, JX90U, JX95, JX100U	

Motoren Ford

Wasserpumpe	Reparatursatz	Motoren	Schleppertyp	Abb.
25/130-236 (87802491)	25/131-236 (87802496) Schaufelrad Ø126 mm	675/TA	MXM120, MXM130	
25/130-237 (87802490)			MXM140, MXM155, MXM175, MXM190	
25/130-242 (87802436)	MXM135			
25/130-243 (87802437)	MXM150, MXM165, MXM180			

BY-PASS-SCHLÄUCHE FÜR WASSERPUMPEN

Bestell-Nr.	Schleppertyp	OEM	Abb.
25/142-5	238, 248, 258, 268, 278, 288, 385, 395, 474, 484, 485, 485XL, 495, 495XL, 584, 585, 585XL, 595, 595XL, 684, 685, 685XL, 695, 695XL, 784, 785, 785XL, 795, 795XL, 884, 885, 885XL, 895, 895XL, 995, 995XL, 3210, 3220, 3230, 4210, 4220, 4230, 4240	3144028R1	
25/142-6	353, 383, 423, 433, 440, 453, 533, 540, 644, 654, 733, 740, 946, 955, 1046	3132719R1	
25/141-9	354, 364, 374, 384, B414, 424, 434, 444, 2276, 2300, 2350, 3434,	3065127R1 3065127R91	
25/142-4	454, 574, 674, 2400, 2500	3132144R1	
25/142-7	553, 633, 640, 724, 743, 743XL, 744, 745S, 745XL, 824, 833, 840, 844, 844S, 844XL, 845, 845XL, 856XL, 940, 956, 956XL, 1055, 1056, 1056XL, 1246, 1255, 1255XL, 1455, 1455XL	3132720R1	
25/142-32	C55, C64, C70, CS68, CS75, CS78, CS86, CS94	130100190705	

Wir vertreiben keine Originalteile.
Die Nummern dienen lediglich als Beschreibung.

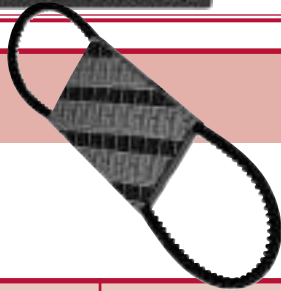

"THE RELIABLE SERVICE"

KEILRIEMEN

Drehstromlicht.	Wasserpumpe	Lüfter	Klimaanlage	Druckluftkompressor	Schleppertyp
	25/144-26 (3129140R1, 3125249R1, 527470R1)				238, 248, 258, 268, 278, 288, 395, 484, 485XL, 495, 495XL, 574, 584, 674, 684, 784, 785, 795, 884, 3210, 4210, 4220, 4230, 4240
			25/144-183 (84657C1)		585, 585XL, 595, 595XL, 685, 685XL, 695, 695XL, 785XL, 795XL, 885, 885XL, 895, 895XL, 995XL, 3220, 3230
25/144-11 (704449R1)					B275, B414
		25/144-23 (3060464R1, 709502R1)			276, 354, 364, 434, 444, 2276, 2300, 2350, 3434
					374, 384
	25/144-24 (3055715R1, 3116685R1)				323, 353, 383, 423, 433, 453, 553, 654, 724, 824 (GleichstromLicht 11A) 475, 533, 633, 644, 733, 743, 744, 745S, 833, 844, 844S
	25/144-130 (3144678R1)				323, 383, 423, 453 (GleichstromLicht 16A) 440, 540, 640, 740, 743, 743XL, 745S, 745XL, 840, 844S, 844XL, 845, 845XL, 856XL, 940
	25/144-25 (3113329R1, 3129139R1)				385, 454, 484, 485, 485XL, 585XL, 995, 2400
	25/144-28 (3136258R1)				553, 654, 724, 824 (GleichstromLicht16A)
				25/144-185 (897505H1)	946, 955, 955XL, 956, 956XL, 1046, 1055, 1055XL, 1056, 1056XL, 1246
	25/144-131 (385120R2)				856, 1026, 1256, 1456
	25/144-132 (1537104C1)		25/144-183 (84657C1)		885, 995
	25/144-27 (3138935R1, 3218952R1)				946, 955, 955XL, 1046, 1055, 1055XL, 1246
					1255, 1255XL, 1455, 1455XL
	25/144-133 (3218043R1)				
	25/144-27 (3138935R1, 3218952R1)			25/144-186 (1329161C1)	956, 1056
					956XL, 1056XL
25/144-134 (3228279R1)	25/144-135 (3228287R91, 3228421R1)		25/144-184 (1806189C1)		956XL, 1056XL, 1255XL, 1455XL
	25/144-28 (3218951R1)			25/144-187 (3228131R1)	1255, 1255XL, 1455, 1455XL

Wir vertreiben keine Originalteile.
Die Nummern dienen lediglich als Beschreibung.

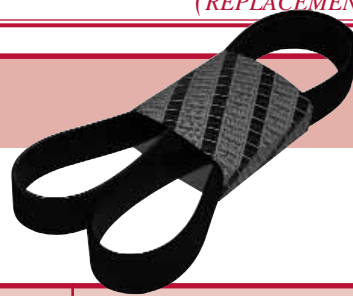
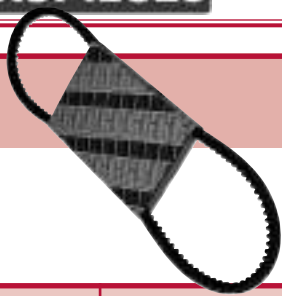
"THE RELIABLE SERVICE"

KEILRIEMEN

Drehstromlicht.	Wasserpumpe	Lüfter	Klimaanlage	Druckluftkompressor	Schleppertyp
25/144-136 (401942A1) Mit Klimaanlage		25/144-138 (1966513C1)	25/144-188 (341530A1)		2120, 2130
25/144-137 (404398A1) Ohne Klimaanlage		25/144-139 (1966512C1)			2140, 2150
25/144-26 (3129140R1, 3125249R1, 527470R1)			25/144-183 (84657C1)		3220, 3230
					3210, 4210, 4220, 4230, 4240
25/144-132 (1537104C1)			25/144-183 (84657C1)		4240
25/144-89 (J911558)			25/144-69 (A184652)	25/144-193 (D136236)	5120, 5130
					5220, 5230
25/144-90 (J911562)			25/144-68 (84766C1)		5140, 5150, 5240, 5250
25/144-140 (J911567)			25/144-189 (131403C1)		7110, 7120, 7130, 7140, 7150
				25/144-194 (235414A1, A189039)	7210, 7220, 7230, 7240, 7250
					8910, 8920, 8930, 8940, 8950
25/144-141 (J905866)			25/144-190 (6-1451)		9110, 9130 (⇒ JCB0003599)
25/144-142 (J911572)					9110, 9130 (JCB0003600 ⇒)
		25/144-191 (90-7729T1)			9210, 9230, 9240, 9310, 9330
25/144-143 x 2 (218509A1)					C50, C60
25/144-144 (259289A1)					
25/144-145 (141100060014)			25/144-147 (130100130041)		C55, C55A, C64, C64A, C70A
25/144-146 (238990A1)			25/144-192 (228332A2)		C70, C80, C90
25/144-147 (130300060002)					CS48, CS52, CS58, CS63

Wir vertreiben keine Originalteile.
 Die Nummern dienen lediglich als Beschreibung.



“THE RELIABLE SERVICE”

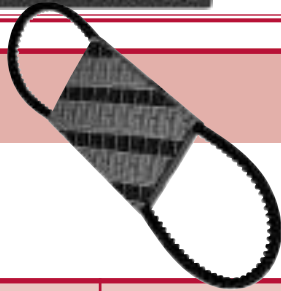

KEILRIEMEN

Drehstromlicht.	Wasserpumpe	Lüfter	Klimaanlage	Druckluftkompressor	Schleppertyp
			25/144-164 (140100130132)		CS68, CS75 (motor MWM)
			25/144-195 (140100130131)		
			25/144-28 (130100130071)		CS78, CS86, CS94 (⇒ 02953) (motor MWM)
	25/144-145 (141100060014) Ausser CS94		25/144-164 (140100130132)		CS78, CS86, CS94 (02954 ⇒) (motor MWM)
			25/144-196 (130100130072)		CS78, CS86, CS94 (⇒ 02115) (motor MWM)
			25/144-195 (140100130131)		CS78, CS86, CS94 (02116 ⇒) (motor MWM)
	25/144-148 (140100060001)				CS94 (motor MWM)
	25/144-149 x 2 (140100060002)				CS94 (motor MWM)
	25/144-160 x 2 (132000060012)				CS68, CS75 (motor Sisu)
	25/144-161 x 2 (142000060011)		25/144-197 (132000130020)	25/144-164 (140100130132)	CS68, CS75, CS78, CS86, CS94 (motor Sisu)
	25/144-162 x 2 (142000060012)		25/144-198 (162000130004)		
			25/144-164 (140100130132)		
	25/144-163 x 2 (139900130003)			25/144-135 (162000060005)	CS100, CS110 (DBD0075001 ⇒)
	25/144-164 (142000060001)		25/144-199 (142000130004)	25/144-135 (162000060005)	CS110
			25/144-410 (142000130005)		
			25/144-198 (162000130004)	25/144-412 (162000130003)	CS120, CS130, CS150
	25/144-27 (162000060001)		25/144-411 (162000130007)		CS120
	25/144-165 (162000060006)				CS130, CS150

Wir vertreiben keine Originalteile.
Die Nummern dienen lediglich als Beschreibung.

"THE RELIABLE SERVICE"

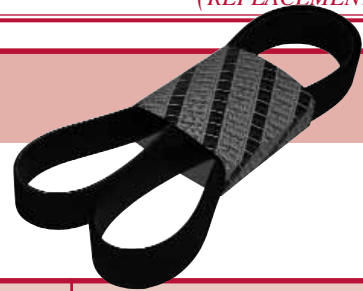
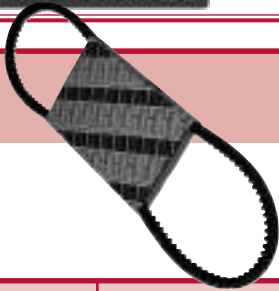
KEILRIEMEN

Drehstromlicht.	Wasserpumpe	Lüfter	Klimaanlage	Druckluftkompressor	Schleppertyp
	25/144-166 x 2 (162000060007)		25/144-413 (162000130046)	25/144-135 (162000060005)	CVX120, CVX130, CVX150, CVX170
			25/144-414 (162000130074)		CVX1135, CVX1145, CVX1155, CVX1170, CVX1190
	25/144-143 (218509A1)		25/144-415 (238215A3)		CX50, CX60
	25/144-144 (259289A1)				
	25/144-167 x 2 (241895A2)		25/144-192 (228332A2)	25/144-420 (293956A1)	CX70, CX80, CX90, CX100
	25/144-168 x 2 (389069A1)		25/144-416 (248265A2)		
	25/144-169 (5088081)	25/144-171 (5094418)	25/144-417 (5140009)		JX55, JX60, JX65, JX70, JX75, JX80, JX85, JX90, JX95
	25/144-170 (4796327)	25/144-172 (5140010)			
	25/144-173 (98432118)				JX55, JX65, JX75, JX85 (⇒ 13286)
	25/144-174 (98473705)		25/144-417 (5140009) JX70U, JX80U		JX55, JX65 (13287 ⇒) JX60, JX70, JX70U, JX80U, JX90U, JX100U
	25/144-175 (500369112)		25/144-418 (5186233) JX90U, JX100U		JX75, JX85 (13287 ⇒) JX80, JX90, JX95, JX70U, JX80U, JX90U, JX100U
	25/144-174 (98473705)		25/144-419 (5154152)		JX1060C, JX1070C, JX1075C
	25/144-176 (4796328)				
25/144-136 (401942A1) Mit Klimaanlage		25/144-138 (1966513C1)	25/144-188 (341530A1)		PJ55, PJN55, PJV55
25/144-137 (404398A1) Ohne Klimaanlage		25/144-139 (1966512C1)			PJ65, PJ75, PJN65, PJN75, PJV65, PJV75
	25/144-167 x 2 (241895A2)		25/144-416 (248265A2)	25/144-420 (293956A1)	MX80C, MX90C, MX100C
	25/144-168 x 2 (389069A1)			25/144-421 (294462A1) Mit Klimaanlage	

Wir vertreiben keine Originalteile.
Die Nummern dienen lediglich als Beschreibung.



"THE RELIABLE SERVICE"

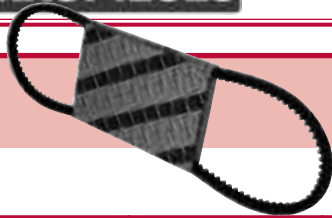

KEILRIEMEN



Drehstromlicht.	Wasserpumpe	Lüfter	Klimaanlage	Druckluftkompressor	Schleppertyp
	25/144-89 (J911558) Ausser MX150, MX170		25/144-69 (A184652) Ausser MX150, MX170		MX100, MX110, MX120, MX135, MX150, MX170
	25/144-90 (J911562)		25/144-68 (84766C1)	25/144-422 (228316A1) Mit Klimaanlage 25/144-421 (294462A1) Ohne Klimaanlage	
				25/144-425 (255402A1)	MX150, MX170
	25/144-177 (243372A1)		25/144-423 (A189040)	25/144-426 (385738R1)	MX180, MX200, MX220
	25/144-178 (87402830)			25/144-427 (86989142)	MX210, MX230, MX240
	25/144-179 (243373A1)		25/144-424 (320344A1)	25/144-426 (385738R1)	MX240, MX270
	25/144-180 (87402831)			25/144-427 (86989142)	MX255, MX285
	25/144-181 (87802822)			25/144-428 (82021010)	MXM120, MXM130, MXM140, MXM155, MXM175, MXM190
	25/144-182 (87800858)				MXM135, MXM150, MXM165, MXM180

KEILRIEMEN-SPANNROLLE

Bestell-Nr.	Schleppertyp	OEM	Abb.
25/135-1	5120, 5130, 5140, 5150, 5220, 5230, 5240, 5250, 7110, 7120, 7130, 7140, 7150, 7210, 7220, 7230, 7240, 7250, 8910, 8920, 8930, 8940, 8950, 9110, 9130, 9210, 9230, 9240, 9310, 9330, MX100, MX110, MX120, MX135, MX150, MX170, MX180, MX200, MX220, MX240, MX270	J912246, J911315, J936203, J934817, J918944, J914086	
25/135-15	MXM120, MXM130, MXM140, MXM155, MXM175, MXM190	87801838 87840057	
25/135-16	WDX901, WDX1101	87801689 87800708	

Wir vertreiben keine Originalteile.
Die Nummern dienen lediglich als Beschreibung.

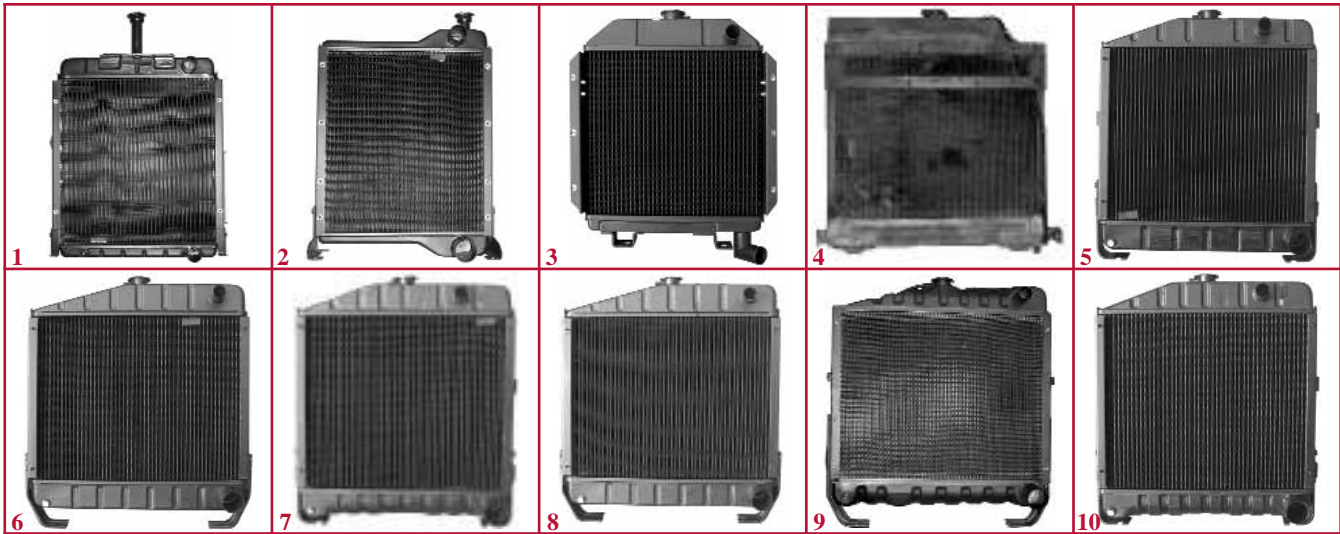
"THE RELIABLE SERVICE"



KÜHLER

Bestell-Nr.	Abb.	Beschreibung	L x l x H mm	Schleppertyp	OEM
25/150-74	1		485 x 70 x 570	238, 248, 258, 268, 288, 385, 395, 484, 485, 485XL, 495, 495XL, 584, 585, 585XL, 595, 595XL, 684, 685, 685XL, 695, 695XL, 784, 785, 785XL, 795, 795XL, 885, 885XL, 895, 895XL, 995	84524C93, 3121413R91, 3121414R92, 1536373C1
25/150-73	2		472 x 109 x 629	288, 485XL, 585, 585XL, 595, 595XL, 685, 685XL, 695, 695XL, 785, 785XL, 795, 795XL, 885, 885XL, 895, 895XL	84673C3, 84673C4, 84673C5, 84673C6
25/150-55	3		405 x 94 x 475	353, 353E, 383, 383E, 423, 423E	3131579R91, 787141R92
25/150-141	4		518 x 100 x 564	523, 624	787605R92
25/150-53	5	Ersetzt 'Chausson' - 'Windhoff'	491 x 77 x 534	533, 533E, 533V, 540, 633, 633E, 633V, 640	3148115R93, 3148115R94, 3223389R91
25/150-52	6	Ersetzt 'Windhoff'	530 x 95 x 545	644	3145499R91, 3145499R92
25/150-50	7	Ersetzt 'Windhoff'	490 x 97 x 540	733, 740, 833E, 833V	3233229R91, 3233229R92
25/150-54	8	Ersetzt 'Chausson' - 'Windhoff'	530 x 95 x 547	743, 744, 745S, 844S, 845	3145498R93, 3147851R93
25/150-62	9	Ersetzt 'Windhoff'	530 x 95 x 545	743XL, 745XL, 844S, 844XL, 845, 845XL	3216849R92, 3399930R1, 3399928R1
25/150-51	10	Ersetzt 'Windhoff'	489 x 95 x 530	833, 840, 940	1328723C91, 1328723C92

Wir vertreiben keine Originalteile.
 Die Nummern dienen lediglich als Beschreibung.

"THE RELIABLE SERVICE"

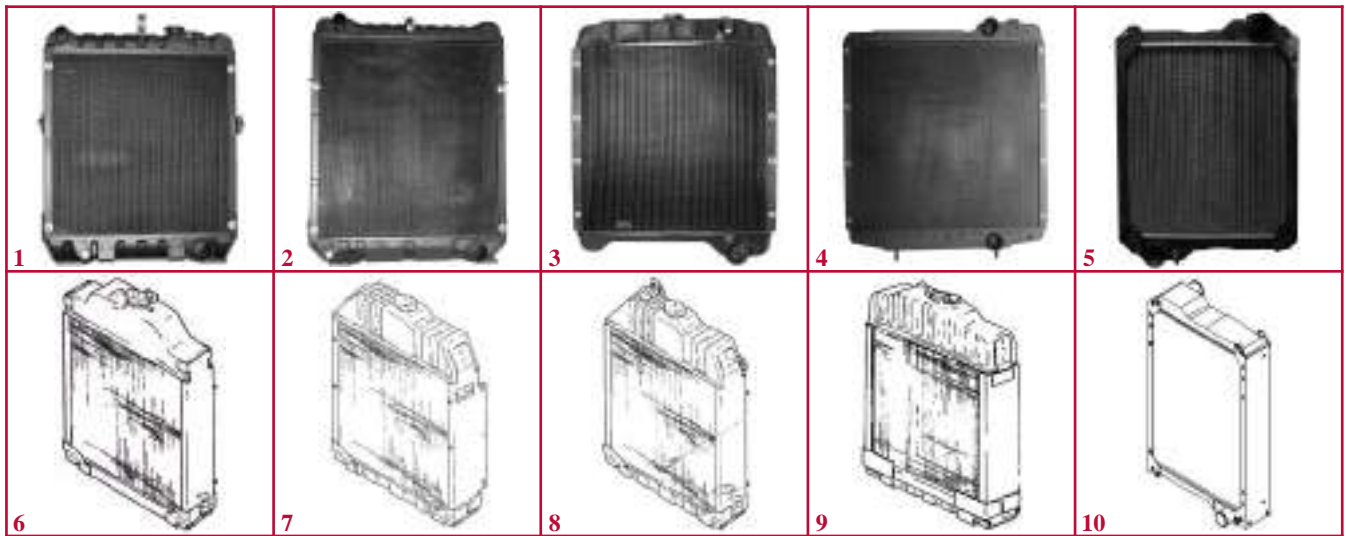
KÜHLER



Bestell-Nr.	Abb.	Beschreibung	L x l x H mm	Schleppertyp	OEM
25/150-85	1	Ersetzt 'Windhoff'		955XL, 956, 956XL, 1055XL, 1056, 1056XL	3399812R1
25/150-84	2			1255, 1255XL, 1455, 1455XL	3226796R92
25/150-56	3		538 x 129 x 643	5120, 5130, 5140, 5150, 5220, 5230, 5240, 5250	104753A1, 104753A2
25/150-130	4			7110, 7120, 7130, 7140, 7210, 7220, 7230, 7240	A190663
25/150-131	4			7150, 7250	A190807
25/150-157	5			C50, C60, C70, C80, CX50, CX60, CX70, CX80, CX90	222890A5
25/150-142	6	Motor MWM	485 x 117 x 648	C64, C64A, C70A	1-33-153-001, 1-33-153-060
25/150-146	7	Motor Perkins	485 x 117 x 554	CS48, CS52, CS58	130300530001
25/150-143	8	Motor MWM	485 x 117 x 519	CS68, CS75	1-33-153-016, 1-33-153-216
25/150-144	9	Motor MWM	485 x 117 x 798	CS78, CS86, CS94	1-33-153-018, 1-33-153-218
25/150-161	10		590 x 135 x 565	MX100, MX110, MX120, MX135, MX150, MX170	135691A3

KÜHLERDÄMPFER

Bestell-Nr.	Schleppertyp	OEM	Abb.
25/4114-10	AVJ55, AVJ60, AVJ70, JX55, JX60, JX65, JX70, JX75, JX80, JX85, JX90, JX95, JX70U, JX80U, JX90U, JX100U, JX1070U, JX1080U, JX1090U, JX1100U, JX1060C, JX1070C, JX1075C, JX1085C, JX1095C, JX1060V, JX1070N, JX1070V, JX1075N, JX1075V, JX1095N, JX1095V, MXM135, MXM150, MXM165, MXM180, VJ60, VJ70, VJ80	5108225	

Wir vertreiben keine Originalteile.
Die Nummern dienen lediglich als Beschreibung.



"THE RELIABLE SERVICE"



KÜHLERDECKEL

1

2

3

Bestell-Nr.	Abb.	Beschreibung	Schleppertyp	OEM
25/151-11	1	Ø52-68 / 7 lbs	B275, 276, 354, 364, 374, B414, 434, 444, 475, 2300, 2350	3111424R91, 3064970R91, 3047378R91
25/151-13	2	Ø38-56 / 7 lbs	323, 383, 423, 433, 440, 453, 533, 540, 553, 633, 640, 644, 654, 724, 733, 740, 743, 744, 745S, 824, 833, 840, 844, 845, 856, 955, 956, 1046, 1055, 1056, 1246, 1255, 1455	787151R91, 3134146R1
25/151-12	2	Ø38-56 / 10 lbs	248, 258, 268, 278, 385, 454, 464, 474, 484, 485, 495, 574, 584, 585, 595, 674, 684, 685, 784, 785, 884, 885, 2400, 2500, 3210, 3220, 3230, 4210, 4220, 4230, 4240	532029R1, 1500626C92
25/151-33	2	Ø38-56 / 13 lbs	1896, 2096, 5120, 5130, 5140, 5150, 5220, 5230, 5240, 5250, 7110, 7120, 7130, 7140, 7150, 7210, 7220, 7230, 7240, 7250, 8910, 8920, 8930, 8940, 8950, 9240, 9310, 9330, C50, C60, C70, C80, C90, CX50, CX60, CX70, CX80, CX90, CX100, MX100, MX110, MX120, MX135, MX150, MX170, MX180, MX200, MX210, MX220, MX230, MX240, MX255, MX270, MX285, MX80C, MX90C, MX100C Mährescher 1620, 1640, 1644, 1660, 1666, 1670, 1680, 1688, 2144, 2166, 2188, 2344, 2365, 2366, 2388	A170241, A171919
25/151-34	2	Ø38-56 / 7 lbs	C55, C55A, C64, C64A, C70A, CS48, CS52, CS58, CS63, CS68, CS75, CS78, CS86, CS94	1-33-753-001
25/151-35	2	Ø38-56 / 7 lbs	CS100, CS110, CS120, CS130, CS150, CVX120, CVX130, CVX150, CVX170	162000530701
25/151-34	2	Ø38-56 / 7 lbs	AVJ55, AVJ60, AVJ70, JX100U, JX55, JX60, JX65, JX70, JX70U, JX75, JX80, JX80U, JX85, JX90, JX90U, JX95, JX1060C, JX1060V, JX1070C, JX1070N, JX1070U, JX1070V, JX1075C, JX1075N, JX1075V, JX1080U, JX1085C, JX1090U, JX1095C, JX1100U, VJ60, VJ70, VJ80	4999682
25/151-33	2	Ø38-56 / 13 lbs	JX95	83935950
25/151-154	3	Ø56	MXM120, MXM130, MXM140, MXM155 (⇒ C4883) MXU100, MXU110, MXU115, MXU125, MXU135 (⇒ C4827)	82002652
25/151-36	2	Ø38-56 / 13 lbs	MXM175, MXM190	83957211

LÜFTERFLÜGEL

Bestell-Nr.	Beschreibung	Schleppertyp	OEM	Abb.
25/145-3	Ø 480 mm 8 Flügel 6 Bohrungen	946, 956, 956XL, 1046, 1056, 1056XL, 1246	3144584R1	
25/145-21	Ø 450 mm 5 Flügel 6 Bohrungen	553, 644, 654, 724, 743, 743XL, 744, 745S, 745XL, 824, 833, 844, 844S, 844XL, 845, 845XL	3218984R1 3055301R91	

Wir vertreiben keine Originalteile.
Die Nummern dienen lediglich als Beschreibung.



"THE RELIABLE SERVICE"



KÜHLERSCHLÄUCHE

Schlauch - Oben	Abb.	Schlauch - Unten	Abb.	Schleppertyp
25/153-24 (704289R1, 704289R2)	1	25/154-26 (704287R2)	3	B275 (⇒ 46506)
25/153-26 (3065130R1)	2			B275 (46507 ⇒) 2276
25/153-25 (3042414R1)	4	25/154-27 (3044009R1, 3112068R1)	5	B414 (⇒ 30924)
25/153-160 (1502065C1)	6	25/154-29 (402189R1)	8	238, 248, 385, 395, 485, 485XL, 495, 495XL, 585XL 484 (8169 ⇒)
25/153-29 (402191R1)	7			385, 454, 464, 485, 485XL, 2400 484 (⇒ 8168)
25/153-31 (402207R1)	9	25/154-31 (402205R1)	10	258, 268, 278, 288, 474, 485XL, 574, 584, 585, 585XL, 595, 595XL, 674, 684, 685, 685XL, 695, 695XL, 784, 785, 785XL, 795, 795XL, 884, 885, 885XL, 895, 895XL, 995, 2500
25/153-27 (3065129R1)	11	25/154-27 (3044009R1, 3112068R1)	5	276, 434, 3434 B414 (30925 ⇒)
25/153-28 (3112067R1)	12			354, 364, 374, 384, 444, 2300, 2350
25/153-90 (84496C1)	13	25/154-90 (84497C1, 84497C2)	14	288, 485XL, 585, 585XL, 595, 595XL, 685, 685XL, 695, 695XL, 785, 785XL, 795, 795XL, 885, 885XL, 895, 895XL
25/153-195 (787144R1)	15	25/154-195 (787143R1)	16	323
25/153-196 (787147R1)	17	25/154-161 (787146R1)	18	353, 423
25/153-33 (3134506R1)	19			353, E353, 383, 423, E423, 453
25/153-32 (3148117R1)	21	25/154-33 (3399199R1)	20	433, 533, 633, 733, 740, 833, 840, 940
25/153-32 (3148117R1)	21	25/154-32 (3216754R1)	22	433, 433E, 433V, 440, 533, 533E, 533V, 540, 633, 633E, 633V, 640, 733E, 733V
25/153-30 (3116665R1)	23	25/154-30 (3116664R1)	24	475
25/153-34 (3134507R1)	25	25/154-34 (3057428R1)	26	553, 644, 654, 724, 743, 743XL, 744, 745S, 745XL, 824, 844, 844S, 844XL, 845, 845XL, 856XL
25/153-33 (3134506R1)	19			844XL, 845XL
25/153-162 (3140981R1)	27	25/154-32 (3216754R1)	22	946, 1046
25/153-35 (3220434R1)	28	25/154-35 (3220435R1)	29	955, 955XL, 956, 956XL, 1055, 1055XL, 1056, 1056XL, 1246
		25/154-91 (3226798R1)	31	1255, 1255XL, 1455, 1455XL
25/153-91 (3404225R1)	30			1255XL, 1455XL (Mit Klimaanlage)
25/153-163 (1536489C1)	32	25/154-90 (84497C1, 84497C2)	14	995, 995XL
				3210, 3220, 4240 (⇒ JJE0910719)
25/153-90 (84496C1)	13			3230, 4210, 4220, 4230 (⇒ JJE0910719)

Wir vertreiben keine Originalteile.
Die Nummern dienen lediglich als Beschreibung.



"THE RELIABLE SERVICE"



KÜHLERSCHLÄUCHE

Schlauch - Oben	Abb.	Schlauch - Unten	Abb.	Schleppertyp
25/153-164 (180502A1)	33	25/154-164 (180501A3)	35	3210, 3220, 4240 (JJE0910720 ⇒)
25/153-165 (180503A1)	34			3230, 4210, 4220, 4230 (JJE0910720 ⇒)
25/153-125 (T103198)	36	25/154-125 (T103197)	37	5120, 5130, 5140, 5150, 5220, 5230, 5240, 5250
25/153-166 (1289072C1)	38	25/154-166 (1334477C1, 252305A1)	39	7110, 7120, 7130, 7140, 7150 7210, 7220, 7230, 7240, 7250 (⇒ JJA0064977)
25/153-167 (184299A1)	40	25/154-167 (186489A1)	41	7210, 7220, 7230, 7240, 7250 (JJA0064978 ⇒) 8930, 8940
		25/154-168 (235912A1, 254335A1)	42	8910, 8920, 8950
25/153-169 (5104825)	43	25/154-169 x 2 (596152)	44	AVJ55, AVJ60, AVJ70
25/153-170 (1-33-153-027)	45	25/154-170 x 2 (161000060224)	46	C55, C55A, C64, C64A, C70A
25/153-172 (224814A5)	47	25/154-172 (324817A1, 258749A4)	48	C70 C80 (JJE1006290 ⇒ JJE1008925) C90 (JJE1006290 ⇒ JJE1008984) C100 (JJE1006290 ⇒ JJE1008888)
		25/154-175 (335186A1)	49	C80 (JJE1008926 ⇒) C90 (JJE1008985 ⇒) C100 (JJE1008889 ⇒)
25/153-176 (130300530011)	50	25/154-176 (190003169634)	52	CS48, CS58
25/153-177 (130300530013)	51			CS52, CS63
25/153-171 (1-33-153-014)	53	25/154-170 x 2 (161000060224)	46	CS68, CS75, CS78, CS86, CS94 (Motor MWM)
25/153-178 (132000530004)	54	25/154-178 (132000530003)	55	CS68, CS75, CS78, CS86, CS94 (Motor Sisu)
25/153-179 (162000530009)	56	25/154-179 (162000530010) +	57	CS100, CS110
		25/154-180 (142000530011)	58	
		25/154-179 (162000530010) +	57	CS120, CS130, CS150
25/154-181 (162000530011)	59			
25/153-182 (162000530104)	60	25/154-182 (162000530103)	61	CVX120, CVX130, CVX150, CVX170, CVX1135, CVX1145, CVX1155, CVX1170, CVX1190
25/153-173 (224814A4)	62	25/154-172 (324817A1, 258749A4)	48	CX70 CX80 (⇒ JJE1008608) CX90 (⇒ JJE1008568) CX100 (⇒ JJE1008670) Standard Kühler
			49	CX80 (JJE1008609 ⇒) CX90 (JJE1008569 ⇒) CX100 (JJE1008671 ⇒) Standard Kühler
			63	CX90 (⇒ JJE1008568) CX100 (⇒ JJE1008670) Oben Kühler
			64	CX90 (JJE1008569 ⇒) CX100 (JJE1008671 ⇒) Oben Kühler

Wir vertreiben keine Originalteile.
Die Nummern dienen lediglich als Beschreibung.



"THE RELIABLE SERVICE"



KÜHLERSCHLÄUCHE

Schlauch - Oben	Abb.	Schlauch - Unten	Abb.	Schleppertyp
25/153-169 (5104825)	43	25/154-169 x 2 (596152)	44	JX55, JX60, JX65, JX70, JX75, JX80, JX85, JX90
				JX70U, JX80U, JX90U, JX100U
25/153-183 (5166566)	65	25/6002-183 (4997262) Fest	66	JX70U, JX80U, JX90U, JX100U (Ohne . . ¹)
25/153-184 (5090562)	67	25/154-169 x 2 (596152)	44	JX95
25/153-185 (5176675)	68			JX1060C, JX1060V, JX1070C, JC1070N, JX1070V, JX1075C, JX1075N, JX1075V, JX1095N, JX1095V
25/153-173 (224814A4)	62	25/154-173 (324818A1)	63	MX80C (⇒ JJE1052142) MX90C (⇒ JJE1052113) MX100C (⇒ JJE1052063) Oben Kühler
		25/154-174 (335187A1)	64	MX80C (JJE1052143 ⇒) MX90C (JJE1052114 ⇒) MX100C (JJE1052064 ⇒) Oben Kühler
25/153-186 (141569A2)	69	25/154-186 (141570A1)	70	MX100, MX110, MX120, MX135, MX150, MX170
25/153-187 x 2 (257281A1, 257281A2)	71	25/154-187 (226756A1, 226756A2)	72	MX180, MX200, MX220, MX240, MX270
25/153-188 (397511A1) +	73	25/154-188 (255682A1, 255682A2) +	74	MX210, MX230, MX255, MX285 MX240, MX270 (Ausser 25/153-190)
25/153-189 (414804A1) ⇒ JAZ135315	75		25/154-189 (255683A2)	
25/153-188 (397511A1) +	73	25/154-188 (255682A1, 255682A2)	74	
25/153-190 (87306058) JAZ135316 ⇒	77			
25/153-191 (82028240)	78	25/154-191 (82028242)	79	MXM120, MXM130, MXM140, MXM155
25/153-192 (82000889)	80	25/154-192 (82009831)	81	MXM135, MXM150, MXM165, MXM180
25/153-193 (82028241)	82	25/154-193 (82028242)	83	MXM175, MXM190
25/153-197 (82030134)	84	25/154-197 (82030135)	86	MXU100, MXU115 MXU100, MXU110, MXU115, MXU130 X-LINE
25/153-198 (82030133)	85			MXU110, MXU125, MXU135
25/153-169 (5104825)	43	25/154-169 x 2 (596152)	44	VJ60, VJ70, VJ80

Wir vertreiben keine Originalteile.
Die Nummern dienen lediglich als Beschreibung.



"THE RELIABLE SERVICE"



KÜHLERSCHLÄUCHE

1	25/153-24	2	25/153-26	3	25/154-26	4	25/153-25	5	25/154-27
6	25/153-160	7	25/153-29	8	25/154-29	9	25/153-31	10	25/154-31
11	25/153-27	12	25/153-28	13	25/153-90	14	25/154-90	15	25/153-195
16	25/154-195	17	25/153-196	18	25/154-161	19	25/153-33	20	25/154-33
21	25/153-32	22	25/154-32	23	25/153-30	24	25/154-30	25	25/153-34
26	25/154-34	27	25/153-162	28	25/153-35	29	25/154-35	30	25/153-91
31	25/154-91	32	25/153-163	33	25/153-164	34	25/153-165	35	25/154-164
36	25/153-125	37	25/154-125	38	25/153-166	39	25/154-166	40	25/153-167
41	25/154-167	42	25/154-168	43	25/153-169	44	25/154-169	45	25/153-170
46	25/154-170	47	25/153-172	48	25/154-172	49	25/154-175	50	25/153-176

Wir vertreiben keine Originalteile.
Die Nummern dienen lediglich als Beschreibung.



"THE RELIABLE SERVICE"



KÜHLERSCHLÄUCHE

51	25/153-177	52	25/154-176	53	25/153-171	54	25/153-178	55	25/154-178
56	25/153-179	57	25/154-179	58	25/154-180	59	25/154-181	60	25/153-182
61	25/154-182	62	25/153-173	63	25/154-173	64	25/154-174	65	25/153-183
66	25/6002-183	67	25/153-184	68	25/153-185	69	25/153-186	70	25/154-186
71	25/153-187	72	25/154-187	73	25/153-188	74	25/154-188	75	25/153-189
76	25/154-189	77	25/153-190	78	25/153-191	79	25/154-191	80	25/153-192
81	25/154-192	82	25/153-193	83	25/154-193	84	25/153-197	85	25/153-198
86	25/154-197								

Wir vertreiben keine Originalteile.
 Die Nummern dienen lediglich als Beschreibung.



"THE RELIABLE SERVICE"



KÜHLERSCHLÄUCHE - METERWARE

Bestell-Nr.	Ø innen		Bestell-Nr.	Ø innen		Abb.
	mm	Zoll		mm	Zoll	
70/155-16	16	5/8	70/155-30	30	1 1/8	
70/155-18	18	3/4	70/155-32	32		
70/155-19	19		70/155-35	35	1 1/4	
70/155-20	20		70/155-38	38		
70/155-22	22	7/8	70/155-40	40	1 1/2	
70/155-25	25	1	70/155-45	45	1 3/4	
70/155-28	28		70/155-50	50	2	

SCHLAUCHSCHELLEN

Bestell-Nr.	Ø Spannbereich		Bestell-Nr. <i>Bestel-Nr.</i>	Ø Spannbereich		Abb.
	mm	Zoll		mm	Zoll	
70/2940-012	9,5 - 12	3/8 - 1/2	70/2940-060	45 - 60	1 3/4 - 2 3/8	
70/2940-022	16 - 22	5/8 - 7/8	70/2940-070	55 - 70	2 - 2 3/4	
70/2940-025	18 - 25	3/4 - 1	70/2940-080	60 - 80	2 3/8 - 3 1/8	
70/2940-030	22 - 30	7/8 - 1 1/8	70/2940-090	70 - 90	2 3/4 - 3 1/2	
70/2940-035	25 - 35	1 - 1 3/8	70/2940-100	85 - 100	3 1/4 - 4	
70/2940-040	30 - 40	1 1/8 - 1 5/8	70/2940-120	90 - 120	3 3/4 - 4 1/2	
70/2940-050	35 - 50	1 1/4 - 1 7/8	70/2940-140	120 - 140	4 1/2 - 5 1/2	
70/2940-055	40 - 55	1 1/2 - 2 1/8	70/2940-160	140 - 160	5 1/2 - 6 1/4	





Wir vertreiben keine Originalteile.
 Die Nummern dienen lediglich als Beschreibung.





"THE RELIABLE SERVICE"



WASSERSAMMELROHR & ZUBEHÖR

Bestell-Nr.	Schleppertyp	Abb.
25/149-3 (3132718R1, 3218256R1)	323, 353, 383, 423, 433, 453, 533, 553, 654, 724, 824, 440, 540, 640, 740, 840, 940, 745S, 845S, 1255, 1255XL, 1455, 1455XL, 433, 533, 633, 644, 733, 743, 743XL, 744, 745XL, 833, 844, 844S, 844XL, 845, 856XL, 946, 955, 956, 955XL, 956XL, 1046, 1055, 1055XL, 1056, 1056XL, 1246	
25/149-7 (4661543)	JX55, JX60, JX65, JX70, JX75, JX80, JX85, JX90, JX95, JX1060C, JX1060V, JC1070C, JX1070N, JX1070V, JX1075C, JX1075N, JX1075V	
25/6050-1 (3132717R1)	323, 353, 383, 423, 433, 453, 533, 553, 654, 724, 824	
25/6050-2 (3218330R1, 3218257R1)	433, 533, 633, 644, 733, 743, 743XL, 744, 745XL, 833, 844, 844S, 844XL, 845, 856XL, 946, 955, 956, 955XL, 956XL, 1046, 1055, 1055XL, 1056, 1056XL, 1246	

TANKHÄHNE

Bestell-Nr.	Schleppertyp	OEM	Abb.
25/103-15	2120, 2130, 2140, 2150 + PRO PJ55, PJ65, PJ75, PJN55, PJN65, PJN75, PJV55, PJV65, PJV75	1967790C1	
25/103-16	AVJ55, AVJ60, AVJ70, VJ60, VJ70, VJ80	5176344	

Wir vertreiben keine Originalteile.
Die Nummern dienen lediglich als Beschreibung.



"THE RELIABLE SERVICE"



THERMOSTATE

Motoren IH

Thermostate	Abb.	Dichtung	Beschreibung	Schleppertyp
25/143-15 (3042303R92)	1	25/147-74 (3065125R1)	82°	B275, 276, 354, 374, 384, B414, 424, 434, 444 Motoren BD144, BD154
25/143-17 (3059676R91, 3059676R92, 3228046R2)	2	25/147-75 (3132143R1, 3132143R2)	82° Ø 54 mm	353, 385, 395, 423, 433, 440, 453, 454, 474, 484, 485, 533, 553, 584, 585, 633, 654, 674, 684, 685, 695, 724, 733, 743, 745, 784, 785, 795, 824, 833, 840, 844, 845, 856, 884, 885, 895, 940, 946, 956, 995, 1046, 1055, 1056, 1246, 1255, 1455, 3210, 3220, 3230, 4210, 4220, 4230, 4240

Motoren Cummins

Thermostate	Abb.	Dichtung	Beschreibung	Schleppertyp
25/143-44 (A77736, J906700, J912587)	3		Ø 54 mm Komplett mit Dichtung (J923331)	5120, 5130, 5140, 5150, 5220, 5230, 5240, 5250, MX100, MX110, MX120, MX135, MX150, MX170
25/143-70 x 2 (J907242, J928639)	4	25/147-70 (J914310)	82° - Ø 43.3 mm	7110, 7120, 7130, 7140, 7150, 7210, 7220, 7230, 7240, 7250, 8910, 8920, 8930, 8940, 8950, 9110, 9130, 9210, 9230, 9240, 9310, 9330, MX180, MX200, MX220
25/143-71 (J940632)	5	25/147-71 x 2 (238-5227)	82° - Ø 73 mm	MX210, MX230, MX240, MX255, MX270, MX285

Mähdrescher

25/143-70 x 2 (J907242, J928639)	4	25/147-70 (J914310)	82° - Ø 43.3 mm	1660, 1666, 1670, 1680, 1688, 2166, 2188 2365 (⇒ 177699), 2366 (⇒ 255699), 2388 (⇒ 290799) CF60, CF70, CF80
25/143-71 (J940632)	5	25/147-71 x 2 (238-5227)	82° - Ø 73 mm	2365 (177700 ⇒) 2366 (255700 ⇒) 2388 (290800 ⇒)

Motoren MWM

Thermostate	Abb.	Dichtung	Beschreibung	Schleppertyp
25/143-62 (130100061001, 130100061003)	6	25/147-62 (130100061002)	85°	C55, C55A, C64, C64A, C70A CS68, CS75, CS78, CS86, CS94 (⇒ 12/98)

Wir vertreiben keine Originalteile.
Die Nummern dienen lediglich als Beschreibung.

"THE RELIABLE SERVICE"
