

**HONDA**

**Power  
Equipment**

# Owner's Manual

## RT5000

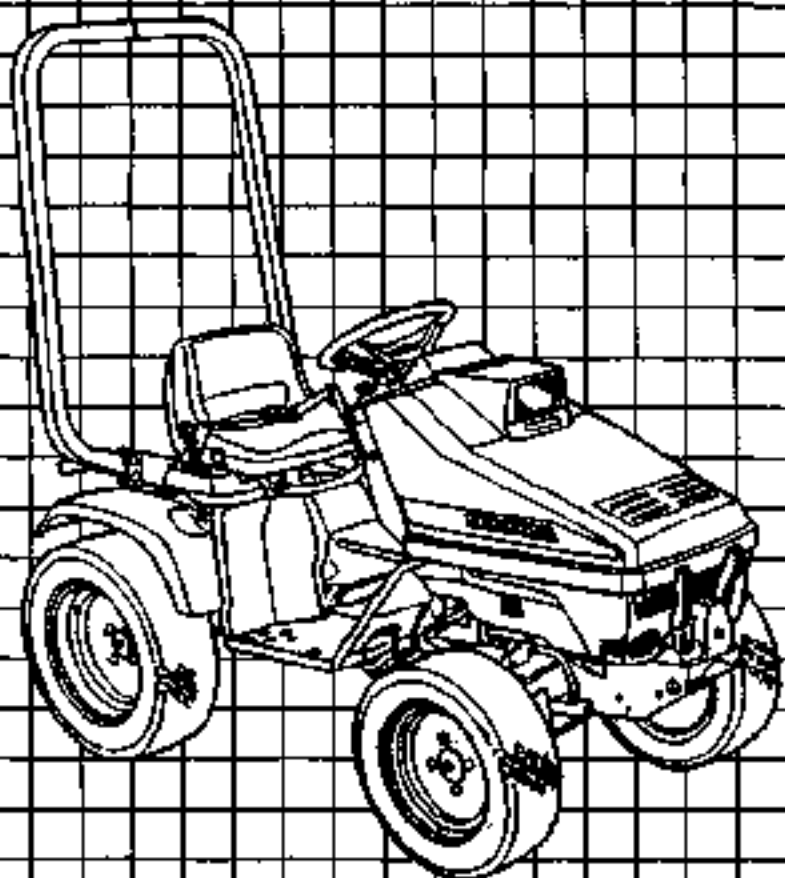

---

Thank you for purchasing a Honda Tractor.

This manual covers the operation and maintenance of the Honda RT5000 tractor.

Honda Motor Co., Ltd. reserves the right to make changes at any time without notice and without incurring any obligation.

No part of this publication may be reproduced without written permission.

This manual should be considered a permanent part of the tractor and should remain with the tractor when sold.

Pay special attention to statements preceded by the following words;

**⚠ DANGER:** Indicates severe personal injury or death will result if instructions are not followed.

**⚠ CAUTION:** Indicates a strong possibility of severe personal injury or death if instructions are not followed.

**CAUTION:** Indicates a possibility of personal injury or equipment damage if instructions are not followed.

**NOTE:** Gives helpful information.

If a problem should arise, or if you have any questions about your tractor, consult an authorized Honda Power Equipment dealer.  
Honda tractors are designed to give safe and dependable service if operated according to instructions.

**⚠ CAUTION:** Operating a tractor requires special effort to ensure the safety of the operator and the safety of others. Read and understand this Owner's Manual before operating the tractor: failure to do so could result in personal injury or equipment damage.

It is illegal in some areas to operate a gasoline engine without a U.S.D.A. qualified spark arrester; check local laws and regulations. You can purchase an optional spark arrester for this tractor from your authorized Honda Power Equipment dealer.

HONDA MOTOR CO., LTD. 1986, ALL RIGHTS RESERVED

# CONTENTS

---

1. SAFETY INSTRUCTION .....	4
Warning label location .....	4
Tractor safety .....	6
2. SERIAL NUMBERS .....	10
3. COMPONENT IDENTIFICATION .....	11
4. CONTROLS .....	13
INSTRUMENT PANEL .....	13
1. Engine switch .....	13
2. Headlight switch .....	14
3. Fuel gauge .....	14
4. Oil warning light .....	14
5. Parking brake warning buzzer .....	15
DRIVE COMPONENTS .....	16
1. Seat belt .....	16
2. Throttle lever .....	17
3. Choke knob .....	17
4. Brake pedal .....	18
5. Parking brake lock lever .....	18
6. Clutch pedal .....	19
7. Main Transmission lever/ Auxiliary Transmission lever .....	19
8. Front P.T.O. clutch lever .....	20
9. Rear P.T.O. lever .....	20
10. Rear P.T.O. shaft/shaft cover .....	21
11. Differential lock pedal .....	21
12. Hydraulic cylinder change lever .....	22
13. Hydraulic lift lever .....	23
14. Descent speed adjust knob .....	24
5. PRE-OPERATION CHECKS .....	25
1. Engine oil level .....	26
2. Air cleaner elements .....	27
3. Cooling shroud .....	27
4. Air intake screen .....	28
5. Battery electrolyte level .....	28
6. Fuel leakage .....	29
7. Hydraulic lift system oil leakage .....	29
8. Front P.T.O. belt .....	30
9. Front P.T.O. lever free play .....	30
10. Brake wear indicator .....	31
11. Brake pedal free play .....	31
12. Clutch pedal free play .....	32
13. Differential lock pedal free play .....	32
14. Tires/Wheels .....	33
15. Hydraulic lift system fluid .....	33
16. Seat position .....	34
17. Steering .....	34

18. Fuel level .....	35
19. Parking brake .....	37
20. Headlight .....	37
21. Safety interlock system .....	38
22. Hydraulic system .....	40
<b>6. OPERATION .....</b>	<b>41</b>
1. Starting the engine .....	41
2. Starting/Driving .....	43
3. How to use the differential lock .....	45
4. Turning .....	46
5. Attachment limitations .....	47
• Attachment limitations .....	47
▪ Towing .....	49
• Counterweights .....	50
6. Driving on a slope .....	52
7. Special obstacles .....	52
8. Stopping the engine .....	53
9. Recommended working speed .....	55
10. High altitude operation .....	56
<b>7. TRANSPORTING .....</b>	<b>67</b>
<b>8. INSTALLING AN ATTACHEMNT .....</b>	<b>58</b>
1. Rear 3 point hitch link installation (option) .....	58
2. Rear 3 point hitch attachment installation .....	59
<b>9. MAINTENANCE .....</b>	<b>61</b>
1. Toolkit .....	61
2. Maintenance schedule .....	62
3. Engine oil change .....	63
4. Air cleaner service .....	64
5. Spark plug service .....	65
6. Battery service .....	67
7. Fuel sediment cup cleaning .....	70
8. Transmission oil inspection .....	70
9. All fasteners tightness/lubrication points .....	71
10. Spark arrester maintenance .....	73
11. Wheel removal .....	74
12. Fuse replacement .....	75
13. Headlight bulb replacement .....	76
<b>10. STORAGE .....</b>	<b>77</b>
<b>11. WIRING DIAGRAM .....</b>	<b>79</b>
<b>12. TROUBLESHOOTING .....</b>	<b>80</b>
<b>13. SPECIFICATIONS .....</b>	<b>85</b>
<b>14. WARRANTY SERVICE .....</b>	<b>87</b>

# 1. SAFETY INSTRUCTIONS

## WARNING LABEL LOCATIONS

Read these WARNING LABELS before you operate the tractor!

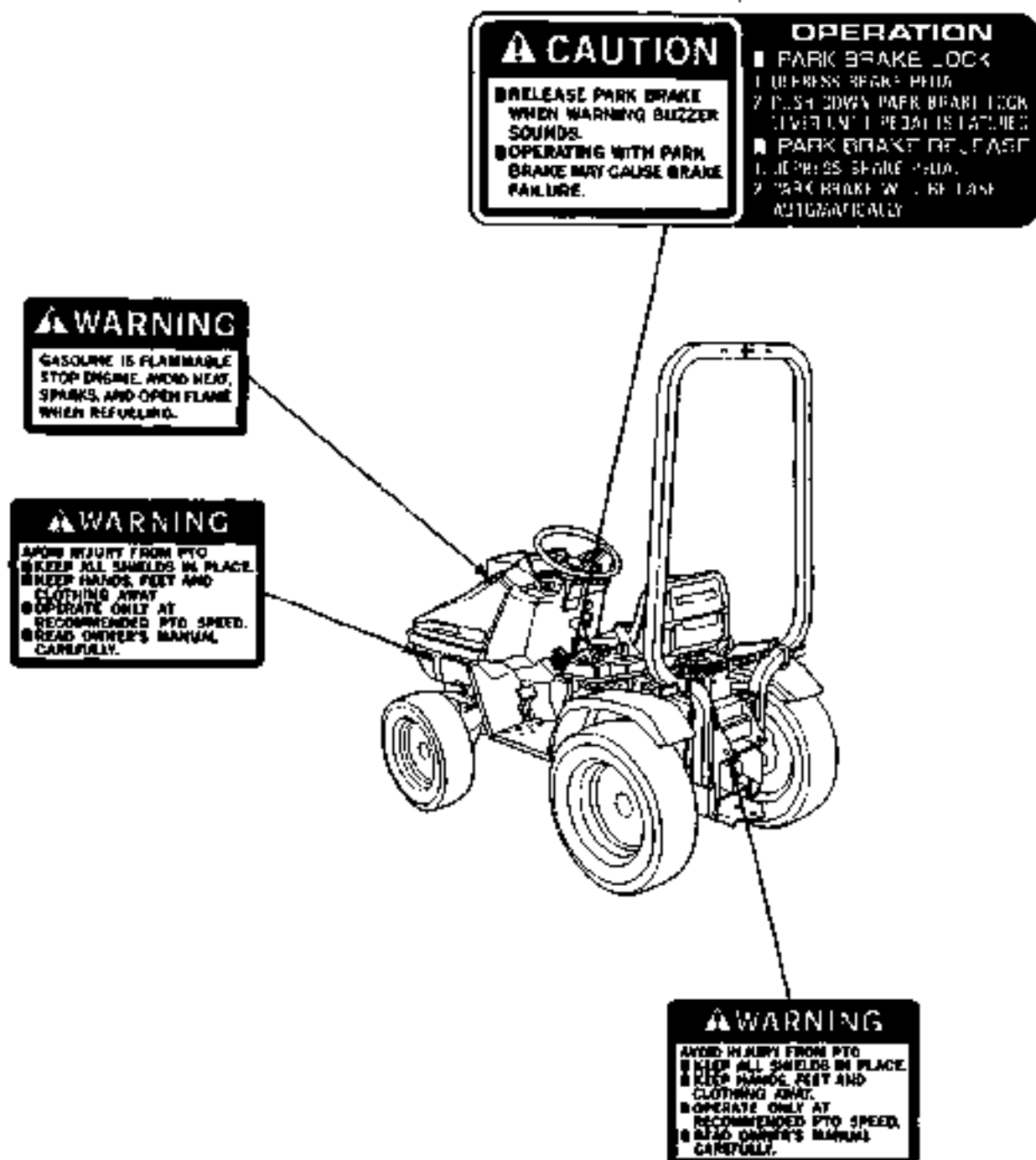

## ▲WARNING

- DO NOT OPERATE WITHOUT ROLLOVER PROTECTIVE STRUCTURE (ROPS).
- USE SEAT BELT PROPERLY. DO NOT USE SEAT BELT WITHOUT ROPS.

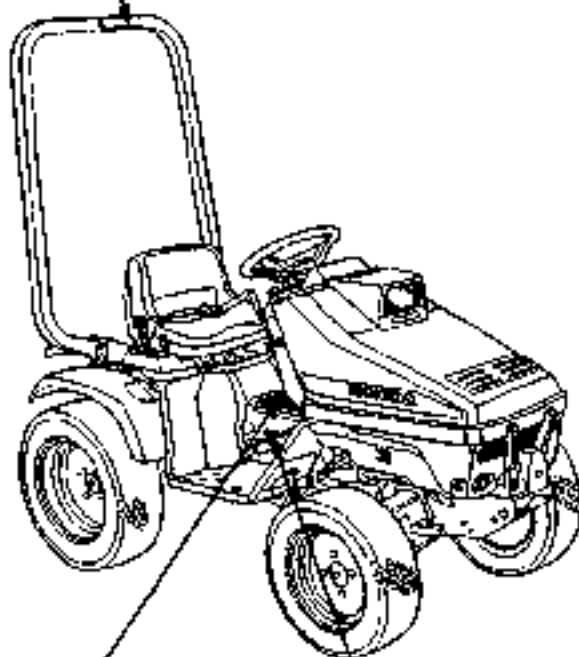

## ▲WARNING

- READ OWNER'S MANUAL BEFORE OPERATING.
- KNOW LOCATION AND FUNCTION OF ALL CONTROLS.
- EXHAUST GAS IS POISONOUS. DO NOT RUN ENGINE IN CONFINED AREA.
- OPERATOR ONLY. DO NOT CARRY PASSENGERS.
- KEEP ALL SHIELDS AND SAFETY DEVICES IN PLACE.
- KEEP PEOPLE AND PETS AWAY.
- WEAR PROTECTIVE CLOTHING AND SAFETY EQUIPMENT.
- THIS TRACTOR IS NOT LEGAL FOR USE ON PUBLIC STREETS OR HIGHWAYS.
- AVOID CURBS, STREETS, ROAD BRIDGES AND SWAMP TRENDS.
- REDUCE SPEED ON ROUGH TERRAIN AND SLOPES.
- DO NOT OPERATE WHERE MACHINE COULD TIP OR SLIP.
- LOOK BEHIND MACHINE BEFORE BACKING.
- DO NOT OPERATE WITHOUT ROLLOVER PROTECTIVE STRUCTURE (ROPS).
- USE SEAT BELT PROPERLY. DO NOT USE SEAT BELT WITHOUT ROPS.
- BE SURE MOVING PARTS AND ENGINE ARE STOPPED BEFORE MAKING ANY ADJUSTMENTS.
- LOCK BRAKE FOR PARK.
- REMOVE KEY BEFORE DISMOUNTING.

## OPERATION

### ▲DIFFERENTIAL LOCK

### ▲CAUTION

TO PREVENT STALLING, THIS IS CONTROLLED BY SPEED.  
Always engage differential lock at high speed.  
Disengage when with differential locked.  
Engage when differential lock on paved surfaces.  
Engage when differential lock on slippery or hills.

---

## TRACTOR SAFETY

**WARNING** Operation of the tractor and its attachments requires special efforts on your part to ensure your safety and the safety of others. Know these requirements before you operate the Tractor or its attachments:

### SAFE OPERATING RULES

- Severe personal injury or equipment damage may result if the pre-operation inspection (Page 25) is not performed before operating the tractor or its attachments.
- To avoid severe personal injury or equipment damage, observe the following precautions:
  - All parts, especially guards and shields, should be in good condition, and securely fastened in place.
  - Do not remove any guards, warning labels, shields or safety devices; they are installed for your safety.
  - The rollover protective structure (ROPS) will only help protect you from injury, if:
    - you are also wearing the seat belt.
    - the ROPS is securely attached and has not been modified or structurally damaged.
  - Always wear sturdy shoes and avoid wearing bulky or loose clothing while operating the tractor or its attachments.
  - Never operate the tractor or its attachments when tired or while under the influence of drugs or alcohol.
  - In case of emergency, know how to stop the engine and thoroughly understand the operation of ALL controls.
  - Never permit anyone to operate the tractor or its attachments without proper instructions.
  - Children should not be permitted to operate the tractor or any of its attachments.
  - **KEEP CHILDREN AND PETS AT A SAFE DISTANCE DURING OPERATION**
  - This is an operator only vehicle, do not allow passengers to ride on the tractor or on any of its attachments.
  - The exhaust contains poisonous carbon monoxide gas that can cause loss of consciousness and may lead to death, if the tractor is operated in an enclosed space.

---

## **BEFORE STARTING**

- **The use of heavy equipment and/or pulling excessive loads may adversely affect vehicle stability and control. To avoid loss of control that can result in severe personal injury:**
  - Only use recommended hitch attachment points.
  - Limit loads to as suggested on page 47.
  - Be extra careful when turning or backing up.
  - Use counterweight(s) as suggested on page 50.
- **Before installing or using any attachment, carefully read all instructions and precautions.**

## **OPERATION**

- **Be sure to fasten the seat belt whenever driving the tractor with the Rollover Protective Structure (ROPS) attached. Use of either device (seat belt or ROPS) without the other will increase the chance of injury in a rollover.**
- **Adjust the seat belt so that it is not slack.**
- **Be sure that the main Transmission lever is in "Neutral" the front and rear P.T.O. levers are in the "OFF" position before starting the engine.**
- **Operate the tractor and its attachments at low speed until you become familiar with all of its operating characteristics and controls.**
- **Do not operate the tractor or its attachments without ensuring the area in front and behind is clear of people and pets.**
- **Sudden stops of the tractor while driving at high speed or sudden start-up with the steering wheels turned fully in one direction, could cause the tractor to overturn.**
- **This tractor utilizes Four Wheel Steering (4WS) for a tighter turning circle and greater mobility than tractors with conventional steering. However, the feel of 4WS is slightly different from other tractors. Practice driving in a wide, safe area.**
- **Never operate the tractor or its attachments when visibility is diminished by darkness or bad weather; your ability to see obstacles will become impaired.**
- **Watch out for rocks, roots, holes and other obstacles that may cause the Tractor to overturn.**
- **This tractor and its attachments are intended for use on relatively flat terrain.**
- **It is illegal to operate this tractor on public streets, roads, or highways.**
- **When operating the tractor on a slope, always drive up and down the face of the grade. Turning or driving across the face of a slope may cause the tractor to overturn.**



- 
- To avoid loss of control or overturning, always reduce speed and exercise extreme caution when operating on sloping or uneven surfaces.
  - Attempting to change gears while operating the tractor on a slope may adversely affect vehicle stability and control and severe personal injury could result.
  - Do not back down, or rapidly accelerate up, a sloping surface.
  - To avoid loss of control or overturning, do not turn or stop on sloping surfaces.
  - When descending a slope, disengaging the clutch or shifting to neutral can cause a loss of control that may result in severe personal injury.
  - Do not operate the tractor near the edge of a ditch or an embankment, slipping off the edge could lead to severe personal injury and equipment damage.

To avoid injury to yourself and others, before leaving the Tractor unattended, ALWAYS,

- park on level ground.
  - disengage the power take-off.
  - lower the attachment(s).
  - shift into neutral.
  - Lock the parking brake.
  - stop the engine.
  - and remove the key.
- If you find it necessary to park on a grade, be sure to lock the parking brake and securely block the wheels.
  - Be sure to follow the instructions below whenever applying the differential lock.
    - Be sure that the main transmission lever is set in 4th gear or lower, and reduce engine speed before applying the differential lock.
    - Do not apply while turning the tractor.  
Use the lock only when driving straight ahead.
    - Do not rest your foot on the lock pedal while the lock is not in use.
    - Never apply while driving on a paved surface.

---

## **MAINTENANCE SAFETY**

- Before performing maintenance/inspection, read the instructions thoroughly.
- Before cleaning, inspecting or servicing the tractor, be sure to
  - Turn off and lower any attachments.
  - Stop the engine and remove the key.
  - Remove the spark plug cap.
- If you hit an object, stop the engine and inspect the Tractor and its attachments. Fix any damage before you resume operation.
- Operating the tractor with damaged, worn or broken parts may result in severe personal injury.
- Leaves, grass clippings, oil and other combustible materials can become a fire hazard. Be sure the body, engine and drive mechanism areas are kept clean.
- All nuts, bolts and fasteners must be tight.
- Do not change the engine governor settings or the engine may be damaged.

## **STORAGE SAFETY**

- To avoid the possibility of fire, allow the engine and exhaust system to cool before storing the tractor in an enclosed space or near combustible materials.
- When storing the tractor, be sure to apply the parking brake and remove the engine key.
- Drain all gasoline from the carburetor and fuel tank, and disconnect the battery ground cable.

## 2. SERIAL NUMBERS

---

The frame and engine serial numbers are used to identify your tractor and major attachments and may be required by the dealer when ordering replacement parts. The frame serial number is stamped on the right side of the frame. The engine serial number is stamped under the starter motor (inside the engine compartment).

Record the numbers here for your reference.

FRAME NO. \_\_\_\_\_

ENGINE NO. \_\_\_\_\_

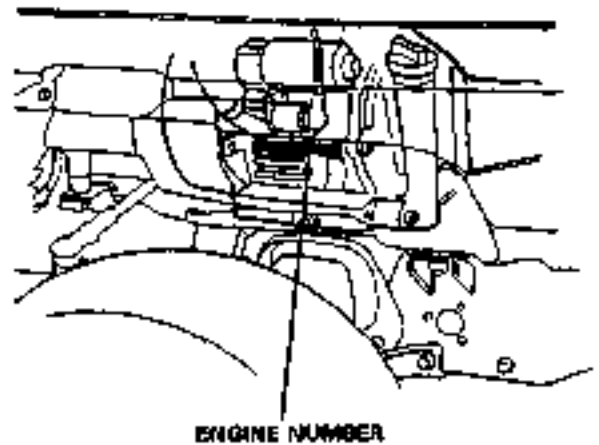
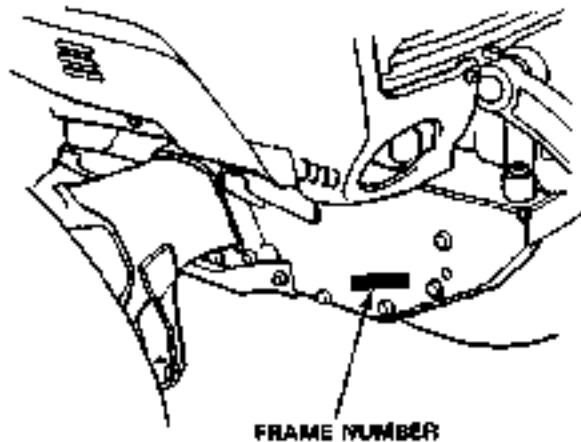

### 3. COMPONENT IDENTIFICATION

ROLLOVER PROTECTIVE STRUCTURE (ROPS)

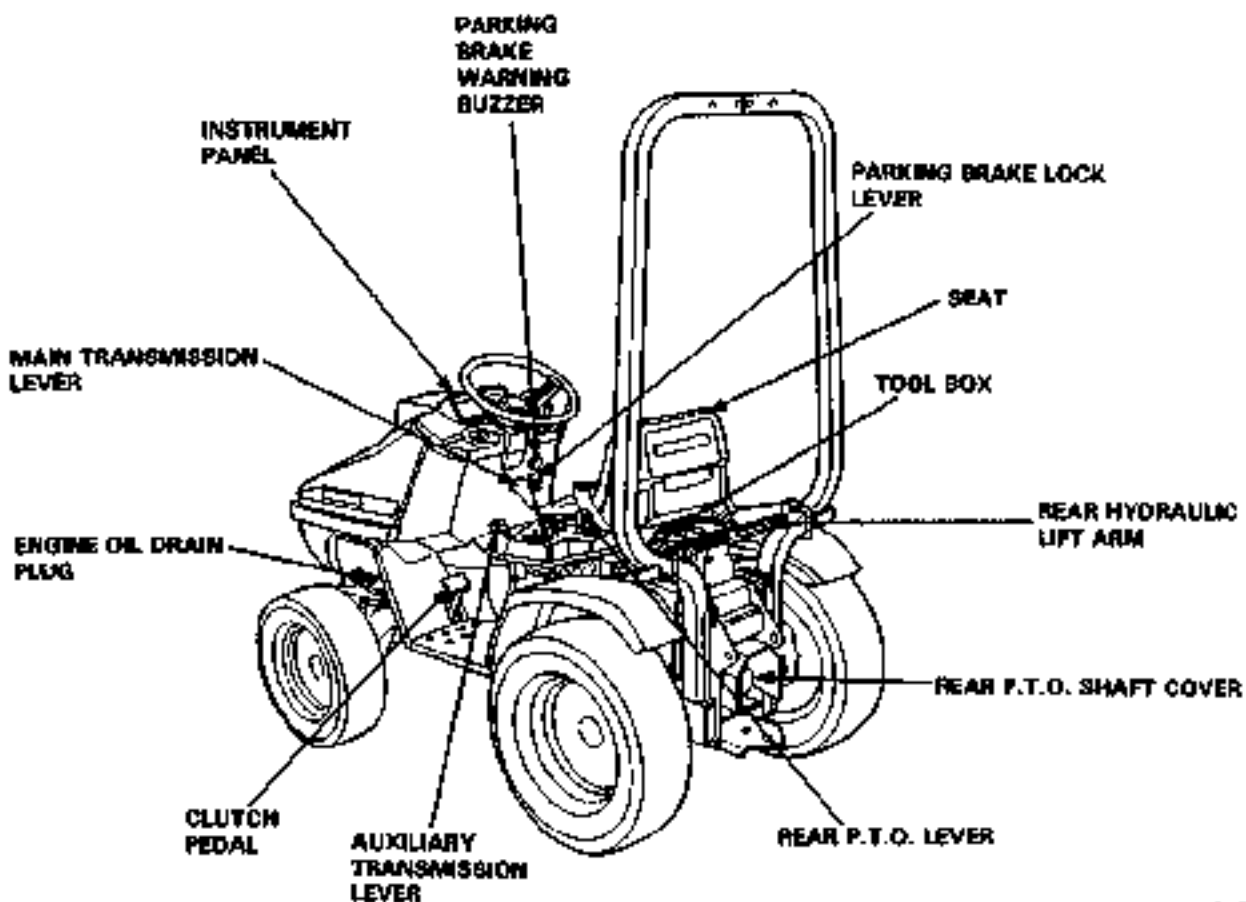
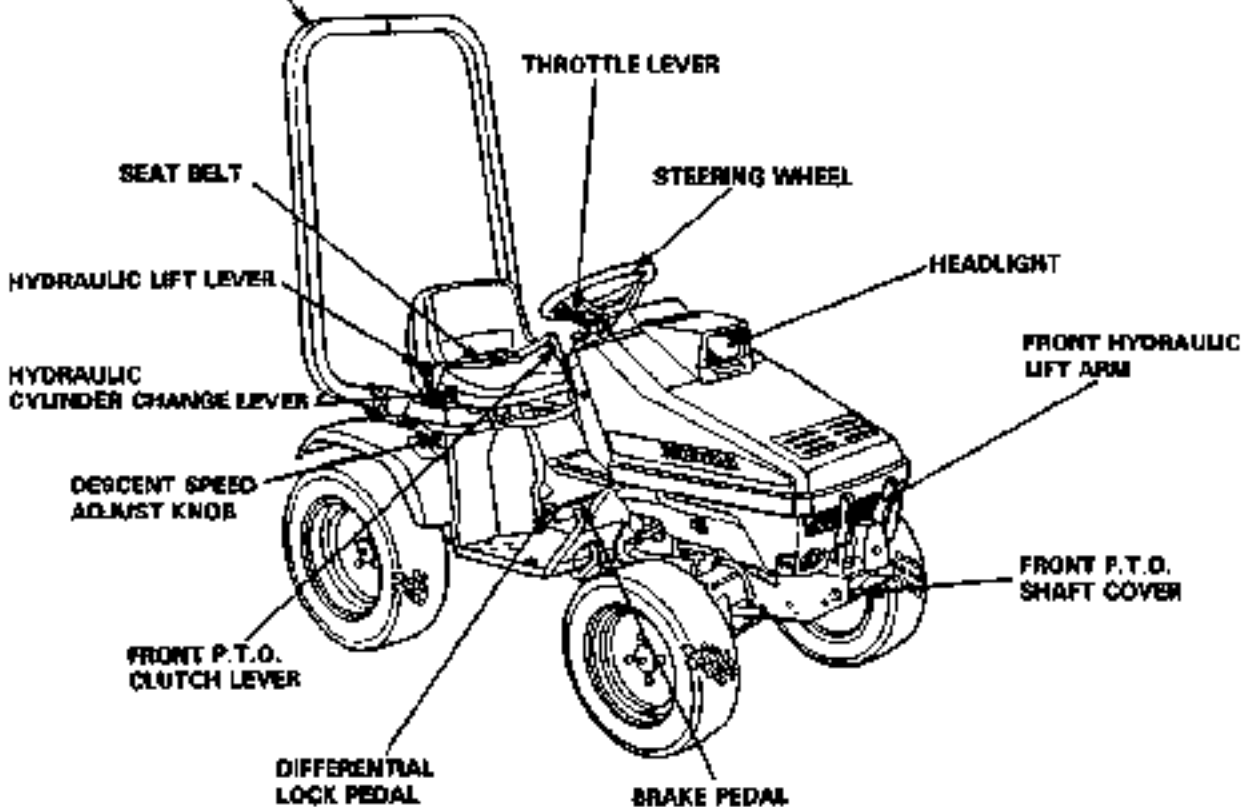

HYDRAULIC SYSTEM  
FLUID FILLER CAP

ENGINE HOOD

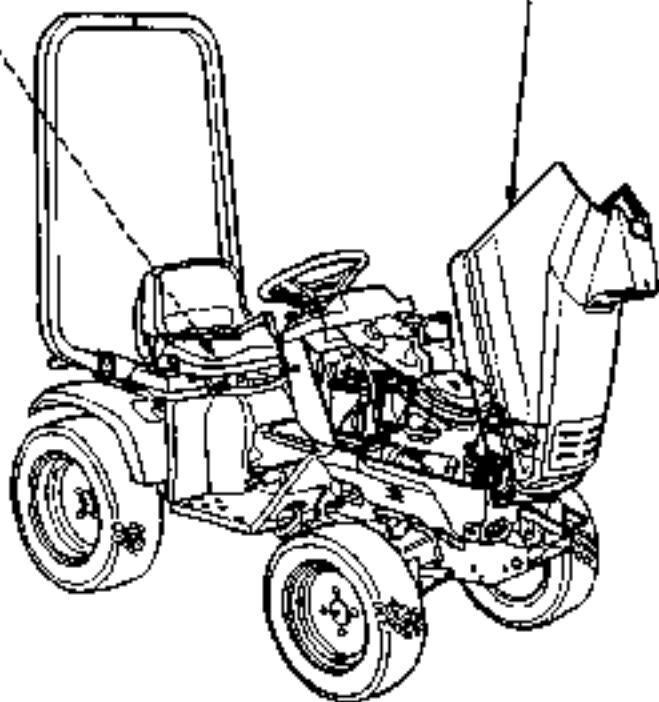

FUSE BOX

BATTERY

AIR INTAKE  
SCREEN

SPARK PLUG CAP

MAIN FUSE

AIR CLEANER

ENGINE OIL FILLER CAP

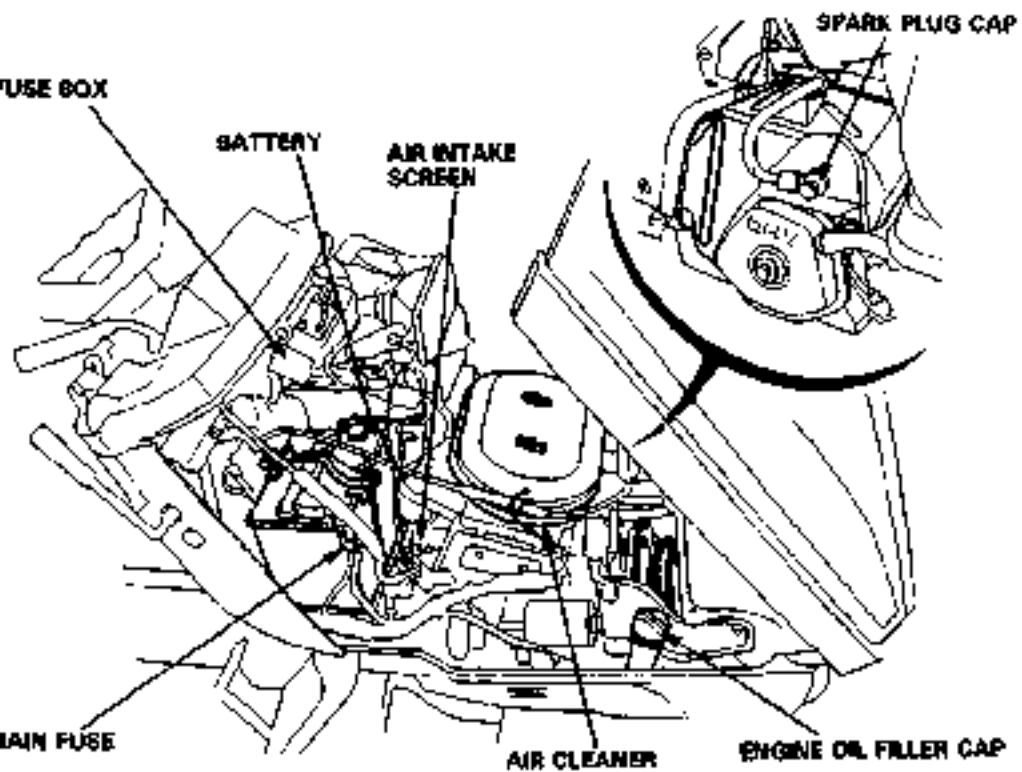

### INSTRUMENT PANEL

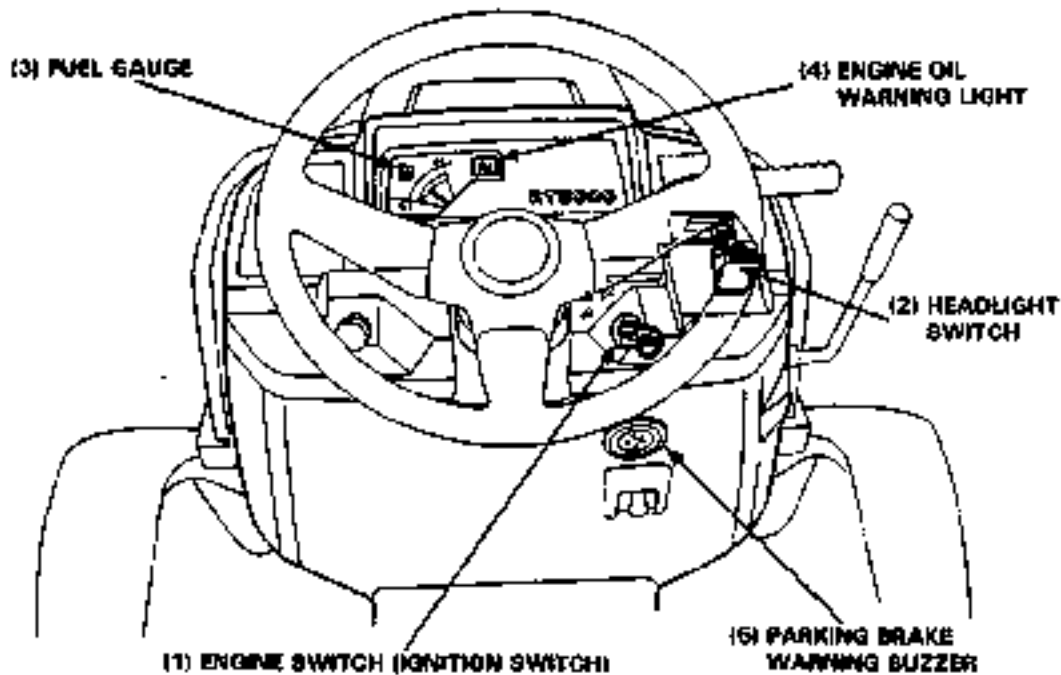

#### 1. Engine switch

**WARNING** Always remove the key from the engine switch whenever the tractor is unattended to prevent children or unauthorized persons from starting the engine.

This tractor is equipped with an automotive type engine switch, which controls all the electrical circuits.

Key positions: "START" to start the engine.

"ON" to run the engine after starting.

"OFF" to stop the engine (IGNITION OFF).

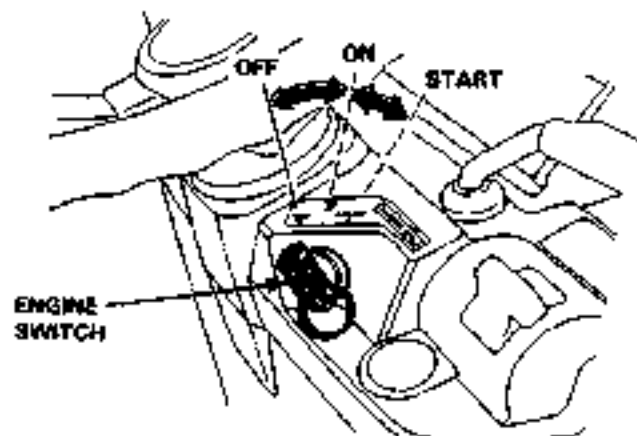

**NOTE:** The starter motor will not work unless the main transmission lever is in "N (Neutral)" the front and rear P.T.O. levers are in the "OFF" position.

---

## 2. Headlight switch

The switch turns the headlight ON or OFF.

**CAUTION:** To avoid discharging the battery, do not operate the headlight for prolonged periods with the engine in the SLOW position.

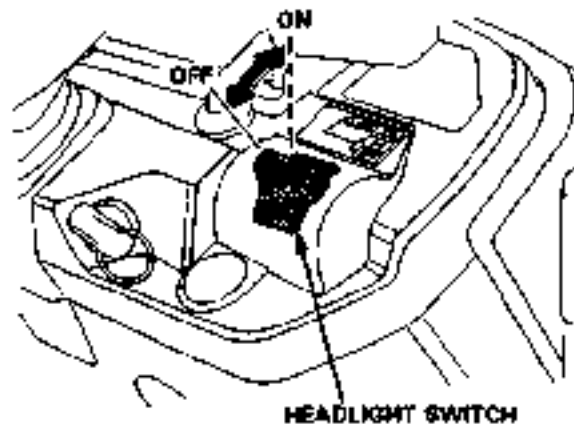

## 3. Fuel Gauge

The fuel gauge indicates the amount of fuel in the tank. It operates when the engine switch is in the ON position.

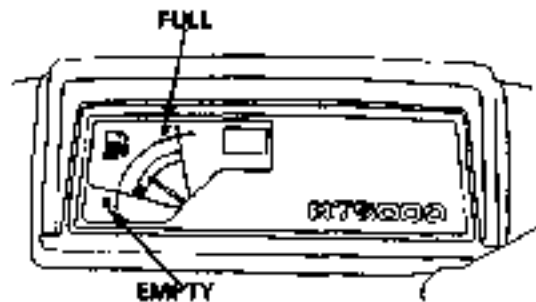

When the fuel gauge needle enters the "E" range, it indicates that the amount of remaining fuel in the tank is about 2.0 liters (0.5 gal). Refill as soon as possible.

#### 4. Engine Oil Warning Light

If the oil falls below normal operating level while the engine is running, the warning light will come on.

As a test, the oil warning should also light when the engine switch is ON and the engine is not running; once the engine is started, it should go out after a few seconds. If the warning light comes on while the engine is running, stop the engine immediately, check the engine oil level and add enough of the recommended oil to bring the level to the upper mark on the dipstick (See page 26).

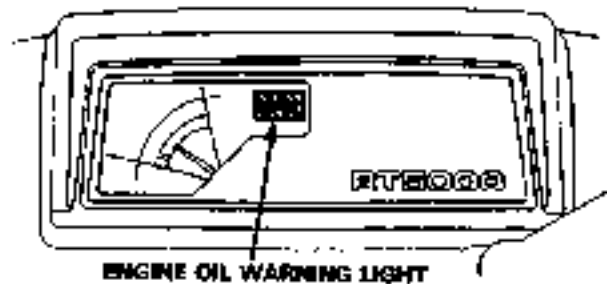

**CAUTION:** Running the engine with insufficient oil can cause serious engine damage.

#### 5. Parking Brake Warning Buzzer

There is a parking brake warning buzzer to remind you to release the parking brake lock before driving the tractor.

The warning buzzer will sound continuously if the transmission is shifted into gear while the parking brake is locked.



**WARNING** Operating the tractor with the parking brake locked will result in severe damage to the brake lining, and could lead to a complete brake system failure.



## DRIVE COMPONENTS

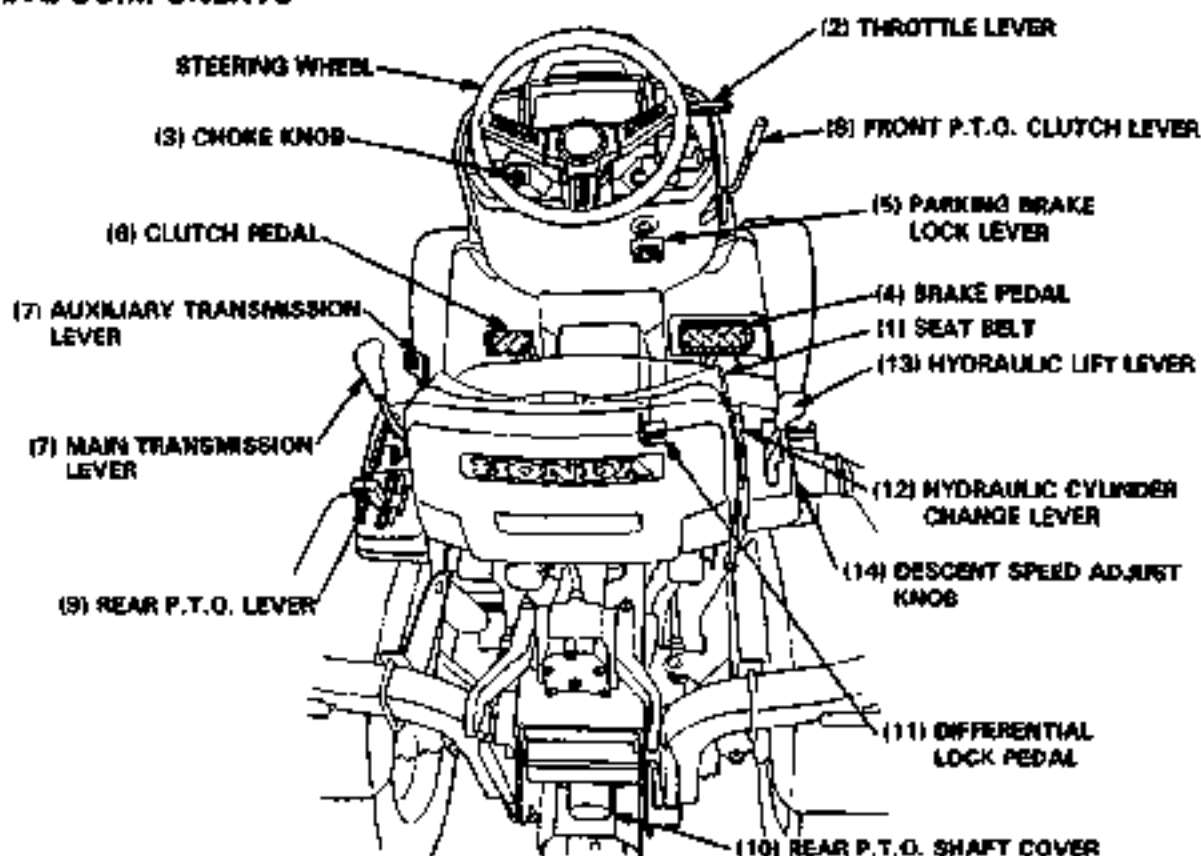

### 1. Seat Belt



- Wear the seat belt whenever operating the tractor with the Rollover Protective Structure attached.
- Use of either device (seat belt or ROPS) without the other will increase the chance of injury in a rollover.

Make sure that the seat belt is not twisted or kinked.

Push the tongue plate into the buckle until it clicks.

Sit erect and well back in the seat. Then adjust the belt to a snug fit by pulling out on the ends of the belt so the buckle is at the center of your body.

TONGUE PLATE

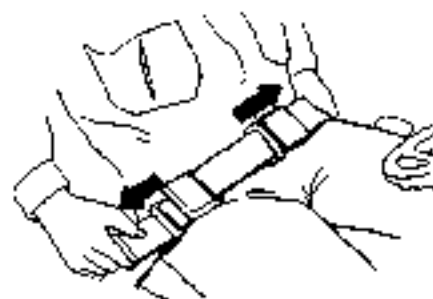
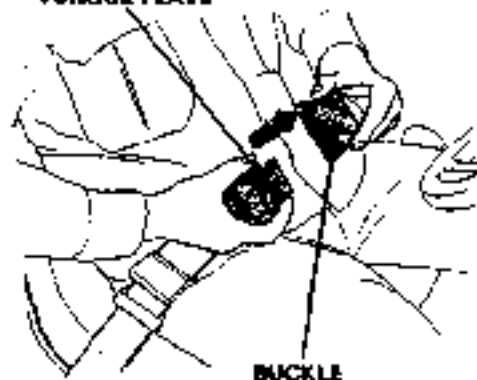

---

To release the seat belt, pull up on the buckle latch and pull out the tongue plate.

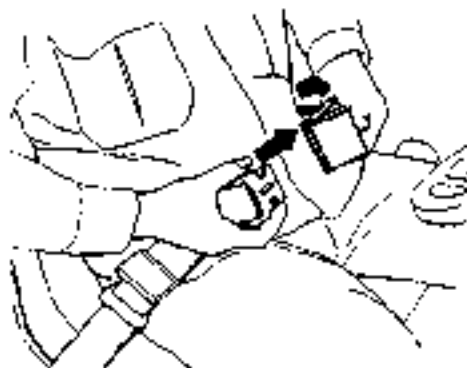

**Caution** Be sure that the belt is not twisted before fastening. The seat belt should be adjusted as firmly as possible to provide proper protection.

### 2. Throttle lever

The throttle lever controls engine speed from SLOW to FAST; it will stay in any designated position.

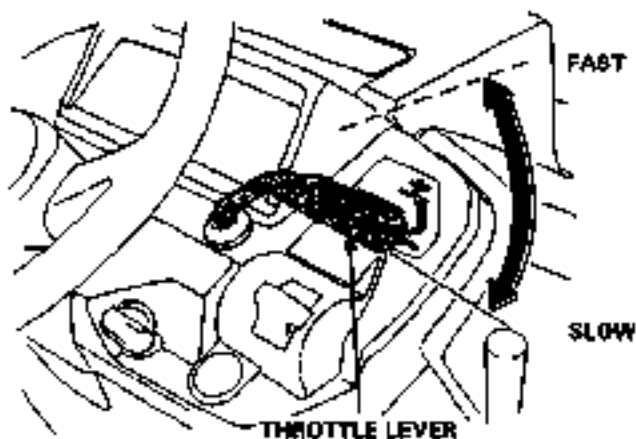

### 3. Choke Knob

Operate the choke knob when the engine is cold.

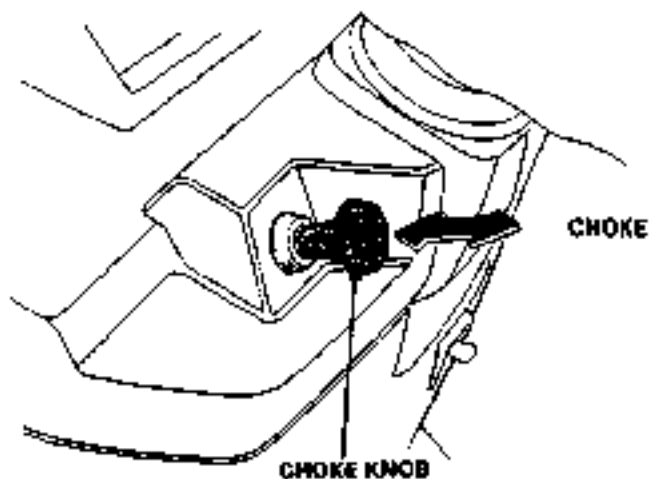

#### 4. Brake Pedal

The brake pedal is used to slow the tractor.

When you want to bring the tractor to a full stop, be sure to depress the clutch pedal first, then the brake pedal. This is particularly important when you are driving in 1st to 4th gear, as greater torque is transmitted to the driving wheels in these speed ranges.

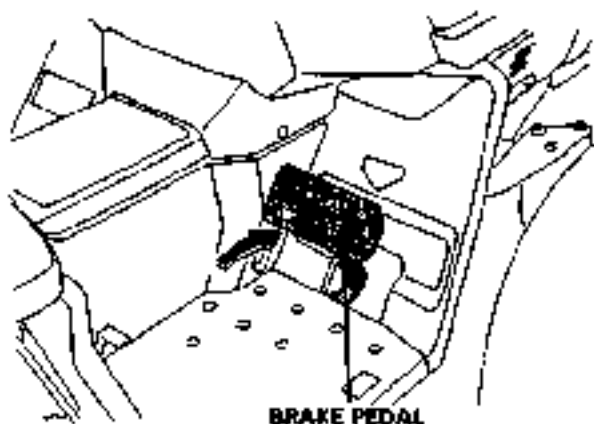

**CAUTION:** Depressing the brake pedal hard while the tractor is being driven in the 1st to 4th ranges may cause damage to the tractor drive components unless the clutch pedal is depressed.

#### 5. Parking brake lock lever

The parking brake lock lever is used when the tractor is stopped.

1. Firmly depress and hold the brake pedal.
2. Push and hold the parking brake lock lever.
3. Release the brake pedal and then release the parking brake lock lever.
4. To release the parking brake, push the brake pedal once.

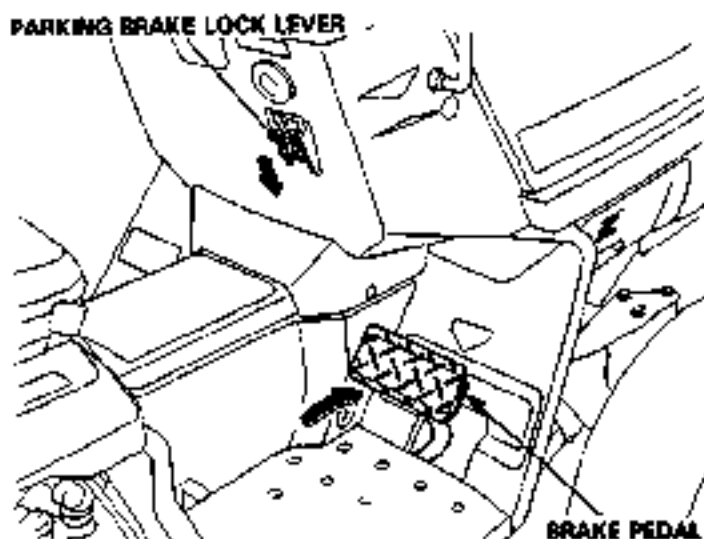

**WARNING:** Operating the tractor with the parking brake locked will result in severe damage to the brake lining, and could lead to a complete brake system failure.

## 6. Clutch Pedal

Depress the clutch pedal when operating the main transmission lever, auxiliary transmission lever, or the rear P.T.O. lever.

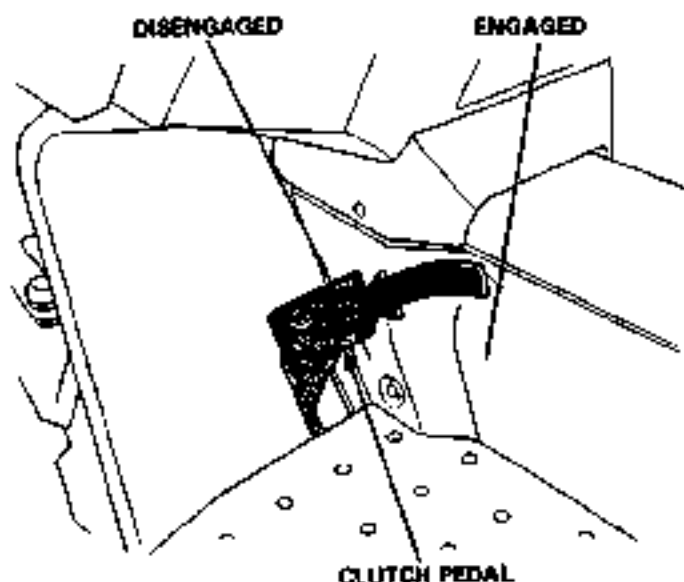

## 7. Main Transmission lever/Auxiliary Transmission lever

Eight forward and four reverse speeds can be selected by shifting the main and auxiliary transmission levers. For each slotted position of the main transmission lever, one of two speeds can be selected by either moving the auxiliary lever up (higher position) or down (lower position).

[HIGH GEAR POSITION]



[LOW GEAR POSITION]

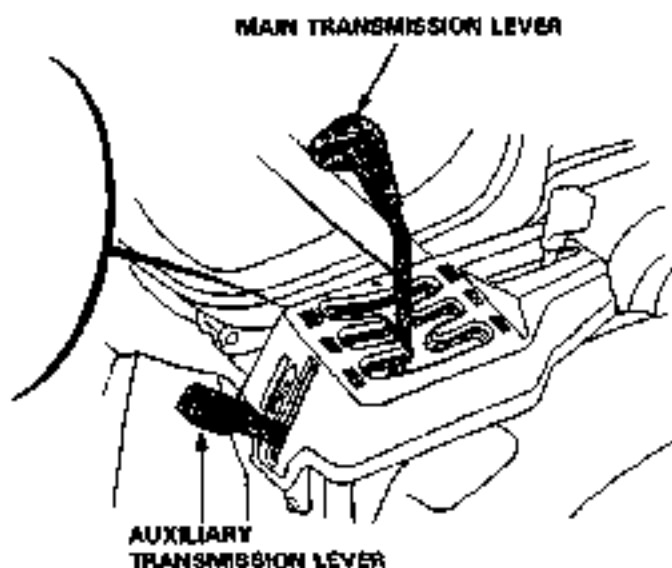
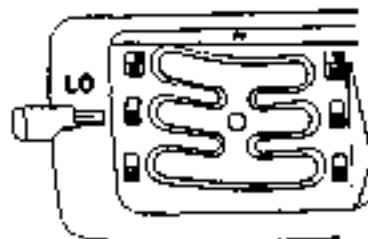

### CAUTION

- Be sure to depress the clutch pedal first, before moving the shift levers.
- Do not operate the transmission lever while the tractor is moving.

## 8. Front P.T.O. clutch lever

The lever is used to engage or disengage the front P.T.O. (Power Take Off) shaft.  
Lever in "ON" position—P.T.O. shaft rotates  
Lever in "OFF" position—P.T.O. shaft stops

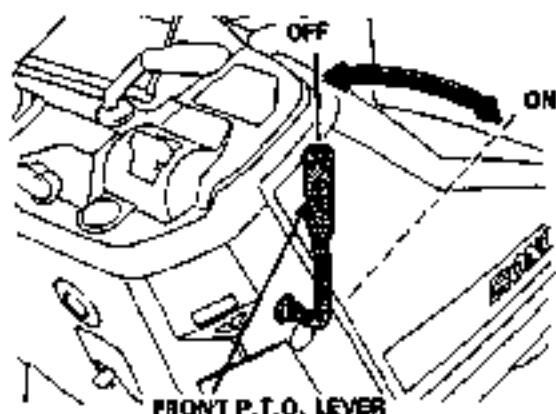

**NOTE:** When starting the engine, the front P.T.O. clutch lever must be in the "OFF" position or the starter motor will not run.

## 9. Rear P.T.O. lever

The lever is used to engage or disengage the rear P.T.O. shaft.  
The rear P.T.O. shaft rotates when the rear P.T.O. lever is set in the "ON" position and the clutch pedal is released.  
Lever in "ON" position and clutch engaged—P.T.O. shaft rotates.  
Lever in "ON" position and clutch pedal is depressed—P.T.O. shaft disengaged.  
Lever in "OFF" position—P.T.O. shaft disengaged.

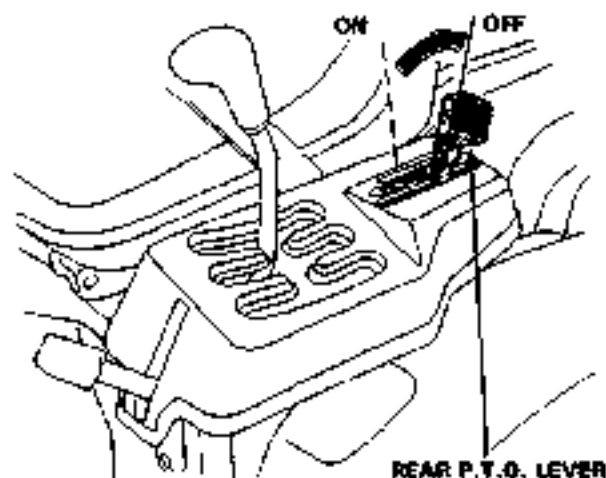

**CAUTION:** Before operating the P.T.O. lever, completely stop the tractor and depress the clutch pedal.

**NOTE:** When starting the engine, the rear P.T.O. lever must be in the "OFF" position or the starter motor will not run.

## 10. Rear P.T.O. shaft/shaft cover

The rear P.T.O. shaft is a coupling device which is used to transmit power from the engine to an attachment installed at the rear of the tractor.

Install the cover over the shaft whenever the rear P.T.O. shaft is not used.

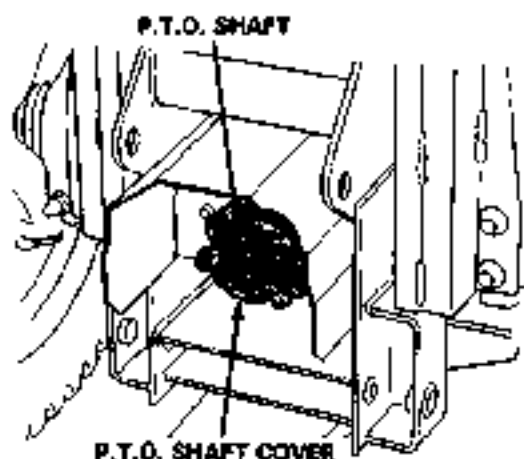

**WARNING** Operating the tractor without installing the cover over the shaft is very hazardous because clothing or other articles may be caught on the rotating shaft.

## 11. Differential lock pedal

When greater straight-line traction is desired on loose or soft terrain, pushing and holding the pedal locks the differential causing the rear wheels to rotate at the same speed. For normal operation, the pedal should be released (unlocked) so that the differential allows one rear wheel to rotate at a different speed than the other around curves.

To release the lock remove your foot from the pedal.

For operation of the differential lock, refer to Page 45.

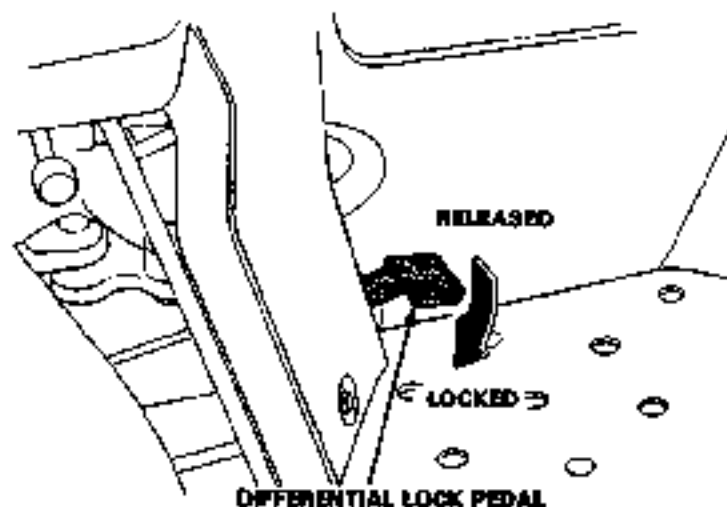

## HYDRAULIC LIFT SYSTEM

The front and rear attachments can be lifted and lowered by operating the hydraulic cylinder change lever and hydraulic lift lever, when the engine is running, regardless of whether the clutch is engaged or not.

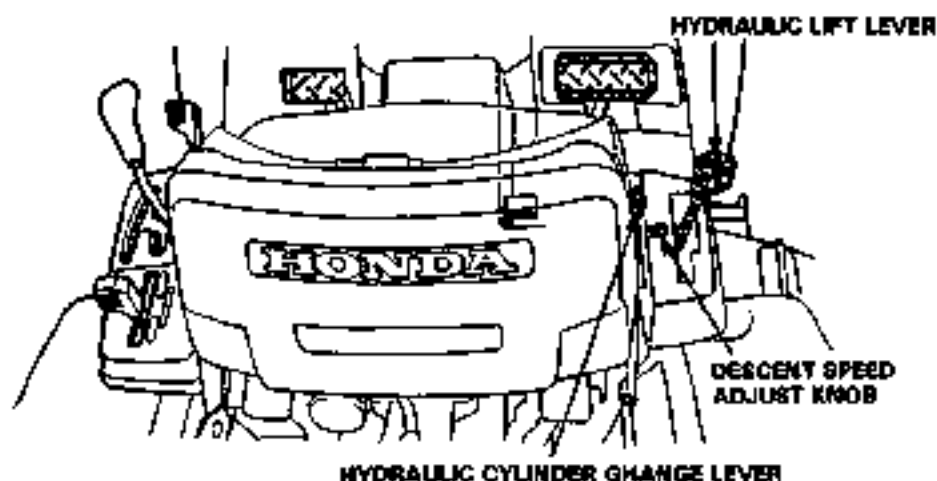

### 12. Hydraulic cylinder change lever

The oil pressure from the oil pump can be changed to either the front or rear hydraulic system by operating this lever.

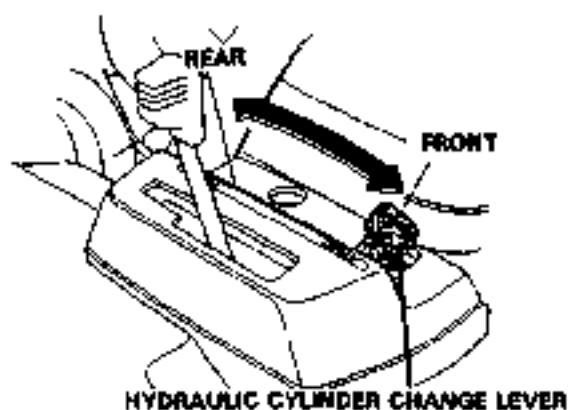

**CAUTION:** Always shift the lever fully into the Front or Rear position. Leaving the lever halfway between these two positions may damage the hydraulic system or interfere with its normal operation.

Observe the following when operating the hydraulic cylinder change lever:

- 1. To prevent lowering of attachment, turn the descent speed adjust knob clockwise fully to SLOW.
- 2. Place the lift lever in the DOWN position.
- 3. Place the change lever in the FRONT or REAR position.
- 4. Turn the descent speed adjust knob out as necessary to obtain the desired speed.

### 13. Hydraulic lift lever

The attachment can be raised and lowered by operating this lever. In the SLOW UP position, the attachment will lift slowly and in the FAST UP position, the attachment will lift quickly. In the SLOW DOWN position the attachment will lower slowly and in the FAST DOWN position the attachment will lower more quickly. In either DOWN setting, the attachment will be lowered even though the engine is stopped. The attachment will be stopped at its applied position when the lever is set in NEUTRAL.

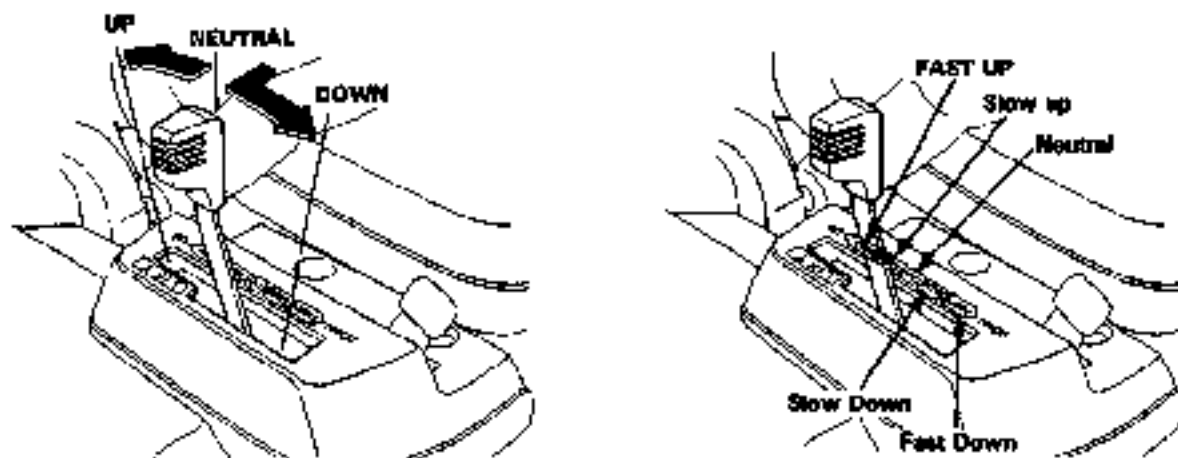

**CAUTION:** Do not hold the lift lever in the FAST UP or SLOW UP position after shifting. Holding the lever in these positions with force can lead to a bent lever or some sort of malfunction in the hydraulic system.

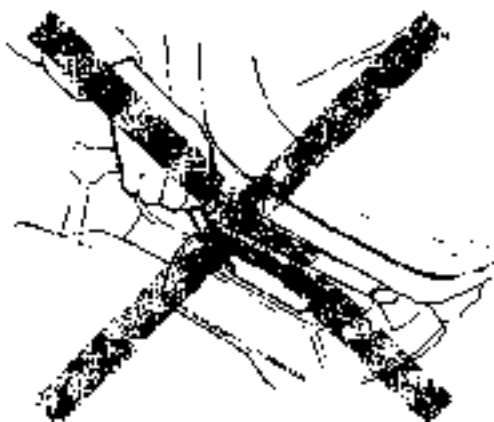



---

#### 14. Descent speed adjust knob

Descending speed can be pre-adjusted to compensate for the weight of the attachment. Adjust the knob so that an attachment will be lowered to the ground from its highest position within 1-2 seconds with the lift lever in the FAST DOWN position. Thus, lighter attachments may require more FAST pre-adjustment and heavier attachments may require more SLOW pre-adjustment. However, too much or too little pre-adjustment will limit the operating speed range selectable by the lift lever.

Before adjusting the descending speed, it is necessary to set the lift lever in NEUTRAL.

Turning the knob clockwise toward SLOW will decrease the speed, and turning it counterclockwise toward FAST will increase the speed. The attachment will not be lowered when this knob is turned fully to SLOW.

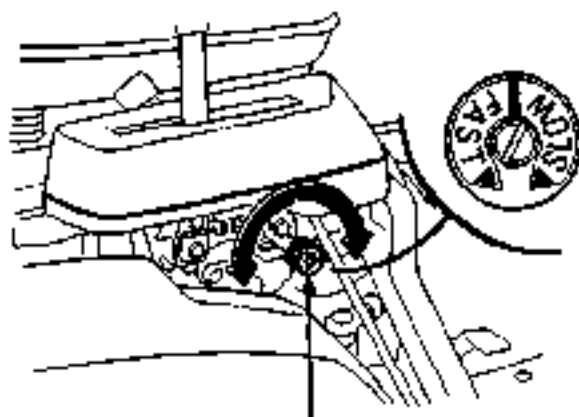

DESCENT SPEED ADJUST KNOB

#### CAUTION:

- Before performing any inspection or adjustment pay particular attention to your safety as well as the safety of others.
- To adjust speed, always turn the adjusting knob in increments of 1/4 turn.
- Lower the attachment and set the lift lever in NEUTRAL before adjusting descent speed.
- Do not overtighten the descent speed adjust knob.

## 5. PRE-OPERATION CHECKS

For safe and efficient operation, always perform the pre-operation checks before using the tractor.

**WARNING** To prevent accidental start-up, remove the engine switch key, and disconnect the spark plug cap before performing the pre-operation inspection.

### CAUTION:

- Inspect with the tractor on level ground.
- Lock the parking brake, set the transmission lever in "N" (Neutral) and the front and rear P.T.O. levers in the "OFF" positions.

### OPENING/CLOSING THE HOOD

- To open, pull up at the grip area until the hood support rod stops at the fully open position.
- To close, release the support rod by pulling the hood up slightly, then slowly lower the hood.

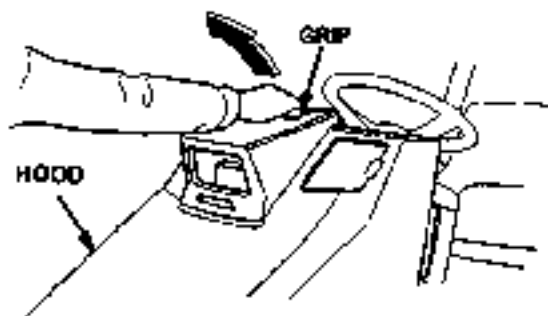

## 1. Engine oil level

### CAUTION:

- Engine oil is a major factor affecting engine performance and service life. Non-detergent oil and 2-stroke engine oil are not recommended.
- Running the engine with insufficient oil can cause serious engine damage.

- Place the tractor on a level surface.
- Open the hood, remove the oil filler cap and wipe the dipstick clean.
- Insert the dipstick into the oil filler neck, but do not screw it in.
- Check the oil level shown on the dipstick. If near or below the lower level mark, fill to the upper level mark with the recommended oil.
- Install the oil filler cap securely.

Use Honda 4-stroke oil, or an equivalent high detergent, premium quality motor oil certified to meet or exceed U.S. automobile manufacturers' requirements for service classification SE or SF (Motor oils classified SE or SF will show this designation on the container).

SAE 10W-40 is recommended for general use.

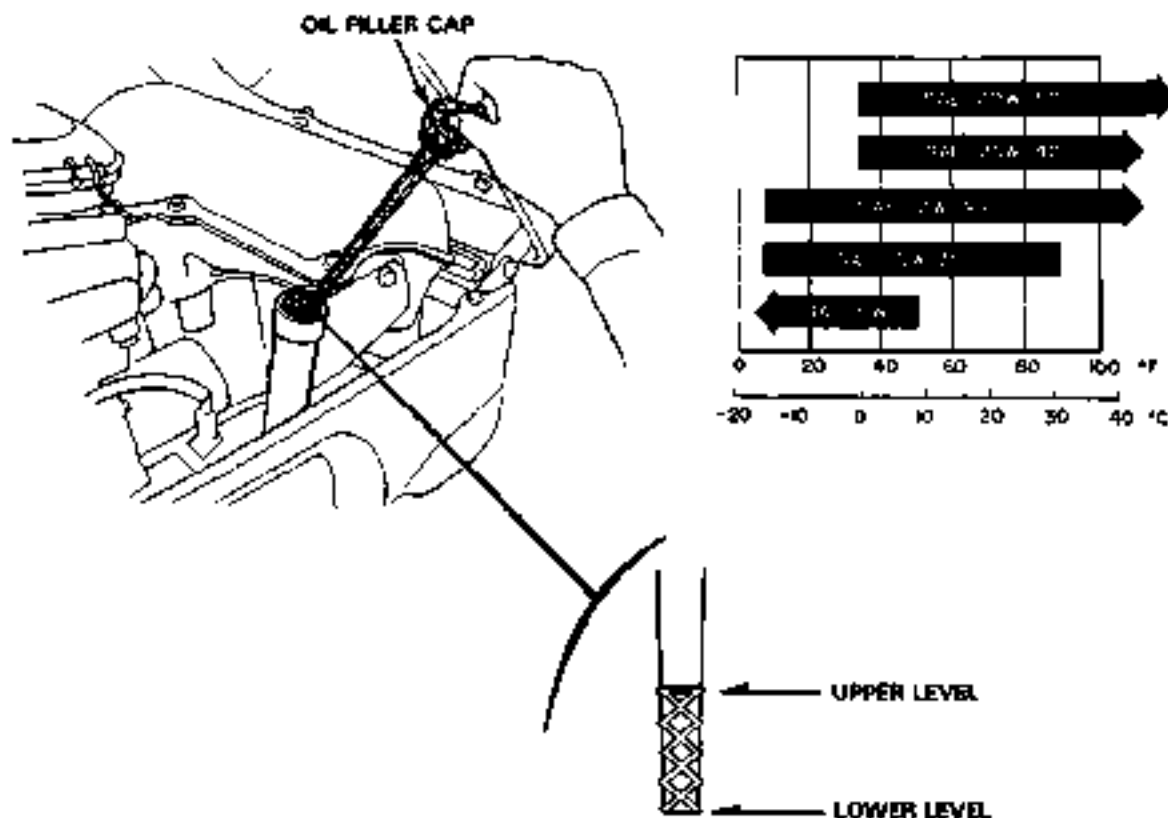

---

## 2. Air cleaner elements

1. Remove the wing nuts to remove the air cleaner cover.
2. Remove the air cleaner elements.

If the elements are dirty, follow the cleaning procedure described on page 64.

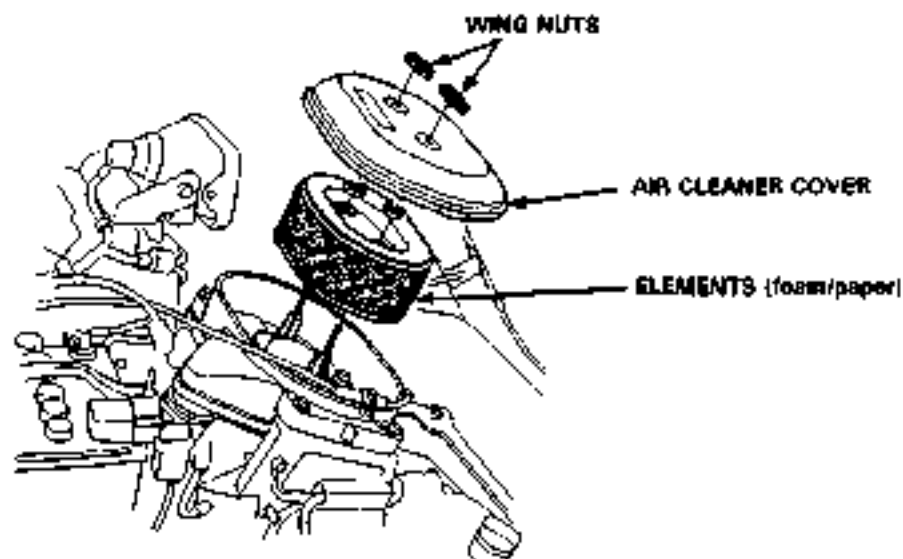

**CAUTION:** If the air cleaner cover and/or elements are not installed or are installed improperly, dirt may enter and damage the engine.

## 3. Cooling shroud

Remove the spark plug cap and clean any dirt from the shroud.

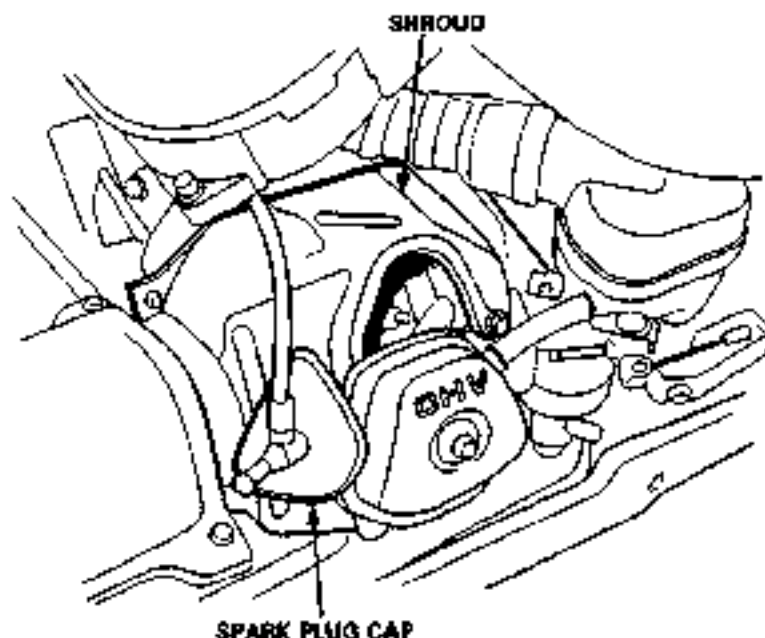

#### 4. Air intake screen.

Remove any debris from the screen grid.

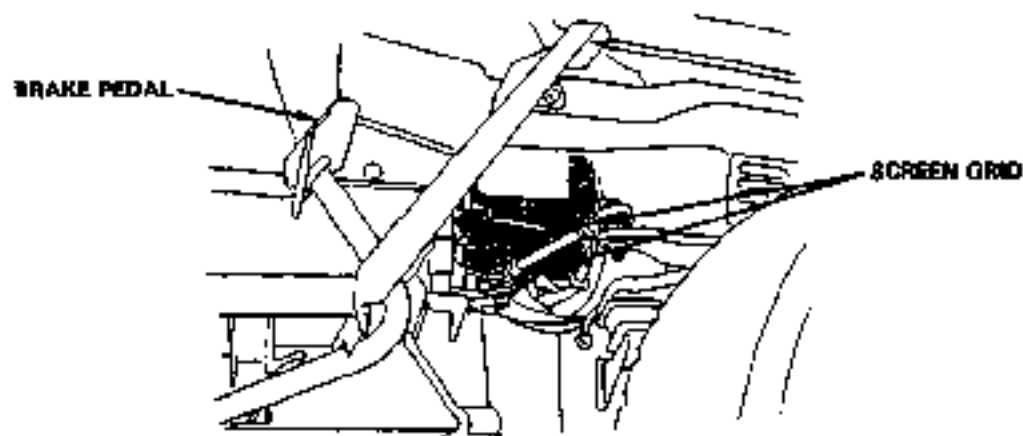

#### 5. Battery electrolyte level

Check that the battery electrolyte level in each cell is in between the UPPER and LOWER level lines. Fill the battery with distilled water if the level is low (see p. 67).

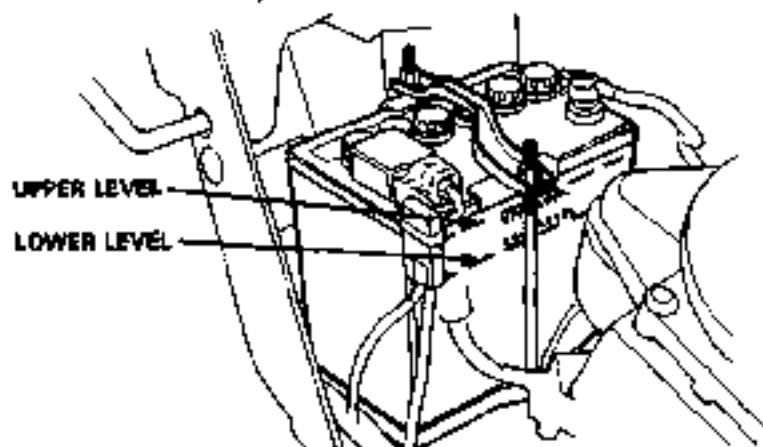

#### ⚠️ Warnings

- The battery gives off explosive gases; keep sparks, flames and cigarettes away. Provide adequate ventilation when charging or using batteries in an enclosed space.
- The battery contains sulfuric acid (electrolyte). Contact with skin or eyes may cause severe burns. Wear protective clothing and a face shield.
  - If electrolyte gets on your skin, flush with water.
  - If electrolyte gets in your eyes, flush with water for at least 15 minutes and call a physician immediately.
- Electrolyte is poisonous.
  - If swallowed, drink large quantities of water or milk and follow with milk of magnesia or vegetable oil and call a physician.
- **KEEP OUT OF REACH OF CHILDREN.**

#### CAUTION:

- Use only distilled water in the battery. Tap water will shorten the service life of the battery.
- Filling the battery above the UPPER LEVEL line may cause the electrolyte to overflow, resulting in corrosion to engine or nearby parts. Immediately wash off any spilled electrolyte.

---

## 6. Fuel leakage

Visually inspect the fuel line for cracks or fuel leakage. If there is any sign of cracks or fuel leakage, contact your authorized Honda tractor dealer to have it repaired.

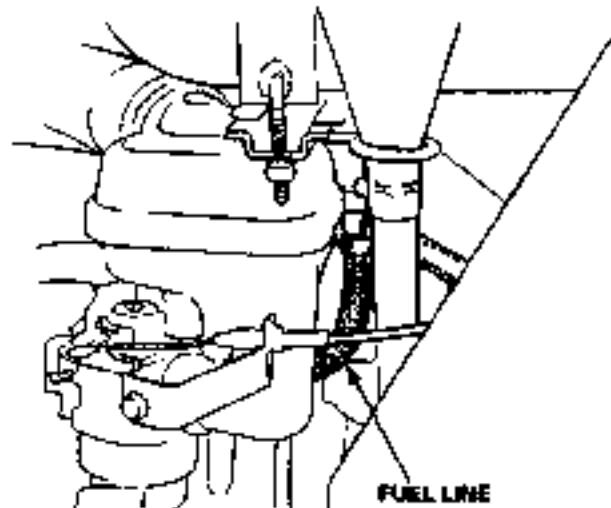

## 7. Hydraulic lift system oil leakage

Open the hood, raise the seat, and visually inspect the oil line for cracks or oil leakage. If there is any sign of cracks or oil leakage, contact your authorized Honda tractor dealer to have it repaired.

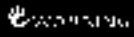
 Escaping hydraulic fluid under pressure can penetrate the skin causing serious injury. Avoid checking the oil lines while the engine is running as it is very hazardous.

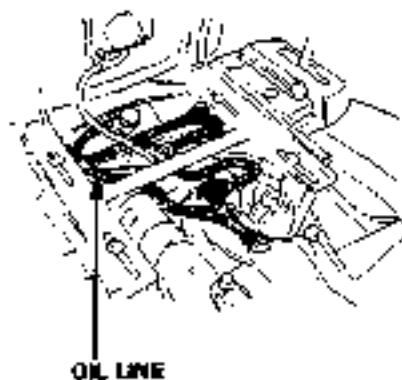
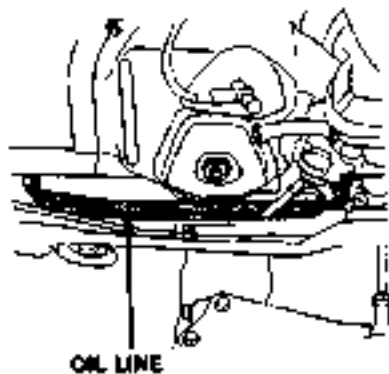

## 8. Front P.T.O. belt

Visually inspect the front P.T.O. belt for wear or damage. If worn or damaged, contact your authorized Honda tractor dealer to have it serviced.

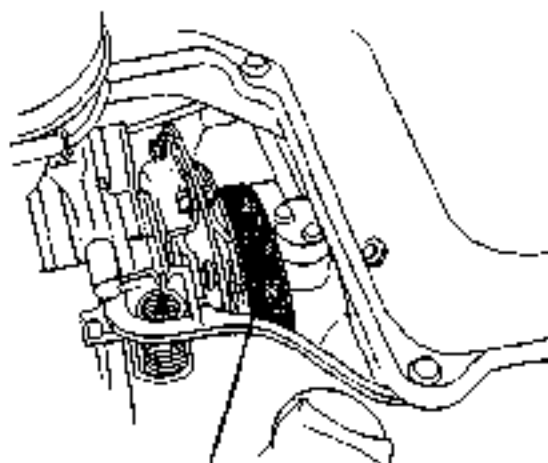

FRONT P.T.O. BELT

## 9. Front P.T.O. lever free play

Move the lever with your fingers and check that the free play at the tip of the lever is 1.0–3.0 mm (0.04–0.12 in).

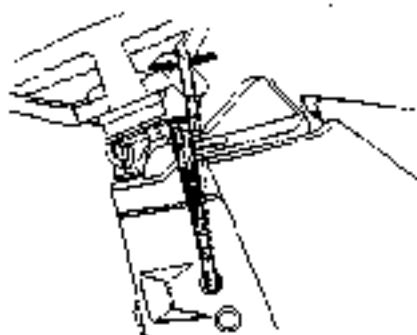

If the free play is out of specification, loosen the cable lock nut and turn the adjusting nut until the correct free play is obtained.

**CAUTION:** The clutch cannot be disengaged if the front P.T.O. lever has no free play.

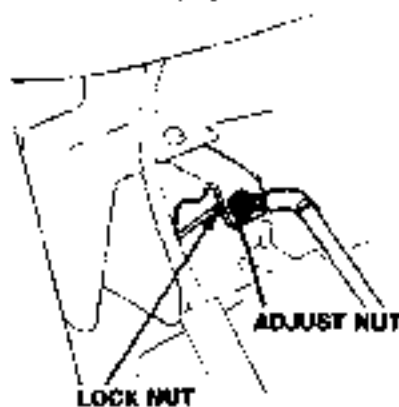

## 10. Brake wear indicator

The condition of the brake linings can be checked by inspecting the fitting on the end of the brake rod. If you can see the wear indicator through the right axle tube flange when the brake pedal is fully depressed, consult your authorized Honda tractor dealer.

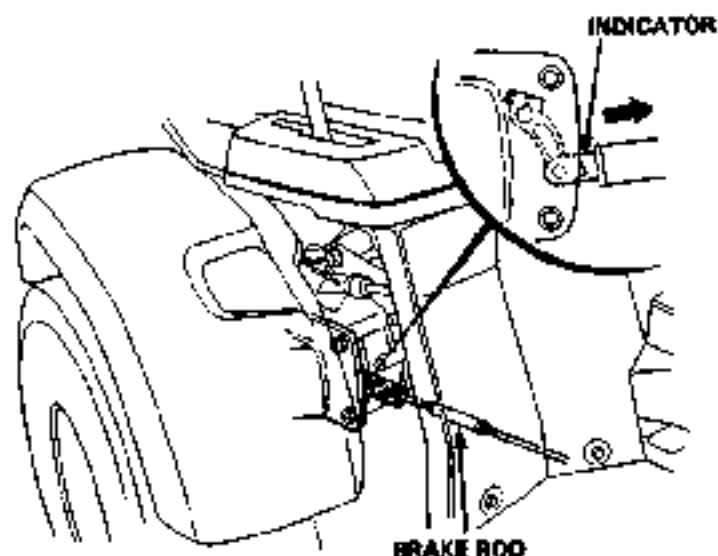

**CAUTION:** Do not operate the tractor with worn-out brakes. If any part of the wear indicator reaches its limit mark, the brake system does not have its full capability and requires service.

## 11. Brake pedal free play

Measure the brake pedal free play from fully released to the point you can feel the brake begin to take hold. Free play should be 15–35 mm (0.6–1.4 in). Consult your authorized Honda tractor dealer if free play is out of specification, or the brake does not operate properly.

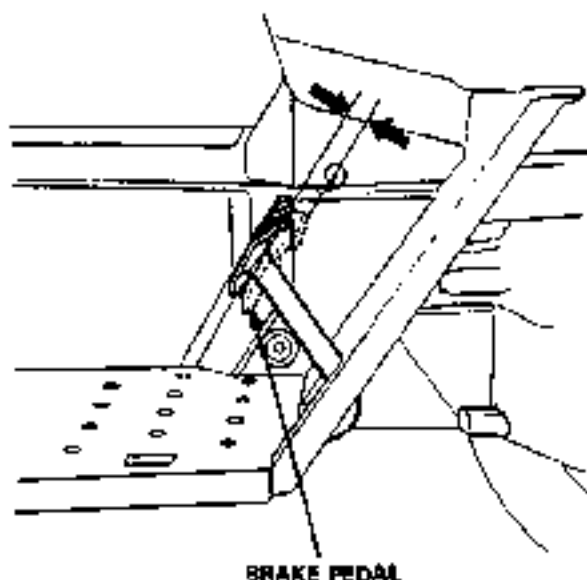



## 12. Clutch pedal free play

Measure the clutch pedal free play from fully released to the point you can feel resistance. Free play should be 2–15 mm (0.08–0.6 in).

If free play is out of specification, consult your authorized Honda tractor dealer.

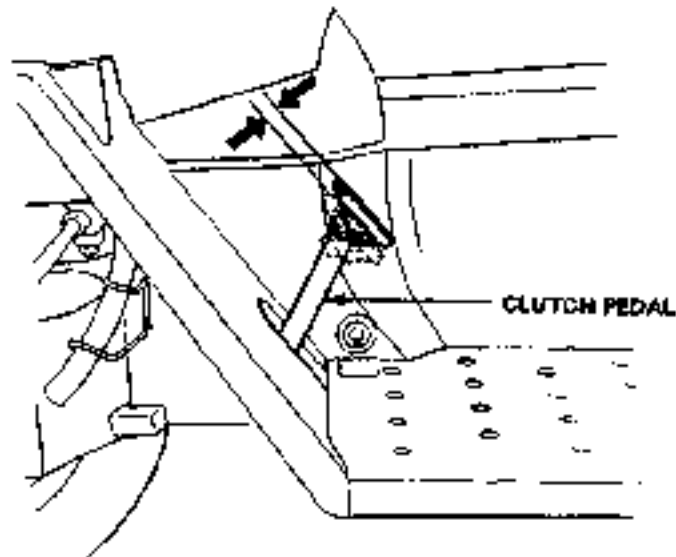

## 13. Differential lock pedal free play

Measure the differential lock pedal free play from fully released to the point you can feel resistance.

Free play should be 3–10 mm (0.1–0.4 in).

If free play is out of specification, consult your authorized Honda tractor dealer.

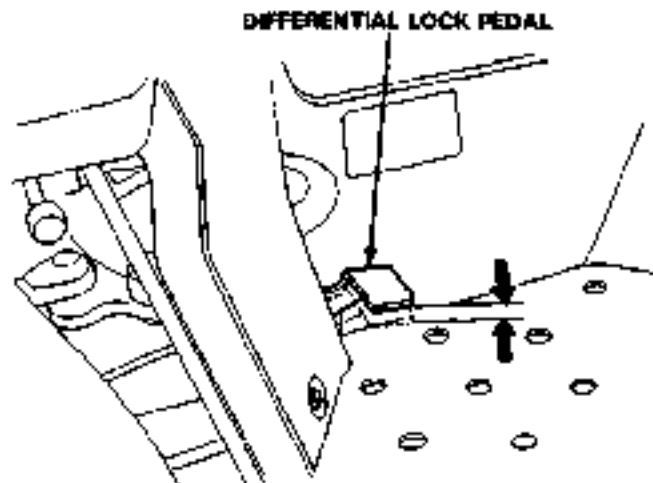

#### 14. Tires/Wheels

- Check the tire pressure with a pressure gauge.  
Tire pressure: Front 1.0 kg/cm<sup>2</sup> (14.2 psi) Rear 0.8 kg/cm<sup>2</sup> (11.4 psi)
- Check that the lug nuts on each wheel are securely tightened.  
Torque: 13 kg-m (94 ft-lb)

**CAUTION:** Every day, check the lug nuts for security for the first 20 hours of operation, and retighten if necessary. Thereafter, re-check and retighten them every 50 hours.

- Check side wall and tread surface of each tire for cracks, damage, or excessive wear.

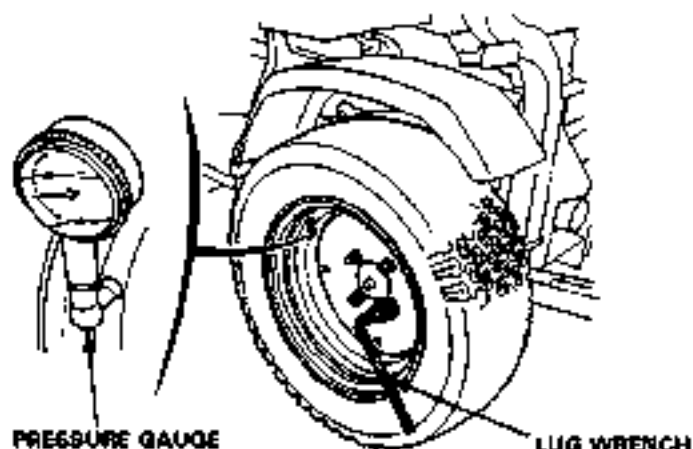

#### 15. Hydraulic lift system fluid

**CAUTION:** Before performing this inspection, lower the front and rear lift arms fully and confirm they are at their lowest positions by pushing them then down by hand.

Remove the filler cap, wipe off the dipstick and reinsert it. Remove it again, and if the level is near the lower level mark, add the specified fluid to the upper level.

**CAUTION:** Do not fill the tank beyond the upper level. If this level is exceeded, it will result in an excessive rise in the fluid temperature and subsequent damage to the hydraulic system.

Recommended fluid: HONDA power steering fluid

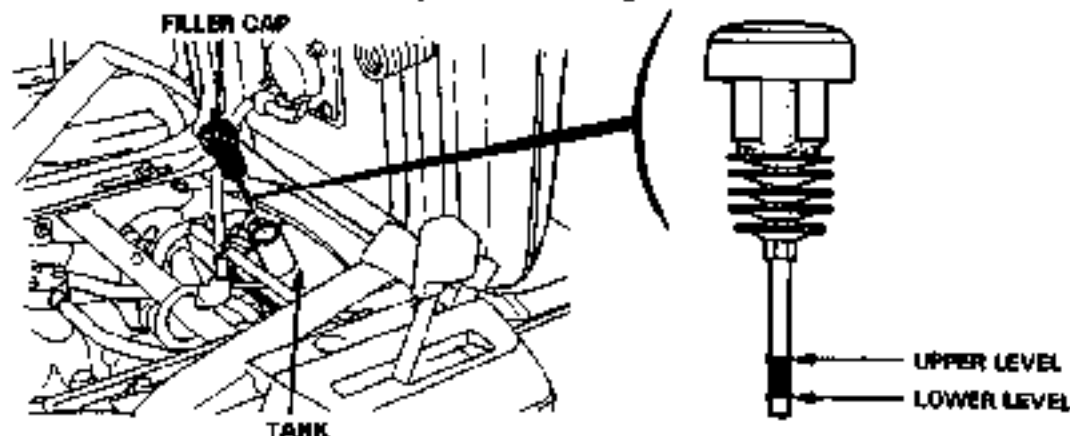

**NOTE:** If the fluid level drops rapidly or repeatedly, the system requires service by an authorized HONDA tractor dealer.

---

## 16. Seat position

Make sure the seat and seat belt are properly adjusted and securely mounted. If necessary:

1. Loosen the seat mounting bolts.
2. Move the seat forward or back as necessary.
3. Tighten the seat and seat belt mounting bolts securely.

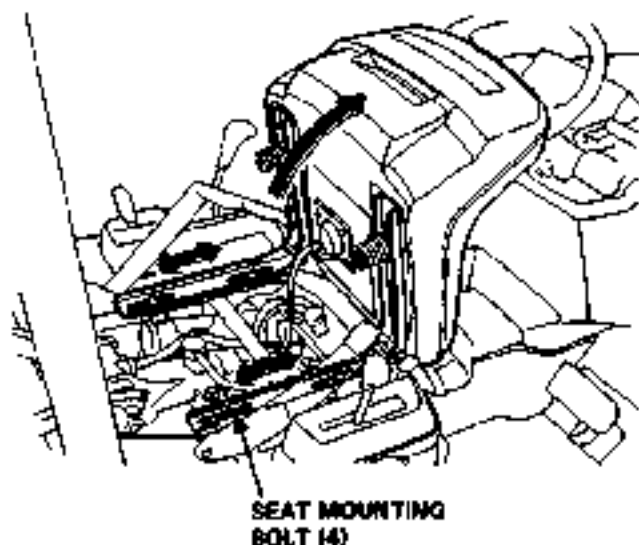

## 17. Steering

Check the steering free play with the wheels straight ahead. There should be less than 30 mm (1.2 in) of steering wheel rotation before the front wheels start to turn. Push the steering wheel up and down, and in and out; There should be no measurable movement.

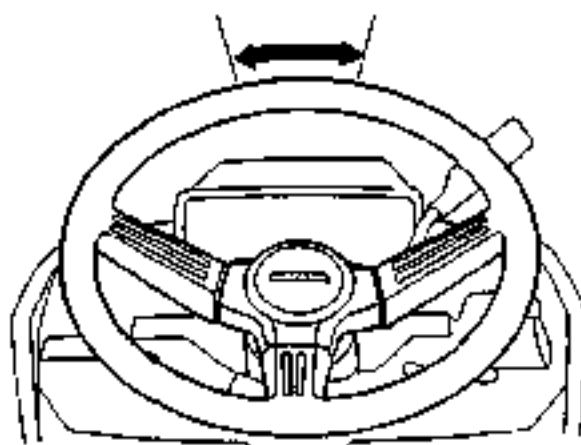

## 18. Fuel level.

Turn the engine switch ON and check the fuel gauge.

Refill the tank if the fuel level is low. Remove the filler cap and add gasoline up to the lower edge of the filler neck. Fuel tank capacity is 8.5 ℓ (2.2 US gal).

Your engine is designed to use any gasoline that has a pump octane number ( $\frac{R+M}{2}$ ) of 86 or higher, or that has a research octane number of 91 or higher. Gasoline pumps at service station normally display the pump octane number.

We recommend that you use unleaded fuel because it produces fewer engine and spark plug deposits and extends the life of exhaust system components.

Never use stale or contaminated gasoline or an oil/gasoline mixture. Avoid getting dirt, dust or water in the fuel tank. Use of a lower octane gasoline can cause persistent "pinging" or heavy "spark knock" (a metallic rapping noise) which, if severe, can lead to engine damage.

**CAUTION:** If "spark knock" or "pinging" occurs at a steady engine speed under normal load, change brands of gasoline. If spark knock or pinging persists, consult your authorized Honda dealer. Failure to do so is considered misuse, and damage caused by misuse is not covered by Honda's Limited Warranty.

Occasionally you may experience light spark knock while operating under heavy loads. This is no cause for concern, it simply means your engine is operating efficiently.

### ⚠ Warning

- Gasoline is extremely flammable and is explosive under certain conditions.
- Refuel in a well-ventilated area with the engine stopped. Do not smoke or allow flames or sparks in the area where the engine is refueled or where gasoline is stored.
- Do not overfill the fuel tank (there should be no fuel in the filler neck). After refueling, make sure the tank cap is closed properly and securely.
- Be careful not to spill fuel when refueling. Spilled fuel or fuel vapor may ignite. If any fuel is spilled, make sure the area is dry before starting the engine.
- Avoid repeated or prolonged contact with skin or breathing of vapor. **KEEP OUT OF REACH OF CHILDREN.**

After refueling, be sure to tighten the fuel tank cap firmly.

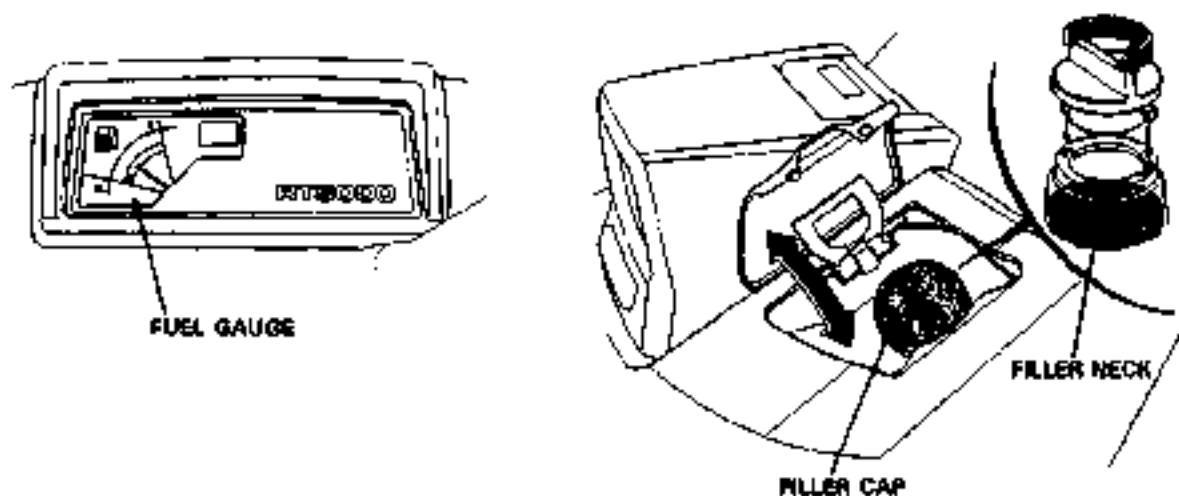

---

## **GASOLINES CONTAINING ALCOHOL**

If you decide to use a gasoline containing alcohol (gasohol), be sure it's octane rating is at least as high as that recommended by Honda. There are two types of "gasohol": one containing ethanol, and the other containing methanol. Do not use gasohol that contains more than 10% ethanol. Do not use gasoline containing methanol (methyl or wood alcohol) that does not also contain cosolvents and corrosion inhibitors for methanol. Never use gasoline containing more than 5% methanol, even if it has cosolvents and corrosion inhibitors.

### **NOTE**

- Fuel system damage or engine performance problems resulting from the use of fuels that contain alcohol is not covered under the warranty. Honda cannot endorse the use of fuels containing methanol since evidence of their suitability is as yet incomplete.
- Before buying fuel from an unfamiliar station, try to find out if the fuel contains alcohol, if it does, confirm the type and percentage of alcohol used. If you notice any undesirable operating symptoms while using a gasoline that contains alcohol, or one that you think contains alcohol, switch to a gasoline that you know does not contain alcohol.

## 19. Parking brake

Make sure that the parking brake and buzzer system operate properly. Turn the engine switch ON, move the main transmission lever to any gear position (other than NEUTRAL), push the brake pedal and apply the parking brake lock lever. The buzzer should sound until the parking brake is released or the shift lever is moved to NEUTRAL.

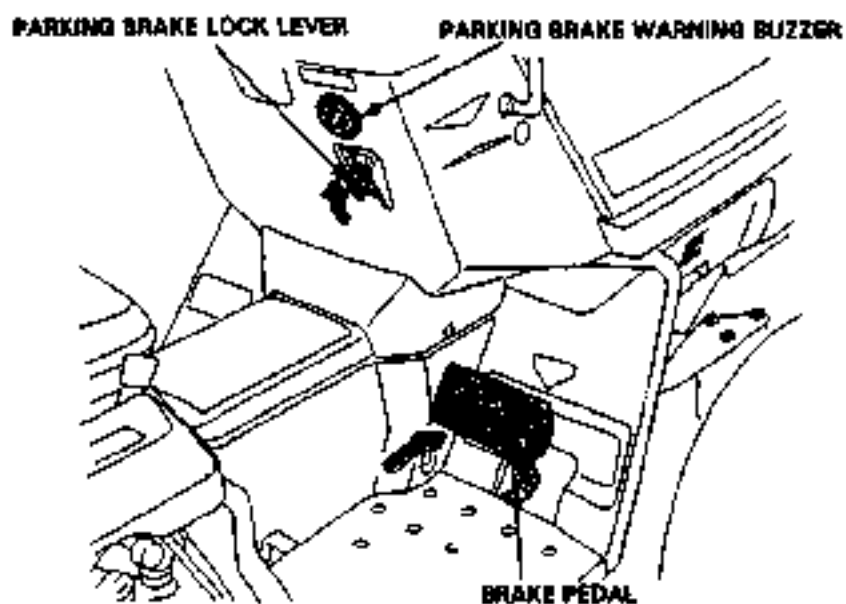

## 20. Headlight

Turn the engine switch ON and check the headlight by operating the headlight switch.

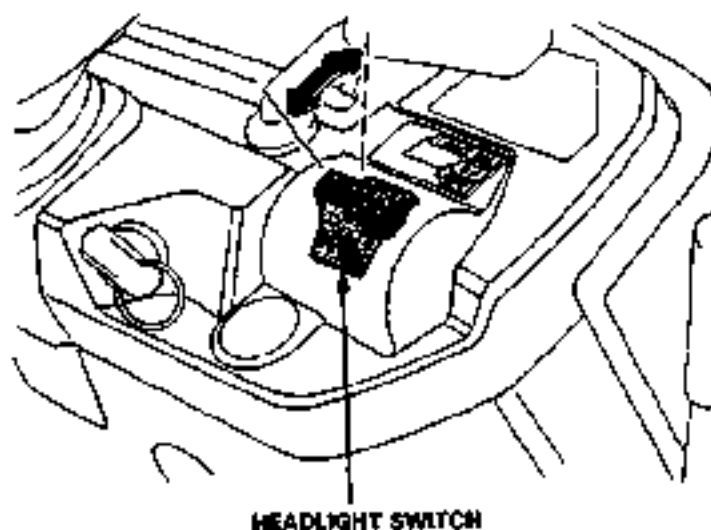

## 21. Safety interlock system

**WARNING:** Before inspecting, ensure that the area in front of and behind the tractor is clear of people, pet and obstacles.

This tractor is equipped with a series of inhibitor switches which prevent the engine from being started unless the proper operating procedures are followed. Observe the following procedures to check the inhibitor switches.

**WARNING:** Do not operate the tractor, if there are any abnormalities in the system, or in the operation of the switches. An accident or severe personal injury could result. Consult your authorized Honda tractor dealer.

To check the system, sit in the seat, and lock the parking brake.

**CAUTION:** Be sure to remove the spark plug cap from the spark plug when performing the inspection procedures 1) to 4).

- 1. Oil level warning switch
- (1) Put the main transmission lever into NEUTRAL, and move the front and rear P.T.O. levers to OFF position.
  - (2) Turn the engine switch ON.

After the engine switch has been turned ON, check the oil level warning light to see that it goes on, for few seconds and then goes out. Return the engine switch key to OFF.

- 2. Neutral switch
- (1) Move the front and rear P.T.O. levers to the OFF position.
  - (2) Place the main transmission lever in "1" or "2."
  - (3) Depress the brake pedal enough to release the parking brake.
  - (4) With the brake pedal and clutch pedal held down, turn the engine switch key to START. The starter should not operate.
  - (5) Put the main transmission lever into NEUTRAL.
  - (6) Return the engine switch key to OFF.

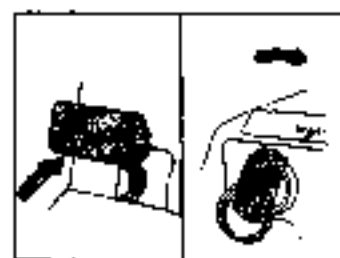
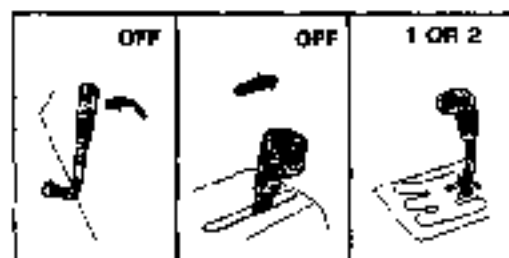
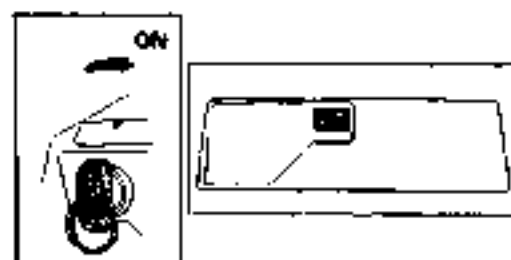
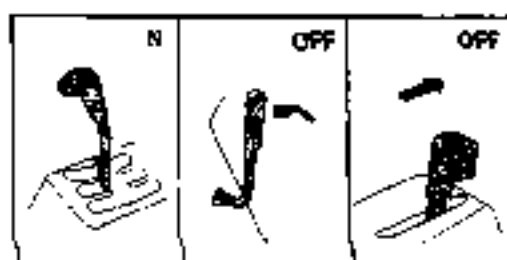

### -3. Front P.T.O. switch

- (1) Move the main transmission lever to NEUTRAL, and the rear P.T.O. lever to OFF.
- (2) Move the front P.T.O. clutch lever to ON.
- (3) Turn the engine switch key to START. Make sure that the starter does not operate.
- (4) Move the front P.T.O. clutch lever OFF.
- (5) Return the engine switch key to OFF.

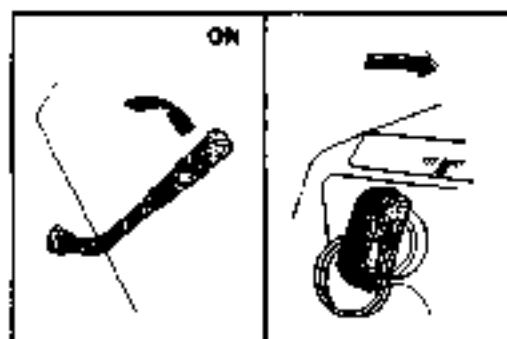
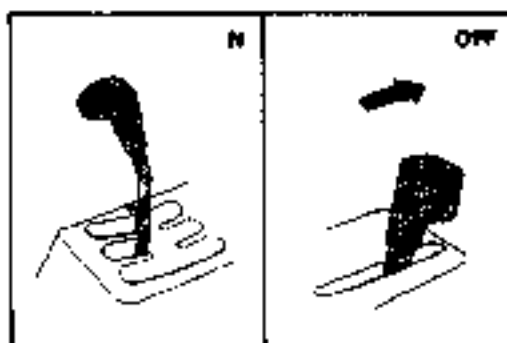

### -4. Rear P.T.O. switch

- (1) Move the main transmission lever to NEUTRAL, and the front P.T.O. clutch lever to OFF.
- (2) Move the rear P.T.O. lever to ON.

**NOTE:** If difficulty is encountered in shifting the rear P.T.O. lever, operate the starter for 2 or 3 seconds by turning the engine switch key to START.

Do not depress the clutch pedal during this operation.

- (3) Turn the engine switch key to START.  
The starter should not operate.
- (4) Move the rear P.T.O. lever OFF.
- (5) Return the engine switch key to OFF.

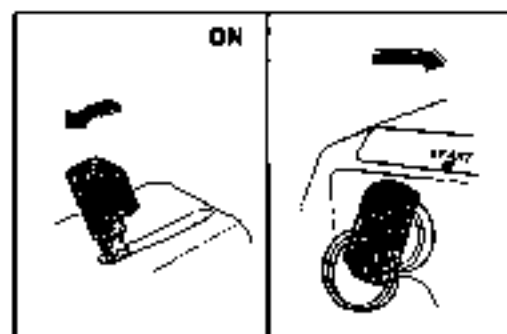
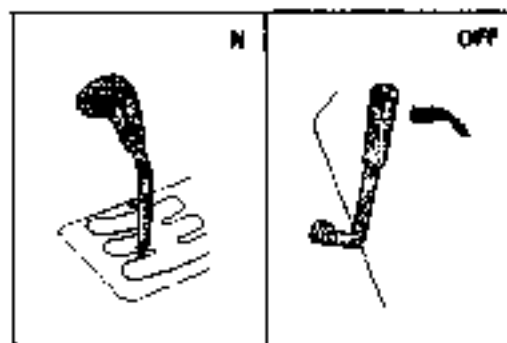



## -5. Seat switch

**NOTE:** To make this inspection, it is necessary to start the engine. Attach the spark plug cap to the spark plug securely. To start, refer to the procedures described on Page 41.

- (1) Lock the parking brake and put the main transmission lever in **NEUTRAL**.
- (2) Move the front and rear P.T.O. levers **OFF**.
- (3) Start the engine.
- (4) Move the front P.T.O. lever to **ON**.
- (5) Rise up slightly off the seat. The engine should stop as soon as your weight leaves the seat.
- (6) Return the front P.T.O. lever to **OFF** and turn off the engine switch key.

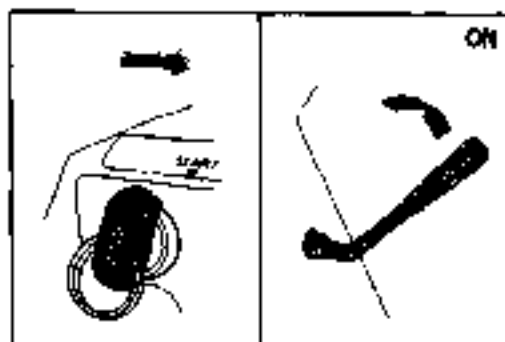

## 22. Hydraulic lift system

### NOTE:

- To make this inspection, it is necessary to start the engine; refer to the procedures described on Page 41.
- This inspection should be made with an attachment mounted on the tractor.
- The check procedure is the same for the front or rear attachment lifts. Check either, by selecting the appropriate hydraulic cylinder change lever position.

- (1) Start the engine.
- (2) Set the hydraulic cylinder change lever in **FRONT** or **REAR**.
- (3) Move the lift lever to **FAST** or **SLOW UP** position, then release your hand from the lever.

Check that the lift lever returns to **NEUTRAL**.

- (4) Check that the attachment is lowered when the lift lever is moved to the **DOWN** or **SLOW DOWN** position.
- (5) Check the descent speed and adjust descent speed if necessary, see page 24.

## 6. OPERATION

### 1. Starting the engine

**WARNING** Never run the engine in an enclosed area. Be sure to provide adequate ventilation. Exhaust contains poisonous carbon monoxide gas that may cause loss of consciousness and lead to death.

1. Make sure you are sitting squarely on the seat and the seat belt is securely fastened around your hips.
2. Make sure the main transmission lever is in NEUTRAL, both the front and rear P.T.O. levers are OFF and the lift lever is in the center (Neutral) position.

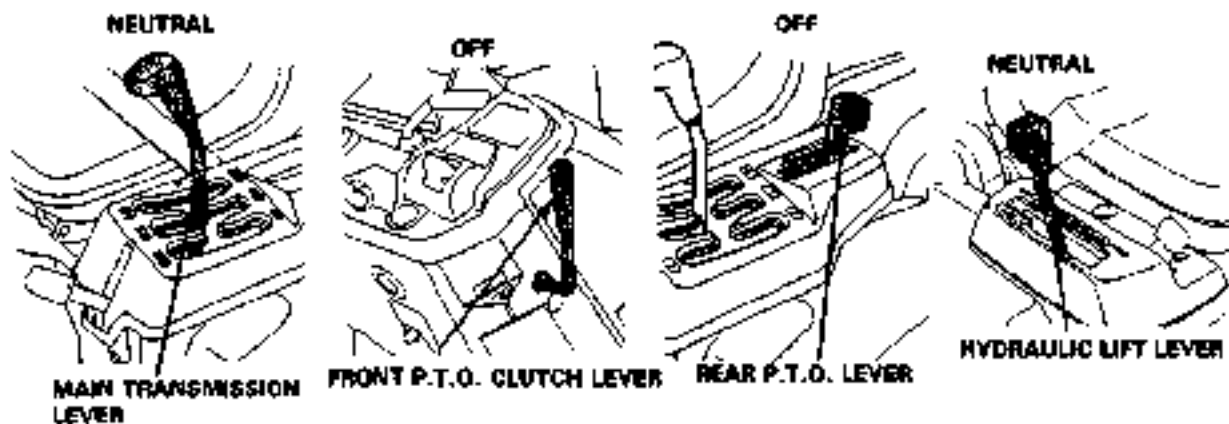

3. Pull the choke knob all the way out and move the throttle lever to the middle (1/2) position.

**NOTE:** When the engine is warm or the air temperature is high, do not use the choke.

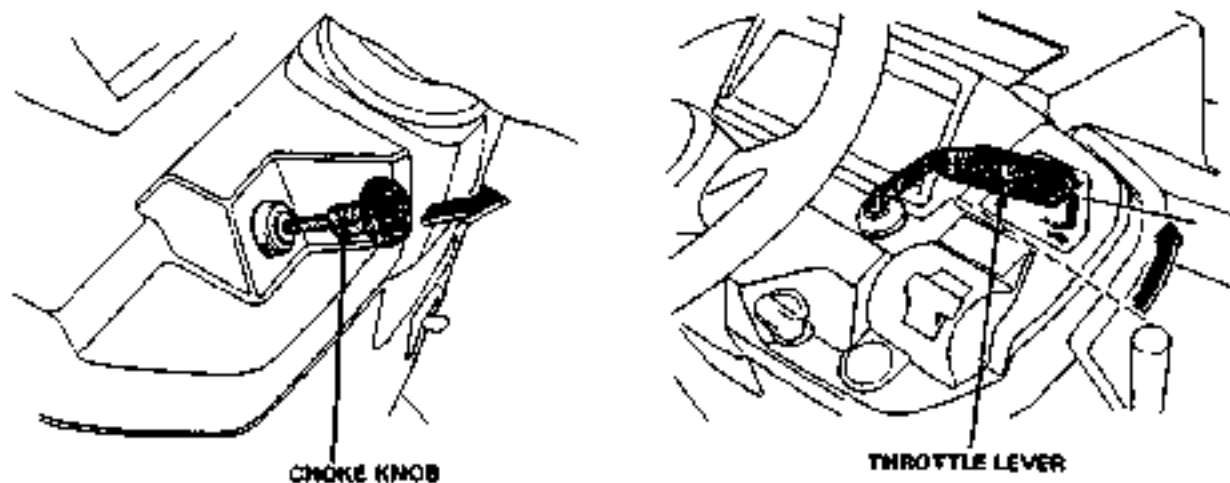

- 
4. Turn the engine switch key to "START" and release the key when the engine starts.

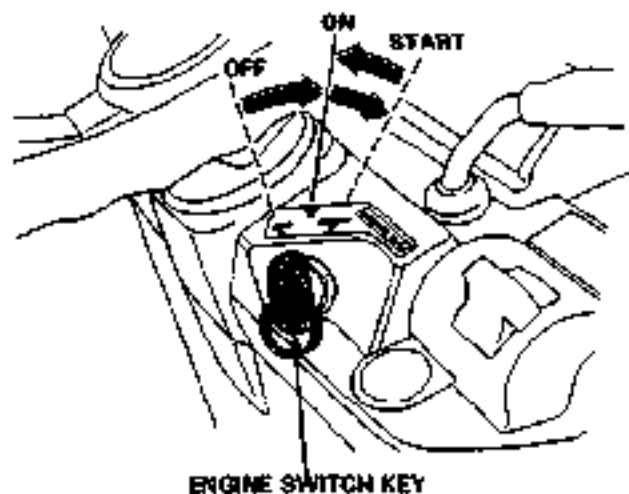

**CAUTION:** Do not use the starter motor for more than 5 seconds. If the engine fails to start, release the key, and wait at least 10 seconds before operating the starter motor again.

5. As the engine warms up, gradually push the choke knob to the OFF position.

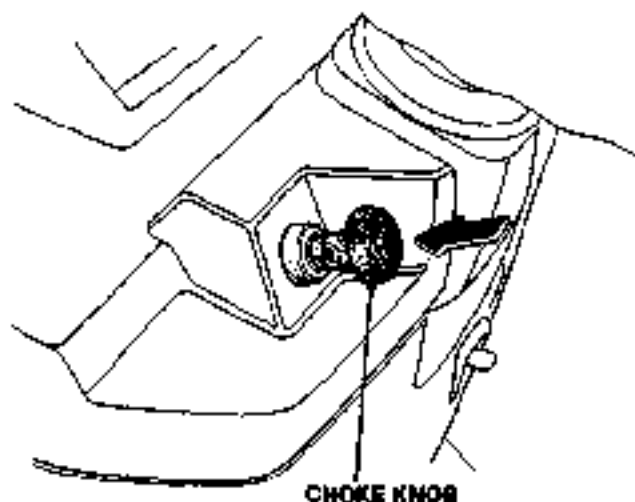

6. As the engine stabilizes, gradually move the throttle lever to the SLOW position.

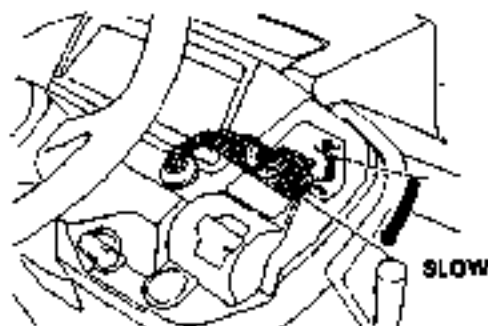

## 2. Starting/driving

**WARNING** Before operating the Tractor or its attachments, read and understand the tractor safety instructions (pages 6–8).

- 1. Depress the clutch pedal and place the main and auxiliary transmission levers in the desired gear range for operation.

**NOTE:** When the main transmission lever is engaged, a warning buzzer will sound to notify the driver if the parking brake is applied.

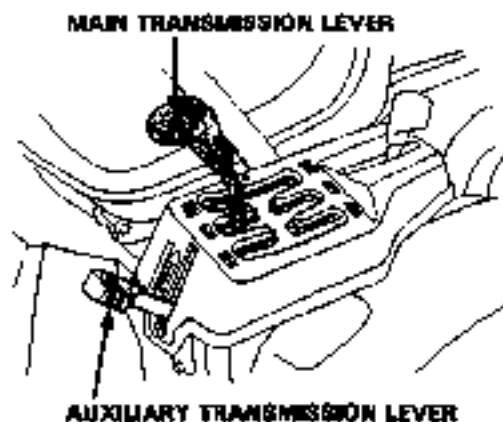
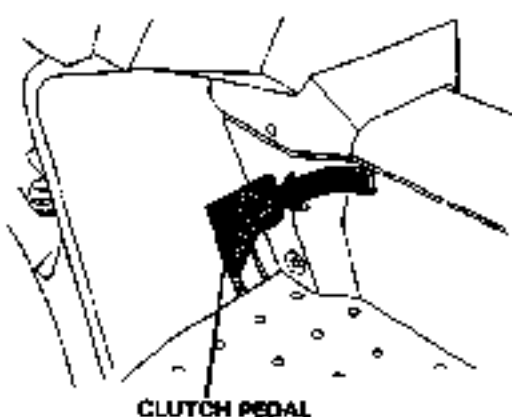

- 2. Depress the brake pedal and release the parking brake lock lever.

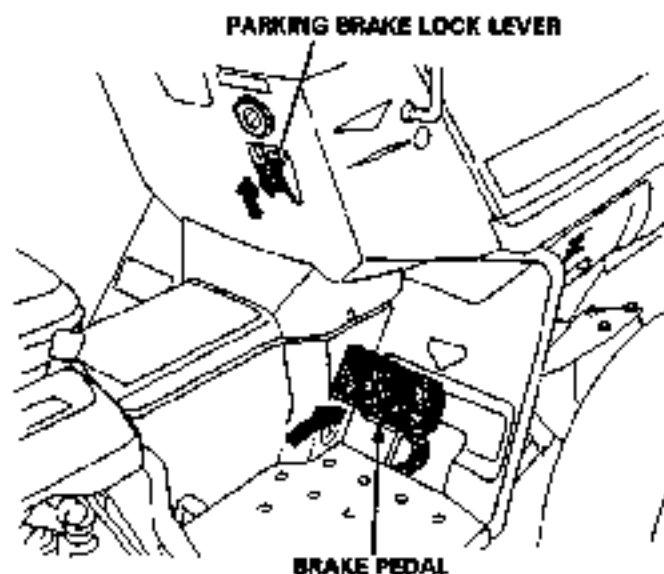

- 
- 3. Raise the throttle lever slightly and slowly release the clutch pedal.

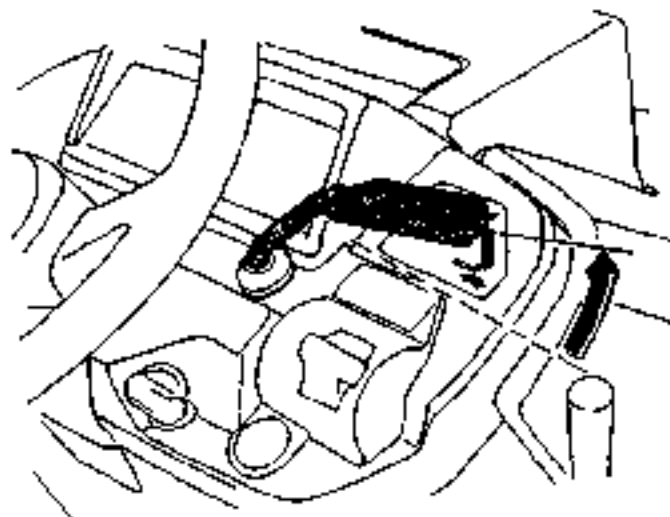

**WARNING** Always release the clutch pedal slowly when starting the tractor in motion. Sudden starts can damage the equipment or cause loss of vehicle control that may result in severe personal injury.

**CAUTION**

- Do not start out suddenly or with the steering wheel turned to one side.
- Do not rest your foot on either the clutch pedal or differential lock pedal while the tractor is running.

### 3. How to use the differential lock

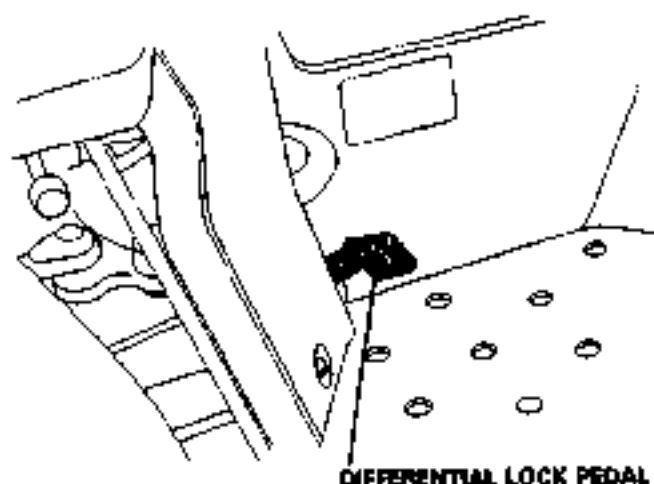

**WORKING TIP** When used properly, the differential lock is extremely convenient. However, unskilled operation could cause the vehicle to overturn; it could also damage the drive train. Take care when using the differential lock.

The differential lock is most useful in situations where a slippery or loose surface causes one of the rear wheels to lose traction.

#### Operation

1. Shift the main transmission lever into 4th or lower gear range.
2. With the steering wheel held straight-ahead, depress and hold the differential lock pedal. As long as you continue to depress the pedal, the differential lock will be applied.
3. To release the differential lock, remove your foot from the lock pedal, bring the tractor to a full stop, shift the main transmission from FORWARD to REVERSE or vice versa, and drive a short distance.

**WORKING TIP** The differential lock must be released before operating the tractor on hard surfaces or slopes, or while turning. Otherwise the tractor may overturn, causing severe personal injury.

#### CAUTION:

To avoid damage to transmission mechanism.

- Do not apply the differential lock while the wheels are turning.
- Do not rest your foot on the differential lock pedal unless you want to engage the differential lock.
- Do not apply the brakes when the differential lock is in use.
- Check that the differential lock has been released after you have finished using it.
- Do not apply the differential lock while driving at high speed.
- Do not apply the differential lock on a hard packed surface.

#### 4. Turning

This tractor has Four Wheel Steering.

**WARNING** Never make abrupt starts while the wheels are turned. If the front wheels rise off the ground, loss of steering control could result in an accident causing severe personal injury or property damage.

#### CAUTION:

- Slow down as much as possible when turning the vehicle.
- When turning with a front or rear attachment fitted, be sure to raise the attachment first, and compensate for its effect on the total length of the tractor.
- Use care when turning the tractor near a wall or other obstruction when a rear mounted attachment is being used. 4-wheel steering allows the tractor to turn in a very small radius; however, the attachment will swing out in a larger arc than the tractor, and may strike nearby objects.
- Do not turn the tractor with the differential lock applied.
- Steering wheel in straight ahead position:

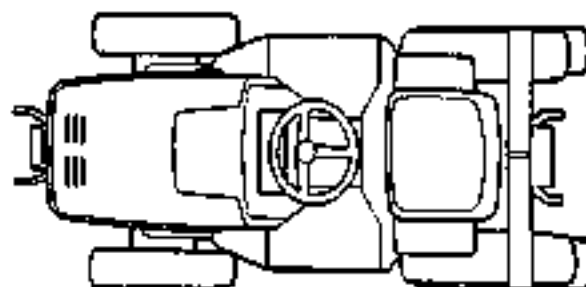

- Steering wheel slightly turned:  
Both the front and rear wheels turn in the same direction.

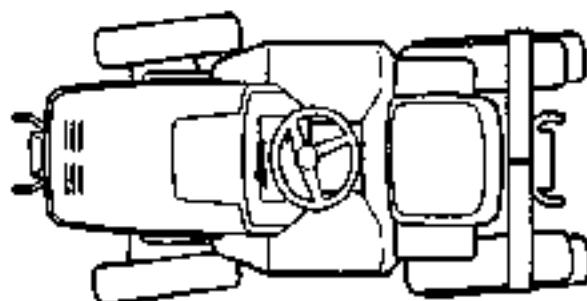

- Steering wheel fully turned:  
Rear wheels turn in the opposite direction of the front wheels, to produce the maximum steering angle.

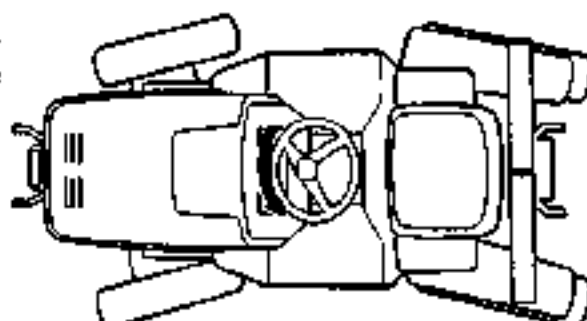

## 5. ATTACHMENT LIMITATIONS

Use of Honda attachments is recommended. If an attachment exceeds the limits shown below or it is not suited to RT5000, or if the counterweights used do not conform to the sizes and weights specified in "Counterweight Table", they may not only endanger men or equipment but also prevent you from taking the fullest advantage of your tractor.

Never use attachments which exceed sizes and weights specified.

Never use counterweights other than those specified in Counterweight Table.

Any malfunction or damage to the tractor is unwarrantable if it is the consequence of use of attachments not specified or recommended by Honda.

### • Attachment Limitations

Max. allowable load at end

of lower link .....

Attachment weight .....

Trailer load .....

Max. lifting force at lift point:  $W_0$

Max. attachment weight which can be lifted hydraulically:  $W_1$

Total weight of trailer and max. allowable load on trailer:  $W_2$

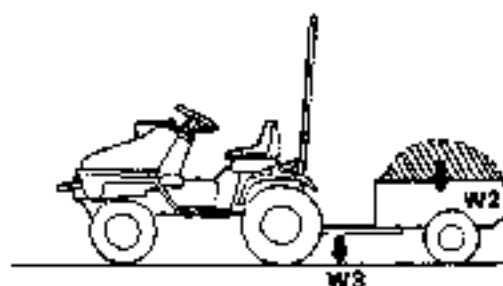
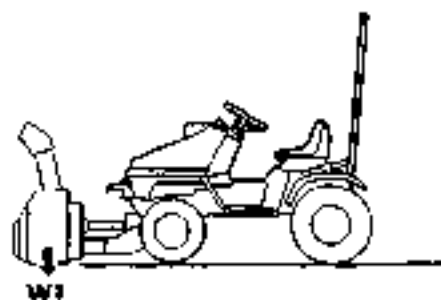

Max. load at lower link end ( $W_0$ )		250 kg (551 lbs)	Installation should be based on "COUNTERWEIGHT TABLE."
Max. weight of attachment ( $W_1$ )		140 kg (309 lbs)	
Trailer	Max. load ( $W_2$ )	363 kg (800 lbs)	Weight of trailer included
	Load at pivot point ( $W_3$ )	$20 \pm 9$ kg ( $45 \pm 20$ lbs)	As down force



## Size and Weight Limits by Attachments

Attachment		Item	Weight and Size Limits
Rotary Mower	Mid 3-blade	Max. cutting width Max. weight	1,170 mm (46 in.) 60 kg (132 lbs)
Snow Blower		Max. intake width Max. weight	1,070 mm (42 in.) 100 kg (220 lbs)
Snow Dozer		Max. blade width Max. weight	1,170 mm (46 in.) 50 kg (110 lbs)
Rotary Tiller		Max. cultivating width Max. weight	1,070 mm (42 in.) 140 kg (309 lbs)
Plow		Max. size	300 mm (12 in.) x 1
Disc Harrow		Max. cultivating width Max. weight	1,320 mm (52 in.) 100 kg (220 lbs)
Cultivator		Max. size	1,220 mm (48 in.) (single row)
Trailer		Max. load	363 kg (800 lbs) (weight of trailer included)

**CAUTION:** The above limits are applicable if only one attachment is used on the tractor.

---

## • Towing

### **WARNING**

- Never attempt to tow anything without a trailer hitch. Failure to use a proper hitch could cause the tractor to overturn resulting in severe personal injury or equipment damage.
- Travelling and turning at high speeds while towing a trailer or other attachment is dangerous.
- Avoid sudden starts and stops while towing. The momentum of the trailer or attachment could cause loss of control resulting in an accident and severe personal injury or equipment damage.

### **CAUTION:**

- Use only those attachments which are designed for use with this vehicle. If you have any doubts about the suitability of an attachment, consult your authorized Honda tractor dealer.
- Use 1st gear when towing a trailer or attachment over rough ground.
- Remove any other attachment when using a draw plate.

#### 1. Maximum towing weight:

363 kg (800 lbs) including the weight of the trailer.

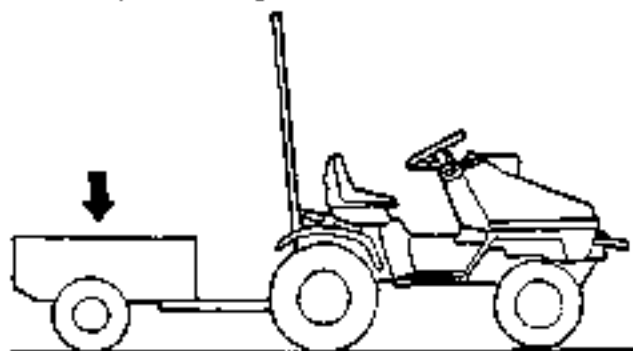

**WARNING** Exceeding the maximum towing weight could lead to loss of control and cause an accident resulting in severe personal injury or equipment damage.

#### 2. Maximum tongue weight:

20 kg ± 9 kg (45 lbs ± 20 lbs)

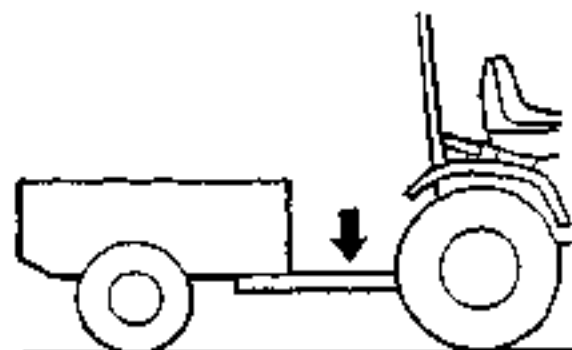

**CAUTION** If the trailer's load is unbalanced so that the tongue weight is incorrect, the tractor may overturn resulting in severe personal injury or equipment damage.

**NOTE:** Tongue weight is the downward force that the trailer exerts on the trailer hitch.

## • Counterweight

When an attachment is fitted to the FRONT or REAR, the weight balance between front and rear wheels is lost, which may lead to instability while the vehicle is running (front wheel lift, etc.). To avoid this, it is necessary to fit a counterweight to regain front-rear wheel balance.

Make suitable counterweight settings according to the list below.

**Warning** Under no circumstances should the total weight of the attachment, counterweights and wheel weights exceed 350 kg (780 lbs). Failure to follow this precaution may endanger yourself, and may cause damage to your tractor or shorten its service life.

### 1. Rear Attachment and Counterweight Table

The number in the box indicates the number of counterweights required.

**NOTE:** This table assumes that each counterweight weighs approximately 11 kg (25 lbs).

W \ L	600 mm (24 in)	800 mm (32 in)	1,000 mm (39 in)	1,200 mm (47 in)
40 kg (88 lbs)	0	0	0	0
60 kg (133 lbs)	0	0	0	1
80 kg (178 lbs)	0	0	1	2
100 kg (222 lbs)	0	1	2	3
120 kg (267 lbs)	1	2	3	4
140 kg (311 lbs)	2	3	4	*

L: Distance between center of attachment side wheel and center of gravity of attachment.  
W: Weight of attachment  
C.G.: Center of gravity

Any attachments which exceed the sizes and weights shown in the table to the left should not be used.

0: Counterweight unnecessary

\*: Attachment should not be used

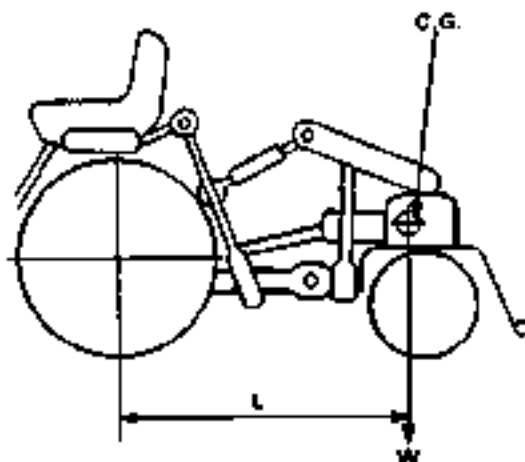

## 2. Front Attachment and Counterweight Table

The number in the box indicates the number of counterweights required.

**NOTE:** This table assumes that each counterweight weights approximately 11 kg (25 lbs).

W \ L	600 mm (24 in)	800 mm (32 in)	1,000 mm (39 in)	1,200 mm (47 in)	1,400 mm (55 in)
60 kg (133 lbs)	1	2	3	6	5
80 kg (178 lbs)	3	5	6	7	
100 kg (222 lbs)	5	7	8		
120 kg (267 lbs)	7	8			*
140 kg (311 lbs)	8				

\* Attachment should not be used.

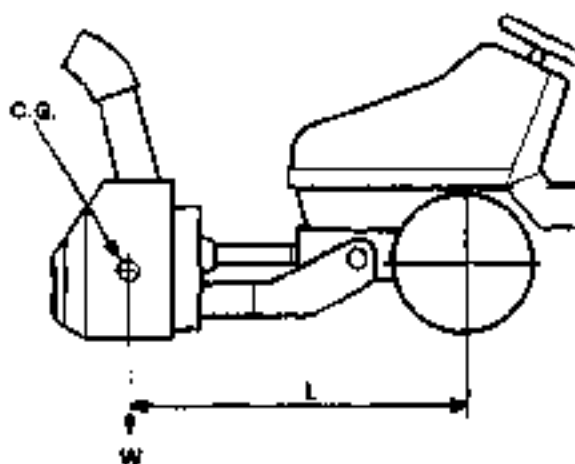

## 6. Driving on a slope

Before starting up or down a long incline, select one of the lower gear ranges, so that tractor speed is reduced, but engine speed is high for maximum control.

**Warning:** Attempting to change gears while operating the tractor on a slope may adversely affect vehicle stability and control and severe personal injury could result.

### CAUTION:

- Avoid parking on a slope. If necessary, apply the parking brake and place blocks on the downhill side of each wheel.
- Do not drive across a slope; Always drive in the same direction as the angle of the slope.
- Do not use the differential lock on a slope.

### UPHILL STARTING PROCEDURE

If possible avoid stopping the tractor while driving uphill. If it is necessary to stop on a hill, follow the special procedure below when restarting:

#### Warning:

- If this procedure is not followed when restarting on an uphill slope the tractor may roll backwards during clutch engagement, and this could cause it to tip over resulting in severe personal injury.
- Abruptly applying the brake pedal while the tractor is rolling backwards down a slope may cause the tractor to tip over.

- A. Depress the brake pedal.
- B. Move the throttle lever to "FAST" position.
- C. Depress the clutch pedal and then move the transmission lever to 1st gear position.
- D. Release the clutch pedal first, then release the brake pedal.

**Warning:** If the brake pedal is released before the clutch pedal, the tractor may go back down. Never make hard braking. It may cause the tractor to tip over.

## 7. Special Obstacles:

- 1. To safely cross drainage ditches or embankments, use a ramp to reduce the effective angle of the obstacle to less than 15°.

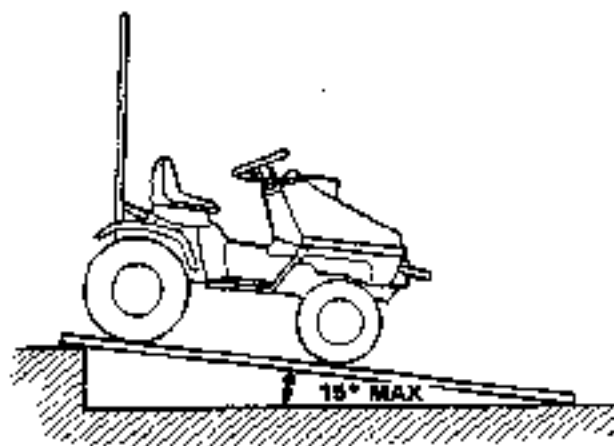

- 2. Avoid swampy or muddy areas deep enough to reach the center line of the wheels. The tractor can become stuck, especially if it is carrying attachments.

## 8. Stopping the engine

- In an emergency:  
Turn the engine switch OFF.  
Depress the clutch and brake pedal.
- In normal use:
  - 1. Move the throttle lever to "SLOW."

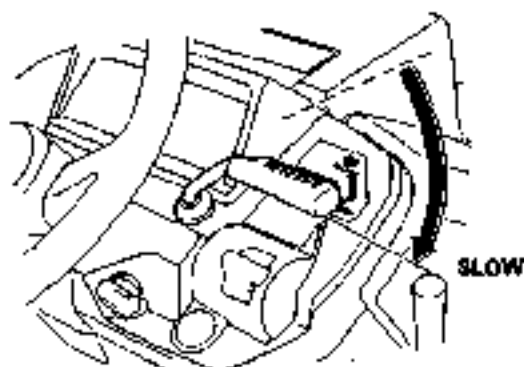

- 2. Depress the clutch and brake pedals simultaneously.  
Move the main transmission lever to "NEUTRAL".

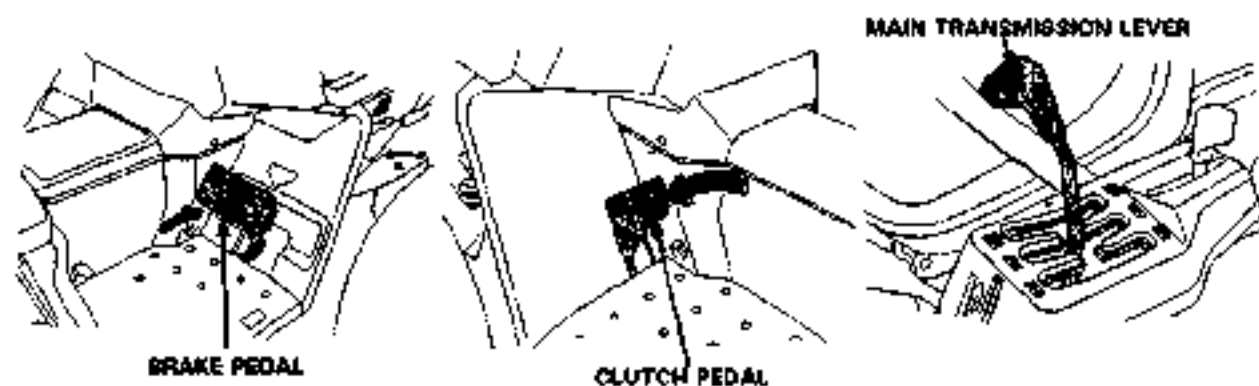

- 3. Shift the front and rear P.T.O. levers to the "OFF" position.

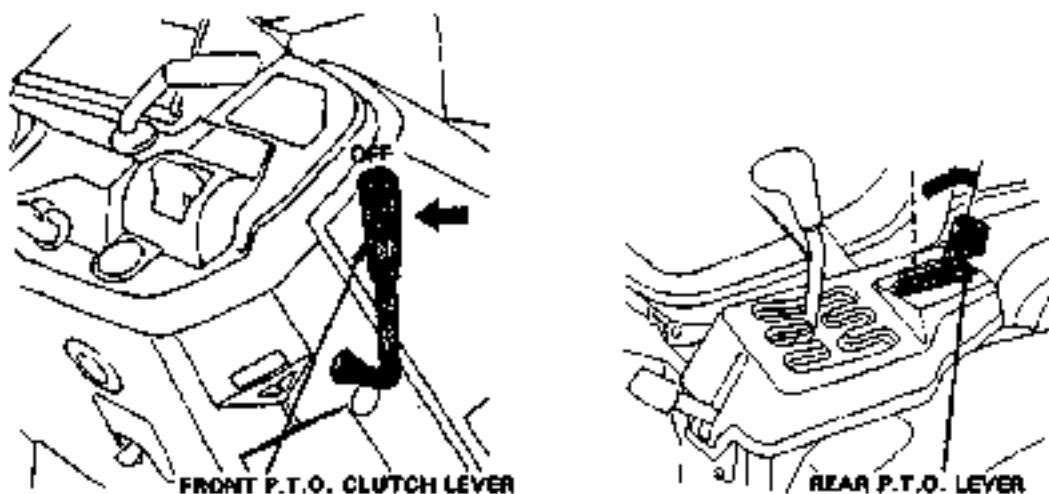

- 
- 4. Lower any attachment to the ground with the hydraulic lift lever.

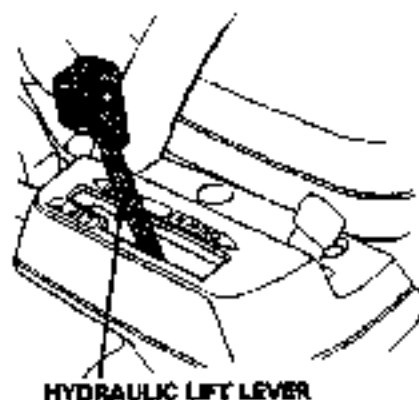

- 5. Turn the engine switch to "OFF" and remove the key.

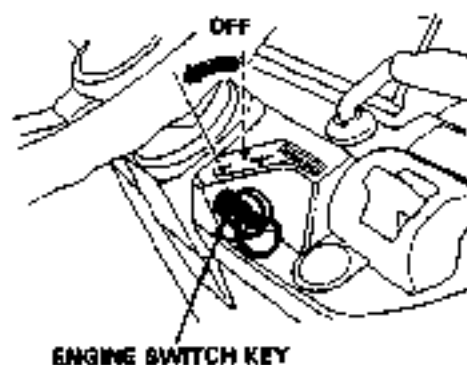

- 6. Push down the park brake lock lever while depressing the brake pedal.

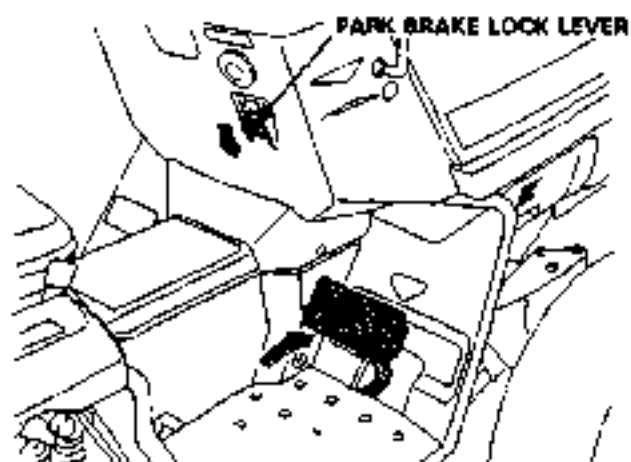

**CAUTION:** To avoid injury to yourself and others, before leaving the tractor unattended, **ALWAYS:** park on level ground, disengage the power take-off (P.T.O.), lower the attachment, shift into neutral, set the parking brake, stop the engine and remove the key.

---

### 9. Recommended working speed

Select a safe and correct operating speed as per the instructions shown in the chart below.

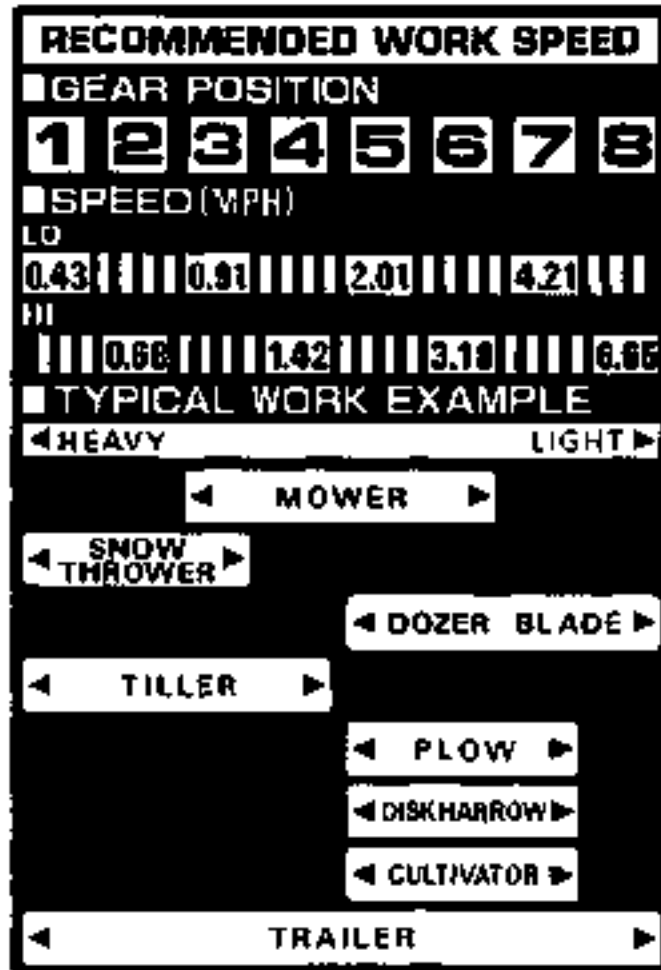



---

## 10. High altitude operation

At high altitude, the standard carburetor air-fuel mixture will be excessively rich. Performance will decrease, and fuel consumption will increase.

High altitude performance can be improved by installing a smaller diameter main fuel jet in the carburetor and readjusting the pilot screw. If you always operate the tractor at altitudes higher than 6,000 feet above sea level, ask your authorized Honda dealer perform these carburetor modifications.

Even with suitable carburetor jetting, engine horsepower will decrease approximately 3.5% for each 1,000 foot increase in altitude. The effect of altitude on horsepower will be greater than this if no carburetor modification is made.

**CAUTION:** Operation of the tractor at an altitude lower than the carburetor is jetted for may result in reduced performance, overheating, and serious engine damage caused by an excessively lean air/fuel mixture.

## 7. TRANSPORTING

### Transporting

**WARNING:** Spilled fuel may ignite. To avoid fuel and oil spillage, keep the tractor level when transporting.

**CAUTION:** Do not pull the tractor behind another vehicle, and do not use the tractor to push another vehicle.

Transport the tractor on a flat, level heavy duty trailer.

1. Use a loading ramp that is strong enough to support the combined weight of the tractor, its attachments and the operator. The loading ramp must be long enough so that its slope is  $15^{\circ}$  or less.
2. Use reverse gear 1 or 2 to back the tractor up the ramp.

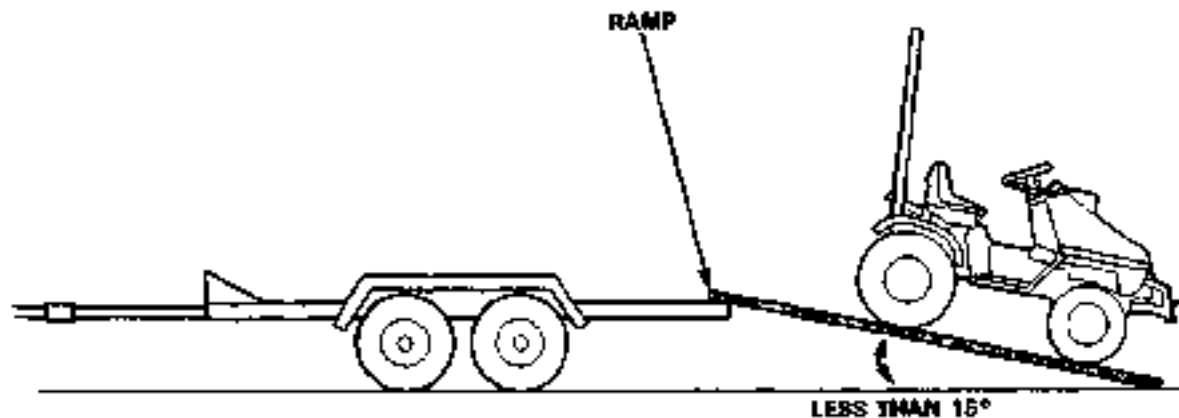

**CAUTION:** If the engine stalls during loading, immediately depress the brake pedal and clutch pedal, then let the tractor roll down the ramp by slowly releasing the brake pedal.

3. After loading, apply the parking brake and remove the engine switch key.
4. Tie the tractor down securely, using the tie down points shown below.

### CAUTION:

- Do not use the tie-rods or brake rod to tie the tractor down. Damage could result.
- Use heavy-duty straps, chains, or cables to fasten tractor to the trailer. Both front and rear straps must be directed down and outward from tractor.



## 8. INSTALLING AN ATTACHMENT

Before installing or using any attachment, carefully read all instructions and precautions.

**CAUTION:** To prevent accidental start-up, remove the engine switch key, and disconnect the spark plug cap before installing or adjusting attachments.

**CAUTION:** Park the tractor on firm, level ground, apply the parking brake lock, set the shift lever in "N (Neutral)" and the front and rear P.T.O. levers in "OFF" positions when installing, adjusting or removing a attachment.

### 1. Rear 3-point hitch link installation (option)

- Attach the check links to the right and left lower links with the check links pins and secure with the cotter pins.
- Install the right and left lower links to the hitch box section with lower link pins.
- Insert the check links to the outside of the lower link pin and secure with a lock pin.
- Attach the lift rod pin to the lift arm.
- Install the right side of the lift rod (with the turnbuckle attached) to the right sides of the lower link and lift arm.  
Fit the left side of the lift rod to the left sides of the lower link and lift arm and secure all attachments with pins.
- Install the upper link on the cylinder mounting plate with the four bolts.
- Install and secure the upper link with the link and lock pins.
- Check that all parts are installed securely. Tighten the nuts to the specified torques.

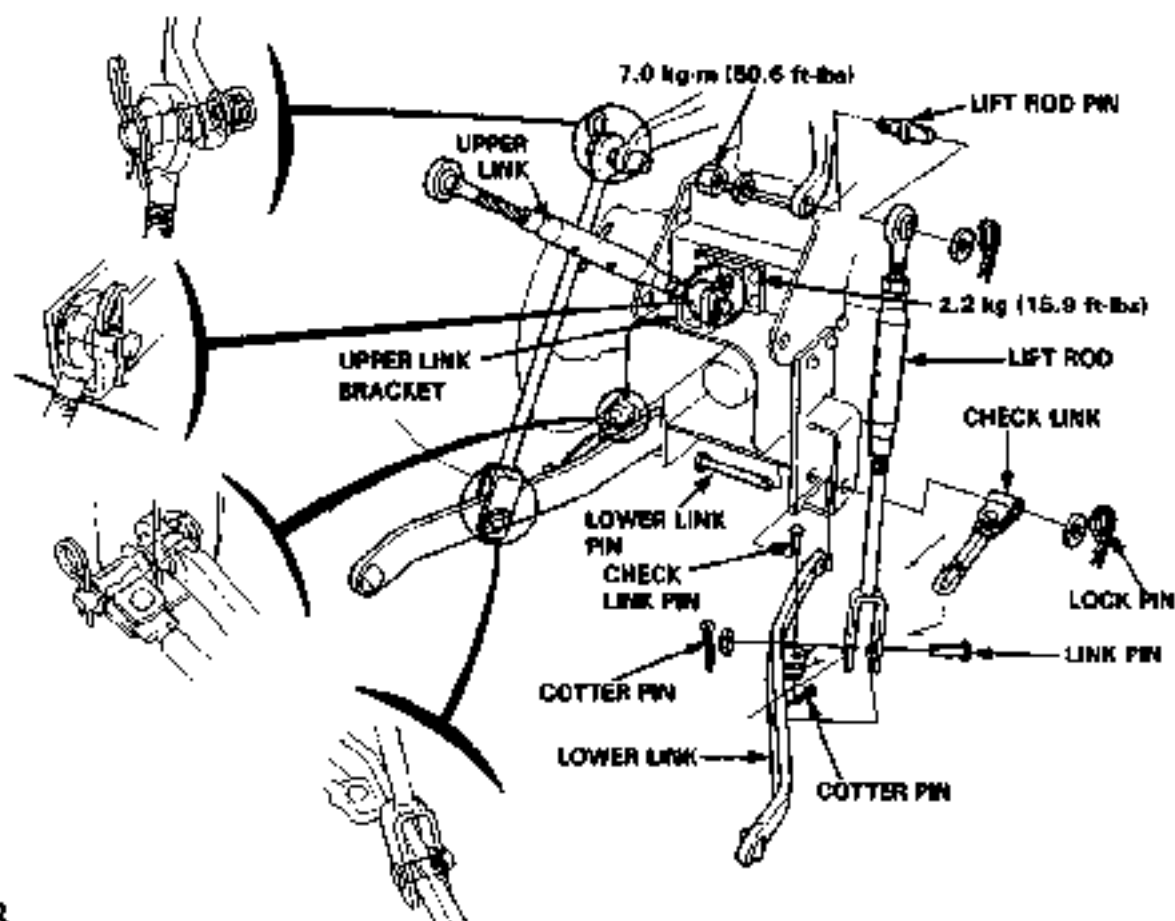

## 2. Rear 3-point hitch attachment installation

- a. Place the hydraulic switch lever to "REAR", place the lift lever in the "DOWN" position and fully lower the lower link.
- b. Slacken the check links and open the lower links as necessary.

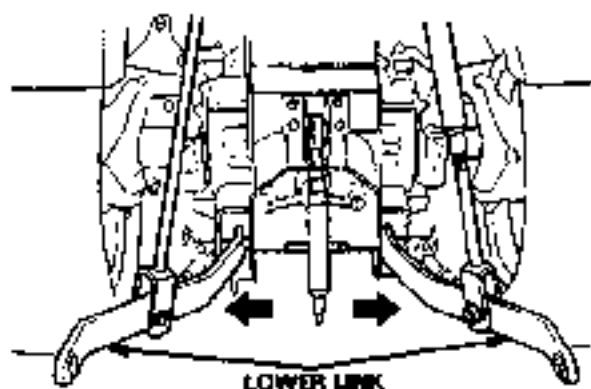

- c. Install the lower link on the left side first, then the right side using the turnbuckle adjuster to adjust for length.

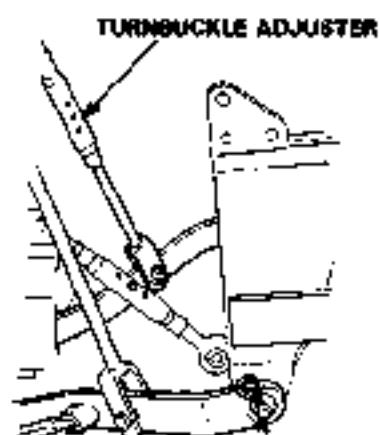

- d. Install the UPPER link to the attachment top mast.
- e. Adjust length of the UPPER link with the handle and secure with the lock nut.

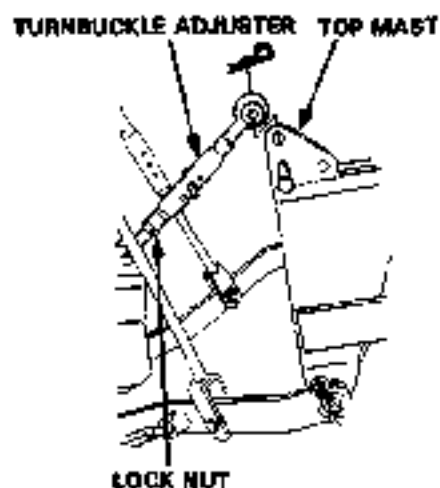

- f. Install the universal shaft.
- With the lock on the tractor side fully depressed, insert the universal shaft fully into the P.T.O. hole.
  - Release the lock, pull out the joint slowly until the lock returns to the position shown in the diagram.
  - Move the universal shaft back and forth and check that the lock is secure.

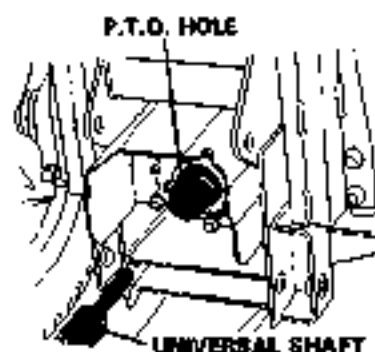

- g. Use the tumbuckle adjuster on the right side of the lift rod to get the attachment horizontal. After adjusting, secure with a lock nut.

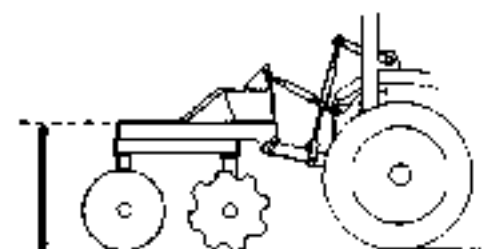
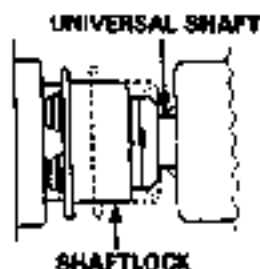

- h. Start the engine and raise the attachment slightly off the ground. Adjust the attachment with the check links so that it is parallel with the tractor. Adjust the attachment so the height difference at both ends is within 1 cm (0.4 in). Tighten the lock nut firmly.

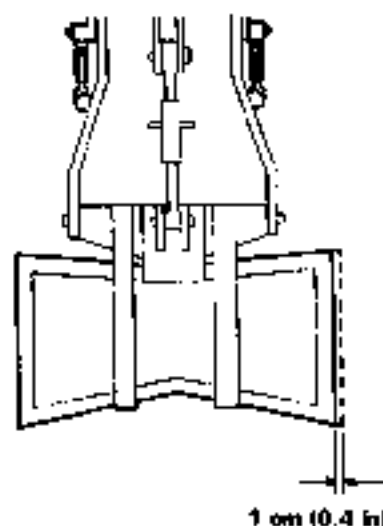

#### CAUTION:

- Before performing any checks, or adjustment of an attachment turn the speed adjusting knob (see page 24.) clockwise fully to SLOW, and set the lift lever in DOWN, and confirm that the attachment is locked. After checking, return the lever to NEUTRAL.
- Install/remove the attachments on firm, level ground.
- When installing/removing the attachments, be sure that nobody comes between the attachment and the tractor.
- After installing the attachment, check that the lock pins is securely in place.
- If there is noise from the universal shaft while driving, adjust the length of the top link slightly. If there is excessive noise from the universal shaft when in use, damage can be caused to P.T.O. section.
- If the check link is pulled too tightly, it may snap.
- Use only attachment designed for use with this tractor.

## 9. MAINTENANCE

### WARNING

- Shut off the engine and lock the parking brake before performing any maintenance.
- To prevent accidental start-up, remove the engine switch key and disconnect the spark plug cap.
- The tractor should be serviced by an authorized HONDA tractor dealer unless the owner has proper tools and service data and is mechanically qualified.

**CAUTION:** Use only genuine Honda parts or their equivalent for maintenance or repair. Replacement parts which are not of equivalent quality may damage the tractor.

Periodic inspection and adjustment of the Honda RT5000 is essential if high level performance is to be maintained. Regular maintenance will also ensure a long service life. The required service intervals and the kind of maintenance to be performed are described on the following page.

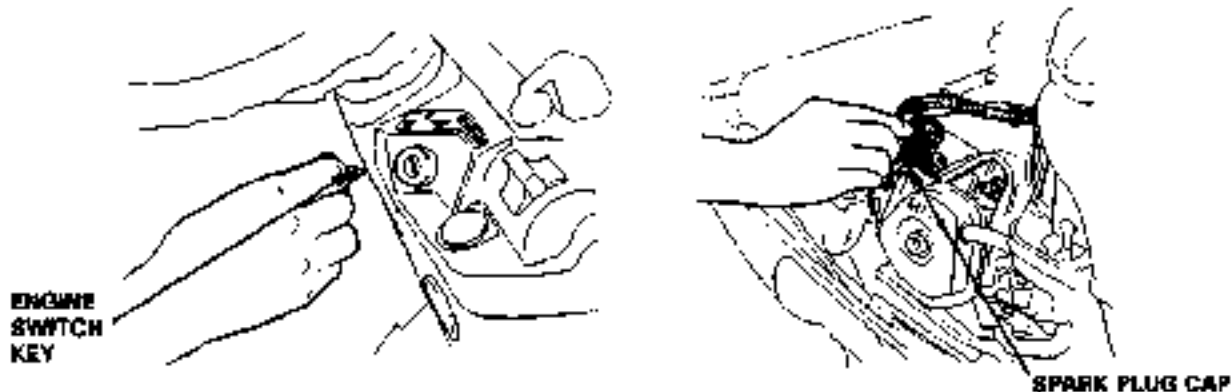

### 1. Tool kit

The tools supplied are necessary for performing some periodic maintenance, simple adjustments and repairs.

Always keep the kit with the tractor.

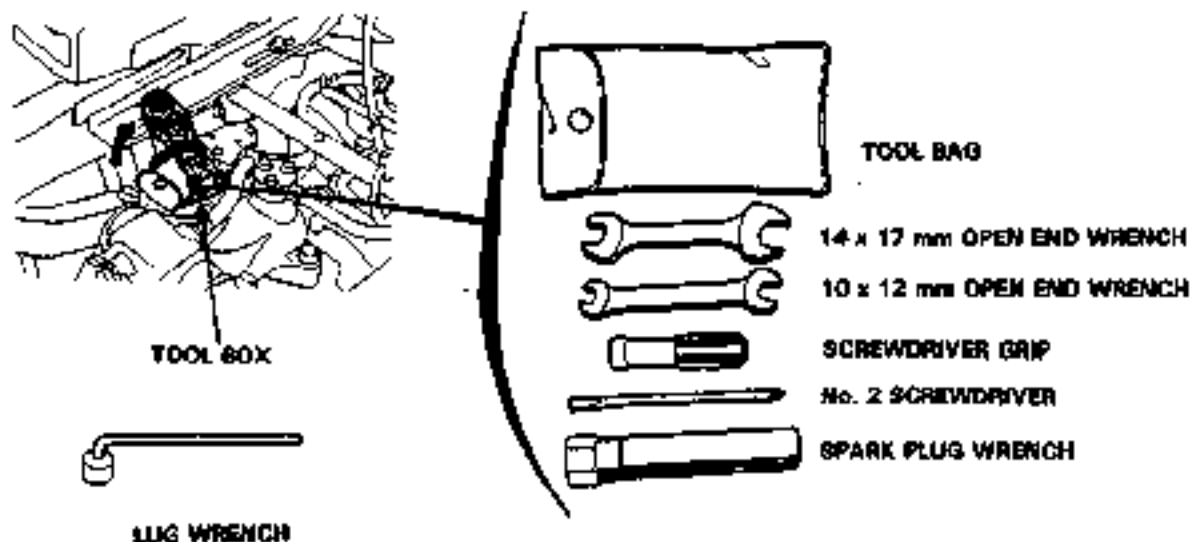

## 2. Maintenance Schedule

REGULAR SERVICE PERIOD		EACH USE	FIRST 20 HRS	EVERY 50 HRS	EVERY 100 HRS	EVERY YEAR OR 300 HRS	REFER TO PAGE
ITEM	Perform at every indicated month or operating hour interval, whichever comes first.						
Engine oil	Check level Change	○	○		○		28 53
Hydraulic lift system	Check	○					
Oil level and oil leakage	Check	○					29-33
Battery electrolyte	Check level	○					35
Air cleaner	Check Clean	○		○ (1)			27 64
Cooling air intake	Clean	○					28
Engine fins and shroud	Check-clean	○					27
Interlock system operation	Check	○					
Seat switch, front P.T.O. clutch, rear P.T.O. clutch, main transmission lever							36-40
Parking brake operation	Check	○					37
Tires: nut tightened	Check-Relighten	○ (3)	○	○			
Air pressure, checks, damage, etc.	Check	○					33
Steering wheel free play or looseness	Check	○					34
Headlight	Check	○					37
Front P.T.O. disc	Check	○					30
Front P.T.O. lever free play	Check-Adjust	○					30
Clutch pedal free play	Check Adjust	○				○ (2)	32
Brake pedal free play	Check Adjust	○				○ (2)	
Brake wear indicator	Check	○					31
Brake effectiveness	Check	○					
Differential lock pedal free play	Check Adjust	○				○ (2)	32
Fuel tank	Check leak	○				○ (2)	
Fuel tank and filter	Clean						29
All fasteners (for tightness)	Check-Relighten			○			71
Lubrication points	Oil-Grease			○			71
Transmission oil	Check level				○		70
Spark plug	Check-Clean				○		65
Spark arrester (optional part)	Clean				○		73
Fuel sediment cup	Clean					○	70
Wiring: terminals, clamps, insulation etc.	Check					○ (2)	-
Engine rpm	Check-Adjust					○ (2)	-
Valve clearance	Check-Adjust					○ (2)	-
Tie-rods (for bending), ball-joints (for looseness)	Check-Adjust					○ (2)	-
Tie-in	Check-Adjust						
Rust treat	Check Repaint if necessary						Every 3 years (2)

NOTE: (1) Service the air cleaner more frequently when used in dusty areas.

(2) These items should be serviced by an authorized Honda tractor dealer, unless the owner has proper tools and is mechanically proficient. See the Honda Shop Manual.

(3) Check the nuts daily for the first 20 hours of operation, and relighten if necessary.

### 3. Engine oil change

**NOTE:** Drain the oil while the engine is still warm to assure rapid and complete draining.

1. Open the engine hood.
2. Remove the oil filler cap and the drain plug, and drain the oil into a suitable container.
3. Retighten the drain bolt securely.
4. Refill to the upper level mark on the dipstick with the recommended oil (see p.26). Tighten the oil filler cap securely.

**NOTE:** Do not screw the dipstick in when checking the oil level.

**OIL CAPACITY: 1.15 l (1.2 US qt)**

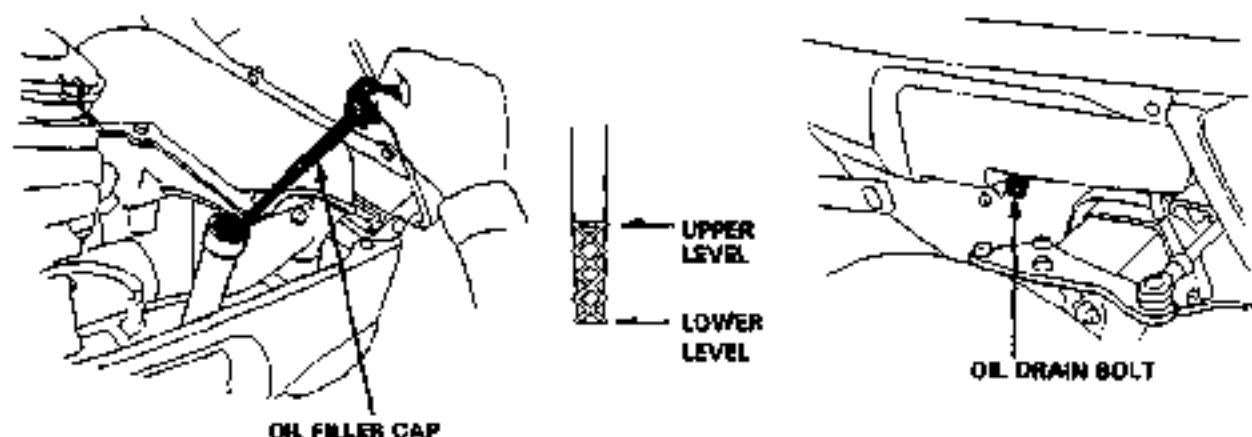

**CAUTION:** Used motor oil may cause skin cancer if repeatedly left in contact with the skin for prolonged periods. Although this is unlikely unless you handle used oil on a daily basis, it is still advisable to thoroughly wash your hands with soap and water as soon as possible after handling used oil.

**NOTE:** Please dispose of used motor oil in a manner that is compatible with the environment. We suggest you take it in a sealed container to your local service station for reclamation. Do not throw it in the trash or pour it on the ground.



#### 4. Air cleaner service

A dirty air cleaner will restrict air flow to the carburetor. To prevent carburetor malfunction, service the air cleaner regularly. Service more frequently when operating the tractor in extremely dusty areas.

**Warning** Never use gasoline or low flash point solvents for cleaning the air cleaner element. A fire or explosion could result.

**CAUTION:** Never run the engine without the air cleaner. Rapid engine wear will result.

1. Open the engine hood.
2. Remove the wing nuts and the air cleaner cover. Remove the elements and separate them. Carefully check both elements for holes or tears and replace if damaged.
3. Foam element: Clean in warm soapy water, rinse and allow to dry thoroughly. Or clean in high flash-point solvent and allow to dry. Dip the element in clean engine oil and squeeze out all the excess. The engine will smoke during initial start-up if too much oil is left in the foam.
4. Paper element: Tap the element lightly several times on a hard surface to remove excess dirt, or blow compressed air through the filter from the inside out. Never try to brush the dirt off; brushing will force dirt into the fibers.

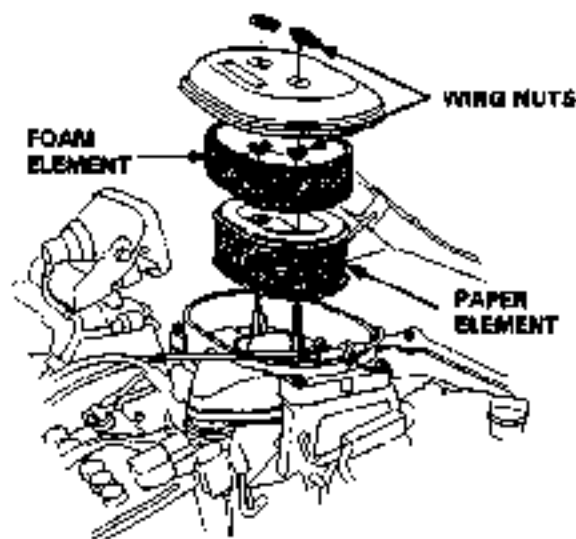

## 5. Spark plug service.

**Recommended spark plug: BPR6ES-11 (NGK)  
W20EPR-U11 (ND)**

To ensure proper engine operation, the spark plug must be properly gapped and free of deposits.

1. Remove the spark plug cap.
2. Clean any dirt from around the spark plug base.
3. Use a spark plug wrench to remove the spark plug.

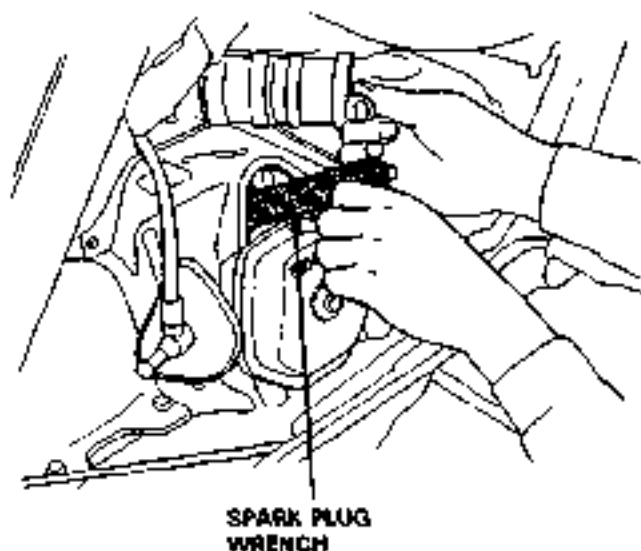

4. Visually inspect the spark plug. Discard it if there is apparent wear or if the insulator is cracked or chipped. Clean the spark plug with a wire brush if it is to be reused.
5. Measure the plug gap with a feeler gauge. The gap should be 1.0 – 1.1 mm (0.039 – 0.043 in). Correct as necessary by carefully bending the side electrode.

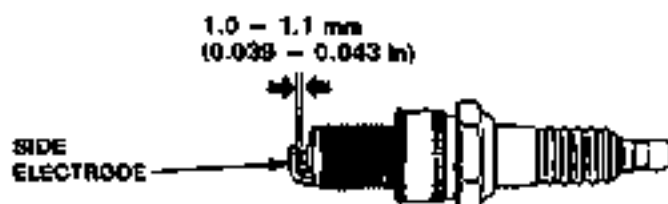

---

6. Thread the plug in by hand to prevent cross threading.

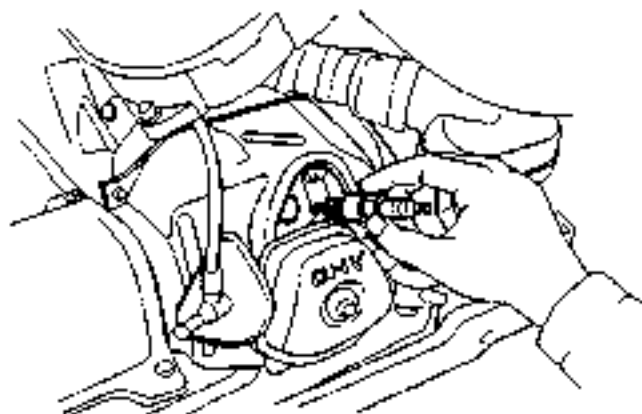

7. After a new spark plug has been seated by hand, it should be tightened 1/2 turn with a wrench to compress its washer.  
If a used plug is being reinstalled, it should only require 1/8 to 1/4 turn after being seated.

**CAUTION:**

- The spark plug must be securely tightened. An improperly tightened plug can become very hot and possibly damage the engine.
- Never use a spark plug with an improper heat range.

## 6. Battery service

### ■ Refilling battery fluid

Open the engine hood and check the electrolyte level in each battery cell. If the electrolyte level is low, disconnect the negative (-) cable from the battery first, then disconnect the positive (+) cable. Remove the battery set plate and remove the battery. Remove the battery filler caps and carefully add distilled water to the upper level mark, using a small syringe or plastic funnel.

#### CAUTION:

- If the battery is used or stored with insufficient battery electrolyte, sulfation and battery plate damage will occur.
- If rapid loss of electrolyte is experienced, or if your battery seems to be weak, causing slow starting or other electrical problems, consult your authorized Honda tractor dealer.

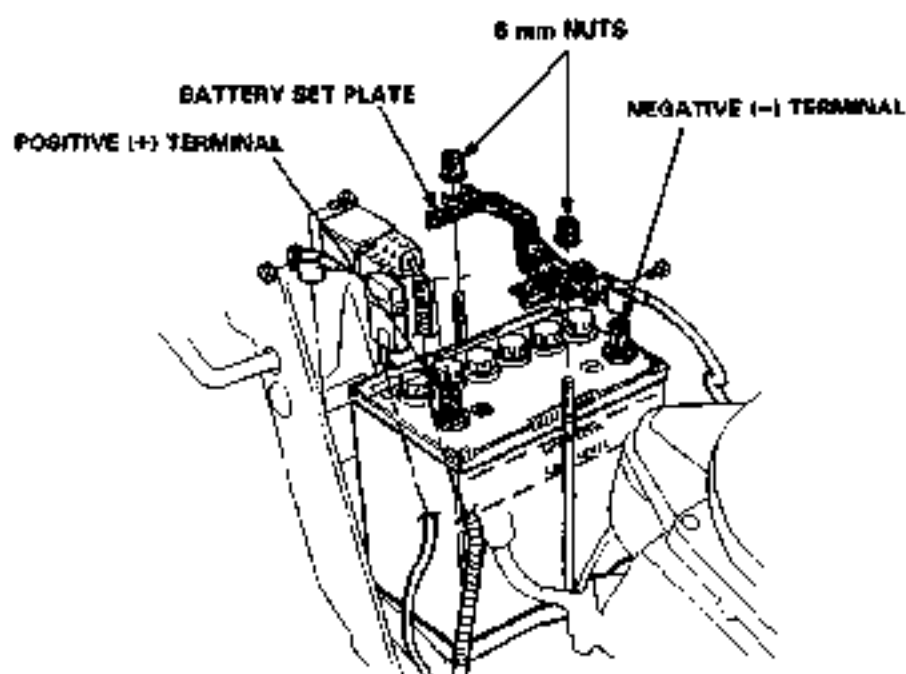

#### **CAUTION:**

- The battery gives off explosive gases; keep sparks, flames and cigarettes away. Provide adequate ventilation when charging or using batteries in an enclosed space.
- The battery contains sulfuric acid (electrolyte). Contact with skin or eyes may cause severe burns. Wear protective clothing and a face shield.
  - If electrolyte gets on your skin, flush with water.
  - If electrolyte gets in your eyes, flush with water for at least 15 minutes and call a physician immediately.
- Electrolyte is poisonous.
  - If swallowed, drink large quantities of water or milk and follow with milk of magnesia or vegetable oil and call a physician.
- **KEEP OUT OF REACH OF CHILDREN.**

#### **CAUTION:**

- Use only distilled water in the battery. Tap water will shorten the service life of the battery.
- Filling the battery above the **UPPER LEVEL** line may cause the electrolyte to overflow, resulting in corrosion to engine or nearby parts. Immediately wash off any spilled electrolyte.

If the battery terminals or cables are contaminated or corroded, clean them with a wire brush or sand paper.

Clean the battery with a solution of baking soda and warm water taking care not to get the solution in the battery cells. Dry the battery thoroughly.

Install the battery to the rear right part of the battery tray, as shown in the figure below.

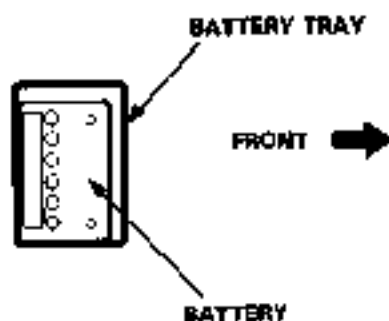

Connect the battery positive (+) cable first then the battery negative (-) cable. Tighten the bolts securely.

---

Coat the battery terminals with grease. Reinstall the battery set plate.

**NOTE:** Evenly tighten the 6 mm set plate nuts a little at a time. Install the set plate so that the filler caps (A and B) to either side of it can still be removed.

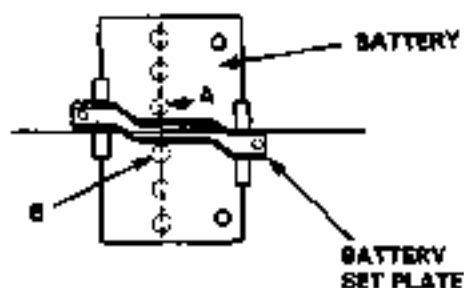

**CAUTION:** Always disconnect the negative cable first and reconnect it last. This will reduce the chance of short circuit damage to the battery or other components when working near the battery with tools.

## 7. Fuel sediment cup cleaning

### CAUTION

- Gasoline is extremely flammable and explosive under certain conditions. Do not smoke or allow flames or sparks in the area.
- After cleaning, check that there is no gasoline leakage.

1. Remove the cup holder with a wrench and remove the fuel filter cup.
2. Clean the filter cup to remove sediment.
3. Reinstall the O-ring, filter cup and cup holder securely.

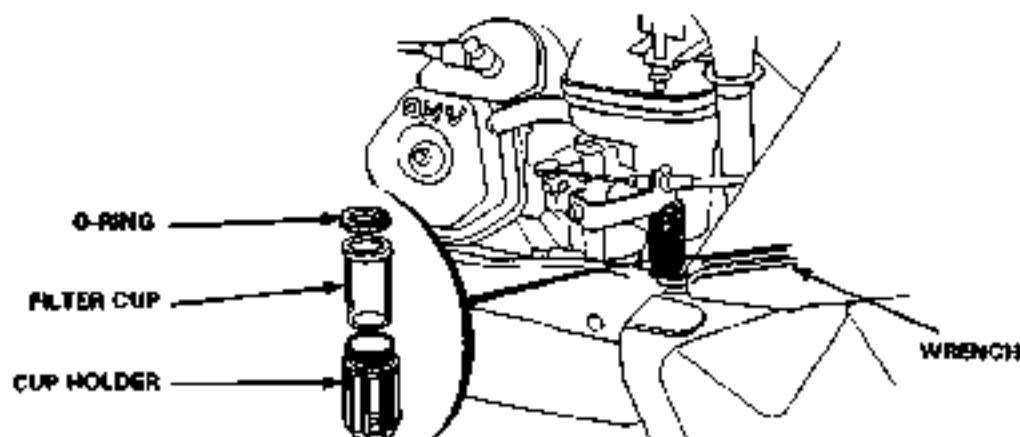

## 8. Transmission oil inspection.

**CAUTION:** Contaminated or insufficient oil will reduce the service life of the tractor's transmission. Follow the instructions for maintenance interval and oil capacity.

1. Park the tractor on level ground.
  2. Remove the oil check bolt from the transmission rear cover.
  3. The oil level should be at the lower edge of the check bolt hole; if it is not, add oil through the check bolt hole until the level reaches the lower edge.
  4. After checking, tighten the oil check bolt securely.
- Recommended oil: 10W-40

**NOTE:** If the outside temperature is below  $-15^{\circ}\text{C}$ , use SAE 5W-30 engine oil. Consult your authorized Honda dealer if replacement of the transmission oil is necessary.

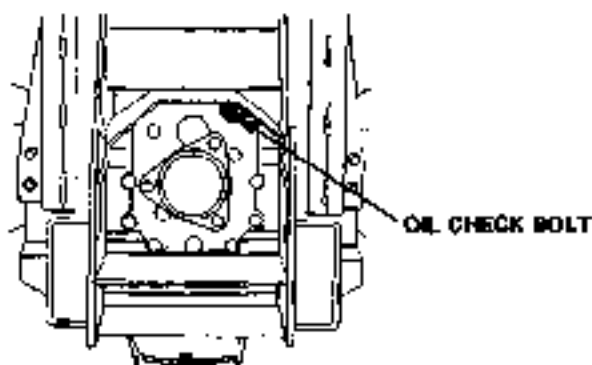

---

## 9. All fasteners tightness/Lubrication points

- Check all nuts, bolts and fasteners and tighten securely if necessary.
- Check and apply grease where noted.  
Recommended Grease: SAE Multipurpose Grease

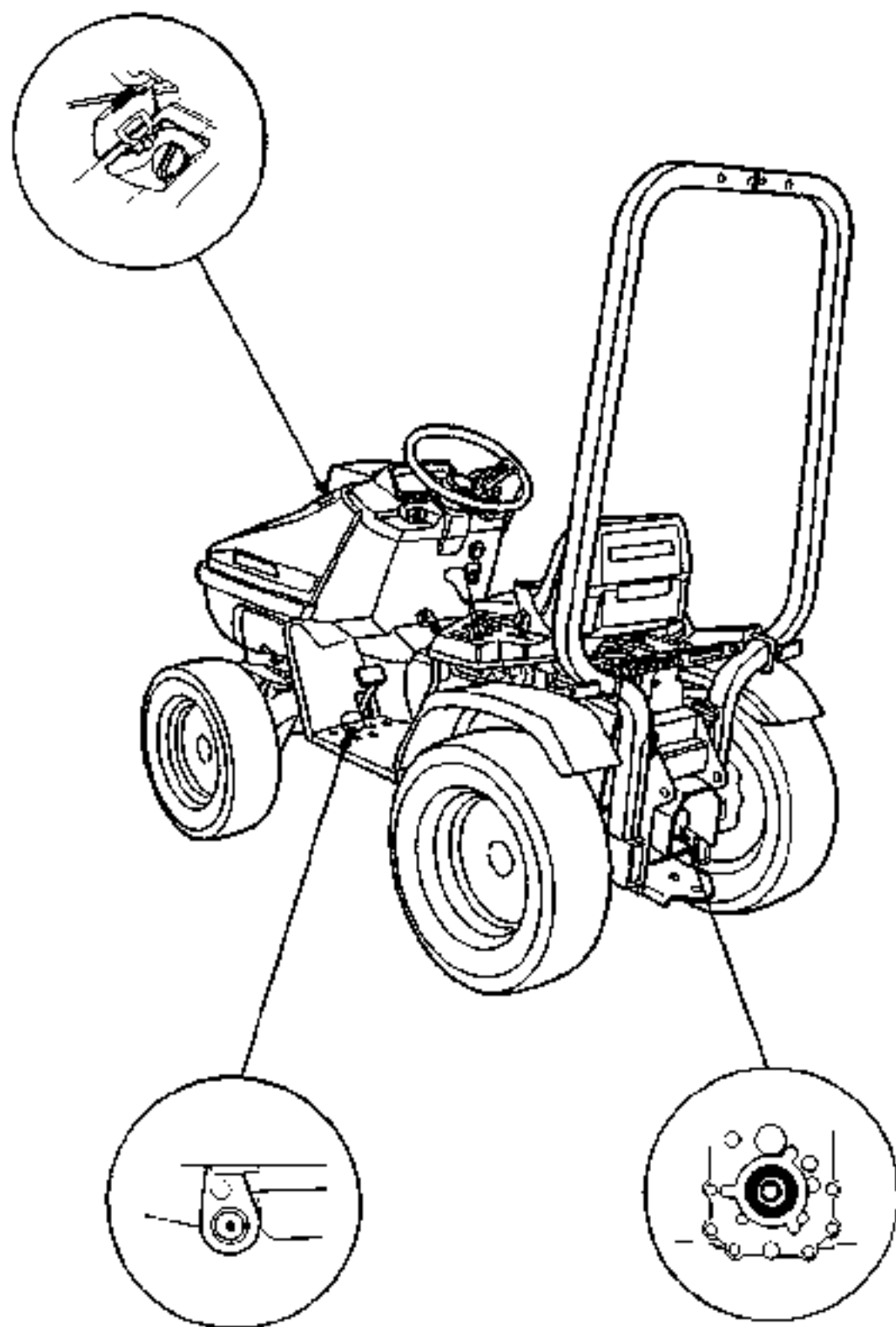



---

### Lubrication points (cont'd)

Check and apply grease where noted.

Recommended grease: SAE Multipurpose Grease.

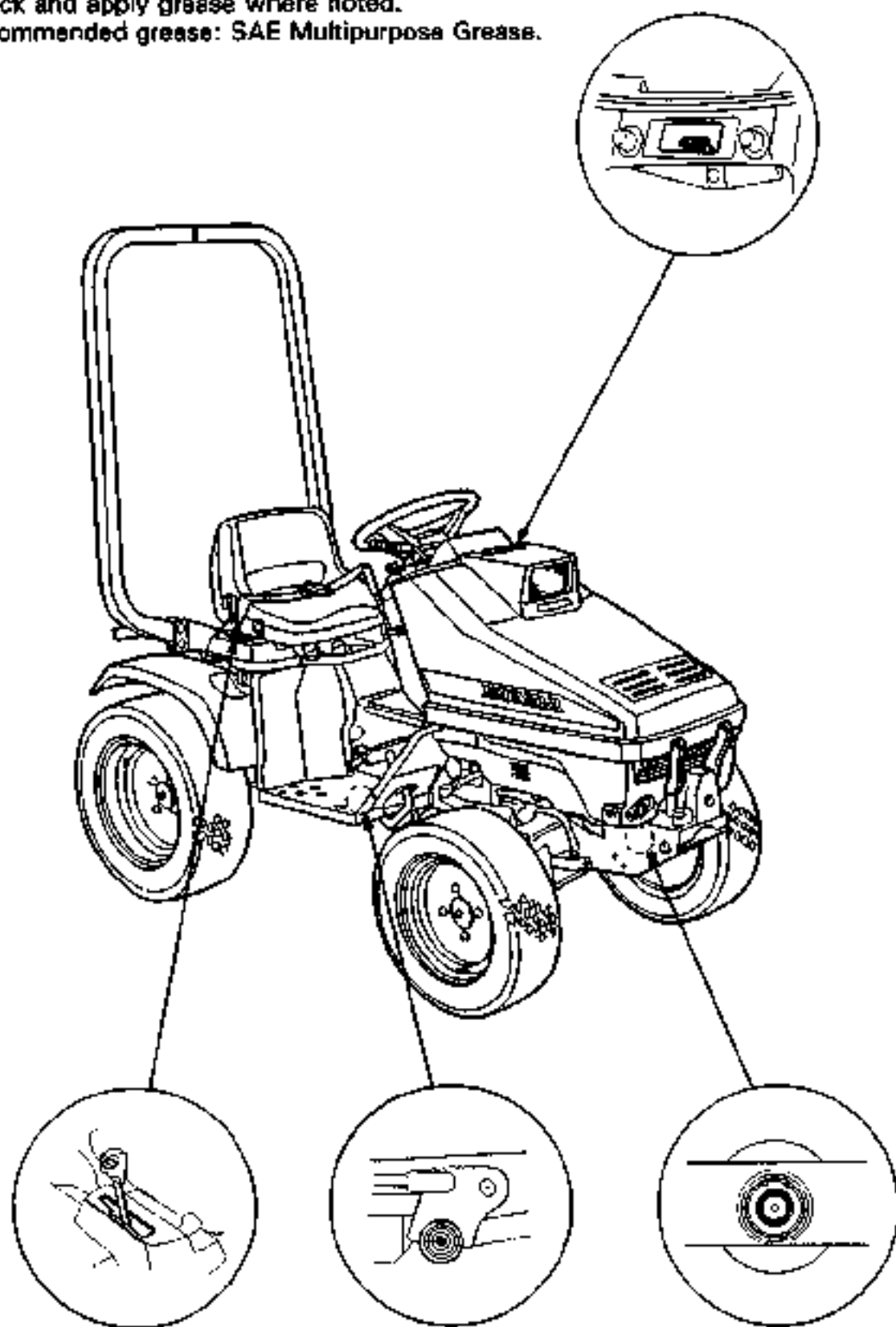

## 10. Spark arrester maintenance (optional part)

You can purchase an optional, U.S.D.A. qualified spark arrester from your authorized Honda tractor dealer. Spark arresters are required in some areas; check local laws and regulations before operating your tractor.

**WARNING:** The muffler becomes very hot during operation and remains hot for a while after the engine stops. Be careful not to touch the muffler while it is hot. Allow it to cool before proceeding.

**CAUTION:** The spark arrester must be serviced every 100 hours to maintain its efficiency.

1. Remove the two 5 mm screws from the exhaust pipe tip. Remove the exhaust pipe tip and spark arrester (be careful not to damage the spark arrester screen).
2. Use a wire brush to remove carbon deposits from the spark arrester screen.

**NOTE:** Inspect the spark arrester, and replace it if the screen is broken or torn.

3. Reinstall all parts in the reverse order of removal.

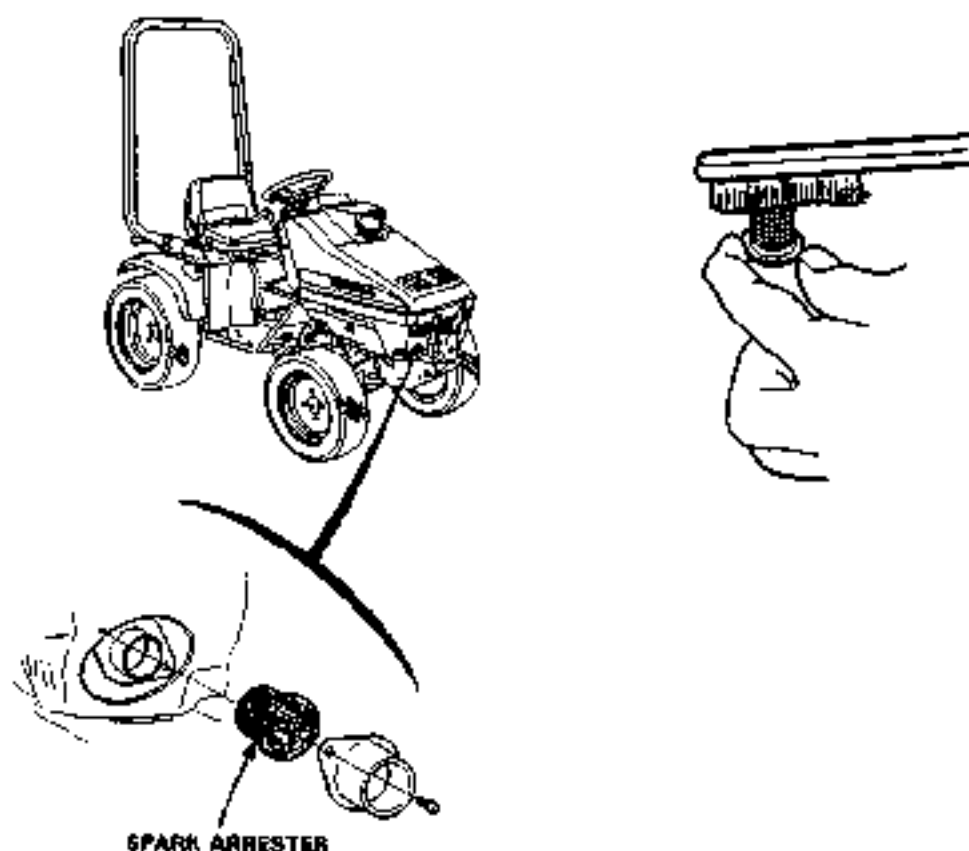

## 11. Wheel removal

### ⚠️ WARNING

- Do not attempt to remove a wheel unless the tractor is on firm level ground.
  - Do not attempt to remove or replace a tire unless you have the equipment and knowledge to do so properly.
1. Apply the parking brake and put the transmission in gear.
  2. Block the wheels securely and loosen the lug nuts counterclockwise one turn.
  3. Place a jack under the jack point nearest the wheel you are removing and raise the wheel off the ground.
  4. Remove the nuts and wheel.
  5. Install the wheel and hand-tighten; reinstall the nuts.
  6. Lower the tractor, remove the jack, and then tighten the nuts a little at a time in an "X" pattern.

Specified torque: 13 kg-m (94 ft-lb)

### [JACK POINTS]

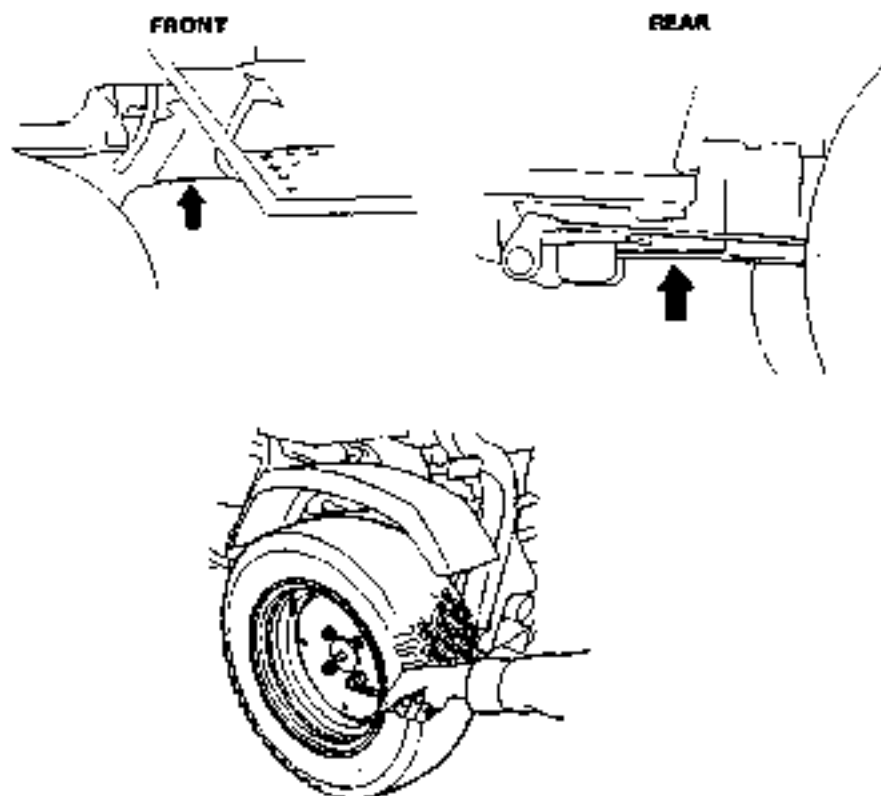

## 12. Fuse replacement

The main fuse, located near the battery on the positive is 20A. The fuse box is located on the right side of the head light case. The specified fuses are 7.5A. When frequent fuse failure occurs, it usually indicates a short circuit or an overload in the electrical system. See your authorized Honda tractor dealer for repair.

To replace fuses pull the old fuse out of the clips with your finger. Push a new fuse into the clips.

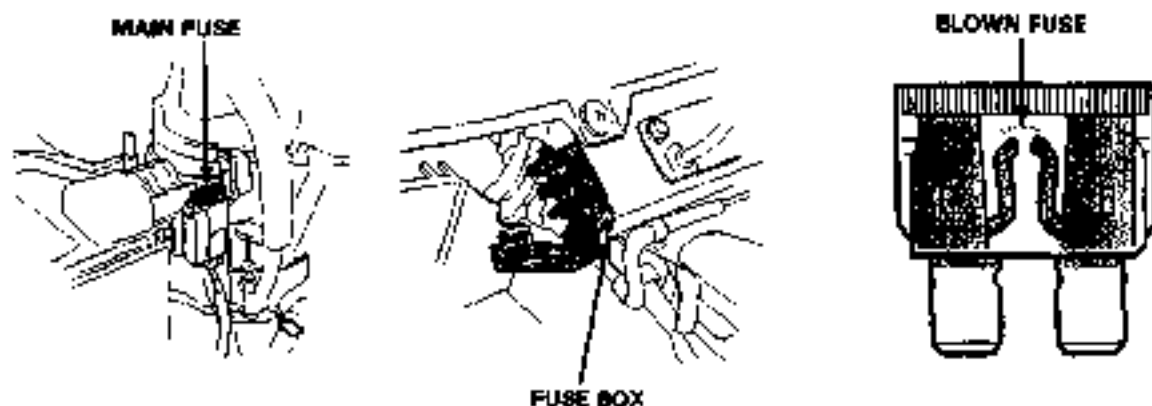

**WARNING** Never use a fuse with a different rating from that specified. Serious damage to the electrical system or a fire may result.

**CAUTION:** Turn the engine switch OFF and remove the key before checking or replacing fuses to prevent accidental short-circuiting.

---

### 13. Headlight bulb replacement

Open the engine hood and lift up the edge of the bulb connector rubber cover. Push in and turn the bulb connector counterclockwise, then remove the connector and bulb.

Install the bulb, and then align the tab on the bulb connector with the cutout in the headlight case. Turn the bulb connector clockwise while pushing it in, and then fit the rubber cover down over the connector.

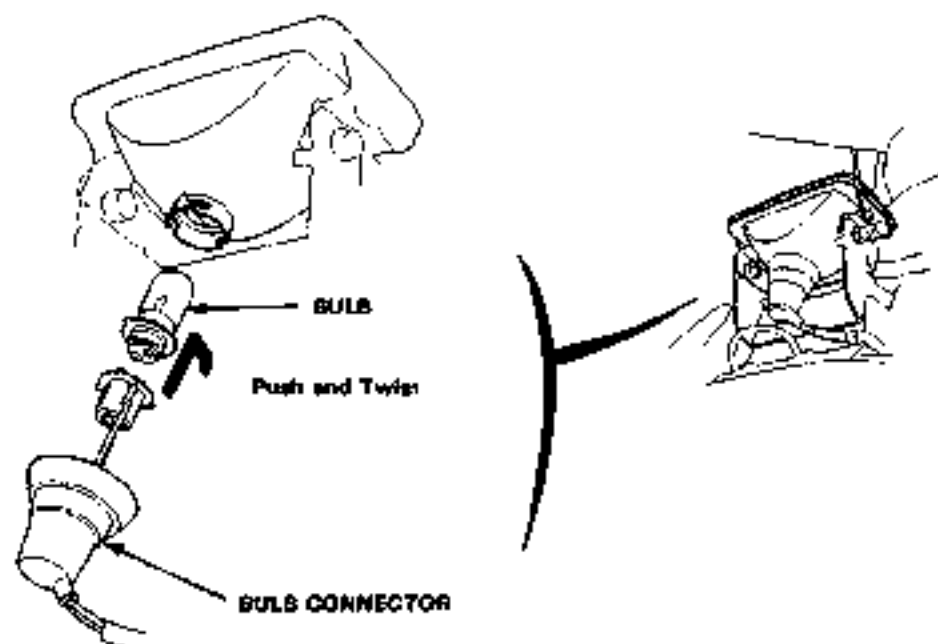

### Preparation for storage

**CAUTION:** Never store the equipment with gasoline in the tank inside a building where fumes may reach an open flame or spark.

**CAUTION:** If the tractor has been running, the engine will be very hot; allow to cool before proceeding.

The following steps should be taken to protect the tractor whenever it will be stored for longer than 30 days.

1. Drain all gasoline from the fuel tank into an approved gasoline container, using a hand siphon pump or equivalent.

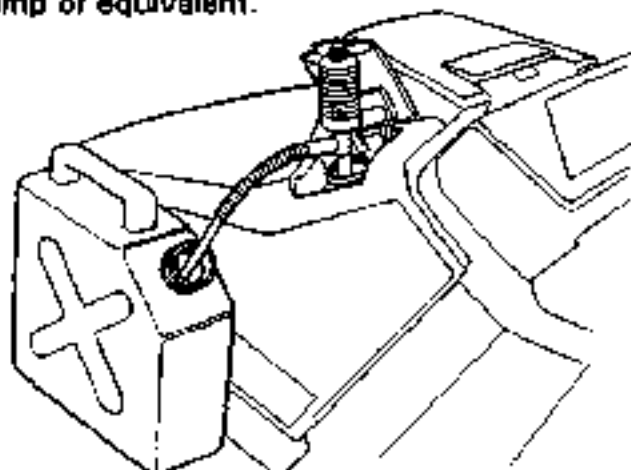

Drain fuel from the fuel sediment cup as described in page 70 and loosen the carburetor drain screw, and drain the fuel into an approved gasoline container. After draining, tighten the drain screw securely.

**CAUTION:** Gasoline is extremely flammable and explosive under certain conditions. Do not smoke or allow flames or sparks in the area.

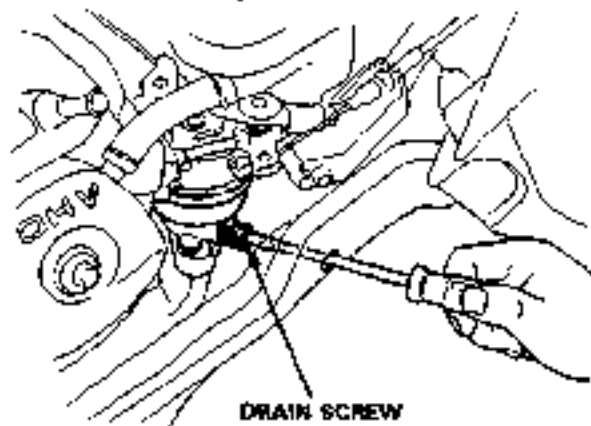

2. Change the engine oil (see p. 63).

**NOTE:** If the tractor will be stored for longer than 3 months, open the engine hood, remove the spark plug and pour three tablespoons (approximately 1 oz.) of clean motor oil into the cylinder. Then reinstall the spark plug.

- 
- Remove the battery and store in a cool, dry place. Recharge it once a month.
  - Store the tractor on a level surface in a dry, dust-free area with the parking brake lever set.
  - Cover the tractor to keep out dust.
  - Check tire air pressure regularly during storage and inflate if necessary.

#### **Removal from storage**

1. Check the battery electrolyte level (see p. 28). Fully recharge the battery, and install it in the tractor.
2. Remove the spark plug and check that it is clean and properly gapped (see p. 65). Turn the engine a few revolutions with the starter motor before reinstalling the spark plug.
3. Thread the spark plug in as far as possible by hand, then tighten it 1/8 to 1/4 turn further with the plug wrench.
4. Check the engine oil level (see p. 26).
5. Fill the fuel tank, and start the engine by following the starting instructions (see p. 43).

**NOTE:** If the cylinder was coated with oil, the engine will initially smoke at start up; this is normal.

# 11. WIRING DIAGRAM

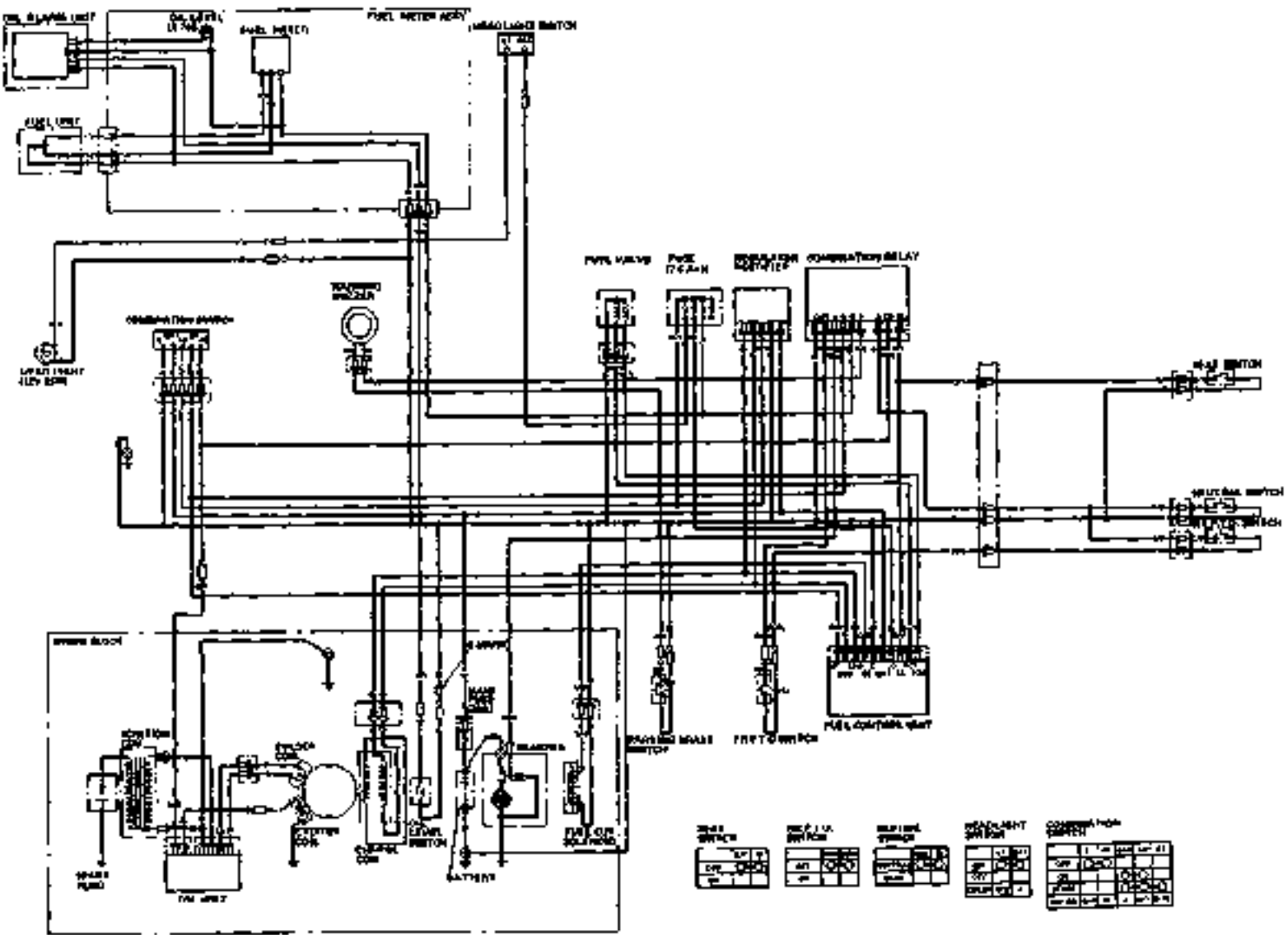



## 12. TROUBLESHOOTING

---

### STARTER

- Starter does not work;
  1. Main transmission shift lever set in → Shift lever in "N" other than NEUTRAL.
  2. Front or rear PTO clutch lever set in → Set lever in "OFF" ON.
  3. Loose or corroded battery terminal → Retighten or clean (see p.67)
  4. Blown fuse → Replace (see p.75)
  5. Battery run down → See your authorized Honda dealer

### ENGINE

- Engine cranks but won't start;
  1. No fuel in tank → Refill tank (see p.35)
  2. Choke not pulled out when engine is cold → Pull out choke
  3. Disconnected spark plug cap → Reinstall cap
  4. Faulty plug → Clean or replace (see p.65)
  5. Blown fuse → Replace (see p.75)
  6. Faulty fuel cut solenoid valve (fuel not getting to carburetor) → See your authorized Honda dealer
- Engine lacks power;
- Unstable engine rpm;
- Stalling after starting;
- Overheating;
  1. Improper grade of fuel → Drain residual fuel and refill (see p.36)
  2. Front PTO clutch out of adjustment (not disengaged completely) → See your authorized Honda dealer
  3. Throttle cable not adjusted properly → See your authorized Honda dealer
  4. Governor not adjusted properly → See your authorized Honda dealer
  5. Carburetor faulty → See your authorized Honda dealer
  6. Ignition system faulty → See your authorized Honda dealer
  7. Fuel filter clogged → See your authorized Honda dealer
  8. Air cleaner clogged → Clean (see p.64)
  9. Faulty spark plug → Clean or replace (see p.65)
  10. Improper governer operation → See your authorized Honda dealer

- 11. Incorrect valve clearance → See your authorized Honda dealer
  - 12. Improper grade of fuel → Drain residual fuel and refill (see p.35)
  - 13. Improper attachment → Replace with recommended attachment
  - 14. Extreme weather/barometric conditions (altitude, temperature) → See your authorized Honda dealer
  - 15. Parking brake not released fully → Release fully
  - 16. Brake dragging → See your authorized Honda dealer
  - 17. Excessive load → Reduce load or speed
  - 18. Clogged air intake or shroud → Clean (see p.27)
- Excessive oil consumption
    - 1. Improper oil viscosity → Use correct viscosity of oil (see p.26)
    - 2. Oil leak → Check drain plug for tightness
    - 3. Worn piston ring/cylinder → See your authorized Honda dealer

## **ELECTRICAL SYSTEM**

- Battery runs down frequently
  - 1. Loose or corroded battery terminal → Clean or retighten (see p.67)
  - 2. Low electrolyte level → Add distilled water (see p.67)
  - 3. Damaged battery cell → Replace battery
  - 4. Faulty battery charging coil → See your authorized Honda dealer
- Oil pressure warning lamp remains "ON" after engine is started
  - 1. Lack of oil in engine oil pan → Replenish oil
  - 2. Faulty oil alert → See your authorized Honda dealer
- Oil pressure warning lamp not turned "ON" immediately after engine starts
  - 1. Blown lamp bulb → See your authorized Honda dealer
  - 2. Blown fuse → Replace (see p.75)
  - 3. Faulty oil alert → See your authorized Honda dealer
- Headlight not turned ON
  - 1. Blown light bulb → Replace (see p.76)
  - 2. Ignition key not turned to ON → Turn ignition key to ON
  - 3. Blown fuse → Replace (see p.75)
- Parking brake warning buzzer not operated
  - 1. Blown fuse → Replace (see p.75)
  - 2. Faulty buzzer → See your authorized Honda dealer
- Fuel gauge not operated
  - 1. Blown fuse → Replace (see p.75)
  - 2. Faulty gauge → See your authorized Honda dealer

## **BRAKES**

- ◆ Poor brake performance
  - 1. Clutch pedal not depressed → Apply brake while depressing clutch pedal
  - 2. Excessive brake pedal play → See your authorized Honda dealer
  - 3. Brake linings worn → See your authorized Honda dealer
  - 4. Excessive inertia/weight of attachment → Use correct attachment in correct manner
- ◆ Brake applied only on one side
  - 1. Incorrect brake adjustment → See your authorized Honda dealer
  - 2. Brake pedal shaft sticking → Apply grease
  - 3. Uneven tire pressure → Inflate tires to correct pressure (see p.33)

## **CLUTCH**

- ◆ Clutch not disengaged, Clutch not engaged
  - 1. Improper clutch adjustment → See your authorized Honda dealer
  - 2. Clutch discs worn → See your authorized Honda dealer

## **STEERING**

- ◆ Hard steering
  - 1. Insufficient tire pressure → Inflate tires to correct tire pressure (see p.33)
  - 2. Differential lock applied → Release lock
  - 3. Excessive weight of attachment → Follow attachment weight recommendation (see p.47)
  - 4. Uneven weight distribution → Adjust with counterweights (see p.50)
  - 5. Load towed too heavy → Follow weight limit recommendations (see p.49)
- ◆ Steers to one side or does not track straight
  - 1. Incorrect brake adjustment → See your authorized Honda dealer
  - 2. Incorrect front-end alignment → See your authorized Honda dealer
  - 3. Uneven tire pressures → Inflate tires to correct pressure (see p.33)
  - 4. Loose fasteners in steering linkage → See your authorized Honda dealer
  - 5. Loose wheel nuts → Retighten to specified torque (see p.33)

## **DIFFERENTIAL LOCK**

- ◆ Differential lock not applied
  - 1. Improper pedal play → See your authorized Honda dealer
  - 2. Power not transmitted to wheels → Shift into LOW speed, engage clutch, and then depress pedal
- ◆ Differential lock not released
  - 1. Load from wheels applied to differential lock → Drive in opposite direction a little to release load from differential lock

## FRONT P.T.O.

- PTO does not rotate (or rotates too slowly)
  1. Primary belt broken → See your authorized Honda dealer
  2. Insufficient primary belt tension → See your authorized Honda dealer
  3. Incorrect clutch lever free play → Adjust (see p.30)
  4. Clutch lining worn → See your authorized Honda dealer
  5. Clutch cable cut off → See your authorized Honda dealer

## REAR P.T.O.

- PTO does not rotate
  1. PTO lever not set in ON → Set lever in ON
- PTO cannot be installed
  1. Foreign matter on shaft splines → Clean and apply grease (see p.71)
  2. Shaft not inserted into PTO sufficiently → Insert fully (see p.57)
- PTO lever will not shift into ON (gear noise heard)
  1. Clutch pedal not depressed → Depress clutch pedal before shifting
  2. Attachment still coasting due to inertia → Bring attachment to complete stop before shifting

## HYDRAULIC LIFT

- Lift arm does not raise (or raises slowly)
  1. Change lever not shifted into FRONT or REAR fully → Set in FRONT or REAR securely
  2. Insufficient fluid in system → Replenish (see p.33)
  3. Loss of fluid → See your authorized Honda dealer
  4. Descending speed adjusting knob closed → Adjust speed (see p.24)
  5. Load on lift arm exceeding limits → Follow load limit recommendations (see p.48)
  6. Faulty hydraulic valve or pump → See your authorized Honda dealer
- Lift arm lowered by its own weight
  1. Lack of fluid in system → Replenish (see p.33)
  2. Lift lever not set in NEUTRAL → Set lever in NEUTRAL
  3. Loss of fluid → See your authorized Honda dealer
  4. Faulty hydraulic control valve → See your authorized Honda dealer

- 
- ◆ Lift arm does not lower (or lowers slowly)
    1. Cylinder change lever not set fully → Set in securely in FRONT or REAR
    2. Descending speed adjusting knob closed → Adjust speed (see p.24)
    3. Load not imposed on lift arm → Set lift lever in DOWN, and press down on lift arm by hand
    4. Faulty hydraulic control valve → See your authorized Honda dealer

## 13. SPECIFICATIONS

MODEL Power product description code	RT5000 Honda FA2A
<b>DEMENSION</b> Overall length Overall width Overall height Ground clearance Wheelbase Wheel tread (Front) (Rear) Dry weight	2,080 mm (81.9 in) 1,060 mm (41.7 in) 1,940 mm (76.4 in) with R.O.P.S. 150 mm ( 5.9 in) 1,215 mm (47.8 in) 855 mm (33.7 in) 850 mm (33.5 in) 435 kg (959 lbs)
<b>ENGINE</b> Model Type Displacement Bore and stroke Maximum horsepower Oil capacity	GX340 4-stroke, overhead valve, 1 cylinder 337 cm <sup>3</sup> (20.7 cu in) 82 x 64 mm (3.2 x 2.5 in) 11 ps/3,600 r.p.m. 1.15 ℓ (1.2 U.S. qt)
<b>FRAME</b> Brakes  Front tire size, pressure Rear tire size, pressure Steering Fuel tank capacity	Mechanical leading-trailing shoe type brake (rear wheels) 20 x 7.00 - 12.2 PR, 1.0 kg/cm <sup>2</sup> (14.2 psi) 24 x 8.00 - 14.2 PR, 0.8 kg/cm <sup>2</sup> (11.4 psi) Pinion-and-sector four-wheel steering 8.5 ℓ (2.2 U.S. gal)
<b>DRIVE TRAIN</b> Transmission type  Travel speeds (at full 3800 r.p.m.) Forward     1 (L-1) 2 (H-1) 3 (L-2) 4 (H-2) 5 (L-3) 6 (H-3) 7 (L-4) 8 (H-4) Reverse     1 (L-R1) 2 (H-R1) 3 (L-R2) 4 (H-R2)  Transmission oil capacity Front differential oil capacity Final reduction oil capacity	Selective sliding 8 speeds forward and 4 speeds reverse transmission  0.7 km/h (0.4 mile) 1.1 km/h (0.7 mile) 1.5 km/h (0.9 mile) 2.3 km/h (1.4 mile) 3.2 km/h (2.0 mile) 5.1 km/h (3.2 mile) 6.8 km/h (4.2 mile) 10.7 km/h (6.6 mile) 0.8 km/h (0.5 mile) 1.3 km/h (0.8 mile) 1.7 km/h (1.1 mile) 2.7 km/h (1.7 mile)  3.8 ℓ (4.0 U.S. qt) 0.45 ℓ (0.48 U.S. qt) 0.2 ℓ (0.21 U.S. qt)

<b>HYDRAULIC SYSTEM</b>		
Working pressure		90 kg/cm <sup>2</sup> (1,280 psi)
Pump type		Gear pump
Oil Capacity		1.95 ℓ (2.1 U.S.qt)
<b>P.T.O.</b>		
Type	Rear	Dependent of main clutch
	Front	Live independent
Shaft	Rear	ASAE "O" Category INV. spline 1 inch 15 teeth (female)
	Front	INV. spline 1 inch 15 teeth (male)
Speed	Rear	2,000 rpm at engine speed of 3,600 r.p.m.
	Front	2,650 rpm at engine speed of 3,600 r.p.m.
<b>ELECTRICAL</b>		
Battery		12V-30AH 12V-35AH (optional part)
Spark plug		BPR8ES-11 (NGK), W20EPR-U11 (ND)
Headlight		12V-25W
Oil warning indicator		12V-1.7W

## 14. WARRANTY SERVICE

---

### Owner Satisfaction

Your satisfaction and goodwill are important to your dealer and to us. All Honda warranty details are explained in the Distributor's Limited Warranty. Normally, any problems concerning the product will be handled by your dealer's service department. If you have a warranty problem that has not been handled to your satisfaction, we suggest you take the following action:

- Discuss your problem with a member of dealership management. Often complaints can be quickly resolved at that level. If the problem has already been reviewed with the Service Manager, contact the owner of the dealership or the General Manager.
- If your problem still has not been resolved to your satisfaction, contact the Power Equipment Customer Relations Department of American Honda Motor Co., Inc.

American Honda Motor Co., Inc.  
Power Equipment Division  
Customer Service Office  
4900 Marconi Drive  
Alpharetta, GA 30005

We will need the following information in order to assist you:

- Your name, address, and telephone number
- Product model and serial number
- Date of purchase
- Dealer name and address
- Nature of the problem

After reviewing all the facts involved, you will be advised of what action can be taken. Please bear in mind that your problem will likely be resolved at the dealership, using the dealer's facilities, equipment, and personnel, so it is very important that your initial contact be with the dealer.

Your purchase of a Honda product is greatly appreciated by both your dealer and American Honda Co., Inc. We want to assist you in every way possible to assure your complete satisfaction with your purchase.



# HONDA

