

Directions for use of Parts Catalogue

1. Applicable model of machines

All component and option parts used for TM3160 tractors are listed in this parts catalogue.

1) MODEL TYPE

- F..... FOUR WHEEL DRIVE
- M..... MID PTO.
- R..... FRONT/REAR HITCH & ROPS

2) AREA CODE

- E4..... EUROPE

2. Explanation for head paragraph

KEY	PART CODE	DESCRIPTION	S P C	TYPE OF MODEL						I T C	C O L	G R P	REMARKS
				SSM48M	SSM48F	SSM48G	SRM48M	SRM48F	SRM48G				
1	8595-211-001-20	CASE/UPPER	*	1									
1A	8657-201-081-00	CASE/UPPER	*	1			1						
2	8595-211-002-10	CASE/LOWER	*	1			1						
3	V523-100-801-80	PIN	*				1						
4	V211-260-803-00	BOLT, SEMS	*				1						

- ① KEY shows the location of parts diagramed in the illustration.
- ② Parts numbers begin with `V` and `W` are standard parts of the market.
- ③ `LH` and `RH` on the parts name are described against the moving direction of the machine or are described on the condition how to install parts on the machines.
- ④ SPC : The following symbol classifies parts to be used for machines.
 - `*` means standard parts.
 - `T` shows that the parts can be installed as optional parts.
 - `R` shows that the parts can be used as applicable parts to replace originally equipped parts.

- ⑤ Upper column : QTY shows the number of parts to be used for one unit of machine.

`M` is indicated for parts supplied by a meter long.

`ℓ` is indicated for parts supplied by liter.

`AR` is indicated for parts need to be adjusted or regulated.

Lower column : serial number

—229 means serial number up to 229.

230— means serial number 230 and after.

- ⑥ ITC : Interchangeability

`1`...OLD ← NEW

New parts can be used in place of the old parts.

`2`...OLD → NEW

Old parts can be used in place of the new parts.

`3`...OLD →← NEW

Old parts and new parts can not be replaced each other.

- ⑦ COL : Color code

Color is signified with color code number for colored parts.

Please see the color list shown in the next page.

- ⑧ GRP : Parts shown in this column can be replaced by SET parts.

Example : Parts marked ④ can be replaced by parts marked ⑥, and ⑦ for ⑤, so the rest follow in the same alphabetical order.

- ⑨ Remarks

* Other maker's part code number is shown in this column.

* When Fig. No. is shown in the Remark column of SET parts or ASSY parts, each of their component parts are listed in said Fig. No.

3. Color :

The following colors are used color parts.

COLOR CODE	COLOR	SPRAY TYPE CODE NUMBER	PAINTS 4K DRUM	PAINTS 16K DRUM
4 L	NEO BLUE	1300-985-001-10	1300-985-003-00	—————
5 I	SUNSET GRAY	1300-959-001-10	1300-959-003-00	1300-959-004-00
7 F	MIRROR BLACK	1300-954-001-10	1300-954-003-00	1300-954-004-00

NOTE : Color code is signified only for the parts assigned by the maker as color parts.

4. Serial Numbers :

- 1) For engines serial number is stamped on CYLINDER BLOCK ASSY.

Please see Fig. No. 5-1.

- 2) For chassies serial number is shown on the LABEL.

Please see



5. Parts Order

- 1) Parts numbers listed in the parts catalogue are all registered in “ISEKI on-line computer”.
- 2) When you order parts, please make sure of correct numbers.
- 3) When substitute parts is available, the part number ordered will be automatically turned to a new part number.
- 4) Please be sure to use “ISEKI GENUINE PARTS”.

Any other similar parts other than ISEKI parts when used may cause a trouble that makes us unable to repair or guarantee the warrant.

*** Structure Table of Model ***

<p>M O D E L</p> <p>FIG.</p>	<p>T M 3 F F F 1 M M R 6 E R E 0 4 E 4 4</p>										
<p>46</p>	<p>* * *</p>										
<p>47</p>	<p>* * *</p>										
<p>48</p>	<p>* * *</p>										
<p>49</p>	<p>* * *</p>										
<p>50</p>	<p>* * *</p>										
<p>51</p>	<p>* * *</p>										
<p>52</p>	<p>* * *</p>										
<p>53</p>	<p>* * *</p>										
<p>54</p>	<p>* * *</p>										
<p>55</p>	<p>* * *</p>										
<p>56</p>	<p>* * *</p>										
<p>57</p>	<p>* *</p>										
<p>58</p>	<p>* * *</p>										
<p>59</p>	<p>* * *</p>										
<p>60</p>	<p>* * *</p>										
<p>61</p>	<p>* * *</p>										
<p>62</p>	<p>T</p>										
<p>63</p>	<p>TTT</p>										
<p>64</p>	<p>TTT</p>										
<p>65</p>	<p>T</p>										
<p>66</p>	<p>TTT</p>										
<p>67</p>	<p>TTT</p>										
<p>68</p>	<p>T</p>										
<p>69</p>	<p>T</p>										
<p>70</p>	<p>TTT</p>										
<p>71</p>	<p>* * *</p>										
<p>72</p>	<p>* * *</p>										

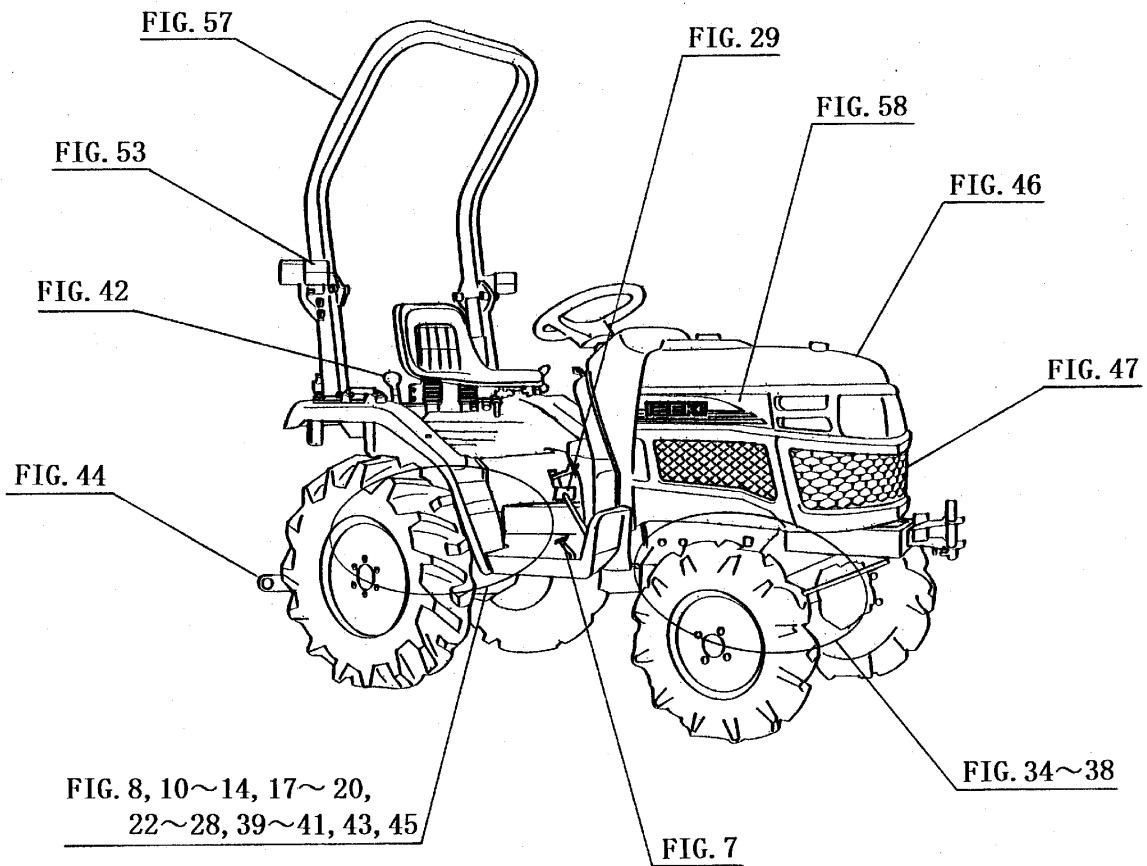
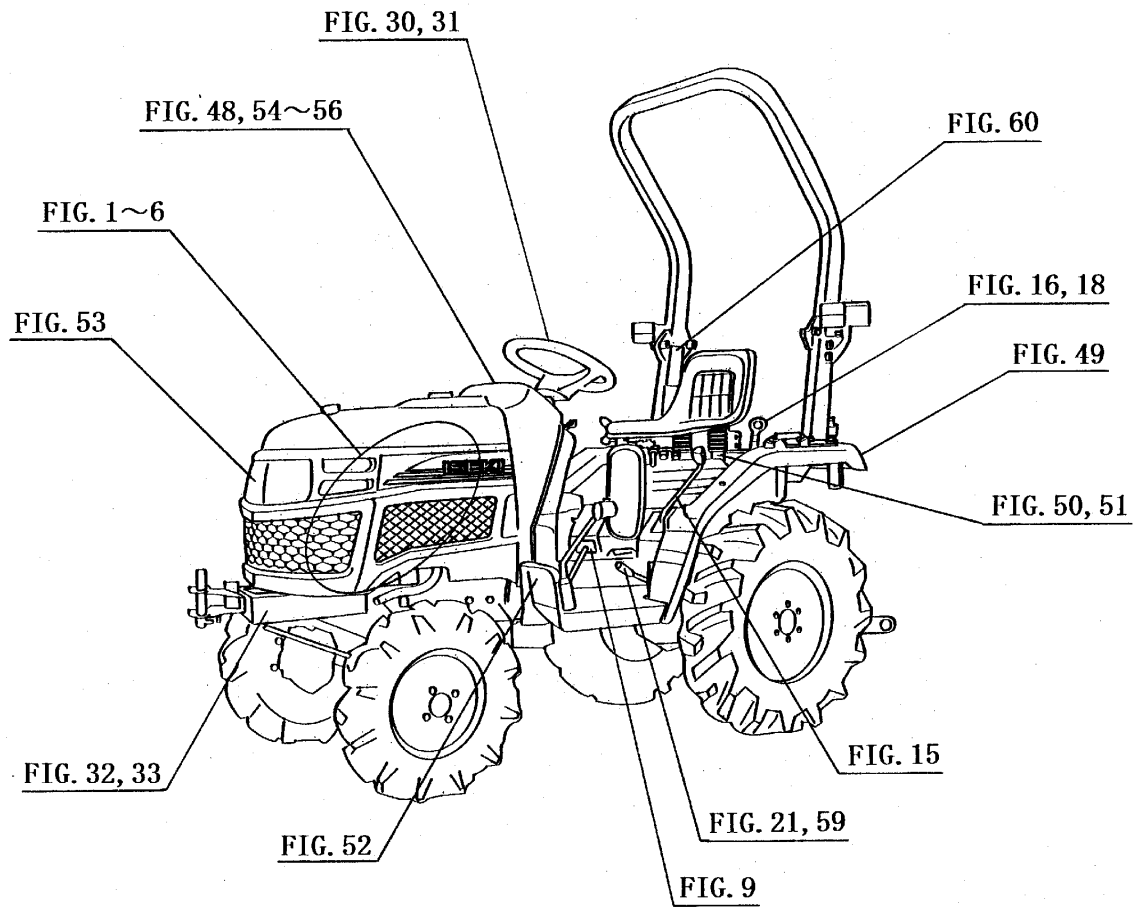

Contents

TM3160

ENGINE(E393B06)

CYLINDER HEAD.....	Fig. 1
CYLINDER HEAD COVER.....	Fig. 2
INLET MANIFOLD.....	Fig. 3
EXHAUST MANIFOLD.....	Fig. 4
CYLINDER BLOCK.....	Fig. 5
BEARING/UNDER SIZE (OPTION).....	Fig. 6
OIL PAN.....	Fig. 7
REAR PLATE.....	Fig. 8
TIMING GEAR CASE.....	Fig. 9
HANGER.....	Fig. 10
VALVE.....	Fig. 11
CAM SHAFT.....	Fig. 12
PISTON.....	Fig. 13
PISTON/OVER SIZE (OPTION).....	Fig. 14
CRANK SHAFT.....	Fig. 15
OIL PUMP.....	Fig. 16
WATER PUMP.....	Fig. 17
COOLING FAN.....	Fig. 18
INJECTION NOZZLE.....	Fig. 19
INJECTION PUMP.....	Fig. 20
FUEL PIPE.....	Fig. 21
ADAPTER.....	Fig. 22
ELECTRIC (1).....	Fig. 23
ELECTRIC (2).....	Fig. 24

REPAIR PARTS (OPTION)..... Fig. 25

COMPONENT PARTS

 FOR 6215-300-037-00 ON Fig.19..... Fig. 26

COMPONENT PARTS

 FOR 6215-600-109-30 ON Fig.20..... Fig. 27

COMPONENT PARTS

 FOR 6281-100-014-00 ON Fig.23..... Fig. 28

COMPONENT PARTS

 FOR 6281-200-007-00 ON Fig.23..... Fig. 29

Contents

CHASSIS

RADIATOR SYSTEM.....	Fig. 1
MUFFLER SYSTEM.....	Fig. 2
AIR CLEANER SYSTEM.....	Fig. 3
FILTER SYSTEM.....	Fig. 4
FUEL TANK SYSTEM.....	Fig. 5
BATTERY SYSTEM.....	Fig. 6
ACCELERATOR SYSTEM.....	Fig. 7
MAIN CLUTCH,INPUT SHAFT SYSTEM.....	Fig. 8
PEDAL (CLUTCH) SYSTEM.....	Fig. 9
CASE (TRANSMISSION) SYSTEM.....	Fig. 10
GEAR (INPUT) SYSTEM.....	Fig. 11
PINION (DRIVE) SYSYTEM.....	Fig. 12
GEAR (REVERSE) SYSTEM.....	Fig. 13
GEAR (4WD) SYSTEM.....	Fig. 14
LEVER (MAIN) SYSTEM.....	Fig. 15
LEVER (SUB) SYSTEM.....	Fig. 16
CHANGE (4WD) SYSTEM.....	Fig. 17
CHANGE (MAIN/SUB) SYSTEM.....	Fig. 18
GEAR (PTO) SYSTEM.....	Fig. 19
SHAFT (PTO) SYSTEM.....	Fig. 20
LEVER (PTO) SYSTEM.....	Fig. 21
SHIELD COVER SYSTEM.....	Fig. 22
MID PTO SYSTEM(1/2)(2/2).....	Fig. 23
DIFF CASE SYSTEM.....	Fig. 24
REAR AXLE HOUSING SYSTEM.....	Fig. 25
SHAFT (WHEEL) SYSTEM.....	Fig. 26
PEDAL (DIFF-LOCK) SYSTEM.....	Fig. 27

BRAKE SYSTEM	Fig. 28
PEDAL (BRAKE) SYSTEM(1/2)(2/2)	Fig. 29
STEERING WHEEL SYSTEM	Fig. 30
STEERING (MANUAL) SYSTEM	Fig. 31
BRACKET (AXLE) SYSTEM	Fig. 32
HITCH (FRONT) SYSTEM (R TYPE)	Fig. 33
SHAFT (DRIVE) SYSTEM	Fig. 34
BEVEL CASE SYSTEM	Fig. 35
AXLE HOUSING SYSTEM	Fig. 36
FINAL GEAR CASE SYSTEM	Fig. 37
TIE ROD SYSTEM	Fig. 38
CASE (CYLINDER) SYSTEM	Fig. 39
LIFT ARM SYSTEM	Fig. 40
CYLINDER SYSTEM	Fig. 41
CONTROL SYSTEM	Fig. 42
PIPING SYSTEM	Fig. 43
LINK (3P) SYSTEM	Fig. 44
HITCH (DRAW BAR) SYSTEM (R TYPE)	Fig. 45
HOOD SYSTEM(1/2)(2/2)	Fig. 46
GRILLE SYSTEM	Fig. 47
STEERING COVER SYSTEM	Fig. 48
FENDER SYSTEM	Fig. 49
SEAT BASE SYSTEM	Fig. 50
FRAME SYSTEM	Fig. 51
STEP SYSTEM	Fig. 52
LAMP SYSTEM	Fig. 53
PANEL SYSTEM	Fig. 54
SWITCH SYSTEM	Fig. 55
HARNESS SYSTEM	Fig. 56
ROPS SYSTEM (R TYPE)	Fig. 57
ORNAMENT, LABEL	Fig. 58
LABEL (CONTROL)	Fig. 59
LABEL (CAUTION)	Fig. 60

TOOLS..... Fig. 61

OPTIONAL PARTS

MID PTO SET (EXCEPT M TYPE)

(OPTION)(1/2)(2/2)..... Fig. 62

REAR WHEEL (TURF) SYSTEM (OPTION)..... Fig. 63

REAR WHEEL SYSTEM (OPTION)..... Fig. 64

HITCH (FRONT) SET (EXCEPT R TYPE)

(OPTION)..... Fig. 65

FRONT WHEEL SYSTEM (OPTION)..... Fig. 66

FRONT WHEEL (TURF) SYSTEM (OPTION)..... Fig. 67

HITCH (DRAW BAR) SET (EXCEPT R TYPE)

(OPTION)..... Fig. 68

ROPS SET (EXCEPT R TYPE) (OPTION)..... Fig. 69

WEIGHT (BUMPER) SYSTEM (OPTION)..... Fig. 70

COMPONENT PARTS

COMPONENT PARTS

FOR K211-001-000-00 ON Fig.41..... Fig. 71

COMPONENT PARTS

FOR 1682-406-210-10 ON Fig.31..... Fig. 72

WIRING DIAGRAM (1)

WIRING DIAGRAM (2)

ENGINE

E393B06...TM3160

FIG. 5 CYLINDER BLOCK

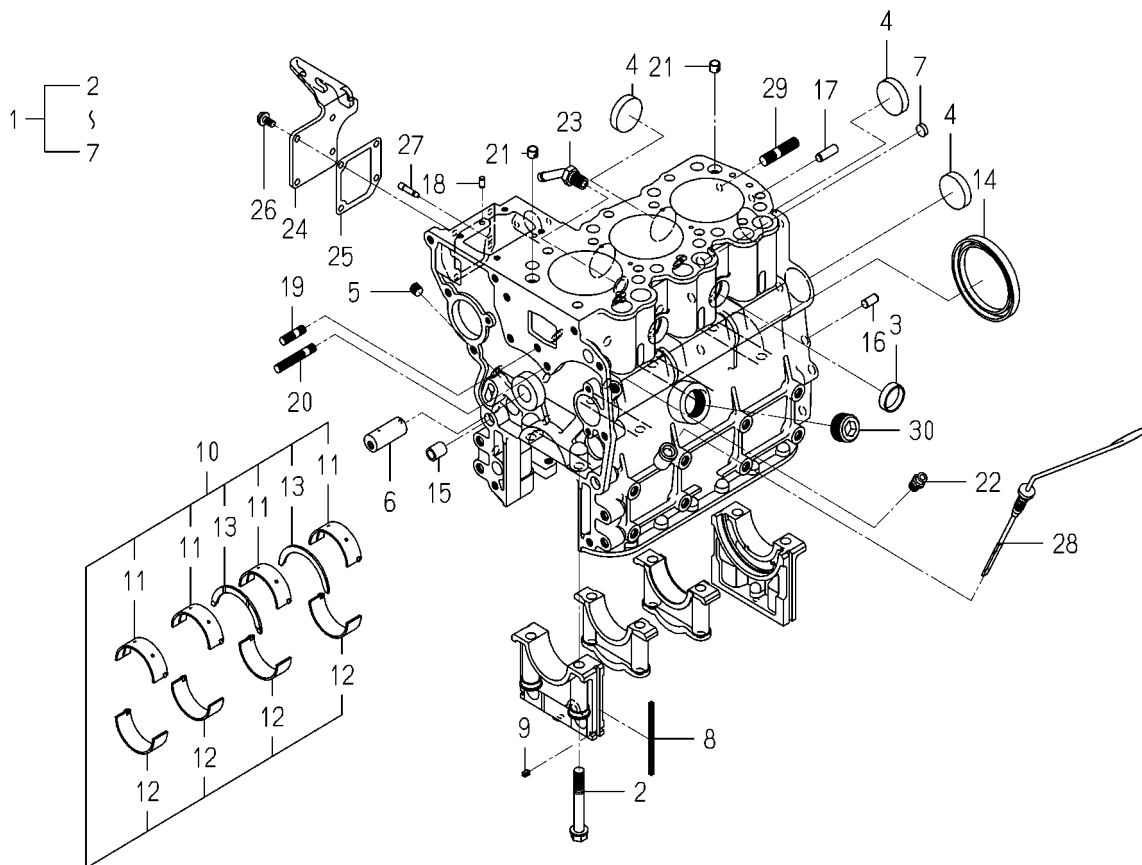

6003-201Y-0100

KEY	PART CODE	DESCRIPTION	S P C	TYPE OF MODEL		I T C	C O L	G R P	REMARKS
				E393B06					
1	6211-210-050-20	CYLINDERBLOCK ASSY	*	1					
2	6209-000-004-10	BOLT	*	8					
3	6209-610-001-10	CUP/SEALING/28	*	2					
4	6209-610-009-00	CUP/SEALING/36	*	4					
5	6509-605-019-10	PLUG	*	3					
6	6212-531-005-10	PIN/IDLEGEAR	*	1					
7	6209-610-008-00	CUP/SEALING/12	*	1					
8	6211-258-001-00	SEAL, BEARING CAP	*	4					
9	6211-258-002-00	SEAL, BEARING CAP/7	*	2					
10	6211-510-001-00	METAL, CRANK SET	*	1					
11	6211-511-003-00	BEARING/CRANK/UPPER	*	4					
12	6211-511-004-00	BEARING/CRANK/LOWER	*	4					
13	6211-599-001-10	BEARING, THRUST CRANK	*	2					
14	6209-625-012-00	OILSEAL	*	1					
15	6209-749-001-20	PIN/TUBE	*	2					
16	6213-129-006-00	PIN/STRAIGHT	*	1					
17	V523-100-802-40	PIN	*	1					
18	6213-129-005-00	PIN/STRAIGHT	*	2					
19	6904-110-818-00	STUD	*	1					
20	6904-110-840-00	STUD/M8X40	*	1					
21	6294-453-002-00	DOWEL	*	2					
22	6909-902-299-00	NIPPLE	*	1					
23	6213-721-007-00	PIPE/WATERDRAIN	*	1					
24	6211-291-016-00	COVER/INJECTIONPUMP	*	1					
25	6211-292-001-20	GASKET/COVER	*	1					
26	V230-360-601-20	FLANGEBOLT	*	4					
27	6215-549-001-10	PIN, STARTING SPRING	*	1					
28	6211-760-012-20	LEVELGAGE	*	1					
29	6209-300-013-00	STUD	*	2					
30	6209-605-005-10	PLUG/PT3/4	*	1					

FIG. 9 TIMING GEAR CASE

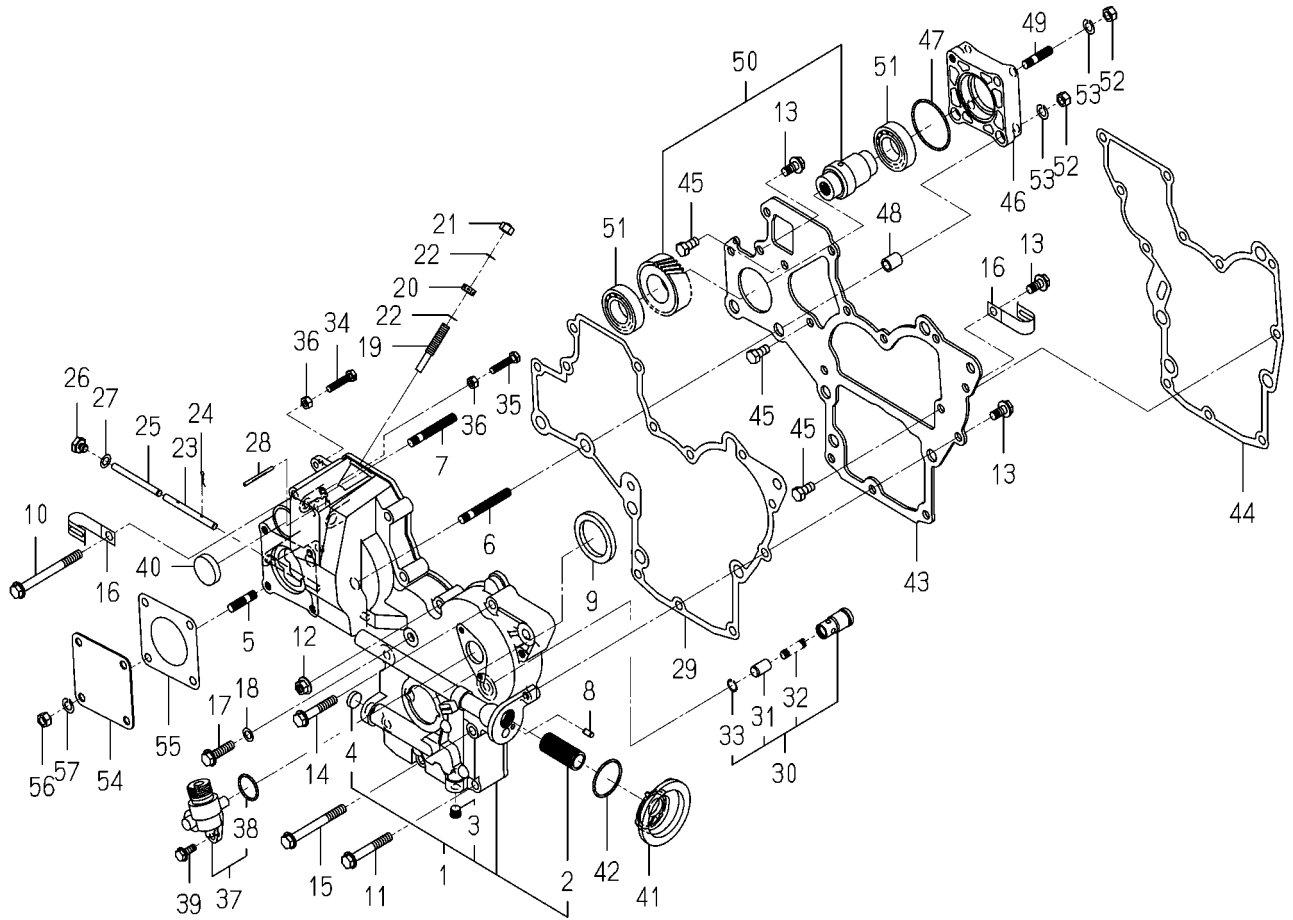

6003-240H-0100,6003-240H-0200

KEY	PART CODE	DESCRIPTION	S P C	TYPE OF MODEL		I T C	C O L	G R P	REMARKS
				E393B06					
1	6211-310-017-30	GEARCASE ASSY	*	1					
2	6213-319-004-00	CONNECTOR/OILFILTER	*	1					
3	6509-605-019-10	PLUG	*	1					
4	6209-610-002-10	CUP/SEALING/16	*	1					
5	6904-110-822-00	STUD	*	4					
6	6904-110-855-00	STUD	*	2					
7	6904-110-850-00	STUD	*	1					
8	6213-129-005-00	PIN/STRAIGHT	*	1					
9	6209-625-002-00	SEAL,OIL	*	1					
10	V231-360-808-50	FLANGEBOLT	*	1					
11	V231-360-805-50	FLANGEBOLT	*	2					
12	3817-401-001-00	NUT/M08	*	1					
13	V231-360-801-60	FLANGEBOLT	*	3					
14	V231-360-804-50	FLANGEBOLT	*	5					
15	V231-360-807-50	FLANGEBOLT	*	1					
16	1425-621-004-00	HOLDER/JE/9-9	*	2					
17	V231-360-803-00	FLANGEBOLT	*	1					
18	6209-500-003-00	WASHER/08X14X01	*	1					
19	6215-546-003-10	STOPPER/FULLLOAD	*	1					
20	6209-409-001-00	NUT/M8	*	1					
21	V341-120-008-00	NUT,CAP/M 8	*	1					
22	6209-920-002-00	PACKING	*	2					
23	6215-542-004-20	PIN/ARM	*	1					
24	P117-303-003-00	PIN/SNAP	*	2					
25	6215-542-005-10	PIN	*	1					
26	6209-600-004-00	PLUG/SCREW	*	1					
27	6209-500-003-00	WASHER/08X14X01	*	1					
28	6209-740-001-00	PIN,GROOVE	*	1					
29	6211-312-003-20	GASKET/GEARCASE	*	1					
30	6213-160-002-20	VALVE/RELIEF ASSY	*	1					

FIG. 9 TIMING GEAR CASE

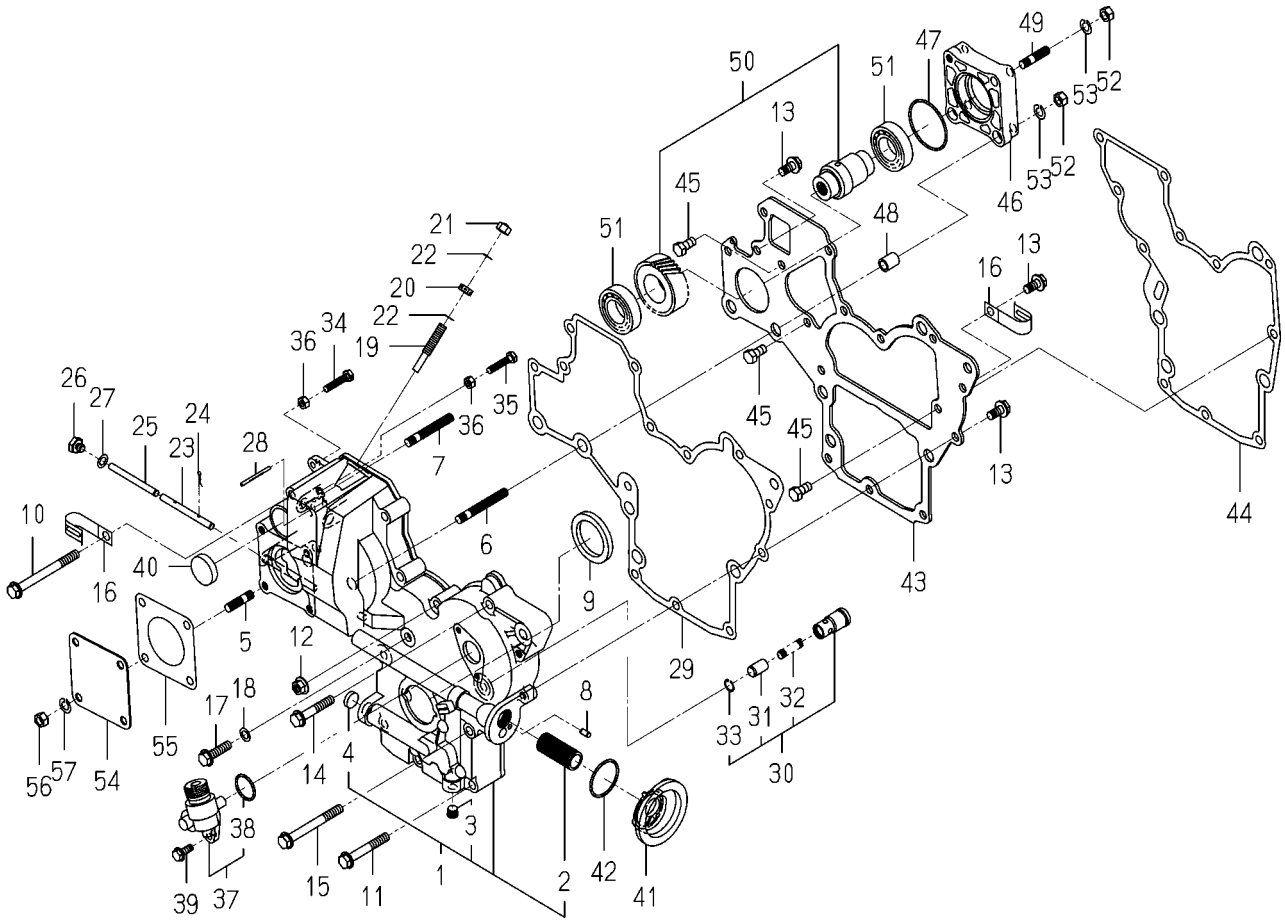

6003-240H-0100,6003-240H-0200

KEY	PART CODE	DESCRIPTION	S P C	TYPE OF MODEL		I T C	C O L	G R P	REMARKS
				E393B06					
31	6213-161-001-20	PISTON/VALVE/RELIEF	*	1					
32	6213-164-001-00	SPRING/RELIEF VALVE	*	1					
33	V705-140-012-00	RING,SNAP/12 C	*	1					
34	6209-050-001-00	BOLT/M6	*	1					
35	6209-050-002-00	BOLT/M6	*	1					
36	6909-110-406-00	NUT	*	2					
37	6219-310-003-20	DRIVE/TACHOMETE ASSY	*	1					
38	V723-102-002-40	RING/O	*	1					
39	V230-360-601-60	FLANGEBOLT	*	2					
40	3625-540-004-00	CAP,BLANK/30	*	1					
41	6213-211-001-10	SPACER,OIL FILTER	*	1					
42	V723-102-003-60	O-RING	*	1					
43	6211-311-011-20	PLATE/FRONT	*	1					
44	6211-312-002-30	GASKET/PLATE	*	1					
45	6902-050-816-00	BOLT	*	3					
46	6211-319-003-00	SPACER	*	1					
47	V723-102-005-00	O-RING 1A S50	*	1					
48	6209-749-001-20	PIN/TUBE	*	2					
49	6904-110-822-00	STUD	*	1					
50	6212-530-005-20	SHAFT/HYDRAULIC ASSY	*	1					
51	V600-110-600-50	BEARING,RB/6005	*	2					
52	6909-110-408-00	NUT/M8	*	4					
53	V401-160-008-00	WASHER,SP/M 8	*	4					
54	6511-321-083-00	COVER	*	1					
55	6211-322-002-00	GASKET/COVER	*	1					
56	6909-110-408-00	NUT/M8	*	4					
57	V401-160-008-00	WASHER,SP/M 8	*	4					

FIG. 15 CRANK SHAFT

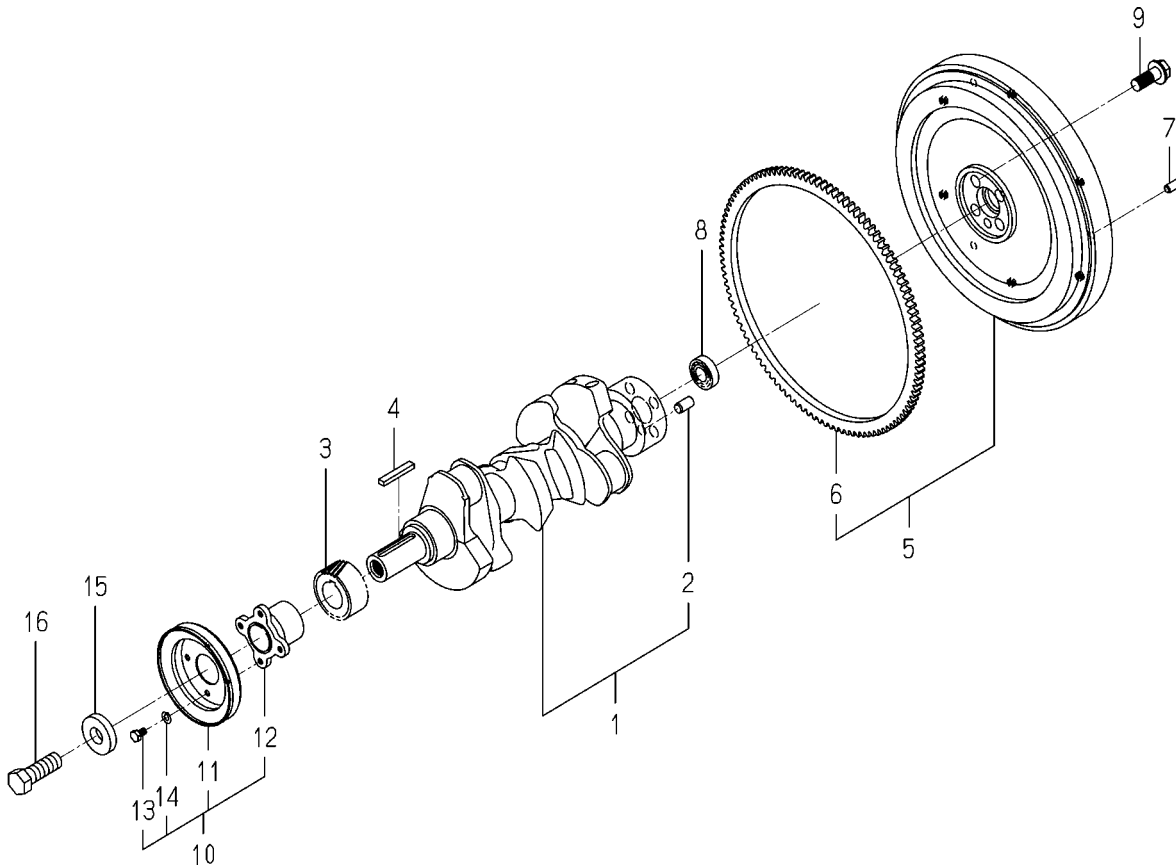

6003-350I-0100

KEY	PART CODE	DESCRIPTION	S P C	TYPE OF MODEL		I T C	C O L	G R P	REMARKS
				E393B06					
1	6212-310-008-40	CRANKSHAFT ASSY	*	1					
2	V523-101-001-80	PIN	*	1					
3	6212-521-008-00	GEAR/CRANK	*	1					
4	6209-730-006-00	KEY/07X05X43	*	1					
5	6212-330-017-30	FLYWHEEL ASSY	*	1					
6	6212-333-003-00	RINGGEAR	*	1					
7	6213-129-006-00	PIN/STRAIGHT	*	3					
8	V600-150-600-20	BEARING,RB/6002SS	*	1					
9	6209-046-015-00	BOLT/FLANGE	*	4					
10	6212-370-011-00	PULLEY ASSY	*	1					
11	6212-371-009-00	PULLEY	*	1					
12	6212-372-002-10	CENTER CRANK PULLEY	*	1					
13	6902-050-610-00	BOLT	*	4					
14	6909-150-506-00	WASHER,SP/M6	*	4					
15	6212-379-001-00	WASHER	*	1					
16	6901-066-645-00	BOLT	*	1					

FIG. 17 WATER PUMP

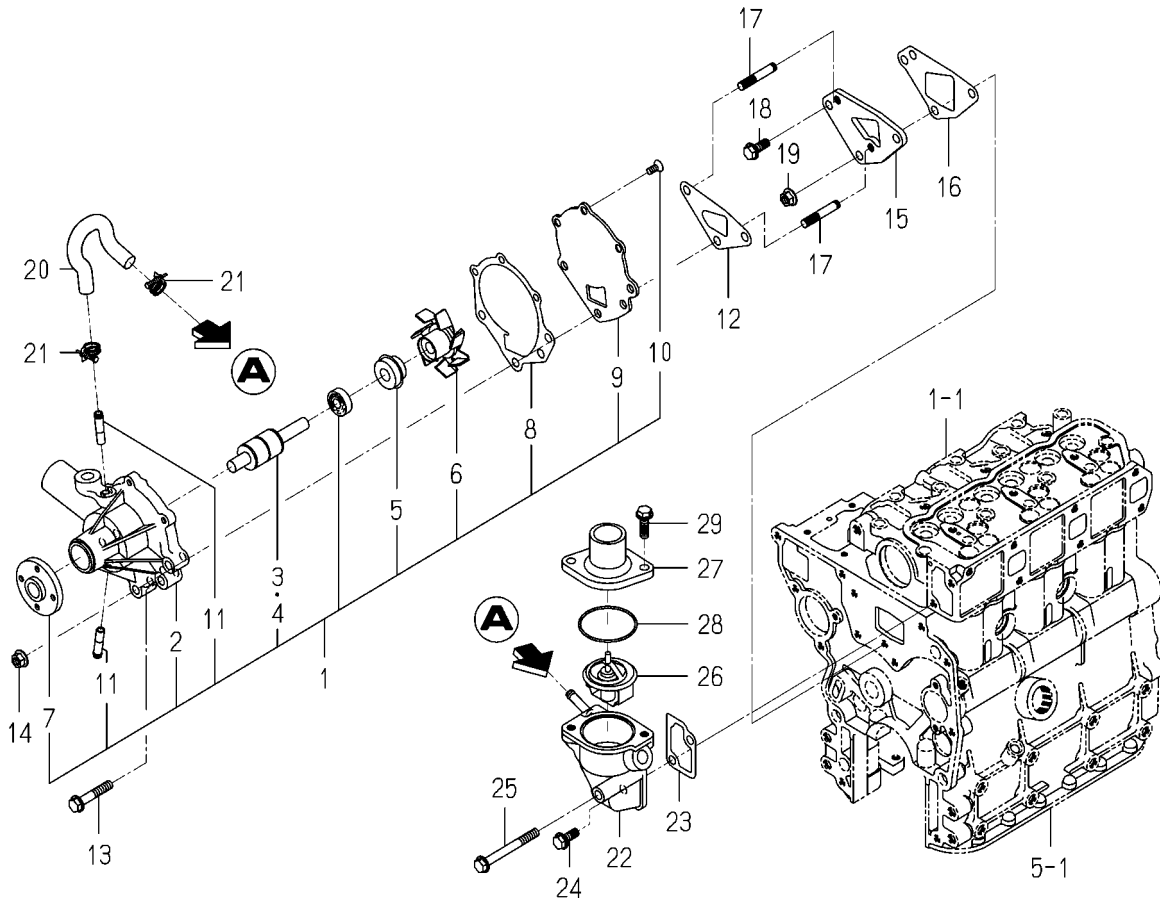

6003-420B-0100

KEY	PART CODE	DESCRIPTION	S P C	TYPE OF MODEL		I T C	C O L	G R P	REMARKS
				E393B06					
1	6213-610-005-40	WATERPUMP ASSY	*	1					
2	6213-611-003-20	BODY/WATERPUMP	*	1					
3	6213-631-002-00	BEARING/WATER PUMP	*	1					
4	6213-631-005-00	BEARING/WATERPUMP	*	1					
5	6213-622-002-10	SEAL SET/WATER PUMP	*	1					
6	6213-621-003-00	ROTOR/WATERPUMP	*	1					
7	6213-642-002-00	SEAL/WATER PUMPPULLE	*	1					
8	6213-613-002-10	GASKET	*	1					
9	6213-612-004-00	PLATE/WATER PUMP	*	1					
10	6213-619-003-00	SCREW/WATER PUMP	*	3					
11	6213-619-002-00	PIPE/WATER PUMP	*	2					
12	6213-614-003-10	GASKET/WATER PUMP	*	1					
13	V231-360-804-50	FLANGEBOLT	*	1					
14	3817-401-001-00	NUT/M08	*	2					
15	6213-619-005-00	SPACER,WATER PUMP	*	1					
16	6213-614-006-10	GASKET/SPACER	*	1					
17	6209-300-002-00	STUD	*	2					
18	V231-360-802-00	FLANGEBOLT	*	1					
19	3817-401-001-00	NUT/M08	*	1					
20	6213-729-013-10	HOSE/RUBBER	*	1					
21	J061-210-015-00	CLAMP/WIRE/10-15	*	2					
22	6213-716-001-50	HOUSING/THERMOSTAT	*	1					
23	6213-743-002-10	GASKET/HOUSING	*	1					
24	V231-360-802-00	FLANGEBOLT	*	1					
25	V231-360-807-50	FLANGEBOLT	*	1					
26	6513-770-022-10	THERMOSTAT	*	1					
27	6213-711-003-20	PIPE,WATER OUTLET	*	1					
28	V723-102-005-50	O-RING	*	1					
29	V231-360-802-50	FLANGEBOLT	*	2					

FIG. 20 INJECTION PUMP

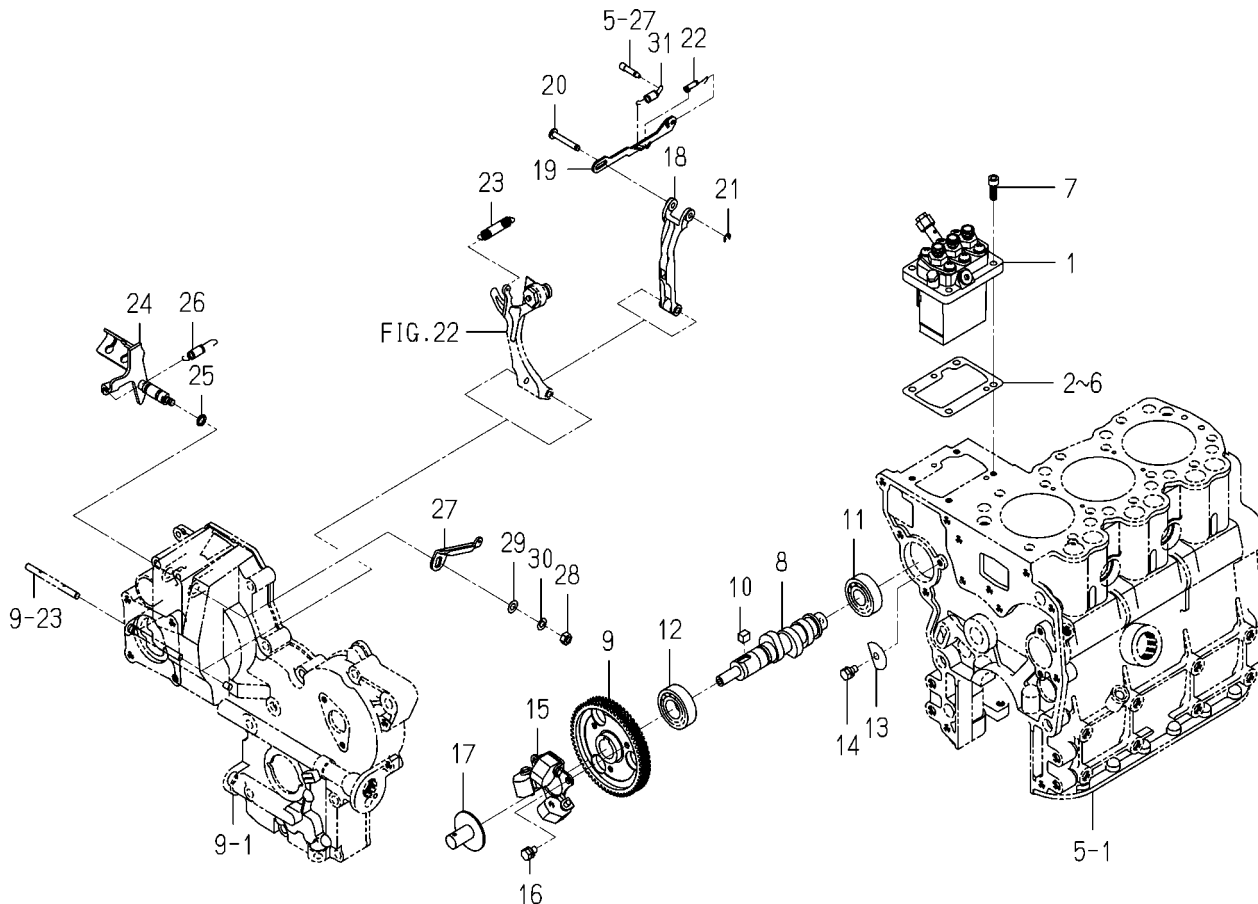

6003-510K-0100

KEY	PART CODE	DESCRIPTION	S P C	TYPE OF MODEL		I T C	C O L	G R P	REMARKS
				E393B06					
1	6215-600-109-30	INJECTIONPUMP ASSY	*	1					FIG 027
2	6219-752-001-00	SHIM/INJECTION P/0.3	*	1					
3	6219-752-002-00	SHIM/INJECTION P/0.1	*	1					
4	6219-752-003-00	SHIM/INJECTION P/0.2	*	1					
5	6219-752-004-00	SHIM/INJECTION P/0.4	*	1					
6	6219-752-005-00	SHIM/INJECTION P/0.5	*	1					
7	6209-056-001-00	BOLT/M6X18	*	4					
8	6215-621-001-40	CAMSHAFT/INJPUMP	*	1					
9	6212-524-002-20	GEAR/INJECTIONPUMP	*	1					
10	6209-730-005-00	KEY/07X05X09	*	1					
11	V600-110-620-30	BEARING,RB/6203	*	1					
12	V600-110-600-40	BEARING,RB/6004	*	1					
13	6212-535-002-00	PLATE,THRUST INJPUMP	*	1					
14	6901-910-612-00	BOLT,SEMS/M6X12	*	1					
15	6215-520-001-00	FLYWEIGHT	*	1					
16	6209-030-043-00	BOLT/M6X10	*	3					
17	6215-526-004-00	THRUSTPIECE	*	1					
18	6215-541-001-10	ARM/FLOATING COMP	*	1					
19	6215-543-001-10	LINK,CONTROL	*	1					
20	6215-542-006-00	PIN,CONTROL	*	1					
21	V710-140-004-00	RING,SNAP/ 4 E	*	1					
22	6215-549-003-00	SPRING,SETTING	*	1					
23	6215-531-021-00	SPRING/GOVERNER	*	1					
24	6215-541-024-30	LEVER/CONTROL COMP	*	1					
25	V720-101-900-80	O-RING/P 8	*	1					
26	6209-580-002-10	SPRING,RETURN	*	1					
27	6215-549-007-10	ARM/CONTROL	*	1					
28	6909-110-406-00	NUT	*	1					
29	V411-260-006-00	WASHER / M6	*	1					
30	V401-160-006-00	WASHER,SP/M 6	*	1					

FIG. 25 REPAIR PARTS (OPTION)

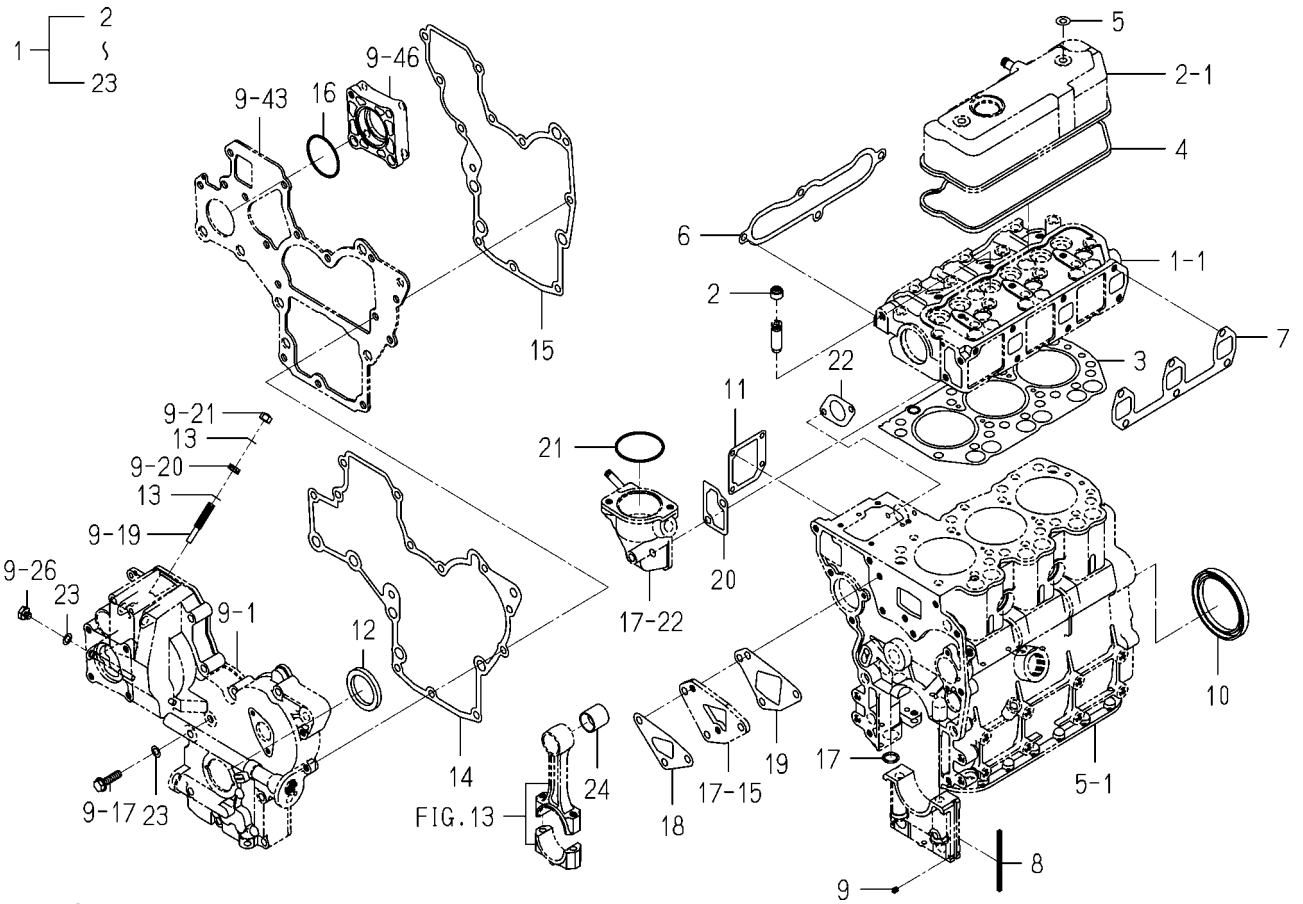

6003-999C-0100

KEY	PART CODE	DESCRIPTION	S P C	TYPE OF MODEL		I T C	C O L	G R P	REMARKS
				E393B06					
1	6287-810-026-10	REPAIR/ENGINESET	T	1					
2	6212-569-002-00	SEAL,OIL	T	6					
3	6211-141-008-30	GASKET/CYLINDERHEAD	T	1					
4	6211-173-003-00	SEAL,CYL.HEAD COVER	T	1					
5	6209-572-003-00	GASKET	T	2					
6	6214-115-001-20	GASKET,INLET MANIFOL	T	1					
7	6214-145-001-30	GASKET,EXH.MANIFOLD	T	1					
8	6211-258-001-00	SEAL,BEARING CAP	T	4					
9	6211-258-002-00	SEAL,BEARING CAP/7	T	2					
10	6209-625-012-00	OILSEAL	T	1					
11	6211-292-001-20	GASKET/COVER	T	1					
12	6209-625-002-00	SEAL,OIL	T	1					
13	6209-920-002-00	PACKING	T	2					
14	6211-312-003-20	GASKET/GEARCASE	T	1					
15	6211-312-004-20	GASKET/PLATE	T	1					
16	V723-102-005-00	O-RING 1A S50	T	1					
17	V720-102-401-50	O-RING/P15	T	1					
18	6213-614-003-10	GASKET/WATER PUMP	T	1					
19	6213-614-006-10	GASKET/SPACER	T	1					
20	6213-743-002-10	GASKET/HOUSING	T	1					
21	V723-102-005-50	O-RING	T	1					
22	6209-630-002-10	GASKET	T	1					
23	6209-500-003-00	WASHER/08X14X01	T	2					

**FIG. 27 COMPONENT PARTS
FOR 6215-600-109-30 ON Fig.20**

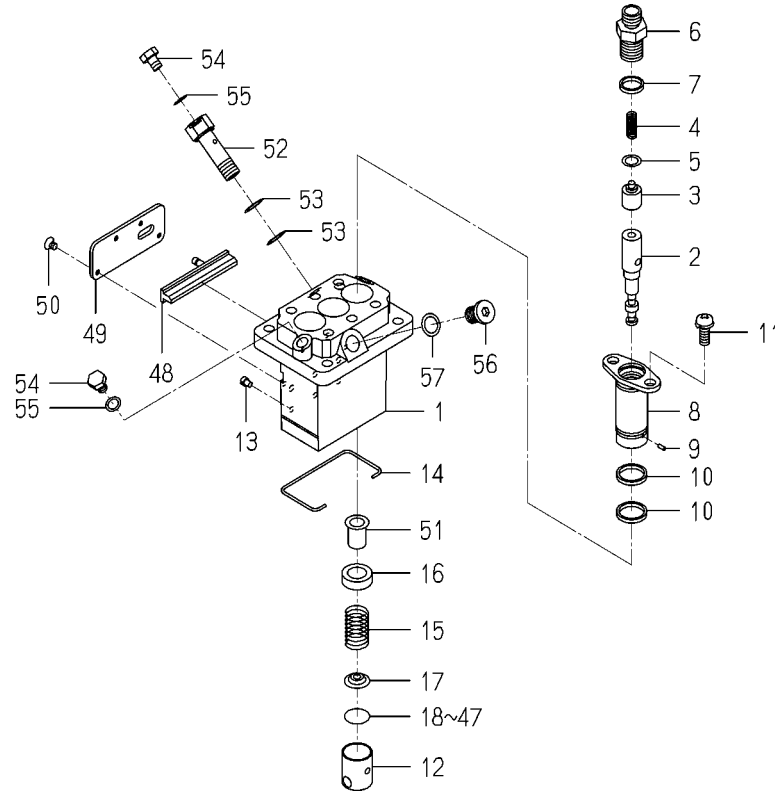

6215-600-109-3G

KEY	PART CODE	DESCRIPTION	S P C	TYPE OF MODEL		I T C	C O L	G R P	REMARKS
				E393B06					
1	6215-611-002-00	HOUSING,PUMP	*	1					
2	6215-631-017-00	PLUNGER ASSY	*	3					
3	6215-641-007-00	DELIVERYVALVE	*	3					
4	6215-643-002-00	SPRING DELIVERY VALV	*	3					
5	6215-649-003-00	GASKET	*	3					
6	6215-644-002-00	HOLDER DELIVERY VALV	*	3					
7	6215-649-004-10	ORING	*	3					
8	6215-635-002-00	SLEEVE,FRANGE	*	3					
9	6215-649-005-00	PIN	*	3					
10	6215-649-006-10	ORING	*	6					
11	6215-649-007-00	SCREW	*	6					
12	6215-622-002-00	TAPPET	*	3					
13	6215-629-017-00	PIN	*	3					
14	6215-629-018-00	RING,SNAP	*	1					
15	6215-634-002-00	SPRING,PLUNGER	*	3					
16	6215-639-006-00	SEAT,SPRING	*	3					
17	6215-639-007-00	SEAT,SPRING	*	3					
18	6215-629-020-00	PLATE/T=1.80	*	1					
19	6215-629-021-00	PLATE/T=1.85	*	1					
20	6215-629-022-00	PLATE/T=1.90	*	1					
21	6215-629-023-00	PLATE/T=1.95	*	1					
22	6215-629-024-00	PLATE/T=2.00	*	1					
23	6215-629-025-00	PLATE/T=2.05	*	1					
24	6215-629-026-00	PLATE/T=2.10	*	1					
25	6215-629-027-00	PLATE/T=2.15	*	3					
26	6215-629-028-00	PLATE/T=2.20	*	1					
27	6215-629-029-00	PLATE/T=2.25	*	1					
28	6215-629-030-00	PLATE/T=2.30	*	1					
29	6215-629-031-00	PLATE/T=2.35	*	1					
30	6215-629-032-00	PLATE/T=2.40	*	1					

**FIG. 28 COMPONENT PARTS
FOR 6281-100-014-00 ON Fig.23**

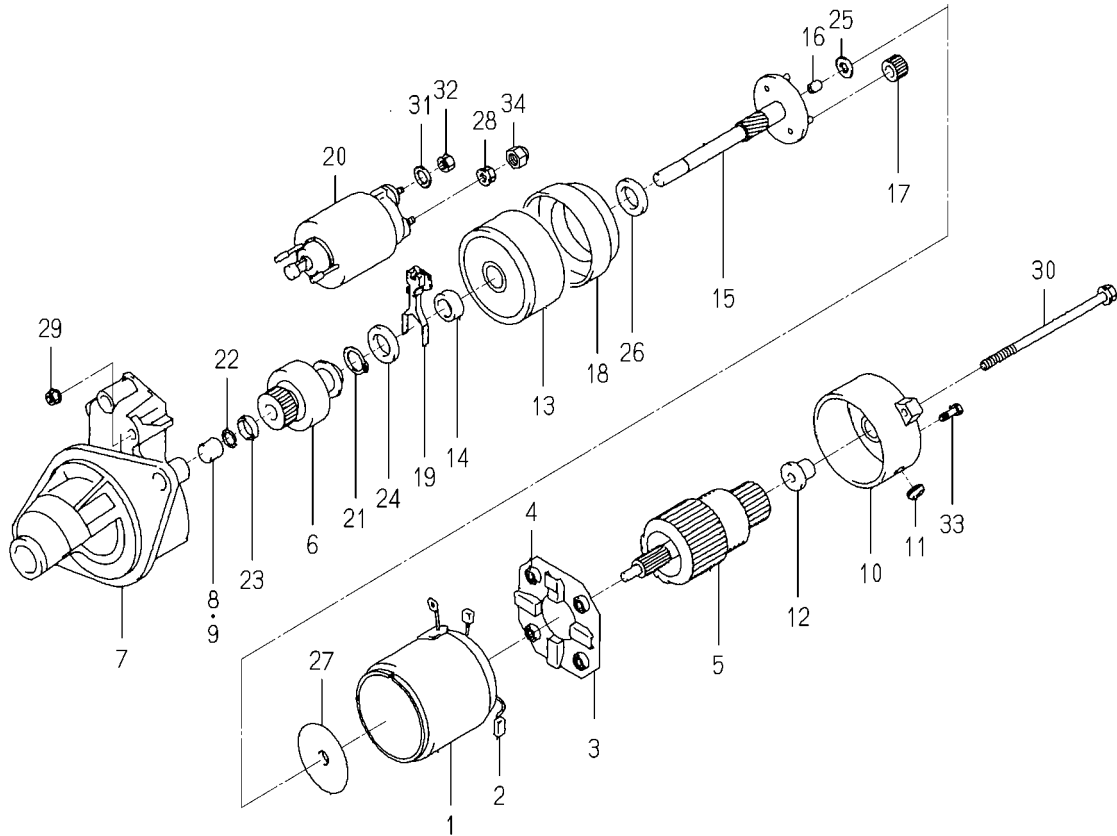

6281-100-014-0A

KEY	PART CODE	DESCRIPTION	S P C	TYPE OF MODEL		I T C	C O L	G R P	REMARKS
				E393B06					
1	6281-111-009-00	YOKE/STARTER ASSY	*	1					
2	6281-119-009-00	BRUSH/STARTER	*	2					
3	6281-118-007-00	HOLDER/STARTER ASSY	*	1					
4	6281-117-003-00	SPRING/STARTERBRUSH	*	4					
5	6281-121-010-00	ARMATURE/STARTE ASSY	*	1					
6	6281-124-011-00	CLUTCH/STARTER ASSY	*	1					
7	6281-129-064-00	HOUSING/STARTER ASSY	*	1					
8	6281-129-080-00	BEARING/NEEDLE	*	1					
9	6281-129-058-00	BEARING/NEEDLE	*	1					
10	6281-115-017-00	FRAME/COMMUTATOR END	*	1					
11	6281-115-018-00	COVER	*	1					
12	6281-129-065-00	BEARING/OILLESS	*	1					
13	6281-129-066-00	BEARING/WITH SHOCKAB	*	1					
14	6281-129-067-00	BEARING/OILLESS	*	1					
15	6281-129-068-00	SHAFT/STARTER PLANET	*	1					
16	6281-129-069-00	BEARING/OILLESS	*	1					
17	6281-129-070-00	GEAR/STARTER PLANETA	*	3					
18	6281-129-071-00	GEAR/STARTERINTERNAL	*	1					
19	6281-127-003-00	LEVER/PINIONDRIVE	*	1					
20	6281-151-014-00	SWITCH/MAGNETIC ASSY	*	1					
21	6281-129-072-00	RING/SNAP	*	1					
22	6281-129-073-00	RING/SNAP	*	1					
23	6281-129-074-00	NUT/PINIONSTOP	*	1					
24	6281-129-075-00	WASHER/SK	*	1					
25	6281-129-076-00	WASHER/SK	*	1					
26	6281-129-077-00	WASHER/SK	*	1					
27	6281-129-078-00	PLATE	*	1					
28	6281-129-030-00	NUT	*	1					
29	6281-129-029-00	NUT	*	2					
30	6281-129-043-00	BOLT/THROUGH	*	2					

CHASSIS

CHASSIS

FIG. 1 RADIATOR SYSTEM

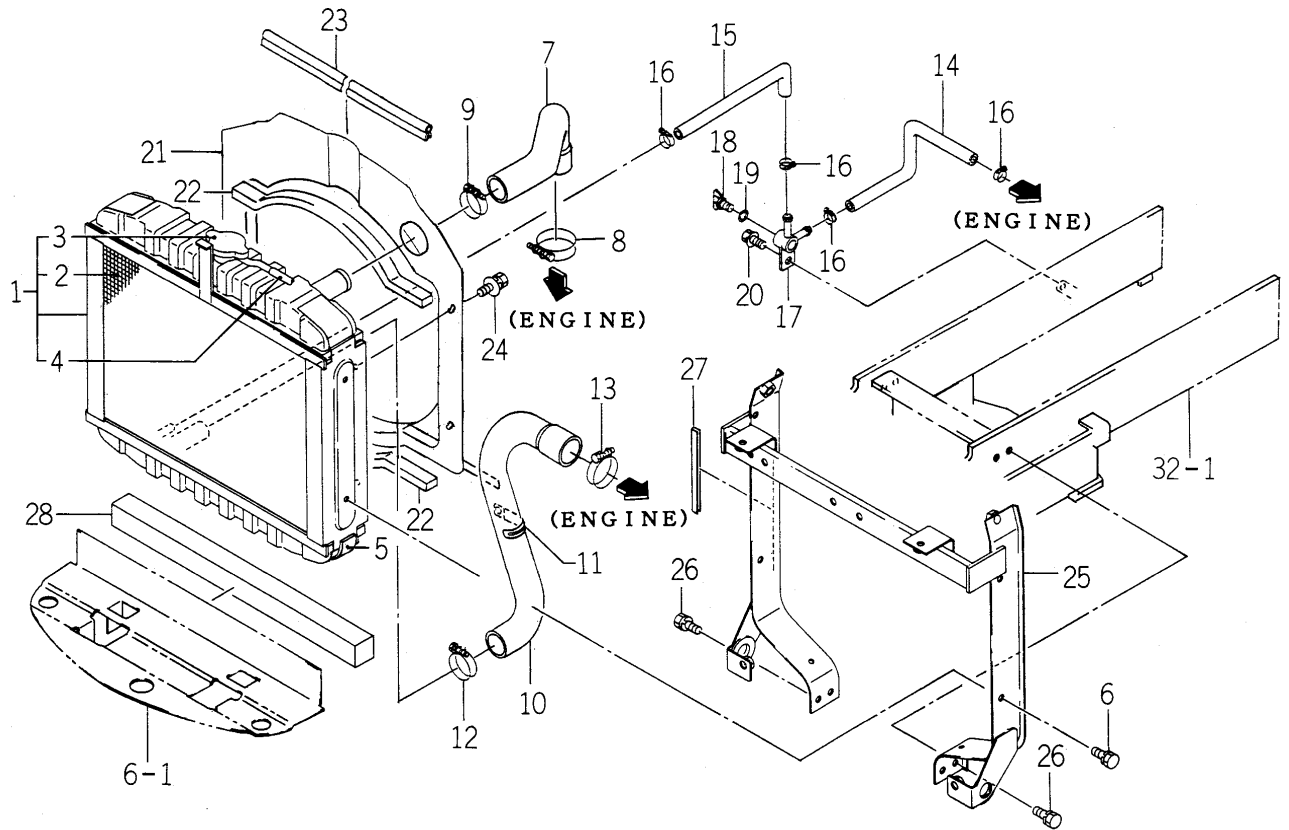

1738-102-0100

KEY	PART CODE	DESCRIPTION	S P C	TYPE OF MODEL		I T C	C O L	G R P	REMARKS
				TM3160					
1	1726-102-210-00	RADIATOR ASSY	*	1					
2	1726-102-211-00	NET/WIRE COMP	*	1					
3	1614-102-213-00	CAP	*	1					
4	1614-102-214-00	HOSE	*	1					
5	1612-102-005-00	INSULATOR	*	1					
6	V211-260-801-60	BOLT,SEMS (S) M8X16	*	4					
7	1675-102-004-00	HOSE/RADIATOR/INLET	*	1					
8	J061-236-044-00	CLAMP/WIRE/36-44	*	1					
9	J061-230-038-00	CLAMP/WIRE/30-38	*	1					
10	1675-102-006-00	HOSE/RADIATOR/OUTLET	*	1					
11	1425-621-004-00	HOLDER/JE/9-9	*	1					
12	J061-224-032-00	CLAMP/WIRE/24-32	*	1					
13	J061-236-044-00	CLAMP/WIRE/36-44	*	1					
14	1617-102-005-00	HOSE/170	*	1					
15	1560-104-006-60	HOSE/290	*	1					
16	J061-210-015-00	CLAMP/WIRE/10-15	*	4					
17	1560-104-010-40	CONNECTOR	*	1					
18	1424-101-203-00	PLUG	*	1					
19	1424-101-204-00	PACKING	*	1					
20	V211-360-802-00	BOLT/SP	*	1					
21	1683-102-220-00	SHROUD COMP	*	1					
22	1675-102-002-00	INSULATOR	*	2					
23	1716-102-003-00	INSULATOR/550	*	1					
24	V210-360-601-20	BOLT,SEMS	*	4					
25	1726-102-200-10	BRACKET/RADIATO COMP	*	1					
26	V211-260-801-60	BOLT,SEMS (S) M8X16	*	4					
27	1705-102-014-00	TRIM/130	*	1					
28	1726-102-001-00	INSULATOR	*	1					

FIG. 4 FILTER SYSTEM

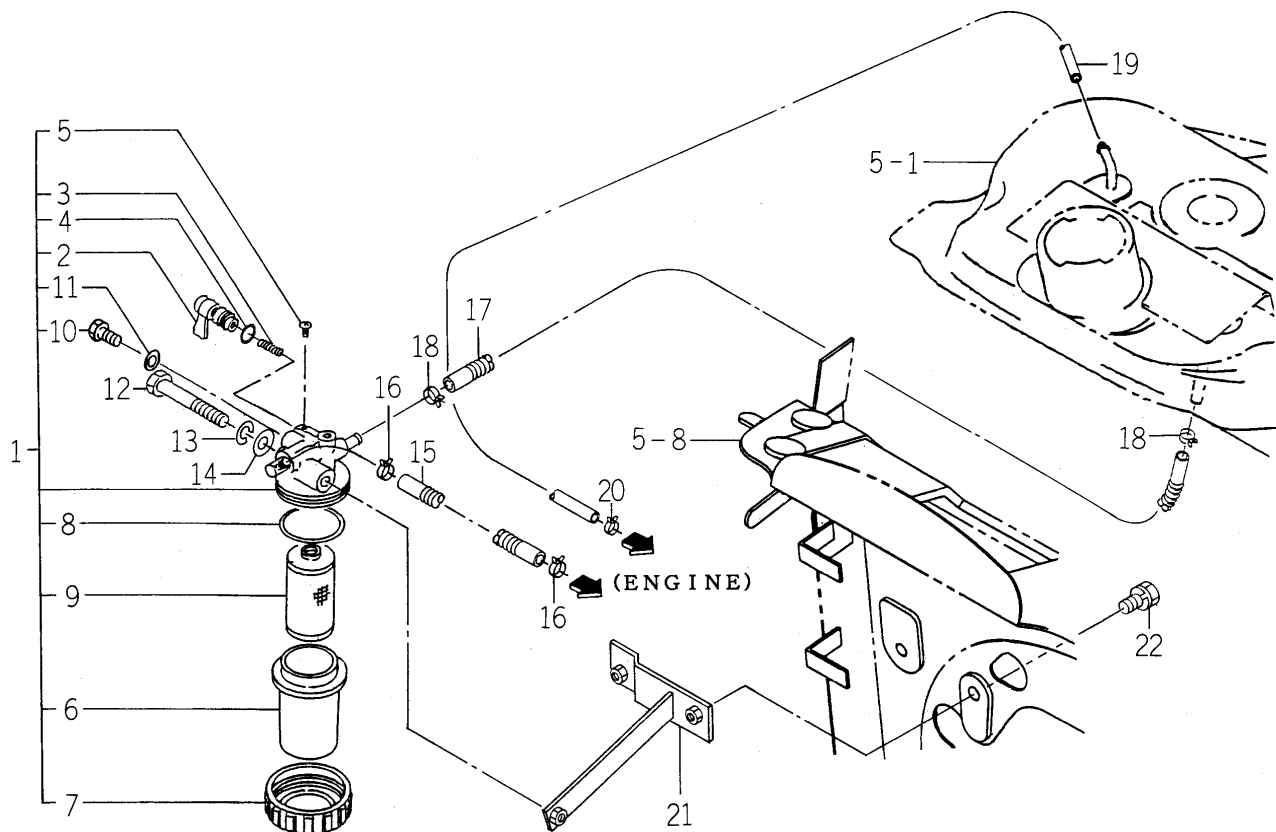

1738-105-0100

KEY	PART CODE	DESCRIPTION	S P C	TYPE OF MODEL		I T C	C O L	G R P	REMARKS
				TM3160					
1	1509-105-210-00	FILTER/FUEL	*	1					
2	1444-102-202-00	LEVER	*	1					
3	1415-102-007-00	SPRING, VALVE	*	1					
4	V720-102-401-00	O-RING/P10A	*	1					
5	1415-102-008-00	VIS	*	1					
6	1440-103-201-00	CAP	*	1					
7	1444-102-204-00	NUT, RING	*	1					
8	V720-103-504-40	O-RING/P44	*	1					
9	1672-105-211-00	ELEMENT	*	1					
10	1572-102-003-00	BOLT/M06X08/APSET	*	2					
11	1415-102-013-00	PACKING	*	2					
12	V201-260-806-50	BOLT/M 8X65	*	1					
13	V401-160-008-00	WASHER, SP/M 8	*	1					
14	V411-260-008-00	WASHER, PL/M 8	*	1					
15	1716-105-001-00	HOSE/08X13X300	*	1					
16	J062-119-126-00	CLIP/HOSE/11.9-12.6	*	2					
17	1726-105-001-10	HOSE/08X13X110	*	1					
18	J062-119-126-00	CLIP/HOSE/11.9-12.6	*	2					
19	1612-105-002-00	HOSE/650	*	1					
20	J062-081-087-00	CLIP/HOSE/8.1-8.7	*	1					
21	1738-105-210-00	BRACKET/FILTER COMP	*	1					
22	V211-260-801-60	BOLT, SEMS (S) M8X16	*	2					

FIG. 8 MAIN CLUTCH, INPUT SHAFT SYSTEM

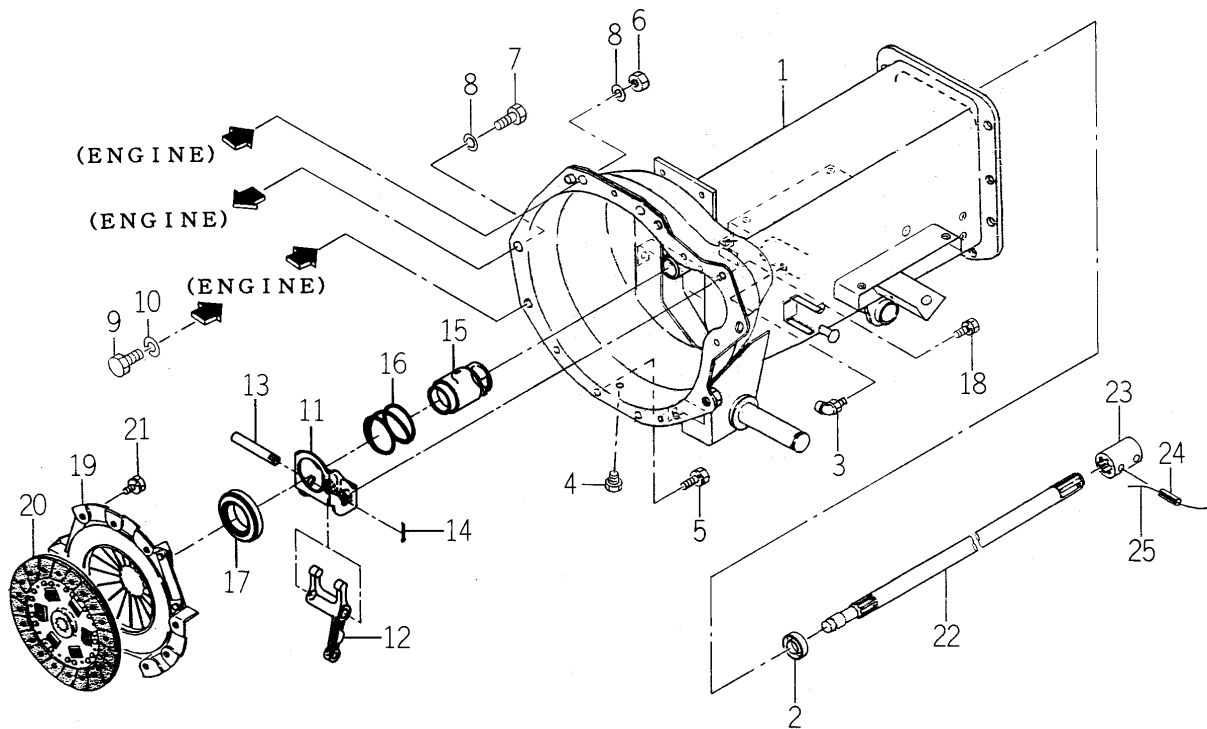

1738-120 -0100,1738-125 -0100

KEY	PART CODE	DESCRIPTION	S P C	TYPE OF MODEL		I T C	C O L	G R P	REMARKS
				TM3160					
1	1738-120-210-20	HOUSING/CLUTCH COMP	*	1					
2	V744-120-350-70	SEAL,OIL/TC20357	*	1					
3	V763-150-000-00	NIPPLE,GREASE/PT1/8	*	1					
4	V782-160-000-2T	PLUG/SCREW/SEAL	*	1					
5	V211-260-801-60	BOLT,SEMS (S) M8X16	*	4					
6	V334-460-010-00	NUT/M10 7T P=1.25	*	2					
7	V203-361-002-00	BOLT/M10X1.25X20	*	2					
8	V401-160-010-00	WASHER,SP/M10	*	4					
9	V201-361-202-50	BOLT/M12X25	*	2					
10	V401-160-012-00	WASHER,SP/M12	*	2					
11	1434-122-230-10	BRACKET COMP	*	1					
12	1435-122-002-00	FORK/RELEASE	*	1					
13	1672-120-006-00	PIN/12X75	*	1					
14	V500-163-002-00	PIN,SPLIT/3 X20	*	1					
15	1672-120-007-00	SLEEVE	*	1					
16	1434-120-005-00	SPRING/HC50	*	1					
17	1491-120-001-00	BEARING,CLUTCH RS	*	1					
18	V211-260-801-60	BOLT,SEMS (S) M8X16	*	2					
19	1716-120-200-00	COVER/CLUTCH/18 COMP	*	1					
20	1717-120-230-10	DISK/CLUTCH/184 COMP	*	1					
21	V211-260-802-00	BOLT/S	*	6					
22	1682-120-001-00	SHAFT/INPUT	*	1					
23	1435-120-002-30	COUPLING/16X27X62	*	1					
24	V580-140-602-80	PIN,SPRING/6 X28 W	*	2					
25		WIRE	*	1					

FIG. 10 CASE (TRANSMISSION) SYSTEM

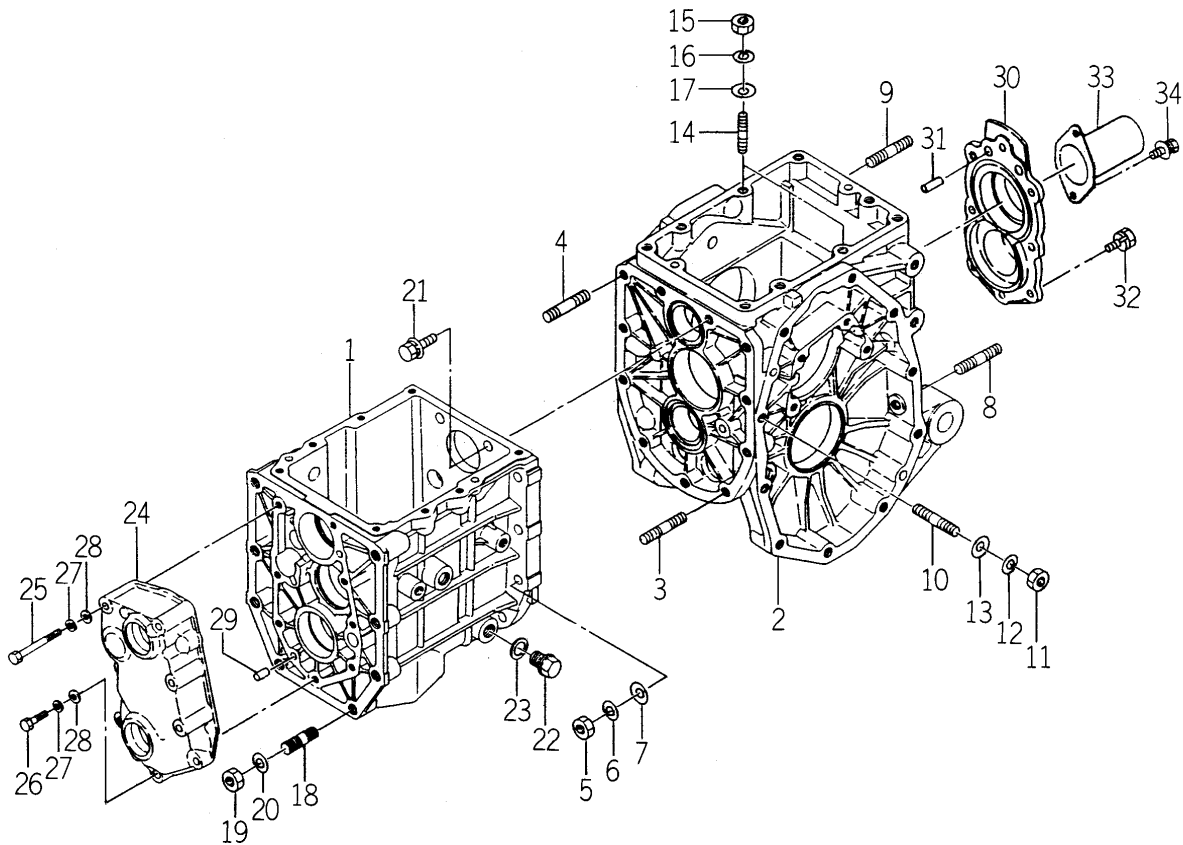

1738-201 -0100

KEY	PART CODE	DESCRIPTION	S P C	TYPE OF MODEL		I T C	C O L	G R P	REMARKS
				TM3160					
1	1682-201-001-10	CASE/TRANSMISSION/F	*	1					
2	1688-201-055-10	CASE/TRANSMISSION/RE	*	1					
3	V252-341-003-00	BOLT/STUD	*	2					
4	V252-341-003-50	BOLT/M10X35	*	7					
5	V304-260-010-00	NUT	*	9					
6	V401-160-010-00	WASHER,SP/M10	*	9					
7	V411-260-010-00	WASHER/M10	*	9					
8	V251-261-202-5D	BOLT/STUD/SEAL	*	2					
9	V252-341-202-50	BOLT/STUD	*	4					
10	V252-261-005-50	BOLT/M10X55	*	4					
11	V304-260-010-00	NUT	*	4					
12	V401-160-010-00	WASHER,SP/M10	*	4					
13	V411-260-010-00	WASHER/M10	*	4					
14	V252-341-003-00	BOLT/STUD	*	2					
15	V304-260-010-00	NUT	*	2					
16	V401-160-010-00	WASHER,SP/M10	*	2					
17	V411-260-010-00	WASHER/M10	*	2					
18	V252-341-203-00	BOLT/M12X30	*	8					
19	V304-460-012-00	NUT/M12	*	8					
20	V401-160-012-00	WASHER,SP/M12	*	8					
21	V211-361-003-50	BOLT/M10X35	*	2					
22	1427-201-007-00	PLUG,DRAIN	*	1					
23	1427-201-008-00	WASHER,SEAL/16	*	1					
24	1427-201-005-00	METAL/INPUT	*	1					
25	V201-260-806-00	BOLT/M 8X60	*	4					
26	V201-260-803-50	BOLT/M 8X35	*	4					
27	V401-160-008-00	WASHER,SP/M 8	*	8					
28	V411-260-008-00	WASHER,PL/M 8	*	8					
29	V522-100-801-80	PIN	*	2					
30	1688-201-056-00	METAL/PTO	*	1					

FIG. 15 LEVER (MAIN) SYSTEM

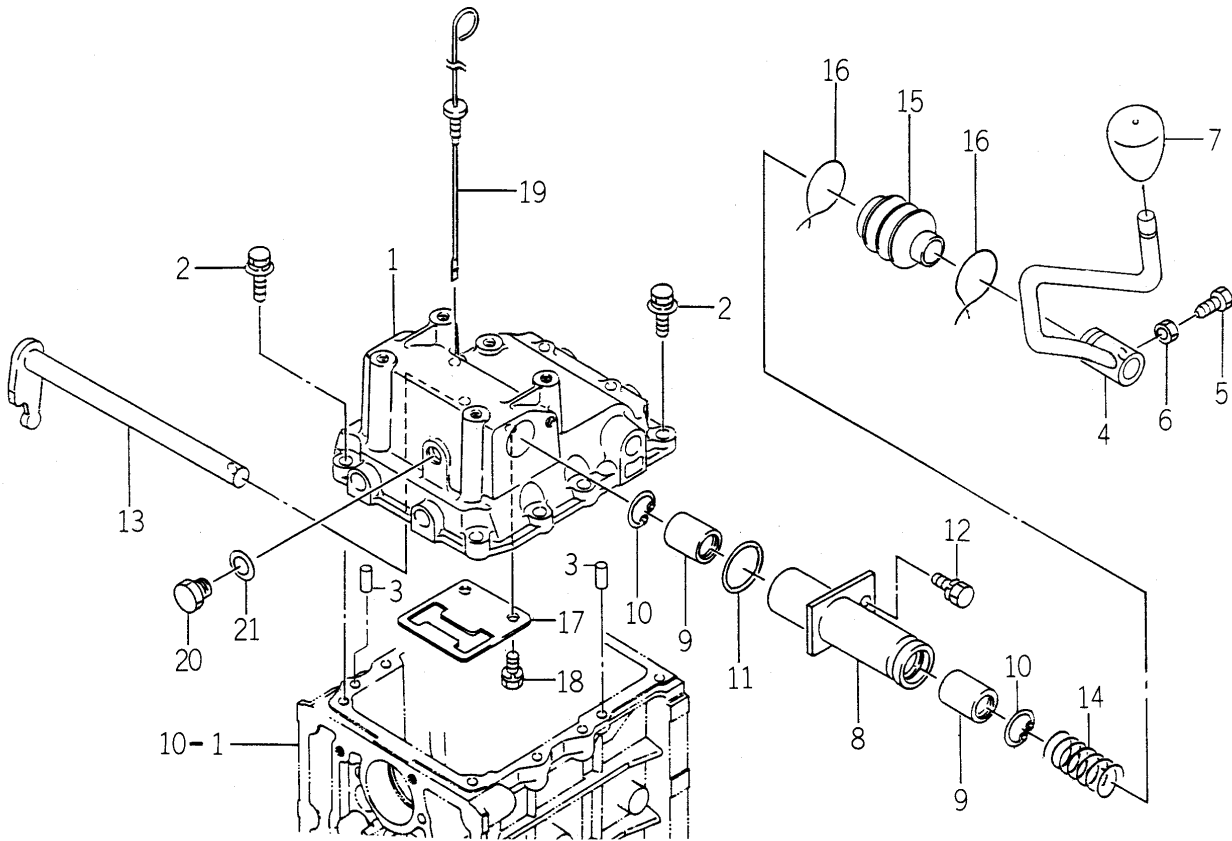

1738-207 -0100,1672-207A-0100

KEY	PART CODE	DESCRIPTION	S P C	TYPE OF MODEL		I T C	C O L	G R P	REMARKS
				TM3160					
1	1672-207-001-10	METAL/SHIFT	*	1					
2	V211-360-803-00	BOLT/SP	*	8					
3	V522-100-801-80	PIN	*	2					
4	1738-207-200-10	LEVER/MAIN COMP	*	1					
5	1600-502-003-00	BOLT,SM/M08X25	*	1					
6	V304-260-008-00	NUT	*	1					
7	1636-271-013-00	GRIP/12X50	*	1					
8	1672-207-240-00	TUBE/SHIFT/MAIN COMP	*	1					
9	1544-215-015-00	BEARING	*	2					
10	V705-140-028-00	RING,SNAP/28 C	*	2					
11	V723-102-003-00	O-RING	*	1					
12	V211-260-802-00	BOLT/S	*	1					
13	1672-207-230-00	ARM/SHIFT/MAIN COMP	*	1					
14	1614-215-006-00	SPRING/HC060	*	1					
15	1544-215-016-00	BOOT,CHANGE	*	1					
16		WIRE	*	2					
17	1672-207-002-10	PLATE/GUIDE	*	1					
18	V211-560-802-00	BOLT/M8X20	*	2					
19	1614-501-006-00	GAUGE/OIL	*	1					
20	1564-667-002-00	BLOT/M14X10	*	1					
21	1488-541-021-00	SHIM/T=0.7	*	1					

FIG. 18 CHANGE (MAIN/SUB) SYSTEM

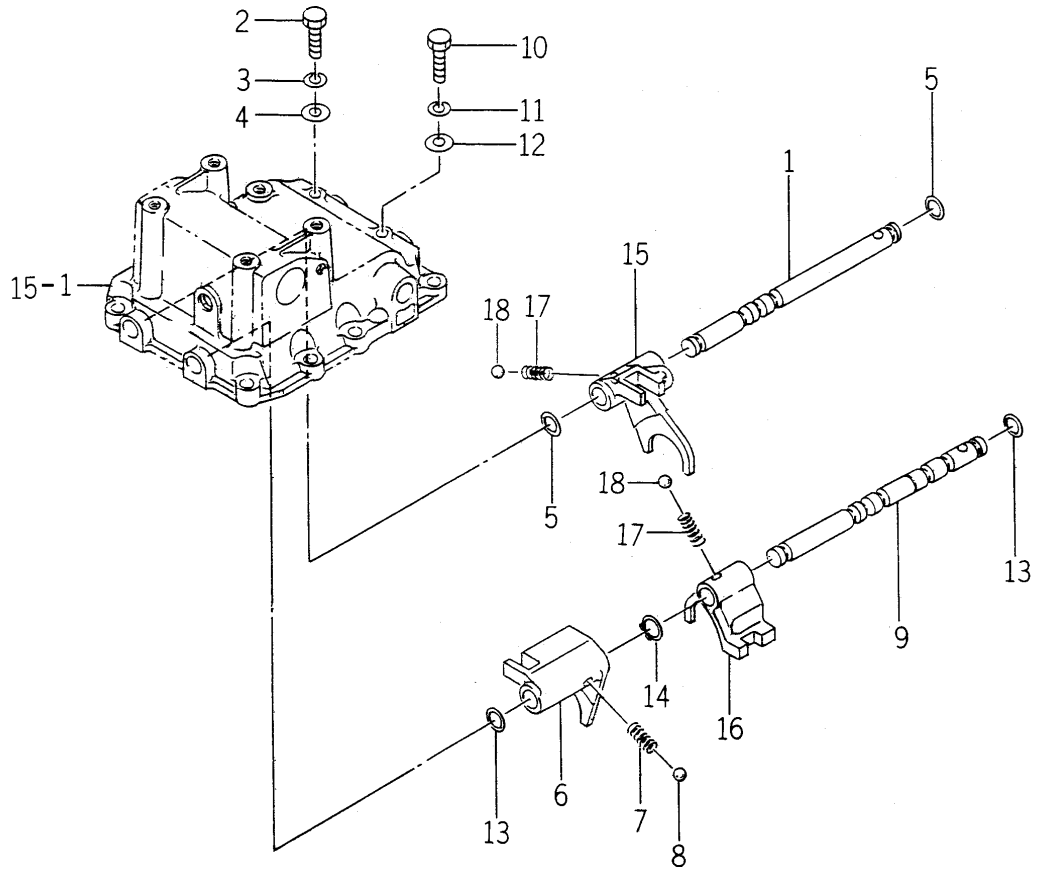

1682-210-0100

KEY	PART CODE	DESCRIPTION	S P C	TYPE OF MODEL		I T C	C O L	G R P	REMARKS
				TM3160					
1	1672-210-001-00	STAY/SHIFT/1ST	*	1					
2	1427-210-003-00	BOLT/M8X25	*	1					
3	V401-160-008-00	WASHER,SP/M 8	*	1					
4	V411-260-008-00	WASHER,PL/M 8	*	1					
5	V720-102-401-00	O-RING/P10A	*	2					
6	1672-210-002-00	FORK/SHIFT/1ST	*	1					
7	1650-259-010-00	SPRING/HC023	*	1					
8	V682-200-001-00	BALL	*	1					
9	1672-210-003-10	STAY/SHIFT/2ND	*	1					
10	1427-210-003-00	BOLT/M8X25	*	1					
11	V401-160-008-00	WASHER,SP/M 8	*	1					
12	V411-260-008-00	WASHER,PL/M 8	*	1					
13	V720-102-401-00	O-RING/P10A	*	2					
14	V704-140-014-00	RING,SNAP/14 C	*	1					
15	1672-210-004-00	FORK/SHIFT/2ND	*	1					
16	1672-210-005-00	FORK/SHIFT/SUB	*	1					
17	1650-259-010-00	SPRING/HC023	*	2					
18	V682-200-001-00	BALL	*	2					

FIG. 23 MID PTO SYSTEM(1/2)

30— PLEASE SEE NEXT PAGE

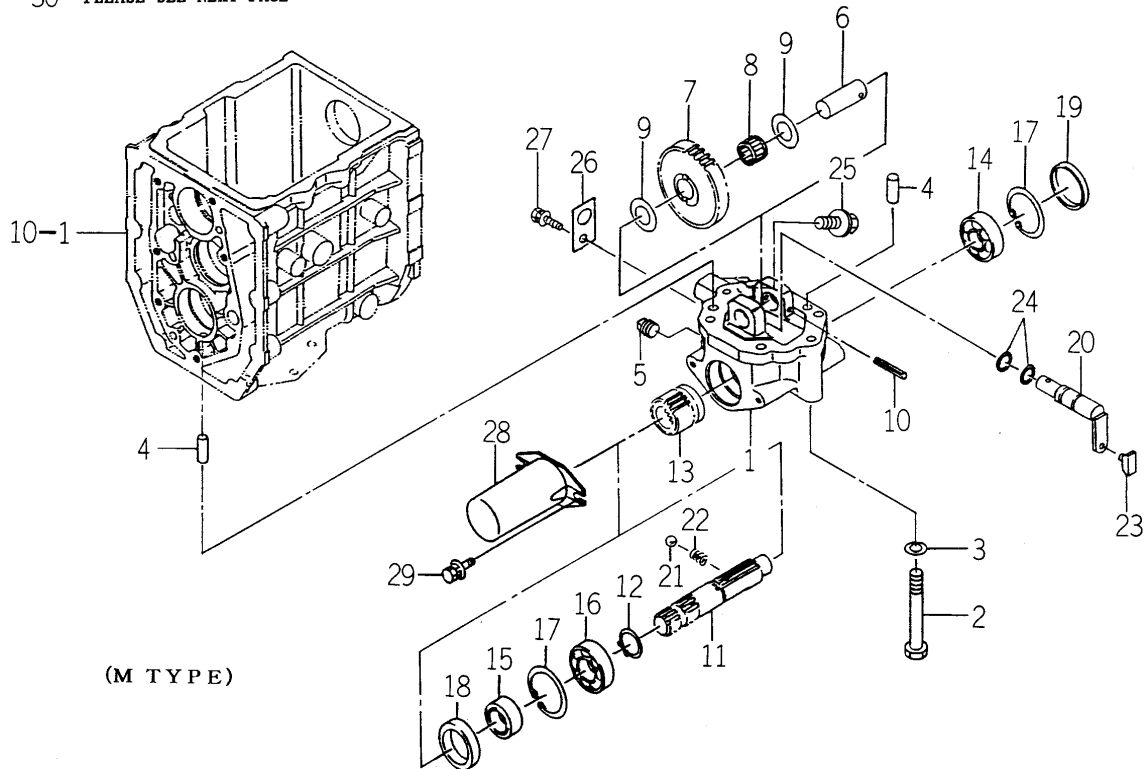

1738-255-0100,1682-255A-0100

KEY	PART CODE	DESCRIPTION	S P C	TYPE OF MODEL		I T C	C O L	G R P	REMARKS
				TM3160					
1	1682-255-201-10	CASE/PTO/MID	*	1					
2	V201-361-009-00	BOLT/M10X90	*	6					
3	V401-160-010-00	WASHER,SP/M10	*	6					
4	V523-101-002-40	PIN	*	2					
5	V781-160-000-6B	PLUG/SCREW/SEAL	*	1					
6	1682-255-203-00	PIN/20X51	*	1					
7	1682-255-202-00	GEAR/SPUR/34	*	1					
8	1682-255-002-20	BEARING/NEEDLE	*	1					
9	1480-212-003-00	COLLAR/21X36X1	*	2					
10	V580-140-604-00	PIN,SPRING/6 X40 W	*	1					
11	1682-255-204-00	SHAFT/PTO/MID	*	1					
12	V704-140-025-00	RING,SNAP/25 C	*	1					
13	1682-255-205-10	GEAR/SPUR/15	*	1					
14	V600-110-630-40	BEARING,RB/6304	*	1					
15	1427-212-003-20	SLEEVE	*	1					
16	V600-110-620-50	BEARING,RB/6205	*	1					
17	V705-140-052-00	RING,SNAP/52 C	*	2					
18	V744-135-520-80	SEAL,OIL/TC35528	*	1					
19	3625-701-003-00	CAP,BLANK/52	*	1					
20	1682-255-210-40	ARM/SHIFT/MID COMP	*	1					
21	V682-200-001-00	BALL	*	1					
22	1302-225-003-00	SPRING,SHIFTER	*	1					
23	2703-101-020-00	COLLAR,SHIFTER	*	1					
24	V720-102-401-40	O-RING/P14	*	2					
25	V233-361-201-60	FLANGEBOLT	*	1					
26	1620-255-208-00	PLATE/I/30X50	*	1					
27	V211-360-801-60	BOLT,SEMS (SP)	*	1					
28	1444-314-009-10	CAP,PTO SHAFT	*	1					
29	V210-360-602-00	BOLT/SP	*	2					
30	1738-255-310-10	LEVER/PTO/MID COMP	*	1					

FIG. 24 DIFF CASE SYSTEM

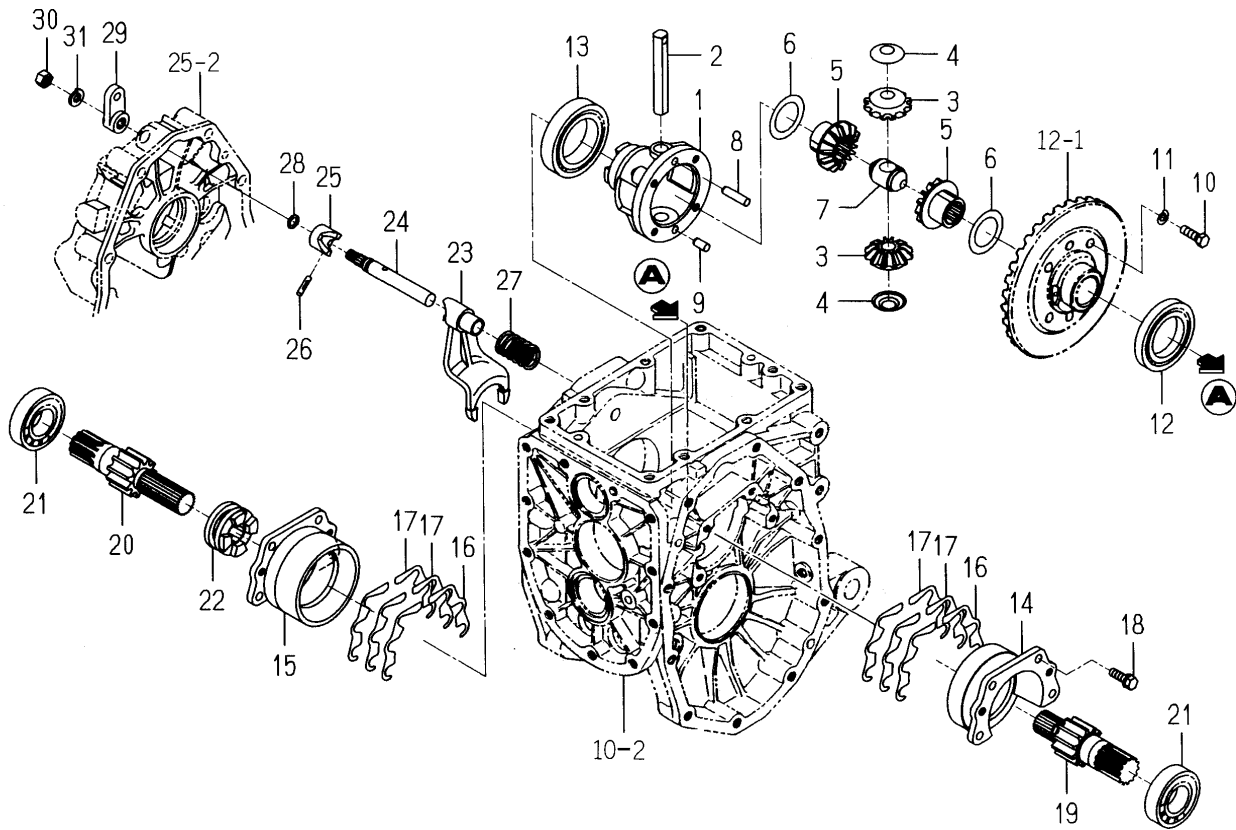

1717-304 -0100

KEY	PART CODE	DESCRIPTION	S P C	TYPE OF MODEL		I T C	C O L	G R P	REMARKS
				TM3160					
1	1427-301-002-20	CASE,DIFF	*	1					
2	1444-411-006-00	SHAFT,DIFF. PINION	*	1					
3	1672-301-003-00	PINION/BEVEL/12	*	2					
4	1427-301-005-00	COLLAR,PINION THRUST	*	2					
5	1672-301-004-00	GEAR/BEVEL/14	*	2					
6	1427-301-007-00	COLLAR,THRUST	*	2					
7	1427-301-009-00	HOLDER,PINION SHAFT	*	1					
8	1672-301-002-00	PIN	*	1					
9	V523-100-801-60	PIN	*	1					
10	1544-304-006-10	BOLT/M8X25	*	4					
11	V401-160-008-00	WASHER,SP/M 8	*	4					
12	V600-110-600-90	BEARING,RB/6009	*	1					
13	V600-110-601-00	BEARING,RB/6010	*	1					
14	1427-201-012-00	METAL,DIFF-CASE LH	*	1					
15	1427-201-013-00	METAL,DIFF-CASE RH	*	1					
16	1427-201-014-10	SHIM,DIFF-CASE A	*	8					
17	1427-201-015-10	SHIM,DIFF-CASE B	*	4					
18	V211-560-802-50	BOLT,SEMS/M8X25 7T	*	8					
19	1717-304-001-00	GEAR/SPUR/11/LH	*	1					
20	1717-304-002-00	GEAR/SPUR/11/RH	*	1					
21	V600-110-620-60	BEARING,RB/6206	*	2					
22	1427-301-013-20	CLUTCH/DIFFLOCK	*	1					
23	1427-301-014-10	FORK/SHIFT/DIFFLOCK	*	1					
24	1427-301-015-10	STAY,SHIFTER	*	1					
25	1427-301-016-00	CAM,DIFF-LOCK	*	1					
26	V530-240-502-40	PIN/SLITTED	*	1					
27	1427-301-018-00	SPRING,PRESS/40	*	1					
28	V720-102-401-00	O-RING/P10A	*	1					
29	1427-301-019-00	ARM/DIFFLOCK	*	1					
30	V304-260-010-00	NUT	*	1					

FIG. 29 PEDAL (BRAKE) SYSTEM(1/2)

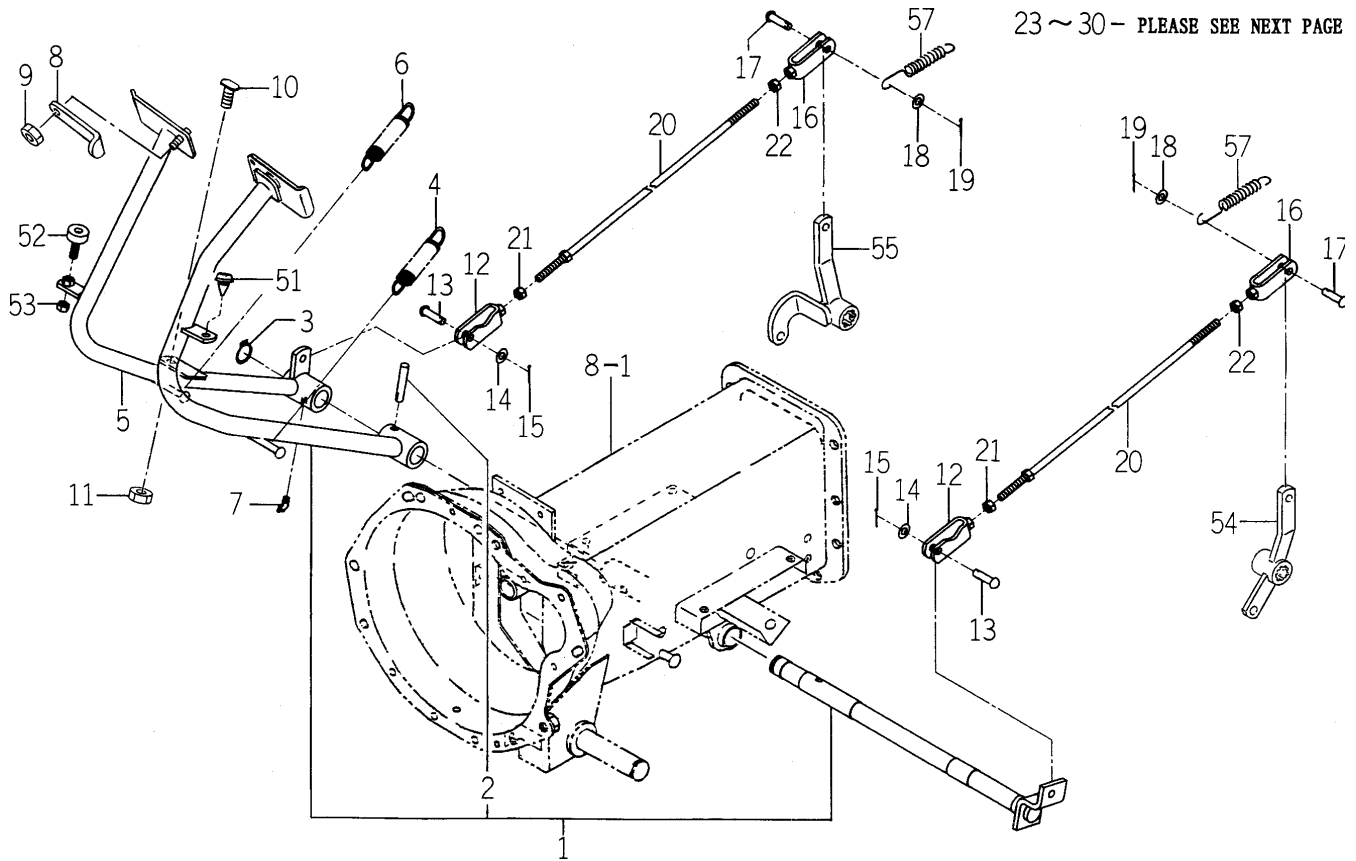

1738-312 -0100

KEY	PART CODE	DESCRIPTION	S P C	TYPE OF MODEL		I T C	C O L	G R P	REMARKS
				TM3160					
1	1738-312-320-20	PEDAL/BRAKE/LH SET	*	1					
2	V511-100-805-00	PIN,TAPER/8X50	*	1					
3	V704-140-022-00	RING,SNAP/22 C	*	1					
4	1673-314-001-00	SPRING/HE106	*	1					
5	1738-312-220-10	PEDAL/BRAKE/RH COMP	*	1					
6	1673-314-001-00	SPRING/HE106	*	1					
7	V763-150-000-00	NIPPLE,GREASE/PT1/8	*	1					
8	1675-312-051-00	LOCKPLATE	*	1					
9	P120-605-031-00	U-NUT	*	1					
10	1688-312-001-10	BOLT/ADJUST	*	1					
11	V304-260-008-00	NUT	*	1					
12	1415-312-500-00	YOKE,LH	*	2					
13	1404-312-006-00	PIN,YOKE A	*	2					
14	V411-260-008-00	WASHER,PL/M 8	*	2					
15	V500-162-002-00	PIN,SPLIT/2 X20	*	2					
16	1510-328-260-00	YOKE COMP	*	2					
17	1404-312-006-00	PIN,YOKE A	*	2					
18	V411-260-008-00	WASHER,PL/M 8	*	2					
19	V500-162-002-00	PIN,SPLIT/2 X20	*	2					
20	1738-312-310-00	ROD/355 COMP	*	2					
21	1560-132-007-30	NUT/M8	*	2					
22	V304-260-008-00	NUT	*	2					
23	1740-313-300-00	LEVER/PARKING ASSY	*	1					
24	1442-313-202-00	ROD	*	1					
25	1444-328-273-00	SPRING	*	1					
26	1444-328-272-00	BUTTON	*	1					
27	1740-313-301-00	GRIP/ORANGE	*	1					
28	V211-360-802-50	BOLT/SP	*	2					
29	1738-312-280-00	ROD/115 COMP	*	1					
30	1738-312-290-00	ROD/70 COMP	*	1					

FIG. 29 PEDAL (BRAKE) SYSTEM(2/2)

51•52•53- PLEASE SEE PRECEDING PAGE

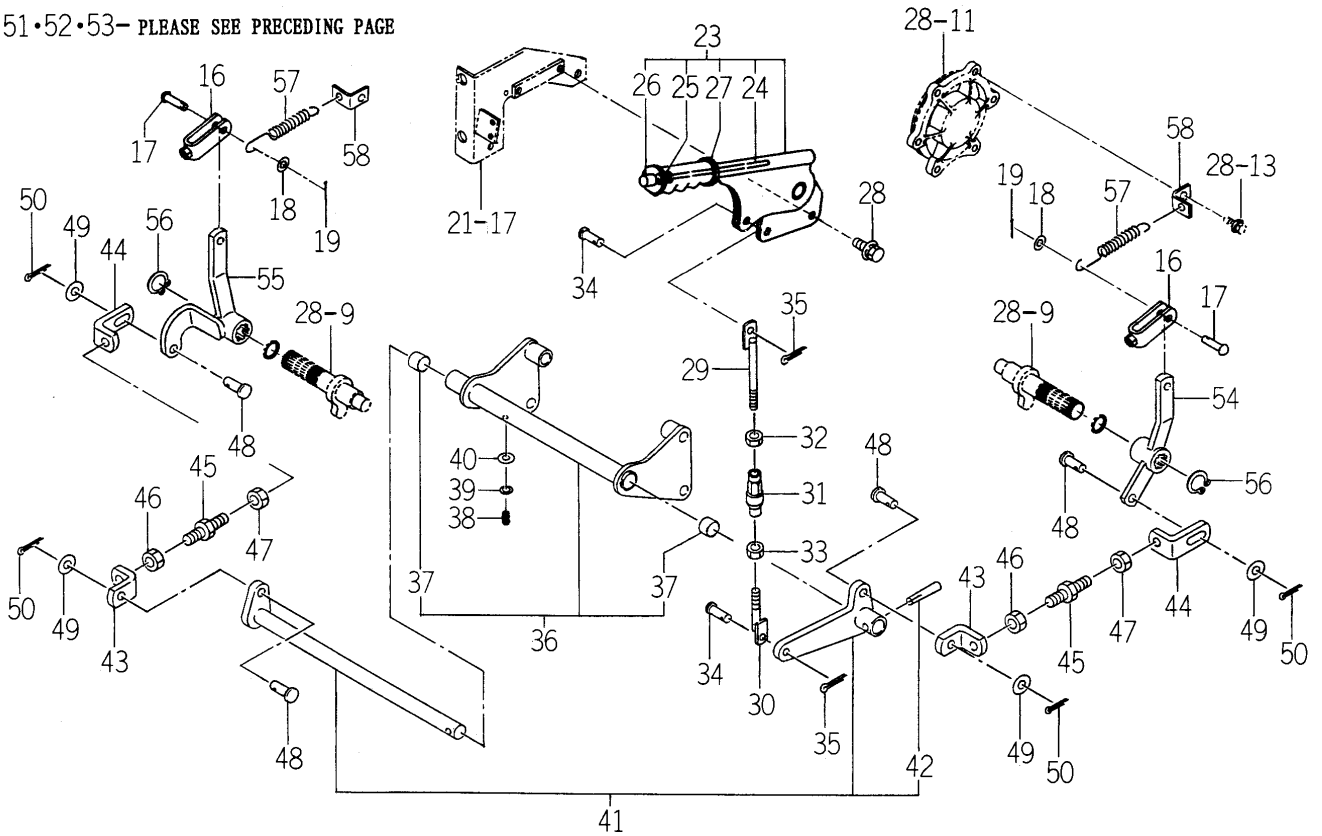

1738-312-0100

KEY	PART CODE	DESCRIPTION	S P C	TYPE OF MODEL		I T C	C O L	G R P	REMARKS
				TM3160					
31	1444-122-002-00	TURNBUCKLE/M8	*	1					
32	V304-260-008-00	NUT	*	1					
33	1560-132-007-30	NUT/M8	*	1					
34	1673-730-008-00	PIN/08X19	*	2					
35	V500-162-002-00	PIN,SPLIT/2 X20	*	2					
36	1738-312-300-10	HOLDER/SHAFT ASSY	*	1					
37	3668-612-001-00	BUSH	*	2					
38	V760-150-000-00	NIPPLE,GREASE	*	1					
39	V401-160-006-00	WASHER,SP/M 6	*	1					
40	V411-260-006-00	WASHER / M6	*	1					
41	1738-312-200-00	SHAFT/BRAKE SET	*	1					
42	V511-100-805-00	PIN,TAPER/8X50	*	1					
43	1738-312-005-00	PLATE/PARKING/A	*	2					
44	1738-312-006-00	PLATE/PARKING/B	*	2					
45	1738-312-007-00	ROD/M12X66	*	2					
46	V304-260-012-00	NUT/M12	*	2					
47	2146-360-014-00	NUT/M12/LH	*	2					
48	1627-122-008-00	PIN/10X25	*	4					
49	V411-260-010-00	WASHER/M10	*	4					
50	V500-162-502-00	PIN,SPLIT/2.5X20	*	4					
51	1432-616-002-00	RUBBER,CUSHION	*	1					
52	1560-630-024-00	INSULATOR	*	1					
53	V304-260-008-00	NUT	*	1					
54	1738-312-240-00	ARM/BRAKE/LH COMP	*	1					
55	1738-312-260-00	ARM/BRAKE/RH COMP	*	1					
56	V704-140-022-00	RING,SNAP/22 C	*	2					
57	3659-480-003-00	SPRING/HE110	*	2					
58	1738-312-009-00	PLATE/L/28X28	*	2					

FIG. 31 STEERING (MANUAL) SYSTEM

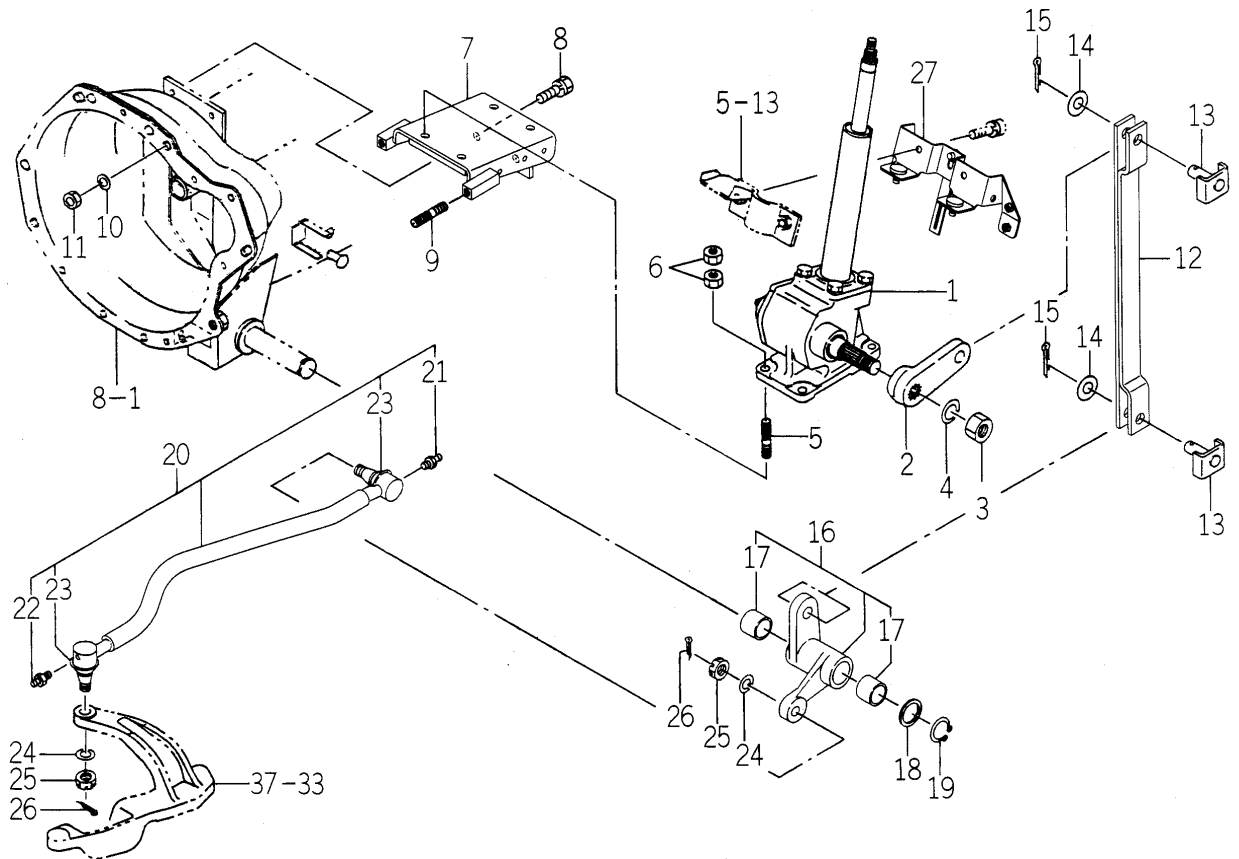

1738-406-0100

KEY	PART CODE	DESCRIPTION	S P C	TYPE OF MODEL		I T C	C O L	G R P	REMARKS
				TM3160					
1	1682-406-210-10	CASE/STEERING ASSY	*	1					FIG 072
2	1672-406-201-00	ARM/PITMAN	*	1					
3	V334-260-020-00	NUT	*	1					
4	V401-160-020-00	WASHER,SP/M20	*	1					
5	1672-406-005-00	BOLT/STUD/M10X35	*	4					
6	V334-460-010-00	NUT/M10 7T P=1.25	*	8					
7	1738-406-200-00	BRACKET/STEERIN COMP	*	1					
8	V211-561-002-00	BOLT/M10X20	*	2					
9	V251-341-003-00	BOLT/STUD	*	2					
10	V401-160-010-00	WASHER,SP/M10	*	2					
11	V304-460-010-00	NUT/M10	*	2					
12	1738-406-210-00	ROD/STEERING COMP	*	1					
13	1726-406-260-00	PIN/15X42 COMP	*	2					
14	V411-260-014-00	WASHER,PL/M14	*	2					
15	V500-162-502-50	PIN,SPLIT/2.5X25	*	2					
16	1672-406-230-00	ARM/STEERING ASSY	*	1					
17	1593-402-051-10	BUSH/25X28X25	*	2					
18	1612-406-001-00	WASHER/26X35X02	*	1					
19	V704-140-025-00	RING,SNAP/25 C	*	1					
20	1738-406-240-00	ROD/DRA G ASSY	*	1					
21	1404-402-005-00	NIPPLE,GREASE	*	1					
22	1404-402-005-00	NIPPLE,GREASE	*	1					
23	1427-406-018-00	COVER,DUST	*	2					
24	V401-160-010-00	WASHER,SP/M10	*	2					
25	V327-262-110-00	NUT/M10X1.25	*	2					
26	V500-162-502-00	PIN,SPLIT/2.5X20	*	2					
27	1738-406-230-00	BRACKET/REAR COMP	*	1					

FIG. 37 FINAL GEAR CASE SYSTEM

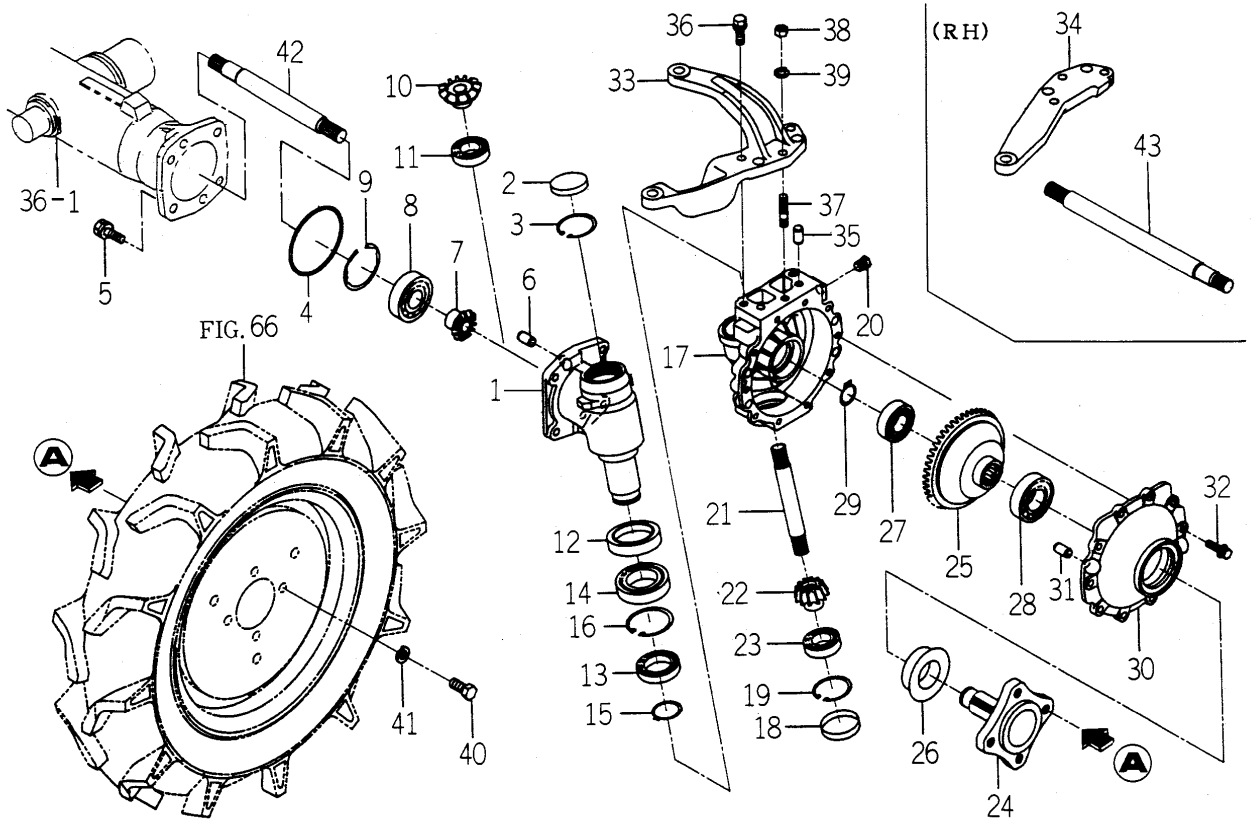

1726-434-0100,1703-435-0100

KEY	PART CODE	DESCRIPTION	S P C	TYPE OF MODEL		I T C	C O L	G R P	REMARKS
				TM3160					
1	1672-434-009-00	CASE/FINAL	*	2					
2	1564-201-003-00	CAP/SEAL/47	*	2					
3	V705-140-047-00	RING,SNAP/47 C	*	2					
4	V721-103-109-00	O-RING/G90	*	2					
5	V211-561-003-00	BOLT/M10X30	*	8					
6	V523-101-002-40	PIN	*	4					
7	1703-434-003-00	GEAR/BEVEL/11	*	2					
8	V600-110-630-50	BEARING,RB/6305	*	2					
9	V707-140-062-00	RING/SNAP	*	2					
10	1703-434-004-00	GEAR/BEVEL/15	*	2					
11	V600-110-600-50	BEARING,RB/6005	*	2					
12	1488-413-023-10	SEAL,OIL	*	2					
13	V600-110-690-70	BEARING	*	2					
14	V600-110-600-80	BEARING,RB/6008	*	2					
15	V704-140-035-00	RING,SNAP/35 C	*	2					
16	V707-140-055-00	RING/SNAP	*	2					
17	1672-434-011-10	CASE/FINAL	*	2					
18	1564-201-003-00	CAP/SEAL/47	*	2					
19	V705-140-047-00	RING,SNAP/47 C	*	2					
20	V782-160-000-4B	PLUG/SCREW/SEAL	*	4					
21	1612-434-006-00	SHAFT	*	2					
22	1672-434-007-00	GEAR/BEVEL/12	*	2					
23	V600-110-600-50	BEARING,RB/6005	*	2					
24	1681-434-002-10	SHAFT/WHEEL	*	2					
25	1672-434-008-00	GEAR/BEVEL/47	*	2					
26	1491-434-017-00	SEAL/QLNY35571116	*	2					
27	V600-110-620-50	BEARING,RB/6205	*	2					
28	V600-110-620-60	BEARING,RB/6206	*	2					
29	V704-140-025-00	RING,SNAP/25 C	*	2					
30	1612-434-009-00	COVER/WHEEL	*	2					

FIG. 39 CASE (CYLINDER) SYSTEM

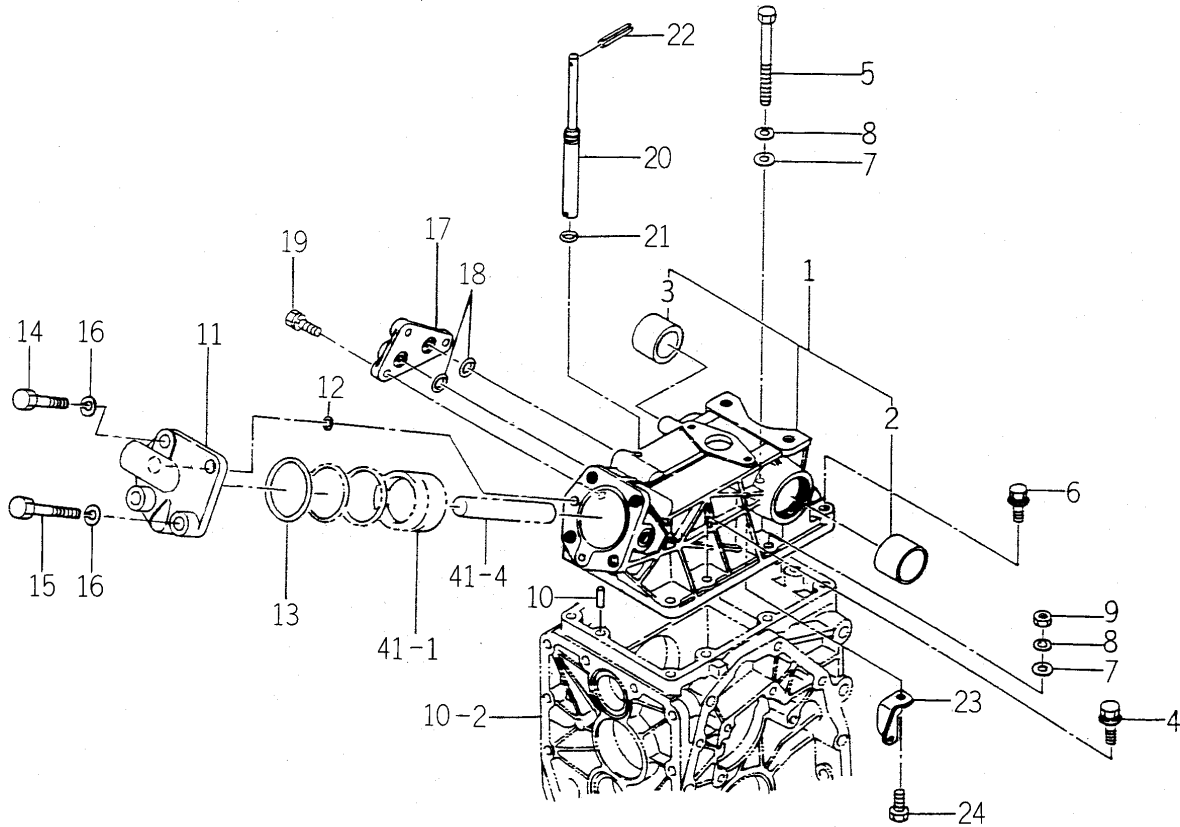

1738-501-0100

KEY	PART CODE	DESCRIPTION	S P C	TYPE OF MODEL		I T C	C O L	G R P	REMARKS
				TM3160					
1	1579-501-200-00	CASE, SYLINDER	*	1					
2	1480-501-003-00	BUSH/40X43X30	*	1					
3	1427-501-003-00	BUSH/35X39X30	*	1					
4	V211-361-004-00	BOLT, SEMS	*	4					
5	V201-261-010-00	BOLT/M10X100	*	1					
6	V211-361-004-50	BOLT/M10X45	*	2					
7	V411-260-010-00	WASHER/M10	*	3					
8	V401-160-010-00	WASHER, SP/M10	*	3					
9	V304-260-010-00	NUT	*	2					
10	V522-100-801-80	PIN	*	2					
11	1717-501-002-00	HEAD/CYLINDER	*	1					
12	V720-112-401-20	O-RING/P12	*	2					
13	V721-113-106-00	O-RING G60	*	1					
14	V201-361-204-00	BOLT/M12X40	*	2					
15	V201-361-206-00	BOLT	*	2					
16	V401-160-012-00	WASHER, SP/M12	*	4					
17	1434-501-003-10	SUBCONCOVER	*	1					
18	V720-112-401-20	O-RING/P12	*	3					
19	V211-260-802-50	BOLT/S	*	3					
20	1738-501-001-00	PIN/ADJUST	*	1					
21	V720-101-900-70	O-RING/P 7	*	1					
22	V580-140-403-60	PIN, SPRING 3X32	*	1					
23	1434-501-005-00	HOOK, SPRING	*	1					
24	V201-260-801-60	BOLT/M 8X16	*	1					

FIG. 41 CYLINDER SYSTEM

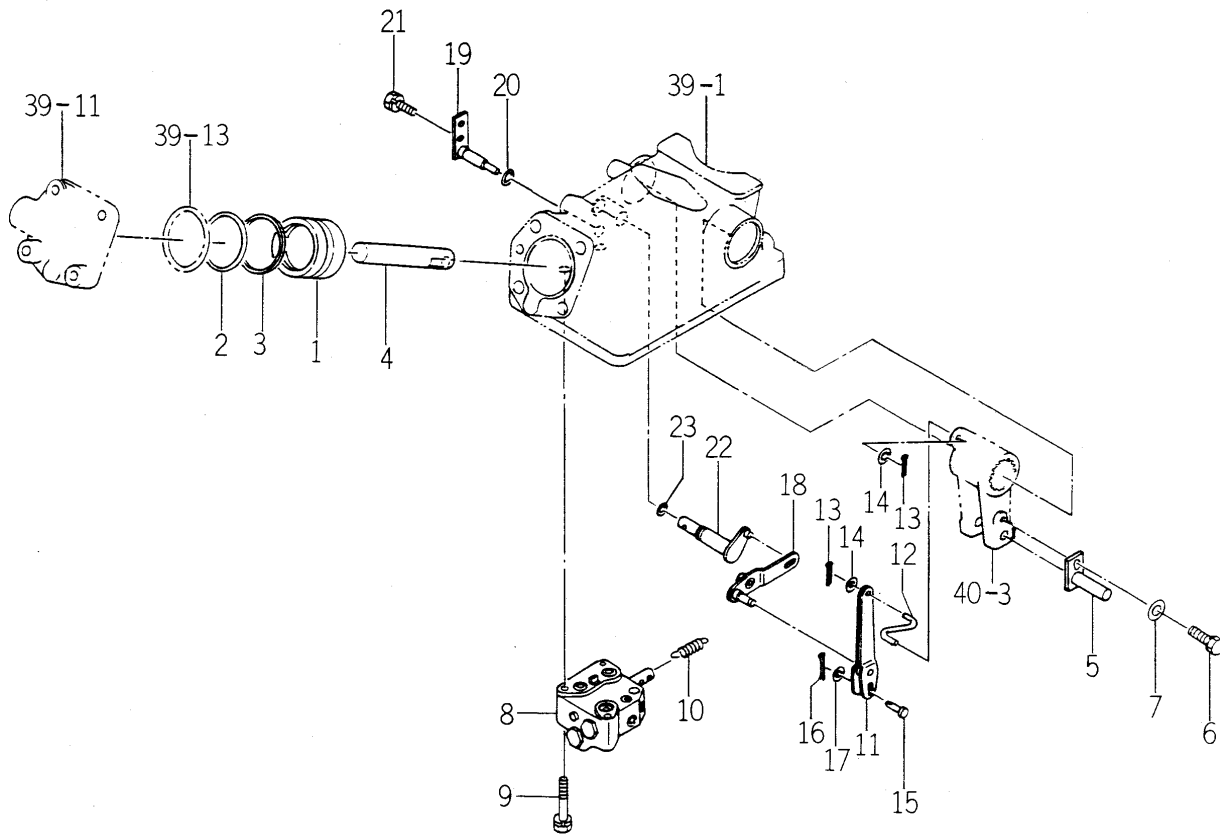

1738-503-0100

KEY	PART CODE	DESCRIPTION	S P C	TYPE OF MODEL		I T C	C O L	G R P	REMARKS
				TM3160					
1	1421-507-002-10	PISTON	*	1					
2	V720-105-705-50	O-RING/P55	*	1					
3	1416-501-011-00	RING, BACKUP	*	1					
4	1544-503-001-20	ROD	*	1					
5	1544-503-200-20	PIN, ROD COMP	*	1					
6	V211-561-001-60	BOLT(S)7	*	1					
7	V411-260-010-00	WASHER/M10	*	1					
8	K211-001-000-00	VALVE CONTROL ASSY	*	1					FIG 071
9	V211-260-805-00	BOLT/M8X50	*	3					
10	1434-501-006-00	SPRING, TENSION/31	*	1					
11	1717-503-200-10	LINK/SPOOL COMP	*	1					
12	1434-503-001-00	LINK, CRANK	*	1					
13	V500-162-001-50	PIN, SPLIT/2 X15	*	2					
14	V411-260-006-00	WASHER / M6	*	2					
15	1434-503-002-00	PIN/5X17	*	1					
16	V500-162-001-50	PIN, SPLIT/2 X15	*	1					
17	V411-260-005-00	WASHER	*	1					
18	1672-503-210-00	LINK/SUPPORT COMP	*	1					
19	1434-503-250-10	PIN/SUPPORT COMP	*	1					
20	V720-101-900-70	O-RING/P 7	*	1					
21	V211-260-801-60	BOLT, SEMS (S) M8X16	*	1					
22	1434-503-260-20	LINK SHIFT ARM	*	1					
23	V720-102-401-00	O-RING/P10A	*	1					

FIG. 43 PIPING SYSTEM

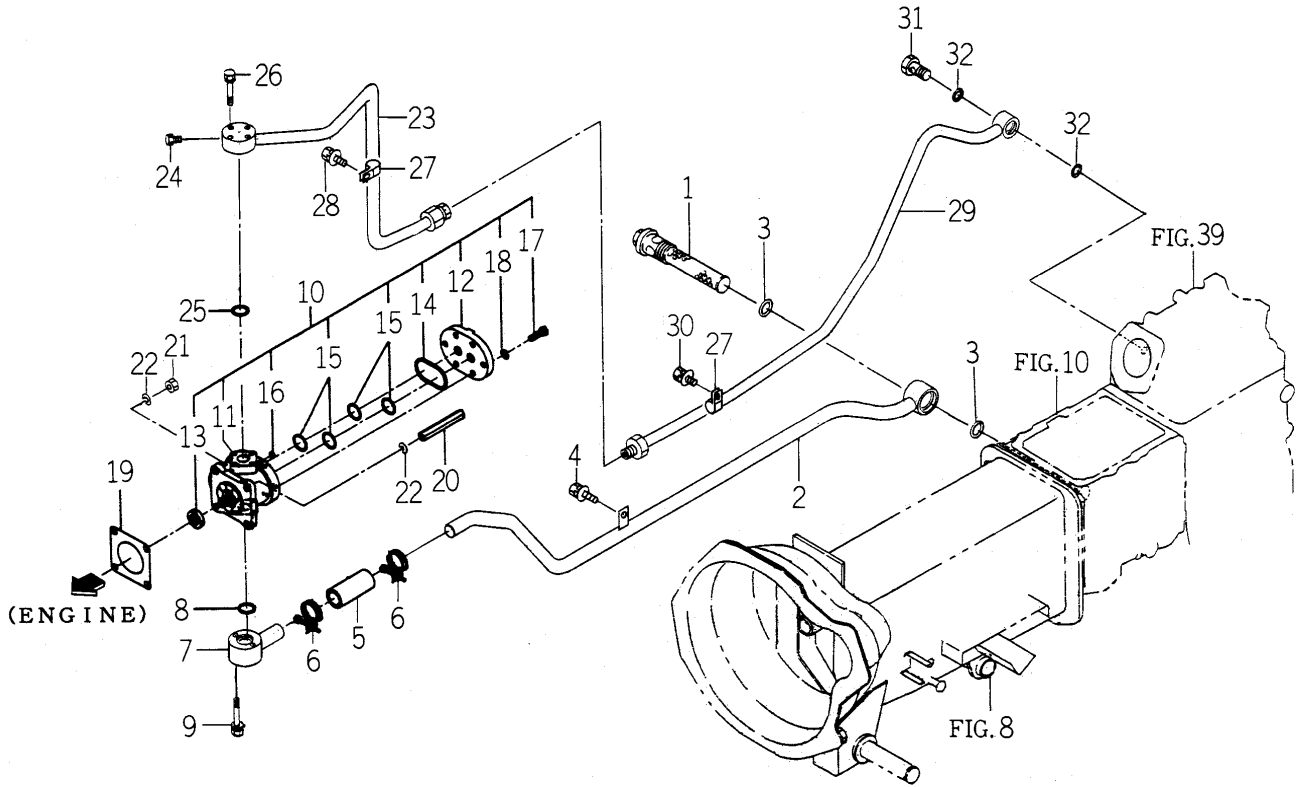

1738-508-0100

KEY	PART CODE	DESCRIPTION	S P C	TYPE OF MODEL		I T C	C O L	G R P	REMARKS
				TM3160					
1	1738-508-210-00	FILTER/SUCTION COMP	*	1					
2	1738-508-220-00	PIPE/SUCTION/REAR	*	1					
3	V720-113-502-80	RING/O	*	2					
4	V211-360-801-60	BOLT,SEMS (SP)	*	1					
5	1675-508-004-00	HOSE/70	*	1					
6	J061-224-032-00	CLAMP/WIRE/24-32	*	2					
7	1726-508-230-00	PIPE/SUC/FRONT COMP	*	1					
8	V720-112-402-00	O-RING/P20	*	1					
9	V210-560-604-50	BOLT/S	*	2					
10	K135-023-000-00	PUMP GEAR ASSY	*	1					
11	K135-023-100-00	GEAR PUMP SET	*	1					
12	K135-017-006-00	COVER,PUMP	*	1					
13	V744-114-280-70	SEAL,OIL	*	1					
14	V721-113-105-00	O-RING HS90 G50	*	1					
15	V720-112-402-20	O-RING/P22	*	4					
16	V720-111-900-60	O-RING P6 HS90	*	1					
17	K135-002-009-00	BOLT/M8X28 11T	*	6					
18	V401-170-008-00	S.W	*	6					
19	1404-503-006-00	PACKING,OIL PUMP	*	1					
20	1560-515-004-50	NUT/M08	*	1					
21	V304-260-008-00	NUT	*	3					
22	V401-160-008-00	WASHER,SP/M 8	*	4					
23	1738-508-230-00	PIPE/DELIVERY/FRONT	*	1					
24	V782-160-000-2T	PLUG/SCREW/SEAL	*	1					
25	V720-112-402-00	O-RING/P20	*	1					
26	V210-560-603-00	BOLT/S	*	4					
27	1675-508-003-00	HOLDER/15	*	2					
28	V211-360-801-60	BOLT,SEMS (SP)	*	1					
29	1738-508-240-00	PIPE/DELIVERY/REAR	*	1					
30	V211-360-801-60	BOLT,SEMS (SP)	*	1					

FIG. 44 LINK (3P) SYSTEM

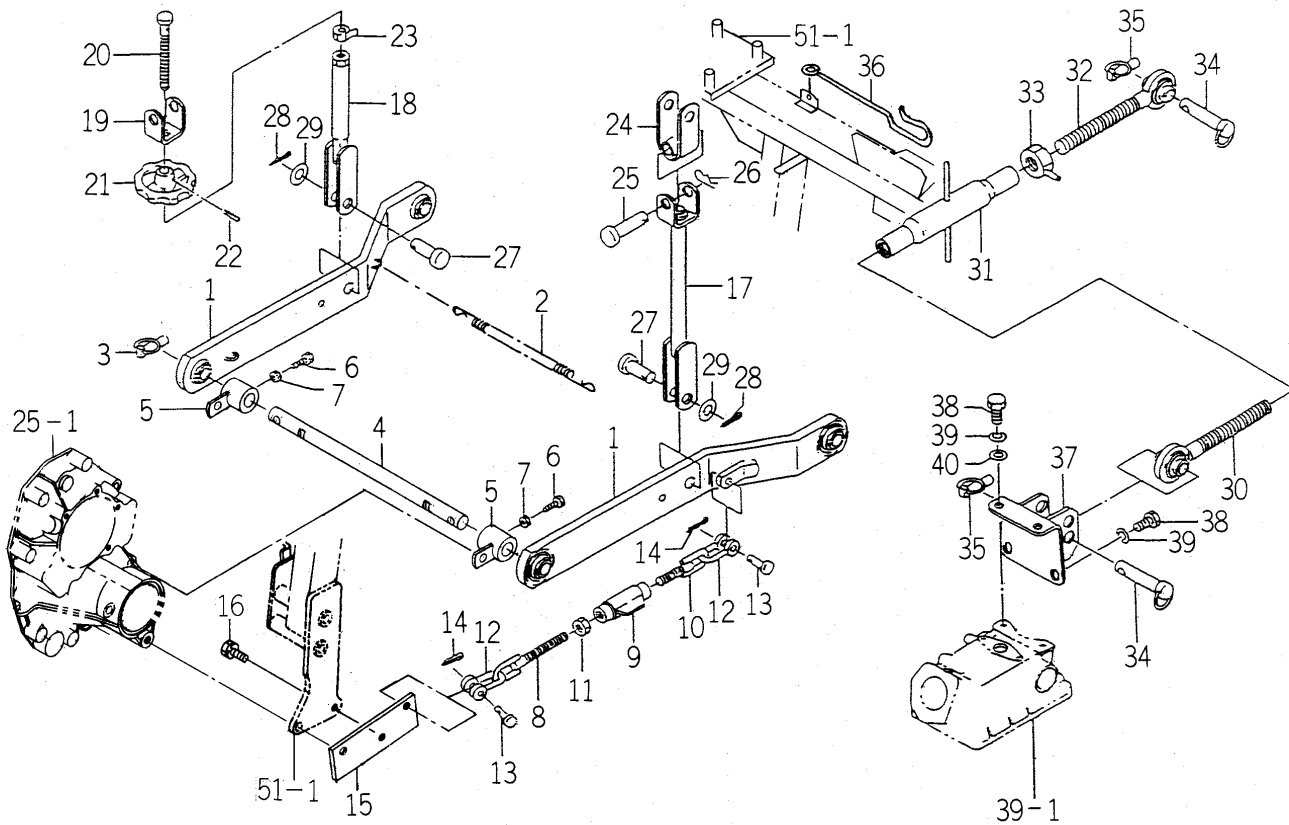

1738-514 -0100

KEY	PART CODE	DESCRIPTION	S P C	TYPE OF MODEL		I T C	C O L	G R P	REMARKS
				TM3160					
1	1435-511-250-10	LINK/LOWER COMP	*	2					
2	1560-525-001-40	SPRING	*	1					
3	1673-525-002-20	LINKPIN	*	2					
4	1738-514-001-00	PIN/22X404	*	1					
5	1738-514-210-00	HUB/SPACER COMP	*	2					
6	V201-360-802-50	BOLT/M 8X25	*	2					
7	V305-260-008-00	NUT/M 8	*	2					
8	1435-511-270-00	CHAIN/CHECK/148 COMP	*	2					
9	1427-511-320-00	TURNBUCKLE 12 COMP	*	2					
10	1427-511-220-00	CHAIN,CHECK RH	*	2					
11	V305-260-012-00	NUT/M12	*	2					
12	1427-511-002-00	SHACKLE	*	4					
13	1427-511-001-00	PIN/10X32	*	4					
14	V500-162-502-00	PIN,SPLIT/2.5X20	*	4					
15	1738-514-002-00	STAY/PLATE	*	2					
16	V211-561-003-00	BOLT/M10X30	*	2					
17	1427-511-270-00	ROD/LIFT/LH COMP	*	1					
18	1427-511-290-00	ROD/LIFT/RH COMP	*	1					
19	1427-511-273-00	FORK	*	1					
20	1427-511-003-00	SCREW	*	1					
21	1427-511-004-00	HANDLE/ADJUST	*	1					
22	V580-140-503-20	PIN,SPRING/5 X32 W	*	1					
23	1427-511-280-00	NUT,LOCK/16	*	1					
24	1427-511-300-00	FORK/BRACKET COMP	*	2					
25	1423-520-001-10	PIN/16X63	*	2					
26	1305-931-003-00	PIN,HAIR	*	2					
27	1427-511-005-00	PIN/16X44	*	2					
28	V500-164-002-50	PIN,SPLIT/4 X25	*	2					
29	V411-260-016-00	WASHER / M16	*	2					
30	1427-511-250-10	LINK, TOP LH COMP	*	1					