

**Technical data**  
**Hydraulic crawler crane**

**HS 895 HD**  
Litronic®

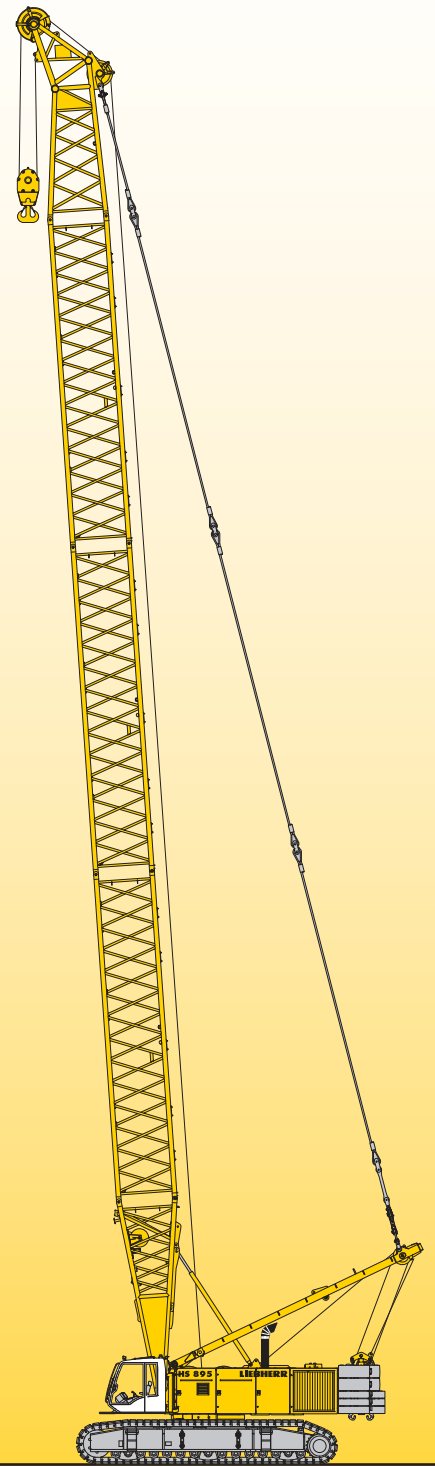

**LIEBHERR**

# Dimensions

## Basic machine with undercarriage

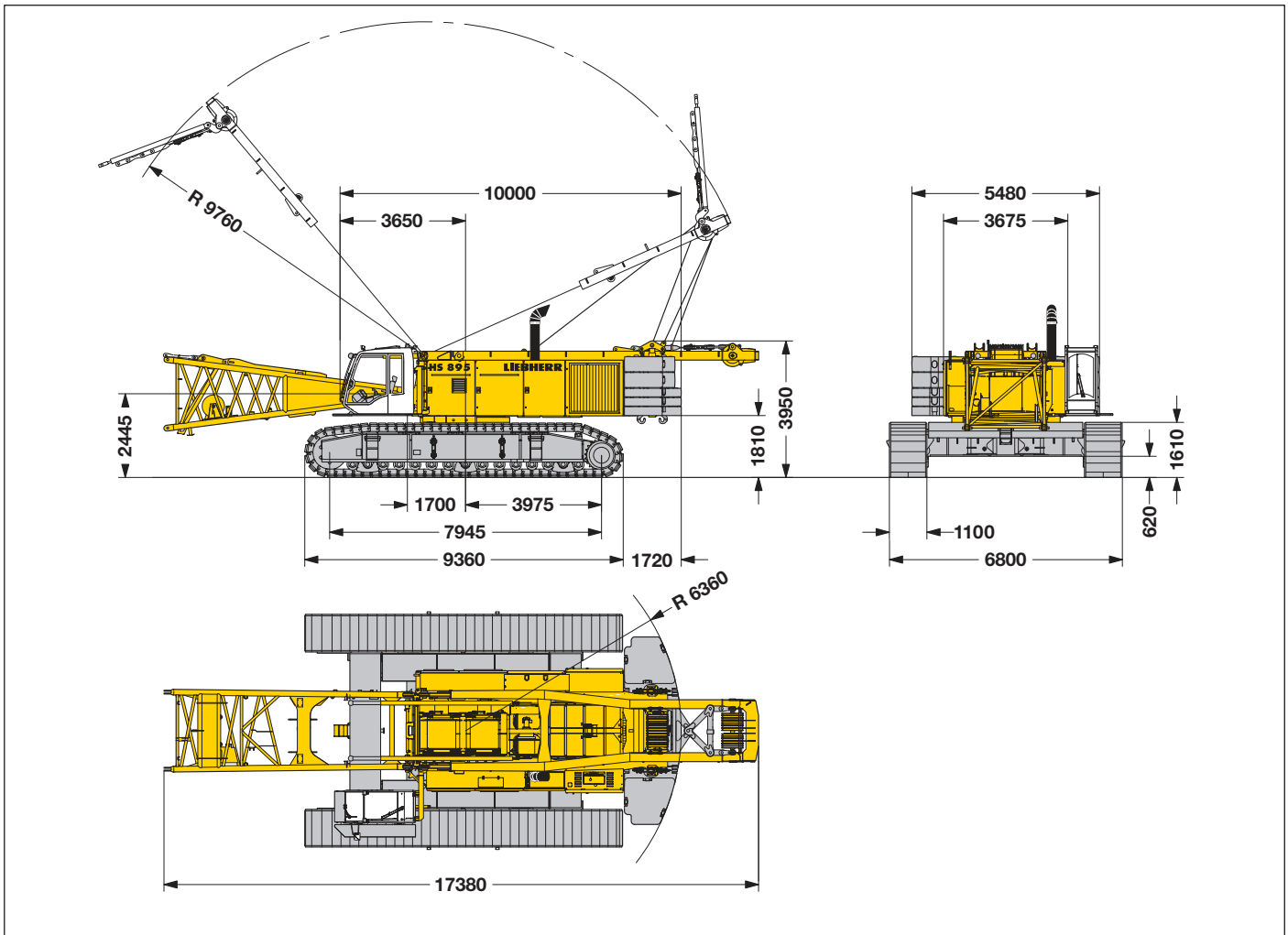

### Operating weight

The operating weight includes the basic machine with HD undercarriage, 2 main winches 350 kN including wire ropes (150 m) and 20 m main boom, consisting of A-frame, boom foot (7 m), boom head (7 m) and boom section (6 m), 55.1 t basic counterweight, 1100 mm track pads and 60 t hook block.

Total weight \_\_\_\_\_ approx. 172.2 t

### Ground pressure

Ground bearing pressure \_\_\_\_\_ 0.98 kg/cm<sup>2</sup>

### Equipment

Main boom (No. 2220) max. length \_\_\_\_\_ 84.2 m  
 Fixed jib (No. 1008) \_\_\_\_\_ 11 m - 26 m  
 Modular designed equipment for operation as crane, with dragline or clamshell.

For dragline operation, a rotating fairlead is fitted into the boom foot. This minimizes the rope angle to drum, which results in lower rope wear.

### Remarks

1. The lifting capacities stated are valid for lifting operation only (corresponding with crane classification according to F.E.M. 1.001, crane group A1).
2. Crane standing on firm, horizontal ground.
3. The weight of the lifting device (hoisting ropes, hook block, shackle etc.) must be deducted from the gross lifting capacity to obtain a net lifting value.
4. Additional equipment on boom (e.g. boom walkways, auxiliary jib) must be deducted to get the net lifting capacity.
5. For max. wind speed please refer to lift chart in operator's cab or manual.
6. Working radii are measured from center of swing and under load.
7. The lifting capacities are valid for 360 degrees of swing.
8. Calculation of stability under load is based on ISO 4305 Table 1 + 2, tipping angle 4°.
9. The structures are calculated according to F.E.M. 1.001 - 1998 (EN 13001-2 / 2004).

# Transport dimensions and weights

## Basic machine and boom (No. 2220.xx)

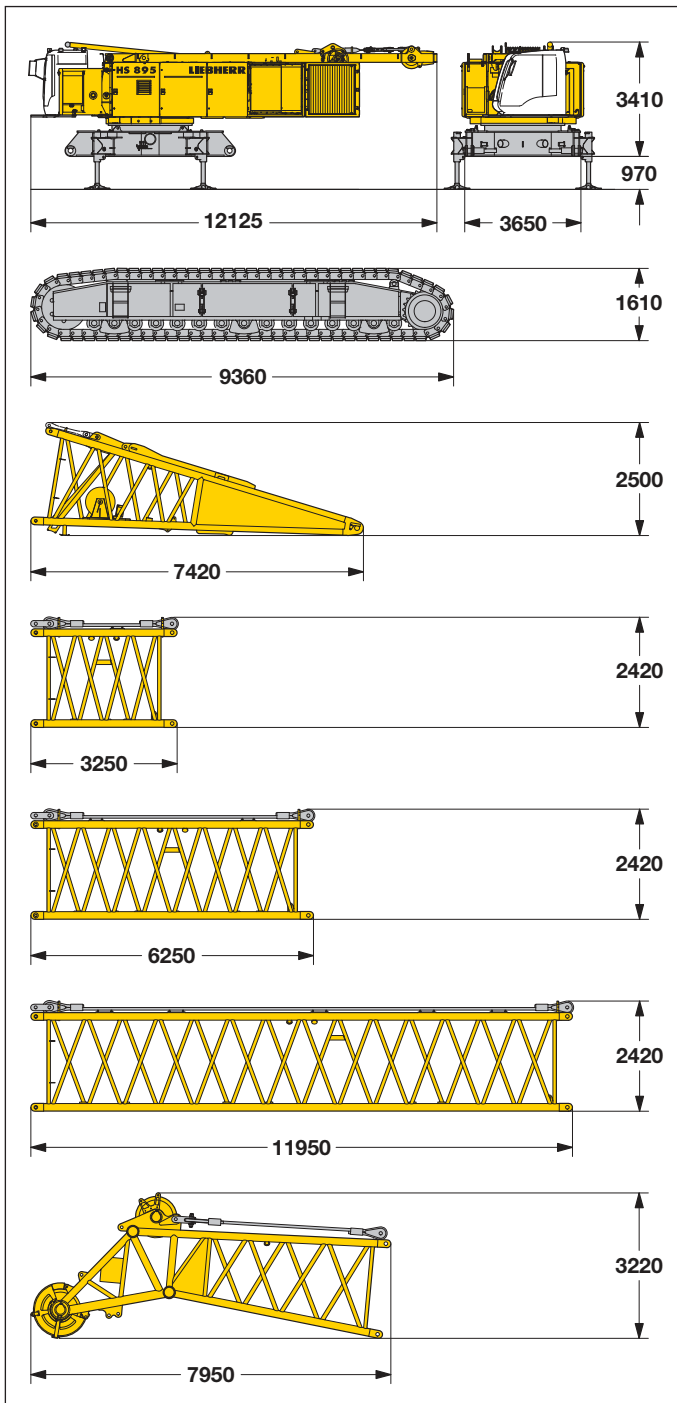

\*) Including carbon fibre pendant strap, without auxiliary equipment

### Basic machine

with A-frame, 2 x 350 kN winches including wire ropes (150 m), without crawlers, boom foot, basic and carbody counterweight

Width	3500 mm
Weight including jack-up system (1.7 t)	60700 kg

### Crawler

**2x**

Track pads	1100 mm
Width	1450 mm
Weight*	25510 kg

### Boom foot (No. 2220.30)

Width	2420 mm
Weight*	3720 kg

### Boom section (No. 2220.24)

**3 m**

Width	2420 mm
Weight*	1030 kg

### Boom section (No. 2220.24)

**6 m**

Width	2420 mm
Weight*	1630 kg

### Boom section (No. 2220.22)

**11.7 m**

Width	2420 mm
Weight*	2380 kg

### Boom head<sup>1)</sup> (No. 2220.24)

Width	2420 mm
Weight*	4250 kg

1) Polyamide sheaves

# Transport dimensions and weights

## Fixed jib (No. 1008.xx)

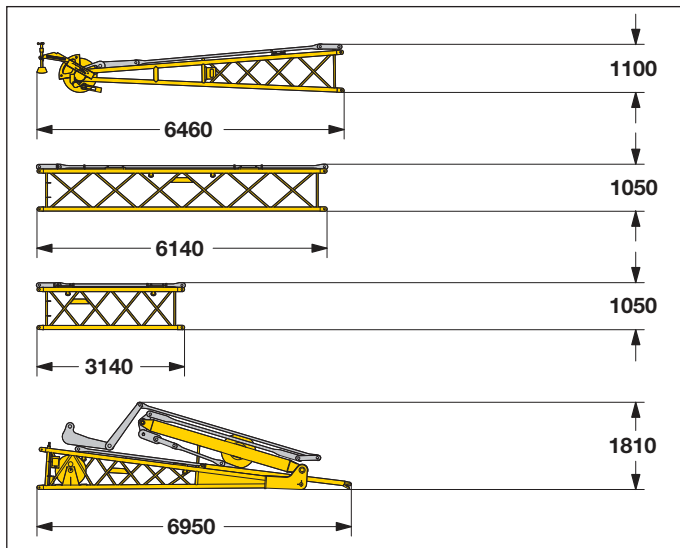

\*) Including pendant ropes

### Fixed jib head (No. 1008.20)

Width	1095 mm
Weight*	950 kg

### Fixed jib section (No. 1008.17) **6 m**

Width	1200 mm
Weight*	455 kg

### Fixed jib section (No. 1008.17) **3 m**

Width	1200 mm
Weight*	270 kg

### Fixed jib foot with A-frame (No. 1008.20)

Width	2700 mm
Weight*	2350 kg

## Counterweight

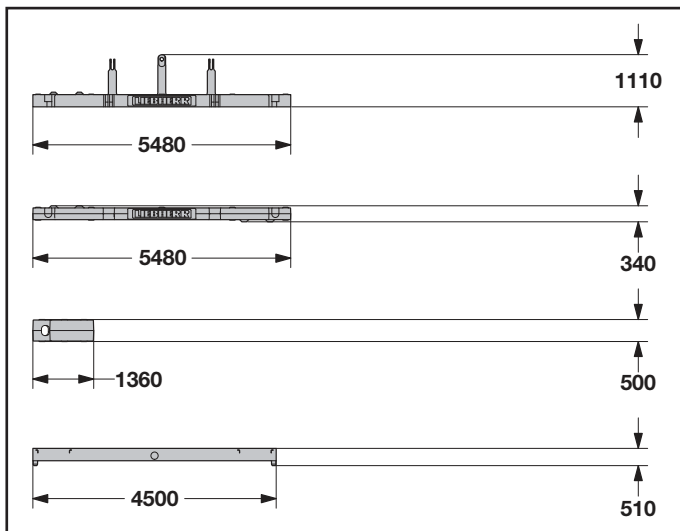

### Counterweight **1x**

Width	1660 mm
Weight	13200 kg

### Counterweight **2x**

Width	1660 mm
Weight	10600 kg

### Counterweight (optional 8x) **4x**

Width	1480 mm
Weight	5100 kg

### Counterweight optional **2x**

Width	1200 mm
Weight	13500 kg

## Hooks

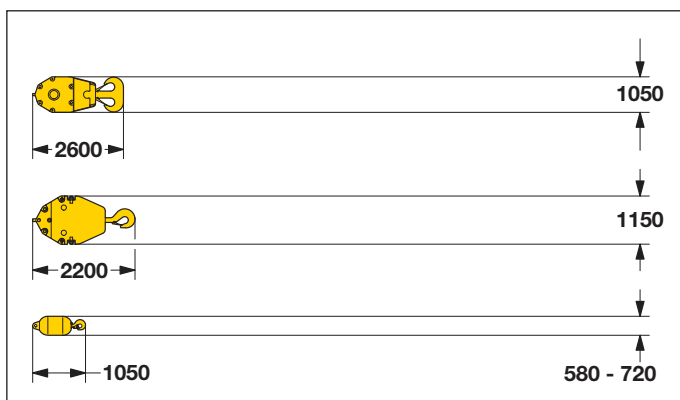

### 200 t hook block - 3 sheaves

Width	480 mm
Weight	2600 kg

### 120 t hook block - 2 sheaves

Width	400 mm
Weight	1400 kg

### 35 t single hook

Width	400	580	720 mm
Weight	400	800	1200 kg

# Technical description



## Engine

Power rating according to ISO 3046, 670 kW (898 hp) at 1900 rpm  
Engine type \_\_\_\_\_ MAN D 2842 LE  
Fuel tank \_\_\_\_\_ 950 l capacity with continuous level  
\_\_\_\_\_ indicator and reserve warning  
Engine complies with NRMM exhaust certification EPA / CARB Tier 2.



## Hydraulic system

The main pumps are operated by a distributor gearbox. Axial piston displacement pumps work in closed and open circuits supplying oil only when needed (flow control on demand). To minimize peak pressure an automatically working pressure cut-off is integrated. This spares pumps and saves energy. The hydraulic oil is cleaned through electronically controlled pressure and return filters. Possible contamination is signaled in the cabin. The use of synthetic environmentally friendly oils is possible. Ready made hydraulic retrofit kits are available to customize requirements e.g. powering casing oscillators, VM-vibrators, hydraulic grabs, fixed leaders etc.  
Working pressure \_\_\_\_\_ max. 350 bar  
Oil tank capacity \_\_\_\_\_ 1360 l



## Boom winch

Line pull \_\_\_\_\_ max. 150 kN  
Rope diameter \_\_\_\_\_ 24 mm  
Boom up \_\_\_\_\_ 160 sec. from 15° to 86°



## Swing

Consists of rollerbearing with external teeth for lower tooth flank pressure, fixed axial piston hydraulic motor, spring loaded and hydraulically released multi-disc holding brake, planetary gearbox and pinion. Swing speed from 0 – 3.6 rpm continuously variable, selector for 3 speed ranges to increase swing precision.

Standard:

Second swing drive

Option:

Third swing drive



## Noise emission

Noise emissions correspond with 2000/14/EC directive on noise emission by equipment used outdoors.



## Main winches

Winch options:  
Line pull (nom. load) \_\_\_\_\_ 350 kN  
Rope diameter \_\_\_\_\_ 36 mm  
Drum diameter \_\_\_\_\_ 830 mm  
Rope speed \_\_\_\_\_ 0-77 m/min  
With change gear box \_\_\_\_\_ 0-157 m/min  
Rope capacity 1st layer \_\_\_\_\_ 46.9 m

The winches are outstanding in their compact design and easy assembly. Clutch and braking functions on the free-fall system are provided by a compact designed, low wear and maintenance-free multi-disc brake.

The drag and hoist winches use pressure controlled, variable flow hydraulic motors. This system features sensors that automatically adjust oil flow to provide max. winch speed depending on load.

Option:

Auxiliary winch \_\_\_\_\_ 70 kN in boom foot  
Tagline winch \_\_\_\_\_ 70 kN with free fall  
\_\_\_\_\_ 30 kN with free fall



## Crawlers

The track width of the undercarriage is changed hydraulically. Propulsion through axial piston motor, hydraulically released spring loaded multi-disc brake, maintenance-free crawler tracks, hydraulic chain tensioning device.

Track pads \_\_\_\_\_ 1100 mm  
Drive speed (2-speed hydraulic motor) \_\_\_\_\_ 1st gear 0.75 km/h  
\_\_\_\_\_ 2nd gear 1.40 km/h

Option:

- Jack-up system
- Self-assembly system



## Control

The control system – developed and manufactured by Liebherr – is designed to withstand extreme temperature changes and the rough heavy duty tasks common in the construction industry. Complete machine operating data are shown on a high resolution display. The crane is equipped with proportional control for all movements, which can be carried out simultaneously.

On request, Liebherr also offers special custom designed control systems for free-fall winches.

Operation:

Left joy stick for boom winch and swing, right two directional levers for winch I and II. Crawler control is actuated with the two central foot pedals. Additionally, hand levers can be attached to the pedals.

Options:

- Special demolition control system
- MDE: Machine data recording
- PDE: Process data recording
- GSM modem

# Equipment (main boom No. 2220.xx and 55.1 t counterweight)

## Casing oscillator

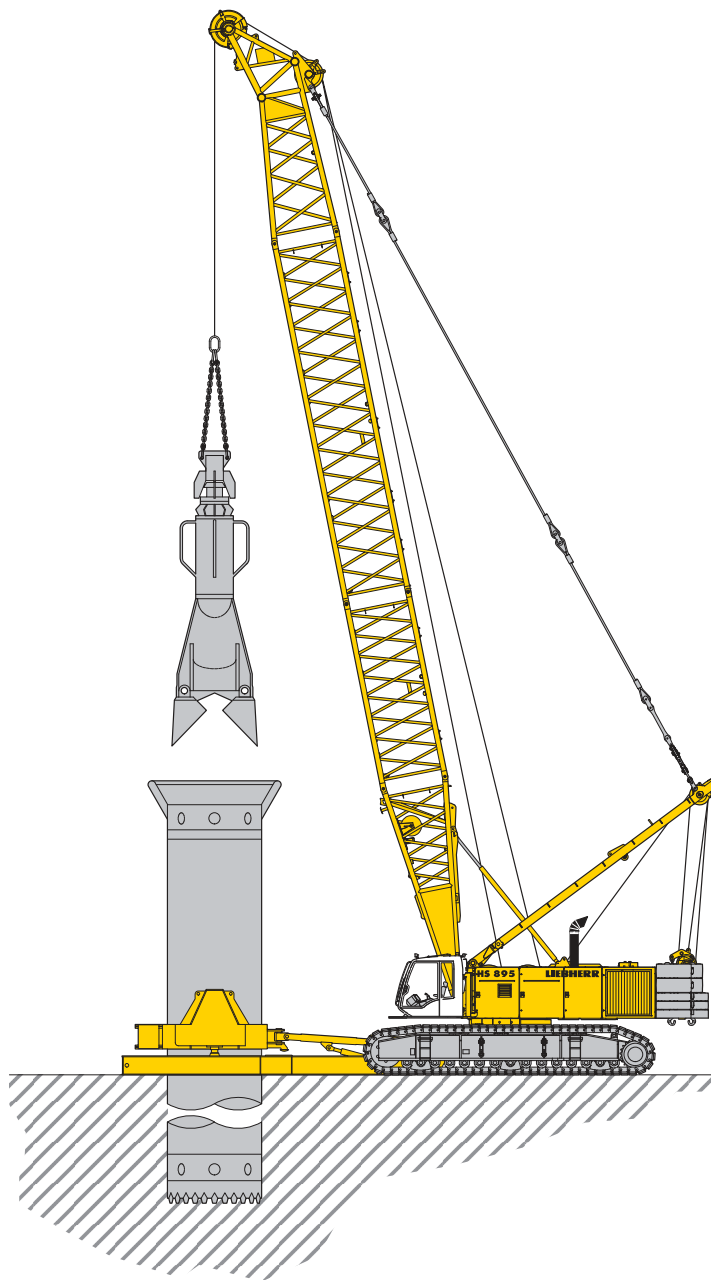

### Casing oscillator\*

Winch options	2 x 350 kN
Line speed 1st gear	0–77 m/min
(with change gear box)	0–157 m/min
Drilling diameter	3300 mm
Max. chisel weight	18 t

\*) Load chart for duty cycle operation see page 8

Free-fall winches with maintenance-free, spring loaded multi-disc brake working in an oil bath. Simultaneous working of both winches is assured through our hydraulic system.

Hydraulic supply for casing oscillator

q = 2x 350 l/min

P = 300 bar max.

Mechanical connection casing oscillator on undercarriage.

Automatic operation for one- and two-rope grabs (optional). During the drilling process the engine power can be freely divided between casing oscillator and hoisting winches as required.

# Equipment (main boom No. 2220.xx and 55.1 t counterweight)

## Dynamic soil compaction

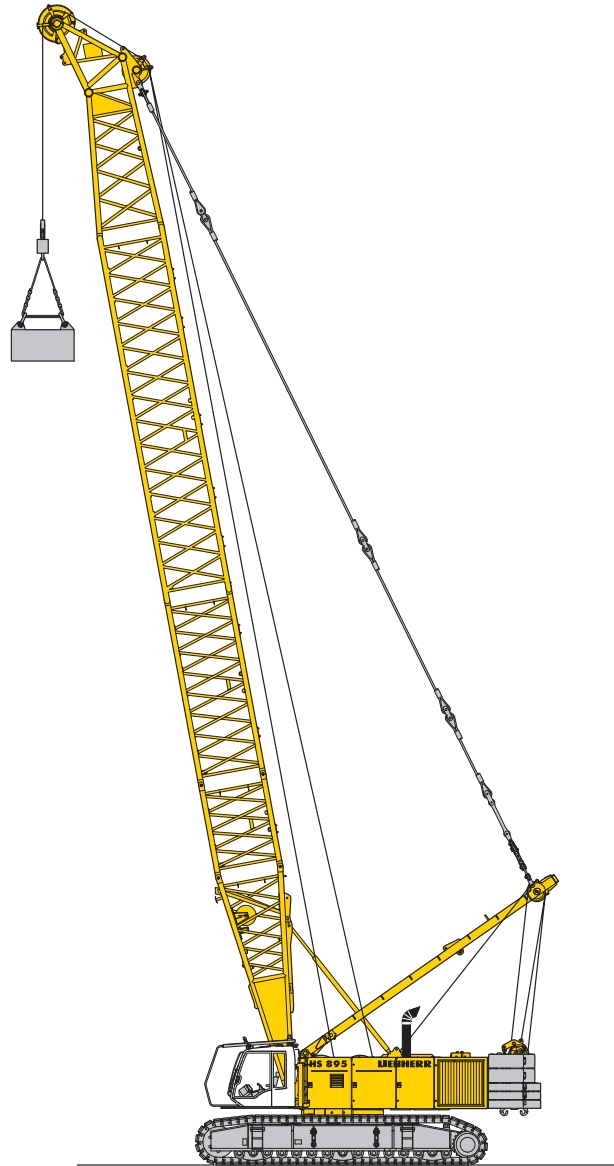

Capacities in metric tons for boom lengths (25.7 m - 43.4 m)

Radius (m)	Boom length			
	25.7 m	31.7 m	37.4 m	43.4 m
	t	t	t	t
9	40	40	40	38
10	40	38	36	34
11	35	35	32	31
12	32	32	30	28

Max. capacities in metric tons do not exceed 75% of tipping load. All loads given are max. values and must not be exceeded. They are only permitted in two-rope automatic operation and are valid for work on a surface with max. inclination of 1%.

Lifting heights must not exceed 30 m.

# Load chart for duty cycle operation (main boom No. 2220.xx)

## 55.1 t counterweight

Capacities in metric tons for boom lengths (20 m - 58.1 m) - with 350 kN winches

Radius (m)	Boom length (m)													Radius (m)	
	20	23	25.7	28.7	31.7	34.7	37.4	40.4	43.4	46.4	49.1	52.1	55.1		58.1
5.6		49.2													5.6
6		49.2	49.2												6
7	49.2	49.2	49.2	49.2	49.2	49.2									7
8	49.2	49.2	49.2	49.2	49.2	49.2	49.2	49.2	49.2						8
9	49.2	49.2	49.2	49.2	49.2	49.2	49.2	49.2	49.2	44.2	36.3	31.7	27.4		9
10	49.2	49.2	49.2	49.2	49.2	49.2	49.2	49.2	49.2	44.2	36.3	31.7	27.4	24.8	10
12	49.2	49.2	49.2	49.2	49.2	49.2	49.2	46.8	45.8	42.7	36.3	31.7	27.4	24.8	12
14	49.2	49.2	49.2	49.2	49.2	49.2	47.4	44.6	40.8	37.4	32.1	29.2	26.5	24.5	14
16	42.3	42.3	42.5	42.4	42.4	42.2	42.2	40.8	37.0	33.5	29.2	26.6	24.8	23.0	16
18	35.9	35.9	36.2	36.1	36.0	35.8	35.8	35.6	34.2	29.7	26.8	24.8	23.5	21.8	18
20	31.0	31.0	31.3	31.2	31.1	30.9	30.9	30.7	29.4	26.9	25.1	23.3	21.8	20.3	20
22		27.1	27.4	27.3	27.2	27.0	27.0	26.8	25.8	24.4	23.2	21.9	20.6	18.9	22
24			24.2	24.1	24.0	23.9	23.9	23.6	22.8	22.0	21.7	20.3	19.1	17.8	24
26				21.5	21.4	21.2	21.3	21.1	20.5	19.8	19.4	18.8	17.9	16.6	26
28				19.2	19.2	19.0	19.1	18.9	18.6	17.8	17.6	16.9	16.4	15.8	28
30					17.3	17.1	17.2	17.0	16.8	16.3	15.9	15.4	14.9	14.2	30
32						15.5	15.5	15.4	15.2	14.8	14.5	14.0	13.5	13.0	32
34						14.0	14.1	13.9	13.8	13.5	13.3	12.8	12.3	11.8	34
36							12.8	12.7	12.5	12.3	12.2	11.7	11.3	10.8	36
38								11.5	11.4	11.2	11.1	10.8	10.4	9.9	38
40									10.4	10.2	10.1	9.9	9.5	9.2	40
42									9.4	9.2	9.2	9.0	8.8	8.4	42
44										8.4	8.4	8.1	7.9	7.6	44
46											7.6	7.3	7.1	6.8	46
48												6.6	6.4	6.1	48
50													5.7	5.4	50
55														3.9	55

TLT 10532960 M99999 Vorab1

### Maximum capacity in duty cycle operation with standard ropes

Line pull	kN	350
Rope diameter	mm	36
Minimum breaking load	kN	1186
Line pull - 1-rope duty cycle operation	t	30
Line pull - 2-rope duty cycle operation <sup>1)</sup>	t	49.2

- 1) Lifting a load exceeding the line pull of one winch is only allowed if it can be ensured that each individual winch is not overloaded. When working with a mechanical 2-rope grab the total load to be lifted is limited by the line pull of one winch. Rigging and ropes are part of the load.
- 2) Max. capacities in metric tons do not exceed 75% of tipping load. Crane standing on firm, horizontal ground.

Capacities in duty cycle operation are for reference only and are not programmed in the LMI system.

All loads and counterweight configurations are max. values and must not be exceeded.

Weight of additional equipment on boom (e.g. walkways, hose drums etc.) must be deducted to get the net capacity.



# Dragline equipment (main boom No. 2220.xx)

## 55.1 t counterweight

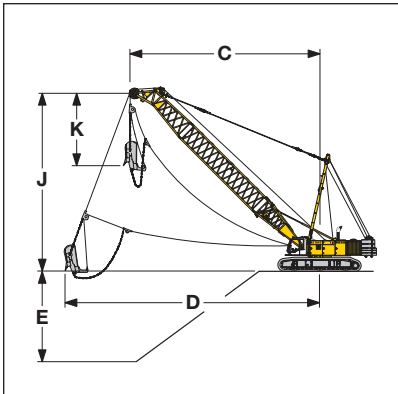

Capacities in metric tons for boom lengths (25.7 m - 55.1 m) counterweight 55.1 t

alpha	Boom length (m)																	
	25.7			31.7			37.4			43.4			49.1			55.1		
	C (m)	J (m)	t	C (m)	J (m)	t	C (m)	J (m)	t	C (m)	J (m)	t	C (m)	J (m)	t	C (m)	J (m)	t
45	21.1	19.7	29.1	25.3	24.0	22.3	29.3	28.0	17.8	33.6	32.3	14.0	37.6	36.3	11.3	41.9	40.5	8.8
40	22.5	18.0	26.5	27.1	21.9	20.1	31.5	25.6	15.9	36.1	29.4	12.5	40.4	33.1	9.9	45.0	36.9	7.5
35	23.8	16.2	24.5	28.7	19.6	18.5	33.4	22.9	14.5	38.3	26.3	11.2	43.0	29.6	8.8	47.9	33.1	6.4
30	24.9	14.3	22.9	30.1	17.3	17.2	35.1	20.1	13.4	40.3	23.1	10.2	45.2	26.0	7.9	50.4	29.0	5.6
25	25.9	12.2	21.7	31.3	14.8	16.1	36.5	17.2	12.5	41.9	19.7	9.5	47.1	22.1	7.1	52.5	24.6	4.9

TLT 10532960 M99999 Vorab1

Max. capacities in metric tons do not exceed 75% of tipping load.

Capacities in duty cycle operation are for reference only and are not programmed in the LMI system.

The size of the bucket has to be determined according to local conditions.

## Digging diagram

- C = Radius / dumping radius
- D = Max. digging radius = approx.  $C + 1/3$  to  $1/2 J - K$
- E = Digging depth = approx. 40 - 50% of C
- J = Height to centre rope pulley boom head
- K = Length of dragline bucket (according to manufacturer's specification)

# Clamshell equipment (main boom No. 2220.xx)

## 55.1 t counterweight

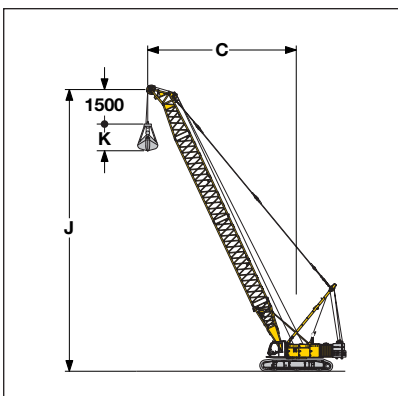

Capacities in metric tons for boom lengths (25.7 m - 55.1 m) counterweight 55.1 t

alpha	Boom length (m)																	
	25.7			31.7			37.4			43.4			49.1			55.1		
	C (m)	J (m)	t	C (m)	J (m)	t	C (m)	J (m)	t	C (m)	J (m)	t	C (m)	J (m)	t	C (m)	J (m)	t
65	14.0	25.2	45.6	16.5	30.6	36.0	18.9	35.8	29.7	21.5	41.2	24.6	23.9	46.4	20.8	26.4	51.8	17.5
60	15.9	24.1	38.1	18.9	29.3	29.8	21.8	34.2	24.4	24.8	39.4	20.0	27.6	44.3	16.7	30.6	49.5	13.8
55	17.8	22.8	32.7	21.2	27.7	25.5	24.5	32.4	20.6	27.9	37.3	16.7	31.2	41.9	13.8	34.6	46.9	11.2
50	19.5	21.3	28.8	23.3	25.9	22.2	27.0	30.3	17.9	30.9	34.9	14.3	34.5	39.3	11.7	38.4	43.9	9.3
45	21.1	19.7	25.9	25.3	24.0	19.8	29.3	28.0	15.8	33.6	32.3	12.5	37.6	36.3	10.1	41.9	40.5	7.9
40	22.5	18.0	23.6	27.1	21.9	17.9	31.5	25.6	14.2	36.1	29.4	11.1	40.4	33.1	8.8	45.0	36.9	6.7
35	23.8	16.2	21.8	28.7	19.6	16.4	33.4	22.9	12.9	38.3	26.3	10.0	43.0	29.6	7.8	47.9	33.1	5.8
30	24.9	14.3	20.3	30.1	17.3	15.3	35.1	20.1	11.9	40.3	23.1	9.1	45.2	26.0	7.0	50.4	29.0	5.1
25	25.9	12.2	19.2	31.3	14.8	14.3	36.5	17.2	11.1	41.9	19.7	8.4	47.1	22.1	6.4	52.5	24.6	4.6

TLT 10538305 M99999 Vorab1

Max. capacities in metric tons do not exceed 66.7% of tipping load.

Capacities in duty cycle operation are for reference only and are not programmed in the LMI system.

## Working diagram

- C = Radius / dumping radius
- J = Height of boom head sheave centre above ground level
- K = Length of clamshell (depending on type and capacity of bucket)

# Lift crane operation (main boom No. 2220.xx)

# 86° - 15°

## 75.1 t counterweight and 27 t carbody counterweight

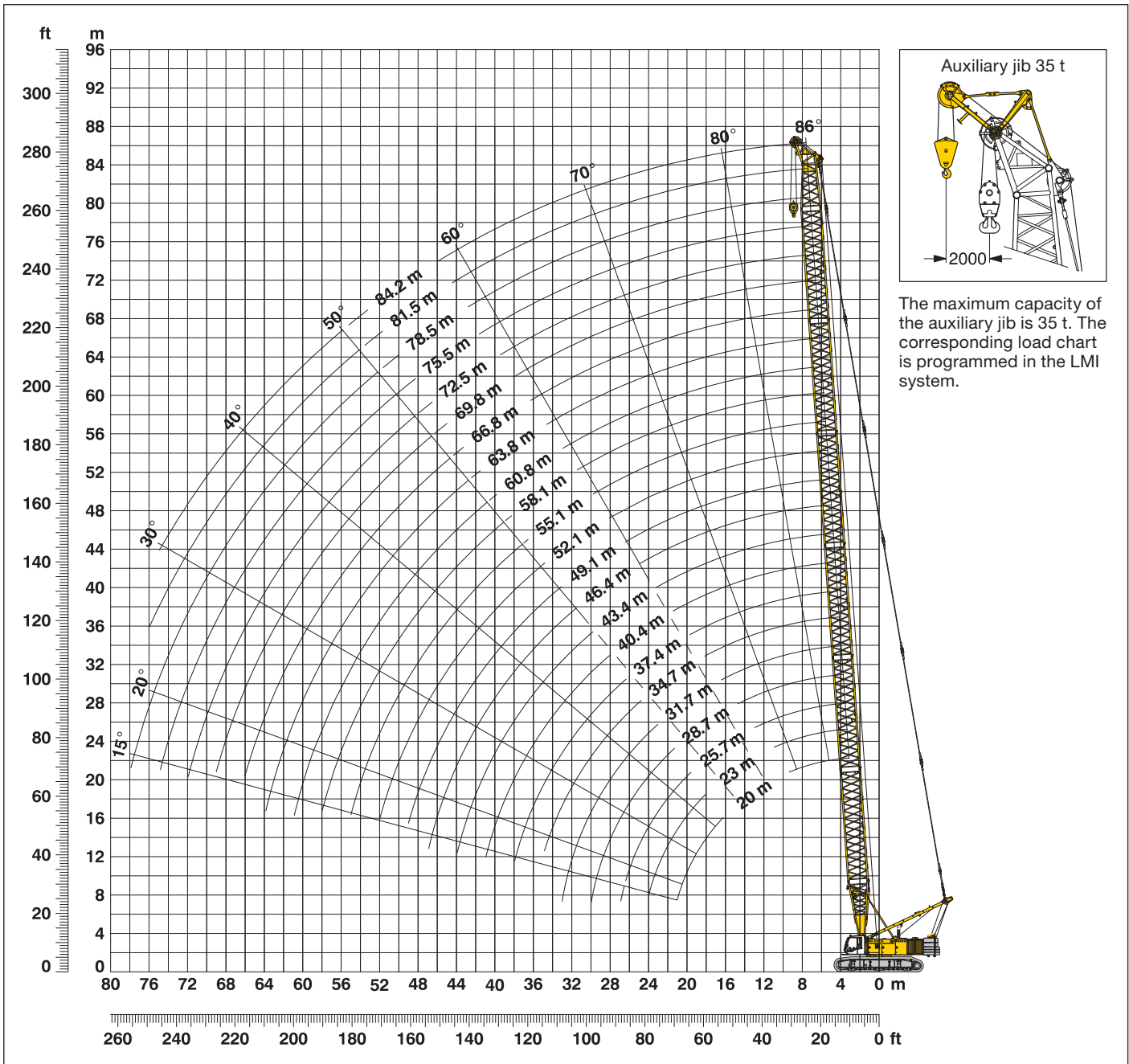

### Main boom configuration (Table 1)

Configuration for boom lengths (20 m - 84.2 m)

	Length	Amount of boom extensions																						
Boom foot	7.0 m	1	1	1	1	1	1	1	1	1	1	1	1	1	1	1	1	1	1	1	1			
Boom section	3.0 m		1		1		1		1		1		1		1		1		1		1			
Boom section	6.0 m	1	1		1	1	1		1	1		1	1		1	1	1		1	1	1			
Boom section	11.7 m			1	1	1	1	2	2	2	2	3	3	3	3	4	4	4	4	5	5	5	5	6
Boom head	7.0 m	1	1	1	1	1	1	1	1	1	1	1	1	1	1	1	1	1	1	1	1	1	1	
Boom length (m)		20	23	25.0	28.7	31.7	34.7	37.4	40.4	43.4	46.4	49.1	52.1	55.1	58.1	60.8	63.8	66.8	69.8	72.5	75.5*	78.5*	81.5*	84.2*

\*) Additional counterweight allows self-erection of boom up to 84.2 m.

# Load chart for lift crane operation (main boom No. 2220.xx)

## 55.1 t counterweight

Capacities in metric tons for boom lengths (20 m - 72.5 m) - with 350 kN winches

Radius (m)	Boom length (m)																		Radius (m)			
	20	23	25.7	28.7	31.7	34.7	37.4	40.4	43.4	46.4	49.1	52.1	55.1	58.1	60.8	63.8	66.8	69.8		72.5		
4.9	175.5																				4.9	
5	173.8																				5	
6	161.4	161.0	154.9																		6	
7	137.7	132.5	128.3	123.6	119.3	115.2															7	
8	116.2	112.3	109.2	105.7	102.4	99.2	96.6	93.8	91.0												8	
9	100.3	97.2	94.9	92.1	89.5	87.0	84.9	82.6	80.4	78.2	76.4	74.4	72.7								9	
10	88.0	85.6	83.8	81.5	79.4	77.2	75.6	73.6	71.8	69.9	68.4	66.7	65.1	63.4	62.1	59.5					10	
12	67.3	67.3	67.5	65.9	64.4	62.8	61.6	60.2	58.8	57.4	56.3	55.0	53.7	52.4	51.4	50.2	49.0	47.4	42.9		12	
14	54.1	54.0	54.2	54.1	53.8	52.6	51.7	50.5	49.4	48.3	47.4	46.4	45.3	44.3	43.5	42.5	41.5	40.5	39.2	14		
16	44.8	44.8	45.0	44.9	44.8	44.6	44.3	43.3	42.4	41.4	40.7	39.8	38.9	38.0	37.4	36.5	35.7	34.8	34.2	16		
18	38.0	38.0	38.2	38.1	38.0	37.7	37.8	37.5	36.9	36.0	35.5	34.6	33.9	33.1	32.5	31.7	31.0	30.2	29.7	18		
20	32.7	32.7	33.0	32.8	32.7	32.5	32.5	32.3	32.1	31.7	31.2	30.5	29.8	29.1	28.5	27.9	27.2	26.5	26.0	20		
22		28.5	28.8	28.7	28.6	28.4	28.4	28.1	28.0	27.7	27.6	27.0	26.4	25.7	25.3	24.6	24.0	23.4	22.9	22		
24		25.0	25.4	25.3	25.2	25.0	25.0	24.8	24.6	24.3	24.2	24.0	23.5	22.9	22.5	21.9	21.3	20.7	20.3	24		
26			22.5	22.5	22.4	22.2	22.2	22.0	21.8	21.5	21.4	21.2	21.0	20.5	20.1	19.6	19.0	18.4	18.0	26		
28				20.1	20.0	19.8	19.9	19.6	19.4	19.2	19.1	18.8	18.6	18.3	18.1	17.5	17.0	16.5	16.1	28		
30				17.9	18.0	17.8	17.8	17.6	17.4	17.2	17.1	16.8	16.6	16.3	16.2	15.8	15.3	14.7	14.4	30		
32					16.2	16.0	16.1	15.9	15.7	15.4	15.3	15.1	14.8	14.6	14.4	14.2	13.7	13.2	12.9	32		
34						14.5	14.6	14.3	14.2	13.9	13.8	13.6	13.3	13.0	12.9	12.6	12.3	11.8	11.5	34		
36							13.2	13.0	12.8	12.5	12.5	12.2	12.0	11.7	11.6	11.3	11.0	10.6	10.3	36		
38								11.9	11.8	11.6	11.3	11.3	11.0	10.8	10.5	10.4	10.1	9.8	9.5	9.2	38	
40									10.7	10.5	10.3	10.2	10.0	9.7	9.4	9.3	9.0	8.8	8.5	8.2	40	
42										9.5	9.3	9.3	9.0	8.8	8.5	8.3	8.1	7.8	7.5	7.3	42	
44										8.6	8.4	8.4	8.1	7.9	7.6	7.5	7.2	6.9	6.6	6.5	44	
46											7.6	7.6	7.3	7.1	6.8	6.7	6.4	6.1	5.8	5.7	46	
48												6.8	6.6	6.4	6.1	6.0	5.7	5.4	5.1	5.0	48	
50													5.9	5.7	5.4	5.3	5.0	4.8	4.5	4.3	50	
55														4.2	3.9	3.8	3.6	3.3	3.0	2.9	55	
60																2.6	2.3	2.1	1.8	1.7	60	
65																	1.0				65	

TLT 901017914 - M 00000

Above load chart is for reference only. For actual lift duty please refer to load chart in operator's cab or manual.

# Load chart for lift crane operation (main boom No. 2220.xx)

## 75.1 t counterweight and 27 t carbody counterweight

Capacities in metric tons for boom lengths (20 m - 84.2 m) - with 350 kN winches																				
Radius	Boom length (m)																		Radius	
	20	25.7	28.7	34.7	37.4	43.4	46.4	49.1	52.1	55.1	58.1	60.8	63.8	66.8	69.8	72.5	75.5	78.5*		84.2*
(m)	t	t	t	t	t	t	t	t	t	t	t	t	t	t	t	t	t	t	t	(m)
5	200.0																			5
6	192.7	197.1	194.4																	6
7	179.6	168.3	162.3	151.3	146.9															7
8	152.9	143.8	139.3	130.9	127.3	120.1	116.7	111.1												8
9	132.3	125.2	121.6	115.0	112.4	104.2	103.5	101.1	98.5	93.9	88.2									9
10	116.2	110.8	107.8	102.4	100.2	95.4	93.1	90.9	88.7	86.6	83.8	73.1	68.7	64.5						10
12	89.2	89.4	87.6	83.7	82.2	78.6	76.8	75.4	73.5	72.0	70.4	66.6	62.5	58.7	55.3	50.6	47.3	49.8	41.3	12
14	72.0	72.2	72.1	70.4	69.3	66.5	65.1	64.0	62.7	61.4	59.9	58.9	57.7	53.8	50.5	46.3	43.2	47.2	39.8	14
16	60.0	60.2	60.1	59.8	59.7	57.4	56.2	55.3	54.2	53.2	52.1	51.1	50.0	49.0	47.1	43.3	40.1	45.2	38.5	16
18	51.1	51.4	51.2	50.9	50.9	50.2	49.2	48.5	47.5	46.6	45.7	45.0	43.9	43.0	42.1	40.9	37.8	39.7	37.5	18
20	44.3	44.6	44.5	44.1	44.1	43.7	43.5	43.0	42.1	41.3	40.5	39.9	39.1	38.2	37.3	36.7	35.7	35.4	33.8	20
22		39.2	39.1	38.8	38.8	38.4	38.1	38.0	37.7	37.0	36.2	35.6	34.9	34.2	33.5	32.7	32.0	31.5	30.3	22
24		34.8	34.7	34.4	34.4	34.0	33.7	33.7	33.4	33.2	32.6	32.1	31.4	30.7	30.0	29.4	28.7	28.2	27.1	24
26		31.1	31.1	30.8	30.8	30.4	30.1	30.0	29.8	29.6	29.3	29.0	28.4	27.8	27.1	26.7	25.9	25.4	24.4	26
28			28.0	27.8	27.8	27.3	27.1	27.0	26.7	26.5	26.2	26.1	25.8	25.2	24.6	24.1	23.6	23.0	22.0	28
30			25.3	25.1	25.2	24.8	24.5	24.4	24.1	23.9	23.6	23.5	23.2	22.9	22.3	21.9	21.4	20.8	19.9	30
32				22.9	22.9	22.5	22.2	22.2	21.9	21.7	21.4	21.3	21.0	20.7	20.4	20.0	19.5	18.9	18.0	32
34				20.9	20.9	20.5	20.3	20.2	19.9	19.7	19.4	19.3	19.0	18.8	18.5	18.3	17.7	17.2	16.3	34
36					19.2	18.8	18.5	18.5	18.2	18.0	17.7	17.6	17.3	17.0	16.7	16.6	16.2	15.7	14.8	36
38					17.6	17.3	17.0	16.9	16.7	16.4	16.2	16.0	15.7	15.5	15.2	15.0	14.8	14.3	13.5	38
40						15.9	15.6	15.6	15.3	15.1	14.8	14.7	14.4	14.1	13.8	13.7	13.4	13.1	12.3	40
42						14.6	14.4	14.3	14.1	13.8	13.5	13.4	13.1	12.9	12.6	12.4	12.1	11.9	11.1	42
44						13.4	13.2	13.2	12.9	12.7	12.4	12.3	12.0	11.8	11.5	11.3	11.0	10.8	10.1	44
46							12.2	12.2	11.9	11.7	11.4	11.3	11.0	10.8	10.5	10.3	10.0	9.7	9.2	46
48								11.2	11.0	10.8	10.5	10.4	10.1	9.8	9.5	9.4	9.1	8.8	8.3	48
50									10.1	9.9	9.6	9.5	9.2	9.0	8.7	8.5	8.2	8.0	7.5	50
55										8.0	7.7	7.6	7.4	7.1	6.8	6.7	6.4	6.1	5.6	55
60												6.1	5.8	5.6	5.3	5.1	4.9	4.6	4.1	60
65														4.2	4.0	3.8	3.6	3.3	2.8	65
70																2.7	2.4	2.2	1.7	70
75																	1.4	1.2		75

TLT 901017914 - M 00000

\*) with mid-point suspension

Above load chart is for reference only. For actual lift duty please refer to load chart in operator's cab or manual.

# Working range - fixed jib (No. 1008.xx)

Main boom 86° - 30°

# 15° and 30°

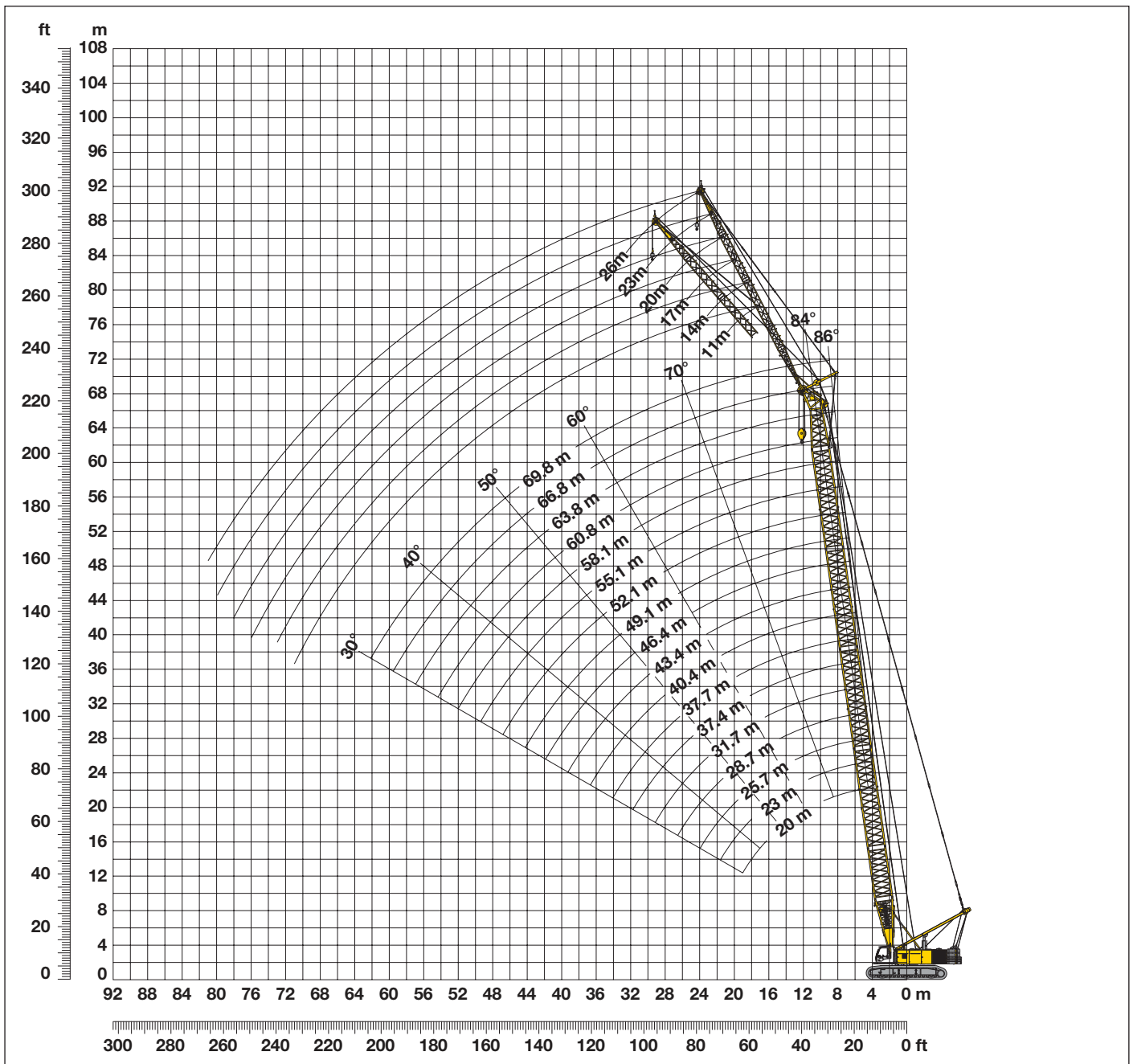

## Boom configuration for boom lengths (20 m - 69.5 m) - see table 1, page 10

### Fixed jib configuration for fixed jib lengths (11 m - 26 m)

	Length	Amount of fixed jib extensions					
Fixed jib foot	5.5 m	1	1	1	1	1	1
Fixed jib section	3.0 m		1		1		1
Fixed jib section	6.0 m			1	1	2	2
Fixed jib head	5.5 m	1	1	1	1	1	1
Fixed jib length (m)		11	14	17	20	23	26

# Load chart - fixed jib (No. 1008.xx)

Offset 15°

## Main boom 20 m

Radius	Fixed jib length (m)			
	11	14	20	26
(m)	t	t	t	t
7.8	45.0			
10	43.8	43.2		
12	41.2	39.2	25.2	
15	36.4	34.8	22.6	15.6
18	35.6	31.9	21.0	14.5
20	35.5	28.6	20.1	13.9
24	30.1	24.1	17.7	12.9
28	26.2	22.4	15.9	11.9
30	24.5	21.2	14.7	11.5
32		19.9	13.8	11.2
38			12.0	9.5
44				8.4

## Main boom 28.7 m

Radius	Fixed jib length (m)			
	11	14	20	26
(m)	t	t	t	t
8.4	44.8			
10	42.2	40.2		
13	36.5	34.9	24.2	
16	34.4	32.0	22.3	15.2
20	33.5	31.8	20.8	14.2
24	33.4	27.7	19.5	13.3
28	28.1	24.5	17.4	12.5
32	23.1	22.4	16.0	11.8
36	19.3	19.8	14.2	11.2
40		16.7	13.0	10.2
46			11.8	9.1
50				8.6

## Main boom 37.4 m

Radius	Fixed jib length (m)			
	11	14	20	26
(m)	t	t	t	t
9	41.9			
11	37.8	35.3		
14	33.5	31.7	23.4	
16	31.8	30.5	22.4	15.2
20	31.7	29.9	21.1	14.3
28	27.5	26.8	19.1	12.8
36	18.7	19.2	16.1	11.6
40	15.7	16.2	14.6	11.1
44	13.3	13.7	13.5	10.4
48		11.6	12.4	9.7
50			11.5	9.4
60				8.3

## Main boom 46.4 m

Radius	Fixed jib length (m)			
	11	14	20	26
(m)	t	t	t	t
9.6	23.0			
11	35.3	23.0		
14	31.9	29.1	23.1	
17	30.2	28.2	21.9	14.8
20	29.8	27.9	21.1	14.3
28	26.7	27.2	19.4	13.0
36	17.9	18.3	16.9	12.0
44	12.5	12.9	13.6	11.1
50	9.6	10.0	10.7	10.2
55		8.0	8.7	9.3
60			7.0	7.6
65				6.2

## Main boom 49.1 m

Radius	Fixed jib length (m)			
	11	14	20	26
(m)	t	t	t	t
9.8	23.0			
12	33.1	30.6		
14	31.3	28.4	21.3	
17	29.8	27.5	21.8	14.7
20	29.3	27.3	21.1	14.2
28	26.5	27.0	19.5	13.1
36	17.8	18.2	17.3	12.1
44	12.4	12.8	13.5	11.2
48	10.4	10.7	11.4	10.7
55	7.5	7.9	8.6	9.1
60			6.9	7.5
70				4.8

## Main boom 55.1 m

Radius	Fixed jib length (m)			
	11	14	20	26
(m)	t	t	t	t
10.2	23.0			
12	31.8	29.4		
15	29.4	26.5	22.2	
18	28.5	26.1	21.4	14.4
20	28.2	26.1	21.0	14.1
28	25.6	25.9	19.5	13.1
36	17.2	17.7	17.9	12.2
44	11.8	12.2	13.0	11.3
55	7.0	7.4	8.0	8.6
60	5.4	5.7	6.4	6.9
65			5.0	5.5
75				3.2

## Main boom 60.8 m

Radius	Fixed jib length (m)			
	11	14	20	26
(m)	t	t	t	t
10.6	23.0			
12	30.4	23.0		
15	27.6	25.6	21.5	
18	27.2	24.9	20.9	14.2
20	26.9	24.8	20.6	13.9
28	24.5	24.7	19.3	13.0
36	16.8	17.2	17.7	12.1
44	11.3	11.7	12.5	11.4
55	6.5	6.9	7.6	8.2
65	3.6	3.9	4.5	5.1
70			3.3	3.9
80				1.8

## Main boom 66.8 m

Radius	Fixed jib length (m)			
	11	14	20	26
(m)	t	t	t	t
11	23.0			
13	28.0	25.7		
16	25.9	24.1	20.1	
18	25.8	23.7	20.1	12.5
24	25.7	23.6	19.6	13.3
32	19.1	19.5	18.5	12.5
40	13.1	13.4	14.1	11.8
48	8.8	9.2	9.9	10.4
65	3.0	3.4	4.0	4.6
70	1.9	2.2	2.8	3.3
75			1.7	2.3
80				1.3

## Main boom 69.8 m

Radius	Fixed jib length (m)			
	11	14	17	20
(m)	t	t	t	t
11.2	23.0			
13	27.4	24.8		
15	25.8	23.8	21.7	
16	25.2	23.4	21.6	19.4
18	25.1	22.9	21.3	19.4
24	24.8	22.8	21.1	19.1
32	18.6	19.0	19.3	18.2
40	12.6	12.9	13.3	13.6
48	8.5	8.8	9.1	9.4
65	2.7	3.1	3.4	3.7
70	1.6	1.9	2.2	2.5
75			1.2	1.4

TLT 9510179 - M 00000

Capacities in metric tons with fixed jib (No. 1008.xx), 75.1 t counterweight + 27 t carbody counterweight. Above load chart is for reference only. For actual lift duty please refer to load chart in operator's cab or manual.

# Load chart - fixed jib (No. 1008.xx)

Offset 30°

## Main boom 20 m

Radius	Fixed jib length (m)			
	11	14	20	26
(m)	t	t	t	t
10.2	42.8			
13	35.8	27.7		
17	29.4	23.0	17.2	
22	24.3	20.6	14.2	11.3
24	23.0	19.3	13.2	10.6
26	23.0	18.1	12.5	10.0
28	22.6	17.1	11.8	9.4
30	21.9	16.4	11.3	9.0
32		15.9	10.8	8.5
38			10.0	7.5
42				7.1
44				7.0

## Main boom 28.7 m

Radius	Fixed jib length (m)			
	11	14	20	26
(m)	t	t	t	t
10.8	37.5			
13	34.1	28.6		
17	30.6	24.4	17.6	
22	27.3	22.3	15.0	11.6
26	24.5	20.2	13.3	10.4
30	23.0	18.3	12.2	9.5
34	21.3	16.8	11.3	8.7
38	17.8	16.0	10.6	8.1
40		15.7	10.3	7.8
44			10.0	7.4
46			9.8	7.2
50				7.0

## Main boom 37.4 m

Radius	Fixed jib length (m)			
	11	14	20	26
(m)	t	t	t	t
11.2	34.7			
14	31.2	27.8		
18	29.6	24.4	17.2	
22	28.8	22.5	15.5	11.8
26	26.1	21.5	13.9	10.7
30	24.0	19.5	12.8	9.8
34	20.9	18.0	11.8	9.1
38	17.5	16.8	11.1	8.4
42	14.7	15.2	10.5	7.9
46		12.8	10.1	7.5
50			9.9	7.2
55				7.0

## Main boom 46.4 m

Radius	Fixed jib length (m)			
	11	14	20	26
(m)	t	t	t	t
12	30.1			
14	27.8	25.6		
18	26.9	24.5	17.3	
22	26.9	23.3	16.2	12.0
30	24.6	21.5	13.5	10.3
38	16.7	17.2	11.9	9.0
42	13.9	14.4	11.3	8.5
46	11.7	12.1	10.8	8.1
50	9.7	10.2	10.4	7.7
55		8.1	9.0	7.3
60			7.2	7.1
65				6.3

## Main boom 49.1 m

Radius	Fixed jib length (m)			
	11	14	20	26
(m)	t	t	t	t
12.2	29.1			
15	26.5	24.6		
19	26.2	23.9	17.0	
24	26.2	22.8	15.5	11.5
30	24.4	22.0	13.7	10.4
38	16.6	17.1	12.1	9.1
42	13.8	14.3	11.5	8.6
46	11.6	12.0	11.0	8.2
50	9.7	10.1	10.6	7.8
55	7.6	8.0	8.9	7.4
65			5.5	6.3
70				4.9

## Main boom 55.1 m

Radius	Fixed jib length (m)			
	11	14	20	26
(m)	t	t	t	t
12.6	27.3			
15	25.7	23.2		
19	25.1	23.0	17.0	
24	25.1	23.0	15.8	11.5
30	23.9	22.1	14.1	10.5
38	16.1	16.7	12.5	9.3
42	13.3	13.8	11.9	8.9
46	11.1	11.5	11.3	8.4
50	9.2	9.6	10.5	8.0
60	5.5	5.9	6.7	7.3
70			3.8	4.5
75				3.3

## Main boom 60.8 m

Radius	Fixed jib length (m)			
	11	14	20	26
(m)	t	t	t	t
13	25.5			
15	24.5	21.8		
19	23.7	21.7	17.1	
24	23.7	21.7	16.0	11.5
30	23.0	21.6	14.5	10.6
38	15.7	16.3	12.8	9.5
46	10.6	11.1	11.7	8.6
50	8.8	9.2	10.1	8.2
60	5.1	5.5	6.3	7.0
65	3.7	4.0	4.8	5.5
75			2.3	3.0
80				1.9

## Main boom 66.8 m

Radius	Fixed jib length (m)			
	11	14	20	26
(m)	t	t	t	t
13.4	23.0			
16	23.1	20.6		
20	22.6	20.6	16.9	
24	22.6	20.6	15.9	11.4
30	21.9	20.4	14.6	10.7
38	15.0	15.5	13.1	9.7
46	10.1	10.6	11.6	8.8
50	8.2	8.7	9.6	8.5
60	4.6	5.0	5.8	6.6
70	1.9	2.3	3.0	3.7
75			1.9	2.6
80				1.5

## Main boom 69.8 m

Radius	Fixed jib length (m)			
	11	14	17	20
(m)	t	t	t	t
13.6	22.9			
16	22.4	19.9		
18	22.0	19.9	18.2	
20	21.9	19.9	18.2	16.6
22	21.9	19.9	18.2	16.2
30	21.4	19.9	17.9	14.6
38	14.5	15.0	15.5	13.2
46	9.8	10.3	10.7	11.1
50	7.9	8.4	8.9	9.3
60	4.3	4.7	5.2	5.6
70	1.7	2.0	2.4	2.8
75			1.3	1.6

TLT 9510179 - M 0000

Capacities in metric tons with fixed jib (No. 1008.xx), 75.1 t counterweight + 27 t carbody counterweight. Above load chart is for reference only. For actual lift duty please refer to load chart in operator's cab or manual.