

MAHINDRA

T R A C T O R S

OPERATOR'S MANUAL & INSTALLATION INSTRUCTION 'ML114' Series

Click here to go on

INDEX

Main Menu



Cultivate
Your
DreamsSM

**Includes: Operator's Manual and Installation
Instructions**

Mahindra USA

Model ML114

Front End Loader



Rev. March 2005

1503-1059

WARRANTY CONDITIONS

Warranty Coverage:

Mahindra USA, Inc., herein referred to as Mahindra, undertakes to replace or repair any part of a Mahindra loader where damage has been proven to be caused by defects in material or workmanship.

This Warranty is valid for a period of 1 year for all hydraulic components and attachments and for a period of 2 years for all other loader components from the date of the original retail sale. Parts replaced or repaired under the terms of this Warranty are guaranteed only until the original warranty expires.

It is further understood and agreed that the defect should be immediately reported to the Selling Dealer. The Selling Dealer will generally perform Warranty repairs or replacements and the Purchaser shall deliver the Mahindra Loader to the Dealer's place of business for repair. In the event Purchaser is located more than 75 miles from the Selling Dealer, any Mahindra Dealer authorized to sell and service Mahindra Products may perform the repair at its dealership.

The obligation of Mahindra to the Purchaser under this Warranty is limited to the repair or replacement of defective parts by an authorized Mahindra dealer. Repair or replacement in accordance with this Warranty shall constitute fulfillment of all liabilities of Mahindra and the Selling Dealer in respect to Mahindra Loaders.

There are no warranties beyond those which expressly appear herein. Any implied warranty of merchantability or fitness for a particular purpose is specifically excluded here from.

Warranty Provisions:

Mahindra's liability under this Warranty is subject to the observance by the Purchaser of the following provisions:

- The purchaser shall at all times in the operation of any Mahindra Product, use those brands and grades of lubricating oils, lubricants or fuel and spare parts officially approved by Mahindra.
- The Mahindra Loaders shall have been used in accordance with the procedures specified in the Operator's Manual. This Warranty does not extend to damage resulting from misapplication, abuse, misuse, failure to perform maintenance, negligence, fire, accidents or changes or faulty mounting carried out by the Purchaser. When making a Warranty exchange of parts, the Purchaser shall compensate Mahindra for the time that the parts have been used if they have been exposed to extreme wear.
- Compensation is not paid for physical harm, deadlock, resulting damages, or other losses.
- To obtain warranty service, the Purchaser must (1) report the product defect to an authorized Mahindra dealer and request repair within the applicable warranty term and (2) present evidence of purchase or date of original use.
- The Warranty shall be void if the Mahindra Loader has been altered or repaired outside of a Mahindra dealership in a manner, which, in the sole judgment of Mahindra, affects its performance, stability, or reliability.
- The customer shall be responsible for transportation expenses for the Mahindra Loader to the dealership or travel of dealer personnel to customer location for Warranty repair. The customer shall also pay any premium for overtime labor requested by the customer.
- Temporary repairs or additional costs due to the work being performed after normal working hours will not be compensated.
- The above warranty is in lieu of all other warranties on Mahindra's behalf and neither party assumes any other liability in connection with Mahindra's Products.
- Any dispute arising between Mahindra and the Purchaser concerning the liability of Mahindra under this warranty shall be subject to the laws of the State of Texas.

Right To Make Design and Product Changes:

Mahindra reserves the right to make changes in the design and other changes in its Mahindra Products at any time without incurring any obligation with respect to any product previously ordered, sold or shipped.

CONGRATULATIONS

You are now the proud owner of a MAHINDRA ML114 Loader. This loader is a product of quality engineering and manufacturing. It is made of fine materials and under a rigid quality control system. It will give you long, satisfactory service. To obtain the best use of your loader, please read this manual carefully. It will help you become familiar with the operation of the loader and contains many helpful hints about loader maintenance. The immediate use of new techniques in the manufacture of products may cause some small parts of this manual to be outdated. Mahindra dealers will have the most up-to-date information. Please do not hesitate to consult with them.

SAFETY ALERTS

This symbol, the industry's "Safety Alert Symbol," is used throughout this manual and on labels to warn of the possibility of personal injury. When you see this symbol, carefully read the messages and be alert to the possibility of injury or death. It is essential you read these instructions and safety regulations before you attempt to assemble or use this unit.

**DANGER:**

Indicates an imminently hazardous situation which, if not avoided, will result in death or serious injury.

**WARNING:**

Indicates a potentially hazardous situation which, if not avoided, could result in death or serious injury.

**CAUTION:**

Indicates a potentially hazardous situation which, if not avoided, may result in minor or moderate injury.

IMPORTANT:

Indicates that equipment or property damage could result if instructions are not followed.

NOTE:

Gives helpful information.



SAFETY

Most tractor and/or loader equipment accidents can be avoided by following simple safety precautions. The safety information given in this manual does not replace safety codes, insurance requirements, federal, state, and local laws. Make sure your machine has the correct equipment required by your local laws and regulations. Understand that your safety and the safety of other persons are measured by how you service and operate this loader.

Know the position and operations of all controls before you try to operate. Make sure you check all controls in a safe area before starting.

Read this manual completely and thoroughly and make sure you understand all controls. All equipment has a limit. Make sure you are aware of the stability and load characteristics of this loader before you begin operation.



This safety alert symbol indicates important safety messages in this manual. When you see this symbol, carefully read the message that follows and be alert to the possibility of personal injury or death.



SAFETY PRECAUTIONS



READ MANUALS AND DECALS

1. Read and understand both the tractor and the loader Operator Manuals and all decals before using the loader.
2. Lack of knowledge can lead to accidents.
3. It is the loader owner's responsibility to make sure anyone operating the loader reads and understands this manual first before operating the machine.
4. Follow all safety, operating, and service instructions.
5. Replace damaged or illegible safety labels. See following pages for required labels.

ROPS AND SEAT BELT

6. Equip your tractor with an approved rollover-protective structure (ROPS) or ROPS Cab and seat belt for your protection.
7. ROPS (Roll-Over Protective Structures) and seat belt equipped tractors are recommended for operator use in all loader operations.
8. Operator should wear safety hard hat, safety glasses, safety shoes, and other PPE. Avoid wearing loose clothing or jewelry that may catch in moving parts.
9. Use seat belt as specified by tractor/ROPS manufacturer.

YOURSELF

10. Do not stand, walk, or work under a raised loader bucket or attachment unless it is securely blocked and held in position.
11. Operate controls only when properly seated in the operator's seat.
12. Only one person, the operator, should be on the machine when it is in operation.
13. Accidental movement of valve handle/handles or leak in the hydraulic system could cause the loader to drop, or attachment to dump, causing severe injury.

OTHERS

14. Do not allow anyone in loader work area, under raised loader, or to reach through the loader boom when the bucket or attachment is raised.
15. A frequent cause of personal injury or death is persons falling off and being run over. Inadvertent movement of the loader or attachment could result in serious injury or death.
16. Do not permit others to ride on your tractor, loader, bucket, or any attachment.
17. Do not lift or carry anyone on buckets, forks, probes, or any other portion of the loader or loader attachments.
18. Do not allow children or unqualified persons to operate equipment.



SAFETY PRECAUTIONS



PREPERATION

19. Move the wheels to the tractor manufacturer's widest recommended settings to increase stability.
20. For better stability, always use a tractor equipped with a wide front axle, never use a tractor equipped with a tricycle type front axle.
21. Add rear ballast or rear weight to the tractor to compensate for the load and increase stability.
22. Add recommended rear tire liquid weight or rear wheel weights for increased stability.
23. Do not modify, alter, or permit anyone else to modify or alter the loader, any of its components, or any loader function without first consulting a Mahindra dealer.
24. Assemble, remove, and reinstall the loader only as directed in this manual. Failure to do this could result in serious personal injury or death.
25. The loader may shift during shipping and handling, making it unstable on the pallet. Support loader with an overhead hoist or other suitable means prior to removing bands or attaching straps securing loader to pallet. Failure to do so could result in accidental tip-over of the loader that could cause serious injury to you and/or bystanders.

BEFORE OPERATION

26. Before starting the engine of your tractor, make sure all operating controls are in park lock or neutral position.
27. Be certain lights and safety markings, as provided by the tractor manufacturer, are clean and operating when transporting the tractor/loader on public roads. Be certain that the Slow Moving Vehicle (SMV) emblem is visible. Check with local law enforcement for specific requirements.

OPERATION

28. Add wheel ballast and/or rear weight to counterbalance tractor/loader for stability at maximum loader capacity.
29. Additional counterweight requirements will vary with loader attachments and equipment application.
30. Move and turn the tractor at low speeds.
31. Carry loader boom at a low position during normal operation.
32. Never travel at high speeds with bucket loaded.
33. Use caution when operating the loader with a raised bucket or attachment.
34. Avoid driving over loose fill, rocks, holes, or anything that may be dangerous for loader operation or movement.
35. Allow for the loader length when making turns.
36. Use caution when handling loose or unstable loads.
37. Gradually stop the loader boom when lowering or lifting loads.
38. When using remote hydraulic tractor valves on some tractors, the loader lift and dump cylinders will continue moving unless the valve handle/handles are manually returned to neutral, or until relief pressure is reached at the ends of piston strokes. Observe the bucket movement and maintain control with valve handle/handles.
39. Travel speed should be such that complete control and machine stability is maintained at all times. Where possible, avoid operating near ditches, embankments, and holes. Reduce speed when turning, crossing slopes, and on rough, slick or muddy surfaces.
40. A loader attachment should be transported in a low position at slow ground speeds. Make turns slowly and use the tractor brakes cautiously. A loaded attachment in the raised position alters the center of gravity location of the machine and increases the possibility of mishaps.
41. Be careful during loading, transporting, and stacking to minimize rolling bales and tractor tip over.
42. Do not use buckets, forks, or other attachments without bale retaining devices.
43. Operate the tractor and loader such that complete control and machine stability is maintained at all times.
44. When using a loader, be alert of bucket or attachment position at all times. Loader in raised position with bucket or attachment rolled back can dump material onto tractor causing damage or injury to tractor and/or operator.

LARGE HEAVY OBJECTS

45. Never use loader for handling large heavy objects, such as large round or rectangular bales, logs, and oil drums unless loader is equipped with attachment that is designed to handle such objects.
46. Handling large heavy objects can be extremely dangerous due to danger of rolling the tractor over.
47. Handling large heavy objects can be extremely dangerous due to danger of upending the tractor.
48. Handling large heavy objects can be extremely dangerous due to danger of the object rolling or sliding down the loader boom onto the operator.





SAFETY PRECAUTIONS



49. If you must handle large heavy objects, protect yourself by using caution, moving slowly, and avoiding bumps and rough ground.
50. If you must handle large heavy objects, protect yourself by never lifting load higher than necessary to clear the ground.
51. If you must handle large heavy objects, protect yourself by adding rear ballast to the tractor to compensate for weight of load.
52. If you must handle large heavy objects, protect yourself by never lifting large heavy objects that may roll or fall on the operator.
53. Never lift any load from any point of the loader with a chain, rope, or cable unless loader is equipped with a Factory approved attachment that was designed and built for this type of lifting. Always follow lifting instructions included with these attachments.
54. Use only Factory bale probe or bale retaining device handler attachment when handling round bales.
55. Do not handle large square bales without a retaining device handler attachment.
56. Do not use buckets, forks, or other attachments without bale retaining devices.
57. Do not use loader for handling large, heavy objects such as logs, tanks, etc.

SLOPES

58. Stay off of slopes too steep for safe operation.
59. Shift down before you start up or down a hill with a heavy load. Avoid "free wheeling."
60. Use extreme caution when operating on a slope.
61. Always operate up and down the slope, never across the slope.

ELECTRICAL

62. Avoid contact with overhead wires, power lines, and obstacles when loader bucket or attachment is raised.
63. Electrocution from power lines can occur with or without contact.
64. Check for underground utilities before digging below grade level.
65. Contact with overhead power lines can cause severe electrical burns or death from electrocution. Make sure there is enough clearance between raised equipment and overhead power lines.

HYDRAULIC

66. Do not tamper with the relief valve setting. This will void warranty and could cause damage to loader and/or tractor.
67. Escaping hydraulic fluid under pressure can have sufficient force to penetrate the skin, causing serious personal injury. Do not use HANDS to search for suspected leaks. If injured by escaping fluid, obtain medical treatment immediately.
68. Visually check for hydraulic leaks and broken, missing, or malfunctioning parts. Never use your hand to check for suspected leaks under pressure. Use a piece of cardboard or wood for this purpose. Escaping hydraulic fluid or diesel fuel leaking under pressure can have sufficient force to penetrate the skin and cause serious infection or other personal injury. If injured by leaking fluid, seek medical attention immediately.
69. To prevent personal injury, relieve all pressure before disconnecting fluid lines.
70. Before applying hydraulic pressure, make sure all hydraulic connections are tight and components are in good condition.
71. Be sure to purge all the air from the hydraulic system before attempting to raise or lower this machine.
72. When using remote hydraulic tractor valves on some tractors, the loader lift and dump cylinders will continue moving unless the valve handle/handles are manually returned to neutral, or until relief pressure is reached at the ends of piston strokes. Observe the bucket or attachment movement and maintain control with valve handle/handles.
73. Raised loader or boom can fall due to hydraulic system failure.
74. To avoid serious injury or death: Block up or securely support loader and boom before working underneath.
75. To avoid serious injury or death: Purge all air from hydraulic system before attempting to raise or lower loader or boom.
76. To avoid serious injury or death: Stand clear if lowering or raising loader or boom.
77. Do not use hand or skin to check for hydraulic leaks. Use cardboard or wood. Wear eye protection.
78. High pressure oil leaks can penetrate skin causing serious injury and gangrene. Consult a physician immediately.
79. Lower the loader or boom and release hydraulic pressure before loosening fittings.





SAFETY PRECAUTIONS



AFTER OPERATION

80. Before leaving the tractor seat, lower attachment or loader boom to ground, stop engine, lock parking brakes, put all controls in neutral, relieve hydraulic pressure, and remove key before leaving operator's seat.
81. Before disconnecting hydraulic lines, relieve all hydraulic pressure.
82. Make sure all parked loaders on stands are on a hard level surface with all safety devices engaged to prevent loader from falling and being damaged or injuring someone.
83. Always park loader with bucket attached to loader.
84. When a front loader is mounted on the tractor, enter and exit the operator's seat only from left side of the tractor.
85. Always park loader with a Factory attachment attached to the loader.
86. Special care should be taken to park or store attachments with points or sharp edges in a safe manner.
87. Make sure all parked loaders are on a hard level surface. Engage all safety devices to prevent loader from falling and being damaged or injuring someone. Do not repair loader if it is not mounted on the tractor. Loss of hydraulic fluid or removal of parts could cause loader to collapse resulting in injury.

REPAIR

88. Visually check for hydraulic leaks and broken, missing, or malfunctioning parts.
Make necessary repairs before operation.
89. To keep mounting kit hardware from loosening during loader operation, hardware must be torqued to specifications noted in operator manual.
90. Always wear safety goggles when servicing or repairing the machine.
91. When servicing or replacing pins in cylinder ends, bucket, etc., always use a brass drift and hammer. Failure to do so could result in injury from flying metal fragments.
92. Never tow from any point of the loader with a chain, rope, or cable. Doing so could cause a roll over or serious damage to the loader.





DANGER, WARNING, AND CAUTION DECAL SAFETY MESSAGES



0595-3000 WARNING DECAL

1. Add recommended rear wheel ballast and/or rear counter-weight for stability.
2. Move wheels to widest recommended setting to increase stability.
3. Move and turn tractor at low speeds.
4. In transport carry the load low.
5. Lower loader to the ground when parked.
6. Before servicing or adjusting equipment:
 - * lower loader to the ground.
 - * shut off engine.
7. Relieve hydraulic pressure before disconnecting oil lines.
8. Observe safety recommendations in Loader Operations Manual.

0595-3001 WARNING DECAL

Crushing Hazard

9. Stay away from under lift arms and bucket!
10. Do not stand or work under a raised loader.
11. Support bucket and lift arms before working under loader.
12. Lower loader to the ground before leaving seat.

0595-3002 DANGER DECAL

13. Keep machine clear of overhead power lines to avoid death or serious injury.

0595-3003 WARNING DECAL

14. To prevent rollback onto operator use special loader attachments for handling large objects such as stumps and large round bales.
15. Transport load as low as possible to avoid overturning.

0595-3004 WARNING DECAL

16. Read the operator's manual for complete operating instructions and safety information before operating the loader.
17. Be certain anyone operating the loader is aware of safe operating practices and potential hazards.
18. Operate the loader from the operator's seat only.
19. Do not lift or carry anyone on loader or work from bucket or attachment.
20. Do not walk or work under raised loader or bucket or attachment unless it is securely supported.
21. Avoid loose fill, rocks, and holes; they can be dangerous for loader operation or, movement.
22. Use extra caution when working on inclines.
23. Avoid overhead powerlines or obstacles when loader is raised.





DANGER, WARNING, AND CAUTION DECAL SAFETY MESSAGES



0595-2190 CAUTION DECAL

24. To prevent bodily injury and loader instability when detaching loader, equip loader with a material bucket.

0595-3050 DANGER DECAL

To avoid serious injury or death:

25. Unload only on a level surface.

26. Keep bystanders clear of work area when loading and unloading bales.

0595-3051 WARNING DECAL

27. Do not operate without confirmation that coupler pins are fully engaged.

28. Loader attachment can fall off if not properly attached.

To avoid serious injury or death:

29. Only use loader manufacturer approved attachments.

30. Read all operators manuals and decals before operating. Follow all safety operating and service instructions. Contact dealer for replacement parts.

0595-3052 WARNING DECAL

To avoid serious injury or death:

31. Do not use pallet fork attachment to lift large objects, round bales, or items that may roll or slide down loader arms onto the operator.

32. Never operate pallet fork without attaching plate guard.

33. Keep loads below pallet forks attaching plate guard heights.

34. Always transport loads with pallet forks low and level to ground.

35. Always keep pallet forks level when raising loads.

36. Avoid raising loads to full heights with pallet forks rolled back.

37. ROPS (Roll-Over Protective Structures) and seat belt equipped tractors are recommended for operator use in all pallet fork operations.

38. Do not lift or carry anyone on buckets, forks, probes, or any other portion of the loader or loader attachments.

39. Do not allow riders on tractor, loader, or forks.

40. Avoid contact with electrical power lines by loader or attachments.

0595-3053 WARNING DECAL

41. Maximum load limit on combined pair of forks is 5700 pounds.

0595-3054 CAUTION DECAL

To avoid serious injury or death:

42. Read operators manual and decals before operating.

43. Follow all safety operating, and service instructions. Contact dealer for replacement.

44. Be careful during loading transporting, and stacking to minimize rolling bales and tractor tip over. ROPS (Roll-Over Protective Structures) and seat belt equipped tractors are recommended for operator use in all bale probe operations.

45. Do not allow riders on tractor loader or bale probe.

46. Avoid loading/unloading bales on sloping or uneven surfaces.

47. Avoid transporting with bales raised high. Keep bales tilted back and low to the surface while moving.

48. Approach, penetrate, and transport bales at low speeds. Reduce speeds on curves, hills rough ground, or when turning.

49. Do not lift anything with bale probe except round bales.

50. Never raise round bale to full height with bale probe rolled back.

51. Park and store bale probe points pointed against bale, building, or other stable object.



SAFETY DECALS



WARNING

1. Add recommended rear wheel ballast and/or rear counterweight for stability.
2. Move wheels to widest recommended setting to increase stability.
3. Move and turn tractor at low speeds.
4. In transport carry the load low.
5. Lower loader to the ground when parked.
6. Before servicing or adjusting equipment;
 - * lower loader to the ground.
 - * shut off engine.
7. Relieve hydraulic pressure before disconnecting oil lines.
8. Observe safety recommendations in Loader Operations Manual.

0595-3000

WARNING

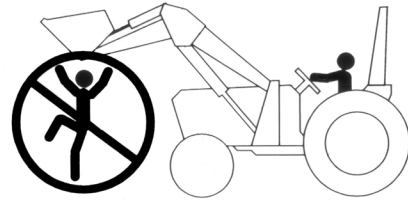

Crushing Hazard

Stay away from under lift arms and bucket!

1. Do not stand or work under a raised loader.
2. Support bucket and lift arms before working under loader.
3. Lower loader to the ground before leaving seat.

0595-3001

DANGER

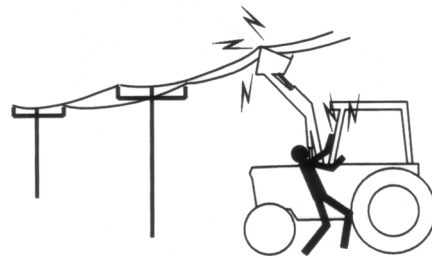

Keep machine clear of overhead power lines to avoid death or serious injury.

0595-3002



SAFETY DECALS



! WARNING



To prevent rollback onto operator
- use special loader attachments
for handling large objects such as
stumps and large round bales.

Transport load as low as possible
to avoid overturning.

0595-3003

! WARNING

1. Read the operator's manual for complete operating instructions and safety information before operating the loader.
2. Be certain anyone operating the loader is aware of safe operating practices and potential hazards.
3. Operate the loader from the operator's seat only.
4. Do not lift or carry anyone on loader or work from bucket or attachment.
5. Do not walk or work under raised loader or bucket or attachment unless it is securely supported.
6. Avoid loose fill, rocks and holes; they can be dangerous for loader operation or movement.
7. Use extra caution when working on inclines.
8. Avoid overhead powerlines or obstacles when loader is raised.

0595-3004

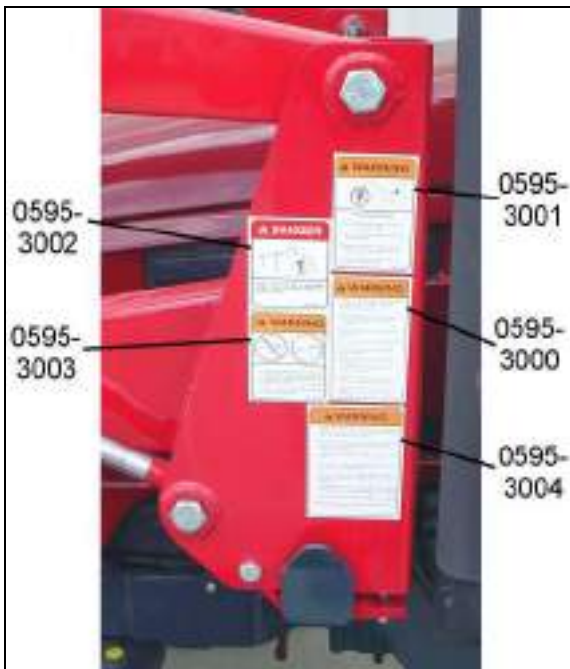

Safety Decal Locations

Important: Safety decals 0595-3000, 0595-3001, 0595-3002, 0595-3003, and 0595-3004 are located on the loader LH bearing box and are visible as you mount the tractor.

Care of Safety Decals

1. Keep safety decals clean and free of obstructing material.
2. Clean safety decals with soap and water and dry with a soft cloth.
3. Replace damaged or missing safety decals with new decals from your Mahindra Dealer.
4. If a component with a safety decal(s) affixed is replaced with a new part, make sure new safety decal(s) are attached in the same location(s) as the replaced components.
5. Mount new safety decals by applying on a clean dry surface and pressing air bubbles to outside edges.

TABLE OF CONTENTS

1. Specifications	14	11. Bale Probe – Pin On Or Skid Steer	43
1.1. Attachment Specifications.....	14	11.1. Bale Probe	44
2. Introduction	15	11.2. Assembly Instructions	44
3. Installation Instructions	16	11.3. Installation Instructions To Skid Steer Tool Carrier.....	44
3.1. Tractor Preparation	16	11.4. Installation Instructions To Pin On Quick Attach	44
3.2. Mounting Kit Installation.....	17	11.5. Installation Instructions Direct To Loader	44
3.3. Hydraulic Installation.....	21	11.6. Operating Instructions.....	44
3.4. Loader Installation.....	26	12. Pallet Fork – Pin On Or Skid Steer	45
3.5. Connect Hydraulics.....	26	12.1. Skid Steer Pallet Fork.....	45
3.6. Bucket Level Indicator.....	27	12.2. Assembly Instructions.....	46
4. Pre-Operation Instructions	28	12.3. Installation Instructions To Skid Steer Tool Carrier.....	46
4.1. Hydraulic Fluid	28	12.4. Installation Instructions To Pin On Quick Attach	46
4.2. Initial Loader Operation.....	28	12.5. Installation Instructions Direct To Loader	46
4.3. External Loader Valve	28	12.6. Operating Instructions.....	46
4.4. Loader Mounted Valve Equipped With Single Handle Control.....	28	12.7. Loader Parking Instructions	46
4.5. Neutral Position.....	29	13. Optional Pin On Quick Attach System	47
4.6. Float Position	29	13.1. Recommended Loader Factory Approved Attachments.....	47
4.7. Regenerative Dumping Position	29	13.2. Pin On Quick Attach	47
4.8. Initial Loader Operation.....	29	14. Installing Bucket Or Attachment To Pin On Quick Attach	48
4.9. Removing Air From Hydraulic System	29	14.1. Recommended Loader Factory Approved Attachments.....	48
5. Daily Maintenance & Lubrication	30	14.2. Keep These Areas Clean.....	48
5.1. Daily Checks	30	14.3. Operating Instructions.....	48
5.2. Loader Lubrication	30	15. Removing Bucket Or Attachment From Pin On Quick Attach	50
6. Operating Instructions	32	15.1. Operating Instructions.....	50
6.1. Filling The Bucket	32	16. Optional Skid Steer Tool Carrier System	51
6.2. Lifting The Load	32	16.1. Recommended Loader Factory Approved Attachments.....	51
6.3. Carrying The Load	32	16.2. Non-Loader Factory Attachments.....	51
6.4. Dumping The Bucket	33	16.3. Skid Steer Tool Carrier System Service & Lubrication	52
6.5. Lowering The Bucket	33	17. Installation & Operation Of Skid Steer Tool Carrier System	53
6.6. Operating With Float Control	33	17.1. Installation Instructions	53
6.7. Loading From A Bank	33	17.2. Skid Steer Tool Carrier Handles In Disengaged Position.....	53
6.8. Peeling And Scraping	34	17.3. Skid Steer Tool Carrier Handles In Engaged Position	53
6.9. Loading Low Trucks Or Spreaders From A Pile	34	18. Installing Bucket Or Attachment To Skid Steer Tool Carrier	54
6.10. Backfilling.....	34	18.1. Operating Instructions.....	54
6.11. Handling Large Heavy Objects	35		
6.12. Back Grading	35		
7. Dismounting The Loader	36		
8. Mounting The Loader	39		
9. Optional Grill Guard	41		
9.1. Installation Instructions	41		
10. Bucket– Pin On Or Skid Steer	42		
10.1. Installation Instructions To Skid Steer Tool Carrier.....	42		
10.2. Installation Instructions To Pin On Quick Attach.....	42		
10.3. Installation Instructions Direct To Loader	42		

19. Removing Bucket Or Attachment From Skid
Steer Tool Carrier.....57
19.1. Operating Instructions.....57

20. Trouble Shooting Procedures..... 58
21. Torque Chart..... 62

NOTES:



1. SPECIFICATIONS

**Model ML114
Front End Loader**

**For Use With
Model 4510
Tractor**

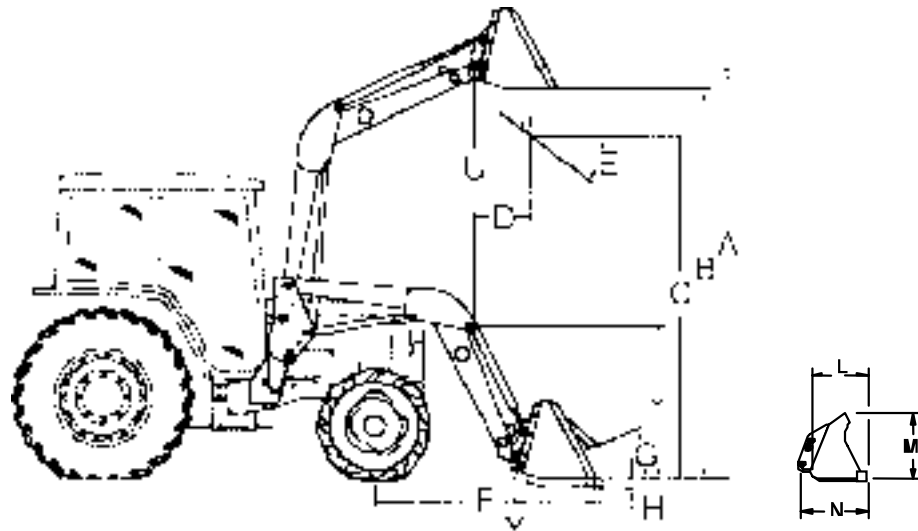

SPECIFICATIONS OF LOADER:	ML114
A. Maximum Lift Height to Pivot Pin	9' 3" (111")
B. Maximum Lift Height under Level Bucket	8' 9-1/8" (105-1/8")
C. Clearance with Bucket Fully Dumped	7' 5-3/4" (89-3/4")
D. Reach at Maximum Lift Height (to Grill)	2' 7-7/8" (31-7/8")
E. Maximum Dump Angle	58 degrees
F. Reach With Bucket on Ground	6' 3/4" (72-3/4")
G. Maximum Rollback Angle	19 degrees
H. Digging Depth	5.6"
J. Overall Height in Carry Position	4' 11-3/4" (59-3/4")
L. Bucket Depth	19.5"
M. Bucket Height	24.9"
N. Loader Bucket Pin to Front Cutting Edge	24.3"
U. Lift Capacity to Maximum Height at Pivot Pin	1,972 lb.
Y. Breakout Force at Ground Line at Pivot Pin	3,343 lb.

	1500 RPM	2000 RPM	2700(Full) RPM
Raising Time Ground Line to Maximum Lift Height	7.8 sec.	5.7 sec.	4.4 sec.
Lowering Time Maximum Lift Height to Ground Line	4.4 sec.	3.5 sec.	2.6 sec.
Dumping Time Full Rollback to Full Dump w/Regen	2.9 sec.	2.8 sec.	2.5 sec.
Rollback Time Full Dump to Full Rollback	3.9 sec.	2.9 sec.	2.6 sec.

Lift Cylinder Dia.	2"
Tilt Cylinder Dia.	2"
Relief Valve Setting (Loader Valve)	2300 psi

Specifications taken with Mounting Kit, Hose Kit, and 72" Pin On Standard Bucket.
Specifications based on ASAE standards S301.3 and furnished for general information only as they can vary with different tractor models. Specifications are subject to change without notice and without liability therefore.

1.1. ATTACHMENT SPECIFICATIONS

BUCKET	STRUCK CAPACITY	RATED SIZE CAPACITY
54" Pin On Material	9.20 cu. ft.	10.70 cu. ft.
60" Pin On Material	10.20 cu. ft.	11.90 cu. ft.
66" Pin On Material	11.30 cu. ft.	13.20 cu. ft.
72" Pin On Material	12.30 cu. ft.	14.50 cu. ft.
78" Pin On Material	13.40 cu. ft.	15.80 cu. ft.

2. INTRODUCTION

This manual provides safety, installation, operation, maintenance, removing, storing, and reinstalling instructions for your new mid-mount loader.

Your loader has been designed to give many years of satisfactory service. Successful operation and long life of the loader depends, of course, on proper operation and care. Please read this manual carefully and follow the instructions. Correct operation and maintenance will save much time and expense.

OBSERVE and follow all CAUTION, WARNING, and DANGER instructions to help prevent personal injury and damage to the loader. The reference to right hand (RH) and left hand (LH) used in this manual refers to the position when standing at the rear of the unit and facing forward.

If, at any time, you have a service problem with your loader or need new parts, contact your local Mahindra dealer. Your dealer will need the loader model number and serial number to give you prompt, efficient service. The serial number plate is located on the LH inside front area of boom.

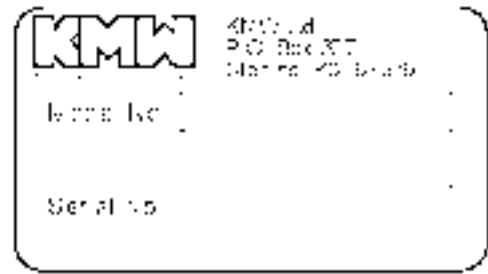

Before operating loader, check that your Dealer has covered the following information with you:

- Equipment has been completely assembled as directed.
- Equipment has been functionally tested for proper operation.
- Purchaser has been instructed in proper & safe operating methods:
 - Operators Safety Precautions
 - Tractor Wheel Tread-Tire & Inflation Recommendations
 - Tractor Hydraulic System & Loader Controls
 - Rear Ballast Recommendations
 - Hydraulic System Oil Level
 - Proper Loader Operation
 - Loader Removal
 - Loader Installation
 - Lubrication - Service Care
 - Storage
- Warranty Coverage & Operators Manual explained to purchaser.

Mahindra ML114 Loader Serial Number Information

LOADER SERIAL NUMBER _____

DATE PURCHASED _____

DEALER NAME _____

AND TELEPHONE NUMBER _____

3. INSTALLATION INSTRUCTIONS



CAUTION: Equip your tractor with a ROPS cab or frame for your protection. See your tractor/ROPS Operator Manual for correct seat belt usage.

Read entire instructions before beginning to install the loader. Personal injury and machine damage may be prevented if you read and understand these instructions and special safety messages.

When you are in the tractor seat looking forward, the RH and LH sides of the tractor and loader are the same as your right hand and left hand.

3.1. TRACTOR PREPARATION

3.1.1. Tractor Front Tires

Use front tires of equal size and maintain equal pressure in each tire. The pressure of the front tractor tires must be increased to the maximum approved pressure recommended by the tire manufacturer to compensate for additional load placed on the tires with the Front End Loader. See your tractor Operator Manual. Adjust the front tires to the widest recommended setting on adjustable models for maximum stability. Front end weights must NOT be used while loader is on the tractor.

3.1.2. Tractor Rear Tires

Maintain equal pressure in each of the rear tires. Use the widest recommended rear wheel setting for maximum stability.

3.1.3. Tractor Ballast



CAUTION: To help prevent rollover, use recommended rear tractor ballast and widest wheel settings to maximize stability. See your tractor Operator Manual for recommendations

Front tractor weights must only be used when the loader is parked. Weights must be removed before remounting loader or serious damage will occur to loader or tractor front axle due to excessive weight.

The use of adequate rear counterweight to counterbalance for maximum loader capacity is required for safe loader operation. Weight added to the rear of the tractor provides better traction and easier, more efficient loader operation.

IMPORTANT: Do not exceed the maximum load capacity of the tires on your tractor. See Tire and Wheel Specifications in tractor Operator Manual for more information.

3.1.4. Remove all loader components from shipping packaging.



WARNING: To avoid serious injury or death: Read before cutting bands or removing attaching straps. The loader may shift during shipping and handling, making it unstable on the pallet. Support loader with an overhead hoist or other suitable means prior to removing bands or attaching straps securing loader to pallet. Failure to do so could result in accidental tip-over of the loader that could cause serious injury to you and/or bystanders.



CAUTION: Lift and support all loader components safely.

3.2. MOUNTING KIT INSTALLATION

3.2.1. Position the loader on a hard level surface. The more level the surface the easier the loader is to install.

3.2.2. Remove lower horizontal exhaust covers from LH side of tractor.

3.2.3. Remove 3 engine frame bolts from each side of tractor. Save hardware.

3.2.4. Remove step from RH side of tractor. Save step and hardware.

3.2.5. Disconnect pressure, power beyond, and return hoses from hydraulic hose mount. Remove hydraulic hose mount from RH side of tractor. Save mount and hardware.



IMPORTANT: Do not tighten any hardware until all components are attached onto the tractor.



CAUTION: Lift and support all loader components safely.

Installation With Optional Grill Guard:

3.2.6. Tighten weight bracket bottom bolt securely.

NOTE: Tightening bottom bolt before removing front bolts will insure mounting holes remain aligned.

3.2.7. Remove front two bolts from weight bracket.

3.2.8. Locate front mount and optional grill guard over weight bracket. Install 14mm x 50mm hardware in these holes.

3.2.9. Position front mount spacer between rear of front mount and tractor frame. Install 5/8" x 2-1/2" hardware.

Optional Grill Guard

Front Mount

Front Mount Spacer

5/8"-11NC x 2-1/2"
Grade 5 Hex Bolt, 5/8"
Lockwasher, and Hex
Nut, 1 place each side

14mm x 2.0P x 50mm
Grade 8.8 Hex Bolt
and 9/16" Lockwasher,
2 places each side.

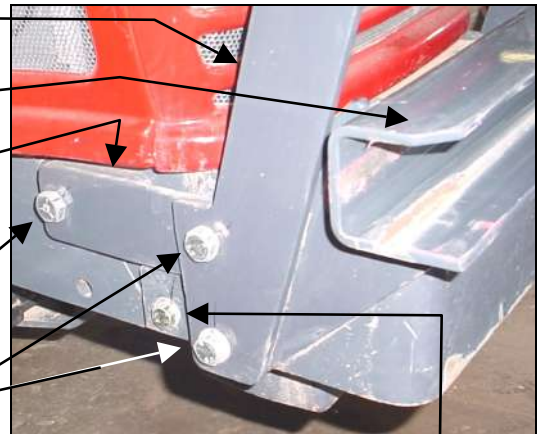

1st – Tighten Bottom Bolt Securely.

Installation Without Optional Grill Guard:

3.2.10. Tighten weight bracket bottom bolt securely.

NOTE: Tightening bottom bolt before removing front bolts will insure mounting holes remain aligned.

3.2.11. Remove front two bolts from weight bracket.

3.2.12. Locate front mount over weight bracket. Install 14mm x 40mm hardware in these holes.

3.2.13. Position front mount spacer between rear of front mount and tractor frame. Install 5/8" x 2-1/2" hardware.

Grill Guard shown is not used.

Front Mount

Front Mount Spacer

5/8"-11NC x 2-1/2"
Grade 5 Hex Bolt, 5/8"
Lockwasher, and Hex
Nut, 1 place each side

14mm x 2.0P x 40mm
Grade 8.8 Hex Bolt
and 9/16" Lockwasher,
2 places each side.

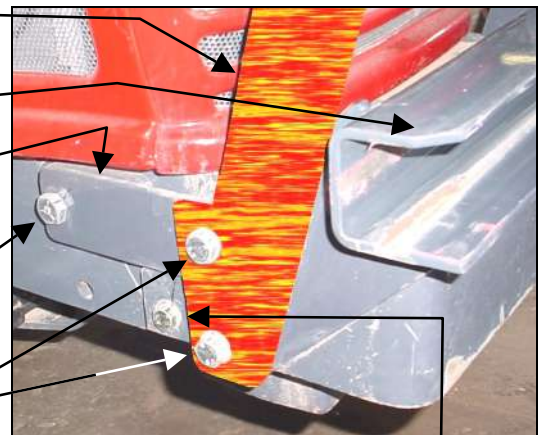

1st – Tighten Bottom Bolt Securely.

NOTE: Optional Grill Guard is shown fuzed out.

3.2.14. Remove front two bolts from RH & LH Tractor 3-point bracket. Save hardware.

3.2.15. Install RH & LH rear rail brackets to 3-point bracket using 12mm x 1.75P x 200mm Grade 8.8 hex bolts included with mounting kit plus lockwashers and nuts just removed.

Mounting Kit
12mm x 1.75P x 200mm Grade 8.8 Hex Bolt and Tractor Lockwasher and Hex Nut, 2 places.

Rear Rail Bracket
3-Point Bracket

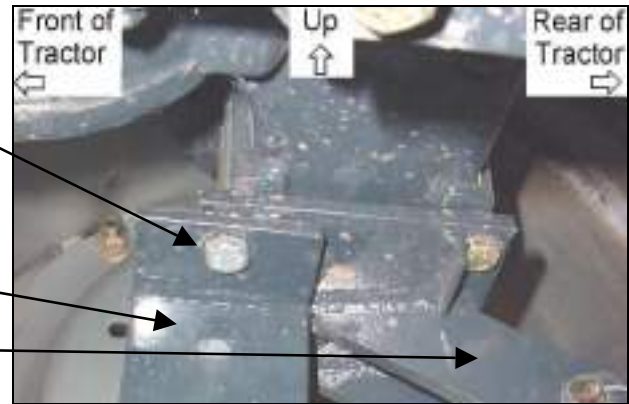

3.2.16. Install cross member to tractor engine frame. Secure using mounting kit 12mm x 45mm bolt and lockwasher just removed.

12mm x 1.25P x 45mm Grade 10.9 Hex Bolt from Mounting Kit and Tractor Lockwasher, 3 places each side.

Cross Member
Rear Rail

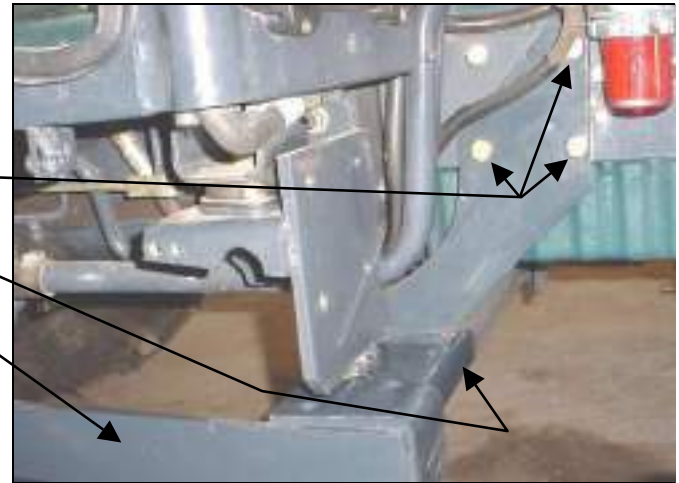

3.2.17. Lay rear rail on top of cross member on each side of tractor.

NOTE: Do not secure at this time.

3.2.18. Install RH & LH rear rails to RH & LH rear rail brackets previously installed. Secure using 1/2" x 1-1/2" hardware.

Rear Rail Bracket
Rear Rail

1/2"-13NC x 1-1/2" Grade 5 Hex Bolt, Lockwasher, Flatwasher, and Hex Nut, 2 places each side.

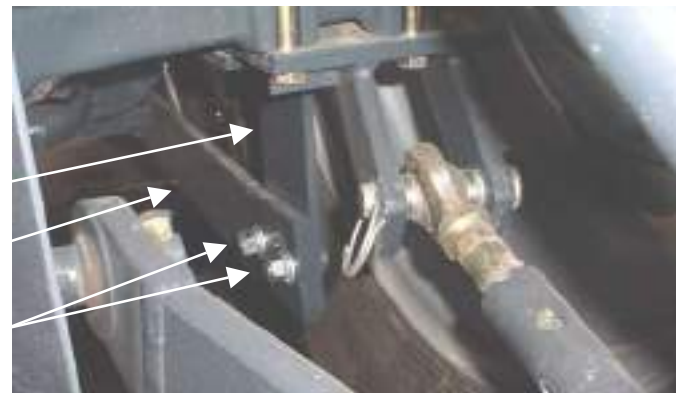

3.2.19. Reroute heater hoses underneath the cab through the channel provided by the TYM.

Heater hoses rerouted



3.2.20. Locate RH center bracket on top of rear rail and cross member. Secure to tractor using 16mm x 30mm hardware.

MARLENE - ? Lock

RH Center Bracket

16mm x 2.0P x 30mm Grade 8.8 Hex Bolt and Lockwasher, 4 places each side.

RH Rear Rail

Cross Member

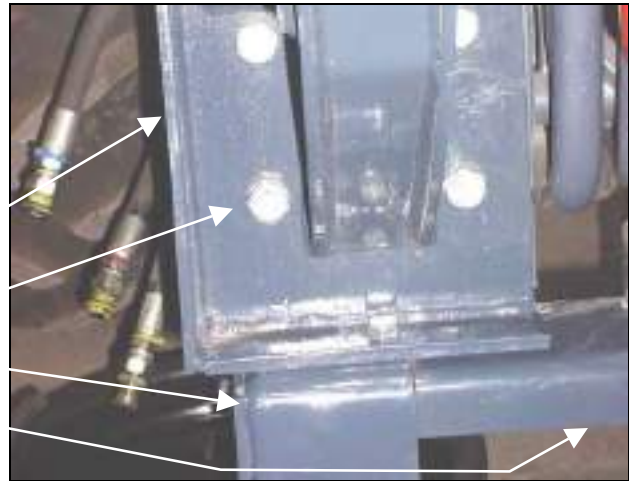

3.2.21. Locate LH center bracket on top of rear rail and cross member. Secure using 16mm x 30mm hardware.

LH Center Bracket

16mm x 2.0P x 30mm Grade 8.8 Hex Bolt and Lockwasher, 2 places each side.

Cross Member

LH Rear Rail

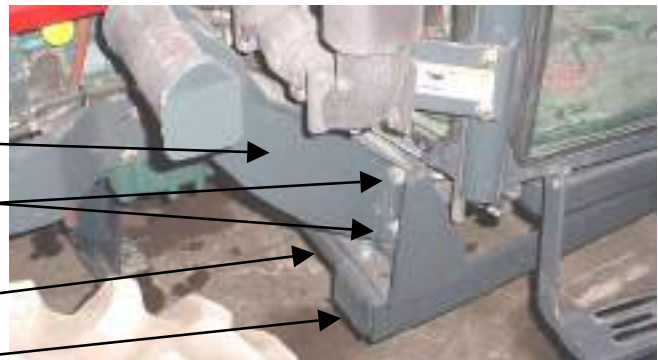

3.2.22. Align center bracket, rear rail, and cross member. Secure front side of components using 1/2" x 1-3/4" hardware.

Center Bracket

1/2"-13NC x 1-3/4" Grade 5 Hex Bolts, Lockwashers, and Hex Nuts, 1 place each side.

Rear Rail

Cross Member

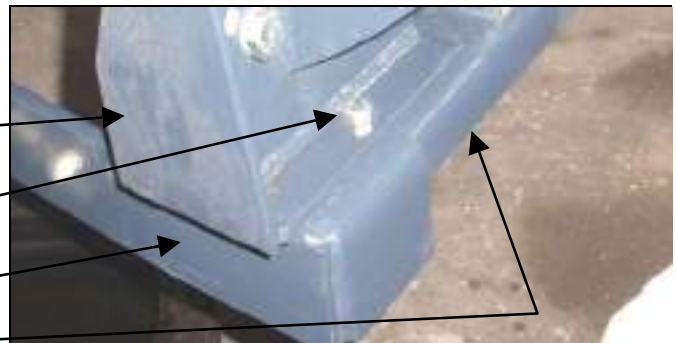

3.2.23. Secure rear side of components using 1/2" x 1-3/4" hardware.

Center Bracket

1/2"-13NC x 1-3/4" Grade 5 Hex Bolts, Lockwashers, and Hex Nuts, 2 places each side.

Cross Member

Rear Rail

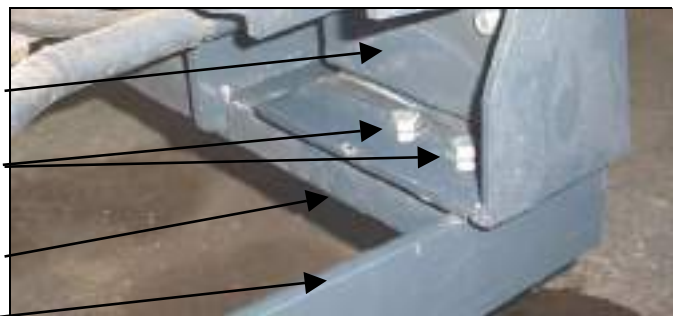

3.2.24. Rear view of rear rails mounted to cross members and rear rail brackets.

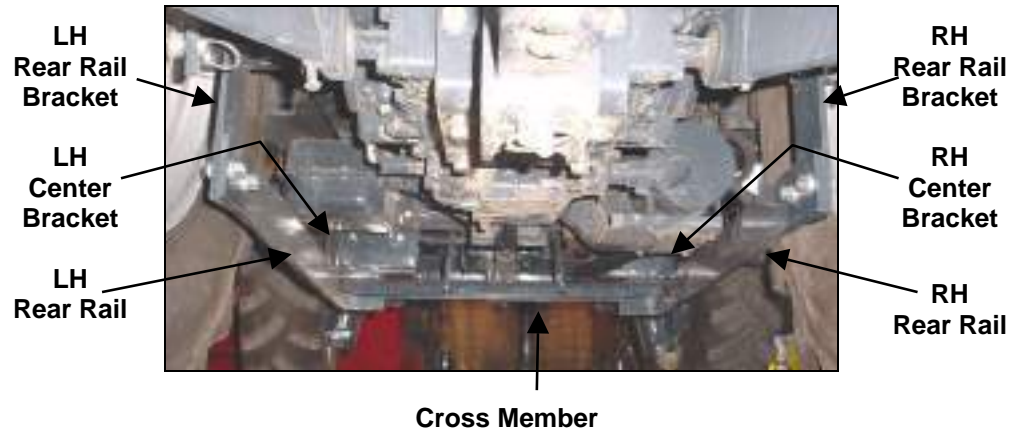

3.2.25. Verify that all mounting kit hardware has been torqued as specified before installing loader.

A. Identify hardware size and grade.

B. Refer to Torque Chart, page 62 and find correct torque for your hardware size and grade.

C. Torque hardware to this specification unless otherwise specified.

IMPORTANT NOTE: To keep mounting kit hardware from loosening during loader operation, hardware must be torqued to specifications.

3.3. HYDRAULIC INSTALLATION

3.3.1. Install 3/4" o-ring onto short end of bulkhead fitting, 4 places.

3.3.2. Install female quick coupler to o-ring/short end of bulkhead fitting, 4 places.

NOTE: O-ring must be located on correct side of bulkhead fitting or hydraulic oil leakage will occur.

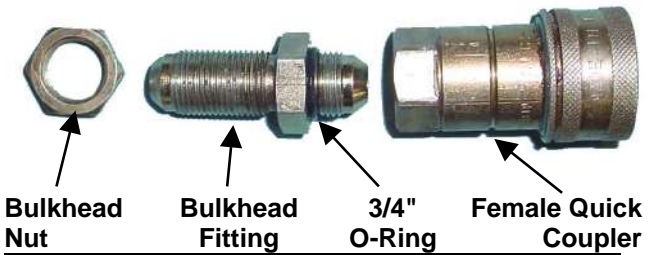

3.3.3. Install 4 o-ring/bulkhead fittings with female quick couplers to mounting plate on RH center mounting bracket. Secure using Bulkhead Nut on bottom side of mounting place.

O-ring/Bulkhead Fitting, 4 places.

Mounting Plate located on RH Center Bracket

Bulkhead Nut, 4 places.

NOTE: O-ring must be located on top side.

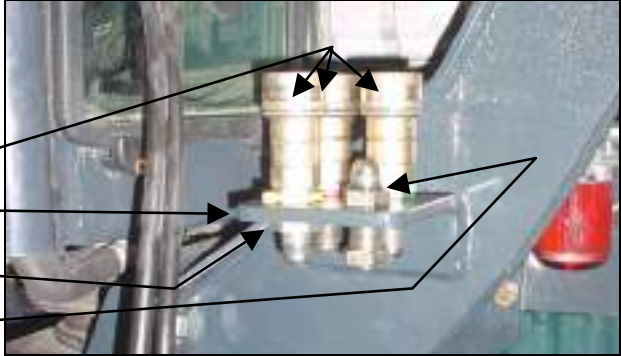

3.3.4. **Valve Assembly:** Install o-rings to (4) & (5) straight fittings.

NOTE: O-rings must be located on fittings as shown to prevent hydraulic oil from leaking.

3.3.5. Install fittings to valve as follows:

- (1) **Power Beyond "PB" Port:** Install Fitting 90° JICF 3/4" x ORBM 3/4".
- (2) **Return "OUT" Port:** Install 3/4" O-Ring to JICM 3/4" end of Straight Fitting.
- (4) **Return "OUT" Port:** Install Fitting Straight JICM 3/4" x BSPP 1/2".
- (3) **Pressure "IN" Port:** Install 3/4" O-Ring to JICM 3/4" end of Straight Fitting.
- (5) **Pressure "IN" Port:** Install Fitting Straight JICM 3/4" x BSPP 1/2".
- (6) **Port "A", "B", "C", & "D":** Install Fitting Straight JICM 9/16" x ORBM 9/16", 4 places.
- (7) **Port "A", "B", "C", & "D":** Install Fitting 90° JICM 9/16" x JICF 9/16", 4 places. Orientate 90° Fittings as shown, then tighten.

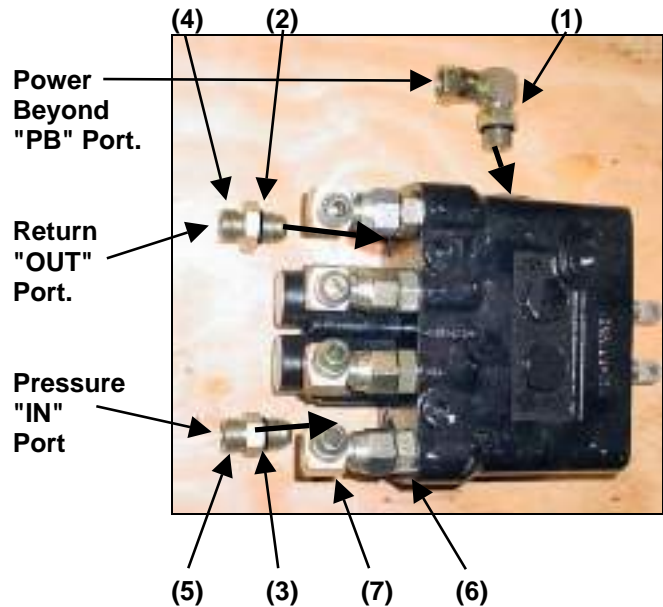

3.3.6. Install 40" hoses to working port fittings.
Ports "A", "B", "C", & "D": Install Hose 1/2" x 40" JICFS 9/16" x JICFS 3/4".

3.3.7. Using color nylon ties, install one on each working port hose. These color ties will allow easy identification of loader circuits when mounting and dismantling loader.

- Port "D" Lift Cylinder Rod End
 Blue Tie
- Port "C" Lift Cylinder Base End
 Green Tie
- Port "B" Tilt Cylinder Rod End
 Red Tie
- Port "A" Tilt Cylinder Base End
 Yellow Tie

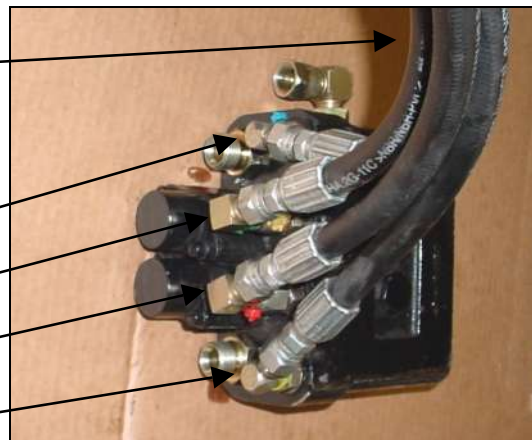

3.3.8. Install valve mount bracket to RH tractor steps using tractor step hardware.

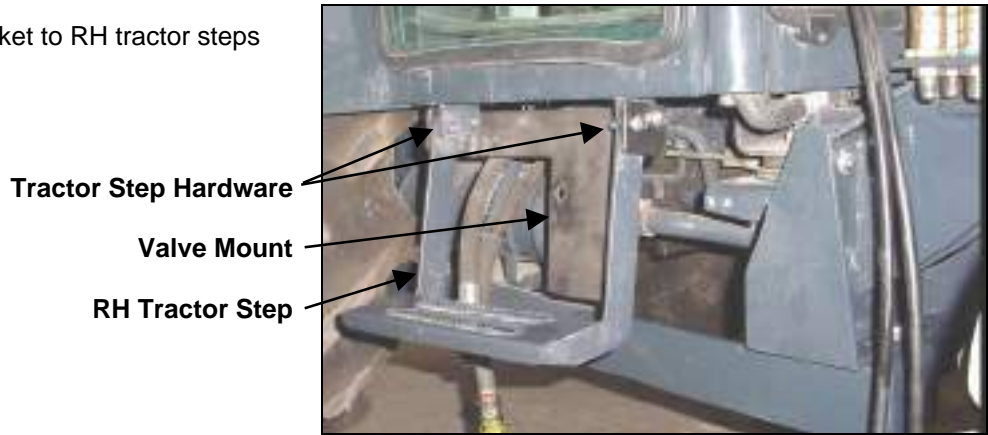

3.3.9. Secure valve to valve bracket using hardware shown.

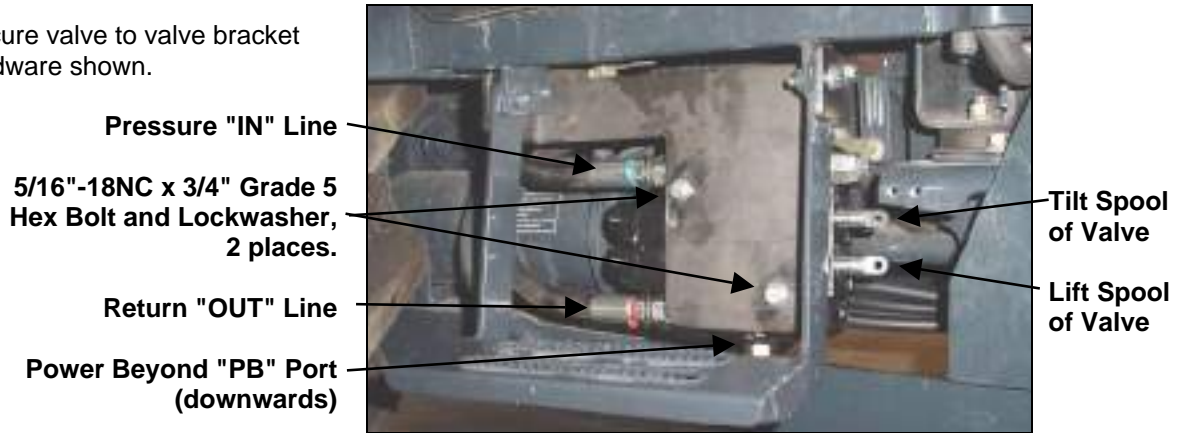

3.3.10. Attach pressure, power beyond, and return hoses to loader valve as shown.

3.3.11. Remove all twists from hoses then tighten hydraulic connections.

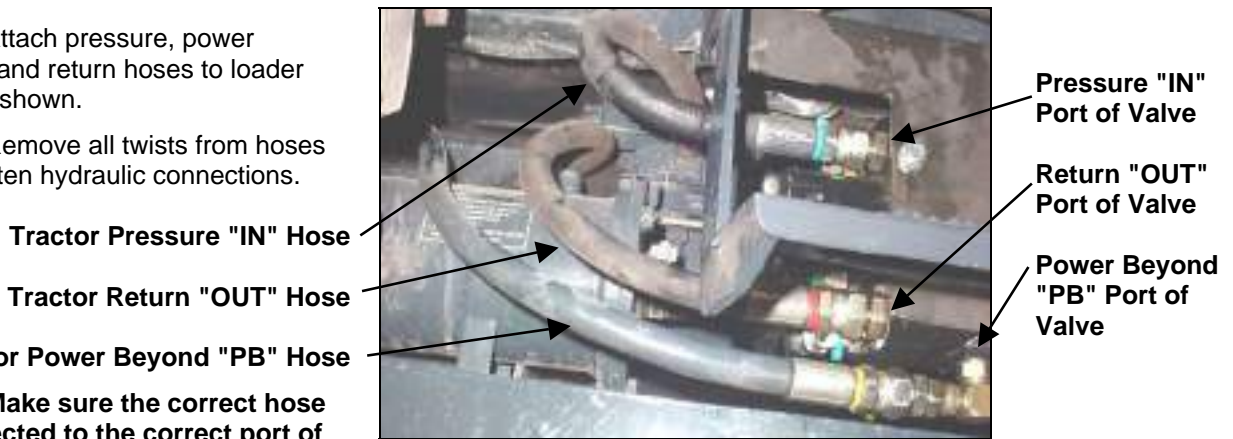

NOTE: Make sure the correct hose is connected to the correct port of valve.

3.3.12. Roll RH corner of cab rubber mat back to expose 4 mounting holes.

3.3.13. Attach controller bracket base to cab floor using hardware shown.

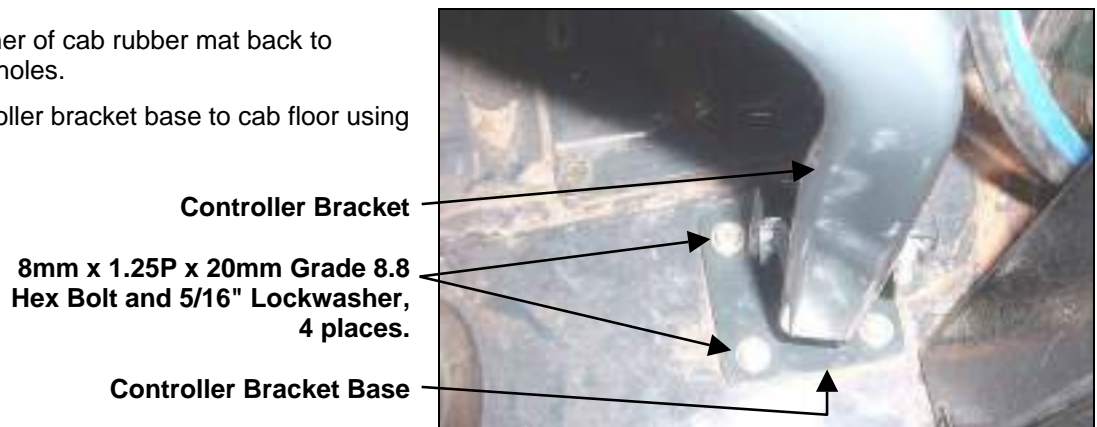

3.3.14. Install controller bracket to controller bracket base using hardware shown.

- Controller Bracket**
- 3/8"-16NC x 1-1/4" Grade 5 Hex Bolt, Lockwasher, and Nut (no Flatwasher).**
- 3/8"-16NC x 1-1/4" Grade 5 Hex Bolt, Lockwasher, Flatwasher, and Nut.**
- Controller Bracket Base**

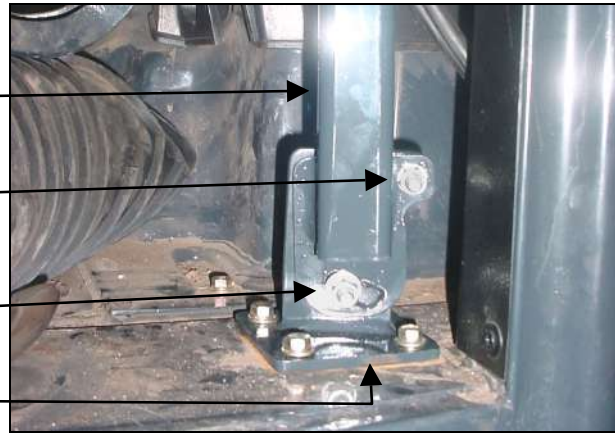

3.3.15. Cut RH cab rubber mat to fit around controller bracket. Reposition cab rubber mat on floor.

3.3.16. Install single handle controller to mounting bracket using hardware shown.

NOTE: King pin of handle must be located in position shown or loader will not function correctly.

5/16"-18NC x 4" Grade 5 Hex Bolt, Flatwasher, Lockwasher, and Hex Nut, 1 places.

- Single Handle Controller King Pin**
- Single Handle Controller**
- Controller Bracket**

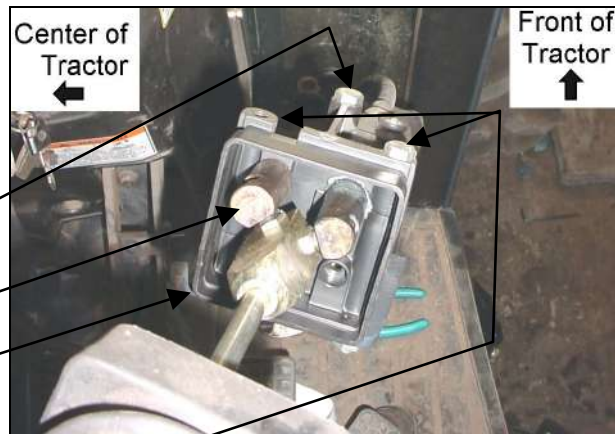

5/16"-18NC x 4" Grade 5 Hex Bolt, Lockwasher, and Hex Nut, 2 places.

3.3.17. Route cables through lower hole in cab front glass.

3.3.18. Position handle so it exposes female threads in single handle controller.

3.3.19. Install cables to single handle controller female threads and tighten cable nut.

3.3.20. Reposition single handle controller handle.

3.3.21. Secure outer portion of cables to single handle controller using single handle controller bolt.

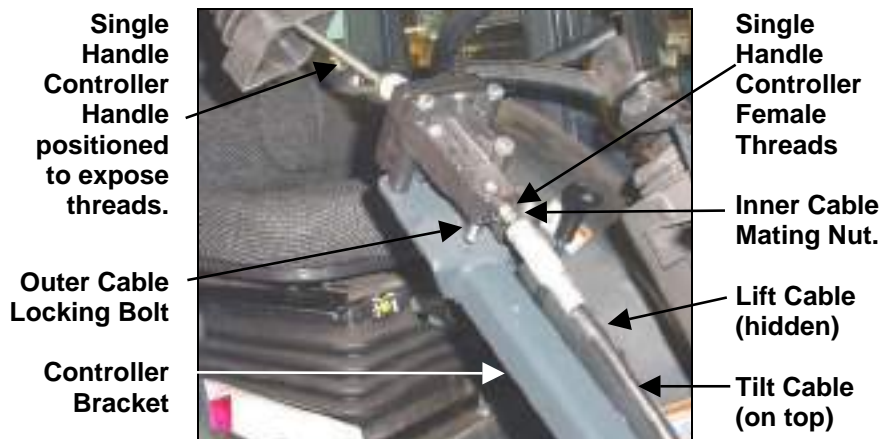

3.3.22. Install tilt cable to upper spool of valve as follows. Refer to photo and illustration below.

- A. Thread .750-16 UNF jam nut entire length of threaded hub and onto the cable.
- B. Place flange on sleeve and thread flange/sleeve assembly entire length of threaded hub and onto the cable.
- C. Thread .250-28 UNF jam nut onto cable threaded rod until it bottoms.
- D. Place connector onto threaded rod and against jam nut. Align connector so it will mate with spool terminal eye and secure jam nut against connector.
- E. Slide the connector onto spool and align the holes. Insert pin through connector and spool holes.
- F. With cable attached to valve and input device, turn the flange/sleeve assembly onto the threaded hub until it is flush with the valve face. When turning the flange/sleeve assembly, make sure that the input device remains in the neutral position.
- G. Tighten the .750-16 UNF jam nut against the sleeve to lock in position.
- H. Bring flange into position and bolt assembly to valve housing. Tighten screws sufficiently to flatten lockwashers/secure flange.

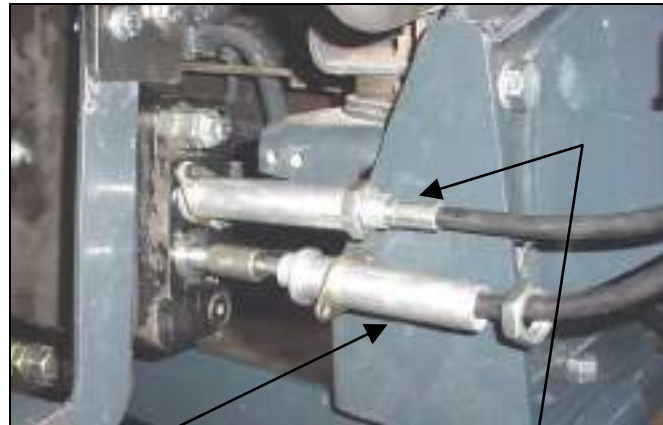

2nd Install Lift Cable to Lower Spool of Valve

1st Install Tilt Cable to Upper Spool of Valve

3.3.23. Repeat previous steps to install lift cable to lower spool of valve.

NOTE: Over-tightening will distort flange.

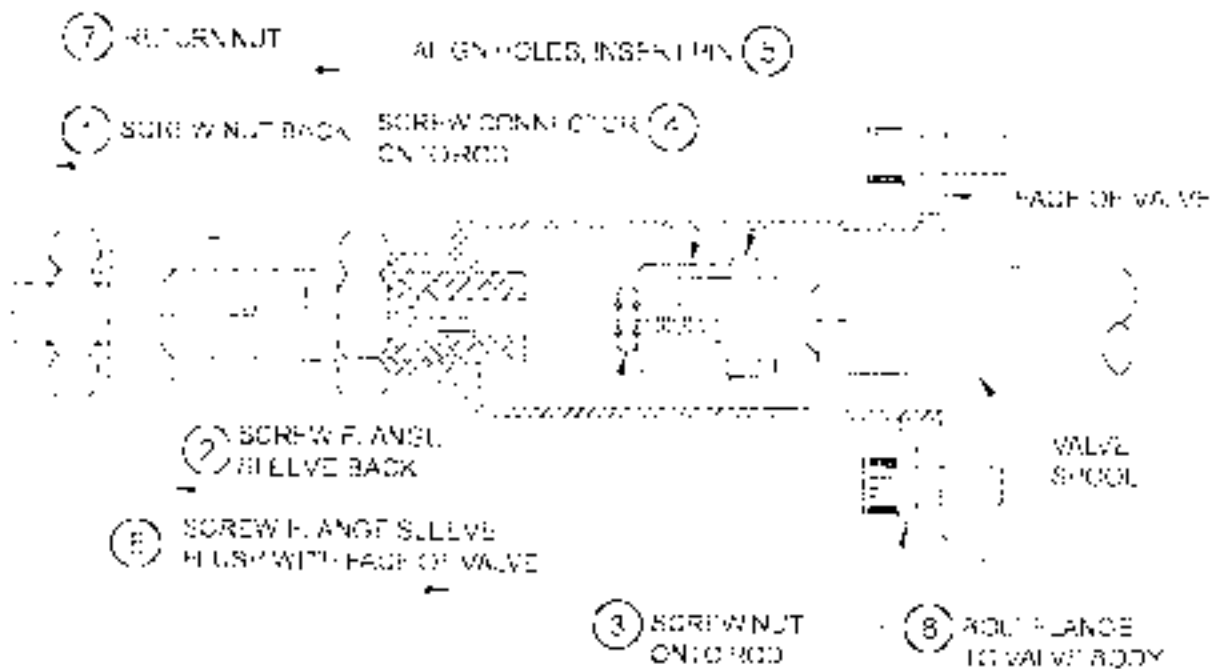

3.3.24. Adjust cables so single handle controller handle is centered, then secure cable nuts.

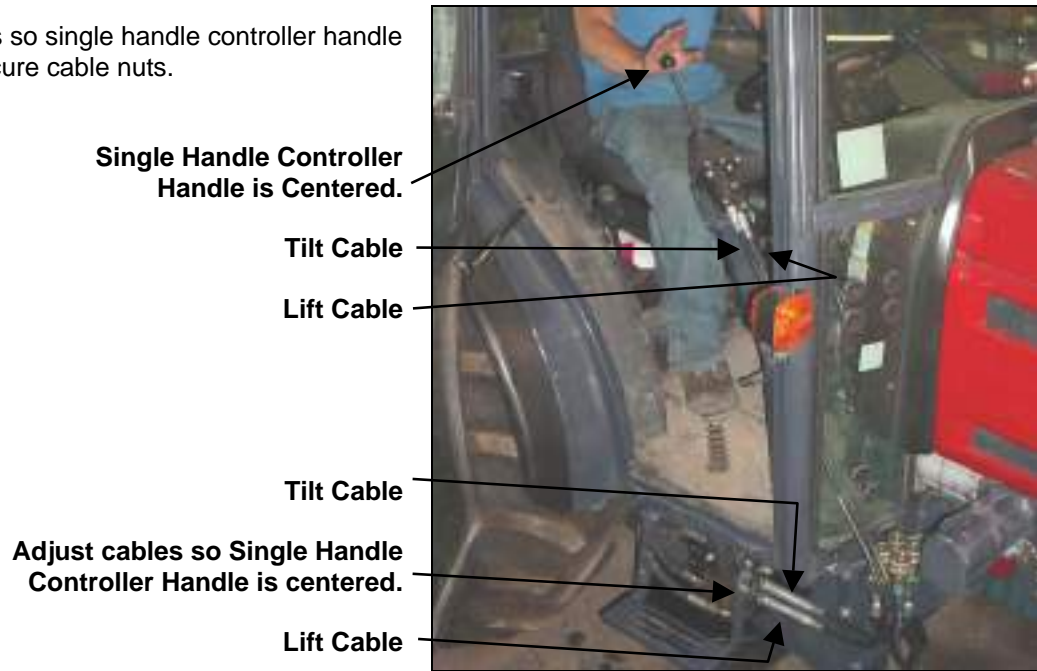

3.3.25. Connect working port hoses from loader valve to quick coupler fittings.

3.3.26. Using color nylon ties, install one on each quick coupler fitting and one on each lower hose. These color ties will allow easy identification of loader circuits when mounting and dismounting loader.

- Port "A" Tilt Cylinder Base End
 Yellow Tie
- Port "B" Tilt Cylinder Rod End
 Red Tie
- Port "D" Lift Cylinder Rod End
 Blue Tie
- Port "C" Lift Cylinder Base End
 Green Tie

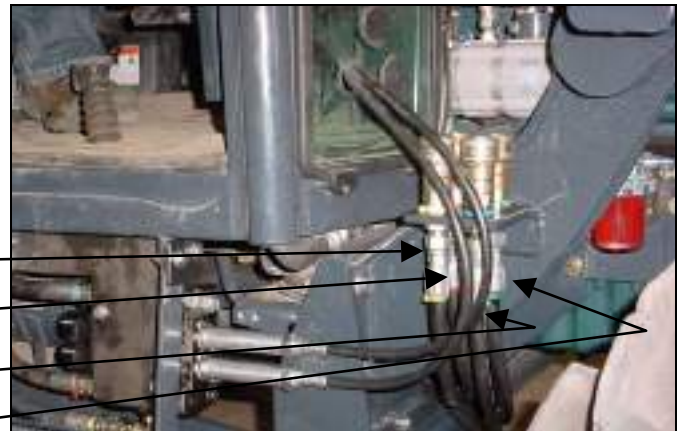

3.3.27. In full view of operator, install direction decal to cab window as shown.

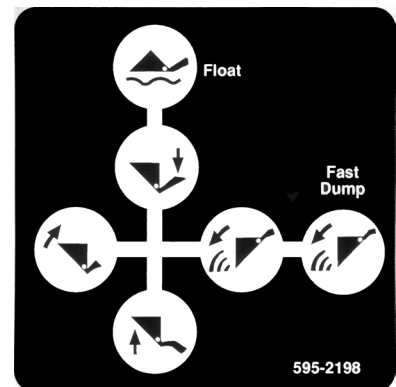

3.3.28. Check that all hydraulic connections have been tightened.