

**MITSUBISHI
TRACTOR
MT210D, 210
MT250D, 250
PARTS
CATALOGUE**

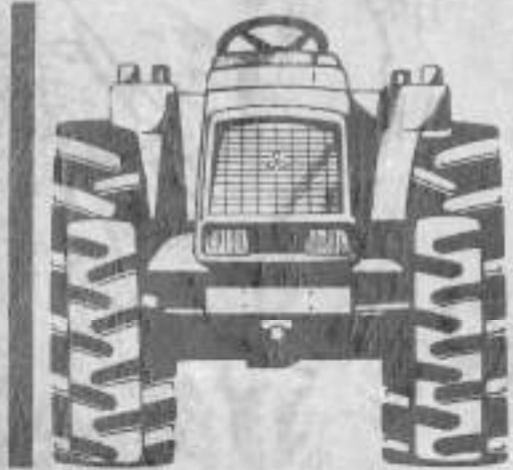

MITSUBISHI AGRICULTURAL MACHINERY CO., LTD.

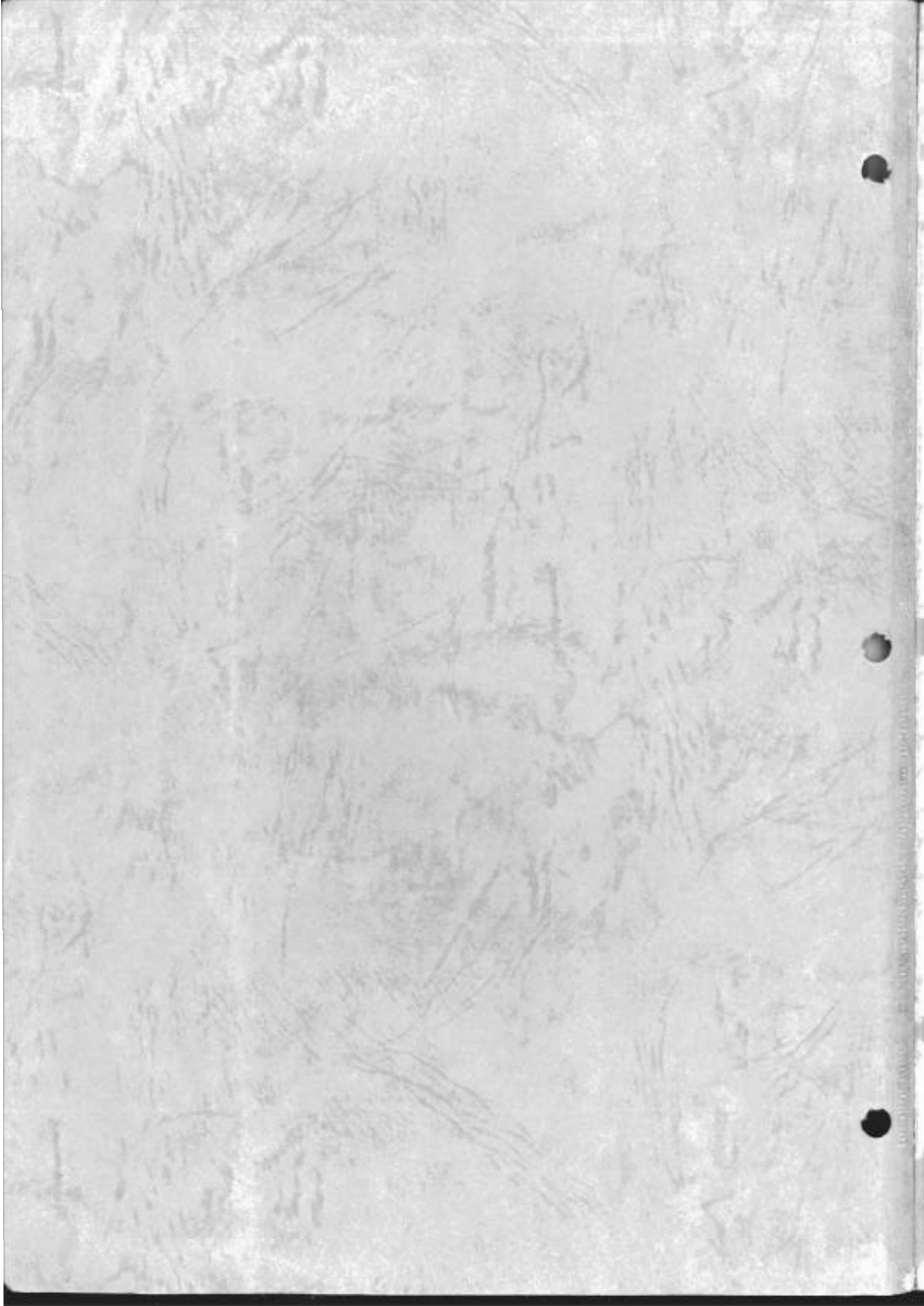

INTRODUCTION

1. Published to supersede the Part Catalogue Book No. M, 84, 05, R14 this catalogue is a list of all items of service or spare parts for the following tractors and engine.

Tractor model : MT210D (4-WHEEL DRIVE Model)
 MT210 (2-WHEEL DRIVE Model)
 MT250D (4-WHEEL DRIVE Model)
 MT250 (2-WHEEL DRIVE Model)

MODEL		EQUIPMENT					REMARKS
MT210 MT210D	MT250 MT250D	POWER STEERING	LIVE P.T.O	DRAFT CONTROL	SUPER LOW	BATTERY	
M21C,DC	M25C,DC	-	-	-	-	-	
M21CP,DCP	M25CP,DCP	○	-	-	-	-	
M21CL,DCL	M25CL,DCL	-	○	-	-	-	
M21CR,DCR	M25CR,DCR	-	-	○	-	-	
M21CPL,DCPL	M25CPL,DCPL	○	○	-	-	-	
M21CPR,DCPR	M25CPR,DCPR	○	-	○	-	-	
M21CLR,DCLR	M25CLR,DCLR	-	○	○	-	-	
M21CPLR,DCPLR	M25CPLR,DCPLR	○	○	○	-	-	
	M25,D	-	-	-	-	○	
	M25P,DP	○	-	-	-	○	
	M25L,DL	-	○	-	-	○	
	M25R,DR	-	-	○	-	○	
	M25PL,DPL	○	○	-	-	○	
	M25PR,DPR	○	-	○	-	○	
	M25LR,DLR	-	○	○	-	○	
	M25PLR,DPLR	○	○	○	-	○	
	M25DRU	-	-	○	-	○	
	M25DLU	-	○	-	-	○	
	M25DLRU	-	○	○	-	○	
	M25FL,DFL	-	○	-	-	○	Central Europe
	M25FRS,DFRS	-	-	○	○	○	
	M25FLR,DFLR	-	○	○	-	○	
	M25F,DF	-	-	-	-	○	
	M25DFPS	○	-	-	○	○	Middle East
	M25DYR	-	-	○	○	○	
	M25DYPR	○	-	○	○	○	

Engine model : K3D-13MT (MT210D, MT210)
 K3H-11A (MT250D, MT250)

2. The Book Number of this Parts Catalogue is M, 86, 04, R03
3. The part number contains the letter, C, G, T or N : this indicates the color as follows:

C : dark gray	T : blue
G : white	N : black (matted)
K : black	J : black

4. Listed below are the symbols and abbreviations appearing in this Parts Catalogue:

4.1 Symbols

*		This mark appearing in "Part No." column indicates parts not to be supplied.
New part Old part	A	New and old parts are mutually interchangeable.
New part Old part	B	New part can be substituted for old part, but not vice versa. Thus, new part may be supplied to order asking for supply of old part.
New part Old part	D	New and old parts are not interchangeable.
Added part		Indicated as "Added" in "Interchangeability" column. Its applicable serial number of tractor or engine appears in "Remarks" column.
<p>○ : Old parts will be supplied until out of stock and thereafter new substitute parts will be supplied. (This mark appears in "Part No." column and corresponding old part numbers in "Remarks" column.)</p> <p>Tractor or engine serial numbers:</p> <p>~□□□□□□□ Up to □□□□□□□□</p> <p>□□□□□□□ ~ □□□□□□□ and up</p>		

4.2 Abbreviations

ASSY. : assembly	*L.H. : left hand	4WD	: MT210D,MT250D
AR : as required	*R.H. : right hand	2WD	: MT210,MT250
C : choice (selective use)	OP. : optional	210D,210	: MT210D,MT210
d : diameter	OS. : oversize	250D,250	: MT250D,MT250
*Fr. : front or forward	STD : standard	P/S	: power steering
*Re. : rear or rearward	t : thickness	DRAFT	: draft control
ℓ : length	US. : undersize	LIVE	: LIVE P.T.O
S/L : super low	S : set		

* The terms "left hand," "right hand," "front" and "rear" are as these directions would appear from the operator's seat facing forward

5. The 11-digit part numbers of bolts contain the letter (prefix) A, F or H; this indicates how bolts are supplied, as cited below:

- A: ordinary bolt
- F: bolt with spring washer
- H: bolt with spring washer and plain washer

INSTRUCTIONS FOR ORDERING PARTS

When ordering parts, give the following information:

EXAMPLE:

Model	Part No.	Part name	Q'ty
MT250D	1984 1213 000	COLLAR	1

THE IMPORTANCE OF GENUINE MITSUBISHI PARTS

Satisfactory and efficient service in the operation of your tractor is endangered by the use of inferior parts – in most cases, imitations, as such cheap parts invariably mean short life and high cost.

MITSUBISHI bears the full responsibility for the quality and fit of each part it supplies. Dealers carrying out repairs on MITSUBISHI products are urged to use **ONLY GENUINE PARTS** in order that the tractor may be maintained in the best possible operating conditions. The use of any part other than the **GENUINE MITSUBISHI PART** releases MITSUBISHI from any guarantee.

IMPLMENT

ASSY. NAME	ASSY. NUMBER	TRACTOR MODEL				REMARKS
		MT210	MT210D	MT250	MT250D	
WEIGHT FRONT WHEEL	1158 5170 0C1	○	—	○	—	4pcs./1set 12.5kg/1pcs.
WEIGHT REAR WHEEL	1167 5530 0C2	○	○	○	○	4pcs./1set 34kg/1pcs.
* BUMPER WEIGHT	1982 5040 0C0	○	○	○	○	
* FRONT P.T.O KIT	1984 5010 0C0	○	○	—	—	
* FRONT P.T.O KIT	1984 5020 0C0	—	—	○	○	
* ADAPTER KIT	1021 6040 000	○	○	○	○	
DRAFT CONTROL KIT	1984 6200 0C0	○	○	○	○	
* SUB CONTROL VALVE	1021 6000 0C1	○	○	○	○	
* SUB CONTROL VALVE	1021 6020 0C1	○	○	○	○	
* TAIL PIPE COVER	1982 5301 0K1	○	○	○	○	
ROTARY TILLER	1984 7100 0T0	○	○	○	○	MODEL MR-40
SPECIAL TOOL	1984 9000 000	○	○	○	○	
SUB CONTROL KIT	1984 610A 000	○	○	○	○	
SUB CONTROL KIT	1984 610B 000	○	○	○	○	
M KIT	1984 7000 000	—	—	○	○	

* See chapter 9

GROUP INDEX

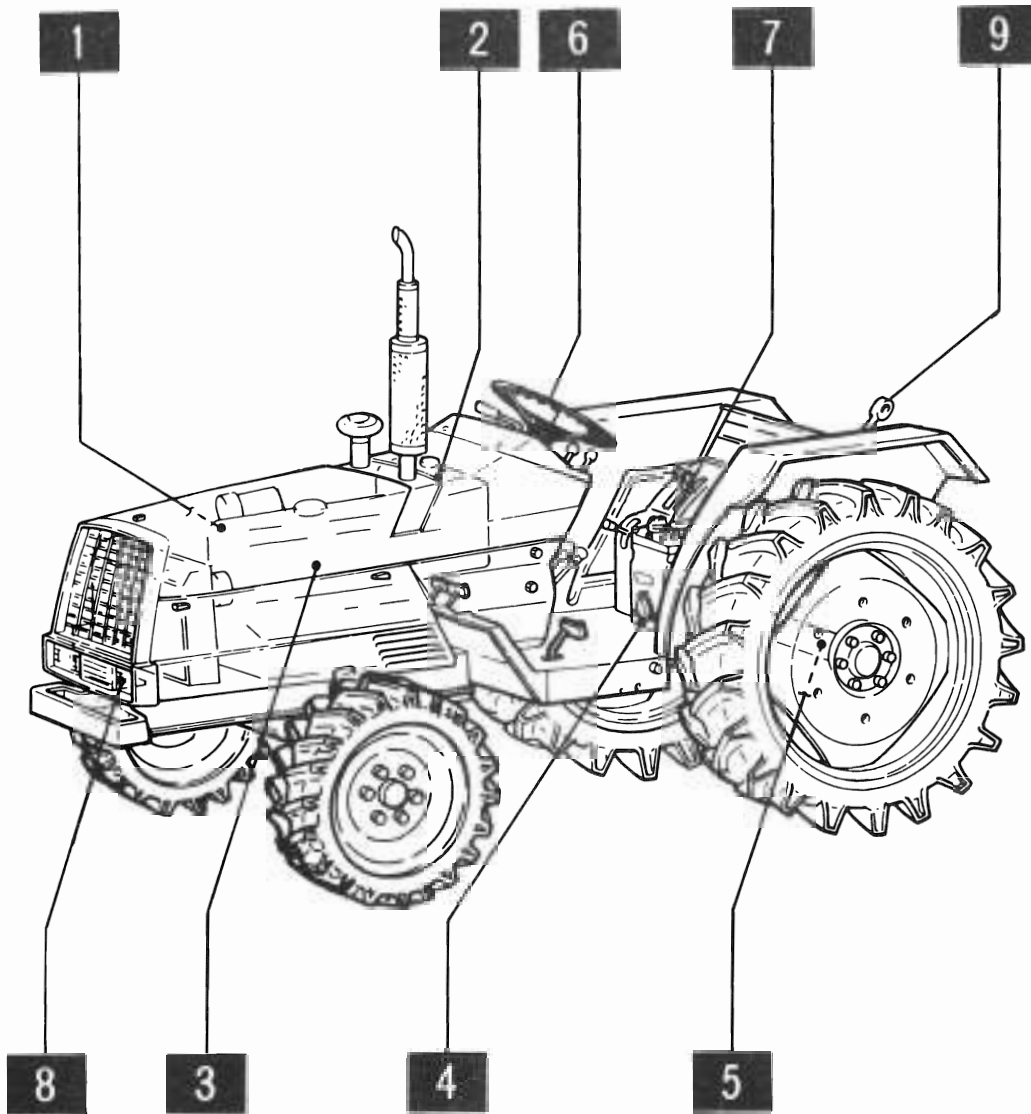

GROUP INDEX

ENGINE

CHASSIS

ENGINE RELATIONAL PARTS

FRAME

POWER LINE

AXLE & BRAKE

DRIVING CONTROL

HYDRAULIC SYSTEM

ELECTRICAL SYSTEM

ACCESSORY

NUMERICAL PARTS INDEX

1

2

3

4

5

6

7

8

9

CONTENTS

FIG No SUBJECT PAGE

ENGINE

1 K3D-13MT (MT210D,210)

101	CRANK CASE	2
102	OIL PAN & GEAR CASE	4
103	CYLINDER HEAD	5
104	MAIN MOVING PARTS	6
105	TIMING PARTS	8
106	FUEL SUPPLY PARTS	9
107	FUEL INJECTION PUMP	10
108	NOZZLE & NOZZLE HOLDER	12
109	FUEL FILTER	13
110	GOVERNOR & CONTROL PARTS	14
111	OIL PUMP	16
112	LUBRICATING PARTS	17
113	COOLING PARTS (1/2)	18
114	COOLING PARTS (2/2)	19
115	INTAKE & EXHAUST PARTS	20
116	ELECTRICAL EQUIPMENT	21
117	STARTER	22
118	ALTERNATOR	23
119	REPAIR GASKET KIT	24

1 K3H-11A (MT250D,250)

121	CRANK CASE (1/2)	26
122	CRANK CASE (2/2)	27
123	OIL PAN & GEAR CASE	28

CONTENTS

FIG No.	SUBJECT	PAGE
124	CYLINDER HEAD	29
125	MAIN MOVING PARTS	30
126	VALVE MECHANISM	32
127	TIMING PARTS	33
128	FUEL SUPPLY PARTS	34
129	FUEL INJECTION PUMP	35
130	NOZZLE & NOZZLE HOLDER	37
131	FUEL FILTER	38
132	GOVERNOR & CONTROL PARTS (1/2)	39
133	GOVERNOR & CONTROL PARTS (2/2)	40
134	OIL PUMP	41
135	LUBRICATING PARTS	42
136	FAN & WATER PUMP	43
137	COOLING PARTS	44
138	INTAKE & EXHAUST PARTS	45
139	ELECTRICAL EQUIPMENT	46
140	STARTER	47
141	ALTERNATOR	48
142	REPAIR GASKET KIT	49

CHASSIS

2 ENGINE RELATIONAL PARTS

201	FUEL LINE	52
202	MUFFLER (210D, 210)	55
203	MUFFLER (250D, 250)	56
204	RADIATOR	57

CONTENTS

FIG.No.	SUBJECT	PAGE
205	AIR CLEANER	59
206	AIR CLEANER (For MIDDLE EAST)	60
3 FRAME		
301	BONNET (1/4)	61
302	BONNET (2/4)	62
303	BONNET (3/4)	63
304	BONNET (4/4) (For MIDDLE EAST)	65
305	SEAT & TOOL BOX	66
305A	SEAT & TOOL BOX	68
306	FENDER	70
307	STEP	73
4 POWER LINE		
401	CLUTCH HOUSING & CLUTCH	74
402	TRANSMISSION HOUSING	76
403	DRIVE & COUNTER SHAFT	77
404	MAIN SHAFT	79
405	COUNTER P.T.O SHAFT (STD)	80
406	COUNTER P.T.O SHAFT (LIVE P.T.O & S/L)	81
407	P.T.O SHAFT	83
408	SUB P.T.O SHAFT (1/2)	84
409	SUB P.T.O SHAFT (2/2)	85
410	CLUTCH (LIVE P.T.O)	86
411	FINAL DRIVE	87
5 AXLE & BRAKE		

CONTENTS

FIG.No.	SUBJECT	PAGE
501	REAR AXLE	90
502	PROPELLER SHAFT (4WD)	92
503	FRONT AXLE BRACKET (4WD)	93
504	FRONT DIFFERENTIAL (4WD)	94
505	FRONT AXLE GEAR CASE (4WD)	95
506	TIE ROD & DRAG LINK (4WD)	97
507	FRONT AXLE BRACKET (210)	99
508	KNUCKLE ARM (210:10166~)	101
509	TIE ROD & DRAG LINK (210:10166~)	102
510	TIE ROD & DRAG LINK (210:~10165)	104
511	FRONT AXLE BRACKET (250)	106
512	KNUCKLE ARM (250)	108
513	TIE ROD & DRAG LINK (250)	109
514	FRONT & REAR WHEEL (210D/210 AG TIRE)	111
515	FRONT & REAR WHEEL (250D/250 AG TIRE)	112
516	FRONT & REAR WHEEL (ES TIRE)	113
517	FRONT & REAR WHEEL (WT TIRE)	114
518	FRONT & REAR WHEEL (210D/250D AG TIRE)	115
519	FRONT & REAR WHEEL (WTT TIRE)	116

6 DRIVING CONTROL

601	ENGINE CONTROL	117
602	TRANSMISSION CONTROL LEVER	119
603	P.T.O CONTROL LEVER	120
604	SUB CHANGE LEVER	121
605	CLUTCH & BRAKE CONTROL (1/2)	123
606	CLUTCH & BRAKE CONTROL (2/2) (LIVE P.T.O)	125

CONTENTS

FIG.No.	SUBJECT	PAGE
607	STEERING	127
608	STEERING GEAR BOX	128
609	STEERING (P/S)	131
610	STEERING GEAR BOX (1/2) (P/S)	132
611	STEERING GEAR BOX (2/2) (P/S)	133
7 HYDRAULIC SYSTEM		
701	HYDRAULIC LIFT	135
702	HYDRAULIC CYLINDER	136
703	HYDRAULIC CONTROL VALVE	138
704	POSITION CONTROL	139
705	DRAFT CONTROL (DRAFT)	141
706	DRAFT BRACKET (DRAFT)	143
707	CONTROL VALVE & COVER	145
708	HYDRAULIC LINE (STD)	146
709	HYDRAULIC LINE (P/S) (1/2)	148
710	HYDRAULIC LINE (P/S) (2/2)	150
711	HYDRAULIC LINE (LIVE P.T.O) (1/2)	152
712	HYDRAULIC LINE (LIVE P.T.O) (2/2)	154
713	HYDRAULIC LINE (P/S & LIVE P.T.O) (1/2)	156
714	HYDRAULIC LINE (P/S & LIVE P.T.O) (2/2)	158
715	HYDRAULIC PUMP	160
716	FLOW DIVIDER (P/S LIVE P.T.O)	161
717	DIVIDER (P/S LIVE P.T.O)	162
8 ELECTRICAL SYSTEM		
801	ELECTRICAL WIRING	163

CONTENTS

FIG.No.	SUBJECT	PAGE
802	ELECTRICAL PARTS	166
803	METER PANEL (1/2)	168
804	METER PANEL (2/2)	170
9 ATTACHMENT & ACCESSORY		
901	NAME PLATE (210D,210)	172
902	NAME PLATE (250D,250)	173
903	TOOLS	175
904	THREE POINT LINKAGE (1/2)	176
905	THREE POINT LINKAGE (2/2)	178
906	TOOLS	179
907	BUMPER WEIGHT & TAIL PIPE COVER	180
908	FRONT P T O	181
909	ADAPTER KIT	182
910	EXTERNAL HYDAULIC KIT	183
911	DRAFT CONTROL KIT	184
912	SPECIAL TOOLS	185
NUMERICAL PARTS INDEX		188

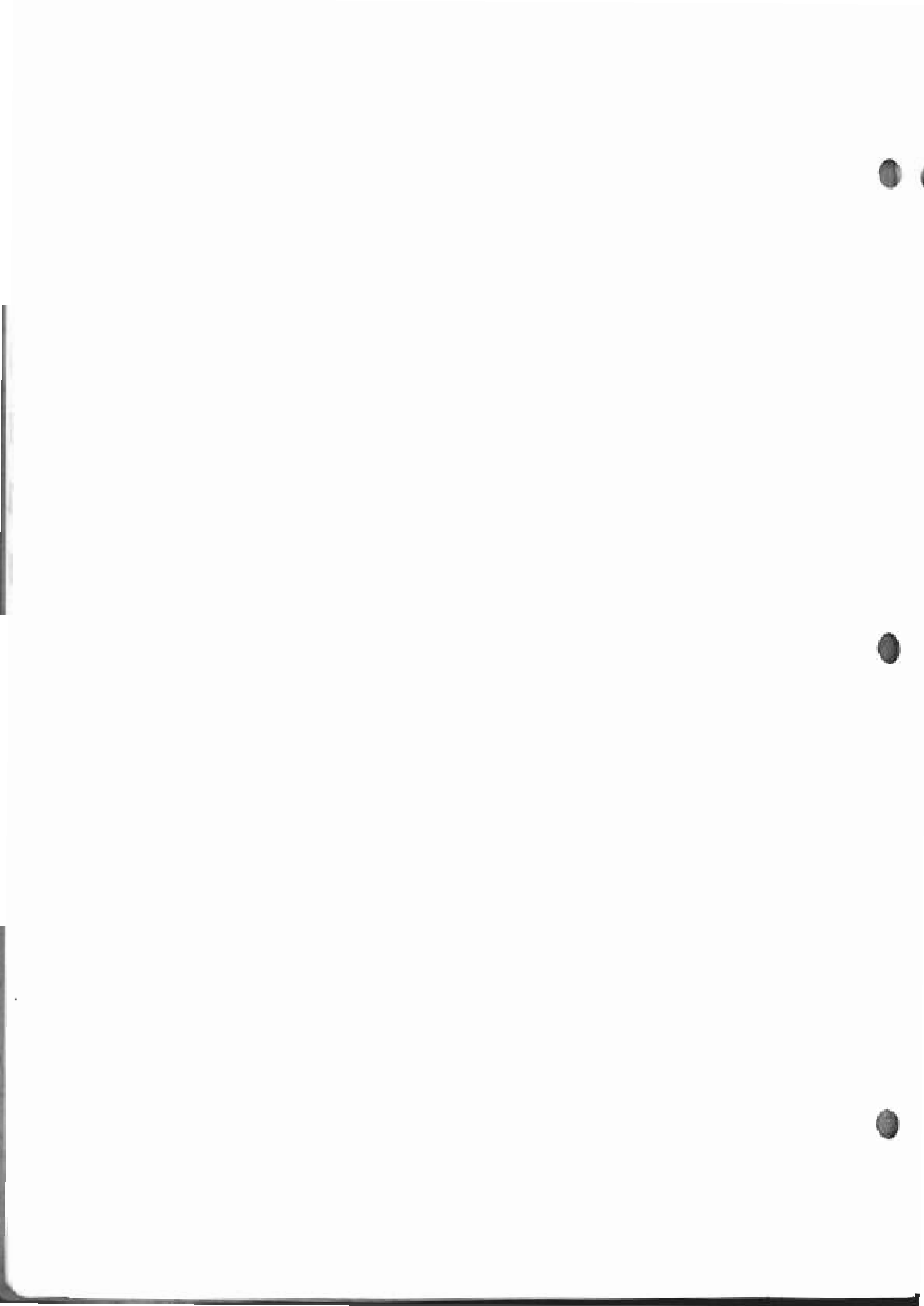

ENGINE

MT210D, 210 (K3D-13MT)

FIG. 101 CRANK CASE



Key No	Part No	Part Name	QTY	Application	Description	Remarks
1	MM409615	PIN,dowel	2			
	○	PIN,dowel	2	A		0260250
2	MM406229	SEAL,side	2			
3	MM430613	CU DE,gauge	1			
	○	CU DE,gauge	1	A		027-00215
4	MM406242	SEAL,o	1			
5-10	MM413883	CYLINDER BLOCK	1			
	○	CYLINDER BLOCK	1	A		MM404135
E	*	CASE,crank	1			
6	MM406217	BOLT	8			
7	*	CAP,assy	1			
8	MF665538	CAP,sealing	2			125
9	MF665543	CAP,sealing	2			143
10	MM408176	ELSH'NG	1			
11	MM430113	SHAFT,idler	1			
	○	SHAFT,idler	1	A		02602129
12	MM408220	CASE,cr sea	1			
13	MM408225	GASKET	1			
14	MM408221	PLATE front	1			
15	MM408225	GASKET	1			
16	MF240054	BOLT,w/washer	5			028x12
17	MF240051	BOLT,w/washer	3			028x10
	○	BOLT,w/washer	3	A		028x10 02602127
18	MF412404	PIN,dowel	1			
19	MF665511	PLUG,expansion	1			211
20	MS471104	BL,SH NG,knock	2			
21	MS471105	BL,SH NG,knock	2			
22	MS471110	BL,SH NG,knock	1			
23	MS6E1141	PLUG,taper	2			
	○	PLUG,taper	2	A		02602128
24	MM408260	JOINT	1			
25	MF402636	STUD	2			014x10
26	MM408160	BEARING,SE	1			02602129
	MM408161	BEARING,SE	1			02602129
	MM408162	BEARING,SE	1			02602129

FIG. 101 CRANK CASE

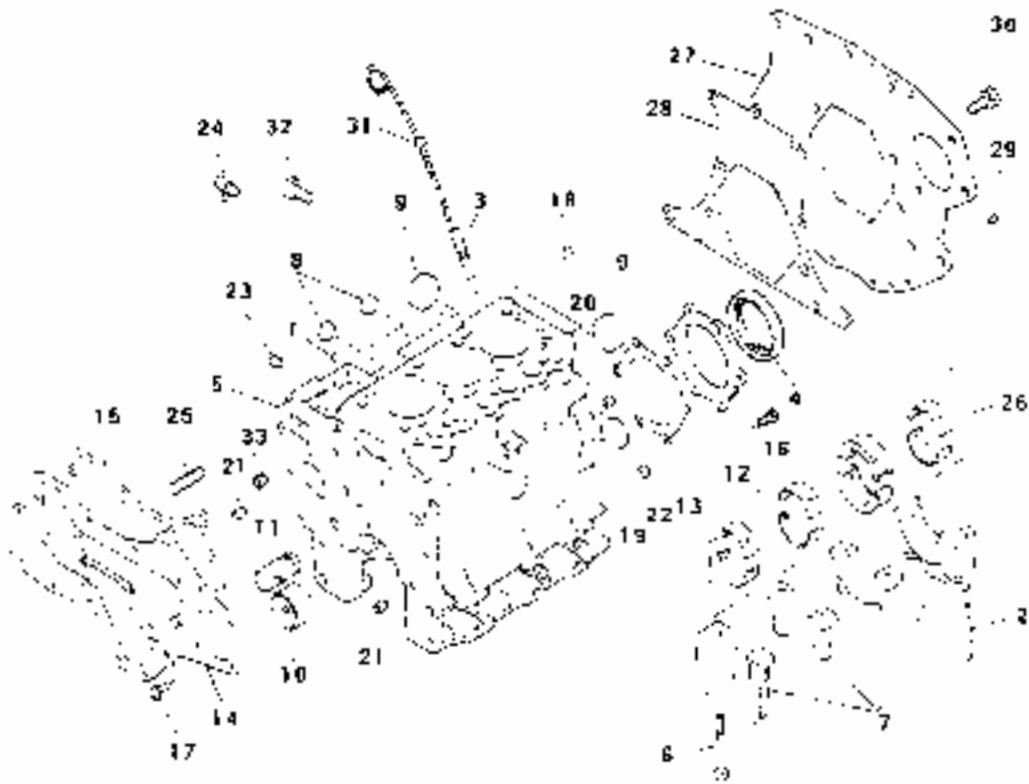

Key No.	Parts No.	Parts Name	Q'ty			Application	Description	Remarks
			ALL	I	P			
	MM408163	BEARING SET	1				0.75 U.S.	
27	MM412671	PLATE, rear	1					
28	MM409577	GASKET	1					
29	MM408240	PIN, knock	1				part 0	
30	MF241308	BOLT, w/washer	6				M-2033	
31	MM412652	GAUGE	1			10151		MM409722
	C	GAUGE	1			A		
32	MF100110	BOLT	4				M-2033	
33	MS66121	PLUG, taper	1				PT 1-4	

FIG.102 OIL PAN & GEAR CASE

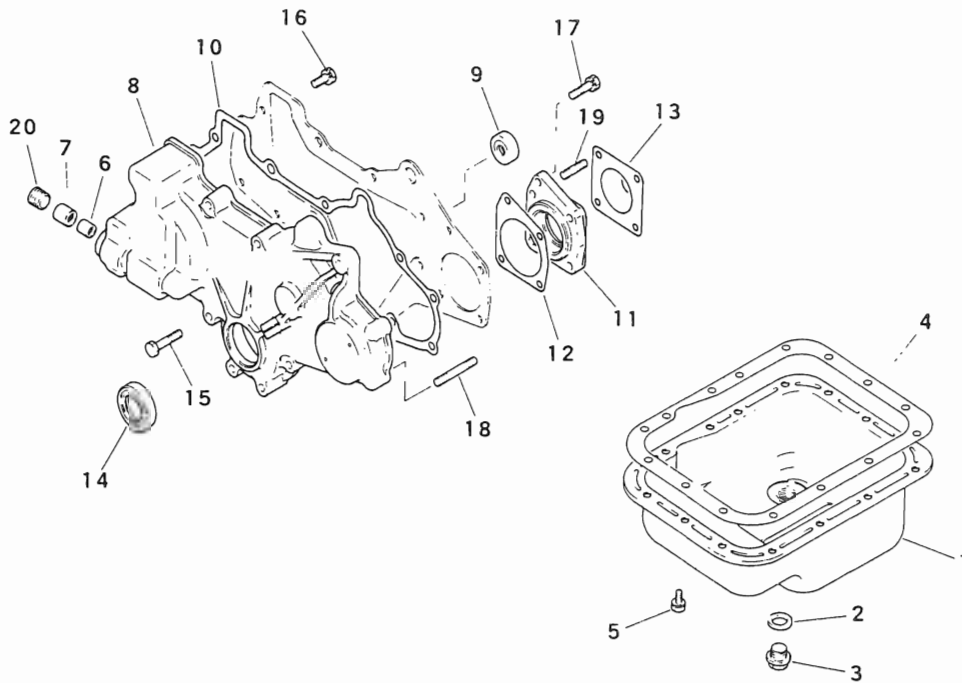

Key No	Parts No	Parts Name	Q'ty					P/P	Application	Description	Remarks
			ALL								
1-3	MM412636	OIL PAN ASS'Y	1								
1	*	PAN,oil	1								
2	MD000312	GASKET	1						φ18		
3	MD000318	PLUG,oil drain	1								
4	MM408321	GASKET,oil pan	1								
5	MF240051	BOLT,w/washer	15						M8X16		
6	MM406420	BEARING,needle	1								
7	MM406421	BEARING,needle	1								
8	MM408227	CASE,gear	1								
9	MM409718	PLUG,thrust	1								
10	MM408235	GASKET	1					8838 ~			
	○	GASKET	1					A		MM408236	
11	MM409230	HOUSING	1								
12	MM409235	GASKET,housing	1								
13	MM401206	GASKET	1								
14	MD008762	SEAL,oil	1					35704 ~			
	○	SEAL,oil	1					A		K9413390	
15	MF100064	BOLT	8						M8X45		
16	MF240051	BOLT,w/washer	2					22139 ~	M8X16		
	○	BOLT,w/washer	2					A	M8X20	MF240053	
17	MF241257	BOLT,w/washer	1						M8X30		
18	MS401434	STUD	3						M8X42		
19	MF402565	STUD	1						M8X22		
20	MS661123	PLUG,taper	1						PT = 1/2		

FIG. 103 CYLINDER HEAD

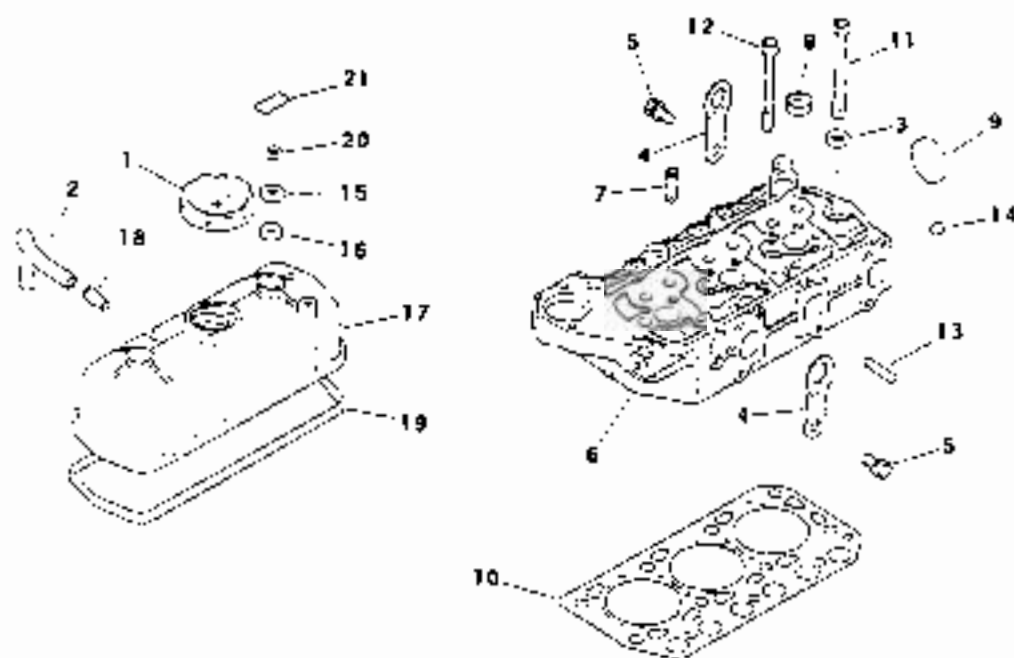

Key No	Parts No	Parts Name	Q'ty		Application	Description	Remarks
			ALL				
1	MD006784	CAP,oil filter	1				
2	MM432044	PIPE,breather	1		261-3-		
	○	PIPE,breather	1		B		MM408518
3	MD020733	WASHER	8				
4	MM408470	HANGER,engine	2				
5	MF241280	BOLT,w/washer	2			W10X20	
6-9	MM408394	CYLINDER HEAD	1				
6	*	HEAD,cylinder	1				
7	MM408441	GUIDE, valve	6				
8	MF665536	CAP,sealing	3			625	
9	MF665543	CAP,sealing	1			645	
10	MM408453	GASKET	1				
11	MM408461	BOLT	8			W12X38	
12	MM404316	BOLT	3			W10X30	
13	MF401336	STUD	1			W8X25	
14	MS661140	PLUG,taper	1		30574-		
	○	PLUG,taper	1		A	PL 118	MS66-120
15	MM408509	WASHER	2				
16	MD000523	SEAL,oil	2				
17 18	MM408491	ROCKER COVER	1				
17	*	COVER,rocker	1				
18	K9644171	PIPE	1				
19	MM408501	GASKET	1				
20	MF430005	NUT	2			W8	
21	MM412726	LABEL,model	1				

FIG. 104 MAIN MOVING PARTS

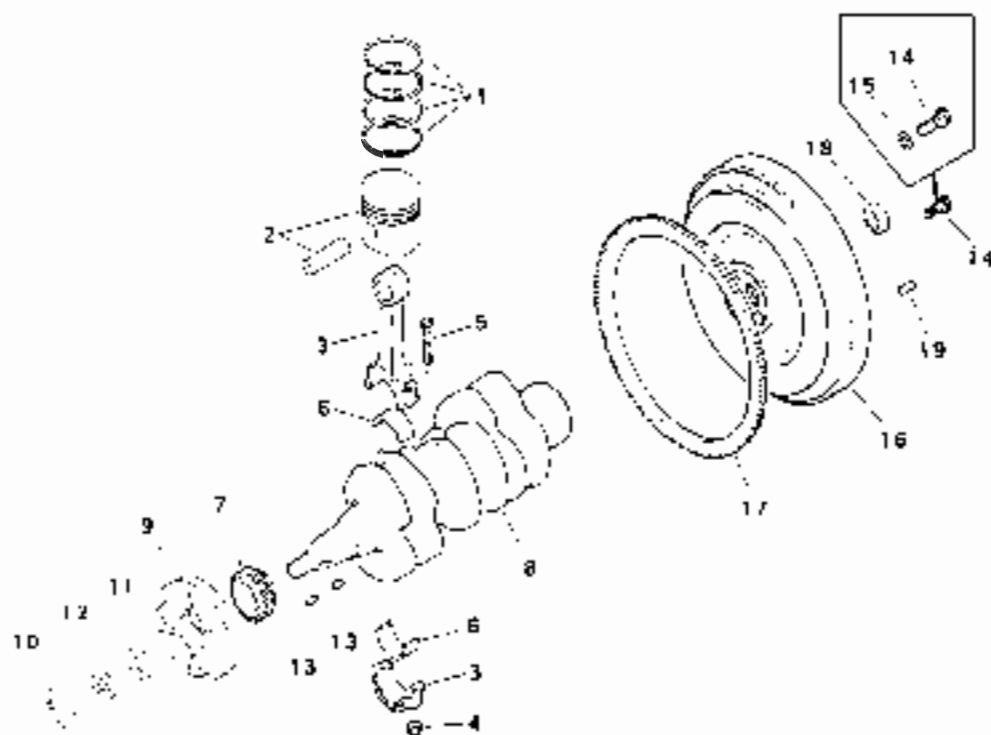

Key No.	Parts No	Parts Name	Qty		Application	Description	Remarks
			ALL	SP			
1	MM433050	RING SET,piston	3		33022~	0.10	
	⊙	RING SFT,piston	3		B 25223~	0.10	MM431201
	⊙	RING SET,piston	3		A	0.10	MM430200
	MM433051	RING SET,piston	3		33023~	0.25 0.5	
	⊙	RING SFT,piston	3		B 25223~	0.25 0.5	MM431202
	⊙	RING SET,piston	3		A	0.25 0.5	MM430201
	MM433052	RING SET,piston	3		33023~	0.50 0.5	
	⊙	RING SET,piston	3		B 25223~	0.50 0.5	MM431203
	⊙	RING SET,piston	3		A	0.50 0.5	MM430202
	MM433053	RING SET,piston	3		33023~	0.75 0.5	
	⊙	RING SET,piston	3		B 25223~	0.75 0.5	MM431204
	⊙	RING SET,piston	3		A	0.75 0.5	MM430203
2	MM433046	PISTON PIN SET	3		33023~	STD	
	MM409520	PISTON PIN SFT	3		D	STD	
	MM433047	PISTON PIN SET	3		33023~	0.25 0.5	
	MM409521	PISTON PIN SFT	3		D	0.25 0.5	
	MM433048	PISTON PIN SET	3		33023~	0.50 0.5	
	MM409522	PISTON PIN SFT	3		D	0.50 0.5	
	MM433049	PISTON PIN SET	3		33023~	0.75 0.5	
	MM409523	PISTON PIN SFT	3		D	0.75 0.5	
3-5	MM409790	CON-ROD ASSY.	3				
3	*	ROD,connecting	3				
4	ML200104	NLT	6				
5	MM402547	SOLET	6				
6	MM409796	BEARING SET	3			STD	
	MM409796	BEARING SFT	3			0.25 J.S	
	MM409797	BEARING SFT	3			0.50 J.S	
	MM409798	BEARING SET	3			0.75 J.S	
7	MM430659	GEAR,crankshaft	1		15317~		
	⊙	GEAR,crankshaft	1		A		MM409510
8	MM409811	CRANKSHAFT	1				
9	MM409821	PLIIEY	1				
10	MF450126	NIJT	1			N'B	
11	MF450010	WASHER	1			N'B	
12	MF450010	WASHER,spring	1			N'B	

FIG.104 MAIN MOVING PARTS

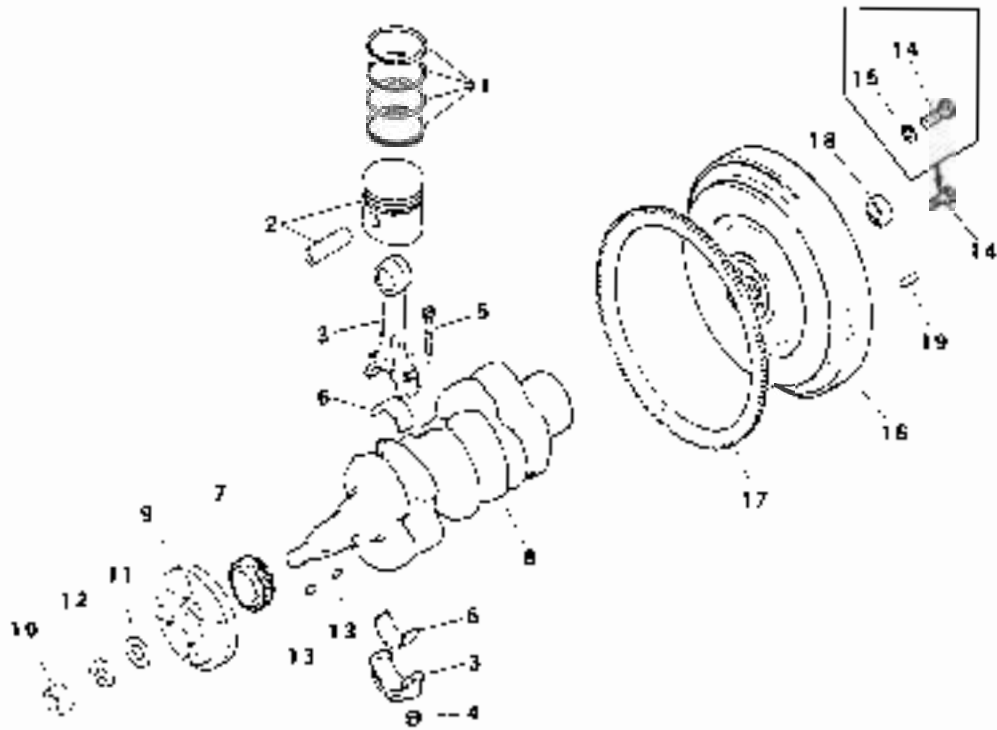

Key No.	Parts No.	Parts Name	Qty			Application	Description	Remarks
			All					
13	MF476215	KEY, woodruff	2					
14	MD952231	BOLT, plate	5			2138		
	○	BOLT, flywheel	5			A		
15	MD014236	WASHER	5				M12	MD002620 Dowel
16, 17	MM412935	FLYWHEEL ASSY.	1					
16	*	FLYWHEEL	1					
17	MD000612	GEAR, ring	1					
18	MD002613	BEARING, ball	1					
19	MF472404	PIN, dowel	3					

FIG.105 TIMING PARTS

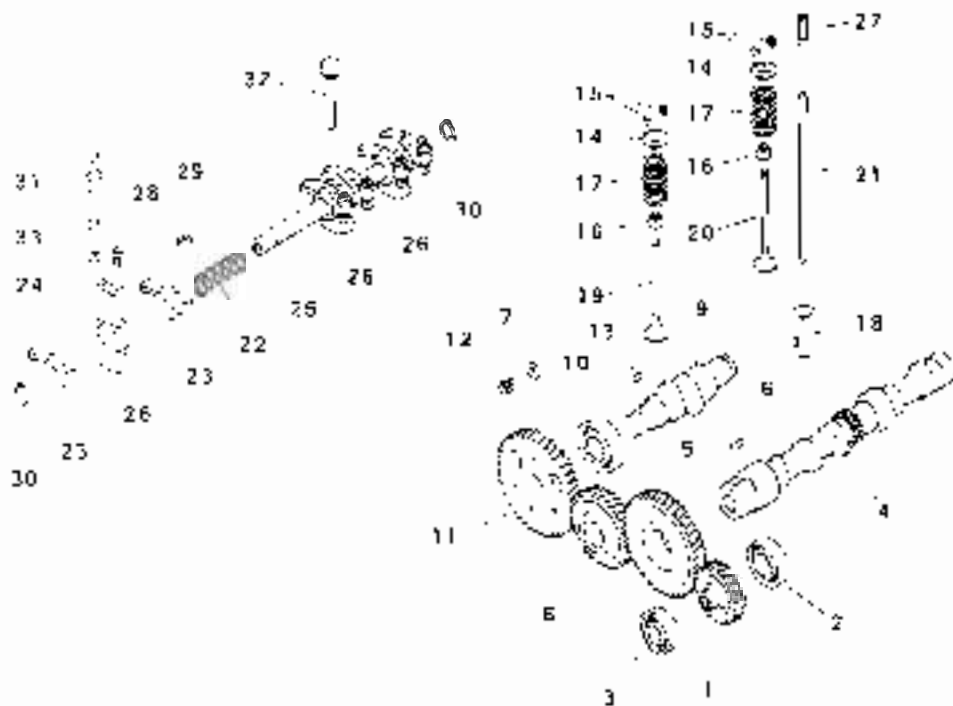

Key No	Parts No	Parts Name	Qty	Unit	Application	Description	Remarks
1	MM407265	GEAR,oil pump	1				
2	MM400127	BEARING	1				
3	MM412517	BEARING	1		24351-		
	○	BEARING	1		4 22519-		K1631160
	○	BEARING	1		4		K1631161
4	MM408909	CAMSHAFT	1				
5	MM406122	GEAR camshaft	1				
6	MF478219	KEY,woodruff	1				
7	MD000126	WASHER	1				
8	MM408903	GEAR ASSY	1				
9	MM408904	SHAFT,pump	1				
10	MD103906	BEARING br	1				
11	MM406696	GEAR pump	1				
12	MF241261	BOLT w/washer	1				
13	MF476019	KEY sunk	1				MBX1E
14	MD015422	RETAINER	5				
15	MD015423	LOCK retainer	7				
16	MD015450	SEAL valve stem	6				
17	MM400381	SPRING valve	5				
18	MM400737	TAPPET	6				
19	MM400450	VALVE, intake	3				
20	MM40845E	VALVE, exhaust	3				
21	MM408920	TOOL, brush	6				
22	MD000963	SPRING, shaft	2				
23	MM405732	ARM rocker	6				
24	MM405745	WASHER seat	2				
25	MM403935	ROCKER SHAFT	1				
26	MM314170	STAY rocker	3				
27	MF201220	SCREW,adjusting	6				
28	MF241226	BOLT,w/washer	2				MBX16
29	MF430720	NUT, jam	6				MBX10
30	MF622010	RING, snap	2				MBX1
31	MM408950	BOLT	2				
32	MF244862	BOLT,w/washer	1				MBX10
33	MF450400	WASHER, spring	2				MBX10

FIG.106 FUEL SUPPLY PARTS

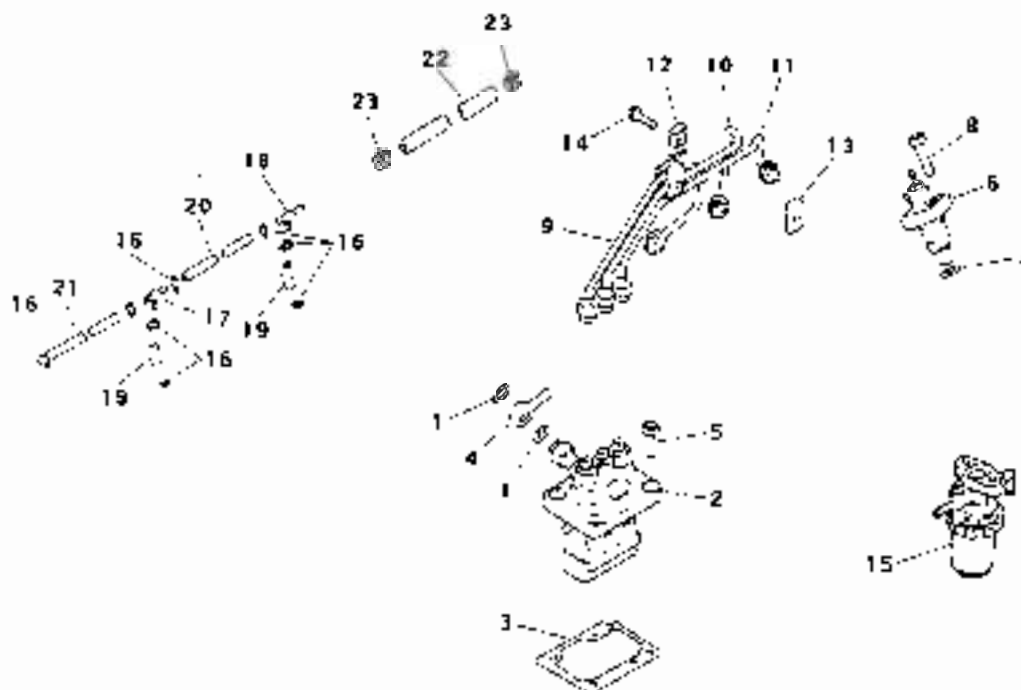

Key No	Parts No	Parts Name	Q'ty				Application	Description	Remarks
			All						
1	MK65112000	WASHER, steel	2				Ø12		
2	MM409847	PUMP ASSY.	1					See Fig 107	
3	MM409831	SP-IM, adjusting	1					15ml NPLS 0.20 10 4.0 3	
4	MM413208	COLLAR, union	1						
5	MF100055	BOLT	4				M6X20		
6	MM401110	NOZZLE HOLDER	3					See Fig 106	
7	K6515430	GASKET, holder	3						
8	MF101260	BOLT	6				M6X32		
9	MM409094	PIPE ASSY NO.1	1						
10	MM409095	PIPE ASSY NO.2	1						
11	MM409096	PIPE ASSY NO.3	1						
12	MM430703	CLAMP A	2			20924 -			
	○	CLAMP A	2			A		MM409095	
13	MM430614	CLAMP B	2			20924 -			
	○	CLAMP B	2			A		MM409096	
14	MF243628	BOLT, w/washer	2				M6X25		
15	MM413142	FUEL FILTER	1						
16-21	MM409103	PIPE ASSY.	1						
16	MM100089	CLAMP, hose	8						
17	MM100089	JOINT	1						
18	MM400886	JOINT	1						
19	MM413132	PIPE, rubber	2						
20	MM413104	PIPE, rubber	1						
21	MM413107	PIPE, rubber	1						
22	MM413205	HOSE, assy	1						
22	MS602063	FUEL HOSE	1						
23	MS660163	CLAMP, rubber	2						

FIG. 107 FUEL INJECTION PUMP

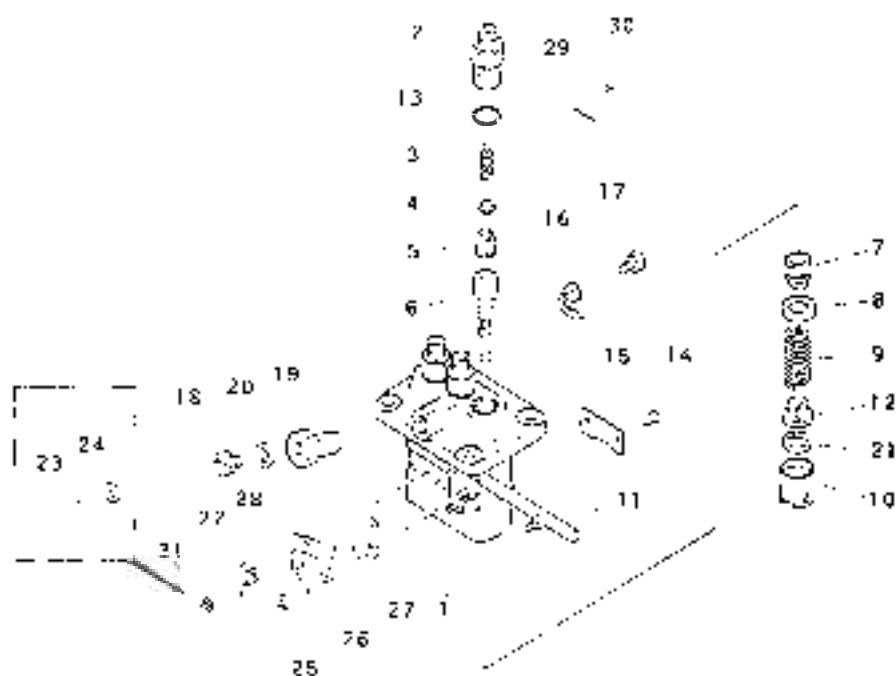

Key No	Parts No	Parts Name	QTY	UNIT	Application	Description	Remarks
30	MM500847	PUMP ASSY.	1				
1	MM501317	POUNCE ASSY.	1				00010-0500
2	MM501507	PLUG valve	2		4	1000	00010-0500
		PLUG valve	2				MM501507
							00010-0500
3	MM501181	SPRING valve	2				00010-0500
4	MM500328	CASSET valve	2				00010-0500
5	MM501048	VALVE SUB ASSY	2				00010-0500
6	MM501220	ELEMENT ASSY	2				00010-0500
7	MM500229	SLIDE valve	1				00010-0500
8	MM501088	SEAT	2				00010-0500
9	MM500300	SPRING plunger	2				00010-0500
10	MM500330	TAPPET ASSY	2				00010-0500
11	MM501311	RACK ASSY	1				00010-0500
12	MM500315	SEAT	2				00010-0500
13	MM500438	O-RING	2				00010-0500
14	MM500231	PLATE	2				00010-0500
15	MM501187	PLATE	1				00010-0500
16	MM501077	PLATE ASSY.	2				00010-0500
17	MM501244	BOLT/washer	2				00010-0500
18	MM501182	SCREW	1				00010-0500
19		SCREW follow	1		4	1000	00010-0500
	MM500403	SCREW follow	1				00010-0500
20	MM500114	WASHER	1				00010-0500
21	MM500293	SHIM plate	0				00010-0500
	MM500329	SHIM plate	0				00010-0500
	MM500310	SHIM plate	0				00010-0500
	MM500311	SHIM plate	0				00010-0500
	MM500312	SHIM plate	0				00010-0500
	MM500314	SHIM plate	0				00010-0500
	MM500315	SHIM plate	0				00010-0500
	MM501249	SHIM plate	0				00010-0500
	MM501384	SHIM plate	AR				00010-0500
	MM501385	SHIM plate	0				00010-0500
22	MM501073	SPRING return	1				00010-0500

FIG. 107 FUEL INJECTION PUMP

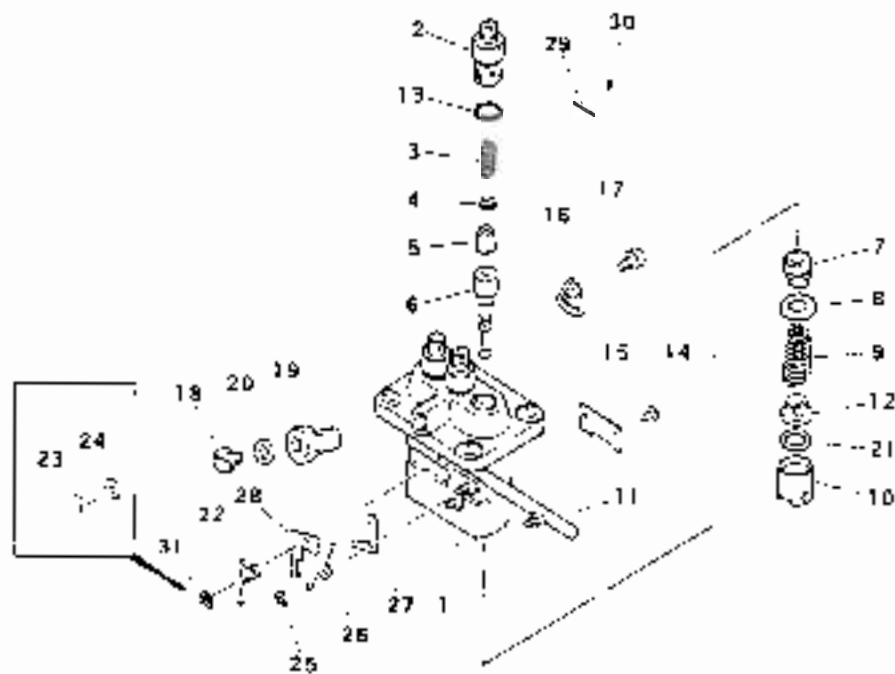

Key No	Parts No	Parts Name	Quantity		Application	Description	Remarks
			A.1	1			
23	MM500431	FIN sp. d	1		2000~		2000~1510 Geared
24	MM500928	WASHER,plate	1		2000~		2450~3010 Geared
25	MM500507	C RING	1				2470~2710
26	MM501256	SPRING	1				2470~2730
77	MM501257	PLATE,(mark:1)	1				29019 2500
	MM501258	PLATE,(mark:2)	1				29019 2510
	MM501259	PLATE,(mark:3)	1				29019 2520
	MM501250	PLATE,(mark:4)	1				29019 2530
	MM501251	PLATE,(mark:5)	1				29019 2540
28	MM501274	STOPPER MARK-75	C				29019 2750
	M/V501574	STOPPER MARK-76	C				29019 2750
	M/V501275	STOPPER MARK-77	D				29019 2750
	M/V501575	STOPPER MARK-78	D				29019 2750
	M/V501386	STOPPER MARK-79	C				29019 2760
	M/V501576	STOPPER MARK-80	C				29019 2760
	MM501387	STOPPER MARK-81	C				29019 2760
	M/V501577	STOPPER MARK-82	C				29019 2760
	M/V501388	STOPPER MARK-83	C				29019 2800
	MM501578	STOPPER MARK-84	C				29019 2810
	M/V501395	STOPPER MARK-85	C				29019 2820
	M/V501579	STOPPER MARK-86	C				29019 2830
	M/V501396	STOPPER MARK-87	C				29019 2830
	M/V501580	STOPPER MARK-88	E				29019 2850
	M/V501397	STOPPER MARK-89	E				29019 2860
23	M/V501425	PLATE,name	1				29019 2850
30	MM500429	R VET	2				24900 2900
31	MM501496	E-RING	1		2000~		29019 2900

FIG. 108 NOZZLE & NOZZLE HOLDER

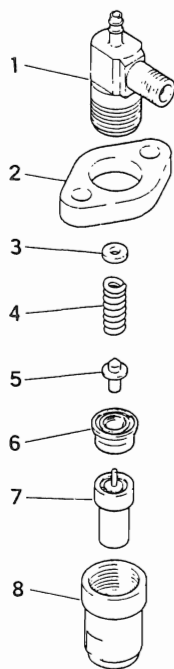

Key No	Parts No	Parts Name	Q' t y				Application	Description	Remarks
			ALL						
1~8	MM401110	NOZZLE HOLDER	3						
1	MM501276	BODY	3					093111-1663	
2	MM501240	FLANGE	3					093266-0100	
3	MM500785	WASHER	C				t= 1.3	093175-0210	
	MM500786	WASHER	C				t= 1.35	093175-0220	
	MM500787	WASHER	C				t= 1.4	093175-0230	
	MM500795	WASHER	C				t= 0.9	093175-0610	
	MM500796	WASHER	C				t= 1.0	093175-0620	
	MM500797	WASHER	C				t= 1.1	093175-0630	
	MM500798	WASHER	C				t= 1.2	093175-0640	
	MM500799	WASHER	C				t= 0.1	093175-0650	
4	MM500136	SPRING,pressure	3					093157-0020	
5	MM500135	PIN,pressure	3					093121-0030	
6	MM500137	PIECE,distance	3					093174-0010	
7	MM300152	NOZZLE ASSY.	3					093400-0010	
8	MM500908	NUT,retaining	3					093164-0800	

FIG. 109 FUEL FILTER

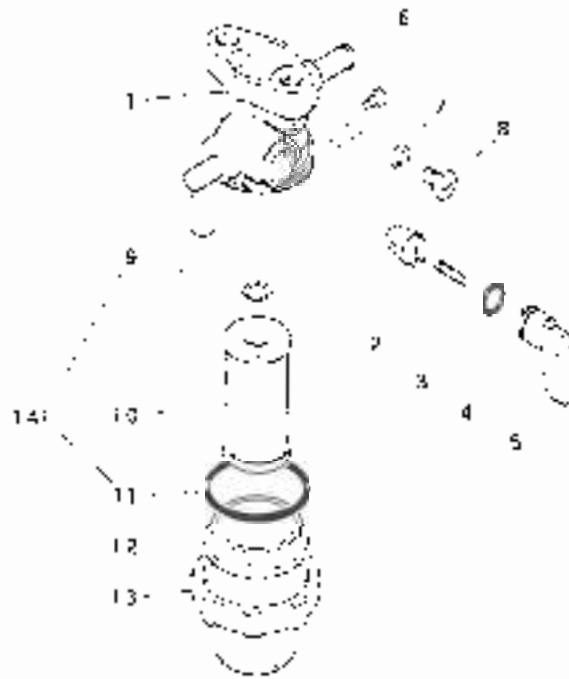

Key No	Parts No	Part Name	QTY	Application	Descriptor	Remarks
1-13	MM413142	FUEL FILTER	1			
1 2	MM40883	BODY SUB ASSY.	1			
2	*	VALVE	1			
3	MM404873	SPRING valve	1			
4	MM404874	O-RING, valve	1			
5	MM404871	LEVER	1			
6	MM404875	SCREW	1			
7	MM404884	PACKING	2			
8	MM404880	SCREW, air vent	2			
9	MM404881	O-RING, element	1			
10	MM404879	ELEMENT	1			
11	MM404873	O-RING	1			
12	MM40883	CLP, filter	1			
13	MM404877	NUT, long	1			
14	MM40882	SERVICE KIT	AS			

FIG. 110 GOVERNOR & CONTROL PARTS

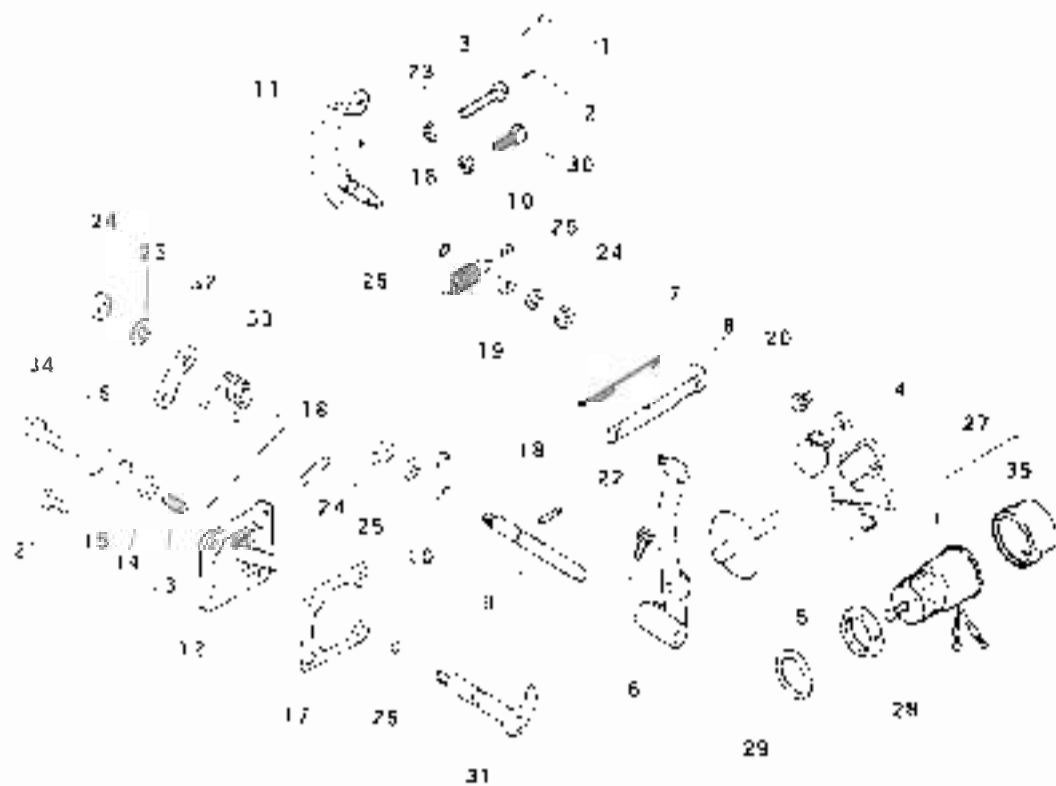

Key No	Part No	Part Name	Alt	Qty	Pos	App	Description	Remarks
1	W63370001	METAL, sealing	1					
2	W633300140	WIRE	1					
3	MV40050	BOLT	1					
4	VM407006	WE GHI ASSY	1			A		VM407006
		WE GPH ASSY	1					
5	VM407010	SHAFT ASSY.	1					
6	VM407028	LEVER ASSY	1					
7	VM409182	SPR No 16 rod	1					
8	VM409181	FOG tie	1					
9	VM407031	SHAFT governor	1					
10	VM407035	LEVER governor	2					
11	VM409231	CONTROLLER	1					
12-15	VM409610	COVER ASSY.	1			C		
	VM409213	COVER ASSY.	1					
12	*	COVER	1					
13	VM409107	SCREW, adjusting	1					
14	VF630091	GASKET	1					
		WASHER seal	1			A		W63120001
15	VM409156	NUT, special	1					
16	VM409139	OSP sealing	1					
17	VM409151	GASKET, cover	1					
18	W6712030	PN, grooved	3			B		W6712030
		PN, grooved	2					
19	VM409136	SPRING	1					
20	M7241222	BOLT, washer	3				MEK 10	
21	M7241226	BOLT, washer	3			C	MEK 10	
	M7241221	BOLT, washer	2				MEK 10	
22	M7244875	BOLT, washer	1				MEK 10	
23	VF470004	NUT	2			B	ME	
		NUT	1				ME	VF470001
24	VF400775	NUT, pin	3			B	ME	VF400726
		NUT, pin	2				ME	VF400726
25	VF450405	WASHER spring	3			B	ME	VF450405
		WASHER spring	2				ME	VF450405
25	V. 520002	O-RING	2			C		

FIG. 110 GOVERNOR & CONTROL PARTS

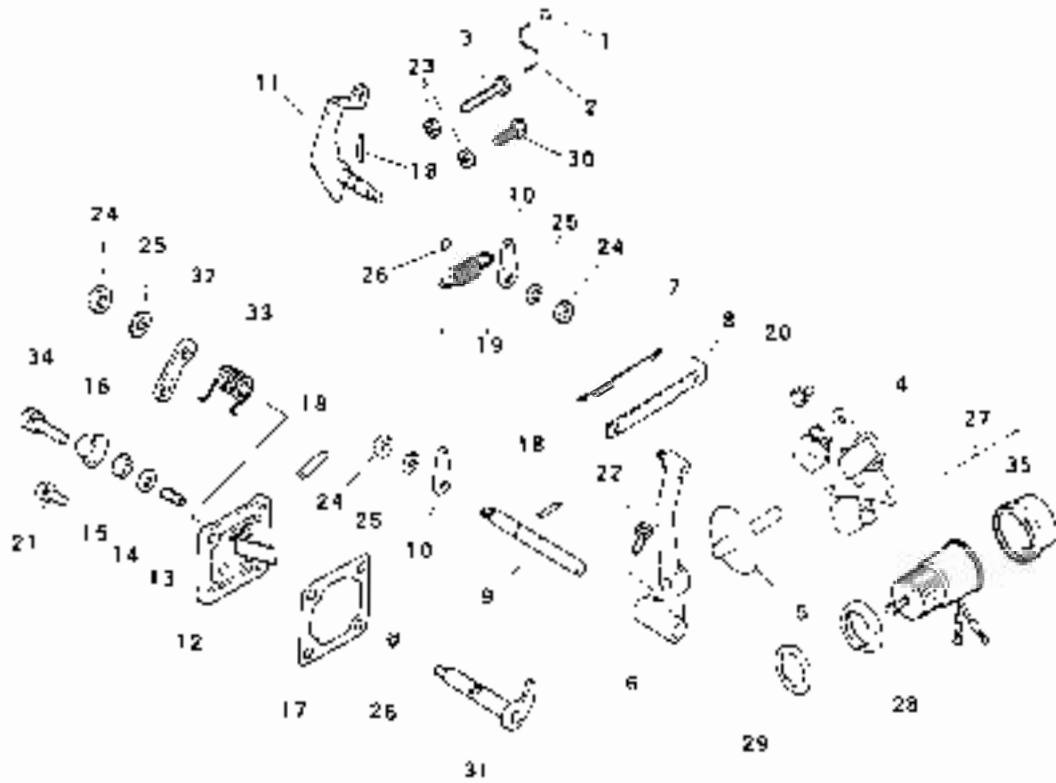

Key No	Parts No	Parts Name	Alt	Qty	Application	Description	Remarks
	Q	O RING			H		M/E2002
27	M/M409670	SOLENOID					
28	M/M409671	NUT					
29	M/FR80042	GASKET					
30	M/M401092	BOLT				230	
31	M/M413360	LEVER ASSY.					42.00
32	M/M409686	LEVER					42.00
33	M/M413352	SPRING return					42.00
34	M/F241231	BOLT w/washer					42.00
35	M/M317093	CA ² gum				M6X33	42.00

FIG.111 OIL PUMP

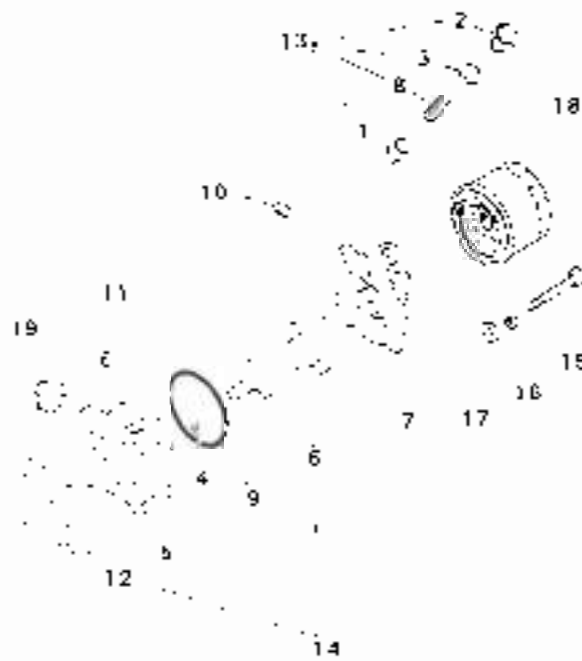

Key No	Parts No	Parts Name	QTY		Application	Description	Remarks
			A	B			
11	MM409371	OIL PUMP ASSY.					
1	MD001402	PISTON relief					
2	MD001404	PISTON					
3	MD005319	GASKET					
4	MM409373	PISTON dowel					
5	MM409244	BODY of pump					
6	MM407175	ROTOR ASSY					
7	MM409372	COVER of pump					
8	MM409204	SPRING relief					
9	MM407145	O-RING					
10	MS6B1121	PLUG taper					FT 114
11	MS6B1120	PLUG taper					FT 116
12	MM407124	GASKET of pump					
13	MM409833	SERVICE KIT	AR				for the main
14	MM409834	SERVICE KIT	AR				for the main
15	MT101269	BOLT	4				MBXSE
16	MT450105	WASHER spring	4				MB
17	MS450035	WASHER	4				MB
18	MM409355	FILTER ASSY					
	G	FILTER ASSY					
19	MM431177	SWITCH ASSY					
	G	SWITCH ASSY					

FIG.112 LUBRICATING PARTS

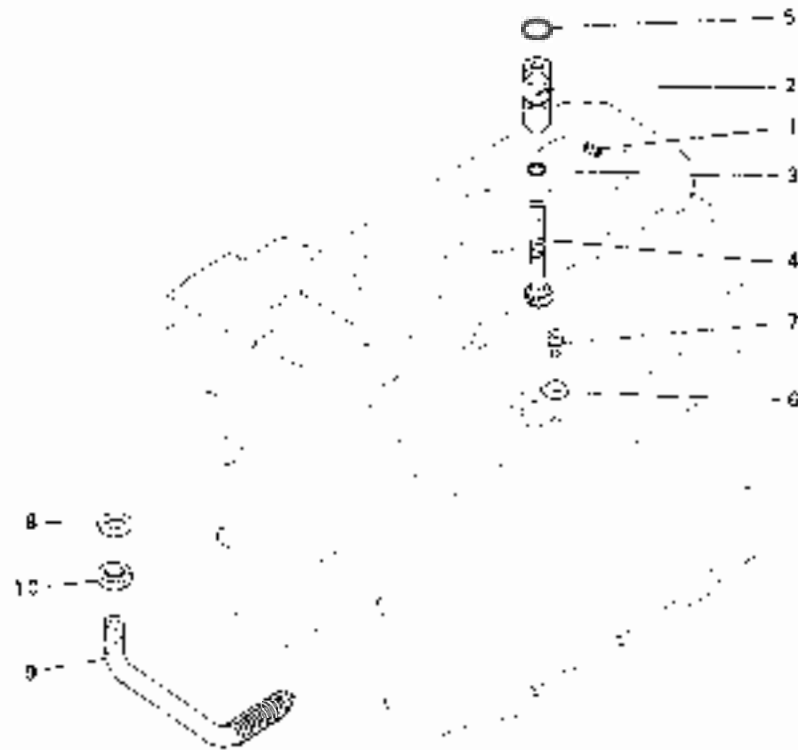

Qty	Parts No	Parts Name	Quantity		Application	Description	Remarks
			ALL				
1-5	M/M430698	DRIVEN UNIT	1		25871-		
	C	DRIVEN UNIT	1		A		W401110
1	M/M472635	PIN, spring	1		A	25871-	M7412626
	C	PIN, spring	1		A		
2	M/M430419	SLEEVE, gear	1		A	25871-	M2001787
	C	SLEEVE, gear	1		A		
3	M/D701788	O-RING	1				38
4	M/M407171	GEAR, driven	1				118
5	M/F520012	O-RING	1				
6	M/D701789	PLATE, locking	1				96A14
7	M/F241274	BOLT w/washer	1				
8	M/F680035	GASKET	1		14611-		
	M/K68114000	WASHER, sea	1		C		214
9, 10	M/M430175	SCREEN ASSY.	1		14611-		
	M/M408716	SCREEN ASSY.	1		C		
	M/F430728	NUT, air	1		14611-		
	M/F430728	NUT, air	1		C		214

FIG.113 COOLING PARTS (1/2)

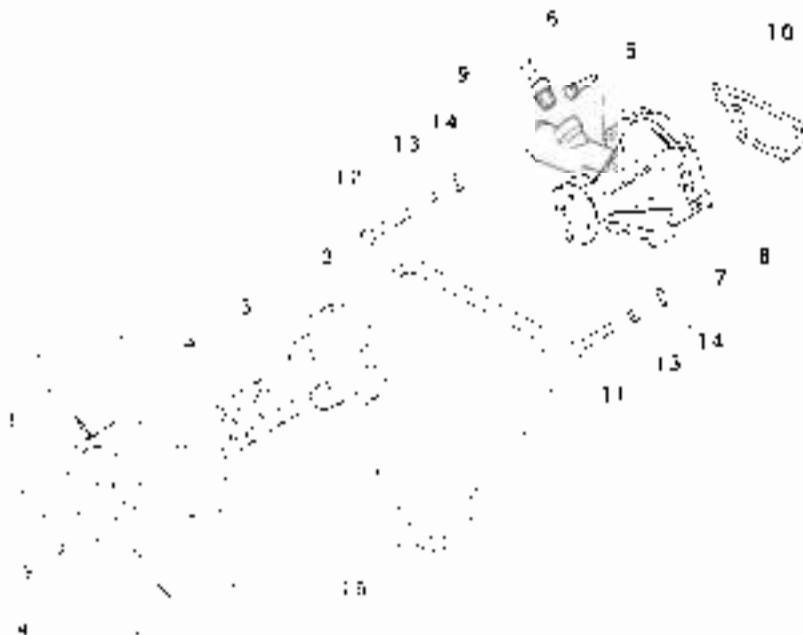

Key No	Parts No	Parts Name	QTY	UNIT	REMARKS	Application Description	Remarks
1	WM434138	FAN cooling	1				
	Q	FAN cooling	1		A	CASKE	WOODRIDGE
2	WM405460	PUMP	1				
3	K9674350	SPACER, fan	2				
4	WM441739	BOLT, w. washer	4			W6417	
5-9	WM409327	PUMP ASSY.	1				
5	Q	PUMP water	1				
6	WM44003	BOLT, w. washer	2			W6403	
7	WM405325	CASKE	1				
8	WM409327	PLATE	1				
9	WM409314	JOINT	1				
10	WM407422	CASKE	1				
11	WM451264	BOLT	3			W6426	
12	WM451267	BOLT	1			W6427	
13	WM450405	WASHER, spring	4			W6	
14	WM450035	WASHER	4			W6	
15	WM001926	BELT fan	1				WY. 0126

FIG.114 COOLING PARTS (2/2)



Key No	Parts No	Parts Name	Qty		Application	Description	Remarks
			ALL				
1	M000551	GASKET	2				
2	M/M409334	FITTING	.				
3	M0001370	THERMSTAT	.				
4	M0009771	FITTING outlet	.				
5	M72412E7	BOLT.w/washer	2			WATER	
E	M/M409311	JOINT water	.				
7, 8	M/M409336	HOSE ASSY.	.				
7	X	HOSE	1				
8	M/S6901E4	CLIP hose	2				
9	M/M409391	SWITCH,thermo	.				
10, 11	M/M413741	HOSE ASSY.	.				
10	X	HOSE	1				
11	M/S6901G3	CLAMP hose	.				

FIG. 115 INTAKE & EXHAUST PARTS

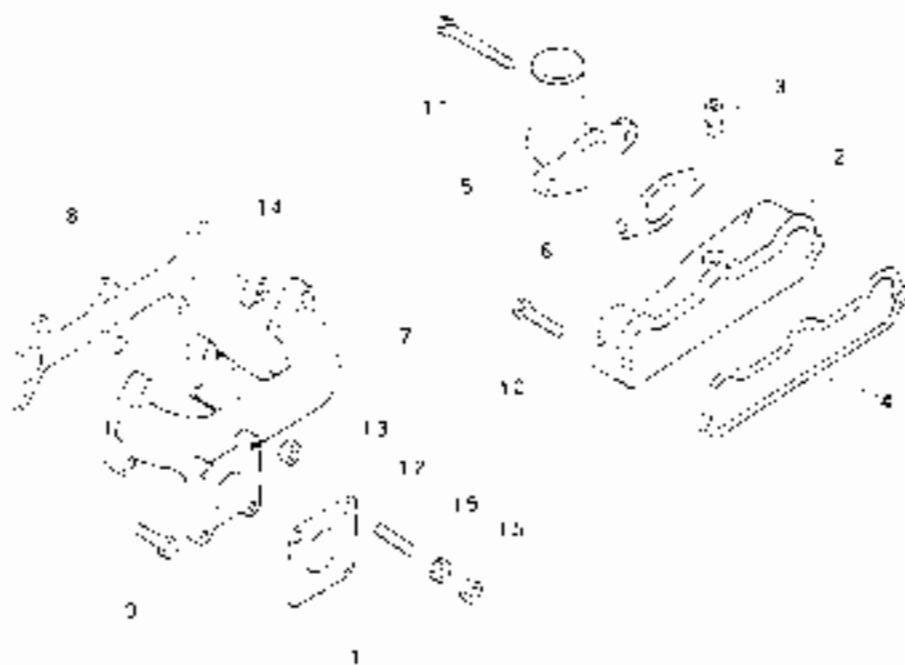

Key No	Part No	Part Name	Qty		Application	Description	Remarks
			Old	New			
1	MM40858	GASKET	.	.			
2,3	MM40854	MANIFOLD ASSY	.	.			
2	*	MANIFOLD intake	.	.			
3	K3644/71	PIPE	.	.			
4	MM40855	GASKET	.	.			
5	MM40856	PIPE, inlet	.	.			
6	MM40856B	GASKET, pipe	.	.			
7	MM41256B	MANIFOLD	.	.			
8	MM40857B	GASKET	.	.			
9	MF101259	DOT	5	.		WAX30	
10	MF241261	BOLT, zinc-plated	.	.		WAX30	
11	MF241267	DOT, zinc-plated	2	.		WAX10	
12	MF401936	STUD	4	.		WAX25	
13	MF402005	NUT	.	.		NA	
14	MY403680	CLAMP, steel	.	.			
15	MG000569	NUT	6	.		NA	

FIG. 116 ELECTRICAL EQUIPMENT

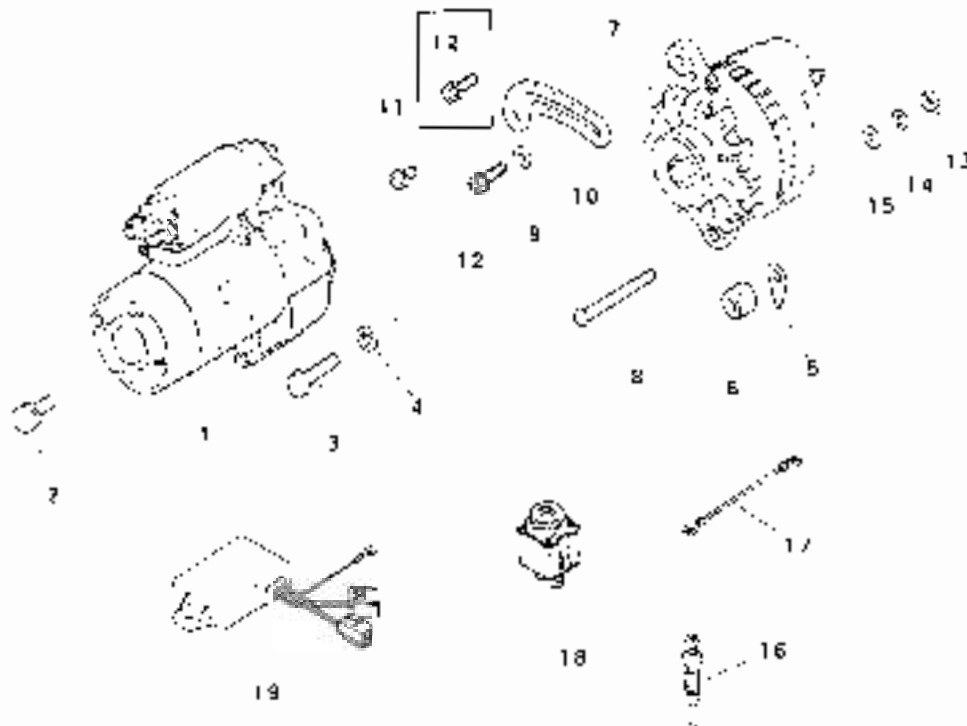

Key No	Parts No	Parts Name	QTY				Application	Description	Remarks
			ALL	1	2	3			
1	MM409410	STARTER ASSY.	1					MM27152101 See Fig 117	
2	MF241282	BOLT, w/washer	1				MEK25		
3	MM409420	BOLT, starter	1				ME10		
4	MF45040E	WASHER, spring	1						
5	MD00'517	SHIM	AP						
6	MV409328	SPACER	1						
7	M30'754E	ALTERNATOR	1					ACC'72014 See Fig 118	
8	M30'752E	BOLT	1				MEK38		
9	M3001521	WASHER	1				MEK38		
		WASHER	1			A	MEK38		
10	MV409463	BRACE	1						
11	MF241251	BOLT, w/washer	1				MEK10		
12	MF140328	BOLT, flange	1						
		BOLT, w/washer	1				A	MEK20	
13	MF430005	NUT	1				ME	ME24'255	
14	MF450405	WASHER, spring	1				ME		
15	MS250335	WASHER	1				ME		
16	MM409510	PLUG, glow	1						
17	MM409511	WIRE, glow plug	1					Y 1141	
18	MM409515	LAMP, glow	1						
19	MM409516	TIMER UNIT	1						

FIG. 117 STARTER



Key No	Parts No	Parts Name	QTY	Application	Descriptor	Remarks
1-22	MM409410	STARTER ASSY.	1			MM409410
1	MD607432	SCREW SET	1			MD1500122
2	MM502368	BRACKET ASSY	1			MD15073522
3	MM502329	LEVER ASSY	1			MD15062221
4	MD602863	SPRING SET	1			MD29510821
5	MM502331	BRACKET ASSY	1			MD150718
6	MM502461	SWITCH ASSY	1	1000		MD21550121
	○	SWITCH ASSY.	1	8		MM502461
7	MM502332	BOLT through	1		1000	MD21550121
8	MM502333	ARMATURE SET	1			MD21550121
9	MM502334	BEARING front	1			MD15073522
10	MM502335	BEARING rear	1			MD15073522
11	MM502347	BOLT through	2			MD15073522
12	MM502355	CLUTCH ASSY.	1			MD15073522
13	MM502356	PINION SET	1			MD15073522
14	MD507415	STOPPER SET	1			MD15073522
15	MD507539	GEAR SET	1			MD15073522
16	MD507540	SHAFT ASSY	1			MD15073522
17	MM502341	GEAR	1			MD15073522
18	MM502342	COVER SET	1			MD15073522
19	MM502387	YOKE ASSY	1			MD15073522
20	MD607420	BRUSH ASSY	1			MD15073522
21	MD602210	SPRING brush	4			MD15073522
22	MM502340	BRACKET rear	1			MD15073522
23	MM409665	BEARING KIT	AR			MD15073522

FIG. 118 ALTERNATOR

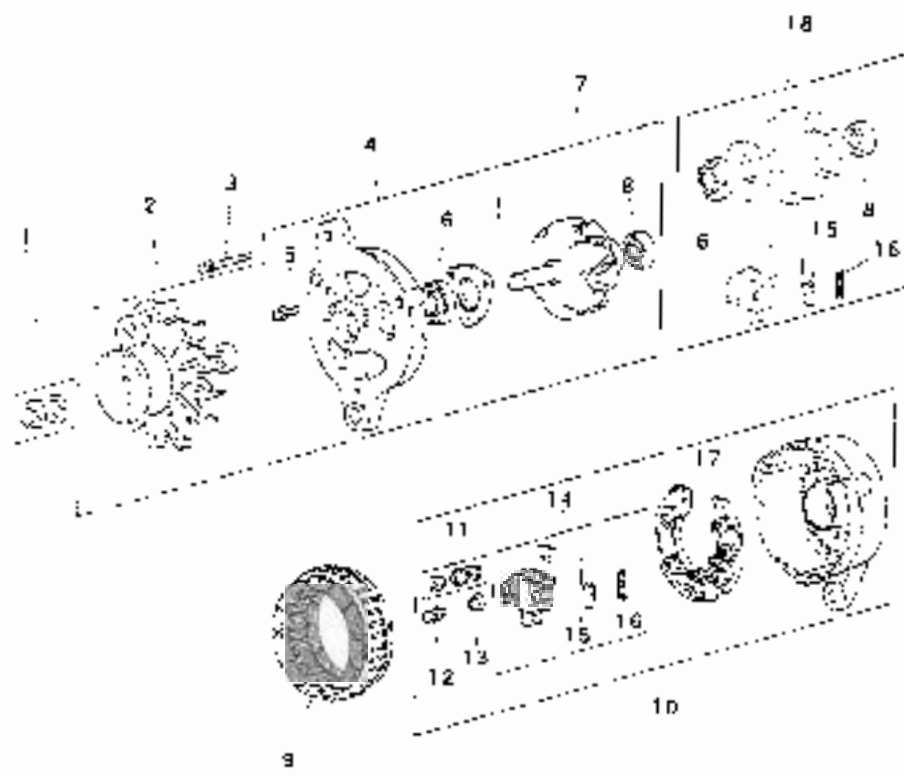

Key No	Parts No	Parts Name	QTY	U	Application	Description	Remarks
1-18	M0017645	ALTERNATOR ASSY	1				4-207304
1	MM502340	NUT SET	1				4579801121
2	M0607170	PULLEY ASSY.	1				4526726870
3	M0607212	SCREW SET	1				44148 2121
4-7	M0607267	BRACKET ASSY	1				4530714070
4	*	FRONT BRACKET	1				
5	M0602930	SCREW SET	1				44 4506111
6	M0602264	BEARING, front	1				5210711170
7	*	HOLDER, bearing	1				
8, 9	MM502296	ROTOR ASSY	1				4630112170
8	*	ROTOR	1				
9	M0602789	BEARING	1				5910716470
10	MM502299	STATOR	1				4330112570
11-18	M0607268	BRACKET ASSY	1				4611721170
11	M0607170	NUT SET	1				4414824071
12	M1350789	SCREW, w/washer	1			M5X10	5014505145
13	M0602826	WELD	1				4111521317
14-15	M0602797	BRUSH ASSY	1				4619024070
14	*	BRUSH HOLDER	1				
15	M0602783	BRUSH	2				4648041570
16	M0602227	SPRING BRUSH	2				4084001170
17	M0607269	RECTIFIER ASSY	1				
18	*	REAR BRACKET	1				441481170
19	MM400897	SERVICE KIT	4,6				441481170

FIG. 119 REPAIR GASKET KIT

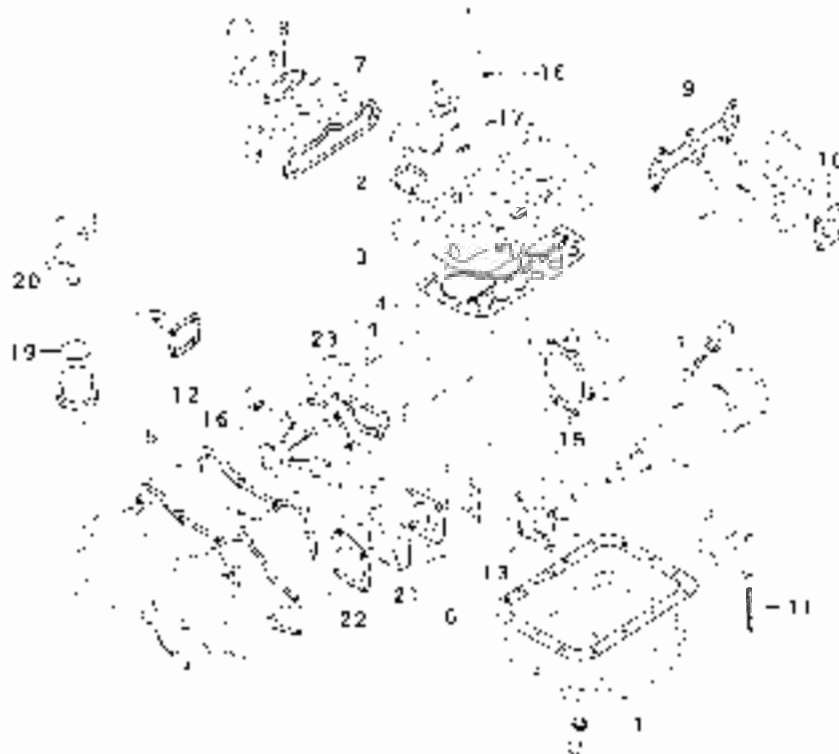

Key No	Parts No	Parts Name	QTY	Application	Description	Remarks
1-23	M/M434004	GASKET KIT	1			
1	M5000312	GASKET (13)	2			
2	M5000551	GASKET	2			
3	M316490	SEAL, sleeve	6			
4	M/M408453	GASKET, cylinder	1			
5	M/M408235	GASKET, gearbox	1			
6	M/M408321	GASKET, oil pan	1			
7	M/M408551	GASKET	1			
8	M/M408566	GASKET, prop	1			
9	M/M408576	GASKET	1			
10	M/M408580	GASKET	1			
11	M/M408226	SPACER	1			
12	M/M409151	GASKET, cover	1			
13	M/M407124	GASKET, oil pump	1			
14	M/M407422	GASKET, pump	1			
15	M/M408205	GASKET, oil seal	1			
16	M/M408220	GASKET, plate	1			
17	EE515430	GASKET, holder	3			
18	M/M432045	GASKET, nozzle	3			
19	M/M404978	O-RING, cup	1			
20	M/M404981	O-RING, element	1			
21	M/M407200	GASKET, cover	1			
22	M/M408235	GASKET, housing	1			

ENGINE

MT250D, 250 (K3H-11A)

FIG. 121 CRANK CASE (1/2)

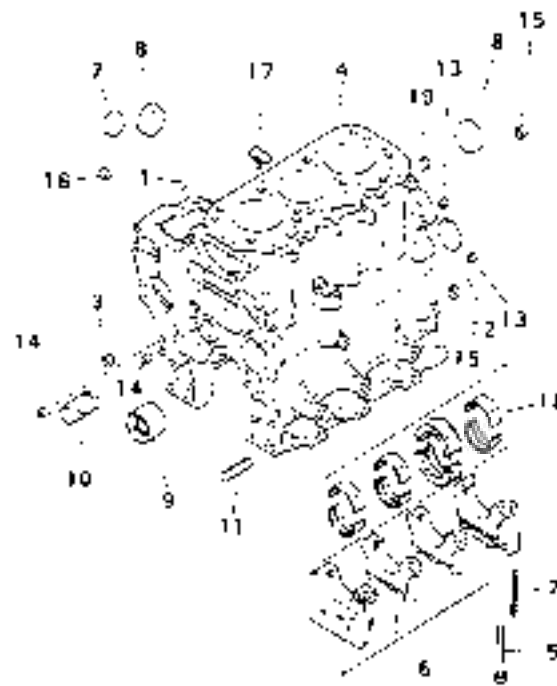

Key No	Parts No	Parts Name	Quantity			Application	Description	Remarks
			Alt	Qty	Unit			
1	MM408645 O	PIN dowel	2			1520-		
2	MM406228	PIN dowel	2			A		RELOCATED
3	MS661122 O	SEAL, side	4					
4-9	MS661122	PLUG, taper	1			4331-		
4-9	MM430186	PLUG, taper	1			A	PT 3-8	MM106248
5	MM406217	BLOCK SUB ASSY.	1					
6	*	BOLT, cap	8					
7	MD000245	CAP ASSY	1					
8	MF85543	PLUG, expansion	1				235	
9	MM406237	CAP, sealing	2				245	
10	MM430113 O	BUUSHING	1					
11	MM402635	SHAFT, idler	1			1000-		
12	MF85512	SHAFT, idler	1			A		MM408153
13	MS471104	STUD	2				714x30	
14	MS471105	PLUG, expansion	1				245	
15	MS471110	BUUSHING, knuck	2				28X9	
16	MS661141 O	BUUSHING, knuck	2				28X13	
17	MM408260	BUUSHING, knuck	2				612AE	
18	MS661141 O	PLUG, taper	1			4240-		
19	MM408260	PLUG, taper	1			A	PT 1-4	MS661121
18	MM406254	JOINT, drain	1					
18	MM406255	BEARING SET	1				STD	
18	MM406255	BEARING SET	1				0.25 J/S	
18	MM406255	BEARING SET	1				0.50 J/S	
18	MM406257	BEARING SET	1				0.75 J/S	
19	MD040338 O	PLUG, taper	1			4831-		MM104338
19	MD040338 O	PLUG, taper	1			A		

FIG. 122 CRANK CASE (2/2)

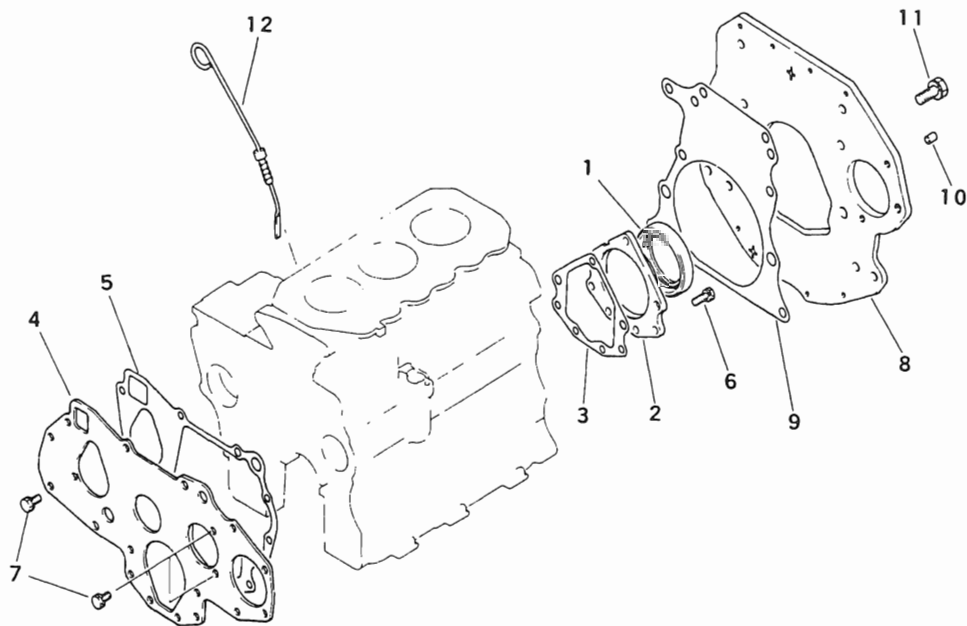

Key No	Parts No	Parts Name	Q' t y				P	Application	Description	Remarks
			ALL							
1	MM406242	SEAL,oil	1							
2	MM412662	CASE,oil seal	1							
3	MM406241	GASKET,oil seal	1							
4	MM406264	PLATE,front	1							
5	MM406265	GASKET	1							
6	MF240054	BOLT,w/washer	7					M8X22		
7	MF240051	BOLT,w/washer	3					M8X16		
8	MM412685	PLATE,rear	1							
9	MM412700	GASKET	1							
10	MM408240	PIN,knock	2					φ8X10		
11	MF241308	BOLT,w/washer	6					M12X28		
12	MM412643	GAUGE	1							

FIG. 123 OIL PAN & GEAR CASE

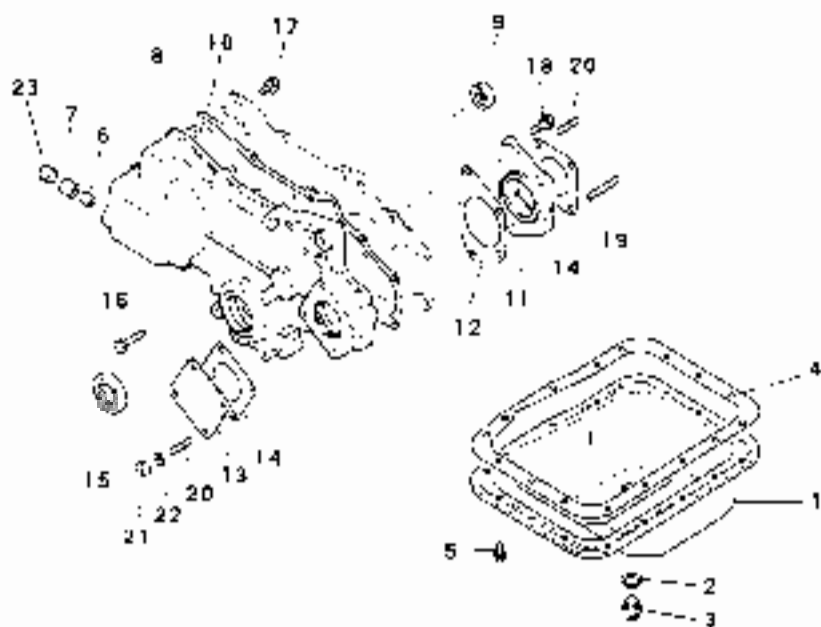

Key No	Parts No	Parts Name	Qty				Application	Description	Remarks
			Alt.						
1-3	MM112625	OIL PAN ASSY	1						
1	*	PAN oil	1						
2	MCC00312	GASKET	1				oil		
3	MCC00318	PLUG, oil drain	1						
4	MM112651	GASKET, oil pan	1						
5	MF240051	BOLT, w/washer	16				W11-6		
6	MM408420	BEARING, needle	1						
7	MM408421	BEARING, needle	1						
8	MM408382	CASE, gear	1						
9	MM408718	PLUG, thrust	1						
10	MM408416	GASKET	1						
11	MM407260	HOUSING	1						
12	MM407261	GASKET, housing	1						
13	MM401205	COVER, shaft	1						
14	MM401206	GASKET, cover	2						
15	MCC08762	SEAL, oil	1				4541		
	⊙	SEAL, oil	1				A	K5-11735C	
16	MF100064	BOLT	10				W11-15		
17	MF240051	BOLT, w/washer	2				W11-8		
18	MF241255	BOLT, w/washer	2				W11-25		
19	MS401434	STUD	2				W11-12		
20	MF402565	STUD	6				W11-29		
21	MF430005	NUT	4				W3		
22	MF450405	WASHER, spring	4				W3		
23	MS661123	PLUG, taper	1				W11-12		

FIG. 124 CYLINDER HEAD

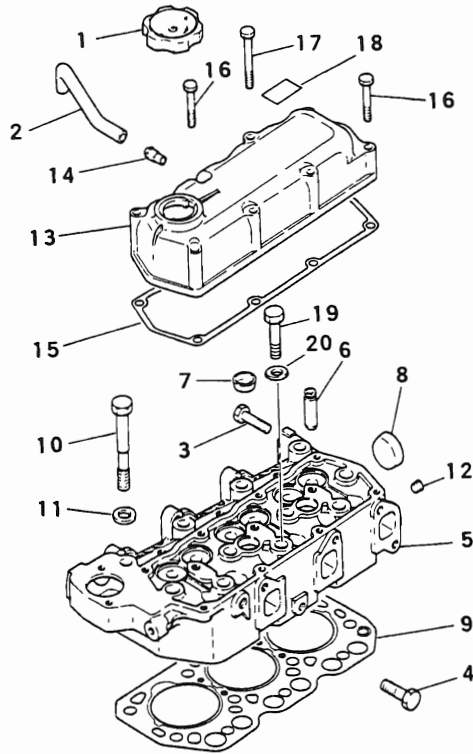

Key No	Parts No	Parts Name	Q'ty				F/P	Application	Description	Remarks
			ALL							
1	MDO08784	CAP,oil filter	1							
2	MM408537	PIPE,breather	1							
3	MF106091	BOLT	1					M10X40		
4	MF101316	BOLT	1				1630~	M12X40		
	○	BOLT	1				A	M12X40	MF106116	
5-8	MM430168	CYLINDER HEAD	1							
	MM412522	CYLINDER HEAD	1				D	1660~		
5	*	HEAD,cylinder	1							
6	MM412561	GUIDE, valve	6							
7	MF665538	CAP,sealing	2					φ25		
8	MDO00427	PLUG,expantion	1					φ40		
9	MM412540	GASKET,head	1							
10	K9612300	BOLT	7					M14X104		
11	K7510250	WASHER	8							
12	MS661140	PLUG,taper	1				A	4240~	PT = 1/8	
	○	PLUG,taper	1						PT = 1/8	
13, 14	MM412573	ROCKER COVER	1						MS661120	
13	*	COVER,rocker	1							
14	K9644171	PIPE	1							
15	MM412572	GASKET,cover	1							
16	MF100065	BOLT	3					M8X50		
17	MF100069	BOLT	5					M8X70		
18	MM412720	LABEL,model	1					M25	(K3H-11A)	
19	MM430156	BOLT	3							
20	MDO20733	WASHER	3							

FIG.125 MAIN MOVING PARTS

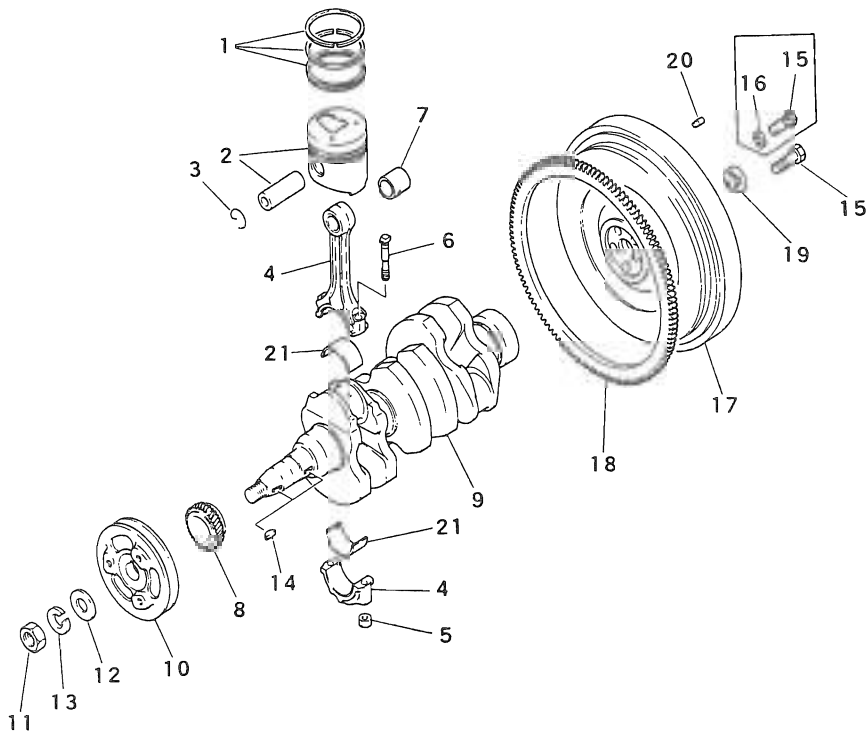

Key No	Parts No	Parts Name	Q' t y				P	Application	Description	Remarks
			ALL							
1	MM433921	PISTON RING SET	3				5587~	S.T.D		
	MM412980	PISTON RING SET	3				D	S.T.D		
	MM433922	PISTON RING SET	3				5587~	0.25 O.S		
	MM412981	PISTON RING SET	3				D	0.25 O.S		
	MM433923	PISTON RING SET	3				5587~	0.50 O.S		
	MM412982	PISTON RING SET	3				D	0.50 O.S		
	MM433924	PISTON RING SET	3				5587~	0.75 O.S		
	MM412983	PISTON RING SET	3				D	0.75 O.S		
2	MM432509	PISTON PIN SET	3				5587~	S.T.D		
	MM412784	PISTON PIN SET	3				D	S.T.D		
	MM433905	PISTON PIN SET	3				5587~	0.25 O.S		
	MM412750	PISTON PIN SET	3				D	0.25 O.S		
	MM433906	PISTON PIN SET	3				5587~	0.50 O.S		
	MM412751	PISTON PIN SET	3				D	0.50 O.S		
	MM433907	PISTON PIN SET	3				5587~	0.75 O.S		
	MM412752	PISTON PIN SET	3				D	0.75 O.S		
3	K8221251	CLIP, piston pin	6							
4-7	MM412860	CON-ROD ASSY.	3							
5	MD006704	NUT	6							
6	MM412869	BOLT	6							
7	MM330347	BEARING	3							
8	MM430859	GEAR	1				1750~			
	○	GEAR	1				A		MM406570	
9	MM412886	CRANKSHAFT	1							
10	MM406578	PULLEY	1							
11	MF430731	NUT	1					M20		
12	MF450011	WASHER	1					M20		
13	MF450411	WASHER, spring	1					M20		
14	MF476215	KEY, woodruff	2							
15	MD952231	BOLT	5				1660~	5X19		
	○	BOLT, flywheel	5				A		MD002620	
16	MD014236	WASHER, spring	5				~1659	M12	Deleted	
17, 18	MM412935	FLYWHEEL ASSY.	1							
17	*	FLYWHEEL	1							
18	MD000612	GEAR, ring	1							

FIG.125 MAIN MOVING PARTS

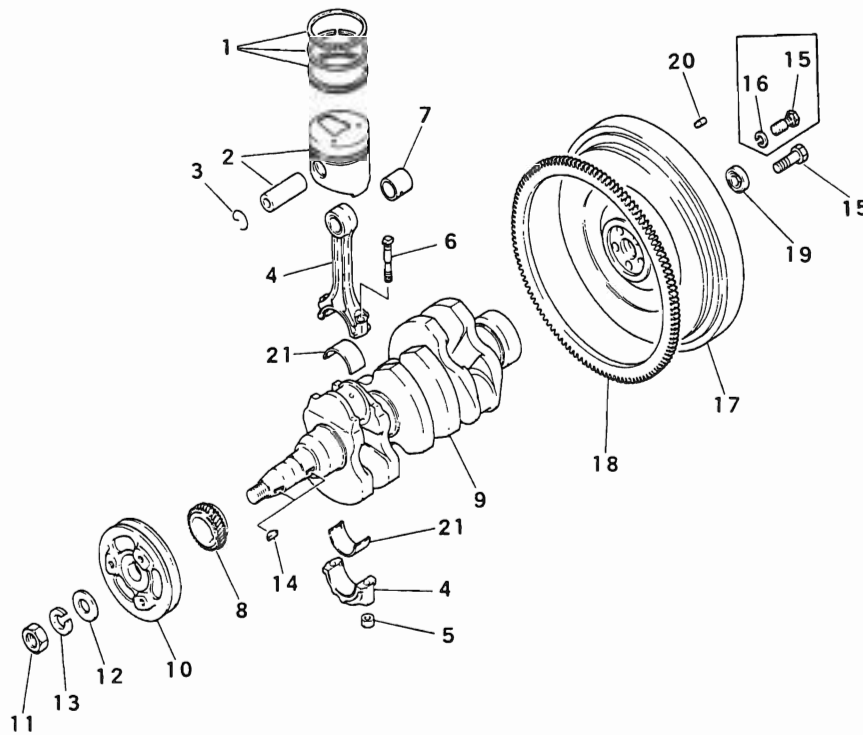

Key No	Parts No	Parts Name	Q' t y				P	Application	Description	Remarks
			ALL							
19	MD002613	BEARING	1							
20	MF472404	PIN,dowel	3							
21	MM400650	BEARING SET	3					S.T.D		
	MM400651	BEARING SET	3					0.25 O.S		
	MM400652	BEARING SET	3					0.50 U.S		
	MM400653	BEARING SET	3					0.75 U.S		

FIG.126 VALVE MECHANISM

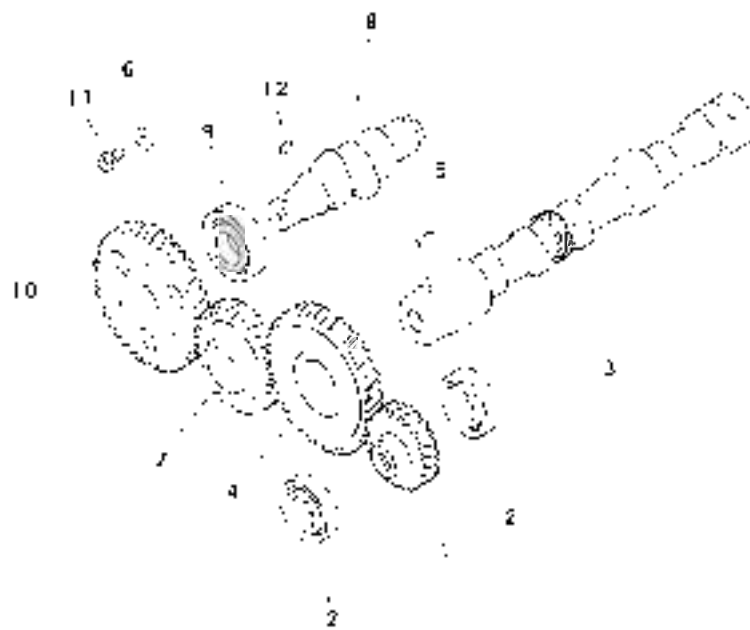

Key No	Parts No	Parts Name	Qty	App. Section	Description	Remarks
1	MM40524	GEAR at pump	1			
2	MD712517	BEARING,ba	2	203-		
	○	BEARING,ba	2	A 204-		CONTINUING
	○	BEARING,ba	2	A		CONTINUING
3	MM413032	CAMSHAFT	1			
4	MM406722	GEAR camshaft	1			
5	MF476215	KEY woodruff	1			EX-11
6	MD000425	WASHER	1			
7	MM406661	IDLER GEAR ASSY	1			
8	MM408964	CAMSHAFT, pump	1			
9	MD703656	BEARING	1			
10	MM406589	GEAR pump	1			
11	MF241251	BOLT w/washer	1			WASHER
12	MF476018	KEY screw	1			EX-2

FIG.127 TIMING PARTS

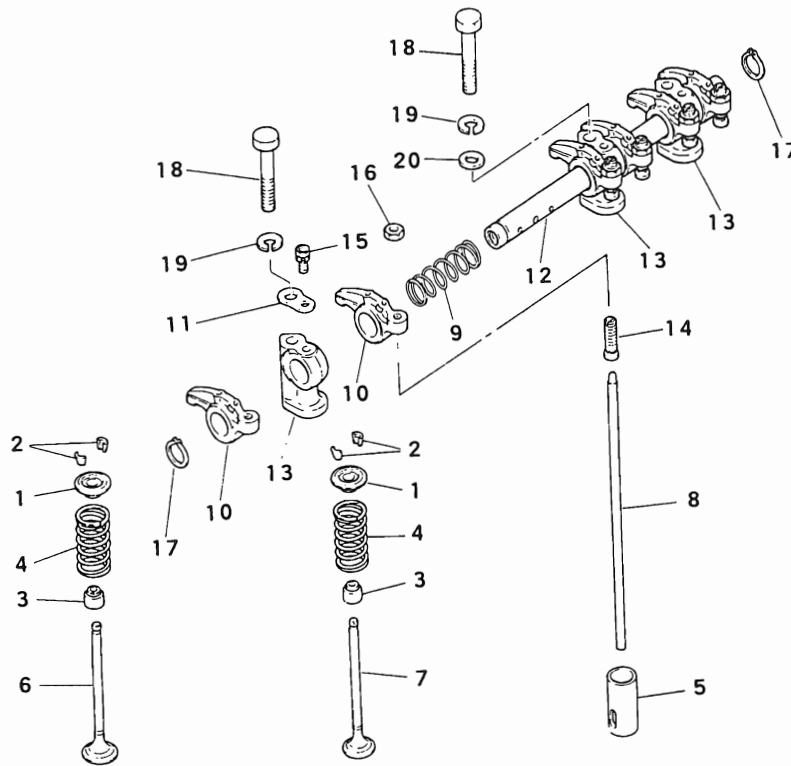

Key No	Parts No	Parts Name	Q'ty					R/P	Application	Description	Remarks
			ALL								
1	MD008761	RETAINER	6					2492~			
	MD005505	RETAINER	6					~2491			
2	MD008760	LOCK,retainer	12					2492~			
	MD000506	LOCK,retainer	12					~2491			
3	MM413060	SEAL, valve stem	6								
4	MD000500	SPRING, valve	6								
5	MM402737	TAPPET	6								
6	MM413050	VALVE,intake	3								
7	MM413051	VALVE,exhaust	3								
8	K7331230	ROD,push	6								
9	MD000963	SPRING,shaft	2								
10	MM406732	ARM,rocker	6								
11	MM406745	WASHER,seat	2								
12	MM413040	ROCKER SHAFT	1								
13	MM413043	STAT,rocker	3								
14	K7231220	SCREW,adjusting	6								
15	MF241225	BOLT,w/washer	2						M6X16		
16	MF430726	NUT,jam	6						M10		
17	MF522010	RING,snap	2						φ19		
18	MF101296	BOLT	3						M10X65		
19	MF450406	WASHER,spring	3						M10		
20	MF450006	WASHER	1						M10		

FIG.128 FUEL SUPPLY PARTS

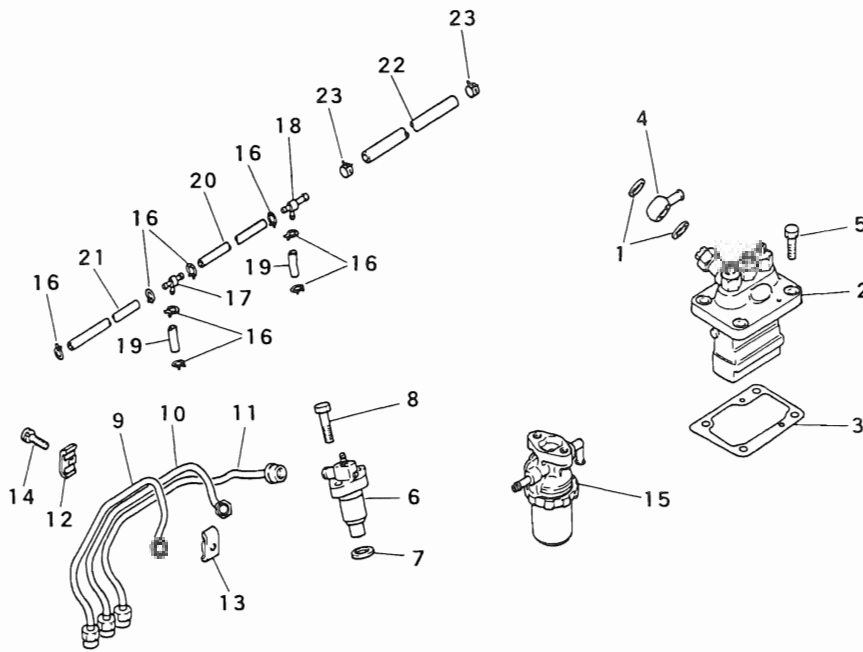

Key No	Parts No	Parts Name	Q'ty				P/P	Application	Description	Remarks
			ALL							
1	MK66114000	WASHER, seal	2					φ14		
2	MM413235	PUMP ASSY.	1				1530~			
	○	PUMP ASSY.	1				A		MM413225 See Fig 129	
3	MM409891	SHIM SET	AR						1Set 4PCS t=0 2.0 3.0 4.0 8	
4	MM409125	COLLAR, union	1							
5	MF100055	BOLT	4					M8X20		
6	MM402974	NOZZLE HOLDER	3						See Fig 130	
7	K6515430	GASKET, holder	3							
8	MF101260	BOLT	6					M8X32		
9	MM430300	PIPE ASSY, no.1	1				1660~			
	○	PIPE ASSY, no.1	1				A		MM406960	
10	MM430302	PIPE ASSY, no.2	1				1660~			
	○	PIPE ASSY, no.2	1				A		MM406962	
11	MM430304	PIPE ASSY, no.3	1				1660~			
	○	PIPE ASSY, no.3	1				A		MM406964	
12	MM430703	CLAMP A	2				2607~			
	○	CLAMP A	2				A		MM400955	
13	MM430614	CLAMP B	2				2607~			
	○	CLAMP B	2				A		MM400956	
14	MF243628	BOLT, w/washer	2					M6X25		
15	MM413142	FUEL FILTER	1						See Fig 131	
16-21	MM413202	FUEL PIPE ASSY.	1							
16	MM100089	CLAMP, hose	8							
17	MM100088	JOINT	1							
18	MM400886	JOINT	1							
19	MM413101	HOSE	2					φ5X25		
20	MM413105	HOSE	1					φ5X90		
21	MM413108	HOSE	1					φ5X115		
22, 23	MM413205	FUEL HOSE ASSY	1							
22	*	HOSE, fuel	1					φ6X360		
23	MS660163	CLIP, hose	2					φ11.6		

FIG.129 FUEL INJECTION PUMP

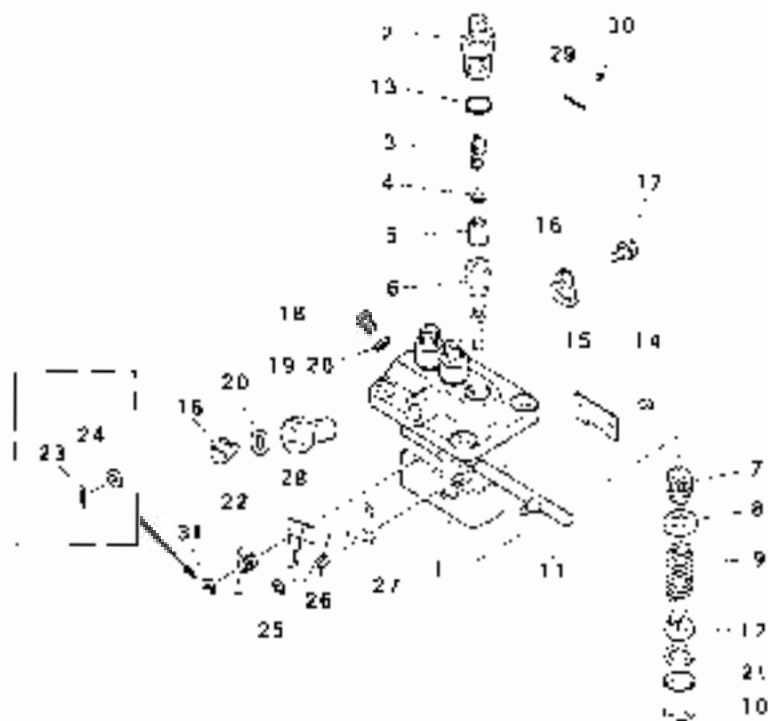

Key No	Parts No	Parts Name	Q'ty		Application	Description	Remarks
			ALL	H.P.			
1-3	MM413235	PUMP ASSY.	1		1532-		
	C	PUMP ASSY.	1		A		MM413235
	MM501404	HOUSING ASSY	1				04010-0270
2	MM501507	HOLDER, valve	3		1532-		04011-0270
	Q	HOLDER, valve	3		A		04012-0270
							04013-0270
3	MM501161	SPRING, valve	3				04016-0240
4	MM500335	GASLET, valve	3				04017-0201
5	MM501075	VALVE SUB ASSY.	3				04018-0100
6	MM501211	ELEMENT ASSY	3				04019-0101
7	MM500229	SCREW, plunger	3				04021-0210
8	MM501038	SEAT	3				04023-0202
9	MM500360	SPRING, plunger	3				04024-0170
10	MM500230	TAPPET ASSY.	3				04025-0110
11	MM501311	BACK ASSY	1				04026-0410
12	MM500316	SEAT	3				04027-0200
13	MM500438	O-RING	3				04028-0210
14	MM500231	PIB	3				04029-0200
15	MM501162	PLATE	1				04030-0140
16	MM501077	PLATE ASSY.	2				04031-0217
17	MM501244	BOLT, w/washer	2				04032-0200
18	MM501045	SCREW	2				04034-0100
	Q	SCREW	1		1107-		04035-0100
					A		04036-0100
19	MM500442	SCREW, follow	1				04037-0210
20	MM500114	WASHER	2				04038-0200
21	MM500299	SHIM, plate	C			0.0	04039-0210
	MM500309	SHIM, plate	C			0.2	04040-0210
	MM500310	SHIM, plate	C			0.3	04041-0210
	MM500311	SHIM, plate	C			0.4	04042-0210
	MM500312	SHIM, plate	C			0.5	04043-0210
	MM500314	SHIM, plate	C			0.25	04044-0100
	MM500315	SHIM, plate	C			0.35	04045-0100
	MM501246	SHIM, plate	C			0.45	04046-0210
	MM501364	SHIM, plate	C			0.55	04047-0100

FIG. 129 FUEL INJECTION PUMP

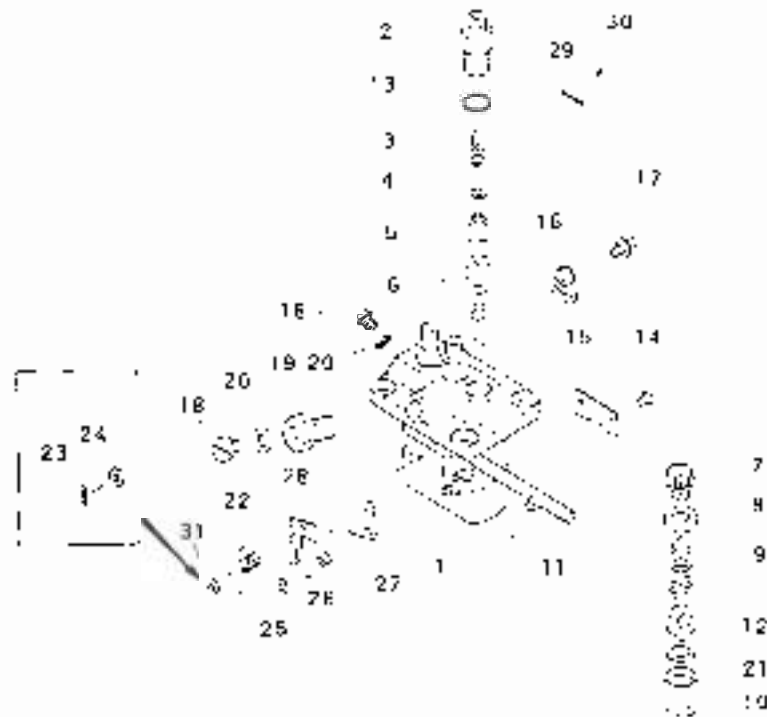

Key No.	Parts No.	Parts Name	QTY	UNIT	Application	Description	Remarks
22	MM501365	SH PLATE	1		6-65	00011 0-04	
	MM501247	SPRING return	1		1-10	00054 0-00	
	MM501429	SPRING return	1		00054 0-00		
23	MM500431	P.N. split	1		3-65	00020 1-00	
24	MM500378	WASHER plate	1		3-65	00021 0-00	
25	MM500507	E-RING	1			00094 0-00	
26	MM501312	SPRING	1		1-10	00054 0-00	
	MM501256	SPRING	1			00054 0-00	
27	MM501497	FLATE set	1			00014 0-00	
	MM501498	FLATE set	1			00014 0-00	
	MM501499	FLATE set	1			00014 0-00	
	MM501500	FLATE set	1			00014 0-00	
	MM501501	FLATE set	1			00014 0-00	
28	MM501559	STOPPER VARI-65	1			00014 0-00	
	MM501270	STOPPER VARI-67	1			00014 0-00	
	MM501570	STOPPER VARI-69	1			00014 0-00	
	MM501271	STOPPER VARI-69	1			00014 0-00	
	MM501571	STOPPER VARI-70	1			00014 0-00	
	MM501272	STOPPER VARI-71	1			00014 0-00	
	MM501572	STOPPER VARI-72	1			00014 0-00	
	MM501273	STOPPER VARI-73	1			00014 0-00	
	MM501573	STOPPER VARI-74	1			00014 0-00	
	MM501274	STOPPER VARI-75	1			00014 0-00	
	MM501574	STOPPER VARI-75	1			00014 0-00	
	MM501275	STOPPER VARI-77	1			00014 0-00	
	MM501575	STOPPER VARI-78	1			00014 0-00	
	MM501396	STOPPER VARI-79	1			00014 0-00	
	MM501576	STOPPER VARI-80	1			00014 0-00	
29	MM501437	FLATE name	1			00060 0-00	
30	MM500429	RIVET	2			00014 0-00	
31	MM501498	E-RING	1		1-10	00094 0-00	

FIG.130 NOZZLE & NOZZLE HOLDER

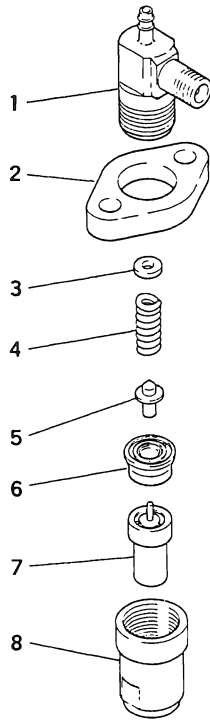

Key No	Parts No	Parts Name	Q' t y					P P	Application	Description	Remarks
			ALL								
1~8	MM402974	NOZZLE HOLDER	3							093500-2300	
1	MM501405	BODY	3							093111-2300	
2	MM501240	FLANGE	3							093266-0100	
3	MM501411	WASHER	C						t = 1.8	093175-0980	
	MM501412	WASHER	C						t = 1.85	093175-0990	
	MM501413	WASHER	C						t = 1.9	093175-1000	
	MM501414	WASHER	C						t = 1.95	093175-1010	
	MM501415	WASHER	C						t = 2.0	093175-2100	
	MM501416	WASHER	C						t = 2.05	093175-2110	
	MM501417	WASHER	C						t = 2.1	093175-2120	
	MM501418	WASHER	C						t = 2.15	093175-2130	
	MM501419	WASHER	C						t = 2.2	093175-2140	
	MM501420	WASHER	C						t = 2.25	093175-2150	
	MM501421	WASHER	C						t = 2.3	093175-2160	
	MM501422	WASHER	C						t = 2.35	093175-2170	
4	MM500136	SPRING,pressure	3							093127-0020	
5	MM500135	PIN,pressure	3							093121-0030	
6	MM500137	PIECE,distance	3							093174-0010	
7	MM300152	NOZZLE ASSY.	3							093400-0010	
8	MM500908	NUT,retaining	3							093164-0800	

FIG.131 FUEL FILTER

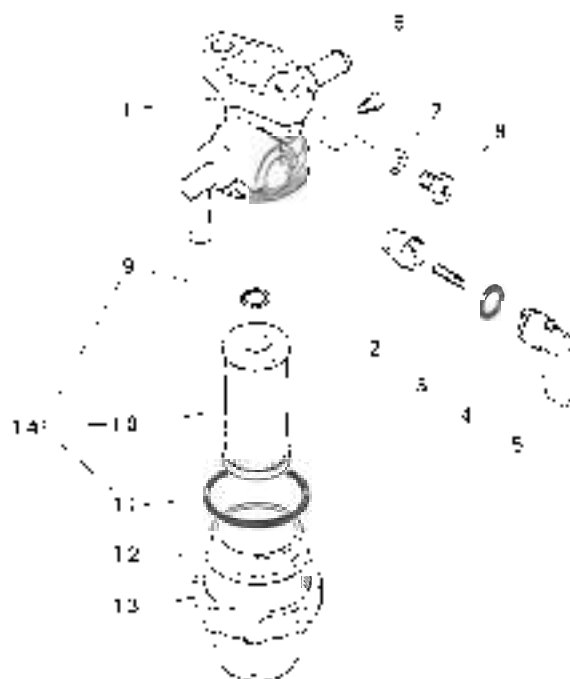

Key No	Parts No	Parts Name	Quantity	Application	Description	Remarks
1-13	MM413142	FUEL FILTER	1			
1.2	MM406893	BODY SUB ASSY.	1			
2	X	VALVE	1			
3	MM404873	SPRING valve	1			
4	MM404874	C RING, valve	1			
5	MM404871	LEVER	1			
6	MM404875	SCREW	1			
7	MM404884	PACKING	2			
8	MM404880	SCREW, air vent	2			
9	MM404881	C-RING	1			
10	MM404879	ELEMENT	1			
11	MM404878	C-RING, cap	1			
12	MM406889	CLF, filter	1			
13	MM404877	NUT, ring	1			
14	MM409892	SERVICE KIT	AS			

FIG. 132 GOVERNOR & CONTROL PARTS (1/2)

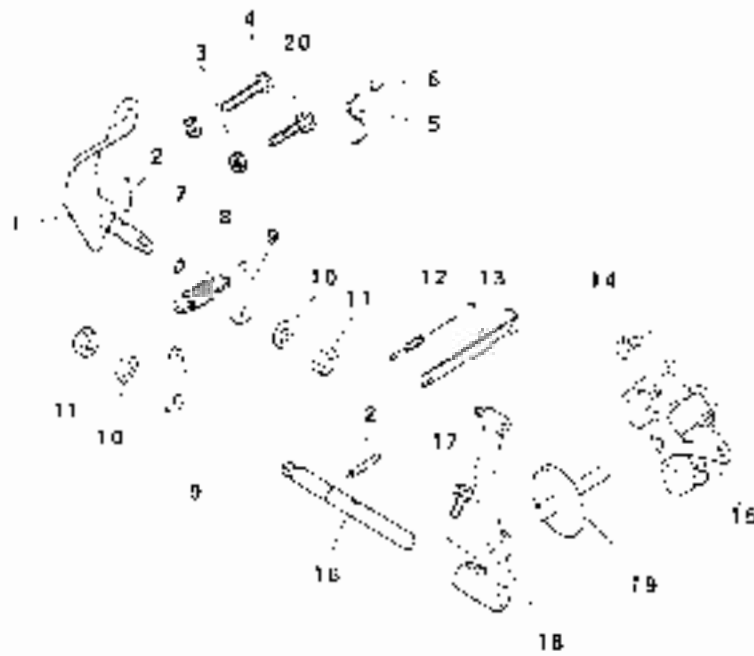

Key No	Parts No	Parts Name	Qty	Unit	App	Application	Description	Remarks
1	MM409237	CONTROL LEVER	1					
2	K8717530	PIN, grooved	2					
3	MF430004	NUT	2					
4	MM401060	BOLT	1					
5	MK98300140	WIRE	1					
6	MK98200001	METAL, sealing	1					
7	MF520002	O-RING	2					
8	MM409166	SPRING	1					
9	MM407035	LEVER, governor	2					
10	MF450405	WASHER, spring	3					
11	MF430725	NUT, jam	3					
12	MM409182	SPRING, tie rod	1					
13	MM409181	ROD, tie	1					
14	MF241222	BOLT, w/washer	3					
15	MM407006	WEIGHT ASSY	1					
	○	WEIGHT ASSY	1					
16	MM407031	SHAFT, governor	1					
17	MF244823	BOLT w/washer	1					
18	MM407028	LEVER ASSY	1					
19	MM407010	SHAFT ASSY	1					
20	MM401062	BOLT	1					

FIG.133 GOVERNOR & CONTROL PARTS (2/2)

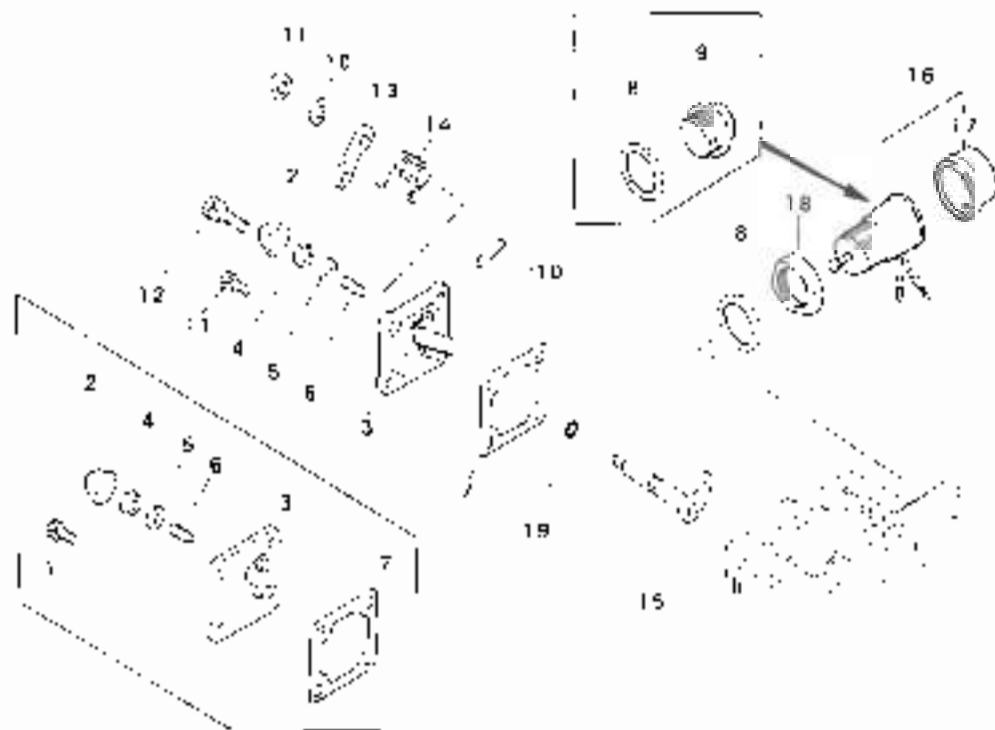

Key No	Parts No	Parts Name	Qty	Application	Description	Remarks
1	M241224	BOLT w/washer	4	10-140	ME4 A	Cover
2	MM409189	CAP sealing	1			
3-6	MM409640	COVER ASSY.	1			
	○	COVER ASSY.	1	A		Cover
3	*	COVER	1			
4	MM409166	NUT, special	1		ME	
5	MF560031	GASKET	1			
	○	WASHER seal	1	A		Cover
6	MM409167	SCREW, adjusting	1		ME417	
7	MM409151	GASKET, cover	1			
9	MF560042	GASKET	1		330	
3	MM409572	PLUG	1	10-162		cover
10	RR712E30	P.N. grooved	3			
11	M241225	BOLT	3		ME418	
12	M241231	BOLT	1		ME450	
13	MM409586	LEVER, stop	1			
14	MM413362	SPRING, return	1			
15	MM413360	LEVER ASSY	1			
16	MM409670	SOLENOID ASSY	1			ME419
17	MM317093	CAP gum	1			
18	MM409571	NUT	1			

FIG. 134 OIL PUMP

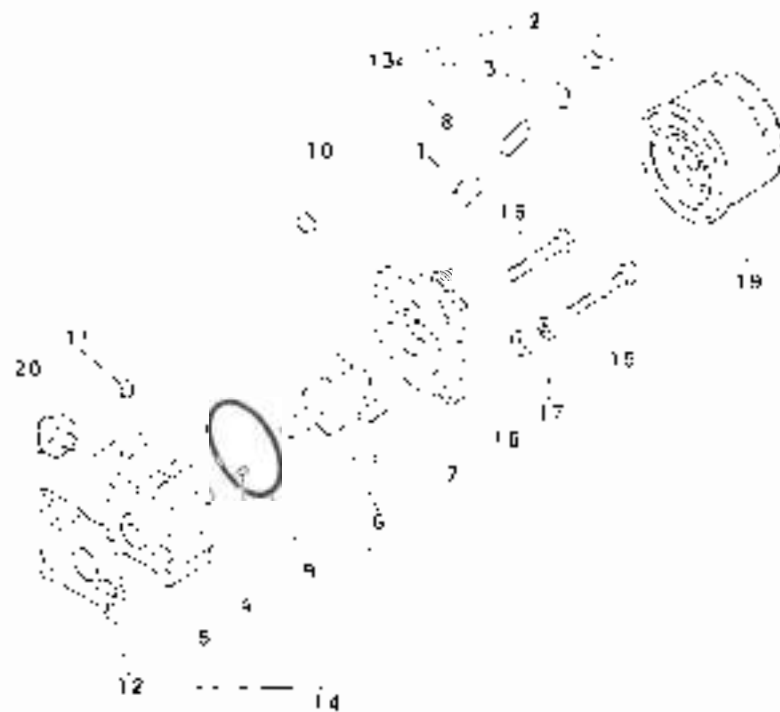

Key No	Parts No	Parts Name	QTY	Application	Description	Remarks
1-11	MM403371	OIL PUMP ASSY	1			
1	MD001402	PLUNGER,retel	1			
2	MD001404	PLJC	1			
3	MD000312	GASKET	1		oil	
4	MM403372	PIN dowel	2			
5	MM403241	BODY,oil pump	1			
6	MM407124	ROTOR ASSY	1			
7	MM403372	COVER,oil pump	1			
8	MM403204	SPRING,retel	1			
9	MM407144	O-RING	1			
10	MS661121	PLUG,taper	1		oil	
11	MS661120	PLUG,taper	1		oil	
12	WV407124	GASKET,oil pump	1			
13	MM403663	SERVICE KIT	48			to the mark
14	WV403664	SERVICE KIT	48			to the mark
15	MF101288	ROIL	3		oil	
16	MF101287	ROIL	1		oil	
17	MF450405	WASHER, spring	3		oil	
18	MS460035	WASHER	3		oil	
19	MD031805	OIL FILTER ASSY	1			
20	MM431717	PRESSURE SWITCH	1	oil		
	0	PRESSURE SWITCH	1	oil		

FIG. 135 LUBRICATING PARTS

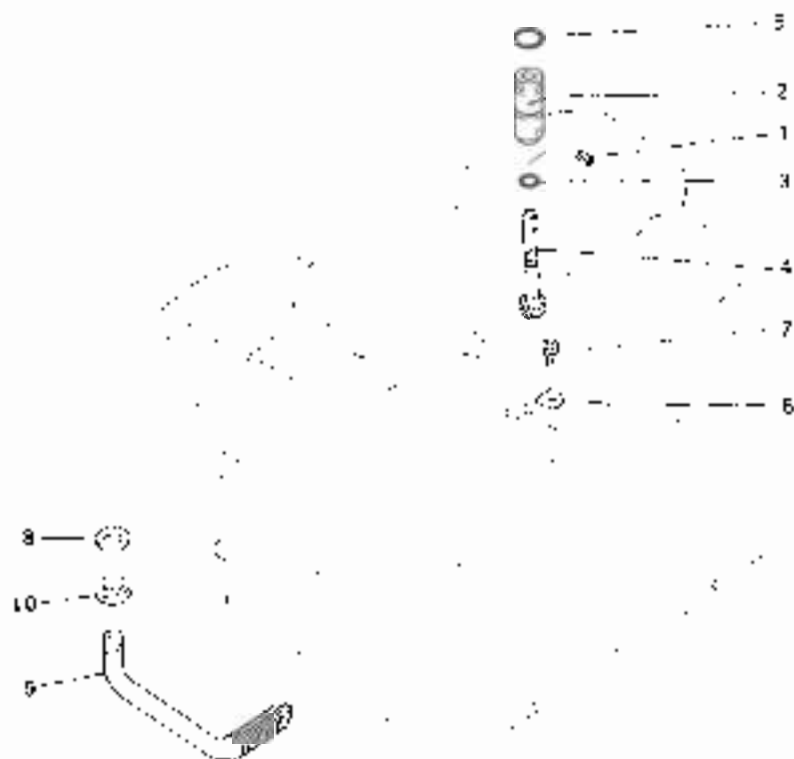

Key No	Parts No	Parts Name	Q T Y		Application	Descriptor	Remarks
			ALL	M			
1-5	WM430588	DRIVEN UNIT	.	.	3193		
	○	DRIVEN UNIT	.	.	A		WM430588
1	MF172536	Pin, spring	.	.	3492		WM430588
	○	Pin, spring	.	.	A		WM430588
2	WM430419	SLEEVE gear	.	.	3425		WM430588
	○	SLEEVE gear	.	.	A		WM430588
3	MD701798	O-RING	.	.			
4	MM407171	GEAR driven	.	.			
5	MF620012	O RING	.	.		918	
6	MD701789	PLATE locking	.	.			
7	MF241224	BOLT, w/washer	.	.		16214	
8	MF680036	GASKET	.	.			
9	WM430179	SCREEN ASSY	.	.			
10	MF430728	NUT, pm	.	.			

FIG.136 FAN & WATER PUMP

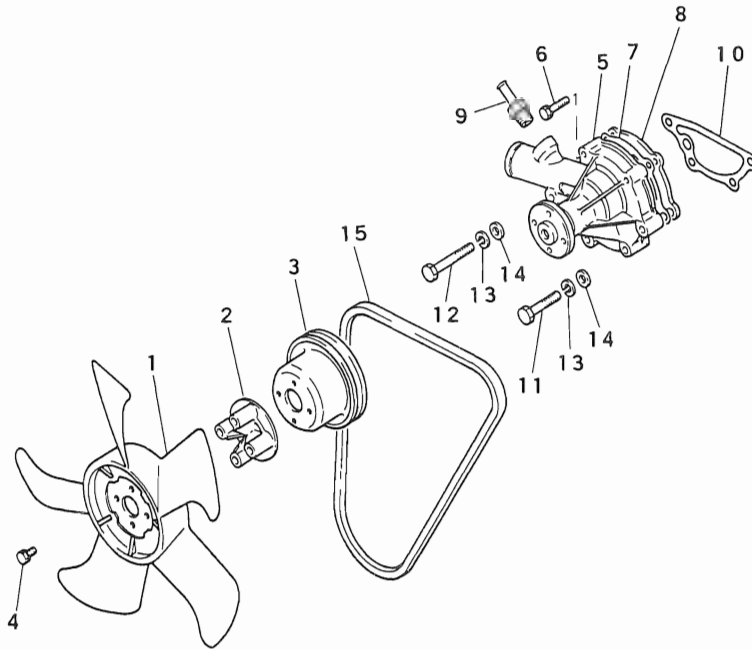

Key No	Parts No	Parts Name	Q'ty				P/B	Application	Description	Remarks
			ALL							
1	MD009014	FAN,cooling	1					φ340X5.S		
	○	FAN,cooling	1				A	φ340X5.S	MM407455	
2	MD011338	SPACER,fan	1					φ30		
3	MM405460	PULLEY,pump	1							
4	MF241236	BOLT,w/washer	4							
5-9	MM407402	PUMP ASSY.	1					M6X45		
5	*	PUMP,water	1							
6	MF240031	BOLT,w/washer	2					M6X30		
7	MM409326	GASKET	1							
8	MM409327	PLATE	1							
9	MM409314	JOINT	1							
10	MM407422	GASKET	1							
11	MF101264	BOLT	3					M8X45		
12	MF101267	BOLT	1					M8X60		
13	MF450405	WASHER,spring	4					M8		
14	MS450035	WASHER	4					M8		
15	MD041704	BELT,fan	1						(HM Poc = 972)	

FIG. 137 COOLING PARTS

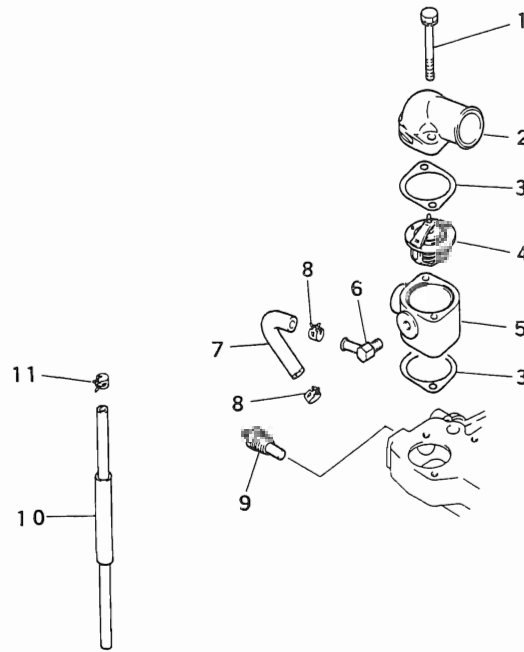

Key No	Parts No	Parts Name	Q' t y				P	Application	Description	Remarks
			ALL							
1	MF241267	BOLT,w/washer	2					M8X70		
2	MD008771	FITTING,outlet	1							
3	MD000551	GASKET	2							
4	MD001370	THERMOSTAT	1							
5	MM409334	FITTING	1							
6	MM409311	JOINT,water	1							
7,8	MM409336	HOSE ASSY.	1							
7	*	HOSE	1							
8	MS660164	CLIP,hose	2					φ13.1		
9	MM409381	SWITCH,thermo	1							
10, 11	MM413740	HOSE ASSY.	1					φ11.6		
10	*	HOSE	1					φ6X400		
11	MS660163	CLAMP,hose	1					φ11.6		

FIG. 139 ELECTRICAL EQUIPMENT

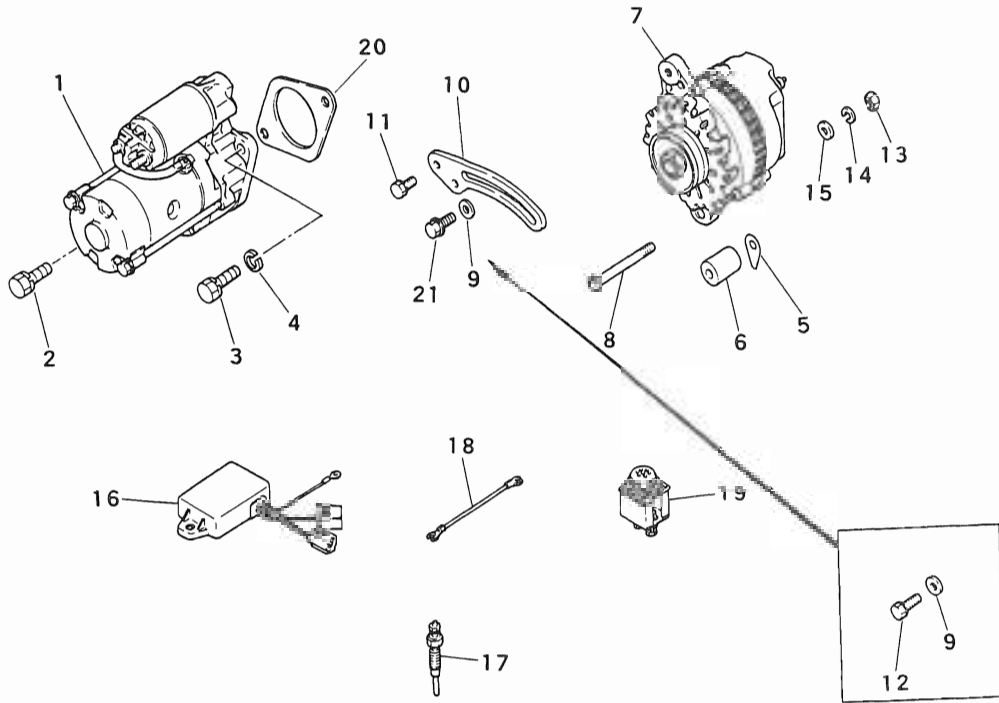

Key No	Parts No	Parts Name	Q' t y				P	Application	Description	Remarks
			ALL							
1	MM409412	STARTER ASSY.	1							
2	MF241282	BOLT,w/washer	1					M10X25		
3	MM409420	BOLT,starter	1							
4	MF450406	WASHER,spring	1							
5	MD001517	SHIM	AR							
6	MM407655	SPACER	1							
7	MD017645	ALTERNATOR ASSY	1							
8	MD017625	BOLT	1					M8X85		
9	MD001521	WASHER,plain	1				1750~			
	○	WASHER	1				A		MD000425	
10	MM413829	BLACE	1							
11	MF241251	BOLT,w/washer	1					M8X16		
12	MF241255	BOLT,w/washer	1					M8X25		
13	MF430005	NUT	1					M8		
14	MF450405	WASHER,spring	1					M8		
15	MS450035	WASHER	1					M8		
16	MM409675	TIMER UNIT	1							
17	MM409510	PLUG,glow	3						Y-114T	
18	MM409511	WIRE,glow plug	2							
19	MM409515	LAMP,glow	1							
20	MM409419	GASKET,starter	1							
21	MF140026	BOLT,flange	1				1750~			

FIG. 140 STARTER

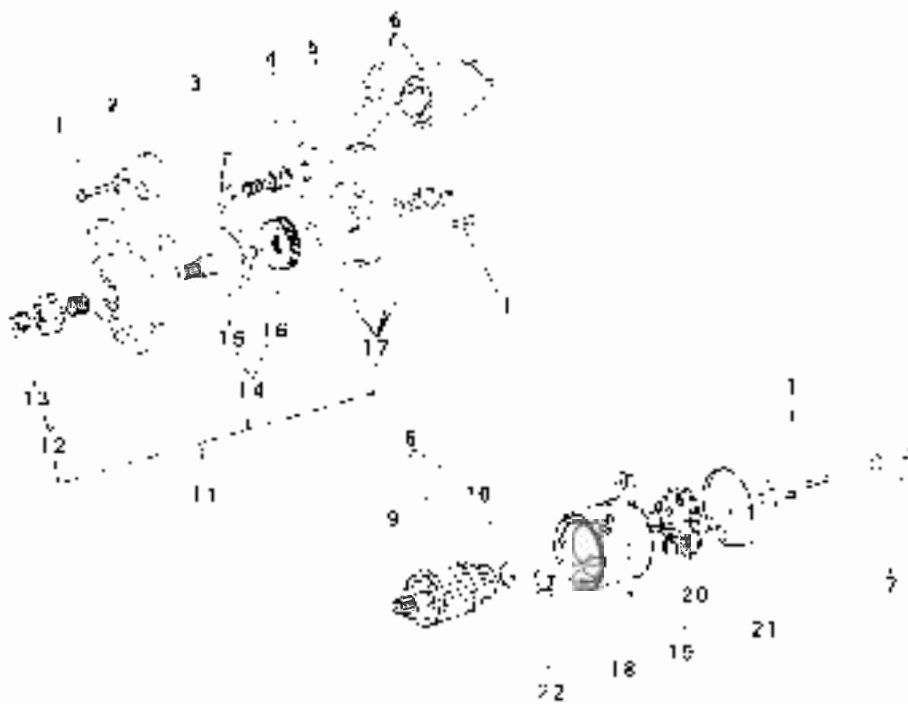

Key No.	Parts No.	Parts Name	AM	Application	Destruction	Remarks
1-22	MM403412	STARTER ASSY.	1			0000000
1	MD507631	SCREW SET	1			0000000
2	MM502436	BRACKET ASSY	1			0000000
3	MD607623	LEVER ASSY.	1			0000000
4	MD507445	SPRING SET	1			0000000
5	MM502441	BRACKET ASSY	1			0000000
6	MD607634	SWITCH ASSY	1			0000000
7	MD507635	BOLT SET	1			0000000
8	MD507630	ARMATURE SET	1			0000000
9	MD507643	BEARING front	1			0000000
10	MD507639	BEARING rear	1			0000000
11	MM502438	CLUTCH ASSY	1			0000000
12	ME700124	PINION SET	1			0000000
13	ME700124	STOPPER SET	1			0000000
14	MM502442	GEAR SET	1			0000000
15	MD507647	SHAFT ASSY	1			0000000
16	MM502443	GEAR	1			0000000
17	ME700125	COVER SET	1			0000000
18	MM502440	YOKE ASSY	1			0000000
19	ME700177	HOLDER ASSY.	1			0000000
20	ME700128	SPRING, brush	4			0000000
21	MD507645	BRACKET, rear	1			0000000
22	MM502444	PACKING	1			0000000

FIG. 141 ALTERNATOR

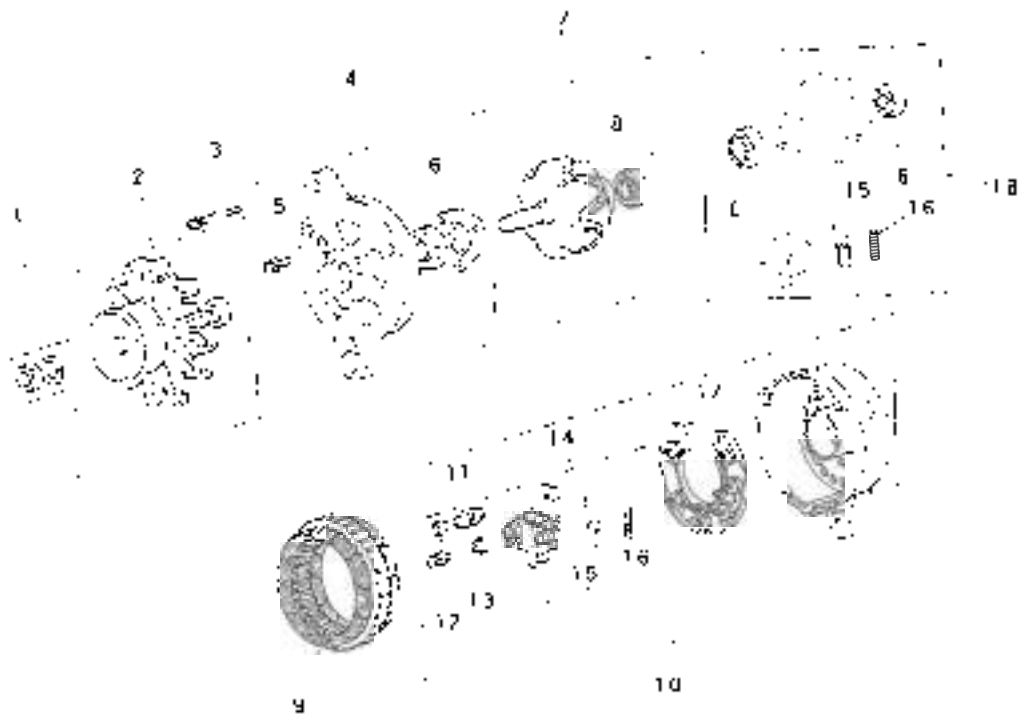

Key No	Parts No	Parts Name	QTY	APPL	Description	Remarks
1-18	MD017645	ALTERNATOR ASSY				62-117750-0
1	MM502340	NUT SET				62-2307-11
2	MD507170	PULLEY ASSY.				62-1308-10
3	MD507212	SCREW SET				61-4410-11
4	MD507267	BRACKET ASSY.				61-4410-11
5	MD502938	SCREW SET				61-4405-11
6	MD502254	BEARING front				50-15755-10
7	MM502298	ROTOR ASSY.				62-50121-10
8	MD502739	BEARING				51-15754-10
9	MM502293	STATOR				62-1125-10
10	MD507258	BRACKET ASSY				62-1125-10
11	MD507176	NUT SET				62-2307-11
12	MF360768	SCREW w/washer			MS21	52-420-10
13	MD502826	MOLD				61-150-011
14	MD502797	BRUSH ASSY				62-1700-11
14	*	BRUSH HOLDER				
15	MD502733	BRUSH	2			61-256-10-11
16	MD602227	SPRING brush	2			61-256-10-11
17	MD501209	RECTIFIER ASSY				62-1125-10
18	MM403837	SERVICE KIT	AP			61-1125-10

FIG. 142 REPAIR GASKET KIT

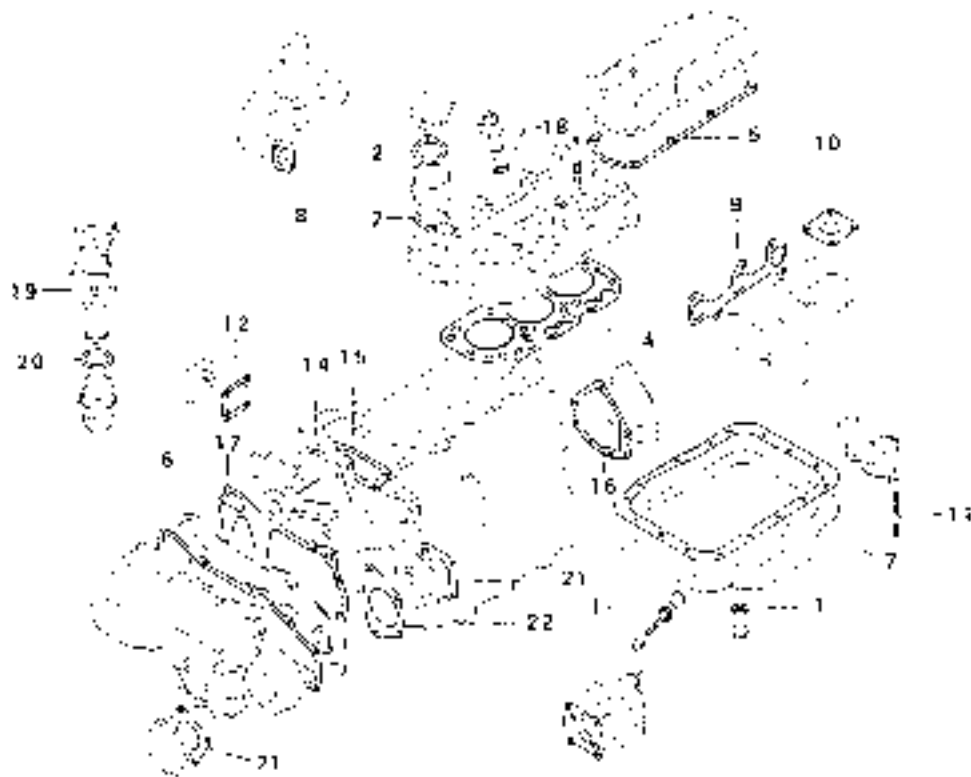

Key No	Parts No	Parts Name	QTY	Application	Designator	Remarks
1-22	MM344007	GASKET KIT	1			
1	M/D000312	GASKET	2			
2	M/D000351	GASKET	2			
3	M/M412050	SEAL valve stem	6			
4	M/M412540	GASKET cylinder	1			
5	M/M412572	GASKET cover	1			
6	MM406416	GASKET case	1			
7	MM412951	GASKET oil pan	1			
8	MM407305	GASKET	3			
9	MM412565	GASKET	1			
10	MM409561	GASKET	2			
11	MM406228	SEA...side	4			
12	MM409151	GASKET cover	1			
13	MM407124	GASKET oil pump	1			
14	MM409326	GASKET pump	1			
15	MM407422	GASKET pump	1			
16	MM406241	GASKET oil seal	1			
17	MM406265	GASKET plate	1			
18	K6510430	GASKET holder	3			
19	MM404881	O-RING element	1			
20	MM404878	O-RING cup	1			
21	MM401206	GASKET cover	2			
22	MM407261	GASKET housing	1			

