



Operator's Manual

A3 Series

HiTech

About this manual

This operator's manual is for Valtra A3 Series tractors. The A3 models are A83 h and A93 h.

The manual is meant for agricultural tractors only. If the tractor is used for other applications, it is the owner's responsibility to ensure compliance with local regulations. In this case, always contact your dealer first.

The purpose of this manual is to enable the owner and operator to use the tractor in a proper manner. Providing that the instructions are followed carefully, the tractor will provide years of service in the tradition of Valtra.



WARNING: Before using the tractor, read and understand all the instructions in this manual. They must then be strictly followed when operating and maintaining the tractor.

IMPORTANT: When using the tractor, always follow all valid laws and regulations even if they are not specifically pointed out in this manual.

The manual contains detailed instructions for operating, servicing and maintaining the tractor.

Alternative equipment in the manual refers to equipment that can be selected when ordering the tractor.

Extra equipment refers to equipment which can be bought and installed on the tractor later.

Due to the continual development of the products, the content of this manual may not always correspond to the new product. Therefore, we retain the right to make alterations without prior notification.

Maintenance, repairs and adjustments which are not described in this manual require special tools and exact technical data. For such work contact your dealer who has specially trained personnel to help you.

Valtra Inc.

Tractor serial numbers

When ordering spare parts or service, give the model indication and serial numbers and, in some cases, the engine, front axle, cab and transmission numbers.

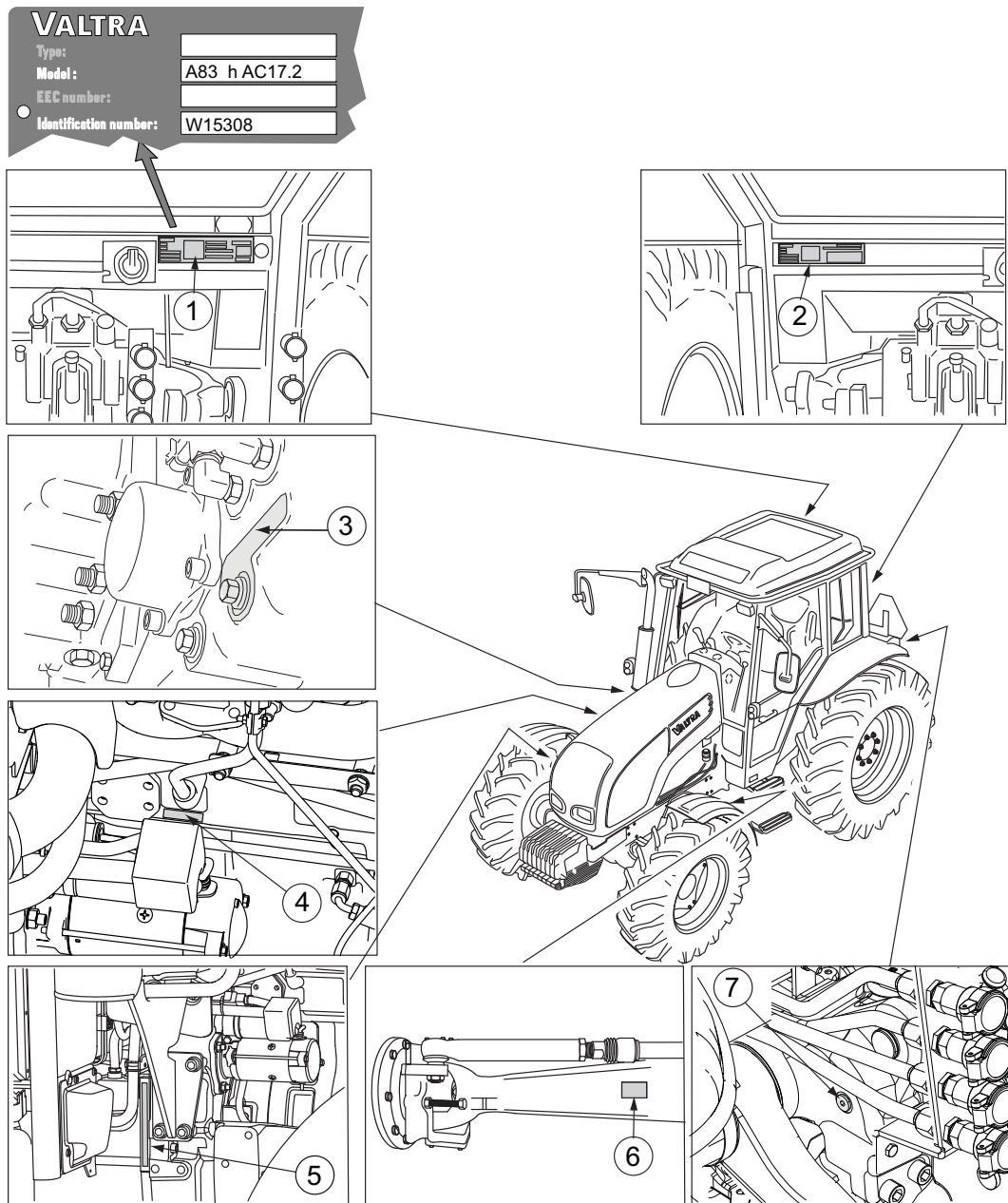

1. Type plate EEC

- Model = model indication used by service/spare part department
- Identification number = tractor serial number

2. Cab number

3. Transmission Identification number

4. Engine number

5. Tractor serial number

6. Front axle number

7. Power take-off identification number

Contents

About this manual.....	1
Tractor serial numbers.....	2
1 Safety precautions.....	10
1.1 Hazard statements.....	10
1.2 Safety rules.....	10
1.2.1 Replacing safety and information signs.....	10
1.2.2 Maintaining hardware safety.....	11
1.2.3 Using tractor safety features.....	12
1.2.4 Safe operation.....	13
1.2.4.1 Following safe operating practices.....	13
1.2.4.2 Getting into and out of the cab.....	14
1.2.4.3 Driving on public roads.....	15
1.2.4.4 Controlling the driving speed.....	15
1.2.4.5 Driving downhill.....	15
1.2.4.6 Operating with implements.....	16
1.2.4.7 Running with power take-off driven implements or machines.....	17
1.2.4.8 Using ballast weights.....	17
1.2.4.9 Towing.....	18
1.2.4.10 Ensuring personal safety of other people.....	18
1.2.4.11 Fire hazards.....	19
1.2.4.12 Handling viton seals subjected to high temperatures.....	19
2 Instruments and controls.....	20
2.1 Pedals.....	20
2.2 Dashboard.....	21
2.2.1 Infoline instrument panel.....	22
2.2.2 Proline instrument panel	22
2.2.2.1 Symbols on the Proline instrument panel display.....	23
2.2.3 Indicator lights on the left side of the display.....	24
2.2.4 Indicator lights on the right side of the display.....	25
2.3 Controls on the right-hand side.....	27
2.3.1 Driving controls.....	27
2.3.2 Linkage.....	28
2.3.3 Power take-off.....	29
2.3.4 Auxiliary hydraulics.....	30
2.3.5 Other controls.....	31
2.4 Controls on the rear side.....	32
2.4.1 Rear window opening device.....	32
2.5 Controls on the left-hand side.....	32
2.6 Controls on the front roof console.....	33
2.7 Air conditioning controls.....	33
2.7.1 Manual air conditioning controls	33
2.8 Driver's seat.....	34
2.9 Air suspended driver's seat	35
2.10 Controls on the rear mudguard.....	36
2.11 Rear controls and connections outside the cab.....	37
3 Operation.....	38
3.1 Running the tractor in.....	38
3.2 Preparing for use.....	38
3.2.1 Adjusting the driver's seat.....	38
3.2.2 Adjusting the air-suspended driver's seat.....	40
3.2.3 Adjusting the armrest.....	43
3.2.4 Adjusting the steering wheel.....	44

3.2.5	Adjusting mirrors.....	45
3.2.6	Using the windscreen wiper and washer.....	45
3.2.7	Using the rear window wiper.....	46
3.2.8	Using the rear window washer.....	46
3.2.9	Power shuttle lever.....	47
3.2.10	Using the main switch.....	47
3.2.11	Control stop.....	48
3.2.12	Using the control stop.....	49
3.2.13	Using the ignition switch.....	49
3.2.14	Using the roof hatch.....	51
3.3	Starting the tractor.....	51
3.3.1	Starting under normal conditions.....	51
3.3.2	Starting under cold conditions.....	53
3.3.3	Starting with an auxiliary battery.....	53
3.4	Using lights.....	54
3.4.1	Using headlights.....	54
3.4.2	Using upper headlights.....	55
3.4.3	Using working lights.....	55
3.4.4	Using the cab light.....	56
3.5	Using notification devices.....	56
3.5.1	Using the direction indicators.....	56
3.5.2	Using the horn.....	57
3.5.3	Using the rotating warning light.....	57
3.5.4	Using hazard warning flashers.....	58
3.6	Heating and ventilation.....	58
3.6.1	Using the heater.....	58
3.6.2	Using the extra heater.....	59
3.6.3	Controlling ventilation nozzles.....	60
3.6.4	Using the manual air conditioning.....	60
3.7	Power outlets.....	62
3.7.1	Lighter.....	62
3.7.2	Two-pin power socket.....	62
3.7.3	Three-pin power socket.....	63
3.7.4	Trailer socket.....	64
3.7.5	Two-pin power socket on the bonnet.....	64
3.8	Driving the tractor.....	65
3.8.1	Steering.....	65
3.8.2	Power shuttle.....	65
3.8.3	Using the power shuttle lever.....	66
3.8.4	Using the parking brake.....	66
3.8.5	Using the clutch pedal.....	68
3.8.6	Braking.....	69
3.8.7	Starting to drive.....	69
3.8.8	Transmission system.....	70
3.8.8.1	Selecting the range gear.....	71
3.8.8.2	Selecting the speed gear.....	72
3.8.9	Parking the tractor.....	72
3.8.10	Cruise control.....	73
3.8.10.1	Cruise control switches.....	73
3.8.10.2	Programming the driving speed cruise control.....	74
3.8.10.3	Activating and deactivating the driving speed cruise control.....	74
3.8.10.4	Programming the engine speed cruise control.....	76
3.8.10.5	Activating and deactivating the engine speed cruise control.....	77
3.8.10.6	Decreasing the cruise control setting.....	77
3.8.10.7	Increasing the cruise control setting.....	78
3.8.11	Automatic traction control.....	79
3.8.12	Using the automatic traction control.....	80
3.8.13	Differential lock.....	81

3.8.14	Engaging and disengaging the differential lock.....	81
3.8.15	Four-wheel drive.....	82
3.8.16	Engaging and disengaging the four-wheel drive.....	82
3.8.17	Engaging and disengaging the four-wheel drive automatic function.....	83
3.8.18	Driving start automatics.....	83
3.8.19	Activating and deactivating the driving start automatics.....	84
3.8.20	Permitted driving inclinations for driving the tractor on a slope.....	84
3.9	Proline instrument panel display.....	85
3.9.1	Fixed views.....	85
3.9.2	Selecting a view.....	86
3.9.3	Top and middle row views.....	86
3.9.3.1	Working time view.....	87
3.9.3.2	Cruise control view.....	88
3.9.3.3	Driving speed view.....	88
3.9.3.4	Rear power take-off speed view.....	88
3.9.3.5	Front power take-off speed view.....	89
3.9.3.6	Engine speed view.....	89
3.9.3.7	Fuel consumption views.....	89
3.9.3.8	Rear lower links' position view.....	91
3.9.3.9	Front lower links' position view.....	91
3.9.3.10	Gearbox temperature view.....	92
3.9.3.11	Travel distance view.....	92
3.9.3.12	Surface area view.....	93
3.9.4	Periodical maintenance view.....	93
3.9.4.1	Clearing the periodical maintenance view.....	93
3.9.5	Resetting views.....	94
3.9.6	Enlarging the middle row.....	95
3.9.7	Changing parameters.....	96
3.9.7.1	Activating and exiting the setting mode.....	96
3.9.7.2	Changing the parameter value.....	97
3.9.7.3	Setting the display backlight level.....	97
3.9.7.4	Setting the implement width.....	98
3.9.7.5	Changing the hour display.....	98
3.9.7.6	Changing the minute display.....	98
3.9.7.7	Changing the clock mode.....	99
3.9.7.8	Activating the direction indicator buzzer.....	99
3.9.7.9	Changing the temperature unit.....	99
3.9.7.10	Changing the length unit.....	100
3.9.7.11	Changing the volume unit.....	100
3.9.7.12	Activating and deactivating the front power take-off speed view.....	101
3.9.7.13	Activating and deactivating the front lower links' position view.....	101
3.9.7.14	Adjusting the display contrast.....	101
3.10	Rear linkage.....	102
3.10.1	Diagnose light.....	102
3.10.2	Lift/lower indicator lights.....	103
3.10.3	Activating the linkage.....	103
3.10.4	Using the lift/stop/lower switch.....	104
3.10.5	Using the position control knob.....	105
3.10.6	Using the linkage floating position.....	105
3.10.7	Using the lift/lower switch and lift/lower push buttons.....	107
3.10.8	Setting the lowering speed.....	107
3.10.9	Limiting the lifting height.....	108
3.10.10	Draft control.....	109
3.10.11	Activating and deactivating the draft control.....	110
3.10.12	Passing the position set by the position control knob.....	110
3.10.13	Passing the height set by the lifting height selector.....	111
3.10.14	Using the drive balance control.....	112
3.11	Three-point linkage.....	114

3.11.1	Attaching implements.....	115
3.11.2	Using telescopic lower links.....	117
3.11.3	Using quick couplings for lower links	117
3.11.3.1	Setting the release cable for lower link quick couplings	118
3.11.4	Adjusting lifting links	120
3.11.5	Adjusting lower links.....	120
3.11.6	Adjusting the check links' length.....	121
3.12	Auxiliary hydraulics.....	122
3.12.1	Controlling the auxiliary hydraulics rear valves 1 and 2.....	123
3.12.2	Controlling the auxiliary hydraulics rear valves 3 and 4.....	124
3.12.3	Setting valves for single-action or double-action.....	125
3.12.4	Using quick-action couplings	126
3.12.5	Connecting an external hydraulic motor to the auxiliary hydraulics.....	126
3.13	Using the front linkage.....	127
3.13.1	Setting front linkage lifting link positions.....	128
3.14	Using the Valtra front loader.....	129
3.14.1	Softdrive.....	131
3.14.2	Locking the equipment.....	131
3.14.3	Using the continuous floating position.....	132
3.14.4	Using the floating position with joystick buttons.....	133
3.14.5	Controlling the extra cylinder with the change valve.....	134
3.15	Power take-off.....	135
3.15.1	Attaching implements to the power take-off.....	135
3.15.2	Rear power take-off.....	137
3.15.2.1	Activating rear power take-off.....	138
3.15.2.2	Starting rear power take-off.....	139
3.15.2.3	Stopping rear power take-off temporarily.....	140
3.15.2.4	Deactivating rear power take-off.....	141
3.15.2.5	Stopping the rear power take-off in emergency.....	142
3.15.2.6	Using the rear power take-off automatic stop.....	143
3.15.3	Front power take-off.....	144
3.15.3.1	Using the front power take-off.....	144
3.16	Towing devices.....	145
3.16.1	Pick-up hitch.....	145
3.16.1.1	Unlatching the pick-up hitch	145
3.16.1.2	Latching the pick-up hitch.....	146
3.16.2	Agricultural drawbar devices.....	147
3.16.3	Towing device frames	148
3.16.3.1	Adjusting the jaw height.....	149
3.16.3.2	Attaching to the mechanical jaw.....	151
3.16.3.3	Attaching to the automatic jaw.....	151
3.17	Air pressure system.....	153
3.18	Trailer.....	155
3.18.1	Trailer air pressure brakes.....	155
3.18.2	Trailer fluid brake valve.....	156
4	Maintenance.....	158
4.1	Maintenance schedule.....	158
4.2	Service inspection.....	158
4.3	Performing maintenance tasks.....	159
4.3.1	Cleaning the tractor.....	160
4.3.1.1	Cleaning the engine compartment.....	161
4.3.2	Greasing lubricating points fitted with grease nipples.....	161
4.3.3	Supporting the tractor.....	161
4.4	Recommended fuel and lubricants.....	163
4.4.1	Fuel.....	163
4.4.1.1	Quality requirements for engine fuel.....	163
4.4.1.2	Storing fuel.....	163
4.4.1.3	Biodiesel fuel.....	164
4.4.2	Grease.....	164

4.4.2.1	Universal Grease - NLGI2 universal grease.....	164
4.4.2.2	Calcium LF - NLGI2 calcium grease LF.....	164
4.4.2.3	Grease Moly - NLGI2 moly grease.....	165
4.5	Storing the tractor.....	165
4.5.1	Storing the tractor for a period shorter than two months.....	165
4.5.2	Storing the tractor for a period longer than two months.....	165
4.6	Running the tractor in after storage.....	166
4.6.1	Running the tractor in after a storing period shorter than two months.....	166
4.6.2	Running the tractor in after a storing period longer than two months.....	166
4.7	Periodical maintenance.....	167
4.7.1	Periodical maintenance chart.....	167
4.7.2	Daily maintenance.....	169
4.7.2.1	Checking the engine oil level.....	169
4.7.2.2	Checking the oil level in the transmission system.....	170
4.7.2.3	Checking the coolant level.....	171
4.7.2.4	Cleaning radiators.....	172
4.7.2.5	Draining the water from the air pressure system.....	173
4.7.3	Weekly maintenance.....	173
4.7.3.1	Greasing the three-point linkage.....	173
4.7.3.2	Checking the pick-up hitch.....	174
4.7.3.3	Greasing the pick-up hitch.....	174
4.7.3.4	Maintaining the front linkage.....	175
4.7.3.5	Checking the front power take-off.....	176
4.7.3.6	Greasing front axle mounting bearings.....	176
4.7.3.7	Checking belts' tension.....	177
4.7.3.8	Adjusting the air conditioning compressor belt.....	177
4.7.3.9	Adjusting the air compressor belt.....	178
4.7.3.10	Changing the belts.....	178
4.7.3.11	Checking the fuel system prefilter and sediment bowl.....	181
4.7.3.12	Checking the tyre pressure.....	183
4.7.3.13	Checking wheel nuts' tightness.....	183
4.7.3.14	Windscreen washer fluid reservoir.....	183
4.7.4	Maintenance every 500 hours.....	183
4.7.4.1	Greasing door hinges.....	183
4.7.4.2	Changing the engine oil and the oil filter.....	184
4.7.4.3	Checking the breather pipe.....	185
4.7.4.4	Checking the brake fluid level.....	186
4.7.4.5	Cleaning the cab ventilation air filter.....	186
4.7.4.6	Cleaning the extra heater's air filter.....	187
4.7.4.7	Checking the brake pedal free travel.....	188
4.7.4.8	Adjusting brake pedals' travel.....	188
4.7.4.9	Checking the parking brake.....	190
4.7.4.10	Adjusting the parking brake.....	190
4.7.4.11	Changing transmission oil filters.....	193
4.7.4.12	Changing hydraulic system oil filters.....	194
4.7.4.13	Checking the oil level in the front axle differential.....	195
4.7.4.14	Checking the oil level in front axle hubs.....	195
4.7.4.15	Changing front PTO housing oil and washing oil filter.....	196
4.7.4.16	Checking front PTO rubber couplings.....	197
4.7.4.17	Checking and greasing the trailer air-pressure brake system.....	197
4.7.4.18	Adjusting engine valves.....	198
4.7.5	Maintenance every 1000 hours or yearly.....	198
4.7.5.1	Changing oil in the transmission system.....	198
4.7.5.2	Cleaning the suction strainer.....	199
4.7.5.3	Changing the transmission breather.....	200
4.7.5.4	Changing oil in the front axle differential.....	201
4.7.5.5	Changing oil in the front axle hubs.....	201
4.7.5.6	Changing the cab ventilation air filter.....	202
4.7.5.7	Changing the extra heater's air filter.....	202

4.7.5.8	Changing engine air filters.....	204
4.7.5.9	Cleaning the cyclone block.....	206
4.7.5.10	Greasing the flywheel ring gear.....	207
4.7.5.11	Checking the front wheel toe-in.....	207
4.7.5.12	Adjusting toe-in of front wheels.....	208
4.7.5.13	Checking the power shuttle operation.....	209
4.7.5.14	Tightening frame nuts and bolts.....	209
4.7.6	Maintenance every 2000 hours or every other year.....	209
4.7.6.1	Changing the brake fluid.....	209
4.7.6.2	Bleeding the brake system.....	210
4.7.6.3	Cleaning the cooling system.....	212
4.7.6.4	Maintaining the air conditioning.....	215
4.8	Checks and adjustments.....	216
4.8.1	Changing tyres.....	216
4.8.2	Track widths.....	216
4.8.2.1	Front axle track widths.....	217
4.8.2.2	Rear axle track widths.....	217
4.8.3	Using chains.....	218
4.8.4	Using twin-mounted wheels.....	218
4.8.5	Engine.....	218
4.8.5.1	Bleeding the fuel system.....	218
4.8.6	Electrical system.....	219
4.8.6.1	Safety precautions for the electrical system.....	219
4.8.6.2	Checking the battery.....	220
4.8.6.3	Alternator.....	220
4.8.6.4	Protecting the electrical system before welding.....	220
4.8.6.5	Fuses and relays.....	221
4.8.6.6	Fuses and relays in the electric centre.....	222
4.8.6.7	Engine induction air preheater fuse.....	224
4.8.6.8	Cab power supply fuse.....	224
4.8.6.9	Engine control unit fuse.....	225
4.8.6.10	Adjusting headlights.....	225
4.8.7	Steering system.....	226
4.8.7.1	Adjusting the steering angle.....	226
4.8.8	Cab and shields.....	227
4.8.8.1	Limiting the door opening.....	227
4.8.8.2	Checking and adjusting front mudguards.....	227
4.8.9	Hydraulic system.....	228
4.8.9.1	Adjusting lifting links of the pick-up hitch.....	228
4.8.9.2	Maintaining the automatic jaw of the wagon towing device.....	229
5	Faults and remedial actions.....	230
5.1	Handling error situations.....	230
5.2	Errors indicated by the indicator lights.....	230
5.2.1	Cleaning the main engine air filter.....	231
5.2.2	Identifying a blocked transmission or hydraulic system filter.....	232
5.3	Warning symbols on the Proline instrument panel display.....	234
5.3.1	Low fuel pressure warning.....	234
5.3.2	Fuel level sensor open circuit warning.....	234
5.3.3	Fuel level sensor short circuit warning.....	235
5.4	Steering system malfunctions.....	235
5.5	Towing the tractor.....	236
5.5.1	Towing the tractor when the engine is running.....	236
5.5.2	Towing the tractor when the engine is not running.....	236
6	Technical specifications.....	237
6.1	Dimensions.....	237
6.2	Weights.....	237
6.3	Maximum permissible axle loading.....	237
6.4	Tyres.....	237

6.4.1	Wheel nuts tightening torque.....	238
6.4.2	Wheel stud dimensions.....	238
6.4.3	Front axle tyre loadings and pressures.....	238
6.4.4	Rear axle tyre loadings and pressures.....	238
6.5	Spacing for wheel discs.....	239
6.6	Track widths.....	239
6.6.1	Rear track widths.....	239
6.6.2	Front track widths.....	239
6.7	Engine.....	240
6.7.1	Engine lubrication system.....	240
6.7.2	Fuel system.....	240
6.7.3	Air cleaner.....	240
6.7.4	Cooling system.....	241
6.8	Electrical system.....	241
6.9	Power transmission.....	241
6.9.1	Power shuttle.....	241
6.9.2	Clutch.....	242
6.9.3	Gearbox.....	242
6.9.4	Rear axle differential lock.....	242
6.9.5	Rear power take-off.....	242
6.9.5.1	Rear power take-off alternatives.....	242
6.9.5.2	Rear power take-off ratios.....	242
6.9.5.3	Rear power take-off shafts.....	243
6.9.5.4	Lower link end distance from rear power take-off shaft.....	243
6.9.5.5	Maximum power take-off output.....	243
6.9.6	Front power take-off.....	243
6.9.6.1	Front power take-off ratios.....	243
6.9.6.2	Front power take-off shafts.....	243
6.10	Brake system.....	244
6.11	Steering system.....	244
6.11.1	Front axle.....	244
6.11.2	Turning circle radius.....	245
6.12	Cab and shields.....	245
6.12.1	Cab filter capacity.....	245
6.12.2	Windscreen washer.....	245
6.12.3	Air conditioning system.....	245
6.12.4	Noise level.....	246
6.12.5	Exposure to vibration.....	246
6.13	Hydraulic system.....	246
6.13.1	Low pressure circuit.....	246
6.13.2	High pressure circuit.....	246
6.13.3	Auxiliary hydraulics.....	246
6.13.3.1	Valves for auxiliary hydraulics.....	246
6.13.3.2	Counter pressure when using the return connection for auxiliary hydraulics.....	247
6.13.4	Rear linkage.....	247
6.13.4.1	Maximum lifting force on the whole lifting area	247
6.13.4.2	Lifting range at the end of the lower links.....	247
6.13.5	Front linkage.....	247
6.13.6	Trailer hitches and towing devices.....	248
6.13.6.1	Pick-up hitch.....	248
6.13.6.2	Agricultural towing device.....	248
6.13.6.3	Towing device frames.....	249
6.13.6.4	Drawbar eye.....	249
Alphabetical index.....		250

1 Safety precautions

Always follow the safety precautions given when working with the tractor.

The regulations given do not release the operator from statutory and other national regulations as regards traffic safety and occupational health and safety.

In addition to the precautions given in this manual, always follow the safety regulations applicable to different types of working sites and existing road traffic laws.

1.1 Hazard statements

Five symbols are used in the documentation.



DANGER: Indicates an imminently hazardous situation that, if not avoided, results in death or very serious injury.



WARNING: Indicates a potentially hazardous situation that, if not avoided, could result in death or serious injury.



CAUTION: Indicates a potentially hazardous situation that, if not avoided, may result in minor injury.

IMPORTANT: Indicates special instructions or procedures which, if not strictly observed, could result in damage to, or destruction of the machine, process or its surroundings.

NOTE: Indicates points of particular interest for more efficient and convenient repair or operation.

1.2 Safety rules

1.2.1 Replacing safety and information signs

Replacement signs are available from your dealer in the event of loss or damage.

- **Replace any danger, warning, caution or instruction signs that are not readable or are missing.**



WARNING: Do not remove or obscure danger, warning, caution or instruction signs.

1.2.2 Maintaining hardware safety

To ensure maximum safety for the operator, maintain tractor hardware safety. The owner is responsible for repairing any damage or wear which might endanger the safety of the tractor.

- **Cab**

Damages on the cab must be repaired without delay to ensure the cab's protective capability.



WARNING: If damage occurs to the cab, replace all parts affected with new ones. Do not attempt any repair work (welding, drilling, cutting, or grinding) without first consulting the manufacturer.

- **Tractor construction**

Do not change the tractor construction, such as maximum driving speed or maximum power.

The tractor is type approved to comply with construction and use regulations. Any changes to the tractor construction may reduce safety and durability and affect the warranty terms.

- **Brakes**

- Always check that the brakes are working before driving.
- Lock the brake pedals together whenever individual wheel brakes are not required and always when driving on the road.
- Extensive repairs to the braking system should be undertaken only by an authorised Valtra workshop.
- When implements or ballast weights are front-end mounted, the rear axle loading is decreased:
 - Check that the rear brakes are still effective.
 - Use appropriate ballast weights at rear as required.

- **Cleaning**

Keep the tractor clean to minimise risk of fire.

- **Lights**

- Make sure that lights and reflectors are clean and in working order.
- Make sure that the headlights are correctly adjusted.

- **Steps**

Keep the steps clean. Dirty steps can lead to falls and personal injury.

- **Quick couplings**



DANGER: Clean the quick couplings and ball joints before attaching an implement. There is risk that the implement is not attached properly.

1. Safety precautions

- **Maintenance**
 - Follow the maintenance instructions and safety precautions applicable to the tractor.
 - Stop the engine and lower the implement before carrying out any maintenance work on the tractor or implement.
 - Support the tractor from the correct support points on the frame and use suitable blocks or stands when carrying out maintenance tasks that require supporting the tractor.

1.2.3 Using tractor safety features

The tractor has several features that contribute to the operator's safety.

- **Steering wheel and safety handles**



WARNING: Hold on to the steering wheel or safety handles in the cab if the tractor tips over. Never try to jump out.

- **Safety belt**

Always use the safety belt when using the tractor.

- **Emergency exits**

Familiarise yourself with the four emergency exits of the tractor cab, that is, the doors, the rear window and the roof hatch (extra equipment).

- **Roof hatch (extra equipment)**

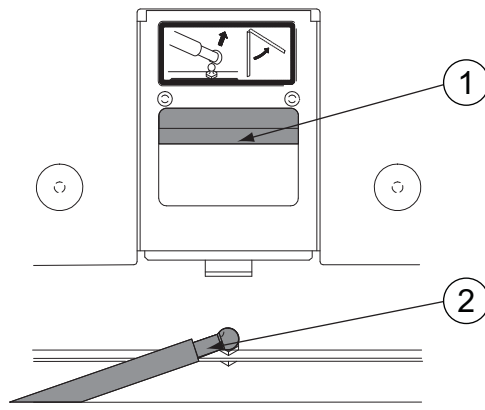

1. Handle
2. Gas spring

- Open the hatch by pushing the handle forward and pushing the hatch upward.
- To open the hatch fully (for emergency exit), detach the upper end of the gas spring from its fastener and push the hatch fully open.



WARNING: When driving on ice, keep the roof hatch open.

1.2.4 Safe operation

1.2.4.1 Following safe operating practices

To operate the tractor safely, follow all the safety precautions and instructions.

- **Avoid operating the tractor near ditches, embankments and holes.**
- **Stay off slopes too steep for safe operation.**
- **When using chemicals, carefully follow the chemical manufacturer's instructions for use, storage and disposal.**

Also follow the chemical application equipment manufacturer's instructions.

- **Protect yourself against motor noise.**

Use hearing protectors to avoid noise injuries when you are working outside the cab near the engine.

- **Avoid carbon monoxide poisoning.**



WARNING: To avoid carbon monoxide poisoning, do not start the engine or run it indoors with the doors closed unless the exhaust is vented to the outside.

- **Restarting after engine stop**

- If the engine has stalled, for example due to too heavy loading, turn the ignition key to the STOP position.
- Restart the engine.

Keep an eye on the indicator lights on the instrument panel.

- **Front loader**

- Ensure that no one is in the working area when you are working with a front loader.
- Lower the front loader to the down position before leaving the tractor.
- Observe any special instructions issued by the loader manufacturer.



WARNING: The risk of overturn increases as the loader is raised. Be extra careful on slopes when operating the loader. Always carry the loader as low as practical for the conditions.



WARNING: Always look at the implement. Objects can fall or roll backwards onto the driver when the loader is raised. Only lift loads which can be contained in, and are intended for, the specific implement.

- **Differential lock**

Use the differential lock only when running on loose or slippery ground.

1. Safety precautions

- **Overturning**
 - Always consider the way in which the tractor is to be used and the fact that the centre of gravity of the tractor/implement assembly changes according to the load being transported or towed.
 - Adapt the tractor speed according to visibility, weather conditions and the type of terrain.

 **WARNING:** The instructions concerning overturning in this manual are not exhaustive.
- **Hydraulic/fuel pressure**

Do not attempt to locate a leak in the hydraulic system or attempt to close a leak using any part of your body.

 **CAUTION:** Oil/fuel under high pressure easily penetrates through clothing and skin and can cause serious injury.
- **Hot surfaces**

 **CAUTION:** Be careful of hot surfaces during operation and service work, in particular the engine and hydraulics components.
- **Falling Object Protection Structure (FOPS)**

 **DANGER:** The cab structure is not designed for protection against falling objects (no FOPS).
- **Operator Protection Structure (OPS)**

 **DANGER:** Protection against penetrating objects is not provided (no OPS available).
- **Hazardous substances EN 15695-1:2009**

 **DANGER:** The cab is classified as category 1 according to the draft of EN15695-1:2009. Protection against dust or hazardous substances (agricultural chemicals, etc.) is not provided. Personal protective equipment must be used according to the chemical manufacturer's recommendations.
- **Forest work**
 - When working in forest, pay special attention to safety issues. The specific dangers related to forest work are overturning, falling objects and penetrating objects.

1.2.4.2 Getting into and out of the cab

When getting into and out of the cab, pay special attention to safety issues.

- **Always use three-point contact with the tractor and face the tractor when getting in and out.**
- **Use handrails, grab handles and steps when getting in and out.**
- **Do not use the control levers as a handhold.**
- **Do not step on pedals when getting in and out.**

- Never attempt to get into or out from a moving tractor.
- Never jump off a tractor.

1.2.4.3 Driving on public roads

When driving the tractor on public roads, pay special attention to the safety issues.

- **Before driving**
 - Check that the tractor is safe for driving on the road.
 - Adjust the rear view mirrors to give the correct viewing angle.
 - Lock the check links with pins when transporting implements using three-point linkage.
- **When driving the tractor on public roads**



WARNING: Do not transport anything on the auxiliary hydraulic valves while driving on the road. The load, trailer link steering and such have to be locked (for example mechanically).

- Use the slow moving vehicle emblem on the rear end of the tractor if allowed by law.

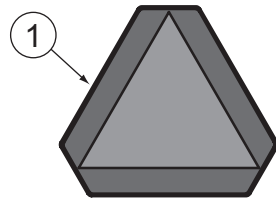

1. Slow moving vehicle emblem

1.2.4.4 Controlling the driving speed

Adjust the driving speed to suit the driving surface, visibility and load.

IMPORTANT: Do not alter the maximum driving speed of the tractor. The maximum reverse driving speed is 20 km/h.

- Avoid any sudden increase or reduction (braking) in the driving speed.
- Avoid tight turns at high driving speed.
- When driving the tractor with an attached implement which centre of gravity is far from the tractor, the tractor may sway considerably during cornering. If care is not taken, the tractor may tip over or the load may be displaced.

1.2.4.5 Driving downhill

Be careful when driving downhill.

- Check the brakes often.

1. Safety precautions

- **Change to a lower gear before driving down a steep incline.**

IMPORTANT: Do not brake continuously as the brakes may overheat.

IMPORTANT: Do not let the engine overrun to avoid damage to the engine.

NOTE: If the speed is too high, a speed warning is shown on the instrument panel display and a buzzer goes off.

1.2.4.6 Operating with implements

Read and follow the instructions to avoid unnecessary risks when operating with implements and attachments.



WARNING: Always follow carefully the instructions given in the implement's user documentation. It is not allowed to use an implement without reading and understanding all the precautions and regulations.



WARNING: Before entering between the tractor and the implement, prevent the tractor from moving by applying the parking brake or blocking the wheels. There is risk of accidents if the tractor or implement should move.



WARNING: Implements attached to the linkage or the auxiliary hydraulic system must be lowered to the ground while parking and during maintenance.



WARNING: When installing an implement, air in hydraulic hoses and cylinders can cause erratic operation. Run the engine at low speed and make slow movements with the joystick to purge any air from the hydraulic system.



WARNING: When installing an implement, keep hands and feet away from moving components. Do not use your fingers to check the alignment of holes or pins — use a mandrel or a steel rod.



WARNING: When disconnecting, the implement may fall downwards.

IMPORTANT: When attaching a trailer or implement, be sure not to exceed the maximum weight of the rear axle. See the technical specifications in this manual for the maximum permissible axle loading.

- **Make sure to allow sufficient clearance for turning.**

Three-point hitch and side-mounted implements make a much larger arc when turning than towed equipment. Use only Valtra approved attachments and implements.

- **Familiarise yourself with the working area and terrain.**

Pay attention to vertical clearance and limitations that arise due to the increased reach.

- Pull only from the approved drawbar.

Towing or attaching to other locations may cause the tractor to overturn.

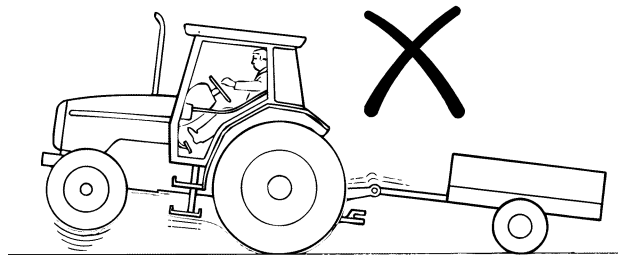
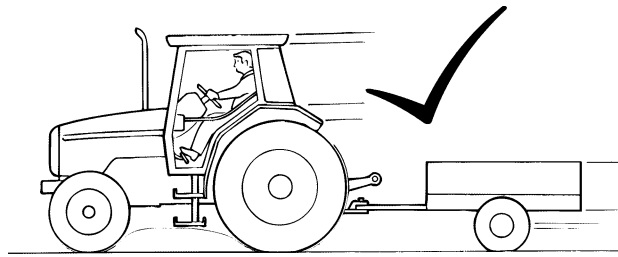

1.2.4.7 Running with power take-off driven implements or machines

Read and follow the given instructions to use power take-off (PTO) driven implements and machines safely.



DANGER: Serious accidents may occur due to failure to use the prescribed safety devices.

- Use the prescribed safety devices and ensure that they are in good condition.
- Follow the directions given by the implement or machine manufacturer.

1.2.4.8 Using ballast weights

Use ballast weights according to the instructions when needed.



WARNING: When driving on the road, at least 20% of the gross weight of the tractor must be on the front axle. When lifting an implement, the weight on the front end of the tractor is reduced, and the steering ability of the tractor is impaired or sometimes lost.

IMPORTANT: When using salt liquid as ballast weight in the wheels, the manufacturer does not take the responsibility for the damages caused by salt.

- Use sufficient ballast weights.
- Mount ballast weights only at the points intended for this purpose.

1. Safety precautions

1.2.4.9 Towing

Read and follow the given instructions to tow a trailer or an implement safely.



WARNING: When the tractor is towing a trailer, the brake pedals must be locked together. The brakes are not to be used individually for steering.



WARNING: When using a trailer, make sure that the hitch latch is locked.



WARNING: When using a trailer, always use the trailer brakes if required by law.



WARNING: Be sure no one is standing between tractor and implement.

IMPORTANT: When attaching a trailer or implement, be sure not to exceed the maximum weight of the rear axle. See the technical specifications in this manual for the maximum permissible axle loading.

IMPORTANT: When attaching a trailer or implement, be sure not to exceed the maximum load of the tyre type. See the technical specifications for maximum rear axle tyre loadings.

- Couple a trailer to the drawbar using an approved trailer coupling.
- Always lower a loaded drawbar with the hydraulic lift.
- Check that trailer brakes are operating properly and observe any special instructions issued by the trailer manufacturer.
- Secure the trailer load properly.



WARNING: On tractors with trailers, the load must be properly secured. The load must not obstruct the operator's vision, or cover lights and reflectors. Loads which project more than 1 m behind the vehicle train must be suitably marked. During daytime, this should be done with a flag, and during darkness, with a red light and a reflector arrangement.

1.2.4.10 Ensuring personal safety of other people

Avoid hazards for other people when using the tractor.



DANGER: Do not allow children in the cab or near the tractor or an attached implement while the engine is running.



DANGER: If the tractor engine is running, do not leave anybody in the cab without supervision, as the push buttons are easily operated. Always apply the parking brake.

- Stop the engine and lower the implement to the ground when leaving the tractor.
- Do not let passengers ride in the tractor unless it is provided with a special seat.
Other personal transport, for example on front-mounted loaders, is not permissible.
- Do not let passengers ride on the platform inside the tractor.
- Never lend the tractor to a person who is not used to driving it.



DANGER: You may be held responsible for any resulting accidents.

- Do not allow children, untrained or unqualified persons to operate your tractor. They could injure themselves or someone else.

1.2.4.11 Fire hazards



WARNING: Open fire, smoking and sparks are prohibited near the fuel system and batteries. Especially when charging batteries, explosive gases are present.

1.2.4.12 Handling viton seals subjected to high temperatures

At temperatures over 300°C, the viton seals of the engine produce highly corrosive hydrofluoric acid.

- Do not touch viton seals subjected to abnormally high temperatures with your bare hands.
Use neoprene rubber or heavy duty gloves and safety glasses when decontaminating.
- Wash seals and the contaminated area with 10% calcium hydroxide or other alkali solution.
- Put all the removed material in sealed plastic bags and deliver them to the point stated by the authorities concerned.



WARNING: Never burn viton seals.

2 Instruments and controls

2.1 Pedals

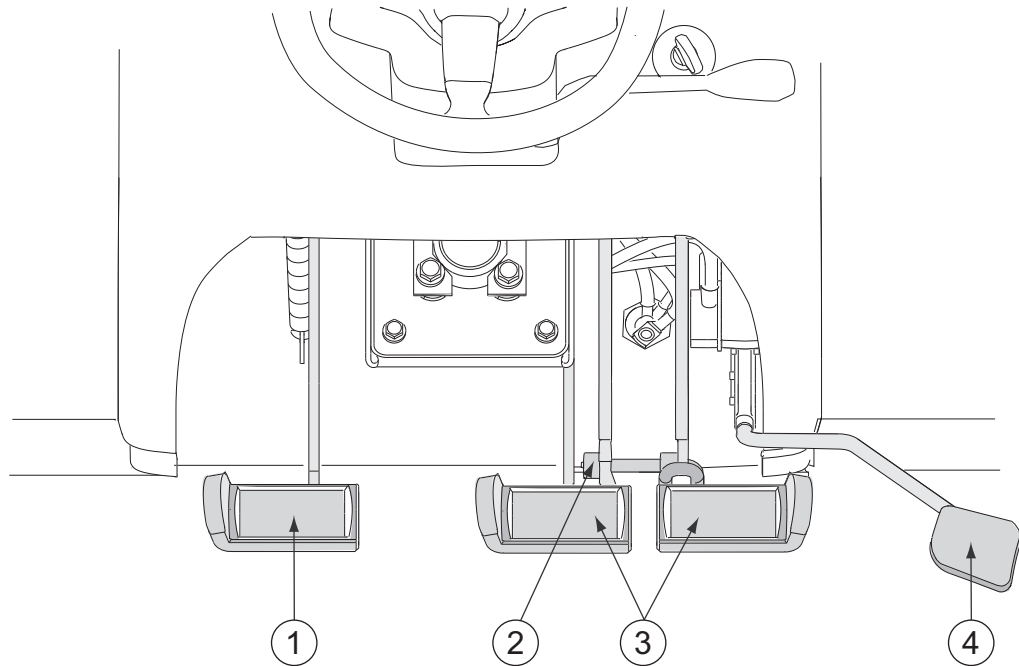

1. Clutch pedal
2. Latch for brake pedals
3. Brake pedals
4. Accelerator pedal

2.2 Dashboard

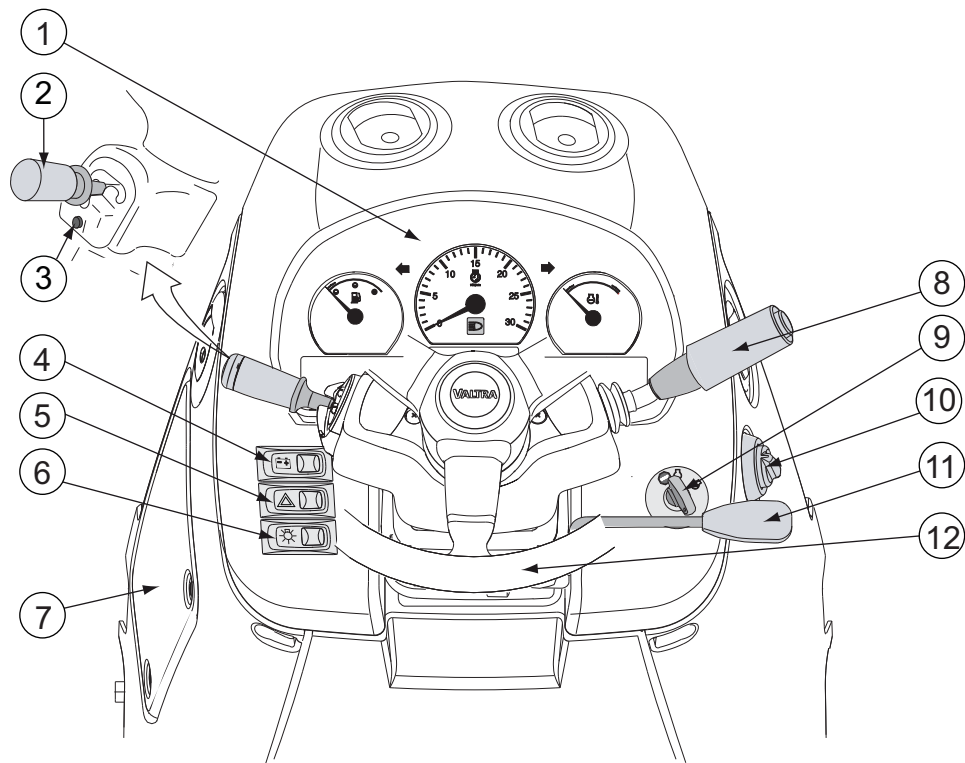

1. Instrument panel
2. Power shuttle lever
3. Preprogramming push button
4. Main switch (extra equipment)
5. Hazard warning flasher switch
6. Light switch
7. Electric centre
8. Multifunctional lever
9. Ignition switch
10. Heater adjustment knob
11. Lever for adjusting steering wheel position
12. Steering wheel

2.2.1 Infoline instrument panel

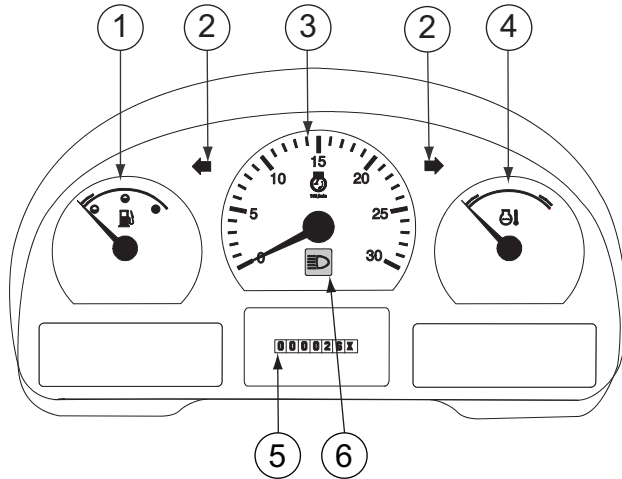

1. Fuel gauge
2. Indicator lights for direction indicator
3. Tachometer
4. Coolant thermometer
5. Operating hour meter
6. Indicator light for the main beam

The fuel gauge shows the amount of fuel left in the tank.

The coolant thermometer indicates the engine temperature. The zone between blue (cold) and red (hot) is the normal operating temperature.

2.2.2 Proline instrument panel

The operator receives information from the gauges, coolant thermometer, tachometer, speedometer and indicator lights. All this can be seen on the Proline instrument panel. The Proline instrument panel is an alternative equipment.

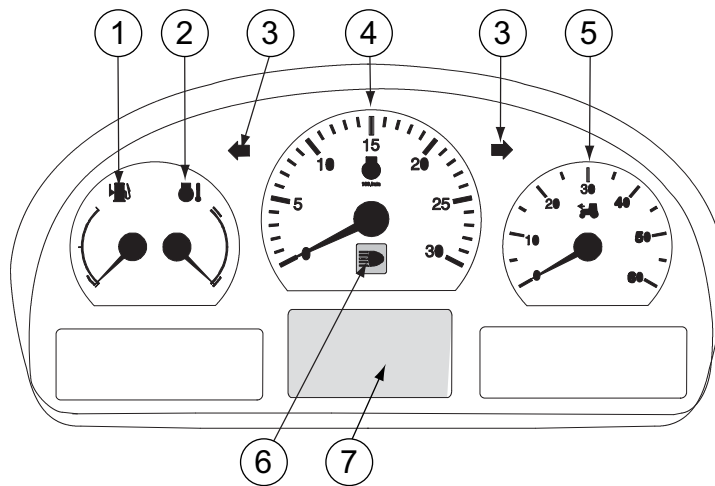

1. Fuel gauge
2. Coolant thermometer
3. Indicator lights for direction indicator
4. Tachometer
5. Speedometer
6. Indicator light for the main beam
7. Proline instrument panel display

The fuel gauge shows the amount of fuel left in the tank.

The coolant thermometer indicates the engine temperature. The zone between blue (cold) and red (hot) is the normal operating temperature.

2.2.2.1 Symbols on the Proline instrument panel display

The Proline instrument panel display has fixed views and views that can be selected by the operator.

Fixed view symbols

The fixed views are the two functions shown on the bottom row of the display:

Symbol	Function
	Operating hours (hhhh.h)
	Clock (hh:mm)

Selectable view symbols

The selectable views are the functions shown on the top and centre row of the display:

Symbol	Function
	Working time (h:mm)
	Cruise control
	Driving speed (km/h/mph)
	Rear power take-off (PTO) speed (rpm)

Table continued on next page

2. Instruments and controls





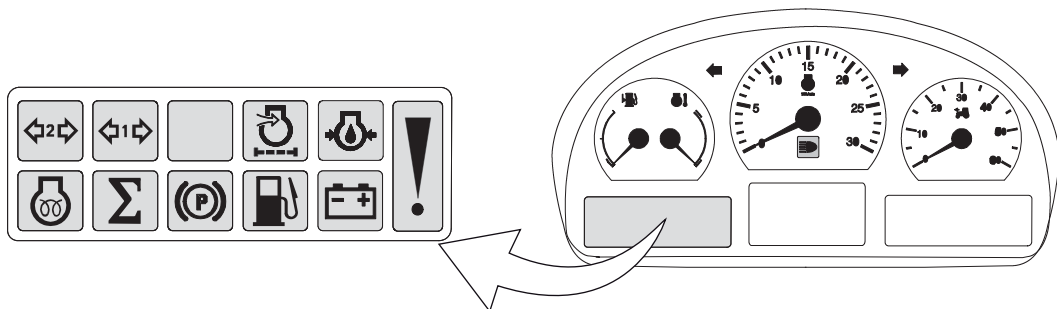

Symbol	Function
	Front power take-off (PTO) speed (rpm)
	Engine speed (rpm)
	Immediate fuel consumption (ha, acre)
	Average fuel consumption (ha, acre)
	Immediate fuel consumption
	Average fuel consumption
	Fuel consumption
AC_R	Lower link position (%; 0-100)
AC_F	Lifting link position of front linkage (%; 0-100)
	Gearbox temperature (C/F)
	Travel distance (m/km/miles)
	Square area (ha)
	Periodical maintenance

2.2.3 Indicator lights on the left side of the display



Indicator light	Indication
	Direction indicator light for second trailer (green). If one of the bulbs on the combination has failed, this light is not lit.
	Direction indicator light for first trailer (green). If one of the bulbs on the combination has failed, this light is not lit.
	Engine air cleaner clogging indicator light.
	Engine oil pressure light

Table continued on next page

Indicator light	Indication
	The exclamation mark is lit together with other indicator lights (yellow).
	Glow indicator light The light (yellow) is lit when the ignition key is in position  and the engine is cold.
	Σ-indicator light is used as a service code indicator light (flashing)
	Parking brake indicator light The light (red) is lit to indicate that the power shuttle lever is in the parking brake position.
	Low fuel level indicator light The light is lit (yellow) and a buzzer sounds once to indicate that about 50 litres of fuel is left.
	Battery charging indicator light

2.2.4 Indicator lights on the right side of the display

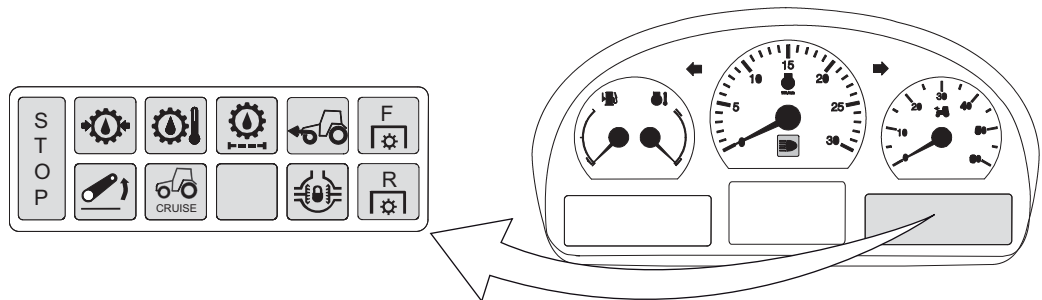











Indicator light	Indication
	STOP indicator light (red)
	Gearbox oil pressure light
	Gearbox oil temperature light
	Pressure oil filter clogging indicator light
	Four-wheel drive (4WD) indicator light The light is lit (yellow) to indicate that 4WD is engaged.

Table continued on next page

2. Instruments and controls

Indicator light	Indication
	Front power take-off (PTO) indicator light The light (yellow) is continuously on and indicates that the front PTO (extra equipment) is engaged.
	Rear linkage indicator light The light is on (yellow) to indicate that the lift/stop/lower switch is in lift (transport) position.
	Cruise control indicator light The light is on (yellow) to indicate that cruise control is engaged (constant driving speed/ constant engine speed chosen).
	Differential lock indicator light The light is lit (yellow) to indicate that the differential lock is engaged.
	Rear PTO indicator light The light blinks (yellow) when the rear PTO has been activated and is ready to operate. The light is on continuously when the rear PTO is engaged.

2.3 Controls on the right-hand side

2.3.1 Driving controls

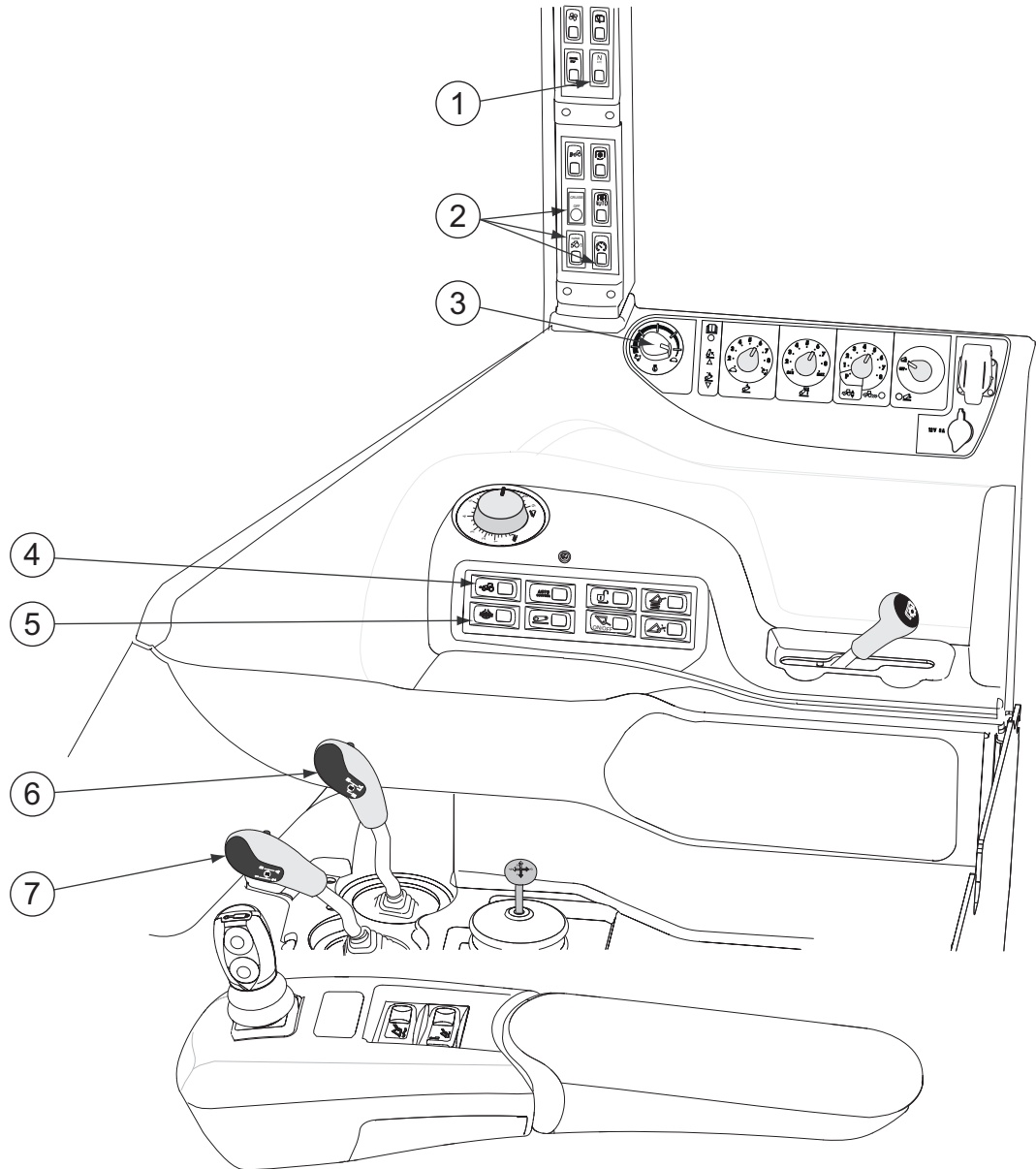

1. Switch for automatic traction control
2. Switches for cruise control (extra equipment)
3. Hand throttle
4. Switch for four-wheel drive (4WD)
5. Switch for differential lock
6. Range gear lever
7. Speed gear lever

2.3.2 Linkage

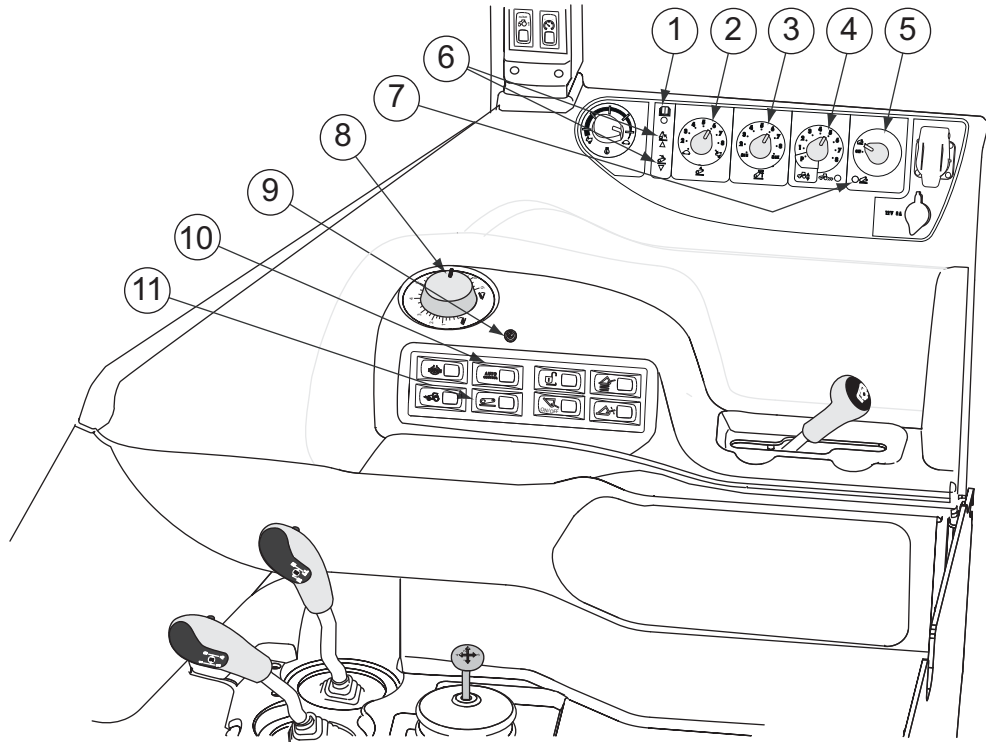

1. Diagnose light
2. Lowering speed selector
3. Lifting height selector
4. Draft control selector
5. Drive balance control
6. Lift/lower indicator lights
7. Drive balance control light
8. Position control knob
9. Passing switch for position control knob
10. Lift/stop/lower switch
11. Lift/lower switch

2.3.3 Power take-off

Rear power take-off

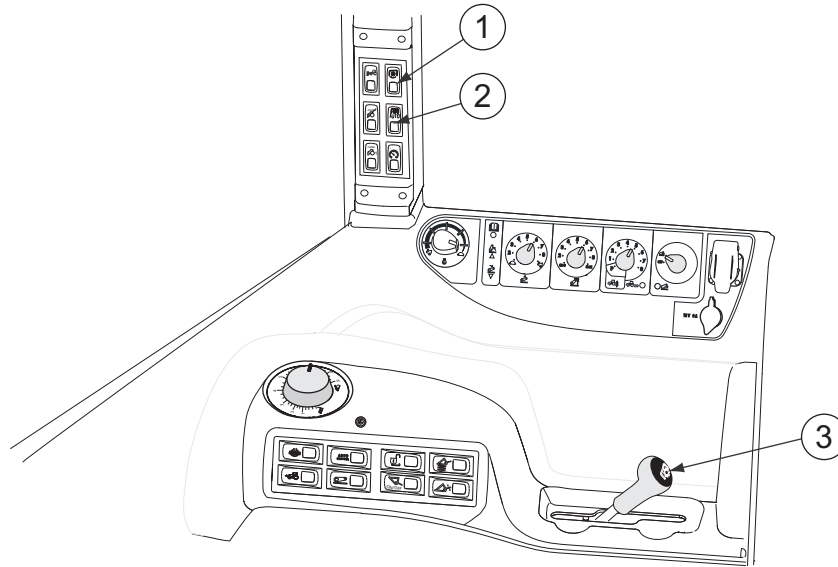

1. Switch for rear power take-off (PTO)
The rear PTO push buttons on the mudguards are extra equipment.
2. Switch for the rear PTO automatic stop (extra equipment)
3. Speed control lever for the rear PTO

Front power take-off

Front power take-off (PTO) is extra equipment.

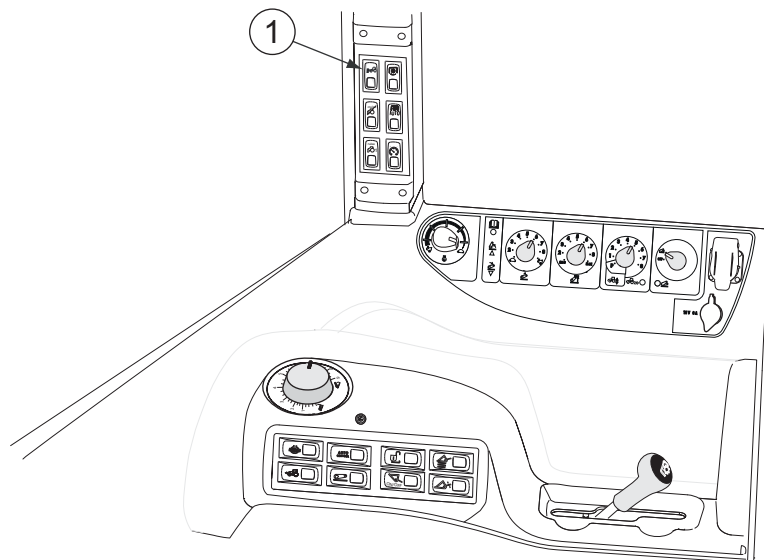

1. Switch for front PTO

2.3.4 Auxiliary hydraulics

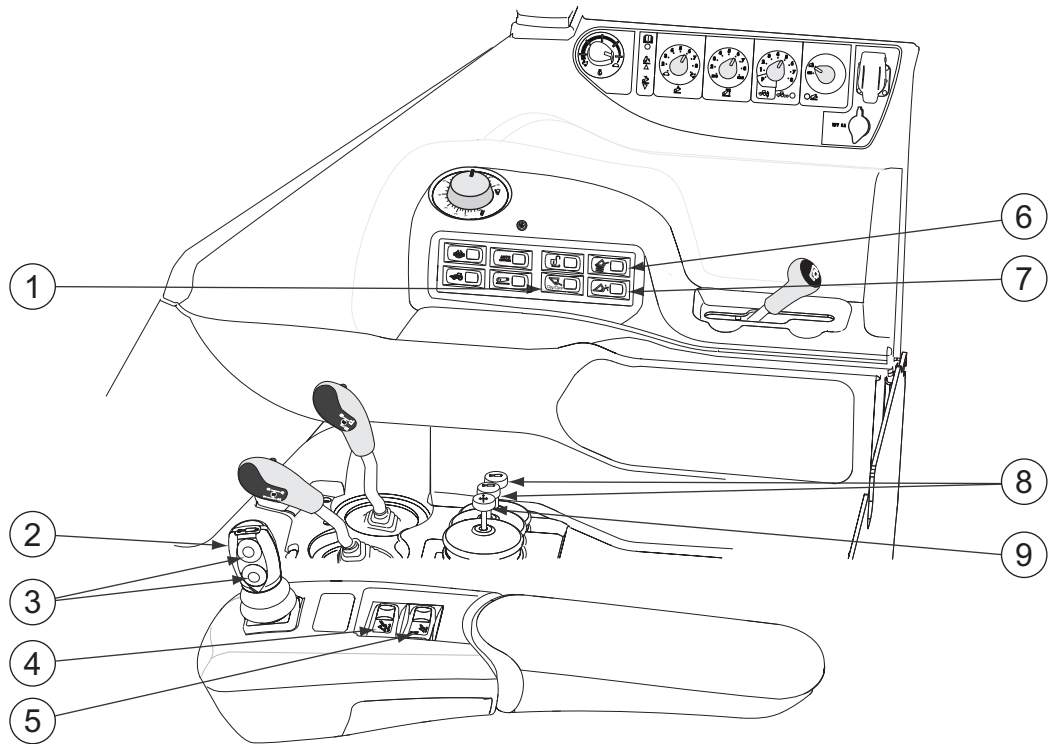

1. Front loader hydraulics On/Off switch
The armrest with front loader hydraulics controls is extra equipment.
2. Joystick
3. Joystick push buttons
4. Switch for continuous floating position
5. Switch for floating position activation
6. Switch for Softdrive (extra equipment)
7. Switch for equipment locking (extra equipment)
8. Control levers for the auxiliary hydraulics rear valves 3 and 4 (extra equipment)
9. Control lever for the auxiliary hydraulics rear valves 1 and 2

2.3.5 Other controls

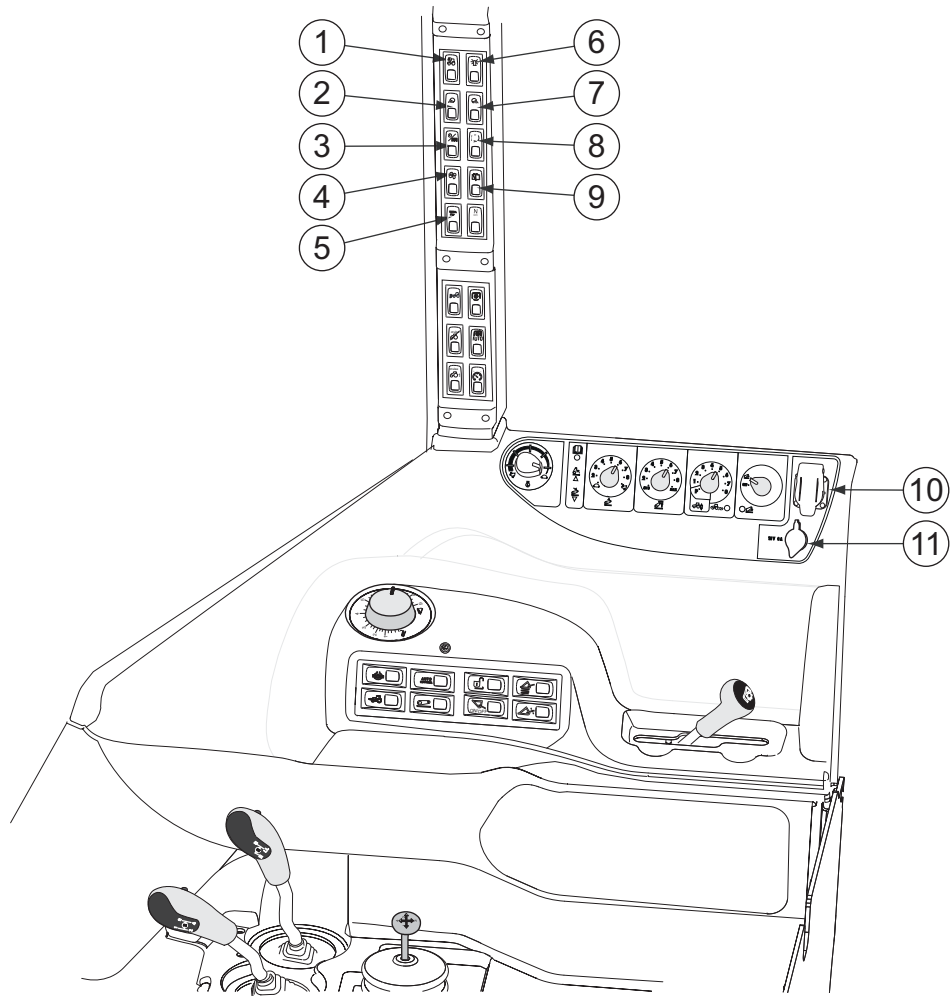

1. Switch for upper headlights (extra equipment)
2. Switch for front working lights (extra equipment)
3. Proline instrument panel display change-over switch (extra equipment)
4. Switch for heater fan
5. Switch for control stop (extra equipment)
6. Switch for rotating warning light (extra equipment)
7. Switch for rear working lights
8. Proline instrument panel display setting switch (extra equipment)
9. Switch for rear window wiper and washer (extra equipment)
10. Three-pin power socket
11. Two-pin power socket (extra equipment)

2.4 Controls on the rear side

2.4.1 Rear window opening device

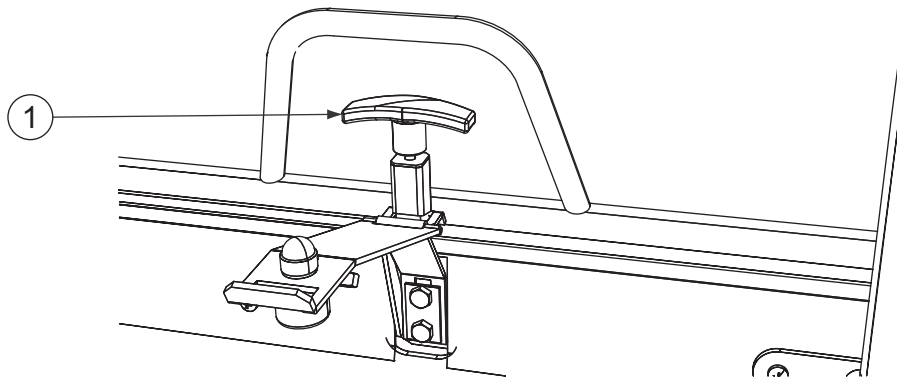

1. Rear window opening device

2.5 Controls on the left-hand side

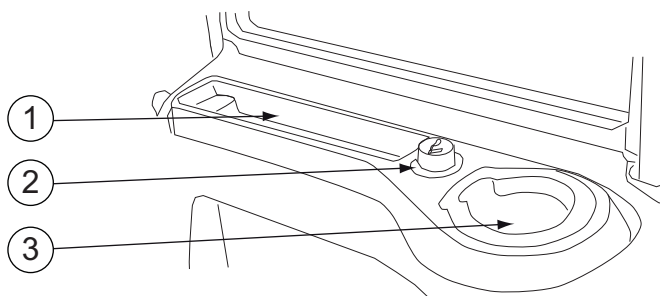

1. Storage compartment
2. Lighter
3. Cup holder

2.6 Controls on the front roof console

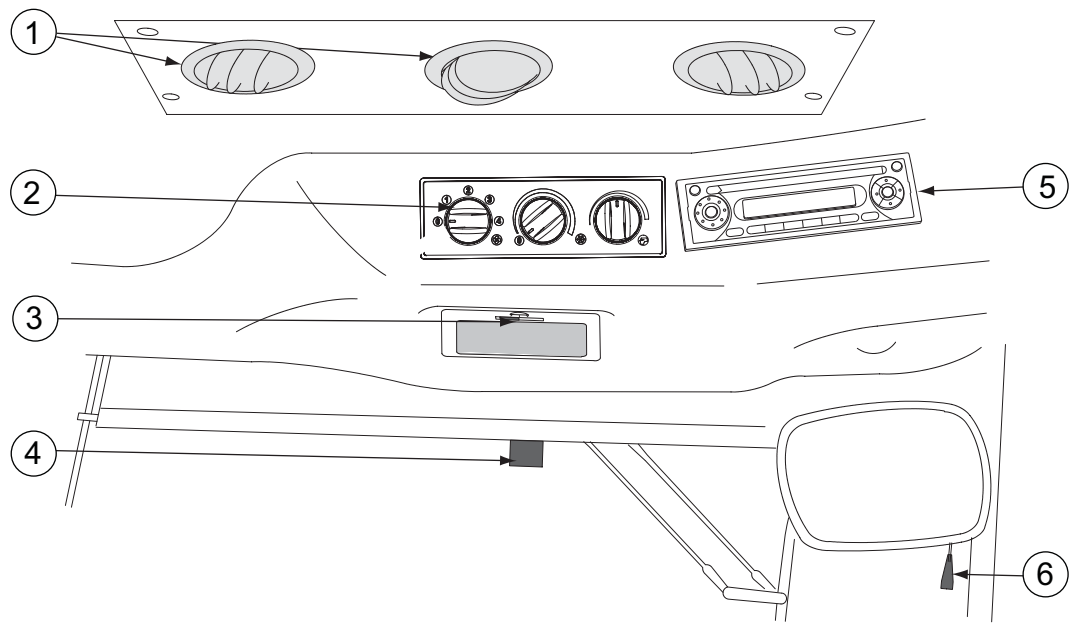

1. Ventilation nozzles (extra equipment)
2. Fan control knob (extra equipment)
3. Cab light
4. Sun visor down
5. Radio (extra equipment)
6. Sun visor up

2.7 Air conditioning controls

2.7.1 Manual air conditioning controls

The manual air conditioning system is extra equipment.

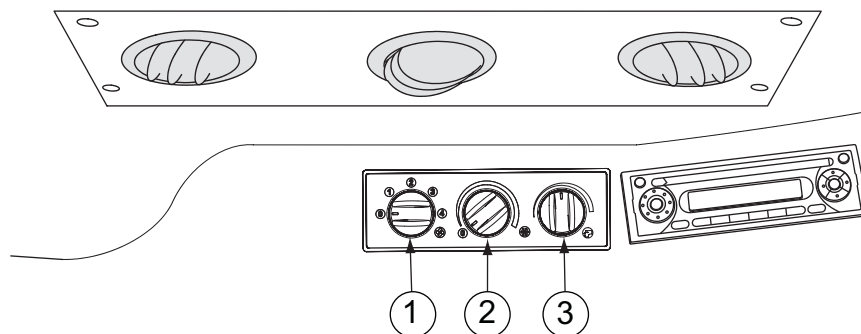

1. Fan control knob
2. Air conditioning control knob
3. Recirculation control knob