



BARBER-GREENE®

A Division of Caterpillar Paving Products Inc.

Parts Manual



**MODEL
BG-220B
ASPHALT PAVER**

HOW TO ORDER PARTS

To insure Accuracy and Promptness in Filling Your Order, the Following Must Be Given:

1. Your order number
2. Type and model number of machine for which Parts are being ordered
(If ordering for more than one machine, group the Parts for each machine and give the corresponding machine serial number.)
3. YOUR MACHINE SERIAL NUMBER (See illustration below)
4. Part Numbers
5. Description of Parts
6. Quantity of each item needed
7. Name of sub-assembly where part is to be used (For example:
Part of main transmission)
8. State whether to ship by freight, truck, UPS, parcel post, or air
9. Name and address of person or company to whom Parts are to be shipped
10. Name and address of person or company to whom invoice is to be sent
11. Shipments are collect unless otherwise specified.

To insure accuracy and promptness in filling your order, the Serial Number shown on the plate illustrated below, must be given when ordering Parts.

			
MODEL NUMBER	NUMBER		ARRANGMENT NUMBER
MACHINE	P I N		
SERIAL			
ENGINE			
CATERPILLAR INC. PEORIA, IL. MADE IN UNITED STATES OF AMERICA			

ASSEMBLIES & KITS — INDENTURES

Assemblies and kits are shown with their component parts listed directly below them. The description of the component parts is indented. All the indented parts will be furnished if the assembly or kit part number is called for. If individual part(s) of the assembly or kit is desired, order each by its part number.

IMPORTANT

READ THIS PAGE BEFORE ORDERING!!

This Manual's **Table of Contents** has been edited to agree with the serial number that appears on the front cover. The Bills of Material that have a check mark (✓) in front of them are the **ONLY** Bills of Material which apply to that machine. **DO NOT** order from a Bill of Material that **DOES NOT** have a check mark in front of it.

Many of the pages in this manual contain notes which have been added to assist in the correct identification and ordering of parts. **BE SURE** to read **ALL** notes that appear on any page from which you are ordering. (See example page below)

1. **Bill of Material:** This number designates a complete Bill of Material which includes all items listed below it. Before ordering, consult the **Table of Contents** to verify you are ordering from the proper Bill of Material.
2. **Reference Key Symbols:** Used to identify and locate parts on an illustration.
3. **Notes:** Provide additional information on a given part number.
4. **Footnote Designations:** Used to indicate specific information regarding a given part number.
5. **Indentions:** Used to indicate parts contained within an assembled unit.
6. **Footnotes:** Contain special instructions in regard to ordering parts.

TRACTOR HYDRAULICS

1 → A-876-0000B B-876-0000B

(Before Ordering, Consult Table of Contents to Verify Proper Bill of Material Number.)

REF.	PART NUMBER	QTY.	DESCRIPTION
------	-------------	------	-------------

A-876-0000B ONLY

2 → Ref #1 thru #3 Symbolized by  on Illustration in Sect. 10 Pg. 1.

1	27R25	2	Cylinder, Hydraulic (Steering) (Each Cylinder Consisting in part of the following indented item):
	27R25C1	1	• Kit, Seal
2 ^a	26N93	1	Cylinder, Hydraulic (Hopper)
3	14T50	1	Elbow, 45°, 1-5/8"-12 Str. Thd. x 1-1/4" Tube

B-876-0000B ONLY

4 → Ref. #14 thru #17 Symbolized by  on Illustration in Sect. 10 Pg. 1

14 ^b	50N75	1	Hose, Low Pressure Hydraulic, 1-1/2" x 90"
15	26J92	1	Motor, Hydraulic (Propel) (See Section 12 For Breakdown)
16	26Y96	1	Filter, Hydraulic (Consisting in part of the following indented item):
	26Y97	1	• Element, Filter
17	23R13	1	Elbow, 90°, 1/2" Tube x 7/8"-14 Str. Thd.

- a - NOTE: Consult Barber-Greene Repair Parts Department for repairs on this item.
 b - IMPORTANT - Be sure to specify length when ordering.

Entered with sales to the distributor on or after October 1, 1992

Barber-Greene Warranty

New Machines And New And Remanufactured Service Parts

Barber-Greene, A Division of Caterpillar Paving Products Inc., warrants all new machines and new and remanufactured service parts sold by it to be free from defects in material and workmanship.

This warranty is subject to the following:

Warranty Period The warranty period is 6 months, starting from date of delivery to the first user.

Barber-Greene Responsibilities: If a defect in material or workmanship is found during the warranty period, Barber-Greene will, during normal working hours and at a place of business of a Barber-Greene dealer or other authorized source:

- Provide for Barber-Greene's choice of new, remanufactured or Barber-Greene approved parts or assembled component parts needed to correct the defect.
- Note: Items replaced under warranty become the property of Barber-Greene.
- Replace lubricating oil, filters, antifreeze and other service items made unusable by the defect.
- Provide labor needed to correct defects in machines subject to this warranty.
- In the case of electrical service parts, no labor is provided.

NEITHER THE FOREGOING EXPRESS WARRANTY NOR ANY OTHER WARRANTY BY BARBER-GREENE, EXPRESS OR IMPLIED, IS APPLICABLE TO ANY ITEM BARBER-GREENE SELLS WHICH IS WARRANTED DIRECTLY TO THE USER BY ITS MANUFACTURER.

- The user is responsible for:
 - The costs associated with transporting the machine.
 - Labor costs, except as stated under "Barber-Greene Responsibilities."
 - Local taxes, if applicable.
 - Parts shipping charges in excess of those which are normal and customary.
 - Costs to investigate complaints, unless the problem is caused by a defect in Barber-Greene material or workmanship.
 - Giving timely notice of a warrantable item and promptly making the product available for repair.
 - Performance of the required maintenance and use of proper lube, oil, lubricants and coolant.

Limitations:

- Barber-Greene is not responsible for balance, residual, loan
- Any use or installation which Barber-Greene deems improper.
- Attachments, accessories items and parts not sold by Barber-Greene.
- Abuse, neglect, improper operation, repair.
- User's unreasonable delay in making the machine available which being notified of a potential product problem.

THIS WARRANTY IS EXPRESSLY IN LIEU OF ANY OTHER WARRANTIES, EXPRESS OR IMPLIED, INCLUDING ANY WARRANTY OF MERCHANTABILITY OR FITNESS FOR A PARTICULAR PURPOSE. REMEDIES UNDER THIS WARRANTY ARE LIMITED TO THE PROVISION OF MATERIAL AND LABOR, AS SPECIFIED HEREIN. BARBER-GREENE IS NOT RESPONSIBLE FOR INCIDENTAL OR CONSEQUENTIAL DAMAGES.

MODEL BG-220B ASPHALT PAVER

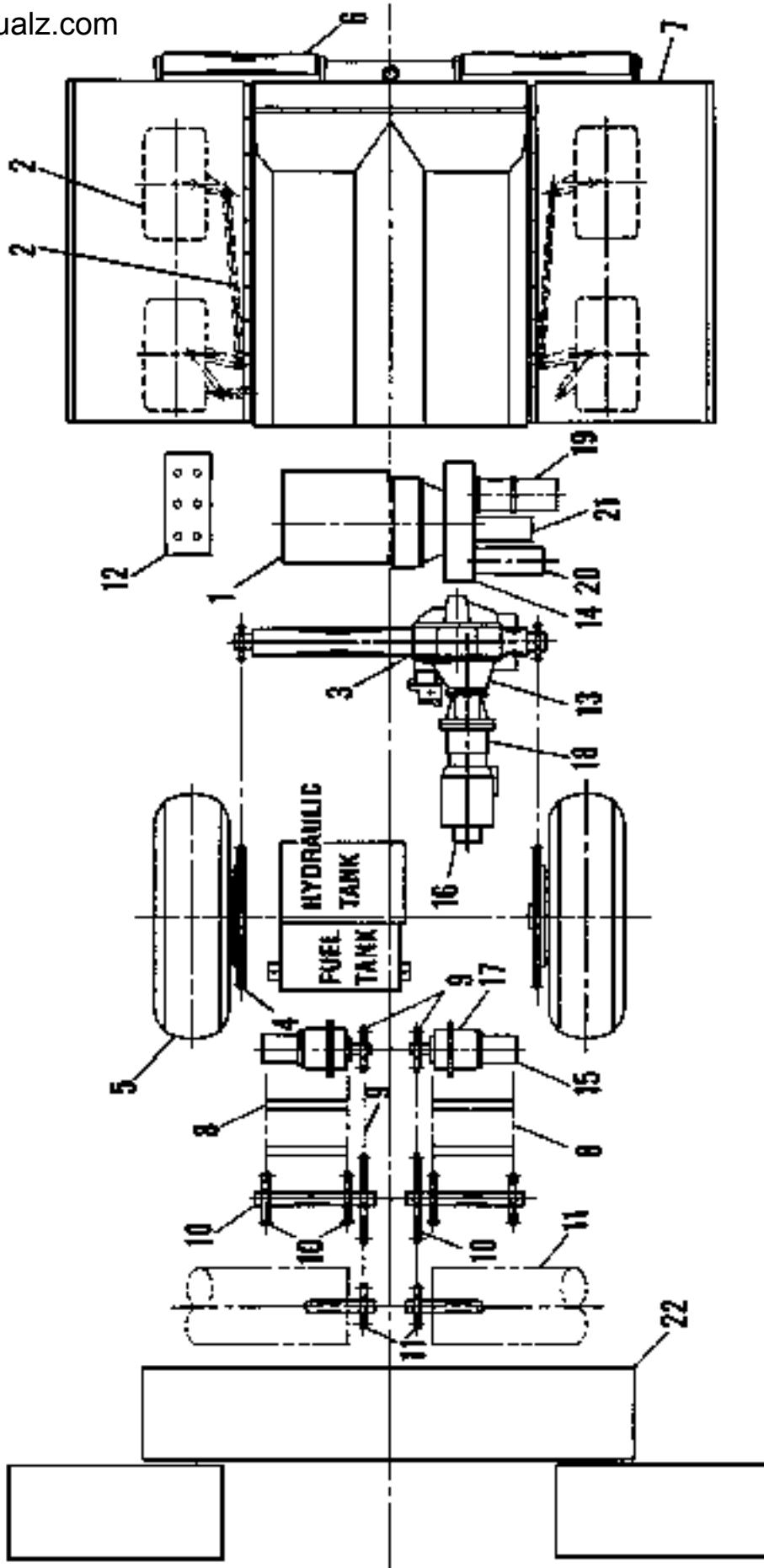

BG-220B ASPHALT PAVER

TABLE OF CONTENTS

(Note: Only Bills of Material which apply to Serial Number BG220B are checked () marked. Order parts from checked () marked Bills of Material only. All other Bills of Material do not apply to this machine serial number.)

REF.	BILL OF MATERIAL	SECT.	PG.	DESCRIPTION
-------------	-------------------------	--------------	------------	--------------------

SECTION 1 POWER UNIT & ACCESSORIES

	() A1-876-5425B	1	34	Control, Throttle
	() B1-876-5300B	1	30	Cover, Engine (For John Deere Engines)
	() B2-876-5300B	1	30	Cover, Engine (For John Deere Engines)
	() C2-876-5300B	1	31	Cover, Engine (For John Deere Engines)
	() C3-876-5300B	1	31	Cover, Engine (For John Deere Engines)
	() C4-876-5300B	1	32	Cover, Engine (For John Deere Engines)
1	() C1-876-5420B	1	27	Power Unit (Detroit Diesel 3-53N)
1	() B5-876-5420B	1	21d	Power Unit (John Deere 4039TL)
1	() B6-876-5420B	1	24	Power Unit (John Deere 4039TL)
1	() B7-876-5420B	1	26c	Power Unit (John Deere 4039TL)
1	() D-876-5420B	1	7	Power Unit (John Deere 4239D)
1	() A3-876-5420B	1	10	Power Unit (John Deere 4239DL)
1	() A4-876-5420B	1	13	Power Unit (John Deere 4239DL)
1	() A5-876-5420B	1	15a	Power Unit (John Deere 4239DL)
1	() E-876-5420B	1	16	Power Unit (John Deere 4239T)
1	() B3-876-5420B	1	19	Power Unit (John Deere 4239TL)
1	() B4-876-5420B	1	21a	Power Unit (John Deere 4239TL)
1	() A2-876-5420B	1	1	Power Unit (John Deere 4276D)
1	() B2-876-5420B	1	4	Power Unit (John Deere 4276T)
	() A1-876-5475B	1	35	Tank, Fuel
	() A2-876-5475B	1	36	Tank, Fuel

REF.	BILL OF MATERIAL	SECT.	PG.	DESCRIPTION
------	------------------	-------	-----	-------------

SECTION 2 WHEEL DRIVE & BOGIE WHEELS

2	() B-876-5435B	2	12	Bogie Frame, Rear Bogie Wheels & Steering Components
2	() B1-876-5435B	2	14	Bogie Frame, Rear Bogie Wheels & Steering Components
2	() A-876-5435B	2	2	Bogie Frame, Wheel & Steering Linkage
	() D3-876-5430B	2	49	Brake, Parking & Travel
	() A-876-5430B	2	38	Drive Axle As & Sprocket (Consisting of the following indented item:
3	() A-53-2805A	2	40	• Drive Axle As
	() C-876-5435B	2	18	Front Wheel Drive Package
	() C1-876-5435B	2	24	Front Wheel Drive Package
	() C2-876-5435B	2	30	Front Wheel Drive Package
	() C3-876-5435B	2	35	Front Wheel Drive Package
2	() A1-876-5435B	2	5	Front Bogie Wheels & Steering Linkage
2	() A2-876-5435B	2	7	Front Bogie Wheels & Steering Linkage
2	() A3-876-5435B	2	9	Front Bogie Wheels & Steering Linkage
4	() B-876-5430B	2	42	Wheel, Hub & Sprocket
5	() C-876-5430B	2	43	Wheel Rim & Tire
5	() C1-876-5430B	2	44	Wheel Rim & Tire
5	() C2-876-5430B	2	45	Wheel Rim & Tire

REF.	BILL OF MATERIAL	SECT.	PG.	DESCRIPTION
-------------	-------------------------	--------------	------------	--------------------

SECTION 3 PUSH ROLLERS & TRUCK HITCH

	() G-876-5240B	3	15	Components, Truck Hitch
	() B2-876-5240B	3	7a	Components, Layton Truck Hitch
	() 103-4353	3	17	Hitch, Truck (Consisting of the following indented item):
	() 103-4354	3	19	• Assembly, Truck Hitch
	() CB-876-5240B	3	9	Hitch, Truck (Allatt)
	() F-876-5240B	3	13	Hitch, Truck (Barber-Greene)
	() B-876-5240B	3	5	Hitch, Truck (Layton)
	() B1-876-5240B	3	7	Hitch, Truck (Layton)
	() E-876-5240B	3	7b	Hitch, Truck (Layton)
	() CB1-876-5240B	3	11	Hitch, Truck (Roadtec)
6	() 112-0897	3	3b	Push Roller Ar (Consisting in part of the following indented item):
6	() 112-0896	3	3c	• Push Roller Gp
6	() A-876-5240B	3	1	Push Roller, Fixed
6	() C-876-5240B	3	2	Push Roller, Oscillating
6	() D-876-5240B	3	3	Push Roller, Weighted Oscillating
6	() BH-876-5240B	3	3a	Push Roller, Weighted Oscillating

REF.	BILL OF MATERIAL	SECT.	PG.	DESCRIPTION
-------------	-------------------------	--------------	------------	--------------------

SECTION 4 HOPPER, APRONS & FLASHING

	() C-876-5235B	4	8	Flashing, Hopper (Deluxe)
	() B-876-5235B	4	6	Flashing, Hopper (Standard)
7	() A1-876-5235B	4	2	Hopper & Aprons
7	() A2-876-5235B	4	4	Hopper & Aprons
7	() CA-876-5235B	4	4b	Hopper & Aprons

SECTION 5 FEEDER COMPONENTS

8	() J2-876-5245B	5	5	Chain, Feeder Flight (Standard Duty)
8	() K-876-5245B	5	6	Chain, Feeder Flight (Heavy Duty)
	() L1-876-5245B	5	13	Chain Guards & Wear Bars, Feeder
	() H-876-5245B	5	11	Drag Pans, Feeder
	() A1-876-5245B	5	2	Gates, Feeder
	() V-876-5245B	5	4a	Piping, Feeder Foot Shaft Grease
	() D-876-5245B	5	10	Piping, Feeder Head Shaft Grease
	() F-876-5245B	5	10	Piping, Feeder Head Shaft Grease
9	() B1-876-5245B	5	7	Planetary, Sprocket & Chain, Feeder & Screw
9	() B2-876-5245B	5	7a	Planetary, Sprocket & Chain, Feeder & Screw
	() T-876-5245B	5	3	Shaft, Foot
	() T1-876-5245B	5	4	Shaft, Foot
10	() C-876-5245B	5	8	Shaft, Head (Standard Duty)
10	() E-876-5245B	5	9	Shaft, Head (Heavy Duty)

REF.	BILL OF MATERIAL	SECT.	PG.	DESCRIPTION
------	------------------	-------	-----	-------------

SECTION 6 SCREW CONVEYOR COMPONENTS

11	() A1-876-5250B	6	2	Conveyor, Screw
	() AC-876-1965B	6	6	End Cover, Screw Conveyor Extension
	() H-876-365B	6	6	Extension, Screw Conveyor (1'-0") (Hemi)
	() J-876-365B	6	6	Extension, Screw Conveyor (2'-0") (Hemi)
	() AD-876-2560B	6	6	Extension, Screw Conveyor (0'-6") (Hemi)
	() AE-876-2560B	6	6	Extension, Screw Conveyor (0'-10") (Ni-Hard Bolt On Segments)
	() B2-876-5250B	6	3	Supports, Outer Screw Conveyor
	() B3-876-5250B	6	4	Supports, Outer Screw Conveyor
	() C-876-5250B	6	5	Support & Shaft, Screw Conveyor Bearing

SECTION 7 LEVELING ARMS, TOW POINTS & SCREED TRAVEL SUPPORT

	() A2-876-5260B	7	2	Arms, Leveling
	() A3-876-5260B	7	3	Arms, Leveling
	() A4-876-5260B	7	4	Arms, Leveling
	() A-876-5270B	7	5	Support, Screed Travel
	() A3-876-5255B	7	1	Tow Points

REF.	BILL OF MATERIAL	SECT.	PG.	DESCRIPTION
-------------	-------------------------	--------------	------------	--------------------

SECTION 8 OPERATOR STATION

()	A2-876-5490B	8	2	Operator Station & Mechanical Controls
()	A3-876-5490B	8	4	Operator Station & Mechanical Controls
()	B1-876-5490B	8	6	Operator Station & Mechanical Controls (Optional)
()	A-876-4790B	8	7	Seat, Operator (Standard)
()	B1-876-4790B	8	7	Seat, Operator (Deluxe)

SECTION 9 ELECTRICAL COMPONENTS

()	B1-876-5285B	9	17	Electrical, Automatic Grade Control
()	E-876-5485B	9	35	Electrical, Back-Up Alarm
()	E1-876-5485B	9	37	Electrical, Back-Up Alarm
()	C2-876-5285B	9	19	Electrical, Feeder (On-Off)
()	C3-876-5285B	9	20	Electrical, Feeder (On-Off)
()	D2-876-5285B	9	21	Electrical, Feeder (Proportional)
()	CA-876-5285B	9	23	Electrical, Feeder (Proportional) {Sonic Feeder Control}
()	CA1-876-5285B	9	25	Electrical, Feeder (Proportional) {Sonic Feeder Control}
()	CA2-876-5285B	9	27	Electrical, Feeder (Proportional) {Sonic Feeder Control}
()	CB-876-5285B	9	29	Electrical, Feeder (Proportional) {Sonic Feeder Control}
()	CB1-876-5285B	9	31	Electrical, Feeder (Proportional) {Sonic Feeder Control}
()	CB2-876-5285B	9	33	Electrical, Feeder (Proportional) {Sonic Feeder Control}

REF.	BILL OF MATERIAL	SECT.	PG.	DESCRIPTION
------	------------------	-------	-----	-------------

SECTION 9 ELECTRICAL COMPONENTS (Continued)

12	() A2-876-5485B	9	2	Electrical, Tractor (Consisting of the following indented items):
	() SA-876-5487W	9	13	• Instrument Panel & Harness
	() XA-876-5487W	9	7	• Junction Box (Left Side)
	() XB-876-5487W	9	9	• Junction Box (Right Side)
	() VA-876-5487W	9	11	• Operator Station Panel & Harness (Right Side)
12	() A3-876-5485B	9	5	Electrical, Tractor (Consisting of the following indented items):
	() SA-876-5487W	9	13	• Instrument Panel & Harness
	() XA1-876-5487W	9	8	• Junction Box (Left Side)
	() XB1-876-5487W	9	10	• Junction Box (Right Side)
	() VA-876-5487W	9	11	• Operator Station Panel & Harness (Right Side)
12	() A4-876-5485B	9	6b	Electrical, Tractor (Consisting of the following indented items):
	() SA1-876-5487W	9	13b	• Instrument Panel & Harness
	() XA1-876-5487W	9	8	• Junction Box (Left Side)
	() XB1-876-5487W	9	10	• Junction Box (Right Side)
	() VA-876-5487W	9	11	• Operator Station Panel & Harness (Right Side)

REF.	BILL OF MATERIAL	SECT.	PG.	DESCRIPTION
------	------------------	-------	-----	-------------

SECTION 9 ELECTRICAL COMPONENTS (Continued)

12	() A5-876-5485B	9	6e	Electrical, Tractor (Consisting of the following indented items):
	() SA2-876-5487W	9	13d	• Instrument Panel & Harness
	() XA1-876-5487W	9	8	• Junction Box (Left Side)
	() XB1-876-5487W	9	10	• Junction Box (Right Side)
	() VA-876-5487W	9	11	• Operator Station Panel & Harness (Right Side)
	() F-876-5285B	9	39	Lights, Paving
	() F1-876-5285B	9	41	Lights, Paving
	() G-876-5285B	9	42	Lights, Warning
	() B1-876-5485B	9	14	Operator Station Panel & Harness - Left Side - John Deere Engine (Consisting of the following indented item):
	() TA-876-5487W	9	15	• Operator Station Panel & Harness (Left Side)
	() C1-876-5485B	9	14	Operator Station Panel & Harness - Left Side - G.M.C. Power Unit (Consisting of the following indented item):
	() TA-876-5487W	9	15	• Operator Station Panel & Harness (Left Side)

REF.	BILL OF MATERIAL	SECT.	PG.	DESCRIPTION
-------------	-------------------------	--------------	------------	--------------------

SECTION 10 HYDRAULIC COMPONENTS

()	C2-876-5280B	10	70	Hydraulics, Automatic Grade Control
()	C3-876-5280B	10	72	Hydraulics, Automatic Grade Control
()	C4-876-5280B	10	74	Hydraulics, Automatic Grade Control
()	B1-876-5480B	10	66	Hydraulics, Dual Control Station
()	B2-876-5480B	10	68	Hydraulics, Dual Control Station
()	D1-876-5480B	10	64	Hydraulics, Single Control Station
()	D2-876-5480B	10	64	Hydraulics, Single Control Station
()	A3-876-5480B	10	3	Hydraulics, Tractor
()	A4-876-5480B	10	10	Hydraulics, Tractor
()	A5-876-5480B	10	17	Hydraulics, Tractor
()	A6-876-5480B	10	24	Hydraulics, Tractor
()	A7-876-5480B	10	31	Hydraulics, Tractor
()	A8-876-5480B	10	38	Hydraulics, Tractor
()	A9-876-5480B	10	45	Hydraulics, Tractor
()	A10-876-5480B	10	52	Hydraulics, Tractor
()	A12-876-5480B	10	59	Hydraulics, Tractor

SECTION 11 MISCELLANEOUS TRACTOR COMPONENTS

()	B-876-5325B	11	9	Brace, Main Frame Extension (16' - 26')
()	C-876-5325B	11	9	Extension, Tractor Main Frame (1'-0")
()	A-876-5325B	11	9	Extension, Tractor Main Frame (1'-10")
()	A-876-5500B	11	17	Fenders
()	A-876-4825B	11	5	Gauge, Steering
()	C-876-5315B	11	4q	Gauge, Steering
()	A2-876-5415B	11	8	Main Frame, Tractor
()	A3-876-5415B	11	8	Main Frame, Tractor

REF.	BILL OF MATERIAL	SECT.	PG.	DESCRIPTION
-------------	-------------------------	--------------	------------	--------------------

SECTION 11 MISCELLANEOUS TRACTOR COMPONENTS (Continued)

()	A4-876-5415B	11	8	Main Frame, Tractor
()	A5-876-5510B	11	3	Nameplates
()	A6-876-5510B	11	4c	Nameplates
()	A7-876-5510B	11	4g	Nameplates
()	A8-876-5510B	11	4k	Nameplates
()	A9-876-5510B	11	4o	Nameplates
()	E2-876-5300B	11	13	Platforms
()	E3-876-5300B	11	15	Platforms
()	A-876-5520B	11	7	Spraydown, Fuel
()	A1-876-5520B	11	7b	Spraydown, Fuel
()	B-876-5315B	11	12	Tools & Spares (Grade Control)
()	A1-876-5515B	11	11	Tools & Spares (Tractor With Standard Duty Feeder)
()	D-876-5515B	11	11	Tools & Spares (Tractor With Heavy Duty Feeder)
()	D-876-1860B	11	10	Umbrella (With Support)
()	G-876-1860B	11	10	Umbrella (With Support)
()	F-876-1860B	11	10	Umbrella

REF.	PART NUMBER	SECT.	PG.	DESCRIPTION
------	-------------	-------	-----	-------------

SECTION 12 COMPONENT BREAKDOWNS

(Note: Only Component Breakdowns which apply to this Serial Number are checked () marked. Order parts from checked () marked Component Breakdowns only. All other Component Breakdowns do not apply to this machine serial number.)

	() 28W09	12	37	Cylinder, Hydraulic (Auto Grade Control)
	() 27V85	12	3	Cylinder, Hydraulic (Hopper)
	() 28L43	12	30	Cylinder, Hydraulic (Screed Lift)
	() 28Y79	See Sect. 10		Cylinder, Hydraulic (Screed Lift)
	() 28M35	12	31	Cylinder, Hydraulic (Steering)
	() 28F39	12	16	Cylinder, Master
13	() 27X64	12	11	Differential Head Assembly
	() 28F59	12	18	Disc Brake Assembly
14	() 28P34	12	35	Gearbox, Pump Drive (Triple Pump)
15	() 28N95	12	33	Motor, Hydraulic (Feeder & Screw)
16	() 27Y30	See Sect. 10		Motor, Hydraulic (Propel)
17	() 27X04	12	5	Planetary, Feeder & Screw
18	() 27X66	12	14	Planetary, Propel (Two-Speed)
19	() 28L38	12	27	Pump, Hydraulic (Feeder & Screw) (Tandem)
19	() 28W80	See Sect. 10		Pump, Hydraulic (Feeder & Screw) (Tandem)
20	() 28G25	12	21	Pump, Hydraulic (Propel)
20	() 29N52	See Sect. 10		Pump, Hydraulic (Propel)
21	() 27X33	12	8	Pump, Hydraulic (SBS)
21	() 29P51	See Sect. 10		Pump, Hydraulic (SBS)

REF.	PART NUMBER	SECT.	PG.	DESCRIPTION
------	-------------	-------	-----	-------------

SECTION 12 COMPONENT BREAKDOWNS (Continued)

() 28L27	12	24	Shift Unit, Electric
() 15K55	12	1	Valve (SBS)
() 29R30	See Sect. 10		Valve (Screed)
() 26N60	12	2	Valve, Solenoid
() 27X16	12	6	Valve, Solenoid

AUTO GRADE CONTROL

See Separate Book

SCREED

22

See Separate Book

SECTION 1

BG-220B Asphalt Paver

POWER UNIT & ACCESSORIES

**POWER UNIT
(John Deere 4276D)**

A2-876-5420B

(Before Ordering, Consult Table of Contents to Verify Proper Bill of Material Number.)

REF.	PART NUMBER	QTY.	DESCRIPTION
	ZBN94	1	Engine, John Deere 4276D (See Separate Manual) (Consisting in part of the following commonly ordered engine components):
	DEE-AR50041	1	. Element, Fuel Filter
	28G52C2	1	. Filter, Oil
	16F71	1	Radiator
	16J18	1	Cap, Radiator - 7 P.S.I.
	FA-876-5223	1	Mount, Baffle, Oil Cooler
	EA-876-5223	1	Mount, Baffle, Oil Cooler
	CB-876-5423	1	Shroud, Fan
	BC-876-5423	1	Shroud, Fan
	16J81	20	#12-24 x 1/2" Self-Tap Screw
	15G35	1	Valve, Radiator Drain
	CA-876-5423	1	Support, Radiator (Bottom)
	AB-876-5423	1	Spacer, Fan
	13M81	4	3/8" x 1-3/4" Hex Head Cap Screw
	27L78	4	3/8" Lock Washer
	J-876-462B	4	Pad, Radiator
	15C82	2	5/16" x 1-1/4" Hex Head Cap Screw
	14Z77	2	5/16" Lock Nut
	27L54	7	5/16" Cut Washer
a	28K91	1	Hose, 1-1/2" x 12.50"
	DA-876-5222W	1	Support, Radiator (Top)
	23H32	2	Clamp, Hose
	B-876-5422W	1	Housing, Thermostat
	23V19	1	Gasket
	A-46-2180	1	Hose, Radiator (Upper)
	16L58	1	Hose, Radiator (Lower)
	23H32	4	Clamp, Hose (For Radiator Hoses)
	R-80-481W	1	Hose Assembly, 1/2" x 36" (Oil Drain)
	23LB9	1	Elbow, 90° - 1/2" O.D. Tube x 1/2" N.P.T.F.
	12T61	1	Plug, Flared Tube, 37° Type Std. - 1/2" Tube O.D.
b	14J99	1	Sending Unit, Temperature
	23D31	1	Bushing, 1/2" x 3/8" N.P.T.
	14J97	1	Sending Unit, Oil Pressure
	23X30	1	3/8" x 3" Hex Head Cap Screw
	26C50	4	5/8" x 2" Hex Head Cap Screw
	B9-876-5222W	1	Mount, Engine (Right Front)
	BA-876-5222W	1	Mount, Engine (Left Front)
	A-876-5423	2	Support, Pump Box (Rear)
	26C47	8	5/8" x 1-1/4" Hex Head Cap Screw
	27L59	8	5/8" Cut Washer
	12Z46	4	5/8" Lock Nut
	16R18	2	5/8" x 2" Stud

REF.	PART NUMBER	QTY.	DESCRIPTION
	26C48	2	5/8" x 1.50" Hex Head Cap Screw
	27L84	12	5/8" Lock Washer
	27X83	1	Bearing, Pilot
	27X79	12	3/8" x 1-1/4" Hex Head Cap Screw
	13M81	8	3/8" x 1-3/4" Hex Head Cap Screw
	27L78	20	3/8" Lock Washer
	27C98	2	5/8" Hex Nut
	NY-17-9	6	Washer, Snubbing - 9/16" I.D. x 2" O.D. x 10 Ga. Stl.
	16F90	4	Mount, Vibration (Rear)
	27V90	2	Mount, Vibration (Front)
	26A03	6	1/2" x 3-1/2" Hex Head Cap Screw
	27L58	6	1/2" Cut Washer
	12Z45	6	1/2" Lock Nut
	10E10	13	3/8" x 1-1/4" Hex Head Cap Screw
	12H23	12	3/8" Lock Nut
	27L56	15	3/8" Cut Washer
	A-876-5222W	1	Stl, Engine
	15Y18	1	Muffler
	20V15	2	Clamp Half, Muffler
	20V14	1	Gasket, Flange Exhaust
	EB-876-5223	1	Baffle, Top Cooler
	13J31	4	1/4" x 3/4" Hex Head Cap Screw
	27C86	4	1/4" Nut
	27L76	4	1/4" Lock Washer
	27L52	4	1/4" Cut Washer
	13M81	1	3/8" x 1.75" Hex Head Cap Screw
	27C90	2	3/8" Nut
	27L78	4	3/8" Lock Washer
	26C53	1	3/8" x 1" Hex Head Cap Screw
	31K70	1	Cap, Rain
	28J67	1	Pipe, Exhaust
	15Y81	1	Clamp
	23V67	1	5/16" x 1" Hex Head Cap Screw
	20X06	4	5/16" x 1-1/2" Hex Head Cap Screw
	27C87	4	5/16" Nut
	27L77	7	5/16" Lock Washer
	12X06	1	Switch, Engine Kill (Mounted on Operators Station Panel)
	27V87	1	Alternator
	12S67	1	Sheave
	A-876-5228	1	Bracket, Throttle Cable
	28F21	1	Tower (For Alternator)
	28F31	1	Terminal, Female (For Alternator)
	28F32	1	Seal, Cable (For Alternator)
	MA-876-5287W	1	Cable, Battery (Positive)
	27C90	1	3/8" Hex Nut
	GF-876-5287W	1	Wire, Jumper
	27L78	1	3/8" Lock Washer
	26C97	1	3/8" External Tooth Lock Washer
	XA-876-5287W	1	Harness, Starter
	XC-876-5287W	1	Harness, Engine

REF.	PART NUMBER	QTY.	DESCRIPTION
a	14L31	1	Hose, 1/4" I.D. x 15'-0"
	23D49	2	Connector, 1/4" I.D. Tube x 1/4" O.D. Tube
	23C18	1	Elbow, 90° - 1/4" O.D. Tube x 1/4" N.P.T.
	20N41	4	Clamp, Hose
	23D29	2	Bushing, 3/8" x 1/4" N.P.T.
	23F08	1	Elbow, 90° - 1/4" O.D. Tube x 1/8" N.P.T.
	DD-876-5223	1	Tube (Fuel Return)
	10B23	3	Strap, Cable
	28M29	1	Connector, 1/4" Male N.P.T.F. x 1/4" I.D.
	28K38	1	Wire, Sealing
	16F93	1	Cleaner, Air (Complete With Element) (Consisting in part of the following indented items):
	16F94	1	Element, Air Cleaner
	161.08	1	Band, Mounting
	24E25	2	5/16" x .75" Hex Head Cap Screw
	28N89	1	Elbow, 2.50" I.D. Rubber
	28N92	1	Connector, 2.50" x 3" Reducing
	A-46-2267	1	Elbow, 3" O.D. Tube
	14S36	1	Clamp, 3" Exhaust
	28N88	1	Elbow, 3" x 3.50" Rubber
	23H35	1	Clamp
	23H34	3	Clamp
	16L10	1	Cap, Rain (For Air Cleaner)
	28P34	1	Gearbox, Pump Drive (With Clutch) (See Section 12 For Breakdown)

- a - Be sure to specify length when ordering.
- b - Servicable as a complete unit only.

**POWER UNIT
(John Deere 4276T)**

B2-876-5420B

(Before Ordering, Consult Table of Contents to Verify Proper Bill of Material Number.)

REF.	PART NUMBER	QTY.	DESCRIPTION
	16F38	1	Engine, John Deere 4276T (See Separate Manual) (Consisting in part of the following commonly ordered engine components):
	DEE-AR50041	1	. Element, Fuel Filter
	28G52C2	1	. Filter, Oil
	16F71	1	Radiator
	16J18	1	Cap, Radiator, - 7 P.S.I.
	FA-876-5223	1	Mount, Baffle, Oil Cooler
	FA-876-5223	1	Mount, Baffle, Oil Cooler
	A-46-2129W	1	Shroud, Fan
	16J81	10	#12-24 x .50" Self-Tapping Screw
	15G35	1	Valve, Drain
	GA-876-5223	1	Support, Bottom
	J-876-4628	4	Pad, Radiator
	15C82	4	5/16" x 1.25" Hex Head Cap Screw
	14Z77	4	5/16" Hex Nut
	27L54	5	5/16" Lock Washer
	27C87	1	5/16" Hex Nut
	27L77	1	5/16" Lock Washer
	N-876-4628	1	Support, Radiator (Top)
	H-876-4628	1	Bracket, Water Pump
	26C53	7	3/8" x 1.00" Hex Head Cap Screw
	27C90	5	3/8" Hex Nut
	27L78	10	3/8" Lock Washer
	23Y18	1	5/16" x 2.00" Hex Head Cap Screw
	26N71	2	Guard, Fan
□	28N83	1	Fan
	28N84	1	Spacer, Fan
	10V14	4	3/8" x 1.50" Hex Head Cap Screw
	27L78	4	3/8" Lock Washer
	11N32	2	3/8" x 2" Hex Head Cap Screw
	B-3-4608	1	Cover, Thermostat Housing
	23V19	1	Gasket
	23V18	1	Hose, Radiator (Top)
	28K99	1	Hose, Radiator (Bottom)
	23H32	3	Clump, Hose
	23H33	1	Clamp, Hose
	27L56	7	3/8" Cut Washer
	EB-876-5223	1	Baffle, Top Cooler
	13J31	4	1/4" x .75" Hex Head Cap Screw
	27C86	4	1/4" Hex Nut
	27L76	4	1/4" Lock Washer
	27L52	4	1/4" Cut Washer
	A1-80-481W	1	Hose Assembly, 1/2" x 28" (Oil Drain)

REF.	PART NUMBER	QTY.	DESCRIPTION
	23R13	1	Elbow, 90° - 1/2" O.D. Tube x 7/8"-14 Str. Thd. (Body Only)
	12T61	1	Plug, Flared Tube, 37° Type Stl., 1/2" Tube O.D.
	BB-876-5222W	1	Mount, Engine (Right Front)
	BA-876-5222W	1	Mount, Engine (Left Front)
	A-876-5423	2	Support, Pump Box (Rear)
	26C47	8	5/8" x 1.25" Hex Head Cap Screw
	27L59	8	5/8" Cut Washer
	12Z46	4	5/8" Lock Nut
	16R10	2	5/8" x 2.00" Stud
	26C50	4	5/8" x 2" Hex Head Cap Screw
	27L84	12	5/8" Lock Washer
	27X83	1	Bearing, Pilot
	27X79	12	3/8" x 1.25" Ferry Head Cap Screw
	13M81	8	3/8" x 1.75" Hex Head Cap Screw (Grade 8)
	27L78	20	3/8" Lock Washer
	26C48	2	5/8" x 1.50" Hex Head Cap Screw
	NV-17-9	6	Washer, Snubbing - 9/16" I.D. x 2" O.D. x 10 Ga. Stl.
	16F90	4	Mount, Vibration (Rear)
	27V90	2	Mount, Vibration (Front)
	26A03	6	1/2" x 3.50" Hex Head Cap Screw
	27L58	6	1/2" Cut Washer
	12Z45	6	1/2" Lock Nut
	10E10	12	3/8" x 1.25" Hex Head Cap Screw
	12H23	12	3/8" Lock Nut
	27C98	2	5/8" Hex Nut
	A-876-5222W	1	Sill, Engine
	27L56	12	3/8" Cut Washer
a	A-876-4768	1	Bracket, Throttle Cable
	14J99	1	Sending Unit, Temperature
	23D31	1	Bushing, 1/2" x 3/8" N.P.T.
	14J97	1	Sending Unit, Oil Pressure
	16L02	1	Alternator, 55 Amp.
	23H35	2	Clamp, Worm Drive
	16F93	1	Cleaner, Air (Complete With Element) (Consisting in part of the following indented item):
	16F94	1	- Element, Air Cleaner
	16L08	1	Band, Mounting
	26E25	2	5/16" x .75" Hex Head Cap Screw
	27C87	2	5/16" Nut
	27L77	2	5/16" Lock Washer
	28N91	1	Elbow, Molded - 45° x 3" I.D.
	28N90	1	Elbow, Molded - 45° x 3" I.D.
	23H34	1	Clamp, Worm Drive
	16L10	1	Cap, Air Cleaner
	7D-876-5223	1	Tubing, 3" O.D. x 1.5
	10B23	3	Strap, Cable
	12X06	1	Switch, Engine Kill (Located on Operators Panel)
b	14L31	1	Hose, 1/4" I.D. x 13'-0"
	23M29	1	Connector, 1/4" Male N.P.T.F. x 1/4" I.D.
	23C49	2	Connector, 1/4" I.D. Hose x 1/4" O.D. Tube

REF.	PART NUMBER	QTY.	DESCRIPTION
	23C18	1	Elbow, 90°, 1/4" O.D. Tube x 1/4" N.P.T.
	20N41	4	Clamp, Hose
	23D29	2	Bushing, 3/8" x 1/4" N.P.T.
	23F08	1	Elbow, 90° - 1/4" T. x 1/8" N.P.T.F.
	DD-876-5223	1	Tube x 1/4"
	16F92	1	Muffler, Wrapped
	AG-876-462B	1	Stack, Exhaust
	31K69	1	Cap, Rain
	14S36	2	Clamp, 3"
	16G65	1	Reducer
	13N60	1	Clamp, 4"
	3A-876-5223	1	Support, Muffler (Lower)
	H-3-675	1	Collar
	BC-876-5222W	1	Support, Muffler (Upper)
	AC-876-462B	1	Strap
	13M69	1	1/4" x 1.50" Hex Head Cap Screw
	1DE10	2	3/8" x 1.25" Hex Head Cap Screw
	27L56	1	3/8" Cut Washer
	28F21	1	Tower (For Alternator)
	28F31	1	Terminal, Female (For Alternator)
	28F32	1	Seal, Cable (For Alternator)
	27L76	1	1/4" Lock Washer
	MA-876-5287W	1	Cable, Battery (Positive)
	27C86	1	1/4" Hex Nut
	GF-876-5287W	1	Wire, Jumper
	27C90	2	3/8" Hex Nut
	27L78	2	3/8" Lock Washer
	26C97	1	3/8" External Tooth Lock Washer
	XA-876-5287W	1	Harness, Starter
	XC-876-5287W	1	Harness, Engine
	DB-876-5222W	1	Support, Filter
	BB-876-5223	1	Bracket, Dipstick
b	28K91	1	Hose, 1-1/2" I.D. x 16"
	23H32	2	Clamp, Hose
	26C53	1	3/8" x 1" Hex Head Cap Screw
	26E28	1	1/2" x 1.25" Hex Head Cap Screw
	27L58	1	1/2" Cut Washer
	27L81	1	1/2" Lock Washer
	23X30	1	3/8" x 3" Hex Head Cap Screw
	27C90	2	3/8" Hex Nut
	27L78	2	3/8" Lock Washer
	23V67	1	5/16" x 1" Hex Head Cap Screw
	27L54	1	5/16" Cut Washer
	27L77	1	5/16" Lock Washer
	28P34	1	Gear Box, Pump Drive (With Clutch) (See Section 12 For Breakdown)

a - Serviceable as a complete unit only.

b - Be sure to specify length when ordering.

**POWER UNIT
(John Deere 4239D)**

D-876-5420B

(Before Ordering, Consult Table of Contents to Verify Proper Bill of Material Number.)

REF.	PART NUMBER	QTY.	DESCRIPTION
	28W84	1	Engine, John Deere 4239D (See Separate Manual)
	28W10	1	Fan, 18" Diameter (Seven Blade)
	28W11	1	Shroud, Fan
	29T52	1	Radiator
	27L58	2	1/2" Cut Washer
	12745	2	1/2" Lock Nut
	B-876-5422W	1	Housing, Thermostat
	23V19	1	Gasket
	S-876-4628	1	Plate, Water Pump
	15G35	1	Valve, Radiator Drain
	8D-876-5283	4	Strap, Rubber
	28W05	1	Spacer, Fan
	17K18	4	3/8" x 3" Hex Head Cap Screw
	27L78	4	3/9" Lock Washer
	H-876-4628	1	Bracket, Water Pump
	20G13	1	Switch, Pressure (For Hour Meter)
	J-876-4628	10	Pad, Radiator
	15C82	2	5/16" x 1-1/4" Hex Head Cap Screw
	14Z77	2	5/16" Lock Nut
	27L54	7	5/16" Cut Washer
	P-876-4628	1	Support, Radiator (Top)
	PE-876-5223	1	Pipe, Water (Lower Radiator)
	16L58	1	Hose, Radiator (Upper)
	27X30	2	Hose, Radiator (Lower)
	23H32	6	Clamp, Hose
	R-80-481W	1	Hose Assembly, 1/2" x 36" (Oil Drain)
	23L89	1	Elbow, 90° - 1/2" O.D. Tube x 1/2" N.P.T.F.
	12T61	1	Plug, Flared Tube, 37° Type Stl. - 1/2" Tube O.D.
a	14J99	1	Sending Unit, Temperature
	23D31	1	Bushing, 1/2" x 3/8" N.P.T.
	14J97	1	Sending Unit, Oil Pressure
	14T41	1	Tee, 1/8" M. x 1/8" Fe. x 1/8" Fc. N.P.T.F. Brass
	23X30	1	3/8" x 3" Hex Head Cap Screw
	26C50	4	5/8" x 2" Hex Head Cap Screw
	JB-876-5222W	1	Mount, Engine (Right Front)
	JA-876-5222W	1	Mount, Engine (Left Front)
	A-876-5423	2	Support, Pump Box (Rear)
	26C47	8	5/8" x 1-1/4" Hex Head Cap Screw
	27L59	8	5/8" Cut Washer
	12Z46	4	5/8" Lock Nut
	16R10	2	Stud, 5/8" x 2"
	26C48	2	5/8" x 1.50" Hex Head Cap Screw
	27L84	12	5/8" Lock Washer

REF.	PART NUMBER	QTY.	DESCRIPTION
	28P34	1	Gearbox, Pump Drive (With Clutch) (See Section 12 For Breakdown)
	27X93	1	Bearing, Pilot
	27X79	12	3/8" x 1-1/4" Ferry Head Cap Screw
	13M81	8	3/8" x 1-3/4" Hex Head Cap Screw
	27L78	20	3/8" Lock Washer
	27C98	2	5/8" Hex Nut
	28N95	1	Shim, 1/8" (For Pilot Bearing)
	NV-17-9	6	Washer, Snubbing - 9/16" I.D. x 2" O.D. x 10 Ga. Stl.
	16F90	4	Mount, Vibration (Rear)
	27V90	2	Mount, Vibration (Front)
	26A03	6	1/2" x 3-1/2" Hex Head Cap Screw
	27L58	6	1/2" Cut Washer
	12Z45	6	1/2" Lock Nut
	13E10	13	3/8" x 1-1/4" Hex Head Cap Screw
	12H23	12	3/8" Lock Nut
	27L56	15	3/8" Cut Washer
	A-876-5222W	1	Sill, Engine
	15Y18	1	Muffler
	20V15	2	Clamp Half, Muffler
	20V14	1	Gasket, Flange Exhaust
	DB-876-5224	1	Elbow, Air Cleaner
	16X63	1	Hose, 3" I.D. x 18.50"
	DC-876-5224	1	Connecting Sleeve, 2.50" O.D.
	EB-876-5223	1	Baffle, Top Cooler
	13J31	4	1/4" x 3/4" Hex Head Cap Screw
	27C86	4	1/4" Nut
	27L76	4	1/4" Lock Washer
	27L52	4	1/4" Cut Washer
	13M81	1	3/8" x 1.75" Hex Head Cap Screw
	27C90	2	3/8" Nut
	27L78	4	3/8" Lock Washer
	26C53	1	3/8" x 1" Hex Head Cap Screw
	31K70	1	Cap, Rain
	28J07	1	Pipe, Exhaust
	15Y81	1	Clamp
	23V67	1	5/16" x 1" Hex Head Cap Screw
	20X06	4	5/16" x 1-1/2" Hex Head Cap Screw
	27C87	4	5/16" Nut
	27L77	7	5/16" Lock Washer
	12X06	1	Switch, Engine Kill (Mounted on Operators Station Panel)
	27V97	1	Alternator
	12S67	1	Sheave
	A-876-5223	1	Bracket, Throttle Cable
	28F21	1	Tower (For Alternator)
	28F31	1	Terminal, Female (For Alternator)
	28F32	1	Seal, Cable (For Alternator)
	MA-876-5287W	1	Cable, Battery (Positive)
	27C90	1	3/8" Hex Nut

REF.	PART NUMBER	QTY.	DESCRIPTION
	GF-876-5287W	1	Wire, Jumper
	27L78	1	3/8" Lock Washer
	26C97	1	3/8" External Tooth Lock Washer
	XA-876-5287W	1	Harness, Starter
	XC-876-5287W	1	Harness, Engine
b	14L31	1	Hose, 1/4" I.D. x 15'-0"
	23D49	2	Connector, 1/4" I.D. Tube x 1/4" O.D. Tube
	23C18	1	Elbow, 90° - 1/4" O.D. Tube x 1/4" N.P.T.
	20N41	4	Clamp, Hose
	23D29	2	Bushing, 3/8" x 1/16" N.P.T.
	23F08	1	Elbow, 90° - 1/4" O.D. Tube x 1/8" N.P.T.
	DD-876-5223	1	Tube (Fuel Return)
	10B23	3	Strap, Cable
	23M29	1	Connector, 1/4" Male N.P.T.F. x 1/4" I.D.
	28K38	1	Wire, Sealing
	GC-876-5222W	2	Hanger, Air Cleaner
	16F93	1	Cleaner, Air (Complete With Element) (Consisting in part of the following indented items):
	16F94	1	. Element, Air Cleaner
	16L08	1	Band, Mounting
	26F25	2	5/16" x .75" Hex Head Cap Screw
	28N89	1	Elbow, 2.50" I.D. Rubber
	A-46-2267	1	Elbow, 3" O.D. Tube
	14S36	1	Clamp, 3" Exhaust
	28N88	1	Elbow, 3" x 3.50" Rubber
	23H35	1	Clamp
	23H34	5	Clamp
	16L10	1	Cap, Rain (For Air Cleaner)
	28T18	1	Cap, Pipe

- a - Serviceable as a complete unit only.
- b - Be sure to specify length when ordering.

**POWER UNIT
(John Deere 4239DL)**

A3-876-5420B

(Before Ordering, Consult Table of Contents to Verify Proper Bill of Material Number.)

REF.	PART NUMBER	QTY.	DESCRIPTION
	28120	1	Engine, John Deere 4239DL (See Separate Manual) (Consisting in part of the following commonly ordered engine components):
	WEN-T19044	1	- Filter, Oil
	WEN-AR50041	1	- Filter, Fuel
	28W10	1	Fan, 18" Diameter (Seven Blade)
	28W11	1	Shroud, Fan
	28T52	1	Radiator
	16J18	1	Cap, Radiator - 7 P.S.I.
	27L58	2	1/2" Cut Washer
	12Z45	2	1/2" Lock Nut
	15G35	1	Valve, Radiator Drain
	BD-876-5283	4	Strap, Rubber
	28W05	1	Spacer, Fan
	12K18	4	3/8" x 3" Hex Head Cap Screw
	27L78	4	3/8" Lock Washer
	20G13	1	Switch, Pressure (For Hour Meter)
	J-876-4628	4	Pad, Radiator
	15C82	2	5/16" x 1-1/4" Hex Head Cap Screw
	14Z77	2	5/16" Lock Nut
	27L54	7	5/16" Cut Washer
a	28X91	1	Hose, 1-1/2" x 12.50"
	DA-876-5222W	1	Support, Radiator (Top)
	23H32	2	Clamp, Hose
	KA-876-5222W	1	Pipe, Water (Lower Radiator)
	23W62	1	Hose, Radiator (Lower)
	16L58	1	Hose, Radiator (Upper)
	27X30	1	Hose, Radiator (Lower)
	23H32	6	Clamp, Hose
	R-80-481W	1	Hose Assembly, 1/2" x 36" (Oil Drain)
	23I 89	1	Elbow, 90° - 1/2" O.D. Tube x 1/2" N.P.T.F.
	12T61	1	Plug, Flared Tube, 37° Type Stl. - 1/2" Tube O.D.
b	14J99	1	Sending Unit, Temperature
	23D31	1	Bushing, 1/2" x 3/8" N.P.T.
	14J97	1	Sending Unit, Oil Pressure
	14T41	1	Tee, 1/8" M. x 1/8" Fe. x 1/8" Fe. N.P.T.F. Brass
	23X30	1	3/8" x 3" Hex Head Cap Screw
	26C50	4	5/8" x 2" Hex Head Cap Screw
	JB-876-5222W	1	Mount, Engine (Right Front)
	JA-876-5222W	1	Mount, Engine (Left Front)
	A-876-5423	2	Support, Pump Box (Rear)
	26C47	8	5/8" x 1-1/4" Hex Head Cap Screw
	27L59	8	5/8" Cut Washer
	12Z46	4	5/8" Lock Nut

REF.	PART NUMBER	QTY.	DESCRIPTION
	16R10	2	Stud, 5/8" x 2"
	26C48	2	5/8" x 1.50" Hex Head Cap Screw
	27L84	12	5/8" Lock Washer
	28P34	1	Gearbox, Pump Drive (With Clutch) (See Section 12 For Breakdown)
	27X83	1	Bearing, Pilot
	27X79	12	3/8" x 1-1/4" Ferry Head Cap Screw
	13M81	8	3/8" x 1-3/4" Hex Head Cap Screw
	27L78	20	3/8" Lock Washer
	27C98	2	5/8" Hex Nut
	NV-17-9	6	Washer, Snubbing - 9/16" I.D. x 2" O.D. x 10 Ga. 5tl.
	16F91	4	Mount, Vibration (Rear)
	27V90	2	Mount, Vibration (Front)
	26A03	6	1/2" x 3-1/2" Hex Head Cap Screw
	27L58	6	1/2" Cut Washer
	12Z45	6	1/2" Lock Nut
	10F10	13	3/8" x 1-1/4" Hex Head Cap Screw
	12H73	12	3/8" Lock Nut
	27L56	15	3/8" Cut Washer
	A-876-5222W	1	Sill, Engine
	15Y18	1	Muffler
	20V15	2	Clamp Half, Muffler
	20V14	1	Gasket, Flange Exhaust
	EB-876-5223	1	Baffle, Top Cooler
	13J31	4	1/4" x 3/4" Hex Head Cap Screw
	27C96	4	1/4" Nut
	27L76	4	1/4" Lock Washer
	27L52	4	1/4" Cut Washer
	13M81	1	3/8" x 1.75" Hex Head Cap Screw
	27C90	2	3/8" Nut
	27L78	4	3/8" Lock Washer
	26C53	1	3/8" x 1" Hex Head Cap Screw
	31K70	1	Cap, Rain
	28J07	1	Pipe, Exhaust
	15Y81	1	Clamp
	23V67	1	5/16" x 1" Hex Head Cap Screw
	20X06	4	5/16" x 1-1/2" Hex Head Cap Screw
	27C87	4	5/16" Nut
	27L77	7	5/16" Lock Washer
	12X06	1	Switch, Engine Kill (Mounted on Operators Station Panel)
	27V87	1	Alternator
	12S67	1	Sheave
	A-876-5228	1	Bracket, Throttle Cable
	28F21	1	Tower (For Alternator)
	28F31	1	Terminal, Female (For Alternator)
	28F32	1	Seat, Cable (For Alternator)
	MA-876-5287W	1	Cable, Battery (Positive)
	27C90	1	3/8" Hex Nut
	GF-876-5287W	1	Wire, Jumper

REF.	PART NUMBER	QTY.	DESCRIPTION
	27L78	1	3/8" Lock Washer
	26C97	1	3/8" External Tooth Lock Washer
	XA-876-5287W	1	Harness, Starter
	XC-876-5287W	1	Harness, Engine
a	14L31	1	Hose, 1/4" I.D. x 15'-0"
	23D49	2	Connector, 1/4" I.D. Tube x 1/4" O.D. Tube
	23C18	1	Elbow, 90° - 1/4" O.D. Tube x 1/4" N.P.T.
	20N41	4	Clamp, Hose
	23D29	2	Bushing, 3/8" x 1/4" N.P.T.
	23F08	1	Elbow, 90° - 1/4" O.D. Tube x 1/8" N.P.T.
	DD-876-5223	1	Tube (Fuel Return)
	10B23	3	Strap, Cable
	28M29	1	Connector, 1/4" Male N.P.T.F. x 1/4" I.D.
	28K39	1	Wire, Sealing
	VB-876-5223	2	Hanger, Air Cleaner
	16F93	1	Cleaner, Air (Complete With Element) (Consisting in part of the following indented items):
	16F94	1	• Element, Air Cleaner
	16L08	1	Band, Mounting
	26E25	2	5/16" x .75" Hex Head Cap Screw
	28N89	1	Elbow, 2.50" I.D. Rubber
	28N92	1	Connector, 2.50" x 3" Reducing
	A-46-7757	1	Elbow, 2" O.D. Tube
	14S36	1	Clamp, 3" Exhaust
	29N88	1	Elbow, 3" x 3.50" Rubber
	23H35	1	Clamp
	23H34	3	Clamp
	16L10	1	Cap, Rain (For Air Cleaner)
	28T18	1	Cap, Pipe

- a - Be sure to specify length when ordering.
- b - Serviceable as a complete unit only.

**POWER UNIT
(John Deere 4239DL)**

A4-876-5420B

(Before Ordering, Consult Table of Contents to Verify Proper Bill of Material Number.)

REF.	PART NUMBER	QTY.	DESCRIPTION
	28T20	1	Engine, John Deere 4239DL (See Separate Manual) (Consisting in part of the following commonly ordered engine components):
	WEN-T19044	1	. Filter, Oil
	WEN-AR50041	1	. Filter, Fuel
	28W10	1	Fan, 18" Diameter (Seven Blade)
	28W11	1	Shroud, Fan
	28T52	1	Radiator
	27L58	2	1/2" Cut Washer
	12745	2	1/2" Lock Nut
	C-876-5422W	1	Housing, Thermostat
	23V19	1	Gasket
	15G35	1	Valve, Radiator Drain
	BD-876-5283	4	Strap, Rubber
	28W05	1	Spacer, Fan
	23X30	4	3/8" x 3" Hex Head Cap Screw
	27L78	4	3/8" Lock Washer
	H-876-4628	1	Bracket, Water Pump
	20G13	1	Switch, Pressure (For Hour Meter)
	J-876-4628	10	Pad, Radiator
	15C82	2	5/16" x 1-1/4" Hex Head Cap Screw
	14Z77	2	5/16" Lock Nut
	27L54	7	5/16" Cut Washer
	P-876-4628	1	Support, Radiator (Top)
	NA-876-5222W	1	Pipe, Water (Lower Radiator)
	FC-876-5224	1	Hose, 1.38" I.D. x 5"
	16L58	1	Hose, Radiator (Upper)
	27X30	1	Hose, Radiator (Lower)
	23H32	6	Clamp, Hose
	R-80-481W	1	Hose Assembly, 1/2" x 36" (Oil Drain)
	23L89	1	Elbow, 90° - 1/2" O.D. Tube x 1/2" N.P.T.F.
	12T61	1	Plug, Flared Tube, 3/8" Type Std. - 1/2" Tube O.D.
a	14J99	1	Sending Unit, Temperature
	23D31	1	Bushing, 1/2" x 3/8" N.P.T.
	14J97	1	Sending Unit, Oil Pressure
	14T41	1	Tee, 1/8" M. x 1/8" Fe. x 1/8" Fe. N.P.T.F. Brass
	23X30	1	3/8" x 3" Hex Head Cap Screw
	26C50	4	5/8" x 2" Hex Head Cap Screw
	JB-876-5222W	1	Mount, Engine (Right Front)
	JA-876-5222W	1	Mount, Engine (Left Front)
	A-876-5423	2	Support, Pump Box (Rear)
	26C47	12	5/8" x 1-1/4" Hex Head Cap Screw
	27L59	8	5/8" Cut Washer
	12Z46	4	5/8" Lock Nut

REF.	PART NUMBER	QTY.	DESCRIPTION
	27L84	12	5/8" Lock Washer
	28P34	1	Gearbox, Pump Drive (With Clutch) (See Section 12 For Breakdown)
	27X83	1	Bearing, Pilot
	27X79	12	3/8" x 1-1/4" Ferry Head Cap Screw
	13M81	8	3/8" x 1-3/4" Hex Head Cap Screw
	27L78	20	3/8" Lock Washer
	28N85	1	Shim, 1/8" (For Pilot Bearing)
	NV-17-9	6	Washer, Snubbing - 9/16" I.D. x 2" O.D. x 10 Ga. Stl.
	16F90	4	Mount, Vibration (Rear)
	27V90	2	Mount, Vibration (Front)
	26A03	6	1/2" x 3-1/2" Hex Head Cap Screw
	27L58	6	1/2" Cut Washer
	12Z45	6	1/2" Lock Nut
	10E10	13	3/8" x 1-1/4" Hex Head Cap Screw
	12H23	12	3/8" Lock Nut
	27L56	15	3/8" Cut Washer
	A-876-5222W	1	Sill, Engine
	15Y18	1	Muffler
	20V15	2	Clamp Half, Muffler
	20V14	1	Gasket, Flange Exhaust
	DB-876-5224	1	Elbow, Air Cleaner
	16X63	1	Hose, 3" I.D. x 18.50"
	DC-876-5224	1	Sleeve, Connecting - 2.5" O.D.
	EB-876-5223	1	Baffle, Top Cooler
	13J31	4	1/4" x 3/4" Hex Head Cap Screw
	27C86	4	1/4" Nut
	27L76	4	1/4" Lock Washer
	27L57	4	1/4" Cut Washer
	13M81	1	3/8" x 1.75" Hex Head Cap Screw
	27C90	2	3/8" Nut
	27L78	4	3/8" Lock Washer
	26C53	1	3/8" x 1" Hex Head Cap Screw
	31K70	1	Cap, Main
	28J07	1	Pipe, Exhaust
	15Y81	1	Clamp
	23V67	1	5/16" x 1" Hex Head Cap Screw
	20X06	4	5/16" x 1-1/2" Hex Head Cap Screw
	27C87	4	5/16" Nut
	27L77	7	5/16" Lock Washer
	12X06	1	Switch, Engine Kill (Mounted on Operators Station Panel)
	27V87	1	Alternator
	12S67	1	Sheave
	A-876-5228	1	Bracket, Throttle Cable
	28F21	1	Tower (For Alternator)
	28F31	1	Terminal, Female (For Alternator)
	28F32	1	Seal, Cable (For Alternator)
	MA-876-5287W	1	Cable, Battery (Positive)
	27C90	1	3/8" Hex Nut

REF.	PART NUMBER	QTY.	DESCRIPTION
	GF-876-5287W	1	Wire, Jumper
	77L79	1	3/8" Lock Washer
	26C97	1	3/8" External Tooth Lock Washer
	XA-876-5287W	1	Harness, Starter
	XC-876-5287W	1	Harness, Engine
b	14L31	1	Hose, 1/4" I.D. x 15'-0"
	23D49	2	Connector, 1/4" I.D. Tube x 1/4" O.D. Tube
	23C18	1	Elbow, 90° - 1/4" O.D. Tube x 1/4" N.P.T.
	20N41	4	Clamp, Hose
	23D29	2	Bushing, 3/8" x 1/4" N.P.T.
	23F08	1	Elbow, 90° - 1/4" O.D. Tube x 1/8" N.P.T.
	DD-876-5223	1	Tube (Fuel Return)
	10B23	3	Strap, Cable
	23M29	1	Connector, 1/4" Male N.P.T. x 1/4" I.D.
	28K38	1	Wire, Sealing
	16F93	1	Cleaner, Air (Complete With Element) (Consisting in part of the following indented item):
	16F94	1	• Element, Air Cleaner
	16L08	1	Band, Mounting
	26E25	2	5/16" x .75" Hex Head Cap Screw
	28N89	1	Elbow, 2.50" I.D. Rubber
	A-46-2267	1	Elbow, 3" O.D. Tube
	14536	1	Clamp, 3" Exhaust
	28N88	1	Elbow, 3" x 3.50" Rubber
	23H35	1	Clamp
	23H34	5	Clamp
	16L10	1	Cap, Rain (For Air Cleaner)
	28T18	1	Cap, Pipe
	GC-876-5222W	2	Hanger, Air Cleaner
	23Y18	2	5/16" x 2" Hex Head Cap Screw
	27L54	2	5/16" Cut Washer
	27L77	2	5/16" Lock Washer
	27C87	2	5/16" Hex Nut

- a - Serviceable as a complete unit only.
b - Be sure to specify length when ordering.

**POWER UNIT
(John Deere 4239DL)**

A5-876-5420B

(Before Ordering, Consult Table of Contents to Verify Proper Bill of Material Number.)

REF.	PART NUMBER	QTY.	DESCRIPTION
	28T20	1	Engine, John Deere 4239DL (See Separate Manual) (Consisting in part of the following commonly ordered engine components):
	WEN-T19044	1	. Filter, Oil
	WEN-AR50041	1	. Filter, Fuel
	28W10	1	Fan, 18" Diameter (Seven Blade)
	28W11	1	Shroud, Fan
	28T52	1	Radiator
	27L58	2	1/2" Cut Washer
	12Z45	2	1/2" Lock Nut
	C-876-5422W	1	Housing, Thermostat
	23V19	1	Gasket
	15G35	1	Valve, Radiator Drain
	EA-876-5222W	2	Mount, Oil Cooler
	ED-876-5224	1	Baffle, Oil Cooler
	BD-876-5283	4	Strap, Rubber
	28W05	1	Spacer, Fan
	23X30	4	3/8" x 3" Hex Head Cap Screw
	27L78	4	3/8" Lock Washer
	H-876-4628	1	Bracket, Water Pump
	20G13	1	Switch, Pressure (For Hour Meter)
	J-876-4628	10	Pad, Radiator
	15C82	2	5/16" x 1-1/4" Hex Head Cap Screw
	14Z77	2	5/16" Lock Nut
	27L54	7	5/16" Cut Washer
	P-876-4628	1	Support, Radiator (Top)
	NA-876-5222W	1	Pipe, Water (Lower Radiator)
	FC-876-5224	1	Hose, 1.38" I.D. x 5"
	16L58	1	Hose, Radiator (Upper)
	27X30	1	Hose, Radiator (Lower)
	23H32	6	Clamp, Hose
	R-80-481W	1	Hose Assembly, 1/2" x 36" (Oil Drain)
	23L89	1	Elbow, 90° - 1/2" O.D. Tube x 1/2" N.P.T.F.
	12T61	1	Plug, Flared Tube, 37° Type Std. - 1/2" Tube O.D.
a	14J99	1	Sending Unit, Temperature
	23D31	1	Bushing, 1/2" x 3/8" N.P.T.
	14J97	1	Sending Unit, Oil Pressure
	14T41	1	Tee, 1/8" M. x 1/8" Fe. x 1/8" Fe. N.P.T.F. Brass
	23X30	1	3/8" x 3" Hex Head Cap Screw
	26C50	4	5/8" x 2" Hex Head Cap Screw
	JB-876-5222W	1	Mount, Engine (Right Front)
	JA-876-5222W	1	Mount, Engine (Left Front)
	A-876-5423	2	Support, Pump Box (Rear)
	26C47	12	5/8" x 1-1/4" Hex Head Cap Screw

REF.	PART NUMBER	QTY.	DESCRIPTION
	27L59	8	5/8" Cut Washer
	12Z46	4	5/8" Lock Nut
	27L84	12	5/8" Lock Washer
	29P34	1	Gearbox, Pump Drive (With Clutch) (See Section 12 For Breakdown)
	27X83	1	Bearing, Pilot
	27X79	12	3/8" x 1-1/4" Ferry Head Cap Screw
	13M81	8	3/8" x 1-3/4" Hex Head Cap Screw
	27L78	20	3/8" Lock Washer
	28N85	1	Shim, 1/8" (For Pilot Bearing)
	NV-17.9	6	Washer, Snubbing - 9/16" I.D. x 2" O.D. x 10 Ga. Sfl.
	16F90	4	Mount, Vibration (Rear)
	27V90	2	Mount, Vibration (Front)
	26A03	6	1/2" x 3-1/2" Hex Head Cap Screw
	27L58	6	1/2" Cut Washer
	12Z45	6	1/2" Lock Nut
	10E10	13	3/8" x 1-1/4" Hex Head Cap Screw
	12H23	12	3/8" Lock Nut
	27L56	15	3/8" Cut Washer
	A-876-5222W	1	Sill, Engine
	15Y18	1	Muffler
	20V15	2	Clamp Half, Muffler
	20V14	1	Gasket, Flange Exhaust
	DB-876-5224	1	Elbow, Air Cleaner
	16X63	1	Hose, 3" I.D. x 18.50"
	DC-876-5224	1	Sleeve, Connecting - 2.5" O.D.
	EB-876-5223	1	Baffle, Top Cooler
	13J31	6	1/4" x 3/4" Hex Head Cap Screw
	27C86	6	1/4" Nut
	27L76	6	1/4" Lock Washer
	27L52	8	1/4" Cut Washer
	13M81	1	3/8" x 1.75" Hex Head Cap Screw
	27C90	2	3/8" Nut
	27L78	4	3/8" Lock Washer
	26C53	1	3/8" x 1" Hex Head Cap Screw
	31K70	1	Cap, Rain
	28J07	1	Pipe, Exhaust
	15Y81	1	Clamp
	23V67	1	5/16" x 1" Hex Head Cap Screw
	20X06	4	5/16" x 1-1/2" Hex Head Cap Screw
	27C87	4	5/16" Nut
	27L77	7	5/16" Lock Washer
	12X06	1	Switch, Engine Kill (Mounted on Operators Station Panel)
	27V87	1	Alternator
	12S67	1	Sheave
	A-876-5228	1	Bracket, Throttle Cable
	28F21	1	Tower (For Alternator)
	28F31	1	Terminal, Female (For Alternator)
	28F32	1	Seal, Cable (For Alternator)

REF.	PART NUMBER	QTY.	DESCRIPTION
	MA-876-5287W	1	Cable, Battery (Positive)
	27C90	1	3/8" Hex Nut
	GF-876-5287W	1	Wire, Jumper
	27L78	1	3/8" Lock Washer
	26C97	1	3/8" External Tooth Lock Washer
	XA-876-5287W	1	Harness, Starter
	XC-876-5287W	1	Harness, Engine
b	14L31	1	Hose, 1/4" I.D. x 15'-0"
	23D49	2	Connector, 1/4" I.D. Tube x 1/4" O.D. Tube
	23C18	1	Elbow, 90° - 1/4" O.D. Tube x 1/4" N.P.T.
	20N41	4	Clamp, Hose
	23D29	2	Bushing, 3/8" x 1/4" N.P.T.
	23F08	1	Elbow, 90° - 1/4" O.D. Tube x 1/8" N.P.T.
	DD-876-5223	1	Tube (Fuel Return)
	10B23	3	Strap, Cable
	23M29	1	Connector, 1/4" Male N.P.T.F. x 1/4" I.D.
	28K38	1	Wire, Sealing
	16F93	1	Cleaner, Air (Complete With Element) (Consisting in part of the following indented item):
	16F94	1	• Element, Air Cleaner
	16L08	1	Band, Mounting
	26E25	2	5/16" x .75" Hex Head Cap Screw
	28N89	1	Elbow, 2.50" I.D. Rubber
	A-46-2267	1	Elbow, 3" O.D. Tube
	14S36	1	Clamp, 3" Exhaust
	28N88	1	Elbow, 3" x 3.50" Rubber
	23H35	1	Clamp
	23H34	5	Clamp
	16L10	1	Cap, Rain (For Air Cleaner)
	28T19	1	Cap, Pipe
	GC-876-5222W	2	Hanger, Air Cleaner
	23Y18	2	5/16" x 2" Hex Head Cap Screw
	27L54	2	5/16" Cut Washer
	27L77	2	5/16" Lock Washer
	27C87	2	5/16" Hex Nut

- a - Serviceable as a complete unit only.
b - Be sure to specify length when ordering.

**POWER UNIT
(John Deere 4239T)**

E-876-5420B

(Before Ordering, Consult Table of Contents to Verify Proper Bill of Material Number.)

REF.	PART NUMBER	QTY.	DESCRIPTION
	28W83	1	Engine, John Deere 4239T (See Separate Manual)
	28T32	1	Radiator
	DB-876-5224	1	Elbow, Air Cleaner
	A-46-2030	1	Reducer, Molded Rubber
	S-876-4628	1	Plate, Water Pump
	J-876-4628	10	Pads, Radiator Support
	DA-876-5224	1	Stack, Intake
	15G35	1	Valve, Radiator Drain
	CA-876-5224	1	Support, Bottom
	CC-876-5224	1	Pad, Radiator
	15C82	2	5/16" x 1-1/4" Hex Head Cap Screw
	14Z77	2	5/16" Hex Nut
	27L54	3	5/16" Lock Washer
	27C87	1	5/16" Hex Nut
	27L77	1	5/16" Lock Washer
	P-876-4628	1	Support, Radiator (Top)
	H-876-4628	1	Bracket, Water Pump
	26C53	7	3/8" x 1" Hex Head Cap Screw
	27C90	5	3/8" Hex Nut
	27L78	10	3/8" Lock Washer
	23Y18	1	5/16" x 2" Hex Head Cap Screw
	BQ-876-5283	4	Strap, Rubber
	28L03	1	Fan
	28W05	1	Spacer, Fan
	23X30	4	3/8" x 3" Hex Head Cap Screw
	27L78	4	3/8" Lock Washer
	11N32	2	3/8" x 2" Hex Head Cap Screw
	14T41	1	Tee, 1/8" M. x 1/8" Fe. x 1/8" Fe. N.P.T.F. Brass
	23V18	1	Hose, Radiator (Top)
	28K99	1	Hose, Radiator (Bottom)
	26E28	2	1/2" x 1.25" Hex Head Cap Screw
	27L58	4	1/2" Cut Washer
	27C95	2	1/2" Hex Nut
	23H33	2	Clamp, Hose
	27L56	7	3/8" Cut Washer
	23H32	2	Clamp, Hose
	13J31	4	1/4" x .75" Hex Head Cap Screw
	27C86	4	1/4" Hex Nut
	27L76	4	1/4" Lock Washer
	27L57	4	1/4" Cut Washer
	AJ-80-481W	1	Hose Assembly, 1/2" x 28" (Oil Drain)
	23R13	1	Elbow, 90° - Body Only - 1/2" O.D. Tube x 7/8"-14 Str. Thd.
	12T61	1	Plug, Flared Tube, 37° Type Stl. - 1/2" Tube O.D.

REF.	PART NUMBER	QTY.	DESCRIPTION
	JB-876-5222W	1	Mount, Engine (Right Front)
	JA-876-5222W	1	Mount, Engine (Left Front)
	A-876-5423	2	Support, Pump Box (Rear)
	26C47	12	5/8" x 1-1/4" Hex Head Cap Screw
	27L59	8	5/8" Cut Washer
	17Z46	4	5/8" Lock Nut
	26C50	4	5/8" x 2" Hex Head Cap Screw
	27L84	12	5/8" Lock Washer
	28F34	1	Gearbox, Pump Drive (With Clutch) (See Section 12 For Breakdown)
	27X83	1	Bearing, Pilot
	27X79	12	3/8" x 1-1/4" Flange Head Cap Screw
	13M81	8	3/8" x 1-3/4" Hex Head Cap Screw
	27L78	20	3/8" Lock Washer
	NY-17-9	6	Washer, Snubbing - 9/16" I.D. x 2" O.D. x 10 Ga. Stl.
	16F90	4	Mount, Vibration (Rear)
	27V90	2	Mount, Vibration (Front)
	26A03	6	1/2" x 3-1/2" Hex Head Cap Screw
	27L58	6	1/2" Cut Washer
	12Z45	6	1/2" Lock Nut
	10E10	12	3/8" x 1-1/4" Hex Head Cap Screw
	12H23	12	3/8" Lock Nut
	A-876-5222W	1	Sill, Engine
	27L56	12	3/8" Cut Washer
	A-876-4768	1	Bracket, Throttle Cable
a	14J99	1	Sending Unit, Temperature
	23D31	1	Bushing, 1/2" x 3/8" N.P.T.
	14J97	1	Sending Unit, Oil Pressure
	16L02	1	Alternator (55 Amp)
	20G13	1	Switch, Pressure (For Hour Meter)
	23H35	2	Clamp, Worm Drive
	16F93	1	Cleaner, Air (Complete With Element) (Consisting in part of the following indented item):
	16F94	1	. Element, Air Cleaner
	16L08	1	Band, Mounting
	26E25	2	5/16" x .75" Hex Head Cap Screw
	27C87	2	5/16" Nut
	27L77	2	5/16" Lock Washer
	28N91	1	Elbow, Molded - 45° x 3" I.D.
	28N88	1	Elbow, Molded - 90° x 3-1/2" I.D. x 3" O.D.
	23H34	3	Clamp, Worm Drive
	16L10	1	Cap, Air Cleaner
	7D-876-5223	1	Tubing, 3" O.D. x 1.5"
	28N85	1	Shim, 1/8" (For Pilot Bearing)
	28T18	1	Cap, Pipe
	10B23	3	Strap, Cable
	12X06	1	Switch, Engine Kill (Mounted on Operators Station Panel)
b	14L31	1	Hose, 1/4" I.D. x 15'-0"
	23M29	1	Connector, 1/4" Male N.P.T.F. x 1/4" I.D.

REF.	PART NUMBER	QTY.	DESCRIPTION
	23D49	2	Connector, 1/4" I.D. Hose x 1/4" O.D. Tube
	23C18	1	Elbow, 90° - 1/4" O.D. T. x 1/4" N.P.T.
	20N41	4	Clamp, Hose
	23D29	2	Bushing, 3/8" x 1/4" N.P.T.
	23F08	1	Elbow, 90° - 1/4" O.D. Tube x 1/8" N.P.T.T.
	DD-876-5223	1	Tube (Fuel Return)
	16F92	1	Muffler, Wrapped
	AG-876-4628	1	Stack, Exhaust
	31K69	1	Cap, Rain
	14S36	2	Clamp, 3"
	16G65	1	Reducer
	13N60	1	Clamp, 4"
	BA-876-5223	1	Support, Muffler (Lower)
	H-3-675	1	Collar
	BC-876-5222W	1	Support, Muffler (Upper)
	AC-876-4628	1	Strap
	13M69	1	1/4" x 1.50" Hex Head Cap Screw
	10C10	2	3/8" x 1.25" Hex Head Cap Screw
	27L56	1	3/8" Cut Washer
	28F21	1	Tower (For Alternator)
	28F31	1	Terminal, Female (For Alternator)
	28F32	1	Seal, Cable (For Alternator)
	27L76	1	1/4" Lock Washer
	MA-876-5287W	1	Cable, Battery (Positive)
	27C86	1	1/4" Hex Nut
	GF-876-5287W	1	Wire, Jumper
	27C90	2	3/8" Hex Nut
	27L78	2	3/8" Lock Washer
	26C97	1	3/8" External Tooth Lock Washer
	XA-876-5287W	1	Harness, Starter
	XC-876-5287W	1	Harness, Engine
	GC-876-5222W	2	Hanger, Air Cleaner
	23Y18	2	5/16" x 2" Hex Head Cap Screw
	27L54	2	5/16" Cut Wash
	27L77	2	5/16" Lock Washer
	27C87	2	5/16" Hex Nut
	26C53	1	3/8" x 1" Hex Head Cap Screw
	26E28	1	1/2" x 1.25" Hex Head Cap Screw
	27L58	1	1/2" Cut Washer
	27L81	1	1/2" Lock Washer
	23X30	1	3/8" x 3" Hex Head Cap Screw
	27C90	2	3/8" Hex Nut
	27L78	2	3/8" Lock Washer
	23V67	1	5/16" x 1" Hex Head Cap Screw
	27L54	1	5/16" Cut Washer
	27L77	1	5/16" Lock Washer

a - Serviceable as a complete unit only.

b - Be sure to specify length when ordering.

**POWER UNIT
(John Deere 4239TL)**

B3-876-5420B

(Before Ordering, Consult Table of Contents to Verify Proper Bill of Material Number.)

REF.	PART NUMBER	QTY.	DESCRIPTION
	28T19	1	Engine, John Deere 4239TL (See Separate Manual) (Consisting in part of the following commonly ordered engine components):
	WFN-T19(044	1	. Filter, Oil
	WFN-AR5(X)41	1	. Filter, Fuel
	28T52	1	Radiator
	26E28	2	1/2" x 1.25" Hex Head Cap Screw
	27L58	4	1/2" Cut Washer
	27C95	2	1/2" Hex Nut
	J-876-462B	10	Pad, Radiator
	15G35	1	Valve, Drain
	CA-876-5224	1	Support, Bottom
	CC-876-5224	1	Pad, Radiator
	15C82	2	5/16" x 1.25" Hex Head Cap Screw
	14Z77	2	5/16" Hex Nut
	27L54	5	5/16" Lock Washer
	27CB7	3	5/16" Hex Nut
	27L77	3	5/16" Lock Washer
	P-876-4628	1	Support, Radiator (Top)
	H-876-4628	1	Bracket, Water Pump
	26C53	7	3/8" x 1.00" Hex Head Cap Screw
	27C90	5	3/8" Hex Nut
	27L78	10	3/8" Lock Washer
	23Y18	3	5/16" x 2.00" Hex Head Cap Screw
	BD-876-5283	4	Strap, Rubber
a	28L03	1	Fan
	28W05	1	Spacer, Fan
	23X30	4	3/8" x 3" Hex Head Cap Screw
	27L78	4	3/8" Lock Washer
	11N32	2	3/8" x 2" Hex Head Cap Screw
	14T41	1	Tee, 1/8" Ma. x 1/8" Fe. x 1/8" Fe. N.P.T.F. Brass
	23V18	1	Hose, Radiator (Top)
	28K99	1	Hose, Radiator (Bottom)
	23H32	2	Clamp, Hose
	23H33	2	Clamp, Hose
	27L56	7	3/8" Cut Washer
	13J31	4	1/4" x .75" Hex Head Cap Screw
	27CB6	4	1/4" Hex Nut
	27L76	4	1/4" Lock Washer
	27L52	4	1/4" Cut Washer
	CC-876-5222W	2	Hanger, Air Cleaner
	AJ-80-481W	1	Hose Assembly, 1/2" x 28" (Oil Drain)
	23R13	1	Elbow, 90° - 1/2" O.D. Tube x 7/8"-14 Str. Thd. (Body Only)

REF.	PART NUMBER	QTY.	DESCRIPTION
	12T61	1	Plug, Flared Tube, 37° Type Stl., 1/2" Tube O.D.
	JB-876-5227W	1	Mount, Engine (Right Front)
	JA-876-5222W	1	Mount, Engine (Left Front)
	A-876-5423	2	Support, Pump Box (Rear)
	26C47	12	5/8" x 1.25" Hex Head Cap Screw
	27L59	8	5/8" Cut Washer
	12Z46	4	5/8" Lock Nut
	26C50	4	5/8" x 2" Hex Head Cap Screw
	27L94	12	5/8" Lock Washer
	28P34	1	Gear Box, Pump Drive (With Clutch) (See Section 12 For Breakdown)
	27X83	1	Bearing, Pilot
	27X79	12	3/8" x 1.25" Ferry Head Cap Screw
	13M81	8	3/8" x 1.75" Hex Head Cap Screw (Grade 8)
	27L78	20	3/8" Lock Washer
	NV-17-9	6	Washer, Snubbing - 9/16" I.D. x 2" O.D. x 10 Ga. Stl.
	16F90	4	Mount, Vibration (Rear)
	27V90	2	Mount, Vibration (Front)
	26A03	6	1/2" x 3.50" Hex Head Cap Screw
	27L58	6	1/2" Cut Washer
	12Z45	6	1/2" Lock Nut
	10E10	12	3/8" x 1.25" Hex Head Cap Screw
	12H23	12	3/8" Lock Nut
	A-876-5222W	1	Sill, Engine
	27L56	12	3/8" Cut Washer
a	A-876-4768	1	Bracket, Throttle Cable
	14J99	1	Sending Unit, Temperature
	23D31	1	Bushing, 1/2" x 3/8" N.P.T.
	14J97	1	Sending Unit, Oil Pressure
	16L02	1	Alternator, 55 Amp.
	20G13	1	Switch, Pressure (For Hour Meter)
	23H35	1	Clamp, Worm Drive
	16F93	1	Cleaner, Air (Complete With Element) (Consisting in part of the following indented items):
	16F94	1	Element, Air Cleaner
	16L08	1	Band, Mounting
	26E25	2	5/16" x .75" Hex Head Cap Screw
	27C87	2	5/16" Nut
	27L77	2	5/16" Lock Washer
	28N91	1	Elbow, Molded - 45° x 3" I.D.
	28N88	1	Elbow, Molded - 90° x 3.50" I.D. x 3" O.D. x 3.50"
	23H34	3	Clamp, Worm Drive
	16L10	1	Cap, Air Cleaner
	28N85	1	Shim, 1/8" (For Pilot Bearing)
	28T18	1	Cap, Pipe
	10B23	3	Strap, Cable
	12X06	1	Switch, Engine Kill (Located on Operators Panel)
b	14L31	1	Hose, 1/4" I.D. x 15'-0"
	23M29	1	Connector, 1/4" Male N.P.T.F. x 1/4" I.D.
	23D49	2	Connector, 1/4" I.D. Hose x 1/4" O.D. Tube

REF.	PART NUMBER	QTY.	DESCRIPTION
	23C18	1	Elbow, 90°, 1/4" O.D. Tube x 1/4" N.P.T.
	20N41	4	Clamp, Hose
	23D29	2	Bushing, 3/8" x 1/4" N.P.T.
	23F08	1	Elbow, 90° - 1/4" T. x 1/8" N.P.T.F.
	DD-876-5223	1	Tube x 1/4"
	16F92	1	Muffler, Wrapped
	AG-876-4628	1	Stack, Exhaust
	31K69	1	Cap, Rain
	14S36	2	Clamp, 3"
	16G65	1	Reducer
	13N60	1	Clamp, 4"
	BA-876-5223	1	Support, Muffler (Lower)
	H-3-675	1	Collar
	RC-876-5222W	1	Support, Muffler (Upper)
	AC-876-4628	1	Strap
	13M69	1	1/5" x 1.50" Hex Head Cap Screw
	10E10	2	3/8" x 1.25" Hex Head Cap Screw
	27L56	1	3/8" Cut Washer
	28F21	1	Tower (For Alternator)
	28F31	1	Terminal, Female (For Alternator)
	28F32	1	Seal, Cable (For Alternator)
	27L76	1	1/4" Lock Washer
	MA-876-5287W	1	Cable, Battery (Positive)
	27C86	1	1/4" Hex Nut
	GF-876-5287W	1	Wire, Jumper
	27C90	2	3/8" Hex Nut
	27L78	2	3/8" Lock Washer
	26C97	1	3/8" External Tooth Lock Washer
	XA-876-5287W	1	Harness, Starter
	XC-876-5287W	1	Harness, Engine
	DA-876-5224	1	Stack, Intake
	DB-876-5224	1	Elbow, Air Cleaner
	16X59	1	Connector, End - 3" I.D. x 3" O.D. x 6"
	26C53	1	3/8" x 1" Hex Head Cap Screw
	26E28	1	1/2" x 1.25" Hex Head Cap Screw
	27L58	1	1/2" Cut Washer
	27L81	1	1/2" Lock Washer
	23X30	1	3/8" x 3" Hex Head Cap Screw
	27C90	2	3/8" Hex Nut
	27L78	2	3/8" Lock Washer
	23V67	1	5/16" x 1" Hex Head Cap Screw
	27L54	1	5/16" Cut Washer
	27L77	1	5/16" Lock Washer

- a - Serviceable as a complete unit only.
- b - Be sure to specify length when ordering.

**POWER UNIT
(John Deere 4239TL)**

B4-876-5420B

(Before Ordering, Consult Table of Contents to Verify Proper Bill of Material Number.)

REF.	PART NUMBER	QTY.	DESCRIPTION
	28T19	1	Engine, John Deere 4239TL (See Separate Manual) (Consisting in part of the following commonly ordered engine components):
	WEN-T19044	1	. Filter, Oil
	WEN-AR50041	1	. Filter, Fuel
	28T52	1	Radiator
	26E28	2	1/2" x 1.25" Hex Head Cap Screw
	27L58	4	1/2" Cut Washer
	27C95	2	1/2" Hex Nut
	J-876-462B	10	Pad, Radiator
	15C35	1	Valve, Drain
	CA-876-5224	1	Support, Bottom
	CC-876-5224	1	Pad, Radiator
	15C82	2	5/16" x 1.25" Hex Head Cap Screw
	14Z77	2	5/16" Hex Nut
	27L54	5	5/16" Lock Washer
	27C87	3	5/16" Hex Nut
	27L77	3	5/16" Lock Washer
	P-876-462B	1	Support, Radiator (Top)
	H-876-462B	1	Bracket, Water Pump
	26C53	7	3/8" x 1.00" Hex Head Cap Screw
	27C90	5	3/8" Hex Nut
	27L78	10	3/8" Lock Washer
	23Y18	3	5/16" x 2.00" Hex Head Cap Screw
	BD-876-5283	4	Strap, Rubber
o	28L03	1	Fan
	28W05	1	Spacer, Fan
	23X30	4	3/8" x 3" Hex Head Cap Screw
	27L78	4	3/8" Lock Washer
	11N32	2	3/8" x 2" Hex Head Cap Screw
	14T41	1	Tee, 1/8" Ma. x 1/8" Fe. x 1/8" Fe. N.P.T.F. Brass
	23V18	1	Hose, Radiator (Top)
	29K99	1	Hose, Radiator (Bottom)
	EA-876-5222W	2	Mount, Oil Cooler
	ED-876-5224	1	Baffle, Oil Cooler
	23H32	2	Clamp, Hose
	23H33	2	Clamp, Hose
	27L56	7	3/8" Cut Washer
	13J31	6	1/4" x .75" Hex Head Cap Screw
	27C86	6	1/4" Hex Nut
	27L76	6	1/4" Lock Washer
	27L52	8	1/4" Cut Washer
	GC-876-5222W	2	Hanger, Air Cleaner
	AJ-80-491W	1	Hose Assembly, 1/2" x 28" (Oil Drain)

REF.	PART NUMBER	QTY.	DESCRIPTION
	23R13	1	Elbow, 90° - 1/2" O.D. Tube x 7/8"-14 Str. Thd. (Body Only)
	12T61	1	Plug, Flared Tube, 37° Type 511., 1/2" Tube O.D.
	JB-876-5222W	1	Mount, Engine (Right Front)
	JA-876-5222W	1	Mount, Engine (Left Front)
	A-876-5423	2	Support, Pump Box (Rear)
	26C47	12	5/8" x 1.25" Hex Head Cap Screw
	27L59	8	5/8" Cut Washer
	12Z46	4	5/8" Lock Nut
	26C50	4	5/8" x 2" Hex Head Cap Screw
	27L84	12	5/8" Lock Washer
	28P34	1	Gear Box, Pump Drive (With Clutch) (See Section 12 For Breakdown)
	27X83	1	Bearing, Pilot
	27X79	12	3/8" x 1.25" Ferry Head Cap Screw
	13MB1	8	3/8" x 1.75" Hex Head Cap Screw (Grade 8)
	27L78	20	3/8" Lock Washer
	NV-17-9	6	Washer, Snubbing - 9/16" I.D. x 2" O.D. x 10 Ga. Stl.
	16F90	4	Mount, Vibration (Rear)
	27V90	2	Mount, Vibration (Front)
	26A03	6	1/2" x 3.50" Hex Head Cap Screw
	27L58	6	1/2" Cut Washer
	12Z45	6	1/2" Lock Nut
	10E10	12	3/8" x 1.25" Hex Head Cap Screw
	12H23	12	3/8" Lock Nut
	A-876-5222W	1	Sill, Engine
	27L56	12	3/8" Cut Washer
	A-876-476B	1	Bracket, Throttle Cable
a	14J99	1	Sending Unit, Temperature
	23D31	1	Bushing, 1/2" x 3/8" N.P.T.
	14J97	1	Sending Unit, Oil Pressure
	16L02	1	Alternator, 55 Amp.
	20G13	1	Switch, Pressure (For Hour Meter)
	23H35	1	Clamp, Worm Drive
	16F93	1	Cleaner, Air (Complete With Element) (Consisting in part of the following indented item):
	16F94	1	. Element, Air Cleaner
	16L08	1	Band, Mounting
	26E25	2	5/16" x .75" Hex Head Cap Screw
	27C87	2	5/16" Nut
	27L77	2	5/16" Lock Washer
	28N91	1	Elbow, Molded - 45° x 3" I.D.
	28N88	1	Elbow, Molded - 90° x 3.50" I.D. x 3" O.D. x 3.50"
	23H34	3	Clamp, Worm Drive
	16L10	1	Cap, Air Cleaner
	28N85	1	Shim, 1/8" (For Pilot Bearing)
	28T18	1	Cap, Pipe
	10B23	3	Strop, Cable
	12X06	1	Switch, Engine Kill (Located on Operators Panel)
b	14L31	1	Hose, 1/4" I.D. x 15'-0"

REF.	PART NUMBER	QTY.	DESCRIPTION
	23M29	1	Connector, 1/4" Male N.P.T.F. x 1/4" I.D.
	23D49	2	Connector, 1/4" I.D. Hose x 1/4" O.D. Tube
	23C18	1	Elbow, 90°, 1/4" O.D. Tube x 1/4" N.P.T.
	20N41	4	Clamp, Hose
	23D29	2	Bushing, 3/8" x 1/4" N.P.T.
	23F08	1	Elbow, 90° - 1/4" T. x 1/8" N.P.T.F.
	00-876-5223	1	Tube x 1/4"
	16F92	1	Muffler, Wrapped
	AG-876-4628	1	Stack, Exhaust
	31K69	1	Cap, Rain
	14536	2	Clamp, 3"
	16G65	1	Reducer
	13N60	1	Clamp, 4"
	BA-876-5223	1	Support, Muffler (Lower)
	H-3-675	1	Collar
	BC-876-5222W	1	Support, Muffler (Upper)
	AC-876-4628	1	Strap
	13M69	1	1/4" x 1.50" Hex Head Cap Screw
	10E10	2	3/8" x 1.25" Hex Head Cap Screw
	27L56	1	3/8" Cut Washer
	28F21	1	Tower (For Alternator)
	28F31	1	Terminal, Female (For Alternator)
	28F32	1	Seal, Cable (For Alternator)
	27L76	1	1/4" Lock Washer
	MA-876-5287W	1	Cable, Battery (Positive)
	27C86	1	1/4" Hex Nut
	GF-876-5287W	1	Wire, Jumper
	27C90	2	3/8" Hex Nut
	27L78	2	3/8" Lock Washer
	26C97	1	3/8" External Tooth Lock Washer
	XA-876-5287W	1	Harness, Starter
	XC-876-5287W	1	Harness, Engine
	DA-876-5224	1	Stack, Intake
	DB-876-5224	1	Elbow, Air Cleaner
	16X59	1	Connector, End - 3" I.D. x 3" O.D. x 6"
	26C53	1	3/8" x 1" Hex Head Cap Screw
	26E2B	1	1/2" x 1.25" Hex Head Cap Screw
	27L58	1	1/2" Cut Washer
	27L81	1	1/2" Lock Washer
	23X30	1	3/8" x 3" Hex Head Cap Screw
	27C90	2	3/8" Hex Nut
	27L78	2	3/8" Lock Washer
	23V67	1	5/16" x 1" Hex Head Cap Screw
	27L54	1	5/16" Cut Washer
	27L77	1	5/16" Lock Washer

- a - Serviceable as a complete unit only.
- b - Be sure to specify length when ordering.

**POWER UNIT
(John Deere 4039TL)**

B5-876-5420B

(Before Ordering, Consult Table of Contents to Verify Proper Bill of Material Number.)

REF.	PART NUMBER	QTY.	DESCRIPTION
	29L06	1	Engine, John Deere 4039TL (See Separate Manual) (Consisting in part of the following commonly ordered engine components):
	WEN-T19044	1	. Filter, Oil
	WEN-LAR50041	1	. Filter, Fuel
	28T52	1	Radiator
	26E28	2	1/2" x 1.25" Hex Head Cap Screw
	27L58	4	1/2" Cut Washer
	27C95	2	1/2" Hex Nut
	J-876-4628	10	Pad, Radiator
	23I178	1	Filter, Breather
	15G35	1	Valve, Drain
	CA-876-5224	1	Support, Bottom
	CC-876-5224	1	Pad, Radiator
	15C82	2	5/16" x 1.25" Hex Head Cap Screw
	14Z77	2	5/16" Hex Nut
	27L54	5	5/16" Lock Washer
	27C87	3	5/16" Hex Nut
	27L77	3	5/16" Lock Washer
	P-876-4628	1	Support, Radiator (Top)
	H-876-4628	1	Bracket, Water Pump
	26C53	7	3/8" x 1.00" Hex Head Cap Screw
	27C90	5	3/8" Hex Nut
	27L78	10	3/8" Lock Washer
	23Y18	3	5/16" x 2.00" Hex Head Cap Screw
	BD-876-5283	4	Strap, Rubber
a	28L03	1	Fan
	28W05	1	Spacer, Fan
	23X30	4	3/8" x 3" Hex Head Cap Screw
	27L78	4	3/8" Lock Washer
	11N32	2	3/8" x 2" Hex Head Cap Screw
	14T41	1	Tee, 1/8" Ma. x 1/8" Fe. x 1/9" Fe. N.P.T.F. Brass
	23B39	1	Coupling, Reducer - 1/2" N.P.T. x 3/8" N.P.T.
	23V18	1	Hose, Radiator (Top)
	28K99	1	Hose, Radiator (Bottom)
	EA-876-5222W	2	Mount, Oil Cooler
	ED-876-5224	1	Baffle, Oil Cooler
	23H32	2	Clamp, Hose
	23H33	2	Clamp, Hose
	27L56	7	3/8" Cut Washer
	E-17-122	1	Nipple, 1/2" N.P.T. x 4"
	13J31	6	1/4" x .75" Hex Head Cap Screw
	27C86	6	1/4" Hex Nut
	27L76	6	1/4" Lock Washer

REF.	PART NUMBER	QTY.	DESCRIPTION
	27L52	8	1/4" Cut Washer
	MB-876-5222W	1	Hanger, Air Cleaner
	AJ-80-481W	1	Hose Assembly, 1/2" x 28" (Oil Drain)
	23R13	1	Elbow, 90° - 1/2" O.D. Tube x 7/8"-14 Str. Thd. (Body Only)
	12T61	1	Plug, Flared Tube, 37° Type Stl., 1/2" Tube O.D.
	JB-876-5222W	1	Mount, Engine (Right Front)
	JA-876-5222W	1	Mount, Engine (Left Front)
	A-876-5423	2	Support, Pump Box (Rear)
	26C47	12	5/8" x 1.25" Hex Head Cap Screw
	27L59	8	5/8" Cut Washer
	12Z46	4	5/8" Lock Nut
	26C50	4	5/8" x 2" Hex Head Cap Screw
	27L84	12	5/8" Lock Washer
	28P34	1	Gear Box, Pump Drive (With Clutch) (See Section 12 For Breakdown)
	27X83	1	Bearing, Pilot
	27X79	12	3/8" x 1.25" Hex Head Cap Screw
	13M81	8	3/8" x 1.75" Hex Head Cap Screw (Grade 8)
	27L78	20	3/8" Lock Washer
	NV-17-9	6	Washer, Snubbing - 9/16" I.D. x 2" O.D. x 10 Ga. Stl.
	16F90	4	Mount, Vibration (Rear)
	27V90	2	Mount, Vibration (Front)
	26A03	6	1/2" x 3.50" Hex Head Cap Screw
	27L58	6	1/2" Cut Washer
	12Z45	6	1/2" Lock Nut
	10E10	12	3/8" x 1.25" Hex Head Cap Screw
	12H23	12	3/8" Lock Nut
	A-876-5222W	1	Sill, Engine
	27L56	12	3/8" Cut Washer
	A-876-4768	1	Bracket, Throttle Cable
a	14J99	1	Sending Unit, Temperature
	23D31	1	Bushing, 1/2" x 3/8" N.P.T.
	14J97	1	Sending Unit, Oil Pressure
	20G13	1	Switch, Pressure (For Hour Meter)
	23I135	1	Clamp, Worm Drive
	16F93	1	Cleaner, Air (Complete With Element) (Consisting in part of the following indented items):
	16F94	1	• Element, Air Cleaner
	16L08	2	Band, Mounting
	26E25	4	5/16" x .75" Hex Head Cap Screw
	27C87	4	5/16" Nut
	27L77	4	5/16" Lock Washer
	28N91	1	Elbow, Malted - 45° x 3" I.D.
	28N88	1	Elbow, Malted - 90° x 3.50" I.D. x 3" O.D. x 3.50"
	23H34	3	Clamp, Worm Drive
	16L10	1	Cap, Air Cleaner
	28N85	1	Shim, 1/8" (For Pilot Bearing)
	28T18	1	Cup, Pipe
	10B23	3	Strap, Cable

REF.	PART NUMBER	QTY.	DESCRIPTION
	12X06	1	Switch, Engine Kill (Located on Operators Panel)
b	14L31	1	Hose, 1/4" I.D. x 15'-0"
	23M29	1	Connector, 1/4" Male N.P.T.F. x 1/4" I.D.
	23D49	2	Connector, 1/4" I.D. Hose x 1/4" O.D. Tube
	23C18	1	Elbow, 90°, 1/4" O.D. Tube x 1/4" N.P.T.
	20N41	4	Clamp, Hose
	23D29	2	Bushing, 3/8" x 1/4" N.P.T.
	23F08	1	Elbow, 90° - 1/4" T. x 1/8" N.P.T.F.
	DD-876-5223	1	Tube x 1/4"
	16F92	1	Muffler, Wrapped
	AG-876-4628	1	Stack, Exhaust
	31K69	1	Cap, Rain
	14S36	2	Clamp, 3"
	16G65	1	Reducer
	13N60	1	Clamp, 4"
	DA-876-5223	1	Support, Muffler (Lower)
	H-3-675	1	Collar
	BC-876-5222W	1	Support, Muffler (Upper)
	AC-876-4628	1	Strap
	13M69	1	1/4" x 1.50" Hex Head Cap Screw
	10E10	2	3/8" x 1.25" Hex Head Cap Screw
	27L56	1	3/8" Cut Washer
	27L76	1	1/4" Lock Washer
	MA-876-5287W	1	Cable, Battery (Positive)
	27C86	1	1/4" Hex Nut
	GF-876-5287W	1	Wire, Jumper
	27C90	2	3/8" Hex Nut
	27L78	2	3/8" Lock Washer
	26C97	1	3/8" External Tooth Lock Washer
	DA-876-5224	1	Stack, Intake
	DB-876-5224	1	Elbow, Air Cleaner
	16X59	1	Connector, End - 3" I.D. x 3" O.D. x 6"
	26C53	1	3/8" x 1" Hex Head Cap Screw
	26E28	1	1/2" x 1.25" Hex Head Cap Screw
	27L58	1	1/2" Cut Washer
	27L81	1	1/2" Lock Washer
	27C90	1	3/8" Hex Nut
	27L78	1	3/8" Lock Washer

- a - Serviceable as a complete unit only.
b - Be sure to specify length when ordering.

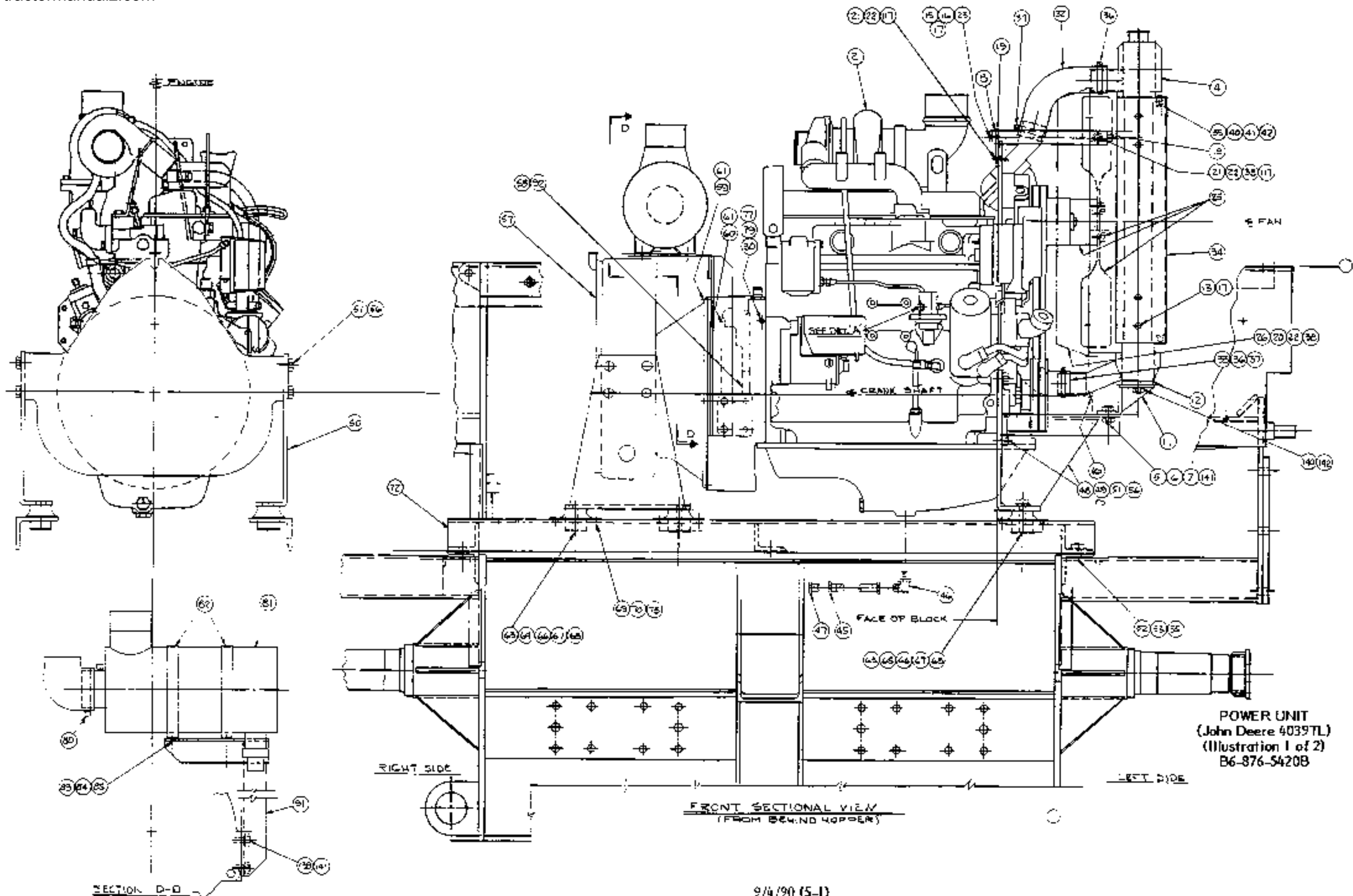

POWER UNIT
 (John Deere 4039TL)
 (Illustration 1 of 2)
 B6-876-54208

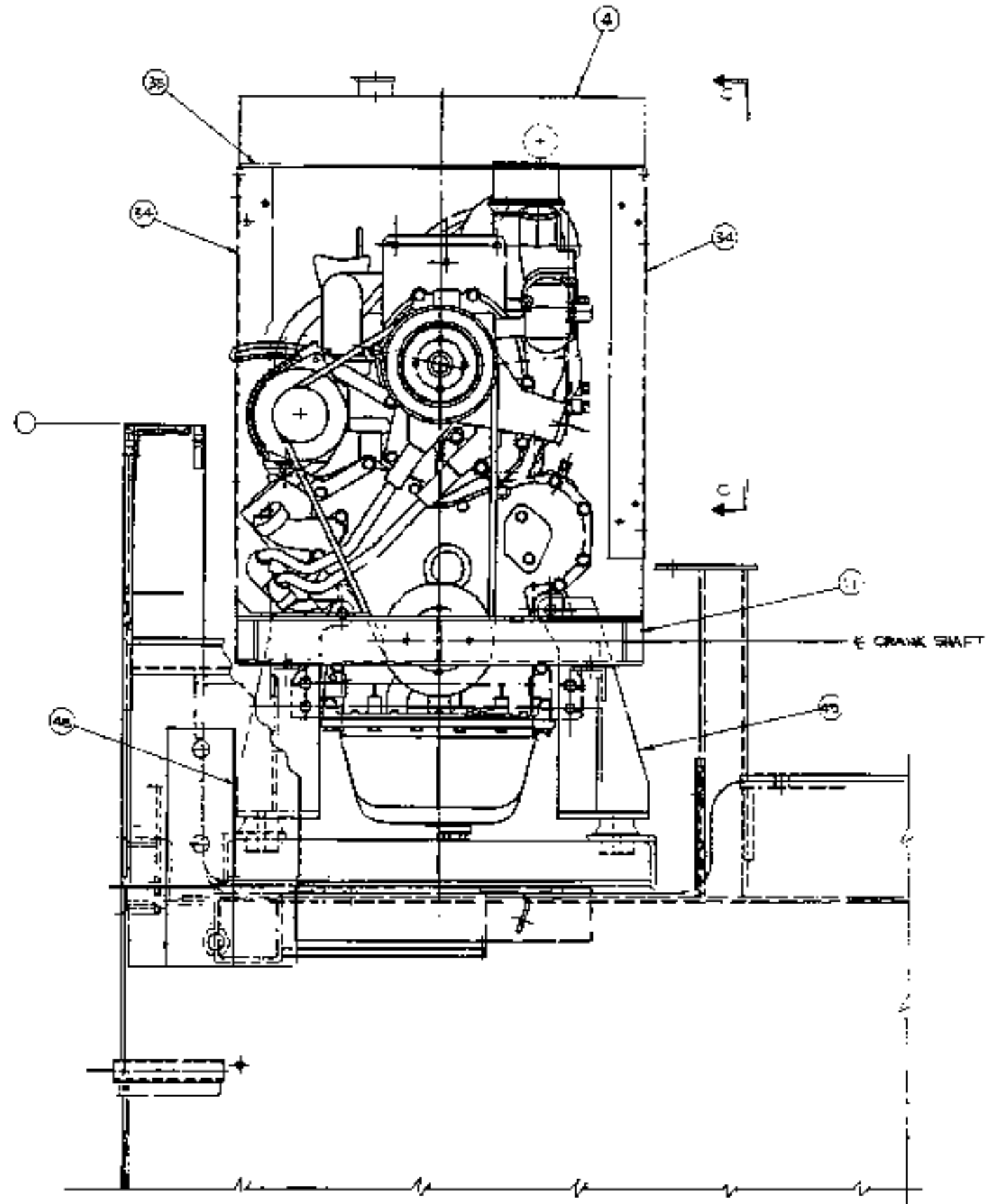

LEFT SIDE VIEW
(FRONT OF ENGINE)

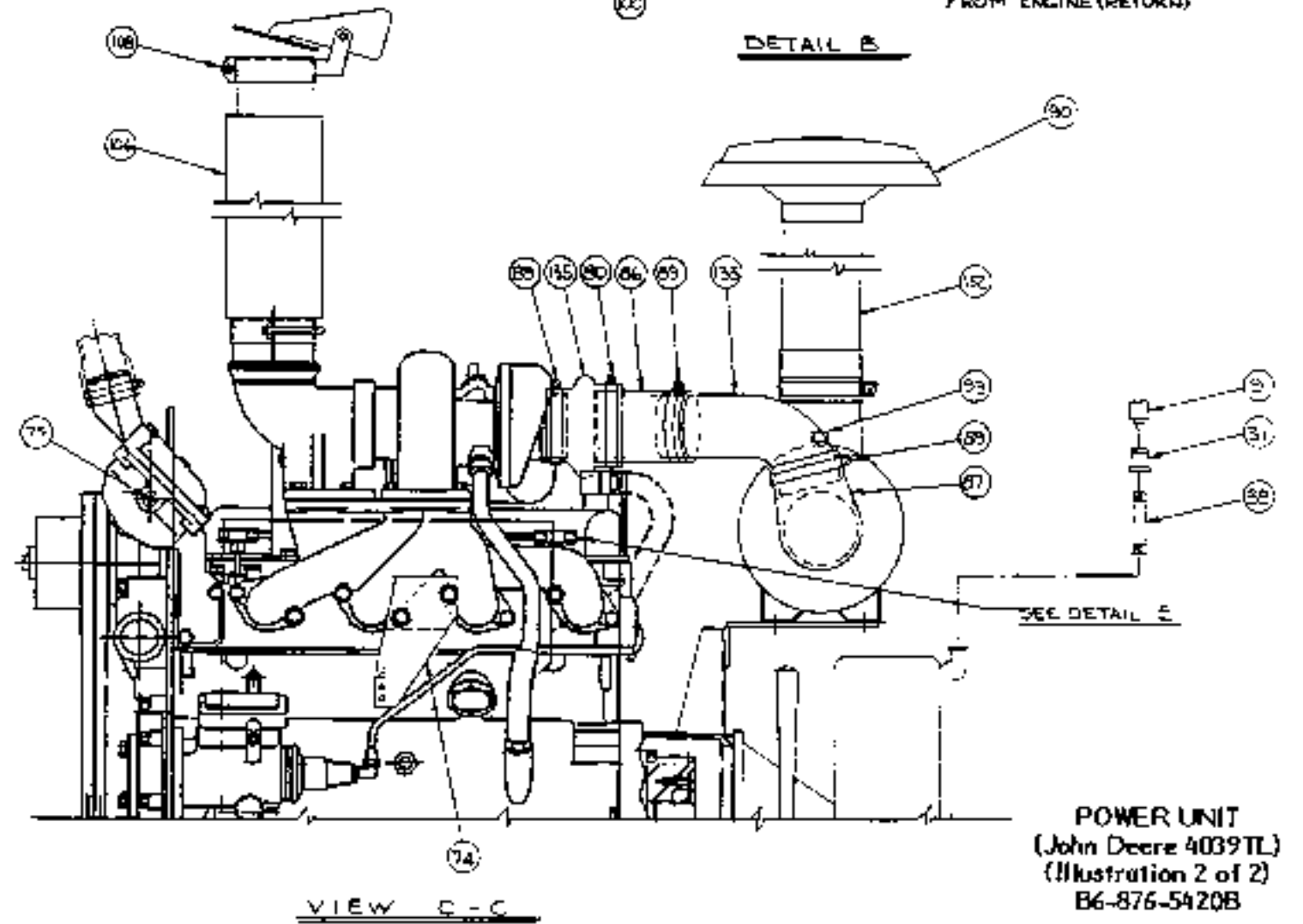
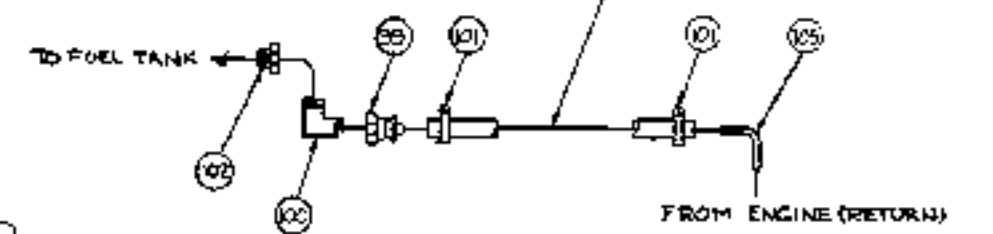
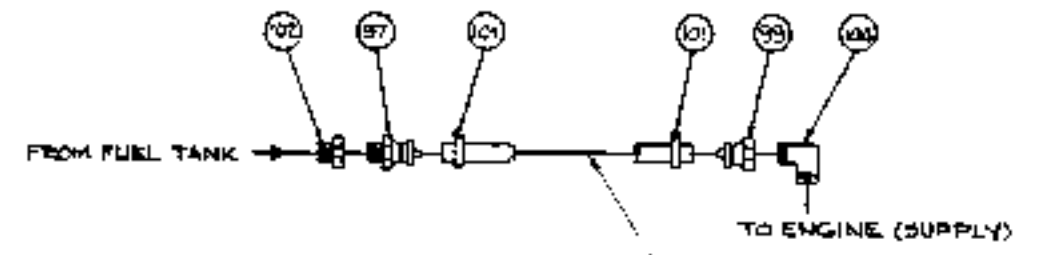

POWER UNIT
(John Deere 4039TL)
(Illustration 2 of 2)
B6-876-5420B

**POWER UNIT
(John Deere 4039TL)**

B6-876-5420B

(Before Ordering, Consult Table of Contents to Verify Proper Bill of Material Number.)

REF.	PART NUMBER	QTY.	DESCRIPTION
Ref. #2 thru #142 Symbolized by  on Illustrations 1 & 2.			
2	29L06	1	Engine, John Deere 4039TL (See Separate Manual) (Consisting in part of the following commonly ordered engine components):
	WEN-T19044	1	. Filter, Oil
	WEN-AR50041	1	. Filter, Fuel
4	29M95	1	Radiator
5	26E29	2	1/2" x 1.50" Hex Head Cap Screw
6	27L58	4	1/2" Cut Washer
7	27C95	2	1/2" Hex Nut
8	J-876-462B	2	Pad, Radiator
9	23H78	1	Filter, Breather
10	15G35	1	Valve, Drain
11	BC-876-5422W	1	Support, Bottom
12	CC-876-5224	1	Pad, Radiator
13	14L97	8	5/16" x .625" Hex Head Cap Screw
15	27L54	1	5/16" Cut Washer
16	27C87	1	5/16" Hex Nut
17	27L77	9	5/16" Lock Washer
18	DB-876-5423	1	Support, Radiator (Top)
19	H-876-462B	1	Bracket, Water Pump
20	26C53	4	3/8" x 1.00" Hex Head Cap Screw
21	27C90	3	3/8" Hex Nut
22	27L78	7	3/8" Lock Washer
23	23Y18	1	5/16" x 2.00" Hex Head Cap Screw
25 a	29M92	1	Fan (With Spacer & Mounting Hardware)
26	29M94	1	Guard, Fan
30	14T41	1	Tee, 1/8" Ma. x 1/8" Fe. x 1/8" Fe. N.P.T.F. Brass
31	23E39	1	Coupling, Reducer - 1/2" N.P.T. x 3/8" N.P.T.
32	23V18	1	Hose, Radiator (Top)
33	28K99	1	Hose, Radiator (Bottom)
34	EA-876-5222W	2	Mount, Oil Cooler
35	ED-876-5224	2	Baffle, Oil Cooler
36	23H32	2	Clamp, Hose
37	23H33	2	Clamp, Hose
38	27L56	6	3/8" Cut Washer
39	F-17-122	1	Nipple, 1/2" N.P.T. x 4"
40	13J31	4	1/4" x .75" Hex Head Cap Screw
41	27C86	4	1/4" Hex Nut
42	27L76	4	1/4" Lock Washer
45	R-80-481W	1	Hose Assembly, 1/2" x 36" (Oil Drain)
46	23R13	1	Elbow, 90° - 1/2" O.D. Tube x 7/8"-14 Str. Thd. (Body Only)

REF.	PART NUMBER	QTY.	DESCRIPTION
47	12T61	1	Plug, Flared Tube, 37o Type Stl., 1/2" Tube O.D.
48	BA-876-5422W	1	Mount, Engine (Right Front)
49	BF-876-5422W	1	Mount, Engine (Left Front)
50	A-876-5423	2	Support, Pump Box (Rear)
51	26C47	12	5/8" x 1.25" Hex Head Cap Screw
52	27L59	8	5/8" Cut Washer
53	12Z46	4	5/8" Lock Nut
55	26C50	4	5/8" x 2" Hex Head Cap Screw
56	27L84	12	5/8" Lock Washer
57	28P34	1	Gear Box, Pump Drive (With Clutch) (See Section 12 For Breakdown)
58	27X83	1	Bearing, Pilot
59	27X79	12	3/8" x 1.25" Ferry Head Cap Screw
60	13M81	8	3/8" x 1.75" Hex Head Cap Screw (Grade 8)
61	27L78	20	3/8" Lock Washer
63	NV-17-9	6	Washer, Snubbing - 9/16" I.D. x 2" O.D. x 10 Ga. Stl.
64	16F90	4	Mount, Vibration (Rear)
65	27V90	2	Mount, Vibration (Front)
66	26A03	6	1/2" x 3.50" Hex Head Cap Screw
67	27L58	6	1/2" Cut Washer
68	12745	6	1/2" Lock Nut
69	10E10	12	3/8" x 1.25" Hex Head Cap Screw
70	12H23	12	3/8" Lock Nut
72	A-876-5222W	1	Sill, Engine
73	27L56	12	3/8" Cut Washer
	A-876-4768	1	Bracket, Throttle Cable
75	a 29S56	1	Sending Unit, Temperature
77	14J97	1	Sending Unit, Oil Pressure
79	29R13	1	Switch, Pressure (For Hour Meter)
80	20X30	2	Clamp, Hose
81	16F93	1	Cleaner, Air (Complete With Element) (Consisting in part of the following indented item):
	16F94	1	. Element, Air Cleaner
82	16L08	2	Band, Mounting
83	26E25	4	5/16" x .75" Hex Head Cap Screw
84	27C87	4	5/16" Nut
85	27L77	4	5/16" Lock Washer
86	28N91	1	Elbow, Molded - 45o x 3" I.D.
87	28N88	1	Elbow, Molded - 90o x 3.50" I.D. x 3" O.D. x 3.50"
89	29K60	3	Clamp, Hose
90	16L10	1	Cap, Air Cleaner
91	PB-876-5222W	1	Support, Air Cleaner
92	28N85	1	Shim, 1/8" (For Pilot Bearing)
93	28T18	1	Cap, Pipe
	10B23	3	Strap, Cable
	12X06	1	Switch, Engine Kill (Located on Operators Panel)
96	b 14131	1	Hose, 1/4" I.D. x 15'-0"
97	23M29	1	Connector, 1/4" Male N.P.T.F. x 1/4" I.D.
99	23D49	2	Connector, 1/4" I.D. Hose x 1/4" O.D. Tube
100	23C18	1	Elbow, 90o, 1/4" O.D. Tube x 1/4" N.P.T.

REF.	PART NUMBER	QTY.	DESCRIPTION
101	20N41	4	Clamp, Hose
102	23D29	2	Bushing, 3/8" x 1/4" N.P.T.
104	23F08	1	Elbow, 90° - 1/4" T. x 1/8" N.P.T.F.
105	DD-876-5223	1	Tubing x 1/4"
106	29K39	1	Muffler (With Clamp)
108	30M26	1	Cap, Rain
117	10E10	3	3/8" x 1.25" Hex Head Cap Screw
	MA-876-5287W	1	Cable, Battery (Positive)
	GF-876-5287W	1	Wire, Jumper
	26C97	1	3/8" External Tooth Lock Washer
132	DA-876-5224	1	Stack, Intake
133	DB-876-5224	1	Elbow, Air Cleaner
135	A-46-2030	1	Reducer, Hump - 3-1/2" O.D. x 3" I.D. x 3-3/4"
	26C53	1	3/8" x 1" Hex Head Cap Screw
139	26E24	2	1/2" x 1" Hex Head Cap Screw
140	27158	2	1/2" Cut Washer
141	27L81	4	1/2" Lock Washer
142	12Z45	2	1/2" Lock Nut
	27C90	1	3/8" Hex Nut
	27L78	1	3/8" Lock Washer

- a - Serviceable as a complete unit only.
- b - Be sure to specify length when ordering.

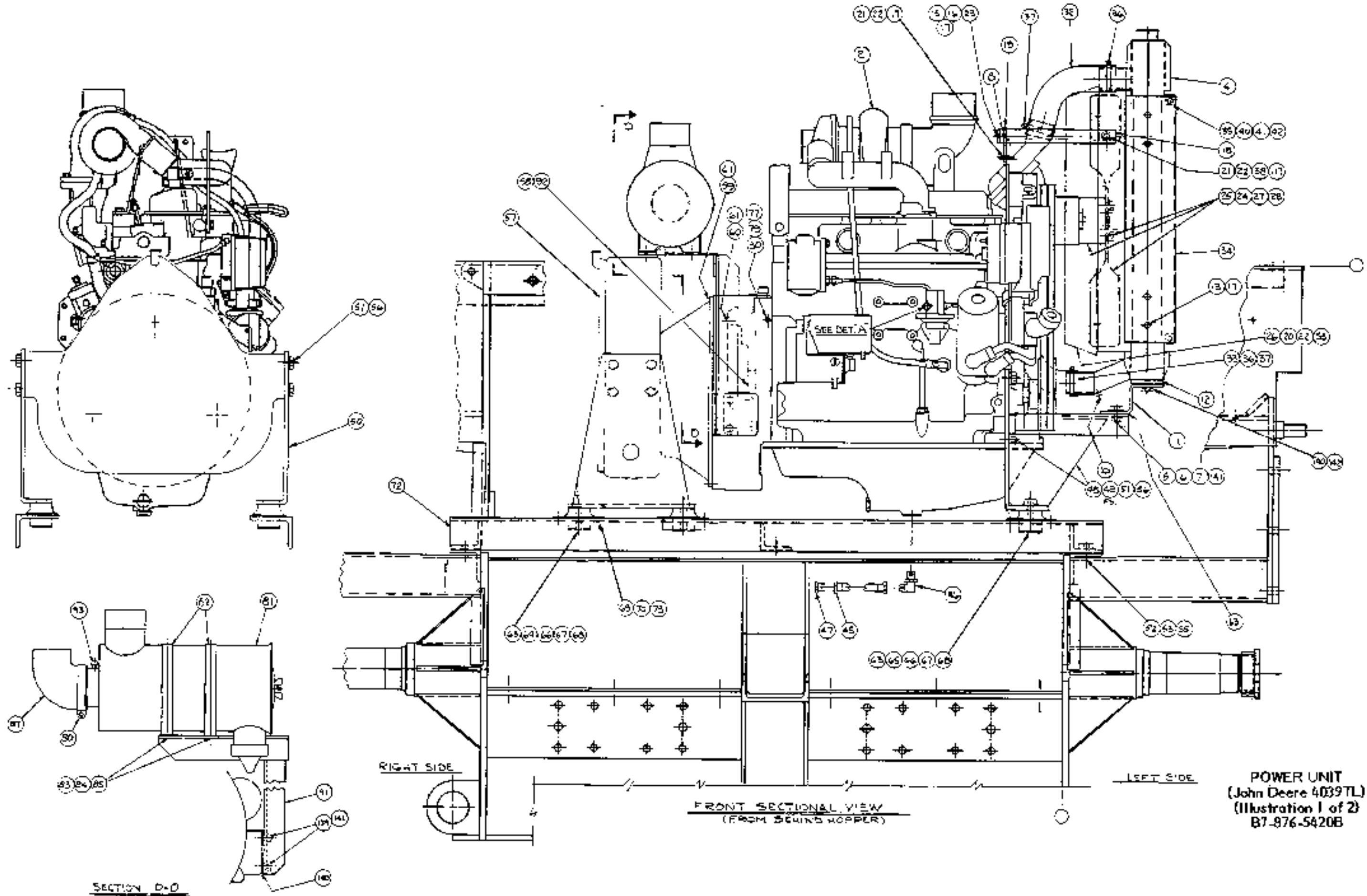

POWER UNIT
 (John Deere 4039TL)
 (Illustration 1 of 2)
 B7-876-5420B

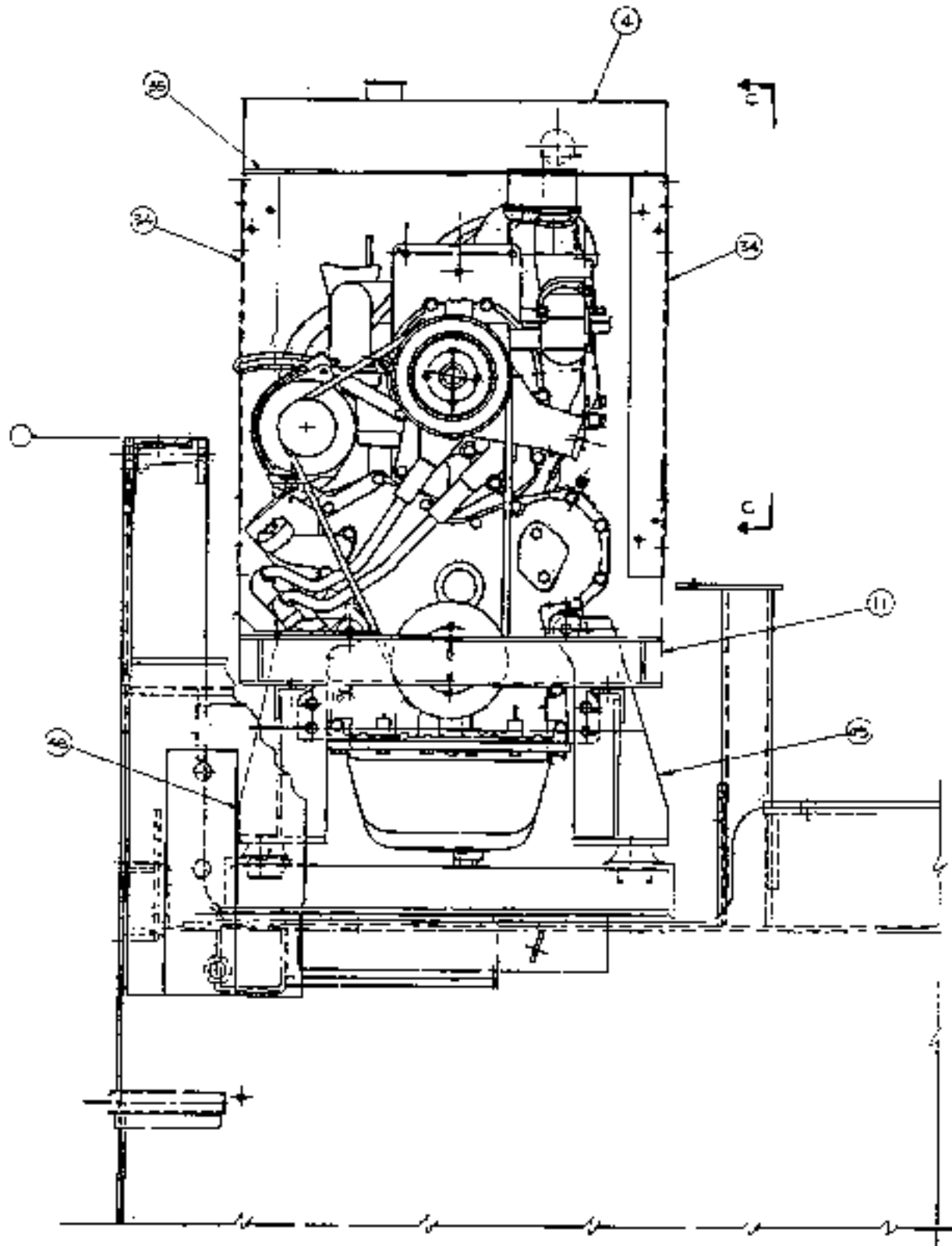

LEFT SIDE VIEW
(FRONT OF ENGINE)

POWER UNIT
(John Deere 4039TL)
(Illustration 2 of 2)
B7-876-5A20B

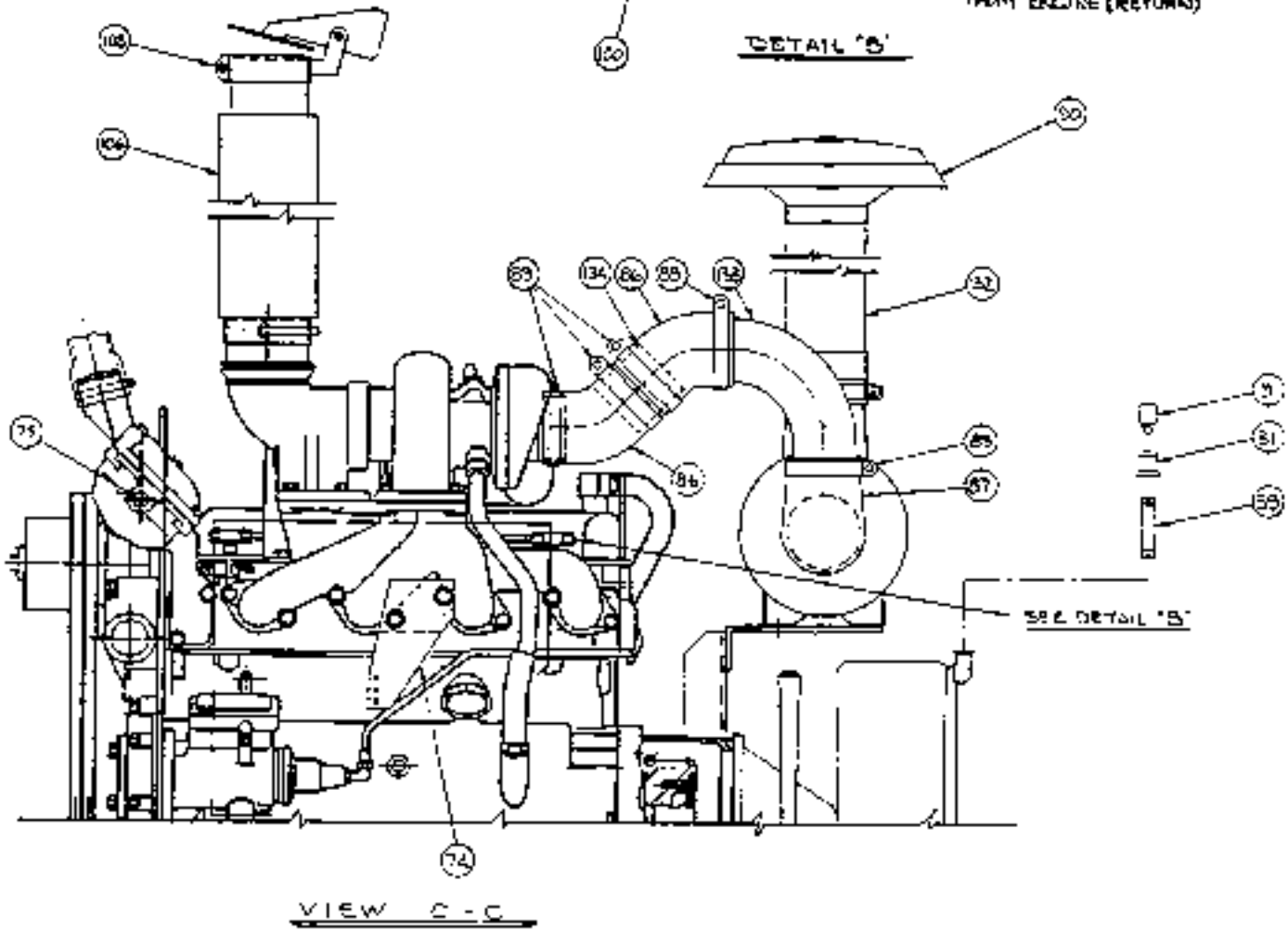
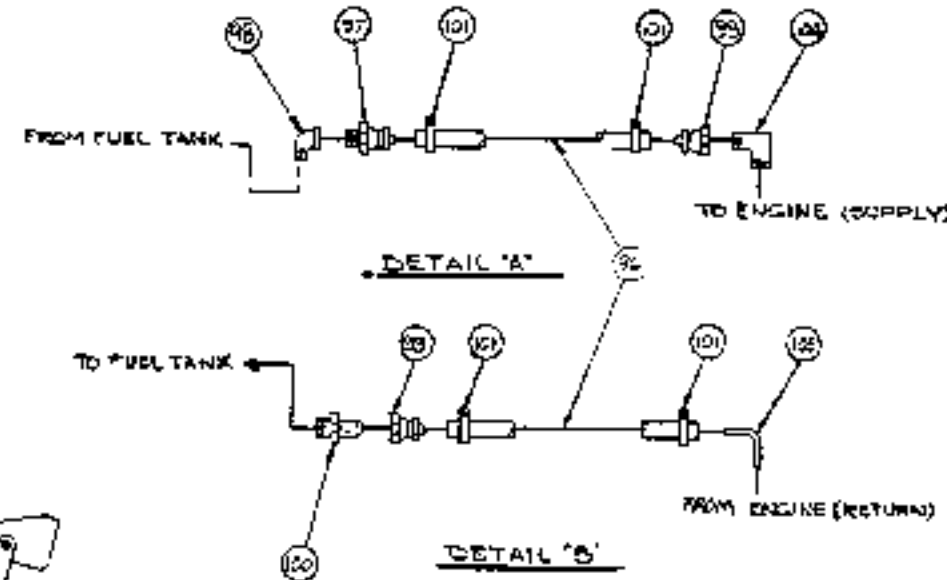

**POWER UNIT
(John Deere 4039TL)**

B7-876-5420B

(Before Ordering, Consult Table of Contents to Verify Proper Bill of Material Number.)

REF.	PART NUMBER	QTY.	DESCRIPTION
Ref. #2 thru #142 Symbolized by  on Illustrations 1 & 2.			
2	29L06	1	Engine, John Deere 4039TL (See Separate Manual) (Consisting in part of the following commonly ordered engine components):
	28G52C2	1	. Filter, Oil
	DEE-AR5004J	1	. Filter, Fuel
4	29M95	1	Radiator
5	26E29	2	1/2" x 1.50" Hex Head Cap Screw
6	27L58	4	1/2" Cut Washer
7	27C95	2	1/2" Hex Nut
8	J-876-4628	2	Pad, Radiator Support
9	23H7B	1	Filter, Breather
10	15G35	1	Valve, Drain
11	H-906-156B	1	Support, Bottom
12	CC-876-5224	1	Pad, Radiator
13	14L87	8	5/16" x .625" Hex Head Cap Screw
15	27L54	1	5/16" Cut Washer
16	27C87	1	5/16" Hex Nut
17	27L77	9	5/16" Lock Washer
18	EC-876-5423	1	Support, Radiator (Top)
19	H-876-4628	1	Bracket, Water Pump
20	26C53	4	3/8" x 1.00" Hex Head Cap Screw
21	27C90	3	3/8" Hex Nut
22	27L78	7	3/8" Lock Washer
23	23Y18	1	5/16" x 2.00" Hex Head Cap Screw
24	32A51	1	Fan, Suction
25	32A50	1	Spacer, Fan
26	29M94	1	Guard, Fan
27	23X08	4	3/8" x 3.50" Hex Head Cap Screw
28	27L78	4	3/8" Lock Washer
30	14T41	1	Tee, 1/8" Ma. x 1/8" Fe. x 1/8" Fe. N.P.T.F. Brass
31	23B39	1	Coupling, Reducer - 1/2" N.P.T. x 3/8" N.P.T.
32	23V18	1	Hose, Radiator (Top)
33	28K99	1	Hose, Radiator (Bottom)
34	EA-876-5222W	2	Mount, Oil Cooler
35	ED-876-5224	2	Baffle, Oil Cooler
36	23102	2	Clamp, Hose
37	23133	2	Clamp, Hose
38	27L56	6	3/8" Cut Washer
39	E-17-122	1	Nipple, 1/2" N.P.T. x 4"
40	13J31	4	1/4" x .75" Hex Head Cap Screw
41	27C86	4	1/4" Hex Nut
42	27L76	4	1/4" Lock Washer

REF.	PART NUMBER	QTY.	DESCRIPTION
45	R-80-481W	1	Hose Assembly, 1/2" x 36" (Oil Drain)
46	23R13	1	Elbow, 90° - 1/2" O.D. Tube x 7/8"-14 Str. Thd. (Body Only)
47	12T61	1	Plug, Flared Tube, 37° Type S1L, 1/2" Tube O.D.
48	BA-876-5422W	1	Mount, Engine (Right Front)
49	BF-876-5422W	1	Mount, Engine (Left Front)
50	A-876-5423	2	Support, Pump Box (Rear)
51	26C47	12	5/8" x 1.25" Hex Head Cap Screw
52	27L59	8	5/8" Cut Washer
53	12Z46	4	5/8" Lock Nut
55	26C50	4	5/8" x 2" Hex Head Cap Screw
56	27L84	12	5/8" Lock Washer
57	28P34	1	Gear Box, Pump Drive (With Clutch) (See Section 12 For Breakdown)
58	27X83	1	Bearing, Pilot
59	27X79	12	3/8" x 1.25" Ferry Head Cap Screw
60	13M81	8	3/8" x 1.75" Hex Head Cap Screw (Grade 8)
61	27L78	20	3/8" Lock Washer
63	NV-17-9	8	Washer, Snubbing - 9/16" I.D. x 2" O.D. x 10 Ga. Stl.
64	16F90	4	Mount, Vibration (Rear)
65	27V90	2	Mount, Vibration (Front)
66	26A03	6	1/2" x 3.50" Hex Head Cap Screw
67	27L58	6	1/2" Cut Washer
68	12Z45	6	1/2" Lock Nut
69	10E10	12	3/8" x 1.25" Hex Head Cap Screw
70	12H23	12	3/8" Lock Nut
72	A-876-5222W	1	Sill, Engine
73	27L56	12	3/8" Cut Washer
	A-876-4768	1	Bracket, Throttle Cable
75	a 29S56	1	Sending Unit, Temperature
77	14J97	1	Sending Unit, Oil Pressure
79	29R13	1	Switch, Pressure (For Hour Meter)
80	20X30	1	Clamp, Hose
81	16F93	1	Cleaner, Air (Complete With Element) (Consisting in part of the following indented item):
	16F94	1	• Element, Air Cleaner
82	16L08	2	Band, Mounting
83	26E25	4	5/16" x .75" Hex Head Cap Screw
84	27C87	4	5/16" Nut
85	27L77	4	5/16" Lock Washer
86	28N81	2	Elbow, Molded - 45° x 3" I.D.
87	28N88	1	Elbow, Molded - 90° x 3.50" I.D. x 3" O.D. x 3.50"
89	29K60	5	Clamp, Hose
90	16L10	1	Cap, Air Cleaner
91	RA-876-5222W	1	Support, Air Cleaner
92	28N85	1	Shim, 1/8" (For Pilot Bearing)
93	28T18	1	Cap, Pipe
	10B23	3	Strap, Cable
	12X06	1	Switch, Engine Kill (Located on Operators Panel)
96	b 14L31	1	Hose, 1/4" I.D. x 15'4ft
97	23M29	1	Connector, 1/4" Male N.P.T.F. x 1/4" I.D.

REF.	PART NUMBER	QTY.	DESCRIPTION
98	23C40	1	Elbow, 90° St. x 1/4" N.P.T.
99	23D49	2	Connector, 1/4" I.D. Hose x 1/4" O.D. Tube
101	20N41	4	Clamp, Hose
104	23F08	1	Elbow, 90° - 1/4" T. x 1/8" N.P.T.F.
105	DD-876-5223	1	Tubing x 1/4"
106	29K39	1	Muffler (With Clamp)
108	30M26	1	Cap, Rain
117	10E10	3	3/8" x 1.25" Hex Head Cap Screw
	MA-876-5287W	1	Cable, Battery (Positive)
	GF-876-5287W	1	Wire, Jumper
	26C97	1	3/8" External Tooth Lock Washer
132	DA-876-5224	1	Stack, Intake
133	DB-876-5224	1	Elbow, Air Cleaner
134	GE-876-5224	1	Tube, Air Cleaner
	26C53	1	3/8" x 1" Hex Head Cap Screw
139	26E28	2	1/2" x 1.25" Hex Head Cap Screw
140	27L58	6	1/2" Cut Washer
141	27L81	4	1/2" Lock Washer
142	12Z45	2	1/2" Lock Nut
	27C90	1	3/8" Hex Nut
	27L78	1	3/8" Lock Washer

- a - Serviceable as a complete unit only.
- b - Be sure to specify length when ordering.

**POWER UNIT
(Detroit Diesel 3-53N)**

C1-876-5420B

(Before Ordering, Consult Table of Contents to Verify Proper Bill of Material Number.)

REF.	PART NUMBER	QTY.	DESCRIPTION
	28G51	1	Engine, Detroit Diesel 3-53N (See Separate Manual) (Includes Radiator & Fan) (Consisting in part of the following commonly ordered engine components):
	WEN-25011011	1	. Element, Fuel Filter (Primary)
	WEN-25010959	1	. Element, Fuel Filter (Secondary)
	WEN-DDA25010495	1	. Filter, Oil
	JD-876-5223	2	Support, Oil Cooler
	KA-876-5223	2	End, Cooler Support
	26F25	2	5/16" x .75" Hex Head Cap Screw
	20X43	2	5/16" x 1/2" Hex Head Cap Screw
	27L54	4	5/16" Lock Washer
	27L77	4	5/16" Lock Washer
	13J28	4	1/4" x 1/2" Hex Head Cap Screw
	27L52	4	1/4" Cut Washer
	27L76	4	1/4" Lock Washer
	27C86	4	1/4" Hex Nut
	KB-876-5223	1	Bar, Engine Support (Front)
	JF-876-5223	2	Spacer, Mount (Front)
	13J37	4	1/2" x 1-3/4" Hex Head Cap Screw
	27L81	4	1/2" Lock Washer
	27C95	4	1/2" Hex Nut
	A-876-5423	2	Support, Pump Box (Rear)
	26C47	16	5/8" x 1-1/4" Hex Head Cap Screw
	27L84	8	5/8" Lock Washer
	23H78	1	Filter, Breather
	23B39	1	Coupling, Reducer - 1/2" N.P.T. x 3/8" N.P.T.
	28N83	1	Shim (For Pilot Bearing)
	28P34	1	Gear Box, Pump Drive (With Clutch) (See Section 12 For Breakdown)
	27X84	1	Bearing, Pilot
	27X79	12	3/8" x 1-1/4" Hex Head Cap Screw
	13M81	8	3/8" x 1-3/4" Hex Head Cap Screw (Grade 8)
	27L78	20	3/8" Lock Washer
	E-17-122	1	Nipple, 1/2" N.P.T. x 4"
	A-876-5222W	1	Sill, Engine
	NV-17-9	6	Washer, Snubbing - 9/16" I.D. x 2" O.D. x 10 Ga. S11.
	16F90	4	Mount, Vibration (Rear)
	27V90	2	Mount, Vibration (Front)
	26A03	6	1/2" x 3-1/2" Hex Head Cap Screw
	27L58	6	1/2" Cut Washer
	12Z45	6	1/2" Lock Nut
	13E10	12	3/8" x 1-1/4" Hex Head Cap Screw
	12H23	12	3/8" Lock Nut
	27L56	12	3/8" Cut Washer

REF.	PART NUMBER	QTY.	DESCRIPTION
	26C50	4	5/8" x 2" Hex Head Cap Screw
	17Z46	4	5/8" Lock Nut
	27L59	8	5/8" Cut Washer
	16F93	1	Cleaner, Air (Complete with Element) (Consisting in part of the following indented item):
	16F94	1	- Element, Air Cleaner
	16L08	2	Band, Mounting
	CA-876-5222W	1	Support, Air Cleaner
	23V67	8	5/16" x 1" Hex Head Cap Screw
	27L77	8	5/16" Lock Washer
	27C87	4	5/16" Hex Nut
	CB-876-5222W	1	Tube, Intake
	26W93	1	Elbow, 3-1/2" Molded
	23H34	2	Clamp, 3"
	16L10	1	Cap, Rain
	28T18	1	Cap, Pipe
	28H11	1	Muffler
	JC-876-5223	1	Support, Muffler
	KC-876-5223	1	Nipple, Exhaust Pipe
	16X73	1	Clamp, 3-1/2"
	14S35	1	Pipe, Exhaust, 3" I.D. x 36"
	31K69	1	Cap, Rain
	14S36	1	Clamp, 3"
	27V87	1	Alternator (55 AMP)
	12S67	1	Sheave
	23J75	1	Connector, 3/8" N.P.T. x 5/16" I.D. Hose
	23B66	1	Elbow, 90° - 3/8" N.P.T. x 5/16" I.D. Hose
	23G85	2	Elbow, 90° - 1/4" N.P.T. x 5/16" I.D. Hose
a	50N79	1	Hose, 5/16" I.D. x 10'-0"
	10B23	3	Strap, Cable
	JB-876-5223	1	Mount, Oil Filter
	10F10	6	3/8" x 1-1/4" Hex Head Cap Screw
	27L78	6	3/8" Lock Washer
	27C90	6	3/8" Hex Nut
	28F21	1	Tower (For Alternator)
	28F31	1	Terminal, Female (For Alternator)
	28F32	1	Seal, Cable (For Alternator)
	13M55	1	Switch, Engine Kill (Mounted on Operators Station Panel)
	MB-876-5222W	1	Hanger, Air Cleaner
	23Y18	2	5/16" x 2" Hex Head Cap Screw
	27L54	2	5/16" Cut Washer
	27L77	2	5/16" Lock Washer
	27C87	2	5/16" Hex Nut
	ZA-876-5223	1	Bracket, Support
	11N32	2	3/8" x 2" Hex Head Cap Screw
	27L78	2	3/8" Lock Washer
	27C90	2	3/8" Hex Nut
	11E30	1	1/4" External Tooth Lock Washer
	13J31	4	1/4" x .75" Hex Head Cap Screw
	27L52	4	1/4" Cut Washer

REF.	PART NUMBER	QTY.	DESCRIPTION
	27L76	4	1/4" Lock Washer
	27C86	4	1/4" Hex Nut
	28L45	1	Kit, Ether Starting
	20G93	1	Terminal
	20V68	1	Terminal, Bullet Receptacle
	F-46-2264	1	Nameplate
	LB-876-5067W	1	Wire
	LD-876-5067W	1	Wire
	XH-876-5287W	1	Harness, Starter
	XD-876-5287W	1	Harness, Engine

a - Be sure to specify length when ordering.

**ENGINE COVER
(For John Deere Engines)**

SI-876-5300B

(Before Ordering, Consult Table of Contents to Verify Proper Bill of Material Number.)

REF.	PART NUMBER	QTY.	DESCRIPTION
	CI-876-5303	1	Cover, Engine
	11N32	3	3/8" x 2" Hex Head Cap Screw
	27L56	5	3/8" Cut Washer
	27L78	5	3/8" Lock Washer
	26C53	2	3/8" x 1" Hex Head Cap Screw

**ENGINE COVER
(For John Deere Engines)**

B2-876-5300B

(Before Ordering, Consult Table of Contents to Verify Proper Bill of Material Number.)

REF.	PART NUMBER	QTY.	DESCRIPTION
	JA-876-5304	1	Cover, Engine
	11N32	6	3/8" x 2" Hex Head Cap Screw
	27L56	6	3/8" Cut Washer
	27L78	6	3/8" Lock Washer
	FB-876-5304	1	Cover, Engine (Front)
	27J97	7	#10-24 x .62" Round Head Machine Screw
	27C79	7	#10-24 Hex Nut
	27L99	7	#10 Lock Washer
	28T48	2	Support, Lid
	27K06	6	#10-32 x .62" Round Head Machine Screw
	13J33	6	#10-32 Lock Nut
	14B32	1	Latch, Draw
	27J97	2	#10-24 x .62" Round Head Machine Screw
	27K01	2	#10-24 x 1" Round Head Machine Screw
	27C79	4	#10-24 Hex Nut
	27L99	4	#10 Lock Washer

**ENGINE COVER
(For John Deere Engines)**

C2-876-5300B

(Before Ordering, Consult Table of Contents to Verify Proper Bill of Material Number.)

REF.	PART NUMBER	QTY.	DESCRIPTION
	FB-876-5304	1	Cover, Engine (Front)
	27J97	7	#10-24 x .62" Round Head Machine Screw
	27L99	7	#10 Lock Washer
	27C79	7	#10-24 Hex Nut
	28T48	2	Support, Lid
	27K06	6	#10-32 U.N.F. x .62" Round Head Machine Screw
	13J33	6	#10-32 U.N.F. Lock Nut
	14B32	1	Latch, Draw
	27K01	2	#10-24 x 1" Round Head Machine Screw
	27J97	2	#10-24 x .62" Round Head Machine Screw
	27L99	4	#10 Lock Washer
	27C79	4	#10-24 Hex Nut
	FA-876-5304	1	Cover, Engine
	11N32	6	3/8" x 2" Hex Head Cap Screw
	27L56	6	3/8" Cut Washer
	27L78	6	3/8" Lock Washer

**ENGINE COVER
(For John Deere Engines)**

C3-876-5300B

(Before Ordering, Consult Table of Contents to Verify Proper Bill of Material Number.)

REF.	PART NUMBER	QTY.	DESCRIPTION
	LE-876-5304	1	Cover, Engine (Front)
	27J97	7	#10-24 x .62" Round Head Machine Screw
	27L99	7	#10 Lock Washer
	27C79	7	#10-24 Hex Nut
	28T48	2	Support, Lid
	27K06	6	#10-32 U.N.F. x .62" Round Head Machine Screw
	13J33	6	#10-32 U.N.F. Lock Nut
	14B32	1	Latch, Draw
	27K01	2	#10-24 x 1" Round Head Machine Screw
	27J97	2	#10-24 x .62" Round Head Machine Screw
	27L99	4	#10 Lock Washer
	27C79	4	#10-24 Hex Nut
	SB-876-5304	1	Cover, Engine
	11N32	6	3/8" x 2" Hex Head Cap Screw
	27L56	6	3/8" Cut Washer
	27L78	6	3/8" Lock Washer

**ENGINE COVER
(For John Deere Engines)**

C4-876-5300B

(Before Ordering, Consult Table of Contents to Verify Proper Bill of Material Number.)

REF.	PART NUMBER	QTY.	DESCRIPTION
	HA-876-5503	1	Cover, Engine (Front)
	27J97	7	#10-24 x .62" Round Head Machine Screw
	27L99	7	#10 Lock Washer
	27C79	7	#10-24 Hex Nut
	E-876-5502W	1	Support, Lid
	27D48	1	Pin, Cotter - 3/32" x .75"
	14B32	1	Latch, Draw
	27K01	2	#10-24 x 1" Round Head Machine Screw
	27J97	2	#10-24 x .62" Round Head Machine Screw
	27L99	4	#10 Lock Washer
	27C79	4	#10-24 Hex Nut
	SB-876-5304	1	Cover, Engine
	11N32	6	3/8" x 2" Hex Head Cap Screw
	27L56	6	3/8" Cirr Washer
	27L78	6	3/8" Lock Washer

THROTTLE CONTROL
AI-876-SA2SB

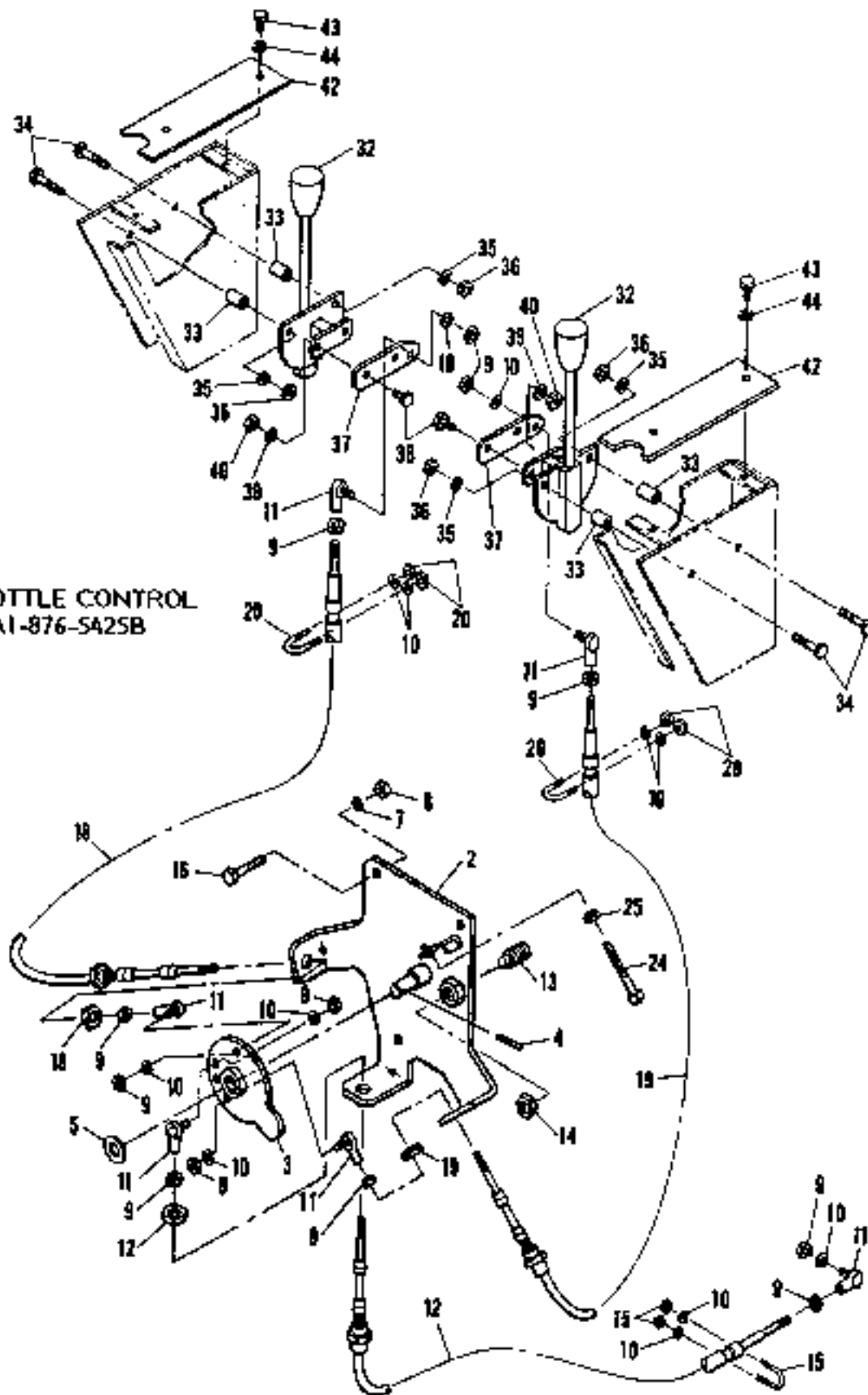

THROTTLE CONTROL

AI-876-5425B

(Before Ordering, Consult Table of Contents to Verify Proper Bill of Material Number.)

REF.	PART NUMBER	QTY.	DESCRIPTION
Ref. #2 thru #44 Symbolized by NONE on Illustration.			
2	AA-876-5052W	1	Support, Throttle Cable
3	AD-876-5052W	1	Lever, Cable Connector
4	50K71	1	Pin, Roll - 3/16" x 1-1/2"
5	27L60	1	3/4" Flat Washer
7	27L78	2	3/8" Lock Washer
8	27C90	2	3/8" Nut
9	27C85	12	1/4"-28 U.N.F. Nut
10	27L76	6	1/4" Lock Washer
11	11J48	6	Rod End, 1/4"
12	27Y18	1	Cable, Push-Pull x 38"
13	15W68	1	Detent
14	27D25	1	3/4"-10 Jam Nut
15	26A08	1	U-Bolt
16	11N32	2	3/8" X 2" Hex Head Cap Screw
18	28W60	1	Cable, Push-Pull (R.H.)
19	27Y17	1	Cable, Push-Pull (L.H.)
20	26A08	2	U-Bolt
24	27N08	1	3/8" x 3" Square Head Set Screw
25	27D17	1	3/8" Jam Nut
	10B23	4	Strap
32	28W39	2	Lever, Throttle
33	E-876-5428	4	Spacer
34	13M67	4	1/4" x 1.50" Hex Head Cap Screw
35	27L76	4	1/4" Lock Washer
36	27C86	4	1/4" Nut
37	B-876-5428	2	Lever
38	13J31	4	1/4" x .75" Hex Head Cap Screw
39	27L76	4	1/4" Lock Washer
40	27C86	4	1/4" Nut
42	KB-876-5304	2	Cover
43	26L55	4	1/4" x .62" Hex Head Cap Screw
44	27L76	4	1/4" Lock Washer

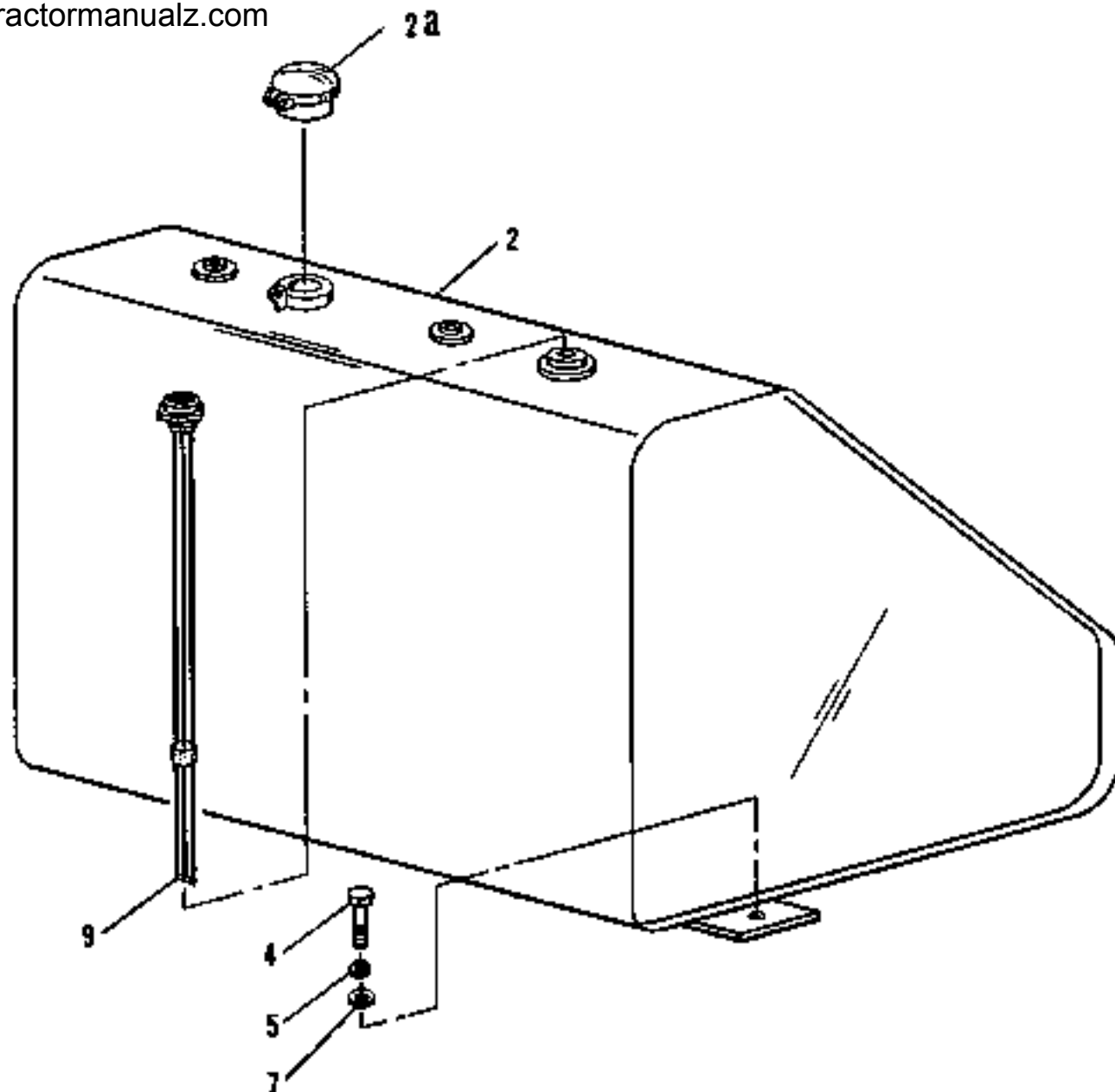

FUEL TANK

A1-876-5475B

(Before Ordering, Consult Table of Contents to Verify Proper Bill of Material Number.)

REF.	PART NUMBER	QTY.	DESCRIPTION
2	A1-876-5477W	1	Tank, Fuel (Consisting in part of the following indented items):
2A	SD-2302S016	1	• Cap, Fuel Filler
4	26E29	3	1/2" x 1-1/2" Hex Head Cap Screw
5	27L81	3	1/2" Lock Washer
7	27L58	3	1/2" Cut Washer
9	28T53	1	Sending Unit, Gauge

9/4/90 (1-2)

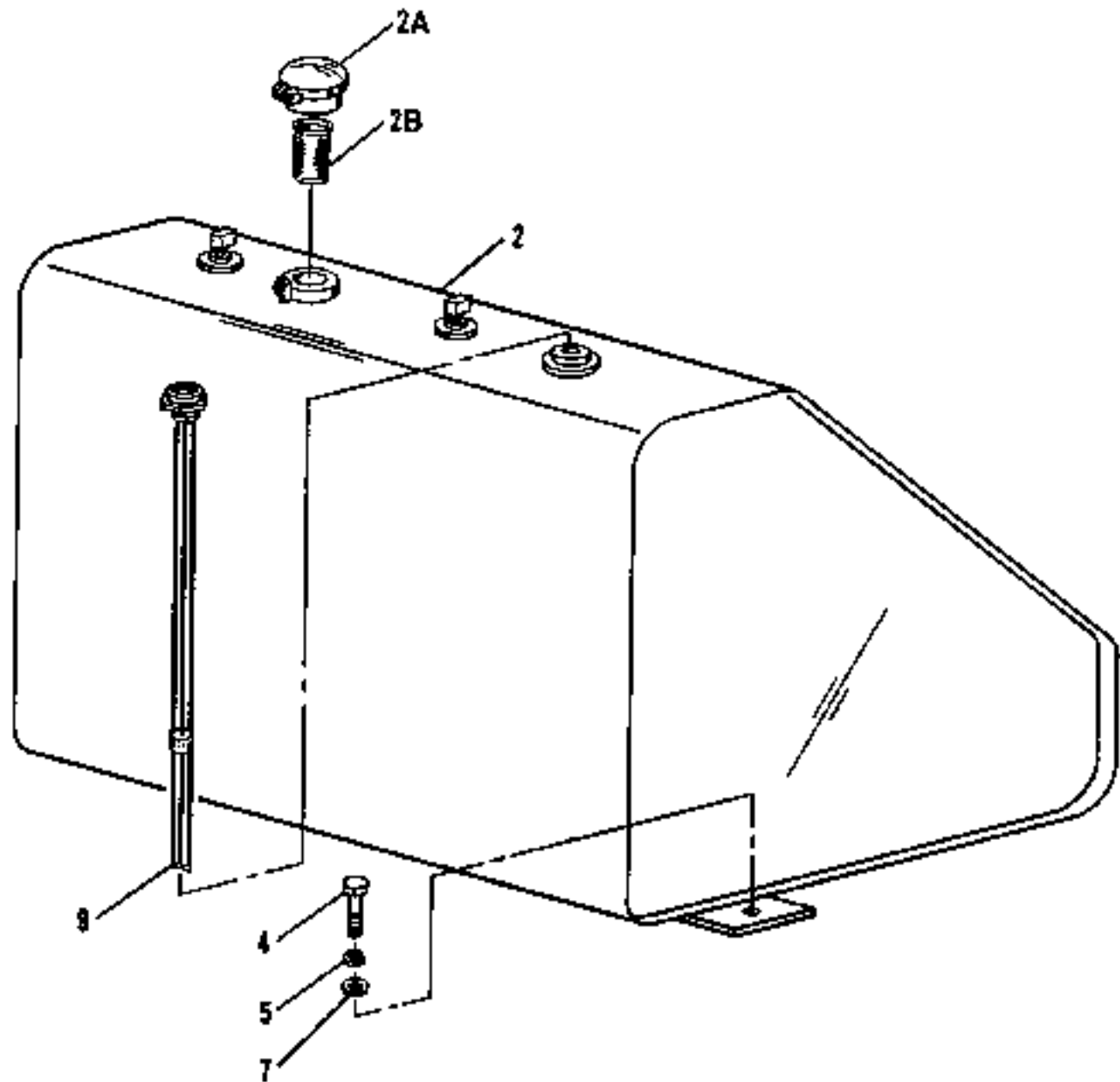

FUEL TANK

A2-876-5475B

(Before Ordering, Consult Table of Contents to Verify Proper Bill of Material Number.)

REF.	PART NUMBER	QTY.	DESCRIPTION
2	A2-876-5477W	1	Tank, Fuel (Consisting in part of the following indented item):
2A	SD-2302S016	1	. Cap, Fuel Filler
2B	DSM-212003	1	. Strainer
4	26E29	3	1/2" x 1-1/2" Hex Head Cap Screw
5	27L81	3	1/2" Lock Washer
7	27L58	3	1/2" Cut Washer
9	28753	1	Sending Unit, Gauge

8/1/91 (1-3)

SECTION 2

BG-220B Asphalt Paver

WHEEL DRIVE & BOGIE WHEELS

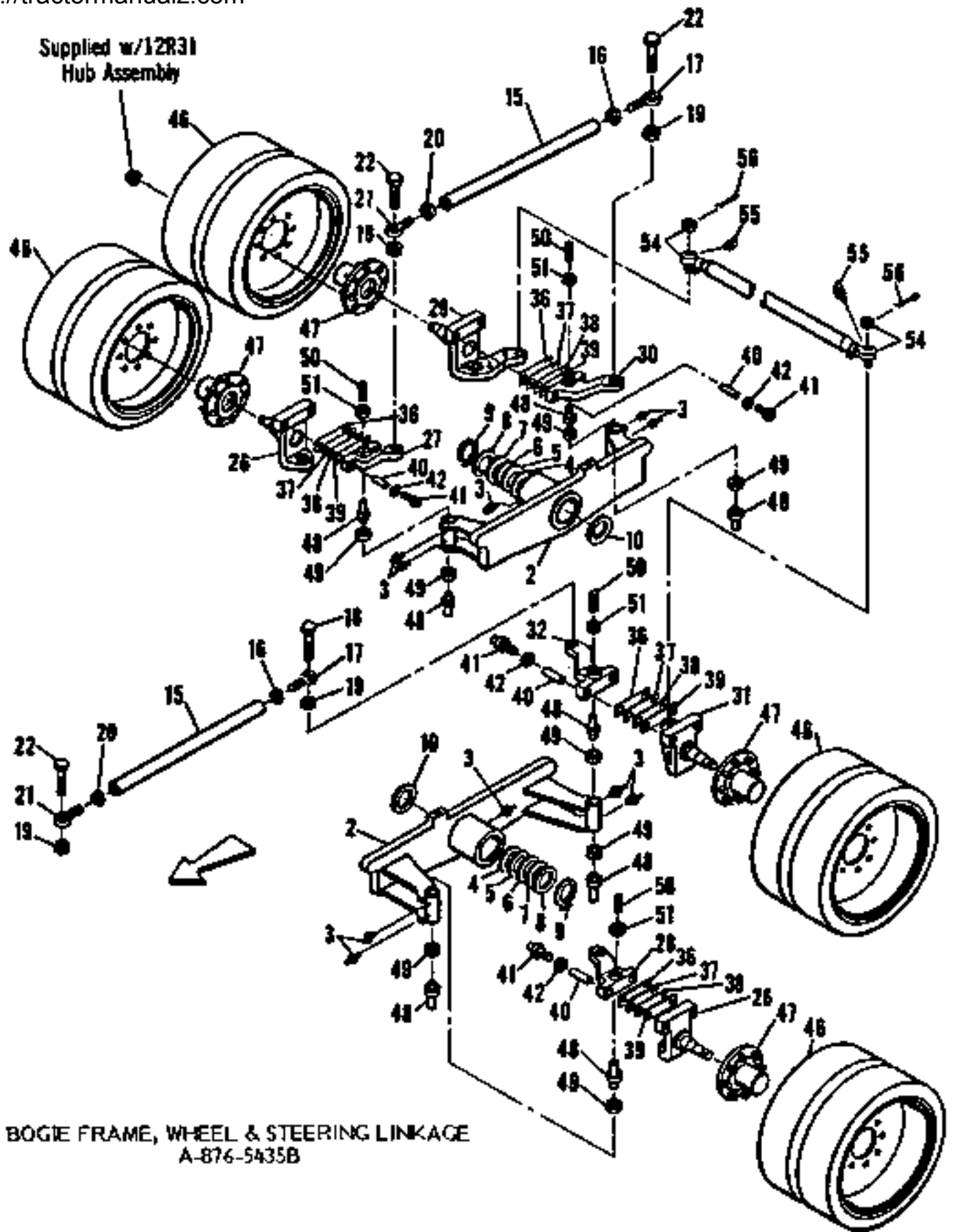

BOGIE FRAME, WHEEL & STEERING LINKAGE

A-876-5435B

(Before Ordering, Consult Table of Contents to Verify Proper Bill of Material Number.)

REF.	PART NUMBER	QTY.	DESCRIPTION
Ref. #2 thru #56 Symbolized by NONE on Illustration.			
2	A-876-5437W	2	Frame, Bogie (Each Frame Consisting in part of the following indented item):
	A-8-233	2	. Bushing
3	23C60	10	Fitting, 1/8" Hydraulic Lube (Straight)
4	AC-876-3023	4	Shim (16 ga.)
5	AD-876-3023	4	Shim (.020)
6	AE-876-3023	4	Shim (.010)
7	AF-876-3023	4	Shim (.005)
8	CT-17-478	2	3-21/32" I.D. Washer
9	10S56	2	Ring, Retaining
10	R-17-478	2	3-25/32" I.D. Washer
15	AC-876-5438	2	Rod, Relay
16	27D24	3	3/4"-16 Jam Nut (R.H.) (For 12P30)
17	12P30	3	Rod End (R.H.)
18	13T71	1	3/4" x 4-1/2" Hex Head Cap Screw
19	12Z47	4	3/4" Lock Nut
20	26E91	2	3/4"-16 Jam Nut (L.H.) (For 12P31)
21	12P31	2	Rod End (L.H.)
22	10E87	3	3/4" x 3-3/4" Hex Head Cap Screw
26	AA-876-3027W	2	Knuckle, Steering (Front)
27	PA-876-5438	1	Arm, Steering (Right Side Front)
28	PB-876-5438	1	Arm, Steering (Left Side Front)
29	DA-876-5437W	1	Knuckle, Steering (Right Side Rear)
30	GA-876-5438	1	Arm, Steering (Right Side Rear)
31	EA-876-5437W	1	Knuckle, Steering (Left Side Rear)
32	HA-876-5438	1	Arm, Steering (Left Side Rear)
36	A-876-1728	4	Shim (26 Ga.)
37	B-876-1728	4	Shim (20 Ga.)
38	C-876-1728	4	Shim (16 Ga.)
39	D-876-1728	4	Shim (10 Ga.)
40	A-876-3028	8	Sleeve
41	14G43	8	3/4" x 3" "C" Bore Screw
42	26B48	8	3/4" Washer (Hardened)
46	FA-876-5437W	4	Wheel, Bogie (12")
47	12P31	4	Hub Assembly
48	E-876-1728	8	Pin
49	12P97	8	Bearing
50	13Z38	4	3/4" x 1-3/4" Socket Head Set Screw
51	27D25	4	3/4" Jam Nut
54	27X88	1	Crossover Rod Assembly
55	23C66	2	Fitting, 1/8" Hydraulic Lube, 90°
56	27D55	2	Pin, 1/8" x 1-1/2" Cotter

REF.	PART NUMBER	QTY.	DESCRIPTION
------	-------------	------	-------------

The following six part numbers make up the steering arm stop which is located on the right side of the machine.

27D05	1	1" Hex Nut
27M05	1	1" Lock Washer
I2D38	1	1" x 3-1/2" Hex Head Cap Screw
FP-17-9	2	Washer, 1-1/32" I.D. x 2" O.D. x 3/8" Thk.
WS-17-9	2	Washer, 1-1/64" I.D. x 1-1/2" O.D. x #10 Thk.
JD-17-9	2	Washer, 1-1/32" I.D. x 1-7/8" O.D. x #16 Thk.

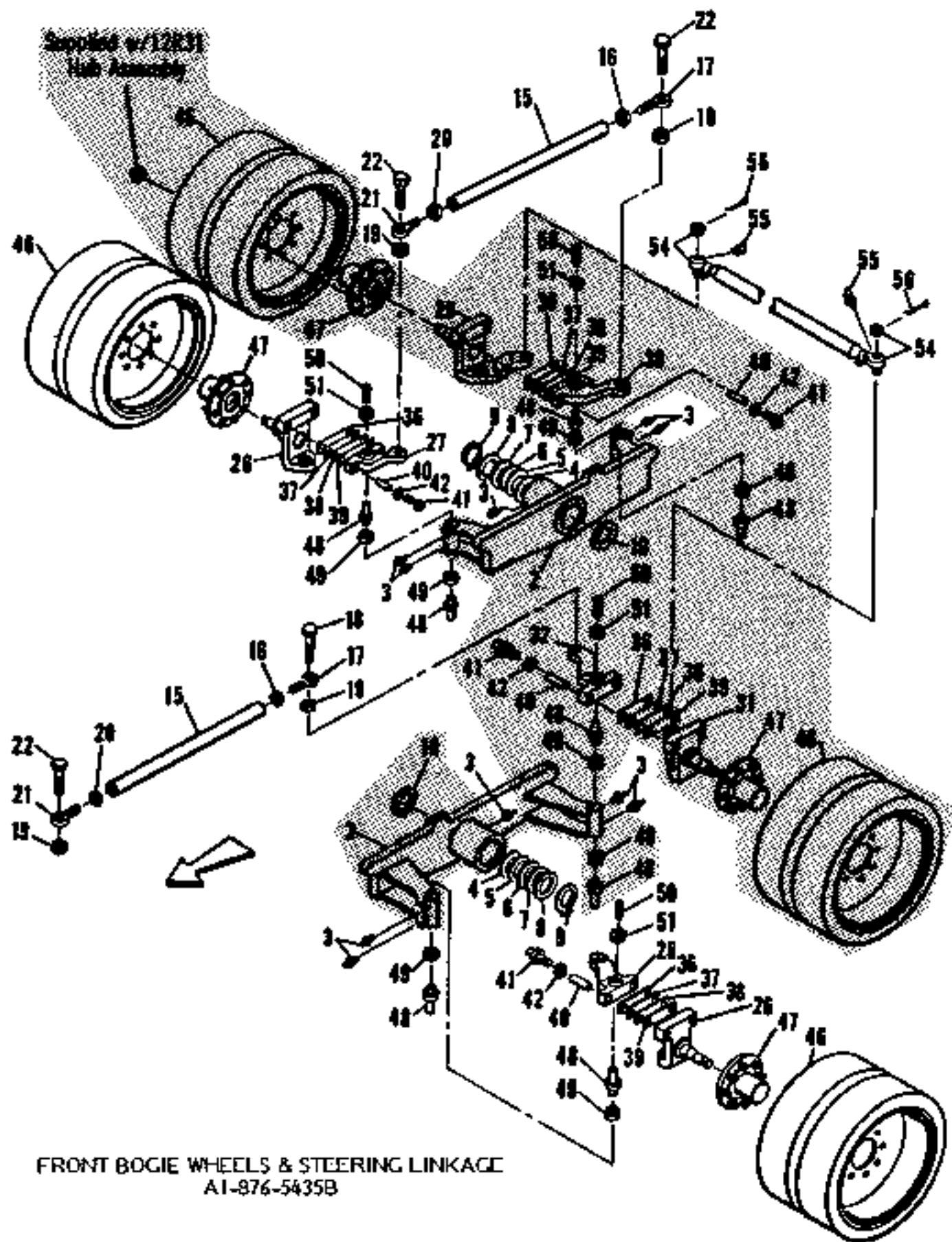

FRONT BOGIE WHEELS & STEERING LINKAGE
AI-876-5435B

FRONT BOGIE WHEELS & STEERING LINKAGE

A1-876-5435B

(Before Ordering, Consult Table of Contents to Verify Proper Bill of Material Number.)

REF.	PART NUMBER	QTY.	DESCRIPTION
Ref. #3 thru #56 Symbolized by NONE on Illustration.			
3	23C60	10	Fitting, 1/8" Hydraulic Lube (Straight)
4	AC-876-3023	4	Shim (16 ga.)
5	AD-876-3023	4	Shim (.020)
6	AE-876-3023	4	Shim (.010)
7	AF-876-3023	4	Shim (.005)
8	CT-17-478	2	3-21/32" I.D. Washer
9	10556	2	Ring, Retaining
15	AC-876-5438	2	Rod, Relay
16	27D24	3	3/4"-16 Jam Nut (R.H.) (For 12P30)
17	12P30	3	Rod End (R.H.)
18	13T7E	1	3/4" x 4-1/2" Hex Head Cap Screw
19	12Z47	4	3/4" Lock Nut
20	26E91	2	3/4"-16 Jam Nut (L.H.) (For 12P31)
21	12P31	2	Rod End (L.H.)
22	10E97	3	3/4" x 3-3/4" Hex Head Cap Screw
26	AA-876-3027W	2	Knuckle, Steering (Front)
27	PA-876-5438	1	Arm, Steering (Right Side Front)
28	PB-876-5438	1	Arm, Steering (Left Side Front)
36	A-876-1728	2	Shim (26 Ga.)
37	B-876-1728	2	Shim (20 Ga.)
38	C-876-1728	2	Shim (16 Ga.)
39	D-876-1728	2	Shim (10 Ga.)
40	A-876-3028	4	Sleeve
41	14G43	4	3/4" x 3" "C" Bore Screw
42	26B48	4	3/4" Washer (Hardened)
46	FA-876-5437W	2	Wheel, Bogie (12")
47	12R31	2	Hub Assembly
48	E-876-1728	4	Pin
49	12P97	4	Bearing
50	13Z38	2	3/4" x 1-3/4" Socket Head Set Screw
51	27D25	2	3/4" Jam Nut
54	27X88	1	Crossover Rod Assembly
55	23C66	2	Fitting, 1/8" Hydraulic Lube, 90°
56	27D55	2	Pin, 1/8" x 1-1/2" Cotter

The following six part numbers make up the steering arm stop which is located on the right side of the machine.

27D05	1	1" Hex Nut
27M05	1	1" Lock Washer
12D38	1	1" x 3-1/2" Hex Head Cap Screw
EA-17-478	2	Washer, 1-1/32" I.D. x 1-3/4" O.D. x 3/8" Thk.
WS-17-9	2	Washer, 1-1/64" I.D. x 1-1/2" O.D. x #10 Thk.
ED-17-478	2	Washer, 1-1/32" I.D. x 1-5/8" O.D. x #16 Thk.

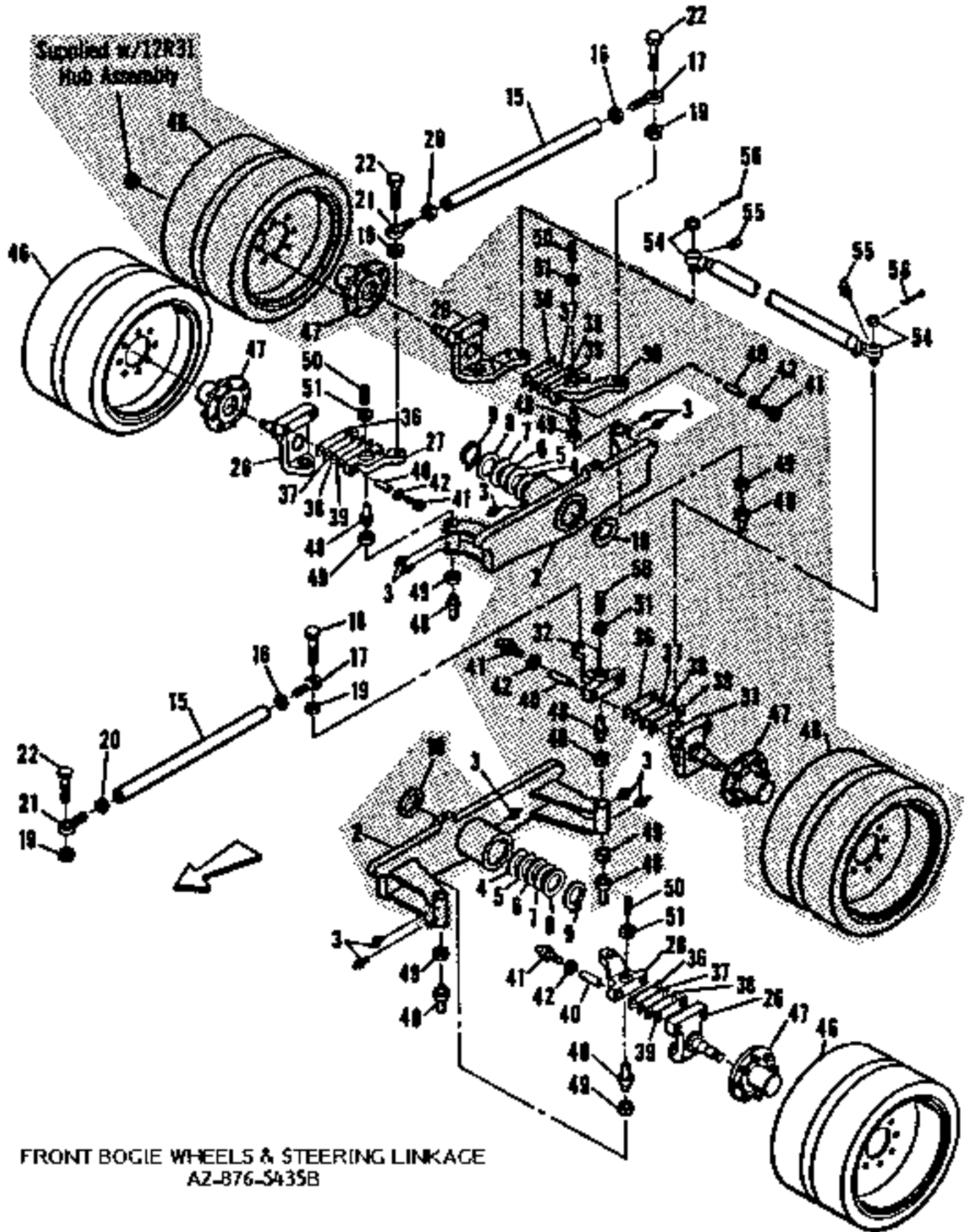

FRONT BOGIE WHEELS & STEERING LINKAGE

A2-876-5435B

(Before Ordering, Consult Table of Contents to Verify Proper Bill of Material Number.)

REF.	PART NUMBER	QTY.	DESCRIPTION
Ref. #3 thru #56 Symbolized by NONE on Illustration.			
3	23C60	10	Fitting, 1/8" Hydraulic Lube (Straight)
4	AC-876-3023	4	Shim (16 ga.)
5	AD-876-3023	4	Shim (.020)
6	AE-876-3023	4	Shim (.010)
7	AF-876-3023	4	Shim (.005)
8	CT-17-478	2	3-21/32" I.D. Washer
9	10556	2	Ring, Retaining
	27D24	1	3/4"-16 Jam Nut (R.H.) (For Steering Cylinder)
	12P30	1	Rod End (R.H.) (For Steering Cylinder)
15	AE-876-5438	2	Rod, Relay
16	27D26	2	7/8"-14 U.N.F. Hex Jam Nut (R.H.)
17	29L88	2	Rod End (R.H.)
18	13T71	1	3/4" x 4-1/2" Hex Head Cap Screw
19	12Z47	4	3/4" Lock Nut
20	29L86	2	7/8"-14 U.N.F. Hex Jam Nut (L.H.)
21	29L89	2	Rod End (L.H.)
22	10C87	3	3/4" x 3-3/4" Hex Head Cap Screw
26	AA-876-3027W	2	Knuckle, Steering (Front)
27	PA-876-5438	1	Arm, Steering (Right Side Front)
28	PB-876-5438	1	Arm, Steering (Left Side Front)
36	A-876-1728	2	Shim (26 Ga.)
37	B-876-1728	2	Shim (20 Ga.)
38	C-876-1728	2	Shim (16 Ga.)
39	D-876-1728	2	Shim (10 Ga.)
40	A-876-3028	4	Sleeve
41	14G43	4	3/4" x 3" "C" Bore Screw
42	26B48	4	3/4" Washer (Hardened)
46	FA-876-5437W	2	Wheel, Bogie (12")
47	12R31	2	Hub Assembly
48	E-876-1728	4	Pin
49	12P97	4	Bearing
50	13Z38	2	3/4" x 1-3/4" Socket Head Set Screw
51	27D25	2	3/4" Jam Nut
54	27X88	1	Crossover Rod Assembly
55	23C66	2	Fitting, 1/8" Hydraulic Lube, 90°
56	27D55	2	Pin, 1/8" x 1-1/2" Cotter

The following six part numbers make up the steering arm stop which is located on the right side of the machine.

27D05	1	1" Hex Nut
27M05	1	1" Lock Washer
12B38	1	1" x 3-1/2" Hex Head Cap Screw
EA-17-47E	2	Washer, 1-1/32" I.D. x 1-3/4" O.D. x 3/8" Thk.
WS-17-9	2	Washer, 1-1/64" I.D. x 1-1/2" O.D. x #10 Thk.
EB-17-478	2	Washer, 1-1/32" I.D. x 1-5/8" O.D. x #16 Thk.

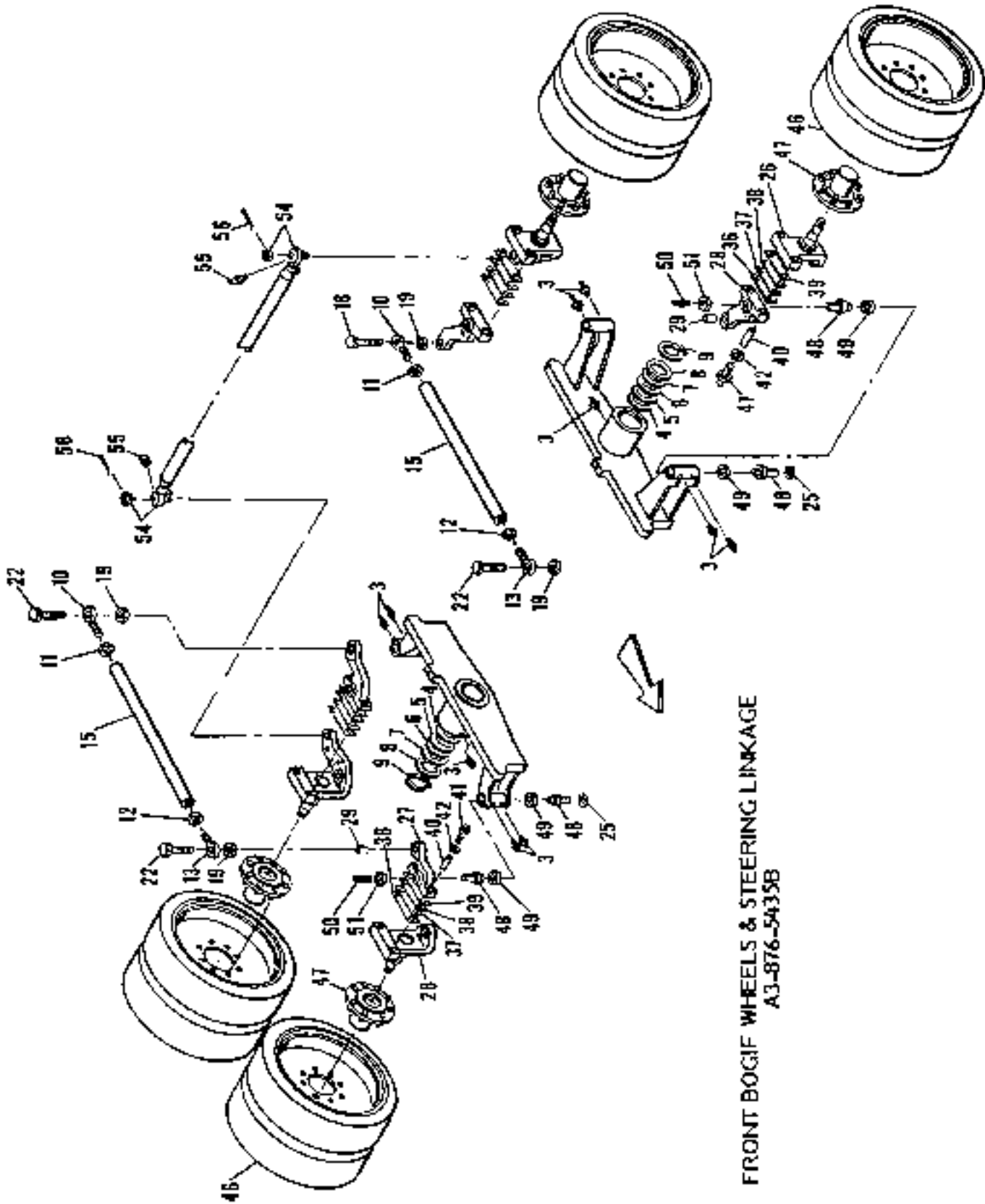

FRONT BOGIE WHEELS & STEERING LINKAGE
A3-876-5435B

FRONT BOGIE WHEELS & STEERING LINKAGE

A3-876-5435B

(Before Ordering, Consult Table of Contents to Verify Proper Bill of Material Number.)

REF.	PART NUMBER	QTY.	DESCRIPTION
Ref. #3 thru #56 Symbolized by NONE on Illustration.			
3	23C60	10	Fitting, 1/8" Hydraulic Lube (Straight)
4	AC-876-3023	4	Shim (16 ga.)
5	AD-876-3023	4	Shim (.020)
6	AE-876-3023	4	Shim (.010)
7	AF-876-3023	4	Shim (.005)
8	CT-17-478	2	3-21/32" I.D. Washer
9	10556	2	Ring, Retaining
10	29L88	2	Rod End (R.H.)
11	27D26	2	7/8"-14 U.N.F. Hex Jam Nut (R.H.)
12	29L86	2	7/8"-14 U.N.F. Hex Jam Nut (L.H.)
13	29L89	2	Rod End (L.H.)
15	AE-876-5438	2	Rod, Relay
16	27D24	1	3/4"-16 U.N.F. Jam Nut (R.H.)
17	29P19	1	Rod End (R.H.)
18	13T71	1	3/4" x 4-1/2" Hex Head Cap Screw
19	12Z47	4	3/4" Lock Nut
22	10E87	3	3/4" x 3-3/4" Hex Head Cap Screw
25	QG-17-9	2	Washer, 1.31" I.D. x .19" Thick
26	GB-876-5439W	2	Knuckle, Steering (Front)
27	FB-876-5439	1	Arm, Steering (Right Side Front)
28	FC-876-5439	1	Arm, Steering (Left Side Front)
29	29M38	2	Bushing, 3/4" I.D. x 1.62"
36	A-876-1728	2	Shim (26 Ga.)
37	B-876-1728	2	Shim (20 Ga.)
38	C-876-1728	2	Shim (16 Ga.)
39	D-876-1728	2	Shim (10 Ga.)
40	A-876-3028	4	Sleeve
41	14C43	4	3/4" x 3" "C" Bore Screw
42	26D40	4	3/4" Washer (Hardened)
46	FA-876-5437W	2	Wheel, Bogie (12")
47	12R31	2	Hub Assembly
48	ED-876-5439	4	Pin
49	29M33	4	Bushing Assembly (Heavy Duty)
50	13Z38	2	3/4" x 1-3/4" Socket Head Set Screw
51	27D25	2	3/4" Jam Nut
54	27X88	1	Crossover Rod Assembly
55	23C66	2	Fitting, 1/8" Hydraulic Lube, 90°
56	27D55	2	Pin, 1/8" x 1-1/2" Cutter

The following six part numbers make up the steering arm stop which is located on the right side of the machine.

27D05 1 1" Hex Nut

5/1/90 (1.0-8)

SECTION 2 PAGE 9

(Continued)

REF.	PART NUMBER	QTY.	DESCRIPTION
	27M05	1	1" Lock Washer
	12B38	1	1" x 3-1/2" Hex Head Cap Screw
	CA-17-478	2	Washer, 1-1/32" I.D. x 1-3/4" O.D. x 3/8" Thk.
	WS-17-9	2	Washer, 1-1/64" I.D. x 1-1/2" O.D. x #10 Thk.
	ED-17-478	2	Washer, 1-1/32" I.D. x 1-5/8" O.D. x #16 Thk.

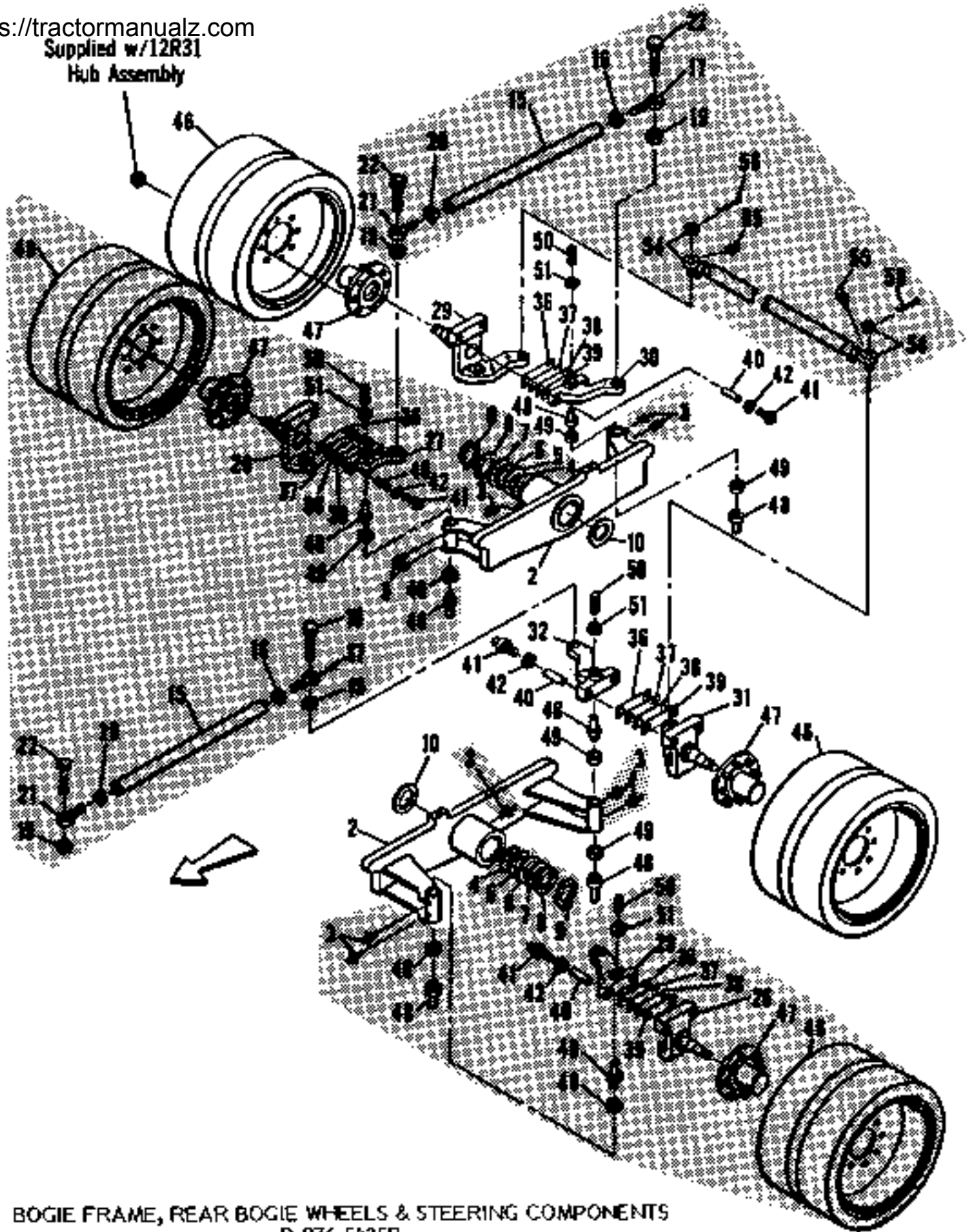

BOGIE FRAME, REAR BOGIE WHEELS & STEERING COMPONENTS
B-876-5135B

BOGIE FRAME, REAR BOGIE WHEELS & STEERING COMPONENTS

B-876-5435B

(Before Ordering, Consult Table of Contents to Verify Proper Bill of Material Number.)

REF.	PART NUMBER	QTY.	DESCRIPTION
Ref. #2 thru #51 Symbolized by NONE on Illustration.			
2	A-876-5437W	2	Frame, Bogie (Each Frame Consisting in part of the following indented item):
	A-8-233	2	• Bushing
10	R-17-478	2	3-25/32" I.D. Washer
29	DA-876-5437W	1	Knuckle, Steering (Right Side Rear)
30	GA-876-5438	1	Arm, Steering (Right Side Rear)
31	EA-876-5437W	1	Knuckle, Steering (Left Side Rear)
32	HA-876-5438	1	Arm, Steering (Left Side Rear)
36	A-876-1728	2	Shim (26 Ga.)
37	B-876-1728	2	Shim (20 Ga.)
38	C-876-1728	2	Shim (16 Ga.)
39	D-876-1728	2	Shim (10 Ga.)
40	A-876-3028	4	Sleeve
41	14G43	4	3/4" x 3" "C" Bore Screw
42	26B48	4	3/4" Washer (Hardened)
46	GA-876-5437W	2	Wheel, Bogie (12")
47	12R31	2	Hub Assembly
48	E-876-1728	4	Pin
49	12F97	4	Bearing
50	13Z38	2	3/4" x 1-3/4" Socket Head Set Screw
51	27D25	2	3/4" Jam Nut

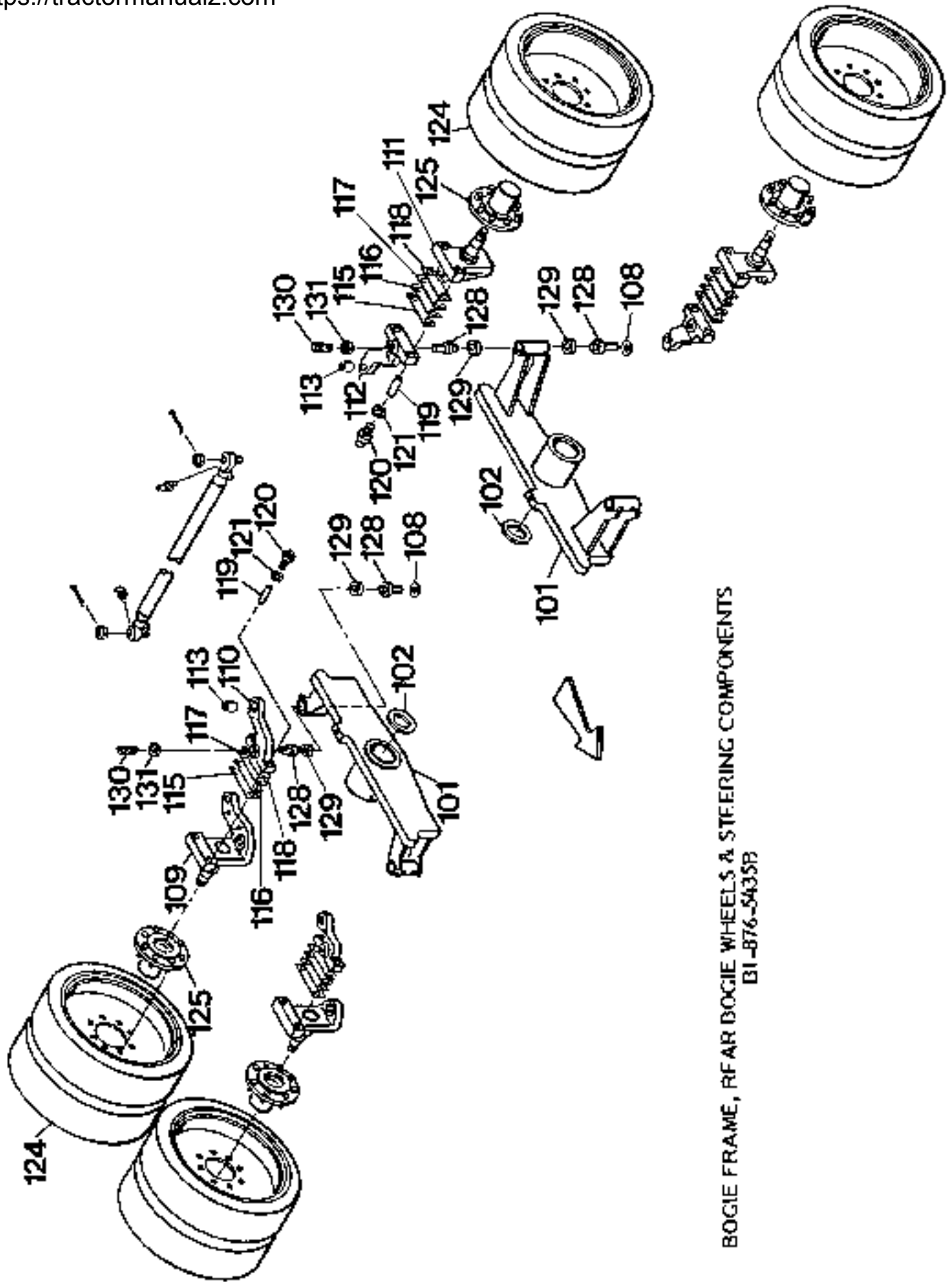

BOGIE FRAME, REAR BOGIE WHEELS & STEERING COMPONENTS
BI-876-5435B

BOGIE FRAME, REAR BOGIE WHEELS & STEERING COMPONENTS

BI-876-5435B

(Before Ordering, Consult Table of Contents to Verify Proper Bill of Material Number.)

REF.	PART NUMBER	QTY.	DESCRIPTION
Ref. #101 thru #131 Symbolized by NONE on Illustration.			
101	AI-876-5437W	2	Frame, Bogie (Each Frame Consisting in part of the following indented items):
	A-8-233	2	. Bushing
102	R-17-478	2	Washer, 3.79" I.D.
108	OQ-17-9	2	Washer, 1.31" I.D. x .19" Thick
109	GA-876-5439W	1	Knuckle, Steering (Right Side Rear)
110	EB-876-5439	1	Arm, Steering (Right Side Rear)
111	HA-876-5439W	1	Knuckle, Steering (Left Side Rear)
112	EA-876-5439	1	Arm, Steering (Left Side Rear)
113	29M34	2	Bushing, 3/4" I.D. x 1.75"
115	A-876-1728	2	Shim (26 Ga.)
116	B-876-1728	2	Shim (20 Ga.)
117	C-876-1728	2	Shim (16 Ga.)
118	D-876-1728	2	Shim (10 Ga.)
119	A-876-3028	4	Sleeve
120	14G43	4	3/4" x 3" "C" Bare Screw
121	26B48	4	3/4" Washer (1 hardened)
124	FA-876-5437W	2	Wheel, Bogie (12")
125	12R31	2	Hub Assembly
128	ED-876-5439	4	Pin
129	29M33	4	Bushing Assembly
130	13Z38	2	3/4" x 1-3/4" Socket Head Set Screw
131	27D25	2	3/4" Jam Nut

FRONT WHEEL DRIVE PACKAGE
(Bogie Wheel Steering Assembly)
(Illustration 1 of 3)
C-876-5435B

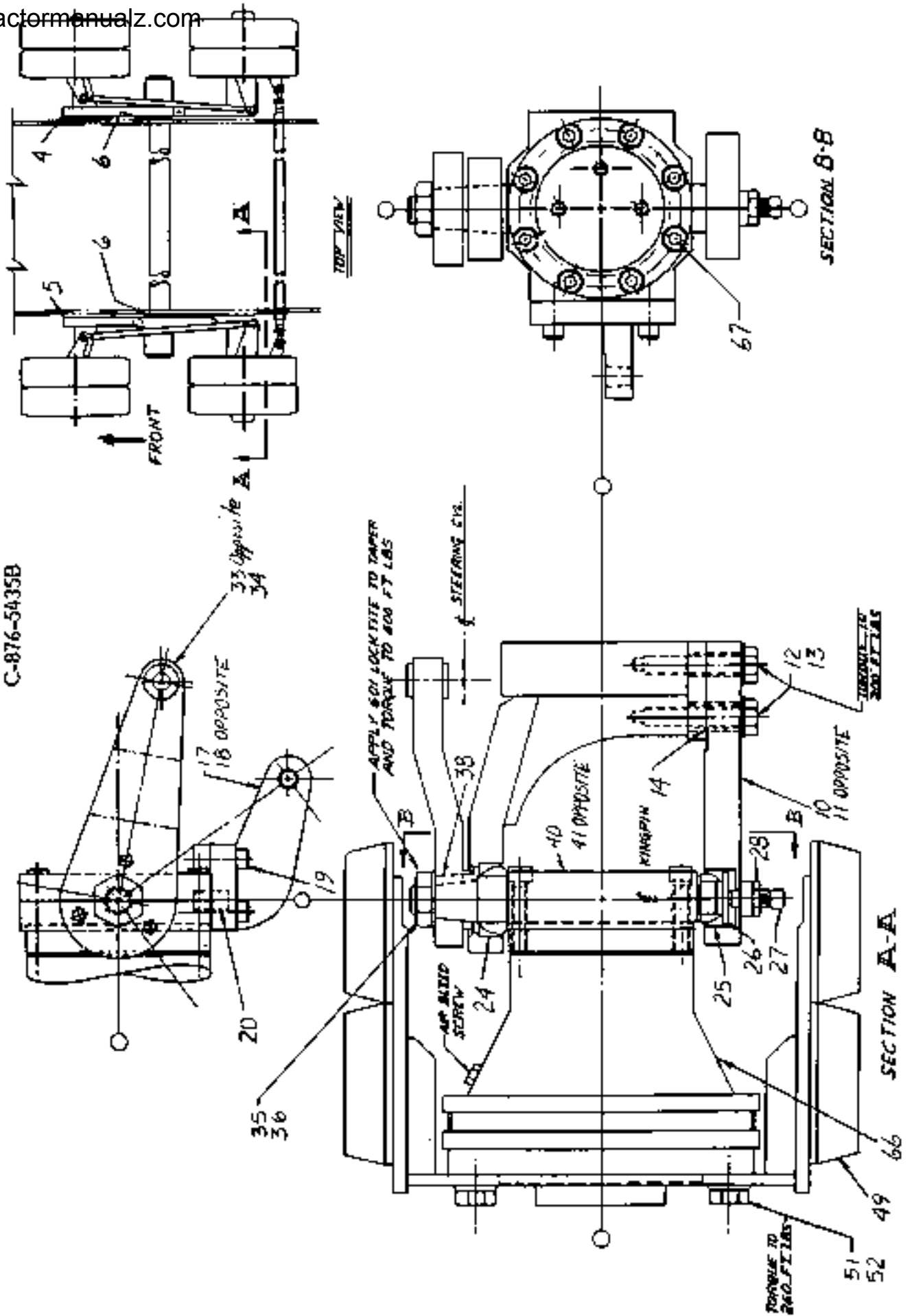

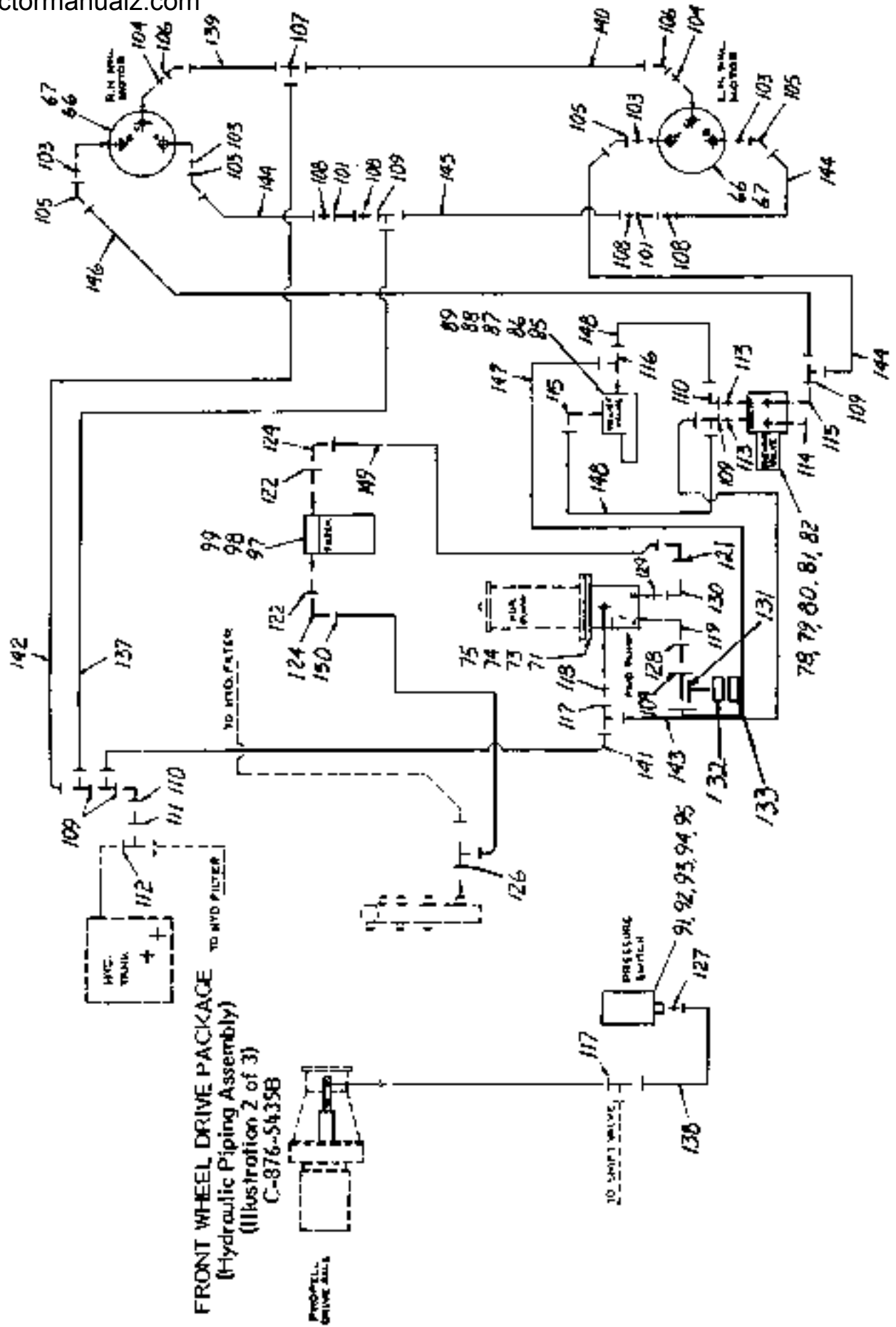

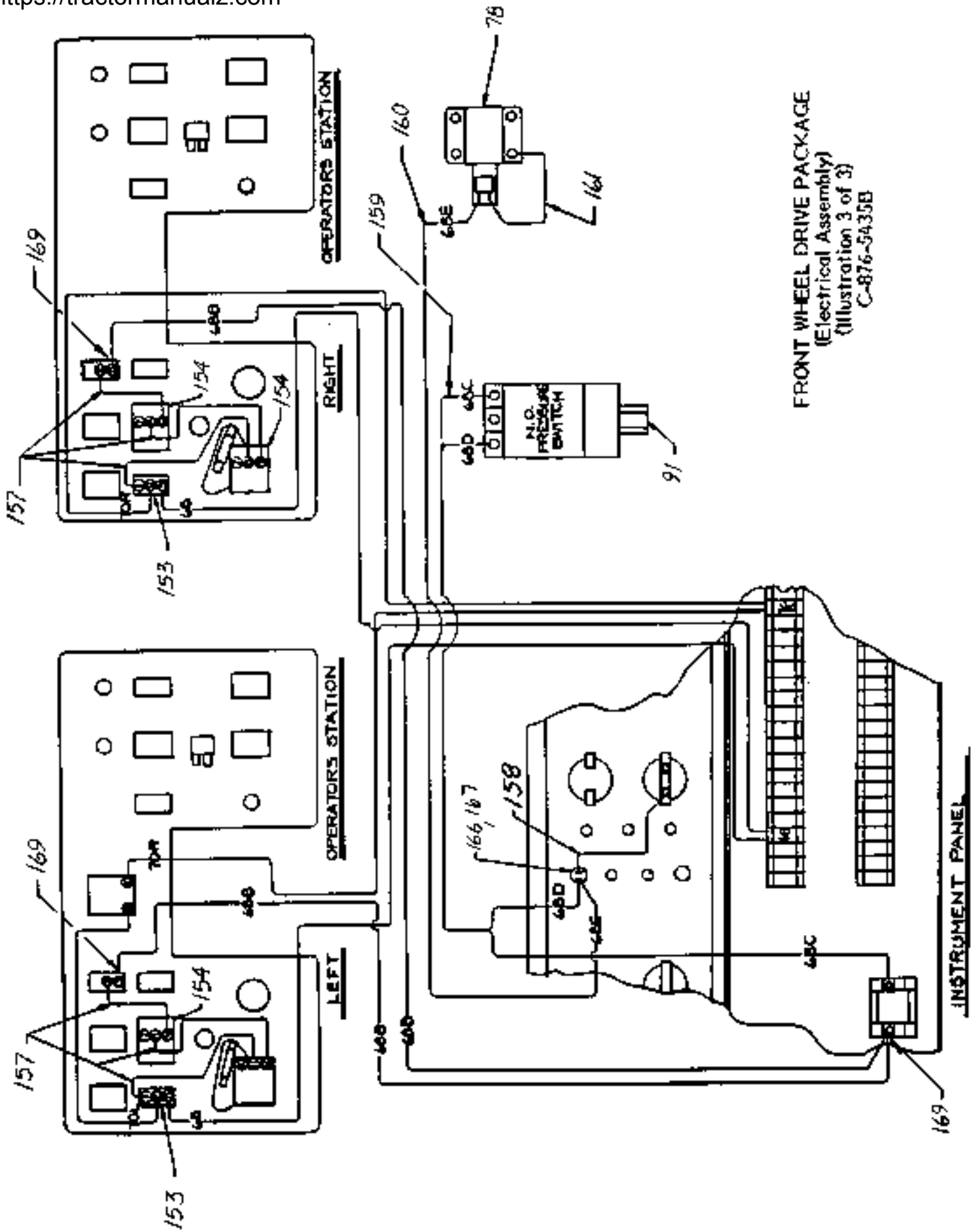

FRONT WHEEL DRIVE PACKAGE
(Electrical Assembly)
(Illustration 3 of 3)
C-876-5A35B

FRONT WHEEL DRIVE PACKAGE
(Bogie Wheel Steering, Hydraulic Piping & Electrical Components)

C-876-5435B

(Before Ordering, Consult Table of Contents to Verify Proper Bill of Material Number.)

REF.	PART NUMBER	QTY.	DESCRIPTION
Ref. #4 thru #169 Symbolized by NONE on Illustrations 1, 2 & 3.			
4	SA-876-5437W	1	Frame, Bogie (Right Side)
5	TA-876-5437W	1	Frame, Bogie (Left Side)
6	DY-17-478	2	Washer, 3.78" I.D. x .12" Thick
10	KA-876-5437W	1	Bracket, Lower Arm (Left Side)
11	KB-876-5437W	1	Bracket, Lower Arm (Right Side)
12	26E27	8	3/4" x 3.50" Hex Head Cap Screw
13	26B48	8	3/4" Hardened Washer
14	26L17	4	Bushing, 2" Tension
17	JA-876-5437W	1	Arm, Steering (Left Side) (Rear)
18	JB-876-5437W	1	Arm, Steering (Right Side) (Rear)
19	11L72	8	5/8" x 1.75" Counter Bore Cap Screw
20	26S51	2	Pin, Dowel - .75" Diameter x 1.50"
24	23W42	2	Thrust Bushing Assembly - 2" Diameter
25	28W64	2	Thrust Bushing Assembly - 1.5" Diameter
26	RE-876-5438	2	Plate, Bearing Adjusting
27	13Z38	2	3/4" x 1.75" Socket Head Set Screw
28	27D25	2	3/4" Jam Nut
33	LA-876-5437W	1	Arm, Steering (Right Side) (Rear)
34	LB-876-5437W	1	Arm, Steering (Left Side) (Rear)
35	28W66	2	1-1/4" Shaft Nut
36	28W65	2	Shaft Nut Washer
38	B-17-476	2	Key, Hardened - .50" Square x 1.56"
40	PA-876-5437W	1	Kingpin (Left Side) (Rear)
41	RA-876-5437W	1	Kingpin (Right Side) (Rear)
47	A-46-2299	1	Decal "CAUTION - TO PREVENT UNEXPECTED MACHINE MOVEMENT PLACE F.W.D. SWITCH IN "OFF" POSITION BEFORE LEAVING OPERATORS AREA OR SERVICING MACHINE"
49	VA-876-5437W	2	Wheel & Tire Assembly (22" Diameter x 12" Wide)
51	28W62	16	M20 x 1.5" x 35 Class 12.9 Hex Head Cap Screw
52	28W71	16	M20 Hardened Washer
	WD-876-5438	1	Support, Valve
	WE-876-5438	1	Support, Switch
66 a	28W74	2	Motor, Hydraulic (Wheel)
67	28W63	16	M16 x 2" x 70 Class 12.9 Socket Head Cap Screw
71 a	20V80	1	Pump, Hydraulic - Variable Displacement - Pressure Compensating
73	26C57	2	1/2" x 2.75" Hex Head Cap Screw
74	C-17-478	2	Washer, 1/2" x .25"
75	27L81	2	1/2" Lock Washer
	27C95	2	1/2" Hex Nut
	A-53-2517	1	Gasket

REF.	PART NUMBER	QTY.	DESCRIPTION
78 a	28W75	1	Valve, Solenoid - 4 Way
79	26C69	4	1/4" x 1" Hex Head Cap Screw
80	27L76	4	1/4" Lock Washer
81	27C86	4	1/4" Hex Nut
82	27L52	4	1/4" Washer
85 a	28W69	1	Valve, Hydraulic Relief (3500 PSI)
86	27L76	2	1/4" Lock Washer
87	27C86	2	1/4" Hex Nut
88	27L52	2	1/4" Washer
89	16W90	2	1/4" x 2" Hex Head Cap Screw
91	28W67	1	Switch, Pressure
92	27K01	2	#10-24 x 1" Round Head Machine Screw
93	27L71	2	#10 Washer
94	27L99	2	#10 Lock Washer
95	27C79	2	#10-24 Nut
97	16W35	1	Filter, Hydraulic (Consisting in part of the following indented items):
	16X52	1	. Element, Filter
98	26E25	4	5/16" x .75" Hex Head Cap Screw
99	27L77	4	5/16" Lock Washer
101	28W70	2	Valve, Check
103	28W72	4	Adapter, 3/4" BSPP x 1/2" T.
104	28W68	2	Adapter, 3/8" BSPP x 3/8" T.
105	28Y46	4	Elbow, 45° - 1/2" T. Swivel
106	28Y47	2	Elbow, 45° - 3/8" T. Swivel
107	12X40	1	Tee, 3/8" T.
108	23L74	4	Adapter, 1/2" N.P.T.F. x 1/2" T.
109	13J69	6	Tee, 1/2" T. Swivel
110	15B83	2	Elbow, 90° - 1/2" T. Swivel
111	14P90	1	Reducer, Tube End - 1-1/4" T. To 1/2" T.
112	14T60	1	Tee, 1-1/4" T. Swivel
113	23H54	2	Adapter, 1/2" T. x 3/4"-16, O-Ring
114	23H55	1	Plug, 3/4"-16, O-Ring
115	23P99	2	Elbow, 90° - 1/2" T. x 3/4"-16, O-Ring
116	23R60	1	Tee, 1/2" T. x 3/4"-16, O-Ring
117	23T03	2	Tee, 3/8" T. Swivel
118	23R04	1	Adapter, 3/8" T. x 3/4"-16, O-Ring
119	11V35	1	Elbow, 90° - 1" T. x 1-5/8"-12, O-Ring
121	14T34	1	Elbow, 90° - 1" T. Swivel
122	10D99	2	Gushing, Reducer - 1-1/4" N.P.T.F. x 1" N.P.T.F.
124	23K04	2	Elbow, 90° - 1" N.P.T.F. x 1" T.
126	23R14	1	Tee, 1" T. Swivel
127	23A06	1	Adapter, 1/4" N.P.T. x 3/8" T.
128	14P91	1	Reducer, Tube End - 1" T. To 1/2" T.
129	11V33	1	Connector, 1" T. x 1-5/8"-12 O-Ring
130	14T34	1	Elbow, 90° - 1" T. Swivel
131	26J12	1	End, Reducer Tube - 1/2" T. x 3/8" T.
132	23F70	1	Nut, 1/2" Tube
133	12T24	1	Cap, 3/8" T.
137	V-80-481W	1	Hose Assembly - 1/2" I.D. x 75"

REF.	PART NUMBER	QTY.	DESCRIPTION
138	AJ-80-484W	1	Hose Assembly - 1/4" I.D. x 24"
139	AZ-80-484W	1	Hose Assembly - 1/4" I.D. x 57"
140	ER-80-484W	1	Hose Assembly - 1/4" I.D. x 134"
141	BB-80-491W	1	Hose Assembly - 3/8" I.D. x 80"
142	BS-80-491W	1	Hose Assembly - 3/8" I.D. x 64"
143	DK-80-491W	1	Hose Assembly - 3/8" I.D. x 28"
144	AB-80-496W	3	Hose Assembly - 3/8" I.D. x 56"
145	AC-80-496W	1	Hose Assembly - 3/8" I.D. x 90"
146	AD-80-496W	1	Hose Assembly - 3/8" I.D. x 134"
147	X-80-499W	1	Hose Assembly - 1/2" I.D. x 28"
148	T-80-501W	2	Hose Assembly - 1/2" I.D. x 28"
149	H-80-512W	1	Hose Assembly - 1" I.D. x 41"
150	J-80-510W	1	Hose Assembly - 1" I.D. x 33"
153	13E68	2	Switch, Toggle (1 Pole)
154	20Z53	3	Switch, Toggle (4 Pole)
157	EA-876-5289W	6	Wire, Jumper (#68A)
158	EC-876-5289W	1	Wire, Ground
159	AA-876-5489W	1	Harness, Wiring (Front Wheel Drive)
160	EB-876-5289W	1	Wire Assembly (#68E)
161	ED-876-5289W	1	Wire, Ground
	B-46-2289	2	Nameplate
	C-46-2289	1	Nameplate
166	15M25	1	Light (Socket & Lens) (Amber)
167	10F89	1	Bulb
169	11P92	4	Terminal, Ring - #6, 14 Ga. Wire

a - Consult Barber-Greene Repair Parts Department for repairs on this item.

FRONT WHEEL DRIVE PACKAGE
(Bogie Wheel Steering Assembly)
(Illustration 1 of 3)
CI-876-5435B

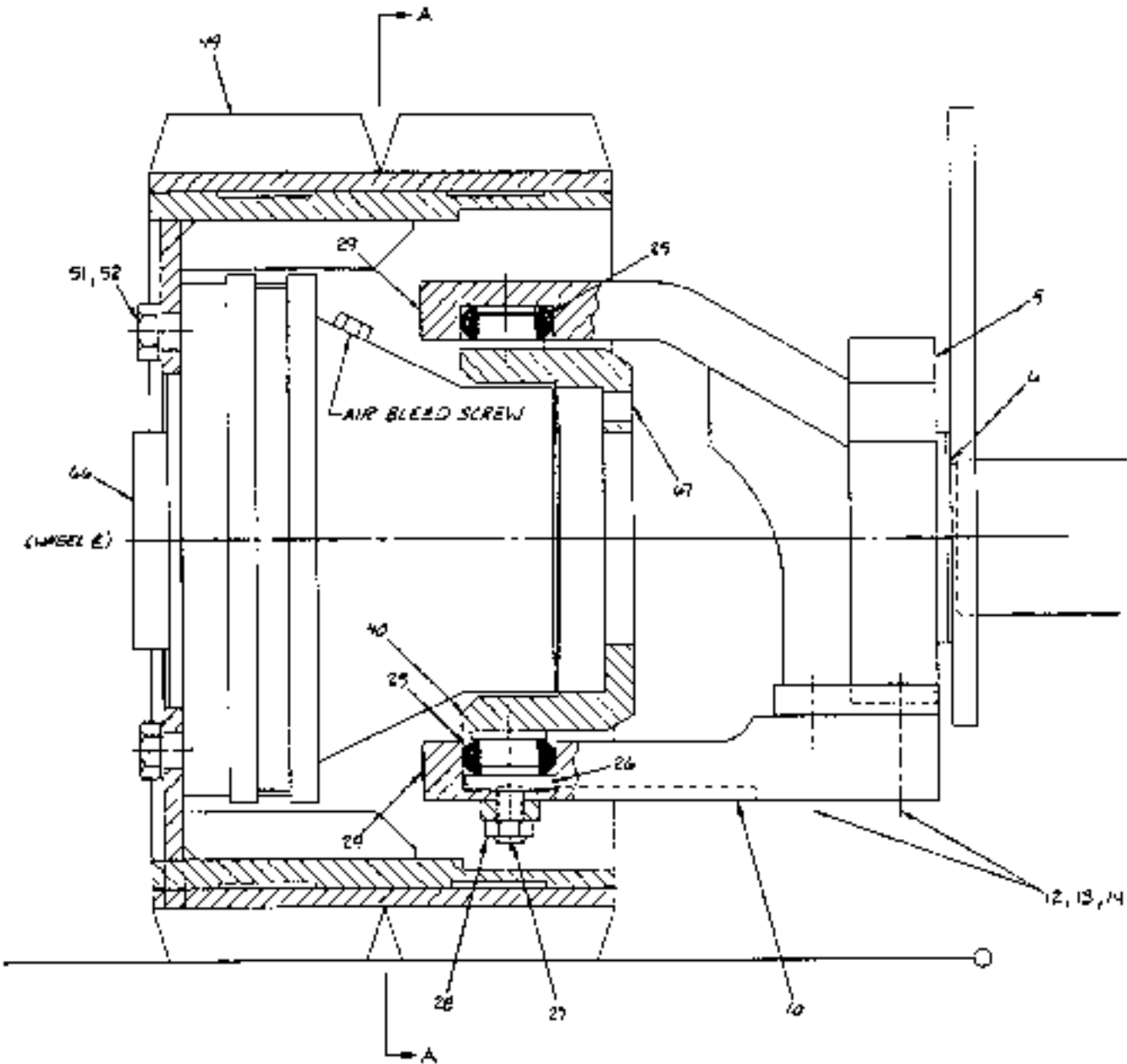

SECTIONAL VIEW (LEFT SIDE - REAR BOGIE WHEEL)

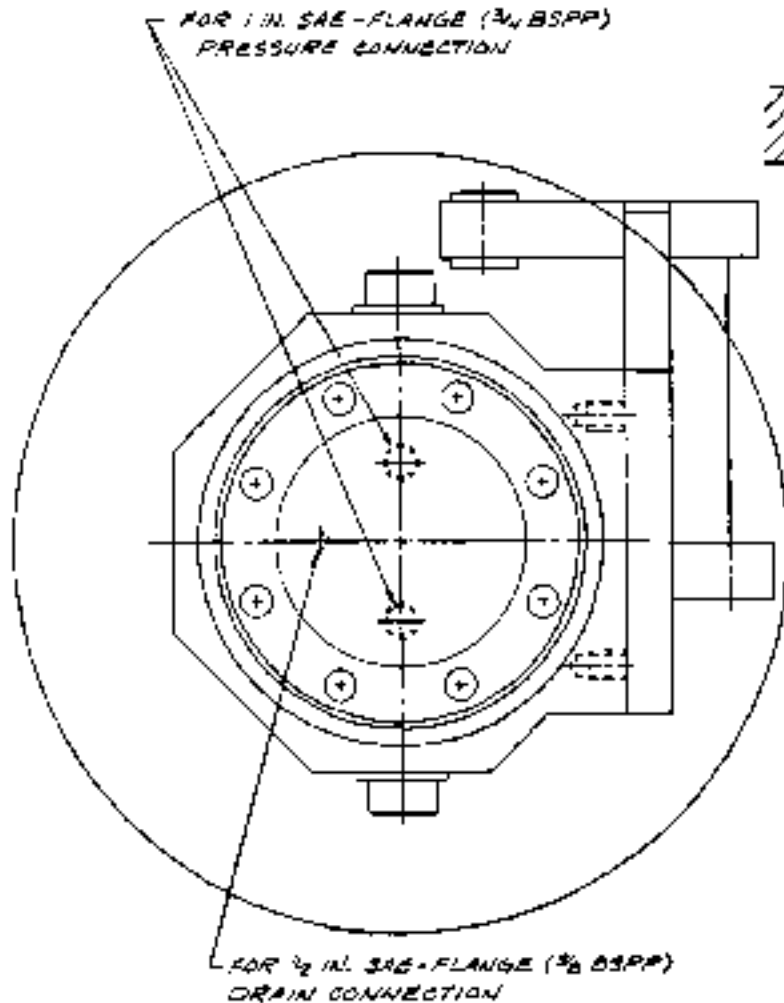

VIEW A-A

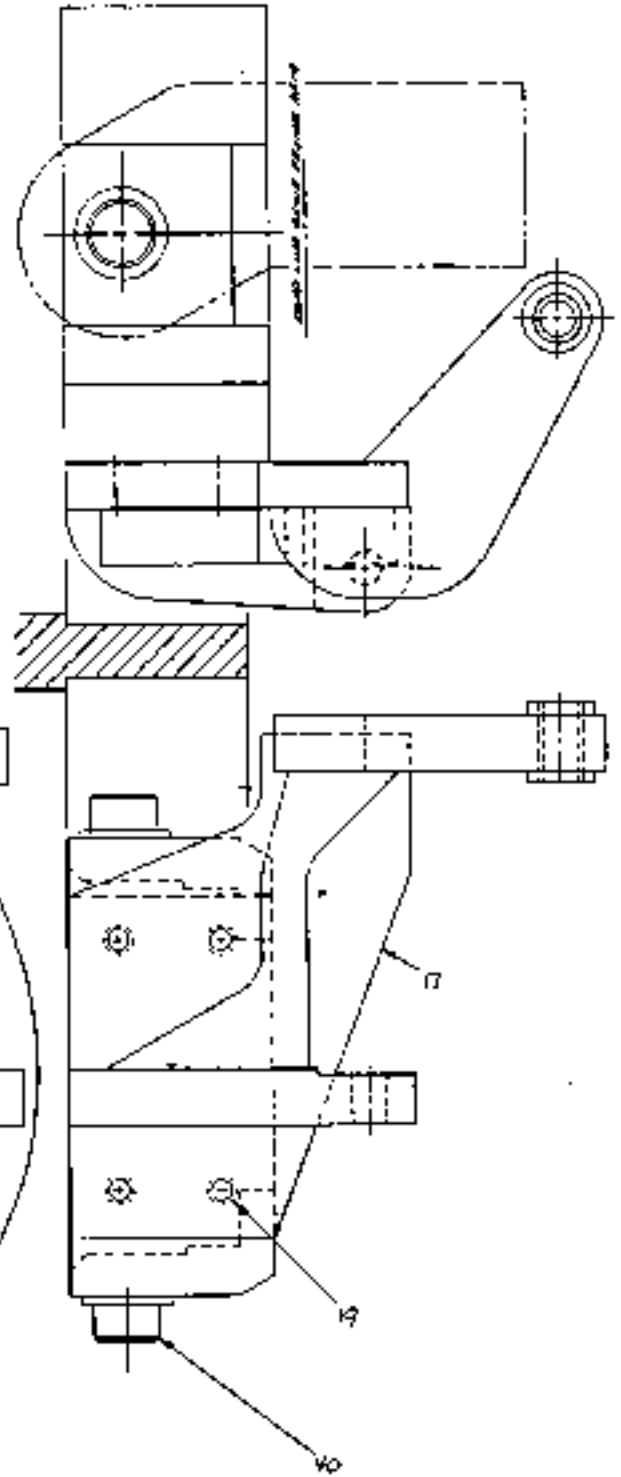

FRONT WHEEL DRIVE PACKAGE
(Hydraulic Piping Assembly)
(Illustration 2 of 3)
C1-876-5435B

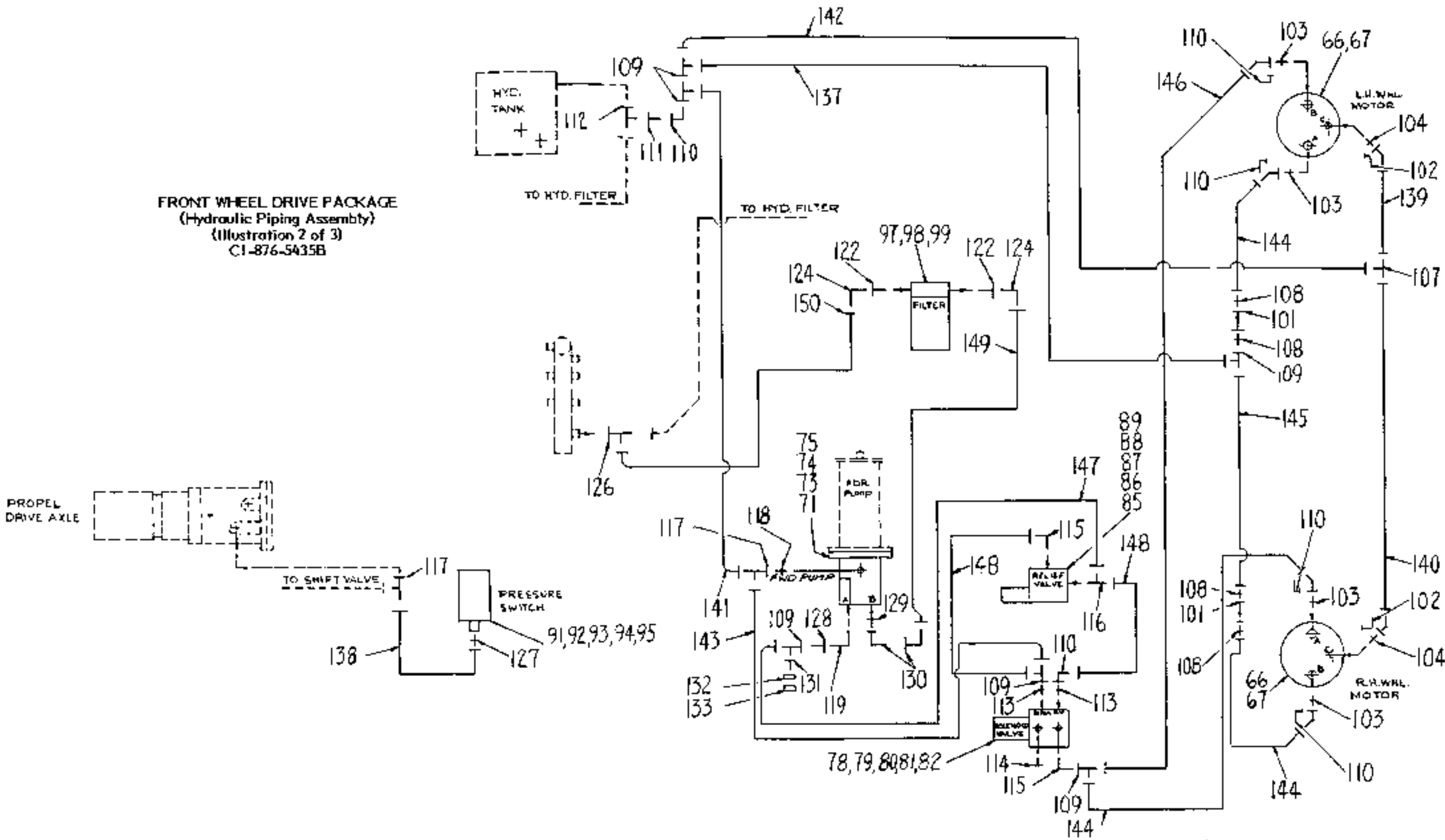

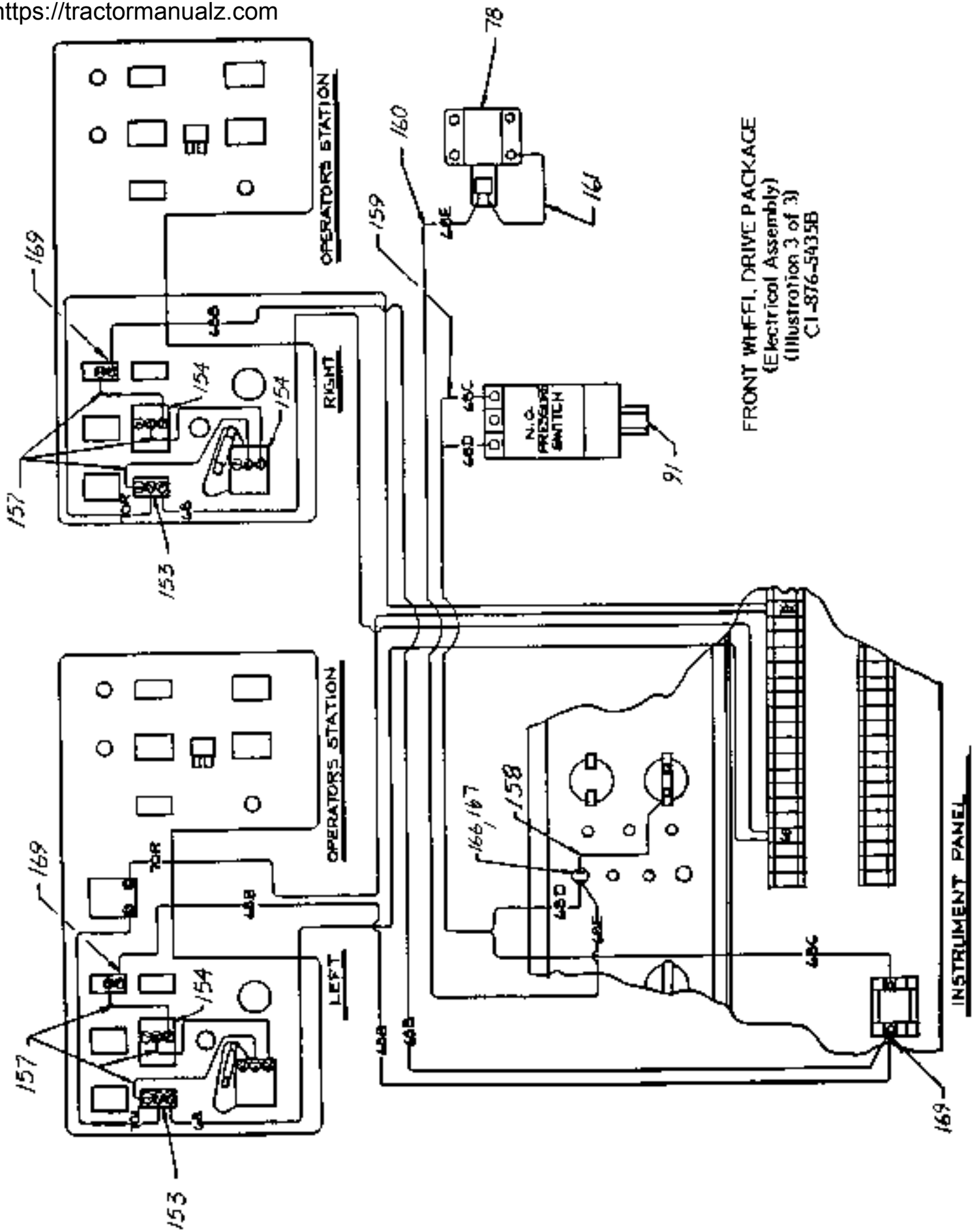

FRONT WHEEL DRIVE PACKAGE
(Electrical Assembly)
(Illustration 3 of 3)
CI-876-5435B

FRONT WHEEL DRIVE PACKAGE
(Bogie Wheel Steering, Hydraulic Piping & Electrical Components)

CI-876-5435B

(Before Ordering, Consult Table of Contents to Verify Proper Bill of Material Number.)

REF.	PART NUMBER	QTY.	DESCRIPTION
Ref. #4 thru #169 Symbolized by NONE on Illustrations 1, 2 & 3.			
4	XA-876-5437W	1	Frame, Bogie (Right Side)
5	YA-876-5437W	1	Frame, Bogie (Left Side)
6	DY-17-478	2	Washer, 3.78" I.D. x .12" Thick
10	ZB-876-5437WL	1	Bracket, Lower Arm (Left Side)
11	ZB-876-5437WR	1	Bracket, Lower Arm (Right Side)
12	16F51	8	3/4" x 4.00" Hex Head Cap Screw
13	26B48	9	3/4" Hardened Washer
14	29K73	4	Bushing, Tension - 2.75"
17	ZA-876-5437WL	1	Arm, Steering (Left Side)
18	ZA-876-5437WR	1	Arm, Steering (Right Side)
19	11L72	8	5/8" x 1.75" Ferry Head Cap Screw
25	28W64	4	Thrust Bushing Assembly - 1.5" Diameter
26	RE-876-5438	2	Plate, Bearing Adjusting
27	12S69	2	3/4" x 1.50" Socket Head Set Screw
28	27D25	2	3/4" Jam Nut
29	23C66	4	Fitting, 90° - 1/8" Lube
40	YA-876-5438	2	Yoke
47	A-46-2299	1	Decal *CAUTION - TO PREVENT UNEXPECTED MACHINE MOVEMENT PLACE F.W.D. SWITCH IN *OFF* POSITION BEFORE LEAVING OPERATORS AREA OR SERVICING MACHINE*
49	WC-876-5437W	2	Wheel & Tire Assembly (22" Diameter x 12" Wide)
51	28W62	16	M20 x 1.5" x 35 Class 12.9 Hex Head Cap Screw
52	28W71	16	M20 Hardened Washer
	WB-876-5438	1	Support, Valve
	WE-876-5438	1	Support, Switch
66 a	28W74	2	Motor, Hydraulic (Wheel)
67	29K61	16	M16 x 2.0MM x 4MM Class 12.9 Socket Head Cap Screw
71 a	20V80	1	Pump, Hydraulic - Variable Displacement - Pressure Compensating
73	26C57	2	1/2" x 2.75" Hex Head Cap Screw
74	C-17-478	2	Washer, 1/2" x .25"
75	27LB1	2	1/2" Lock Washer
	27C95	2	1/2" Hex Nut
	A-53-2517	1	Gasket
78 a	28W75	1	Valve, Solenoid - 4 Way
79	26C69	4	1/4" x 1" Hex Head Cap Screw
80	27L76	4	1/4" Lock Washer
81	27C86	4	1/4" Hex Nut
82	27L52	4	1/4" Washer
85 a	28W69	1	Valve, Hydraulic Relief (3500 PSI)

5/1/90 (1.1-5) (1.2-2)

(Continued)

REF.	PART NUMBER	QTY.	DESCRIPTION
86	27L76	2	1/4" Lock Washer
87	27C86	2	1/4" Hex Nut
88	27L52	2	1/4" Washer
89	16W90	2	1/4" x 2" Hex Head Cap Screw
91	28W67	1	Switch, Pressure
92	27K01	2	#10-24 x 1" Round Head Machine Screw
93	27L71	2	#10 Washer
94	27L99	2	#10 Lock Washer
95	27C79	2	#10-24 Nut
97	16W35	1	Filter, Hydraulic (Consisting in part of the following indented item):
	16X52	1	• Element, Filter
98	26E25	4	5/16" x .75" Hex Head Cap Screw
99	27L77	4	5/16" Lock Washer
101	28W70	2	Valve, Check
102	26J03	2	Elbow, 90° - Swivel x 3/8" T.
103	28W72	4	Adapter, 3/4" BSPP x 1/2" T.
104	28W68	2	Adapter, 3/8" BSPP x 3/8" T.
107	12X40	1	Tee, 3/8" T.
108	23L74	4	Adapter, 1/2" N.P.T.F. x 1/2" T.
109	13J69	6	Tee, 1/2" T. Swivel
110	15B83	6	Elbow, 90° - 1/2" T. Swivel
111	14P90	1	Reducer, Tube End - 1-1/4" T. To 1/2" T.
112	14T60	1	Tee, 1-1/4" T. Swivel
113	23H54	2	Adapter, 1/2" T. x 3/4"-16, O-Ring
114	23H55	1	Plug, 3/4"-16, O-Ring
115	23P99	2	Elbow, 90° - 1/2" T. x 3/4"-16, O-Ring
116	23R60	1	Tee, 1/2" T. x 3/4"-16, O-Ring
117	23T03	2	Tee, 3/8" T. Swivel
118	23R04	1	Adapter, 3/8" T. x 3/4"-16, O-Ring
119	11V35	1	Elbow, 90° - 1" T. x 1-5/8"-12, O-Ring
122	10D99	2	Bushing, Reducer - 1-1/4" N.P.T.F. x 1" N.P.T.F.
124	23K04	2	Elbow, 90° - 1" N.P.T.F. x 1" T.
126	23R14	1	Tee, 1" T. Swivel
127	23A06	1	Adapter, 1/4" N.P.T. x 3/8" T.
128	14P91	1	Reducer, Tube End - 1" T. To 1/2" T.
129	11V33	1	Connector, 1" T. x 1-5/8"-12 O-Ring
130	14T34	2	Elbow, 90° - 1" T. Swivel
131	26J12	1	End, Reducer Tube - 1/2" T. x 3/8" T.
132	23F70	1	Nut, 1/2" Tube
133	12T24	1	Cap, 3/8" T.
137	V-80-491W	1	Hose Assembly - 1/2" I.D. x 75"
138	AJ-80-484W	1	Hose Assembly - 1/4" I.D. x 24"
139	AZ-80-484W	1	Hose Assembly - 1/4" I.D. x 57"
140	ER-80-484W	1	Hose Assembly - 1/4" I.D. x 134"
141	BB-80-491W	1	Hose Assembly - 3/8" I.D. x 80"
142	DS-80-491W	1	Hose Assembly - 3/8" I.D. x 64"
143	DK-80-491W	1	Hose Assembly - 3/8" I.D. x 28"
144	AB-80-496W	3	Hose Assembly - 3/8" I.D. x 56"
145	AC-80-496W	1	Hose Assembly - 3/8" I.D. x 80"

5/1/90 (1.1-5) (1.2-2)

(Continued)

REF.	PART NUMBER	QTY.	DESCRIPTION
146	AD-80-496W	1	Hose Assembly - 3/8" I.D. x 134"
147	X-80-499W	1	Hose Assembly - 1/2" I.D. x 28"
148	T-80-501W	2	Hose Assembly - 1/2" I.D. x 28"
149	H-80-512W	1	Hose Assembly - 1" I.D. x 41"
150	J-80-510W	1	Hose Assembly - 1" I.D. x 33"
153	13E68	2	Switch, Toggle (1 Pole)
154	20Z53	3	Switch, Toggle (4 Pole)
157	EA-876-5289W	6	Wire, Jumper (#68A)
158	EC-876-5289W	1	Wire, Ground
159	AA-876-5489W	1	Harness, Wiring (Front Wheel Drive)
160	EB-876-5289W	1	Wire Assembly (#68E)
161	ED-876-5289W	1	Wire, Ground
	B-46-2289	2	Nameplate
	C-46-2289	1	Nameplate
166	15M25	1	Light (Socket & Lens) (Amber)
167	10F89	1	Bulb
169	11P92	4	Terminal, Ring - #6, 14 Ga. Wire

a - Consult Barber-Greene Repair Parts Department for repairs on this item.

FRONT WHEEL DRIVE PACKAGE
(Bogie Wheel Steering Assembly)
(Illustration 1 of 3)
C2-876-5435B

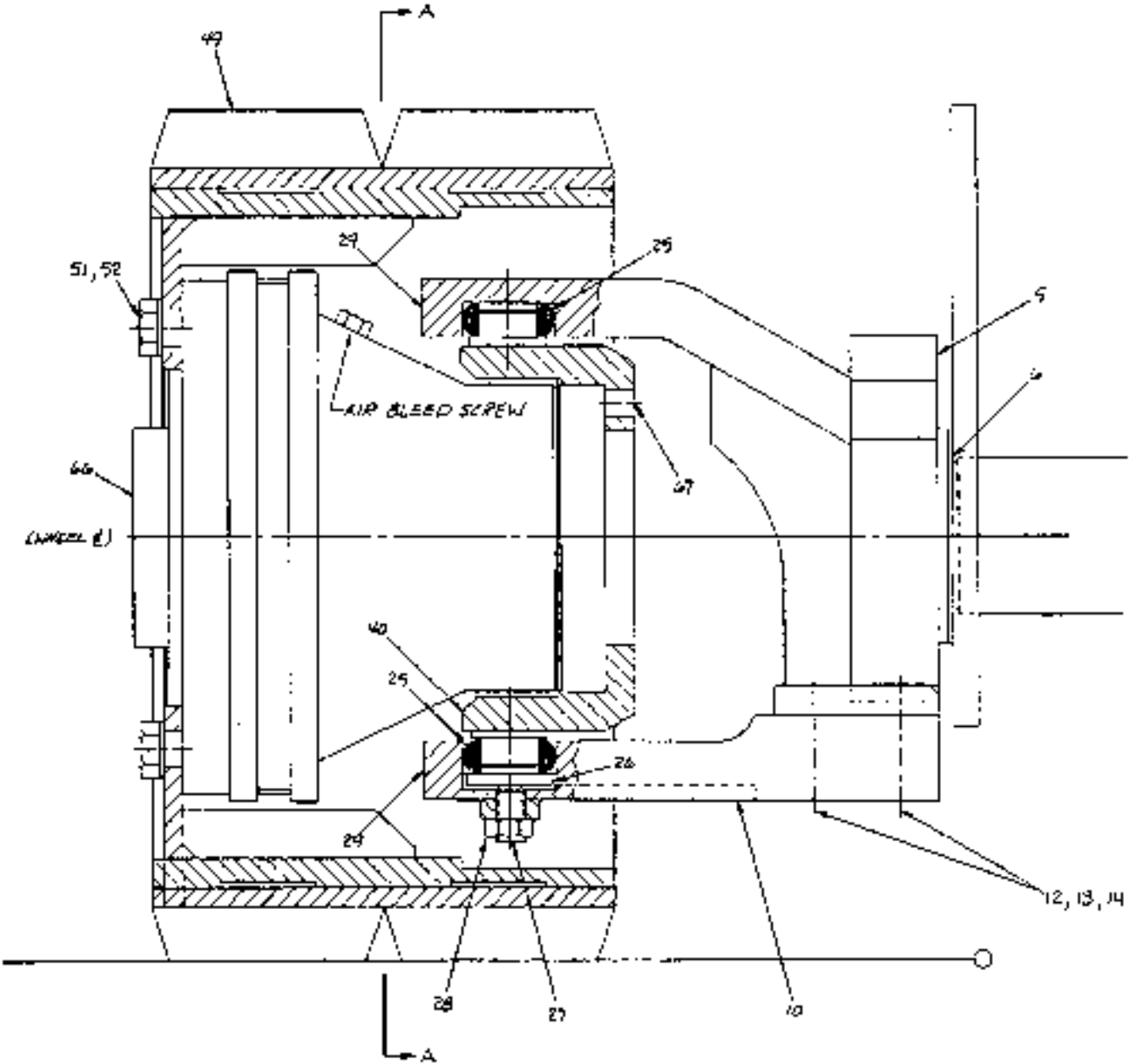

SECTIONAL VIEW (LEFT SIDE - REAR BOGIE WHEEL)

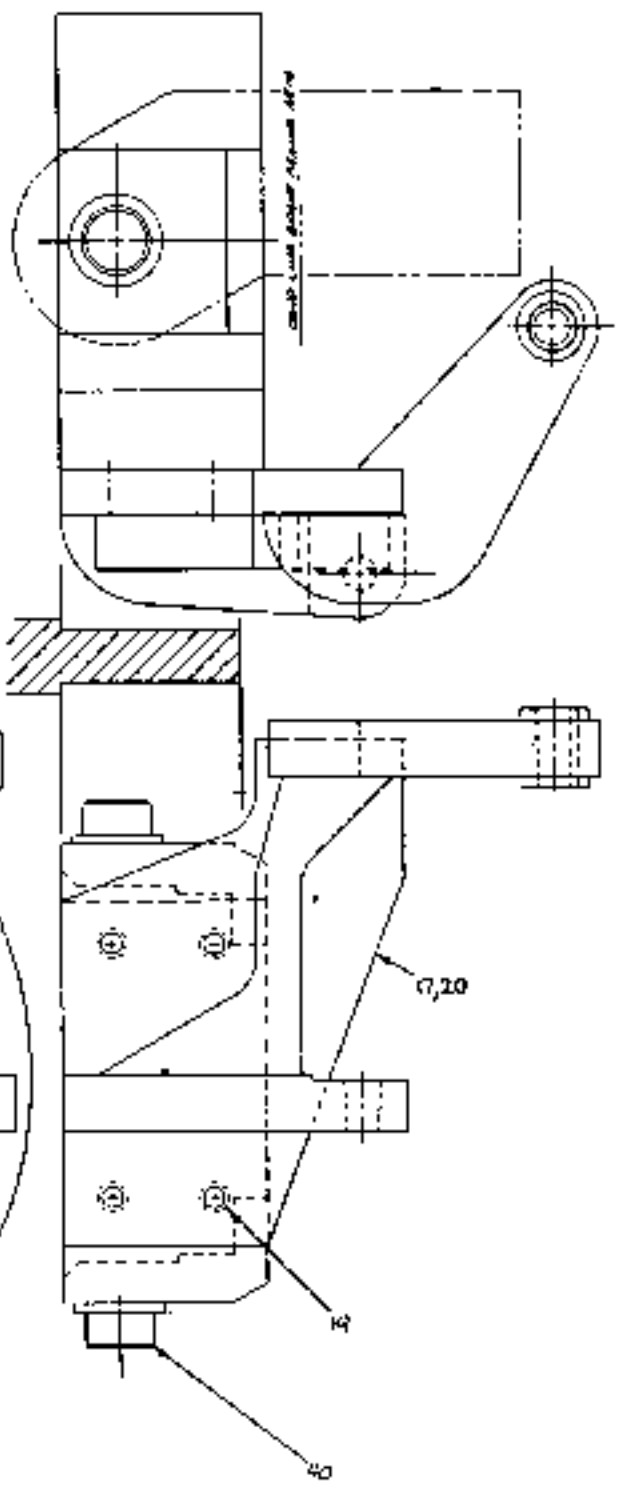
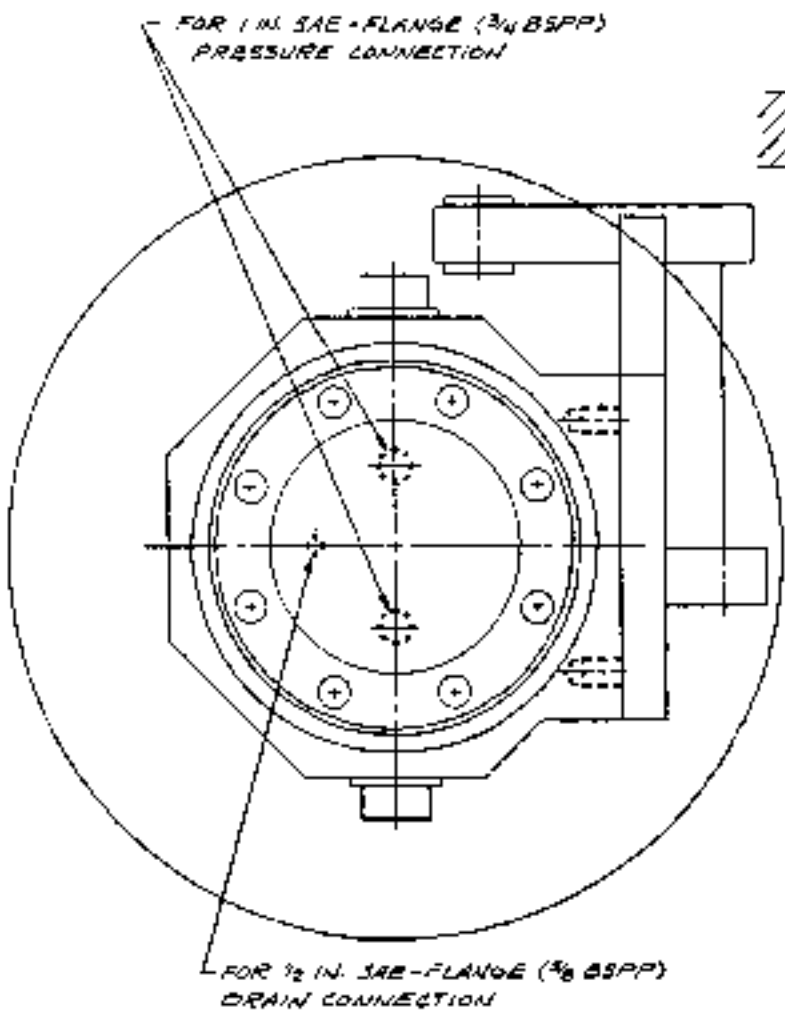

VIEW A-A

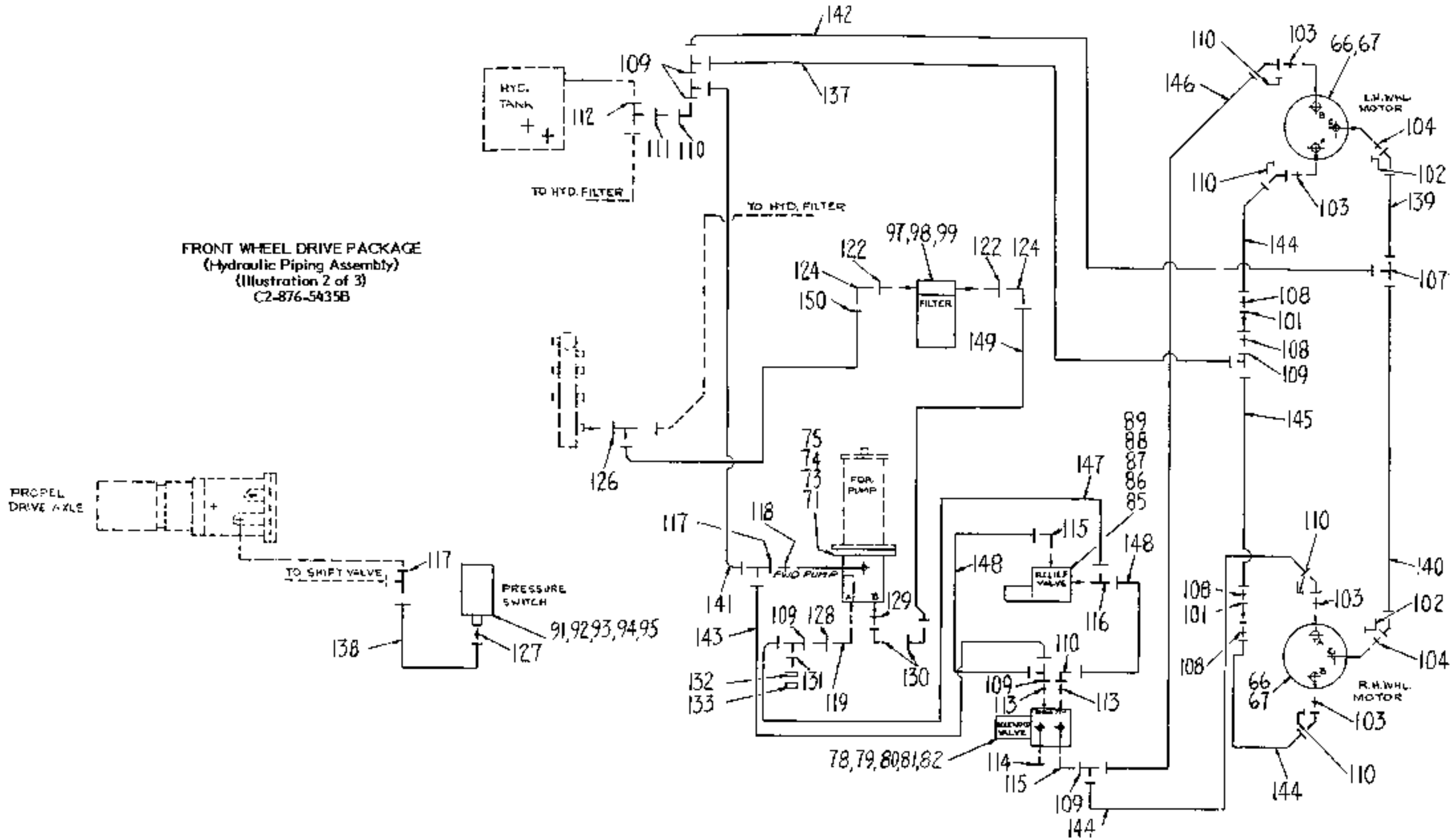

FRONT WHEEL DRIVE PACKAGE
 (Hydraulic Piping Assembly)
 (Illustration 2 of 3)
 C2-876-5435B

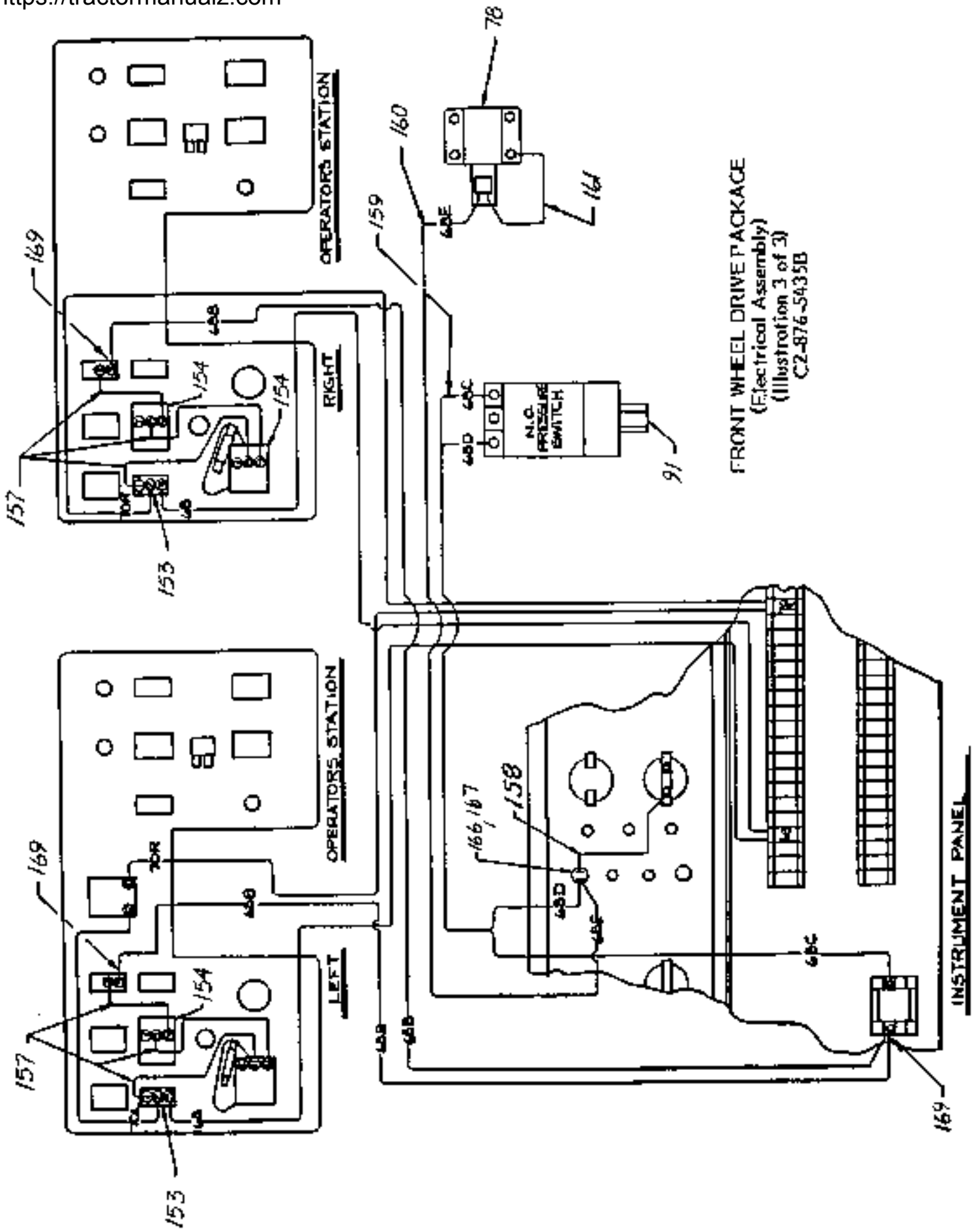

FRONT WHEEL DRIVE PACKAGE
(Electrical Assembly)
(Illustration 3 of 3)
C2-876-5A35B

FRONT WHEEL DRIVE PACKAGE
(Bogie Wheel Steering, Hydraulic Piping & Electrical Components)

CZ-876-5435B

(Before Ordering, Consult Table of Contents to Verify Proper Bill of Material Number.)

REF.	PART NUMBER	QTY.	DESCRIPTION
Ref. #4 thru #169 Symbolized by NONE on Illustrations 1, 2 & 3.			
4	XAI-876-5437W	1	Frame, Bogie (Right Side)
5	YAI-876-5437W	1	Frame, Bogie (Left Side)
6	DY-17-47B	2	Washer, 3.78" I.D. x .12" Thick
10	ZB-876-5437WL	1	Bracket, Lower Arm (Left Side)
11	ZB-876-5437WR	1	Bracket, Lower Arm (Right Side)
12	16F51	8	3/4" x 4.00" Hex Head Cap Screw
13	26B48	8	3/4" Hardened Washer
14	29K73	4	Bushing, Tension - 2.75"
17	CA-876-5439WL	1	Arm, Steering (Left Side)
18	CA-876-5439WR	1	Arm, Steering (Right Side)
19	11L72	8	5/8" x 1.75" Ferry Head Cap Screw
20	29M34	2	Bushing, 3/4" I.D. x 1.75"
25	28W64	4	Thrust Bushing Assembly - 1.5" Diameter
26	RE-876-5438	2	Plate, Bearing Adjusting
27	12S69	2	3/4" x 1.50" Socket Head Set Screw
28	27D25	2	3/4" Jam Nut
29	23C66	4	Fitting, 90° - 1/8" Lube
40	YA-876-5438	2	Yoke
47	A-46-2299	1	Decal "CAUTION - TO PREVENT UNEXPECTED MACHINE MOVEMENT PLACE F.W.D. SWITCH IN "OFF" POSITION BEFORE LEAVING OPERATORS AREA OR SERVICING MACHINE"
49	WC-876-5437W	2	Wheel & Tire Assembly (22" Diameter x 12" Wide)
51	28W62	16	M20 x 1.5" x 35 Class 12.9 Hex Head Cap Screw
52	28W71	16	M20 Hardened Washer
	WB-876-5438	1	Support, Valve
	WE-876-5438	1	Support, Switch
66 a	28W74	2	Motor, Hydraulic (Wheel)
67	29K61	16	M16 x 2.0MM x 4MM Class 12.9 Socket Head Cap Screw
71 a	20V80	1	Pump, Hydraulic - Variable Displacement - Pressure Compensating
73	26C57	2	1/2" x 2.75" Hex Head Cap Screw
74	C-17-47B	2	Washer, 1/2" x .25"
75	27L81	2	1/2" Lock Washer
	27C95	2	1/2" Hex Nut
	A-53-2517	1	Gasket
78 a	28W75	1	Valve, Solenoid - 4 Way
79	26C69	4	1/4" x 1" Hex Head Cap Screw
80	27L76	4	1/4" Lock Washer
81	27C86	4	1/4" Hex Nut
82	27L52	4	1/4" Washer

REF.	PART NUMBER	QTY.	DESCRIPTION
85 a	28W69	1	Valve, Hydraulic Relief (3500 PSI)
86	27L76	2	1/4" Lock Washer
87	27C86	2	1/4" Hex Nut
88	27L52	2	1/4" Washer
89	16W90	2	1/4" x 2" Hex Head Cap Screw
91	28W67	1	Switch, Pressure
92	27K01	2	#10-24 x 1" Round Head Machine Screw
93	27L71	2	#10 Washer
94	27L99	2	#10 Lock Washer
95	27C79	2	#10-24 Nut
97	16W35	1	Filter, Hydraulic (Consisting in part of the following indented item):
	16X52	1	• Element, Filter
98	26E25	4	5/16" x .75" Hex Head Cap Screw
99	27L77	4	5/16" Lock Washer
101	28W70	2	Valve, Check
102	26J03	2	Elbow, 90° - Swivel x 3/8" T.
103	28W72	4	Adapter, 3/4" BSPP x 1/2" T.
104	28W68	2	Adapter, 3/8" BSPP x 3/8" T.
107	12X40	1	Tee, 3/8" T.
108	23L74	4	Adapter, 1/2" N.P.T.F. x 1/2" T.
109	13J69	6	Tee, 1/2" T. Swivel
110	15B83	6	Elbow, 90° - 1/2" T. Swivel
111	14P90	1	Reducer, Tube End - 1-1/4" T. To 1/2" T.
112	14T60	1	Tee, 1-1/4" T. Swivel
113	23H54	2	Adapter, 1/2" T. x 3/4"-16, O-Ring
114	23H55	1	Plug, 3/4"-16, O-Ring
115	23P99	2	Elbow, 90° - 1/2" T. x 3/4"-16, O-Ring
116	23R60	1	Tee, 1/2" T. x 3/4"-16, O-Ring
117	23T03	2	Tee, 3/8" T. Swivel
118	23R04	1	Adapter, 3/8" T. x 3/4"-16, O-Ring
119	11V35	1	Elbow, 90° - 1" T. x 1-5/8"-12, O-Ring
122	10D99	2	Bushing, Reducer - 1-1/4" N.P.T.F. x 1" N.P.T.F.
124	23K04	2	Elbow, 90° - 1" N.P.T.F. x 1" T.
126	23R14	1	Tee, 1" T. Swivel
127	23A06	1	Adapter, 1/4" N.P.T. x 3/8" T.
128	14P91	1	Reducer, Tube End - 1" T. To 1/2" T.
129	11V33	1	Connector, 1" T. x 1-5/8"-12 O-Ring
130	14T34	2	Elbow, 90° - 1" T. Swivel
131	26J12	1	End, Reducer Tube - 1/2" T. x 3/8" T.
132	23T70	1	Nut, 1/2" Tube
133	12T24	1	Cap, 3/8" T.
137	V-80-481W	1	Hose Assembly - 1/2" I.D. x 75"
138	AJ-80-484W	1	Hose Assembly - 1/4" I.D. x 24"
139	AZ-80-484W	1	Hose Assembly - 1/4" I.D. x 57"
140	ER-80-484W	1	Hose Assembly - 1/4" I.D. x 134"
141	BB-80-491W	1	Hose Assembly - 3/8" I.D. x 80"
142	B5-80-491W	1	Hose Assembly - 3/8" I.D. x 64"
143	DK-80-491W	1	Hose Assembly - 3/8" I.D. x 28"
144	AB-80-496W	3	Hose Assembly - 3/8" I.D. x 56"

REF.	PART NUMBER	QTY.	DESCRIPTION
145	AC-80-496W	1	Hose Assembly - 3/8" I.D. x 80"
146	AD-80-496W	1	Hose Assembly - 3/8" I.D. x 134"
147	X-80-499W	1	Hose Assembly - 1/2" I.D. x 28"
148	T-80-501W	2	Hose Assembly - 1/2" I.D. x 28"
149	II-80-512W	1	Hose Assembly - 1" I.D. x 41"
150	J-80-510W	1	Hose Assembly - 1" I.D. x 33"
153	13E68	2	Switch, Toggle (1 Pole)
154	20Z53	3	Switch, Toggle (4 Pole)
157	EA-876-5289W	6	Wire, Jumper (#68A)
158	EC-876-5289W	1	Wire, Ground
159	AA-876-5489W	1	Harness, Wiring (Front Wheel Drive)
160	EB-876-5289W	1	Wire Assembly (#68E)
161	ED-876-5289W	1	Wire, Ground
	B-46-2289	2	Nameplate
	C-46-2289	1	Nameplate
166	15M25	1	Light (Socket & Lens) (Amber)
167	19F89	1	Bulb
169	11P92	4	Terminal, Ring - #6, 14 Ga. Wire

a - Consult Barber-Greene Repair Parts Department for repairs on this item.

FRONT WHEEL DRIVE PACKAGE
(Bogie Wheel Steering Assembly)
(Illustration 1 of 2)
C3-876-5435B

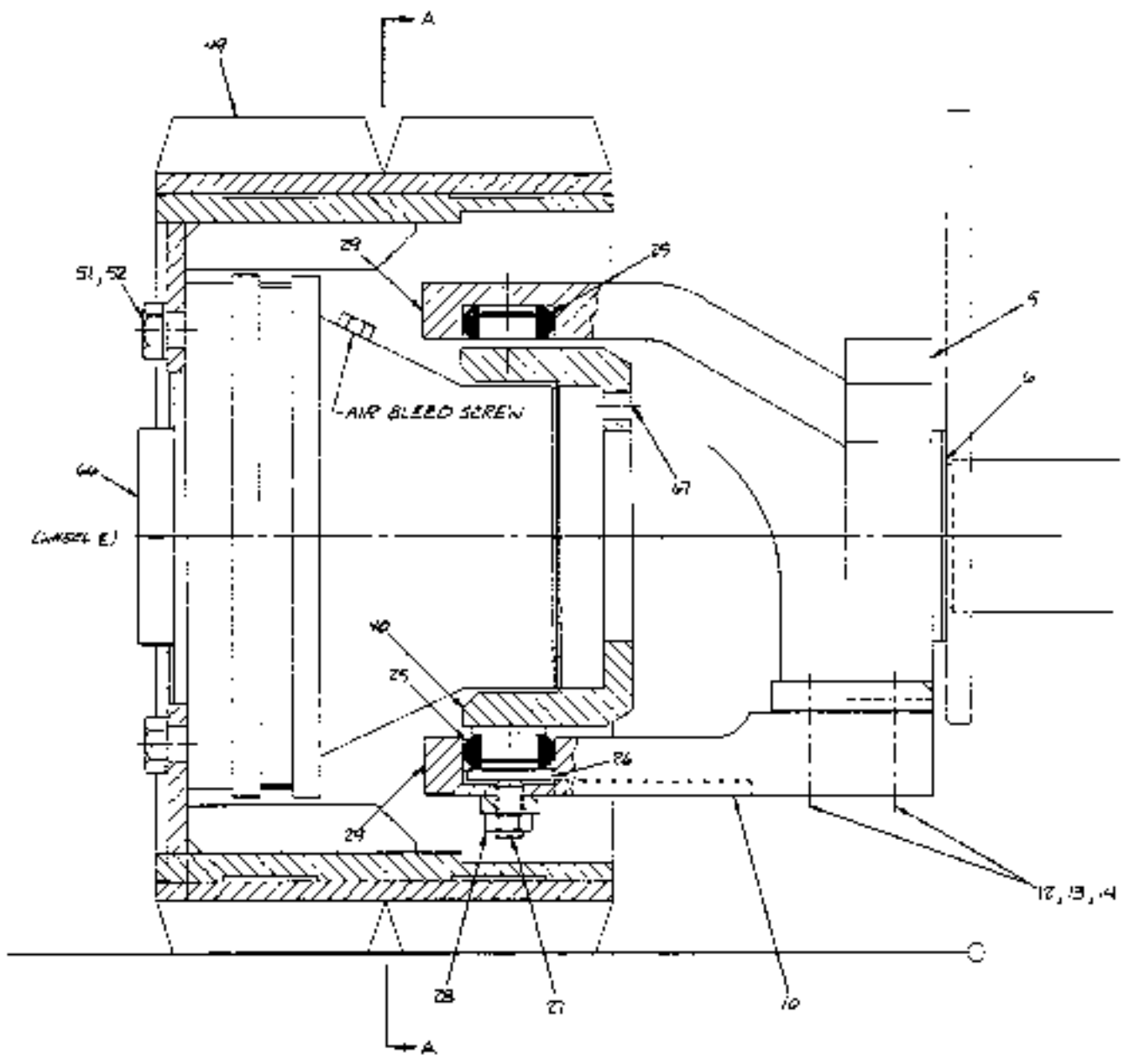

SECTIONAL VIEW (LEFT SIDE - REAR BOGIE WHEEL)

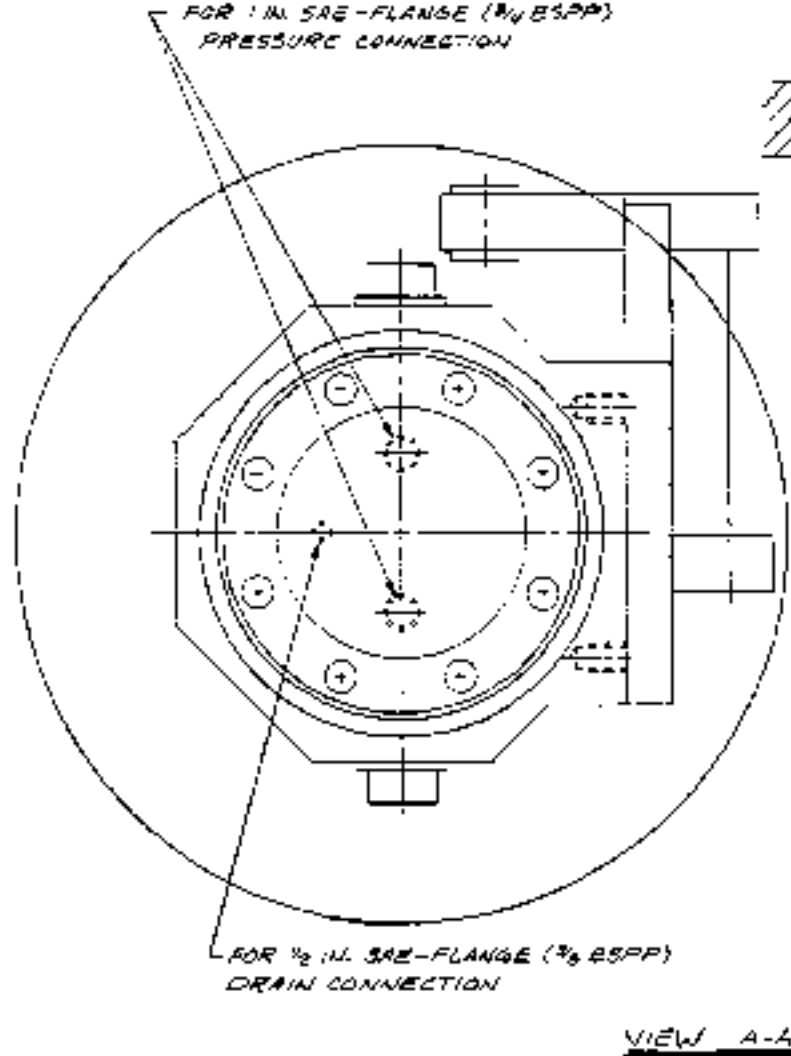

VIEW A-A

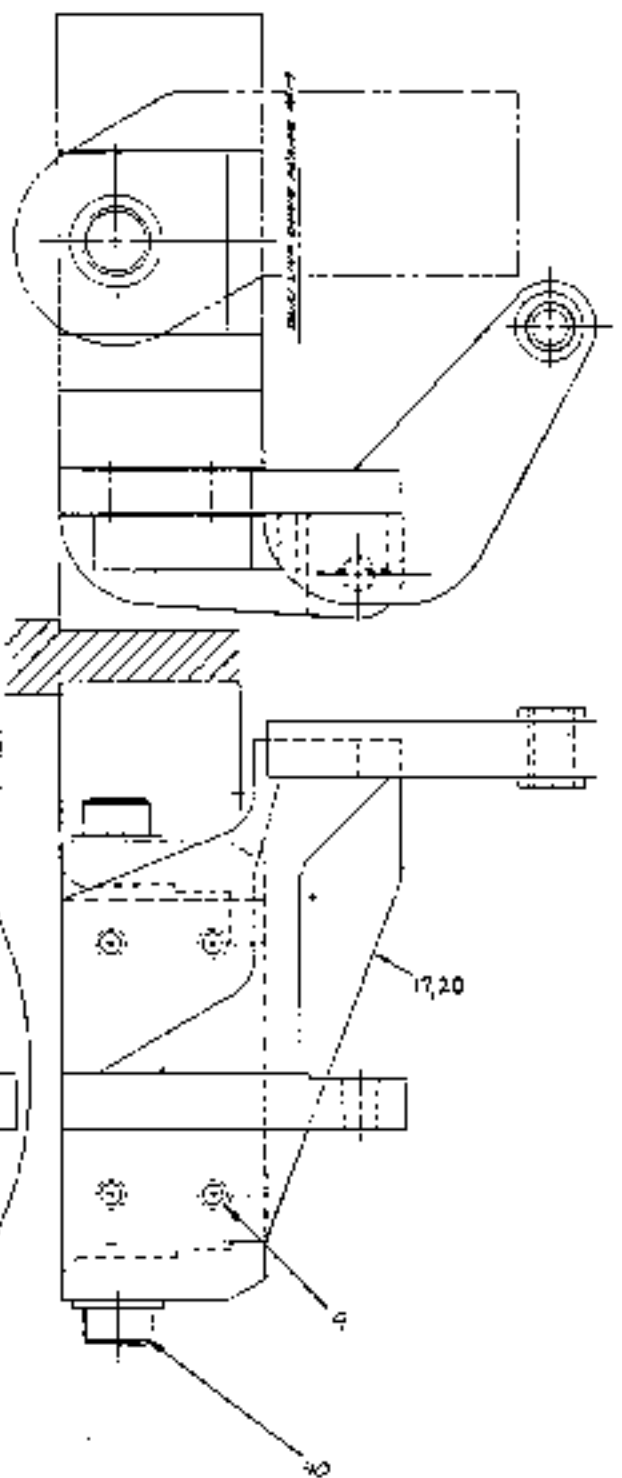

FRONT WHEEL DRIVE PACKAGE
(Hydraulic Piping Assembly)
(Illustration 2 of 2)
C3-876-5435B

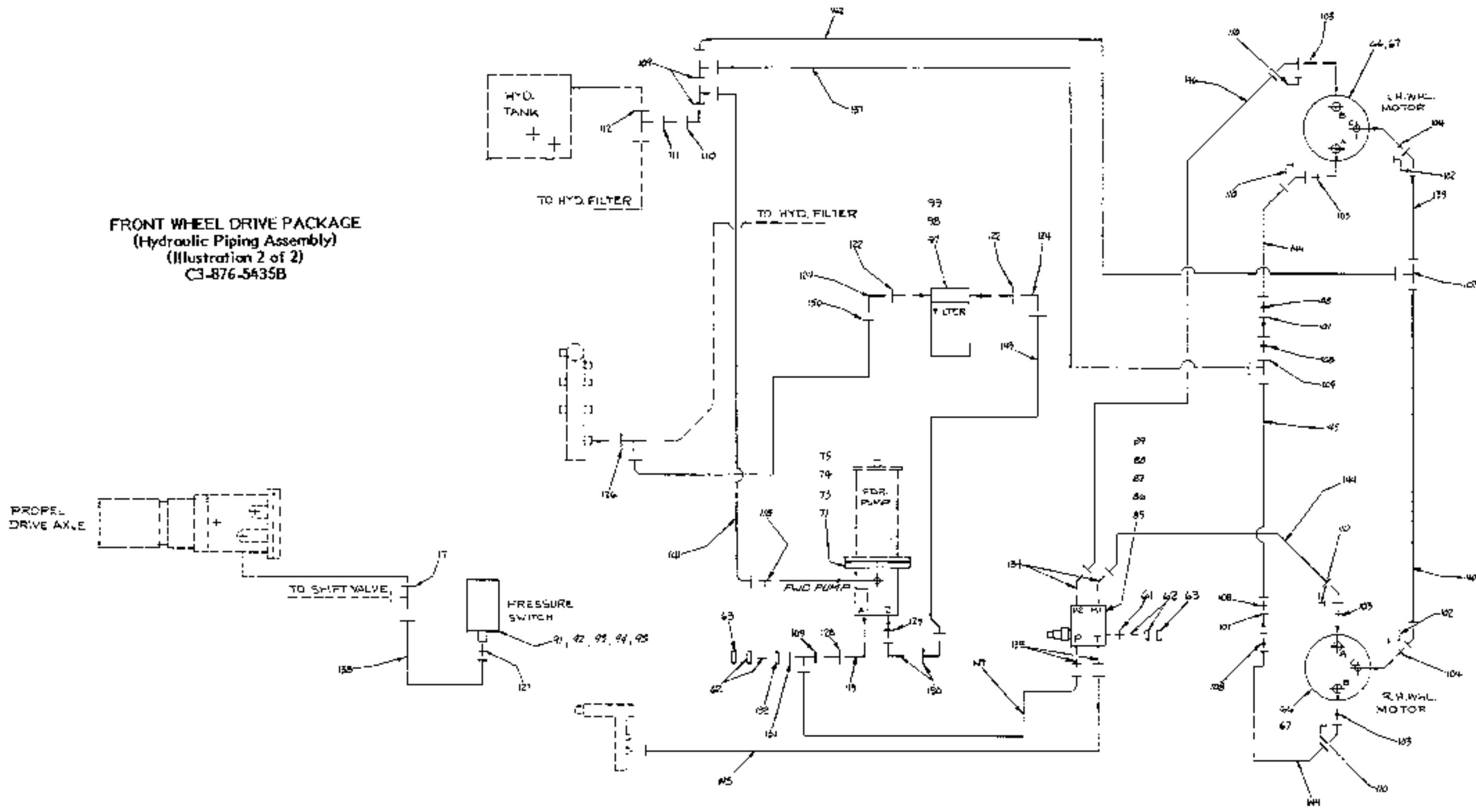

**FRONT WHEEL DRIVE PACKAGE
(Bogie Wheel Steering, Hydraulic Piping & Electrical Components)**

C3-876-5435B

(Before Ordering, Consult Table of Contents to Verify Proper Bill of Material Number.)

REF.	PART NUMBER	QTY.	DESCRIPTION
Ref. #5 thru #150 Symbolized by NONE on Illustrations 1 & 2.			
	XAI-876-5437W	1	Frame, Bogie (Right Side)
5	YAI-876-5437W	1	Frame, Bogie (Left Side)
6	DY-17-478	2	Washer, 3.78" I.D. x .12" Thick
10	ZB-876-5437WL	1	Bracket, Lower Arm (Left Side)
	ZB-876-5437WR	1	Bracket, Lower Arm (Right Side)
12	16F51	8	3/4" x 4.00" Hex Head Cap Screw
13	26948	8	3/4" Hardened Washer
14	29K73	4	Bushing, Tension - 2.75"
17	CA-876-5439WL	1	Arm, Steering (Left Side)
	CA-876-5439WR	1	Arm, Steering (Right Side)
19	11L72	8	5/8" x 1.75" Ferry Head Cap Screw
20	29M34	2	Bushing, 3/4" I.D. x 1.75"
25	28W64	4	Thrust Bushing Assembly - 1.5" Diameter
	RE-876-5438	2	Plate, Bearing Adjusting
27	12569	2	3/4" x 1.50" Socket Head Set Screw
28	27D25	2	3/4" Jam Nut
29	23C66	4	Fitting, 90° - 1/8" Lube
40	YA-876-5438	2	Yoke
	A-46-2299	1	Decal "CAUTION - TO PREVENT UNEXPECTED MACHINE MOVEMENT PLACE F.W.D. SWITCH IN "OFF" POSITION BEFORE LEAVING OPERATORS AREA OR SERVICING MACHINE"
49	WC-876-5437W	2	Wheel & Tire Assembly (22" Diameter x 12" Wide)
51	28W62	16	M20 x 1.5" x 40MM Class 12.9 Hex Head Cap Screw
52	28W71	16	M20 Hardened Washer
	WBI-876-5438	1	Support, Valve
	WEI-876-5438	1	Support, Switch
61	23N81	1	Connector, 1/4" T. x 7/16"-20 Str. Thd.
62	29J32	2	Nipple, Tube End
63	29F42	2	Cap, Dust
66 a	28W74	2	Motor, Hydraulic (Wheel)
67	29K61	16	M16 x 2.0MM x 40MM Class 12.9 Socket Head Cap Screw
71 a	20V80	1	Pump, Hydraulic - Variable Displacement - Pressure Compensating
73	26C57	2	1/2" x 2.75" Hex Head Cap Screw
74	C-17-478	2	Washer, 1/2" x .25"
75	27L81	2	1/2" Lock Washer
	27C95	2	1/2" Hex Nut
	A-53-2517	1	Gasket
85 a	29N58	1	Valve, Hydraulic Relief (3500 PSI)
86	27L78	2	3/8" Lock Washer

5/1/90 (1.1-7) (1,2-3)

SECTION 2 PAGE 35

(Continued)

REF.	PART NUMBER	QTY.	DESCRIPTION
87	27C90	2	3/8" Hex Nut
88	27L56	2	3/8" Plain Washer
89	23X30	2	3/8" x 3" Hex Head Cap Screw
91	29P52	1	Switch, Pressure
92	20X05	2	1/4" x 2.25" Hex Head Machine Screw
93	27L52	2	1/4" Plain Washer
94	27L76	2	1/4" Lock Washer
95	27C86	2	1/4" Hex Nut
97	16W35	1	Filter, Hydraulic (Consisting in part of the following indented item):
	16X52	1	. Element, Filter
98	26E25	4	5/16" x .75" Hex Head Cap Screw
99	27L77	4	5/16" Lock Washer
101	28W70	2	Valve, Check
102	26J03	2	Elbow, 90° - Swivel x 3/8" T.
103	28W72	4	Connector, Reducer - 3/4" BSP x 1/2" T.
104	28W68	2	Connector, 3/8" BSP x 3/8" T.
107	12X40	1	Tee, 3/8" T.
108	23L74	4	Connector, 1/2" N.P.T.F. x 1/2" T.
109	13J69	4	Tee, 1/2" T. Swivel
110	15B83	5	Elbow, 90° - 1/2" T. Swivel
111	14P90	1	Reducer, Tube End - 1-1/4" T. x 1/2" T.
112	14T60	1	Tee, 1-1/4" T. Swivel
	23H54	2	Connector, 1/2" T. x 3/4"-16, O-Ring
117	23T03	2	Tee, 3/8" T. Swivel
118	23R04	1	Connector, 3/8" T. x 3/4"-16, O-Ring
119	11V35	1	Elbow, 90° - 1" T. x 1-5/8"-12, O-Ring
122	10D99	2	Bushing, Reducer - 1-1/4" N.P.T.F. x 1" N.P.T.F.
124	23K04	2	Elbow, 90° - 1" N.P.T.F. x 1" T.
126	23R14	1	Tee, 1" T. Swivel
127	23A06	1	Connector, 1/4" N.P.T. x 3/8" T.
128	14P91	1	Reducer, Tube End - 1" T. x 1/2" T.
129	11V33	1	Connector, 1" T. x 1-5/8"-12 O-Ring
130	14T34	2	Elbow, 90° - 1" T. Swivel
131	26J11	1	Reducer, Tube End - 1/2" T. x 1/4" T.
132	23F70	1	Nut, 1/2" Tube
134	23R54	2	Elbow, 45° - 1/2" T. x 3/4"-16 Str. Thd.
135	23H54	2	Connector, 1/2" T. x 3/4"-16 Str. Thd.
137	V-80-481W	1	Hose Assembly - 1/2" I.D. x 75"
138	AJ-80-484W	1	Hose Assembly - 1/4" I.D. x 24"
139	AZ-80-484W	1	Hose Assembly - 1/4" I.D. x 57"
140	ER-80-484W	1	Hose Assembly - 1/4" I.D. x 134"
141	BB-80-491W	1	Hose Assembly - 3/8" I.D. x 80"
142	BS-80-491W	1	Hose Assembly - 3/8" I.D. x 64"
143	DK-80-491W	1	Hose Assembly - 3/8" I.D. x 28"
144	AD-80-496W	3	Hose Assembly - 3/8" I.D. x 56"
145	AC-80-496W	1	Hose Assembly - 3/8" I.D. x 80"
146	AD-80-496W	1	Hose Assembly - 3/8" I.D. x 134"
147	X-80-499W	1	Hose Assembly - 1/2" I.D. x 28"
149	H-80-512W	1	Hose Assembly - 1" I.D. x 41"

REF.	PART NUMBER	QTY.	DESCRIPTION
150	J-80-510W	1	Hose Assembly - 1" I.D. x 33"
	13E68	2	Switch, Toggle (1 Pole)
	20253	3	Switch, Toggle (4 Pole)
	EA-876-5289W	6	Wire, Jumper (#68A)
	EC-876-5289W	1	Wire, Ground
	AA1-876-5489W	1	Harness, Wiring (Front Wheel Drive)
	EB-876-5289W	1	Wire Assembly (#68E)
	ED-876-5289W	1	Wire, Ground
	D-46-2289	2	Nameplate
	C-46-2289	1	Nameplate
	15M25	1	Light (Socket & Lens) (Amber)
	10F89	1	Bulb
	11P92	4	Terminal, Ring - #6, 14 Ga. Wire
	38Z59	2	Terminal, Ma. Slip-On, 18-22 Ga., .25" Tab
	23S25	1	Grommet
	23S50	1	Grip, Cord - 1/2"

a - Consult Barber-Greene Repair Parts Department for repairs on this item.

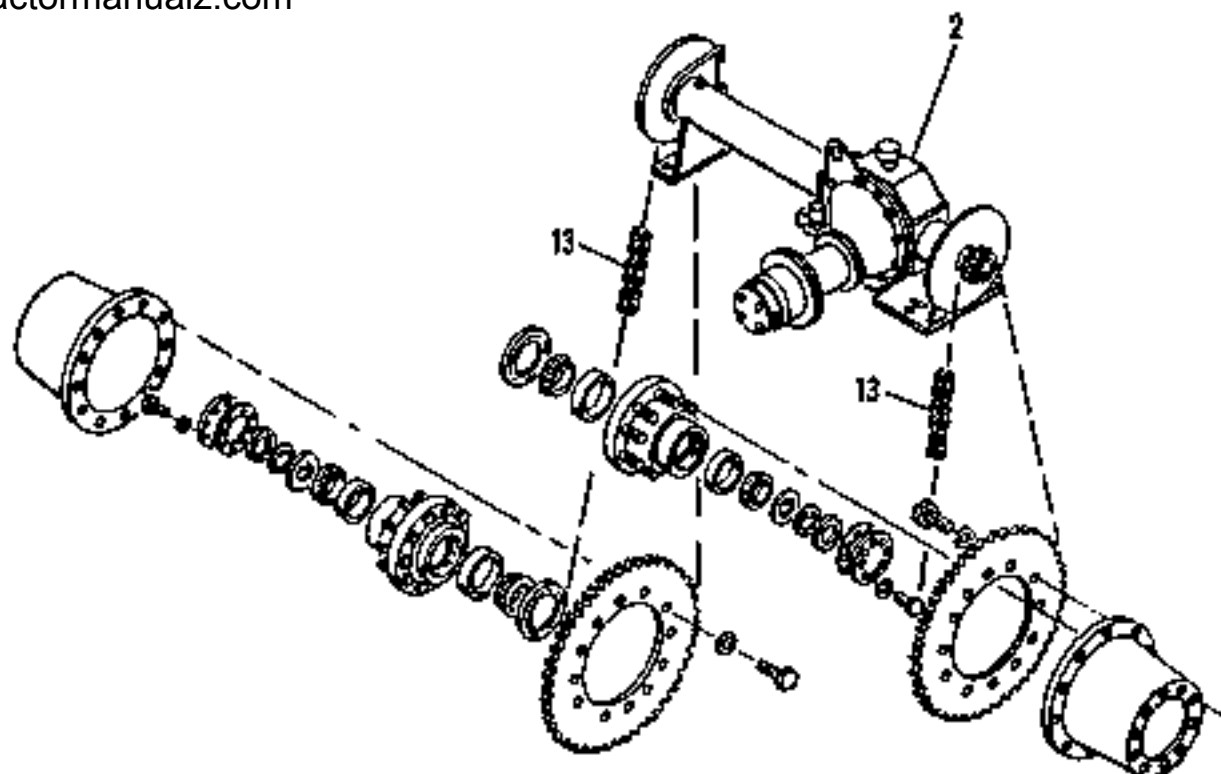

WHEEL DRIVE AXLE ASSEMBLY & SPROCKET

A-876-5430B

(Before Ordering, Consult Table of Contents to Verify Proper Bill of Material Number.)

REF.	PART NUMBER	QTY.	DESCRIPTION
2	A-53-2805A	1	Drive Axle Assembly (See Section 2 Page 40)

The following three items are used to shim between Axle Assembly & Main Frame.

CL-17-218	4	Shim, .25
CM-17-218	4	Shim, #10 Go.
CN-17-218	4	Shim, #16 Go.
CP-17-218	4	Shim, #20 Go.

The following hardware is used to hold Axle Assembly to Main Frame.

27Y79	8	3/4"-16 U.N.F. x 3-1/2" Hex Head Cap Screw
26B48	4	3/4" Washer (1 hardened)
27D24	4	3/4"-16 U.N.F. Jam Nut
13 27Y80	2	Drive Chain, #120 HE (72 Links)

The following three items make up the breather assembly for the Two Speed Planetary.

23M75	1	Coupling, Reducer - 1/4" P. x 1/2" P.
23B38	1	Reducer, Bell - 1/2" P. x 1/4" P.
B-17-122	1	Nipple, 1/2" P. x 1-1/2"

DRIVE AXLE ASSEMBLY
A-53-2805A

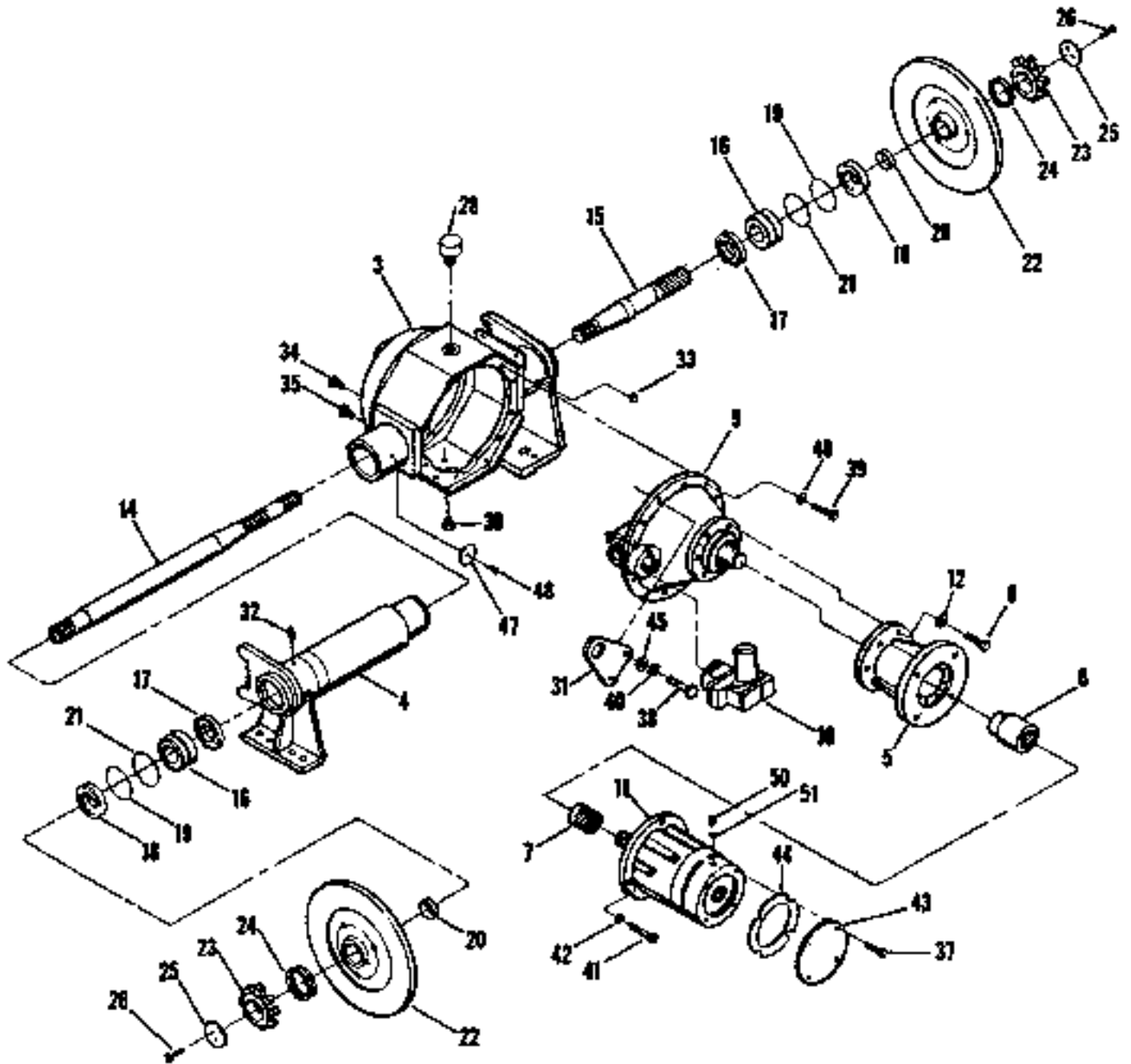

DRIVE AXLE ASSEMBLY

A-53-2805A

(From Section 2 Page 38)

(Before Ordering, Consult Table of Contents to Verify Proper Bill of Material Number.)

REF.	PART NUMBER	QTY.	DESCRIPTION
Ref. #3 thru #51 Symbolized by NONE on Illustration.			
3	BA-53-2807W	1	Housing, Differential
4	AA-53-2807W	1	Tube, Long Axle
5	CA-53-2809	1	Housing, Coupling
6	A-1B-1548	1	Coupling, Spline
7	B-1B-1548	1	Adaptor, Spline
8	20V47	6	9/16"-12 x 2" Hex Head Cap Screw
9	27X64	1	Differential Head Assembly (See Section 12 For Breakdown)
10	28L27	1	Electric Shift Unit (See Section 12 For Breakdown)
11	27X66	1	Planetary, Two Speed (See Section 12 For Breakdown)
12	27L83	6	9/16" Lock Washer
14	EA-53-2808	1	Axle, Long
15	DA-53-2808	1	Axle, Short
16	15V38	2	Bearing Assembly
17	30S04	2	Seal, Inner
18	30T51	2	Seal, Outer
19	31A37	2	Ring, Retaining
20	50N31	2	Sleeve, Wear
21	CM-53-2505	2	Spacer
22	AA-53-2809	2	Brake, Disc
23	A-19-2468	2	Sprocket, 11T.
24	ZF-17-9	6	Shims .0598"
25	X-53-1281	2	Cap, End
26	BS-17-59	4	1/2" x 1.25" Hex Head Cap Screw (Drilled Head)
28	23G30	1	Breather, 3/4" N.P.T. (Ship Loose)
	23D16	1	Plug, 3/4" N.P.T. Pipe (For Storage)
30	23D07	1	Plug, 3/4" Mag. Drain
31	AD-53-2678	1	Ring, Lifting
32	23C60	1	Fitting, 1/8" N.P.T.
33	23C66	1	Fitting, 1/8" N.P.T., 90°
34	23D12	1	Plug, 1/2" N.P.T. Pipe
35	23D19	1	Plug, 1" N.P.T. Pipe
37	26E24	4	1/2" x 1" Hex Head Cap Screw (For Storage Cover)
38	26C54	2	1/2" x 2" Hex Head Cap Screw
39	26E29	10	1/2" x 1-1/2" Hex Head Cap Screw
40	27L81	12	1/2" Lock Washer
41	15S88	4	3/4" x 1-3/4" Hex Head Cap Screw
42	27L87	4	3/4" Lock Washer
43	X-26-46	1	Cover, Storage
44	B-53-1794	1	Shim, .015" (Aluminum)
45	27L58	3	1/2" Cut Washer
47	D-16-296	1	Plate, Repair Parts

REF.	PART NUMBER	QTY.	DESCRIPTION
48	26A76	1	Drive Screw #4
50	28L44	1	Relief, 1/8" N.P.T. Lube
51	13E43	1	Bushing, 1/4" to 1/8" N.P.T. Reducing

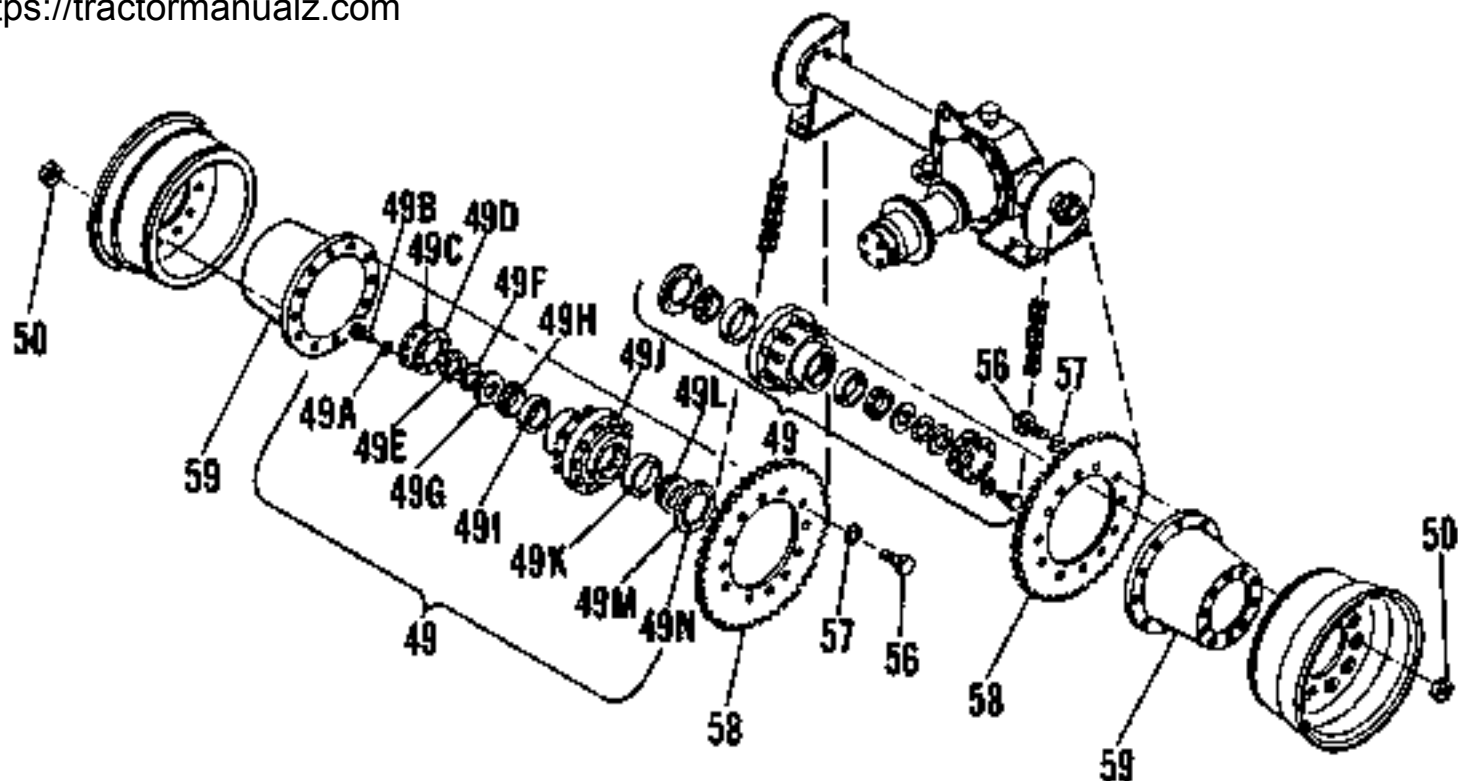

WHEEL, HUB & SPROCKET

D-876-5430B

(Before Ordering, Consult Table of Contents to Verify Proper Bill of Material Number.)

REF.	PART NUMBER	QTY.	DESCRIPTION
49	13X80	2	Hub Group (Consisting of the following indented items):
49A		8	. Lock Washer
49B		8	. Cap Screw
49C		1	. Cap, Hub
49D	13X80C5	1	. Gasket
49E		1	. Nut, Wheel Bearing (Outer)
49F		1	. Ring, Locking
49G		1	. Nut, Wheel Bearing (Inner)
49H	30H113	1	. Cone, Bearing
49I	30H112	1	. Cup, Bearing
49J		1	. Hub & Stud Assembly (Each Assembly consisting in part of the following indented item):
	14R93	10	.. Stud
49K	13X80C3	1	. Cup, Bearing
49L	13X80C4	1	. Cone, Bearing
49M	13X80C1	1	. Wiper, Oil Seal
49N	13X80C2	1	. Seal Assembly, Oil
50	12P37	20	Wheel Nut
56	26C54	24	1/2" x 2" Hex Head Cap Screw
57	27L81	24	1/2" Lock Washer
58	A-19-2469	2	Sprocket, 57T.
59	AA-876-5433	2	Hub Casting, Sprocket

5/1/90 (I-B)

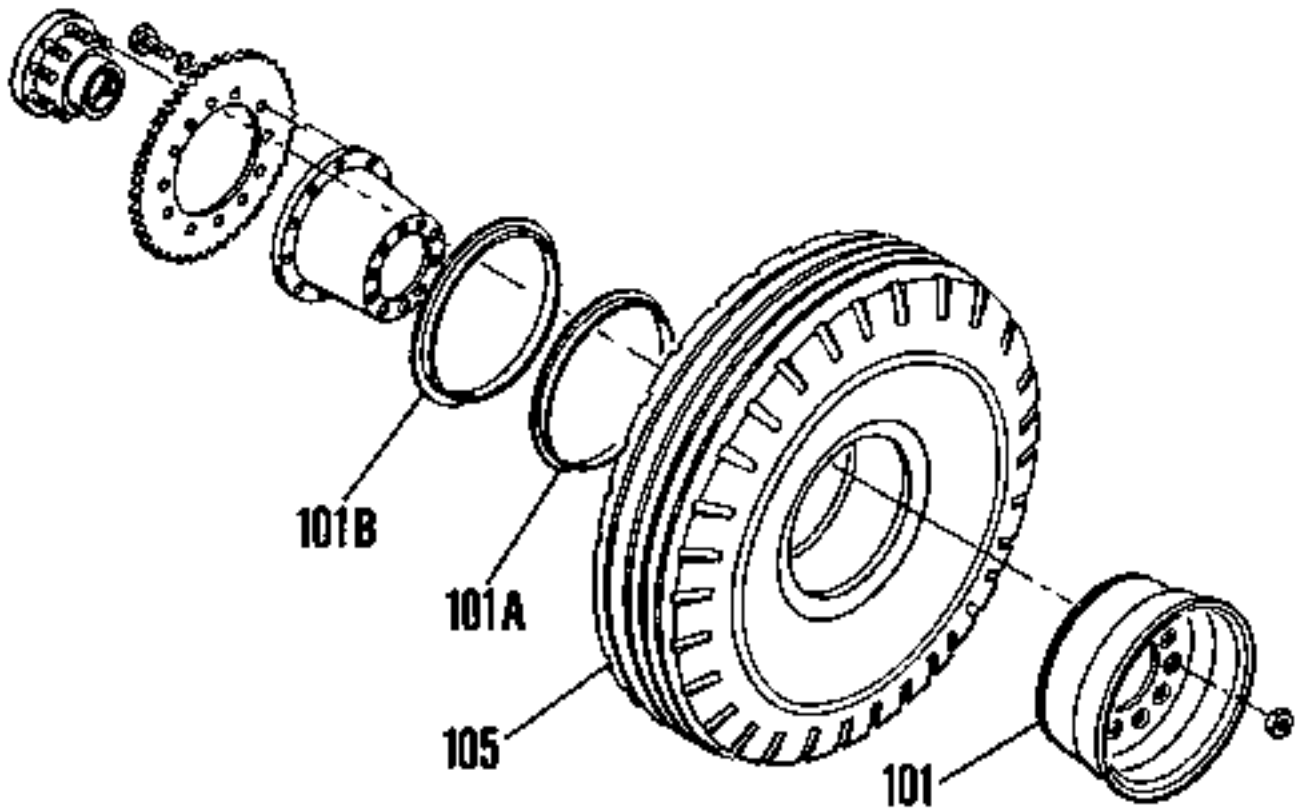

WHEEL RIM & TIRE

C-876-5430B

(Before Ordering, Consult Table of Contents to Verify Proper Bill of Material Number.)

REF.	PART NUMBER	QTY.	DESCRIPTION
	E-876-5430A	2	Tire Assembly (Each Assembly Consisting of the following indented items):
101	A-876-5432W	1	. Rim, Drive Wheel
101 A	28K69	1	. Flange, Side
101B	28K70	1	. Ring, Locking
105	27Y39	1	. Tire
	20M53	120	. Calcium Chloride Pellets (For solution filling of tires) (Qty. indicated is number of pounds required)

5/1/93 (1-6)

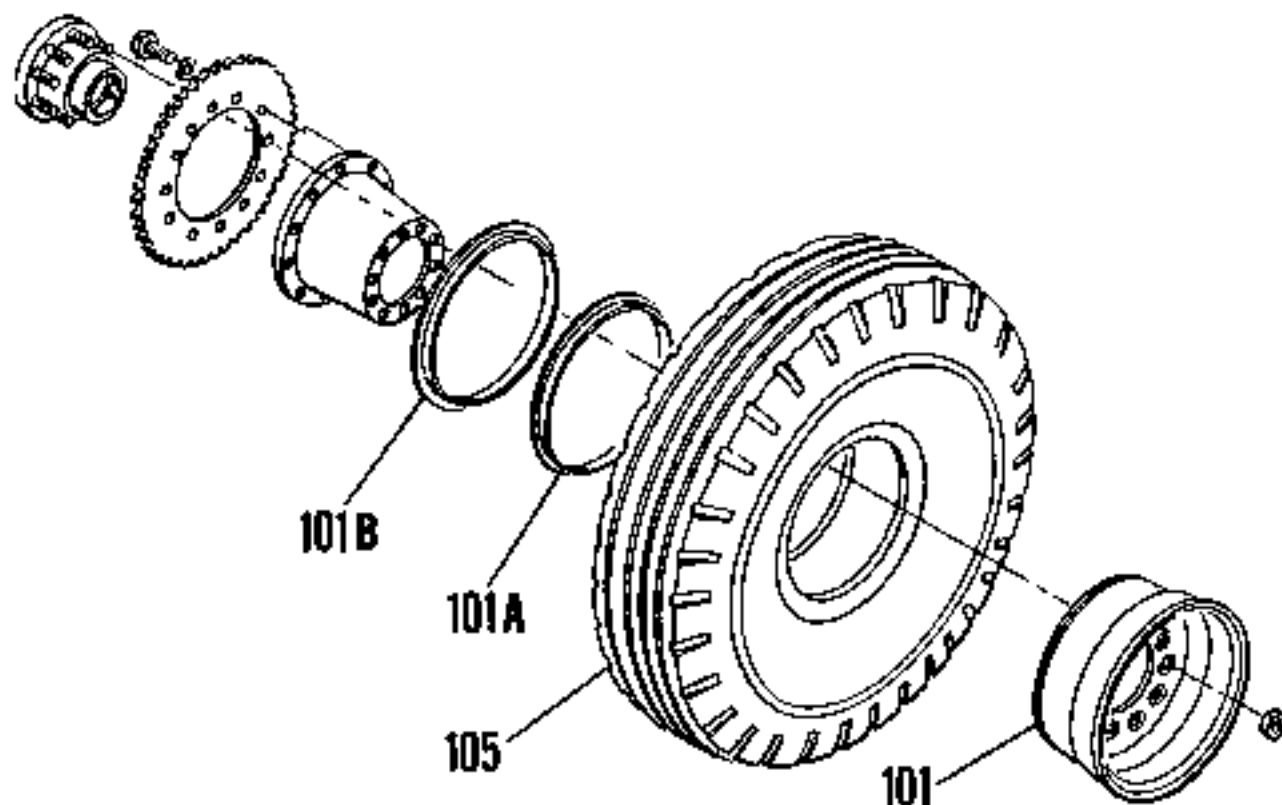

WHEEL RIM & TIRE

C1-876-5430B

(Before Ordering, Consult Table of Contents to Verify Proper Bill of Material Number.)

REF.	PART NUMBER	QTY.	DESCRIPTION
	E1-876-5430A	2	Tire Assembly (Each Assembly Consisting of the following indented items):
101	A1-876-5432W	1	· Rim, Drive Wheel
101A	SA-876-5433	1	· Flange, Side
101B	28K70	1	· Ring, Locking
105	27Y39	1	· Tire
	20M53	120	· Calcium Chloride Pellets (For solution filling of tires) (Qty. indicated is number of pounds required)

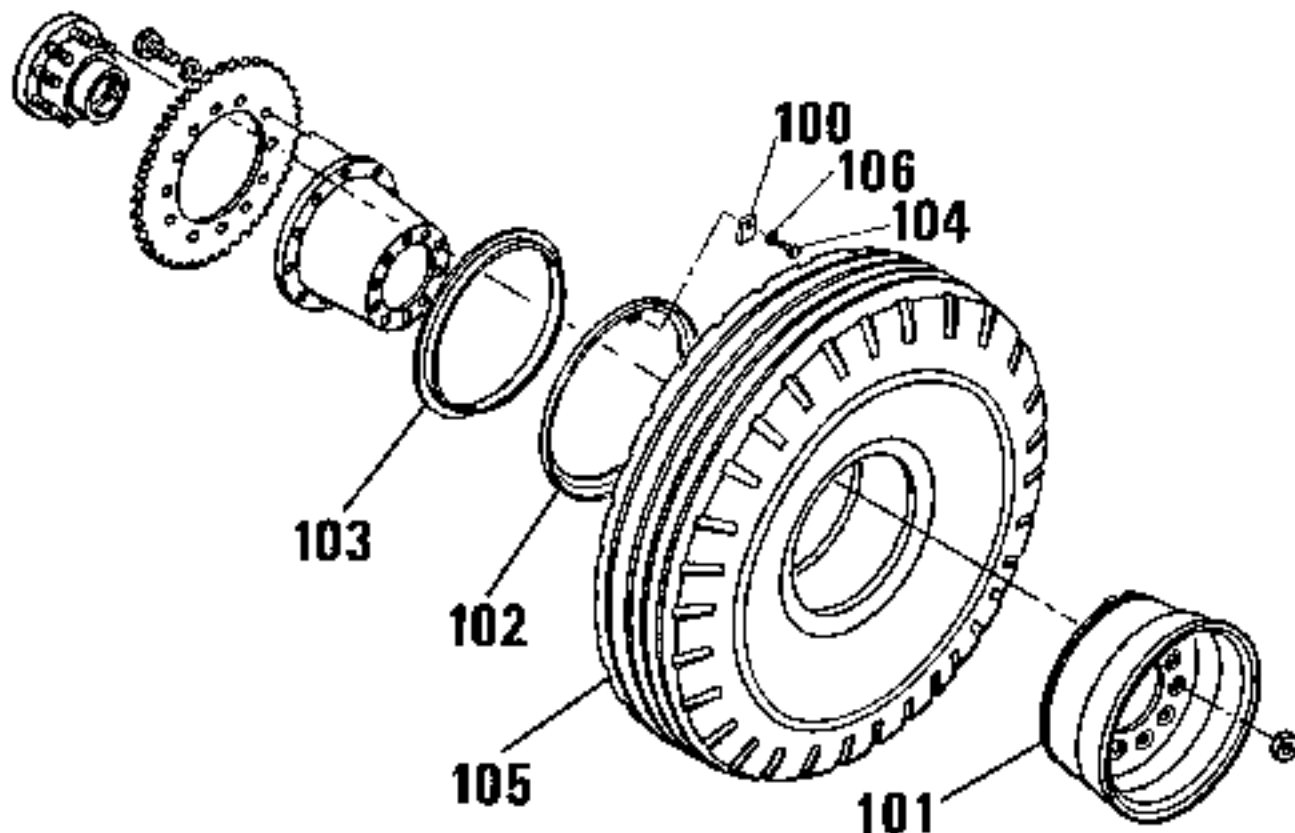

WHEEL RIM & TIRE

C2-876-5430B

(Before Ordering, Consult Table of Contents to Verify Proper Bill of Material Number.)

REF.	PART NUMBER	QTY.	DESCRIPTION
	E7-876-5430A	2	Tire Assembly (Each Assembly Consisting of the following indented items):
100	SB-876-5433	1	• Plate, Lock
101	A2-876-5432W	1	• Rim, Drive Wheel
102	1 A-876-5432W	1	• Flange, Side
103	28K70	1	• Ring, Locking
104	26C53	1	• 3/8" x 1" Hex Head Cap Screw
105	27Y39	1	• Tire
106	27L78	1	• 3/8" Lock Washer
	20M53	120	• Calcium Chloride Pellets (For solution filling of tires) (Qty. indicated is number of pounds required)

PARKING & TRAVEL BRAKE
(Illustration 1 of 3)
D3-876-5430B

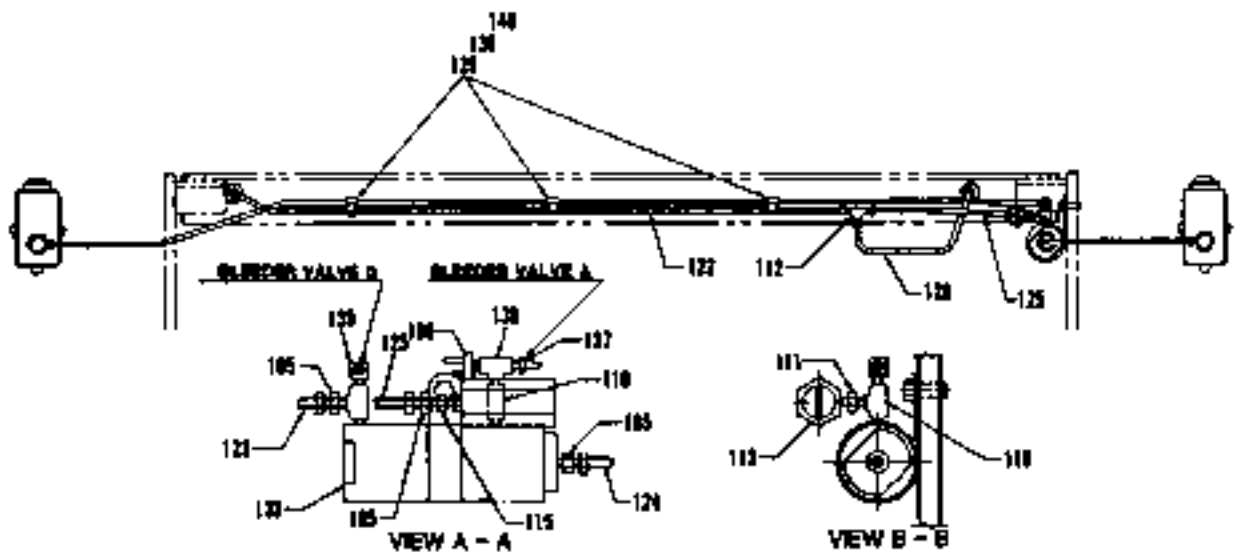
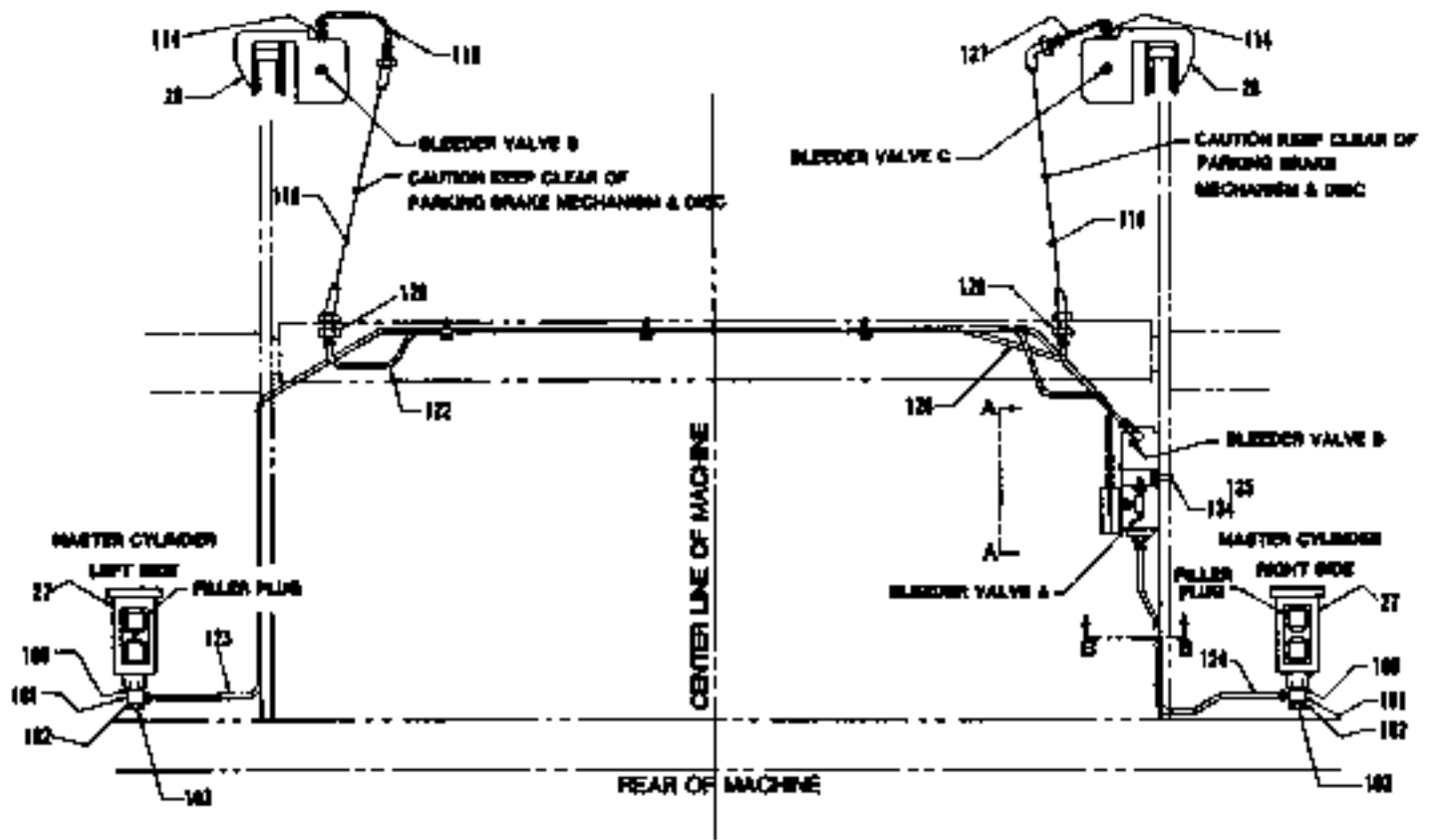

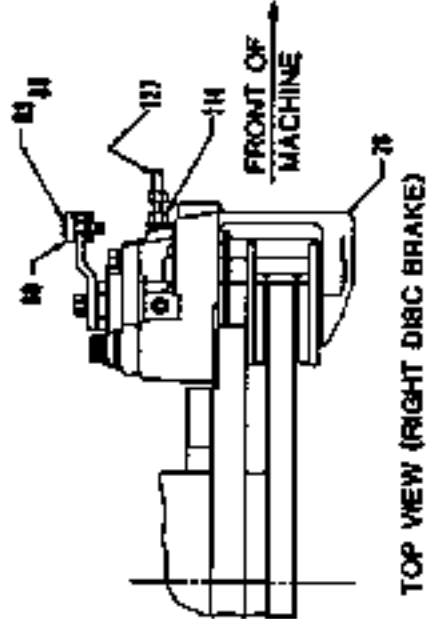
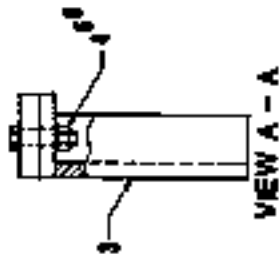
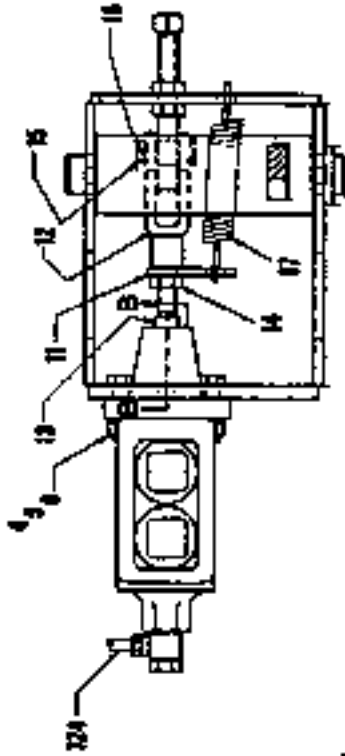
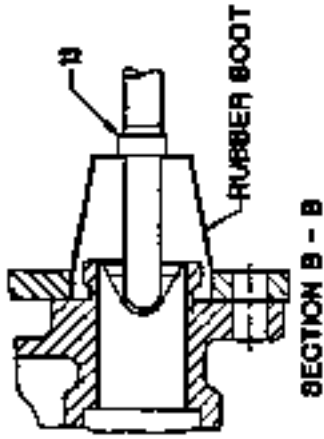

PARKING & TRAVEL BRAKE
(Illustration 2 of 3)
D3-876-543(0B)

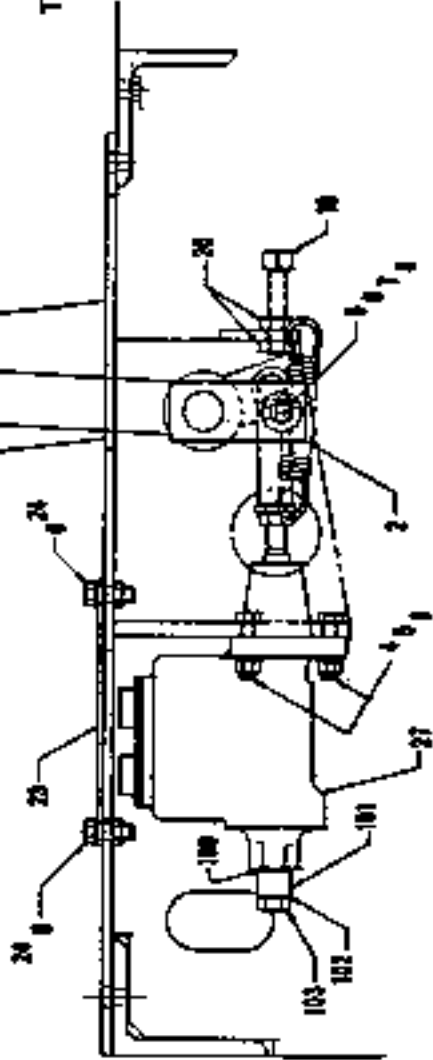

PARKING & TRAVEL BRAKE
(Illustration 3 of 3)
D3-876-5430B

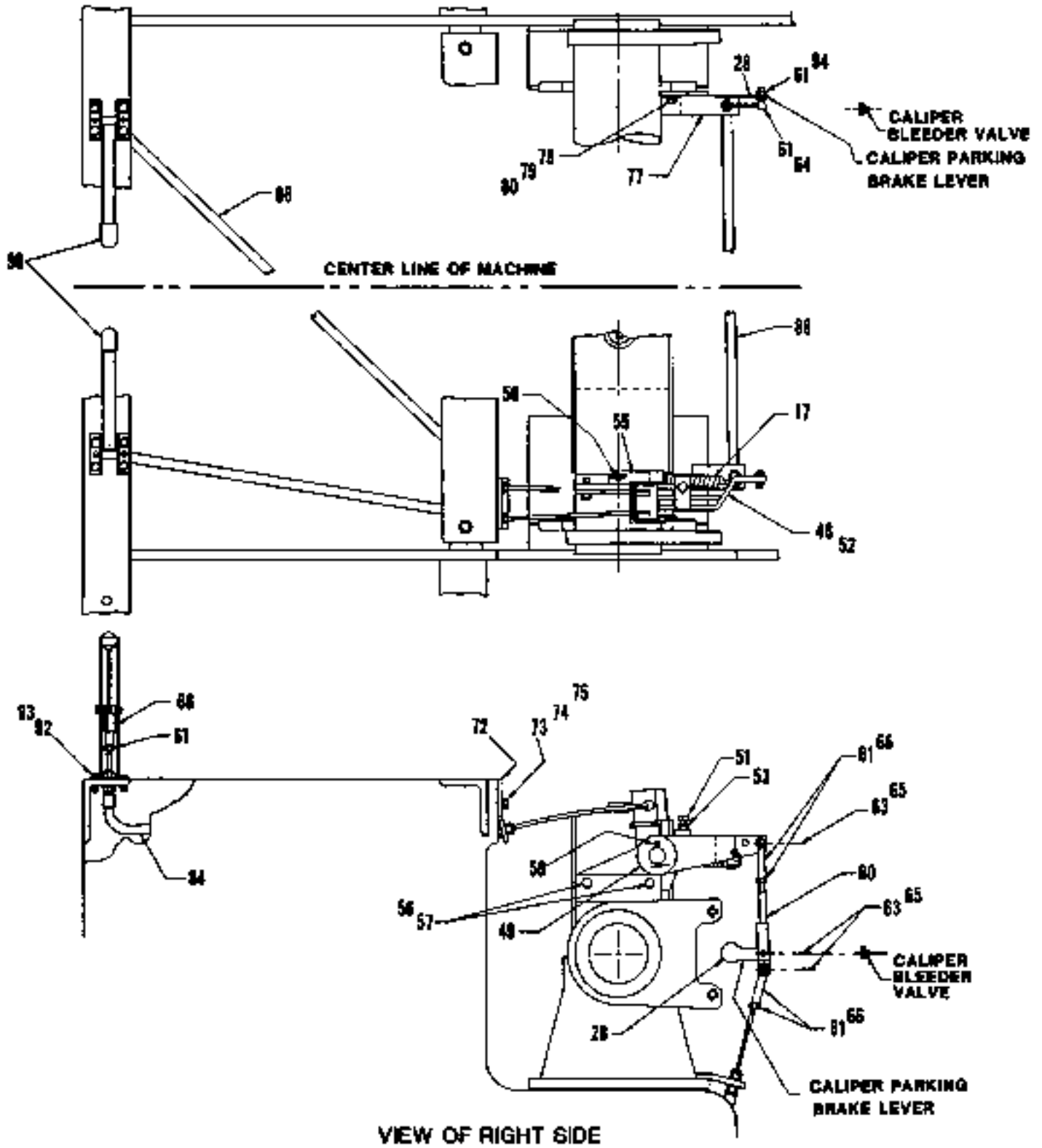

PARKING & TRAVEL BRAKE

D3-876-5430B

(Before Ordering, Consult Table of Contents to Verify Proper Bill of Material Number.)

REF.	PART NUMBER	QTY.	DESCRIPTION
Ref. #1 thru #140 Symbolized by NONE on Illustrations 1, 2 & 3.			
1	AA1-876-5432W	2	Lever, Brake
2	AB-876-5432W	2	Shaft, Pedal
3	AC-876-5432W	2	Pedal, Brake
4	10V14	10	3/8" x 1-1/2" Hex Head Cap Screw
5	27C90	12	3/8" Nut
6	27L78	16	3/8" Lock Washer
7	10E10	2	3/8" x 1-1/4" Hex Head Cap Screw
8	27L56	2	3/8" Cut Washer
11	CG-876-5433	2	Plate, Spring
12	50D80	2	Clevis, Rod End
13	CA-876-5433	2	Rod, Push
14	27D20	2	1/2" Jam Nut
15	50D91	2	Pin, Clevis
16	27D53	2	Pin, 1/8" x 1" Cotter
17	D-46-190	3	Spring
19	27N41	2	1/2" x 2-1/4" Square Head Set Screw
20	27D21	4	1/2" Jam Nut
23	DA1-876-5433	2	Plate, Cover
24	26C53	4	3/8" x 1" Hex Head Cap Screw
27	28F39	2	Brake, Master Cylinder (See Section 12 For Breakdown)
28	28F59	2	Disc Brake Assembly (See Section 12 For Breakdown)
48	BA-876-5432W	1	Crank, Bell
49	27L62	1	1" Washer
50	27D64	2	Pin, 3/16" x 1-1/2" Cotter
51	27K33	1	3/8" x 1-1/2" Square Head Set Screw
52	23C64	1	Fitting, 45° x 1/8" N.P.T. Grease
53	27C90	1	3/8" Hex Nut
55	BB-876-5432W	1	Pivot
56	26C53	2	3/8" x 1" Hex Head Cap Screw
57	27L78	2	3/8" Lock Washer
60	BC-876-5432W	1	Linkage
61	27C88	6	5/16"-24 U.N.F. Nut
63	27D48	3	Pin, 3/32" x 3/4" Cotter
64	15T85	1	Joint, 5/16"-24 U.N.F. Ball
65	50D88	3	Pin, Clevis
66	50D77	4	Clevis, 5/16"
72	LA-876-5433	1	Support, Cable
73	26C53	2	3/8" x 1" Hex Head Cap Screw
74	27L56	2	3/8" Cut Washer
75	27L78	2	3/8" Lock Washer
77	BD-876-5432W	1	Cable, Anchor
78	26C53	2	3/8" x 1" Hex Head Cap Screw

REF.	PART NUMBER	QTY.	DESCRIPTION
79	27L56	2	3/8" Cut Washer
80	27L78	2	3/8" Lock Washer
84	28L29	1	Cable, Pull x 47-3/4"
86	28L30	1	Cable, Pull x 77-3/4"
88	28F58	1	Cable, Push-Pull x 73"
90	50F06	2	Lever, Hand Brake
92	23V67	8	5/16"-18 U.N.F. x 1" Hex Head Cap Screw
93	14Z77	8	5/16"-18 U.N.F. Lock Nut
94	27L77	1	5/16" Lock Washer
100	50G43	2	Gasket, Copper
101	50R05	2	Connector
102	50G44	2	Gasket, Copper
103	23J47	2	Connector, Bolt
105	23B01	3	Connector, 1/4" T. to Male 1/8" N.P.T.F.
108	10W98	1	Switch (Brake Pressure)
110	26J66	1	Tee, Service x 1/8" N.P.T.F.
111	23N77	1	Nipple, Pipe x 1/8" N.P.T.F.
112	28G15	1	Tee, Inverted Flare Union
113	28M88	1	Gauge, Protector (1000 PSI)
114	28G16	2	Adopter
115	23A10	1	Bushing, Reducer - 1/8" Fe. N.P.T.F. x 1/4" M. N.P.T.F.
116	C-80-579W	1	Tube Assembly
118	23H71	2	Hose Assembly
120	27D23	2	5/8"-18 U.N.F. Jam Nut
122	C-80-578W	1	Tube Assembly
123	A-80-578W	1	Tube Assembly
124	D-80-578W	1	Tube Assembly
125	A-80-596W	1	Tube Assembly
126	C-80-582W	1	Tube Assembly
127	A-80-579W	1	Tube Assembly
129	F-46-347	3	Clamp, Double 1/4" O.D. Tube
130	27L76	3	1/4" Lock Washer
133	28G32	1	Valve, Selector
134	26C53	1	3/8" x 1" Hex Head Cap Screw
135	27L78	1	3/8" Lock Washer
137	28L24	1	Valve, Bleeder
138	28L25	1	Tee, Male Branch
139	23J52	1	Elbow, 90° x 1/8" N.P.T.F.
140	26C69	3	1/4" x 1" Hex Head Cap Screw

SECTION 3

BG-220B Asphalt Paver

PUSH ROLLERS & TRUCK HITCH

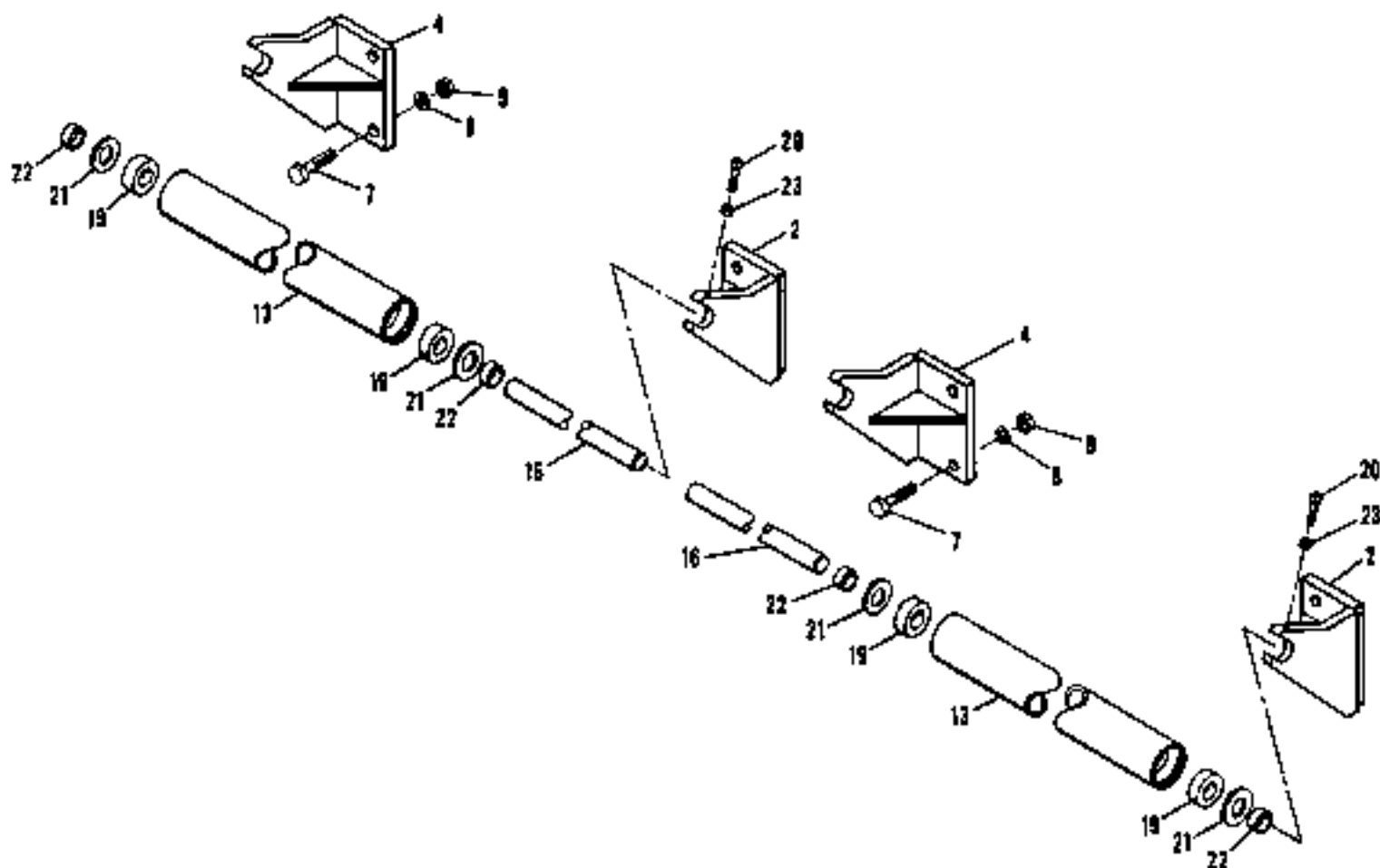

FIXED PUSH ROLLER

A-876-5240B

(Before Ordering, Consult Table of Contents to Verify Proper Bill of Material Number.)

REF.	PART NUMBER	QTY.	DESCRIPTION
2	A-876-5242W	2	Support, Fixed Push Roller
4	AA-876-5242W	2	Support, Fixed Push Roller
7	13V88	8	3/4" x 3" Hex Head Cap Screw
8	27L87	9	3/4" Lock Washer
9	27D01	8	3/4" Nut
13	A-876-1878	2	Roller
16	B1-876-1878	2	Shaft, Roller
19	12534	4	Bearing, Ball - 1.50" Dia.
20	27L17	4	3/8" x 1.50" Set Screw
21	CR-17-478	4	1.53" I.D. Washer
22	CS-17-478	4	1.53" I.D. Washer
23	27D17	4	3/8" Jam Nut

5/1/90 (1-9)

SECTION 3 PAGE 1

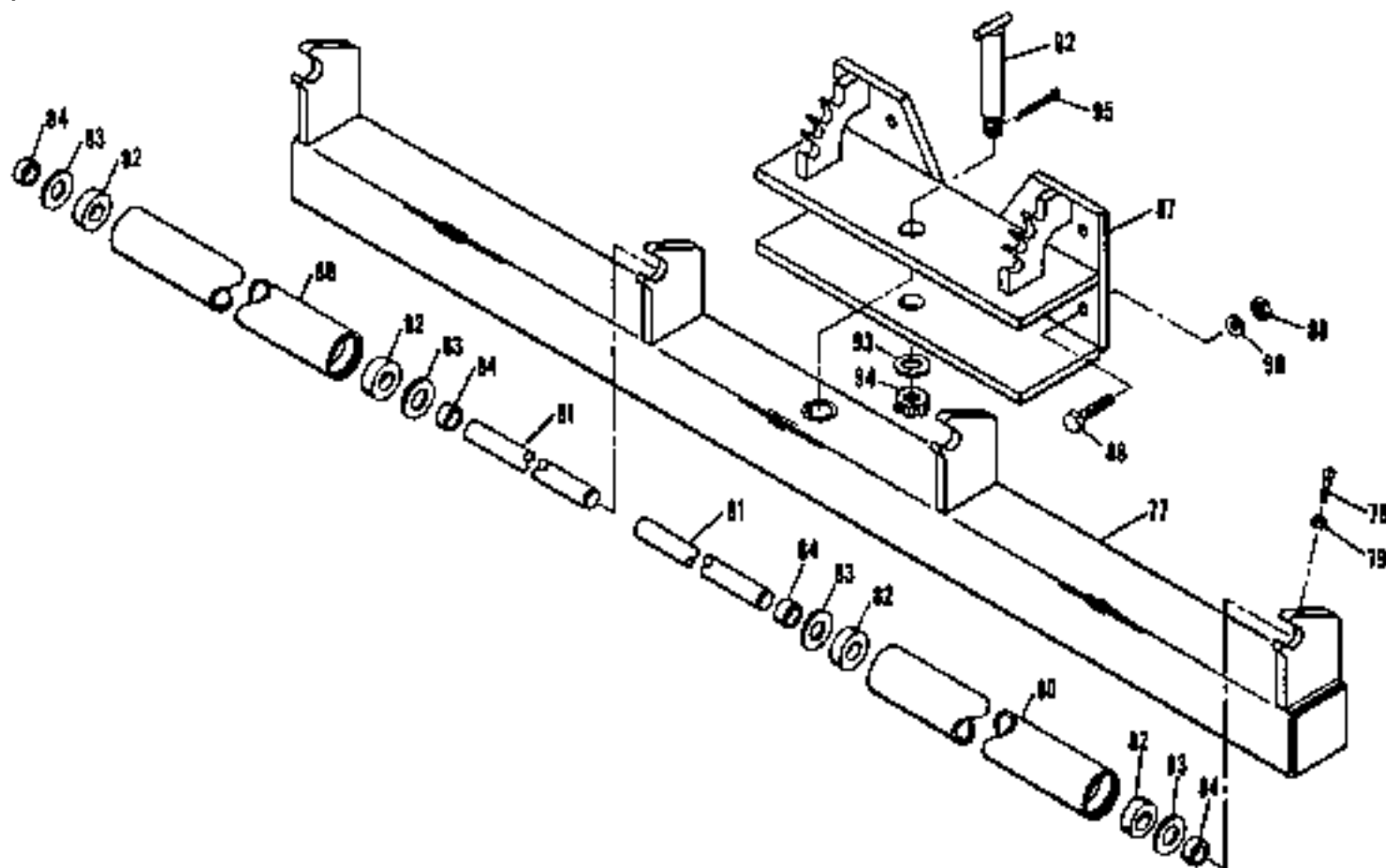

OSCILLATING PUSH ROLLER

C-876-5240B

(Before Ordering, Consult Table of Contents to Verify Proper Bill of Material Number.)

REF.	PART NUMBER	QTY.	DESCRIPTION
77	CA-876-5242W	1	Frame, Oscillating Push Roller
78	27L17	4	3/8" x 1-1/2" Socket Set Screw
79	27D17	4	3/8" Jam Nut
80	AA-876-5243	2	Roller
81	AB-876-5243	2	Shaft, Roller
82	12S34	4	Bearing
83	CR-17-478	4	Washer, 1.53 I.D.
84	CS-17-478	4	Washer, 1.53 I.D.
97	AA1-876-1867W	1	Support, Push Roller
88	26F57	6	3/4" x 3" Bolt w/Nut
90	27L87	6	3/4" Lock Washer
92	FI-876-1867W	1	Pin
93	27L64	1	1-1/4" Cut Washer
94	26C18	1	1-1/4" Slotted Nut
95	27D75	1	Pin, 1/4" x 2-1/2" Collar

5/1/90 (1-9)

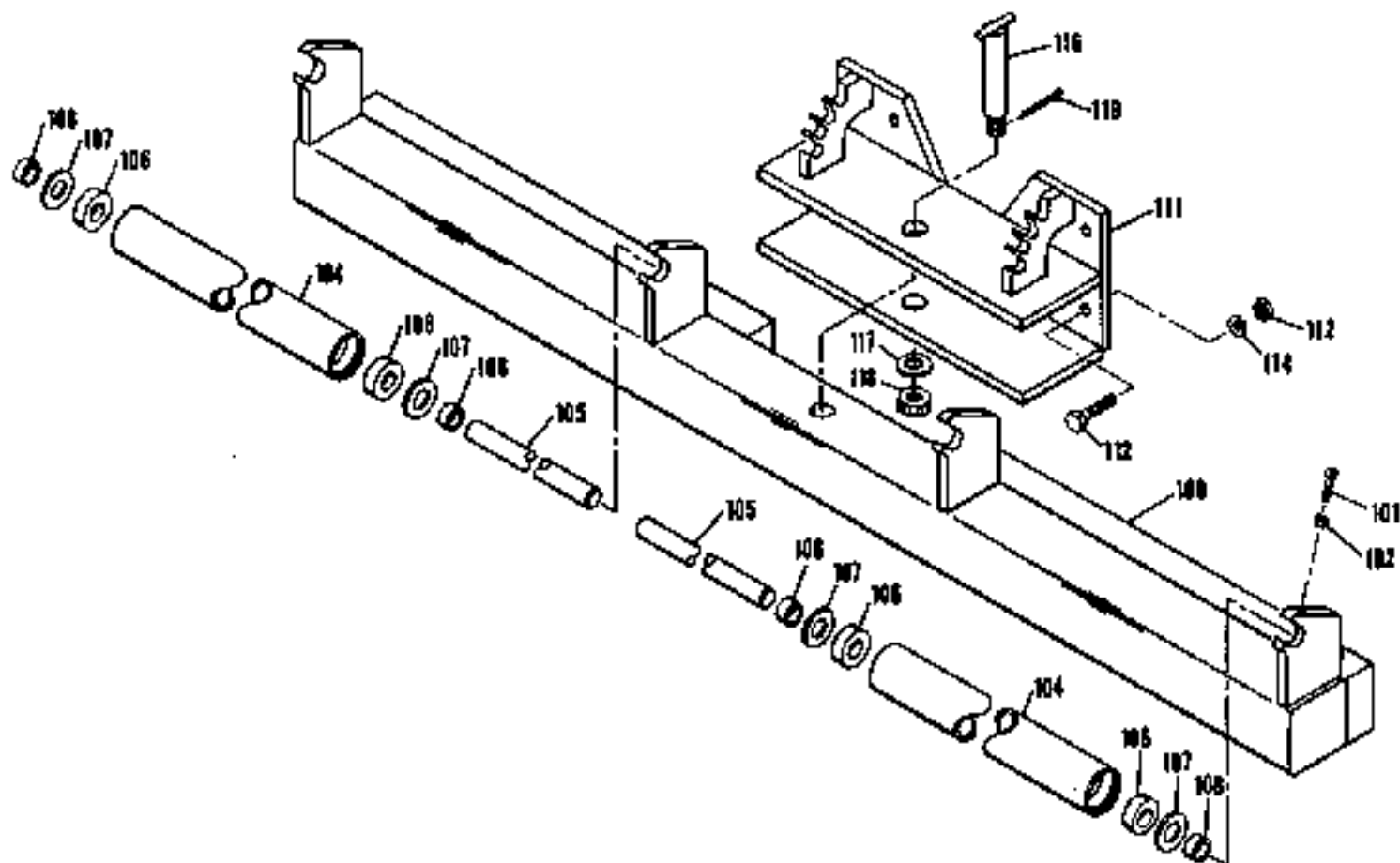

WEIGHTED OSCILLATING PUSH ROLLER

D-876-5240B

(Before Ordering, Consult Table of Contents to Verify Proper Bill of Material Number.)

REF.	PART NUMBER	QTY.	DESCRIPTION
100	BA-876-5242W	1	Frame, Push Roller (Weighted)
101	27L17	4	3/8" x 1-1/2" Socket Set Screw
102	27D17	4	3/8" Jam Nut
104	AA-876-5243	2	Roller
105	AB-876-5243	2	Shaft, Roller
106	12534	4	Bearing
107	CR-17-478	4	Washer, 1.53 I.D.
108	CS-17-478	4	Washer, 1.53 I.D.
111	AA1-876-1867W	1	Support, Push Roller
112	26F57	6	3/4" x 3" Bolt w/Nut
114	27L87	6	3/4" Lock Washer
116	PI-876-1867W	1	Pin
117	27L64	1	1-1/4" Cut Washer
118	26C18	1	1-1/4" Slotted Nut
119	27D75	1	Pin, 1/4" x 2-1/2" Cotter

5/1/90 (1-9)

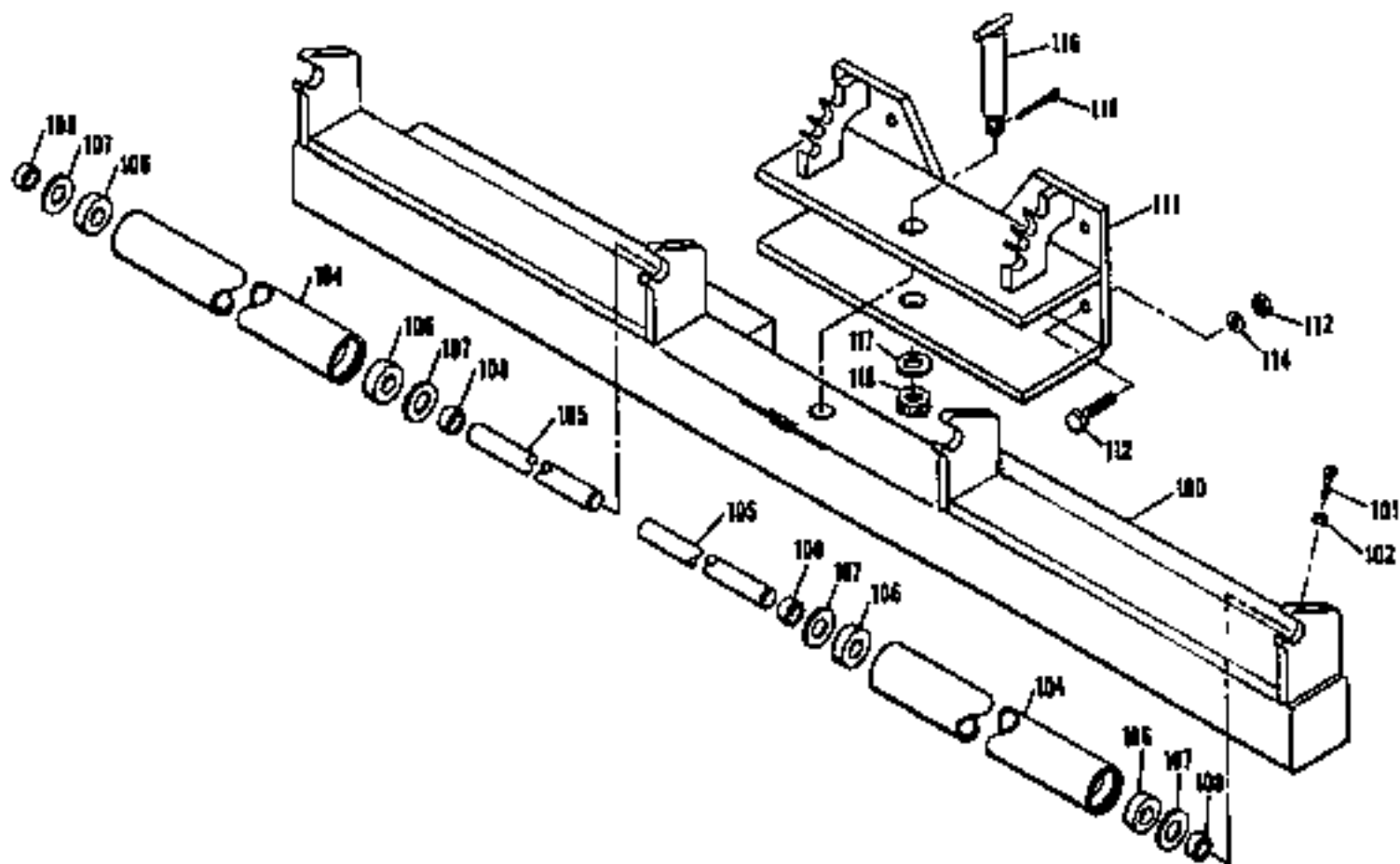

WEIGHTED OSCILLATING PUSH ROLLER

BH-876-5240B

(Before Ordering, Consult Table of Contents to Verify Proper Bill of Material Number.)

REF.	PART NUMBER	QTY.	DESCRIPTION
100	LA-876-5242W	1	Frame, Push Roller (Weighted)
101	27L17	4	3/8" x 1-1/2" Socket Set Screw
102	27D17	4	3/8" Jam Nut
104	AA-876-5243	2	Roller
105	AB-876-5243	2	Shaft, Roller
106	12534	4	Bearing
107	CR-17-478	4	Washer, 1.53" I.D.
108	CS-17-478	4	Washer, 1.53" I.D.
111	AA1-876-1867W	1	Support, Push Roller
112	10525	6	3/4" x 4" Bolt (With Nut)
114	27L87	6	3/4" Lock Washer
116	F1-876-1867W	1	Pin
117	27L64	1	1-1/8" Cut Washer
118	26C18	1	1-1/4" Slotted Nut
119	27D73	1	Pin, Cotter - 1/4" x 2-1/2"

IMPLEMENTS

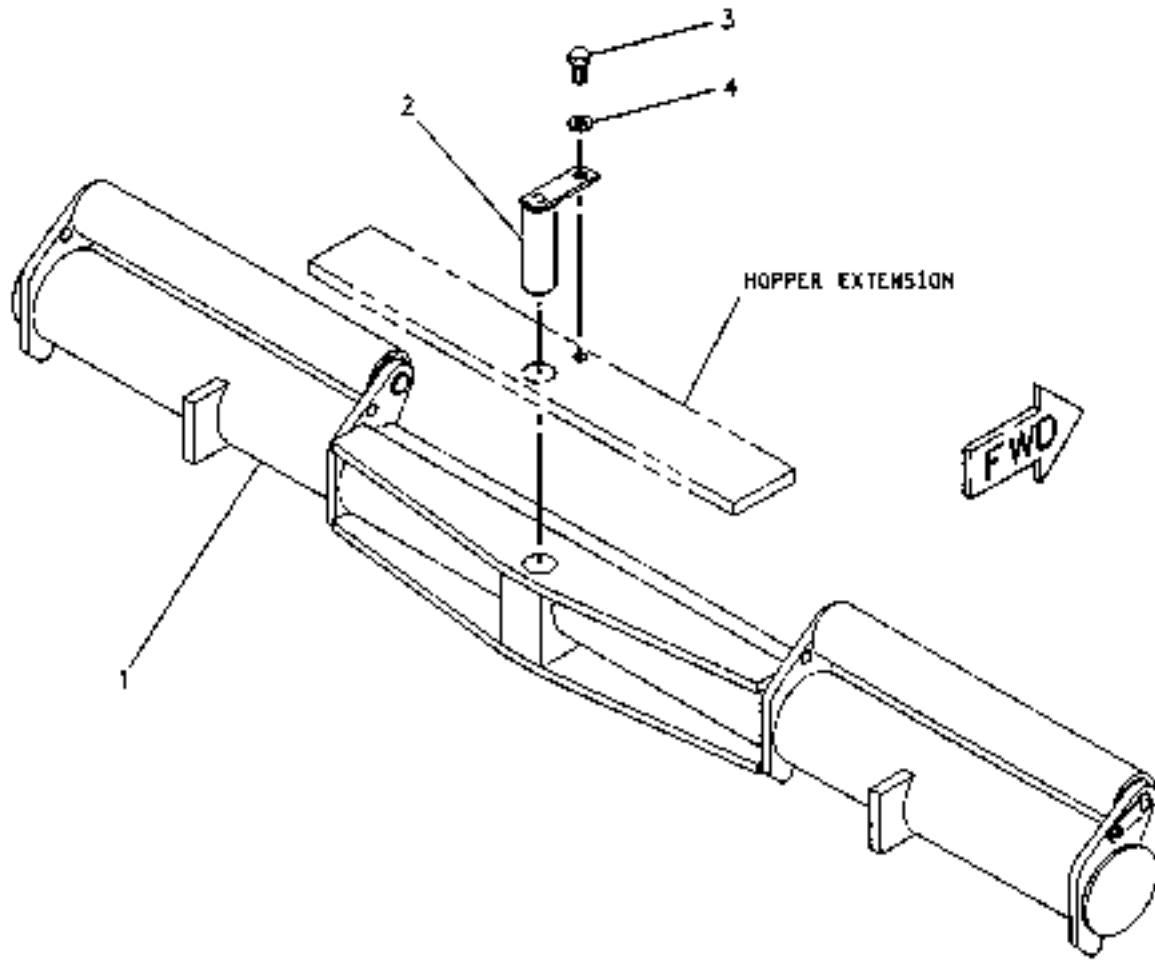

NOTE	REF NO	PART NUMBER	QTY	PART NAME
Y	1	112-0896	1	PUSH ROLLER GP - WEIGHTED (8'-0")
	2	81-0567	1	PIN, PIVOT
	3	5C-6266	1	BOLT
	4	8T-4122	1	HARD WASHER

Y - SEPARATE ILLUSTRATION

8/26/94 (1-0)

112-0897 PUSH ROLLER AR

IMPLEMENTS

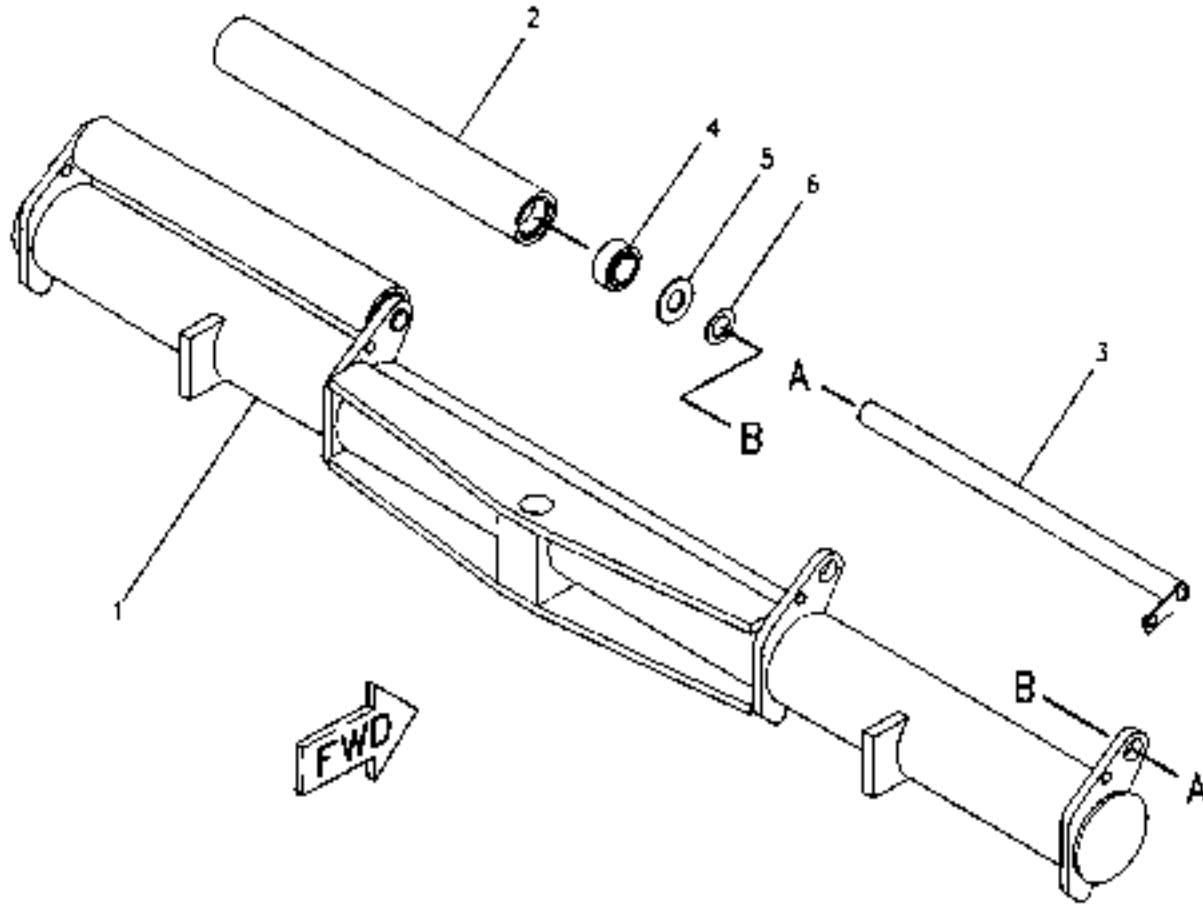

NOTE	REF NO	PART NUMBER	QTY	PART NAME
	1	112-0895	1	PUSH ROLLER AS - WEIGHTED
	2	102-6663	2	ROLLER
	3	102-6664	2	SHAFT, ROLLER
	4	6I-9487	4	BEARING
	5	8I-0625	4	WASHER
	6	8I-0626	4	WASHER
	7	7X-0348	2	BOLT
	8	8T-4122	2	HARD WASHER
	9	7X-0448	2	NUT

B/26/84 (1-1)

112-0896 PUSH ROLLER GP
Part Of 112-0897 - Push Roller Ar

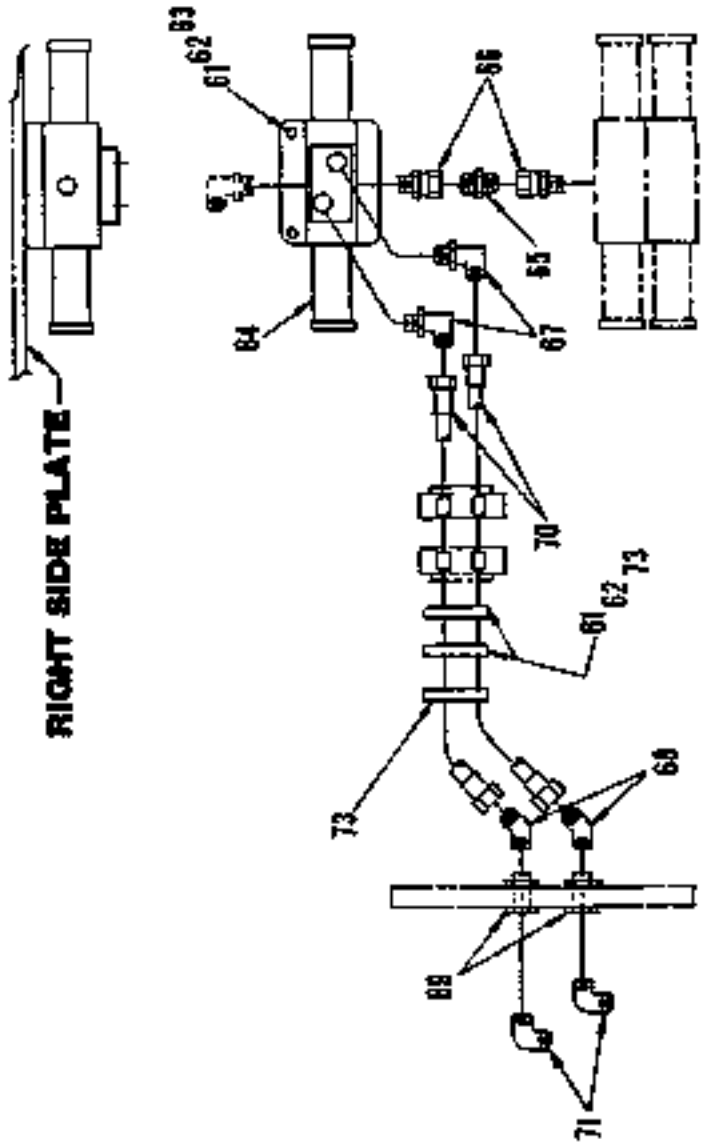

LAYTON TRUCK HITCH
(With Hydraulics & Electrical)
B-876-5240B

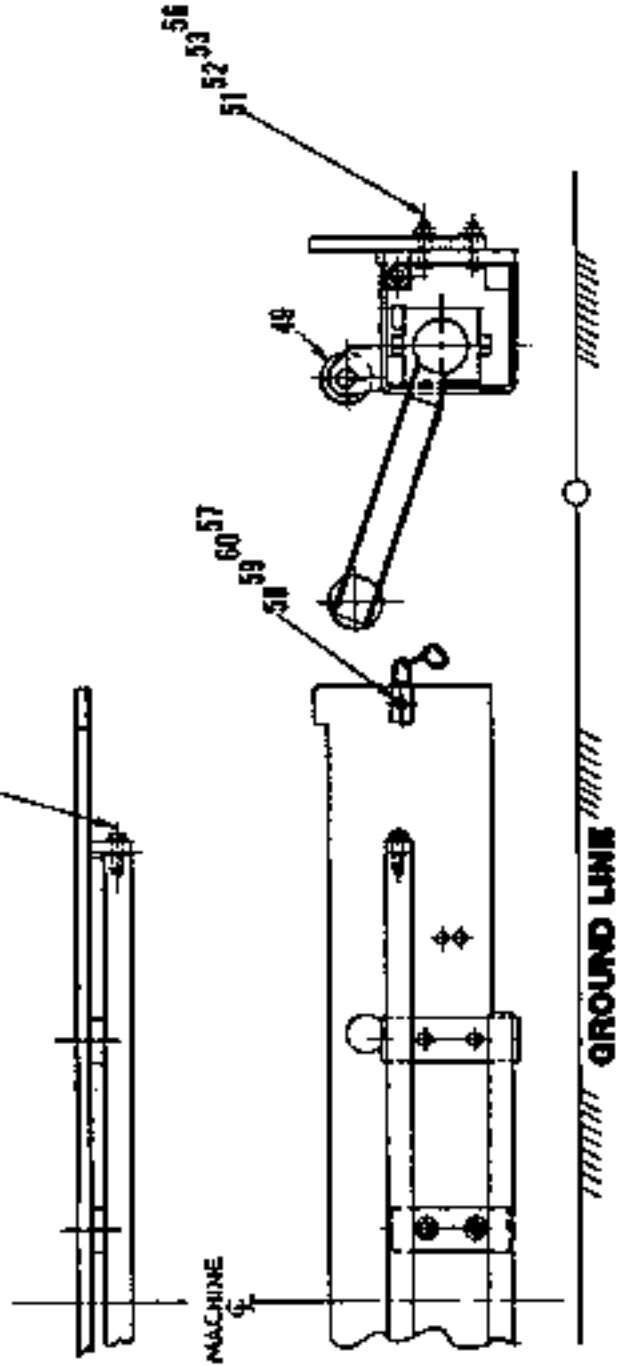

**LAYTON TRUCK HITCH
(With Hydraulics & Electrical)**

B-876-5240B

(Before Ordering, Consult Table of Contents to Verify Proper Bill of Material Number.)

REF.	PART NUMBER	QTY.	DESCRIPTION
Ref. #49 thru #73 Symbolized by NONE on Illustration.			
49	13P76	1	Hitch, Truck (See Separate Manual)
	20P55	2	Switch (Located on Operator's Station)
51	13V88	8	3/4" x 3" Hex Head Cap Screw
52	27D01	8	3/4" Hex Nut
53	27L60	8	3/4" Cut Washer
54	15588	2	3/4" x 1.75" Hex Head Cap Screw
55	CA-876-5243	2	Block, Bumper
56	27L87	10	3/4" Lock Washer
57	27L59	8	5/8" Cut Washer
58	12T10	4	5/8" x 2.75" Hex Head Cap Screw
59	27C98	4	5/8" Hex Nut
60	27L84	4	5/8" Lock Washer
61	13J31	3	1/4" x 3/4" Hex Head Cap Screw
62	27L76	3	1/4" Lock Washer
63	27L52	2	1/4" Cut Washer
64	26N60	1	Valve, Solenoid (See Section 12 For Breakdown)
65	23C86	1	Nipple, 1/2" N.P.T.F.
66	23K89	2	Connector, 1/2" N.P.S.M. x 3/4"-16 Str.
67	14L07	2	Elbow, 90° - 3/8" T. x 3/4"-16 Str.
68	14C17	2	Elbow, 45° - 1/4" N.P.T.F. x 3/8" T.
69	11M91	2	Terminal Bolt
70	CL-80-482W	2	Hose, 3/8" I.D. x 186"
71	13R85	2	Elbow, 90° - 1/4" N.P.T.F. x 5/16" T.
73	20K38	3	Clamp

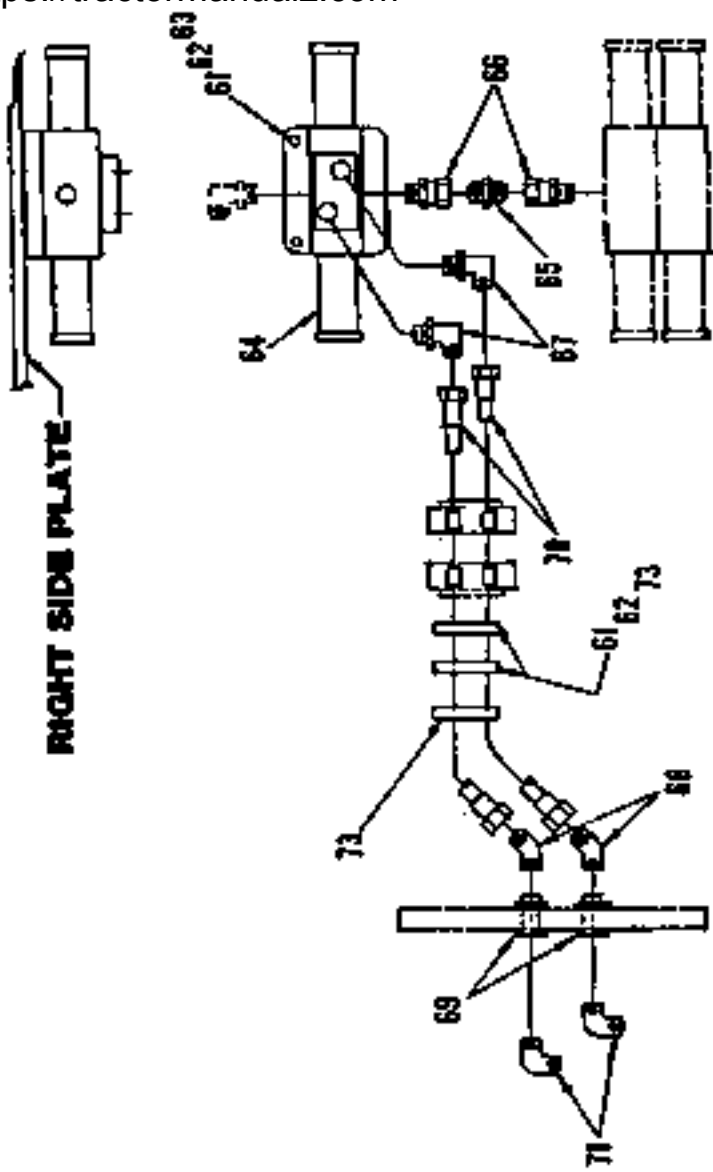

LAYTON TRUCK HITCH
(With Hydraulics & Electrical)
BI-876-529DB

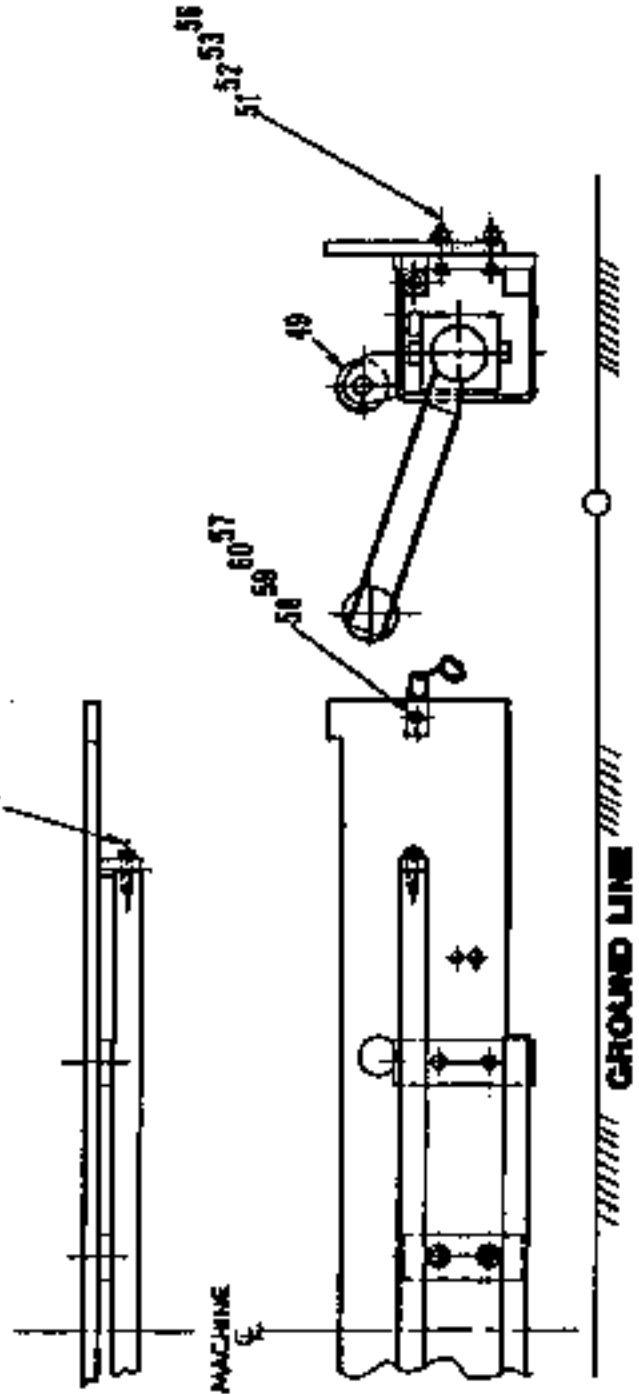

**LAYTON TRUCK HITCH
(With Hydraulics & Electrical)**

BI-876-5240B

(Before Ordering, Consult Table of Contents to Verify Proper Bill of Material Number.)

REF.	PART NUMBER	QTY.	DESCRIPTION
Ref. #49 thru #73 Symbolized by NONE on Illustration.			
49	29E85	1	Hitch, Truck (See Separate Manual)
	20P55	2	Switch (Located on Operators Station)
51	13V88	8	3/4" x 3" Hex Head Cap Screw
52	27D0F	8	3/4" Hex Nut
53	27L60	8	3/4" Cut Washer
54	15S88	2	3/4" x 1.75" Hex Head Cap Screw
55	CA-876-5243	2	Black, Bumper
56	27L87	10	3/4" Lock Washer
57	27L59	8	5/8" Cut Washer
58	12T10	4	5/8" x 2.75" Hex Head Cap Screw
59	27C98	4	5/8" Hex Nut
60	27L84	4	5/8" Lock Washer
61	13J31	3	1/4" x 3/4" Hex Head Cap Screw
62	27L76	3	1/4" Lock Washer
63	27L52	2	1/4" Cut Washer
64	26N60	1	Valve, Solenoid (See Section 12 For Breakdown)
65	23C86	1	Nipple, 1/2" N.P.T.F.
66	23K89	2	Connector, 1/2" N.P.S.M. x 3/4"-16 Str.
67	14L07	2	Elbow, 90° - 3/8" T. x 3/4"-16 Str.
68	14C17	2	Elbow, 45° - 1/4" N.P.T.F. x 3/8" T.
69	11M91	2	Terminal Bolt
70	CL-80-482W	2	Hose, 3/8" I.D. x 186"
71	23C20	2	Elbow, 90° - 1/4" N.P.T.F. x 3/8" T.
73	20K38	3	Clamp

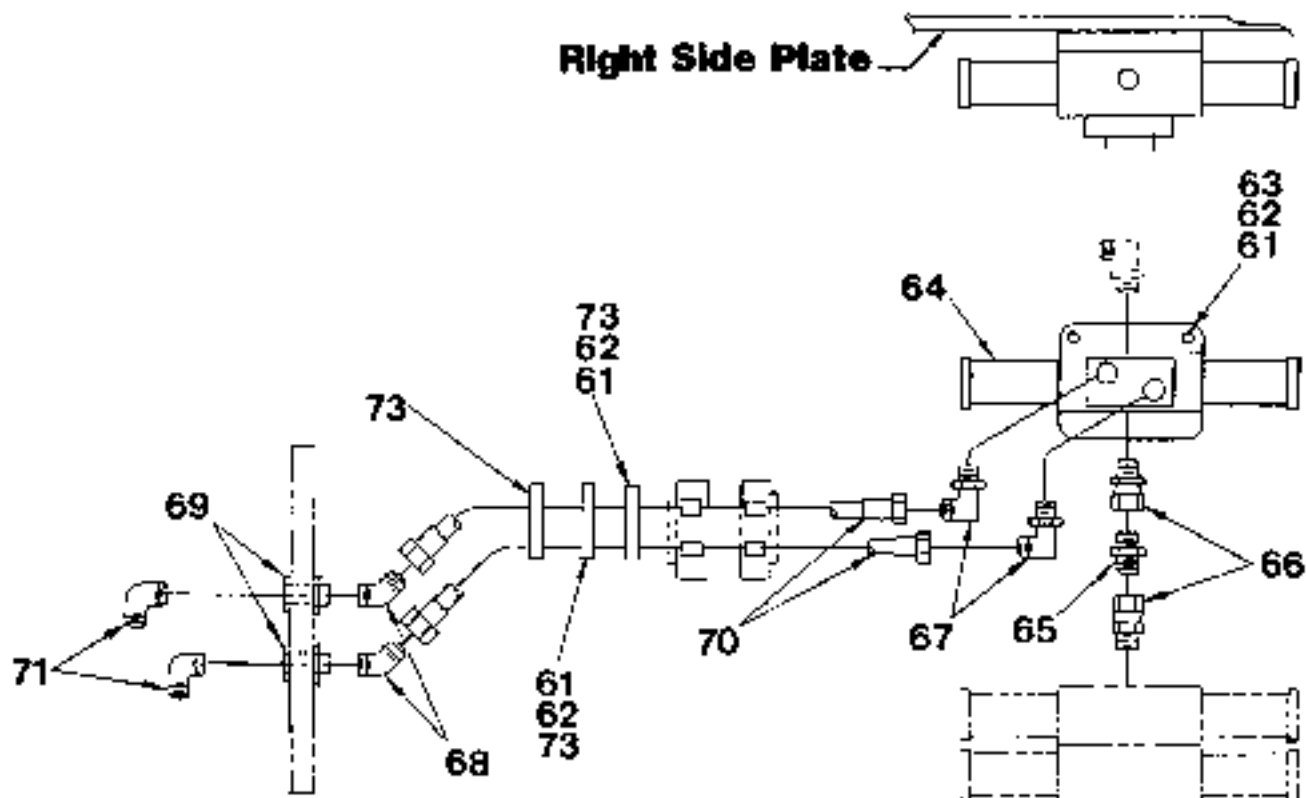

LAYTON TRUCK HITCH COMPONENTS

B2-276-5240B

(Before Ordering, Consult Table of Contents to Verify Proper Bill of Material Number.)

REF.	PART NUMBER	QTY.	DESCRIPTION
	20P55	2	Switch (Located on Operators Station)
61	13J31	3	1/4" x 3/4" Hex Head Cap Screw
62	27L76	3	1/4" Lock Washer
63	27L52	2	1/4" Cut Washer
64	26N60	1	Valve, Solenoid (See Section 12 For Breakdown)
65	23C86	1	Nipple, 1/2" N.P.T.F.
66	23K89	2	Connector, 1/2" N.P.S.M. x 3/4"-16 Str.
67	14I 07	2	Elbow, 90° - 3/8" T. x 3/4"-16 Str.
68	14C17	2	Elbow, 45° - 1/4" N.P.T.F. x 3/8" T.
69	11M91	2	Terminal Bolt
70	CL-80-482W	2	Hose, 3/8" I.D. x 186"
71	13R85	2	Elbow, 90° - 1/4" N.P.T.F. x 5/16" T.
73	20K38	3	Clamp

5/1/90 (1-7) (1-9)

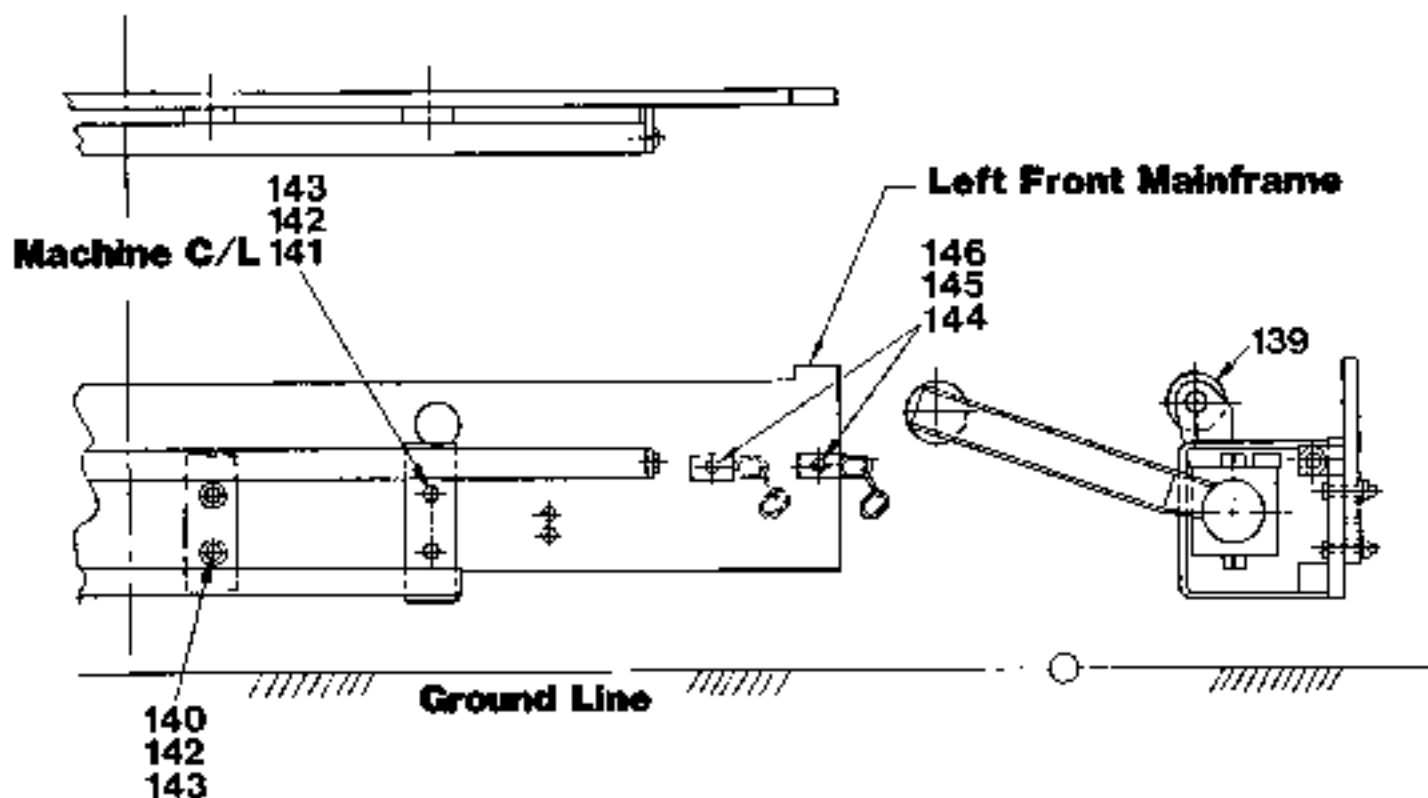

LAYTON TRUCK HITCH

E-876-5240B

(Before Ordering, Consult Table of Contents to Verify Proper Bill of Material Number.)

REF.	PART NUMBER	QTY.	DESCRIPTION
139	29E85	1	Hitch, Truck (See Separate Manual)
140	13V91	4	3/4" X 3.25" Hex Head Cap Screw
141	13V88	4	3/4" x 3" Hex Head Cap Screw
142	27L87	8	3/4" Lock Washer
143	27D01	8	3/4" Hex Nut
144	12T10	2	5/8" x 2.75" Hex Head Cap Screw
145	27L84	2	5/8" Lock Washer
146	27C98	2	5/8" Hex Nut

5/1/90 (1-7) (1-9)

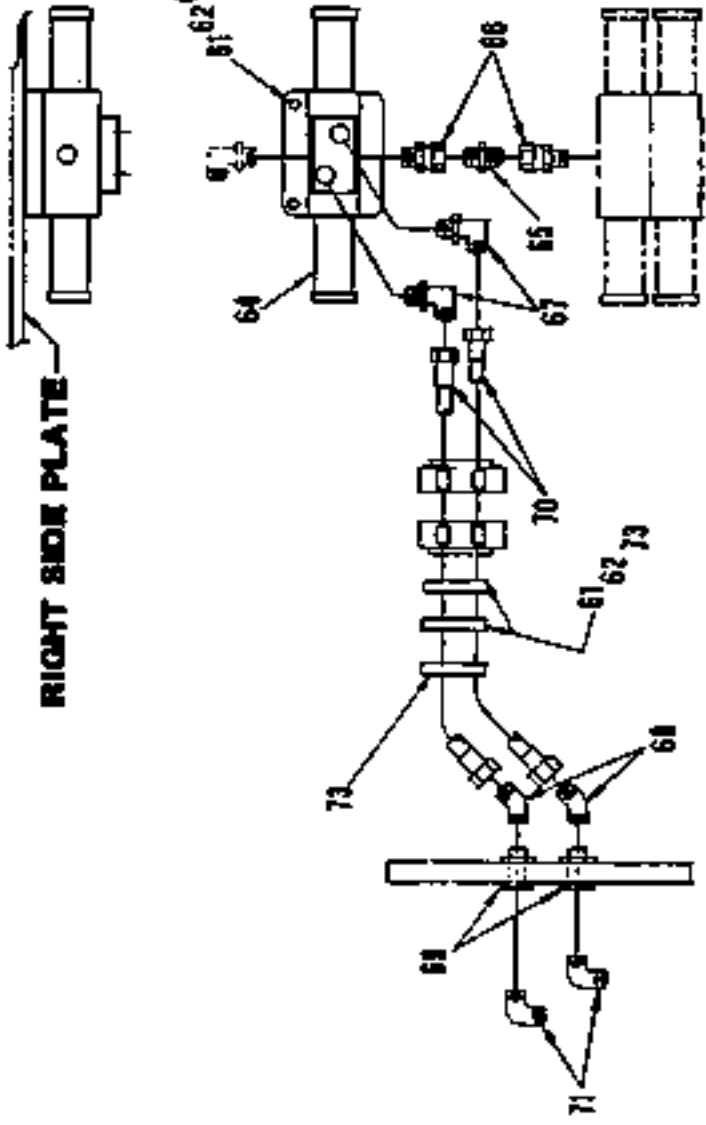

ALLATT TRUCK HITCH
 (With Hydraulics & Electrical)
 CB-876-52/0B

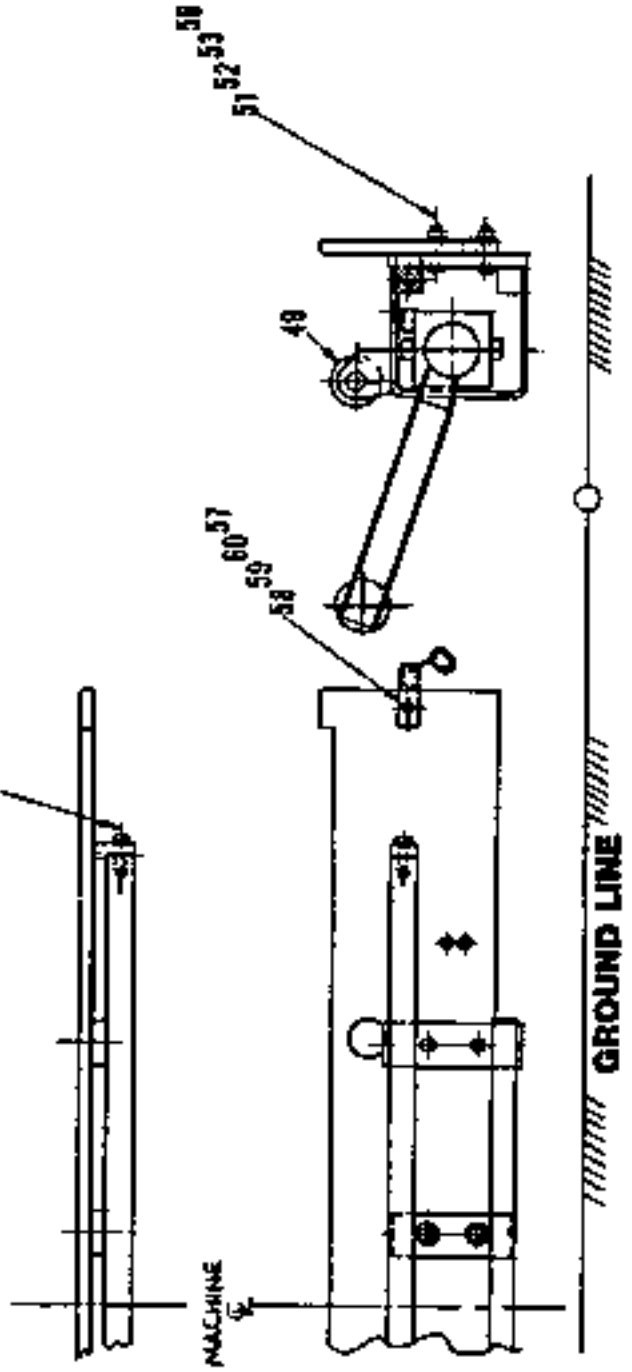

**ALLATT TRUCK HITCH
(With Hydraulics & Electrical)**

CB-876-5240B

(Before Ordering, Consult Table of Contents to Verify Proper Bill of Material Number.)

REF.	PART NUMBER	QTY.	DESCRIPTION
Ref. #49 thru #73 Symbolized by NONE on illustration.			
49	a 28R94	1	Hitch, Truck
	20P55	2	Switch (Located on Operators Station)
51	13V88	8	3/4" x 3" Hex Head Cap Screw
52	27D01	8	3/4" Hex Nut
53	27L60	8	3/4" Cut Washer
54	15S88	2	3/4" x 1.75" Hex Head Cap Screw
55	CA-876-5243	2	Block, Bumper
56	27L97	10	3/4" Lock Washer
57	27L59	8	5/8" Cut Washer
58	12T10	4	5/8" x 2.75" Hex Head Cap Screw
59	27C98	4	5/8" Hex Nut
60	27L84	4	5/8" Lock Washer
61	13J31	3	1/4" x 3/4" Hex Head Cap Screw
62	27L76	3	1/4" Lock Washer
63	27L52	2	1/4" Cut Washer
64	26N60	1	Valve, Solenoid (See Section 12 For Breakdown)
65	23C86	1	Nipple, 1/2" N.P.T.F.
66	23K89	2	Connector, 1/2" N.P.S.M. x 3/4"-16 Str.
67	14L07	2	Elbow, 90° - 3/8" T. x 3/4"-16 Str.
68	14C17	2	Elbow, 45° - 1/4" N.P.T.F. x 3/8" T.
69	11M91	2	Terminal Galt
70	CL-80-4A2W	2	Hose, 3/8" I.D. x 186"
71	13R85	2	Elbow, 90° - 1/4" N.P.T.F. x 5/16" T.
73	20K38	3	Clamp

a - Consult Barber-Greene Repair Parts Department for repairs on this item.

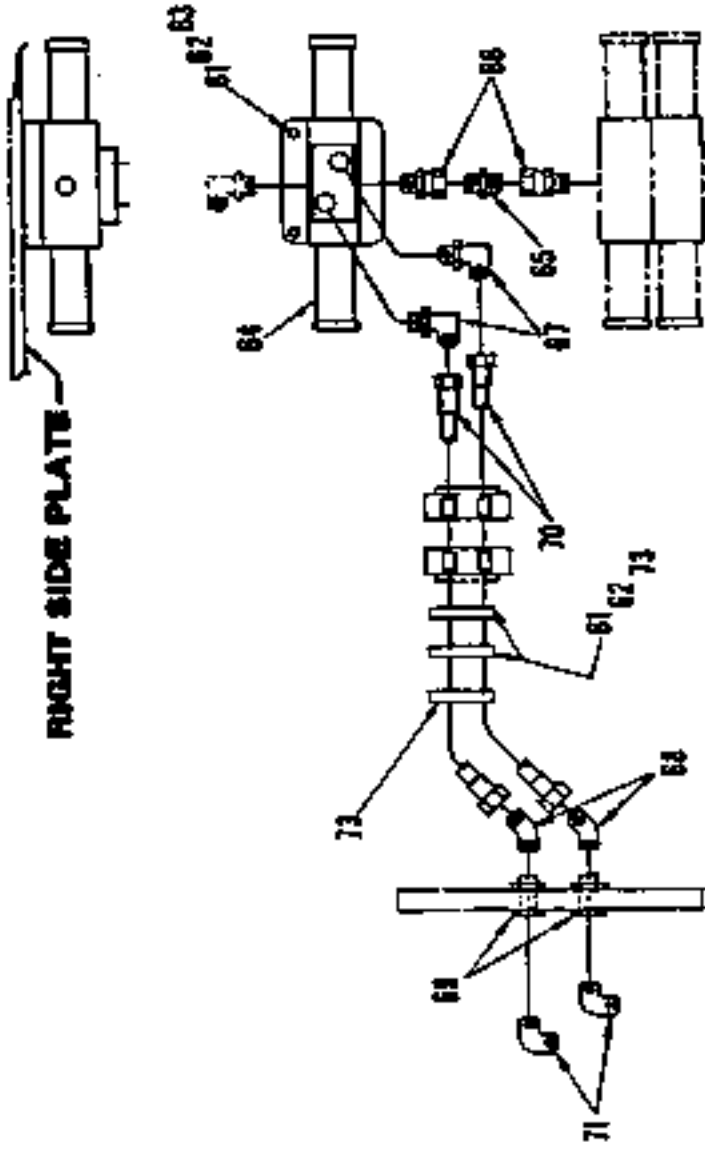

ROADTEC TRUCK HITCH
(With Hydraulics & Electrical)
CBI-876-5240R

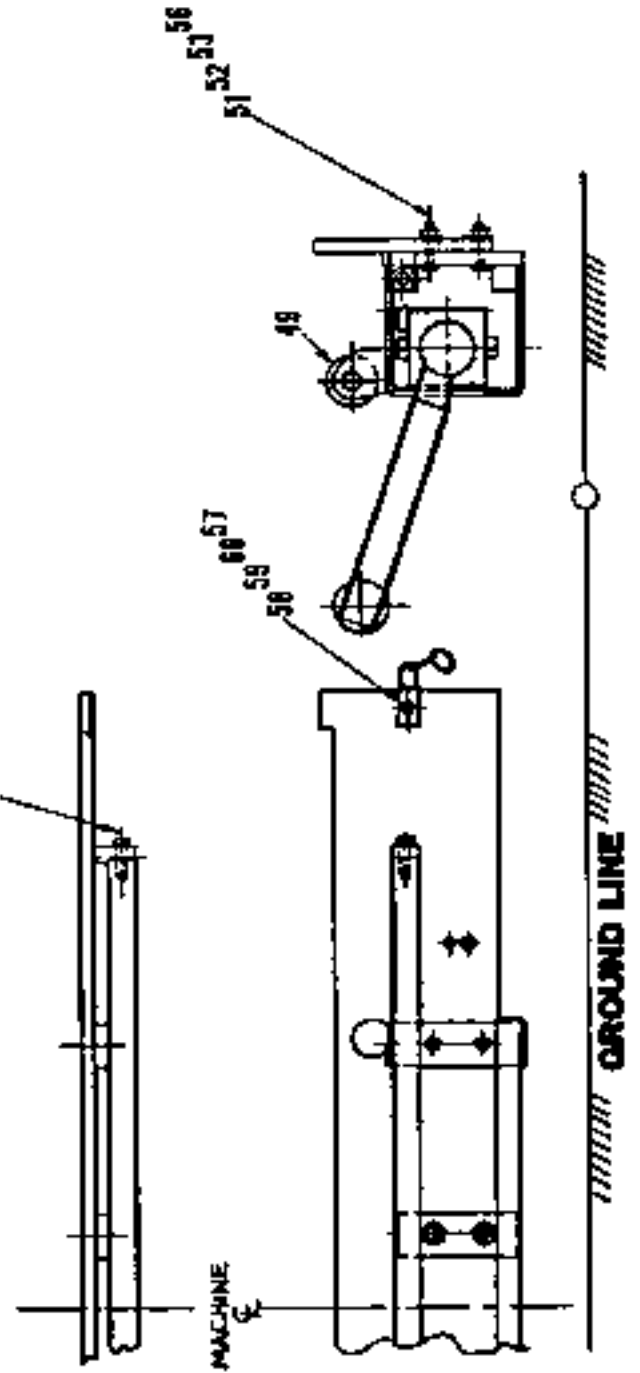

**ROADTEC TRUCK HITCH
(With Hydraulics & Electrical)**

CBI-876-52408

(Before Ordering, Consult Table of Contents to Verify Proper Bill of Material Number.)

REF.	PART NUMBER	QTY.	DESCRIPTION
Ref. #49 thru #73 Symbolized by NONE on Illustration.			
49 a	RTP-84677-02	1	Hitch, Truck (Roadtec)
	20P55	2	Switch (Located on Operators Station)
51	11V44	8	3/4" x 4-1/2" Socket Head Cap Screw
52	27D01	8	3/4" Hex Nut
53	27L60	8	3/4" Cut Washer
54	15S88	2	3/4" x 1.75" Hex Head Cap Screw
55	CA-876-5243	2	Block, Bumper
56	27L87	10	3/4" Lock Washer
57	27L59	8	5/8" Cut Washer
58	12T10	4	5/8" x 2.75" Hex Head Cap Screw
59	27C98	4	5/8" Hex Nut
60	27L84	4	5/8" Lock Washer
61	13J31	3	1/4" x 3/4" Hex Head Cap Screw
62	27L76	3	1/4" Lock Washer
63	27L52	2	1/4" Cut Washer
64	26N60	1	Valve, Solenoid (See Section 12 For Breakdown)
65	23C86	1	Nipple, 1/2" N.P.T.F.
66	23K89	2	Connector, 1/2" N.P.S.M. x 3/4"-16 Str.
67	14L07	2	Elbow, 90° - 3/8" T. x 3/4"-16 Str.
68	14C17	2	Elbow, 45° - 1/4" N.P.T.F. x 3/8" T.
69	11M91	2	Terminal Bolt
70	CL-80-482W	2	Hose, 3/8" I.D. x 186"
71	23C20	2	Elbow, 90° - 1/4" N.P.T.F. x 3/8" T.
73	20K38	3	Clamp
	DF-80-482W	2	Hose, 3/8" I.D. x 54"
	11A54	2	Chain, 5/16" x 24"
	31A14	2	Ring, Retaining - .693" I.D.

a - Consult Barber-Greene Repair Parts Department for repairs on this item.

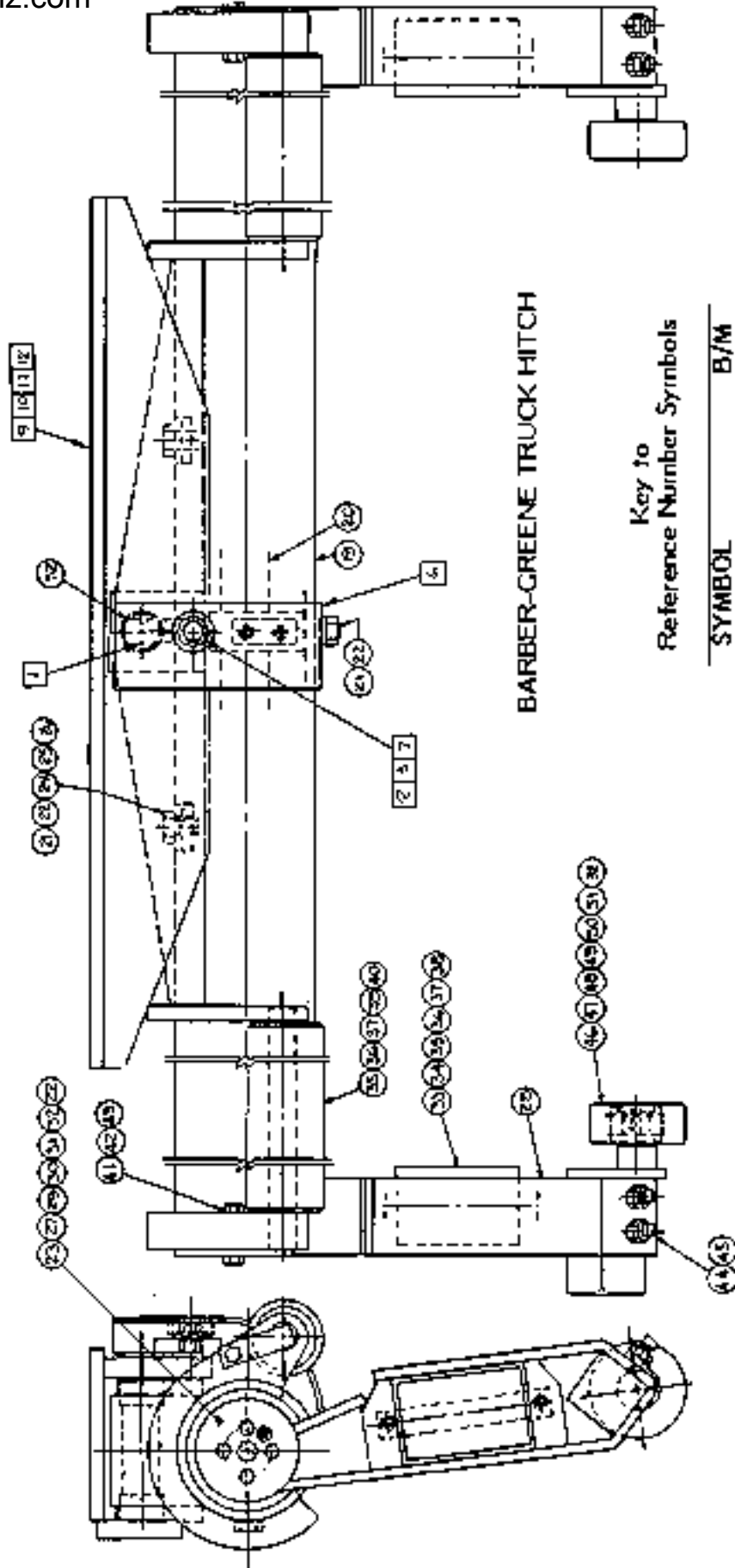

BARBER-GREENE TRUCK HITCH

F-876-5240B

(Before Ordering, Consult Table of Contents to Verify Proper Bill of Material Number.)

REF.	PART NUMBER	QTY.	DESCRIPTION
------	-------------	------	-------------

Ref. #1 thru #12 Symbolized by  on Illustration.

1	EC-876-5242W	1	Pin, Pivot
2	26C50	1	5/8" x 2" Hex Head Cap Screw
3	27C98	1	5/8" Hex Nut
6	HB-876-5242W	1	Guard, Hose
7	HG-876-5243	2	Washer
9	HC-876-5242W	1	Support
10	13V88	8	3/4" x 3" Hex Head Cap Screw
11	26A41	8	3/4" Lock Nut
12	27L60	8	3/4" Cut Washer

Ref. #19 thru #52 Symbolized by  on Illustration.

	F-876-5240A	1	Truck Hitch Assembly (Consisting of the following indented items):
19	GA-876-5242W	1	. Housing, Hitch
20	20P20	1	. Cylinder, Hydraulic
21	12K31	4	. 3/4" x 1-3/4" Hex Head Cap Screw (Grade 8)
22	27L87	6	. 3/4" Lock Washer
23	EA-876-5242W	2	. Tube, Extension
24	FD-876-5243	2	. Roller
25	FE-876-5243	2	. Spacer
26	26B48	2	. 3/4" Hardened Cut Washer
27	EC-876-5243	2	. Cap, End
28	DB-876-5242W	2	. Arm, Rim
29	26E28	8	. 1/2" x 1-1/4" Hex Head Cap Screw
30	27L81	8	. 1/2" Lock Washer
31	27D01	2	. 3/4" Hex Nut
32	23C60	4	. Fitting, Lube - 1/8" N.P.T.
33	DG-876-5243	2	. Shaft, Roller
34	DH-876-5243	2	. Roller, Tire
35	12S34	8	. Bearing
36	CR-17-478	8	. Washer
37	CS-17-478	8	. Washer
38	26C54	4	. 1/2" x 2-1/4" Hex Head Cap Screw
39	AA-876-5243	2	. Roller
40	EB-876-5242W	2	. Shaft, Roller
41	13J41	2	. 5/8" x 3" Hex Head Cap Screw
42	27L84	2	. 5/8" Lock Washer
43	27C98	2	. 5/8" Hex Nut
44	27K44	4	. 1/2" x 1-3/4" Socket Head Set Screw
45	27C95	4	. 1/2" Hex Nut
46	DA-876-5242W	2	. Support, Roller
47	EA-876-5243	2	. Roller, Rim

REF.	PART NUMBER	QTY.	DESCRIPTION
48	EB-876-5243	2	. Retainer, Roller
49	50L87	2	. Bearing
50	12S33	2	. Ring, Snap
51	12T09	2	. 1/2" x 1" Socket Flat Head Cap Screw
52	29R24	2	. Bearing
	HA-876-5242W	2	. Cover, Roller
	27L58	8	. 1/2" Cut Washer
	26A39	8	. 1/2" Lock Nut

o - Consult Barber-Greene Repair Parts Department for repairs on this item.

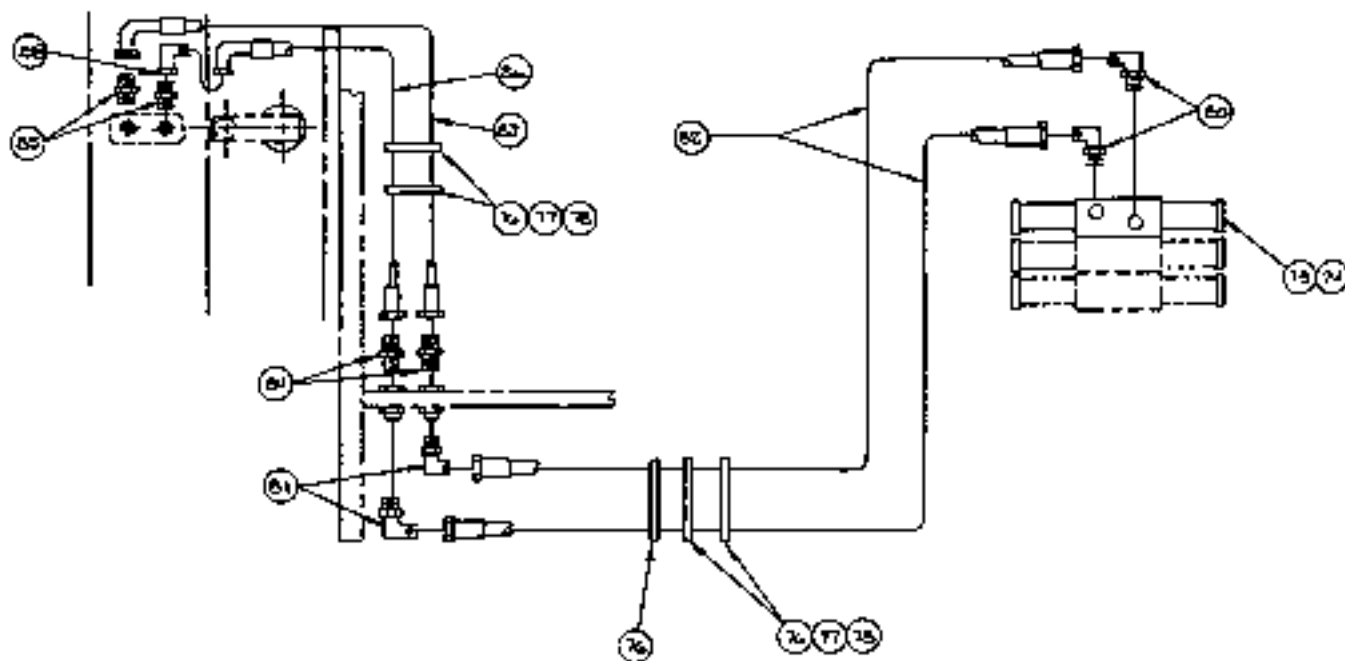

BARBER-GREENE TRUCK HITCH COMPONENTS

G-876-5240B

(Before Ordering, Consult Table of Contents to Verify Proper Bill of Material Number.)

REF.	PART NUMBER	QTY.	DESCRIPTION
	20P55	2	Switch (Located on Operators Station)
73	29R86	1	Valve
74	29R78	1	Kit, Stacking (3 Valve)
76	20K38	5	Clamp
77	13J31	4	1/4" x 3/4" Hex Head Cap Screw
78	27L76	4	1/4" Lock Washer
80	14L07	2	Elbow, 90° - 3/8" T. x 3/4" Str.
81	23C20	2	Elbow, 90° - 3/8" T. x 1/4" P.
82	CL-80-482W	2	Hose Assembly, Hydraulic - 3/8" I.D. x 136"
84	23A06	2	Connector, 3/8" T. x 1/4" P.
85	23R04	2	Connector, 3/8" T. x 3/4" St.
86	BW-80-491W	1	Hose Assembly, Hydraulic - 3/8" I.D. x 39"
87	GL-80-491W	1	Hose Assembly, Hydraulic - 3/8" I.D. x 42"
88	26J03	1	Elbow, 90° - 3/8" T. Swivel

10/29/91 (3-2) (4-4)

TRUCK HITCH
103-A353

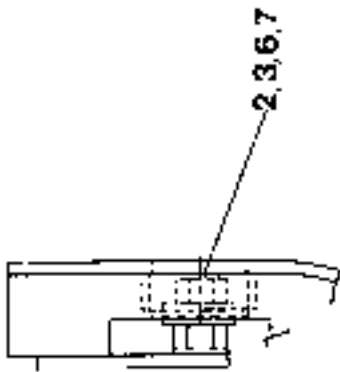

SCALE

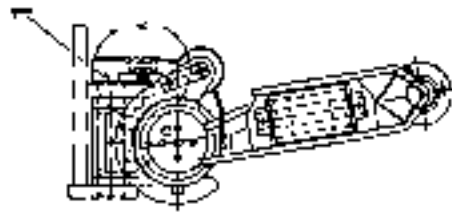
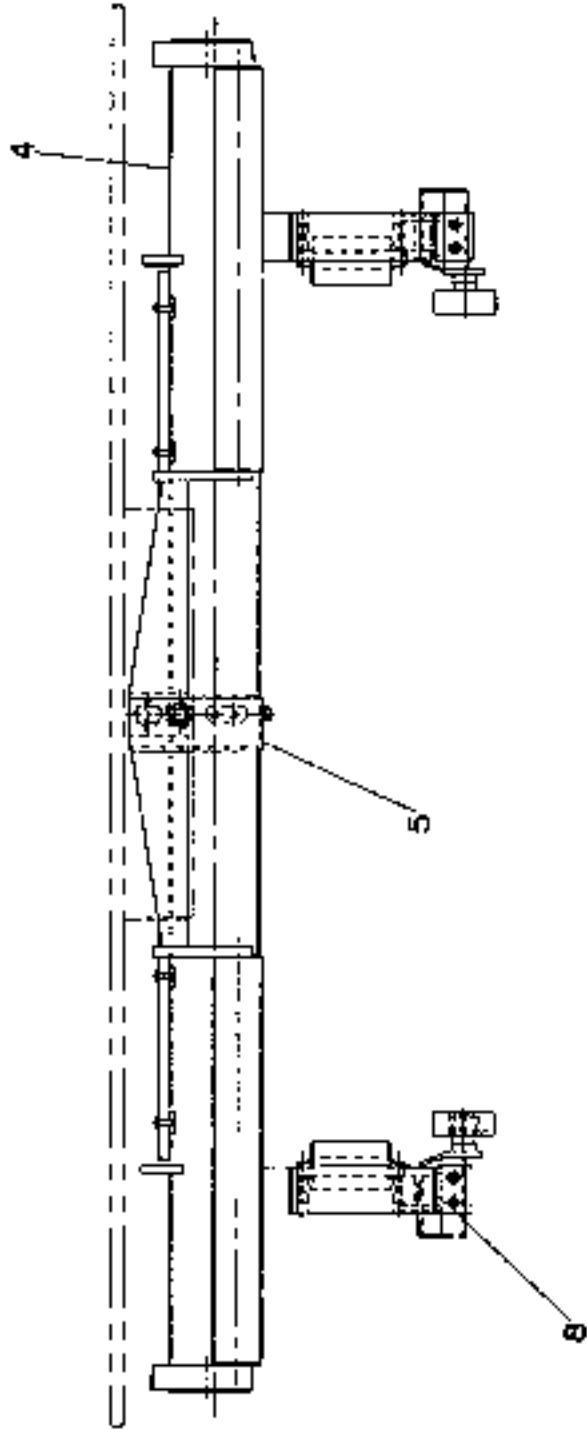

TRUCK HITCH

103-4353

(Before Ordering, Consult Table of Contents to Verify Proper Bill of Material Number.)

REF.	PART NUMBER	QTY.	DESCRIPTION
------	-------------	------	-------------

Ref. #1 thru #8 Symbolized by NONE on Illustration.

1	810567	1	Pin, Pivot
2	7X0346	1	Bolt
3	7X0448	1	Nut, Full
4	103-4354	1	Truck Hitch Assembly (See Section 3 Page 19)
5	810571	1	Guard
6	810391	2	Washer
7	AT4994	1	Washer, Hard
8	810724	2	Decal

TRUCK HITCH ASSEMBLY
103-4354

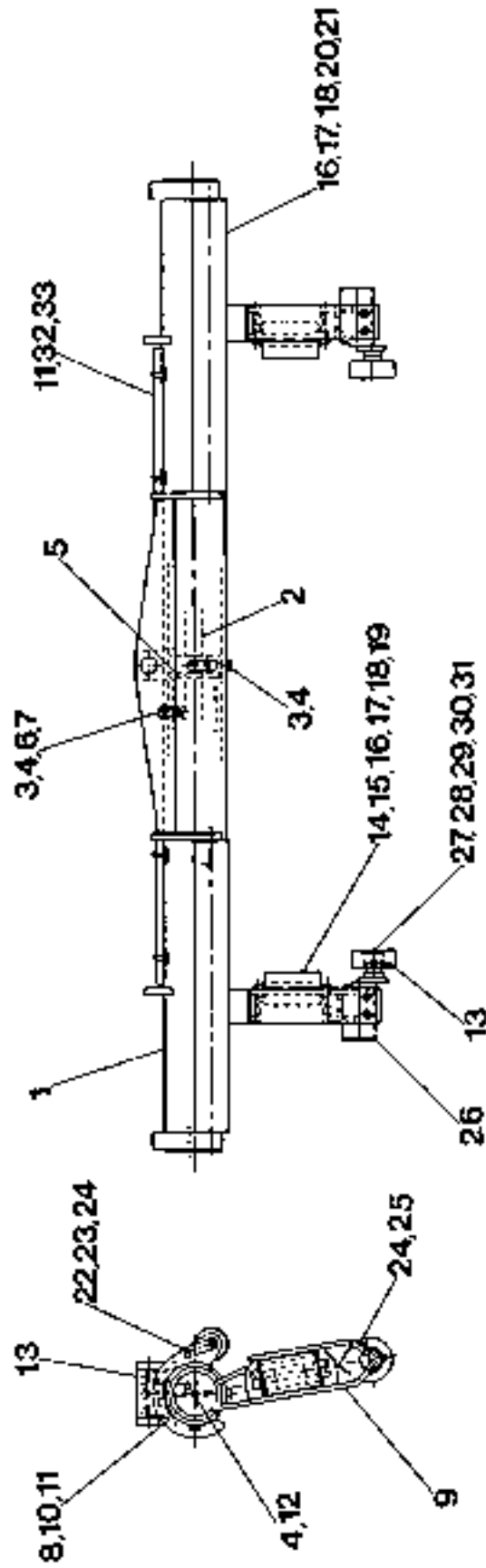

TRUCK HITCH ASSEMBLY

103-4354

(From Section 3 Page 17)

(Before Ordering, Consult Table of Contents to Verify Proper Bill of Material Number.)

REF.	PART NUMBER	QTY.	DESCRIPTION
Ref. #1 thru #33 Symbolized by NONE on Illustration.			
1	810640	1	Housing, Hitch
2	^a 810628	1	Cylinder, Hydraulic
3	8T9398	4	Bolt
4	8T4994	6	Washer, Hard
5	810565	2	Tube, Extension
6	810381	2	Roller, Guide
7	810382	2	Spacer
8	810373	2	Plate
9	810564	2	Arm, Rim
10	8T8917	8	Bolt
11	8T4223	16	Washer, Hard
12	6V8182	2	Nut, Full
13	3B8489	4	Fitting, Hydraulic
14	810578	2	Shaft, Side Roller
15	810579	2	Roller, Side
16	619487	8	Bearing
17	810625	8	Washer
18	810626	8	Washer
19	5P2424	4	Bolt
20	810627	2	Roller
21	810566	2	Shaft, Roller
22	7X0349	2	Bolt
23	8T4122	2	Washer, Hard
24	7X0448	6	Nut, Full
25	4B3596	4	Setscrew
26	810563	2	Support, Roller
27	810371	2	Roller, Rim
28	810372	2	Washer
29	4D0298	2	Bearing
30	052-0512	2	Ring, Snap
31	4K1493	2	Screw, Hollow
32	810570	2	Cover, Roller
33	1K6872	8	Locknut

^a - Consult Barber-Greene Repair Parts Department for repairs on this item.

SECTION 4

BG-220B Asphalt Paver

HOPPER, APRONS & FLASHING

HOPPERS & APRONS
A1-876-5235B

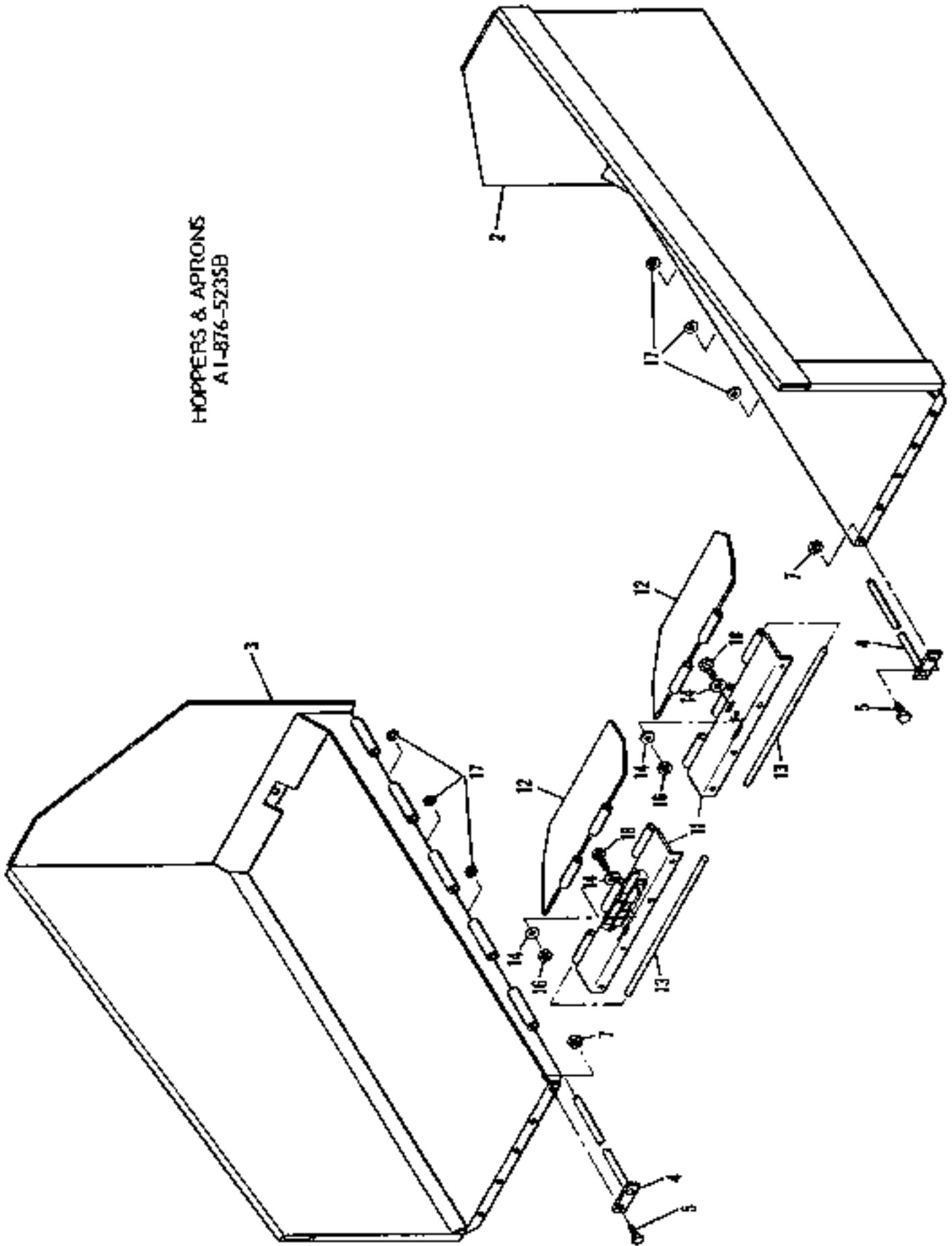

2/25/89

HOPPERS & APRONS

AI-876-5235B

(Before Ordering, Consult Table of Contents to Verify Proper Bill of Material Number.)

REF.	PART NUMBER	QTY.	DESCRIPTION
Ref. #2 thru #18 Symbolized by NONE on Illustration.			
2	AI-876-5237W	1	Hopper (Left Side)
3	AAI-876-5237W	1	Hopper (Right Side)
4	BA-876-5237W	2	Pin, Hopper Hinge
5	26C53	2	3/8" x 1" Hex Head Cap Screw
7	26A37	2	3/8" Lock Nut
11	CA-876-5237W	2	Support, Apron
12	CB-876-5237W	2	Apron
13	FC-876-5238	2	Pin, Apron Hinge
14	27L59	4	5/8" Cu1 Washer
	11N68	2 a	5/8" x 2-1/2" Hex Head Cap Screw (Full Thread)
16	27C98	4 a	5/8" Hex Nut
17	CE-876-4648	6	Spacer, Hinge
18	27A65	2	5/8" x 2.50" Carriage Bolt

a - Two bolts and nuts are required for the Rear Hopper Support Stop.

HOPPERS & APRONS
A2-876-5235B

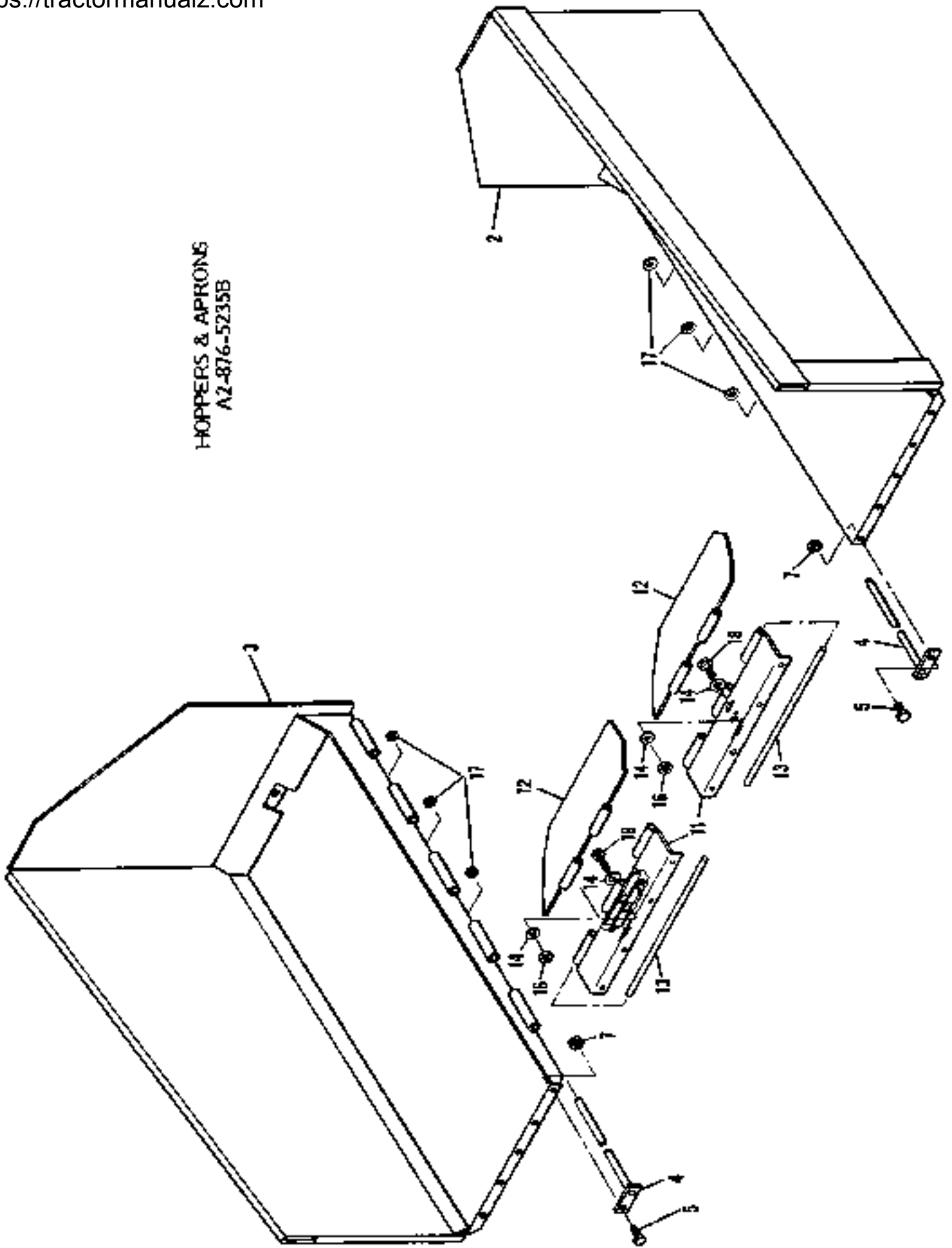

2/25/89

HOPPERS & APRONS

A2-876-5235B

(Before Ordering, Consult Table of Contents to Verify Proper Bill of Material Number.)

REF.	PART NUMBER	QTY.	DESCRIPTION
Ref. #2 thru #18 Symbolized by NONE on Illustration.			
2	A2-876-5237W	1	Hopper (Left Side)
3	AA2-876-5237W	1	Hopper (Right Side)
4	BA-876-5237W	2	Pin, Hopper Hinge
5	26C53	2	3/8" x 1" Hex Head Cap Screw
7	26A37	2	3/8" Lock Nut
11	CA-876-5237W	2	Support, Apron
12	CB-876-5237W	2	Apron
13	FC-876-5238	2	Pin, Apron Hinge
14	27L59	4	5/8" Cut Washer
	11N68	2 a	5/8" x 2-1/2" Hex Head Cap Screw (Full Thread)
16	27C98	4 a	5/8" Hex Nut
17	CE-876-4648	6	Spacer, Hinge
18	27A65	2	5/8" x 2.50" Carriage Bolt

a - Two bolts and nuts are required for the Rear Hopper Support Stop.

HOPPERS & APRONS
CA-876-5235B

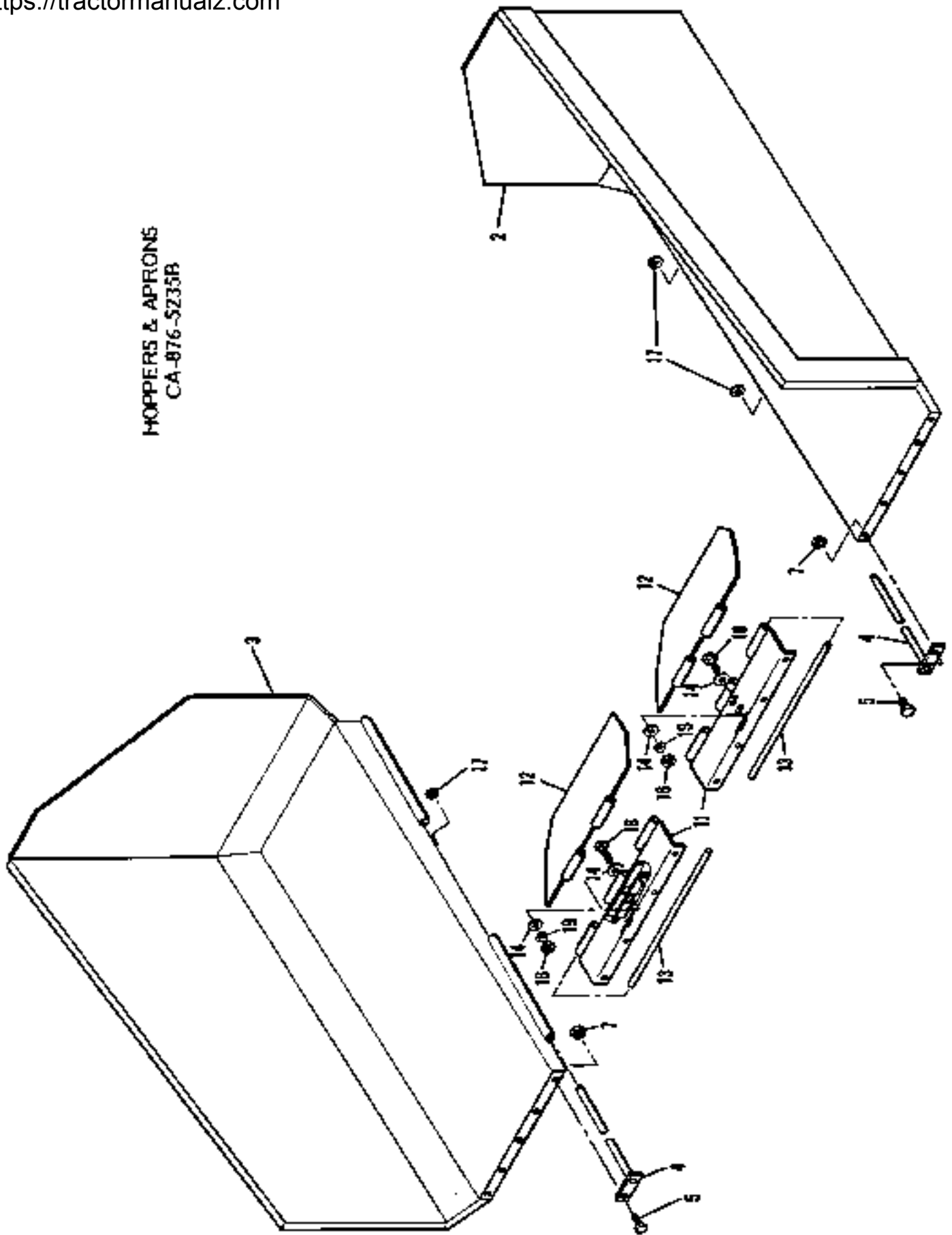

HOPPERS & APRONS

CA-876-5235B

(Before Ordering, Consult Table of Contents to Verify Proper Bill of Material Number.)

REF.	PART NUMBER	QTY.	DESCRIPTION
Ref. #2 thru #19 Symbolized by NONE on Illustration.			
2	MA-876-5237WL	1	Hopper (Left Side)
3	MA-876-5237WR	1	Hopper (Right Side)
4	BA-876-5237W	2	Pin, Hopper Hinge
5	26C53	2	3/8" x 1" Hex Head Cap Screw
7	26A37	2	3/8" Lock Nut
11	CA-876-5237W	2	Support, Apron
12	CB-876-5237W	2	Apron
13	FC-876-5238	2	Pin, Apron Hinge
14	27L59	4	5/8" Cut Washer
	11N68	2 a	5/8" x 2-1/2" Hex Head Cap Screw (Full Thread)
16	27C9B	4 a	5/8" Hex Nut
17	CE-876-4648	6	Spacer, Hinge
18	27A65	2	5/8" x 2.50" Carriage Bolt
19	27L84	2	5/8" Lock Washer

a - Two bolts and nuts are required for the Rear Hopper Support Stop.

STANDARD HOPPER FLASHING
B-876-5235B

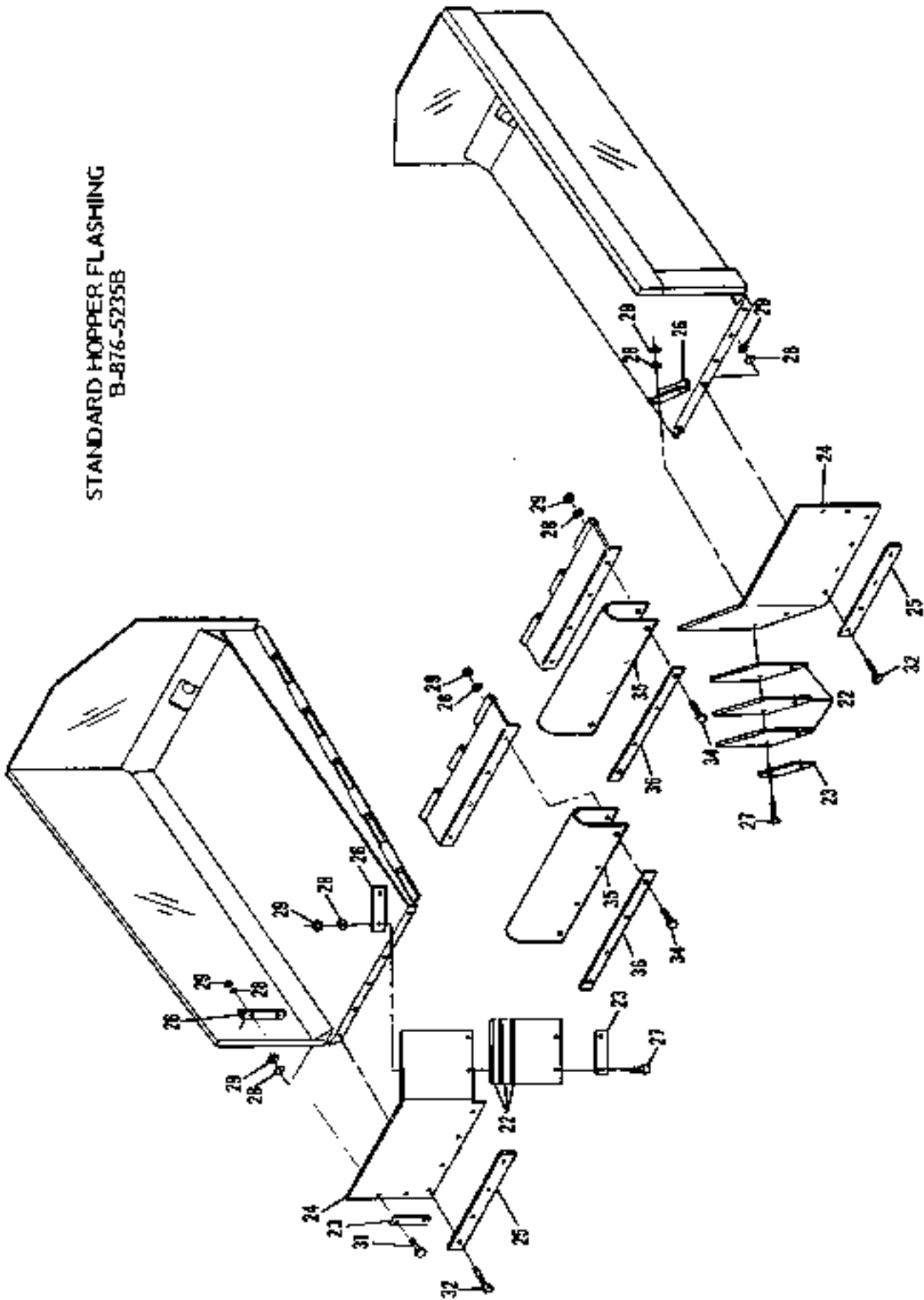

STANDARD HOPPER FLASHING

B-876-5235B

(Before Ordering, Consult Table of Contents to Verify Proper Bill of Material Number.)

REF.	PART NUMBER	QTY.	DESCRIPTION
Ref. #22 thru #36 Symbolized by NONE on Illustration.			
22	EC-876-175B	6	Retainer, Belt
23	EG-876-175B	4	Bar
24	GA-876-5238	2	Flashing, Hopper
25	JC-876-5238	2	Bar
26	EF-876-175B	4	Angle
27	13J47	4	3/8" x 2-1/2" Hex Head Cap Screw
28	27L78	24	3/8" Lock Washer
29	27C9D	24	3/8" Nuts
31	10E10	4	3/8" x 1-1/4" Hex Head Cap Screw
32	10V14	8	3/8" x 1-1/2" Hex Head Cap Screw
34	13M81	8	3/8" x 1-3/4" Hex Head Cap Screw
35	JA-876-5238	2	Flashing, Apron
36	JB-876-5238	2	Bar

DELUXE HOPPER FLASHING
C-876-5235B

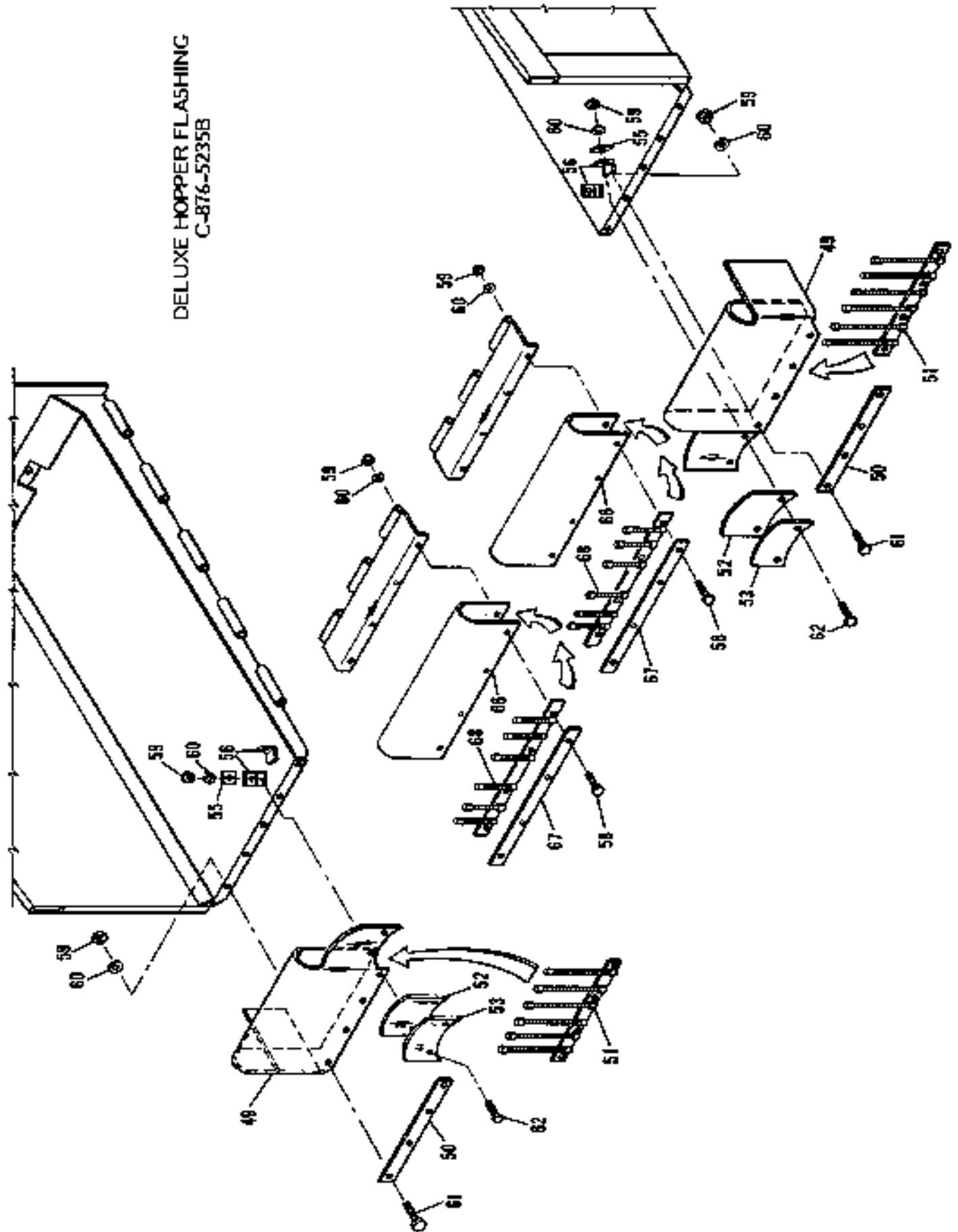

DELUXE HOPPER FLASHING

C-876-5235B

(Before Ordering, Consult Table of Contents to Verify Proper Bill of Material Number.)

REF.	PART NUMBER	QTY.	DESCRIPTION
Ref. #49 thru #68 Symbolized by NONE on Illustration.			
49	HA-876-5238	2	Flashing, Rubber
50	JC-876-5238	2	Plate, Bolt
51	DA-876-5237W	2	Support, Flashing
52	BB-876-5093	2	Retainer
53	BC-876-5093	2	Retainer
55	BG-876-4648	4	Bar, Clamp
56	BH-876-4648	4	Angle
58	12D39	8	3/8" x 2-3/4" Hex Head Cap Screw
59	27C90	20	3/8" Nut
60	27L78	20	3/8" Lock Washer
61	23X30	8	3/8" x 3" Hex Head Cap Screw
62	11N32	4	3/8" x 2" Hex Head Cap Screw
66	JA-876-5238	2	Flashing, Rubber
67	JB-876-5238	2	Plate, Bolt
68	DB-876-5237W	2	Support, Flashing

SECTION 5

BG-220B Asphalt Paver

FEEDER COMPONENTS

FEEDER GATES
AI-876-5245B

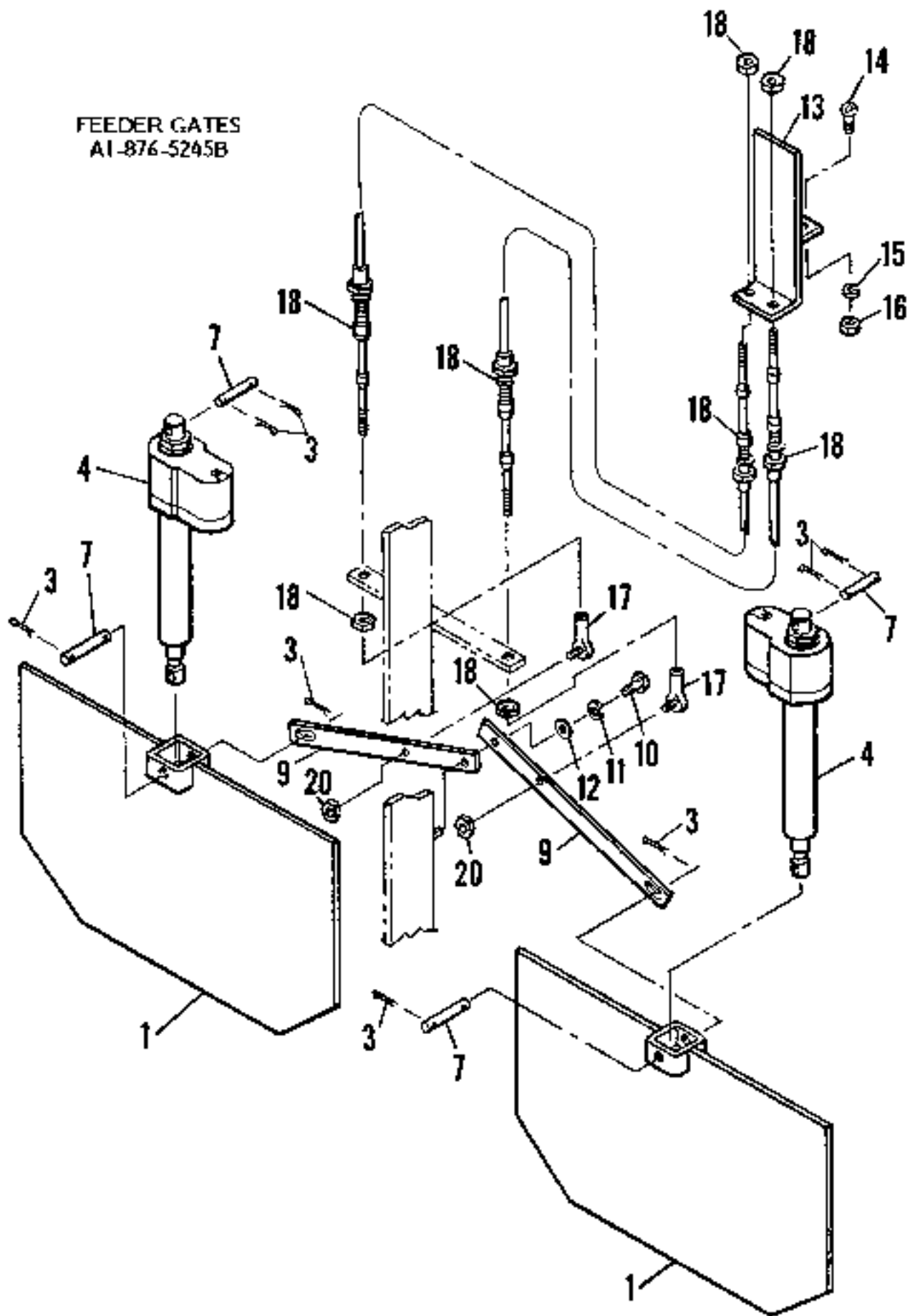

FEEDER GATES

AI-876-5245B

(Before Ordering, Consult Table of Contents to Verify Proper Bill of Material Number.)

REF.	PART NUMBER	QTY.	DESCRIPTION
Ref. #1 thru #20 Symbolized by NONE on Illustration.			
1	WB-876-5247W	2	Gate, Feeder
3	27D53	8	Pin, Cotter - 1/8" x 1"
4 ^a	2BW04	2	Actuator, Gate
7	XO-17-25	4	Pin, Clevis
9	GE-876-5249	2	Link
10	13J28	1	1/4" x .50" Hex Head Cap Screw
11	27L76	1	1/4" Lock Washer
12	27L52	1	1/4" Cot Washer
13	WC-876-5247W	1	Support, Gauge
14	27J96	2	#10-24 x .50" Pan Head Machine Screw
15	27L99	2	#10 Lock Washer
16	27C79	2	#10 Hex Nut
17	28W35	2	End, Rod
18	28W38	2	Cable, Push / Pull
20	27C82	2	#10-32 Hex Nut

^a - Consult Barber-Greene Repair Parts Department for repairs on this item.

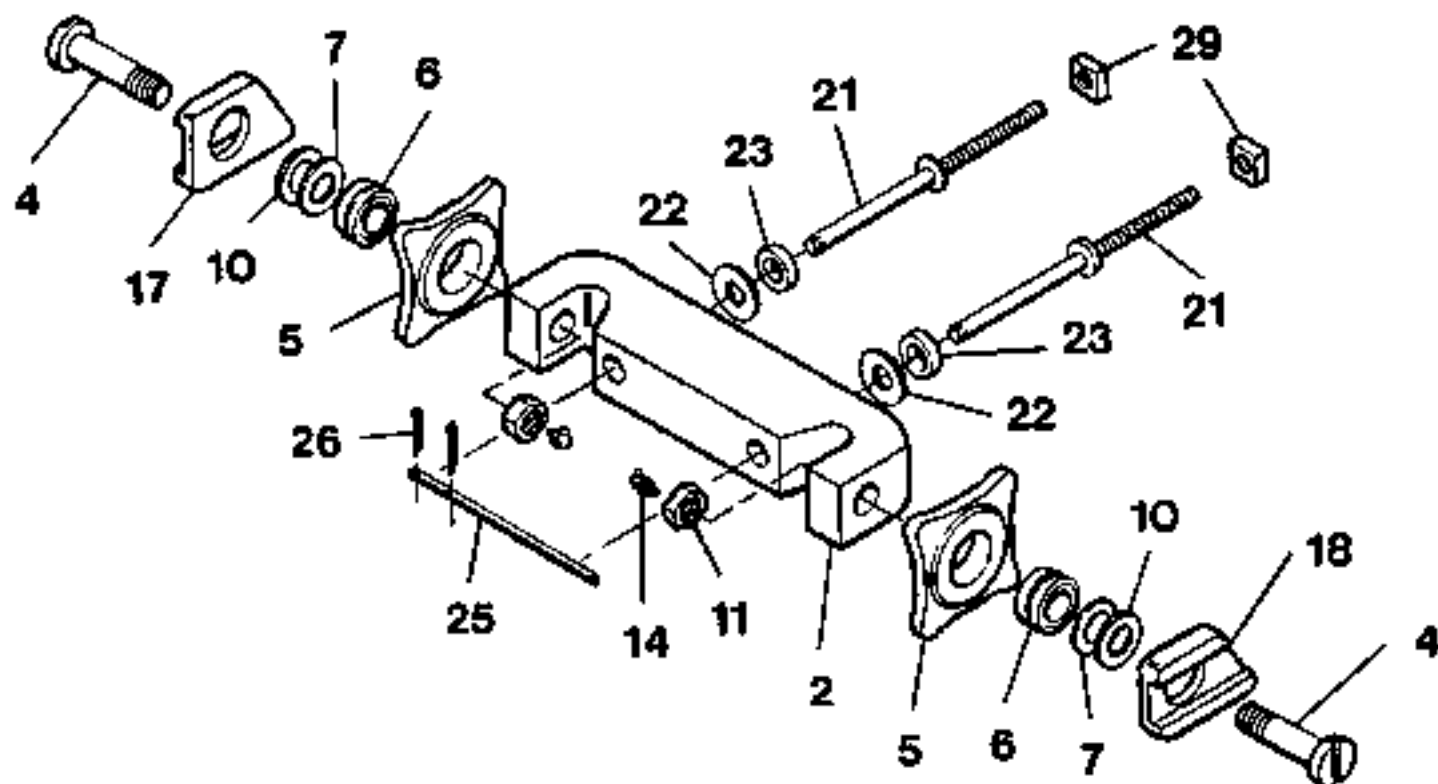

FEEDER FOOT SHAFT

T-876-5245B

(Before Ordering, Consult Table of Contents to Verify Proper Bill of Material Number.)

REF.	PART NUMBER	QTY.	DESCRIPTION
2	CA-876-5249	2	Guide, Support
4	AA-876-5249	4	Shaft
5	A-19-2483	4	Sprocket
6	30H54	4	Bearing Assembly
7	50R12	8	Ring, Nilas
10	RQ-17-9	12	Washer, 1-5/16" I.D. x 1/16" Thick (Use As Required)
11	E-14-748	4	1-1/4"-12 U.N.F. Hex Nut
14	23C66	4	Fitting, 1/8" x 90° Lube
17	DA-876-5249	2	Slide
18	DB-876-5249	2	Slide
21	BD-876-5247W	4	Screw, Adjusting
22	27L64	4	1-1/4" Cut Washer
23	L-3-988	4	Collar, 2-1/2" O.D. x 1-1/4" I.D. x 5/8" Thick
25	GF-876-5248	2	Rod, Adjusting
26	27D55	4	Pin, Cotter - 1/8" x 1-1/2"
29	16H52	4	1-1/4"-7 U.N.C. Heavy Square Nut

5/1/90 (7-0)

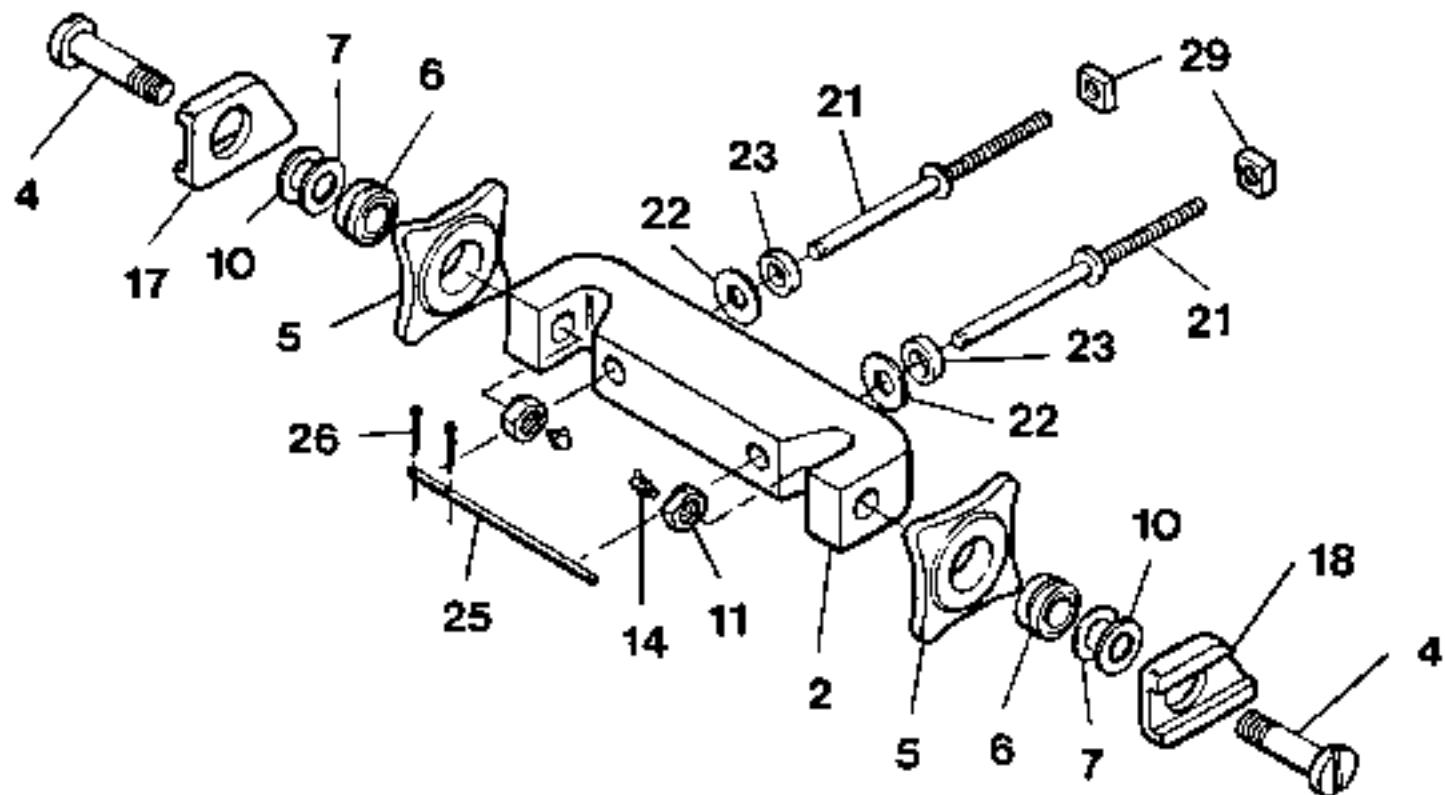

FEEDER FOOT SHAFT

TI-876-5245B

(Before Ordering, Consult Table of Contents to Verify Proper Bill of Material Number.)

REF.	PART NUMBER	QTY.	DESCRIPTION
2	CA-876-5249	2	Guide, Support
4	AA-876-5249	4	Shaft
5	A-19-2484	4	Sprocket
6	30H54	4	Bearing Assembly
7	50R12	8	Ring, Nilos
10	RQ-17-9	12	Washer, 1-5/16" I.D. x 1/16" Thick (Use As Required)
11	E-14-748	4	1-1/4"-12 U.N.F. Hex Nut
14	23C66	4	Fitting, 1/8" x 90° Lube
17	DA-876-5249	2	Slide
18	DB-876-5249	2	Slide
21	BD-876-5247W	4	Screw, Adjusting
22	27L64	4	1-1/4" Cut Washer
23	L-3-988	4	Collar, 2-1/2" O.D. x 1-1/4" I.D. x 5/8" Thick
25	GF-876-5248	2	Rod, Adjusting
26	27D55	4	Pin, Catter - 1/8" x 1-1/2"
29	16H52	4	1-1/4"-7 U.N.C. Heavy Square Nut

5/1/90 (7-1)

FEEDER FOOT SHAFT GREASE PIPING

V-876-5245B

(Before Ordering, Consult Table of Contents to Verify Proper Bill of Material Number.)

REF.	PART NUMBER	QTY.	DESCRIPTION
	23C59	4	Fitting, 1/8" N.P.T.F.
	26L14	4	Connector, 1/4" Ma. N.P.T. x 1/8" Ma. N.P.T.
	23M16	4	Connector, 1/4" Fe. N.P.T.F. x 1/4" Tube
	23H49	2	Elbow, 90° St. x 1/4" N.P.T.F.
	S-80-434W	4	Tube Assembly, 1/4" x 13'-8"
	11T75	4	Clamp
	26BB9	4	1/4" x 1/2" Self Tapping Round Head Cap Screw
	23L84	4	Elbow, 90° - 1/8" N.P.T. x 1/4" Tube
	29T76	2	Hose, Flexible Grease x 46"
	14P16	2	Hose, Flexible Grease x 36"
	23F07	4	Connector, 1/4" Tube x 1/8" N.P.T.F.

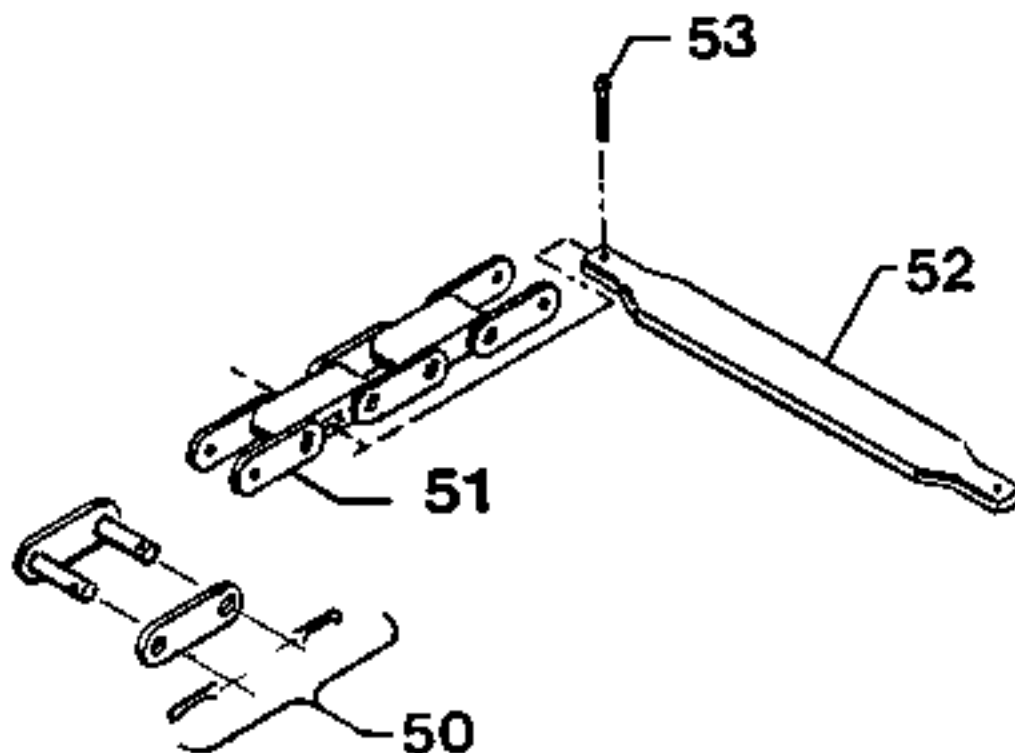

FEEDER FLIGHT CHAIN
(Standard Duty)

J2-876-5245B

(Before Ordering, Consult Table of Contents to Verify Proper Bill of Material Number.)

REF.	PART NUMBER	QTY.	DESCRIPTION
50	26596	4	Link, Connecting (Includes 2 Cotter Pins)
51 a	28K87	2	Feeder Flight Chain Assembly (Each Chain Assembly consists of two strands of chain. Each strand has 97 links.)
52	X-3-1085	48	Bar, Feeder Flight
53	28M89	96	Pin, Cotter - 1/4" x .75" ("T" Head)

a - For Connecting Link Order 26596. For Attachment Link Order 26597.

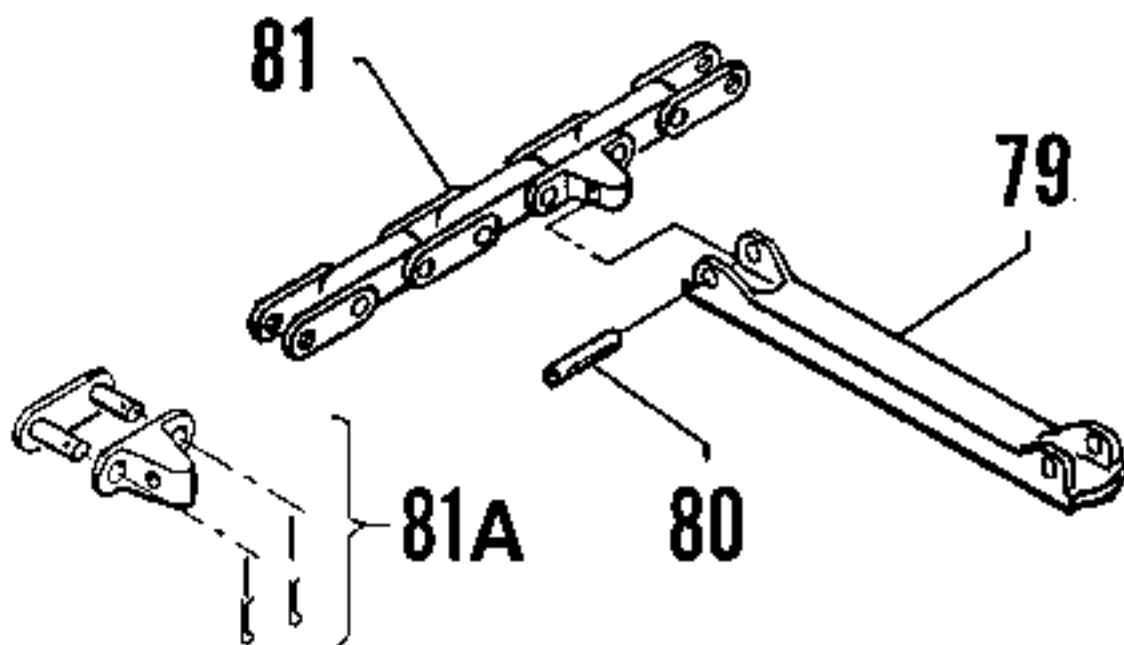

**FEEDER FLIGHT CHAIN
(Heavy Duty)**

K-876-5245B

(Before Ordering, Consult Table of Contents to Verify Proper Bill of Material Number.)

REF.	PART NUMBER	QTY.	DESCRIPTION
79	HB-876-5249	48	Bar, Feeder Flight
80	50B13	96	Pin, Spiral
81	29M44	2	Feeder Flight Chain Assembly (Each Chain Assembly consists of two strands of chain. Each strand has 98 links.)

Note: For Repair Purposes Order The Following Feeder Flight Chain Components As Required:

81A	14M42	a	Link, Attachment (With Pin)
	13M95	a	Link, Roller
	13M96	a	Link, Plain Connecting

a - Order As Required.

5/1/90 (2-11)

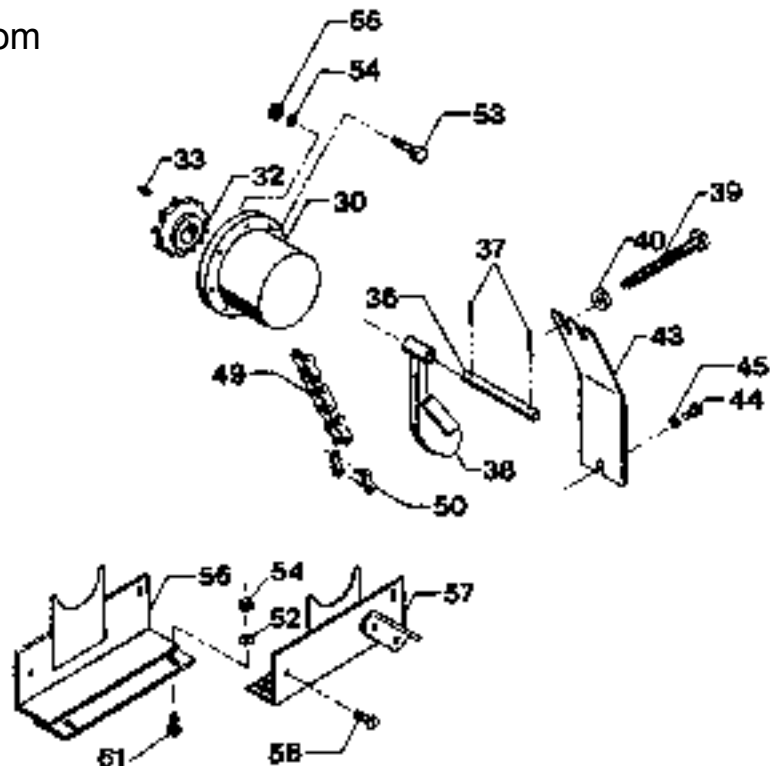

FEEDER & SCREW PLANETARY, SPROCKET & CHAIN

BI-876-5245B

(Before Ordering, Consult Table of Contents to Verify Proper Bill of Material Number.)

REF.	PART NUMBER	QTY.	DESCRIPTION
30	27X04	2	Planetary, Feeder & Screw (See Section 12 For Breakdown)
32	AB-19-480W	2	Sprocket, 12 T.
33	T-17-33	2	Key, 1/2" Square x 2" (Heat Treated)
36	E1-17-25	1	Pin
37	27D71	2	Pin, Cotter - 1/4" x 1.50"
38	BA-876-5247W	2	Take-Up
39	BF-876-5253	2	3/4" x 9.25" Hex Head Bolt
40	27D01	2	3/4" Hex Jam Nut
43	DD-876-5248	1	Plate, Cover
44	26C53	1	3/8" x 1.00" Hex Head Cap Screw
45	27L78	1	3/8" Lock Washer
49	12R00	2	Chain, Roller ASA #120 x 61 Links
50	12R01	2	Link, Connecting
52	27L58	3	1/2" Cut Washer
53	26C56	18	1/2" x 2.25" Hex Head Cap Screw
54	27L81	22	1/2" Lock Washer
55	27C95	18	1/2" Hex Nut
56	ABI-876-5247W	1	Cover, Sprocket
57	FAI-876-5247W	1	Cover, Sprocket
59	12T09	2	1/2" x 1" Flat Socket Head Cap Screw
	26E28	2	1/2" x 1.25" Hex Head Cap Screw
	27L58	2	1/2" Cut Washer
61	26E28	2	1/2" x 1.25" Hex Head Cap Screw

□ - For Offset Link order 12R02

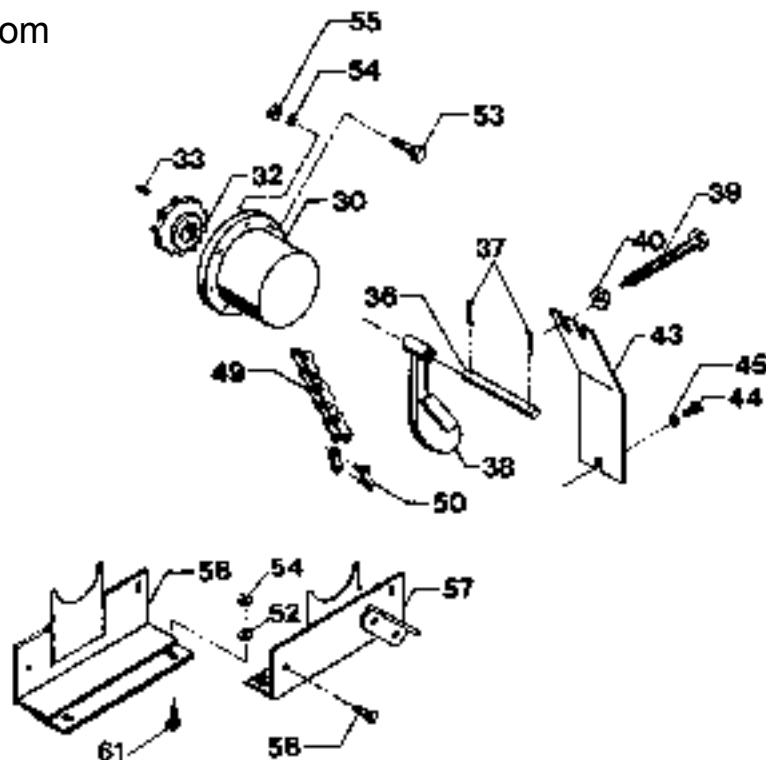

FEEDER & SCREW PLANETARY, SPROCKET & CHAIN

B2-876-5245B

(Before Ordering, Consult Table of Contents to Verify Proper Bill of Material Number.)

REF.	PART NUMBER	QTY.	DESCRIPTION
30	27X04	2	Planetary, Feeder & Screw (See Section 12 For Breakdown)
32	AK-19-480W	2	Sprocket, 15 T.
33	T-17-33	2	Key, 1/2" Square x 2" (Heat Treated)
36	E1-17-25	1	Pin
37	27D71	2	Pin, Cotter - 1/4" x 1.50"
38	BA-876-5247W	2	Take-Up
39	BF-876-5253	2	3/4" x 9.25" Hex Head Bolt
40	27D01	2	3/4" Hex Jam Nut
43	DD-876-5248	1	Plate, Cover
44	26C53	1	3/8" x 1.00" Hex Head Cap Screw
45	27L78	1	3/8" Lock Washer
	12R02	2	Link, Offset
49	12R00	2	Chain, Roller ASA #120 x 63 Links
50	12R01	2	Link, Connecting
52	27L58	3	1/2" Cut Washer
53	26C56	18	1/2" x 2.25" Hex Head Cap Screw
54	27L81	22	1/2" Lock Washer
55	27C95	18	1/2" Hex Nut
56	ABI-876-5247W	1	Cover, Sprocket
57	FAI-876-5247W	1	Cover, Sprocket
58	12T09	2	1/2" x 1" Flat Socket Head Cap Screw
	26E28	2	1/2" x 1.25" Hex Head Cap Screw
	27L58	2	1/2" Cut Washer
61	26E28	2	1/2" x 1.25" Hex Head Cap Screw

9/4/90 (1-16)

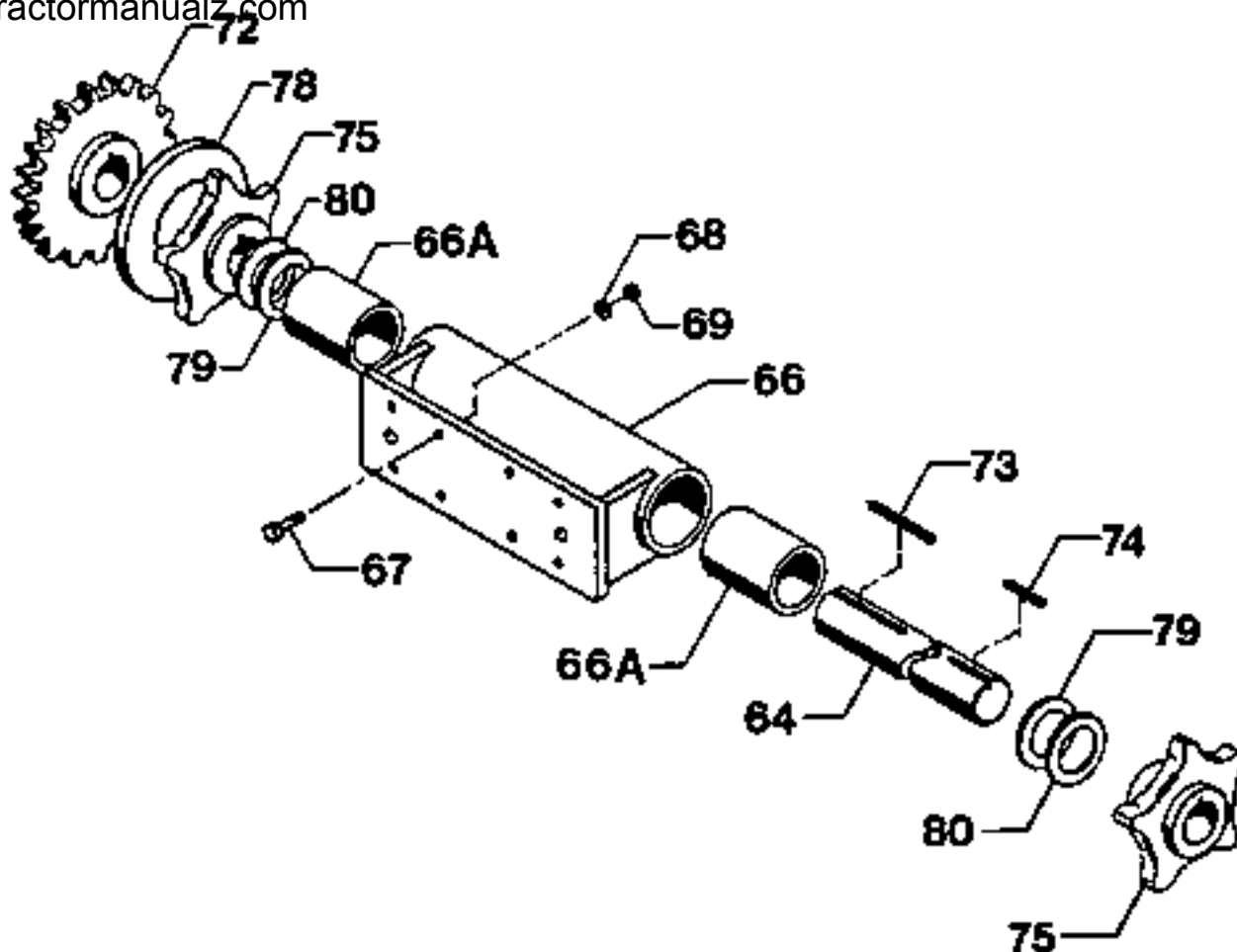

FEEDER HEAD SHAFT
(Standard Duty)

C-876-5245B

(Before Ordering, Consult Table of Contents to Verify Proper Bill of Material Number.)

REF.	PART NUMBER	QTY.	DESCRIPTION
64	HA-876-5248	2	Shaft
66	DA-876-5247W	2	Support, Bronze Bushing (Consisting in part of the following indented item):
66A	E-8-121	2	. Bushing
67	12K25	16	5/8" x 2.50" Hex Head Cap Screw (Grade 8)
68	27M04	16	5/8" Lock Washer (Internal - External)
69	12K53	16	5/8" Hex Nut
72	B-19-2478W	2	Sprackle, 24 T.
73	AM-17-41	2	Key, 3/4" Square x 5.62"
74	TT-17-41	2	Key, 3/4" Square x 2.75"
75	A-19-2471	4	Sprocket, 5 T.
78	A-17-586	2	Ring, Seal
79	BF-17-164	4	Washer, Bronze - 11 Ga.
80	BC-17-164	8	Washer, Bronze - 18 Ga.
	CR-17-165	10	Shim, 16 Ga. (As Required)
	CS-17-165	6	Shim, 24 Ga. (As Required)

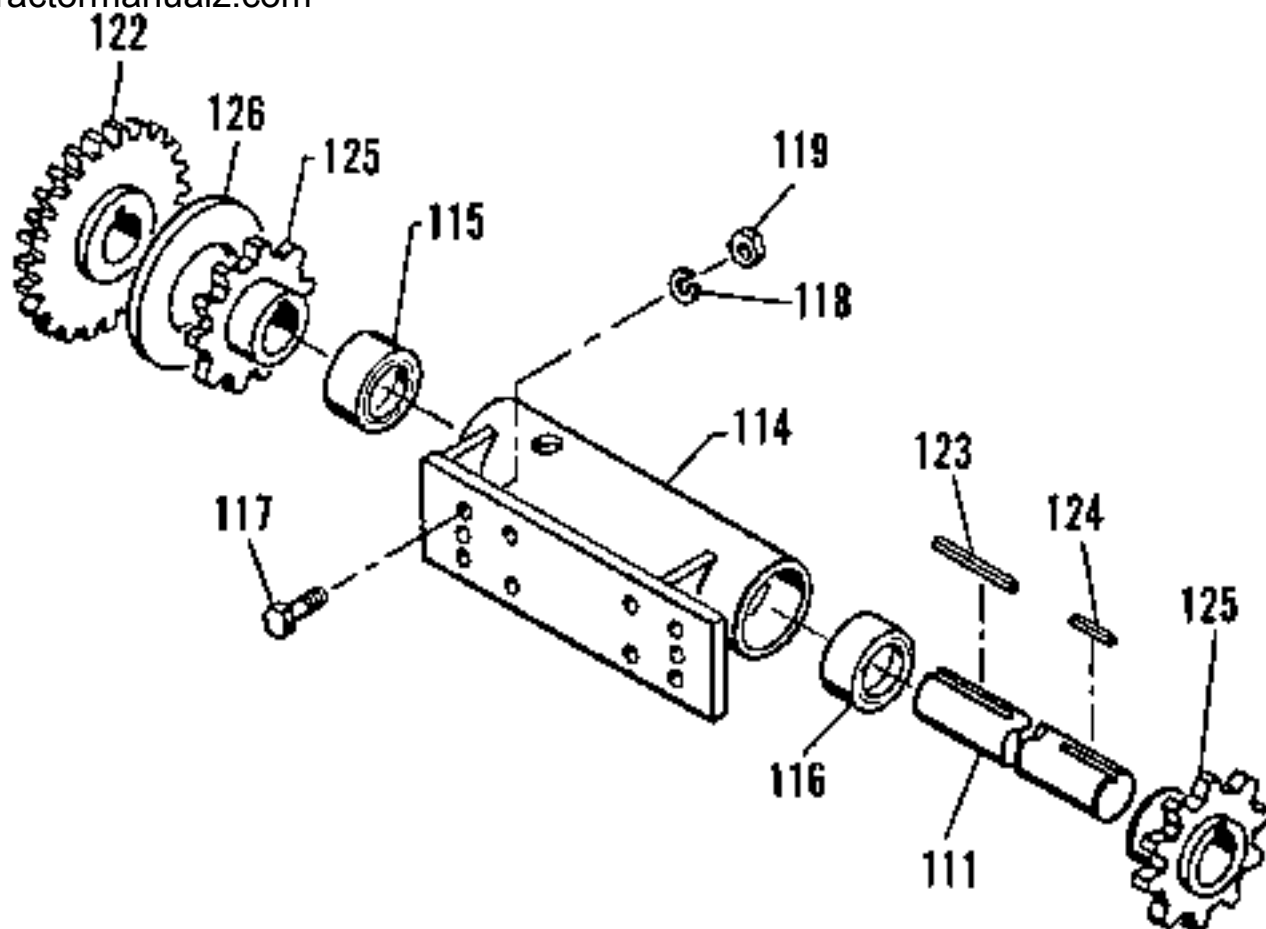

**FEEDER HEAD SHAFT
(Heavy Duty)**

E-876-5245B

(Before Ordering, Consult Table of Contents to Verify Proper Bill of Material Number.)

REF.	PART NUMBER	QTY.	DESCRIPTION
111	HA-876-5248	2	Shaft
114	EA-876-5247W	2	Support, Bearing
115	27X22	2	Bearing, Inboard
116	28Y97	2	Bearing, Outboard
117	12K25	16	5/8" x 2.50" Hex Head Cap Screw (Grade 8)
118	27M04	16	5/8" Lock Washer
119	12K53	16	5/8" Heavy Hex Nut
122	B-19-2478	2	Sprocket, 24 T.
123	KP-17-41	2	Key, 3/4" Square x 5.75"
124	C-17-41	2	Key, 3/4" Square x 3.00"
125	A-19-2473	4	Sprocket, 10 T.
126	A-17-586	2	Ring, Seal

2/22/91 (1-18)

FEEDER HEAD SHAFT GREASE PIPING

D-876-5245B

(Before Ordering, Consult Table of Contents to Verify Proper Bill of Material Number.)

REF.	PART NUMBER	QTY.	DESCRIPTION
	23C59	4	Fitting, 1/8" N.P.T.F. Str, Lube
	23M16	4	Connector, 1/4" N.P.T.F. x 1/4" Tube
	27L58	4	1/2" Cut Washer
	26L14	4	Nipple, Reducer - 1/4" N.P.T.F. x 1/8" N.P.T.F.
	23F06	4	Connector, 1/8" N.P.T.F. x 1/4" Tube
	11T75	6	Clamp
	26B89	6	1/4" x 1/2" Self Tapping Round Head Cap Screw
	L-80-434W	2	Tube Assembly, 1/4" x 10'-0"
	M-80-434W	2	Tube Assembly, 1/4" x 9'-0"
	10B23	8	Strap, Cable

FEEDER HEAD SHAFT GREASE PIPING

F-876-5245B

(Before Ordering, Consult Table of Contents to Verify Proper Bill of Material Number.)

REF.	PART NUMBER	QTY.	DESCRIPTION
	23C59	4	Fitting, 1/8" N.P.T.F. Alemite Str. Lube
	23M16	4	Connector, 1/4" N.P.T.F. x 1/4" Tube
	27L58	4	1/2" Cut Washer
	26L14	4	Nipple, Reducer, 1/4" N.P.T.F. x 1/8" N.P.T.F.
	23F06	4	Connector, 1/8" N.P.T.F. x 1/4" Tube
	11T75	6	Clamp
	26B89	6	1/4"-20 x 1/2" Self-Tap Round Head Cap Screw
	N-80-434W	4	Tube Assembly, 1/4" x 72"

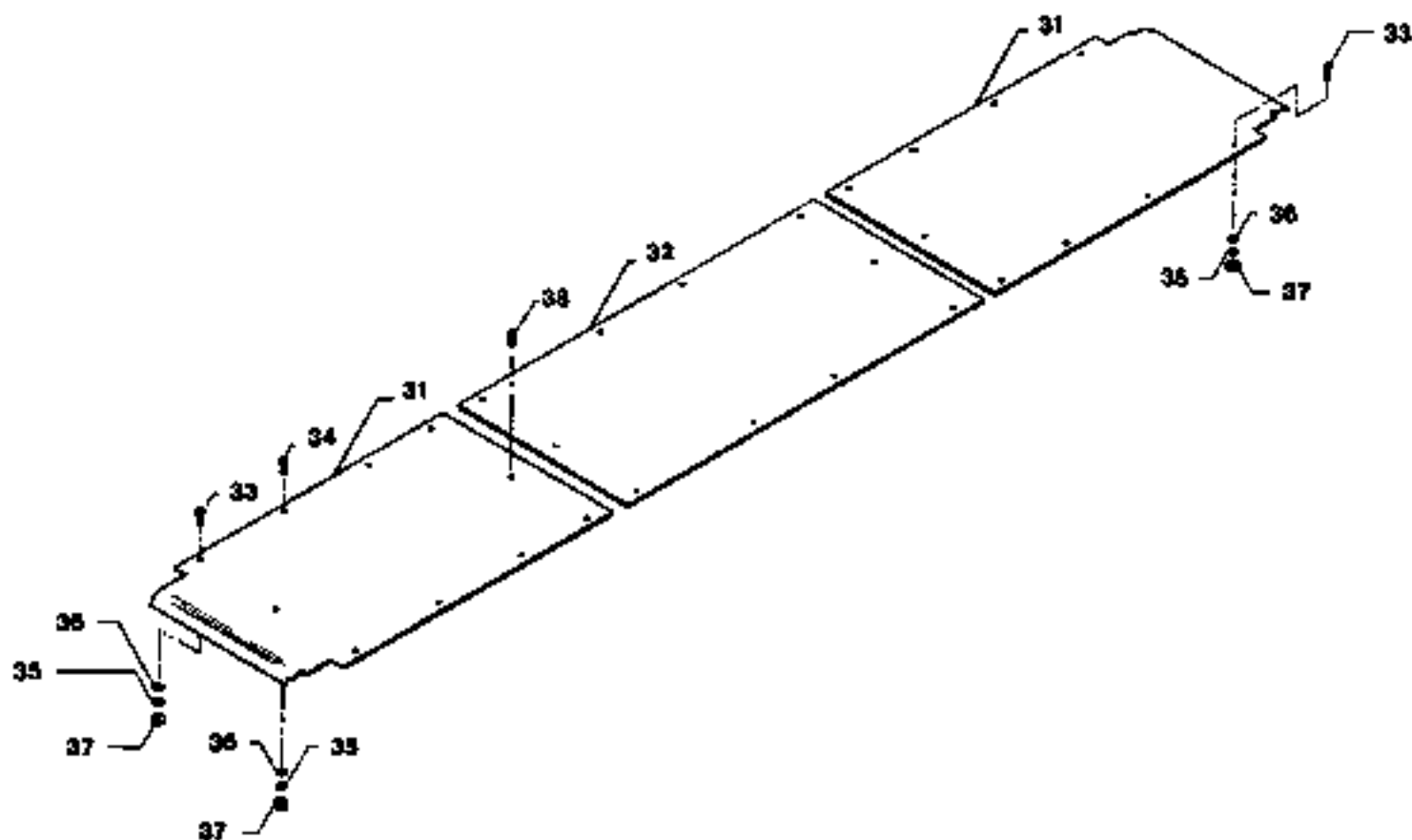

FEEDER DRAG PANS

H-876-5245B

(Before Ordering, Consult Table of Contents to Verify Proper Bill of Material Number.)

REF.	PART NUMBER	QTY.	DESCRIPTION
31	B-876-5248	4	Pan, Feeder Drag (Front & Rear)
32	A-876-5248	2	Pan, Feeder Drag (Center)
33	27F65	12	1/2" x 1.75" Flat Head Cap Screw
34	27F62	48	1/2" x 1.25" Flat Head Cap Screw
35	27L58	60	1/2" Cut Washer
36	27L81	60	1/2" Lock Washer
37	27C95	60	1/2" Hex Nut
38	27F61	6	1/2" x 1" Flat Head Cap Screw

5/1/90 (2-11)

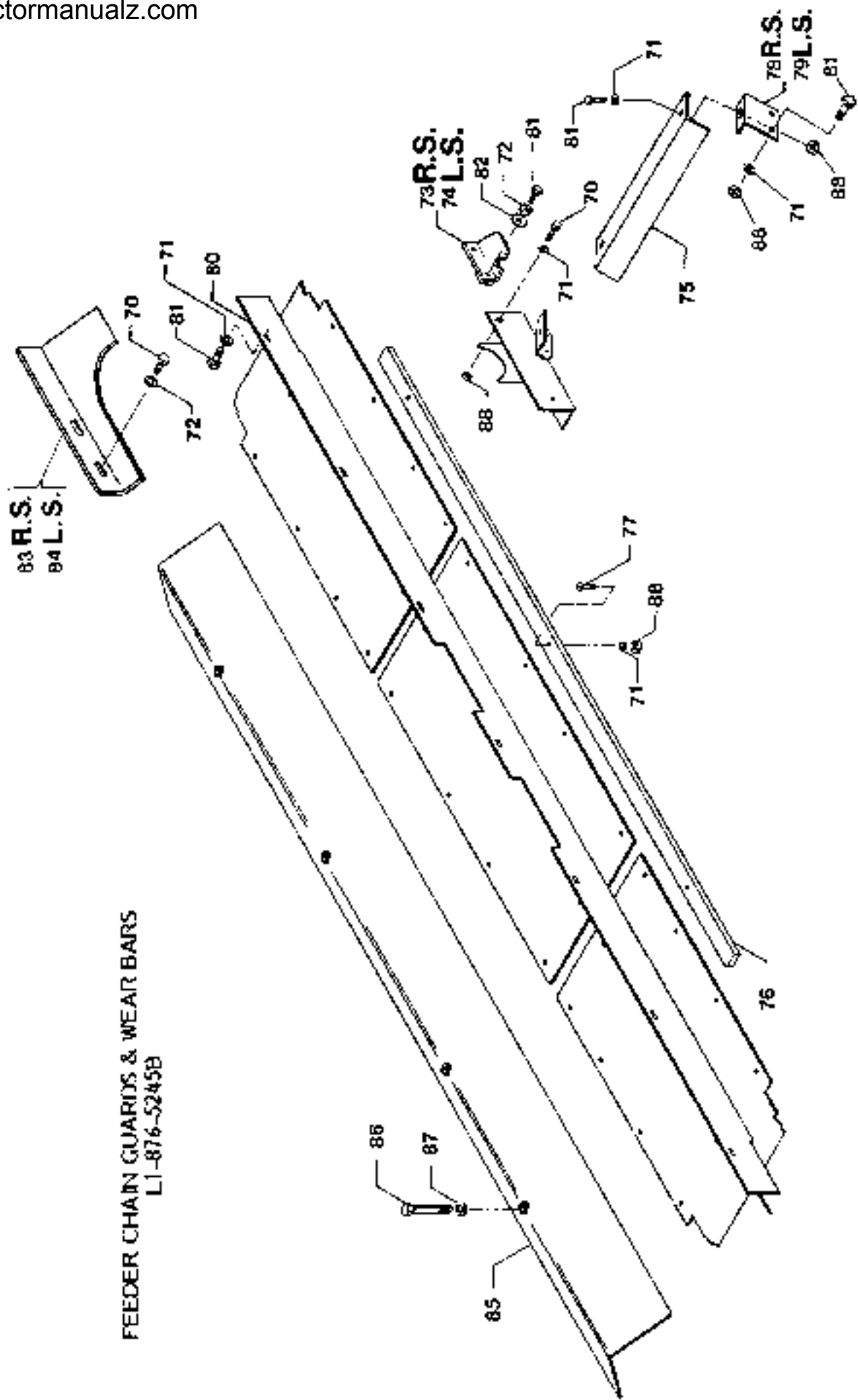

FEEDER CHAIN GUARDS & WEAR BARS

L1-876-5245B

(Before Ordering, Consult Table of Contents to Verify Proper Bill of Material Number.)

REF.	PART NUMBER	QTY.	DESCRIPTION
Ref. #70 thru #88 Symbolized by NONE on Illustration.			
70	26E24	14	1/2" x 1.00" Hex Head Cap Screw
71	27L58	20	1/2" Cut Washer
72	27L81	40	1/2" Lock Washer
73	VC-876-5247WR	1	Deflector, Center
74	VC-876-5247WL	1	Deflector, Center
75	CC-876-5248	2	Deflector
76	CD-876-5248	4	Bar, Wear
77	27F67	12	1/2" x 2.00" Flat Head Cap Screw
78	FA-876-5249	1	Support, Deflector
79	FB-876-5249	1	Support, Deflector
80	A-876-5247W	2	Guard, Chain
81	26E28	12	1/2" x 1.25" Hex Head Cap Screw
82	27L59	4	5/8" Cut Washer
83	RA-876-5247W	1	Guard, Chain (Center) (Right Rear)
84	RB-876-5247W	1	Guard, Chain (Center) (Left Rear)
85	E-876-5247W	1	Guard, Chain (Center)
86	20N57	4	5/8" x 8" Hex Head Cap Screw
87	26F83	4	5/8" Hardened Washer
88	27C95	20	1/2" Hex Nut
	13J37	4	1/2" x 1.75" Hex Head Cap Screw
	KD-17-9	18	Shim (Steel Washer)

SECTION 6

BG-220B Asphalt Paver

SCREW CONVEYOR COMPONENTS

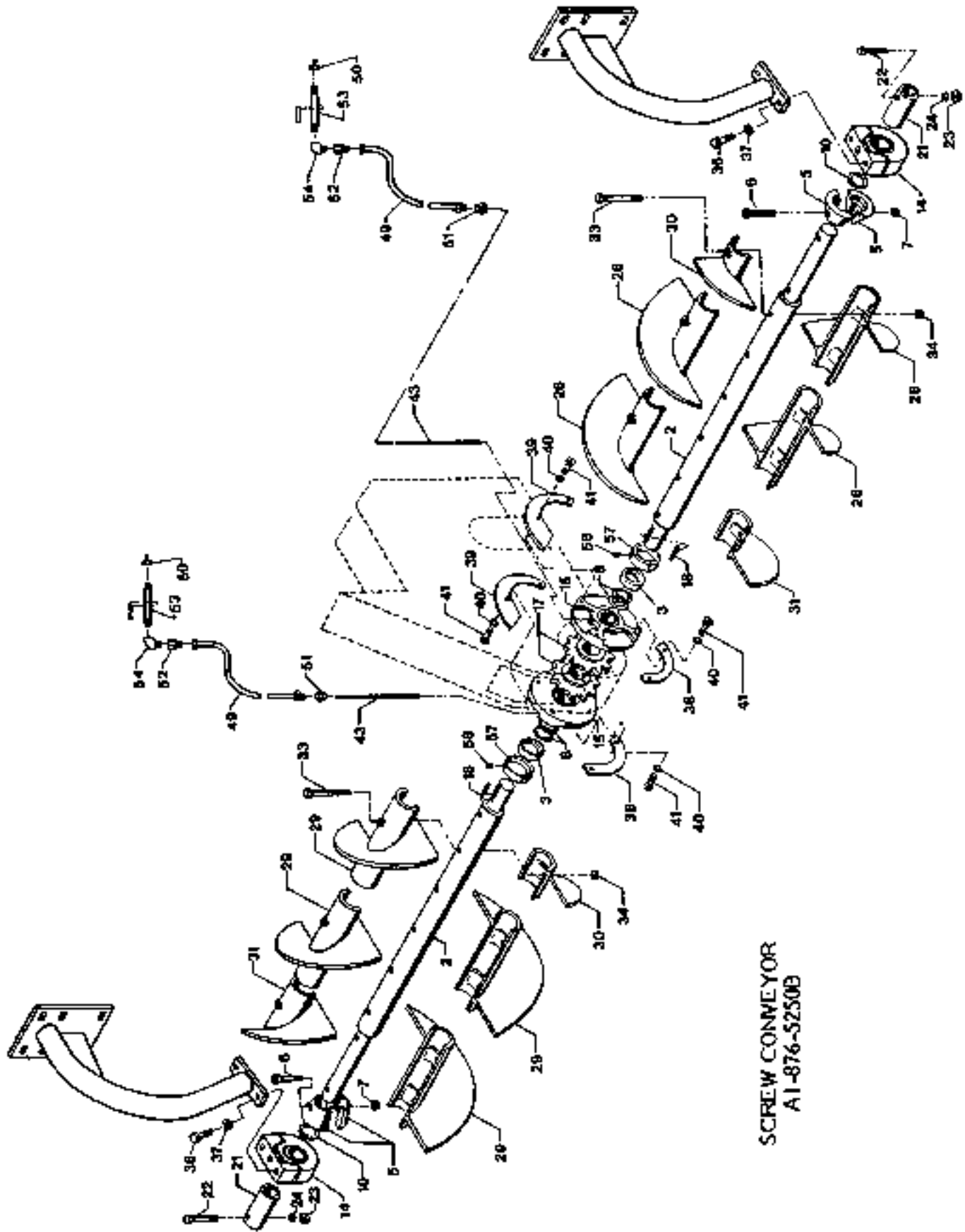

SCREW CONVEYOR
A1-876-5250B

SCREW CONVEYOR

AI-876-5250B

(Before Ordering, Consult Table of Contents to Verify Proper Bill of Material Number.)

REF.	PART NUMBER	QTY.	DESCRIPTION
Ref. #2 thru #58 Symbolized by NONE on Illustration.			
2	AAI-876-5253	2	Shaft
3	FD-876-5253	2	Spacer
5	C-3-4581C	4	Seal, Bearing
6	26B93	2	1/2" x 4" Socket Head Cap Screw
7	12Z45	2	1/2" Hex Lock Nut
8	AK-17-219	4	Washer, 2.03" I.D. x 2.50" O.D. x .16 Ga.
10	DR-17-478	2	Washer, 2.06 I.D. x 2.75" O.D. x .38"
14 a	12P89	2	Bearing, Hanger - 2.00" Dia.
15 a	12P90	2	Bearing, Flanged - 2.00" Dia.
17	AB-19-480W	2	Sprocket, 12 T.
18	U-17-33	2	Key, 1/2" Square x 2-1/4"
21	K-876-1773	2	Cover
22	26A03	2	1/2" x 3-1/2" Hex Head Cap Screw
23	27C95	2	1/2" Hex Nut
24	27L81	2	1/2" Lock Washer
28	A-3-4640C	4	Segment, Screw 1/2
29	B-3-4640C	4	Segment, Screw 1/2
30	C-3-4640C	2	Segment, Screw 1/4
31	D-3-4640C	2	Segment, Screw 1/4
33	14J49	10	1/2" x 5" Hex Head Cap Screw
34	12Z45	10	1/2" Hex Lock Nut
36	26C48	4	5/8" x 1-1/2" Hex Head Cap Screw
37	27L84	4	5/8" Lock Washer
38	AF-876-73	2	Plate, Wear
39	AG-876-73	2	Plate, Wear
40	27L81	8	1/2" Lock Washer
41	26D36	8	1/2" x 1.50" Socket Head Cap Screw
43	I-17-119	2	Nipple, Pipe - 1/8" x 1 1/4"
49	14P16	2	Hose Assembly, 3/16" I.D. x 36"
50	23C59	2	Fitting, Lubrication - 1/8"
51	23M16	2	Connector, 1/4" Tube x 1/4" N.P.T.F. (Body Only)
52	26L14	2	Reducer, Nipple - 1/4" N.P.T.F. x 1/8" N.P.T.F.
53	28M75	2	Coupling, Pipe x 1/8" N.P.T.F.
54	23H48	2	Elbow, 90° Street, Short, 1/4" M. N.P.T.F. x 1/4" F.
57	FE-876-5253	2	Seal, Bearing
58	27L11	4	3/8" x 1/2" Socket Head Set Screw

a - For Insert order 12P89C1.

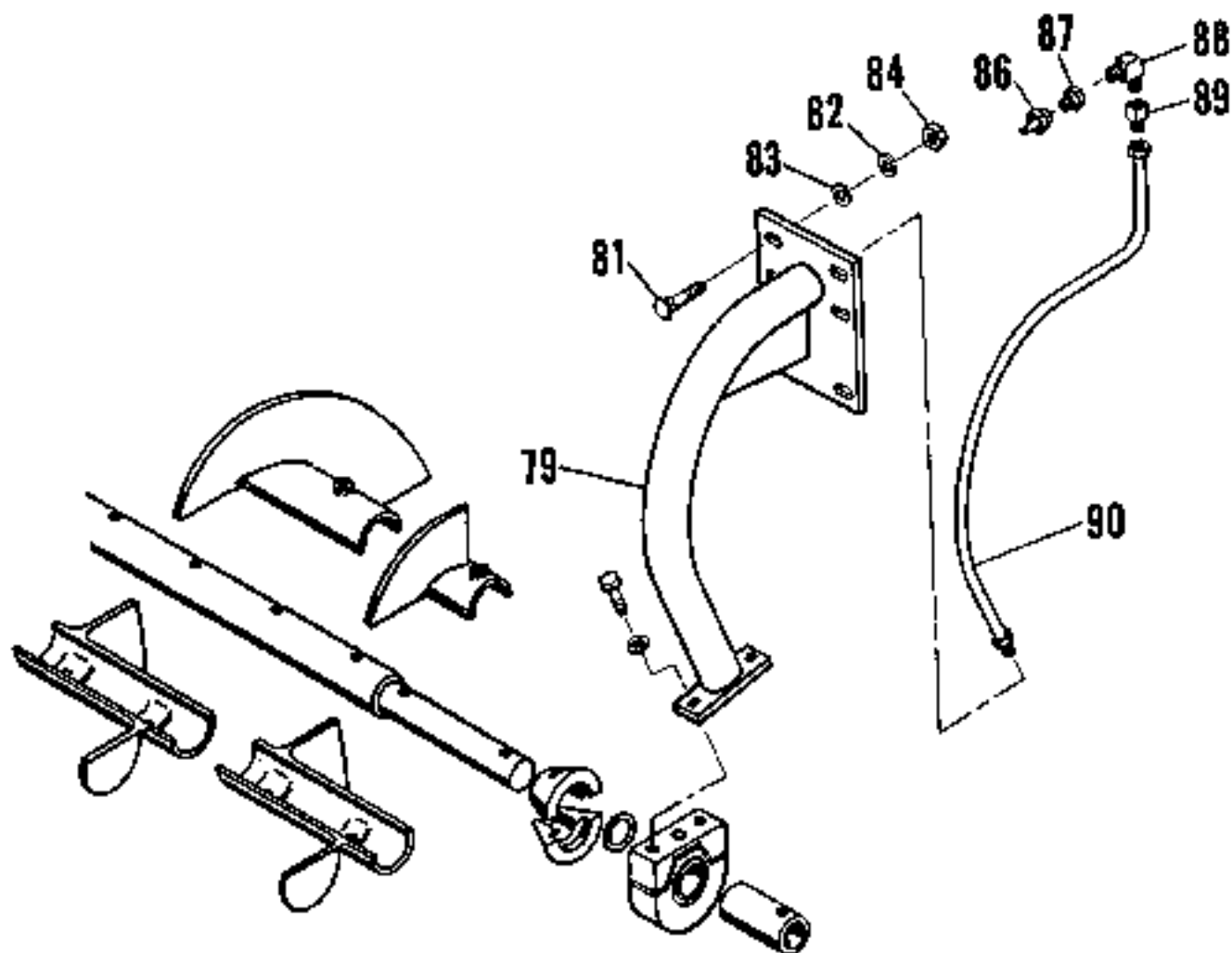

OUTER SCREW CONVEYOR SUPPORTS

B2-876-5250B

(Before Ordering, Consult Table of Contents to Verify Proper Bill of Material Number.)

REF.	PART NUMBER	QTY.	DESCRIPTION
79	GB-876-5252W	2	Support, Outer Bearing
81	10T69	12	5/8" x 2" Carriage Bolt
82	27L84	12	5/8" Lock Washer
83	27L59	12	5/8" Cut Washer
84	27C98	12	5/8" Hex Nut
86	23C59	2	Fitting, 1/8" Female Grease
87	26L14	2	Nipple, Reducer - 1/4" N.P.T.F. x 1/8" N.P.T.F.
88	23H48	2	Elbow, 90°, 51.5 Short x 1/4" N.P.T.F.
89	23M16	2	Connector, Body - 1/4" T. Swivel x 1/4" Fe. N.P.T.F.
90	14P16	2	Hose Assembly, 3/16" I.D. x 36" - 1/8" M. N.P.T. x 1/4" Swivel J.I.C.

2/25/89 (1-7)

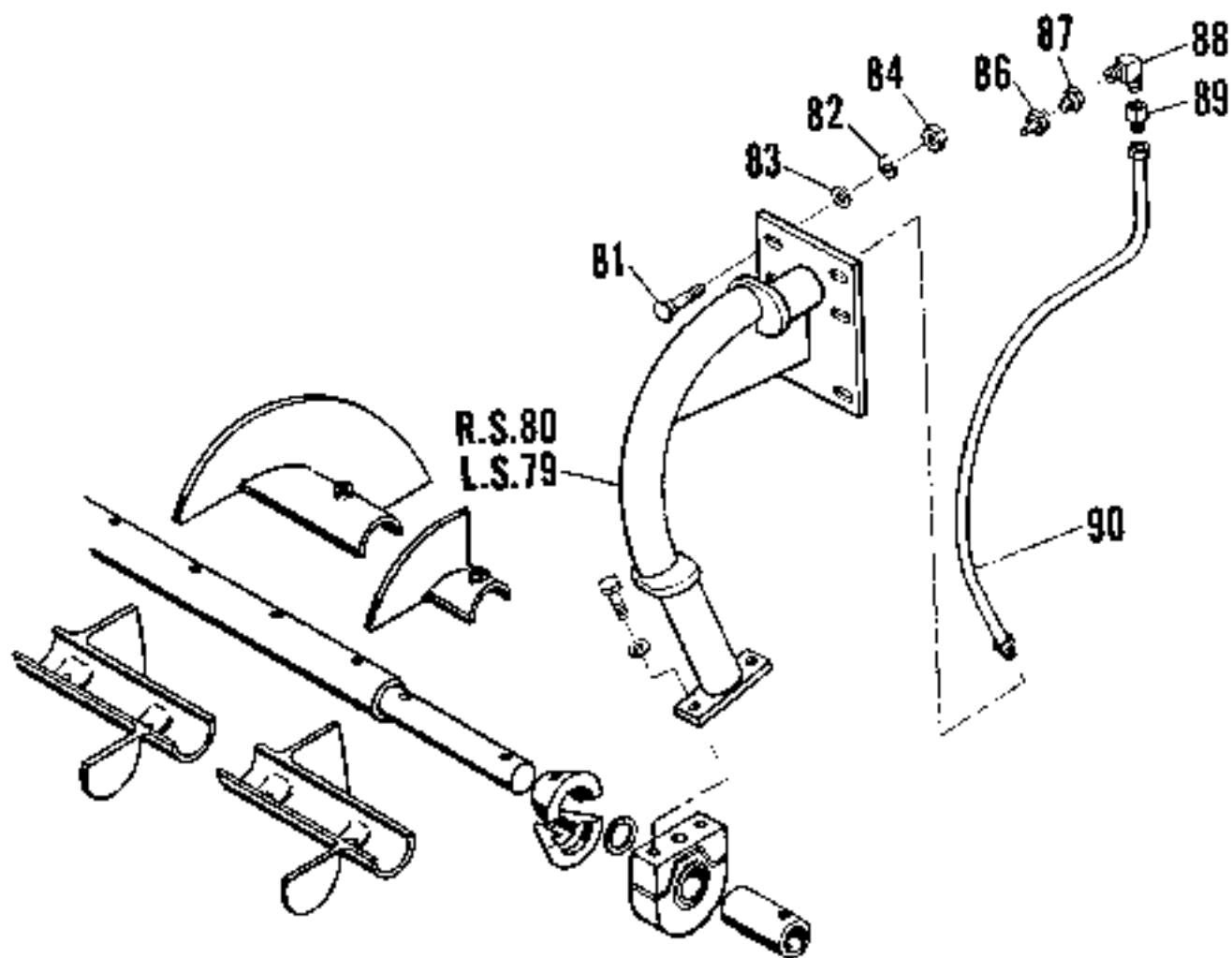

OUTER SCREW CONVEYOR SUPPORTS

B3-876-5250B

(Before Ordering, Consult Table of Contents to Verify Proper Bill of Material Number.)

REF.	PART NUMBER	QTY.	DESCRIPTION
79	VB-876-5592W	1	Support, Outer Bearing (Left Side)
80	VC-876-5592W	1	Support, Outer Bearing (Right Side)
81	10T69	12	5/8" x 2" Carriage Bolt
82	27L84	12	5/8" Lock Washer
83	27L59	12	5/8" Cut Washer
84	27C98	12	5/8" Hex Nut
86	23C59	2	Fitting, 1/8" Female Grease
87	26L14	2	Nipple, Reducer - 1/4" N.P.T.F. x 1/8" N.P.T.F.
88	23H49	2	Elbow, 90°, St. Short x 1/4" N.P.T.F.
89	23M16	2	Connector, Body - 1/4" T. Swivel x 1/4" Fe. N.P.T.F.
90	14P16	2	Hose Assembly, 3/16" I.D. x 36" - 1/8" M. N.P.T. x 1/4" Swivel J.I.C.

2/25/89 (1-9)

**SCREW CONVEYOR BEARING SUPPORT & SHAFT
(For Wide Width Paving)**

C-876-52500

(Before Ordering, Consult Table of Contents to Verify Proper Bill of Material Number.)

REF.	PART NUMBER	QTY.	DESCRIPTION
	DA-876-5252W	1	Support, Bearing (Right Side)
	DB-876-5252W	1	Support, Bearing (Left Side)
	26C49	6	5/8" x 1.75" Hex Head Cap Screw
	27L84	6	5/8" Lock Washer
	27L59	6	5/8" Cut Washer
	27C98	6	5/8" Hex Nut
a	12P89	2	Bearing, Hanger - 2.00" Dia.
	26C48	4	5/8" x 1.50" Hex Head Cap Screw
	27L84	4	5/8" Lock Washer
	C-17-177	2	Pipe, 1/8" x 7.50"
	23C59	2	Fitting, 1/8" Female
	C-3-4581C	4	Deflector
	AK-17-219	4	Shim, 16 Ga.
	EZ-17-9	2	Washer
	26B93	2	1/2" x 4" Hex Head Cap Screw
	26A38	2	1/2" Lock Nut
	AE-876-1773	2	Shaft
	AP-876-1773	2	Pipe
	12K46	2	1/2" x 5" Hex Head Cap Screw (Grade 8)
	12Z45	2	1/2" Lock Nut

a - For Insert order 12P89C1.

**SCREW CONVEYOR EXTENSIONS & COMPONENTS
(For Wide Width Paving)**

- H-876-365B (Hemi-Screw) (14" Diameter) (1'-0" Long)
- J-876-365B (Hemi-Screw) (14" Diameter) (2'-0" Long)
- AC-876-1965B (Screw Conveyor Extension End Cover)
- AD-876-2560B (Hemi-Screw) (14" Diameter) (0'-6" Long)
- AE-876-2560B (NI-Hard Bolt On Segments) (14" Diameter) (0'-10" Long)

(Before Ordering, Consult Table of Contents to Verify Proper Bill of Material Number.)

REF.	PART NUMBER	QTY.	DESCRIPTION
<u>H-876-365B ONLY</u>			
	AF-876-1773	2	Shaft
	AJ-876-1773	2	Pipe
	C-3-4640C	2	Segment, 1/4 Screw (Right Side)
	A-3-4640C	1	Segment, 1/2 Screw (Right Side)
	14J49	4	1/2" x 5" Hex Head Cap Screw
	12Z45	4	1/2" Lock Nut
	D-3-4640C	2	Segment, 1/4 Screw (Left Side)
	B-3-4640C	1	Segment, 1/2 Screw (Left Side)
	QN-17-9	8	Washer
<u>J-876-365B ONLY</u>			
	AF-876-1773	2	Shaft
	AC-876-1773	2	Pipe
	C-3-4640C	2	Segment, 1/4 Screw (Right Side)
	A-3-4640C	3	Segment, 1/2 Screw (Right Side)
	14J49	8	1/2" x 5" Hex Head Cap Screw
	12Z45	8	1/2" Lock Nut
	QN-17-9	16	Washer
	D-3-4640C	2	Segment, 1/4 Screw (Left Side)
	B-3-4640C	3	Segment, 1/2 Screw (Left Side)
<u>AC-876-1965B ONLY</u>			
	AP-876-1773	2	Pipe
	12K46	2	1/2" x 5" Hex Head Cap Screw (Grade 8)
	12Z45	2	1/2" Lock Nut
<u>AD-876-2560B ONLY</u>			
	C-3-4640C	2	Segment, 1/4 Screw (14" Diameter)
	D-3-4640C	2	Segment, 1/4 Screw (14" Diameter)
	AP-876-1773	2	Pipe
	14J49	2	1/2" x 5" Hex Head Cap Screw
	12Z45	2	1/2" Lock Nut
	QN-17-9	2	Washer

REF. PART NUMBER	QTY.	DESCRIPTION
<u>AE-876-25608 ONLY</u>		
KA-876-1967W	1	Extension, Screw (14" Diameter)
LA-876-1967W	1	Extension, Screw (14" Diameter)
26A03	2	1/2" x 3-1/2" Hex Head Cap Screw
12Z45	2	1/2" Lock Nut
A-3-4555C	7	Segment, Ni-Hard
AA-3-4555C	7	Segment, Ni-Hard
26C84	14	1/2" x 1-1/2" Carriage Bolt
26D02	14	1/2" Hex Nut
27L81	14	1/2" Lock Washer
27L58	28	1/2" Cut Washer

SECTION 7

BG-220B Asphalt Paver

LEVELING ARMS, TOW POINTS & SCREED TRAVEL SUPPORT

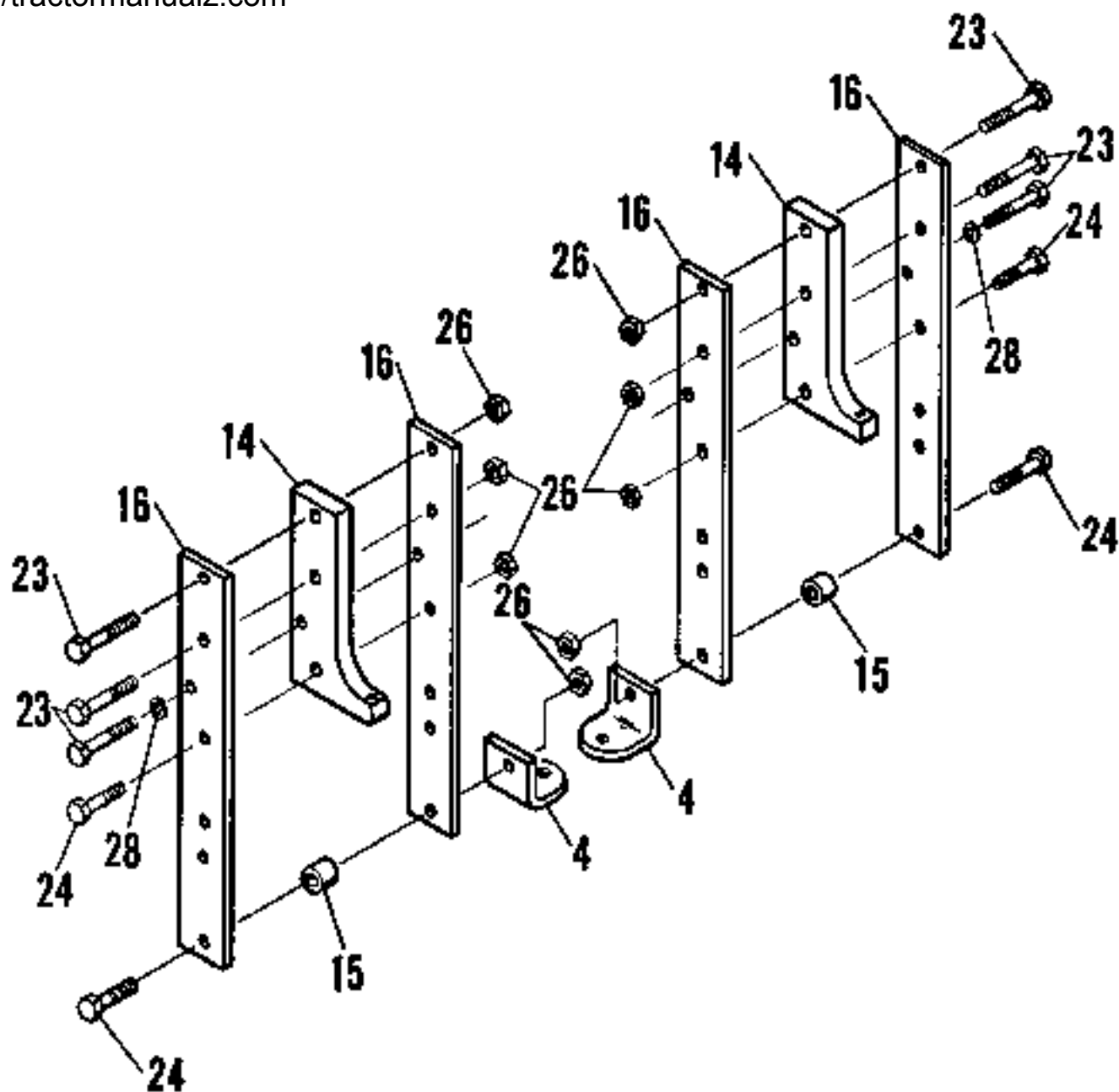

TOW POINTS

A3-876-5255B

(Before Ordering, Consult Table of Contents to Verify Proper Bill of Material Number.)

REF.	PART NUMBER	QTY.	DESCRIPTION
4	CC-876-5328	2	Support, Mainframe Extension Brace
14	AC-876-5258	2	Block, Spacer
15	BD-876-5258	2	Spacer, 2" Diameter
16	AA2-876-5258	4	Bar, Inside Guide
23	20M23	6	1" x 4.50" Hex Head Cap Screw
24	12B38	4	1" x 3.50" Hex Head Cap Screw
26	12R38	8	1" Lock Nut
28	27M05	2	1" Lock Washer

3/25/87 (1-7)

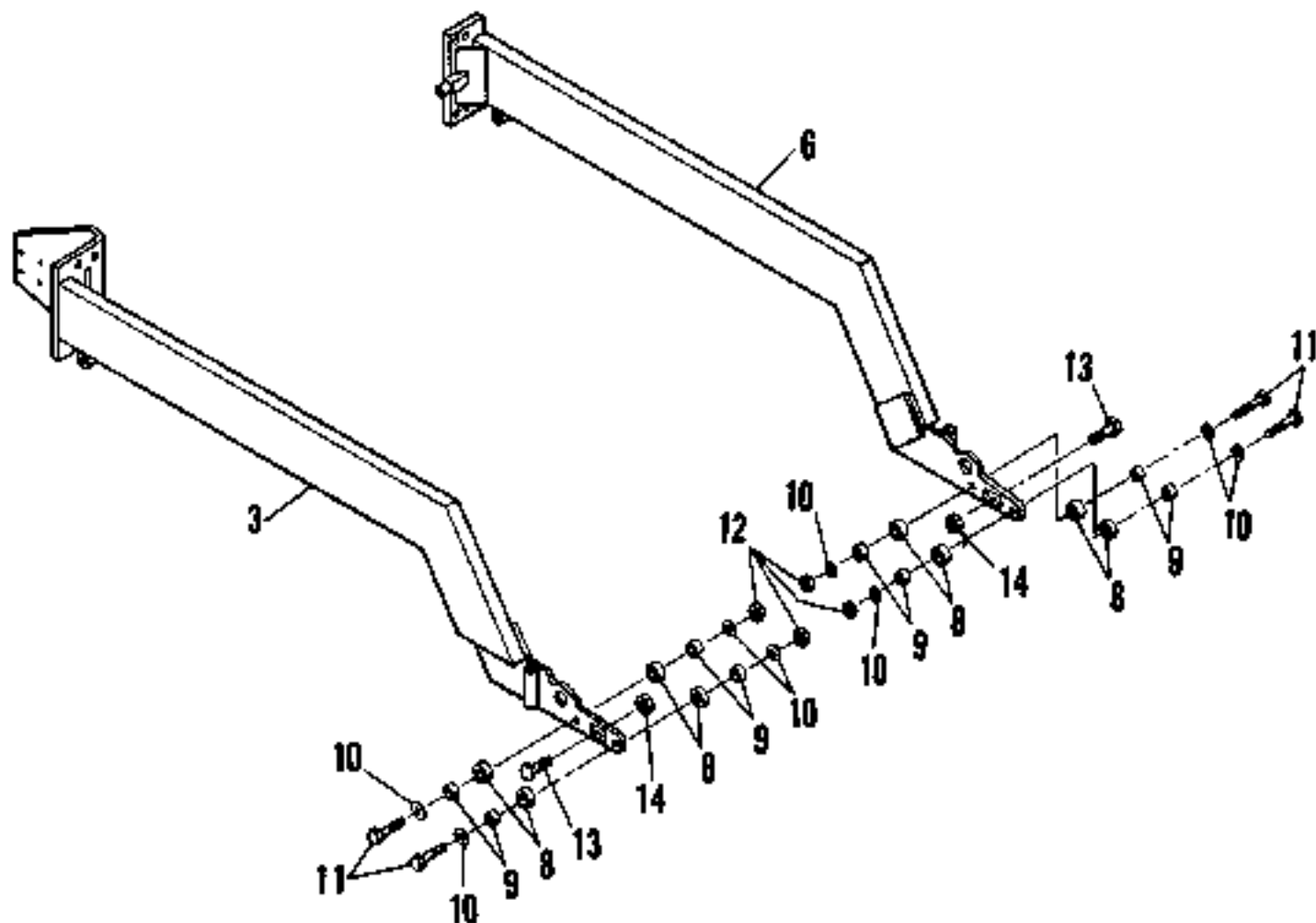

LEVELING ARMS

A2-876-5260B

(Before Ordering, Consult Table of Contents to Verify Proper Bill of Material Number.)

REF.	PART NUMBER	QTY.	DESCRIPTION
3	DA2-876-5262W	1	Arm, Leveling (Right Side)
6	EA2-876-5262W	1	Arm, Leveling (Left Side)
8	JB-876-5263	8	Roller
9	JC-876-5263	8	Spacer
10	26B48	8	3/4" Hardened Washer
11	16F51	4	3/4" x 4" Hex Head Cap Screw
12	26A41	4	3/4" Lock Nut
13	12R38	2	1" x 3.50" Hex Head Cap Screw (Without Auto Grade Control)
14	12R88	2	1" Lock Nut (Without Auto Grade Control)

3/25/87 (1-7)

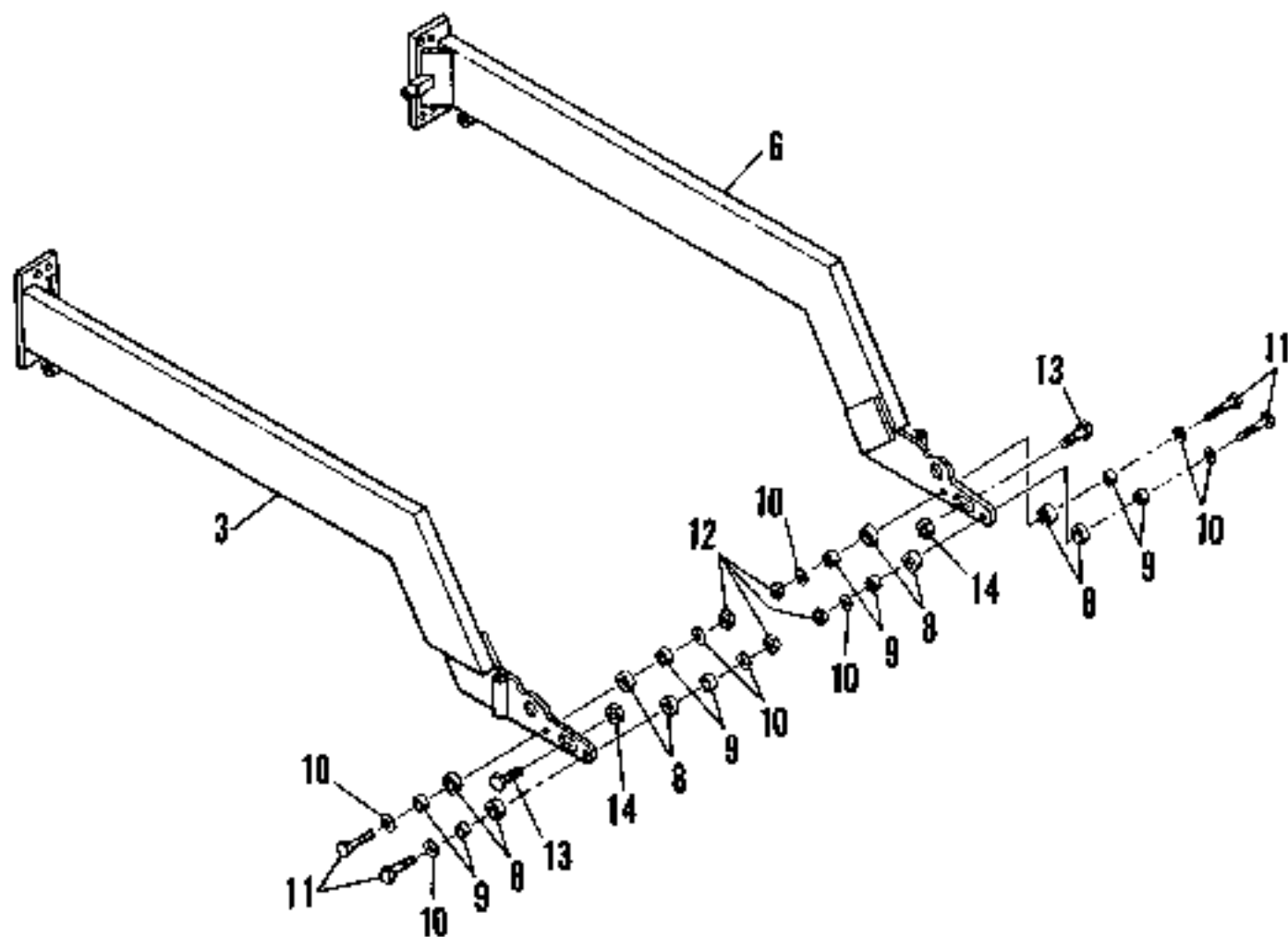

LEVELING ARMS

A3-876-5260B

(Before Ordering, Consult Table of Contents to Verify Proper Bill of Material Number.)

REF.	PART NUMBER	QTY.	DESCRIPTION
3	DA3-876-5262W	1	Arm, Leveling (Right Side)
6	EA2-876-5262W	1	Arm, Leveling (Left Side)
8	JB-876-5263	8	Roller
9	JC-876-5263	8	Spacer
10	26B48	8	3/4" Hardened Washer
11	16F51	4	3/4" x 4" Hex Head Cap Screw
12	26A41	4	3/4" Lock Nut
13	12B38	2	1" x 3.50" Hex Head Cap Screw (Without Auto Grade Control)
14	12R88	2	1" Lock Nut (Without Auto Grade Control)

2/25/89 (1-8)

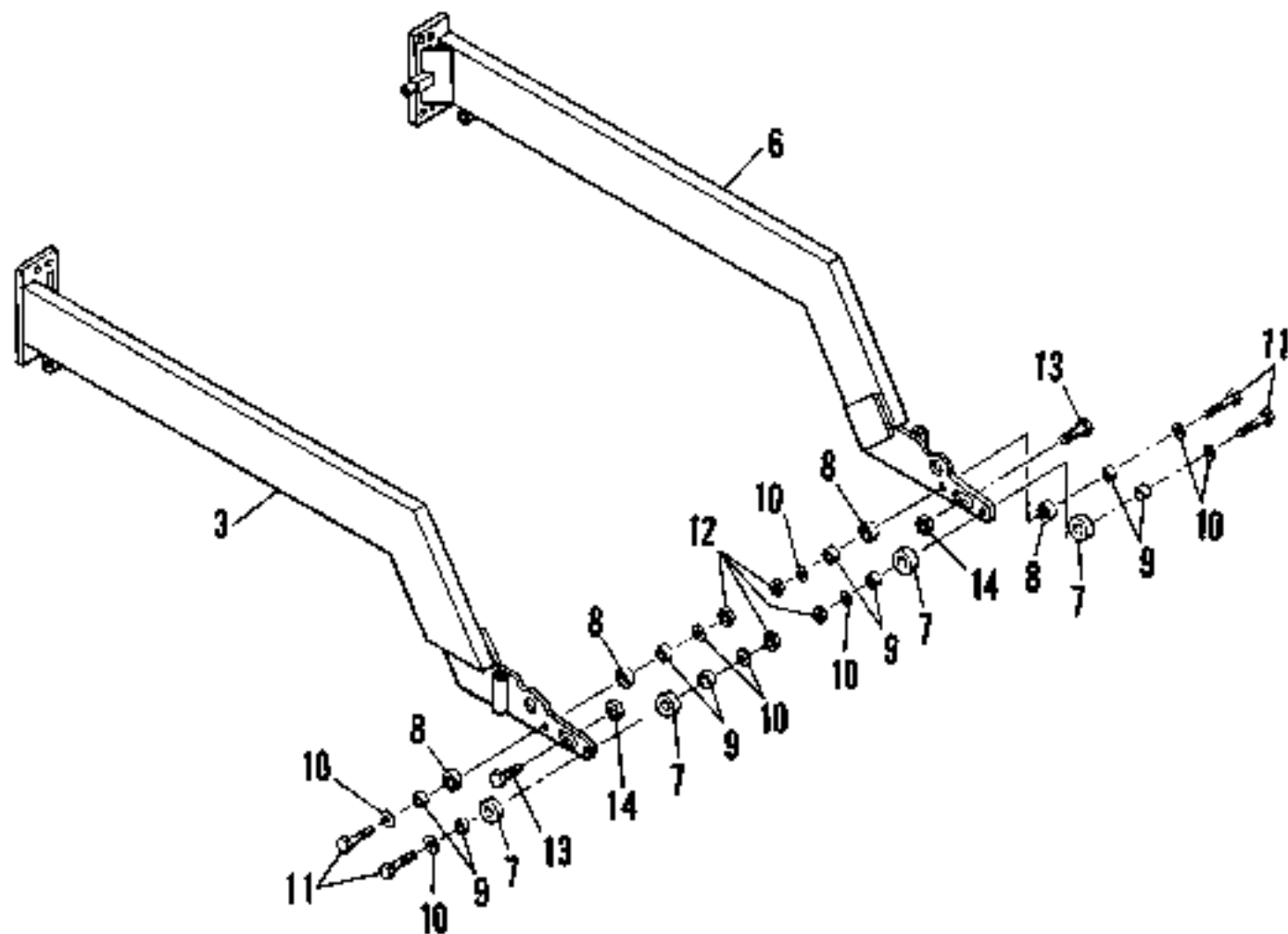

LEVELING ARMS

A4-876-5260B

(Before Ordering, Consult Table of Contents to Verify Proper Bill of Material Number.)

REF.	PART NUMBER	QTY.	DESCRIPTION
3	DA3-876-5262W	1	Arm, Leveling (Right Side)
6	EA2-876-5262W	1	Arm, Leveling (Left Side)
7	JE-876-5263	4	Roller (Front)
8	JB-876-5263	4	Roller (Rear)
9	JC-876-5263	8	Spacer
10	26B48	8	3/4" Hardened Washer
11	16F51	4	3/4" x 4" Hex Head Cap Screw
12	26A41	4	3/4" Lock Nut
13	12B38	2	1" x 3.50" Hex Head Cap Screw (Without Auto Grade Control)
14	12R88	2	1" Lock Nut (Without Auto Grade Control)

2/25/89 (1-9)

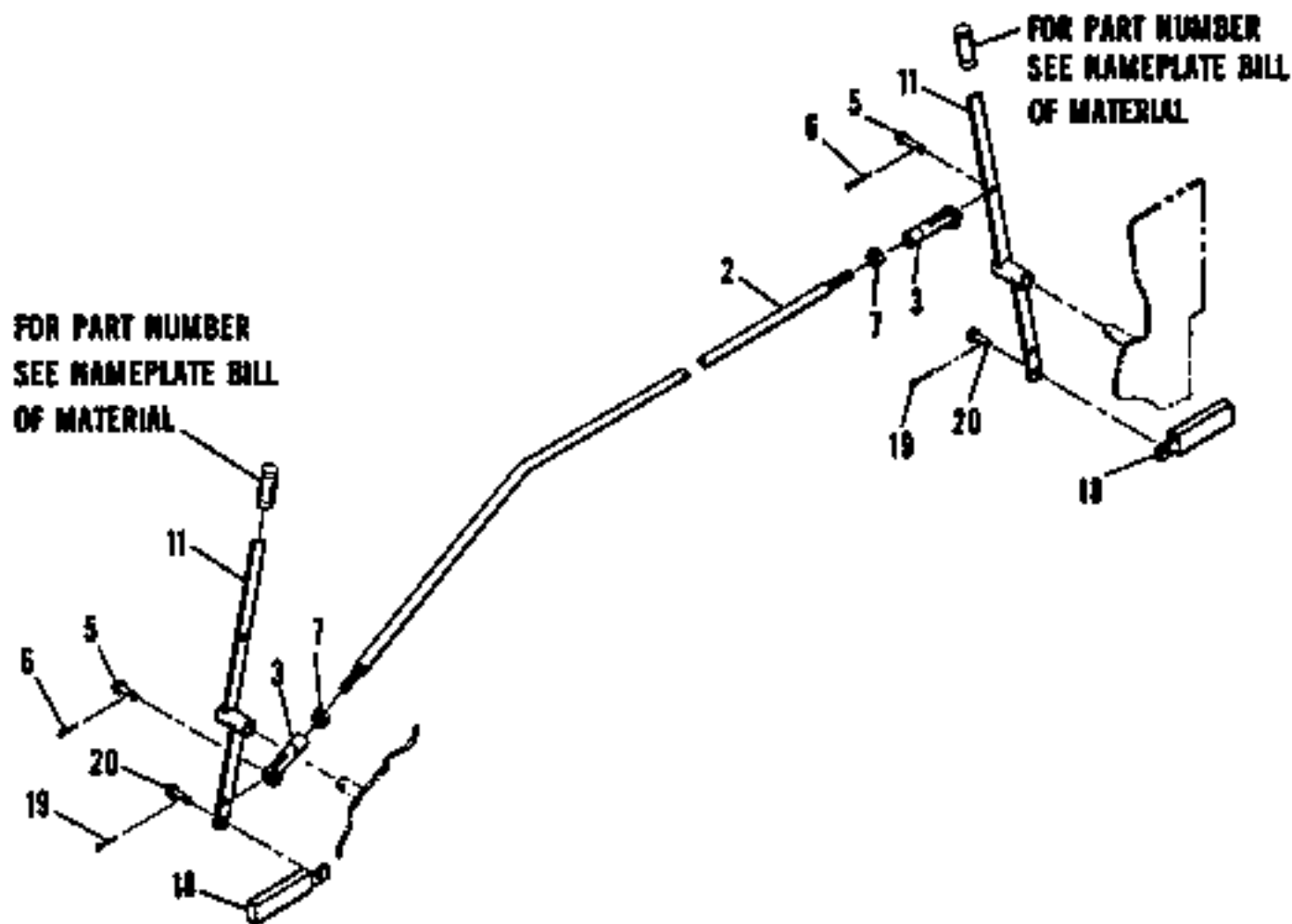

SCREED TRAVEL SUPPORT

A-876-5270B

(Before Ordering, Consult Table of Contents to Verify Proper Bill of Material Number.)

REF.	PART NUMBER	QTY.	DESCRIPTION
2	A-876-5273	1	Shaft, Cross
3	50D83	2	Clevis, Rod End - 5/8"-18 U.N.F. x 1/2" Pin Hole
5	50P78	2	Pin, Clevis - 1/2" Dia. x 1-25/32"
6	27D53	2	Pin, Cotter - 1/8" Dia. x 1.00"
7	27D23	2	5/8"-18 U.N.F. Jam Nut
11	A-876-5272W	2	Lever
18	AC2-876-4717W	2	Bar, Lock
19	27D53	2	Pin, Cotter - 1/8" Dia. x 1.00"
20	Z-17-23	2	Pin, Clevis - 1/2" Dia. x 1.25"

2/25/89 (1-1)

SECTION 8

BG-220B Asphalt Paver

OPERATORS' STATION

OPERATOR'S STATION & MECHANICAL CONTROLS
A2-876-5490B

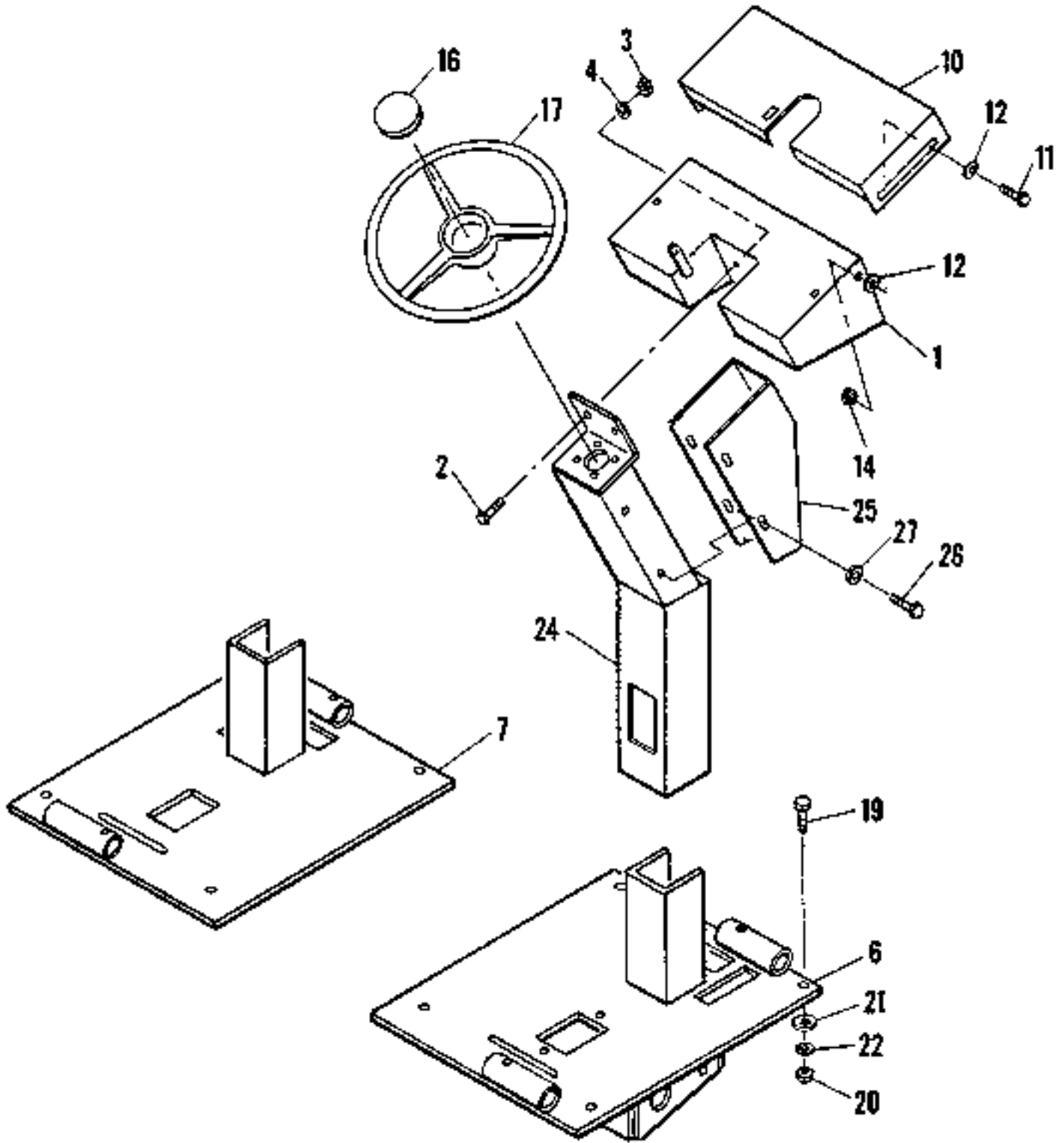

OPERATOR'S STATION & MECHANICAL CONTROLS

A2-876-5490B

(Before Ordering, Consult Table of Contents to Verify Proper Bill of Material Number.)

REF.	PART NUMBER	QTY.	DESCRIPTION
Ref. #1 thru #27 Symbolized by NONE on Illustration.			
1	HA-876-5492W	1	Operator's Station
2	26C53	2	3/8" x 1" Hex Head Cap Screw
3	27C90	2	3/8" Nut
4	27L78	2	3/8" Lock Washer
6	AA2-876-5492W	1	Platform, Operator's (R.H.)
7	BA2-876-5492W	1	Platform, Operator's (L.H.)
10	KA-876-5493	1	Cover, Vandal
11	14A13	2	3/8" x 1-1/4" Hex Head Cap Screw
12	14A15	4	3/8" Cut Washer
14	14A17	2	3/8" Nut
16	28G96	1	Cap, Steering Wheel
17	28G97	1	Wheel, Steering
19	10V14	8	3/8" x 1-1/4" Hex Head Cap Screw
20	27C90	8	3/8" Nut
21	27L56	8	3/8" Cut Washer
22	27L78	8	3/8" Lock Washer
24	GA-876-5492W	1	Support, Station
25	GB-876-5492W	1	Cover, Support
26	26L55	4	1/4" x 5/8" Hex Head Cap Screw
27	27L52	4	1/4" Cut Washer
	27L76	4	1/4" Lock Washer

OPERATOR'S STATION & MECHANICAL CONTROLS
A3-876-5490B

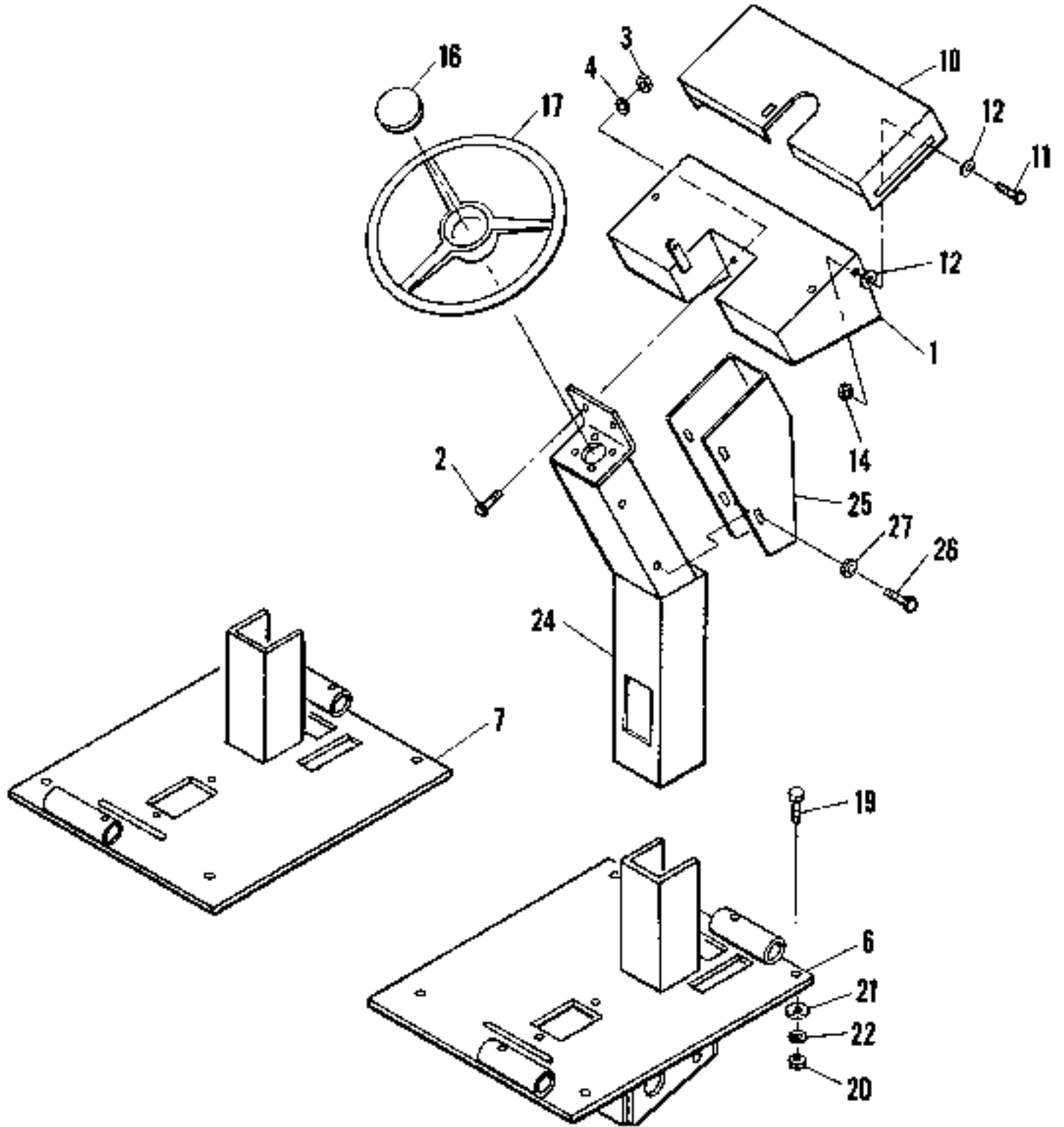

OPERATOR'S STATION & MECHANICAL CONTROLS

A3-876-5490B

(Before Ordering, Consult Table of Contents to Verify Proper Bill of Material Number.)

REF.	PART NUMBER	QTY.	DESCRIPTION
Ref. #1 thru #27 Symbolized by NONE on Illustration.			
1	HA-876-5492W	1	Operator's Station
2	26C53	2	3/8" x 1" Hex Head Cap Screw
3	27C90	2	3/8" Nut
4	27L78	2	3/8" Lock Washer
6	MA-876-5492W	1	Platform, Operator's (R.H.)
7	LA-876-5492W	1	Platform, Operator's (L.H.)
10	KA-876-5493	1	Cover, Vandal
11	14A13	2	3/8" x 1-1/4" Hex Head Cap Screw
12	14A15	4	3/8" Cut Washer
14	14A17	2	3/8" Nut
16	28G96	1	Cap, Steering Wheel
17	28G97	1	Wheel, Steering
19	10V14	8	3/8" x 1-1/4" Hex Head Cap Screw
20	27C90	8	3/8" Nut
21	27L56	8	3/8" Cut Washer
22	27L78	8	3/8" Lock Washer
24	GA-876-5492W	1	Support, Station
25	GB-876-5492W	1	Cover, Support
26	26L55	4	1/4" x 5/8" Hex Head Cap Screw
27	27L52	4	1/4" Cut Washer
	27L76	4	1/4" Lock Washer

OPTIONAL OPERATOR'S STATION & MECHANICAL CONTROLS
BI-876-5490B

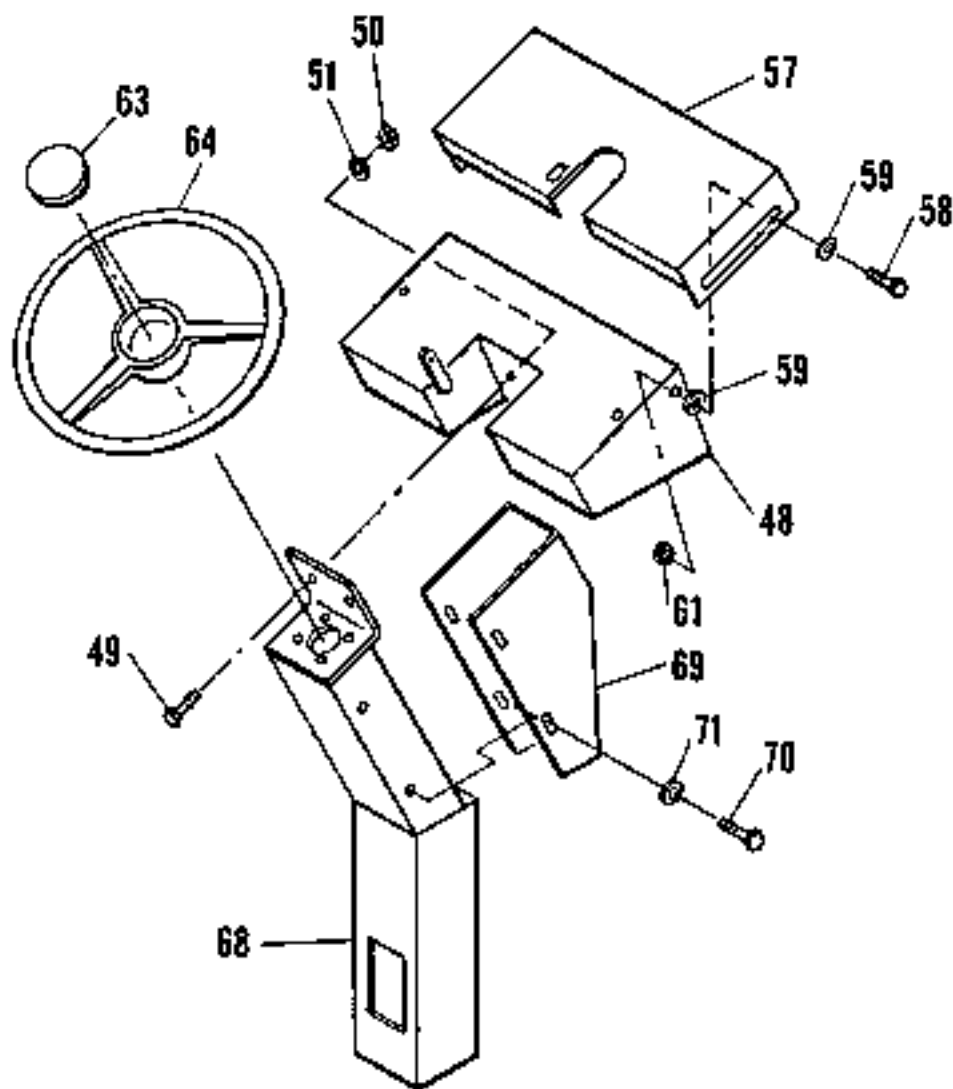

OPTIONAL OPERATOR'S STATION & MECHANICAL CONTROLS

81-876-5490B

(Before Ordering, Consult Table of Contents to Verify Proper Bill of Material Number.)

REF.	PART NUMBER	QTY.	DESCRIPTION
Ref. #48 thru #71 Symbolized by NONE on Illustration.			
48	HA-876-5492W	1	Operator's Station
49	26C53	2	3/8" x 1" Hex Head Cap Screw
50	27C90	2	3/8" Nut
51	27L78	2	3/8" Lock Washer
57	KA-876-5493	1	Cover, Vandal
58	14A13	2	3/8" x 1-1/4" Hex Head Cap Screw
59	14A15	4	3/8" Cut Washer
61	14A17	2	3/8" Nut
63	28C96	1	Cap, Steering Wheel
64	28C97	1	Wheel, Steering
68	GA-876-5492W	1	Support, Station
69	GB-876-5492W	1	Cover, Support
70	26L55	4	1/4" x 5/8" Hex Head Cap Screw
71	27L52	4	1/4" Cut Washer
	27L76	4	1/4" Lock Washer

STANDARD OPERATOR'S SEAT
(2 Required for Dual Operator's Station)

A-876-4790B

(Before Ordering, Consult Table of Contents to Verify Proper Bill of Material Number.)

REF.	PART NUMBER	QTY.	DESCRIPTION
	14Z51	1	Seat, Operator's (Consisting in part of the following indented items):
	14Z51C1	1	. Cushion, Back Rest
	14Z51C2	1	. Cushion, Seat
	A-876-4792W	1	Support, Seat
	27C87	4	5/16" Hex Nut
	27L77	4	5/16" Lock Washer
	AA-17-23	1	Pin, Clevis - 5/8" Dia. x 3-3/4"
	50H35	1	Pin, Retaining
	A-46-1945	1	Decal, Slow Moving Vehicle

DELUXE OPERATOR'S SEAT
(2 Required for Dual Operator's Station)

B1-876-4790B

(Before Ordering, Consult Table of Contents to Verify Proper Bill of Material Number.)

REF.	PART NUMBER	QTY.	DESCRIPTION
	27X58	1	Seat, Operator's (Consisting in part of the following indented items):
	27X58C1	1	. Armrest (L.H.)
	27X58C2	1	. Armrest (R.H.)
	A-876-4792W	1	Support, Seat
	27C87	4	5/16" Hex Nut
	27L77	4	5/16" Lock Washer
	AA-17-23	1	Pin, Clevis - 5/8" x 3-3/4"
	50H35	1	Pin, Retaining

SECTION 9

BG-220B Asphalt Paver

ELECTRICAL COMPONENTS

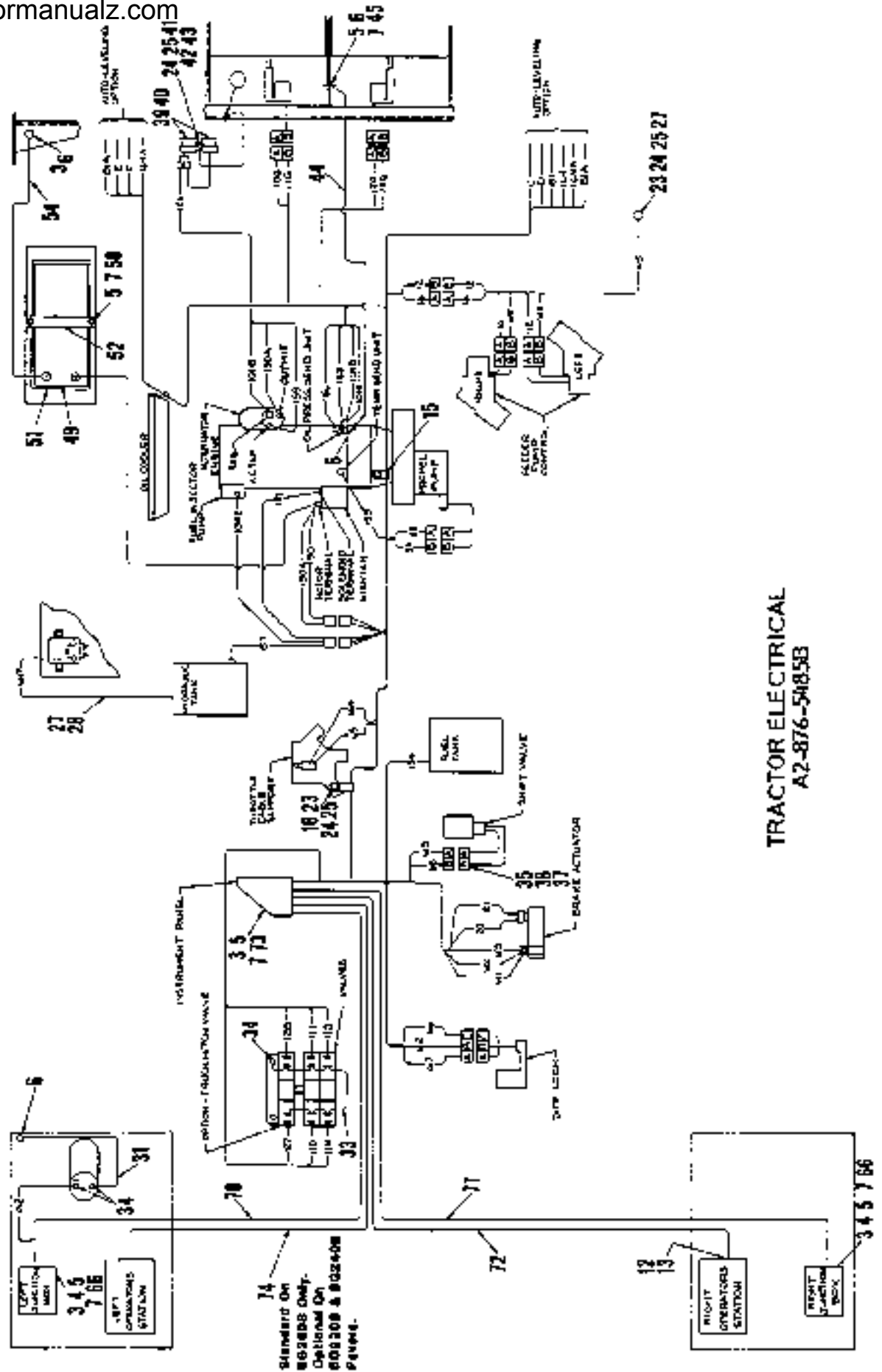

TRACTOR ELECTRICAL
A2-876-548.5B

TRACTOR ELECTRICAL

A2-876-5485B

(Before Ordering, Consult Table of Contents to Verify Proper Bill of Material Number.)

REF.	PART NUMBER	QTY.	DESCRIPTION
Ref. #3 thru #73 Symbolized by NONE on Illustration.			
3	26C53	9	3/8" x 1" Hex Head Cap Screw
4	27L56	4	3/8" Cut Washer
5	27L78	12	3/8" Lock Washer
6	26C97	6	3/8" Lock Washer (External Tooth)
7	27C90	17	3/8" Nut
a	28F14	1	Loom, Spiral Wrap x 8"
12	27X59	1	Fitting, Entrance
13	27J60	2	1/4" x 1/2" Round Head Machine Screw
15	28K31	2	Clamp
16	20K38	2	Clamp
	20K34	1	Clamp
	15Y67	1	Clamp
	15Y68	1	Clamp
	13J31	5	1/4" x 3/4" Hex Head Cap Screw
	27C86	4	1/4" Nut
	27L76	5	1/4" Lock Washer
23	26E25	4	5/16" x 3/4" Hex Head Cap Screw
24	27C87	7	5/16" Nut
25	27L77	5	5/16" Lock Washer
	27L52	1	5/16" Lock Washer
27	11E31	2	5/16" Lock Washer (External Tooth)
28	GA-876-5287W	1	Wire, Ground (Hydraulic Tank)
31	GB-876-5287W	1	Wire, Ground (Pump)
33	GA-876-5487W	1	Wire, Ground (Valve Bank)
34	11E30	3	1/4" Lock Washer (External Tooth)
35	28F22	1	Tower (Shift Valve)
36	28F31	2	Terminal, Female (Shift Valve)
37	28F32	2	Scal, Cable (Shift Valve)
39	10W96	1	Horn (Hi-Pitch)
40	10W97	1	Horn (Low Pitch)
41	23V67	1	5/16" x 1" Hex Head Cap Screw
42	27L54	2	5/16" Cut Washer
43	GC-876-5287W	1	Wire, Ground (Horn)
44	14N31	1	Wire, Ground (Engine)
45	10E10	1	3/8" x 1-1/4" Hex Head Cap Screw
49	b	1	Battery, 12 Volt (Wet)
50	A-17-301	2	Rod, Threaded
51	A-876-4693	2	Mat, Rubber
52	DB-876-5288	1	Bar, Hold Down
54	MB-876-5287W	1	Cable, Negative Battery
	10823	25	Ties, Plastic Wire
	11P81	12	Ties, Plastic Wire
	BC-876-5488	1	Bracket

REF.	PART NUMBER	QTY.	DESCRIPTION
66	BB-876-5488	1	Bracket
	10E10	4	3/8" x 1.25" Hex Head Cap Screw
	14Y5Z	50	Strap, Cable
	AA3-876-5485P	1	Electrical Package (Consisting of the following indented items):
70	XA-876-5487W	1	. Junction Box (Left Side) (See Section 9 Page 7)
71	XB-876-5487W	1	. Junction Box (Right Side) (See Section 9 Page 9)
72	VA-876-5487W	1	. Operator's Station Panel & Harness (Right Side) (See Section 9 Page 11)
73	SA-876-5487W	1	. Instrument Panel & Harness (See Section 9 Page 13)
	EE-876-5288	2	Shaft, 18.75" (For Feeder Electrical)

a - Be sure to specify length when ordering.

b - Purchase Locally.

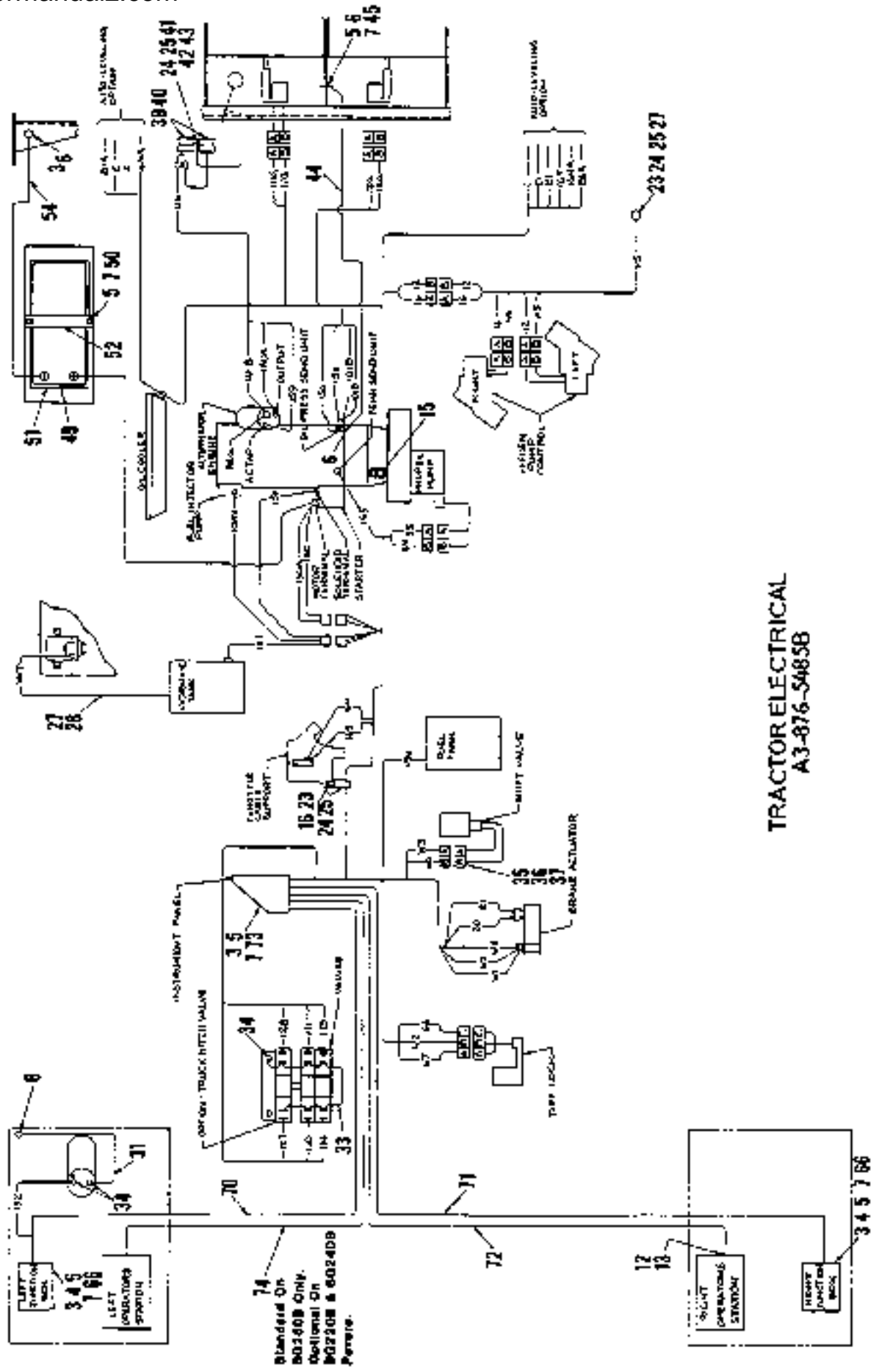

TRACTOR ELECTRICAL
A3-876-5485B

TRACTOR ELECTRICAL

A3-876-5485B

(Before Ordering, Consult Table of Contents to Verify Proper Bill of Material Number.)

REF.	PART NUMBER	QTY.	DESCRIPTION
Ref. #3 thru #73 Symbolized by NONE on Illustration.			
3	26C53	10	3/8" x 1" Hex Head Cap Screw
4	27L56	4	3/8" Cut Washer
5	27L78	13	3/8" Lock Washer
6	26C97	6	3/8" Lock Washer (External Tooth)
7	27C90	18	3/8" Nut
a	28F14	1	Loom, Spiral Wrap x 8"
	BD-876-5488	1	Bar, Support
	28K31	1	Clamp
12	27X59	1	Fitting, Entrance
13	27J60	2	1/4" x 1/2" Round Head Machine Screw
15	28K31	2	Clamp
16	20K38	2	Clamp
	20K34	1	Clamp
	15Y67	1	Clamp
	15Y68	1	Clamp
	13J31	5	1/4" x 3/4" Hex Head Cap Screw
	27C86	4	1/4" Nut
	27L76	5	1/4" Lock Washer
23	26E25	4	5/16" x 3/4" Hex Head Cap Screw
24	27C87	7	5/16" Nut
25	27L77	5	5/16" Lock Washer
	27L52	1	5/16" Lock Washer
27	11E31	2	5/16" Lock Washer (External Tooth)
28	GA-876-5287W	1	Wire, Ground (Hydraulic Tank)
31	GB-876-5287W	1	Wire, Ground (Pump)
33	GA-876-5487W	1	Wire, Ground (Valve Bank)
34	11E30	3	1/4" Lock Washer (External Tooth)
35	28F22	1	Tower (Shift Valve)
36	28F31	2	Terminal, Female (Shift Valve)
37	28F32	2	Seal, Cable (Shift Valve)
39	10W96	1	Horn (Hi-Pitch)
40	10W97	1	Horn (Low Pitch)
41	23V67	1	5/16" x 1" Hex Head Cap Screw
42	27L54	2	5/16" Cut Washer
43	GC-876-5287W	1	Wire, Ground (Horn)
44	14N31	1	Wire, Ground (Engine)
45	10E10	1	3/8" x 1-1/4" Hex Head Cap Screw
49	b	1	Battery, 12 Volt (Wet)
50	A-17-301	2	Rod, Threaded
51	A-876-4693	2	Mat, Rubber
52	DB-876-5288	1	Bar, Hold Down
54	MB-876-5287W	1	Cable, Negative Battery
	10B23	25	Ties, Plastic Wire

REF.	PART NUMBER	QTY.	DESCRIPTION
66	11P81	12	Ties, Plastic Wire
	10E10	4	3/8" x 1.25" Hex Head Cap Screw
	14Y52	50	Strap, Cable
	AA4-876-5485P	1	Electrical Package (Consisting of the following indented items):
70	XA1-876-5487W	1	. Junction Box (Left Side) (See Section 9 Page 8)
71	XB1-876-5487W	1	. Junction Box (Right Side) (See Section 9 Page 10)
72	VA-876-5487W	1	. Operator's Station Panel & Harness (Right Side) (See Section 9 Page 11)
73	SA-876-5487W	1	. Instrument Panel & Harness (See Section 9 Page 13)
	EE-876-5288	2	Shaft, 18.75" (For Feeder Electrical)

a - Be sure to specify length when ordering.

b - Purchase Locally.

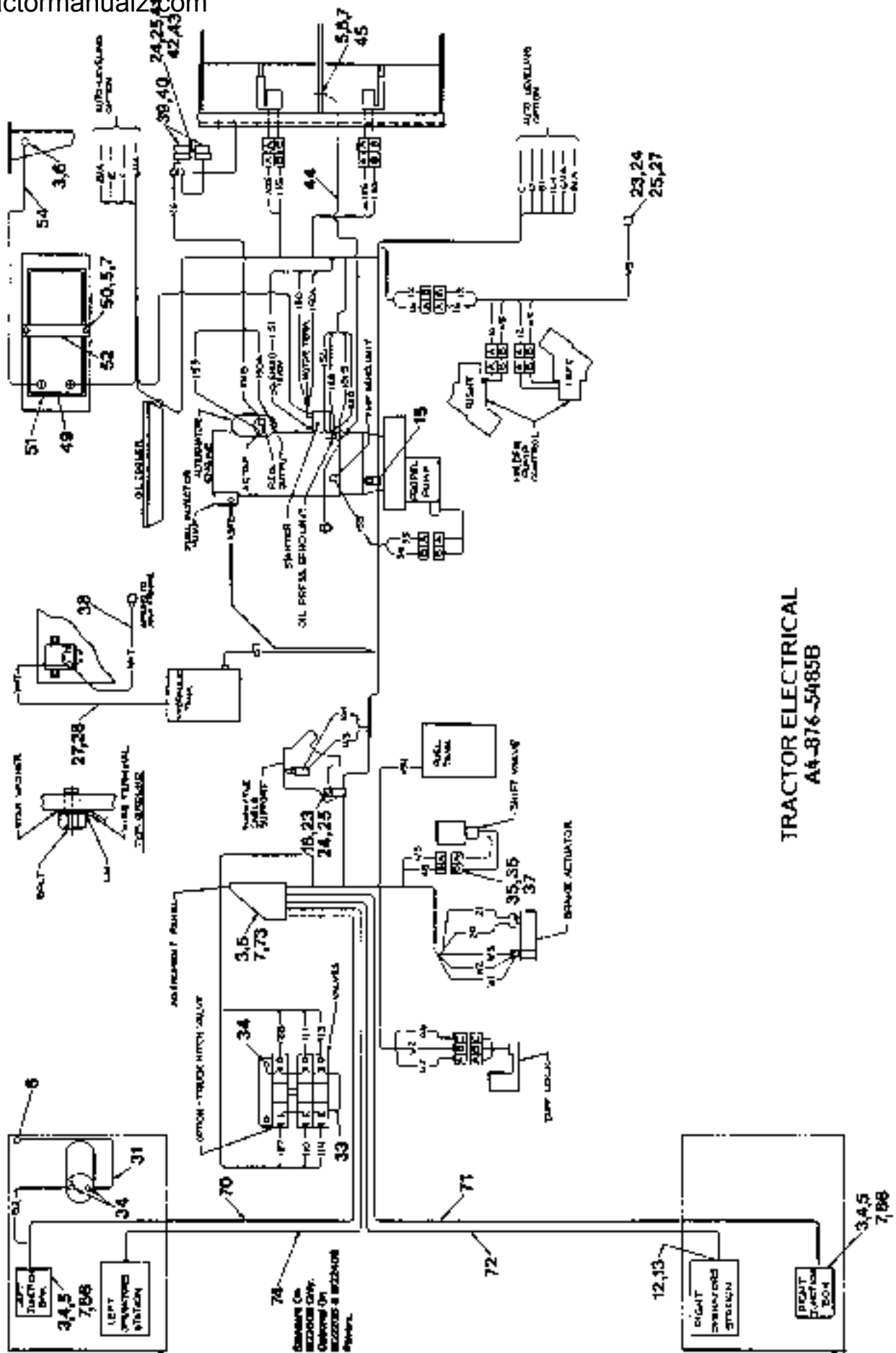

TRACTOR ELECTRICAL
A4-876-5485B

TRACTOR ELECTRICAL

A4-876-5485B

(Before Ordering, Consult Table of Contents to Verify Proper Bill of Material Number.)

REF.	PART NUMBER	QTY.	DESCRIPTION
Ref. #3 thru #73 Symbolized by NONE on Illustration.			
3	26C53	10	3/8" x 1" Hex Head Cap Screw
4	27L56	4	3/8" Cut Washer
5	27L78	13	3/8" Lock Washer
6	26C97	6	3/8" Lock Washer (External Tooth)
7	27C90	18	3/8" Nut
a	28F14	1	Loom, Spiral Wrap x 8"
	BD-876-5488	1	Bar, Support
	28K31	1	Clamp
12	27X59	1	Fitting, Entrance
13	27J60	2	1/4" x 1/2" Round Head Machine Screw
15	28K31	2	Clamp
16	20K39	2	Clamp
	20K34	1	Clamp
	15Y67	1	Clamp
	15Y68	1	Clamp
	13J31	5	1/4" x 3/4" Hex Head Cap Screw
	27C86	4	1/4" Nut
	27L76	5	1/4" Lock Washer
23	26E25	4	5/16" x 3/4" Hex Head Cap Screw
24	27C87	7	5/16" Nut
25	27L77	5	5/16" Lock Washer
	27L52	1	5/16" Lock Washer
27	11E31	2	5/16" Lock Washer (External Tooth)
28	GA-876-5297W	1	Wire, Ground (Hydraulic Tank)
31	GB-876-5287W	1	Wire, Ground (Pump)
33	GA-876-5487W	1	Wire, Ground (Valve Bank)
34	11E30	3	1/4" Lock Washer (External Tooth)
35	28F22	1	Tower (Shift Valve)
36	28F31	2	Terminal, Female (Shift Valve)
37	28F32	2	Seal, Cable (Shift Valve)
38	EL-876-5289W	1	Wire, Ground (Instrument Panel to Mainframe)
39	10W96	1	Horn (Hi-Pitch)
40	10W97	1	Horn (Low Pitch)
41	23V67	1	5/16" x 1" Hex Head Cap Screw
42	27L54	2	5/16" Cut Washer
43	GC-876-5287W	1	Wire, Ground (Horn)
44	14N31	1	Wire, Ground (Engine)
45	10E10	1	3/8" x 1-1/4" Hex Head Cap Screw
47	b	1	Battery, 12 Volt (Wet)
50	A-17-301	2	Rod, Threaded
51	A-876-4693	2	Mat, Rubber
52	DB-876-5288	1	Bar, Hold Down
54	MB-876-5297W	1	Cable, Battery (Negative)

5/1/90 (1-14) (2-13)

SECTION 9 PAGE 6b

(Continued)

REF.	PART NUMBER	QTY.	DESCRIPTION
	10B23	25	Ties, Plastic Wire
	11P81	12	Ties, Plastic Wire
66	10E10	4	3/8" x 1.25" Hex Head Cap Screw
	14Y52	50	Strap, Cable
	AA5-876-5485P	1	Electrical Package (Consisting of the following indented items):
70	XAI-876-5487W	1	. Junction Box (Left Side) (See Section 9 Page 8)
71	XBI-876-5487W	1	. Junction Box (Right Side) (See Section 9 Page 10)
72	VA-876-5487W	1	. Operator's Station Panel & Harness (Right Side) (See Section 9 Page 11)
73	SAI-876-5487W	1	. Instrument Panel & Harness (See Section 9 Page 13b)
	EE-876-5288	2	Shaft, 18.75" (For Feeder Electrical)

a - Be sure to specify length when ordering.
b - Purchase Locally.

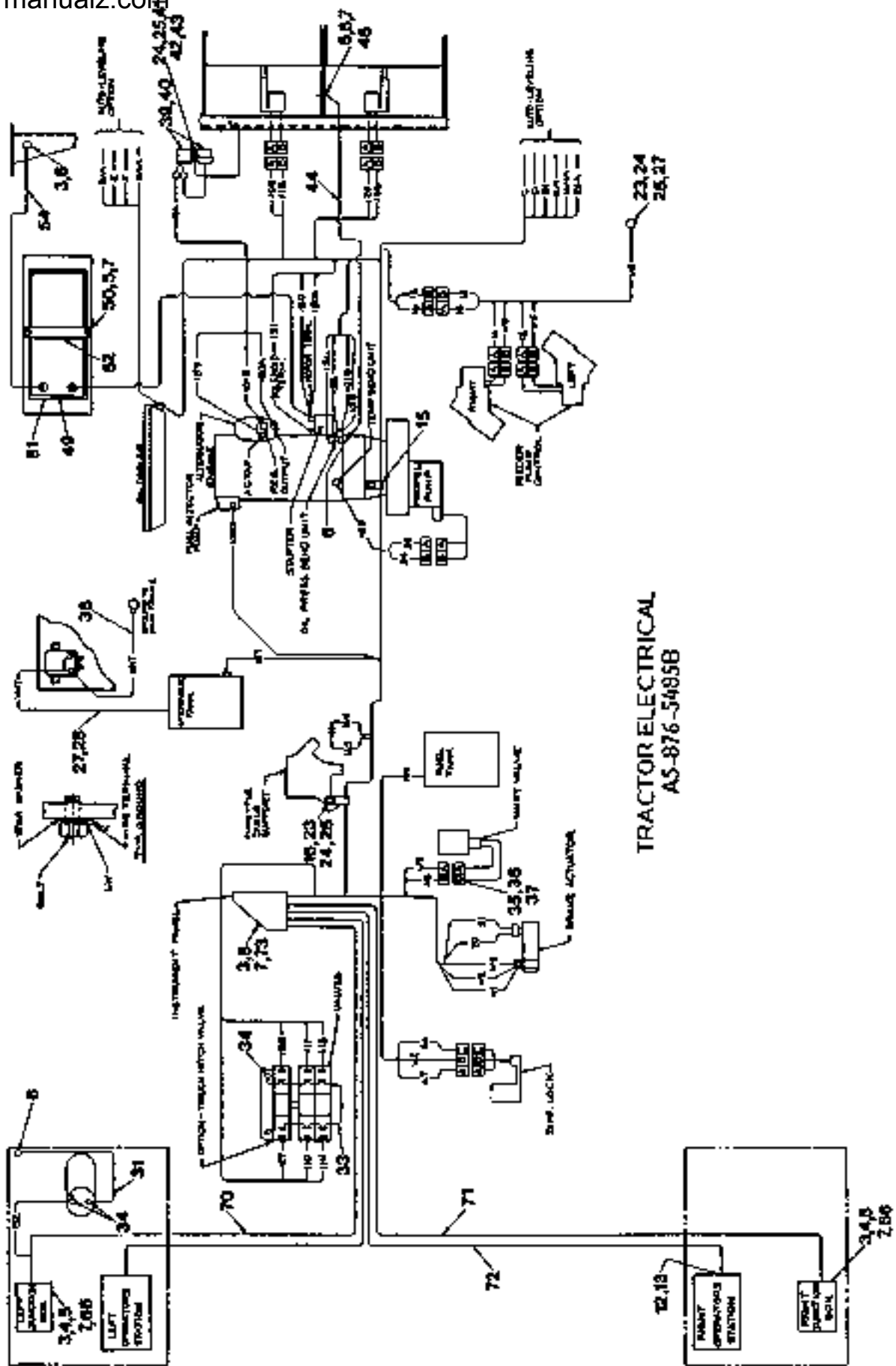

TRACTOR ELECTRICAL

A5-876-5485B

(Before Ordering, Consult Table of Contents to Verify Proper Bill of Material Number.)

REF.	PART NUMBER	QTY.	DESCRIPTION
Ref. #3 thru #73 Symbolized by NONE on Illustration.			
3	26C53	10	3/8" x 1" Hex Head Cap Screw
4	27L56	4	3/8" Cut Washer
5	27L78	13	3/8" Lock Washer
6	26C97	6	3/8" Lock Washer (External Tooth)
7	27C90	18	3/8" Nut
a	28F14	1	Loom, Spiral Wrap x 8"
	BD-876-5488	1	Bar, Support
	28K31	1	Clamp
12	27X59	1	Fitting, Entrance
13	27J60	2	1/4" x 1/2" Round Head Machine Screw
15	28K31	2	Clamp
16	20K38	2	Clamp
	20K34	1	Clamp
	15Y67	1	Clamp
	15Y68	1	Clamp
	13J31	5	1/4" x 3/4" Hex Head Cap Screw
	27C96	4	1/4" Nut
	27L76	5	1/4" Lock Washer
23	26E25	4	5/16" x 3/4" Hex Head Cap Screw
24	27C87	7	5/16" Nut
25	27L77	5	5/16" Lock Washer
	27L52	1	5/16" Lock Washer
27	11E31	2	5/16" Lock Washer (External Tooth)
28	GA-876-5287W	1	Wire, Ground (Hydraulic Tank)
	52Z09	1	Plug, Single Pin
31	GB-876-5287W	1	Wire, Ground (Pump)
33	GA-876-5487W	1	Wire, Ground (Valve Bank)
34	11E30	3	1/4" Lock Washer (External Tooth)
35	28F22	1	Tower (Shift Valve)
36	28F31	2	Terminal, Female (Shift Valve)
37	28F32	2	Seal, Cable (Shift Valve)
38	EL-876-5289W	1	Wire, Ground (Instrument Panel to Mainframe)
39	10W96	1	Horn (Hi-Pitch)
40	10W97	1	Horn (Low Pitch)
41	23V67	1	5/16" x 1" Hex Head Cap Screw
42	27L54	2	5/16" Cut Washer
43	GC-876-5287W	1	Wire, Ground (Horn)
44	14NB1	1	Wire, Ground (Engine)
45	10E10	1	3/8" x 1-1/4" Hex Head Cap Screw
49	b	1	Battery, 12 Volt (Wet)
50	A-17-301	2	Rod, Threaded
51	A-876-4693	2	Mat, Rubber
52	WD-876-5287W	1	Bar, Hold Down

REF.	PART NUMBER	QTY.	DESCRIPTION
54	MB-876-5297W	1	Cable, Battery (Negative)
	10B23	25	Ties, Plastic Wire
	11P81	12	Ties, Plastic Wire
66	10E10	4	3/8" x 1.25" Hex Head Cap Screw
	14Y52	50	Strap, Cable
	AA6-876-5485P	1	Electrical Package (Consisting of the following indented items):
70	XA1-876-5487W	1	. Junction Box (Left Side) (See Section 9 Page 8)
71	XB1-876-5487W	1	. Junction Box (Right Side) (See Section 9 Page 10)
72	VA-876-5487W	1	. Operator's Station Panel & Harness (Right Side) (See Section 9 Page 11)
73	SA2-876-5487W	1	. Instrument Panel & Harness (See Section 9 Page 13d)
	EE-876-5288	2	Shaft, 18.75" (For Feeder Electrical)

- a - Be sure to specify length when ordering.
b - Purchase Locally.

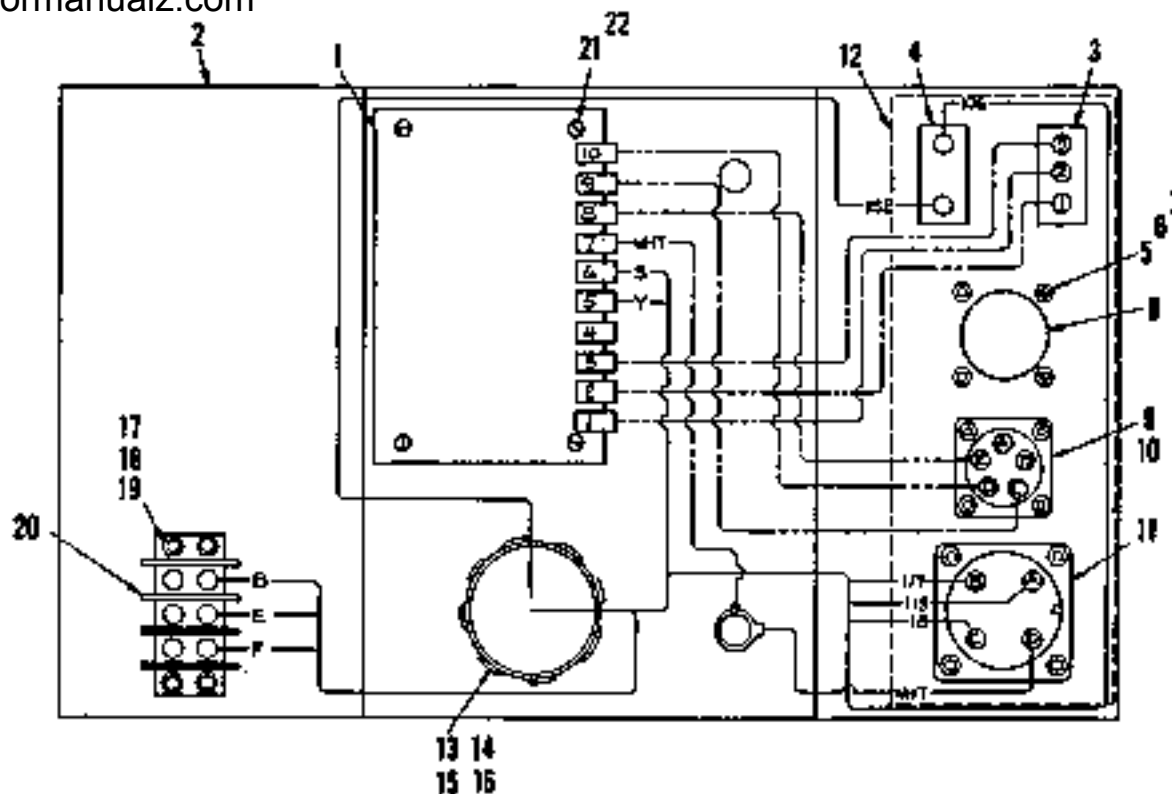

**JUNCTION BOX
(Left Side)**

XA-876-5487W

(From Section 9 Page 3)

(Before Ordering, Consult Table of Contents to Verify Proper Bill of Material Number.)

REF.	PART NUMBER	QTY.	DESCRIPTION
1	28T49	1	Transducer, Angular
2	CA-876-5488	1	Box
3	20P56	1	Switch (Feeder Control) (Hi - Low - Med)
4	20D10	1	Switch (Spray Down Burners)
5	28N63	12	#4-40 x 1/2" Round Head Machine Screw
6	27C71	12	#4-40 Hex Nut
7	27L94	12	#4 Lock Washer
8	28T50	1	Plug, Hole (Auto-Leveling)
9	14F66	1	Receptacle (Feeders)
10	28N62	1	Cap & Chain
11	WB-876-5487W	1	Harness (Screened)
12	A-46-2279	1	Nameplate
13	23S58	1	Grip, Cord
14	20F21	1	Seal, O-Ring
15	20C65	1	Lock Nut
16	23S43	1	Grammet
17	27J86	4	#8-32 x 3/4" Round Head Machine Screw
18	27C77	4	#8-32 Hex Nut
19	27L97	4	#8 Lock Washer
20	14N72	1	Strip, Terminal
21	10P40	4	#10-32 x 3/8" Round Head Machine Screw
22	27L99	4	#10 Lock Washer

2/25/89 (X-3)

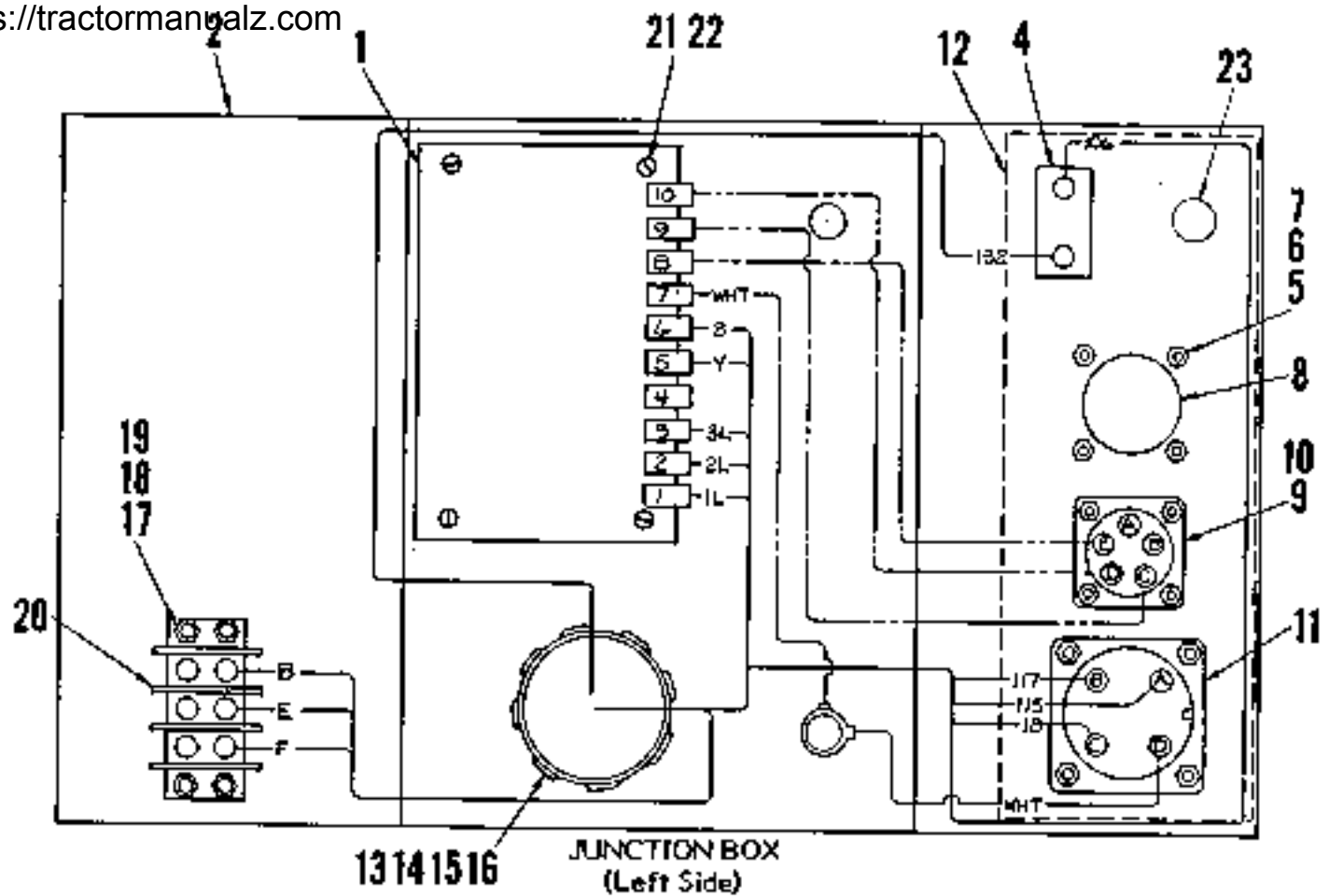

XAF-876-5487W

(From Section 9 Pages 6, 6c & 6f)

(Before Ordering, Consult Table of Contents to Verify Proper Bill of Material Number.)

REF.	PART NUMBER	QTY.	DESCRIPTION
1	28T49	1	Transducer, Angular
2	CA-876-5488	1	Box
4	20D10	1	Switch (Spray Down Burners)
5	28N63	12	#4-40 x 1/2" Round Head Machine Screw
6	27C71	12	#4-40 Hex Nut
7	27L94	12	#4 Lock Washer
8	28T50	1	Plug, Hole (Auto-Leveling)
9	14F66	1	Receptacle (Feeders)
10	28N62	1	Cap & Chain
11	WBI-876-5487W	1	Harness (Screed)
12	A-46-2279	1	Nameplate
13	23S58	1	Grip, Cord
14	20F21	1	Seal, O-Ring
15	20C65	1	Lock Nut
16	23S43	1	Grommet
17	27JB6	4	#8-32 x 3/4" Round Head Machine Screw
18	27C77	4	#8-32 Hex Nut
19	27L97	4	#8 Lock Washer
20	14N72	1	Strip, Terminal
21	10P40	4	#10-32 x 3/8" Round Head Machine Screw
22	27L99	4	#10 Lock Washer
23	20DB5	1	Plug, Hole

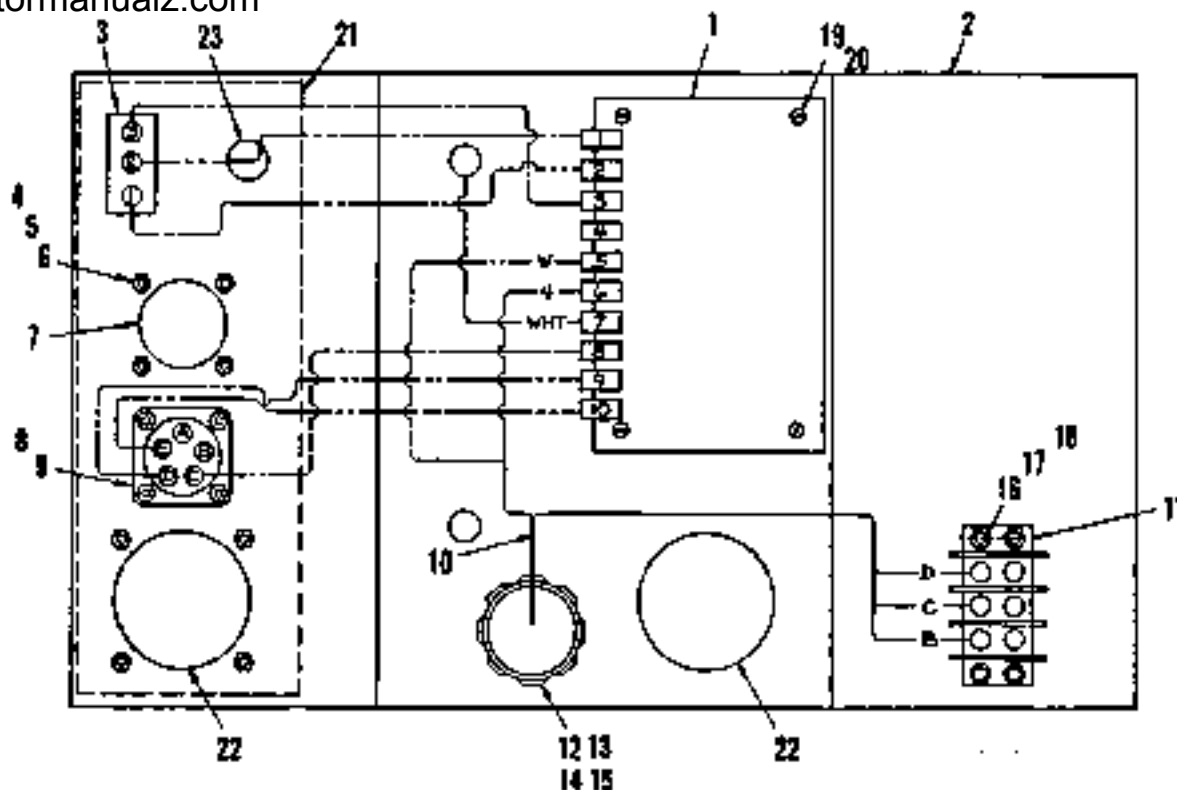

**JUNCTION BOX
(Right Side)**

XB-876-5487W

(From Section 9 Page 3)

(Before Ordering, Consult Table of Contents to Verify Proper Bill of Material Number.)

REF.	PART NUMBER	QTY.	DESCRIPTION
1	28T49	1	Transducer, Angular
2	CB-876-5488	1	Box
3	20P56	1	Switch (Feeder Control) (Hi - Low - Med)
4	28N63	12	#4-40 x 1/2" Round Head Machine Screw
5	27C71	12	#4-40 Hex Nut
6	27L94	12	#4 Lock Washer
7	28T50	1	Plug, Hole (Auto-Leveling)
8	14F66	1	Receptacle (Feeders)
9	28N62	1	Cap & Chain
10	WA-876-5487W	1	Harness (Accessories)
11	14N72	1	Strip, Terminal
12	23S41	1	Grip, Cord
13	20F19	1	Seal, O-Ring
14	20C63	1	Lock Nut
15	23S28	1	Grommet
16	27J86	4	#8-32 x 3/4" Round Head Machine Screw
17	27C77	4	#8-32 Hex Nut
18	27L97	4	#8 Lock Washer
19	27L99	4	#10 Lock Washer
20	10P40	4	#10-32 x 3/8" Round Head Machine Screw
21	B-46-2279	1	Nameplate
22	28W77	2	Plug, Hole (Accessories)
23	20D85	1	Plug, Hole

2/25/89 (X-3)

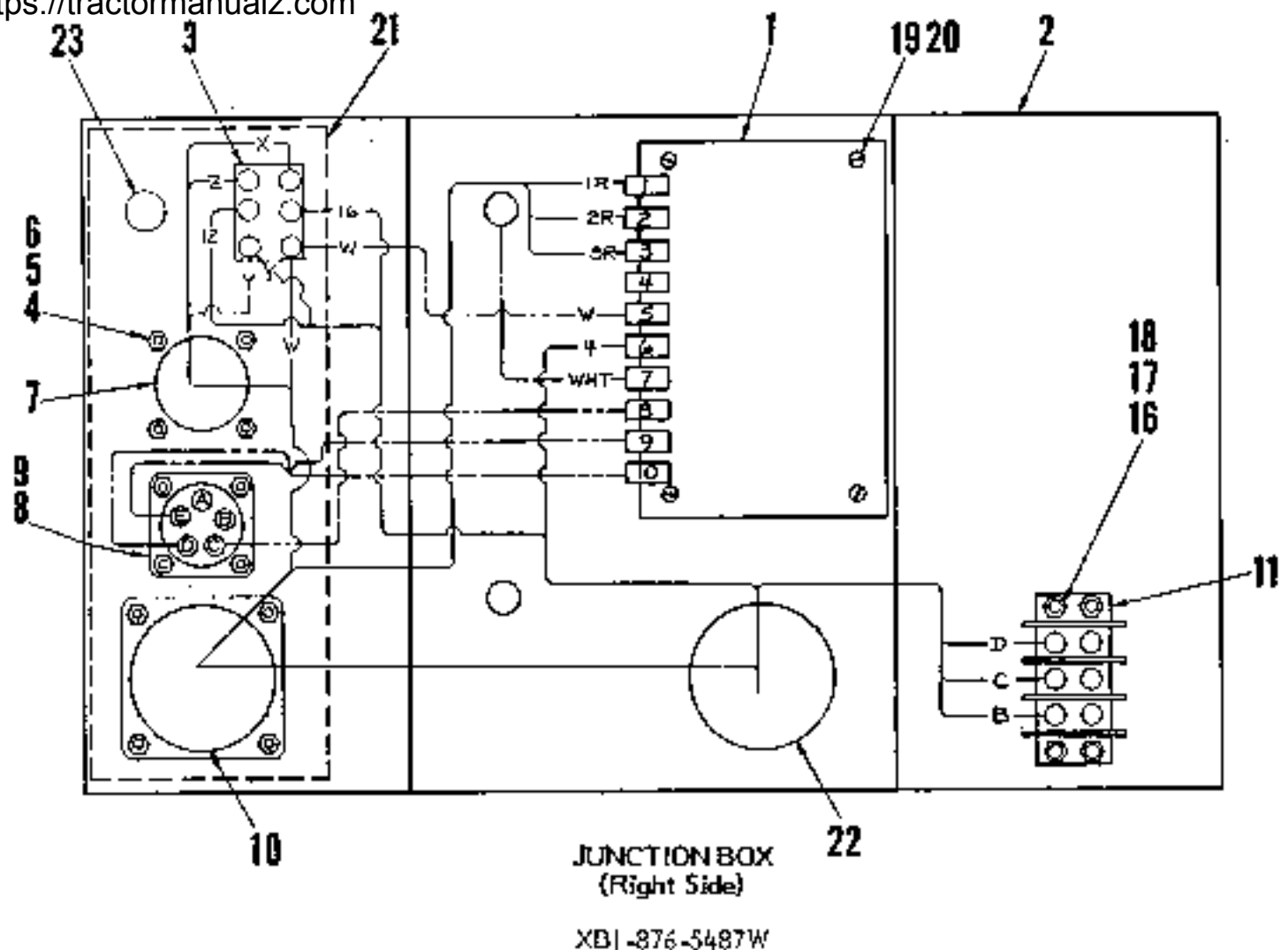

(From Section 9 Pages 6, 6c & 6f)
(Before Ordering, Consult Table of Contents to Verify Proper Bill of Material Number.)

REF.	PART NUMBER	QTY.	DESCRIPTION
1	28T49	1	Transducer, Angular
2	CBI-876-5488	1	Box
3	12S97	1	Switch (Feeder Control) (Tractor or Sereed)
4	28N63	12	#4-40 x 1/2" Round Head Machine Screw
5	27C71	12	#4-40 Hex Nut
6	27L94	12	#4 Lock Washer
7	28T50	1	Plug, Hole (Auto-Leveling)
8	14F66	1	Receptacle (Feeders)
9	28N62	1	Cap & Chain
10	EAI-876-3642W	1	Harness (Accessories)
11	14N72	1	Strip, Terminal
16	27J86	4	#8-32 x 3/4" Round Head Machine Screw
17	27C77	4	#8-32 Hex Nut
18	27L97	4	#8 Lock Washer
19	27L99	4	#10 Lock Washer
20	10P40	4	#10-32 x 3/8" Round Head Machine Screw
21	B-46-2279	1	Nameplate
22	27X59	1	Fitting, Cable
23	20D85	1	Plug, Hole

8/20/91 (X-4)

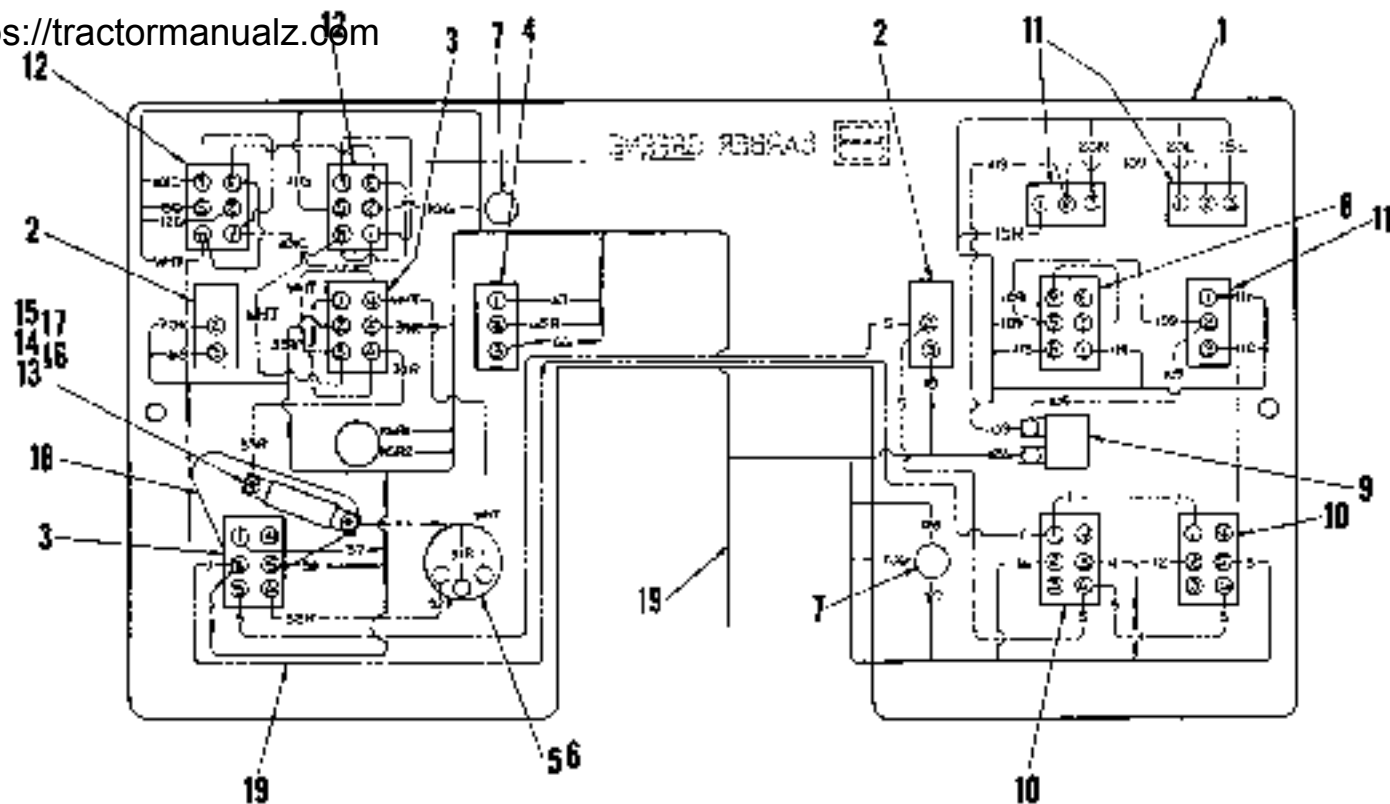

**OPERATOR'S STATION PANEL & HARNESS
(Right Side)**

VA-876-5487W

(From Section 9 Pages 3, 6, 6c & 6f)

(Before Ordering, Consult Table of Contents to Verify Proper Bill of Material Number.)

REF.	PART NUMBER	QTY.	DESCRIPTION
1	A-46-2273	1	Panel
2	20P60	2	Switch (Screed Drive) (Shift)
3	12S97	2	Switch (Forward - Reverse) (Start - Stop)
4	28F18	1	Switch (Differential Lock)
5	13R32	1	Potentiometer, 50 OHM, 25 W. (Speed Control)
6	13R33	1	Knob (Speed Control)
7	14R68	2	Plug, Hole (Truck Hitch) (Four-Wheel Drive)
8	13P15	1	Switch (Screed Lift)
9	13M55	1	Switch, Push Button (Horn)
10	13P42	2	Switch (Feeder - Left & Right - Auto or Manual)
11	20P55	3	Switch (Hopper) (Screed Extenders - Left & Right)
12	13D25	2	Switch (Feeder Gate - Left & Right)
13	28M41	2	#4-40 x 3/8" Flat Head Machine Screw
14	27C71	2	#4-40 Hex Nut
15	27L94	2	#4 Lock Washer
16	38Z94	1	Resistor, 100 OHM, 8 W.
17	35Z88	2	Clip, Mounting
18	BA-876-5488	1	Plate, Resistor
19	ZA-876-5487W	1	Harness
	Purchase Locally	o	Tie, Plastic Wire
	Purchase Locally	a	Wire, Jumper

a - Order as required.

INSTRUMENT PANEL & HARNESS
SA-876-5487W

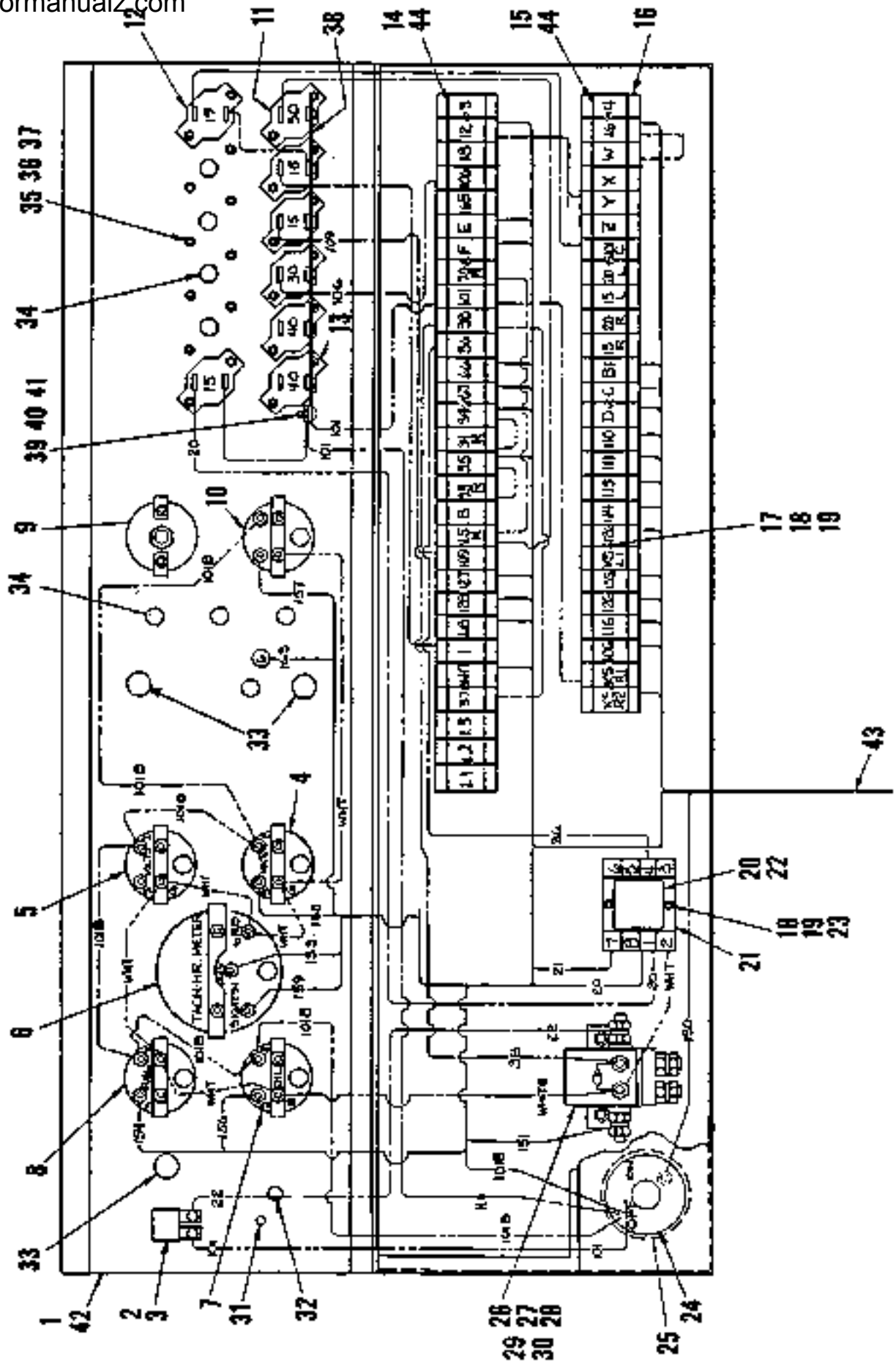

INSTRUMENT PANEL & HARNESS

SA-876-5487W

(From Section 9 Pages 3 & 6)

(Before Ordering, Consult Table of Contents to Verify Proper Bill of Material Number.)

REF.	PART NUMBER	QTY.	DESCRIPTION
Ref. #1 thru #44 Symbolized by NONE on Illustration.			
1	RA-876-5487W	1	Box, Electrical
2	13M55	1	Button, Starter
3	28F17	1	Cap, Black Rubber
4	27T21	1	Gauge (Water Temperature)
5	27V35	1	Gauge (Volt)
6	27T41	1	Meter (Tach - Hour)
7	27T20	1	Gauge (Oil Pressure)
8	27T43	1	Gauge (Fuel)
9	16T34	1	Gauge (Hydraulic Filter Condition)
10	27T22	1	Gauge (Hydraulic Oil Temperature)
11	13A05	2	Breaker, Circuit (30 Amp.)
12	13A04	4	Breaker, Circuit (15 Amp.)
13	13A06	2	Breaker, Circuit (40 Amp.)
14	C-46-2281	1	Nameplate
15	A-46-2281	1	Nameplate
16	13C69	55	Block, Terminal
17	27J78	10	#6-32 x 3/4" Round Head Machine Screw
18	27C75	14	#6-32 Hex Nut
19	27N69	12	#6 Lock Washer
20	13Z96	1	Relay
21	20P12	1	Socket, Relay
22	51Z81	1	Spring, Relay Socket
23	20Z21	2	#6-32 x 1-1/4" Round Head Machine Screw
24	28T39	1	Nameplate
25	28T38	1	Switch (Main Power)
26	26N72	1	Solenoid
27	11F13	1	Diode
28	26L55	2	1/4" x 5/8" Hex Head Cap Screw
29	27L76	2	1/4" Lock Washer
30	27C86	2	1/4" Nut
31	28T41	1	Plug, 1/4" Hole
32	14R69	1	Plug, 3/8" Hole
33	28T43	3	Plug, 11/16" Hole
34	14R68	8	Plug, 1/2" Hole
35	27J99	24	#10-24 x 3/4" Round Head Machine Screw
36	27C78	24	#10-24 Hex Nut
37	27L98	24	#10 Lock Washer
38	DE-876-5288	1	Bar, Buss
39	27J60	1	1/4" x 1/2" Round Head Machine Screw
40	27C86	1	1/4" Nut
41	27L76	1	1/4" Lock Washer
42	A-46-2276	1	Overlay, Panel
43	A-876-5489W	1	Harness
44	28W78	11	#2-56 x .25" Round Head Self Tapping Screw
	28Y31	1	Keys

INSTRUMENT PANEL & HARNESS
SAI-876-5487W

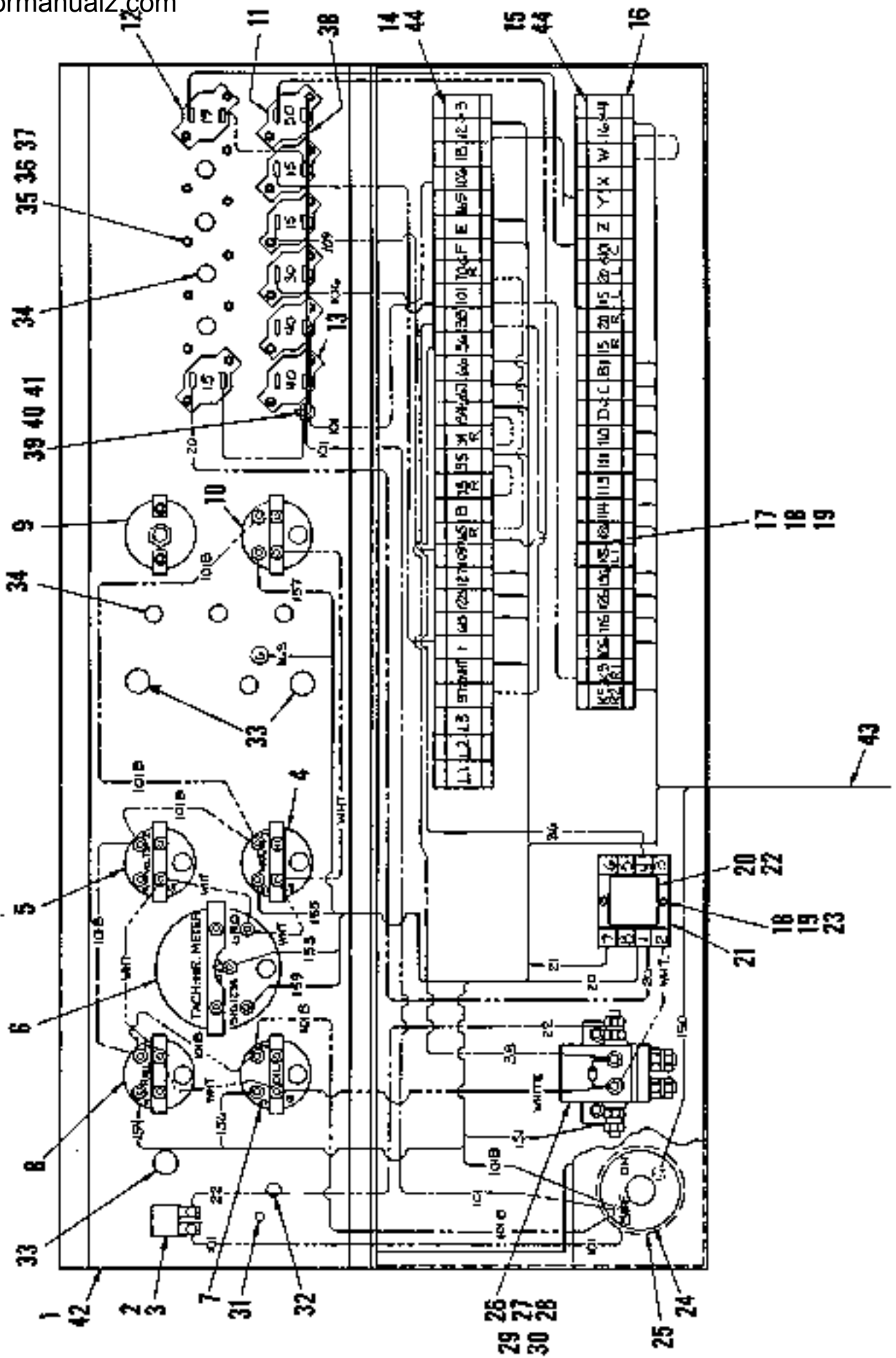

INSTRUMENT PANEL & HARNESS

SA1-876-5487W

(From Section 9 Page 6c)

(Before Ordering, Consult Table of Contents to Verify Proper Bill of Material Number.)

REF.	PART NUMBER	QTY.	DESCRIPTION
Ref. #1 thru #44 Symbolized by NONE on Illustration.			
1	RA-876-5487W	1	Box, Electrical
2	13M55	1	Button, Starter
3	28F17	1	Cap, Black Rubber
4	27T21	1	Gauge (Water Temperature)
5	27V35	1	Gauge (Volt)
6	27T41	1	Meter (Tach - Hour)
7	27T20	1	Gauge (Oil Pressure)
8	27T43	1	Gauge (Fuel)
9	16T34	1	Gauge (Hydraulic Filter Condition)
10	27T22	1	Gauge (Hydraulic Oil Temperature)
11	13A05	2	Breaker, Circuit (30 Amp.)
12	13A04	4	Breaker, Circuit (15 Amp.)
13	13A06	2	Breaker, Circuit (40 Amp.)
14	C-46-2281	1	Nameplate
15	A-46-2281	1	Nameplate
16	13C69	55	Block, Terminal
17	27J78	10	#6-32 x 3/4" Round Head Machine Screw
18	27C75	14	#6-32 Hex Nut
19	27N69	12	#6 Lock Washer
20	13Z96	1	Relay
21	20P12	1	Socket, Relay
22	51Z81	1	Spring, Relay Socket
23	20Z21	2	#6-32 x 1-1/4" Round Head Machine Screw
24	28T39	1	Nameplate
25	28T38	1	Switch (Main Power)
26	26N72	1	Solenoid
27	11F13	1	Diode
28	26L55	2	1/4" x 5/8" Hex Head Cap Screw
29	27L76	2	1/4" Lock Washer
30	27C86	2	1/4" Nut
31	28T41	1	Plug, 1/4" Hole
32	14R69	1	Plug, 3/8" Hole
33	28T43	3	Plug, 11/16" Hole
34	14R68	8	Plug, 1/2" Hole
35	27J99	24	#10-24 x 3/4" Round Head Machine Screw
36	27C78	24	#10-24 Hex Nut
37	27L98	24	#10 Lock Washer
38	DE-876-5288	1	Bar, Buss
39	27J60	1	1/4" x 1/2" Round Head Machine Screw
40	27C86	1	1/4" Nut
41	27L76	1	1/4" Lock Washer
42	A-46-2276	1	Overlay, Panel
43	A1-876-5489W	1	Harness
44	28W78	11	#2-56 x .25" Round Head Self Tapping Screw
	28Y31	1	Keys

INSTRUMENT PANEL & HARNESS
SA2-876-5187W

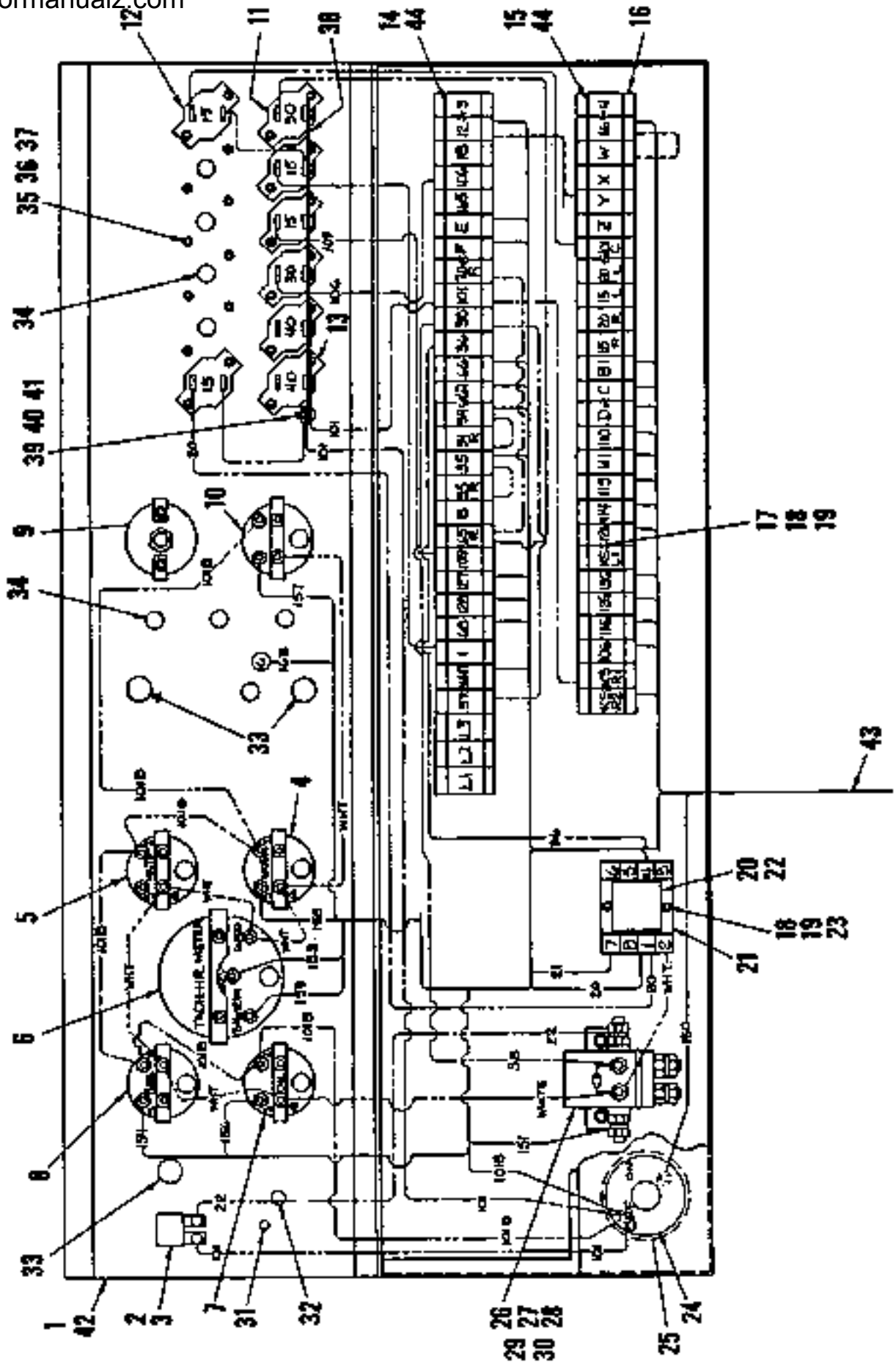

INSTRUMENT PANEL & HARNESS

SA2-876-5487W

(From Section 9 Page 6f)

(Before Ordering, Consult Table of Contents to Verify Proper Bill of Material Number.)

REF.	PART NUMBER	QTY.	DESCRIPTION
Ref. #1 thru #44 Symbolized by NONE on Illustration.			
1	RA-876-5487W	1	Box, Electrical
2	13M55	1	Button, Starter
3	28F17	1	Cap, Black Rubber
4	27T21	1	Gauge (Water Temperature)
5	27V35	1	Gauge (Volt)
6	27T41	1	Meter (Tach - Hour)
7	27T20	1	Gauge (Oil Pressure)
8	27T43	1	Gauge (Fuel)
9	16T34	1	Gauge (Hydraulic Filter Condition)
10	32A55	1	Gauge (Hydraulic Oil Temperature)
11	13A05	2	Breaker, Circuit (30 Amp.)
12	13A04	4	Breaker, Circuit (15 Amp.)
13	13A06	2	Breaker, Circuit (40 Amp.)
14	C-46-2281	1	Nameplate
15	A-46-2281	1	Nameplate
16	13C69	55	Block, Terminal
17	27J79	10	#6-32 x 3/4" Round Head Machine Screw
18	27C75	14	#6-32 Hex Nut
19	27N69	12	#6 Lock Washer
20	13Z96	1	Relay
21	20P12	1	Socket, Relay
22	51Z81	1	Spring, Relay Socket
23	20Z21	2	#6-32 x 1-1/4" Round Head Machine Screw
24	28T39	1	Nameplate
25	28T38	1	Switch (Main Power)
26	26N72	1	Solenoid
27	11F13	1	Diode
28	26L55	2	1/4" x 5/8" Hex Head Cap Screw
29	27L76	2	1/4" Lock Washer
30	27C86	2	1/4" Nut
31	28T41	1	Plug, 1/4" Hole
32	14R69	1	Plug, 3/8" Hole
33	28T43	3	Plug, 11/16" Hole
34	14R68	8	Plug, 1/2" Hole
35	27J99	24	#10-24 x 3/4" Round Head Machine Screw
36	27C78	24	#10-24 Hex Nut
37	27L98	24	#10 Lock Washer
38	DE-876-5288	1	Bar, Buss
39	27J60	1	1/4" x 1/2" Round Head Machine Screw
40	27C86	1	1/4" Nut
41	27L76	1	1/4" Lock Washer
42	A-46-2276	1	Overlay, Panel
43	A1-876-5489W	1	Harness
44	28W78	11	#2-56 x .25" Round Head Self Tapping Screw
	28Y31	1	Keys

**OPTIONAL LEFT SIDE OPERATORS STATION PANEL & HARNESS
(With John Deere Power Unit)**

BI-876-5485B

(Before Ordering, Consult Table of Contents to Verify Proper Bill of Material Number.)

REF.	PART NUMBER	QTY.	DESCRIPTION
	TA-876-5487W	1	Operators Station Panel & Harness (Left Side) (See Section 9 Page 15)
	27J60	2	1/4" x 1/2" Round Head Machine Screw
	27X59	1	Fitting, Entrance
	12X06	1	Switch (Engine Stop) (John Deere) (Mounted on Optional Operators Station Panel)

**OPTIONAL LEFT SIDE OPERATORS STATION PANEL & HARNESS
(With G.M.C. Power Unit)**

CI-876-5485B

(Before Ordering, Consult Table of Contents to Verify Proper Bill of Material Number.)

REF.	PART NUMBER	QTY.	DESCRIPTION
	TA-876-5487W	1	Operators Station Panel & Harness (Left Side) (See Section 9 Page 15)
	27J60	2	1/4" x 1/2" Round Head Machine Screw
	27X59	1	Fitting, Entrance
	13M55	1	Switch (Engine Stop) (G.M.C.) (Mounted on Optional Operators Station Panel)

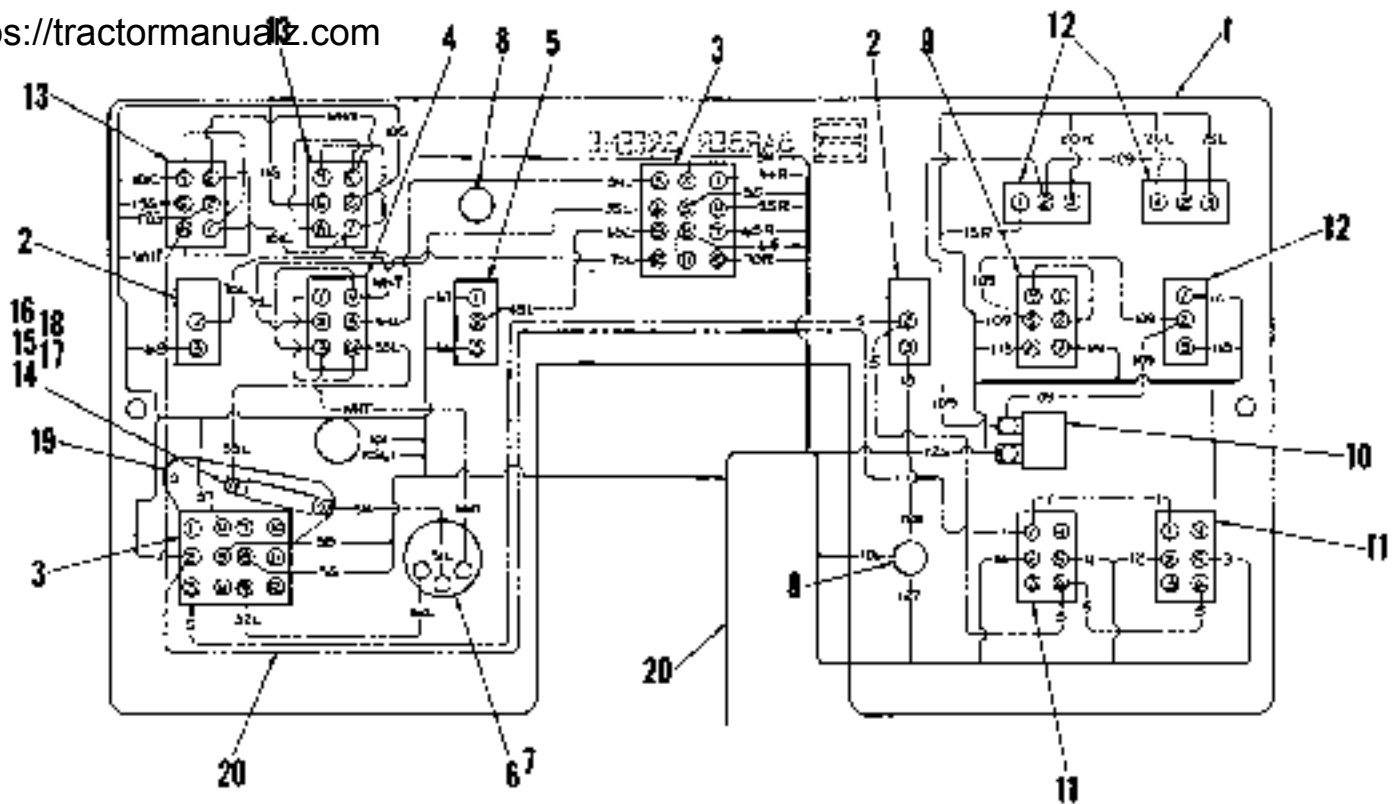

OPERATORS STATION PANEL & HARNESS
(Left Side)

1A-876-5487W

(From Section 9 Page 14)

(Before Ordering, Consult Table of Contents to Verify Proper Bill of Material Number.)

REF.	PART NUMBER	QTY.	DESCRIPTION
1	A-46-2272	1	Panel
2	20P60	2	Switch (Screed Drive) (Shift)
3	20Z53	2	Switch (Station Selector - Left or Right) (Start - Stop)
4	12S97	1	Switch (Forward - Reverse)
5	28F18	1	Switch (Differential Lock)
6	13R32	1	Potentiometer, 50 OHM, 25 W. (Speed Control)
7	13R33	1	Knob (Speed Control)
8	14R68	2	Plug, Mole (Truck Hitch) (Four-Wheel Drive)
9	13P15	1	Switch (Screed Lift)
10	13M55	1	Switch, Push Button (Horn)
11	13P42	2	Switch (Feeder - Right & Left - Auto or Manual)
12	20P55	3	Switch (Hopper) (Screed Extenders - Left & Right)
13	13D25	2	Switch (Feeder Gate - Left & Right)
14	28M44	2	#4-40 x 3/8" Flat Head Machine Screw
15	27C71	2	#4-40 Hex Nut
16	27L94	2	#4 Lock Washer
17	38Z94	1	Resistor, 100 OHM, 9 W.
18	35Z88	2	Clip, Mounting
19	BA-876-5488	1	Plate, Resistor
20	YA-876-5487W	1	Harness
	Purchase Locally	a	Tie, Plastic Wire
	Purchase Locally	a	Wire, Jumper

a - Order as required.

AUTOMATIC GRADE CONTROL ELECTRICAL
BI-876-5285B

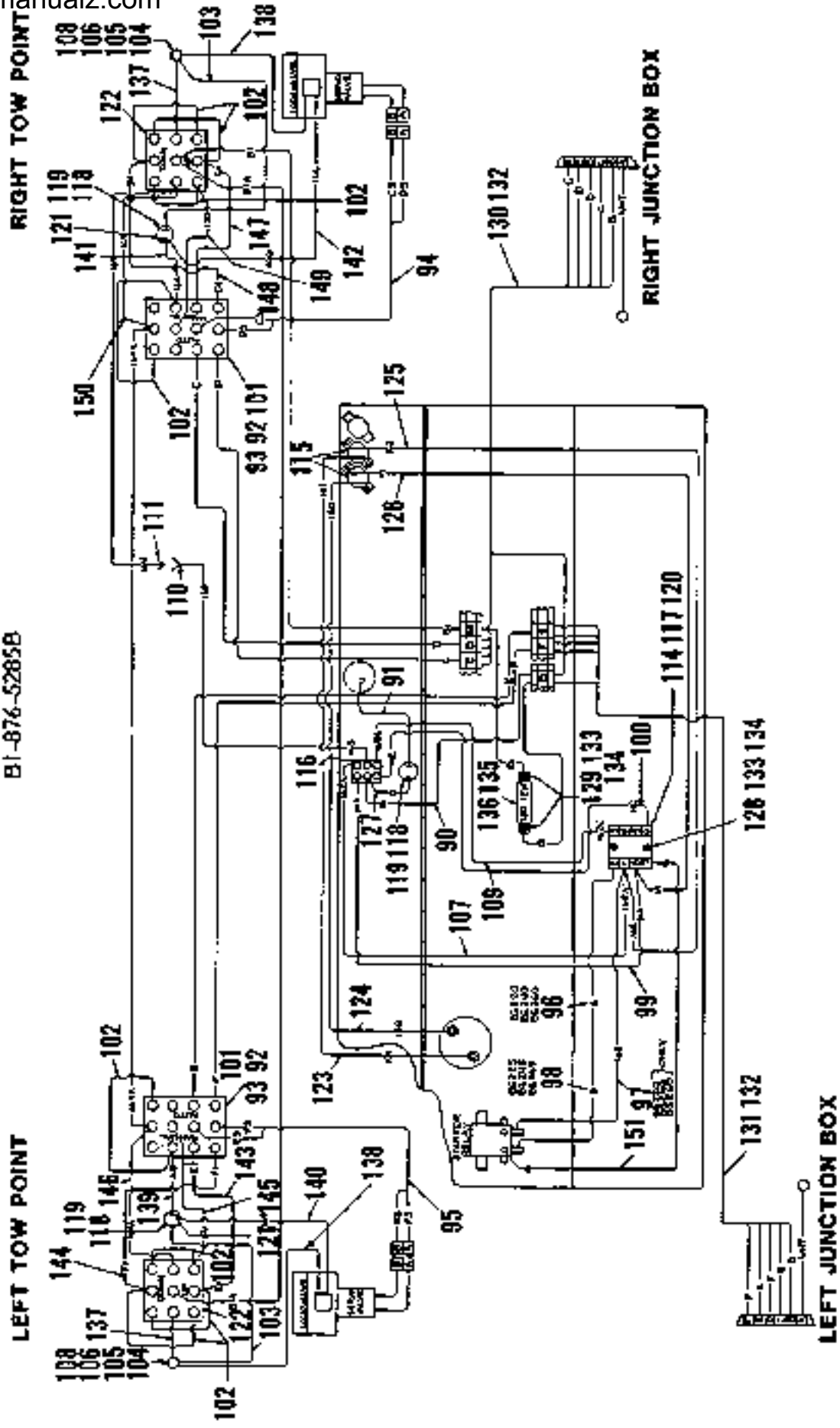

AUTOMATIC GRADE CONTROL ELECTRICAL

91-876-5285B

(Before Ordering, Consult Table of Contents to Verify Proper Bill of Material Number.)

REF.	PART NUMBER	QTY.	DESCRIPTION
Ref. #90 thru #151 Symbolized by NONE on Illustration.			
90	DY-876-5289W	1	Wire (B)
91	GN-876-5287W	1	Wire, Ground
92	HA-876-5288	2	Bracket, Selector (Auto Grade Control)
93	A-46-2284	2	Nameplate, Selector (Auto Grade Control)
94	XF-876-5287W	1	Harness, Servo
95	XG-876-5287W	1	Harness, Servo
96	DW-876-5289W	1	Wire (6) (BG220B, BG240B & BG260B)
97	DV-876-5289W	1	Wire (162)
98	DN-876-5289W	1	Wire (5) (BG225B, BG245B & BG265B)
99	HL-876-5287W	1	Wire (MA)
100	HN-876-5287W	1	Wire (MC)
101	20Z53	2	Switch, Toggle
102	GD-876-5287W	8	Wire, Jumper
103	GE-876-5287W	2	Wire, Ground
104	14L87	2	5/16" x 5/8" Hex Head Cap Screw
105	27C87	2	5/16" Nut
106	27L77	2	5/16" Lock Washer
107	HP-876-5287W	1	Wire (162A)
108	11E31	2	5/16" External Tooth Lock Washer
109	HS-876-5287W	1	Wire (162C)
110	38Z56	1	Terminal, Female, Slip-On - .250" Tab
111	38Z57	1	Terminal, Male, Slip-On - .250" Tab
114	28T02	1	Relay, Timed Delay
115	13R49	2	Breaker, Circuit (8 Amp.)
116	20W78	1	Switch, Toggle (Auto Leveling)
117	28T03	1	Base, Relay
118	15M25	3	Light (Socket & Lens) (Amber)
119	10F89	3	Bulb
120	28T04	1	Strap, Relay
121	33Z07	2	Terminal, Adaptor
122	20Z52	2	Switch, Toggle
123	DA-876-5289W	1	Wire (101)
124	DB-876-5289W	1	Wire (150)
125	DC-876-5289W	1	Wire (162)
126	DD-876-5289W	1	Wire (M)
127	HF-876-5287W	1	Wire (B)
128	27J81	2	#6-32 x 1" Round Head Machine Screw
129	27J76	2	#6-32 x .50" Round Head Machine Screw
130	LD-876-5287W	1	Receptacle & Harness (R.H.)
131	LE-876-5287W	1	Receptacle & Harness (L.H.)
132	20L53	2	Cap & Chain
133	27N69	4	#6 Lock Washer
134	27C75	4	#6 Nut

REF.	PART NUMBER	QTY.	DESCRIPTION
135	LF-876-5287W	1	Resistor & Harness
136	35Z88	2	Clip, Mounting (Resistor)
137	CP-876-5287W	2	Wire, Ground
138	CR-876-5287W	2	Wire, Ground
139	DR-876-5289W	1	Wire (169)
140	DT-876-5289W	1	Wire (169)
141	DP-876-5289W	1	Wire (166)
142	DS-876-5289W	1	Wire (166)
143	DJ-876-5289W	1	Wire (E1)
144	DK-876-5289W	1	Wire (F1)
145	DL-876-5289W	1	Wire (171)
146	DM-876-5289W	1	Wire (164A)
147	DE-876-5289W	1	Wire (C1)
148	DF-876-5289W	1	Wire (D1)
149	DC-876-5289W	1	Wire (170)
150	DH-876-5289W	1	Wire (164)
151	CS-876-5287W	1	Wire, Ground

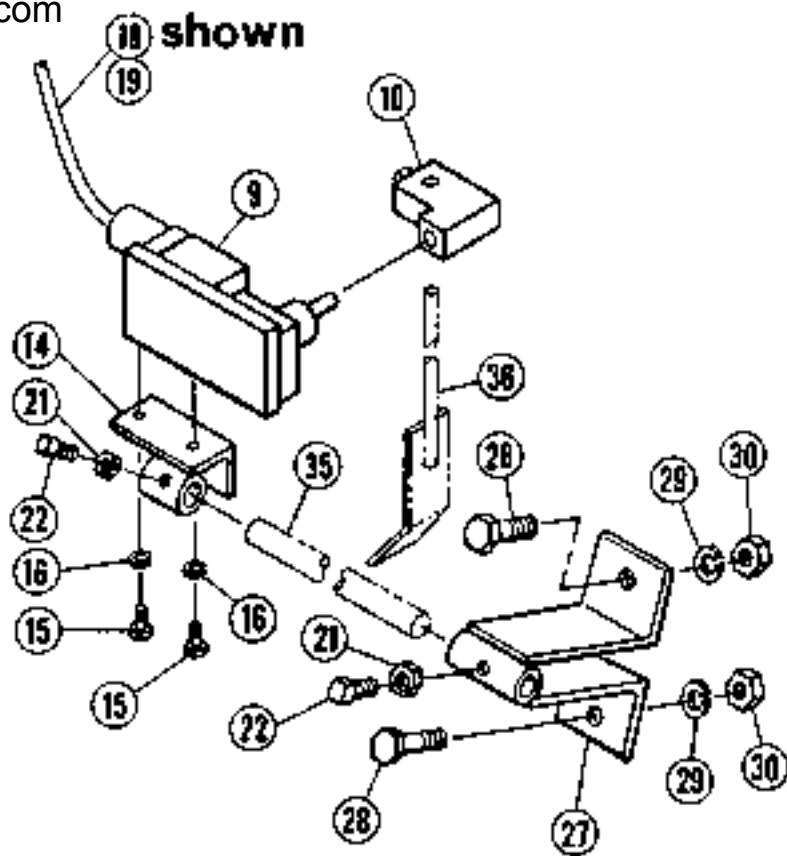

**FEEDER ELECTRICAL
(On / Off)**

C2-876-5285B

(Before Ordering, Consult Table of Contents to Verify Proper Bill of Material Number.)

REF.	PART NUMBER	QTY.	DESCRIPTION
	YA-876-5287W	1	Harness (Feeder Pump)
9	10C95	2	Switch (Feeder Paddle)
10	10C94	2	Lever, Hub
14	F-876-3977W	2	Bracket
15	I3J28	4	1/4" x 1/2" Hex Head Cap Screw
16	27L76	4	1/4" Lock Washer
18	NA-876-5287W	1	Cord, Coil (Left Hand Feeder Switch)
19	NB-876-5287W	1	Cord, Coil (Right Hand Feeder Switch)
21	27D17	4	3/8" Jam Nut
22	27K29	4	3/8" x 3/4" Square Head Set Screw
27	WCI-876-5287W	2	Support
28	26C48	4	5/8" x 1.50" Hex Head Cap Screw
29	27L84	4	5/8" Lock Washer
30	27C98	4	5/8" Nut
35	a	2	Shaft
36	b	2	Paddle, Feeder Switch

a - See Tractor Electrical Bill of Material For Shaft Part Number.

b - See Tools & Spares Bill of Material For Feeder Switch Paddle Part Number.

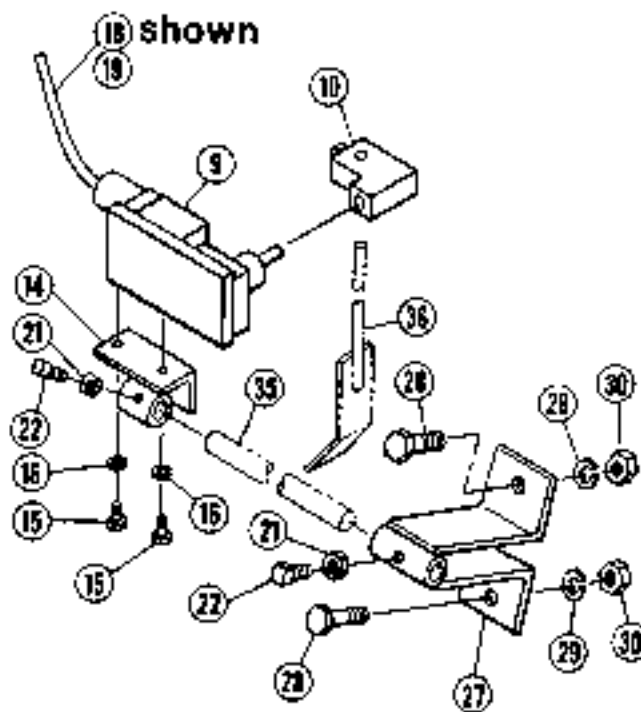

**FEEDER ELECTRICAL
(On / Off)**

C3-876-5285B

(Before Ordering, Consult Table of Contents to Verify Proper Bill of Material Number.)

REF.	PART NUMBER	QTY.	DESCRIPTION
	YA-876-5287W	1	Harness (Feeder Pump)
9	10C95	2	Switch (Feeder Paddle)
10	10C94	2	Lever, Hub
14	F-876-3977W	2	Bracket
15	13J28	4	1/4" x 1/2" Hex Head Cap Screw
16	27L76	4	1/4" Lock Washer
18	NA-876-5287W	1	Coil, Coil (Left Hand Feeder Switch)
19	NB-876-5287W	1	Coil, Coil (Right Hand Feeder Switch)
21	27D17	4	3/8" Jam Nut
22	27K29	4	3/8" x 3/4" Square Head Set Screw
27	WC1-876-5287W	2	Support
28	26C48	4	5/8" x 1.50" Hex Head Cap Screw
29	27L84	4	5/8" Lock Washer
30	27C98	4	5/8" Nut
	HB-876-5487W	1	Harness, Feeder (Right Side)
	HC-876-5487W	1	Harness, Feeder (Left Side)
	28T49	2	Transducer, Angular
	20D85	2	Plug, Hole
35	a	2	Shaft
36	b	2	Paddle, Feeder Switch

a - See Tractor Electrical Bill of Material For Shaft Part Number.

b - See Tools & Spares Bill of Material For Feeder Switch Paddle Part Number.

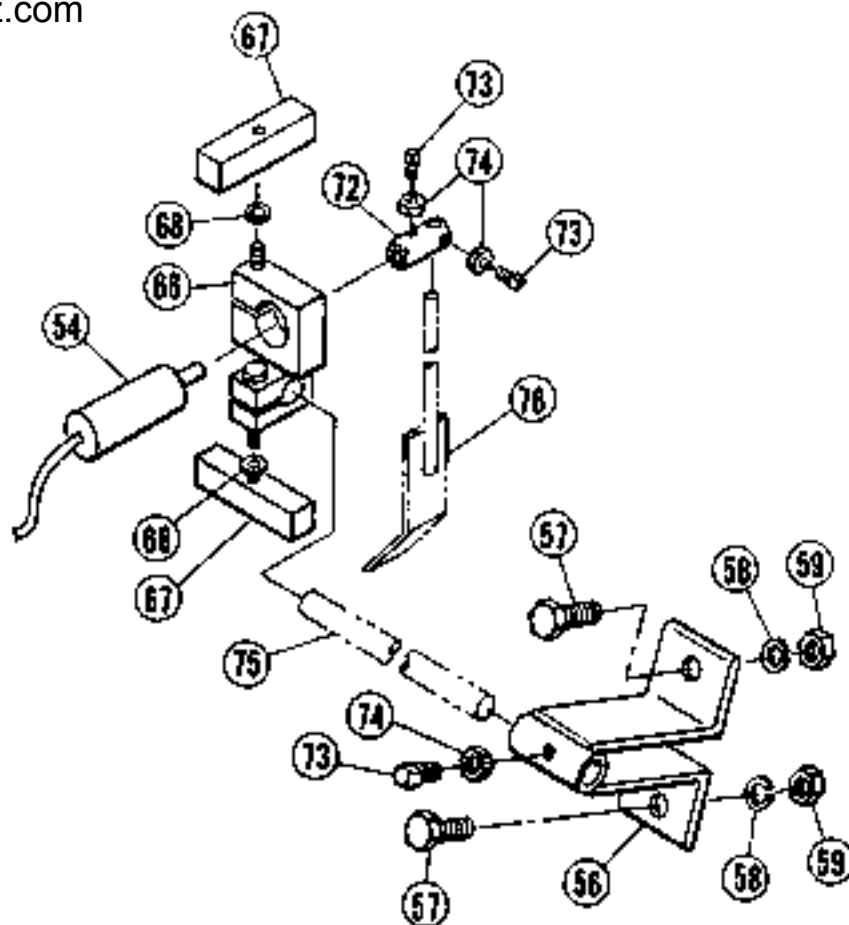

**FEEDER ELECTRICAL
(Proportional)**

DZ-876-5285B

(Before Ordering, Consult Table of Contents to Verify Proper Bill of Material Number.)

REF.	PART NUMBER	QTY.	DESCRIPTION
	YA-876-5287W	1	Harness (Feeder Pump)
54	Z8W34	2	Potentiometer, Feeder
56	WC1-876-5287W	2	Support
57	Z6C48	4	5/8" x 1.50" Hex Head Cap Screw
58	Z7L84	4	5/8" Lock Washer
59	Z7C98	4	5/8" Nut
66	WB-876-5287W	2	Bracket
67	GC-876-5288	4	Handle
68	Z7L56	4	3/8" Cut Washer
72	A-876-1928	?	Adaptor
73	Z7K29	6	3/8" x .75" Square Head Set Screw
74	Z7D17	6	3/8" Jam Nut
75	a	2	Shaft
76	b	2	Paddle, Feeder Switch

a - See Tractor Electrical Bill of Material For Shaft Part Number.

b - See Tools & Spares Bill of Material For Feeder Switch Paddle Part Number.

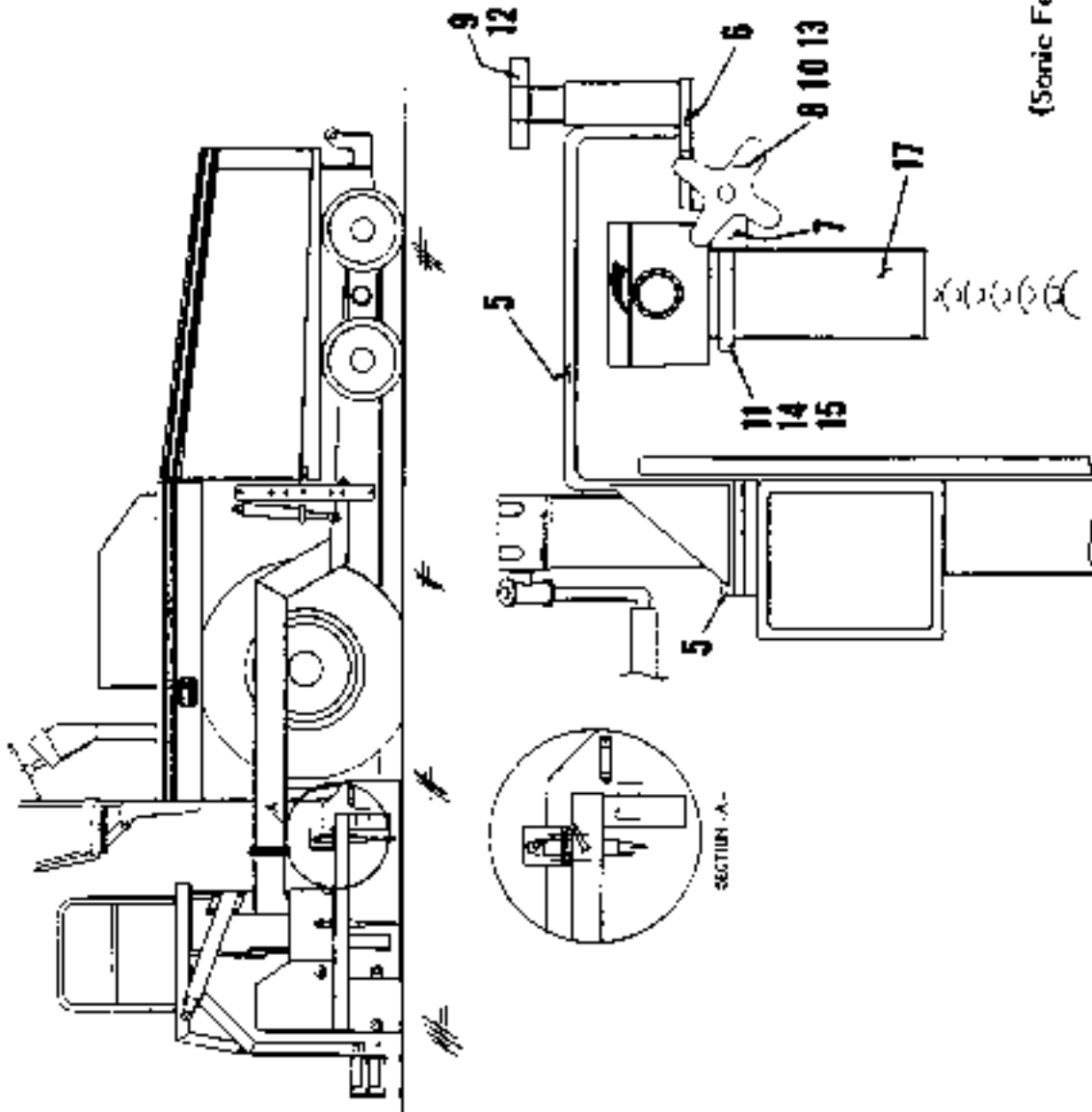

FEEDER ELECTRICAL
(Sonic Feeder Control) (For Use With Extendamat Screens)
CA-876-5285B

FEEDER ELECTRICAL
{Sonic Feeder Control} (For Use With Extendamat Screeds)

CA-876-5285B

(Before Ordering, Consult Table of Contents to Verify Proper Bill of Material Number.)

REF.	PART NUMBER	QTY.	DESCRIPTION
-------------	--------------------	-------------	--------------------

Ref. #3 thru #17 Symbolized by NONE on Illustration.

3	KA-876-5288W	1	Harness, Wiring
5	FA-876-5289W	1	Frame, Main
6	FB-876-5289W	1	Frame, Pivot
7	JC-876-5288	1	Brace
8	JG-876-5288	1	Spacer
9	29P04	1	Knob, Hand (1/2")
10	29P05	1	Knob, Hand (3/8")
11	29P06	1	U-Bolt
12	26E02	2	1/2" Star Washer
13	26E01	2	3/8" Star Washer
14	27L52	2	1/4" Cut Washer
15	26C35	2	1/4" Lock Nut
17	87N14E	1	Sensor, Sonic (Proportional) (With Connecting Coil Cord)
	A-46-2343	1	Decal "SONIC FEEDER"
	876-5286 Sht. 8	1	Print, Assembly Drawing

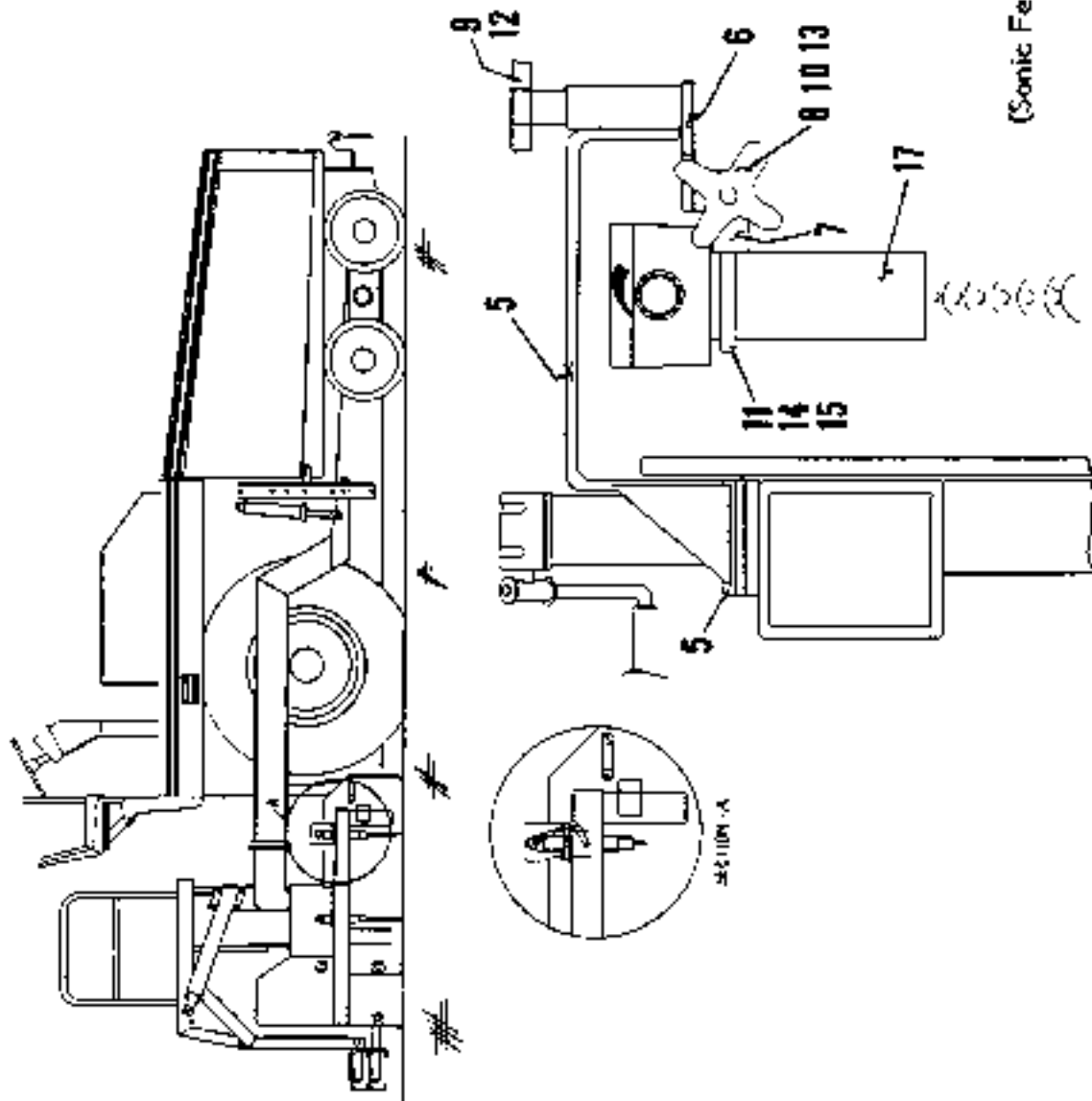

FEEDER ELECTRICAL
(Sonic Feeder Control) (For Use With Extendamat Screens)
CAI-876-5285B

FEEDER ELECTRICAL
(Sonic Feeder Control) (For Use With Extendamat Screeds)

CAI-876-5285B

(Before Ordering, Consult Table of Contents to Verify Proper Bill of Material Number.)

REF.	PART NUMBER	QTY.	DESCRIPTION
Ref. #3 thru #17 Symbolized by NONE on Illustration.			
3	KB-876-5288W	1	Harness, Wiring
5	FA-876-5289W	1	Frame, Main
6	FB-876-5289W	1	Frame, Pivot
7	JC-876-5288	1	Brace
8	JG-876-5288	1	Spacer
9	29P04	1	Knob, Hand (1/2")
10	29P05	1	Knob, Hand (3/8")
11	29P06	1	U-Bolt
12	26E02	2	1/2" Star Washer
13	26E01	2	3/8" Star Washer
14	27L32	2	1/4" Cut Washer
15	26C35	2	1/4" Lock Nut
17	87N14E	1	Sensor, Sonic (Proportional) (With Connecting Coil Cord)
	A-16-2343	1	Decal "SONIC FEEDER"
	876-5286 Sht. 10	1	Print, Assembly Drawing

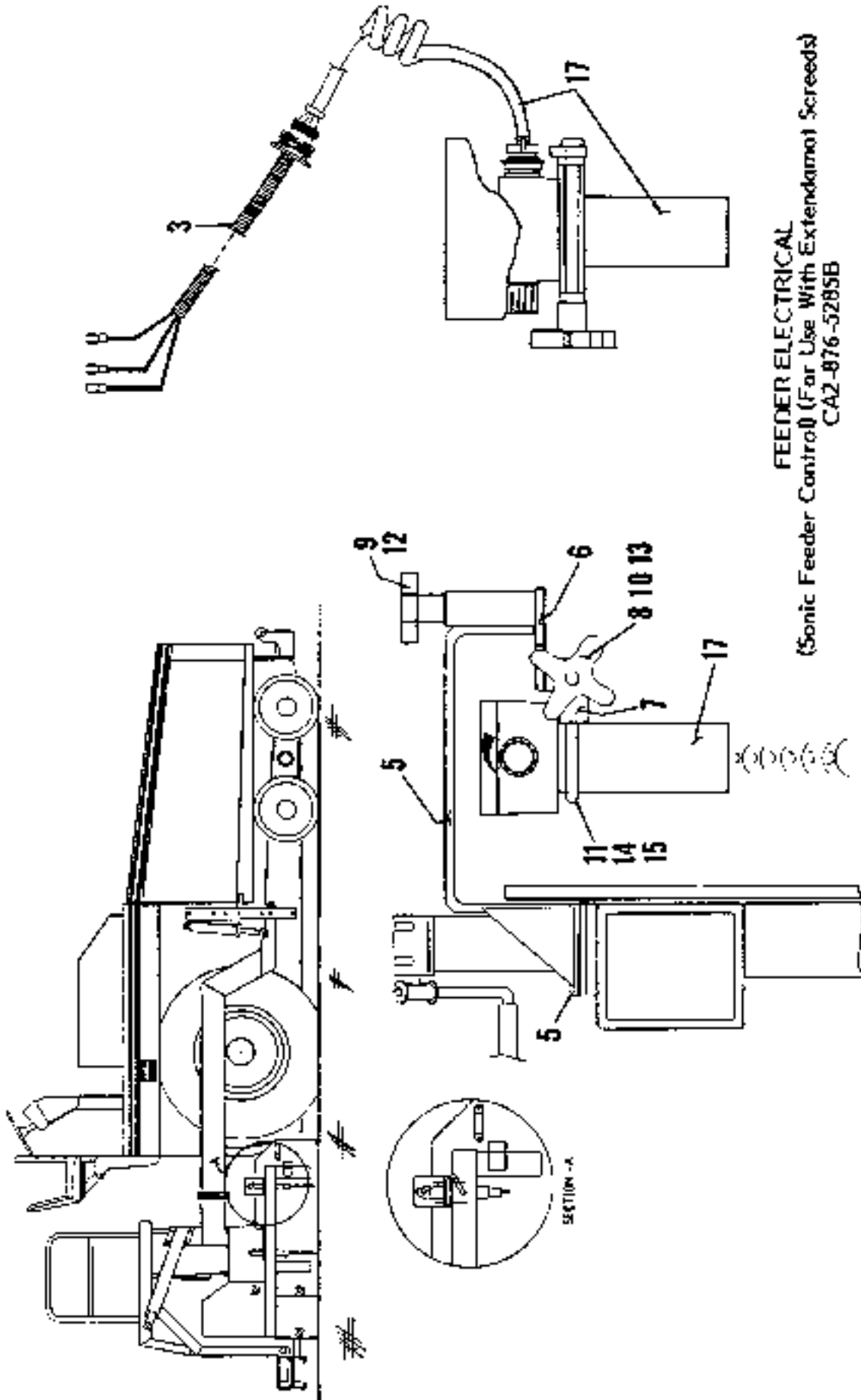

FEEDER ELECTRICAL
(Sonic Feeder Control) (For Use With Extendamat Screens)
CA2-076-5285B

FEEDER ELECTRICAL
(Sonic Feeder Control) (For Use With Extendamat Screeds)

CA2-876-5285B

(Before Ordering, Consult Table of Contents to Verify Proper Bill of Material Number.)

REF.	PART NUMBER	QTY.	DESCRIPTION
-------------	--------------------	-------------	--------------------

Ref. #3 thru #17 Symbolized by NONE on Illustration.

3	KB-876-5288W	1	Harness, Wiring
5	FA-876-5289W	1	Frame, Main
6	FB-876-5289W	1	Frame, Pivot
7	JCI-876-5288	1	Brace
8	JG-876-5288	1	Spacer
9	29P04	1	Knob, Hand (1/2")
10	29P05	1	Knob, Hand (3/8")
11	32B28	1	U-Bolt
12	26E02	2	1/2" Star Washer
13	26E01	2	3/8" Star Washer
14	27L52	2	1/4" Cut Washer
15	26C35	2	1/4" Lock Nut
17	32B29	1	Sensor, Sonic (Proportional) (With Connecting Coil Cord)
	A-46-2343	1	Decal "SONIC FEEDER"
	876-5286 Sht. 10	1	Print, Assembly Drawing

FEEDER ELECTRICAL
(Sonic Feeder Control) (For Use With Standard Vibratory Screens)
CB-876-5285B

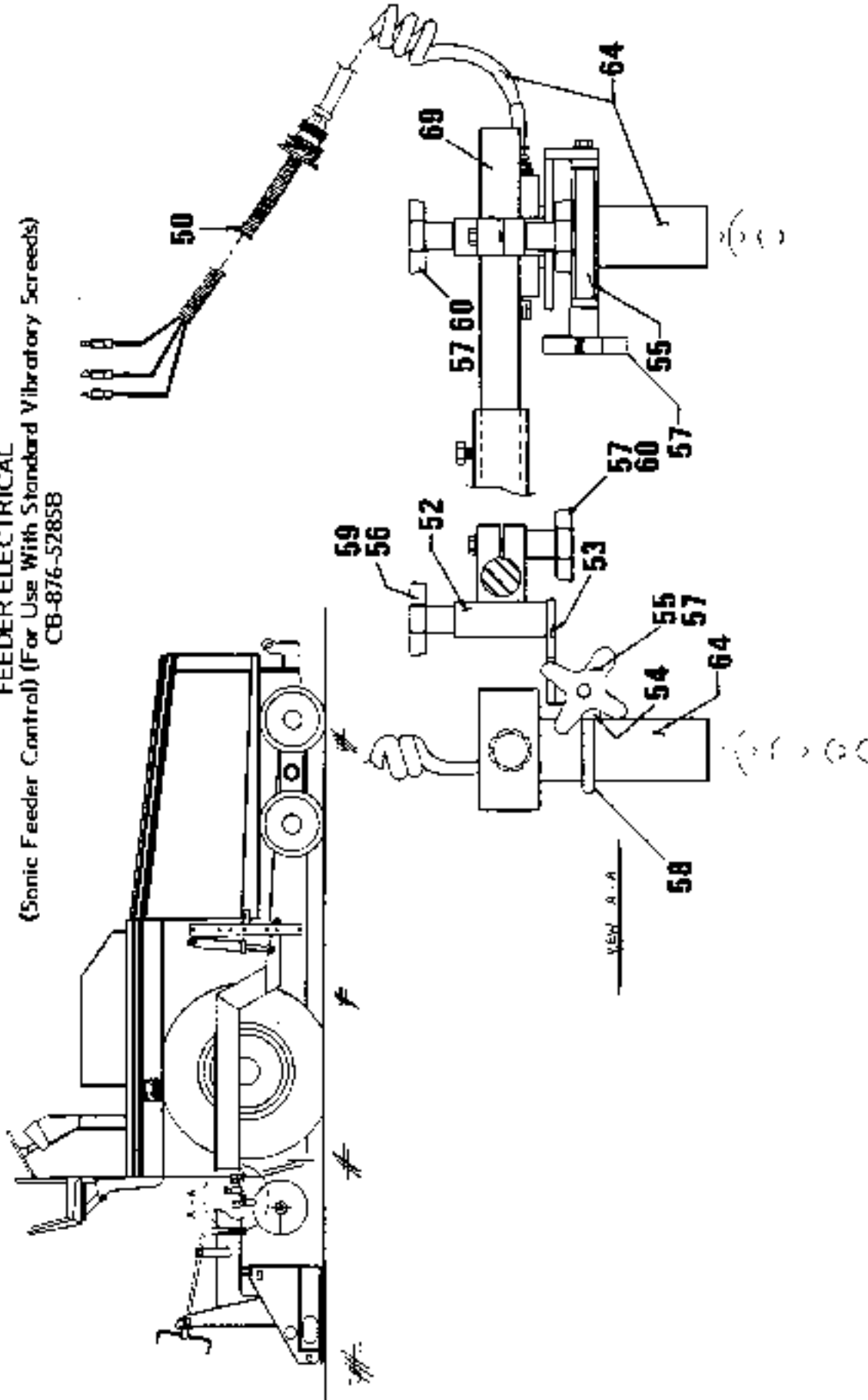

FEEDER ELECTRICAL
(Sonic Feeder Control) (For Use With Standard Vibratory Screens)

CB-876-5285B

(Before Ordering, Consult Table of Contents to Verify Proper Bill of Material Number.)

REF.	PART NUMBER	QTY.	DESCRIPTION
Ref. #50 thru #69 Symbolized by NONE on Illustration.			
50	KA-876-5288W	1	Harness, Wiring
52	FC-876-5289W	1	Frame, Bar
53	FB-876-5289W	1	Frame, Pivot
54	JC-876-5288	1	Brace
55	JG-876-5288	1	Spacer
56	29P04	1	Knob, Hand (1/2")
57	29P05	2	Knob, Hand (3/8")
58	29P06	1	U-Bolt
59	26E02	2	1/2" Star Washer
60	26E01	2	3/8" Star Washer
	27L52	2	1/4" Cut Washer
	26C35	2	1/4" Lock Nut
64	B7N14E	1	Sensor, Sonic (Proportional) (With Connecting Coil Cord)
	A-46-2343	1	Decal "SONIC FEEDER"
69	EE-876-5288	1	Shaft
	876-5286 Sht. 9	1	Print, Assembly Drawing

FEEDER ELECTRICAL
(Sonic Feeder Control) (For Use With Standard Vibratory Screens)
CB1-876-5285B

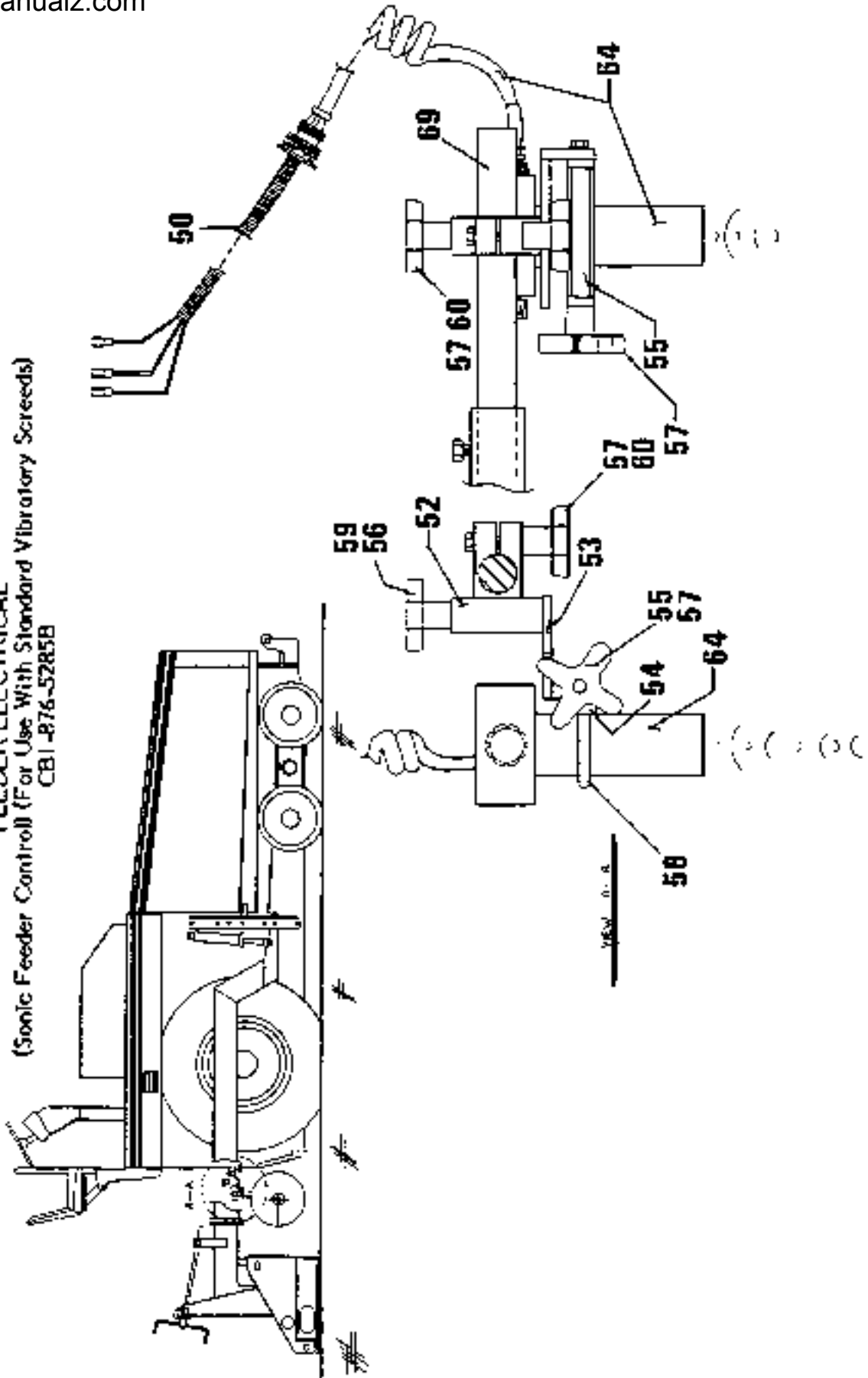

FEEDER ELECTRICAL
(Sonic Feeder Control) (For Use With Standard Vibratory Screens)

CBI-876-5285B

(Before Ordering, Consult Table of Contents to Verify Proper Bill of Material Number.)

REF.	PART NUMBER	QTY.	DESCRIPTION
------	-------------	------	-------------

Ref. #50 thru #69 Symbolized by NONE on Illustration.

50	KB-876-5288W	1	Harness, Wiring
52	FC-876-5289W	1	Frame, Bar
53	FB-876-5289W	1	Frame, Pivot
54	JC-876-5288	1	Brace
55	JG-876-5288	1	Spacer
56	29P04	1	Knob, Hand (1/2")
57	29P05	2	Knob, Hand (3/8")
58	29P06	1	U-Bolt
59	26E02	2	1/2" Star Washer
60	26E01	2	3/8" Star Washer
	27L52	2	1/4" Cot Washer
	26C35	2	1/4" Lock Nut
64	87NI4E	1	Sensor, Sonic (Proportional) (With Connecting Coil Cord)
	A-46-2343	1	Decal "SONIC FEEDER"
69	EE-876-5288	1	Shaft
	876-5286 Sht. 11	1	Print, Assembly Drawing

FEEDER ELECTRICAL
(Sonic Feeder Control) (For Use With Standard Vibratory Screens)
CB2-876-5285B

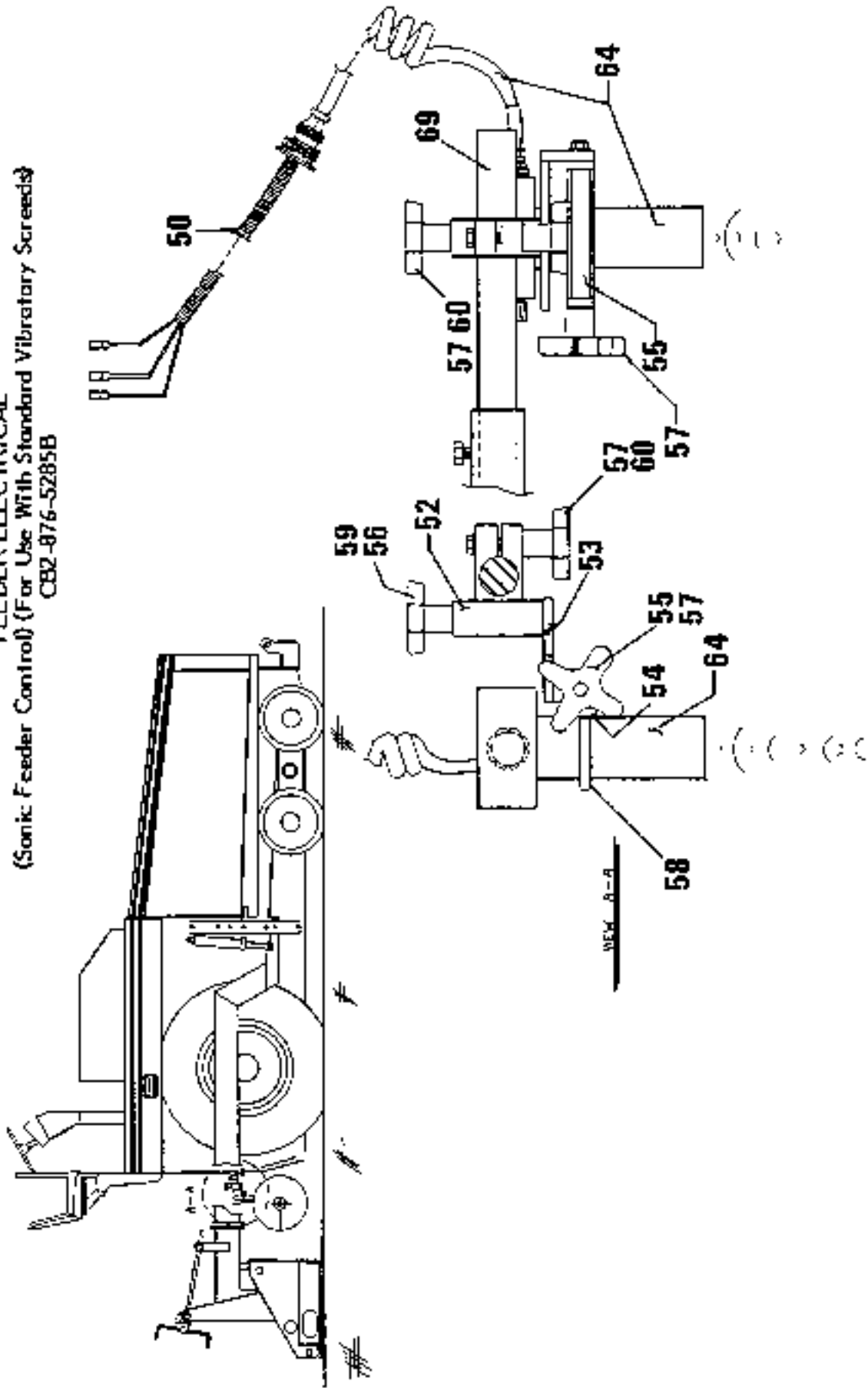

FEEDER ELECTRICAL
(Sonic Feeder Control) (For Use With Standard Vibratory Screens)

CBZ-876-5285B

(Before Ordering, Consult Table of Contents to Verify Proper Bill of Material Number.)

REF.	PART NUMBER	QTY.	DESCRIPTION
Ref. #50 thru #69 Symbolized by NONE on Illustration.			
50	KB-876-5288W	1	Harness, Wiring
52	FC-876-5289W	1	Frame, Bar
53	FB-876-5289W	1	Frame, Pivot
54	JCI-876-5288	1	Brace
55	JG-876-5288	1	Spacer
56	29P04	1	Knob, Hand (1/2")
57	29P05	2	Knob, Hand (3/8")
58	32B28	1	U-Bolt
59	26E02	2	1/2" Star Washer
60	26E01	2	3/8" Star Washer
	27L52	2	1/4" Cut Washer
	26C35	2	1/4" Lock Nut
64	32B29	1	Sensor, Sonic (Proportional) (With Connecting Coil Cord)
	A-46-2343	1	Decal "SONIC FEEDER"
69	EE-876-5288	1	Shaft
	876-5286 Sht. 11	1	Print, Assembly Drawing

BACK-UP ALARM ELECTRICAL
E-876-5485B

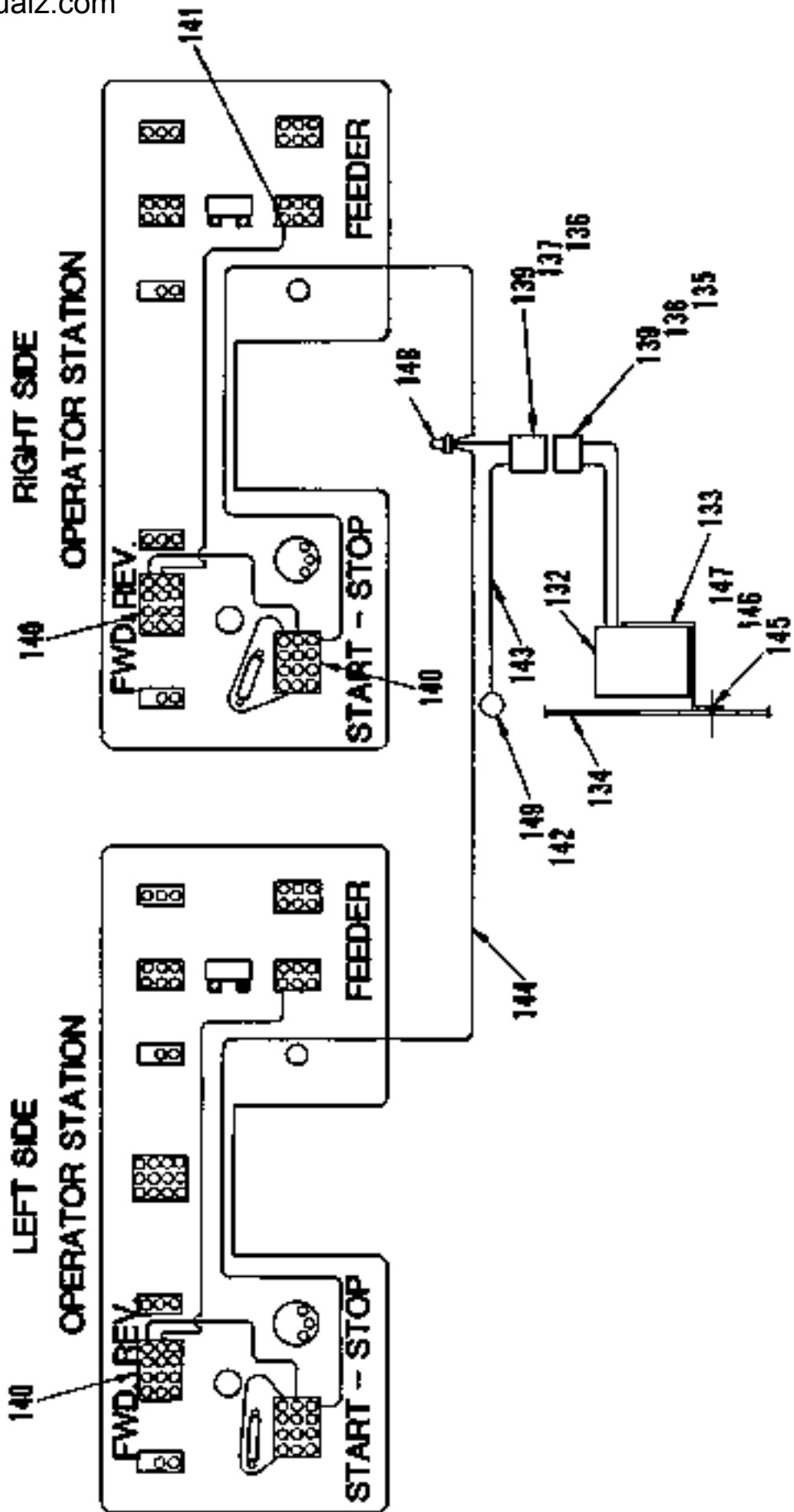

BACK-UP ALARM ELECTRICAL

E-876-5485B

(Before Ordering, Consult Table of Contents to Verify Proper Bill of Material Number.)

REF.	PART NUMBER	QTY.	DESCRIPTION
Ref. #132 thru #149 Symbolized by NONE on Illustration.			
132	23W82	1	Alarm, Back-Up
133	FC-876-5288	1	Support, Alarm
134	FD-876-5288	1	Cover, Rear
135	28F22	1	Tower
136	28F20	1	Shroud
137	28F23	2	Terminal, Male
138	28F24	2	Terminal, Female
139	28F25	4	Seal, Cable
140	20Z53	3	Switch
141	11P92	10	Terminal, #6 Ring
142	20D21	1	Terminal, 3/8" Ring
143	20K49	1	Wire, 14 Ga. White x 2'-0"
144	20A48	1	Wire, 14 Ga. Black x 20'-0"
145	13J30	2	3/8" x 3/4" Hex Head Cap Screw
146	27L78	2	3/8" Lock Washer
147	27C90	2	3/8" Nut
148	20F38	1	Connector
149	14V10	1	Tube, Shrink x 1"

BACK-UP ALARM ELECTRICAL
EI-876-5485B

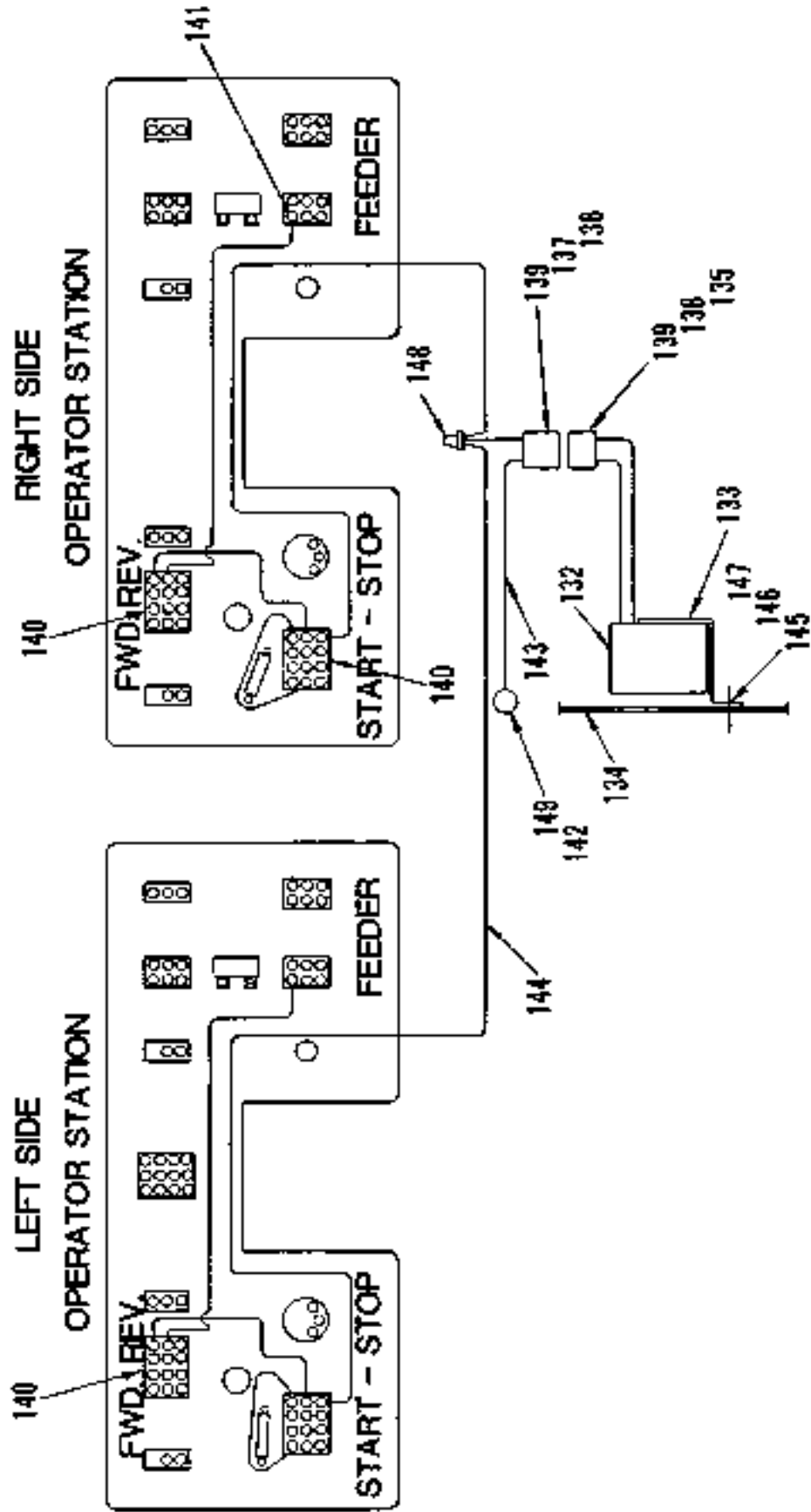

BACK-UP ALARM ELECTRICAL

EI-876-54853

(Before Ordering, Consult Table of Contents to Verify Proper Bill of Material Number.)

REF.	PART NUMBER	QTY.	DESCRIPTION
------	-------------	------	-------------

Ref. #132 thru #149 Symbolized by NONE on illustration.

132	23W82	1	Alarm, Back-Up
133	FC-876-5288	1	Support, Alarm
134	HB-876-5288	1	Cover, Rear
135	28F22	1	Tower
136	28F20	1	Shroud
137	28F23	2	Terminal, Male
138	28F24	2	Terminal, Female
139	28F25	4	Seal, Cable
140	20Z53	3	Switch
141	11P92	10	Terminal, #6 Ring
142	20D21	1	Terminal, 3/8" Ring
143	20K48	1	Wire, 14 Ga. White x 2'-0"
144	20A48	1	Wire, 14 Ga. Black x 20'-0"
145	13J30	2	3/8" x 3/4" Hex Head Cap Screw
146	27L78	2	3/8" Lock Washer
147	27C90	2	3/8" Nut
148	20F38	1	Connector
149	14V10	1	Tube, Shrink x 1"

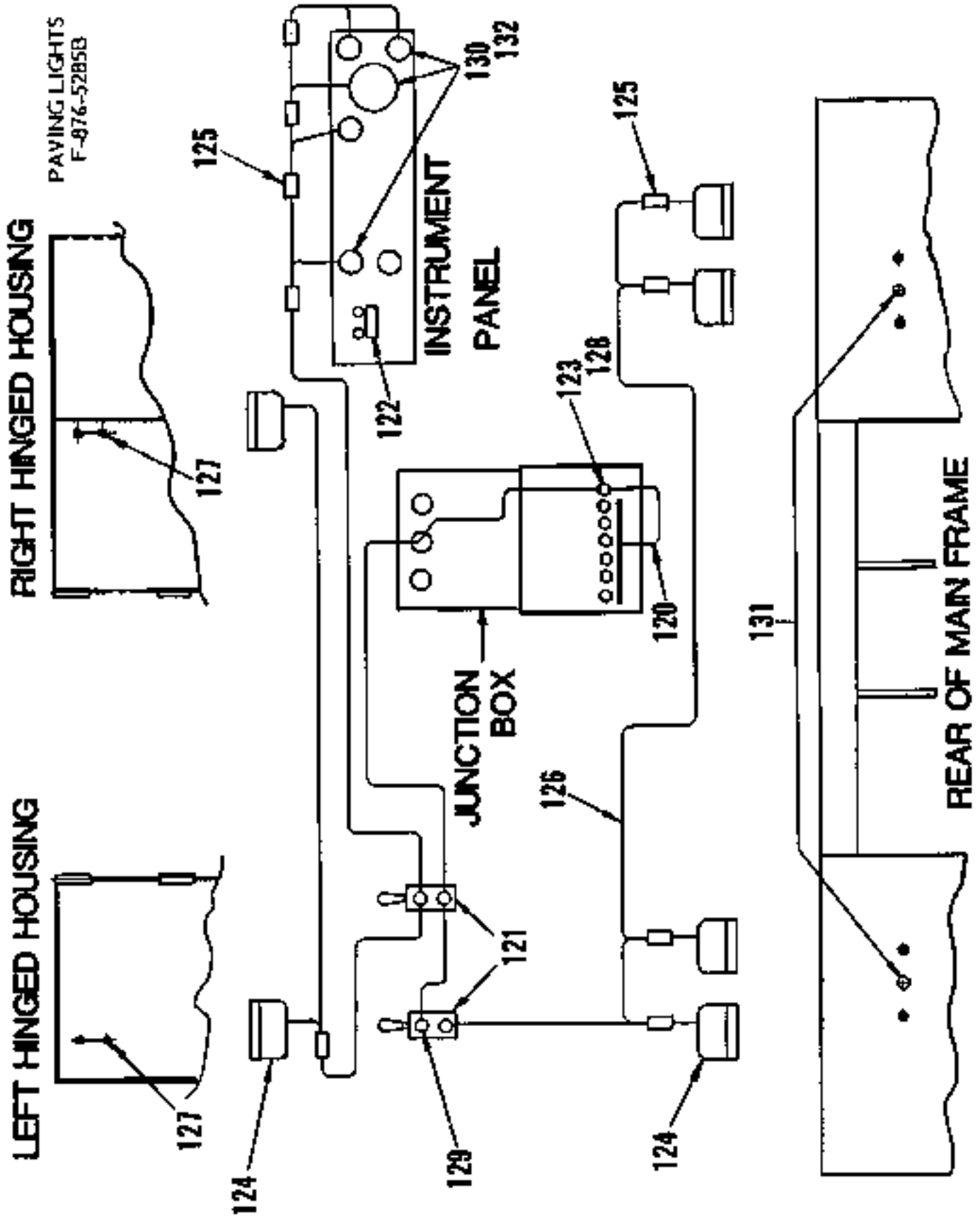

PAVING LIGHTS

F-876-5285B

(Before Ordering, Consult Table of Contents to Verify Proper Bill of Material Number.)

REF.	PART NUMBER	QTY.	DESCRIPTION
Ref. #120 thru #132 Symbolized by NONE on Illustration.			
120	GK-876-5287W	1	Wire, Jumper
121	20P60	2	Switch
122	A-46-2251	1	Name Plate
123	13A03	1	Breaker, Circuit (10 AMP)
124	26L36	6	Lamp, Flood
125	20F39	9	Connector (14-16 Ga.)
126	20A48	1	Wire, 14 Ga. Black x 40'-0"
127	38Z83	2	Grommet
128	20Z66	1	Terminal, #8 Ring (14 Ga.)
129	11P92	6	Terminal, #6 Ring (14 Ga.)
130	27T40	5	Socket, Light Kit
131	50D23	2	Grommet
132	28N19	5	Bulb, Light

RIGHT HINGED HOUSING

LEFT HINGED HOUSING

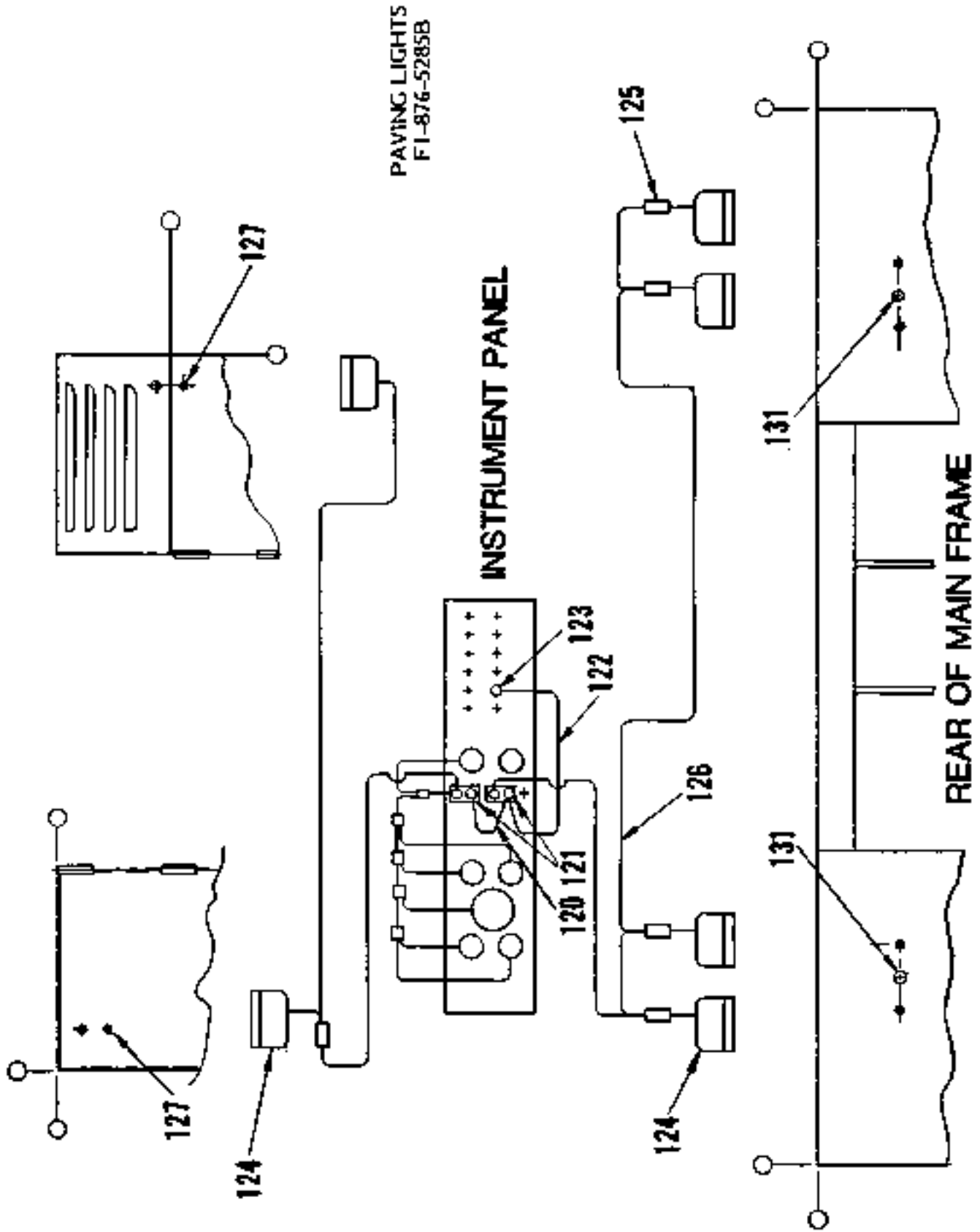

PAVING LIGHTS
FI-876-5285B

PAVING LIGHTS

FI-876-5285B

(Before Ordering, Consult Table of Contents to Verify Proper Bill of Material Number.)

REF.	PART NUMBER	QTY.	DESCRIPTION
Ref. #120 thru #131 Symbolized by NONE on Illustration.			
120	GJ-876-5287W	1	Wire, Jumper
121	20P60	2	Switch
122	GY-876-5287W	1	Wire, Jumper
123	13A05	1	Breaker, Circuit (30 AMP)
124	26L36	6	Lamp, Flood
125	20F39	10	Connector (14-16 Ga.)
126	20A48	1	Wire, 14 Ga. Black x 40'-0"
127	3BZB3	2	Grummet
	11P92	4	Terminal, #6 Ring (14 Ga.)
	27T40	6	Socket, Light Kit
131	50D23	2	Grummet
	28N19	6	Bulb, Light

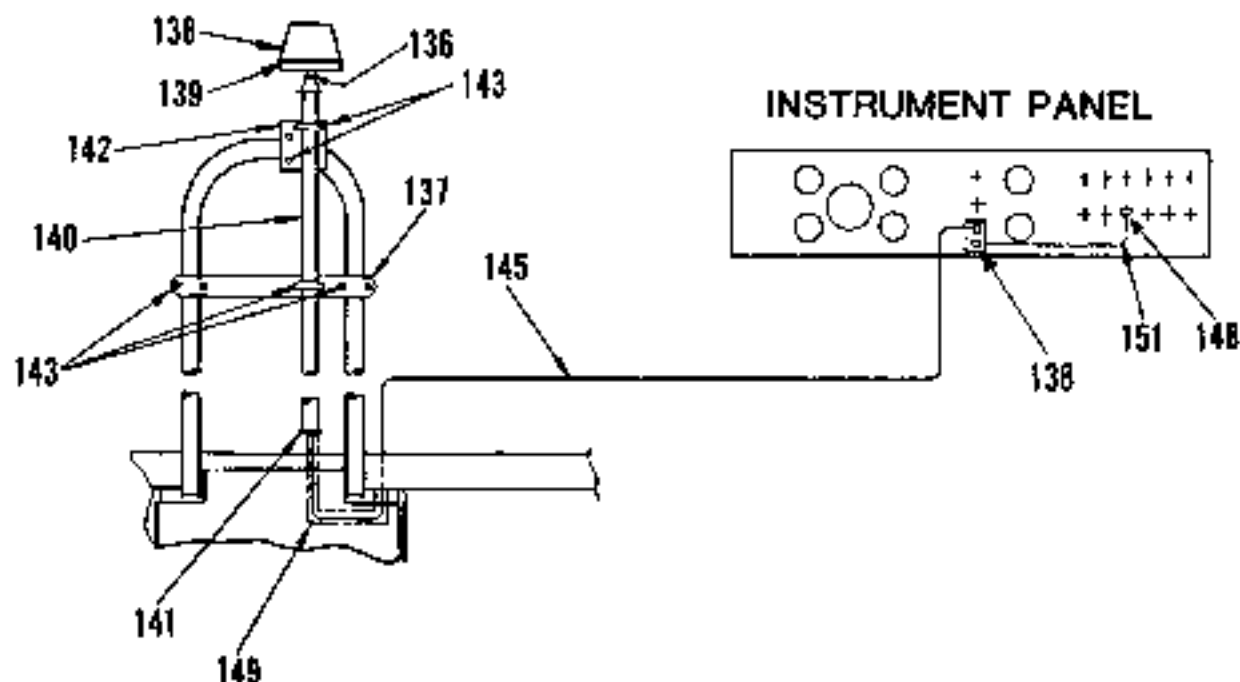

WARNING LIGHTS

G-876-5285B

(Before Ordering, Consult Table of Contents to Verify Proper Bill of Material Number.)

REF.	PART NUMBER	QTY.	DESCRIPTION
136	23B13	1	Connector, 3/4" N.P.T.F. x 1" N.P.T.F.
137	DD-876-5288	1	Bar, Support
138	26J65	1	Light & Switch Assembly, 12 Volt (Amber)
139	26J71	1	Kit, Post Mounting
140	EU-17-124	1	Pipe, 1" Diameter x 42"
141	20GB9	1	Bushing, 1" Conduit
142	A-876-4848	1	Plate, Mounting
143	16R42	5	U-Bolt
	20F39	1	Connector (14-16 Ga.)
145	20A48	1	Wire, 14 Ga. Black x 18'-0"
146	11P92	1	Terminal, #6 Ring (14 Ga.)
148	13A03	1	Breaker, Circuit (10 AMP)
149	13M13	1	Loom, 1/4" I.D. x 2'-0"
	a	b	Tape, Electrical
151	CY-876-5287W	1	Wire, Jumper

a - Purchase Locally.

b - Use as Required.

8/20/91 (2-14)

SECTION 10

BG-220B Asphalt Paver

HYDRAULIC COMPONENTS

TRACTOR HYDRAULICS
(Hydraulic Tank Assembly)
(Illustration 1 of 2)

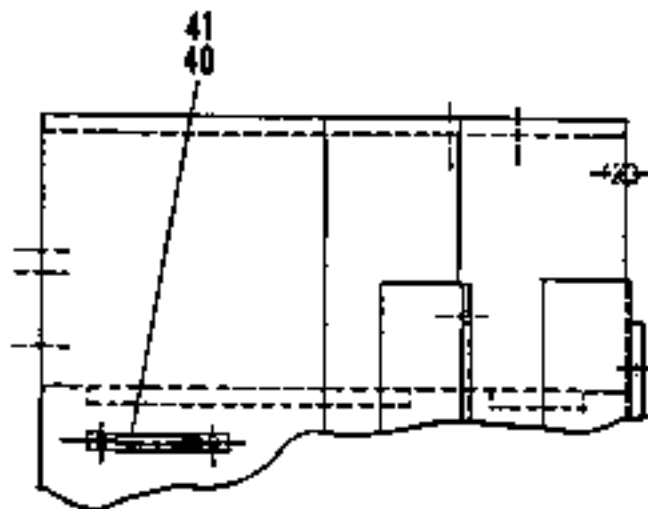
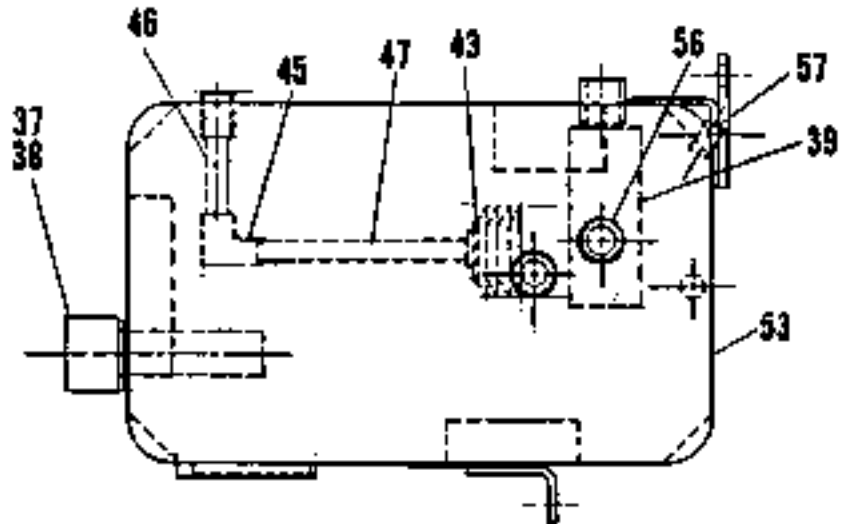
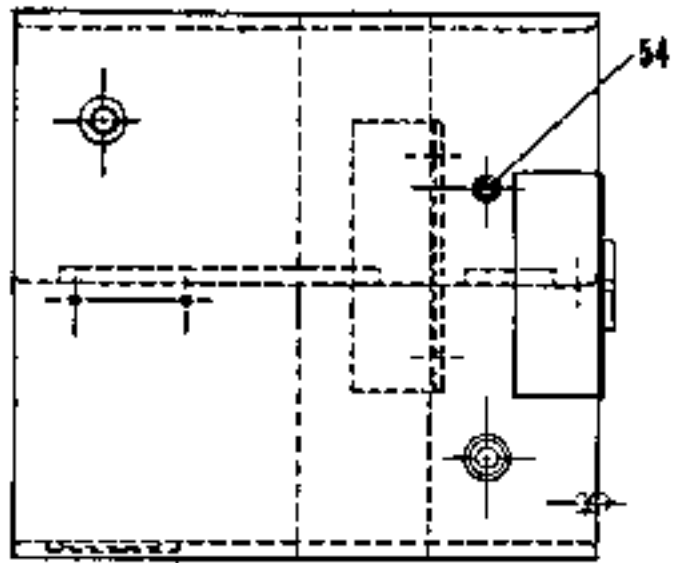
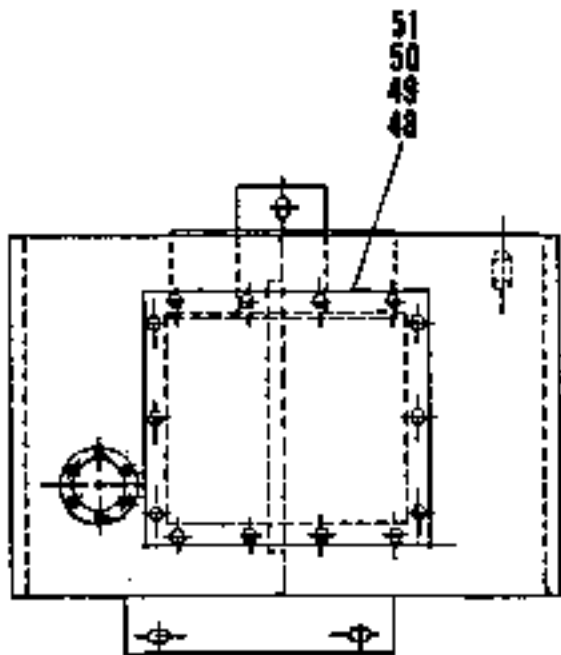

Key to
Reference Number Symbols

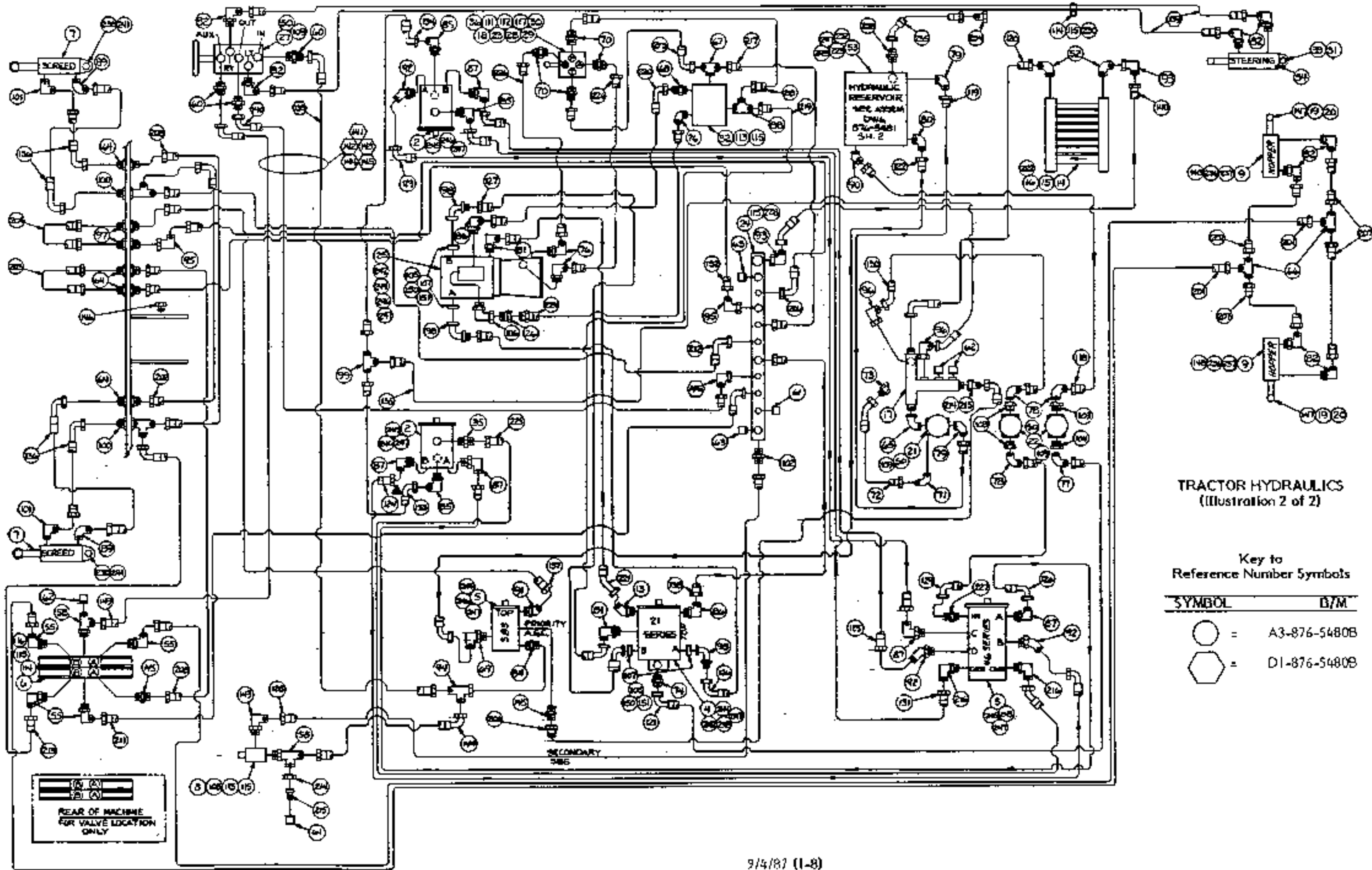

SYMBOL	B/M
---------------	------------

NONE = A3-B76-5480B
(Tractor Hydraulics)



TRACTOR HYDRAULICS
(Illustration 2 of 2)

Key to
Reference Number Symbols

SYMBOL	D/M
	A3-876-5480B
	D1-876-5480B

TRACTOR HYDRAULICS

A3-876-5480B

(Before Ordering, Consult Table of Contents to Verify Proper Bill of Material Number.)

REF.	PART NUMBER	QTY.	DESCRIPTION
Ref. #2 thru #247 Symbolized by NONE on Illustration 1 and			
Also Symbolized by  on Illustration 2.			
2	28N95	2	Motor, Hydraulic (Feeder & Screw) (See Section 12 For Breakdown)
3	28L38	1	Pump, Hydraulic (Feeder & Screw Tandem) (See Section 12 For Breakdown)
4	28G25	1	Pump, Hydraulic (Propel) (With Hydro Transmission Valve) (See Section 12 For Breakdown)
5	27X33	1	Pump, Hydraulic (SBS) (Screed Lift, Hopper Cylinders & Steering) (See Section 12 For Breakdown)
6	15K55	1	Valve (Screed Lift, Hopper Cylinders & Steering) (See Section 12 For Breakdown)
7	28L43	2	Cylinder, Hydraulic (Screed Lift) (See Section 12 For Breakdown)
8	28N77	1	Valve, Relief
9	27V85	2	Cylinder, Hydraulic (Hopper) (See Section 12 For Breakdown)
	10A06	1	Trim, Plastic x 2'-0" (Quickedge)
13	12Z35	1	Elbow, 45° - 3/4" T. x 7/8"-14 Str. Thd.
14	26S53	1	Cooler, Oil
15	14D76	1	Kit, Cooler Mounting
16	BD-876-5283	2	Strap, Spacer
17	A1-80-556W	1	Manifold, Hydraulic
18	13J54	2	1/4" Lock Nut
19	A-876-5282W	2	Pin, Hopper Cylinder
20	26B08	2	3/8" x 3/4" Socket Head Set Screw
21	16W35	1	Filter (Return) (Consisting in part of the following indented item):
	16X52	1	. Element, Filter
22	16W34	2	Filter (Charge) (Consisting in part of the following indented item):
	16X52	1	. Element, Filter
23	27L99	4	#10 Lock Washer
24	A1-80-567W	1	Manifold (Return)
25 a	27Y30	1	Motor, Hydraulic (Propel)
26	27Y33	1	Fitting, Orifice
27	27Y29	1	Steering Unit
28	28J08	4	#10-24 x 2" Socket Head Cap Screw
29	27Y31	1	Valve, Shift
30	27Y32	1	Subplate
31	A-46-2207	1	1"-8 x 2-1/2" Ferry Head Cap Screw (Drilled Head)
32	27X16	1	Valve, Solenoid (See Section 12 For Breakdown)
33	F-17-478	1	1-1/32" I.D. x 2" O.D. x 1/4" Thick Washer

REF.	PART NUMBER	QTY.	DESCRIPTION
34	28M35	1	Cylinder, Hydraulic (Steering) (See Section 12 For Breakdown)
35	23R69	1	Connector, 3/4" T. x 3/4"-16 Str. Thd.
36	B-876-5483	1	Plate, Valve Mounting
	26B80	6	#10-24 x 1/2" Self Tapping Screw
38	28F47	1	Breather (Filler)
39	31L98	1	Strainer, Suction
40	10P30	1	Gauge, Level
41	27D20	2	1/2"-20 Nut
43	16W28	1	Diffuser
45	G-80-85	1	Elbow, 1-1/4"
46	DT-80-80	1	Nipple, 1-1/4" x 3-1/2"
47	K-17-125	1	Nipple, 1-1/4" x 9"
48	AC-876-5483	1	Cover, Access
49	F-876-3108	1	Gasket
50	26E25	26	5/16" x 3/4" Hex Head Cup Screw
51	26E54	14	5/16" Washer (Sealing)
52	14C38	2	Elbow, 90° - 1-1/4" T. x 1-1/4" Male N.P.T.F.
53	A1-876-5482W	1	Tank, Hydraulic
54	20M52	1	Sensor, Temperature
55	14L07	4	Elbow, 90° - 3/8" T. x 3/4"-16 Thd., O-Ring
56	23A81	1	Plug, 1" N.P.T. Pipe
57	12L57	1	Plug, 1/8" N.P.T. Pipe
58	23R60	2	Tee, 1/2" T. x 1/2" T. x 3/4"-16 Thd. O-Ring
	10C56	1	Oil, Hydraulic (45.2 Gallons)
60	23W72	3	Connector, 1/2" Tube x 9/16"-18 Thd.
61	12T24	2	Cap, 3/8" Tube
62	12T60	3	Cap, 1/2" Tube
63	23G64	2	Cap, 3/4" Tube
64	12X17	4	Bulkhead, 3/8" Tube x 3/8" Tube
65	16L59	1	Elbow, 1-1/4" St.
66	12X40	2	Tee, 3/8" Sq. Tube x 3/8" Tube
67	11K44	1	Tee, 3/8" Sq. Tee x 1/4" N.P.T.F.
68	23A06	1	Connector, 3/8" Tube x 1/4" N.P.T.F.
69	13D39	1	Elbow, 90°, 1-1/4" Tube x 1-5/8"-17 Str.
70	23P62	4	Connector, 3/8" Tube x 3/8" N.P.T.F.
71	23L84	1	Elbow, 90° - 1/4" T. x 1/8" N.P.T.F.
72	D-80-565W	1	Hose, 1/4" I.D. x 35"
73	27Y59	1	Connector, 1/4" T. x 1/8" N.P.T.F.
74	23K83	1	Connector, 3/4" Tube x 7/8"-14 Thd., O-Ring
76	23C20	3	Elbow, 90°, 3/8" Tube x 1/4" N.P.T.F.
77	23F29	1	Elbow, 90°, 3/4" Tube x 3/4" N.P.T.F.
78	23K04	3	Elbow, 90°, 1" Tube x 1" N.P.T.F.
79	14C38	2	Elbow, 90° - 1-1/4" T. x 1-1/4" N.P.T.F.
80	28G03	1	Elbow, 90°, 1-1/4" Tube x 3-1/2" N.P.T.F.
81	23N82	2	Elbow, 90°, 1/4" Tube x 7/16"-20 Thd., O-Ring
82	23P61	8	Elbow, 90°, 3/8" Tube x 9/16"-18 Thd., O-Ring
84	23J51	1	Connector, 1/2" Tube x 7/8"-14 Thd., O-Ring
85	28G04	3	Elbow, 90°, 3/4" Tube x 3/4"-16 Thd., O-Ring
86	13G10	2	Elbow, 90°, 3/4" Tube x 7/8"-14 Thd., O-Ring

9/4/87 (1-10) (2-8)

SECTION 10 PAGE 4

(Continued)

REF.	PART NUMBER	QTY.	DESCRIPTION
87	23J55	5	Elbow, 90°, 1" Tube x 1-15/16"-12 Thd.,- O-Ring
88	15B96	1	Tee, 3/8" Sq. Tube x 1/4" N.P.T.F.
89	23R41	2	Elbow, 90°, 3/8" Tube x 1/2" N.P.T.F.
90	13M64	1	Elbow, 45°, 1" Tube x 1" N.P.T.F.
91	15J70	1	Elbow, 45°, 3/4" Tube x 1-1/16"-12 Thd.,- O-Ring
92	23J56	3	Elbow, 45°, 1" Tube x 1-5/16"-12 Thd.,- O-Ring
93	14T33	2	Elbow, 90°, 1-1/4" Tube x 1-1/4" J.I.C. Swivel
94	13J69	1	Tee, 1/2" Sq. Tube x 1/2" J.I.C. Swivel
95	26J04	2	Elbow, 90°, 3/4" Tube x 3/4" J.I.C. Swivel
96	14T34	2	Elbow, 90°, 1" Tube x 1" J.I.C. Swivel
97	12X09	2	Bulkhead, 3/4" Tube x 3/4" Tube
98	27R41	3	Elbow, 90°, 1" Tube x 1" Flange
99	14Y57	1	Tee, 1" Tube x 1" Tube x 1" Tube
100	12W74	2	Tee, Bulkhead, 3/8" Tube x 3/8" Tube 3/8" Tube
101	13K98	2	Elbow, 90°, 3/8" Tube x 1/2" Male N.P.T.F. x 1/16" Orifice
102	23H54	1	Connector, 1/2" T. x 3/4"-16 Str. Thd.
103	10D99	3	Bushing, Reducing, 1" x 1-1/4"
104	23R36	1	Bushing, Reducing, 3/4" x 1-1/4"
105	50J11	4	O-Ring
106	28C06	1	Elbow, 90°, 1/4" Swivel x 7/16"-20 Str. O-Ring
107	10E09	8	Flange, 1" Split
108	27C86	2	1/4" Hex Nut
109	27L77	12	5/16" Lock Washer
111	26C53	2	3/8" x 1" Hex Head Cap Screw
112	27L78	4	3/8" Lock Washer
113	16W90	4	1/4" x 2" Hex Head Cap Screw
114	13J31	5	1/4" x 3/4" Hex Head Cap Screw
115	27L76	13	1/4" Lock Washer
116	27L52	4	1/4" Cut Washer
117	27C90	2	3/8" Hex Nut
118	AD-80-509W	1	Hose, 1" I.D. x 35"
119	AB-80-513W	1	Hose, 1-1/4" I.D. x 35"
120	D-80-571W	1	Hose, 1-1/4" I.D. x 63"
121	D-80-516W	1	Hose, 3/4" I.D. x 33"
122	D-80-571W	1	Hose, 1-1/4" I.D. x 33"
123	D-80-570W	1	Hose, 1" I.D. x 96"
124	M-80-570W	1	Hose, 1" I.D. x 68"
125	BG-80-485W	1	Hose, 1" I.D. x 89"
126	AZ-80-485W	2	Hose, 1" I.D. x 63"
127	AG-80-485W	1	Hose, 1" I.D. x 60"
128	DL-80-482W	1	Hose, 3/8" I.D. x 43"
129	Y-80-510W	1	Hose, 1" I.D. x 37"
130	G-80-512W	1	Hose, 1" I.D. x 25"
131	AG-80-516W	1	Hose, 3/4" I.D. x 98"
132	AZ-80-479W	1	Hose, 3/4" I.D. x 76"
133	Y-80-516W	1	Hose, 3/4" I.D. x 20"
134	AJ-80-516W	1	Hose, 3/4" I.D. x 30"
135	H-80-512W	1	Hose, 1" I.D. x 41"
136	R-80-491W	4	Hose, 3/8" I.D. x 34"

REF.	PART NUMBER	QTY.	DESCRIPTION
137	AV-80-480W	1	Hose, 3/4" I.D. x 91"
138	N-80-479W	1	Hose, 3/4" I.D. x 34"
140	A-80-592W	1	Hose, 1-1/4" I.D. x 66"
143	23P99	1	Elbow, 90° - 1/2" T. x 3/4"-16 Str. Thd.
144	BZ-80-491W	1	Hose, 3/8" I.D. x 41"
145	23R04	1	Connector, 3/8" T. x 3/4"-16 Str. Thd.
146	15C75	1	Plug, 1-3/16"-12 Str. Thd. w/ O-Ring
147	23C66	2	Fitting, 1/8" N.P.T.F. x 90°
148	23C60	2	Fitting, 1/8" N.P.T.F., Str.
149	BT-80-491W	1	Hose, 3/8" I.D. x 104"
150	10E10	16	3/8" x 1-1/4" Hex Head Cap Screw
151	27L78	16	3/8" Lock Washer
201	X-80-482W	2	Hose, 3/8" I.D. x 80"
202	BK-80-491W	1	Hose, 3/8" I.D. x 71"
203	L-80-482W	1	Hose, 3/8" I.D. x 29"
204	L-80-479W	1	Hose, 3/4" I.D. x 30"
206	A5-80-491W	2	Hose, 3/8" I.D. x 51"
207	R-80-482W	4	Hose, 3/8" I.D. x 48"
208	BZ-80-482W	2	Hose, 3/8" I.D. x 71"
	11P81	30	Tie, Plastic Wire
	10B23	15	Tie, Plastic Wire
211	DW-80-491W	1	Hose, 3/8" I.D. x 39"
212	BY-80-491W	1	Hose, 3/8" I.D. x 66"
213	BG-80-491W	2	Hose, 3/8" I.D. x 16"
214	23F70	2	Nut, 1/2" T.
215	26J12	2	Reducer, 1/2" T. x 3/8" T.
216	23H41	2	Elbow, 90° - 3/4" T. x 1-1/16"-12 Thd., O-Ring
217	ES-80-484W	1	Hose, 1/4" I.D. x 37"
218	ET-80-484W	1	Hose, 1/4" I.D. x 17"
219	AN-80-490W	1	Hose, 1/4" I.D. x 77"
220	AP-80-490W	1	Hose, 1/4" I.D. x 48"
221	N-80-508W	1	Hose, 3/4" I.D. x 78"
222	J-876-4628	2	Spacer, 3/8" Befling
223	27L58	6	1/2" Cut Washer
224	AR-80-490W	1	Hose, 1/4" I.D. x 33"
225	L-80-508W	1	Hose, 3/4" I.D. x 68"
226	EV-80-484W	2	Hose, 1/4" I.D. x 42"
227	11V33	1	Connector, 1" T. x 1-5/8"-12 Thd., O-Ring
228	16R42	2	U-Bolt
230	20K38	1	Clamp
232	27C95	3	1/2" Hex Nut
233	23N59	1	Connector, 1" Tube x 1" N.P.T.F.
234	12T27	1	Plug, 1" Tube
235	D-80-509W	1	Hose, 1" I.D. x 37"
236	GO-17-26	2	Pin, 3/4" Dia. x 4-1/2"
237	27K98	2	1/4" x 1/2" Socket Head Set Screw
238	ZQ-17-25	2	Pin, 1" Dia. x 3-3/4"
241	27D64	4	Pin, Cotter - 3/16" x 1-1/2"
242	B-53-1794	2	Gasket
243	13J37	9	1/2" x 1-3/4" Hex Head Cap Screw

REF.	PART NUMBER	QTY.	DESCRIPTION
244	C-17-478	8	Washer, 17/32" L.D. x 1" O.D. x 1/4" Thick
245	A-53-2517	4	Gasket
246	26E29	10	1/2" x 1-1/2" Hex Head Cap Screw
247	27L81	19	1/2" Lock Washer

o - Consult Barber-Greene Repair Parts Department for repairs on this item.

TRACTOR HYDRAULICS
(Hydraulic Tank Assembly)
(Illustration 1 of 2)

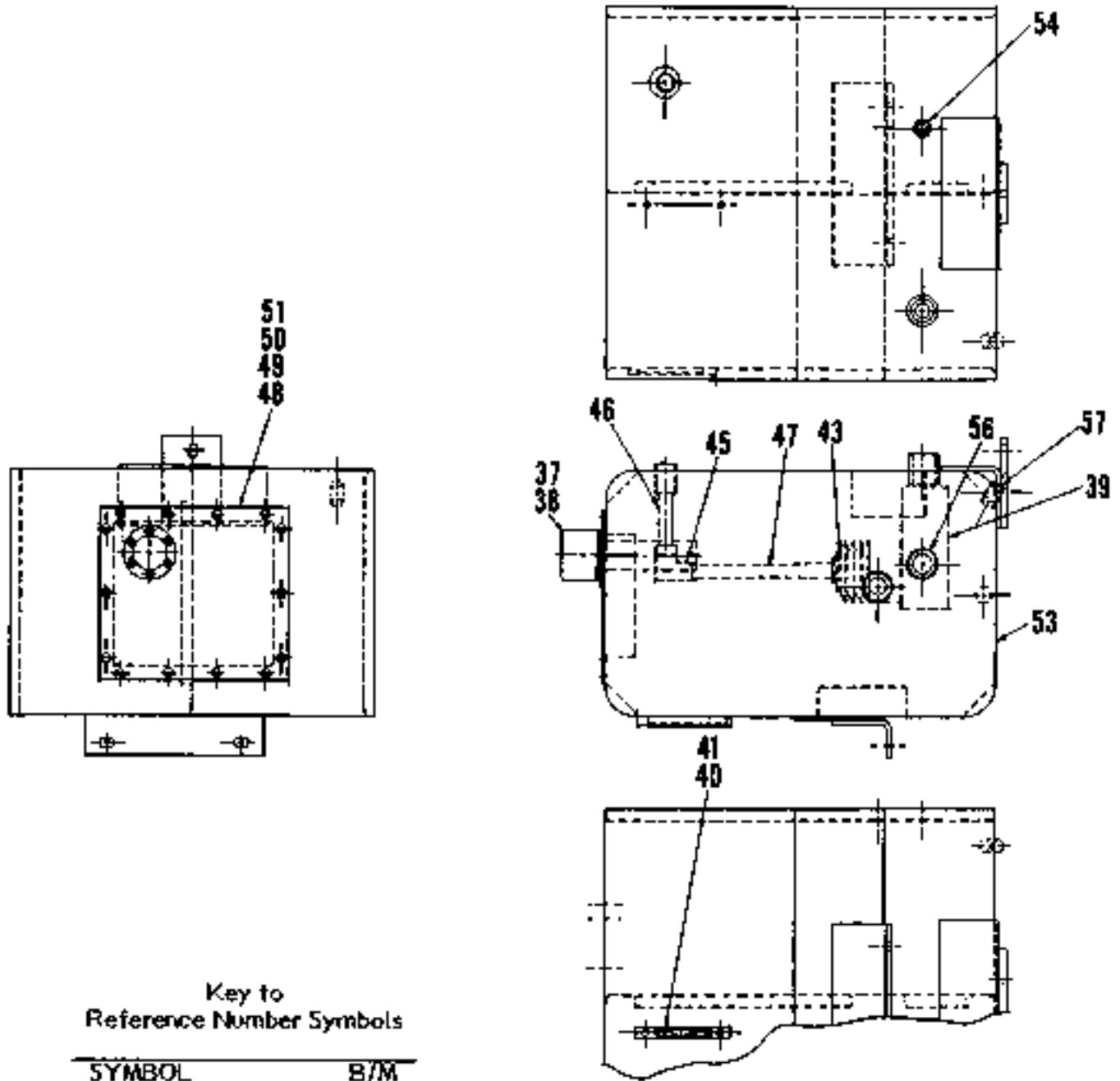

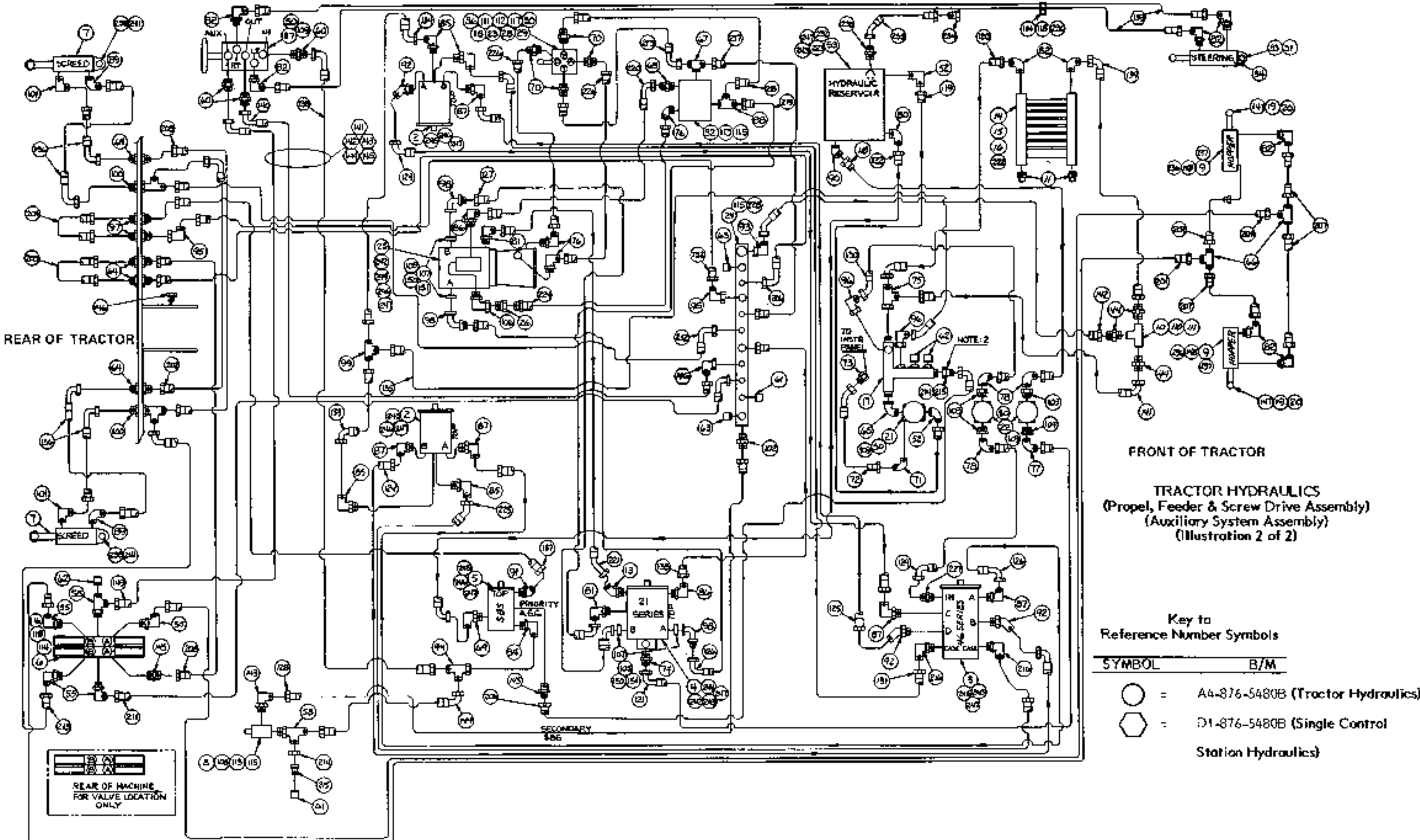

TRACTOR HYDRAULICS
 (Propel, Feeder & Screw Drive Assembly)
 (Auxiliary System Assembly)
 (Illustration 2 of 2)

Key to Reference Number Symbols

SYMBOL	B/M
○	A4-876-5480B (Tractor Hydraulics)
⬡	D1-876-5480B (Single Control Station Hydraulics)

TRACTOR HYDRAULICS

A4-876-5480B

(Before Ordering, Consult Table of Contents to Verify Proper Bill of Material Number.)

REF.	PART NUMBER	QTY.	DESCRIPTION
Ref. #2 thru #247 Symbolized by NONE on Illustration 1 and			
Also Symbolized by  on Illustration 2.			
2	28N95	2	Motor, Hydraulic (Feeder & Screw) (See Section 12 For Breakdown)
3	28L38	1	Pump, Hydraulic (Feeder & Screw Tandem) (See Section 12 For Breakdown)
4	28C25	1	Pump, Hydraulic (Propel) (With Hydro Transmission Valve) (See Section 12 For Breakdown)
5	27X33	1	Pump, Hydraulic (SBS) (Screed Lift, Hopper Cylinders & Steering) (See Section 12 For Breakdown)
6	15K55	1	Valve (Screed Lift, Hopper Cylinders & Steering) (See Section 12 For Breakdown)
7	28L43	2	Cylinder, Hydraulic (Screed Lift) (See Section 12 For Breakdown)
8	28N77	1	Valve, Relief
9	27VB5	2	Cylinder, Hydraulic (Hopper) (See Section 12 For Breakdown)
10	28W01	1	Valve, Thermal Bypass
11	23P25	2	Plug, 1-1/4" N.P.T.
	10A06	1	Trim, Plastic x 2'-0" (Quickedge)
13	12Z35	1	Elbow, 45° - 3/4" T. x 7/8"-14 Str. Thd.
14	15X46	1	Cooler, Oil
15	14D76	1	Kit, Cooler Mounting
16	BD-876-5283	2	Strap, Spacer
17	A1-80-556W	1	Manifold, Hydraulic
18	13J54	2	1/4" Lock Nut
19	A-876-52B2W	2	Pin, Hopper Cylinder
20	26B08	2	3/8" x 3/4" Socket Head Set Screw
21	16W35	1	Filter (Return) (Consisting in part of the following indented items):
	16X52	1	• Element, Filter
22	16W34	2	Filter (Charge) (Consisting in part of the following indented items):
	16X52	1	• Element, Filter
23	27L99	4	#10 Lock Washer
24	A1-80-567W	1	Manifold (Return)
25	27Y30	1	Motor, Hydraulic (Propel)
26	27Y33	1	Fitting, Orifice
27	27Y29	1	Steering Unit
28	28J08	4	#10-24 x 2" Socket Head Cap Screw
29	27Y31	1	Valve, Shift
30	27Y32	1	Subplate
31	A-46-22P7	1	1"-8 x 2-1/2" Ferry Head Cap Screw (Drilled Head)

9/4/87 (1-12) (2-9)

SECTION 10 PAGE 10

(Continued)

REF.	PART NUMBER	QTY.	DESCRIPTION
32	27X16	1	Valve, Solenoid (See Section 12 For Breakdown)
33	F-17-478	1	1-1/32" I.D. x 2" O.D. x 1/4" Thick Washer
34	28M35	1	Cylinder, Hydraulic (Steering) (See Section 12 For Breakdown)
	23R69	1	Connector, 3/4" T. x 3/4"-16 Str. Thd.
36	B-876-5483	1	Plate, Valve Mounting
37	26B80	6	#10-24 x 1/2" Self Tapping Screw
38	28F47	1	Breather (Filler)
39	31L98	1	Strainer, Suction
40	10P30	1	Gauge, Level
41	27D20	2	1/2"-20 Nut
43	16W28	1	Diffuser
44	10P73	3	Connector, 1-1/4" T. x 1-5/16-12 Str. Thd., O-Ring
45	G-80-85	1	Elbow, 1-1/4"
46	DT-80-80	1	Nipple, 1-1/4" x 3-1/2"
47	K-17-125	1	Nipple, 1-1/4" x 9"
48	AC-876-5483	1	Cover, Access
49	F-876-3108	1	Gasket
50	26E25	26	5/16" x 3/4" Hex Head Cap Screw
51	26E54	14	5/16" Washer (Sealing)
52	14C38	4	Elbow, 90° - 1-1/4" T. x 1-1/4" Male N.P.T.F.
53	A1-876-5482W	1	Tank, Hydraulic
54	20M52	1	Sensor, Temperature
55	14L07	4	Elbow, 90° - 3/8" T. x 3/4"-16 Thd., O-Ring
56	23A81	1	Plug, 1" N.P.T. Pipe
57	12L57	1	Plug, 1/8" N.P.T. Pipe
58	23R60	2	Tee, 1/2" T. x 1/2" T. x 3/4-16 Thd. O-Ring
	10C56	1	Oil, Hydraulic (45.2 Gallons)
60	23W72	3	Connector, 1/2" Tube x 9/16"-18 Thd.
61	12T24	2	Cap, 3/8" Tube
62	12T60	3	Cap, 1/2" Tube
63	23G64	2	Cap, 3/4" Tube
64	12X17	4	Bulkhead, 3/8" Tube x 3/8" Tube
65	16L59	1	Elbow, 1-1/4" St.
66	12X40	2	Tee, 3/8" Sq. Tube x 3/8" Tube
67	11K44	1	Tee, 3/8" Sq. Tee x 1/4" N.P.T.F.
68	23A06	1	Connector, 3/8" Tube x 1/4" N.P.T.F.
69	13D39	1	Elbow, 90°, 1-1/4" Tube x 1-5/8"-12 Str.
70	23P62	4	Connector, 3/8" Tube x 3/8" N.P.T.F.
71	23L84	1	Elbow, 90° - 1/4" T. x 1/8" N.P.T.F.
72	B-80-565W	1	Hose, 1/4" I.D. x 35"
73	27Y59	1	Connector, 1/4" T. x 1/8" N.P.T.F.
74	23K83	1	Connector, 3/4" Tube x 7/8"-14 Thd., O-Ring
75	14T60	1	Tee, 1-1/4" T. x 1-1/4" T. x 1-1/4" T.
76	23C20	3	Elbow, 90°, 3/8" Tube x 1/4" N.P.T.F.
77	23F29	1	Elbow, 90°, 3/4" Tube x 3/4" N.P.T.F.
78	23K04	3	Elbow, 90°, 1" Tube x 1" N.P.T.F.
80	28G03	1	Elbow, 90°, 1-1/4" Tube x 1-1/2" N.P.T.F.
81	23N82	2	Elbow, 90°, 1/4" Tube x 7/16"-20 Thd., O-Ring
82	23P61	8	Elbow, 90°, 3/8" Tube x 9/16"-18 Thd., O-Ring

REF.	PART NUMBER	QTY.	DESCRIPTION
84	23R13	1	Elbow, 90°, 1/2" Tube x 7/8"-14 Thd., O-Ring
85	28G04	3	Elbow, 90°, 3/4" Tube x 3/4"-16 Thd.,- O-Ring
86	13G10	2	Elbow, 90°, 3/4" Tube x 7/8"-14 Thd.,- O-Ring
87	23J55	5	Elbow, 90°, 1" Tube x 1-15/16"-12 Thd.,- O-Ring
88	15B96	1	Tee, 3/8" Sq. Tube x 1/4" N.P.T.F.
89	23R41	2	Elbow, 90°, 3/8" Tube x 1/2" N.P.T.F.
90	13M64	1	Elbow, 45°, 1" Tube x 1" N.P.T.F.
91	15J70	1	Elbow, 45°, 3/4" Tube x 1-1/16"-12 Thd.,- O-Ring
92	23J56	3	Elbow, 45°, 1" Tube x 1-5/16"-12 Thd.,- O-Ring
93	14T33	1	Elbow, 90°, 1-1/4" Tube x 1-1/4" J.I.C. Swivel
94	13J69	1	Tee, 1/2" Sq. Tube x 1/2" J.I.C. Swivel
95	26J04	2	Elbow, 90°, 3/4" Tube x 3/4" J.I.C. Swivel
96	14T34	2	Elbow, 90°, 1" Tube x 1" J.I.C. Swivel
97	12X09	2	Bulkhead, 3/4" Tube x 3/4" Tube
98	27R41	3	Elbow, 90°, 1" Tube x 1" Flange
99	14Y57	1	Tee, 1" Tube x 1" Tube x 1" Tube
100	12W74	2	Tee, Bulkhead, 3/8" Tube x 3/8" Tube 3/8" Tube
101	13K98	2	Elbow, 90°, 3/8" Tube x 1/2" Male N.P.T.F. x 1/16" Orifice
102	23H54	1	Connector, 1/2" T. x 3/4"-16 Str. Thd.
103	10D99	3	Bushing, Reducing, 1" x 1-1/4"
104	23R36	1	Bushing, Reducing, 3/4" x 1-1/4"
105	30J11	4	O-Ring
106	28G06	1	Elbow, 90°, 1/4" Swivel x 7/16"-20 Str. O-Ring
107	10E09	8	Flange, 1" Split
108	27C86	2	1/4" Hex Nut
109	27L77	12	5/16" Lock Washer
110	10E05	2	3/8" x 3.25" Hex Head Cap Screw
111	26C53	2	3/8" x 1" Hex Head Cap Screw
112	27L78	4	3/8" Lock Washer
113	16W90	4	1/4" x 2" Hex Head Cap Screw
114	13J31	5	1/4" x 3/4" Hex Head Cap Screw
115	27L76	13	1/4" Lock Washer
116	27L52	4	1/4" Cut Washer
117	27C90	2	3/8" Hex Nut
118	AD-80-509W	1	Hose, 1" I.D. x 35"
119	AB-80-513W	1	Hose, 1-1/4" I.D. x 35"
120	D-80-571W	1	Hose, 1-1/4" I.D. x 63"
121	D-80-516W	1	Hose, 3/4" I.D. x 33"
122	B-80-571W	1	Hose, 1-1/4" I.D. x 33"
123	D-80-570W	1	Hose, 1" I.D. x 96"
124	M-80-570W	1	Hose, 1" I.D. x 68"
125	BG-80-485W	1	Hose, 1" I.D. x 89"
126	AZ-80-485W	2	Hose, 1" I.D. x 63"
127	AG-80-485W	1	Hose, 1" I.D. x 60"
128	DL-80-492W	1	Hose, 3/8" I.D. x 43"
129	Y-80-510W	1	Hose, 1" I.D. x 37"
130	G-80-512W	1	Hose, 1" I.D. x 25"
131	AG-80-516W	1	Hose, 3/4" I.D. x 98"
132	AZ-80-479W	1	Hose, 3/4" I.D. x 76"

REF.	PART NUMBER	QTY.	DESCRIPTION
133	Y-80-516W	1	Hose, 3/4" I.D. x 20"
134	AJ-80-516W	1	Hose, 3/4" I.D. x 30"
135	H-80-512W	1	Hose, 1" I.D. x 41"
136	R-80-491W	4	Hose, 3/8" I.D. x 34"
137	AV-80-480W	1	Hose, 3/4" I.D. x 91"
138	N-80-479W	1	Hose, 3/4" I.D. x 34"
139	M-80-571W	1	Hose, 1-1/4" I.D. x 57"
141	V-80-571W	1	Hose, 1-1/4" I.D. x 73"
142	F-80-592W	1	Hose, 1-1/4" I.D. x 44"
143	23P99	1	Elbow, 90° - 1/2" T. x 3/4"-16 Str. Thd.
144	BZ-80-491W	1	Hose, 3/8" I.D. x 41"
145	23R04	1	Connector, 3/8" T. x 3/4"-16 Str. Thd.
146	15C75	1	Plug, 1-3/16"-12 Str. Thd. w/ O-Ring
147	23C66	2	Fitting, 1/8" N.P.T.F. x 90°
148	23C60	2	Fitting, 1/8" N.P.T.F., Str.
149	BT-80-491W	1	Hose, 3/8" I.D. x 104"
150	10E10	16	3/8" x 1-1/4" Hex Head Cap Screw
151	27L78	16	3/8" Lock Washer
201	X-80-482W	2	Hose, 3/3" I.D. x 80"
202	BK-80-491W	1	Hose, 3/8" I.D. x 71"
203	L-80-482W	1	Hose, 3/8" I.D. x 29"
204	L-80-479W	1	Hose, 3/4" I.D. x 30"
206	A5-80-491W	2	Hose, 3/8" I.D. x 51" (For Auto Grade Control)
207	R-80-482W	4	Hose, 3/8" I.D. x 48"
208	BZ-80-482W	2	Hose, 3/8" I.D. x 71"
	11P81	30	Tie, Plastic Wire
	10B23	15	Tie, Plastic Wire
211	DW-80-491W	1	Hose, 3/8" I.D. x 39"
212	BY-80-491W	1	Hose, 3/8" I.D. x 66"
213	BG-80-491W	2	Hose, 3/8" I.D. x 16"
214	23F70	2	Nut, 1/2" T.
215	26J12	2	Reducer, 1/2" T. x 3/8" T.
216	23H41	2	Elbow, 90° - 3/4" T. x 1-1/16"-12 Thd., O-Ring
217	ES-80-484W	1	Hose, 1/4" I.D. x 37"
218	ET-80-484W	1	Hose, 1/4" I.D. x 17"
219	AN-80-490W	1	Hose, 1/4" I.D. x 77"
220	AP-80-490W	1	Hose, 1/4" I.D. x 48"
221	N-80-508W	1	Hose, 3/4" I.D. x 78"
222	J-876-4628	2	Spacer, 3/8" Belting
223	27L58	6	1/2" Cut Washer
224	AR-80-490W	1	Hose, 1/4" I.D. x 33"
225	L-80-508W	1	Hose, 3/4" I.D. x 68"
226	EV-80-484W	2	Hose, 1/4" I.D. x 42"
227	11V33	1	Connector, 1" T. x 1-5/8"-12 Thd., O-Ring
228	16R42	2	U-Bolt
230	20K38	1	Clamp
232	27C95	3	1/2" Hex Nut
233	23N59	1	Connector, 1" Tube x 1" N.P.T.F.
234	12T27	1	Plug, 1" Tube
235	D-80-509W	1	Hose, 1" I.D. x 37"

REF.	PART NUMBER	QTY.	DESCRIPTION
236	GO-17-26	2	Pin, 3/4" Dia. x 4-1/2"
237	27K98	2	1/4" x 1/2" Socket Head Set Screw
238	ZQ-17-25	2	Pin, 1" Dia. x 3-3/4"
241	27D64	4	Pin, Cotter - 3/16" x 1-1/2"
242	B-53-1794	2	Gasket
243	13J37	9	1/2" x 1-3/4" Hex Head Cap Screw
244	C-17-478	8	Washer, 17/32" I.D. x 1" O.D. x 1/4" Thick
245	A-53-2517	4	Gasket
246	26E29	10	1/2" x 1-1/2" Hex Head Cap Screw
247	27L81	19	1/2" Lock Washer

a - Consult Barber-Greene Repair Parts Department for repairs on this item.

TRACTOR HYDRAULICS
(Hydraulic Tank Assembly)
(Illustration 1 of 2)

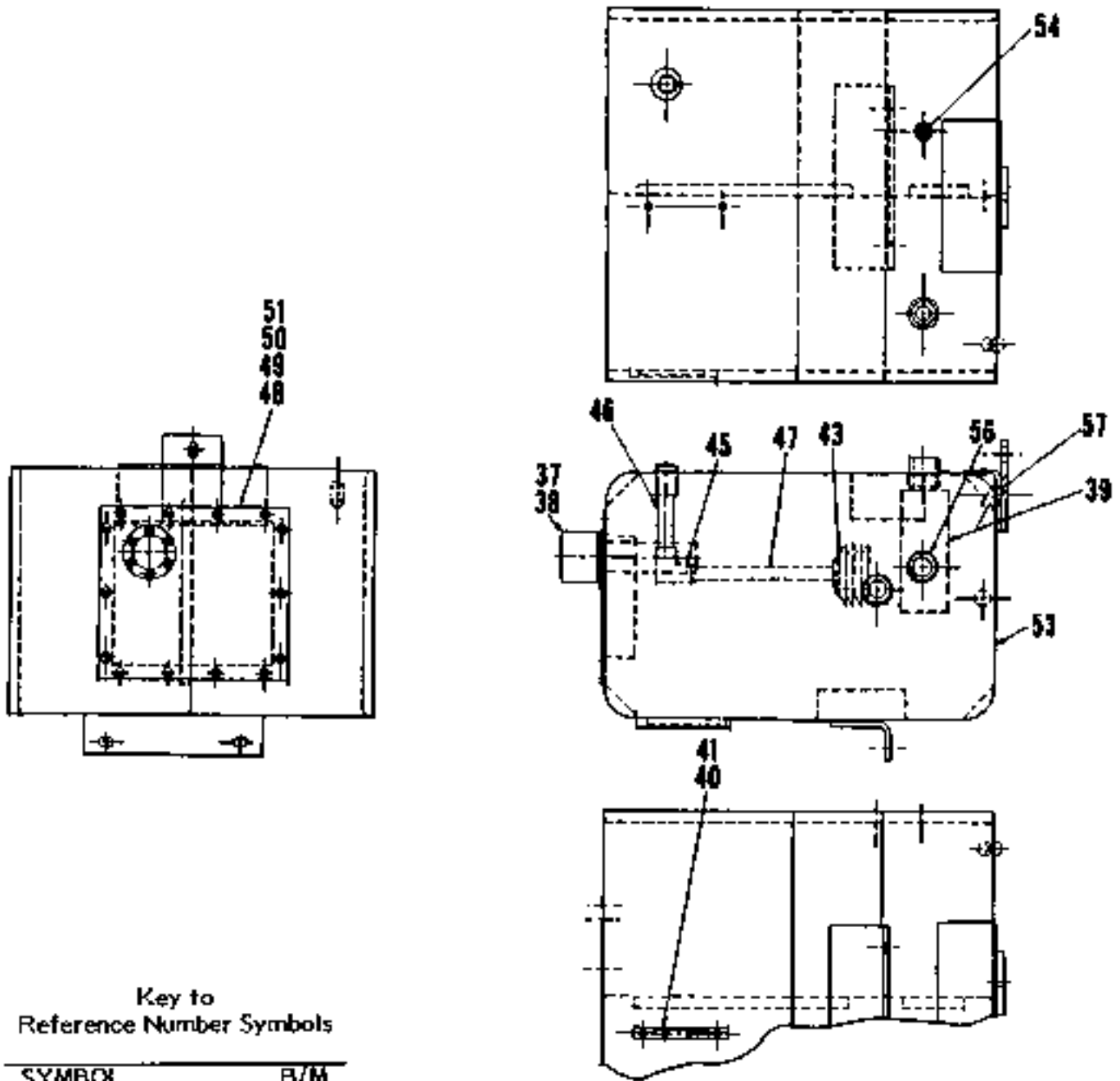

Key to
Reference Number Symbols

SYMBOL	B/M
--------	-----

NONE = A5-876-5480B (Tractor Hydraulics)

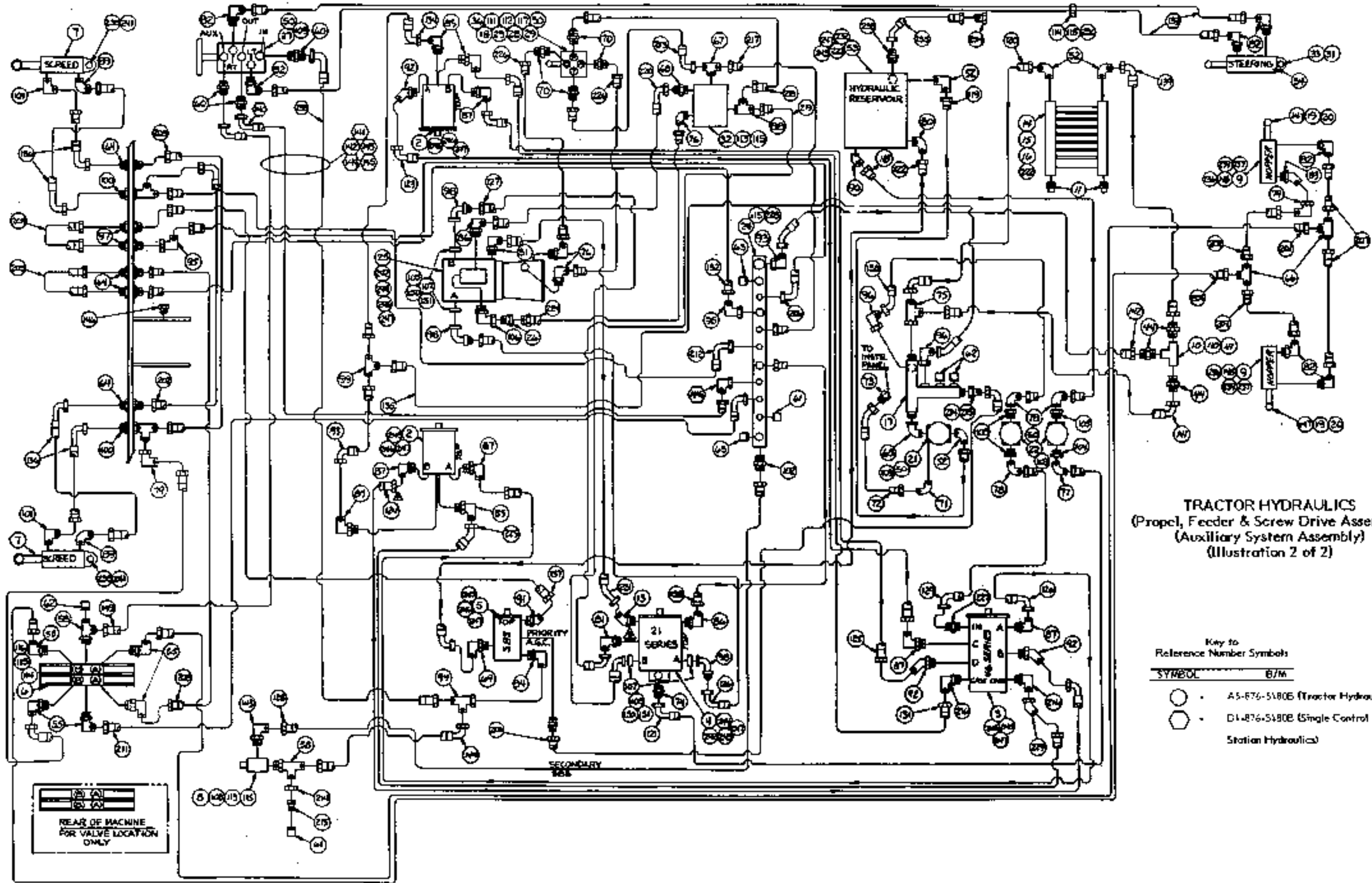

TRACTOR HYDRAULICS
 (Propel, Feeder & Screw Drive Assembly)
 (Auxiliary System Assembly)
 (Illustration 2 of 2)

- Key to Reference Number Symbols
- | SYMBOL | B/M |
|--------|---|
| ○ | A5-876-5180B (Tractor Hydraulic) |
| ◻ | D1-876-5180B (Single Control Station Hydraulic) |

TRACTOR HYDRAULICS

A5-876-54803

(Before Ordering, Consult Table of Contents to Verify Proper Bill of Material Number.)

REF.	PART NUMBER	QTY.	DESCRIPTION
Ref. #2 thru #247 Symbolized by NONE on Illustration 1 and			
Also Symbolized by  on Illustration 2.			
2	28N95	2	Motor, Hydraulic (Feeder & Screw) (See Section 12 For Breakdown)
3	a 28W80	1	Pump, Hydraulic (Feeder & Screw Tandem)
4	28G25	1	Pump, Hydraulic (Propel) (With Hydra Transmission Valve) (See Section 12 For Breakdown)
5	27X33	1	Pump, Hydraulic (SBS) (Screed Lift, Hopper Cylinders & Steering) (See Section 12 For Breakdown)
6	15K55	1	Valve (Screed Lift, Hopper Cylinders & Steering) (See Section 12 For Breakdown)
7	28L43	2	Cylinder, Hydraulic (Screed Lift) (See Section 12 For Breakdown)
8	28N77	1	Valve, Relief
9	27V85	2	Cylinder, Hydraulic (Hopper) (See Section 12 For Breakdown)
10	28W01	1	Valve, Thermal Bypass
11	23P25	2	Plug, 1-1/4" N.P.T.
	10A06	1	Trim, Plastic x 2'-0" (Quickedge)
13	12Z35	1	Elbow, 45° - 3/4" T. x 7/8"-14 Str. Thd.
14	15X46	1	Cooler, Oil
15	14D76	1	Kit, Cooler Mounting
16	BD-876-5283	2	Strap, Spacer
17	A1-80-556W	1	Manifold, Hydraulic
18	13J54	2	1/4" Lock Nut
19	A-876-5282W	2	Pin, Hopper Cylinder
20	26B08	2	3/8" x 3/4" Socket Head Set Screw
21	16W35	1	Filter (Return) (Consisting in part of the following indented item):
	16X52	1	• Element, Filter
22	16W34	2	Filter (Charge) (Consisting in part of the following indented item):
	16X52	1	• Element, Filter
23	27L59	4	#10 Lock Washer
24	A1-80-567W	1	Manifold (Return)
25	a 27Y30	1	Motor, Hydraulic (Propel)
26	27Y33	1	Fitting, Orifice
27	27Y29	1	Steering Unit
28	28J08	4	#10-24 x 2" Socket Head Cap Screw
29	27Y31	1	Valve, Shift
30	27Y32	1	Subplate
31	A-46-2207	1	1"-8 x 2-1/2" Ferry Head Cap Screw (Drilled Head)
32	27X16	1	Valve, Solenoid (See Section 12 For Breakdown)

9/4/87 (1-14) (2-12)

(Continued)

REF.	PART NUMBER	QTY.	DESCRIPTION
33	F-17-478	1	1-1/32" I.D. x 2" O.D. x 1/4" Thick Washer
34	28M35	1	Cylinder, Hydraulic (Steering) (See Section 12 For Breakdown)
36	B-876-5483	1	Plate, Valve Mounting
37	26B80	6	#10-24 x 1/2" Self Tapping Screw
38	28F47	1	Breather (Filler)
39	31L98	1	Strainer, Suction
40	10P30	1	Gauge, Level
41	27D20	2	1/2"-20 Nut
43	16W28	1	Diffuser
44	10P73	3	Connector, 1-1/4" T. x 1-5/16"-12 Str. Thd., O-Ring
45	G-80-85	1	Elbow, 1-1/4"
46	DT-80-80	1	Nipple, 1-1/4" x 3-1/2"
47	K-17-125	1	Nipple, 1-1/4" x 9"
48	AC-876-5483	1	Cover, Access
49	F-876-3108	1	Gasket
50	26E25	26	5/16" x 3/4" Hex Head Cap Screw
51	26E54	14	5/16" Washer (Sealing)
52	14C38	4	Elbow, 90° - 1-1/4" T. x 1-1/4" Male N.P.T.F.
53	A1-876-5482W	1	Tank, Hydraulic
54	20M52	1	Sensor, Temperature
55	14L07	5	Elbow, 90° - 3/8" T. x 3/4"-16 Thd., O-Ring
56	23A91	1	Plug, 1" N.P.T. Pipe
57	12L57	1	Plug, 1/8" N.P.T. Pipe
58	23R60	2	Tee, 1/2" T. x 1/2" T. x 3/4"-16 Thd. O-Ring
	10C56	1	Oil, Hydraulic (45.2 Gallons)
60	23W72	3	Connector, 1/2" Tube x 9/16"-18 Thd.
61	12T24	2	Cap, 3/8" Tube
62	12T60	3	Cap, 1/2" Tube
63	23G64	2	Cap, 3/4" Tube
64	12X17	4	Bulkhead, 3/8" Tube x 3/8" Tube
65	16L59	1	Elbow, 1-1/4" St.
66	12X40	2	Tee, 3/8" Sq. Tube x 3/8" Tube
67	11K44	1	Tee, 3/8" Sq. Tee x 1/4" N.P.T.F.
68	23A06	1	Connector, 3/8" Tube x 1/4" N.P.T.F.
69	13D39	1	Elbow, 90°, 1-1/4" Tube x 1-5/8"-12 Str.
70	23P62	4	Connector, 3/8" Tube x 3/8" N.P.T.F.
71	23L84	1	Elbow, 90° - 1/4" T. x 1/8" N.P.T.F.
72	B-80-565W	1	Hose, 1/4" I.D. x 35"
73	27Y59	1	Connector, 1/4" T. x 1/8" N.P.T.F.
74	23K83	1	Connector, 3/4" Tube x 7/8"-14 Thd., O-Ring
75	14T60	1	Tee, 1-1/4" T. x 1-1/4" T. x 1-1/4" T.
76	23C20	3	Elbow, 90°, 3/8" Tube x 1/4" N.P.T.F.
77	23F29	1	Elbow, 90°, 3/4" Tube x 3/4" N.P.T.F.
78	23K04	3	Elbow, 90°, 1" Tube x 1" N.P.T.F.
79	26J03	2	Elbow, 90° - 3/8" T. x 3/8" J.I.C., Swivel
80	28G03	1	Elbow, 90°, 1-1/4" Tube x 1-1/2" N.P.T.F.
81	23N82	2	Elbow, 90°, 1/4" Tube x 7/16"-20 Thd., O-Ring
82	23P61	7	Elbow, 90°, 3/8" Tube x 9/16"-18 Thd., O-Ring
83	15J71	1	Elbow, 45° - 3/8" T. x 9/16"-18 Thd., O-Ring

REF.	PART NUMBER	QTY.	DESCRIPTION
84	23R13	1	Elbow, 90°, 1/2" Tube x 7/8"-14 Thd., O-Ring
85	28G04	4	Elbow, 90°, 3/4" Tube x 3/4"-16 Thd., O-Ring
86	13G10	2	Elbow, 90°, 3/4" Tube x 7/8"-14 Thd., O-Ring
87	23J55	5	Elbow, 90°, 1" Tube x 1-15/16"-12 Thd., O-Ring
88	15B96	1	Tee, 3/8" Sq. Tube x 1/4" N.P.T.F.
89	23R41	2	Elbow, 90°, 3/8" Tube x 1/2" N.P.T.F.
90	13M64	1	Elbow, 45°, 1" Tube x 1" N.P.T.F.
91	15J70	1	Elbow, 45°, 3/4" Tube x 1-1/16"-12 Thd., O-Ring
92	23J56	3	Elbow, 45°, 1" Tube x 1-5/16"-12 Thd., O-Ring
93	14T33	1	Elbow, 90°, 1-1/4" Tube x 1-1/4" J.I.C. Swivel
94	13J69	1	Tee, 1/2" Sq. Tube x 1/2" J.I.C. Swivel
95	26J04	2	Elbow, 90°, 3/4" Tube x 3/4" J.I.C. Swivel
96	14T34	2	Elbow, 90°, 1" Tube x 1" J.I.C. Swivel
97	12X09	2	Bulkhead, 3/4" Tube x 3/4" Tube
98	27R41	3	Elbow, 90°, 1" Tube x 1" Flange
99	14Y57	1	Tee, 1" Tube x 1" Tube x 1" Tube
100	12W74	2	Tee, Bulkhead, 3/8" Tube x 3/8" Tube 3/8" Tube
101	13K98	2	Elbow, 90°, 3/8" Tube x 1/2" Male N.P.T.F. x 1/16" Orifice
102	23H54	1	Connector, 1/2" T. x 3/4"-16 Str. Thd.
103	10D99	3	Bushing, Reducing, 1" x 1-1/4"
104	23R36	1	Bushing, Reducing, 3/4" x 1-1/4"
105	28W79	4	O-Ring
106	28G06	1	Elbow, 90°, 1/4" Swivel x 7/16"-20 Str. O-Ring
107	10E09	3	Flange, 1" Split
108	27C86	2	1/4" Hex Nut
109	27L77	12	5/16" Lock Washer
110	10E05	2	3/8" x 3.25" Hex Head Cap Screw
111	26C53	2	3/8" x 1" Hex Head Cap Screw
112	27L78	4	3/8" Lock Washer
113	16W90	4	1/4" x 2" Hex Head Cap Screw
114	13J31	5	1/4" x 3/4" Hex Head Cap Screw
115	27L76	13	1/4" Lock Washer
116	27L52	4	1/4" Cut Washer
117	27C90	2	3/8" Hex Nut
118	AD-80-509W	1	Hose, 1" I.D. x 35"
119	AB-80-513W	1	Hose, 1-1/4" I.D. x 35"
120	D-80-571W	1	Hose, 1-1/4" I.D. x 63"
121	O-80-516W	1	Hose, 3/4" I.D. x 33"
122	B-80-571W	1	Hose, 1-1/4" I.D. x 33"
123	U-80-570W	1	Hose, 1" I.D. x 96"
124	M-80-570W	1	Hose, 1" I.D. x 69"
125	BC-80-485W	1	Hose, 1" I.D. x 89"
126	AZ-80-485W	2	Hose, 1" I.D. x 63"
127	AG-80-485W	1	Hose, 1" I.D. x 60"
128	DL-80-482W	1	Hose, 3/8" I.D. x 43"
129	Y-80-510W	1	Hose, 1" I.D. x 37"
130	G-80-512W	1	Hose, 1" I.D. x 25"
131	AG-80-516W	1	Hose, 3/4" I.D. x 98"
132	AZ-80-479W	1	Hose, 3/4" I.D. x 76"

REF.	PART NUMBER	QTY.	DESCRIPTION
133	Y-80-516W	1	Hose, 3/4" I.D. x 20"
134	AJ-80-516W	1	Hose, 3/4" I.D. x 30"
135	H-80-512W	1	Hose, 1" I.D. x 41"
136	K-80-491W	4	Hose, 3/8" I.D. x 34"
137	AV-80-480W	1	Hose, 3/4" I.D. x 91"
138	N-80-479W	1	Hose, 3/4" I.D. x 34"
139	M-80-571W	1	Hose, 1-1/4" I.D. x 57"
141	V-80-571W	1	Hose, 1-1/4" I.D. x 73"
142	F-80-592W	1	Hose, 1-1/4" I.D. x 44"
143	23P99	1	Elbow, 90° - 1/2" T. x 3/4"-16 Str. Thd.
144	BZ-80-491W	1	Hose, 3/8" I.D. x 41"
146	15C75	1	Plug, 1-3/16"-12 Str. Thd. w/ O-Ring
147	23C66	2	Fitting, 1/8" N.P.T.F. x 90°
148	23C60	2	Fitting, 1/8" N.P.T.F., Str.
149	BT-80-491W	1	Hose, 3/8" I.D. x 104"
150	10E10	16	3/8" x 1-1/4" Hex Head Cap Screw
151	27L78	16	3/8" Lock Washer
201	X-80-482W	2	Hose, 3/8" I.D. x 80"
202	BK-80-491W	1	Hose, 3/8" I.D. x 71"
203	L-80-482W	1	Hose, 3/8" I.D. x 29"
204	L-80-479W	1	Hose, 3/4" I.D. x 30"
206	AS-80-491W	2	Hose, 3/8" I.D. x 51" (For Auto Grade Control)
207	R-80-482W	4	Hose, 3/8" I.D. x 48"
208	BZ-80-482W	2	Hose, 3/8" I.D. x 71"
	11P81	30	Tie, Plastic Wire
	10B23	15	Tie, Plastic Wire
211	8W-80-491W	1	Hose, 3/8" I.D. x 39"
212	8Y-80-491W	1	Hose, 3/8" I.D. x 66"
213	DH-80-491W	2	Hose, 3/8" I.D. x 18"
214	23F70	2	Nut, 1/2" T.
215	26J12	2	Reducer, 1/2" T. x 3/8" T.
216	23H41	2	Elbow, 90° - 3/4" T. x 1-1/16"-12 Thd., O-Ring
217	E5-80-484W	1	Hose, 1/4" I.D. x 37"
218	ET-80-484W	1	Hose, 1/4" I.D. x 17"
219	AN-80-490W	1	Hose, 1/4" I.D. x 77"
220	AP-80-490W	1	Hose, 1/4" I.D. x 49"
221	N-80-508W	1	Hose, 3/4" I.D. x 78"
222	J-8/6-462B	2	Spacer, 3/8" Belting
223	27L58	6	1/2" Cut Washer
224	AR-80-490W	1	Hose, 1/4" I.D. x 33"
225	L-80-508W	1	Hose, 3/4" I.D. x 68"
226	EV-80-484W	2	Hose, 1/4" I.D. x 42"
227	11V33	1	Connector, 1" T. x 1-5/8"-12 Thd., O-Ring
228	16R42	2	U-Bolt
229	27Y42	1	Elbow, 45° - 3/4" T. x 3/4" J.I.C., Swivel
230	20K38	1	Clamp
232	27C95	3	1/2" Hex Nut
233	23N59	1	Connector, 1" Tube x 1" N.P.T.F.
234	12T27	1	Plug, 1" Tube
235	D-80-509W	1	Hose, 1" I.D. x 37"

9/4/87 (1-14) (2-12)

REF.	PART NUMBER	QTY.	DESCRIPTION
236	GO-17-26	2	Pin, 3/4" Dia. x 4-1/2"
237	Z7N34	2	1/4" x 1" Square Head Set Screw
238	ZQ-17-25	2	Pin, 1" Dia. x 3-3/4"
239	Z7D13	2	1/4" Jam Nut
240	12T11	2	1/2" x 1-3/4" Flat Head Cap Screw
241	Z7D64	4	Pin, Cotter - 3/16" x 1-1/2"
242	B-53-1794	2	Gasket
243	13J37	7	1/2" x 1-3/4" Hex Head Cap Screw
244	C-17-478	8	Washer, 17/32" I.D. x 1" O.D. x 1/4" Thick
245	A-53-2517	4	Gasket
246	Z6E29	10	1/2" x 1-1/2" Hex Head Cap Screw
247	Z7L81	19	1/2" Lock Washer

a - Consult Barber-Greene Repair Parts Department for repairs on this item.

TRACTOR HYDRAULICS
 (Hydraulic Tank Assembly)
 (Illustration 1 of 2)

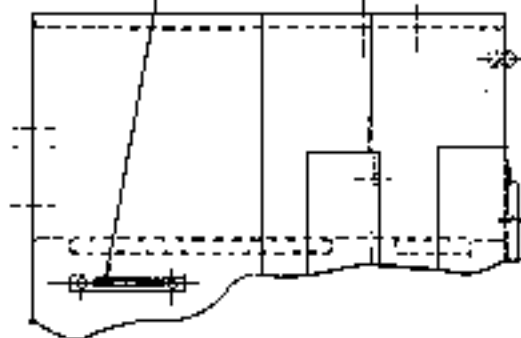
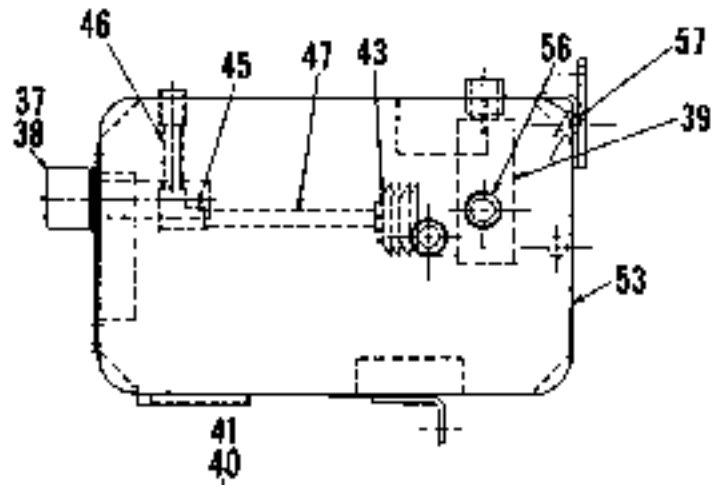
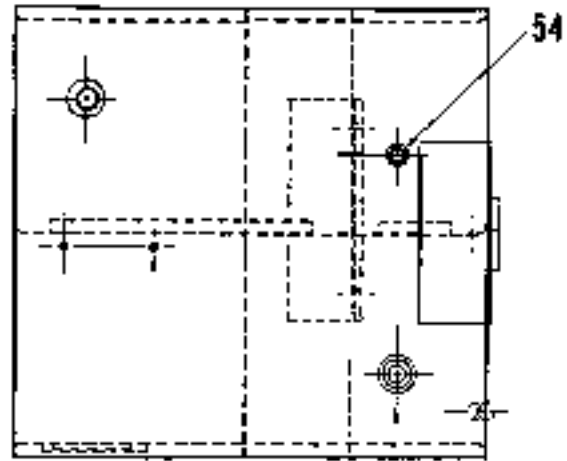
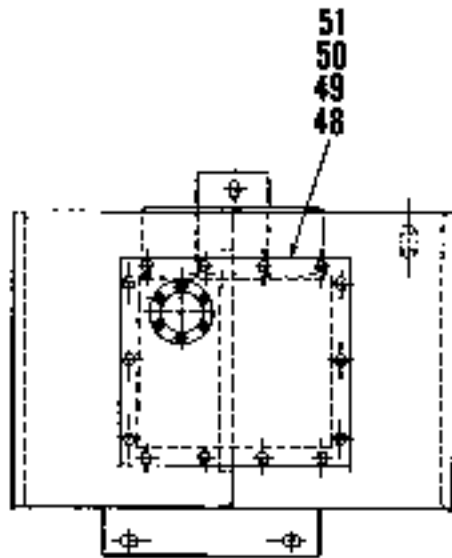

Key to
 Reference Number Symbols

SYMBOL	B/M
--------	-----

NONE = A6-876-54808 (Tractor Hydraulics)

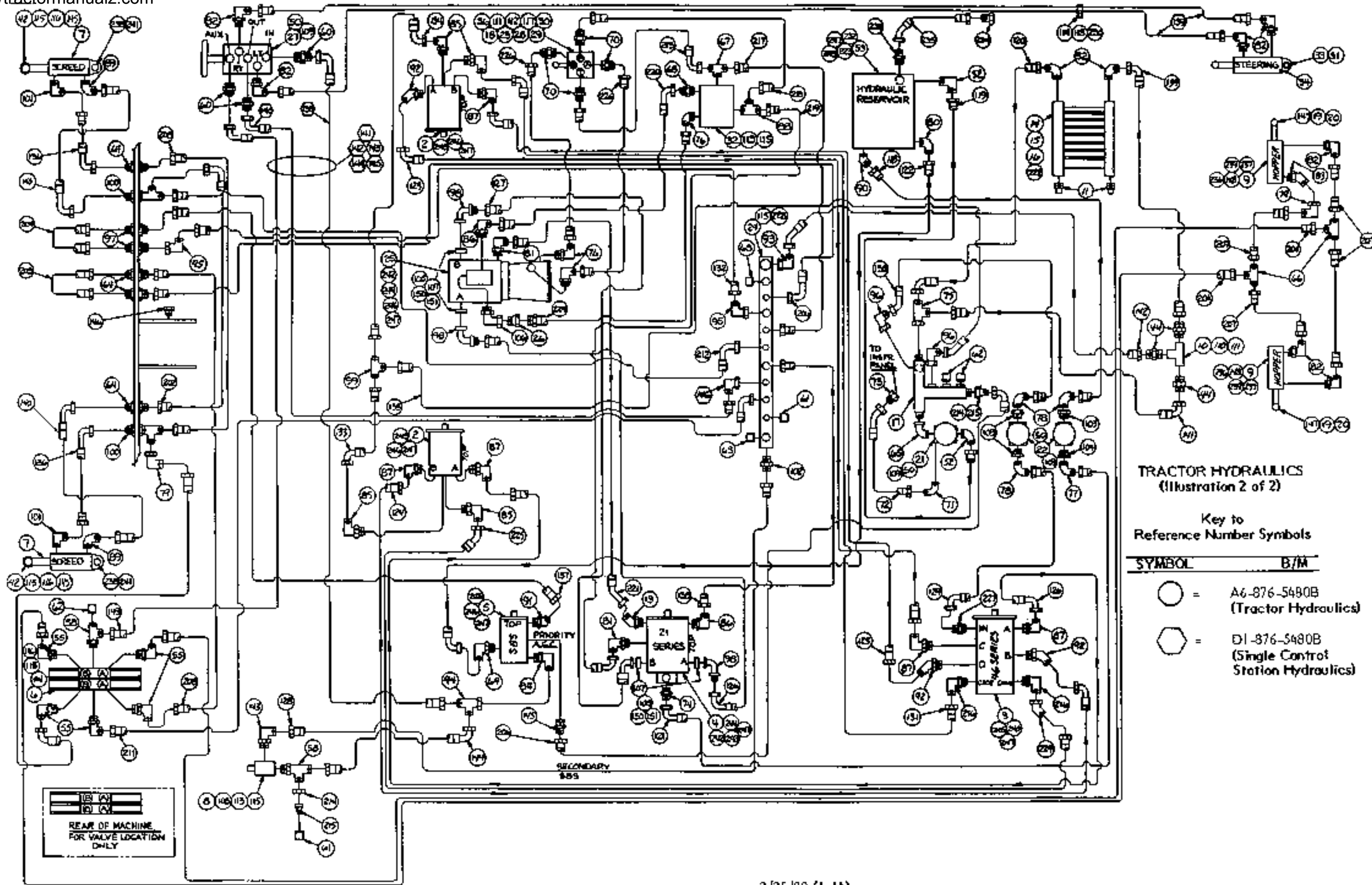

TRACTOR HYDRAULICS

A6-876-5480B

(Before Ordering, Consult Table of Contents to Verify Proper Bill of Material Number.)

REF.	PART NUMBER	QTY.	DESCRIPTION
------	-------------	------	-------------

Ref. #2 thru #247 Symbolized by NONE on Illustration 1 and

Also Symbolized by  on Illustration 2.

2	28N95	2	Motor, Hydraulic (Feeder & Screw) (See Section 12 For Breakdown)
3 a	28W80	1	Pump, Hydraulic (Feeder & Screw Tandem)
4	28G25	1	Pump, Hydraulic (Propel) (With Hydro Transmission Valve) (See Section 12 For Breakdown)
5	27X33	1	Pump, Hydraulic (SBS) (Screed Lift, Hopper Cylinders & Steering) (See Section 12 For Breakdown)
6	15K55	1	Valve (Screed Lift, Hopper Cylinders & Steering) (See Section 12 For Breakdown)
7 a	28Y79	2	Cylinder, Hydraulic (Screed Lift)
8	28N77	1	Valve, Relief
9	27V85	2	Cylinder, Hydraulic (Hopper) (See Section 12 For Breakdown)
10	28W01	1	Valve, Thermal Bypass
11	23P25	2	Plug, 1-1/4" N.P.T.
	10A06	1	Trim, Plastic x 2'-0" (Quickedge)
13	12Z35	1	Elbow, 45° - 3/4" T. x 7/8"-1 1/4" Str. Thd.
14	15X46	1	Cooler, Oil
15	14D76	1	Kit, Cooler Mounting
16	B0-876-5283	2	Strap, Spacer
17	A1-80-556W	1	Manifold, Hydraulic
18	13J54	2	1/4" Lock Nut
19	A-876-5282W	2	Pin, Hopper Cylinder
20	26B08	2	3/8" x 3/4" Socket Head Set Screw
21	16W35	1	Filter (Return) (Consisting in part of the following indented item):
	16X52	1	. Element, Filter
22	16W34	2	Filter (Charge) (Consisting in part of the following indented item):
	16X52	1	. Element, Filter
23	27L99	4	#10 Lock Washer
24	A1-80-567W	1	Manifold (Return)
25 a	27Y30	1	Motor, Hydraulic (Propel)
26	27Y33	1	Fitting, Orifice
27	27Y29	1	Steering Unit
28	28J08	4	#10-24 x 2" Socket Head Cap Screw
29	27Y31	1	Valve, Shift
30	27Y32	1	Subplate
31	A-46-2207	1	1"-8 x 2-1/2" Ferty Head Cap Screw (Drilled Head)
32	27X16	1	Valve, Solenoid (See Section 12 For Breakdown)
33	F-17-478	1	1-1/32" I.D. x 2" O.D. x 1/4" Thick Washer

2/25/89 (1-15) (2-13)

SECTION 10 PAGE 24

(Continued)

REF.	PART NUMBER	QTY.	DESCRIPTION
34	28M35	1	Cylinder, Hydraulic (Steering) (See Section 12 For Breakdown)
36	B-876-5483	1	Plate, Valve Mounting
37	26B80	6	#10-24 x 1/2" Self Tapping Screw
38	28F47	1	Breather (Filler)
39	31L98	1	Strainer, Suction
40	10P30	1	Gauge, Level
41	27D20	2	1/2"-20 Nut
42	LB-876-5592W	2	Pin, Cylinder
43	16W28	1	Diffuser
44	10P73	3	Connector, 1-1/4" T. x 1-5/16"-12 Str. Thd., O-Ring
45	G-80-85	1	Elbow, 1-1/4"
46	DT-80-80	1	Nipple, 1-1/4" x 3-1/2"
47	K-17-125	1	Nipple, 1-1/4" x 9"
48	AC-876-5483	1	Cover, Access
49	F-876-3108	1	Gasket
50	26E25	26	5/16" x 3/4" Hex Head Cap Screw
51	26F54	14	5/16" Washer (Sealing)
52	14C38	4	Elbow, 90° - 1-1/4" T. x 1-1/4" Male N.P.T.F.
53	AI-876-5482W	1	Tank, Hydraulic
54	20M52	1	Sensor, Temperature
55	14L07	5	Elbow, 90° - 3/8" T. x 3/4"-16 Thd., O-Ring
56	23A81	1	Plug, 1" N.P.T. Pipe
57	12L57	1	Plug, 1/8" N.P.T. Pipe
58	23R60	2	Tee, 1/2" T. x 1/2" T. x 3/4"-16 Thd. O-Ring
	10C56	1	Oil, Hydraulic (45.2 Gallons)
60	23W72	3	Connector, 1/2" Tube x 9/16"-18 Thd.
61	12T24	2	Cap, 3/8" Tube
62	12T60	3	Cap, 1/2" Tube
63	23G64	2	Cap, 3/4" Tube
64	12X17	4	Bulkhead, 3/8" Tube x 3/8" Tube
65	16L59	1	Elbow, 1-1/4" St.
66	12X40	2	Tee, 3/8" Sq. Tube x 3/8" Tube
67	11K44	1	Tee, 3/8" Sq. Tee x 1/4" N.P.T.F.
68	23A06	1	Connector, 3/8" Tube x 1/4" N.P.T.F.
69	13D39	1	Elbow, 90°, 1-1/4" Tube x 1-5/8"-12 Str.
70	23P62	4	Connector, 3/8" Tube x 3/8" N.P.T.F.
71	23L84	1	Elbow, 90° - 1/4" T. x 1/8" N.P.T.F.
72	B-80-565W	1	Hose, 1/4" I.D. x 35"
73	27Y59	1	Connector, 1/4" T. x 1/8" N.P.T.F.
74	23K83	1	Connector, 3/4" Tube x 7/8"-14 Thd., O-Ring
75	14T60	1	Tee, 1-1/4" T. x 1-1/4" T. x 1-1/4" T.
76	23C20	3	Elbow, 90°, 3/8" Tube x 1/4" N.P.T.F.
77	23F29	1	Elbow, 90°, 3/4" Tube x 3/4" N.P.T.F.
78	23K04	3	Elbow, 90°, 1" Tube x 1" N.P.T.F.
79	26J03	2	Elbow, 90° - 3/8" T. x 3/8" J.I.C., Swivel
80	28G03	1	Elbow, 90°, 1-1/4" Tube x 1-1/2" N.P.T.F.
81	23N82	2	Elbow, 90°, 1/4" Tube x 7/16"-20 Thd., O-Ring
82	23P61	7	Elbow, 90°, 3/8" Tube x 9/16"-18 Thd., O-Ring
83	15J71	1	Elbow, 45° - 3/8" T. x 9/16"-18 Thd., O-Ring

REF.	PART NUMBER	QTY.	DESCRIPTION
84	23R13	1	Elbow, 90°, 1/2" Tube x 7/8"-14 Thd., O-Ring
85	28G04	4	Elbow, 90°, 3/4" Tube x 3/4"-16 Thd.,- O-Ring
86	13G10	2	Elbow, 90°, 3/4" Tube x 7/8"-14 Thd.,- O-Ring
87	23J55	5	Elbow, 90°, 1" Tube x 1-5/16"-12 Thd.,- O-Ring
88	15B96	1	Tee, 3/8" Sq. Tube x 1/4" N.P.T.F.
89	23R41	2	Elbow, 90°, 3/8" Tube x 1/2" N.P.T.F.
90	13M64	1	Elbow, 45°, 1" Tube x 1" N.P.T.F.
91	15J70	1	Elbow, 45°, 3/4" Tube x 1-1/16"-12 Thd.,- O-Ring
92	23J56	3	Elbow, 45°, 1" Tube x 1-5/16"-12 Thd.,- O-Ring
93	14T33	1	Elbow, 90°, 1-1/4" Tube x 1-1/4" J.I.C. Swivel
94	13J69	1	Tee, 1/2" Sq. Tube x 1/2" J.I.C. Swivel
95	26J04	2	Elbow, 90°, 3/4" Tube x 3/4" J.I.C. Swivel
96	14T34	2	Elbow, 90°, 1" Tube x 1" J.I.C. Swivel
97	12X09	2	Bulkhead, 3/4" Tube x 3/4" Tube
98	27R41	3	Elbow, 90°, 1" Tube x 1" Flange
99	14Y57	1	Tee, 1" Tube x 1" Tube x 1" Tube
100	12W74	2	Tee, Bulkhead, 3/8" Tube x 3/8" Tube 3/8" Tube
101	13K98	2	Elbow, 90°, 3/8" Tube x 1/2" Male N.P.T.F. x 1/16" Drifce
102	23H54	1	Connector, 1/2" T. x 3/4"-16 Str. Thd.
103	10D99	3	Bushing, Reducing, 1" x 1-1/4"
104	23R36	1	Bushing, Reducing, 3/4" x 1-1/4"
105	28W79	4	O-Ring
106	28G06	1	Elbow, 90°, 1/4" Swivel x 7/16"-20 Str. O-Ring
107	10F09	8	Flange, 1" Split
108	27C96	2	1/4" Hex Nut
109	27L77	12	5/16" Lock Washer
110	10E05	2	3/8" x 3.25" Hex Head Cap Screw
111	26C53	2	3/8" x 1" Hex Head Cap Screw
112	27L78	4	3/8" Lock Washer
113	16W90	4	1/4" x 2" Hex Head Cap Screw
114	13J31	5	1/4" x 3/4" Hex Head Cap Screw
115	27L76	15	1/4" Lock Washer
116	27L52	6	1/4" Cut Washer
117	27C90	2	3/8" Hex Nut
118	AD-80-509W	1	Hose, 1" I.D. x 35"
119	AB-80-513W	1	Hose, 1-1/4" I.D. x 35"
120	D-80-571W	1	Hose, 1-1/4" I.D. x 63"
121	D-80-516W	1	Hose, 3/4" I.D. x 33"
122	B-80-571W	1	Hose, 1-1/4" I.D. x 33"
123	D-80-570W	1	Hose, 1" I.D. x 96"
124	M-80-570W	1	Hose, 1" I.D. x 68"
125	BG-80-485W	1	Hose, 1" I.D. x 89"
126	AZ-80-485W	2	Hose, 1" I.D. x 63"
127	AG-80-485W	1	Hose, 1" I.D. x 60"
128	DL-80-482W	1	Hose, 3/8" I.D. x 43"
129	Y-80-510W	1	Hose, 1" I.D. x 37"
130	G-80-512W	1	Hose, 1" I.D. x 25"
131	AG-80-516W	1	Hose, 3/4" I.D. x 98"
132	AZ-80-479W	1	Hose, 3/4" I.D. x 76"

REF.	PART NUMBER	QTY.	DESCRIPTION
133	Y-80-516W	1	Hose, 3/4" I.D. x 20"
134	AJ-80-516W	1	Hose, 3/4" I.D. x 30"
135	H-80-512W	1	Hose, 1" I.D. x 41"
136	R-80-491W	2	Hose, 3/8" I.D. x 34"
137	AV-80-480W	1	Hose, 3/4" I.D. x 91"
138	N-80-479W	1	Hose, 3/4" I.D. x 34"
139	M-80-571W	1	Hose, 1-1/4" I.D. x 57"
140	D-80-491W	2	Hose, 3/8" I.D. x 46"
141	V-80-571W	1	Hose, 1-1/4" I.D. x 73"
142	F-80-592W	1	Hose, 1-1/4" I.D. x 44"
143	23P99	1	Elbow, 90° - 1/2" T. x 3/4"-16 Str. Thd.
144	BZ-80-491W	1	Hose, 3/8" I.D. x 41"
145	23Y11	2	1/4" x .88" Hex Head Cap Screw
146	15C75	1	Plug, 1-3/16"-12 Str. Thd. w/ O-Ring
147	23C66	2	Fitting, 1/8" N.P.T.F. x 90°
148	23C60	2	Fitting, 1/8" N.P.T.F., Str.
149	BT-80-491W	1	Hose, 3/8" I.D. x 104"
150	10E10	16	3/8" x 1-1/4" Hex Head Cap Screw
151	27L78	16	3/8" Lock Washer
201	X-80-482W	2	Hose, 3/8" I.D. x 80"
202	BK-80-491W	1	Hose, 3/8" I.D. x 71"
203	L-80-482W	1	Hose, 3/8" I.D. x 29"
204	L-80-479W	1	Hose, 3/4" I.D. x 30"
206	AS-80-491W	2	Hose, 3/8" I.D. x 51" (For Auto Grade Control)
207	R-80-482W	4	Hose, 3/8" I.D. x 48"
208	BZ-80-482W	2	Hose, 3/8" I.D. x 71"
	IIP81	30	Tie, Plastic Wire
	10B23	15	Tie, Plastic Wire
211	BW-80-491W	1	Hose, 3/8" I.D. x 39"
212	BY-80-491W	1	Hose, 3/8" I.D. x 66"
213	DI-80-491W	2	Hose, 3/8" I.D. x 18"
214	23F70	2	Nut, 1/2" T.
215	26J12	2	Reducer, 1/2" T. x 3/8" T.
216	23H41	2	Elbow, 90° - 3/4" T. x 1-1/16"-12 Thd., O-Ring
217	ES-80-484W	1	Hose, 1/4" I.D. x 37"
218	ET-80-484W	1	Hose, 1/4" I.D. x 17"
219	AN-80-490W	1	Hose, 1/4" I.D. x 77"
220	AP-80-490W	1	Hose, 1/4" I.D. x 48"
221	N-80-508W	1	Hose, 3/4" I.D. x 78"
222	J-876-4629	2	Spacer, 3/8" Belling
223	27L58	6	1/2" Cut Washer
224	AR-80-490W	1	Hose, 1/4" I.D. x 33"
225	L-80-508W	1	Hose, 3/4" I.D. x 68"
226	EV-80-484W	2	Hose, 1/4" I.D. x 42"
227	11V33	1	Connector, 1" T. x 1-5/8"-12 Thd., O-Ring
228	16R42	2	U-Bolt
229	27Y42	1	Elbow, 45° - 3/4" T. x 3/4" J.I.C., Swivel
230	20K38	1	Clamp
232	27C95	3	1/2" Hex Nut
233	23N59	1	Connector, 1" Tube x 1" N.P.T.F.

REF.	PART NUMBER	QTY.	DESCRIPTION
234	12T27	1	Plug, 1" Tube
235	D-80-509W	1	Hose, 1" I.D. x 37"
236	GO-17-26	2	Pin, 3/4" Dia. x 4-1/2"
237	27N34	2	1/4" x 1" Square Head Set Screw
238	ZQ-17-25	2	Pin, 1" Dia. x 3-3/4"
239	27D13	2	1/4" Jam Nut
240	12T11	2	1/2" x 1-3/4" Flat Head Cap Screw
241	27D64	4	Pin, Cotter - 3/16" x 1-1/2"
242	B-53-1794	2	Gasket
243	13J37	7	1/2" x 1-3/4" Hex Head Cap Screw
244	C-17-478	8	Washer, 17/32" I.D. x 1" O.D. x 1/4" Thick
245	A-53-2517	4	Gasket
246	26E29	10	1/2" x 1-1/2" Hex Head Cap Screw
247	27L81	19	1/2" Lock Washer

a - Consult Barber-Greene Repair Parts Department for repairs on this item.

TRACTOR HYDRAULICS
(Hydraulic Tank Assembly)
(Illustration 1 of 2)

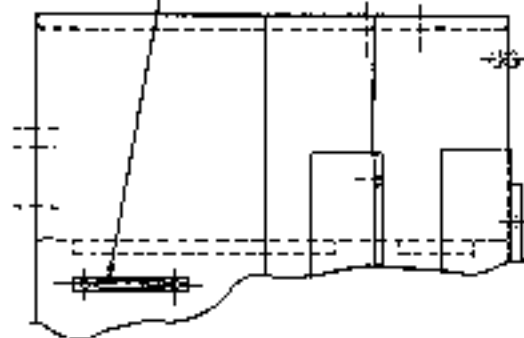
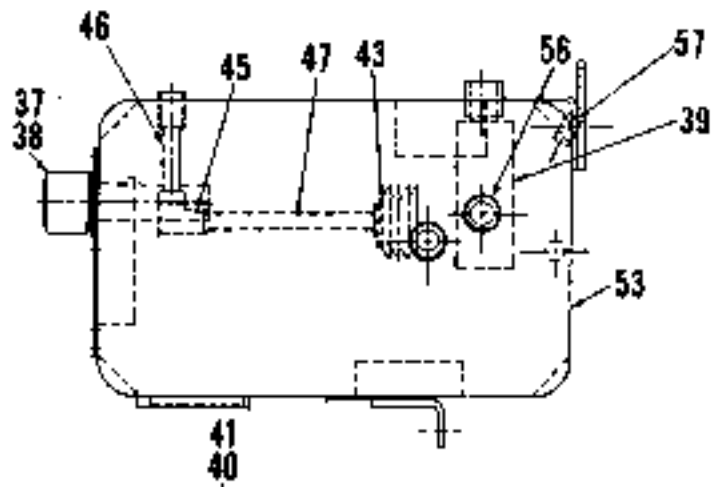
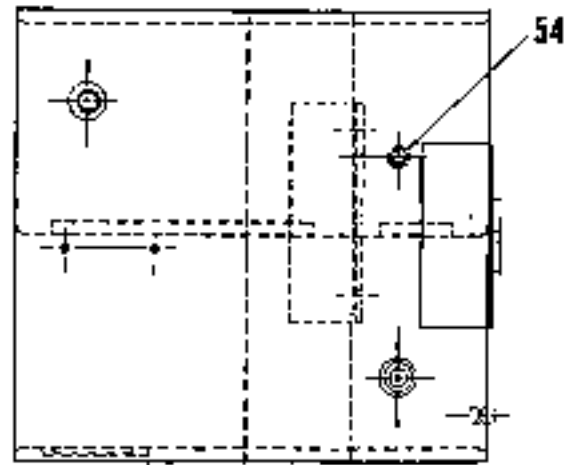
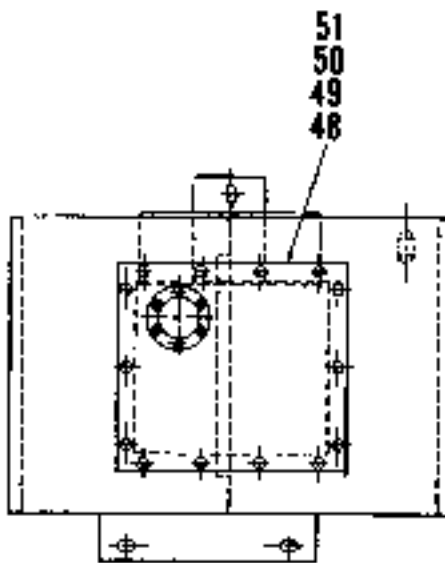

Key to
Reference Number Symbols

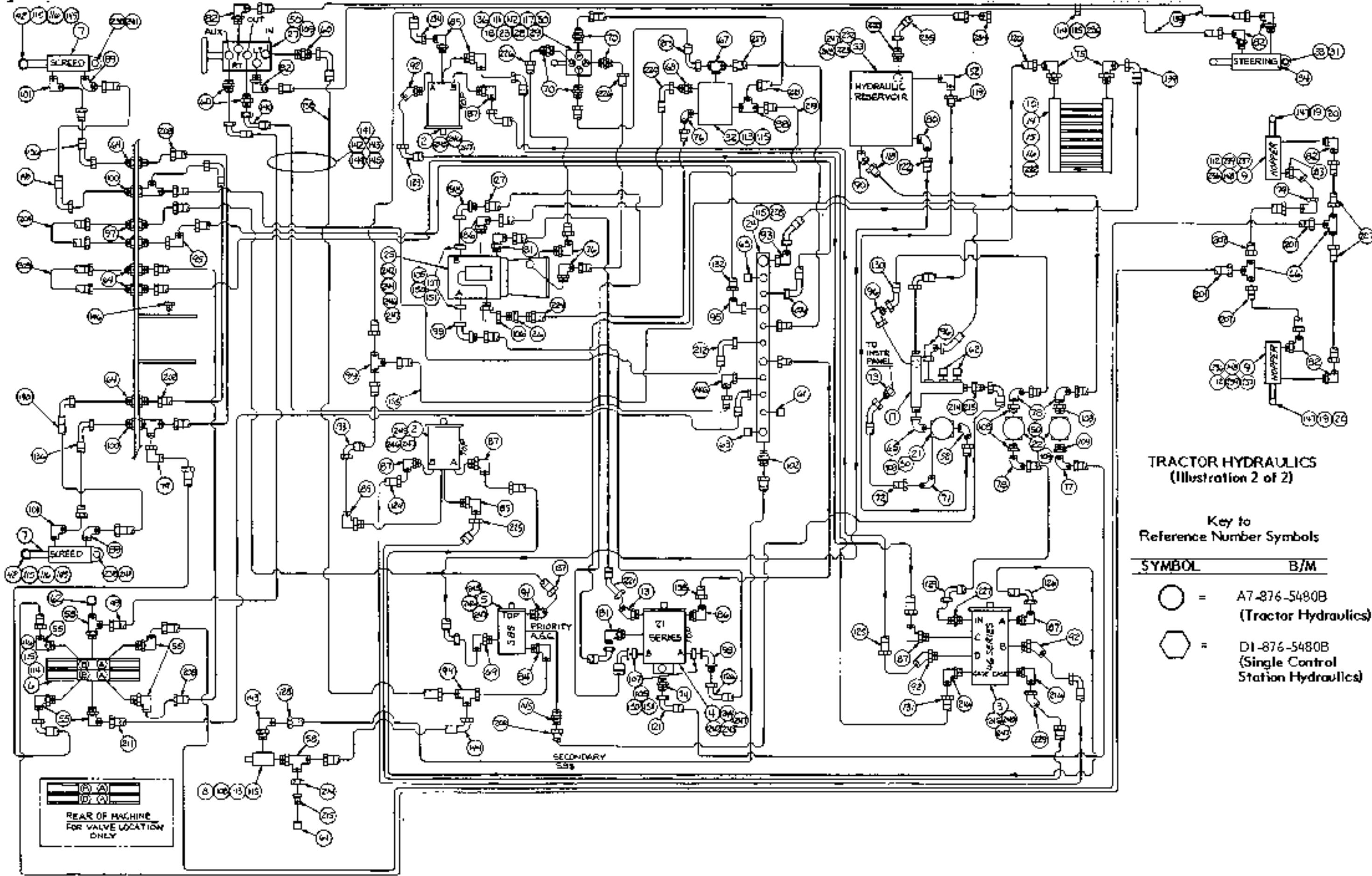

SYMBOL	B/M
--------	-----

NONE = A7-976-5480B (Tractor Hydraulics)



TRACTOR HYDRAULICS
(Illustration 2 of 2)

Key to
Reference Number Symbols

SYMBOL	B/M
	= A7-876-5480B (Tractor Hydraulics)
	= D1-876-5480B (Single Control Station Hydraulics)

 REAR OF MACHINE
 FOR VALVE LOCATION
 ONLY

TRACTOR HYDRAULICS

A7-876-5480B

(Before Ordering, Consult Table of Contents to Verify Proper Bill of Material Number.)

REF.	PART NUMBER	QTY.	DESCRIPTION
------	-------------	------	-------------

Ref. #2 thru #247 Symbolized by NONE on Illustration 1 and

Also Symbolized by  on Illustration 2.

2	28N95	2	Motor, Hydraulic (Feeder & Screw) (See Section 12 For Breakdown)
3	28W80	1	Pump, Hydraulic (Feeder & Screw Tandem)
4	28G25	1	Pump, Hydraulic (Propel) (With Hydro Transmission Valve) (See Section 12 For Breakdown)
5	27X33	1	Pump, Hydraulic (SBS) (Screed Lift, Hopper Cylinders & Steering) (See Section 12 For Breakdown)
6	15K55	1	Valve (Screed Lift, Hopper Cylinders & Steering) (See Section 12 For Breakdown)
7	28Y79	2	Cylinder, Hydraulic (Screed Lift)
8	28N77	1	Valve, Relief
9	27V85	2	Cylinder, Hydraulic (Hopper) (See Section 12 For Breakdown)
10	26K62	4	5/16" x 2.50" Hex Head Cap Screw
	10A06	1	Trim, Plastic x 2'-0" (Quickedge)
13	12Z35	1	Elbow, 45° - 3/4" T. x 7/8"-14 Str. Thd.
14	29H25	1	Cooler, Oil
15	15W48	1	Kit, Cooler Mounting
16	BD-876-5283	2	Strap, Spacer
17	A1-80-556W	1	Manifold, Hydraulic
18	13J54	2	1/4" Lock Nut
19	A-876-5282W	2	Pin, Hopper Cylinder
20	26B08	2	3/8" x 3/4" Socket Head Set Screw
21	16W35	1	Filter (Return) (Consisting in part of the following indented items):
	16X52	1	. Element, Filter
22	16W34	2	Filter (Charge) (Consisting in part of the following indented items):
	16X52	1	. Element, Filter
23	27L99	4	#10 Lock Washer
24	A1-80-567W	1	Manifold (Return)
25	27Y30	1	Motor, Hydraulic (Propel)
26	27Y33	1	Fitting, Orifice
27	27Y29	1	Steering Unit
28	28J08	4	#10-24 x 2" Socket Head Cap Screw
29	27Y31	1	Valve, Shift
30	27Y32	1	Subplate
31	A-46-2207	1	1"-8 x 2-1/2" Ferry Head Cap Screw (Drilled Head)
32	27X16	1	Valve, Solenoid (See Section 12 For Breakdown)
33	F-17-478	1	1-1/32" I.D. x 2" O.D. x 1/4" Thick Washer

2/25/89 (1-16) (2-14)

SECTION 10 PAGE 31

(Continued)

REF.	PART NUMBER	QTY.	DESCRIPTION
34	28M35	1	Cylinder, Hydraulic (Steering) (See Section 12 For Breakdown)
36	B-876-5483	1	Plate, Valve Mounting
37	26B80	6	#10-24 x 1/2" Self Tapping Screw
38	28F47	1	Breather (Filler)
39	31L98	1	Strainer, Suction
40	10P30	1	Gauge, Level
41	27D20	2	1/2"-20 Nut
42	LB-876-5592W	2	Pin, Cylinder
43	16W28	1	Diffuser
45	G-80-85	1	Elbow, 1-1/4"
46	DT-80-80	1	Nipple, 1-1/4" x 3-1/2"
47	K-17-125	1	Nipple, 1-1/4" x 9"
48	AC-876-5483	1	Cover, Access
49	F-876-3108	1	Gasket
50	26E25	26	5/16" x 3/4" Hex Head Cap Screw
51	26E54	14	5/16" Washer (Sealing)
52	14C38	2	Elbow, 90° - 1-1/4" T. x 1-1/4" Male N.P.T.F.
53	A1-876-5482W	1	Tank, Hydraulic
54	20M52	1	Sensor, Temperature
55	14L07	5	Elbow, 90° - 3/8" T. x 3/4"-16 Thd., O-Ring
56	23A81	1	Plug, 1" N.P.T. Pipe
57	12L57	1	Plug, 1/8" N.P.T. Pipe
58	23R60	2	Tee, 1/2" T. x 1/2" T. x 3/4"-16 Thd. O-Ring
	10C56	1	Oil, Hydraulic (45.2 Gallons)
60	23W72	3	Connector, 1/2" Tube x 9/16"-18 Thd.
61	12T24	2	Cap, 3/8" Tube
62	12T60	3	Cap, 1/2" Tube
63	23C64	2	Cap, 3/4" Tube
64	12X17	4	Bulkhead, 3/8" Tube x 3/8" Tube
65	16L59	1	Elbow, 1-1/4" St.
66	12X40	2	Tee, 3/8" Sq. Tube x 3/8" Tube
67	11K44	1	Tee, 3/8" Sq. Tee x 1/4" N.P.T.F.
68	23A06	1	Connector, 3/8" Tube x 1/4" N.P.T.F.
69	13D39	1	Elbow, 90°, 1-1/4" Tube x 1-5/8"-12 Str.
70	23P62	4	Connector, 3/8" Tube x 3/8" N.P.T.F.
71	23L84	1	Elbow, 90° - 1/4" T. x 1/8" N.P.T.F.
72	B-80-565W	1	Hose, 1/4" I.D. x 35"
73	27Y59	1	Connector, 1/4" T. x 1/8" N.P.T.F.
74	23K83	1	Connector, 3/4" Tube x 7/8"-14 Thd., O-Ring
75	11V34	2	Elbow, 90°, 1-1/4" T. x 1-5/8"-12 Str. Thd., O-Ring
76	23C20	3	Elbow, 90°, 3/8" Tube x 1/4" N.P.T.F.
77	23F29	1	Elbow, 90°, 3/4" Tube x 3/4" N.P.T.F.
78	23K04	3	Elbow, 90°, 1" Tube x 1" N.P.T.F.
79	26J03	2	Elbow, 90° - 3/8" T. x 3/8" J.I.C., Swivel
80	28G03	1	Elbow, 90°, 1-1/4" Tube x 1-1/2" N.P.T.F.
81	23N82	2	Elbow, 90°, 1/4" Tube x 7/16"-20 Thd., O-Ring
82	23P61	7	Elbow, 90°, 3/8" Tube x 9/16"-19 Thd., O-Ring
83	15J71	1	Elbow, 45° - 3/8" T. x 9/16"-18 Thd., O-Ring
84	23R13	1	Elbow, 90°, 1/2" Tube x 7/8"-14 Thd., O-Ring

REF.	PART NUMBER	QTY.	DESCRIPTION
85	28G04	4	Elbow, 90°, 3/4" Tube x 3/4"-16 Thd.,- O-Ring
86	13G10	2	Elbow, 90°, 3/4" Tube x 7/8"-14 Thd.,- O-Ring
87	23J55	5	Elbow, 90°, 1" Tube x 1-15/16"-12 Thd.,- O-Ring
88	15B96	1	Tee, 3/8" Sq. Tube x 1/4" N.P.T.F.
89	23R41	2	Elbow, 90°, 3/8" Tube x 1/2" N.P.T.F.
90	13M64	1	Elbow, 45°, 1" Tube x 1" N.P.T.F.
91	15J70	1	Elbow, 45°, 3/4" Tube x 1-1/16"-12 Thd.,- O-Ring
92	23J56	3	Elbow, 45°, 1" Tube x 1-5/16"-12 Thd.,- O-Ring
93	14T33	1	Elbow, 90°, 1-1/4" Tube x 1-1/4" J.I.C. Swivel
94	13J69	1	Tee, 1/2" Sq. Tube x 1/2" J.I.C. Swivel
95	26J04	2	Elbow, 90°, 3/4" Tube x 3/4" J.I.C. Swivel
96	14T34	2	Elbow, 90°, 1" Tube x 1" J.I.C. Swivel
97	12X09	2	Bulkhead, 3/4" Tube x 3/4" Tube
98	27R41	3	Elbow, 90°, 1" Tube x 1" Flange
99	14Y57	1	Tee, 1" Tube x 1" Tube x 1" Tube
100	12W74	2	Tee, Bulkhead, 3/8" Tube x 3/8" Tube 3/8" Tube
101	13K98	2	Elbow, 90°, 3/8" Tube x 1/2" Male N.P.T.F. x 1/16" Orifice
102	23H54	1	Connector, 1/2" T. x 3/4"-16 Str. Thd.
103	10D99	3	Bushing, Reducing, 1" x 1-1/4"
104	23R36	1	Bushing, Reducing, 3/4" x 1-1/4"
105	28W79	4	O-Ring
106	28G06	1	Elbow, 90°, 1/4" Swivel x 7/16"-20 Str. O-Ring
107	10E09	8	Flange, 1" Split
108	27C86	2	1/4" Hex Nut
109	27L77	12	5/16" Lock Washer
111	26C53	2	3/8" x 1" Hex Head Cap Screw
112	27L78	6	3/8" Lock Washer
113	16W90	4	1/4" x 2" Hex Head Cap Screw
114	13J31	5	1/4" x 3/4" Hex Head Cap Screw
115	27L76	15	1/4" Lock Washer
116	27L52	6	1/4" Cut Washer
117	27C90	2	3/8" Hex Nut
118	AD-80-509W	1	Hose, 1" I.D. x 35"
119	AB-80-513W	1	Hose, 1-1/4" I.D. x 35"
120	D-80-571W	1	Hose, 1-1/4" I.D. x 63"
121	D-80-516W	1	Hose, 3/4" I.D. x 33"
122	B-80-571W	1	Hose, 1-1/4" I.D. x 33"
123	D-80-570W	1	Hose, 1" I.D. x 96"
124	M-80-570W	1	Hose, 1" I.D. x 68"
125	BG-80-485W	1	Hose, 1" I.D. x 89"
126	AZ-80-485W	2	Hose, 1" I.D. x 63"
127	AG-80-485W	1	Hose, 1" I.D. x 60"
128	DL-80-492W	1	Hose, 3/8" I.D. x 43"
129	Y-80-510W	1	Hose, 1" I.D. x 37"
130	G-80-517W	1	Hose, 1" I.D. x 25"
131	AG-80-516W	1	Hose, 3/4" I.D. x 98"
132	AZ-80-479W	1	Hose, 3/4" I.D. x 76"
133	Y-80-516W	1	Hose, 3/4" I.D. x 20"
134	AJ-80-516W	1	Hose, 3/4" I.D. x 30"

REF.	PART NUMBER	QTY.	DESCRIPTION
135	H-80-512W	1	Hose, 1" I.D. x 41"
136	R-80-491W	2	Hose, 3/8" I.D. x 34"
137	AV-80-480W	1	Hose, 3/4" I.D. x 91"
138	N-80-479W	1	Hose, 3/4" I.D. x 34"
139	A-80-592W	1	Hose, 1-1/4" I.D. x 68"
140	D-80-491W	2	Hose, 3/8" I.D. x 46"
143	23P99	1	Elbow, 90° - 1/2" T. x 3/4"-16 Str. Thd.
144	BZ-80-491W	1	Hose, 3/8" I.D. x 41"
145	23Y11	2	1/4" x .88" Hex Head Cap Screw
146	15C75	1	Plug, 1-3/16"-12 Str. Thd. w/ O-Ring
147	23C66	2	Fitting, 1/8" N.P.T.F. x 90°
148	23C60	2	Fitting, 1/8" N.P.T.F., Str.
149	BT-80-491W	1	Hose, 3/8" I.D. x 104"
150	10E10	16	3/8" x 1-1/4" Hex Head Cap Screw
151	27L78	16	3/8" Lock Washer
201	X-80-482W	2	Hose, 3/8" I.D. x 80"
202	BK-80-491W	1	Hose, 3/8" I.D. x 71"
203	L-80-482W	1	Hose, 3/8" I.D. x 29"
204	L-80-479W	1	Hose, 3/4" I.D. x 30"
206	A5-90-491W	2	Hose, 3/8" I.D. x 51" (For Auto Grade Control)
207	R-80-482W	4	Hose, 3/8" I.D. x 48"
208	BZ-80-482W	2	Hose, 3/8" I.D. x 71"
	11P81	30	Tie, Plastic Wire
	10B23	15	Tie, Plastic Wire
211	BW-80-491W	1	Hose, 3/8" I.D. x 39"
212	BY-80-491W	1	Hose, 3/8" I.D. x 66"
213	DH-80-491W	2	Hose, 3/8" I.D. x 19"
214	23F70	2	Nut, 1/2" T.
215	26J12	2	Reducer, 1/2" T. x 3/8" T.
216	23H41	2	Elbow, 90° - 3/4" T. x 1-1/16"-12 Thd., O-Ring
217	ES-80-484W	1	Hose, 1/4" I.D. x 37"
218	ET-80-484W	1	Hose, 1/4" I.D. x 17"
219	AN-80-490W	1	Hose, 1/4" I.D. x 77"
220	AP-80-490W	1	Hose, 1/4" I.D. x 48"
221	N-80-508W	1	Hose, 3/4" I.D. x 78"
222	J-876-4628	2	Spacer, 3/8" Belting
223	27L58	6	1/2" Cup Washer
224	AR-80-490W	1	Hose, 1/4" I.D. x 33"
225	L-80-508W	1	Hose, 3/4" I.D. x 68"
226	EY-80-484W	2	Hose, 1/4" I.D. x 42"
227	11V33	1	Connector, 1" T. x 1-5/8"-12 Thd., O-Ring
228	16R42	2	U-Bolt
229	27Y42	1	Elbow, 45° - 3/4" T. x 3/4" J.I.C., Swivel
230	20K38	1	Clamp
232	27C95	3	1/2" Hex Nut
233	23N59	1	Connector, 1" Tube x 1" N.P.T.F.
234	12T27	1	Plug, 1" Tube
235	D-80-509W	1	Hose, 1" I.D. x 37"
236	DA-876-5283	2	Pin, 3/4" Dia. x 4-1/2"
237	26C53	4	3/8" x 1" Hex Head Cap Screw

2/25/89 (1-16) (2-14)

SECTION 10 PAGE 34

(Continued)

REF.	PART NUMBER	QTY.	DESCRIPTION
238	ZQ-17-25	2	Pin, 1" Dia. x 3-3/4"
239	DB-876-5283	2	Bar
240	1ZF11	2	1/2" x 1-3/4" Flat Head Cap Screw
241	27D64	4	Pin, Cotter - 3/16" x 1-1/2"
242	B-53-1794	2	Gasket
243	13J37	7	1/2" x 1-3/4" Hex Head Cap Screw
244	C-17-47B	8	Washer, 17/32" I.D. x 1" O.D. x 1/4" Thick
245	A-53-2517	4	Gasket
246	26E29	10	1/2" x 1-1/2" Hex Head Cap Screw
247	27L81	19	1/2" Lock Washer

a - Consult Barber-Greene Repair Parts Department for repairs on this item.

TRACTOR HYDRAULICS
(Hydraulic Tank Assembly)
(Illustration 1 of 2)

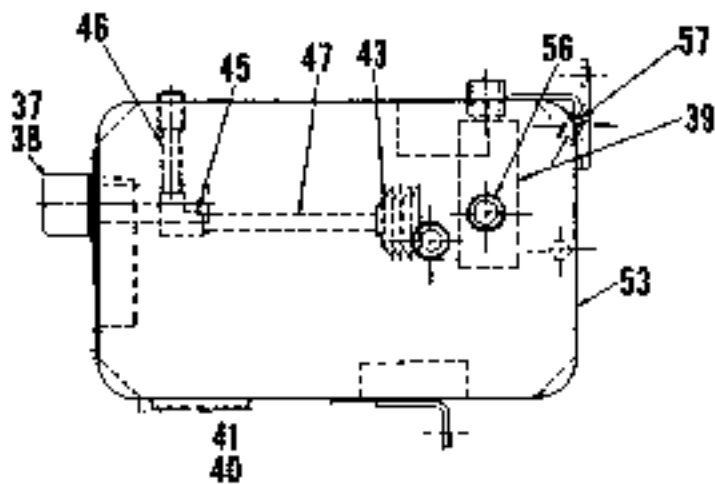
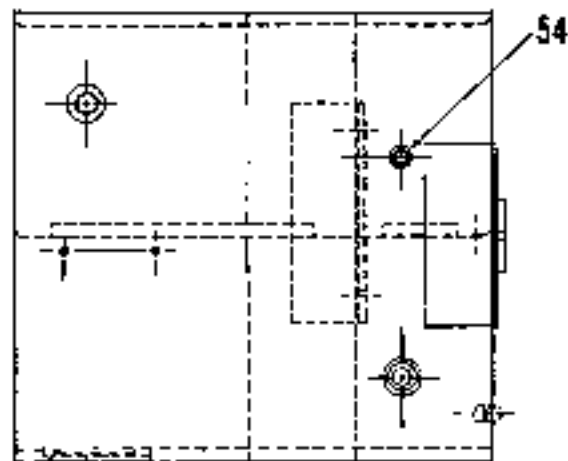
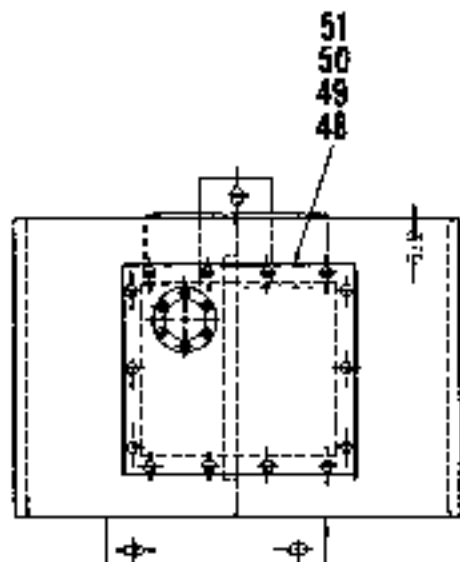

Key to
Reference Number Symbols

SYMBOL	B/M
--------	-----

NONE = A8-876-5480B (Tractor Hydraulics)

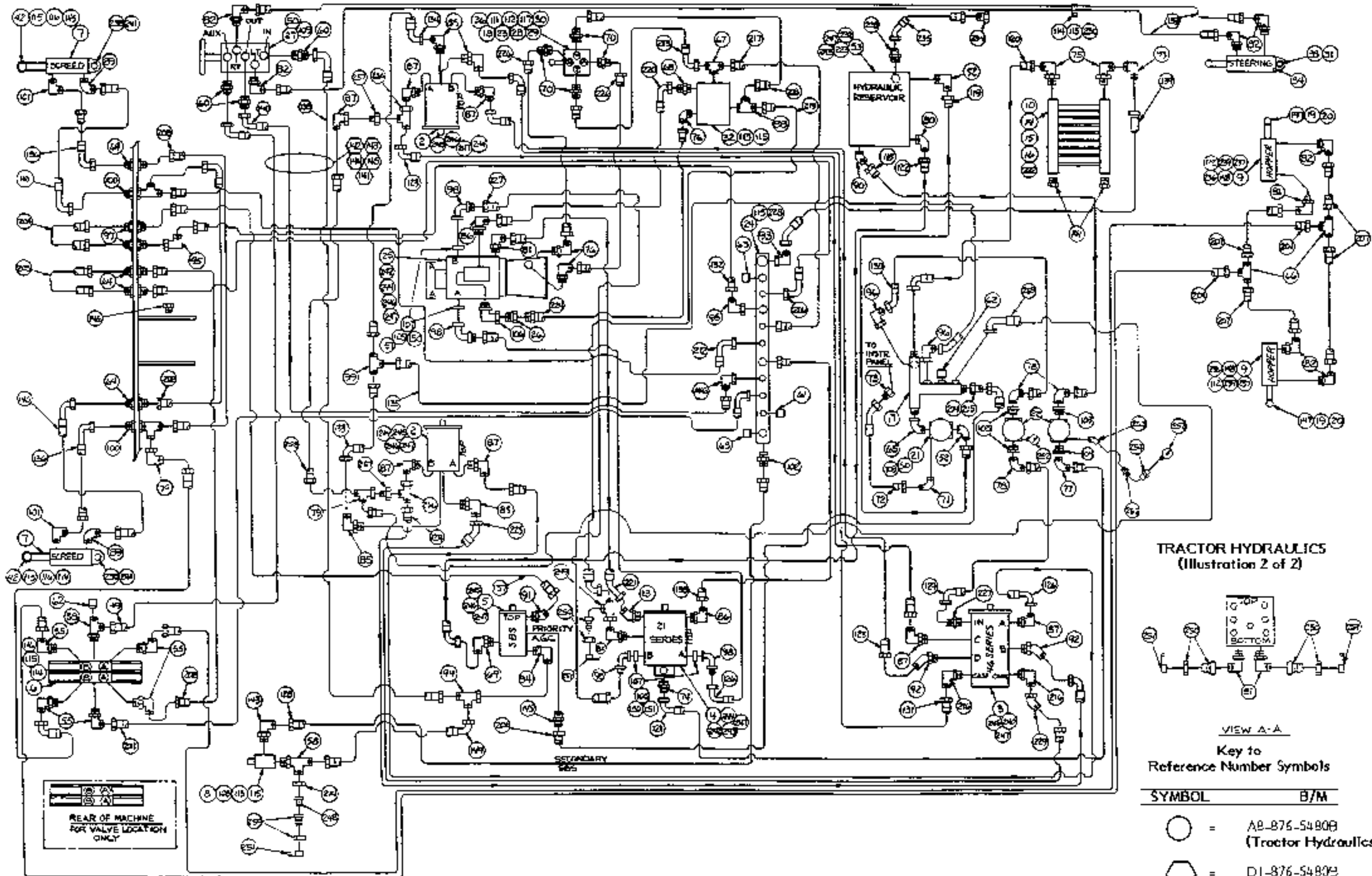

TRACTOR HYDRAULICS
(Illustration 2 of 2)

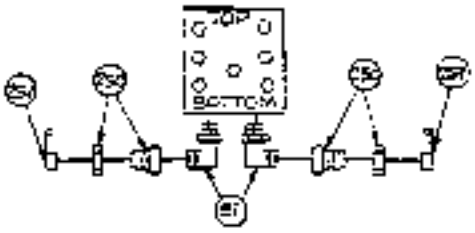

VIEW A-A

Key to
Reference Number Symbols

SYMBOL	B/M
○	AB-876-54809 (Tractor Hydraulics)
⬡	DI-876-54809 (Single Control Station Hydraulics)

TRACTOR HYDRAULICS

A8-876-5480B

(Before Ordering, Consult Table of Contents to Verify Proper Bill of Material Number.)

REF.	PART NUMBER	QTY.	DESCRIPTION
------	-------------	------	-------------

Ref. #2 thru #259 Symbolized by NONE on Illustration 1 and

Also Symbolized by  on Illustration 2.

2	28N95	2	Motor, Hydraulic (Feeder & Screw) (See Section 12 For Breakdown)
3	a 28W80	1	Pump, Hydraulic (Feeder & Screw Tandem)
4	a 29N52	1	Pump, Hydraulic (Propel)
5	27X33	1	Pump, Hydraulic (SBS) (Screed Lift, Hopper Cylinders & Steering) (See Section 12 For Breakdown)
6	15K55	1	Valve (Screed Lift, Hopper Cylinders & Steering) (See Section 12 For Breakdown)
7	a 28Y79	2	Cylinder, Hydraulic (Screed Lift)
8	28N77	1	Valve, Relief
9	27V85	2	Cylinder, Hydraulic (Hopper) (See Section 12 For Breakdown)
10	26K62	4	5/16" x 2.50" Hex Head Cap Screw
	10A06	1	Trim, Plastic x 2'-0" (Quickedge)
13	12Z35	1	Elbow, 45° - 3/4" T. x 7/8"-14 Str. Thd.
14	29HZ5	1	Cooler, Oil
15	15W48	1	Kit, Cooler Mounting
16	BD-876-5283	2	Strap, Spacer
17	A1-80-556W	1	Manifold, Hydraulic
18	13J54	2	1/4" Lock Nut
19	A-876-5282W	2	Pin, Hopper Cylinder
20	26B08	2	3/8" x 3/4" Socket Head Set Screw
21	16W35	1	Filter (Return) (Consisting in part of the following indented item):
	16X52	1	• Element, Filter
22	16W34	2	Filter (Charge) (Consisting in part of the following indented item):
	16X52	1	• Element, Filter
23	27L99	4	#10 Lock Washer
24	A1-80-567W	1	Manifold (Return)
25	a 27Y30	1	Motor, Hydraulic (Propel)
26	27Y33	1	Fitting, Orifice
27	27Y29	1	Steering Unit
28	28J08	4	#10-24 x 2" Socket Head Cap Screw
29	27Y31	1	Valve, Shift
30	27Y32	1	Subplate
31	A-46-2207	1	1"-8 x 2-1/2" Hex Head Cap Screw (Drilled Head)
32	27X16	1	Valve, Solenoid (See Section 12 For Breakdown)
33	F-17-478	1	1-1/32" I.D. x 2" O.D. x 1/4" Thick Washer
34	28M35	1	Cylinder, Hydraulic (Steering) (See Section 12 For Breakdown)

REF.	PART NUMBER	QTY.	DESCRIPTION
36	B-876-5483	1	Plate, Valve Mounting
37	26B80	6	#10-24 x 1/2" Self Tapping Screw
38	29M32	1	Breather (Filler)
39	31L98	1	Strainer, Suction
40	10P30	1	Gauge, Level
41	27D20	2	1/2"-20 Nut
42	LB-876-5597W	2	Pin, Cylinder
43	16W28	1	Diffuser
45	G-80-85	1	Elbow, 1-1/4"
46	DT-80-80	1	Nipple, 1-1/4" x 3-1/2"
47	K-17-125	1	Nipple, 1-1/4" x 9"
48	AC-876-5483	1	Cover, Access
49	F-876-3108	1	Gasket
50	26E25	26	5/16" x 3/4" Hex Head Cap Screw
51	26E54	14	5/16" Washer (Sealing)
52	14C38	2	Elbow, 90° - 1-1/4" T. x 1-1/4" Male N.P.T.F.
53	AI-876-5482W	1	Tank, Hydraulic
54	20M52	1	Sensor, Temperature
55	14L07	5	Elbow, 90° - 3/8" T. x 3/4"-16 Thd., O-Ring
56	23A81	1	Plug, 1" N.P.T. Pipe
57	12L57	1	Plug, 1/8" N.P.T. Pipe
58	23R60	2	Tee, 1/2" T. x 1/2" T. x 3/4"-16 Thd. O-Ring
	10C56	1	Oil, Hydraulic (45.2 Gallons)
60	23W72	3	Connector, 1/2" Tube x 9/16"-18 Thd.
61	12T24	2	Cap, 3/8" Tube
62	12T60	3	Cap, 1/2" Tube
63	23G64	2	Cap, 3/4" Tube
64	12X17	4	Bulkhead, 3/8" Tube x 3/8" Tube
65	16L59	1	Elbow, 1-1/4" St.
66	12X40	2	Tee, 3/8" Sq. Tube x 3/8" Tube
67	11K44	1	Tee, 3/8" Sq. Tee x 1/4" N.P.T.F.
68	23A06	1	Connector, 3/8" Tube x 1/4" N.P.T.F.
69	13D39	1	Elbow, 90°, 1-1/4" Tube x 1-5/8"-12 Str.
70	23P62	4	Connector, 3/8" Tube x 3/8" N.P.T.F.
71	23L84	1	Elbow, 90° - 1/4" T. x 1/8" N.P.T.F.
72	B-80-565W	1	Hose, 1/4" I.D. x 35"
73	27Y59	1	Connector, 1/4" T. x 1/8" N.P.T.F.
74	23K83	1	Connector, 3/4" Tube x 7/8"-14 Thd., - O-Ring
75	13D39	2	Elbow, 90°, 1-1/4" T. x 1-5/8"-12 Str. Thd., O-Ring
76	23C20	3	Elbow, 90°, 3/8" Tube x 1/4" N.P.T.F.
77	23F29	1	Elbow, 90°, 3/4" Tube x 3/4" N.P.T.F.
78	23K04	3	Elbow, 90°, 1" Tube x 1" N.P.T.F.
79	26J03	2	Elbow, 90° - 3/8" T. x 3/8" J.I.C., Swivel
80	28G03	1	Elbow, 90°, 1-1/4" Tube x 1-1/2" N.P.T.F.
81	23N82	4	Elbow, 90°, 1/4" Tube x 7/16"-20 Thd., - O-Ring
82	23P61	8	Elbow, 90°, 3/8" Tube x 9/16"-18 Thd., - O-Ring
83	15J71	1	Elbow, 45° - 3/8" T. x 9/16"-18 Thd., O-Ring
84	23R13	1	Elbow, 90°, 1/2" Tube x 7/8"-14 Thd., O-Ring
85	28G04	4	Elbow, 90°, 3/4" Tube x 3/4"-16 Thd., - O-Ring
86	13G10	2	Elbow, 90°, 3/4" Tube x 7/8"-14 Thd., - O-Ring

5/1/90 (1-20) (2-16)

(Continued)

REF.	PART NUMBER	QTY.	DESCRIPTION
87	23J55	6	Elbow, 90°, 1" Tube x 1-15/16"-12 Thd.,- O-Ring
88	15B96	1	Tee, 3/8" Sq. Tube x 1/4" N.P.T.F.
99	23R41	2	Elbow, 90°, 3/8" Tube x 1/2" N.P.T.F.
90	13M64	1	Elbow, 45°, 1" Tube x 1" N.P.T.F.
91	15J70	1	Elbow, 45°, 3/4" Tube x 1-1/16"-12 Thd.,- O-Ring
92	23J56	2	Elbow, 45°, 1" Tube x 1-5/16"-12 Thd.,- O-Ring
93	14T33	1	Elbow, 90°, 1-1/4" Tube x 1-1/4" J.I.C. Swivel
94	13J69	1	Tee, 1/2" Sq. Tube x 1/2" J.I.C. Swivel
95	26J04	2	Elbow, 90°, 3/4" Tube x 3/4" J.I.C. Swivel
96	14T34	2	Elbow, 90°, 1" Tube x 1" J.I.C. Swivel
97	12X09	2	Bulkhead, 3/4" Tube x 3/4" Tube
98	27R41	4	Elbow, 90°, 1" Tube x 1" Flange
99	14Y57	1	Tee, 1" Tube x 1" Tube x 1" Tube
100	12W74	2	Tee, Bulkhead, 3/8" Tube x 3/8" Tube 3/8" Tube
101	13K98	2	Elbow, 90°, 3/8" Tube x 1/2" Male N.P.T.F. x 1/16" Orifice
102	23H54	1	Connector, 1/2" T. x 3/4"-16 Str. Thd.
103	10D99	3	Bushing, Reducing, 1" x 1-1/4"
104	23R36	1	Bushing, Reducing, 3/4" x 1-1/4"
105	28W79	4	O-Ring
106	28G06	1	Elbow, 90°, 1/4" Swivel x 7/16"-20 Str. O-Ring
107	10E09	8	Flange, 1" Split
108	27C86	2	1/4" Hex Nut
109	27L77	12	5/16" Lock Washer
111	26C53	2	3/8" x 1" Hex Head Cap Screw
112	27L78	6	3/8" Lock Washer
113	16W90	4	1/4" x 2" Hex Head Cap Screw
114	13J31	5	1/4" x 3/4" Hex Head Cap Screw
115	27L76	15	1/4" Lock Washer
116	27L52	6	1/4" Cut Washer
117	27C90	2	3/8" Hex Nut
118	AD-80-509W	1	Hose, 1" I.D. x 35"
119	AB-80-513W	1	Hose, 1-1/4" I.D. x 35"
120	D-80-571W	1	Hose, 1-1/4" I.D. x 63"
121	D-80-516W	1	Hose, 3/4" I.D. x 33"
122	B-80-571W	1	Hose, 1-1/4" I.D. x 33"
123	AY-80-485W	1	Hose, 1" I.D. x 96"
124	BV-80-485W	1	Hose, 1" I.D. x 68"
125	BG-80-485W	1	Hose, 1" I.D. x 89"
126	AZ-80-495W	2	Hose, 1" I.D. x 63"
127	AL-80-478W	1	Hose, 1" I.D. x 57"
128	DL-80-482W	1	Hose, 3/8" I.D. x 43"
129	Y-80-510W	1	Hose, 1" I.D. x 37"
130	G-80-512W	1	Hose, 1" I.D. x 25"
131	AG-80-516W	1	Hose, 3/4" I.D. x 98"
132	AZ-80-479W	1	Hose, 3/4" I.D. x 76"
133	Y-80-516W	1	Hose, 3/4" I.D. x 20"
134	AJ-80-516W	1	Hose, 3/4" I.D. x 30"
135	H-80-512W	1	Hose, 1" I.D. x 41"
136	R-80-491W	2	Hose, 3/8" I.D. x 34"

REF.	PART NUMBER	QTY.	DESCRIPTION
137	AV-80-480W	1	Hose, 3/4" I.D. x 91"
138	N-80-479W	1	Hose, 3/4" I.D. x 34"
139	A-80-592W	1	Hose, 1-1/4" I.D. x 68"
140	D-80-491W	2	Hose, 3/8" I.D. x 46"
141	23M23	2	Plug, 1-5/8" Str. Thd., O-Ring
143	23P99	1	Elbow, 90° - 1/2" T. x 3/4"-16 Str. Thd.
144	BZ-80-491W	1	Hose, 3/8" I.D. x 41"
145	23Y11	2	1/4" x .88" Hex Head Cap Screw
146	15C75	1	Plug, 1-3/16"-12 Str. Thd. w/ O-Ring
147	23C66	2	Fitting, 1/8" N.P.T.F. x 90°
148	23C60	2	Fitting, 1/8" N.P.T.F., Str.
149	BT-80-491W	1	Hose, 3/8" I.D. x 104"
150	10E10	16	3/8" x 1-1/4" Hex Head Cap Screw
151	27L78	16	3/8" Lock Washer
201	X-80-482W	2	Hose, 3/8" I.D. x 80"
202	BK-80-491W	1	Hose, 3/8" I.D. x 71"
203	L-80-482W	1	Hose, 3/8" I.D. x 29"
204	L-80-479W	1	Hose, 3/4" I.D. x 30"
206	AS-80-491W	2	Hose, 3/8" I.D. x 51" (For Auto Grade Control)
207	R-80-482W	4	Hose, 3/8" I.D. x 48"
208	BZ-80-482W	2	Hose, 3/8" I.D. x 71"
	11P81	30	Tie, Plastic Wire
	10B23	15	Tie, Plastic Wire
211	BW-80-491W	1	Hose, 3/8" I.D. x 39"
212	BY-80-491W	1	Hose, 3/8" I.D. x 66"
213	DH-80-491W	2	Hose, 3/8" I.D. x 18"
214	23F70	2	Nut, 1/2" T.
215	26J12	1	Reducer, 1/2" T. x 3/8" T.
216	23H41	2	Elbow, 90° - 3/4" T. x 1-1/16"-12 Thd., O-Ring
217	E5-80-484W	1	Hose, 1/4" I.D. x 37"
218	ET-80-484W	1	Hose, 1/4" I.D. x 17"
219	AN-80-490W	1	Hose, 1/4" I.D. x 77"
220	AP-80-490W	1	Hose, 1/4" I.D. x 48"
221	N-80-508W	1	Hose, 3/4" I.D. x 78"
222	J-876-4628	2	Spacer, 3/8" Belting
223	27L58	6	1/2" Cut Washer
224	AR-80-490W	1	Hose, 1/4" I.D. x 33"
225	L-80-508W	1	Hose, 3/4" I.D. x 68"
226	EY-80-484W	2	Hose, 1/4" I.D. x 42"
227	11V33	1	Connector, 1" T. x 1-5/8"-12 Thd., O-Ring
228	16R42	2	U-Bolt
229	27Y42	1	Elbow, 45° - 3/4" T. x 3/4" J.I.C., Swivel
230	20K38	1	Clamp
231	23R04	1	Connector, 3/8" O.D. x 3/4"-16 Male S.A.E. Thd.
232	27C95	3	1/2" Hex Nut
233	23N59	1	Connector, 1" Tube x 1" N.P.T.F.
234	12T27	1	Plug, 1" Tube
235	D-80-509W	1	Hose, 1" I.D. x 37"
236	DA-876-5283	2	Pin, 3/4" Dia. x 4-1/2"
237	26C53	4	3/8" x 1" Hex Head Cap Screw

REF.	PART NUMBER	QTY.	DESCRIPTION
238	BU-17-25	2	Pin, 1" Dia. x 3.88"
239	DB-876-5283	2	Bar
240	12T11	2	1/2" x 1-3/4" Flat Head Cap Screw
241	27D64	4	Pin, Cotter - 3/16" x 1-1/2"
242	B-53-1794	2	Gasket
243	13J37	15	1/2" x 1-3/4" Hex Head Cap Screw
244	C-17-478	12	Washer, 17/32" I.D. x 1" O.D. x 1/4" Thick
245	A-53-2517	4	Gasket
246	26E29	2	1/2" x 1-1/2" Hex Head Cap Screw
247	27L81	19	1/2" Lock Washer
248	26J11	1	Reducer, 1/2" T. x 1/4" T.
249	27Y53	1	Tee, 1/4" T. x 1/4" T. x 7/16"-20
250	29J32	4	Nipple, Tube End
251	29F42	4	Plug, Dust
252	29E60	2	Gauge, Vacuum
253	29M31	1	Elbow, 45° - 5t. x 1/4" N.P.T.F.
254	28M75	1	Coupling, 1/4" N.P.T.F.
255	23N77	1	Nipple, 1/4" N.P.T.F.
256	23R14	2	Tee, 1" T. x 1" T. x 1-5/16-12 Swivel
257	29M91	2	Connector, Reducer (With .050" Orifice)
258	E-80-496W	1	Hose, 3/8" I.D. x 58.00"
259	K-80-497W	1	Hose, 3/8" I.D. x 52.00"

a - Consult Barber-Greene Repair Parts Department for repairs on this item.

TRACTOR HYDRAULICS
(Hydraulic Tank Assembly)
(Illustration 1 of 2)

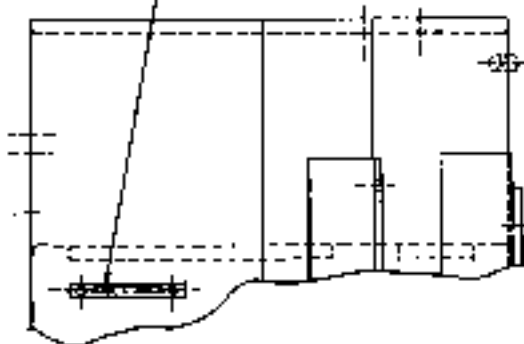
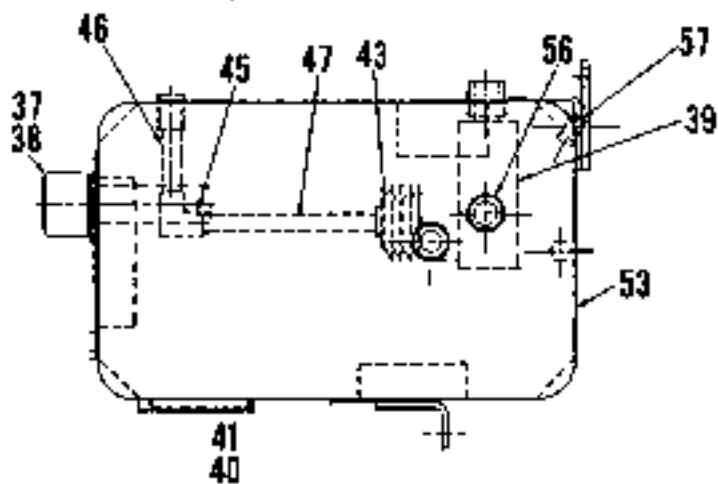
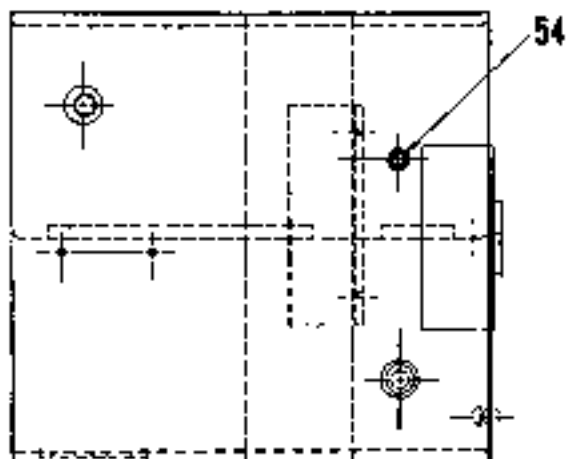
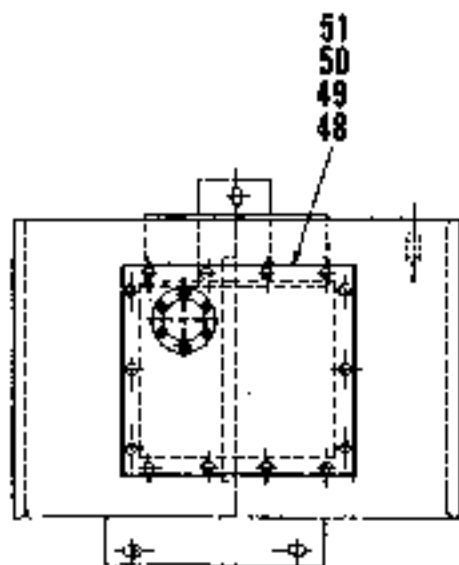

Key to
 Reference Number Symbols

SYMBOL	B/M
--------	-----

NONE = A9-876-5480B (Tractor Hydraulics)

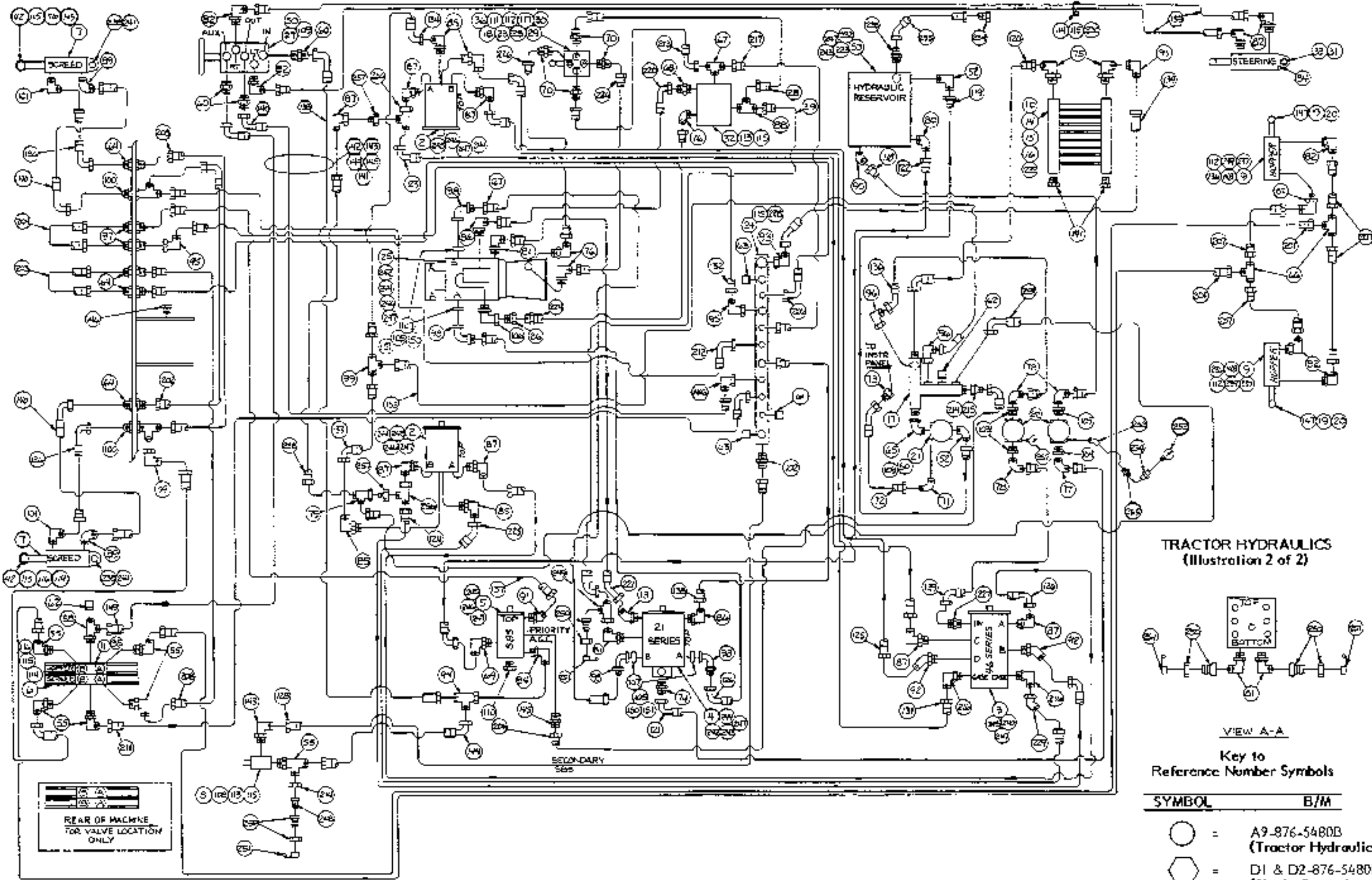

TRACTOR HYDRAULICS
(Illustration 2 of 2)

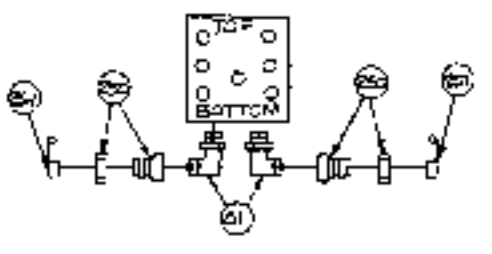

VIEW A-A

Key to
Reference Number Symbols

SYMBOL	B/M
○	A9-876-5480B (Tractor Hydraulics)
⬡	D1 & D2-876-5480B (Single Control Station Hydraulics)

TRACTOR HYDRAULICS

A9-876-5480B

(Before Ordering, Consult Table of Contents to Verify Proper Bill of Material Number.)

REF.	PART NUMBER	QTY.	DESCRIPTION
Ref. #2 thru #259 Symbolized by NONE on Illustration 1 and			
Also Symbolized by on Illustration 2.			
2	28N95	2	Motor, Hydraulic (Feeder & Screw) (See Section 12 For Breakdown)
3	a 28W90	1	Pump, Hydraulic (Feeder & Screw Tandem)
4	a 29N52	1	Pump, Hydraulic (Propel)
5	a 29P51	1	Pump, Hydraulic (SBS) (Screed Lift, Hopper Cylinders & Steering)
6	a 29R30	1	Valve (Screed)
7	a 28Y79	2	Cylinder, Hydraulic (Screed Lift)
8	28N77	1	Valve, Relief
9	27V85	2	Cylinder, Hydraulic (Hopper) (See Section 12 For Breakdown)
10	26K62	4	5/16" x 2.50" Hex Head Cap Screw
11	29K86	1	Valve (Hopper)
	10A06	1	Trim, Plastic x 2'-0" (Guilckedge)
13	12Z35	1	Elbow, 45° - 3/4" T. x 7/8"-14 Str. Thd.
14	29H25	1	Cooler, Oil
15	15W48	1	Kit, Cooler Mounting
16	ED-876-5283	2	Strap, Spacer
17	A1-80-556W	1	Manifold, Hydraulic
18	13J54	2	1/4" Lock Nut
19	A-876-5292W	2	Pin, Hopper Cylinder
20	26B08	2	3/8" x 3/4" Socket Head Set Screw
21	16W35	1	Filter (Return) (Consisting in part of the following indented item):
	16X52	1	• Element, Filter
22	16W34	2	Filter (Charge) (Consisting in part of the following indented item):
	16X52	1	• Element, Filter
23	27L99	4	#10 Lock Washer
24	A1-80-567W	1	Manifold (Return)
25	a 27Y30	1	Motor, Hydraulic (Propel)
26	27Y33	1	Fitting, Orifice
27	27Y29	1	Steering Unit
28	28J08	4	#10-24 x 2" Socket Head Cap Screw
29	27Y31	1	Valve, Shift
30	27Y32	1	Subplate
31	A-46-220/	1	1"-8 x 2-1/2" Ferry Head Cap Screw (Drilled Head)
32	27X16	1	Valve, Solenoid (See Section 12 For Breakdown)
33	F-17478	1	1-1/32" I.D. x 2" O.D. x 1/4" Thick Washer
34	29M35	1	Cylinder, Hydraulic (Steering) (See Section 12 For Breakdown)

REF.	PART NUMBER	QTY.	DESCRIPTION
35	29K31	1	Kit, Valve Assembly
36	B-876-5483	1	Plate, Valve Mounting
37	26B80	6	#10-24 x 1/2" Self Tapping Screw
38	29M32	1	Breather (Filter)
39	31L98	1	Strainer, Suction
40	10P30	1	Gauge, Level
41	27D20	2	1/2"-20 Nut
42	LB-876-5592W	2	Pin, Cylinder
43	16W28	1	Diffuser
45	C-80-85	1	Elbow, 1-1/4"
46	D1-80-80	1	Nipple, 1-1/4" x 3-1/2"
47	K-17-F25	1	Nipple, 1-1/4" x 9"
48	AC-876-5483	1	Cover, Access
49	F-876-3108	1	Gasket
50	26E25	26	5/16" x 3/4" Hex Head Cap Screw
51	26E54	14	5/16" Washer (Sealing)
52	14C38	2	Elbow, 90° - 1-1/4" T. x 1-1/4" Male N.P.T.F.
53	AI-876-5482W	1	Tank, Hydraulic
54	20M52	1	Sensor, Temperature
55	14L07	5	Elbow, 90° - 3/8" T. x 3/4"-16 Thd., O-Ring
56	23A81	1	Plug, 1" N.P.T. Pipe
57	12L57	1	Plug, 1/8" N.P.T. Pipe
58	23R60	2	Tee, 1/2" T. x 1/2" T. x 3/4"-16 Thd. O-Ring
	10C56	1	Oil, Hydraulic (45.2 Gallons)
60	23W72	3	Connector, 1/2" Tube x 9/16"-18 Thd.
61	12T24	2	Cap, 3/8" Tube
62	12T60	3	Cap, 1/2" Tube
63	23G64	2	Cap, 3/4" Tube
64	12X17	4	Bulkhead, 3/8" Tube x 3/8" Tube
65	16L59	1	Elbow, 1-1/4" St.
66	12X40	2	Tee, 3/8" Sq. Tube x 3/8" Tube
67	11K44	1	Tee, 3/8" Sq. Tee x 1/4" N.P.T.F.
68	23A06	1	Connector, 3/8" Tube x 1/4" N.P.T.F.
69	13D39	1	Elbow, 90°, 1-1/4" Tube x 1-5/8"-32 Str.
70	23P62	4	Connector, 3/8" Tube x 3/8" N.P.T.F.
71	23L84	1	Elbow, 90° - 1/4" T. x 1/8" N.P.T.F.
72	B-80-565W	1	Hose, 1/4" I.D. x 35"
73	27Y59	1	Connector, 1/4" T. x 1/8" N.P.T.F.
74	23K83	1	Connector, 3/4" Tube x 7/8"-14 Thd., O-Ring
75	13D39	2	Elbow, 90°, 1-1/4" T. x 1-5/8"-12 Str. Thd., O-Ring
76	23C20	3	Elbow, 90°, 3/8" Tube x 1/4" N.P.T.F.
77	23F29	1	Elbow, 90°, 3/4" Tube x 3/4" N.P.T.F.
78	23K04	3	Elbow, 90°, 1" Tube x 1" N.P.T.F.
79	26J03	2	Elbow, 90° - 3/8" T. x 3/8" J.I.C., Swivel
80	28G03	1	Elbow, 90°, 1-1/4" Tube x 1-1/2" N.P.T.F.
81	23F82	4	Elbow, 90°, 1/4" Tube x 7/16"-20 Thd., O-Ring
82	23P61	8	Elbow, 90°, 3/8" Tube x 9/16"-18 Thd., O-Ring
83	15J71	1	Elbow, 45° - 3/8" T. x 9/16"-18 Thd., O-Ring
84	23R13	1	Elbow, 90°, 1/2" Tube x 7/8"-14 Thd., O-Ring
85	28G04	4	Elbow, 90°, 3/4" Tube x 3/4"-16 Thd., O-Ring

5/1/90 (1-22) (2-17)

(Continued)

REF.	PART NUMBER	QTY.	DESCRIPTION
86	13G10	2	Elbow, 90°, 3/4" Tube x 7/8"-14 Thd.,- O-Ring
87	23J55	6	Elbow, 90°, 1" Tube x 1-15/16"-12 Thd.,- O-Ring
88	15B96	1	Tee, 3/8" Sq. Tube x 1/4" N.P.T.F.
89	23R41	2	Elbow, 90°, 3/8" Tube x 1/2" N.P.T.F.
90	13M64	1	Elbow, 45°, 1" Tube x 1" N.P.T.F.
91	15J70	1	Elbow, 45°, 3/4" Tube x 1-1/16"-12 Thd.,- O-Ring
92	23J56	2	Elbow, 45°, 1" Tube x 1-5/16"-12 Thd.,- O-Ring
93	14T33	1	Elbow, 90°, 1-1/4" Tube x 1-1/4" J.I.C. Swivel
94	13J69	1	Tee, 1/2" Sq. Tube x 1/2" J.I.C. Swivel
95	26J04	2	Elbow, 90°, 3/4" Tube x 3/4" J.I.C. Swivel
96	14T34	2	Elbow, 90°, 1" Tube x 1" J.I.C. Swivel
97	12X09	2	Bulkhead, 3/4" Tube x 3/4" Tube
98	27R41	4	Elbow, 90°, 1" Tube x 1" Flange
99	14Y57	1	Tee, 1" Tube x 1" Tube x 1" Tube
100	12W74	2	Tee, Bulkhead, 3/8" Tube x 3/8" Tube 3/8" Tube
101	13K98	2	Elbow, 90°, 3/8" Tube x 1/2" Male N.P.T.F. x 1/16" Orifice
102	23H54	1	Connector, 1/2" T. x 3/4"-16 Str. Thd.
103	18D99	3	Bushing, Reducing, 1" x 1-1/4"
104	23R36	1	Bushing, Reducing, 3/4" x 1-1/4"
105	28W79	4	O-Ring
106	29C06	1	Elbow, 90°, 1/4" Swivel x 7/16"-20 Str. O-Ring
107	10E09	8	Flange, 1" Split
108	27C86	2	1/4" Hex Nut
109	27L77	12	5/16" Lock Washer
110	23H55	1	Plug, 3/16"-16 Str. Thd., O-Ring
111	26C53	2	3/8" x 1" Hex Head Cap Screw
112	27L78	6	3/8" Lock Washer
113	16W90	4	1/4" x 2" Hex Head Cap Screw
114	13J31	5	1/4" x 3/4" Hex Head Cap Screw
115	27L76	15	1/4" Lock Washer
116	27L52	6	1/4" Cut Washer
117	27C90	2	3/8" Hex Nut
118	AD-80-509W	1	Hose, 1" I.D. x 35"
119	AB-80-513W	1	Hose, 1-1/4" I.D. x 35"
120	D-80-571W	1	Hose, 1-1/4" I.D. x 63"
121	D-80-516W	1	Hose, 3/4" I.D. x 33"
122	B-80-571W	1	Hose, 1-1/4" I.D. x 33"
123	AY-80-485W	1	Hose, 1" I.D. x 96"
124	BV-80-485W	1	Hose, 1" I.D. x 68"
125	BC-80-485W	1	Hose, 1" I.D. x 89"
126	AZ-80-485W	2	Hose, 1" I.D. x 63"
127	AL-80-478W	1	Hose, 1" I.D. x 57"
128	DL-80-482W	1	Hose, 3/8" I.D. x 43"
129	Y-80-510W	1	Hose, 1" I.D. x 37"
130	G-80-512W	1	Hose, 1" I.D. x 25"
131	AG-80-516W	1	Hose, 3/4" I.D. x 98"
132	AZ-80-479W	1	Hose, 3/4" I.D. x 76"
133	Y-80-516W	1	Hose, 3/4" I.D. x 20"
134	AJ-80-516W	1	Hose, 3/4" I.D. x 30"

REF.	PART NUMBER	QTY.	DESCRIPTION
135	H-80-512W	1	Hose, 1" I.D. x 41"
136	K-80-491W	2	Hose, 3/8" I.D. x 34"
137	AV-80-480W	1	Hose, 3/4" I.D. x 91"
138	N-80-479W	1	Hose, 3/4" I.D. x 34"
139	A-80-592W	1	Hose, 1-1/4" I.D. x 69"
140	D-80-491W	2	Hose, 3/8" I.D. x 46"
141	23M23	2	Plug, 1-5/8" St. Thd., O-Ring
143	23P99	1	Elbow, 90° - 1/2" T. x 3/4"-16 Str. Thd.
144	BZ-80-491W	1	Hose, 3/8" I.D. x 41"
145	23Y11	2	1/4" x .89" Hex Head Cap Screw
146	15C75	1	Plug, 1-3/16"-12 Str. Thd. w/ O-Ring
147	23C66	2	Fitting, 1/8" N.P.T.F. x 90°
148	23C60	2	Fitting, 1/8" N.P.T.F., Str.
149	BT-80-491W	1	Hose, 3/8" I.D. x 104"
150	10E10	16	3/8" x 1-1/4" Hex Head Cap Screw
151	27L78	16	3/8" Lock Washer
201	X-80-482W	2	Hose, 3/8" I.D. x 80"
202	BK-80-491W	1	Hose, 3/8" I.D. x 71"
203	L-80-482W	1	Hose, 3/8" I.D. x 29"
204	L-80-479W	1	Hose, 3/4" I.D. x 30"
206	AS-80-491W	2	Hose, 3/8" I.D. x 51" (For Auto Grade Control)
207	R-80-482W	4	Hose, 3/8" I.D. x 48"
208	BZ-80-482W	2	Hose, 3/8" I.D. x 71"
	11P81	30	Tie, Plastic Wire
	10B23	15	Tie, Plastic Wire
211	BW-80-491W	1	Hose, 3/8" I.D. x 39"
212	BY-80-491W	1	Hose, 3/8" I.D. x 66"
213	DH-80-491W	2	Hose, 3/8" I.D. x 18"
214	23F70	2	Nut, 1/2" T.
215	26J12	1	Reducer, 1/2" T. x 3/8" T.
216	23H41	2	Elbow, 90° - 3/4" T. x 1-1/16"-12 Thd., O-Ring
217	ES-80-484W	1	Hose, 1/4" I.D. x 37"
218	ET-80-484W	1	Hose, 1/4" I.D. x 17"
219	AN-80-490W	1	Hose, 1/4" I.D. x 77"
220	AP-80-490W	1	Hose, 1/4" I.D. x 48"
221	N-80-508W	1	Hose, 3/4" I.D. x 78"
222	J-876-4628	2	Spacer, 3/8" Belling
223	27L58	6	1/2" Cut Washer
224	AR-80-490W	1	Hose, 1/4" I.D. x 33"
225	L-80-508W	1	Hose, 3/4" I.D. x 68"
226	EV-80-484W	2	Hose, 1/4" I.D. x 42"
227	11V33	1	Connector, 1" T. x 1-5/8"-12 Thd., O-Ring
228	16R42	2	U-Bolt
229	27Y42	1	Elbow, 45° - 3/4" T. x 3/4" J.I.C., Swivel
230	20K38	1	Clamp
231	23R04	1	Connector, 3/8" O.D. x 3/4"-16 Male S.A.E. Thd.
232	27C95	3	1/2" Hex Nut
233	23N59	1	Connector, 1" Tube x 1" N.P.T.F.
234	12127	1	Plug, 1" Tube
235	D-80-509W	1	Hose, 1" I.D. x 37"

REF.	PART NUMBER	QTY.	DESCRIPTION
236	DA-876-5283	2	Pin, 3/4" Dia. x 4-1/2"
237	26C53	4	3/8" x 1" Hex Head Cap Screw
238	BU-17-25	2	Pin, 1" Dia. x 3.88"
239	DA-876-5283	2	Bar
240	12T11	2	1/2" x 1-3/4" Flat Head Cap Screw
241	27D64	4	Pin, Cotter - 3/16" x 1-1/2"
242	B-53-1794	2	Gasket
243	13J37	15	1/2" x 1-3/4" Hex Head Cap Screw
244	C-17-478	12	Washer, 17/32" I.D. x 1" O.D. x 1/4" Thick
245	A-53-2517	4	Gasket
246	26E29	2	1/2" x 1-1/2" Hex Head Cap Screw
247	27L81	19	1/2" Lock Washer
248	26J11	1	Reducer, 1/2" T. x 1/4" T.
249	27Y53	1	Tee, 1/4" T. x 1/4" T. x 7/16"-20
250	29J32	4	Nipple, Tube End
251	29F42	4	Plug, Dust
252	29E60	2	Gauge, Vacuum
253	29M31	1	Elbow, 45° - St. x 1/4" N.P.T.F.
254	28M75	1	Coupling, 1/4" N.P.T.F.
255	23N77	1	Nipple, 1/4" N.P.T.F.
256	23R14	2	Tee, 1" T. x 1" T. x 1-5/16-12 Swivel
257	29M91	2	Connector, Reducer (With .050" Orifice)
258	E-80-196W	1	Hose, 3/8" I.D. x 59.00"
259	K-80-197W	1	Hose, 3/8" I.D. x 52.00"

o - Consult Barber-Greene Repair Parts Department for repairs on this item.

TRACTOR HYDRAULICS
(Hydraulic Tank Assembly)
(Illustration 1 of 2)

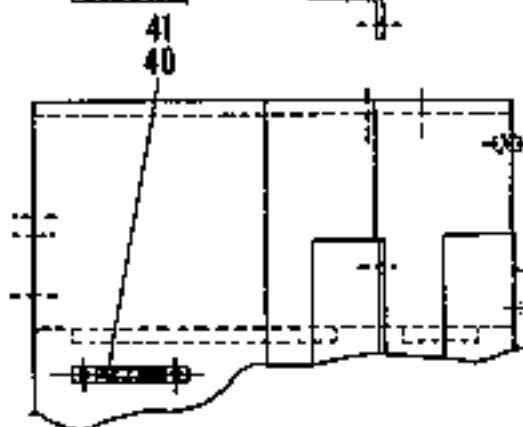
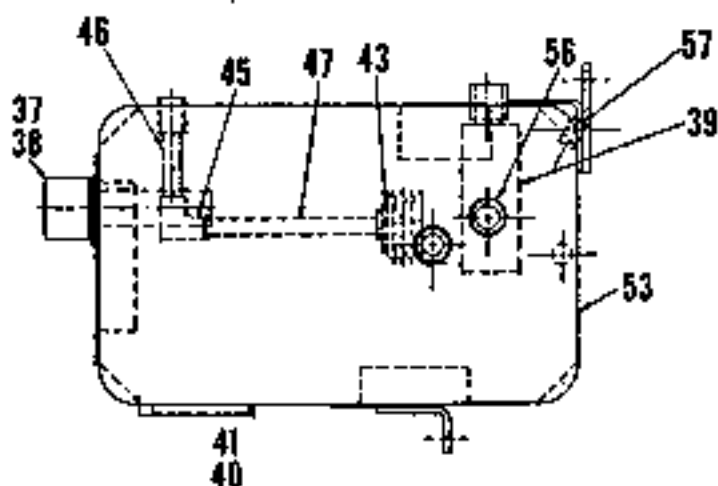
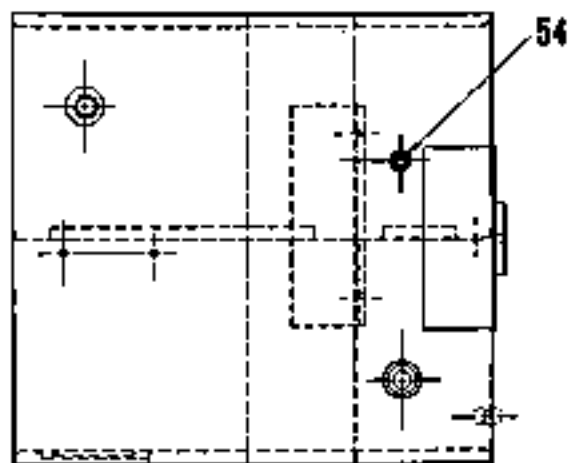
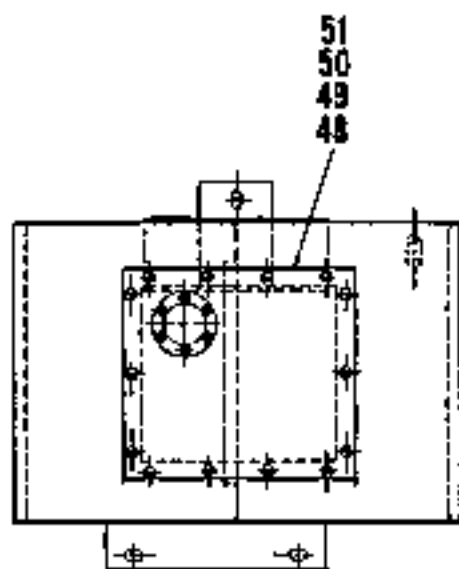

Key to
 Reference Number Symbols

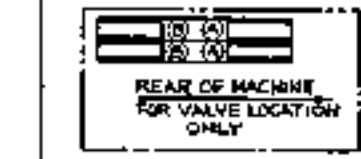
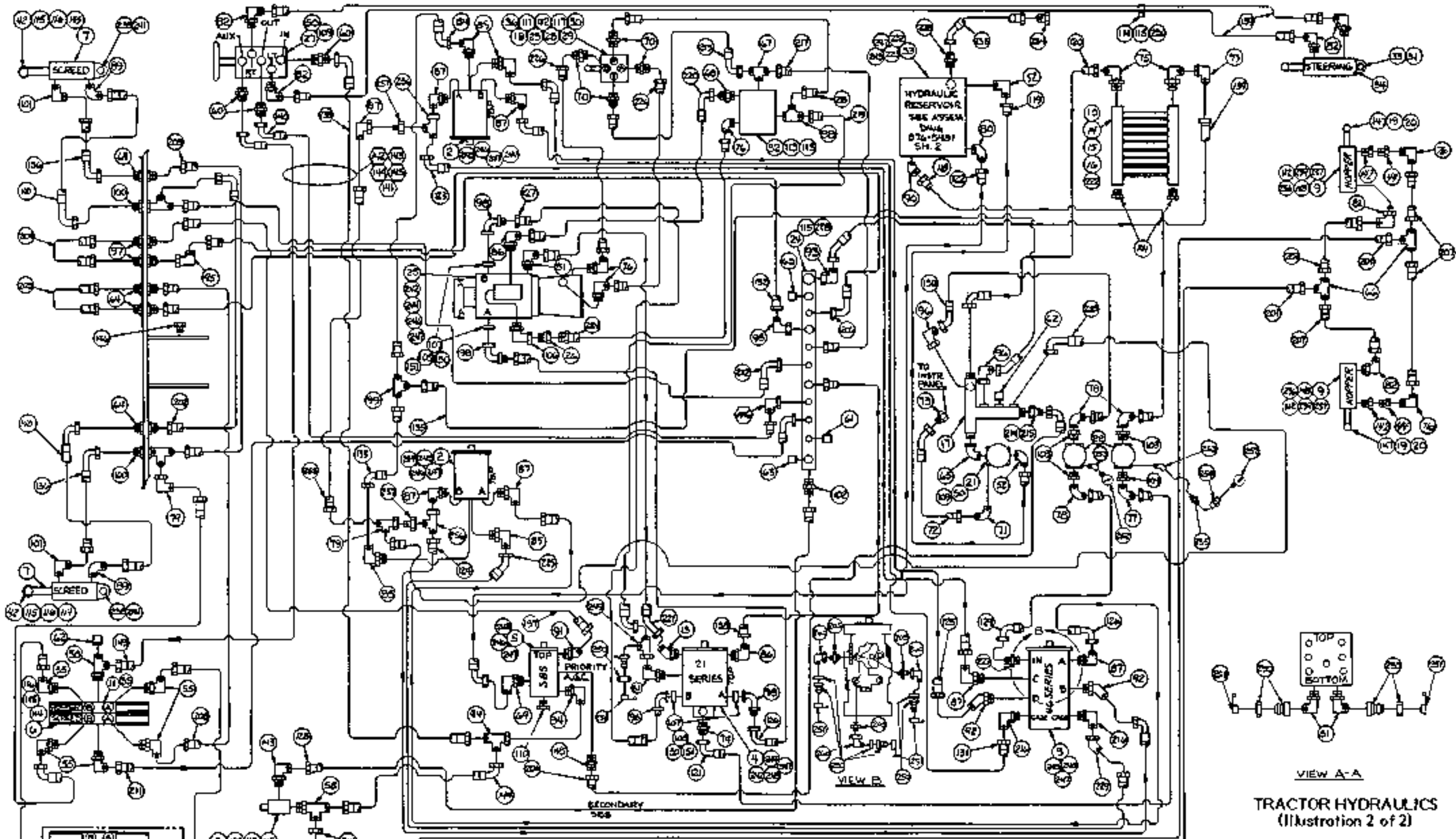

SYMBOL	B/M
--------	-----

NONE - A10-876-548DB (Tractor Hydraulics)



Key to
Reference Number Symbols

SYMBOL	B/M
--------	-----

-  = A10-876-5490R (Tractor Hydraulics) 8/20/91 (1-21)
-  = D2-876-5480R (Single Control Station)

TRACTOR HYDRAULICS
(Illustration 2 of 2)

TRACTOR HYDRAULICS

A10-876-5480B

(Before Ordering, Consult Table of Contents to Verify Proper Bill of Material Number.)

REF.	PART NUMBER	QTY.	DESCRIPTION
Ref. #2 thru #260 Symbolized by NONE on Illustration 1 and			
Also Symbolized by  on Illustration 2.			
2	28N95	2	Motor, Hydraulic (Feeder & Screw) (See Section 12 For Breakdown)
3	28W80	1	Pump, Hydraulic (Feeder & Screw Tandem)
4	29N52	1	Pump, Hydraulic (Propel)
5	29P51	1	Pump, Hydraulic (SBS) (Screed Lift, Hopper Cylinders & Steering)
6	29R30	1	Valve (Screed)
7	28Y79	2	Cylinder, Hydraulic (Screed Lift)
8	28N77	1	Valve, Relief
9	27V85	2	Cylinder, Hydraulic (Hopper) (See Section 12 For Breakdown)
10	26K62	4	5/16" x 2.50" Hex Head Cap Screw
11	29R86	1	Valve (Hopper)
	10A06	1	Trim, Plastic x 2'-0" (Quickedge)
13	12Z35	1	Elbow, 45° - 3/4" T. x 7/8"-14 Str. Thd.
14	29H25	1	Cooler, Oil
15	15W48	1	Kit, Cooler Mounting
16	BD-876-5283	2	Strap, Spacer
17	AI-80-556W	1	Manifold, Hydraulic
18	13J54	2	1/4" Lock Nut
19	CB-876-5282W	2	Pin, Hopper Cylinder
20	26F45	2	3/8" x 3/4" Flat Head Set Screw
21	16W35	1	Filter (Return) (Consisting in part of the following indented item):
	16X52	1	. Element, Filter
22	16W34	2	Filter (Charge) (Consisting in part of the following indented item):
	16X52	1	. Element, Filter
23	27L99	4	#10 Lock Washer
24	AI-80-567W	1	Manifold (Return)
25	27Y30	1	Motor, Hydraulic (Propel)
26	27Y33	1	Fitting, Orifice
27	27Y29	1	Steering Unit
28	32A64	4	#10-24 x 1.25" Socket Head Cap Screw
29	27Y31	1	Valve, Shift
30	27Y32	1	Subplate
31	A-46-2207	1	1"-8 x 2-1/2" Ferry Head Cap Screw (Drilled Head)
32	27X16	1	Valve, Solenoid (See Section 12 For Breakdown)
33	F-17-478	1	1-1/32" I.D. x 2" O.D. x 1/4" Thick Washer
34	28M35	1	Cylinder, Hydraulic (Steering) (See Section 12 For Breakdown)

REF.	PART NUMBER	QTY.	DESCRIPTION
35	29R31	1	Kit, Valve Assembly
36	B-876-5483	1	Plate, Valve Mounting
37	26B80	6	#10-24 x 1/2" Self Tapping Screw
38	29M32	1	Breather (Filter)
39	31L98	1	Strainer, Suction
40	10P30	1	Gauge, Level
41	27D20	2	1/2"-20 Nut
42	LB-876-5592W	2	Pin, Cylinder
43	16W2B	1	Diffuser
44	29T26	2	Restrictor, 3/64" Orifice
45	G-80-85	1	Elbow, 1-1/4"
46	DT-80-80	1	Nipple, 1-1/4" x 3-1/2"
47	K-17-125	1	Nipple, 1-1/4" x 9"
48	AC-876-5483	1	Cover, Access
49	F-876-3108	1	Gasket
50	26E25	26	5/16" x 3/4" Hex Head Cap Screw
51	26E54	14	5/16" Washer (Sealing)
52	14C38	2	Elbow, 90° - 1-1/4" T. x 1-1/4" Male N.P.T.F.
53	AI-876-5482W	1	Tank, Hydraulic
54	20M52	1	Sensor, Temperature
55	14L07	5	Elbow, 90° - 3/8" T. x 3/4"-16 Thd., O-Ring
56	23A91	1	Plug, 1" N.P.T. Pipe
57	12L57	1	Plug, 1/8" N.P.T. Pipe
58	23P60	2	Tee, 1/2" T. x 1/2" T. x 3/4"-16 Thd. O-Ring
	10C56	1	Oil, Hydraulic (45.2 Gallons)
60	23W72	3	Connector, 1/2" Tube x 9/16"-18 Thd.
61	12T24	2	Cap, 3/8" Tube
62	12T60	3	Cap, 1/2" Tube
63	23C64	2	Cap, 3/4" Tube
64	12X17	4	Subhead, 3/8" Tube x 3/8" Tube
65	16L59	1	Elbow, 1-1/4" St.
66	12X40	2	Tee, 3/8" Sq. Tube x 3/8" Tube
67	11K44	1	Tee, 3/8" Sq. Tee x 1/4" N.P.T.F.
68	23A06	1	Connector, 3/8" Tube x 1/4" N.P.T.F.
69	13D39	1	Elbow, 90°, 1-1/4" Tube x 1-5/8"-12 Str.
70	23P62	4	Connector, 3/8" Tube x 3/8" N.P.T.F.
71	23L84	1	Elbow, 90° - 1/4" T. x 1/8" N.P.T.F.
72	29T49	1	Hose, 1/4" I.D. x 39"
73	27Y59	1	Connector, 1/4" T. x 1/8" N.P.T.F.
74	23K83	1	Connector, 3/4" Tube x 7/8"-14 Thd., O-Ring
75	13D39	2	Elbow, 90°, 1-1/4" T. x 1-5/8"-12 Str. Thd., O-Ring
76	23C20	5	Elbow, 90°, 3/8" Tube x 1/4" N.P.T.F.
77	23F29	1	Elbow, 90°, 3/4" Tube x 3/4" N.P.T.F.
78	23K04	3	Elbow, 90°, 1" Tube x 1" N.P.T.F.
79	26J03	2	Elbow, 90° - 3/8" T. x 3/8" J.I.C., Swivel
80	28C03	1	Elbow, 90°, 1-1/4" Tube x 1-1/2" N.P.T.F.
81	23N82	4	Elbow, 90°, 1/4" Tube x 7/16"-20 Thd., O-Ring
82	23P61	6	Elbow, 90°, 3/8" Tube x 9/16"-18 Thd., O-Ring
83	15J71	1	Elbow, 45° - 3/8" T. x 9/16"-18 Thd., O-Ring
84	23R13	1	Elbow, 90°, 1/2" Tube x 7/8"-14 Thd., O-Ring

REF.	PART NUMBER	QTY.	DESCRIPTION
85	28G04	4	Elbow, 90°, 3/4" Tube x 3/4"-16 Thd.,- O-Ring
86	13G10	2	Elbow, 90°, 3/4" Tube x 7/8"-14 Thd.,- O-Ring
87	23J55	6	Elbow, 90°, 1" Tube x 1-5/16"-12 Thd.,- O-Ring
88	15B96	1	Tee, 3/8" Sq. Tube x 1/4" N.P.T.F.
89	23R41	2	Elbow, 90°, 3/8" Tube x 1/2" N.P.T.F.
90	13M64	1	Elbow, 45°, 1" Tube x 1" N.P.T.F.
91	15J70	1	Elbow, 45°, 3/4" Tube x 1-1/16"-12 Thd.,- O-Ring
92	23J56	2	Elbow, 45°, 1" Tube x 1-5/16"-12 Thd.,- O-Ring
93	14T33	2	Elbow, 90°, 1-1/4" Tube x 1-1/4" J.I.C. Swivel
94	13J69	1	Tee, 1/2" Sq. Tube x 1/2" J.I.C. Swivel
95	26J04	2	Elbow, 90°, 3/4" Tube x 3/4" J.I.C. Swivel
96	14T34	2	Elbow, 90°, 1" Tube x 1" J.I.C. Swivel
97	12X09	2	Bulkhead, 3/4" Tube x 3/4" Tube
98	27R41	4	Elbow, 90°, 1" Tube x 1" Flange
99	14Y57	1	Tee, 1" Tube x 1" Tube x 1" Tube
100	12W74	2	Tee, Bulkhead, 3/8" Tube x 3/8" Tube 3/8" Tube
101	13K98	2	Elbow, 90°, 3/8" Tube x 1/2" Male N.P.T.F. x 1/16" Orifice
102	23H54	1	Connector, 1/2" T. x 3/4"-16 Str. Thd.
103	10D99	3	Bushing, Reducing, 1" x 1-1/4"
104	23R36	1	Bushing, Reducing, 3/4" x 1-1/4"
105	28W79	4	O-Ring
106	28G06	1	Elbow, 90°, 1/4" Swivel x 7/16"-20 Str. O-Ring
107	10E09	8	Flange, 1" Split
108	27C86	2	1/4" Hex Nut
109	27L77	12	5/16" Lock Washer
110	23H55	1	Plug, 3/4"-16 Str. Thd., O-Ring
111	26C53	2	3/8" x 1" Hex Head Cap Screw
112	27L78	6	3/8" Lock Washer
113	16W90	4	1/4" x 2" Hex Head Cap Screw
114	13J31	5	1/4" x 3/4" Hex Head Cap Screw
115	27L76	15	1/4" Lock Washer
116	27L52	6	1/4" Cut Washer
117	27C90	2	3/8" Hex Nut
118	AD-80-509W	1	Hose, 1" I.D. x 35"
119	AB-80-513W	1	Hose, 1-1/4" I.D. x 35"
120	D-80-571W	1	Hose, 1-1/4" I.D. x 63"
121	D-80-516W	1	Hose, 3/4" I.D. x 33"
122	B-80-571W	1	Hose, 1-1/4" I.D. x 33"
123	AY-80-485W	1	Hose, 1" I.D. x 96"
124	BV-80-485W	1	Hose, 1" I.D. x 68"
125	BC-80-485W	1	Hose, 1" I.D. x 89"
126	AZ-80-485W	2	Hose, 1" I.D. x 63"
127	AL-80-478W	1	Hose, 1" I.D. x 57"
128	DL-80-482W	1	Hose, 3/8" I.D. x 43"
129	Y-80-510W	1	Hose, 1" I.D. x 37"
130	G-80-512W	1	Hose, 1" I.D. x 25"
131	AG-80-516W	1	Hose, 3/4" I.D. x 98"
132	AZ-80-479W	1	Hose, 3/4" I.D. x 76"
133	Y-80-516W	1	Hose, 3/4" I.D. x 20"
134	AJ-80-516W	1	Hose, 3/4" I.D. x 30"

REF.	PART NUMBER	QTY.	DESCRIPTION
135	H-80-512W	1	Hose, 1" I.D. x 41"
136	R-80-491W	2	Hose, 3/8" I.D. x 34"
137	AV-80-480W	1	Hose, 3/4" I.D. x 91"
138	N-80-479W	1	Hose, 3/4" I.D. x 34"
139	A-80-592W	1	Hose, 1-1/4" I.D. x 68"
140	D-80-491W	2	Hose, 3/8" I.D. x 46"
141	23M23	2	Plug, 1-5/8" St. Thd., O-Ring
142	23M76	2	Connector, 1/4" N.P.T.F x 9/16"-18, O-Ring
143	23P99	1	Elbow, 90° - 1/2" T. x 3/4"-16 Str. Thd.
144	BZ-80-491W	1	Hose, 3/8" I.D. x 41"
145	23Y11	2	1/4" x .88" Hex Head Cap Screw
146	15C75	1	Plug, 1-3/16"-12 Str. Thd. w/ O-Ring
147	23C66	2	Fitting, 1/8" N.P.T.F. x 90°
148	23C60	2	Fitting, 1/8" N.P.T.F., Str.
149	BT-80-491W	1	Hose, 3/8" I.D. x 104"
150	10E10	16	3/8" x 1-1/4" Hex Head Cap Screw
151	27L78	16	3/8" Lock Washer
201	X-80-482W	2	Hose, 3/8" I.D. x 80"
202	BK-80-491W	1	Hose, 3/8" I.D. x 71"
203	L-80-482W	1	Hose, 3/8" I.D. x 79"
204	L-80-479W	1	Hose, 3/4" I.D. x 30"
205	28K68	3	Connector, 1/4" T. x 9/16"-18 Str. Thd., O-Ring
206	AS-80-491W	2	Hose, 3/8" I.D. x 51" (For Auto Grade Control)
207	R-80-482W	4	Hose, 3/8" I.D. x 48"
208	BZ-80-482W	2	Hose, 3/8" I.D. x 71"
	11P81	30	Tie, Plastic Wire
	10823	15	Tie, Plastic Wire
211	BW-80-491W	1	Hose, 3/8" I.D. x 39"
212	BY-80-491W	1	Hose, 3/8" I.D. x 66"
213	DH-80-491W	2	Hose, 3/8" I.D. x 18"
214	23F70	2	Nut, 1/2" T.
215	26J12	1	Reducer, 1/2" T. x 3/8" T.
216	23F41	2	Elbow, 90° - 3/4" T. x 1-1/16"-12 Thd., O-Ring
217	ES-80-484W	1	Hose, 1/4" I.D. x 37"
218	ET-80-484W	1	Hose, 1/4" I.D. x 17"
219	AN-80-490W	1	Hose, 1/4" I.D. x 77"
220	AP-80-490W	1	Hose, 1/4" I.D. x 48"
221	N-80-508W	1	Hose, 3/4" I.D. x 78"
222	J-876-4628	2	Spacer, 3/8" Betting
223	27L58	6	1/2" Cut Washer
224	AR-80-490W	1	Hose, 1/4" I.D. x 33"
225	L-80-508W	1	Hose, 3/4" I.D. x 68"
226	EV-80-484W	2	Hose, 1/4" I.D. x 42"
227	11V33	1	Connector, 1" T. x 1-5/8"-12 Thd., O-Ring
228	16R42	2	U-Bolt
229	27Y42	1	Elbow, 45° - 3/4" T. x 3/4" J.I.C., Swivel
230	20K38	1	Clamp
231	23R04	1	Connector, 3/8" O.D. x 3/4"-16 Male S.A.E. Thd.
232	27C95	3	1/2" Hex Nut
233	23N59	1	Connector, 1" Tube x 1" N.P.T.F.

REF.	PART NUMBER	QTY.	DESCRIPTION
234	12T27	1	Plug, 1" Tube
235	D-80-509W	1	Hose, 1" I.D. x 37"
236	DA-876-5283	2	Pin, 3/4" Dia. x 4-1/2"
237	26C53	4	3/8" x 1" Hex Head Cap Screw
238	BU-17-25	2	Pin, 1" Dia. x 3.88"
239	DB-876-5283	2	Bar
240	12T11	2	1/2" x 1-3/4" Flat Head Cap Screw
241	27D64	4	Pin, Cotter - 3/16" x 1-1/2"
242	B-53-1794	2	Gasket
243	13J37	15	1/2" x 1-3/4" Hex Head Cap Screw
244	C-17-478	12	Washer, 17/32" I.D. x 1" O.D. x 1/4" Thick
245	A-53-2517	4	Gasket
246	26E29	2	1/2" x 1-1/2" Hex Head Cap Screw
247	27L81	19	1/2" Lock Washer
248	26J11	1	Reducer, 1/2" T. x 1/4" T.
249	27Y53	1	Tee, 1/4" T. x 1/4" T. x 7/16"-20
250	29J32	7	Nipple, Tube End
251	29F42	7	Plug, Dust
252	29E60	2	Gauge, Vacuum
253	29M31	2	Elbow, 45° - St. x 1/4" N.P.T.F.
254	28M75	1	Coupling, 1/4" N.P.T.F.
255	23N77	1	Nipple, 1/4" N.P.T.F.
256	23R14	2	Tee, 1" T. x 1" T. x 1-5/16"-12 Swivel
257	29M91	2	Connector, Reducer (With .050" Orifice)
258	E-80-496W	1	Hose, 3/8" I.D. x 58.00"
259	K-80-497W	1	Hose, 3/8" I.D. x 52.00"
260	27Y57	3	Elbow, 90° - 1/4" T. x 1/4" J.I.C. Swivel

a - Consult Barber-Greene Repair Parts Department for repairs on this item.

TRACTOR HYDRAULICS
(Hydraulic Tank Assembly)
(Illustration 1 of 2)

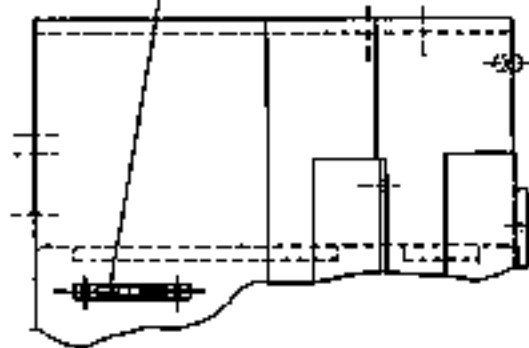
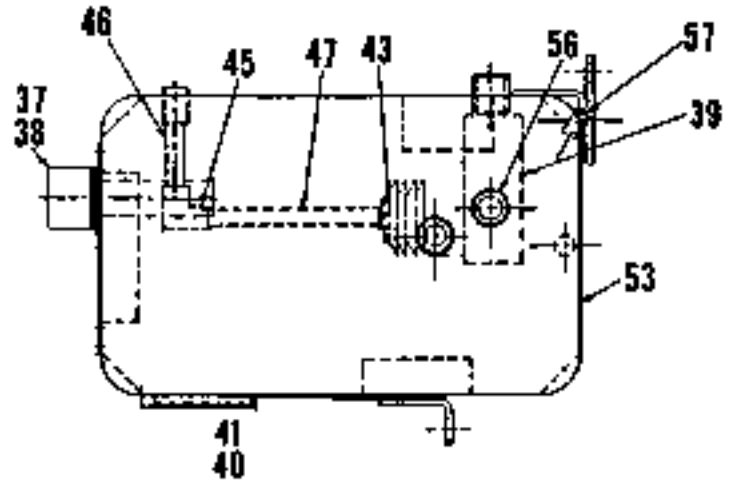
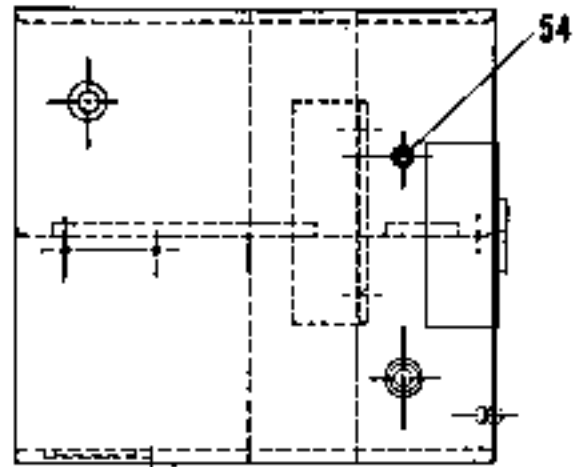
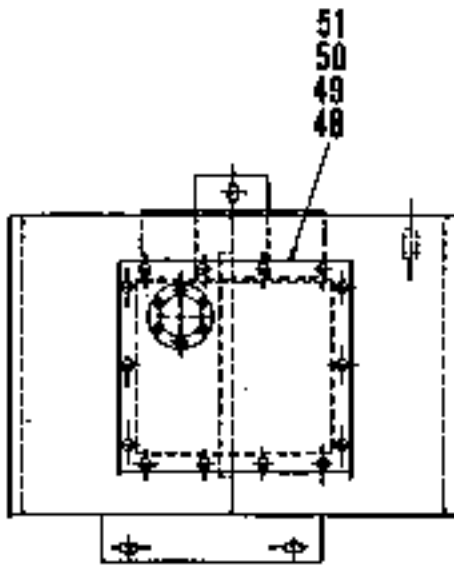

Key to
Reference Number Symbols

SYMBOL	B/M
--------	-----

NONE = A12-876-5480B (Tractor Hydraulics)

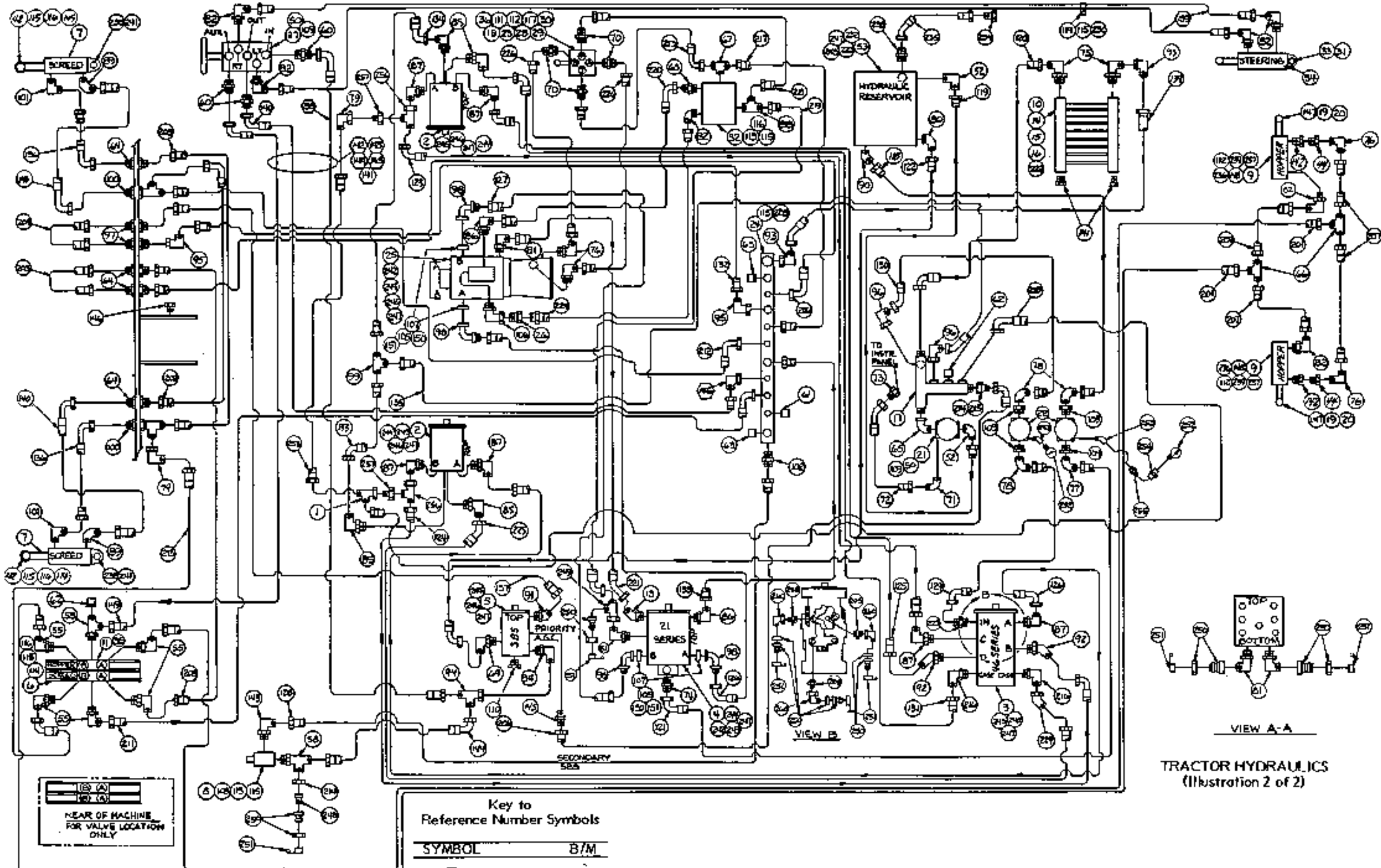

Key to Reference Number Symbols

SYMBOL	B/M
○	A17-876-5480B (Tractor Hydraulics) 12/12/91 (1-23)
◡	D2-876-5480B (Single Control Station)

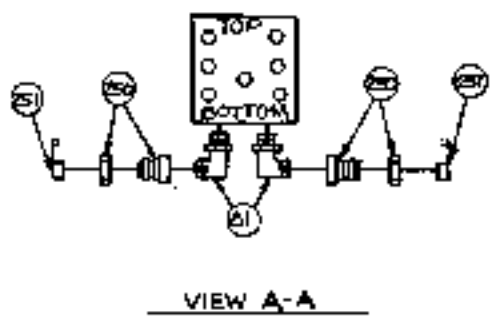

TRACTOR HYDRAULICS
(Illustration 2 of 2)

TRACTOR HYDRAULICS

A12-876-5480B

(Before Ordering, Consult Table of Contents to Verify Proper Bill of Material Number.)

REF.	PART NUMBER	QTY.	DESCRIPTION
Ref. #1 thru #260 Symbolized by NONE on Illustration 1 and			
Also Symbolized by  on Illustration 2.			
1	23T03	1	Tee, 3/8" T. x 3/8" T. x 3/8" Swivel
2	28N95	2	Motor, Hydraulic (Feeder & Screw) (See Section 12 For Breakdown)
3 a	29W80	1	Pump, Hydraulic (Feeder & Screw Tandem)
4 a	29N52	1	Pump, Hydraulic (Propel)
5 a	29P51	1	Pump, Hydraulic (SBS) (Screed Lift, Hopper Cylinders & Steering)
6 a	29R30	1	Valve (Screed)
7 a	28Y79	2	Cylinder, Hydraulic (Screed Lift)
8	28N77	1	Valve, Relief
9	27V85	2	Cylinder, Hydraulic (Hopper) (See Section 12 For Breakdown)
10	26X62	4	5/16" x 2.50" Hex Head Cap Screw
11	29R86	1	Valve (Hopper)
	10A06	1	Trim, Plastic x 2'-0" (Quickedge)
13	12Z35	1	Elbow, 45° - 3/4" T. x 7/8"-14 Str. Thd.
14	29I25	1	Cooler, Oil
15	15W48	1	Kit, Cooler Mounting
16	BD-876-5283	2	Strap, Spacer
17	A1-80-556W	1	Manifold, Hydraulic
18	13J54	2	1/4" Lock Nut
19	CB-876-5282W	2	Pin, Hopper Cylinder
20	26F45	2	3/8" x 3/4" Flat Head Set Screw
21	16W35	1	Filter (Return) (Consisting in part of the following indented item):
	16X52	1	. Element, Filter
22	16W34	2	Filter (Charge) (Consisting in part of the following indented item):
	16X52	1	. Element, Filter
23	27L99	4	#10 Lock Washer
24	A1-80-567W	1	Manifold (Return)
25 a	27Y30	1	Motor, Hydraulic (Propel)
26	27Y33	1	Fitting, Orifice
27	27Y29	1	Steering Unit
28	32A64	4	#10-24 x 1.25" Socket Head Cap Screw
29	27Y31	1	Valve, Shift
30	27Y32	1	Subplate
31	A-46-2207	1	1" x 2-1/2" Flange Head Cap Screw (Drilled Head)
32	32A76	1	Valve
33	F-17-478	1	1-1/32" I.D. x 2" O.D. x 1/4" Thick Washer

REF.	PART NUMBER	QTY.	DESCRIPTION
34	28M35	1	Cylinder, Hydraulic (Steering) (See Section 12 For Breakdown)
35	29R31	1	Kit, Valve Assembly
36	B-876-5483	1	Plate, Valve Mounting
37	26B80	6	#10-24 x 1/2" Self Tapping Screw
38	29M32	1	Breather (Filler)
39	31L98	1	Strainer, Suction
40	10P30	1	Gauge, Level
41	27D20	2	1/2"-20 Nut
42	LB-876-5592W	2	Pin, Cylinder
43	16W28	1	Diffuser
44	29T26	2	Restrictor, 3/64" Orifice
45	G-80-85	1	Elbow, 1-1/4"
46	DT-80-80	1	Nipple, 1-1/4" x 3-1/2"
47	K-17-125	1	Nipple, 1-1/4" x 9"
48	AC-876-5483	1	Cover, Access
49	F-876-3108	1	Gasket
50	26E25	26	5/16" x 3/4" Hex Head Cap Screw
51	26E54	14	5/16" Washer (Sealing)
52	14C38	2	Elbow, 90° - 1-1/4" T. x 1-1/4" Male N.P.T.F.
53	AI-876-5482W	1	Tank, Hydraulic
54	32A56	1	Sensor, Temperature
55	14L07	5	Elbow, 90° - 3/8" T. x 3/4"-16 Thd., O-Ring
56	23A81	1	Plug, 1" N.P.T. Pipe
57	12L57	1	Plug, 1/8" N.P.T. Pipe
58	23R60	2	Tee, 1/2" T. x 1/2" T. x 3/4"-16 Thd. O-Ring
	10C56	1	Oil, Hydraulic (45.2 Gallons)
60	23W72	3	Connector, 1/2" Tube x 9/16"-18 Thd.
61	12T24	2	Cap, 3/8" Tube
62	12T60	3	Cap, 1/2" Tube
63	23G64	2	Cap, 3/4" Tube
64	12X17	4	Bulkhead, 3/8" Tube x 3/8" Tube
65	16L59	1	Elbow, 1-1/4" St.
66	12X40	2	Tee, 3/8" Sq. Tube x 3/8" Tube
67	13X21	1	Tee, 3/8" T. x 9/16"-18, W/ O-Ring x 3/8" T.
68	23R05	1	Connector, 3/8" T. x 9/16"-18, W/ O-Ring
69	13D39	1	Elbow, 90°, 1-1/4" Tube x 1-5/8"-12 Str.
70	23P62	4	Connector, 3/8" Tube x 3/8" N.P.T.F.
71	23L84	1	Elbow, 90° - 1/4" T. x 1/8" N.P.T.F.
72	29T49	1	Hose, 1/4" I.D. x 39"
73	27Y59	1	Connector, 1/4" T. x 1/8" N.P.T.F.
74	23K83	1	Connector, 3/4" Tube x 7/8"-14 Thd.,- O-Ring
75	13D39	2	Elbow, 90°, 1-1/4" T. x 1-5/8"-12 Str. Thd., O-Ring
76	23C20	4	Elbow, 90°, 3/8" Tube x 1/4" N.P.T.F.
77	23F29	1	Elbow, 90°, 3/4" Tube x 3/4" N.P.T.F.
78	23K04	3	Elbow, 90°, 1" Tube x 1" N.P.T.F.
79	26J03	2	Elbow, 90° - 3/8" T. x 3/8" J.I.C., Swivel
80	28G03	1	Elbow, 90°, 1-1/4" Tube x 1-1/2" N.P.T.F.
81	23N82	4	Elbow, 90°, 1/4" Tube x 7/16"-20 Thd.,- O-Ring
82	23P61	7	Elbow, 90°, 3/8" Tube x 9/16"-18 Thd.,- O-Ring

REF.	PART NUMBER	QTY.	DESCRIPTION
83	15J71	1	Elbow, 45° - 3/8" T. x 9/16"-18 Thd., O-Ring
84	23R13	1	Elbow, 90°, 1/2" Tube x 7/8"-14 Thd., O-Ring
85	28C04	4	Elbow, 90°, 3/4" Tube x 3/4"-16 Thd., O-Ring
86	13G10	2	Elbow, 90°, 3/4" Tube x 7/8"-14 Thd., O-Ring
87	23J55	5	Elbow, 90°, 1" Tube x 1-5/16"-12 Thd., O-Ring
88	23X54	1	Tee, 3/8" T. x 3/8" T. x 9/16"-18, W/ O-Ring
89	23R41	2	Elbow, 90°, 3/8" Tube x 1/2" N.P.T.F.
90	13M64	1	Elbow, 45°, 1" Tube x 1" N.P.T.F.
91	15J70	1	Elbow, 45°, 3/4" Tube x 1-1/16"-12 Thd., O-Ring
92	23J56	2	Elbow, 45°, 1" Tube x 1-5/16"-12 Thd., O-Ring
93	14T33	2	Elbow, 90°, 1-1/4" Tube x 1-1/4" J.I.C. Swivel
94	13J69	1	Tee, 1/2" Sq. Tube x 1/2" J.I.C. Swivel
95	26J04	2	Elbow, 90°, 3/4" Tube x 3/4" J.I.C. Swivel
96	14T34	2	Elbow, 90°, 1" Tube x 1" J.I.C. Swivel
97	12X09	2	Bulkhead, 3/4" Tube x 3/4" Tube
98	27R41	4	Elbow, 90°, 1" Tube x 1" Flange
99	14Y57	1	Tee, 1" Tube x 1" Tube x 1" Tube
100	12W74	2	Tee, Bulkhead, 3/8" Tube x 3/8" Tube 3/8" Tube
101	13K98	2	Elbow, 90°, 3/8" Tube x 1/2" Male N.P.T.F. x 1/16" Orifice
102	23H54	1	Connector, 1/2" T. x 3/4"-16 Str. 11x1.
103	10D99	3	Bushing, Reducing, 1" x 1-1/4"
104	23R36	1	Bushing, Reducing, 3/4" x 1-1/4"
105	28W79	4	O-Ring
106	28C06	1	Elbow, 90°, 1/4" Swivel x 7/16"-20 Str. O-Ring
107	10E09	8	Flange, 1" Split
108	27C86	2	3/4" Hex Nut
109	27L77	12	5/16" Lock Washer
110	23F55	1	Plug, 3/4"-16 Str. Thd., O-Ring
111	26C53	2	3/8" x 1" Hex Head Cap Screw
112	27L78	6	3/8" Lock Washer
113	16W90	4	1/4" x 2" Hex Head Cap Screw
114	13J31	5	1/4" x 3/4" Hex Head Cap Screw
115	27L76	15	1/4" Lock Washer
116	27L52	8	1/4" Cut Washer
117	27C90	2	3/8" Hex Nut
118	AD-80-509W	1	Hose, 1" I.D. x 35"
119	AB-80-513W	1	Hose, 1-1/4" I.D. x 35"
120	D-80-571W	1	Hose, 1-1/4" I.D. x 63"
121	D-80-516W	1	Hose, 3/4" I.D. x 33"
122	B-80-571W	1	Hose, 1-1/4" I.D. x 33"
123	AY-80-485W	1	Hose, 1" I.D. x 96"
124	BV-80-485W	1	Hose, 1" I.D. x 68"
125	BC-80-485W	1	Hose, 1" I.D. x 89"
126	AZ-80-485W	2	Hose, 1" I.D. x 63"
127	AL-80-478W	1	Hose, 1" I.D. x 57"
128	DL-80-482W	1	Hose, 3/8" I.D. x 43"
129	Y-80-510W	1	Hose, 1" I.D. x 37"
130	G-80-512W	1	Hose, 1" I.D. x 25"
131	AG-80-516W	1	Hose, 3/4" I.D. x 98"
132	AZ-80-479W	1	Hose, 3/4" I.D. x 76"

REF.	PART NUMBER	QTY.	DESCRIPTION
133	Y-80-516W	1	Hose, 3/4" I.D. x 20"
134	AJ-80-516W	1	Hose, 3/4" I.D. x 30"
135	H-80-512W	1	Hose, 1" I.D. x 41"
136	R-80-491W	2	Hose, 3/8" I.D. x 34"
137	AV-80-480W	1	Hose, 3/4" I.D. x 91"
138	N-80-479W	1	Hose, 3/4" I.D. x 34"
139	A-80-592W	1	Hose, 1-1/4" I.D. x 68"
140	D-80-491W	2	Hose, 3/8" I.D. x 46"
141	23M23	2	Plug, 1-5/8" St. Thrd., O-Ring
142	23M76	2	Connector, 1/4" N.P.T.F. x 9/16"-18, O-Ring
143	23P99	1	Elbow, 90° - 1/2" T. x 3/4"-16 Str. Thd.
144	BZ-80-491W	1	Hose, 3/8" I.D. x 41"
145	23Y11	2	1/4" x .88" Hex Head Cap Screw
146	15C75	1	Plug, 1-3/16"-12 Str. Thd. w/ O-Ring
147	23C66	2	Fitting, 1/8" N.P.T.F. x 90°
148	23C60	2	Fitting, 1/8" N.P.T.F., Str.
149	BT-80-491W	1	Hose, 3/8" I.D. x 104"
150	10E10	16	3/8" x 1-1/4" Hex Head Cap Screw
151	27L78	16	3/8" Lock Washer
201	X-80-482W	2	Hose, 3/8" I.D. x 80"
202	BK-80-491W	1	Hose, 3/8" I.D. x 71"
203	L-80-482W	1	Hose, 3/8" I.D. x 29"
204	L-80-479W	1	Hose, 3/4" I.D. x 30"
205	27Y51	3	Connector, 1/4" T. x 9/16"-18 Str. Thd., O-Ring
206	AS-80-491W	2	Hose, 3/8" I.D. x 51" (For Auto Grade Control)
207	R-80-482W	4	Hose, 3/8" I.D. x 48"
208	BZ-80-482W	2	Hose, 3/8" I.D. x 71"
	11P81	30	Tie, Plastic Wire
	10B23	15	Tie, Plastic Wire
211	BW-80-491W	1	Hose, 3/8" I.D. x 39"
212	BY-80-491W	1	Hose, 3/8" I.D. x 66"
213	DH-80-491W	2	Hose, 3/8" I.D. x 18"
214	23F70	2	Nut, 1/2" T.
215	26J12	1	Reducer, 1/2" T. x 3/8" T.
216	23H41	2	Elbow, 90° - 3/4" T. x 1-1/16"-12 Thd., O-Ring
217	CS-80-484W	1	Hose, 1/4" I.D. x 37"
218	CT-80-484W	1	Hose, 1/4" I.D. x 17"
219	AN-80-490W	1	Hose, 1/4" I.D. x 77"
220	AP-80-490W	1	Hose, 1/4" I.D. x 48"
221	N-80-508W	1	Hose, 3/4" I.D. x 78"
222	J-876-4628	2	Spacer, 3/8" Belting
223	27L58	6	1/2" Cot Washer
224	AR-80-490W	1	Hose, 1/4" I.D. x 33"
225	L-80-509W	1	Hose, 3/4" I.D. x 68"
226	EV-80-484W	2	Hose, 1/4" I.D. x 42"
227	11V33	1	Connector, 1" T. x 1-5/8"-12 Thd., O-Ring
228	16R42	2	U-Bell
229	27Y42	1	Elbow, 45° - 3/4" T. x 3/4" J.I.C., Swivel
230	20K38	1	Clamp
231	23R04	1	Connector, 3/8" O.D. x 3/4"-16 Male S.A.F. Thd.

REF.	PART NUMBER	QTY.	DESCRIPTION
232	27C95	3	1/2" Hex Nut
233	23N59	1	Connector, 1" Tube x 1" N.P.T.F.
234	12T27	1	Plug, 1" Tube
235	D-80-509W	1	Hose, 1" I.D. x 37"
236	DA-876-5283	2	Pin, 3/4" Dia. x 4-1/2"
237	26C53	4	3/8" x 1" Hex Head Cap Screw
238	BU-17-25	2	Pin, 1" Dia. x 3.88"
239	DB-876-5283	2	Bar
240	12T11	2	1/2" x 1-3/4" Flat Head Cap Screw
241	27D64	4	Pin, Cotter - 3/16" x 1-1/2"
242	B-53-1794	2	Gasket
243	13J37	15	1/2" x 1-3/4" Hex Head Cap Screw
244	C-17-478	12	Washer, 17/32" I.D. x 1" O.D. x 1/4" Thick
245	A-53-2517	4	Gasket
246	26E29	2	1/2" x 1-1/2" Hex Head Cap Screw
247	27L81	19	1/2" Lock Washer
248	26J11	1	Reducer, 1/2" T. x 1/4" T.
249	27Y53	1	Tee, 1/4" T. x 1/4" T. x 7/16"-20
250	29J32	7	Nipple, Tube End
251	29F42	7	Plug, Dust
252	29E60	2	Gauge, Vacuum
253	29M31	2	Elbow, 45° - St. x 1/4" N.P.T.F.
254	28M75	1	Coupling, 1/4" N.P.T.F.
255	23N77	1	Nipple, 1/4" N.P.T.F.
256	23R14	2	Tee, 1" T. x 1" T. x 1-5/16-12 Swivel
257	29M91	2	Connector, Reducer (With .050" Orifice)
258	C-80-496W	1	Hose, 3/8" I.D. x 58.00"
259	K-80-497W	1	Hose, 3/8" I.D. x 52.00"
260	27Y57	3	Elbow, 90° - 1/4" T. x 1/4" J.I.C. Swivel

a - Consult Barber-Greene Repair Parts Department for repairs on this item.

SINGLE CONTROL STATION HYDRAULICS

D1-876-5480B

(Before Ordering, Consult Table of Contents to Verify Proper Bill of Material Number.)

REF.	PART NUMBER	QTY.	DESCRIPTION
Ref. #138 thru #146 Symbolized by  on Ill. 2 in Sect. 10 Pgs. 2, 9, 16, 23, 30, 37 & 44.			
	12T80	1	Grommet
	28T48	1	Support, Lid
138	BT-80-491W	1	Hose, 3/8" I.D. x 104"
139	AD-80-482W	2	Hose, 3/8" I.D. x 204"
140	K-80-491W	1	Hose, 3/8" I.D. x 100"
141	28G75	1	Sleeve, Hose
142	50N78	1	Hose, 1/2" I.D. x 8"
143	16R34	1	3/8" U-Bolt
144	27L78	2	3/8" Lock Washer
145	27C90	4	3/8" Hex Nut
146	26J03	1	Elbow, 90°, 3/8" Tube x 3/8" JIC Swivel
	EB1-876-5302W	1	Plate, Deck (Right)
	27K01	1	#10-24 x 1" Round Head Machine Screw
	27N31	2	#10-24 x .50" Flat Head Machine Screw
	27L99	2	#10 Lock Washer
	27C79	2	#10-24 Hex Nut

SINGLE CONTROL STATION HYDRAULICS

D2-876-5480B

(Before Ordering, Consult Table of Contents to Verify Proper Bill of Material Number.)

REF.	PART NUMBER	QTY.	DESCRIPTION
Ref. #138 thru #146 Symbolized by  on Ill. 2 in Sect. 10 Pgs. 44, 51 & 58.			
	12T80	1	Grommet
	28T48	1	Support, Lid
138	BT-80-491W	1	Hose, 3/8" I.D. x 104"
139	AD-80-482W	2	Hose, 3/8" I.D. x 204"
140	K-80-491W	1	Hose, 3/8" I.D. x 100"
141	28G75	1	Sleeve, Hose
142	50N78	1	Hose, 1/2" I.D. x 8"
143	16R34	1	3/8" U-Bolt
144	27L78	2	3/8" Lock Washer
145	27C90	4	3/8" Hex Nut
146	26J03	1	Elbow, 90°, 3/8" Tube x 3/8" JIC Swivel
	EB-876-5502W	1	Plate, Deck (Right)
	27K01	1	#10-24 x 1" Round Head Machine Screw
	27N31	2	#10-24 x .50" Flat Head Machine Screw
	27L99	2	#10 Lock Washer
	27C79	2	#10-24 Hex Nut

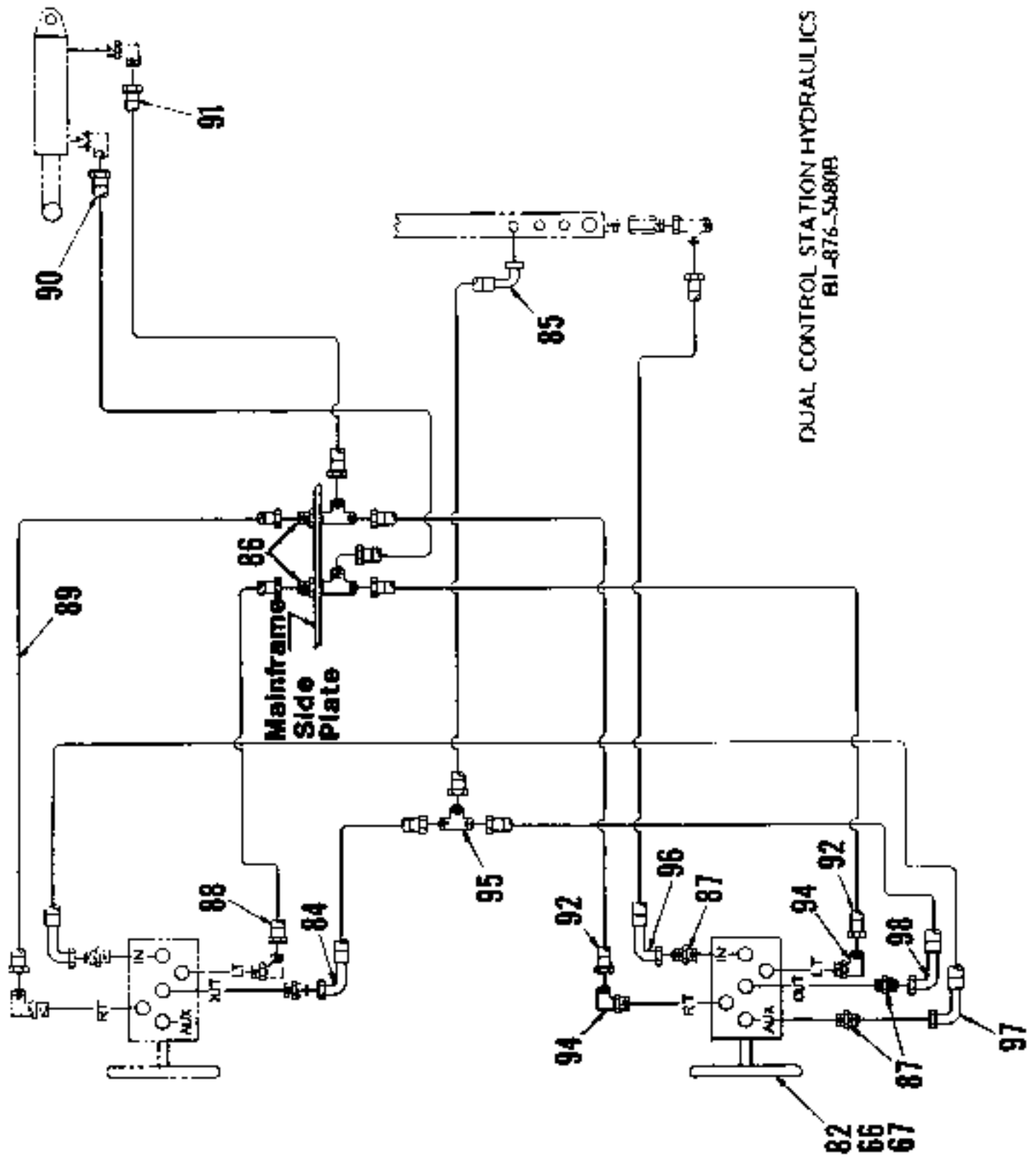

DUAL CONTROL STATION HYDRAULICS

BI-876-5480B

(Before Ordering, Consult Table of Contents to Verify Proper Bill of Material Number.)

REF.	PART NUMBER	QTY.	DESCRIPTION
Ref. #66 thru #98 Symbolized by NONE on Illustration.			
66	26E25	4	5/16" x 3/4" Hex Head Cap Screw
67	27L77	4	5/16" Lock Washer
	DDI-876-5302W	1	Plate, Right Deck
	12T80	1	Grommet
	876-5481 Sht. 4	1	Print, Dual Steering Hydraulic Assembly Drawing
	28T48	1	Support, Lid
	27K01	1	#10-24 x 1" Round Head Machine Screw
	27N31	2	#10-24 x .50" Flat Head Machine Screw
	27L99	2	#10 Lock Washer
	27C79	2	#10-24 Hex Nut
82	27Y29	1	Steering Unit
84	BR-80-491W	1	Hose, 3/8" I.D. x 77"
85	BH-80-491W	1	Hose, 3/8" I.D. x 41"
86	13G89	2	Tee, Bulkhead, 3/8" Tube x 3/8" Tube x 3/8" Tube - 3/4" Std.
87	23W72	3	Connector, 1/2" Tube x 9/16"-18 Thd.
88	P-80-482W	1	Hose, 3/8" I.D. x 40"
89	BV-80-482W	1	Hose, 3/8" I.D. x 41"
90	CE-80-482W	1	Hose, 3/8" I.D. x 111"
91	CF-80-482W	1	Hose, 3/8" I.D. x 121"
92	Y-80-482W	2	Hose, 3/8" I.D. x 97"
94	23P61	2	Elbow, 90°, 3/8" Tube x 9/16"-18 Thd., O-Ring
95	12X40	1	Tee, 3/8" Tube x 3/8" Tube x 3/8" Tube
96	BP-80-491W	1	Hose 3/8" I.D. x 77"
97	C-80-497W	1	Hose, 3/8" ID. x 138"
98	BS-80-491W	1	Hose, 3/8" I.D. x 64"

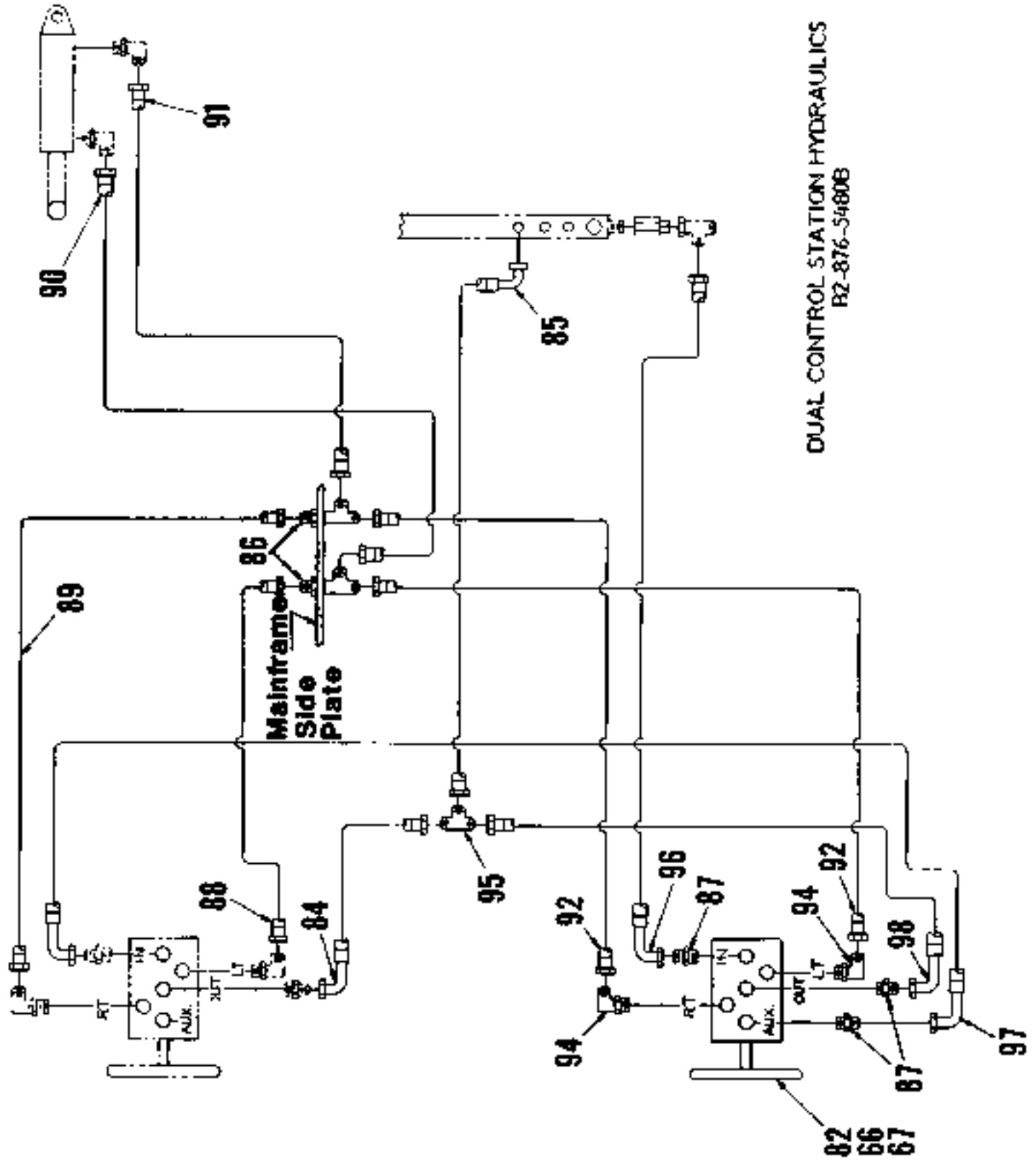

DUAL CONTROL STATION HYDRAULICS

B2-876-5480B

(Before Ordering, Consult Table of Contents to Verify Proper Bill of Material Number.)

REF.	PART NUMBER	QTY.	DESCRIPTION
Ref. #66 thru #98 Symbolized by NONE on Illustration.			
66	26E25	4	5/16" x 3/4" Hex Head Cap Screw
67	27L77	4	5/16" Lock Washer
	GB-876-5502W	1	Plate, Deck (Right)
	12T80	1	Grommet
	876-5481 Sht. 4	1	Print, Dual Steering Hydraulic Assembly Drawing
	28T4B	1	Support, Lid
	27K01	1	#10-24 x 1" Round Head Machine Screw
	27N31	2	#10-24 x .50" Flat Head Machine Screw
	27L99	2	#10 Lock Washer
	27C79	2	#10-24 Hex Nut
82	27Y29	1	Steering Unit
84	BR-80-491W	1	Hose, 3/8" I.D. x 77"
85	BH-80-491W	1	Hose, 3/8" I.D. x 41"
86	13G89	2	Tee, Bulkhead, 3/8" Tube x 3/8" Tube x 3/8" Tube - 3/4" Std.
87	23W77	3	Connector, 1/2" Tube x 9/16"-18 Thd.
88	P-80-482W	1	Hose, 3/8" I.D. x 40"
89	BV-80-482W	1	Hose, 3/8" I.D. x 41"
90	CE-80-482W	1	Hose, 3/8" I.D. x 111"
91	CF-80-482W	1	Hose, 3/8" I.D. x 121"
92	Y-80-482W	2	Hose, 3/8" I.D. x 97"
94	23P61	2	Elbow, 90°, 3/8" Tube x 9/16"-18 Thd.- O-Ring
95	12X40	1	Tee, 3/8" Tube x 3/8" Tube x 3/8" Tube
96	BP-80-491W	1	Hose 3/8" I.D. x 77"
97	C-80-492W	1	Hose, 3/8" I.D. x 138"
98	BS-80-491W	1	Hose, 3/8" I.D. x 64"

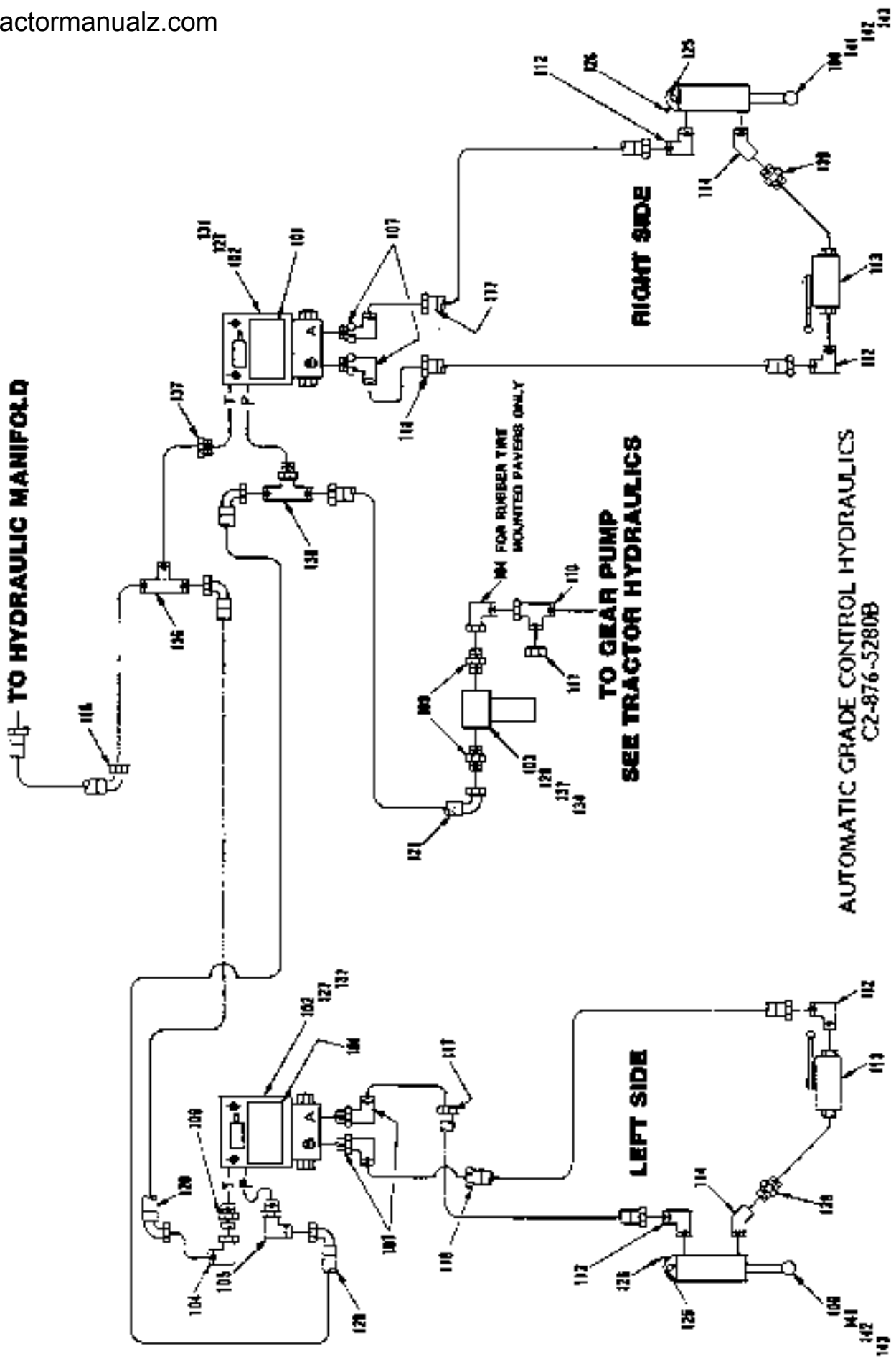

AUTOMATIC GRADE CONTROL HYDRAULICS

C2-876-5280B

(Before Ordering, Consult Table of Contents to Verify Proper Bill of Material Number.)

REF.	PART NUMBER	QTY.	DESCRIPTION
Ref. #100 thru #143 Symbolized by NONE on Illustration.			
100	28W09	2	Cylinder, Hydraulic (Grade Control) (See Section 12 For Breakdown)
101 ^a	28T59	2	Valve, Servo
102	28T58	2	Manifold, Servo (Each Servo Manifold Consisting in part of the following indented items):
	28T58C1	1	. Valve, Three-Way Solenoid
	28T58C2	1	. Valve, Lock
	28T58C3	2	. O-Ring
103	27X86	1	Filter, Hydraulic Oil (Consisting in part of the following indented items):
	27X86C1	1	. Element & O-Ring Assembly
	27X86C2	1	. O-Ring, Filter Housing
104	26J03	2	Elbow, 90°, Swivel, 3/8" T. x 3/8" J.I.C. (This Part Required for BG-220B Asphalt Paver Only)
105	23P61	1	Elbow, 90°, 3/8" T. x 9/16"-18 Str. Thd., O-Ring
106	23R05	1	Connector, 3/8" T. x 9/16"-18 Str. Thd., O-Ring
107	27Y50	4	Elbow, 90°, 1/4" T. x 9/16"-18 Str. Thd., O-Ring
109	27Y62	2	Connector, 3/8" Tube x 1-1/16"-12 Str. Thd.
110	23T03	1	Tee, Swivel, 3/8" Tube x 3/8" Tube x 3/8" Swivel
111	17T24	1	Cap, 3/8" Tube
112	23F61	4	Elbow, 90°, 1/4" Tube x 1/4" N.P.T.F.
113	28W07	2	Valve, Ball
114	23K05	2	Elbow, 45° - ST. x 1/4" N.P.T.F.
116	BK-80-491W	1	Hose, 3/8" I.D. x 71"
117	FX-80-484W	2	Hose, 1/4" I.D. x 17"
118	G-80-484W	2	Hose 1/4" I.D. x 26"
120	J-80-492W	2	Hose, 3/8" I.D. x 112"
121	BG-80-491W	1	Hose, 3/8" I.D. x 16"
125	50D61	2	Pin, Roll - 1/4" Dia. x 1-3/4"
126	23C64	2	Fitting, 45° x 1/8" N.P.T.F.
127	26K59	4	1/4" x 2.75" Hex Head Cap Screw
129	26K60	2	1/4" x 3-1/2" Hex Head Cap Screw
131	27L76	6	1/4" Lock Washer
134	ZZ-17-18	2	Spacer, 1/8" Pipe x 1.12"
136	11K44	1	Tee, 3/8" T. x 3/8" T. x 1/4" N.P.T.F.
137	23M76	1	Connector, 1/4" N.P.T.F. x 9/16"-18 Str. Thd., O-Ring
138	13X21	1	Tee, 3/8" T. x 3/8" T. x 9/16"-18 Str. Thd., O-Ring
139	23M79	2	Nipple, 1/4" N.P.T.F.
141	28W06	2	Fastpin
142	28W07	2	Bushing, Tension
143	14D17	2	Bushing, Spherical

^a - Consult Barber-Greene Repair Parts Department for repairs on this item.

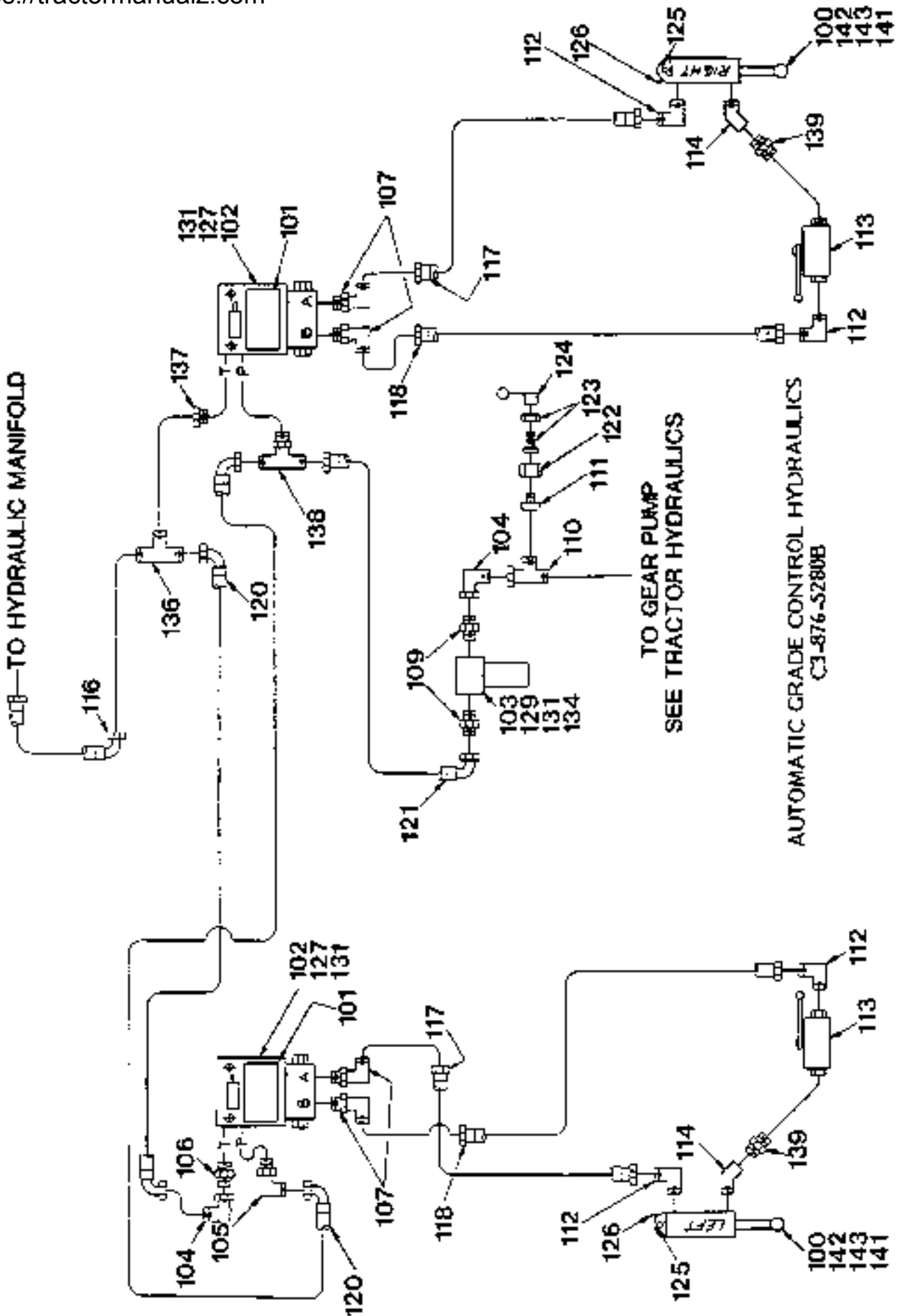

8/20/91 (16-A)

AUTOMATIC GRADE CONTROL HYDRAULICS

C3-876-5280B

(Before Ordering, Consult Table of Contents to Verify Proper Bill of Material Number.)

REF.	PART NUMBER	QTY.	DESCRIPTION
Ref. #100 thru #143 Symbolized by NONE on Illustration.			
100	28W09	2	Cylinder, Hydraulic (Grade Control) (See Section 12 For Breakdown)
101	a 28T59	2	Valve, Servo
102	28T58	2	Manifold, Servo (Each Servo Manifold Consisting in part of the following indented items):
	28T58C1	1	. Valve, Three-Way Solenoid
	28T58C2	1	. Valve, Lock
	28T58C3	2	. O-Ring
103	27X86	1	Filter, Hydraulic Oil (Consisting in part of the following indented items):
	27XB6C1	1	. Element & O-Ring Assembly
	27XB6C2	1	. O-Ring, Filter Housing
104	26J03	2	Elbow, 90°, Swivel, 3/8" T. x 3/8" J.I.C. (This Part Required for BG-220B Asphalt Paver Only)
105	23P61	1	Elbow, 90°, 3/8" T. x 9/16"-18 Str. Thd., O-Ring
106	23R05	1	Connector, 3/8" T. x 9/16"-18 Str. Thd., O-Ring
107	27Y50	4	Elbow, 90°, 1/4" T. x 9/16"-18 Str. Thd., O-Ring
109	27Y62	2	Connector, 3/8" Tube x 1-1/16"-12 Str. Thd.
110	23T03	1	Tee, Swivel, 3/8" Tube x 3/8" Tube x 3/8" Swivel
111	26J10	1	Reducer, Tube - 3/8" T. x 1/4" T.
112	23F61	4	Elbow, 90°, 1/4" Tube x 1/4" N.P.T.F.
113	28W02	2	Valve, Ball
114	23K05	2	Elbow, 45° - ST. x 1/4" N.P.T.F.
116	BK-80-491W	1	Hose, 3/8" I.D. x 71"
117	FX-80-484W	2	Hose, 1/4" I.D. x 17"
118	G-80-484W	2	Hose 1/4" I.D. x 26"
120	J-80-492W	2	Hose, 3/8" I.D. x 112"
121	BG-80-491W	1	Hose, 3/8" I.D. x 16"
122	23L49	1	Nut, Tube - 3/8" T.
123	29J32	1	Nipple, Tube End
124	29F42	1	Plug, Dust
125	50D61	2	Pin, Roll - 1/4" Dia. x 1-3/4"
126	23C64	2	Fitting, 45° x 1/8" N.P.T.F.
127	26K59	4	1/4" x 2.75" Hex Head Cap Screw
129	26K60	2	1/4" x 3-1/2" Hex Head Cap Screw
131	27L76	6	1/4" Lock Washer
134	77-17-18	2	Spacer, 1/8" Pipe x 1.12"
136	11K44	1	Tee, 3/8" T. x 3/8" T. x 1/4" N.P.T.F.
137	23M76	1	Connector, 1/4" N.P.T.F. x 9/16"-18 Str. Thd., O-Ring
138	13X21	1	Tee, 3/8" T. x 3/8" T. x 9/16"-18 Str. Thd., O-Ring
139	23M79	2	Nipple, 1/4" N.P.T.F.
141	28W06	2	Fastpin
142	28W07	2	Bushing, Tension
143	14D17	2	Bushing, Spherical

a - Consult Barber-Greene Repair Parts Department for repairs on this item.

AUTOMATIC GRADE CONTROL HYDRAULICS
C4-876-S280B

8/20/91 (16-5)

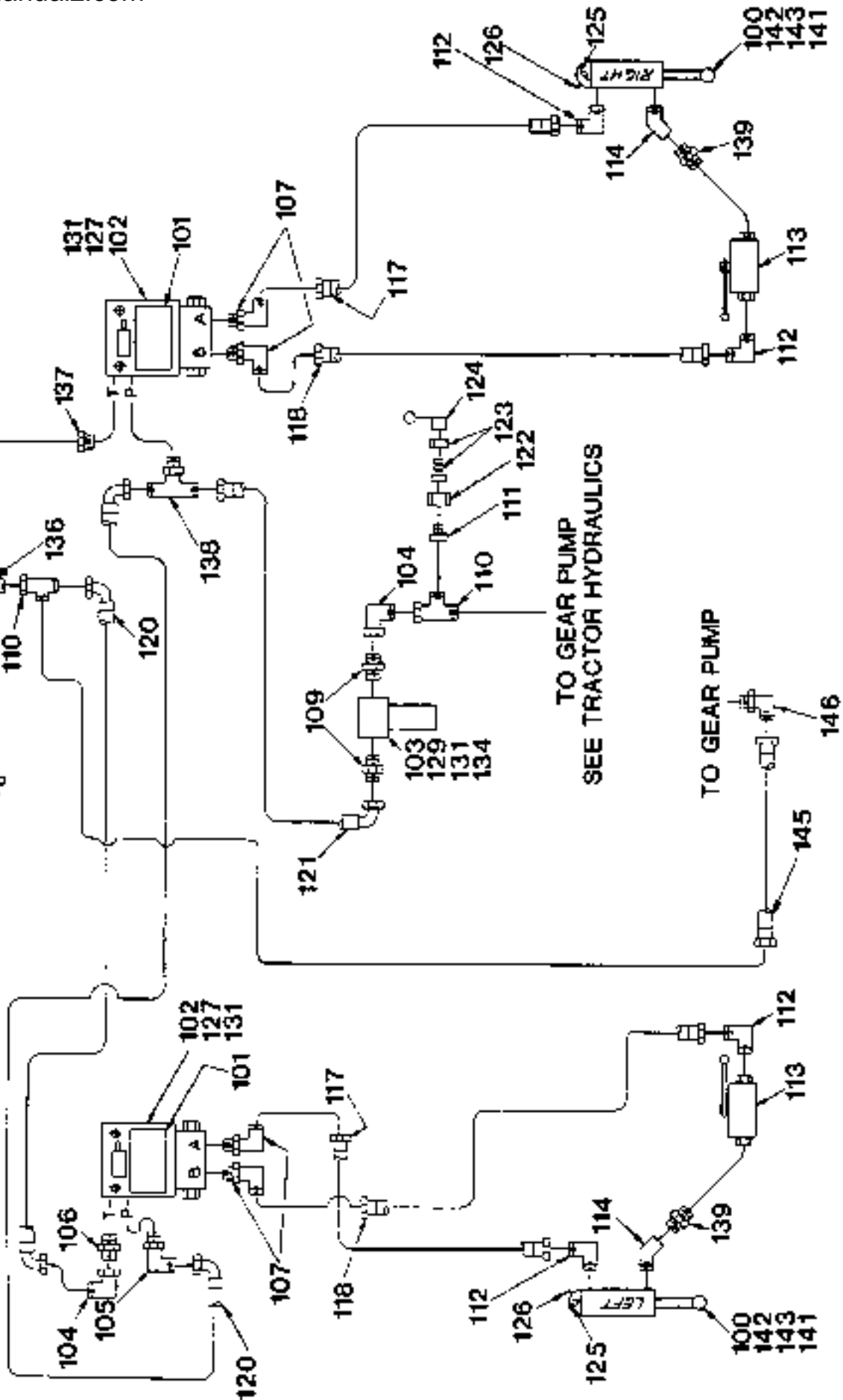

AUTOMATIC GRADE CONTROL HYDRAULICS

C4-876-52803

(Before Ordering, Consult Table of Contents to Verify Proper Bill of Material Number.)

REF.	PART NUMBER	QTY.	DESCRIPTION
Ref. #100 thru #146 Symbolized by NONE on Illustration.			
100	28W09	2	Cylinder, Hydraulic (Grade Control) (See Section 12 For Breakdown)
101	28T59	2	Valve, Servo
102	28T58	2	Manifold, Servo (Each Servo Manifold Consisting in part of the following indented items):
	28T58C1	1	• Valve, Three-Way Solenoid
	28T58C2	1	• Valve, Lock
	28T58C3	2	• O-Ring
103	27X86	1	Filter, Hydraulic Oil (Consisting in part of the following indented items):
	27X86C1	1	• Element & O-Ring Assembly
	27X86C2	1	• O-Ring, Filter Housing
104	26J03	2	Elbow, 90°, Swivel, 3/8" T. x 3/8" J.I.C. (This Part Required for BG-220B Asphalt Paver Only)
105	23P61	1	Elbow, 90°, 3/8" T. x 9/16"-18 Str. Thd., O-Ring
106	23R05	1	Connector, 3/8" T. x 9/16"-18 Str. Thd., O-Ring
107	27Y50	4	Elbow, 90°, 1/4" T. x 9/16"-18 Str. Thd., O-Ring
109	27Y62	2	Connector, 3/8" Tube x 1-1/16"-12 Str. Thd.
110	23T03	2	Tee, Swivel, 3/8" Tube x 3/8" Tube x 3/8" Swivel
111	26J10	1	Reducer, Tube - 3/8" T. x 1/4" T.
112	23F61	4	Elbow, 90°, 1/4" Tube x 1/4" N.P.T.F.
113	28W02	2	Valve, Ball
114	23K05	2	Elbow, 45° - ST. x 1/4" N.P.T.F.
116	BK-80-491W	1	Hose, 3/8" I.D. x 71"
117	FX-80-484W	2	Hose, 1/4" I.D. x 17"
118	G-80-484W	2	Hose 1/4" I.D. x 26"
120	J-80-492W	2	Hose, 3/8" I.D. x 112"
121	BG-80-491W	1	Hose, 3/8" I.D. x 16"
122	23L49	1	Nut, Tube - 3/8" T.
123	29J32	1	Nipple, Tube End
124	29F42	1	Plug, Dust
125	50D61	2	Pin, Roll - 1/4" Dia. x 1-3/4"
126	23C64	2	Fitting, 45° x 1/8" N.P.T.F.
127	26K59	4	1/4" x 2.75" Hex Head Cap Screw
129	26K60	2	1/4" x 3-1/2" Hex Head Cap Screw
131	27L76	6	1/4" Lock Washer
134	ZZ-17-18	2	Spacer, 1/8" Pipe x 1.12"
136	11K44	1	Tee, 3/8" T. x 3/8" T. x 1/4" N.P.T.F.
137	23M76	1	Connector, 1/4" N.P.T.F. x 9/16"-18 Str. Thd., O-Ring
138	13X21	1	Tee, 3/8" T. x 3/8" T. x 9/16"-18 Str. Thd., O-Ring
139	23M79	2	Nipple, 1/4" N.P.T.F.
141	28W06	2	Fastpin
142	28W07	2	Bushing, Tension

REF.	PART NUMBER	QTY.	DESCRIPTION
143	14D17	2	Bushing, Spherical
145	N80-492W	1	Hose, 3/8" I.D. x 38"
146	14L07	1	Elbow, 90° - 3/8" T. x 3/4" Str. Thd., O-Ring

a - Consult Barber-Greene Repair Parts Department for repairs on this item.

SECTION 11

BG-220B Asphalt Paver

MISCELLANEOUS TRACTOR COMPONENTS

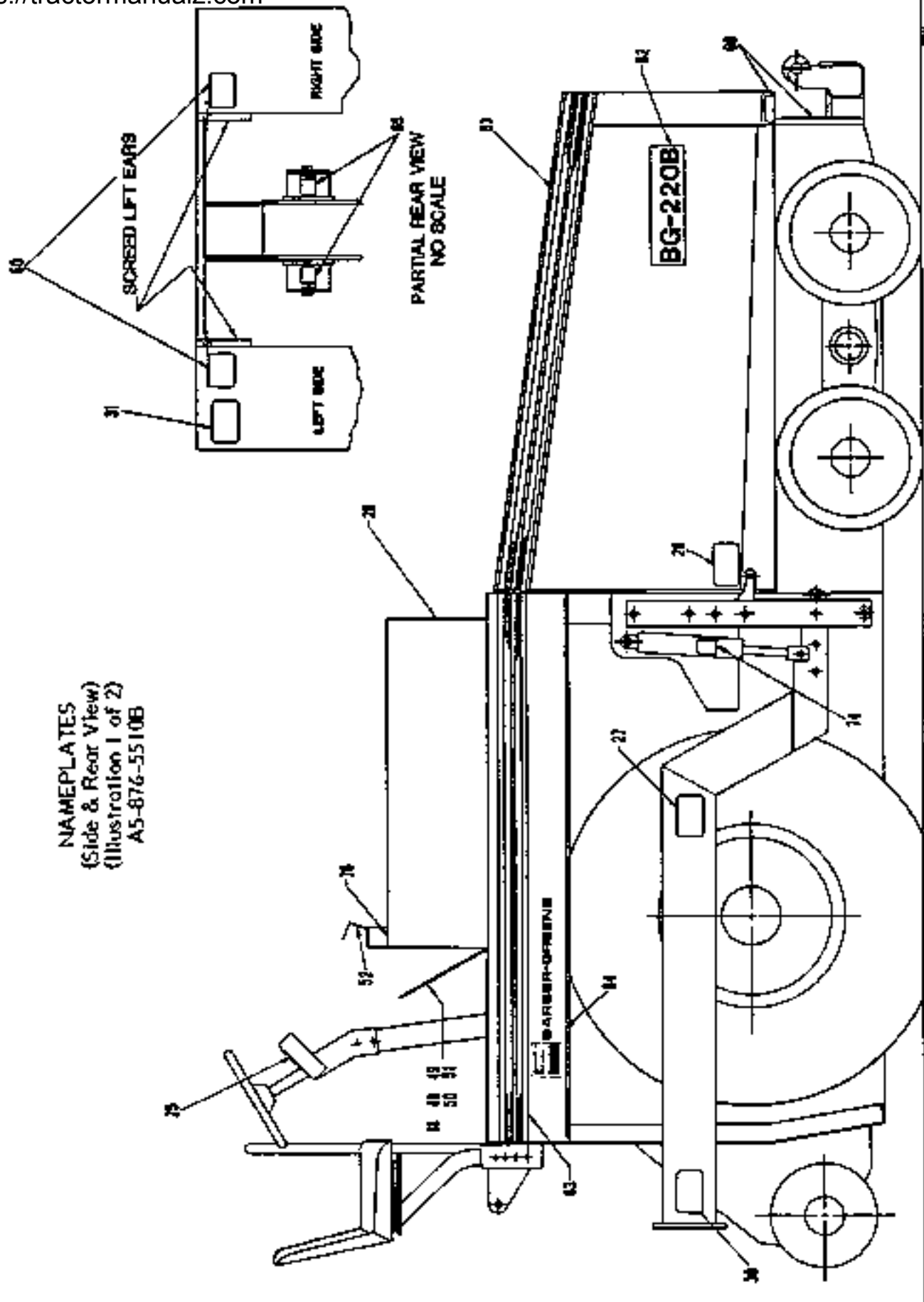

NAMEPLATES
(Side & Rear View)
(Illustration 1 of 2)
A5-876-5510B

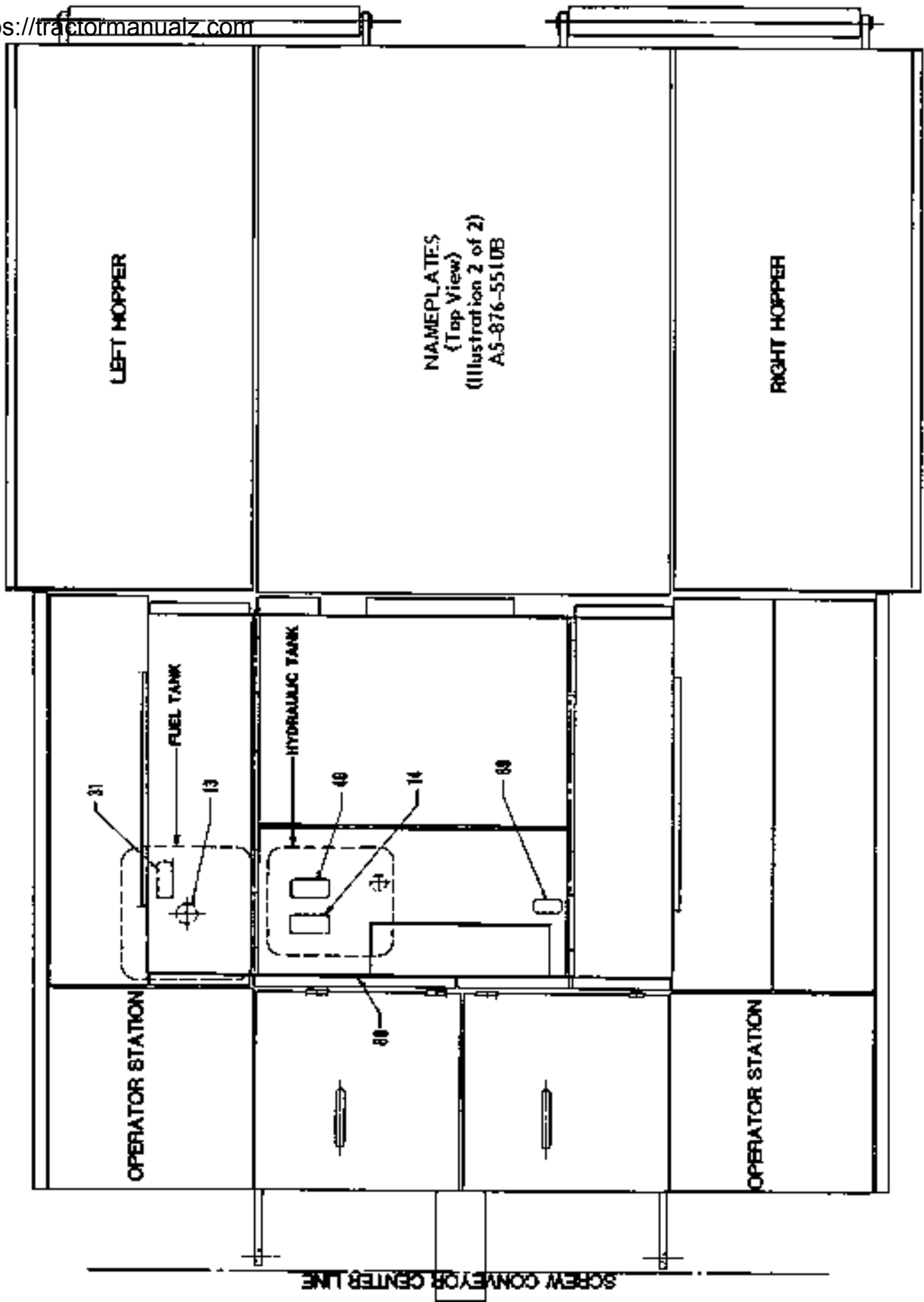

NAMEPLATES

A5-876-5510B

(Before Ordering, Consult Table of Contents to Verify Proper Bill of Material Number.)

REF.	PART NUMBER	QTY.	DESCRIPTION
Ref. #13 thru #76 Symbolized by NONE on Illustrations 1 & 2.			
	A2-46-1997	1	Nameplate, "PATENT PENDING PLATE"
	A-46-58	1	Nameplate, "MACHINE SERIAL NUMBER"
	26A77	8	#10 X 3/8" Drive Screw
	A-46-1998	1	Tag, Filter Notice
13	A-46-967	1	Decal, "FUEL"
14	A-46-2008	1	Decal, Hydraulic Tank Instructions
	C-46-1836	1	Decal, Lubrication
18	D-46-1836	1	Decal, Warranty Notice
25	A-46-1928	2	Decal, "WARNING AVOID PERSONAL INJURIES AND PROPERTY DAMAGE" (Before You Assemble, Operate, Clean, Lubricate, or Adjust Machinery, Be Sure to Read and Carefully Follow Manufacturer's written instructions.)
27	A-46-1993	2	Decal, "CAUTION PINCH POINT AREA" (Keep Clear While Machine is in Operation.)
29	B-46-1993	2	Decal, "CAUTION STAND CLEAR" (Hopper Wings Raise and Lower By Remote Control.)
29	C-46-1993	1	Decal, "CAUTION DO NOT STAND IN HOPPER WHEN ENGINE IS RUNNING"
30	D-46-1993	2	Decal, "CAUTION STAND CLEAR-MATERIAL DISCHARGE AREA"
31	E-46-1993	2	Decal, "CAUTION NO SMOKING" (Within 50 Feet During Fueling or Washdown.)
	AG-876-4648	1	Strap, Hopper Shipping
	26E29	2	1/2" x 1-1/2" Hex Head Cap Screw
	26A38	2	1/2" Lock Nut
40	A-46-2065	1	Decal, "HYDRAULIC OIL ONLY"
	50J03	2	Grip, Handle (For Screed Travel Support Levers)
	50J04	4	Grip, Rubber Handle
48	B-46-2216	1	Chart, Lubrication
49	A-46-2216	1	Chart, Lubrication
50	A2-46-2242	1	Schematic, Electrical
51	A3-46-2218	1	Schematic, Hydraulic
52	A1-46-2219	1	Decal, Loading
58	27D53	9	Pin, Cotter - 1/8" x 1"
60	A-46-2085	4	Decal, "LIFT HERE"
62	A1-46-2240	2	Decal, "BG220B"
63	G-46-2240	4	Stripe, Hopper & Tractor
64	A-46-2259	2	Decal, Logo W/ "BARBER-GREENE"
65	A-46-2263	2	Decal (Oil Level)
66	A-46-2252	1	Decal, "BARBER-GREENE" (With Logo) (Located on Rear of Tractor Unit)
69	A-46-2229	1	Decal, Caution Grade

REF.	PART NUMBER	QTY.	DESCRIPTION
	27X87	1	Filter (Grade Control)
	16X52	3	Element, Hydraulic Filter
74	A-46-2280	2	Decal, "CAUTION WHEN AUTOMATIC GRADE CONTROL IS NOT IN USE PIN CYLINDER"
76	A-46-2253	1	Nameplate, "TRAVEL - PAVE - TRANS SHIFT"
	26A76	2	#4 x 5/16" Drive Screw
	A-46-2256	1	Tag, Engine Oil Drain Notice
	A1-46-2254	2	Decal "200 SERIES"
	A-46-1779	1	Indicator, Gate

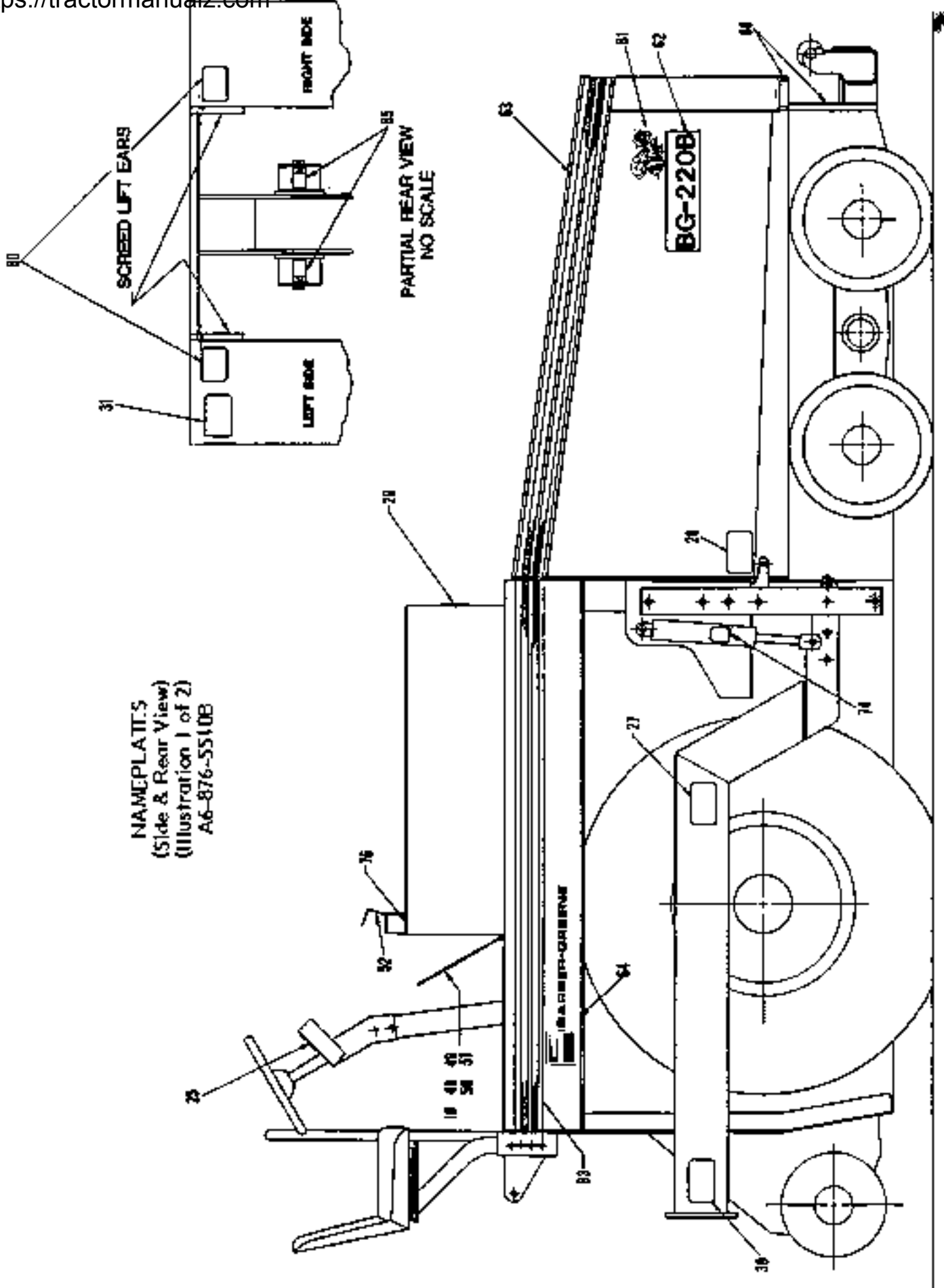

NAMEPLATE'S
(Side & Rear View)
(Illustration 1 of 2)
A6-876-5510B

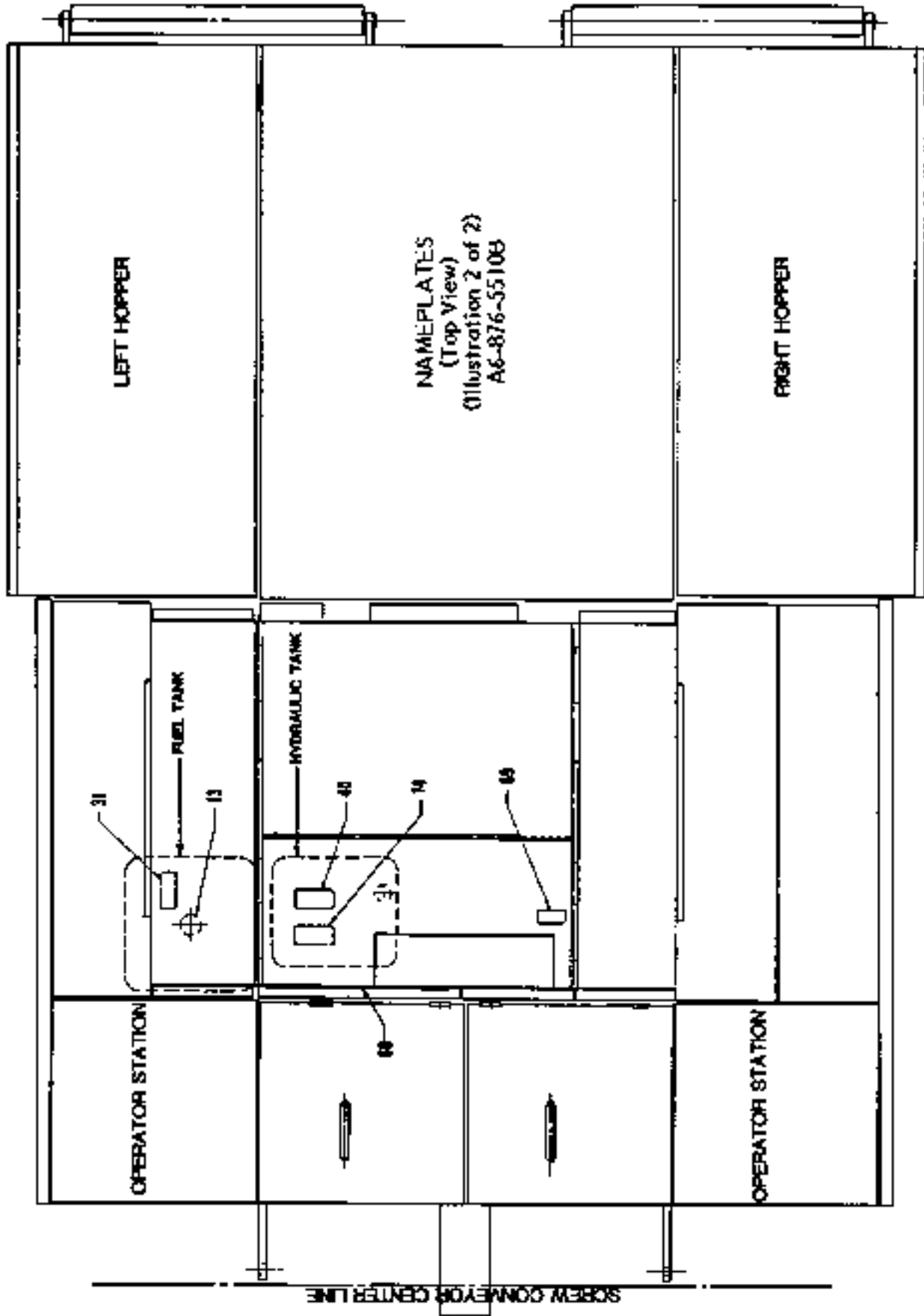

NAMEPLATES

A6-876-5510B

(Before Ordering, Consult Table of Contents to Verify Proper Bill of Material Number.)

REF.	PART NUMBER	QTY.	DESCRIPTION
Ref. #13 thru #76 Symbolized by NONE on Illustrations 1 & 2.			
	A2-46-1997	1	Nameplate, "PATENT PENDING PLATE"
	A-46-5B	1	Nameplate, "MACHINE SERIAL NUMBER"
	26A77	8	#10 X 3/8" Drive Screw
	A-46-199B	1	Tag, Filter Notice
13	A-46-967	1	Decal, "FUEL"
14	A-46-2008	1	Decal, Hydraulic Tank Instructions
	C-46-1836	1	Decal, Lubrication
18	D-46-1836	1	Decal, Warranty Notice
25	A-46-192B	2	Decal, "WARNING AVOID PERSONAL INJURIES AND PROPERTY DAMAGE" (Before You Assemble, Operate, Clean, Lubricate, or Adjust Machinery, Be Sure to Read and Carefully Follow Manufacturer's written instructions.)
27	A-46-1993	2	Decal, "CAUTION PINCH POINT AREA" (Keep Clear While Machine is in Operation.)
28	B-46-1993	2	Decal, "CAUTION STAND CLEAR" (Hopper Wings Raise and Lower By Remote Control.)
29	C-46-1993	1	Decal, "CAUTION DO NOT STAND IN HOPPER WHEN ENGINE IS RUNNING"
30	D-46-1993	2	Decal, "CAUTION STAND CLEAR-MATERIAL DISCHARGE AREA"
31	E-46-1993	2	Decal, "CAUTION NO SMOKING" (Within 50 Feet During Fueling or Washdown.)
	AG-876-4648	1	Strap, Hopper Shipping
	26E29	2	1/2" x 1-1/2" Hex Head Cap Screw
	26A38	2	1/2" Lock Nut
40	A-46-2065	1	Decal, "HYDRAULIC OIL ONLY"
	50J03	2	Grip, Handle (For Screed Travel Support Levers)
	50J04	4	Grip, Rubber Handle
48	B-46-2216	1	Chart, Lubrication
49	A-46-2216	1	Chart, Lubrication
50	A2-46-2242	1	Schematic, Electrical
51	A3-46-2218	1	Schematic, Hydraulic
52	A2-46-2219	1	Decal, Loading
58	27D53	9	Pin, Cotter - 1/8" x 1"
60	A-46-2085	4	Decal, "LIFT HERE"
61	A-46-2290	2	Decal (Barber-Greene Bee With Hard Hat)
62	A1-46-2240	2	Decal, "BG220B"
63	G-46-2240	4	Stripe, Hopper & Tractor
64	A-46-2259	2	Decal, Logo W/ "BARBER-GREENE"
65	A-46-2263	2	Decal (Oil Level)
66	A-46-2252	1	Decal, "BARBER-GREENE" (With Logo) (Located on Rear of Tractor Unit)

REF.	PART NUMBER	QTY.	DESCRIPTION
69	A-46-2229	1	Decal, Caution Grade
	27X87	1	Filter (Grade Control)
	16XS2	3	Element, Hydraulic Filter
74	A-46-2280	2	Decal, "CAUTION WHEN AUTOMATIC GRADE CONTROL IS NOT IN USE PIN CYLINDER"
76	A-46-2253	1	Nameplate, "TRAVEL - PAVE - TRANS SHIFT"
	26A76	2	#4 x 5/16" Drive Screw
	A-46-2256	1	Tag, Engine Oil Drain Notice
	A-46-2254	2	Decal "200 SERIES"
	A-46-1779	1	Indicator, Gate

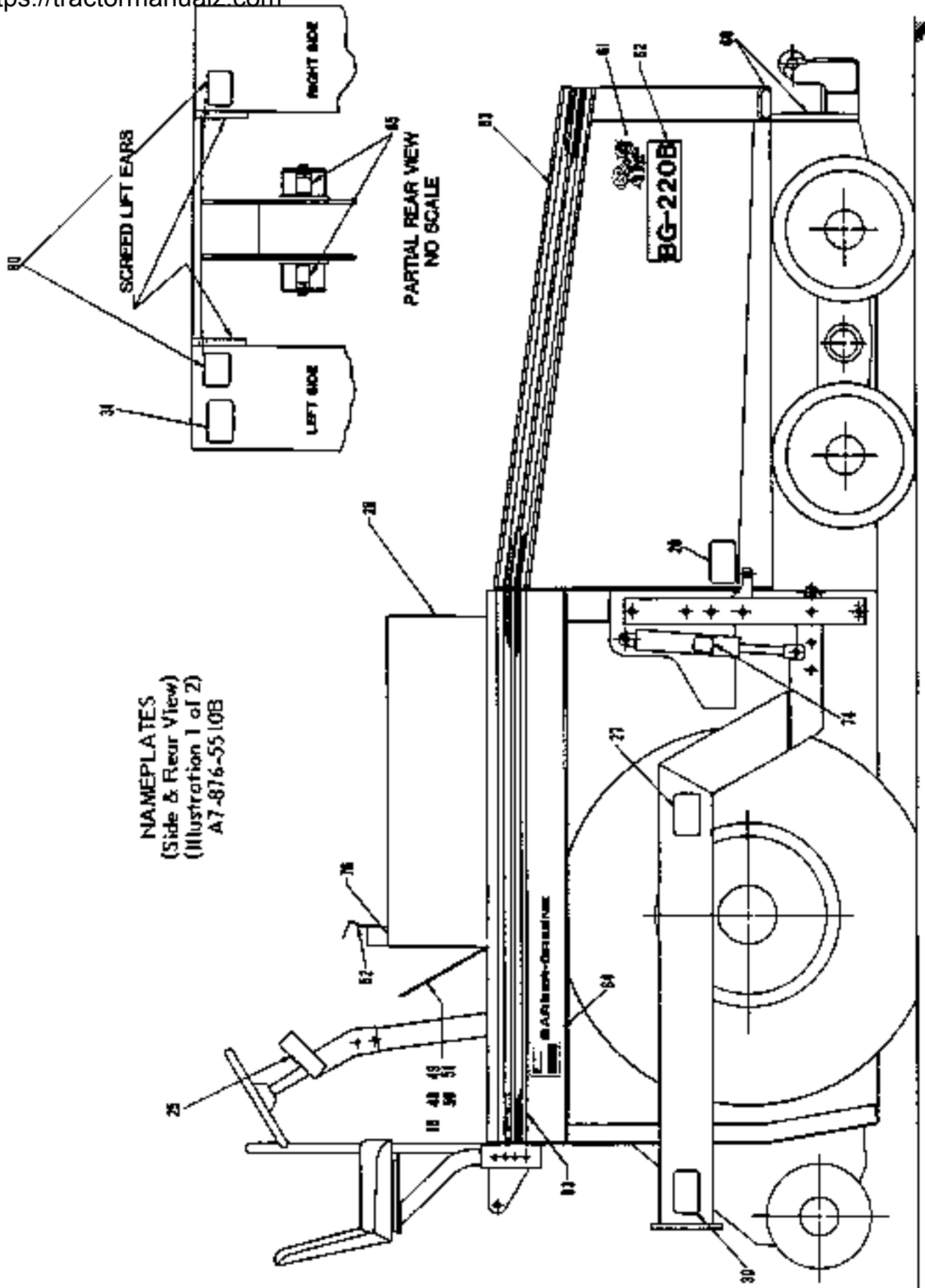

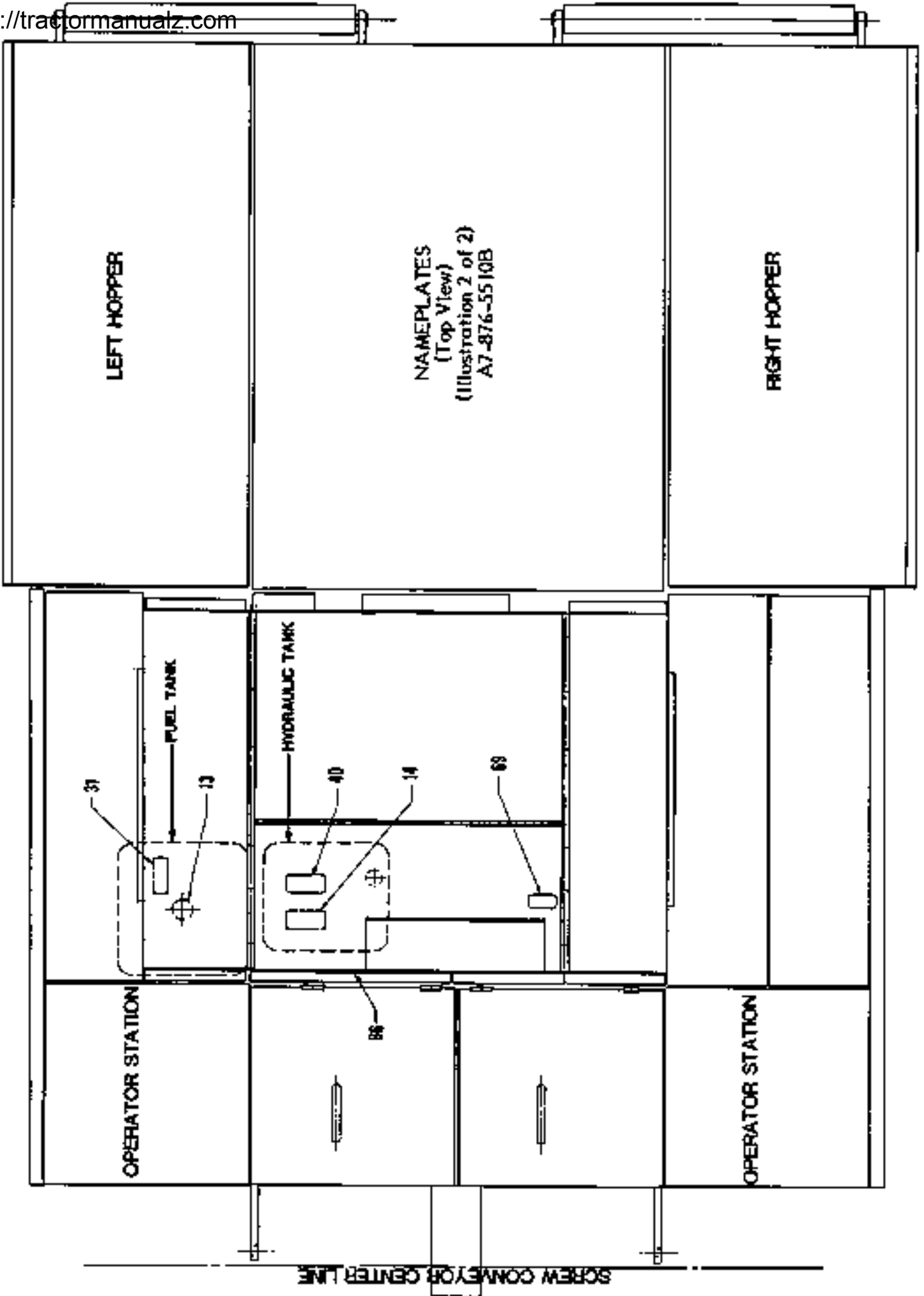

2/25/89 (2-0)

NAMEPLATES

A7-876-5510B

(Before Ordering, Consult Table of Contents to Verify Proper Bill of Material Number.)

REF.	PART NUMBER	QTY.	DESCRIPTION
Ref. #13 thru #76 Symbolized by NONE on Illustrations 1 & 2.			
	A2-46-1997	1	Nameplate, "PATENT PENDING PLATE"
	A-46-58	1	Nameplate, "MACHINE SERIAL NUMBER"
	26A77	8	#10 X 3/8" Drive Screw
	A-46-1998	1	Tag, Filter Notice
13	A-46-967	1	Decal, "FUEL"
14	A-46-2008	1	Decal, Hydraulic Tank Instructions
	C-46-1836	1	Decal, Lubrication
18	D-46-1836	1	Decal, Warranty Notice
25	A-46-1928	2	Decal, "WARNING AVOID PERSONAL INJURIES AND PROPERTY DAMAGE" (Before You Assemble, Operate, Clean, Lubricate, or Adjust Machinery, Be Sure to Read and Carefully Follow Manufacturer's written instructions.)
27	A-46-1993	2	Decal, "CAUTION PINCH POINT AREA" (Keep Clear While Machine Is in Operation.)
28	B-46-1993	2	Decal, "CAUTION STAND CLEAR" (Hopper Wings Raise and Lower By Remote Control.)
29	C-46-1993	1	Decal, "CAUTION DO NOT STAND IN HOPPER WHEN ENGINE IS RUNNING"
30	D-46-1993	2	Decal, "CAUTION STAND CLEAR-MATERIAL DISCHARGE AREA"
31	E-46-1993	2	Decal, "CAUTION NO SMOKING" (Within 50 Feet During Fueling or Washdown.)
	AG-876-4648	1	Strap, Hopper Shipping
	26E29	2	1/2" x 1-1/2" Hex Head Cap Screw
	26A38	2	1/2" Lock Nut
40	A-46-2065	1	Decal, "HYDRAULIC OIL ONLY"
	50J03	2	Grip, Handle (For Screed Travel Support Levers)
	50J04	4	Grip, Rubber Handle
48	B-46-2216	1	Chart, Lubrication
49	A-46-2216	1	Chart, Lubrication
50	A3-46-2242	1	Schematic, Electrical
51	A4-46-2218	1	Schematic, Hydraulic
52	A2-46-2219	1	Decal, Loading
58	27D53	9	Pin, Cutter - 1/8" x 1"
60	A-46-2085	4	Decal, "LIFT HERE"
61	A-46-2290	2	Decal (Barber-Greene Bee With Hard Hat)
62	A1-46-2240	2	Decal, "BG220B"
63	G-46-2240	4	Stripe, Hopper & Tractor
64	A-46-2259	2	Decal, Logo W/ "BARBER-GREENE"
65	A-46-2263	2	Decal (Oil Level)
66	A-46-2252	1	Decal, "BARBER-GREENE" (With Logo) (Located on Rear of Tractor Unit)

REF.	PART NUMBER	QTY.	DESCRIPTION
69	A-46-2229	1	Decal, Caution Grade
	27X87	1	Filter (Grade Control)
	16X52	3	Element, Hydraulic Filter
74	A-46-2280	2	Decal, "CAUTION WHEN AUTOMATIC GRADE CONTROL IS NOT IN USE PIN CYLINDER"
76	A-46-2253	1	Nameplate, "TRAVEL - PAVE - TRANS SHIFT"
	26A76	2	#4 x 5/16" Drive Screw
	A-46-2256	1	Tag, Engine Oil Drain Notice
	A-46-2254	2	Decal "200 SERIES"
	A-46-1779	1	Indicator, Gate

NAMEPLATES
(Side & Rear View)
(Illustration 1 of 2)
A8-876-5510B

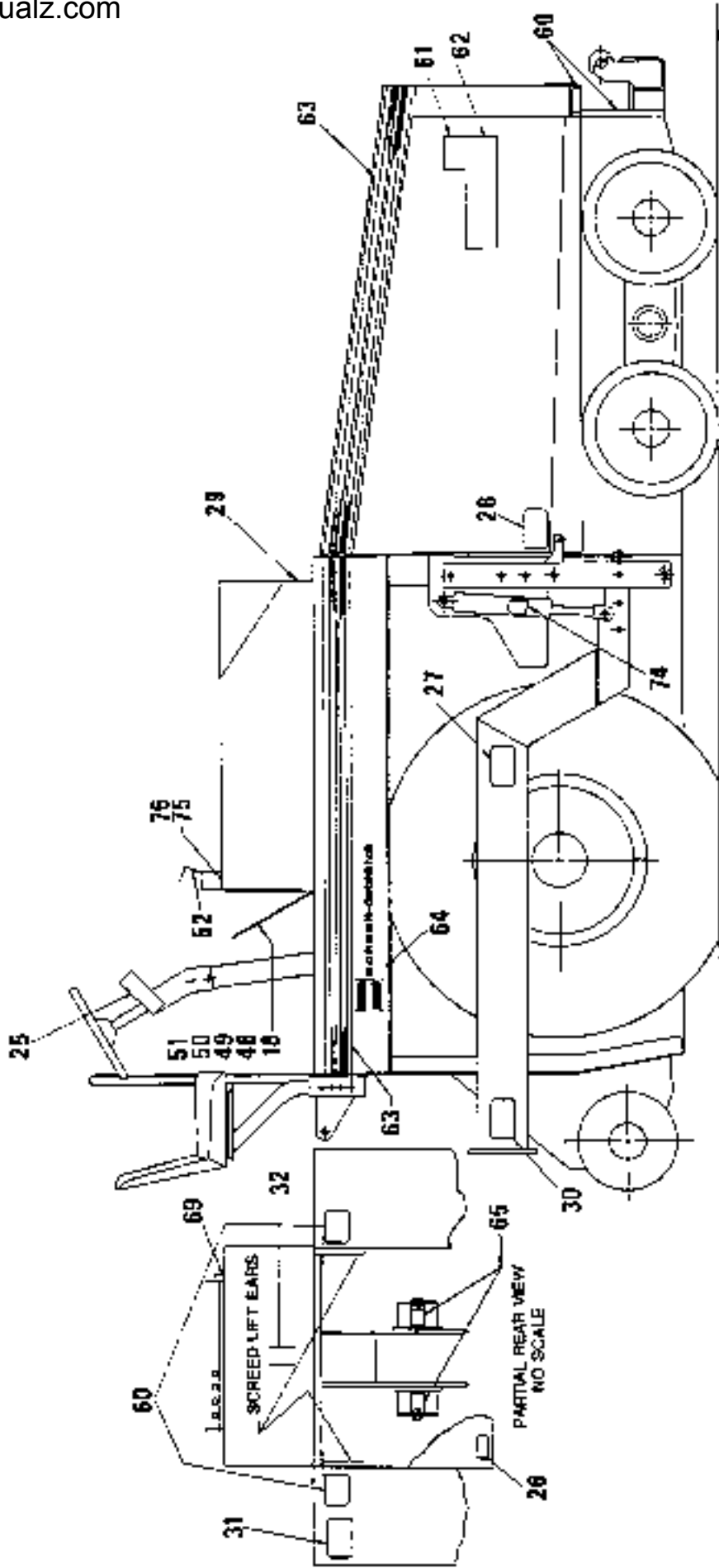

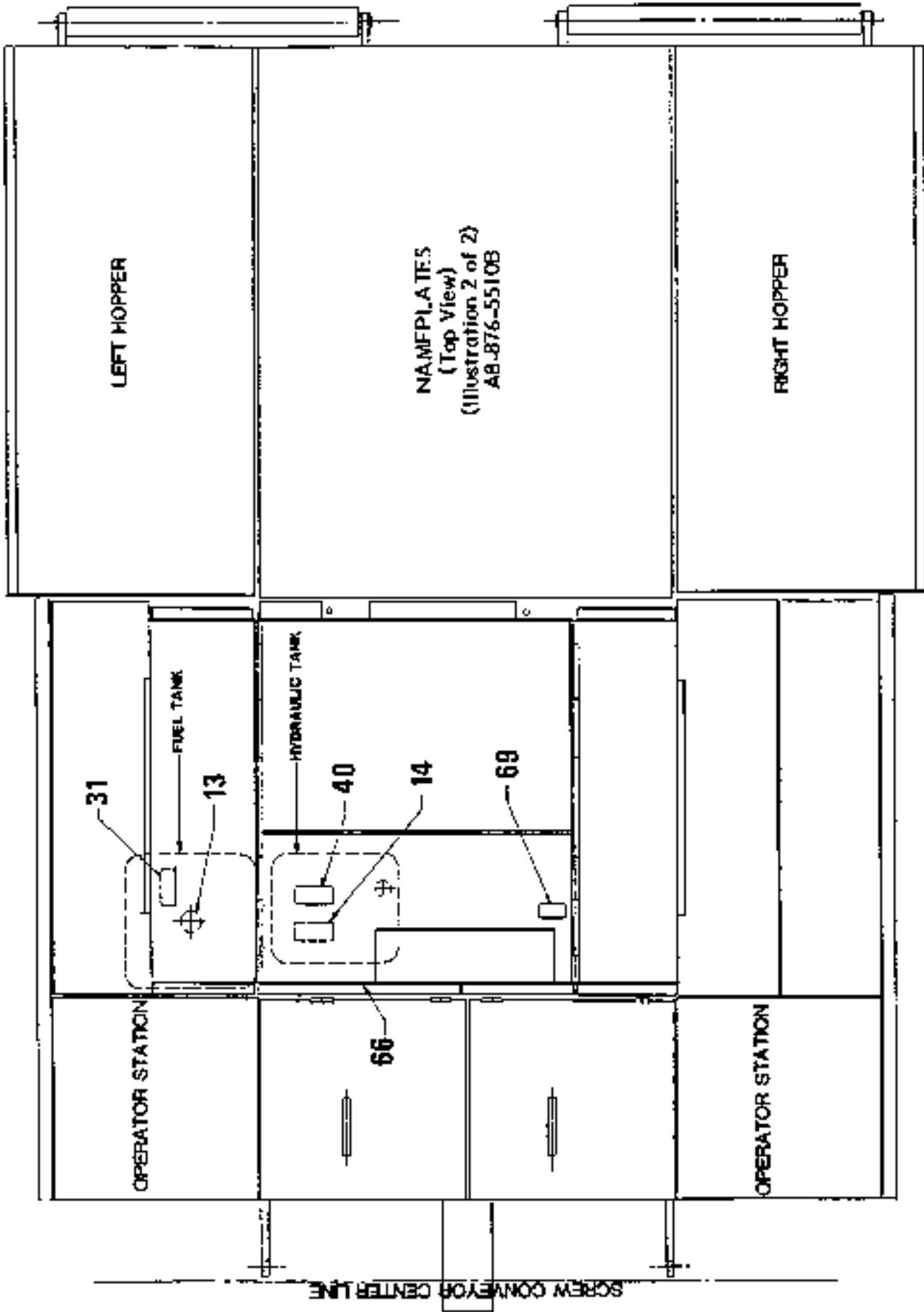

NAMEPLATES

A8-876-5510B

(Before Ordering, Consult Table of Contents to Verify Proper Bill of Material Number.)

REF.	PART NUMBER	QTY.	DESCRIPTION
Ref. #13 thru #76 Symbolized by NONE on Illustrations 1 & 2.			
	A2-46-1997	1	Nameplate, "PATENT PENDING PLATE"
	A-46-58	1	Nameplate, "MACHINE SERIAL NUMBER"
	26A77	3	#10 X 3/8" Drive Screw
	A-46-1998	1	Tag, Filter Notice
13	A-46-2320	1	Decal, "CAUTION - DIESEL FUEL ONLY"
14	A-46-2008	1	Decal, Hydraulic Tank Instructions
	C-46-1836	1	Decal, Lubrication
18	D-46-1836	1	Decal, Warranty Notice
25	RTC-92804-04	2	Decal, "WARNING - READ AND UNDERSTAND OPERATOR'S MANUAL BEFORE OPERATING OR SERVICING THIS MACHINE"
26	A-46-2337	1	Decal, "WARNING - VIBRATOR HYDRAULIC CONNECTIONS ON THE TRACTOR MUST BE LOOPED TOGETHER WHEN REMOVING THE SCREED TO PREVENT PUMP DAMAGE."
27	A8-46-2320	2	Decal, "WARNING - PINCH POINT AREA - KEEP CLEAR WHILE MACHINE IS IN OPERATION."
28	AC-46-2320	2	Decal, "WARNING - STAND CLEAR IF ENGINE IS RUNNING."
29	B-46-2320	1	Decal, "DANGER - STAND CLEAR IF ENGINE IS RUNNING."
30	AA-46-2320	2	Decal, "DANGER - STAND CLEAR IF ENGINE IS RUNNING."
31	RTC-92800-04	2	Decal, "CAUTION - NO SMOKING WITHIN 50 FEET DURING FUELING OR WASHDOWN."
32	RTC-92798-04	1	Decal, "CAUTION - CLEAN FUEL, LUBRICANTS AND HYDRAULIC OIL FROM WALKWAYS"
	AG-876-4648	1	Strap, Hopper Shipping
	26E29	2	1/2" x 1-1/2" Hex Head Cap Screw
	26A38	2	1/2" Lock Nut
	27L58	2	1/2" Lock Washer
40	A-46-2065	1	Decal, "HYDRAULIC OIL ONLY"
	50J03	2	Grip, Handle (For Screed Travel Support Levers)
48	B-46-2216	1	Chart, Lubrication
49	A-46-2216	1	Chart, Lubrication
50	A3-46-2242	1	Schematic, Electrical
51	A4-46-2218	1	Schematic, Hydraulic
52	A2-46-2219	1	Decal, Loading
60	A-46-2085	4	Decal, "LIFT HERE"
61	A-46-2290	2	Decal (Barber-Greene Bee With Hard Hat)
62	A1-46-2240	2	Decal, "BG220B"
63	G-46-2240	4	Stripe, Hopper & Tractor
64	A-46-2259	2	Decal, "BARBER-GREENE" (With Logo)

REF.	PART NUMBER	QTY.	DESCRIPTION
65	A-46-2263	2	Decal (Oil Level)
66	A-46-2252	1	Decal, "BARBER-GREENE" (With Logo) (Located on Rear of Tractor Unit)
69	C-46-2320	1	Decal, "CAUTION - DO NOT OPERATE IN TRAVEL SPEED RANGE ON GRADES IN EXCESS OF 6%. SET BRAKES BEFORE SHIFTING."
	27X87	1	Filter (Grade Control)
	16X52	3	Element, Hydraulic Filter
74	A-46-2290	2	Decal, "CAUTION WHEN AUTOMATIC GRADE CONTROL IS NOT IN USE PIN CYLINDER"
75	A-46-2253	1	Nameplate, "TRAVEL - PAVE - TRANS SHIFT"
76	26A76	2	#4 x 5/16" Drive Screw
	A-46-2256	1	Tag, Engine Oil Drain Notice
	A-46-2254	2	Decal "200 SERIES"
	A-46-1779	1	Indicator, Gate

NAMEPLATES
{Side & Rear View}
(Illustration 1 of 2)
A9-676-5510B

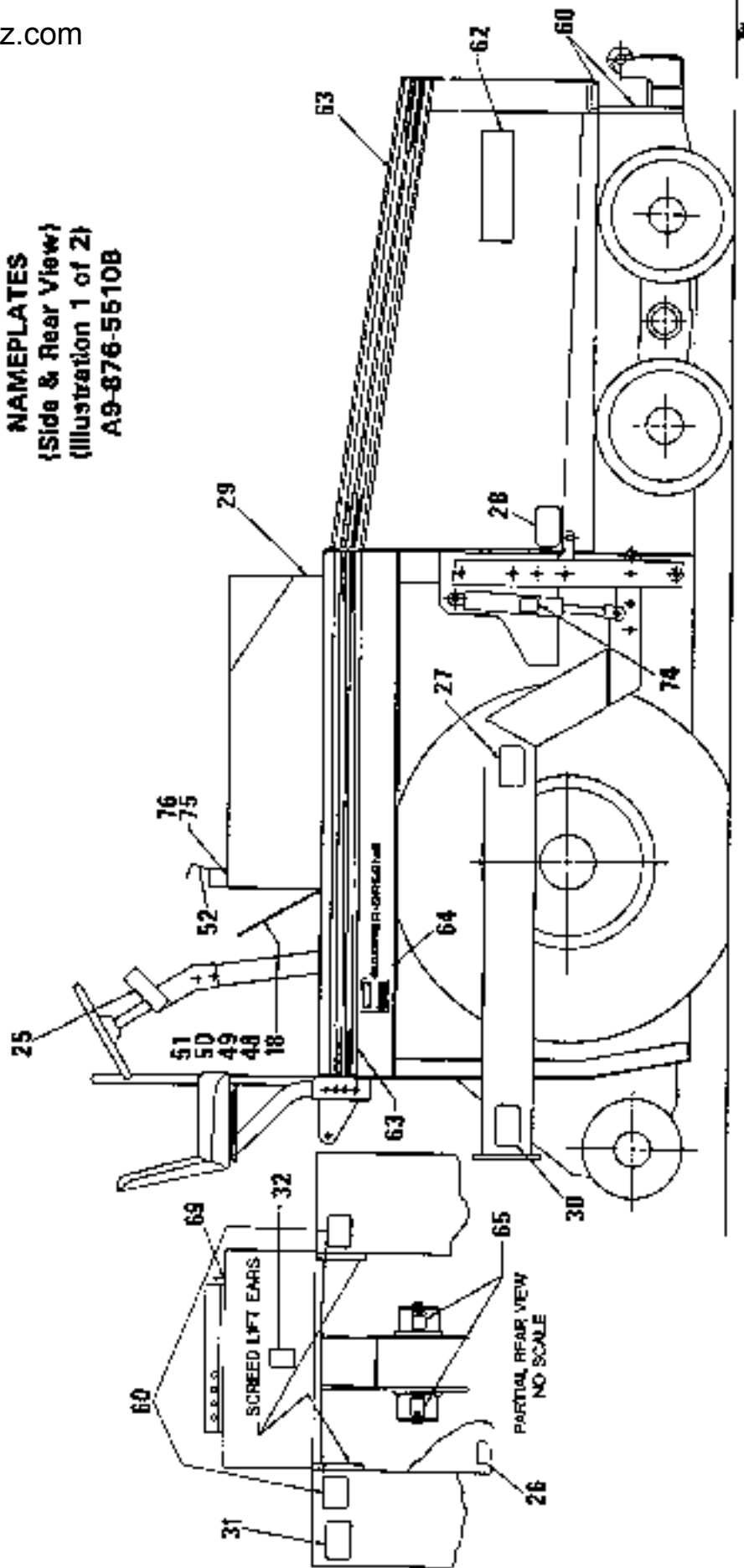

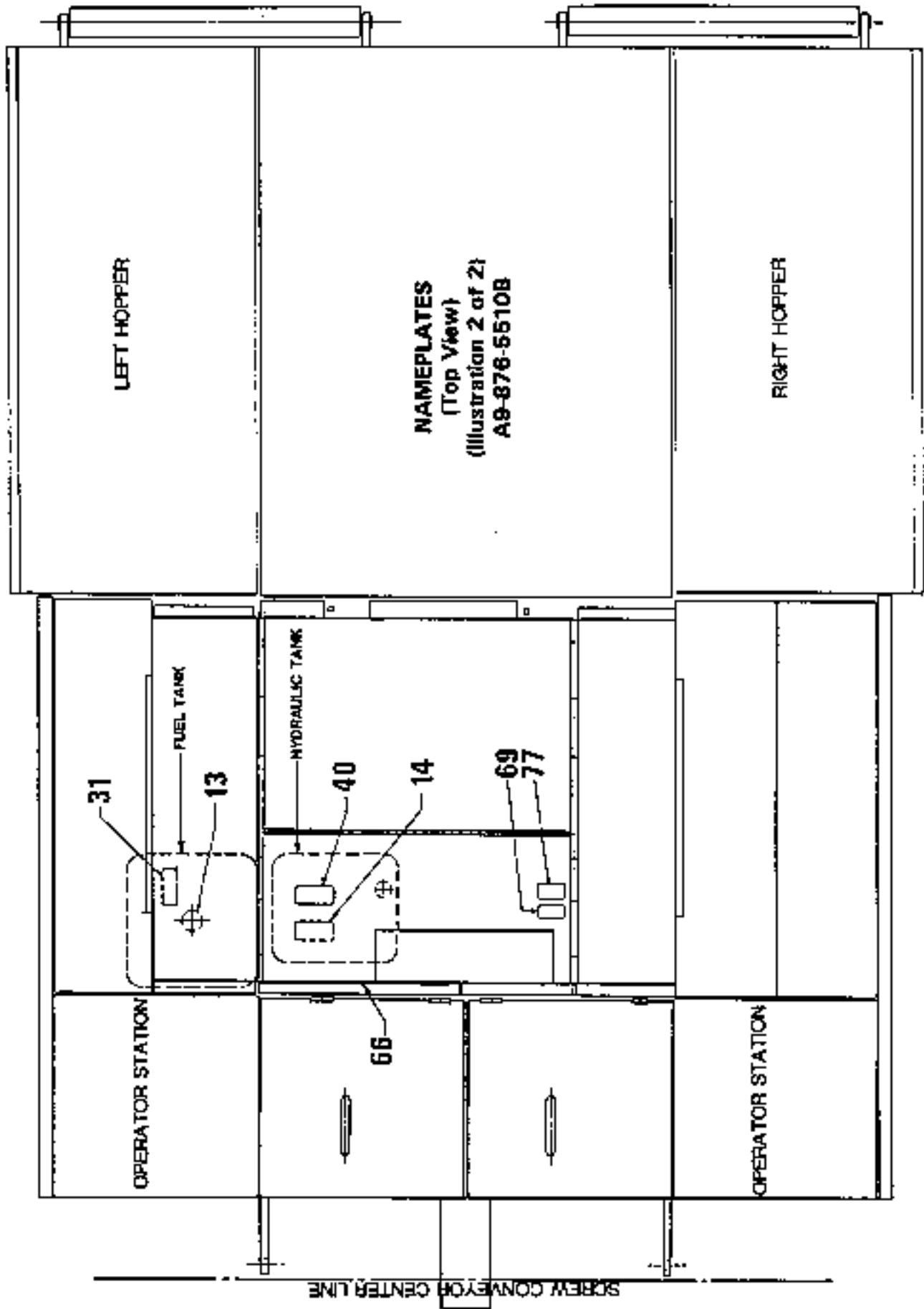

NAMEPLATES

A9-876-5510B

(Consult Table of Contents to Verify Proper Bill of Material Number.)

REF.	PART NUMBER	QTY.	DESCRIPTION
Ref. #13 thru #76 Symbolized by NONE on Illustrations 1 & 2.			
	9X-1877	1	Nameplate, "PRODUCT IDENTIFICATION NUMBER"
	11P12	4	#6 X 3/8" Drive Screw
	A-46-1998	1	Tag, Filter Notice
13	8C-4535	1	Decal, "CAUTION - DIESEL FUEL ONLY"
14	A-46-2008	1	Decal, Hydraulic Tank Instructions
	C-46-1836	1	Decal, Lubrication
18	D-46-1836	1	Decal, Warranty Notice
25	A-46-2373	2	Decal, "WARNING - READ AND UNDERSTAND OPERATOR'S MANUAL BEFORE OPERATING OR SERVICING THIS MACHINE"
26	A-46-2337	1	Decal, "WARNING - VIBRATOR HYDRAULIC CONNECTIONS ON THE TRACTOR MUST BE LOOPED TOGETHER WHEN REMOVING THE SCREED TO PREVENT PUMP DAMAGE."
27	AB-46-2320	2	Decal, "WARNING - PINCH POINT AREA - KEEP CLEAR WHILE MACHINE IS IN OPERATION."
28	AC-46-2320	2	Decal, "WARNING - STAND CLEAR IF ENGINE IS RUNNING."
29	B-46-2320	1	Decal, "DANGER - STAND CLEAR IF ENGINE IS RUNNING."
30	AA-46-2320	2	Decal, "DANGER - STAND CLEAR IF ENGINE IS RUNNING."
31	B-46-2337	2	Decal, "CAUTION - NO SMOKING WITHIN 50 FEET DURING FUELING OR WASHDOWN."
32	A-46-2361	1	Decal, "CAUTION - CLEAN FUEL, LUBRICANTS AND HYDRAULIC OIL FROM WALKWAYS"
	AG-876-4648	1	Strap, Hopper Shipping
	26E29	2	1/2" x 1-1/2" Hex Head Cap Screw
	26A38	2	1/2" Lock Nut
	27L58	2	1/2" Lock Washer
40	8C-4316	1	Decal, "HYDRAULIC OIL ONLY"
	50J03	2	Grip, Handle (For Screed Travel Support Levers)
48	B-46-2216	1	Chart, Lubrication
49	A-46-2216	1	Chart, Lubrication
50	A3-46-2242	1	Schematic, Electrical
51	A5-46-2218	1	Schematic, Hydraulic
52	A2-46-2219	1	Decal, Loading
60	7X-3229	4	Decal, "LIFT HERE"
61	A-46-2290	2	Decal (Barber-Greene Bee With Hard Hat)
62	A1-46-2240	2	Decal, "BG220B"
63	G-46-2240	4	Stripe, Hopper & Tractor
64	A-46-2259	2	Decal, "BARBER-GREENE" (With Logo)

REF.	PART NUMBER	QTY.	DESCRIPTION
65	A-46-2263	2	Decal (Oil Level)
66	A-46-2252	1	Decal, "BARBER-GREENE" (With Logo) (Located on Rear of Tractor Unit)
69	C-46-2320	1	Decal, "CAUTION - DO NOT OPERATE IN TRAVEL SPEED RANGE ON GRADES IN EXCESS OF 6%. SET BRAKES BEFORE SHIFTING."
	27X87	1	Filter (Grade Control)
	16X52	3	Element, Hydraulic Filter
74	A-46-2280	2	Decal, "CAUTION WHEN AUTOMATIC GRADE CONTROL IS NOT IN USE PIN CYLINDER"
75	A-46-2253	1	Nameplate, "TRAVEL - PAVE - TRANS SHIFT"
76	26A76	2	#4 x 5/16" Drive Screw
	A-46-2256	1	Tag, Engine Oil Drain Notice
	A-46-2254	2	Decal "200 SERIES"
	A-46-1779	1	Indicator, Gate
	A-46-2375	1	Decal "USE THE SERVICE FOOT BRAKE WHEN STOPPED TEMPORARILY. APPLY THE PARKING BRAKE FOR LONGER STOPS. DO NOT LEAVE THE OPERATOR'S SEAT WITHOUT APPLYING THE PARKING BRAKE."

STEERING GAUGE

C-876-5315B

(Consult Table of Contents to Verify Proper Bill of Material Number.)

REF.	PART NUMBER	QTY.	DESCRIPTION
	A-876-5317W	1	Support, Steering Gauge & Ski (Right Side)
	B-876-5317W	1	Support, Steering Gauge & Ski (Left Side)
	26E27	4	1/2" x 3.50" Hex Head Cap Screw
	F-876-1932W	1	Pin
	26C54	1	1/2" x 2" Hex Head Cap Screw
	27L81	1	1/2" Lock Washer
	HH-17-9	1	Washer, 9/16" I.D. x 7/8" O.D. x 12 Ga.
	27C95	1	1/2" Hex Nut
	A-876-1932W	1	Guide, Inner
	A-876-1933	1	Sleeve
	B-876-222W	1	Guide, Outer
	C-876-5317W	1	Rod
	11A54	1	Chain, 5/16" Coil Proof x 17.50"
	27C95	2	1/2" Hex Nut
	26B14	2	3/8" x 1.25" Thumb Screw

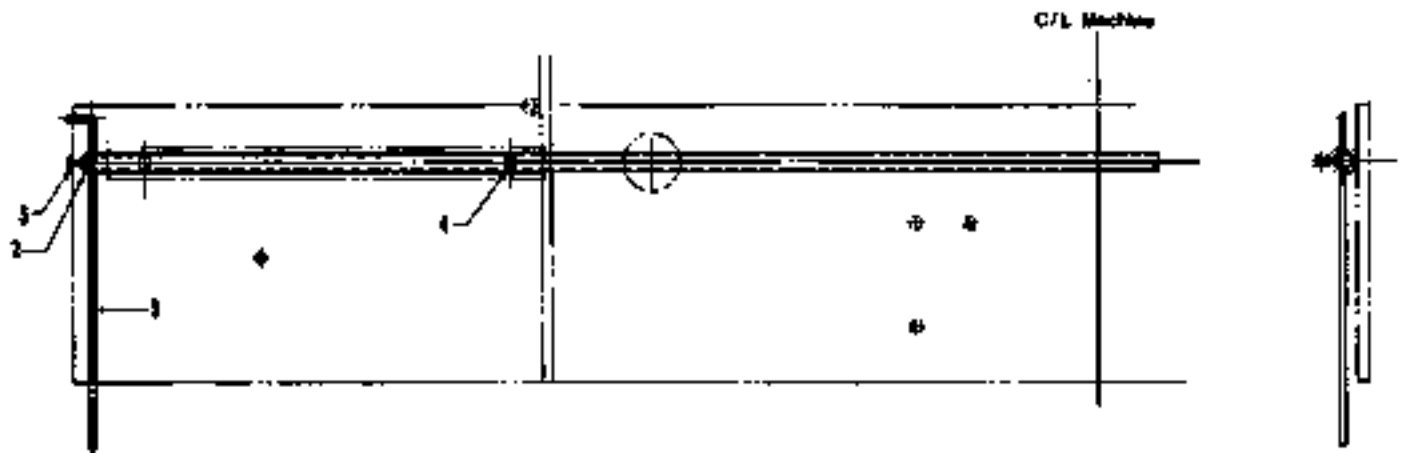

STEERING GAUGE

A-876-4825B

(Before Ordering, Consult Table of Contents to Verify Proper Bill of Material Number.)

REF.	PART NUMBER	QTY.	DESCRIPTION
2	A-876-4827W	1	Tube, Cross
3	C-876-4828	1	Rod
4	27G54	2	3/8" x 1" Hex Head Cap Screw
5	27H04	1	1/2" x 1" Hex Head Cap Screw

3/25/87 (1-2)

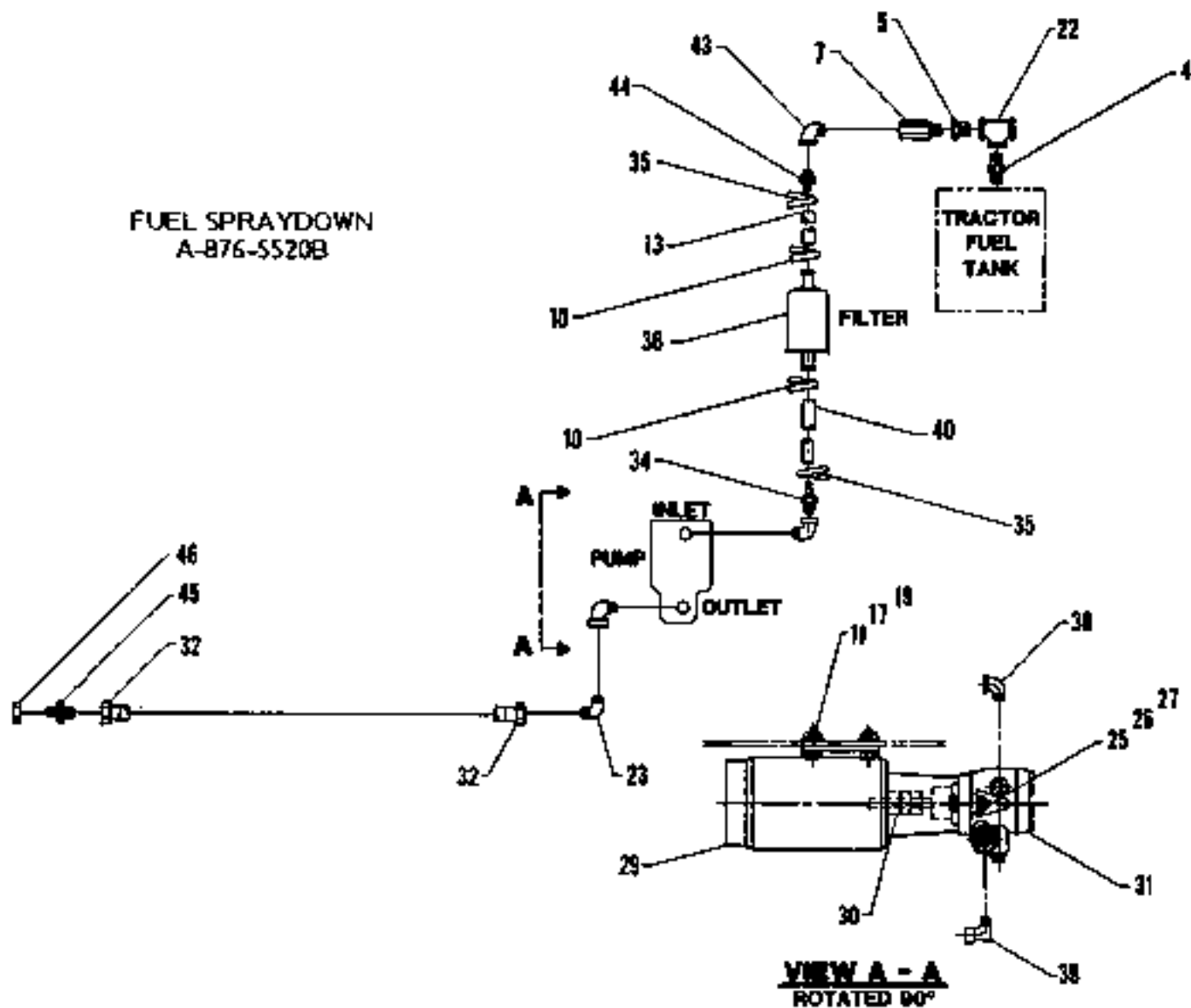

FUEL SPRAYDOWN

A-976-5520B

(Before Ordering, Consult Table of Contents to Verify Proper Bill of Material Number.)

REF.	PART NUMBER	QTY.	DESCRIPTION
Ref. #4 thru #46 Symbolized by NONE on Illustration.			
	11P81	3	Tie, Plastic
4	23K59	1	Nipple, 3/8" N.P.T. Pipe
5	23D29	1	Bushing, 3/8" x 1/4" N.P.T.
7	31P61	1	Valve, Check
10	20N41	2	Clamp, Hose
11	27L54	2	5/16" Cut Washer
13	a 50N79	1	Hose, 5/16" x 40"
17	23V67	2	5/16" x 1" Hex Head Cap Screw
19	14Z77	2	5/16" Lock Nut
22	23H50	1	Tee, 3/8" N.P.T.
23	23C20	1	Elbow, 90° - 1/4" Pipe to 3/8" Tube
25	13M81	2	3/8" x 1-3/4" Hex Head Cap Screw
26	27L78	2	3/8" Lock Washer
27	27C90	2	3/8" Hex Nut
29	15V11	1	Motor, D.C.
30	15W64	1	Coupling
31	31R56	1	Pump, Fuel (Consisting in part of the following indented items):
	31R56C1	1	. Strainer (6 G.P.H.)
	31R56C2	1	. Gasket, Cover
32	BD-80-484W	1	Hose, 1/4" I.D. x 77"
34	23M29	1	Coupling, 1/4" N.P.T. x 1/4" Hose
35	20N41	2	Clamp, Hose
36	13N74	1	Filter, Fuel
38	23C40	1	Elbow, 90° St. x 1/4" N.P.T.
39	23H52	1	Elbow, 90° St. - 1/8" Ma. x 1/4" N.P.T. Red. (Brass)
40	a 50N79	1	Hose, 5/16" x 2"
43	23C18	1	Elbow, 90° - 1/4" Tube x 1/4" N.P.T.F.
44	23D49	1	Connector, 1/4" Hose I.D. x 7/16"-20 45° Str. Thd.
45	12X17	1	Bulkhead, Union x 3/8" Tube (Body Only)
46	12T24	1	Cap, 3/8" Tube

a - IMPORTANT - Be sure to specify length when ordering.

FUEL SPRAYDOWN
AI-876-5520B

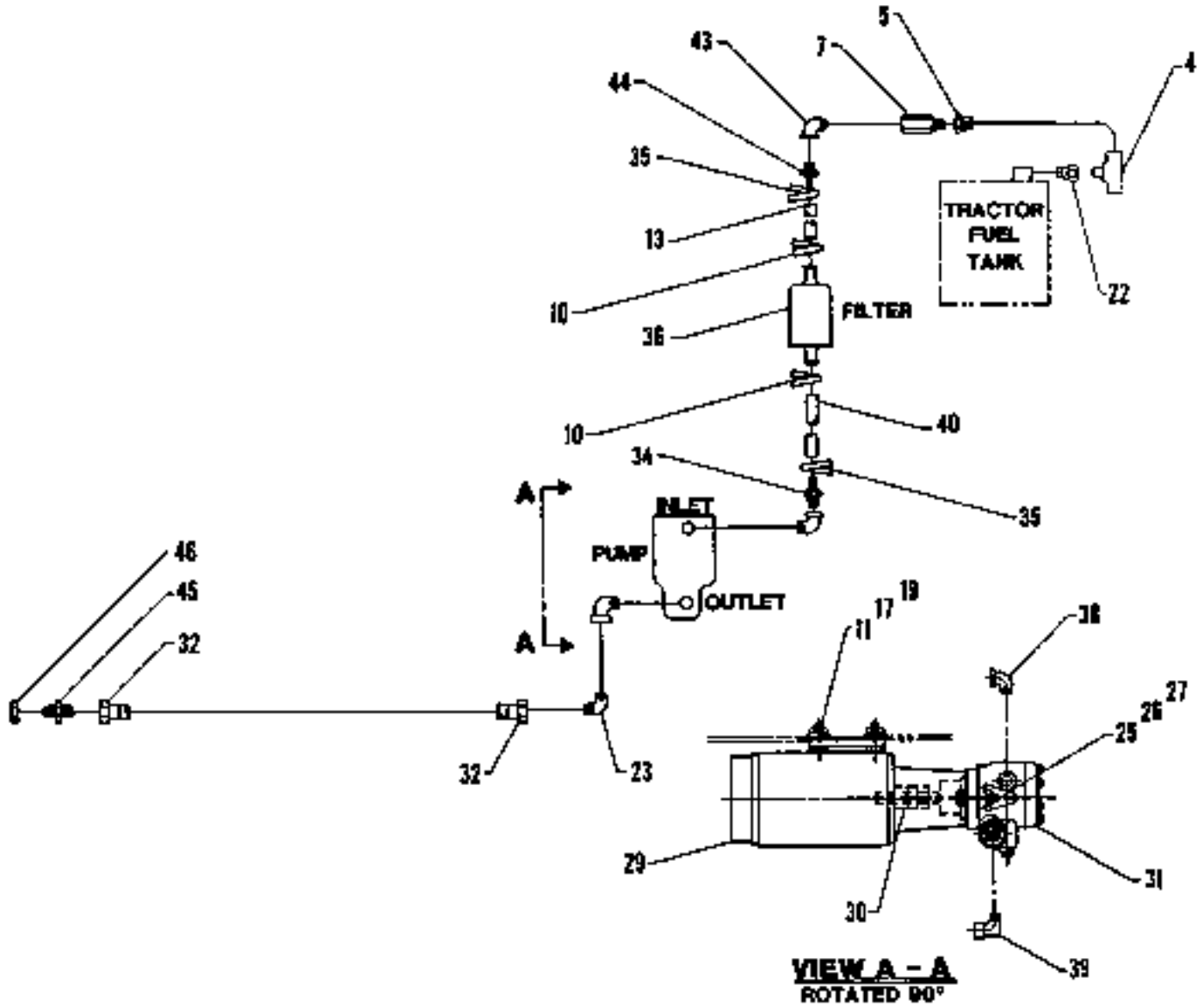

FUEL SPRAYDOWN

AI-876-5520B

(Before Ordering, Consult Table of Contents to Verify Proper Bill of Material Number.)

REF.	PART NUMBER	QTY.	DESCRIPTION
Ref. #4 thru #46 Symbolized by NONE on Illustration.			
	11P81	3	Tie, Plastic
4	32A05	1	Tee, 1/4" N.P.T. Male Branch
7	31P61	1	Valve, Check
10	20N41	2	Clamp, Hose
11	27L54	2	5/16" Cut Washer
13 a	50N79	1	Hose, 5/16" x 40"
17	23V67	2	5/16" x 1" Hex Head Cap Screw
19	14Z77	2	5/16" Lock Nut
22	23E23	1	Connector, 1/4" N.P.T. x 1/4" N.P.T. Swivel
23	23C20	1	Elbow, 90° - 1/4" Pipe to 3/8" Tube
25	13M81	2	3/8" x 1-3/4" Hex Head Cap Screw
26	27L78	2	3/8" Lock Washer
27	27C90	2	3/8" Hex Nut
29	15V11	1	Motor, D.C.
30	15W64	1	Coupling
31	31R56	1	Pump, Fuel (Consisting in part of the following indented items):
	31R56C1	1	. Strainer (6 G.P.H.)
	31R56C2	1	. Gasket, Cover
32	BD-80-484W	1	Hose, 1/4" I.D. x 77"
34	23M29	1	Coupling, 1/4" N.P.T. x 1/4" Hose
35	20N41	2	Clamp, Hose
36	13N74	1	Filter, Fuel
38	23C40	1	Elbow, 90° St. x 1/4" N.P.T.
39	23H52	1	Elbow, 90° St. - 1/8" Ma. x 1/4" N.P.T. Red. (Brass)
40 a	50N79	1	Hose, 5/16" x 2"
43	23C18	1	Elbow, 90° - 1/4" Tube x 1/4" N.P.T.F.
44	23D49	1	Connector, 1/4" Hose I.D. x 7/16"-20 45° Str. Thd.
45	12X17	1	Bulkhead, Union x 3/8" Tube (Body Only)
46	12T24	1	Cap, 3/8" Tube

a - IMPORTANT - Be sure to specify length when ordering.

TRACTOR MAIN FRAME

A2-876-5415B

(Before Ordering, Consult Table of Contents to Verify Proper Bill of Material Number.)

REF.	PART NUMBER	QTY.	DESCRIPTION
	A2-876-5417W	1	Main Frame, Tractor

TRACTOR MAIN FRAME

A3-876-5415B

(Before Ordering, Consult Table of Contents to Verify Proper Bill of Material Number.)

REF.	PART NUMBER	QTY.	DESCRIPTION
	A3-876-5417W	1	Main Frame, Tractor

TRACTOR MAIN FRAME

A4-876-5415B

(Before Ordering, Consult Table of Contents to Verify Proper Bill of Material Number.)

REF.	PART NUMBER	QTY.	DESCRIPTION
	A4-876-5417W	1	Main Frame, Tractor

**TRACTOR MAINFRAME EXTENSIONS
(For Wide Width Paving)
(BG-220B & BG-225B Pavers Only)**

A-876-5325B (1'-10" Mainframe Extension)
B-876-5325B (Mainframe Brace) (16' - 26')
C-876-5325B (1'-0" Mainframe Extension)

(Before Ordering, Consult Table of Contents to Verify Proper Bill of Material Number.)

<u>REF.</u>	<u>PART NUMBER</u>	<u>QTY.</u>	<u>DESCRIPTION</u>
<u>A-876-5325B ONLY</u>			
	A-876-5327W	1	Extension, Mainframe (1'-10")
	26C49	3	5/8" x 1.75" Hex Head Cap Screw
	27L84	3	5/8" Lock Washer
	27C98	3	5/8" Hex Nut
<u>B-876-5325B ONLY</u>			
	BA-876-5327W	2	Brace, Mainframe Extension (16' - 26')
	16R69	1	1" x 3.25" Hex Head Cap Screw
	27M05	1	1" Lock Washer
	27D05	1	1" Hex Nut
	13J37	8	1/2" x 1.75" Hex Head Cap Screw
	27L81	8	1/2" Lock Washer
	27L58	8	1/2" Cut Washer
	27C95	8	1/2" Hex Nut
	BB-876-5327W	2	Brace, Mainframe Extension (16' - 26')
	16R69	1	1" x 3.25" Hex Head Cap Screw
	27M05	1	1" Lock Washer
	27D05	1	1" Hex Nut
<u>C-876-5325B ONLY</u>			
	AA-876-5327W	1	Extension, Mainframe (1'-0")
	26C49	3	5/8" x 1.75" Hex Head Cap Screw
	27L84	3	5/8" Lock Washer
	27C98	3	5/8" Hex Nut

UMBRELLA WITH SUPPORT

D-876-1860B

(Before Ordering, Consult Table of Contents to Verify Proper Bill of Material Number.)

REF.	PART NUMBER	QTY.	DESCRIPTION
	15F10	1	Umbrella
	A-876-1863	2	Plate, Support
	26E25	6	5/16" x 3/4" Hex Head Cap Screw
	27L77	6	5/16" Lock Washer
	27C87	6	5/16" Hex Nut

UMBRELLA

F-876-1860B

(Before Ordering, Consult Table of Contents to Verify Proper Bill of Material Number.)

REF.	PART NUMBER	QTY.	DESCRIPTION
	15F10	1	Umbrella

UMBRELLA WITH SUPPORT

G-876-1860B

(Before Ordering, Consult Table of Contents to Verify Proper Bill of Material Number.)

REF.	PART NUMBER	QTY.	DESCRIPTION
	15F10	1	Umbrella
	AH-870-1962W	1	T-Handle
	27D14	1	3/8" Jam Nut

TOOLS & SPARES
(Tractor With Standard Duty Feeder)

A1-876-5515B

(Before Ordering, Consult Table of Contents to Verify Proper Bill of Material Number.)

REF.	PART NUMBER	QTY.	DESCRIPTION
	26597	2	Link, Attachment (Feeder Flight Chain)
	26596	2	Link, Connecting (Feeder Flight Chain)
	A-876-1927W	2	Paddle (For Automatic Feeder Controls)
	16X52	3	Element, Hydraulic Filter
	E-46-1491A	1	Hose Assembly, Spray
	CG-17-218	4	Shim, .50"
	CH-17-218	2	Shim, .25"

TOOLS & SPARES
(Tractor With Heavy Duty Feeder)

D-876-5515B

(Before Ordering, Consult Table of Contents to Verify Proper Bill of Material Number.)

REF.	PART NUMBER	QTY.	DESCRIPTION
	13M95	2	Link, Feeder Flight Chain (Roller Link Assembly) (Heavy Duty)
	13M96	2	Link, Feeder Flight Chain (Connecting) (Heavy Duty)
	14M42	2	Link, Feeder Flight Chain (Attachment Connecting) (Heavy Duty)
	A-876-1927W	2	Paddle (For Automatic Feeder Controls)
	16X52	3	Element, Hydraulic Filter
	E-46-1491A	1	Spray Hose Assembly
	CG-17-218	4	Shim, .50"
	CH-17-218	2	Shim, .25"

**TOOLS & SPARES
(Grade Control)**

B-876-5315B

(Before Ordering, Consult Table of Contents to Verify Proper Bill of Material Number.)

<u>REF.</u>	<u>PART NUMBER</u>	<u>QTY.</u>	<u>DESCRIPTION</u>
	27X87	1	Filter (Grade Control)

PLATFORMS

EZ-876-5300B

(Before Ordering, Consult Table of Contents to Verify Proper Bill of Material Number.)

REF.	PART NUMBER	QTY.	DESCRIPTION
	EC-876-5302W	1	Angle, Support
	26C72	2	1/2" x 1.50" Flat Head Cap Screw
	27L58	2	1/2" Cut Washer
	27L81	2	1/2" Lock Washer
	27C95	2	1/2" Hex Nut
	CC1-876-5302W	1	Panel, Housing (Rear)
	26C53	3	3/8" x 1" Hex Head Cap Screw
	27L78	3	3/8" Lock Washer
	27L56	3	3/8" Cut Washer
	PA-876-5302W	1	Frame, Housing Support
	26C53	8	3/8" x 1" Hex Head Cap Screw
	27C90	6	3/8" Hex Nut
	27L78	8	3/8" Lock Washer
	B1-876-5303	1	Cover, Hydraulic Tank
	RB-876-5302W	1	Support, Left Housing
	27K03	1	#10-24 x 2" Round Head Machine Screw
	26C53	2	3/8" x 1" Hex Head Cap Screw
	27L78	2	3/8" Lock Washer
	27L56	2	3/8" Cut Washer
	14B32	4	Latch, Draw
	27J97	23	#10-24 x .62" Round Head Machine Screw
	27C79	23	#10-24 Nut
	27L99	23	#10 Lock Washer
	AA-876-5302W	1	Cover (Left)
	RA-876-5302W	1	Cover (Right)
	GC-876-5303	1	Pin, Pivot - 1/2"
	FF-876-5304	1	Pin, Pivot - 1/2"
	27D63	4	Pin, Cotter - 3/16" x 1.25"
	29L46	3	Cylinder, Gas Spring
	27L71	7	#10 Cut Washer
	14Z77	6	5/16" Lock Nut
	27L54	6	5/16" Cut Washer
	CB-876-5302W	1	Support, Rear Deck
	26C72	2	1/2" x 1.50" Flat Head Cap Screw
	27L58	2	1/2" Cut Washer
	27L81	2	1/2" Lock Washer
	27C95	2	1/2" Hex Nut
	DC1-876-5302W	1	Plate, Deck (Left)
	12T80	1	Grommet
	RC-876-5302W	1	Cover, Deck (Right)
	CA1-876-5302W	1	Cover, Deck (Right) (Tool Box)
	KA-876-5303	1	Cover, Deck (Left)
	26C53	13	3/8" x 1" Hex Head Cap Screw
	27L56	13	3/8" Cut Washer
	27L78	13	3/8" Lock Washer

REF.	PART NUMBER	QTY.	DESCRIPTION
	27C90	13	3/8" Hex Nut
	GA-876-5303	1	Cover, Frame (Rear)
	26C53	4	3/8" x 1" Hex Head Cap Screw
	27L78	4	3/8" Lock Washer
	KC-876-5303	1	Cover, Frame (Rear)
	GB-876-5303	2	Handrail
	26E85	8	1/2" x 2.50" Hex Head Cap Screw
	27L81	8	1/2" Lock Washer
	27C95	8	1/2" Hex Nut
	A-876-5304	1	Plate, Cover (Left)
	13J30	2	3/8" x .75" Hex Head Cap Screw
	27L78	2	3/8" Lock Washer
	27C90	2	3/8" Hex Nut
	AI-876-5303	1	Support, Electrical Box
	26C53	5	3/8" x 1" Hex Head Cap Screw
	27L78	5	3/8" Lock Washer
	27C90	5	3/8" Hex Nut
	28T48	1	Support, Lid
	27K01	1	#10-24 x 1" Round Head Machine Screw
	27N31	2	#10-24 x .50" Flat Head Machine Screw
	27L99	2	#10 Lock Washer
	27C79	2	#10-24 Hex Nut
	D-876-5304	1	Plate, Rear Cover
	26C53	2	3/8" x 1" Hex Head Cap Screw
	27L56	2	3/8" Cut Washer
	27L78	2	3/8" Lock Washer
	SA-876-5302W	1	Handrail (Left Side)
	SB-876-5302W	1	Handrail (Right Side)
	26C91	4	5/16" x .75" Self Tapping Screw
	28W93	4	3/8" x 1" Thumb Screw

PLATFORMS

E3-876-5300B

(Before Ordering, Consult Table of Contents to Verify Proper Bill of Material Number.)

REF.	PART NUMBER	QTY.	DESCRIPTION
	EC-876-5302W	1	Angle, Support
	26C72	2	1/2" x 1.50" Flat Head Cap Screw
	27L58	2	1/2" Cut Washer
	27L81	2	1/2" Lock Washer
	27C95	2	1/2" Hex Nut
	ZA-876-5302W	1	Panel, Housing (Rear)
	26C53	3	3/8" x 1" Hex Head Cap Screw
	27L78	3	3/8" Lock Washer
	27L56	3	3/8" Cut Washer
	FA-876-5502W	1	Frame, Housing Support
	26C53	8	3/8" x 1" Hex Head Cap Screw
	27C90	6	3/8" Hex Nut
	27L78	8	3/8" Lock Washer
	ZD-876-5302W	1	Cover, Hydraulic Tank
	27K03	1	#10-24 x 2" Round Head Machine Screw
	26C53	2	3/8" x 1" Hex Head Cap Screw
	27L78	2	3/8" Lock Washer
	27L56	2	3/8" Cut Washer
	14B32	4	Latch, Draw
	27J97	20	#10-24 x .62" Round Head Machine Screw
	27C79	17	#10-24 Nut
	27L99	20	#10 Lock Washer
	AA1-876-5302W	1	Cover (Left)
	GA-876-5502W	1	Cover (Right)
	GC1-876-5303	1	Pin, Pivot - 1/2"
	GG-876-5503	1	Pin, Pivot - 1/2"
	50E79	4	Pin, Roll - 3/16" x .75"
	28L46	3	Cylinder, Gas Spring
	27L71	7	#10 Cut Washer
	14Z77	6	5/16" Lock Nut
	27L54	6	5/16" Cut Washer
	CB-876-5302W	1	Support, Rear Deck
	26C72	2	1/2" x 1.50" Flat Head Cap Screw
	27L58	2	1/2" Cut Washer
	27L81	2	1/2" Lock Washer
	27C95	2	1/2" Hex Nut
	GC-876-5502W	1	Plate, Deck (Left)
	12T80	1	Grammet
	HA-876-5502W	1	Cover, Deck (Right)
	CAZ-876-5302W	1	Cover, Deck (Right) (Tool Box)
	KA-876-5303	1	Cover, Deck (Left) (Tool Box)
	26C53	13	3/8" x 1" Hex Head Cap Screw
	27L56	13	3/8" Cut Washer
	27L78	13	3/8" Lock Washer
	27C90	13	3/8" Hex Nut

REF.	PART NUMBER	QTY.	DESCRIPTION
	GA-876-5303	1	Cover, Frame (Rear)
	26C53	4	3/8" x 1" Hex Head Cap Screw
	27L78	4	3/8" Lock Washer
	KC-876-5303	1	Cover, Frame (Rear)
	GB-876-5303	2	Handrail
	26E85	8	1/2" x 2.50" Hex Head Cap Screw
	27L81	8	1/2" Lock Washer
	27C95	8	1/2" Hex Nut
	A-876-5304	1	Plate, Cover (Left)
	13J30	2	3/8" x .75" Hex Head Cap Screw
	27L78	2	3/8" Lock Washer
	27C90	2	3/8" Hex Nut
	AI-876-5303	1	Support, Electrical Box
	26C53	5	3/8" x 1" Hex Head Cap Screw
	27L78	5	3/8" Lock Washer
	27C90	5	3/8" Hex Nut
	BB-876-5502WL	1	Support, Lid
	BB-876-5502WR	1	Support, Lid
	27K01	1	#10-24 x 1" Round Head Machine Screw
	27N31	2	#10-24 x .50" Flat Head Machine Screw
	27L99	2	#10 Lock Washer
	27C79	2	#10-24 Hex Nut
	D-876-5304	1	Plate, Rear Cover
	26C53	2	3/8" x 1" Hex Head Cap Screw
	27L56	2	3/8" Cut Washer
	27L78	2	3/8" Lock Washer
	5A-876-5302W	1	Handrail (Left Side)
	5B-876-5302W	1	Handrail (Right Side)
	26C91	4	5/16" x .75" Self Tapping Screw
	28W93	4	3/8" x 1" Thumb Screw

FENDERS

A-876-5500B

(Before Ordering, Consult Table of Contents to Verify Proper Bill of Material Number.)

<u>REF.</u>	<u>PART NUMBER</u>	<u>QTY.</u>	<u>DESCRIPTION</u>
	A-876-5503	2	Fender
	26C53	6	3/8" x 1.00" Hex Head Cap Screw
	27C90	6	3/8" Nut
	27L78	6	3/8" Lock Washer

SECTION 12

BG-220B Asphalt Paver

COMPONENT BREAKDOWNS

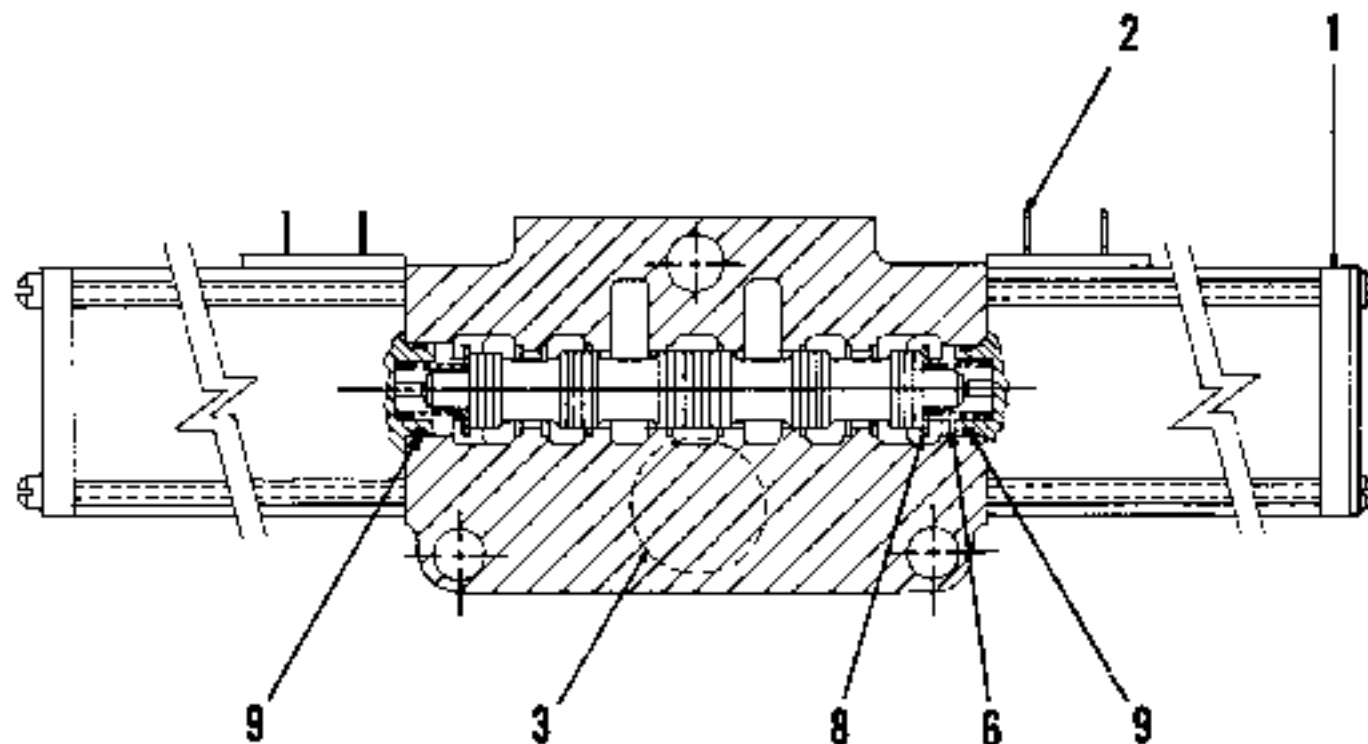

SBS VALVE

15K55

(From Tractor Hydraulics Bill of Material)

(Before Ordering, Consult Table of Contents to Verify Proper Bill of Material Number.)

REF.	PART NUMBER	QTY.	DESCRIPTION
	15K55C1	1	Valve (Screed Lift)
	15K55C2	1	Valve (Hopper Lift)
	15K55C3	1	Kit, Stacking

The following items are common to each valve sections:

1	15K55C4	2	Guide Tube & Case Assembly
2	14K82C1	2	Coil, Solenoid
3	15K55C5	1	O-Ring
6	15K55C6	2	Spring
8	15K55C7	2	Washer
9	50E78	2	O-Ring

Note: Only normally serviced items are listed.

Parts not normally stocked by Barber-Greene are subject to Vendor Minimum.

3/25/87

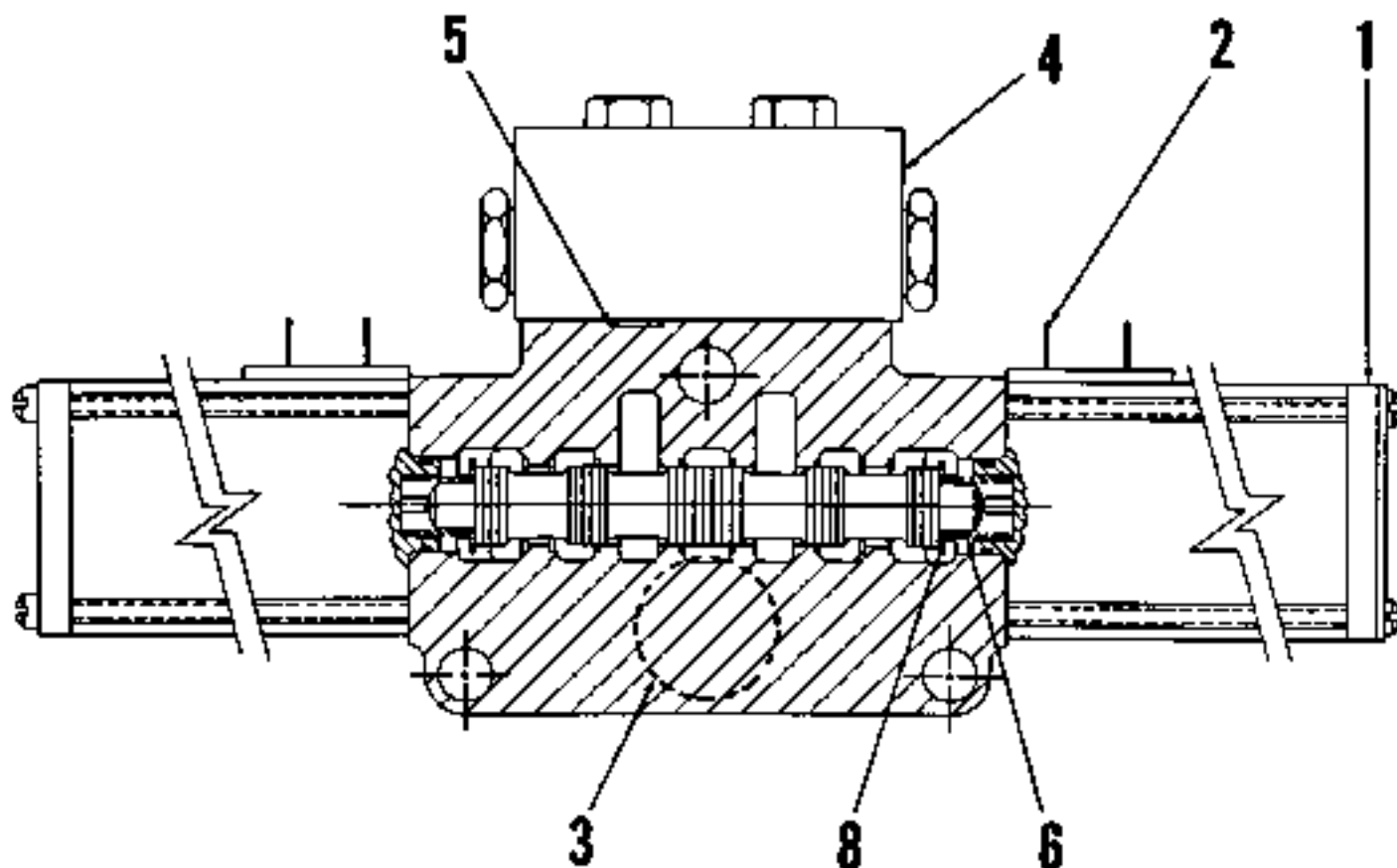

SOLENOID VALVE

26N60

(From Truck Hitch Bill of Material)

(Before Ordering, Consult Table of Contents to Verify Proper Bill of Material Number.)

REF.	PART NUMBER	QTY.	DESCRIPTION
1		2	Guide Tube & Case Assembly
2	14KB2C1	2	Coil, Solenoid
3	15K55C5	1	O-Ring
4	15W24C2	1	Double Cylinder Lock Valve Assembly
5	50E78	2	O-Ring
6	15K55C6	2	Spring
8	15K55C7	2	Washer

3/25/87

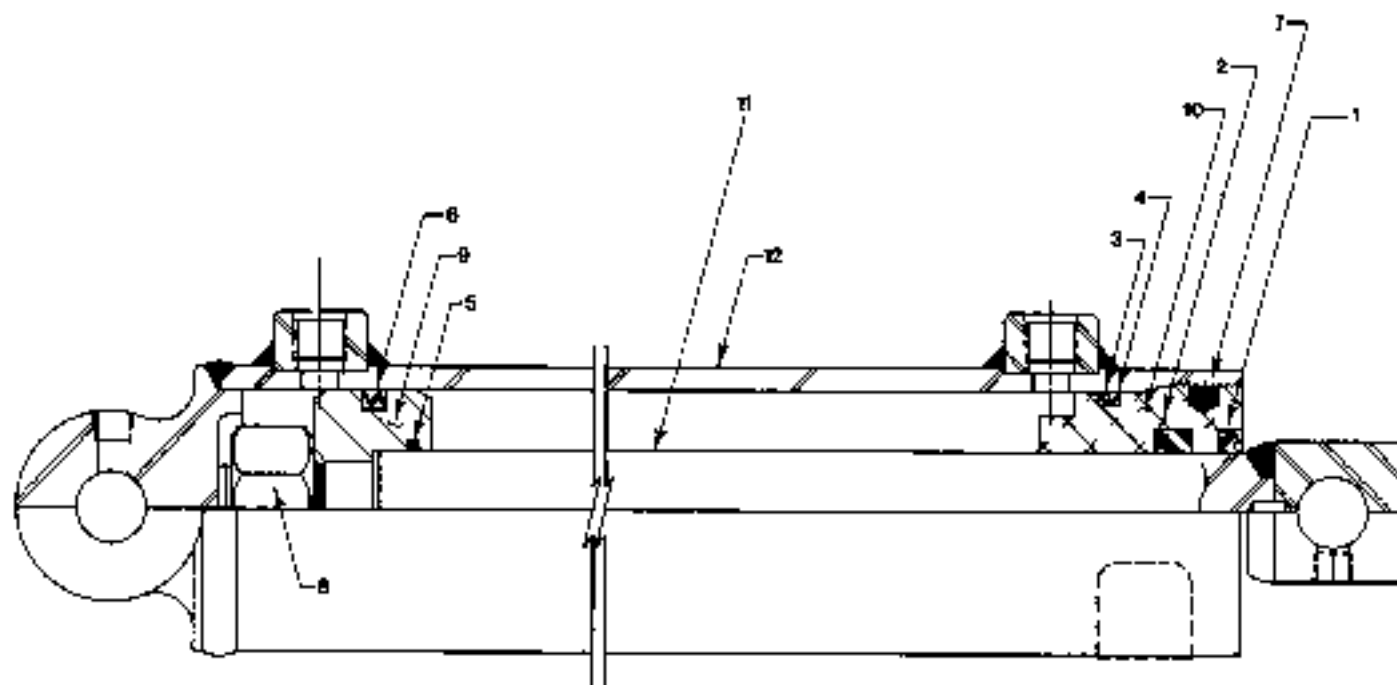

**HYDRAULIC CYLINDER
(Hopper)**

27V85

(From Tractor Hydraulics Bill of Material)

(Before Ordering, Consult Table of Contents to Verify Proper Bill of Material Number.)

REF.	PART NUMBER	QTY.	DESCRIPTION
	27V85C1	1	Kit, Seal (Consisting of the following indented items):
1		1	. Wiper, Lip Type
2		1	. U-Ring
3		1	. O-Ring
4		1	. Back-Up
5		1	. O-Ring
6		1	. T-Ring
7		1	. Plug, Nylon
8		1	Nut
9		1	Piston
10		1	Retainer
11		1	Rod Assembly
12		1	Tube Assembly

Parts not normally stocked by Barber-Greene are subject to Vendor Minimum.

3/25/87

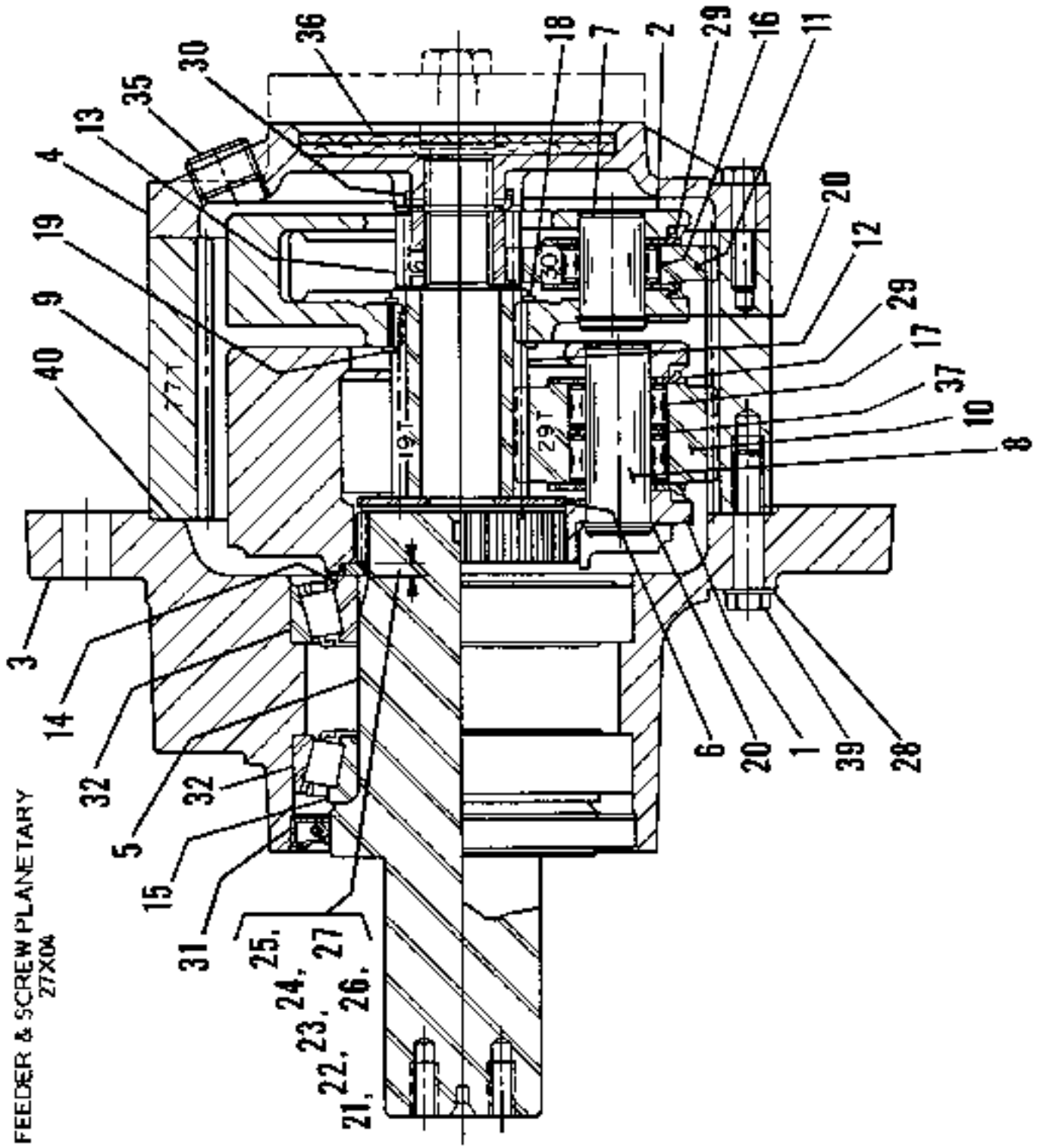

FEEDER & SCREW PLANETARY

27X04

(From Feeder & Screw Planetary, Sprocket & Chain Bill of Material)
 (Before Ordering, Consult Table of Contents to Verify Proper Bill of Material Number.)

REF.	PART NUMBER	QTY.	DESCRIPTION
1		1	Carrier, Planet
2		1	Carrier, Planet
3		1	Hub
4		1	Cover
5		1	Shaft, Output
6		1	Washer, Thrust
7		3	Shaft, Pinion
8		3	Shaft, Pinion
9		1	Gear, Ring
10	27X04C1	3	Gear, Planet
11	27X04C2	3	Gear, Planet
12	27X04C3	1	Gear, Sun
13	27X04C4	1	Gear, Sun
14	27X04C5	1	Cone, Bearing
15	27X04C6	1	Cone, Bearing
16	27X04C7	51	Bearing
17	27X04C8	102	Bearing
18		1	Ring, Retaining
19		1	Ring, Retaining
20		6	Ring, Retaining
21		1	Ring, Retaining
22		1	Ring, Retaining
23		1	Ring, Retaining
24		1	Ring, Retaining
25		1	Ring, Retaining
26		1	Ring, Retaining
27		1	Ring, Retaining
28		6	Washer, Flat
29		12	Washer, Thrust
30		2	Washer, Thrust
31	27X04C9	1	Seal, Oil
32	27X04C10	2	Cup, Bearing
		1	Plug, Pipe
		1	Plug, Pipe
35		1	Plug, Magnetic
36		1	Plug, Shipping
37		3	Ring, Sep.
		8	Hex Head Bolt
39		6	Hex Head Bolt
40		1	Comp., Sealing

NOTE: Parts not normally stocked by Barber-Greene are subject to Vendor Minimum.

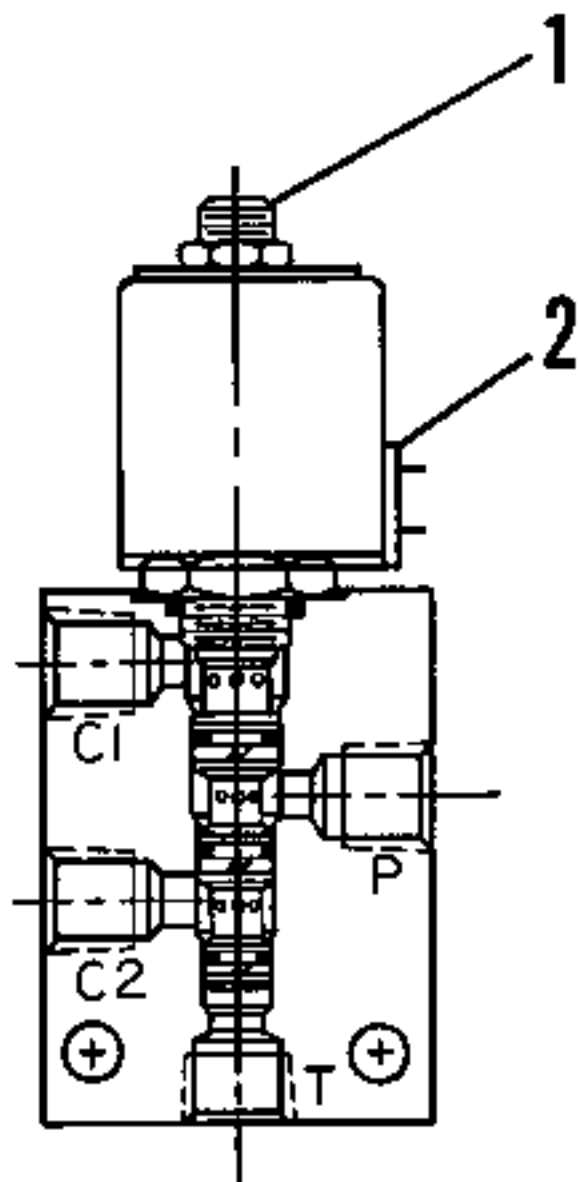

SOLENOID VALVE

27X16

(From Tractor Hydraulics Bill of Material)

(Before Ordering, Consult Table of Contents to Verify Proper Bill of Material Number.)

REF.	PART NUMBER	QTY.	DESCRIPTION
1	27X16C2	1	Cartridge
2	27X16C1	1	Coil

NOTE: Only normally serviced items are listed.
Parts not normally stocked by Barber-Greene are subject to vendor minimum.

3/25/87

HYDRAULIC SBS PUMP
27X33

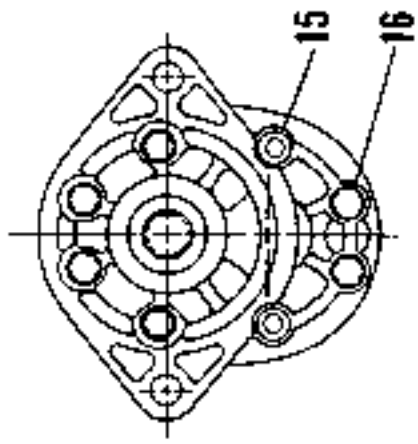
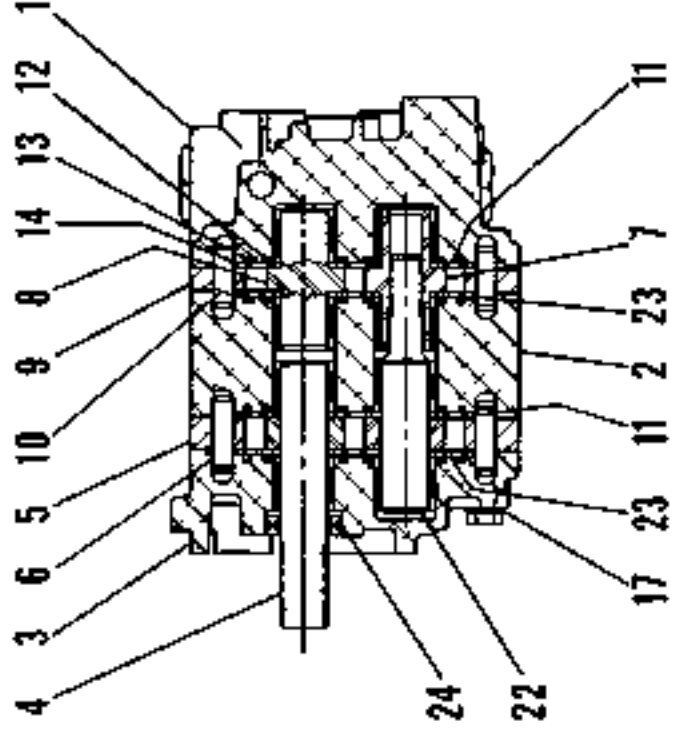
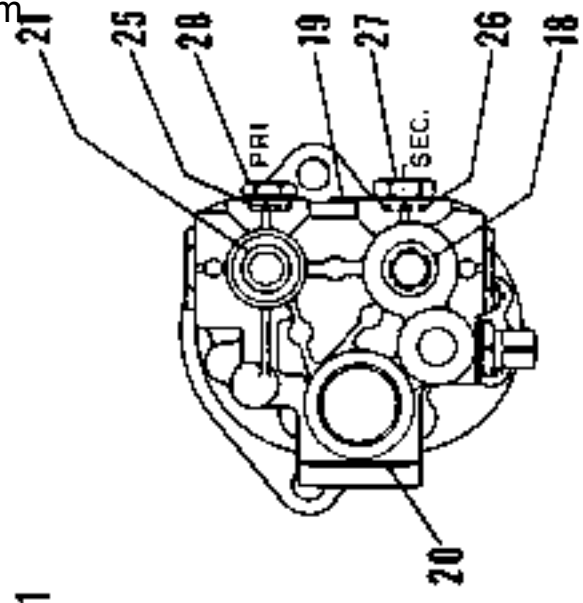

HYDRAULIC SBS PUMP

27X33

(From Tractor Hydraulics Bill of Material)
 (Before Ordering, Consult Table of Contents to Verify Proper Bill of Material Number.)

REF.	PART NUMBER	QTY.	DESCRIPTION
1		1	Cover Assembly, Pump (Consisting of the following indented items):
		1	• Cover Assembly, R.V. Tube & Seat
		1	• Piston
		1	• Spring, Compression
		2	• O-Ring
		2	• Plug
		1	• Poppet
		1	• Spring, Guide
		1	• O-Ring
		1	• Plug
		1	• Gasket
		1	• Valve, Cap
		2	• 1/2"-20 x 1.38" Set Screw
		2	• Spring, Compression
		1	• 1/2"-20 x 1.75" Set Screw
		1	• Spring, Compression
		2	• Bearing, Needle
		1	• Disc, Orifice
2		1	Plate Assembly, Bearing (Consisting of the following indented items):
		1	• Plate, Bearing
		4	• Bearing, Needle
3		1	Body Assembly, L.H. - YC (Consisting of the following indented items):
		1	• Body L.H., Pump Yd. & K
		2	• Bearing, Needle
4	27X33C7	1	Shaft & Gear Assembly, Drive (Consisting of the following indented items):
		1	• Shaft, Drive
		1	• Gear
5	27X33C8	1	Plate, Gear
6	27X33C9	2	Dowel
7	27X33C10	1	Gear, Drive
8	27X33C11	1	Shaft, Idler
9	27X33C12	1	Plate, Gear
10	27X33C13	2	Dowel
11	27X33C4	2	Plate, Wear
12	27X33C1	4	Seal, Pre-Load
13	27X33C2	4	Seal, Load
14	27X33C3	4	Seal, Ring
15		2	3/8" x 5" Hex Socket Head Cap Screw
16		8	3/8" x 5" Hex Head Cap Screw
17		8	Washer

3/25/87

(Continued)

REF.	PART NUMBER	QTY.	DESCRIPTION
18			Caplug
19			Caplug
20			Caplug
21			Caplug
22	27X33C14	1	Shaft & Gear Assembly, Drive (Consisting of the following indented items):
			. Shaft, Drive
			. Gear
23	27X33C5	2	Plate, Wear
24	27X33C6		Seal, Oil
25	27X33C15		O-Ring
26	27X33C16		O-Ring
27			Plug
28			Plug

a - Note: Order Quantities as Required.

NOTE: Parts not normally stocked by Barber-Greene are subject to Vendor Minimum.

DIFFERENTIAL HEAD ASSEMBLY
27X64

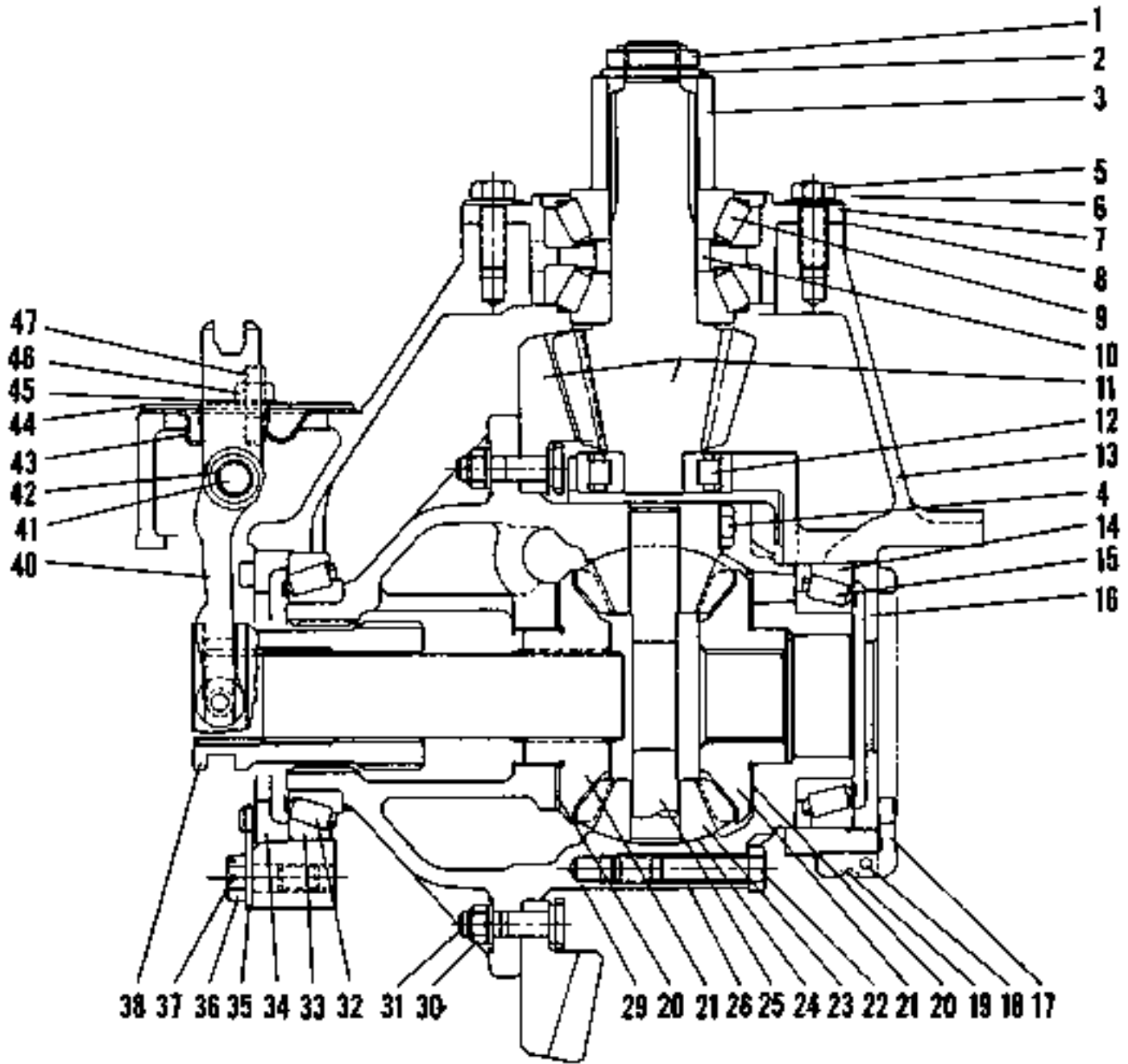

DIFFERENTIAL HEAD ASSEMBLY

27X64

(From Drive Axle Assembly Bill of Material)
 (Before Ordering, Consult Table of Contents to Verify Proper Bill of Material Number.)

REF.	PART NUMBER	QTY.	DESCRIPTION
1		1	End Nut, Pinion Shaft
2		1	Washer
3		1	Spacer, Pinion Shaft (Shipping Only)
4		4	Cap Screw, Diff. Case
5		6	Cap Screw
6		6	Lock Washer
7		1	Bearing Cage & Cups Assembly, Pinion
8		a	Shim, .003" Thick
8		a	Shim, .005" Thick
8		a	Shim, .010" Thick
8		a	Shim, .020" Thick
8		a	Shim, .030" Thick
9		1	Cone & Roller Assembly
10		1	Spacer, Pinion Shaft Bearing (Variable to Suit)
11		1	Pinion & Gear Matched Set
12	27X64C4	1	Bearing, Inner Pinion
13		1	Carrier & Caps Assembly, Differential
14	27X64C2	1	Cup, Bearing (R.H.)
15	27X64C3	1	Cone & Roller Assembly, Bearing
16		1	Adjuster, Differential Bearing (R.H.)
17		1	Adjuster Lock, Differential Bearing (R.H.)
18		1	Cotter Pin
19		1	Lock Wire
20	b	2	Thrust Washer, Differential Side Gear
21	b	2	Gear, Differential Side
22		8	Cap Screw, Differential Case
23	b	4	Pinion, Differential Side
24	b	4	Thrust Washer, Differential Side Pinion
25	b	1	Spider, Differential
26		1	Case, Differential - Plain Half
29		1	Case, Differential - Flanged Half
30		16	Lock Nut
31		16	Bolt
32	27X64C5	1	Cone & Roller Assembly, Bearing (L.H.)
33	27X64C6	1	Cup, Bearing (L.H.)
34		1	Adjuster, Differential Bearing (L.H.)
35		1	Adjuster Lock, Differential Bearing (L.H.)
36		a	Capscrew
37		1	Lock Wire
38		1	Clutch Gear, Sliding Lockout
40		1	Fork & Pin Assembly, Shift
41		1	Shaft, Shift Fork
42		1	Plug, Expansion (Upper & Lower)
43		1	Seal & Spring Assembly, Shift Fork

3/25/87

(Continued)

REF.	PART NUMBER	QTY.	DESCRIPTION
44		1	Opening Cover, Shift Fork (Shipping Only)
45		2	Washer
46		2	Lock Nut
47		2	Stud

a - NOTE: Order Quantities as Required.

b - These Parts Contained in Wheel Differential Kit Part Number 27X64CI.

NOTE: Parts not normally stocked by Barber-Greene, are subject to Vendor Minimum.

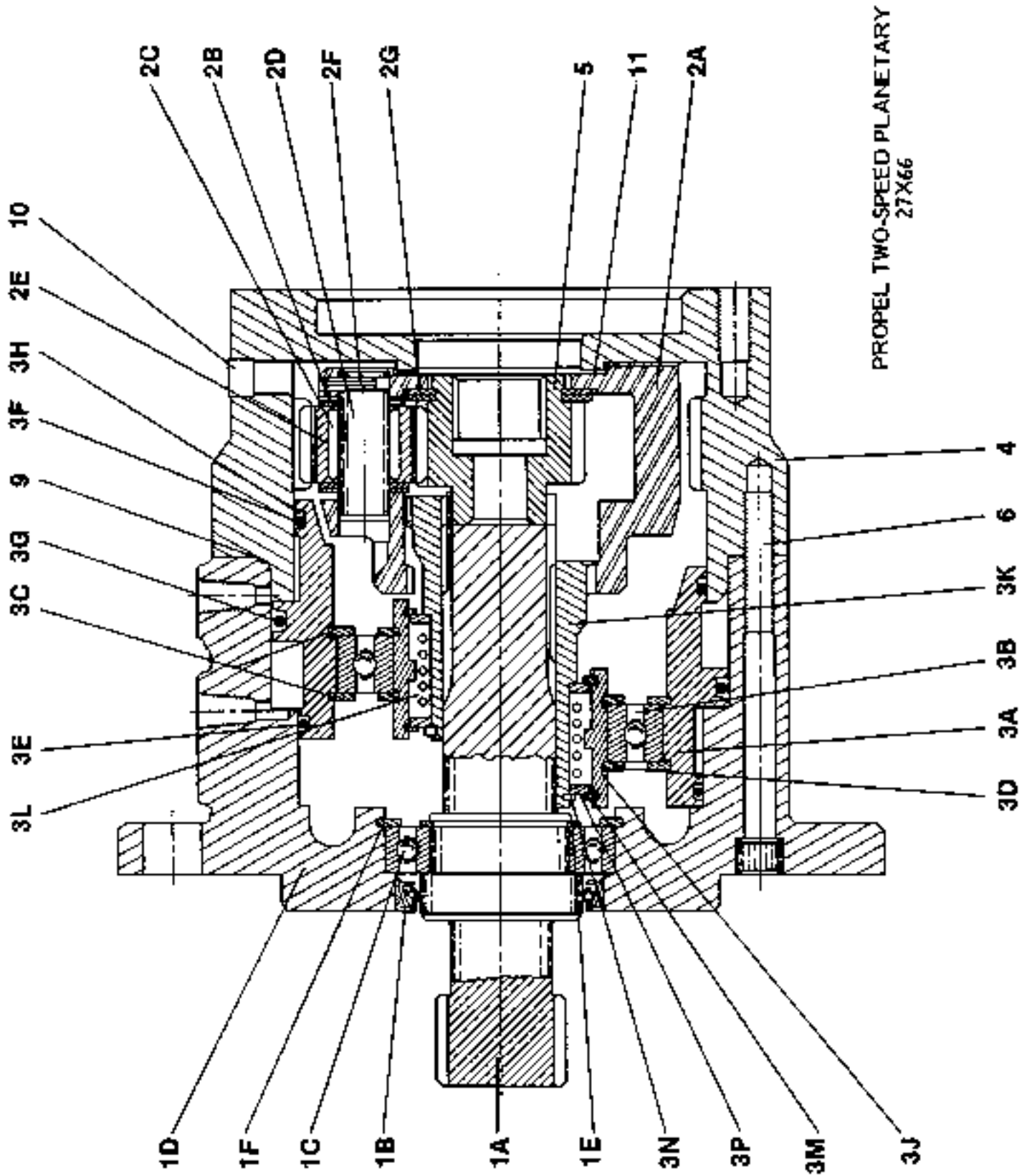

3/25/87

PROPEL TWO-SPEED PLANETARY

27X66

(From Drive Axle Assembly Bill of Material)
 (Before Ordering, Consult Table of Contents to Verify Proper Bill of Material Number.)

REF.	PART NUMBER	QTY.	DESCRIPTION
		1	Hub-Spindle Sub-Assembly (Consisting of the following indented items):
1A		1	. Shaft, Output
1B	27X66C1	1	. Seal
1C	27X66C2	1	. Bearing
1D		1	. Hub
1E		1	. Ring, Retaining
1F		1	. Ring, Retaining
		1	Carrier Sub-Assembly (Consisting of the following indented items):
2A		1	. Carrier
2B		12	. Washer, Thrust
2C		63	. Roller, Needle
2D		3	. Shaft, Planet
2E		3	. Gear, Planet
2F		3	. Pin, Roll
2G		2	. Washer, Thrust
		1	Piston Sub-Assembly (Consisting of the following indented items):
3A		1	. Shifter, Piston
3B	27X66C3	1	. Bearing
3C		2	. Ring, Retaining
3D		2	. Ring, Retaining
3E	27X66C4	1	. O-Ring
3F	27X66C5	1	. O-Ring
3G	27X66C6	1	. O-Ring
3H	27X66C7	1	. Ring, Back-Up
3J		1	. Collar, Shift
3K		1	. Coupling, Shift
3L		1	. Spring
3M		2	. Ring, Retaining
3N		1	. Ring, Retaining
3P		2	. Washer
4		1	Gear, Ring
5		1	Gear, Input
6		12	Bolt
		1	Plate, I.D.
		4	Screw, Drive
9	27X66C8	1	O-Ring
10		3	Plug, Pipe
11		1	Washer, Thrust

NOTE: Parts not normally stocked by Barber-Greene are subject to Vendor Minimum.

3/25/87

MASTER CYLINDER
28F39

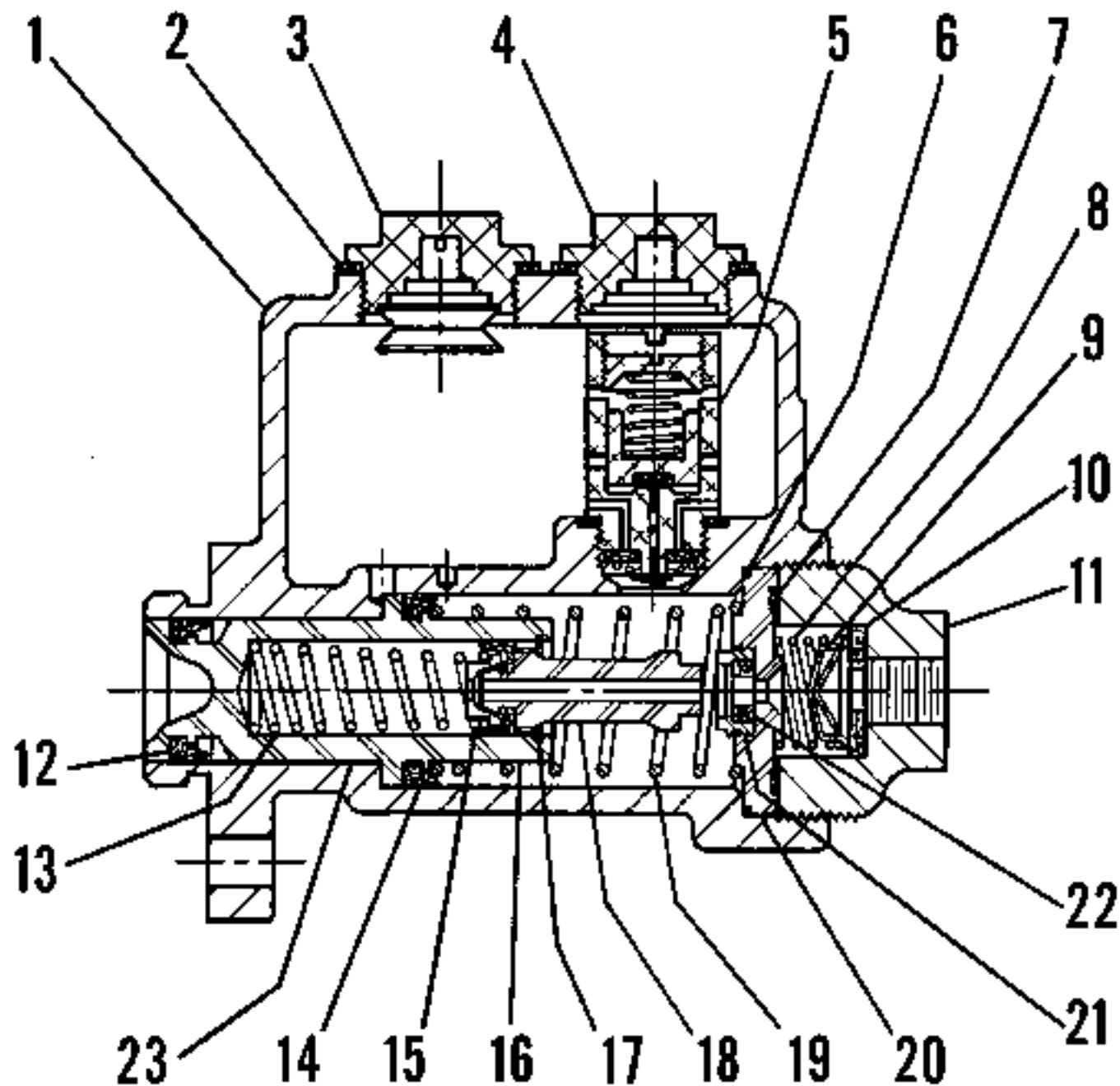

MASTER CYLINDER

28F39

(From Parking & Travel Brake Bill of Material on BG-220B, BG-240B & BG-260B)
(From Independent Wheel Brakes Bill of Material on BG-240B & BG-260B)
(Before Ordering, Consult Table of Contents to Verify Proper Bill of Material Number.)

REF.	PART NUMBER	QTY.	DESCRIPTION
1		1	Cylinder
2	a	2	Gasket
3	28F39C4	1	Filler Plug Assembly
4	28F39C3	1	Filler Plug
5	28F39C2	1	Valve, Relief
6	a	1	O-Ring
7	a	1	Seal
8		1	Spring
9	a	1	Valve, Check
10	a	1	Seat
11		1	Plug, End
12	a	1	Cup
13		1	Spring
14	a	1	Cup
15		1	Retainer
16	a	1	Cup
17	a	1	Ring, Retaining
18		1	Piston
19		1	Spring
20		1	Retainer
21	a	1	Retainer
22	a	1	Seat
23		1	Piston
		1	Boot

a - These parts contained in Repair Kit 28F39C1

NOTE: Parts not normally stocked by Barber-Greene are subject to Vendor Minimum.

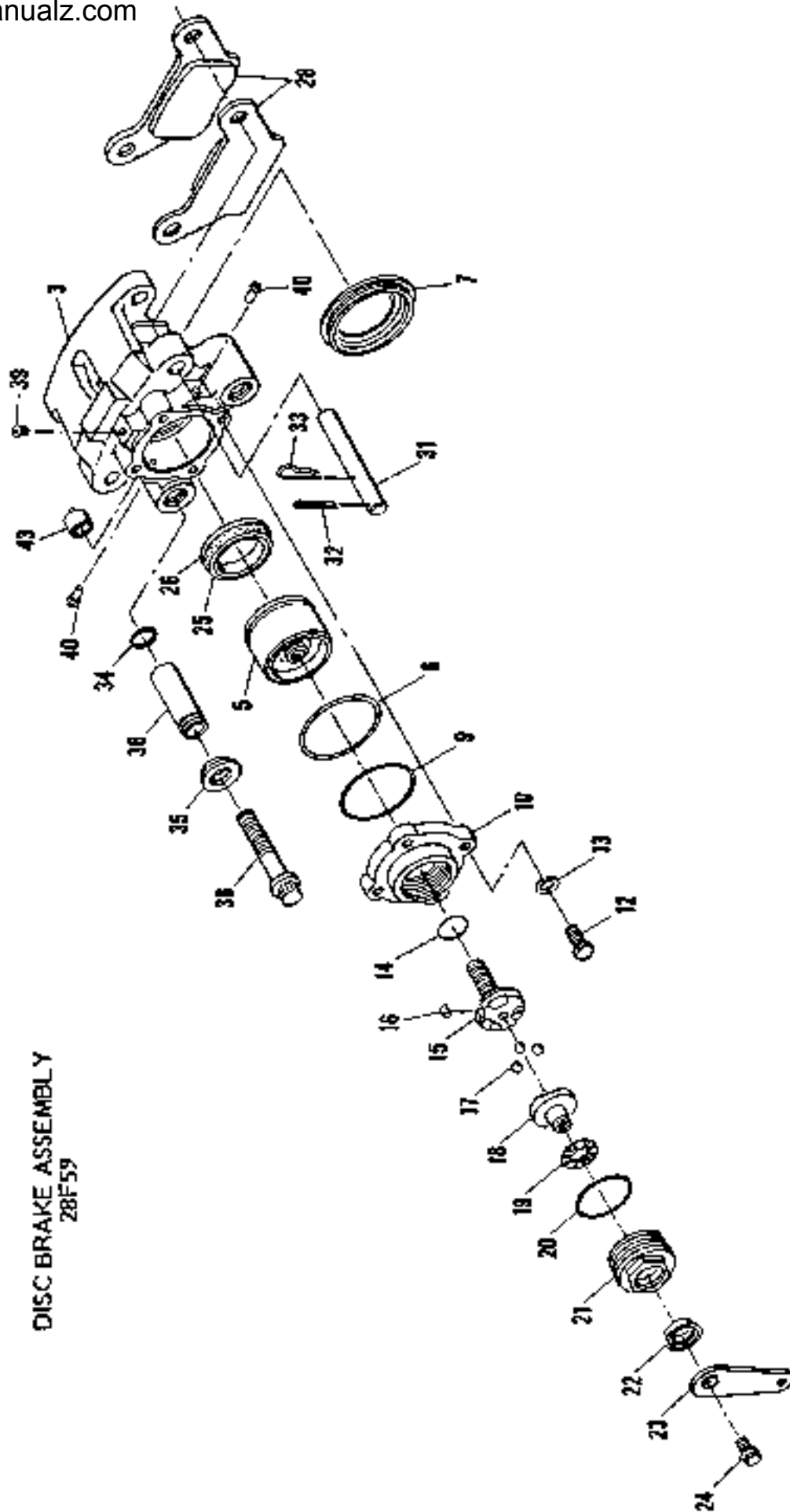

DISC BRAKE ASSEMBLY
28F59

DISC BRAKE ASSEMBLY

28F59

(From Parking & Travel Brake Bill of Material)
 (Before Ordering, Consult Table of Contents to Verify Proper Bill of Material Number.)

REF.	PART NUMBER	QTY.	DESCRIPTION
3		1	Caliper, Machined
		1	Caliper, Casting
5		1	Piston & Adjuster Assembly
6	a	1	Seal, Piston
7	a	1	Boot, Coated
		1	Boot, Plain
9	a	1	O-Ring, End Cap
10		1	Mount, Parking Brake
		1	Mount, Casting
12		4	3/8"-16 x 1" Hex Head Cap Screw
13		4	3/8" Lock Washer
14	a	1	O-Ring, Thrust Screw
15	b	1	Thrust Screw (R.H.)
16	b	1	Pin
17	b	3	Balls
18	b	1	Shaft, Actuator (R.H.)
19	b	1	Bearing, Thrust
20	a	1	O-Ring, Retainer
21	b	1	Retainer
22	a	1	Seal
23		1	Lever (R.H.)
24		1	Hex Serrated Washer Head Screw
25	c	1	Insulator
26	c	1	Extender, Piston
		1	Steel - M/S
28	28F59C1	2	Pad Holder Assembly (Two Required For Each Disc Brake Assembly)
		1	Pad Holder
		1	Steel - M/S
31		2	Pin, Pad
32		2	Pin, Cotter
33		2	Clip, Hairpin
34		2	O-Ring
35		2	Boot, Dust
36		2	Slide, Bushing
		1	Slide, Bushing - Plain
38		2	12 Pt. Flanged Screw
39		1	Insert, Tube Seat
40		2	Screw, Bleeder
		1	Plug, Cap
		1	Label, Brake Fluid
43		2	Cap, Vinyl

REF.	PART NUMBER	QTY.	DESCRIPTION
b		1	Tube, Grease

- a - These Parts Contained in Seal Kit Part Number 28F59C2.
- b - These Parts Contained in Right Park Mechanism Kit Part Number 28F59C3.
- c - These Parts Contained in Piston Extender Kit Part Number 28F59C6.

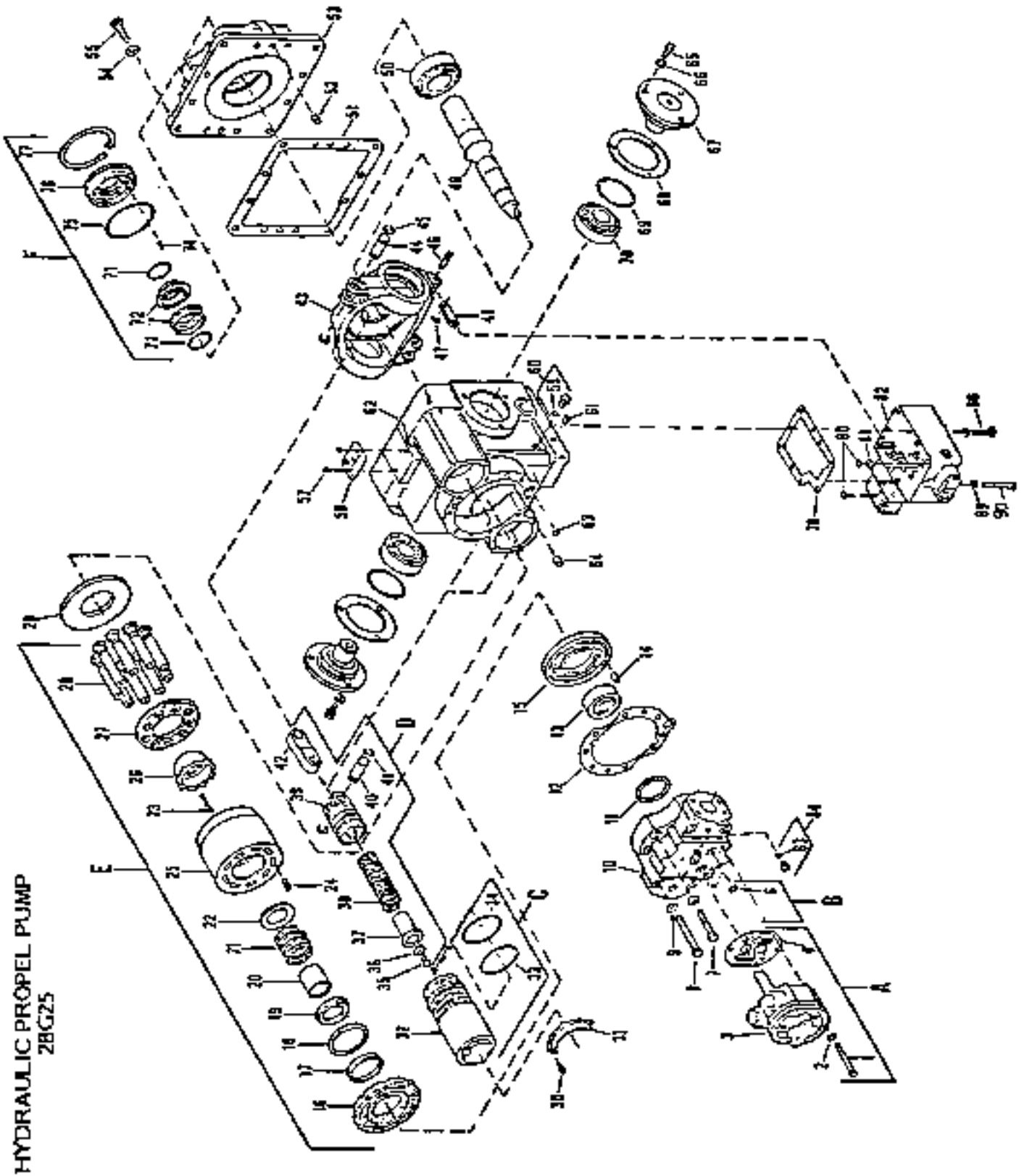

HYDRAULIC PROPEL PUMP
2BG25

HYDRAULIC PROPEL PUMP

28G25

(From Tractor Hydraulics Bill of Material)
(Before Ordering, Consult Table of Contents to Verify Proper Bill of Material Number.)

REF.	PART NUMBER	QTY.	DESCRIPTION
	28G40C5	1	Linkage Kit
7		3	Hex Head Screw
8		5	Hex Head Screw
9		9	Plain Washer
10		1	End Cap, Pump
11		1	Shim Kit
12		1	Gasket, End Cap
13		1	Bearing, Rear
14		1	Pin
15		1	Plate
29		1	Plate
30		4	Torx Screw
31		2	Sleeve, Retainer
43		1	Swashplate, Variable
44		2	Pin
45		4	Ring, Retaining
46		1	Pin
47		1	Ring, Retaining
48		1	Link
49		1	Shaft, Pump
50		1	Bearing, Front
51		1	Gasket, Front Cover
52		2	Pin
53		1	Cover, Front
54		13	Plain Washer
55		12	Hex Head Screw
57		2	Drive Screw
58		1	Nameplate
59		1	O-Ring
60		1	Plug
61		1	Plug
62		1	Housing, Variable
63	26N51C10	1	O-Ring
64		2	Pin
65		6	Hex Head Screw
66		6	Plain Washer
67		2	Trunnion
68		1	Trunnion Shim Kit
69		2	O-Ring
70		2	Bearing, Trunnion
78		1	Gasket, Control
80	26N51C10	3	O-Ring
81		2	Plug
82	28G40C4	1	Displacement, Electrical

3/25/87

(Continued)

REF.	PART NUMBER	QTY.	DESCRIPTION
86		5	Hex Head Screw
90		2	Hex Head Screw
KIT A	26N51C1	1	Charge Pump Kit (Consisting of the following indented items):
1		4	. Hex Head Screw
2	26N51C2	4	. Plain Washer
3		1	. N/A
4	26N51C3	1	. Gasket
KIT B	26N51C4	2	Check Valve Kit (Consisting of the following indented item):
6	26N51C5	2	. O-Ring
KIT C		2	Servo Kit (Consisting of the following indented items):
32		2	. Sleeve, Servo
33		2	. O-Ring
34		2	. O-Ring
KIT D		2	Piston Servo Kit (Consisting of the following indented items):
35		2	. Pointed Head Screw
36		2	. Special Washer
37		2	. Spring, Guide
38		2	. Spring, Servo
39		2	. Piston, Servo
40		2	. Pin
41		4	. Ring, Retaining
42		2	. Link
KIT E		1	Cylinder Block Kit (Consisting of the following indented items):
16		1	. Plate, Bearing
17		1	. Plate, Pilot Bearing
18	26J91C1	1	. Ring, Retaining
19		1	. Spring, Retainer
20		1	. Guide, Spring
21		1	. Spring, Cylinder Block
22		1	. Seat, Spring
23		6	. Retainer, Spring
24		1	. Pin
25		1	. Cylinder Block Assembly
26		1	. Guide
27		1	. Retainer
28		9	. Piston
KIT F	26N51C7	1	Seal Kit (Consisting of the following indented items):
71		2	. O-Ring
72	26N51C8	1	. Seal Kit
74	26N51C9	6	. Spring, Seal
75		1	. O-Ring
76		1	. Retainer, Seal
77		1	. Ring, Retaining

ELECTRIC SHIFT UNIT
281,27

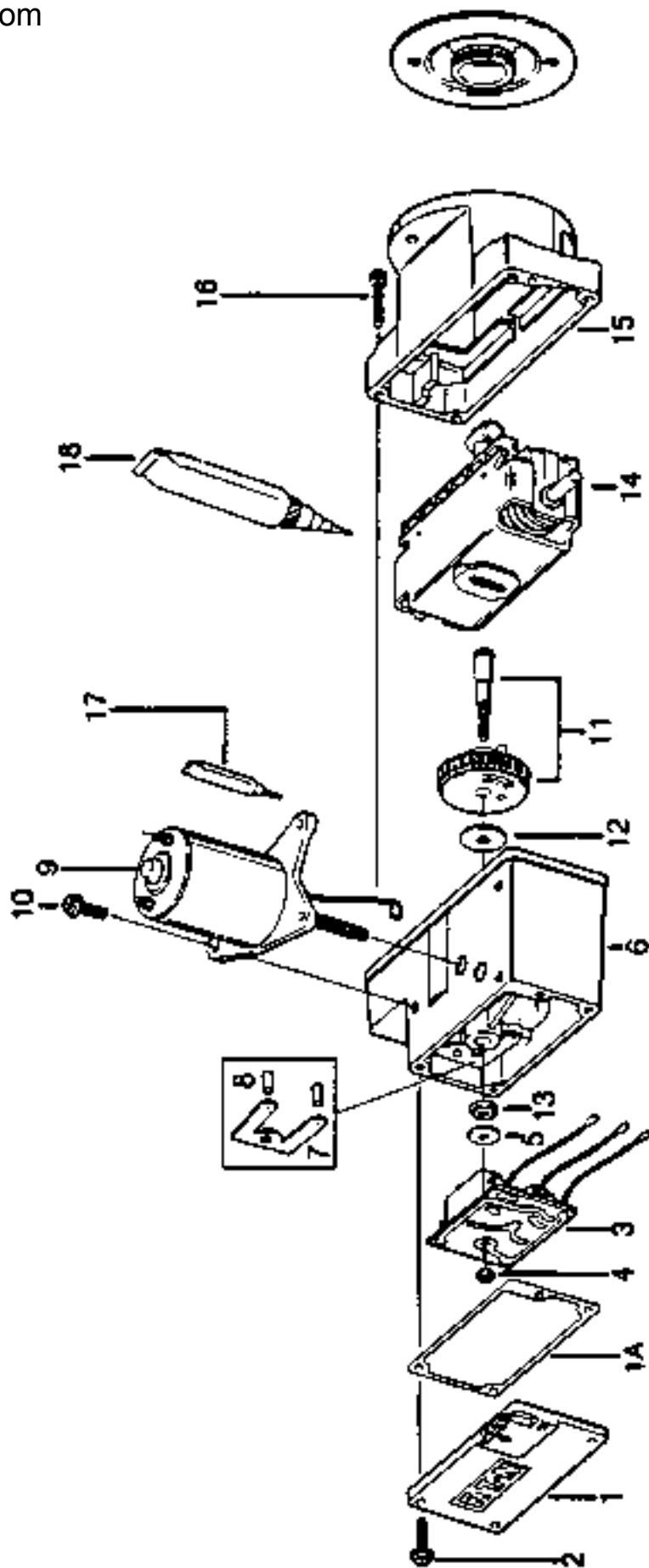

ELECTRIC SHIFT UNIT

28L27

(From Drive Axle Assembly Bill of Material)
 (Before Ordering, Consult Table of Contents to Verify Proper Bill of Material Number.)

REF.	PART NUMBER	QTY.	DESCRIPTION
1		1	Cover Assembly
1A		1	Gasket, Cover
2		4	Hex Head Cap Screw
3	a	1	Board, Circuit
4	a, c	1	Lock Nut
5	a, c	1	Washer
6		1	Motor Housing & Switch Spring Assembly
7		1	Spring, Switch
8	c	2	Pin, Carr.
9	b	1	Motor
10		3	Hex Head Cap Screw
11	c	1	Gear Assembly & Shaft
12	c	1	Washer
13	c	1	Lock Nut
14	28L27C4	1	Slider Block & Shaft Assembly
15		1	Housing, Base
16		4	Hex Socket Head Screw
17	b, c	1	Lubricant
18		1	Compound, Gasket

a - These items are contained in Circuit Board Assembly Kit Part Number 28L27C1.

b - These items are contained in Motor & Lubricant Kit Part Number 28L27C2

c - These items are contained in Gear Assembly & Shaft Kit 28L27C3.

Note: Only normally serviced items are listed.

HYDRAULIC FEEDER & SCREW TANDEM PUMP
(Front Section)

(Illustration 1 of 2)
28L38

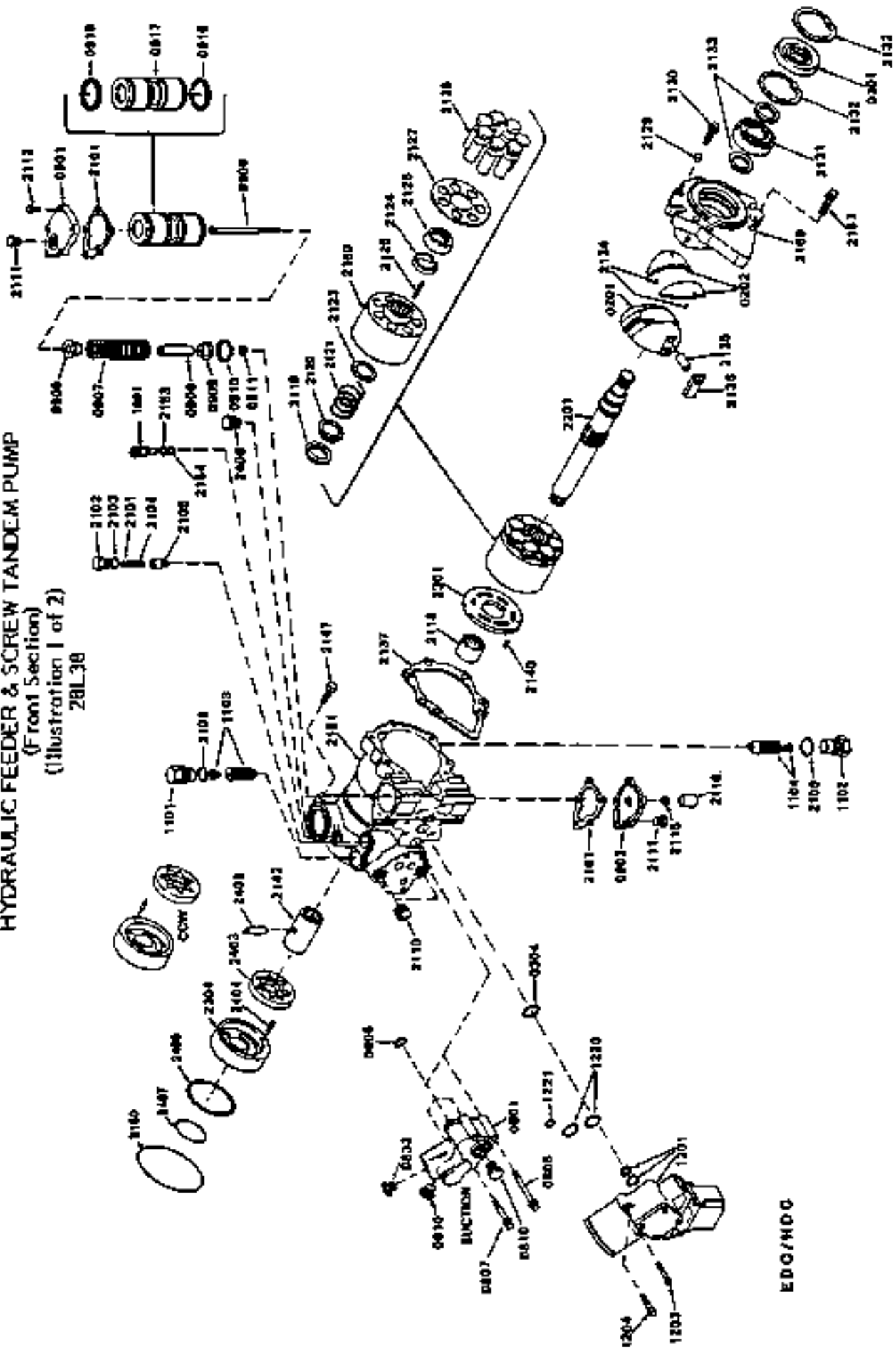

EDO/MCO

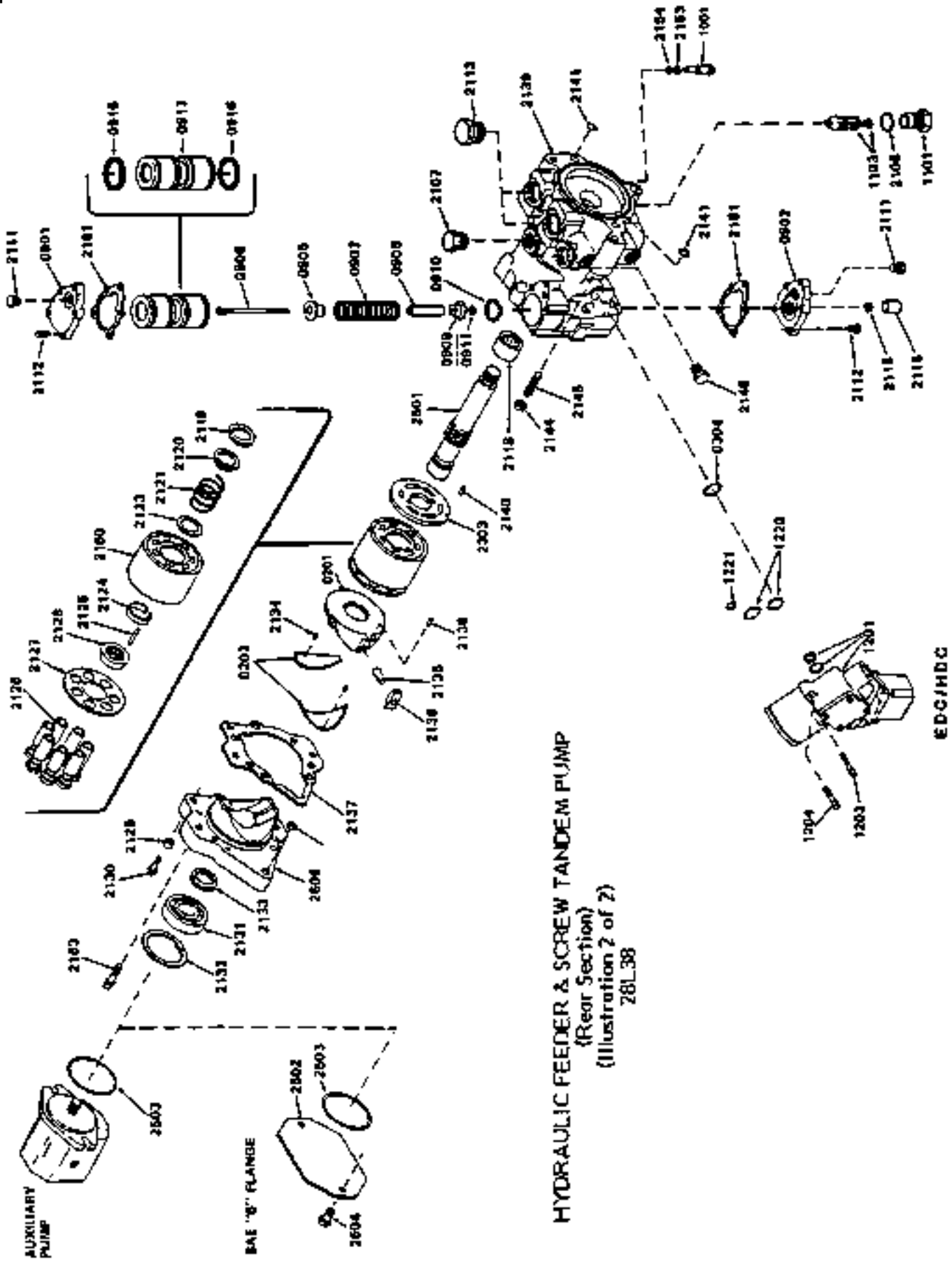

HYDRAULIC FEEDER & SCREW TANDEM PUMP
(Rear Section)
(Illustration 2 of 2)
28L38

EDC/HDC

HYDRAULIC FEEDER & SCREW TANDEM PUMP

28L39

(From Tractor Hydraulics Bill of Material)
 (Before Ordering, Consult Table of Contents to Verify Proper Bill of Material Number.)

REF.	PART NUMBER	QTY.	DESCRIPTION
		2	Swashplate Group #02 (For Front & Rear Pumps) <u>(Each Swashplate Group consists of the following indented items):</u>
0201		1	. Swashplate
0202		2	. Bearing Journal
		1	Seal Group #03 <u>(Each Seal Group consists of the following indented items):</u>
0301		1	. Seal, Lip (Front Pump)
0304		1	. O-Ring
0304		2	. O-Ring (Rear Pump)
		1	Filtration Group #08 (For Front Pump) <u>(Each Filtration Group consists of the following indented items):</u>
0801		1	. Adapt Suction Filtered Inlet
0805		3	. O-Ring
0806		2	. Screw
0807		1	. Screw
0810		2	. Plug
0833		1	. Plug
		2	Displacement Group #09 (For Front & Rear Pumps) <u>(Each Displacement Group consists of the following indented items):</u>
0901		1	. Cover, Servo
0902		1	. Cover, Servo
0905		1	. Guide, Spring
0906		1	. Stop, Servo
0907		1	. Spring, Servo
0908		1	. Screw
0909		1	. Guide, Spring
0910		1	. Ring, Retaining
0911		1	. Lock Nut
0916		2	. Ring, Piston
0917		1	. Piston, Servo
		2	Bypass Valve Group #10 (For Front & Rear Pumps) <u>(Each Bypass Valve Group consists of the following indented item):</u>
1001		1	. Valve, Bypass (Without Orifice)
		2	System Pressure Protection Group #11 (For Front & Rear Pumps) <u>(Each System Pressure Protection Group consists of the following indented items):</u>
1101		1	. Plug
1102		1	. Plug
1103		1	. Valve, Relief / Check
1104		1	. Valve, Relief / Check

3/25/87

(Continued)

REF.	PART NUMBER	QTY.	DESCRIPTION
		2	Control Group #12 (For Front & Rear Pumps) <u>(Each Control Group consists of the following indented items):</u>
1201		1	. Control (EDC)
1203		2	. Screw
1204		2	. Socket Head Screw
1220		2	. O-Ring
1221		1	. O-Ring
		2	Control Orifice Group #14 (For Front & Rear Pumps) <u>(Each Control Orifice Group consists of the following indented items):</u>
		1	. Plug, Orifice
		1	. Plug, Orifice
		2	Common Parts Group #21 (For Front & Rear Pumps) <u>(Each Common Parts Group consists of the following indented items):</u>
2101		1	. Shim Set
2102		1	. Plug
2103		1	. O-Ring
2104		1	. Spring
2105		1	. Valve
2106		4	. O-Ring
2107		3	. Plug
2110		2	. Plug
2111		4	. Plug
2112		20	. Hex Head Screw
2113		4	. Plug
2115		2	. Nut
2116		2	. Cover
2118		2	. Bearing, Needle
2119		2	. Ring, Retaining
2120		2	. Washer
2121		2	. Spring, Cylinder Block
2123		2	. Washer
2124		2	. Retainer
2125		6	. Pin
2126		14	. Piston Assembly
2127		2	. Guide
2128		2	. Guide
2129		2	. Pin, Spring
2130		2	. Screw
2131		2	. Bearing, Ball
2132		3	. Ring
2133		3	. Ring
2134		4	. Pin
2135		2	. Pin
2136		2	. Sleeve, Bearing
2137		2	. Gasket, Front Cover
2138		2	. Pin
2139		1	. Housing

REF.	PART NUMBER	QTY.	DESCRIPTION
2140		2	. Pin
2141		2	. O-Ring
2142		1	. Coupling
2144		1	. Nut
2145		1	. Stud
2147		2	. Screw
2148		2	. Plug
2150		1	. O-Ring
2151		1	. Housing
2153		2	. Ring, Back-Up
2154		2	. O-Ring
2155		2	. Plug
2159		1	. Cover, Front
2160		2	. Block, Cylinder
2161		4	. Gasket, Servo Cover
2163		12	. Screw
		1	Drive Shaft Group #22 (For Front Pump) (Each Drive Shaft Group consists of the following indented item):
2201		1	. Shaft, Pump (15 T. Splined)
		1	Rotation / Charge Pump Group #23 (For Front Pump) (Each Rotation / Charge Pump Group consists of the following indented items):
2301		1	. Plate, Valve
2303		1	. Plate, Valve
2304		1	. Cover, Gerotor
		1	Charge Pump Displacement Group #24 (For Front Pump) (Each Charge Pump Displacement Group consists of the following indented items):
2403		1	. Gerotor Assembly
2404		1	. Pin
2405		1	. Pin
2406		1	. Plug, Plastic
2407		1	. O-Ring
2408		1	. O-Ring
		1	Auxiliary Flange Group #25 (For Rear Pump) (Each Auxiliary Flange Group consists of the following indented items):
2501		1	. Shaft, Pump
2502		1	. Plate, Cover
2503		1	. O-Ring
2504		2	. Hex Head Screw
2506		1	. Cover, Rear

All information contained on the pump identification tag is required for proper part number identification. Your order can not be processed without this information.

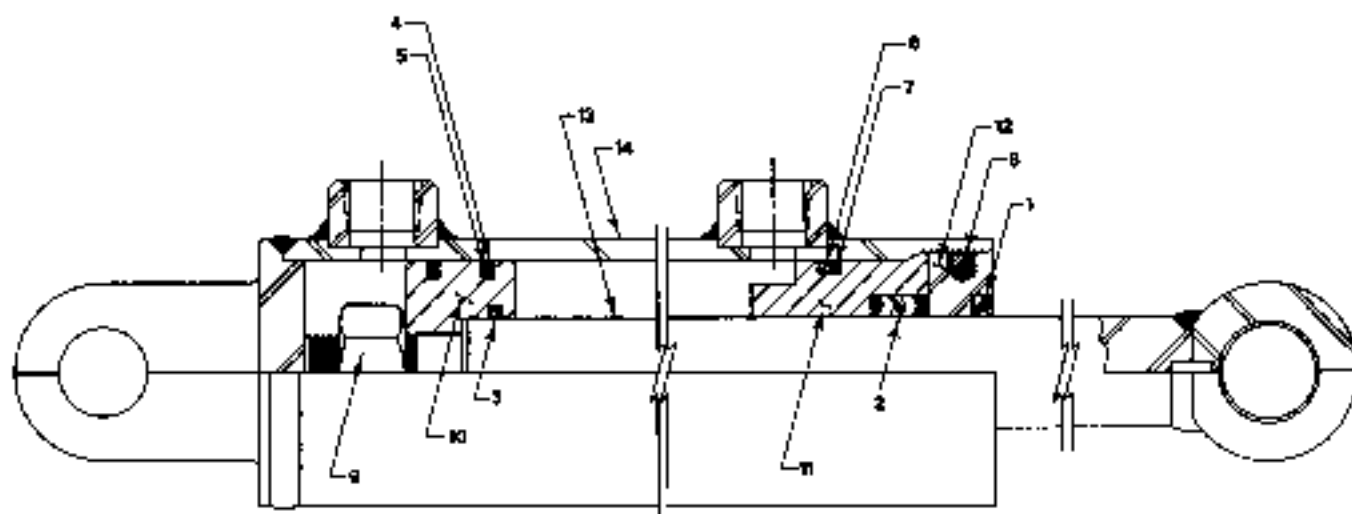

**HYDRAULIC CYLINDER
(Screed Lift)**

28L43

(From Tractor Hydraulics Bill of Material)

(Before Ordering, Consult Table of Contents to Verify Proper Bill of Material Number.)

REF.	PART NUMBER	QTY.	DESCRIPTION
	26L95C1	1	Kit, Seal (Consisting of the following indented items):
1		1	• Wiper, Lip Type
2		1	• Vee Seat
3		1	• O-Ring
4		2	• Ring, Teflon
5		2	• O-Ring
6		1	• O-Ring
7		1	• Back-Up
8		1	• Plug, Nylon
9		1	Nut
10		1	Piston
11		1	Bearing
12		1	Retainer
13		1	Rod Assembly
14		1	Tube Assembly

Parts not normally stocked by Barber-Greene are subject to Vendor Minimum.

3/25/87

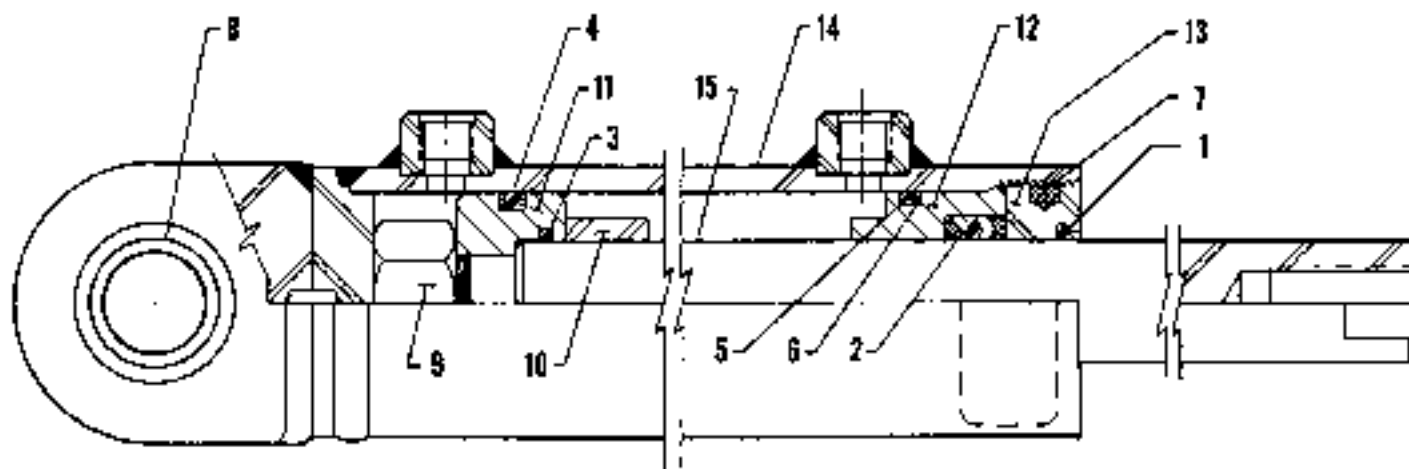

HYDRAULIC CYLINDER
(Steering)

28M35

(From Tractor Hydraulics Bill of Material)
(Before Ordering, Consult Table of Contents to Verify Proper Bill of Material Number.)

REF.	PART NUMBER	QTY.	DESCRIPTION
	28H10C1		Kit, Seal (Consisting of the following Indented Items):
1			. Wiper
2			. Vee - Set
3			. O-Ring
4			. T-Ring
5			. O-Ring
6			. Back-Up
7			. Plug, Nylon
8			Bushing
9			Nut
10			Spacer
11			Piston
12			Bearing
13			Retainer
14			Tube Assembly
15			Rod

3/25/87

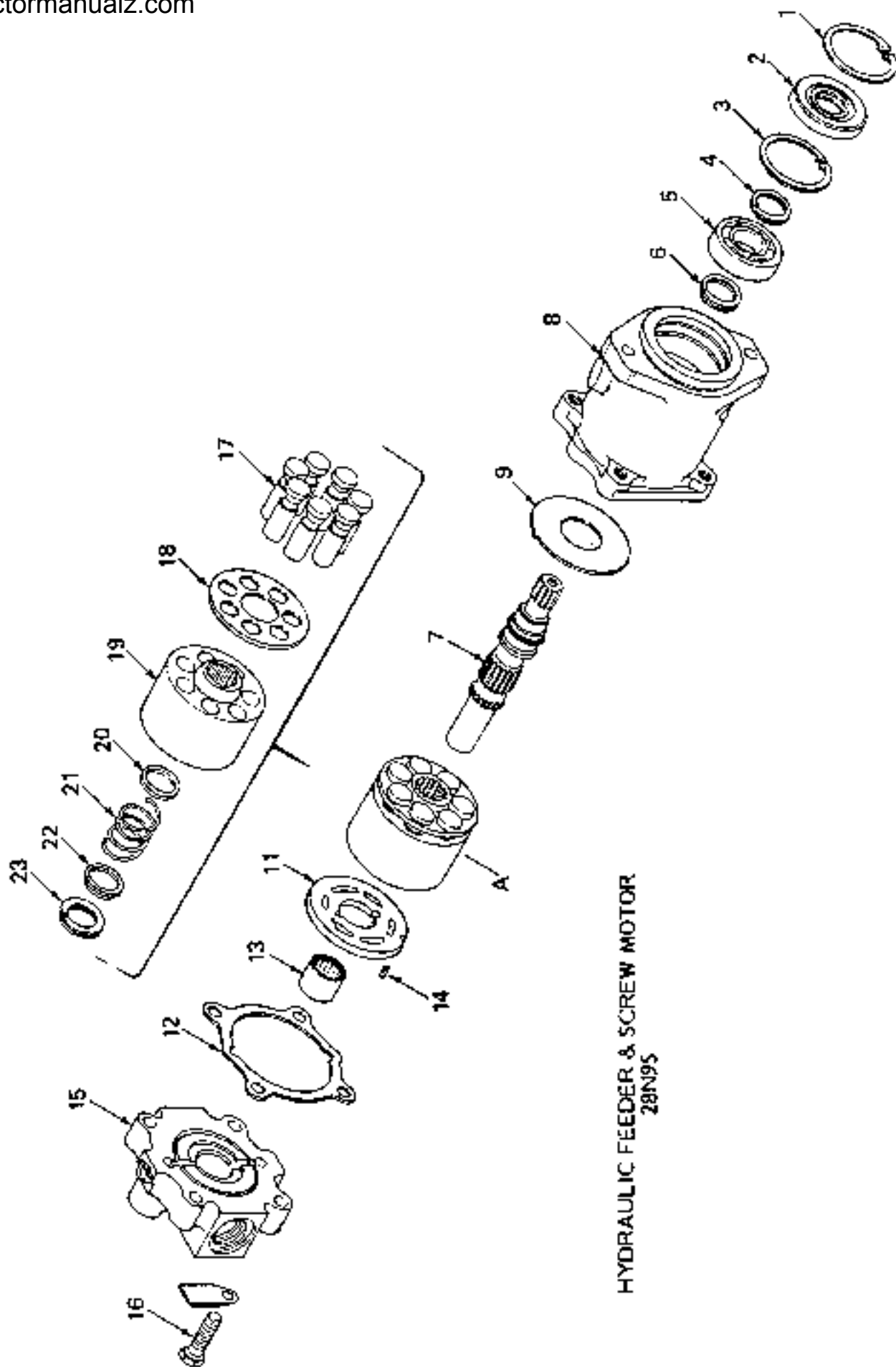

HYDRAULIC FEEDER & SCREW MOTOR
28N95

HYDRAULIC FEEDER & SCREW MOTOR

28N95

(From Tractor Hydraulics Bill of Material)
(Before Ordering, Consult Table of Contents to Verify Proper Bill of Material Number.)

REF.	PART NUMBER	QTY.	DESCRIPTION
1		1	Ring
2	28N95C3	1	Seal, Lip
3		1	Ring
4		1	Ring
5	28N95C1	1	Bearing, Ball
6		1	Ring
7		1	Shaft, Motor
8		1	Housing, Fixed
9		1	Plate, Thrust
11		1	Plate, Motor
12		1	Gasket, End Cap
13	28N95C2	1	Bearing, Needle
14		1	Pin
15		1	End Cap, Motor
16		4	Screw
KIT A		1	Cylinder Block Kit (Consisting of the following indented items):
17		7	. Piston Assembly
18		1	. Retainer
19		1	. Block, Cylinder
20		1	. Washer
21		1	. Spring, Cylinder Block
22		1	. Washer
23		1	. Ring, Retaining

**PUMP DRIVE GEARBOX
(Triple Pump)
28P34**

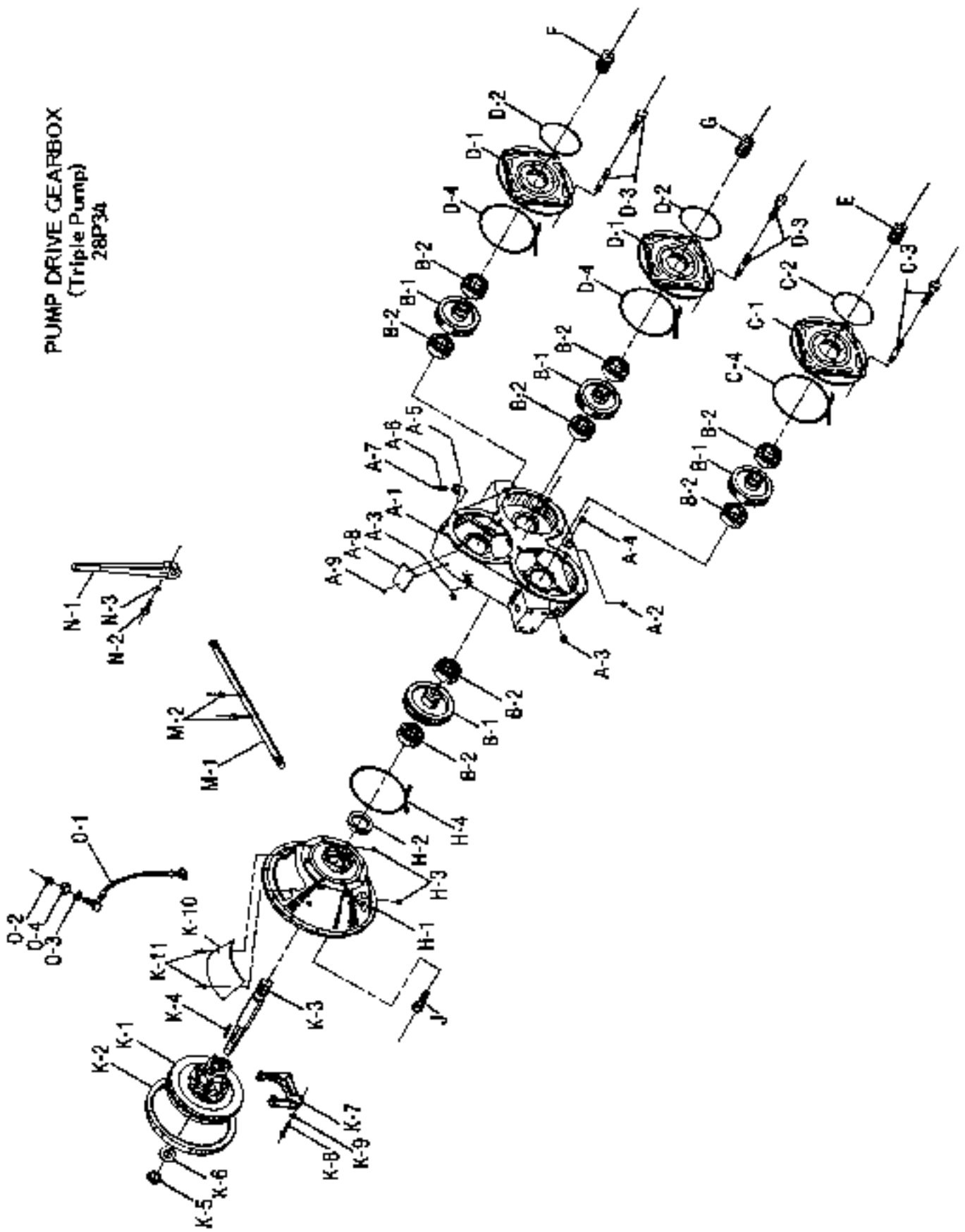

3/25/87

**PUMP DRIVE GEARBOX
(Triple Pump)**

28P34

(From Power Unit Bill of Material)

(Before Ordering, Consult Table of Contents to Verify Proper Bill of Material Number.)

REF.	PART NUMBER	QTY.	DESCRIPTION
		1	Housing Group (Consisting of the following indented items):
A-1		1	. Housing, Triple Pump
A-2		1	. Plug, Magnetic
A-3		4	. Plug, Pipe
A-4		1	. Plug, Pipe
A-5		1	. Elbow, 90°
A-6		1	. Bushing, Reducer
A-7		1	. Breather (1-5 PSI)
A-8		1	. Nameplate, Serial Number
A-9		2	. Screw, Drive
		2	. Plug, Expansion
		1	Group, Gear (Consisting of the following indented items):
B-1	27X80C5	4	. Gear
B-2	27X80C6	8	. Bearing
		1	Group, Pump Adaptor C
C-1	27V89C7	1	. Adaptor, Pump
C-2	27V89C18	1	. O-Ring
C-3		4	. Bolt, Adapter
C-4	a	1	. Gasket, Plastic Strip
		2	Group, Pump Adaptor B (Consisting of the following indented items):
D-1	27X80C1	1	. Adaptor, Pump
D-2	27V89C17	1	. O-Ring
D-3		4	. Bolt, Adapter
D-4	a	1	. Gasket, Plastic Strip
E	27V89C9	1	Sleeve, Adaptor
F	27V89C8	1	Sleeve, Adaptor
G	27V89C10	1	Sleeve, Adaptor
		1	Assembly, Clutch Housing (Consisting of the following indented items):
H-1		1	. Housing, Clutch
H-2	27V89C21	1	. Seal, Oil
H-3		2	. Fitting, Grease
H-4	27V89C11	2	. Gasket, Plastic Strip
J		7	Bolt, Adapter
		1	Group, Clutch (Consisting of the following indented items):
K-1	27V89C6	1	. Assembly, Clutch
K-2	27V89C3	1	. Ring, Drive
K-3	27X80C4	1	. Shaft, Drive Clutch
K-4	27V89C19	1	. Key, Square

3/25/87

(Continued)

REF.	PART NUMBER	QTY.	DESCRIPTION
K-5	27V89C2	1	. Nut
K-6	27X80C2	1	. Lock Washer
K-7	27V89C5	1	. Yoke
K-8	27V89C15	2	. Cap Screw
K-9	27V89C16	2	. Lock Washer
K-10		1	. Nameplate
K-11		2	. Screw
		1	Group, Throwout Shaft (Consisting of the following indented items):
M-1		1	. Shaft, Clutch
M-2		2	. Key, Woodruff
		1	Assembly, Clutch Handle (Consisting of the following indented items):
N-1	27V89C1	1	. Handle, Clutch Release
N-2		1	. Cap Screw
N-3		1	. Lock Washer
		1	Group, Lube Hose (Consisting of the following indented items):
O-1		1	. Assembly, Flexible Hose
O-2		1	. Fitting, Grease
O-3		1	. Star Washer
O-4		1	. Nut

a - Be sure to specify length when ordering.

Parts not normally stocked by Barber-Greene are subject to vendor minimum.

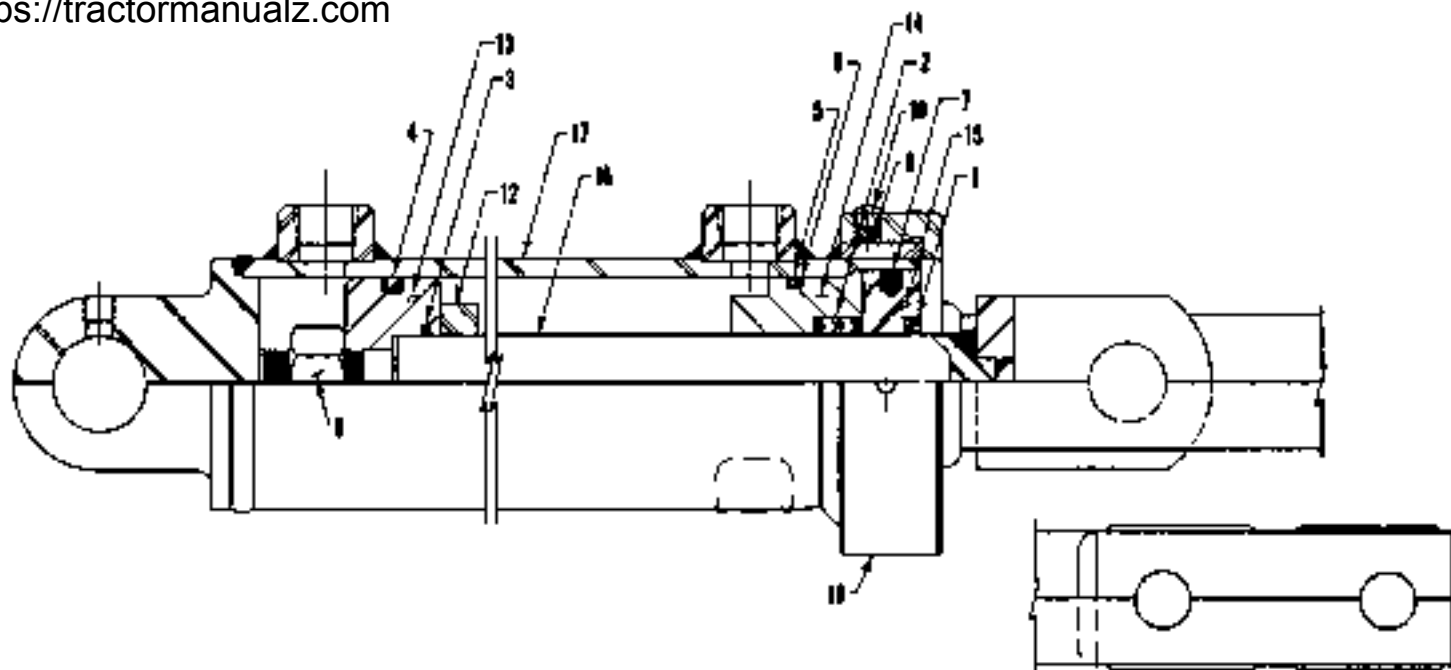

**HYDRAULIC CYLINDER
(Auto Grade Control)**

28W09

(From Automatic Grade Control Hydraulics Bill of Material)
(Before Ordering, Consult Table of Contents to Verify Proper Bill of Material Number.)

REF.	PART NUMBER	QTY.	DESCRIPTION
	27X78C1		Kit, Seal (Consisting of the following indented items):
1			. Wiper, Lip Type
2			. Vee Set
3			. O-Ring
4			. T-Ring
5			. O-Ring
6			. Back-Up
7			. Nylon Plug
8			. Nylon Plug
9			Nut
10			Set Screw
12			Spacer
13			Piston
14			Bearing
15			Retainer
16			Rod Assembly
17			Tube Assembly
18			Clevis Assembly

Parts not normally stocked by Barber-Greene are subject of Vendor Minimum.

3/25/87

