

Operation & Maintenance Manual

PEN00020-00

GALEO BR550JG-1

MOBILE CRUSHER

SERIAL NUMBERS 1001 and up

⚠ WARNING

Unsafe use of this machine may cause serious injury or death. Operators and maintenance personnel must read this manual before operating or maintaining this machine. This manual should be kept near the machine for reference and periodically reviewed by all personnel who will come into contact with it.

NOTICE

Komatsu has Operation & Maintenance Manuals written in some other languages. If a foreign language manual is necessary, contact your local distributor for availability.

KOMATSU

FOREWORD

CALIFORNIA

Proposition 65 Warning

Diesel engine exhaust and some of its constituents are known to the State of California to cause cancer, birth defects, and other reproductive harm.

CALIFORNIA

Proposition 65 Warning

Battery posts, terminals and related accessories contain lead and lead compounds, chemicals known to the State of California to cause cancer and birth defects or other reproductive harm.

Wash hands after handling.

FOREWORD

This manual provides rules and guidelines which will help you use this machine safely and effectively. The precautions in this manual must be followed at all times when performing operation and maintenance. Most accidents are caused by the failure to follow fundamental safety rules for the operation and maintenance of machines. Accidents can be prevented by knowing beforehand conditions that may cause a hazard when performing operation and maintenance.



WARNING

Operators and maintenance personnel must always do as follows before beginning operation or maintenance.

- Always be sure to read and understand this manual thoroughly before performing operation and maintenance.
- Read the safety messages given in this manual and the safety labels affixed to the machine thoroughly and be sure that you understand them fully.

Keep this manual at the storage location for the operation and maintenance manual given below, and have all personnel read it periodically.

If this manual has been lost or has become dirty and cannot be read, request a replacement manual immediately from Komatsu or your Komatsu distributor.

If you sell the machine, be sure to give this manual to the new owners together with the machine.

Komatsu delivers machines that comply with all applicable regulations and standards of the country to which it has been shipped. If this machine has been purchased in another country or purchased from someone in another country, it may lack certain safety devices and specifications that are necessary for use in your country. If there is any question about whether your product complies with the applicable standards and regulations of your country, consult Komatsu or your Komatsu distributor before operating the machine.

Storage location for the Operation and Maintenance Manual:
Main Control Box

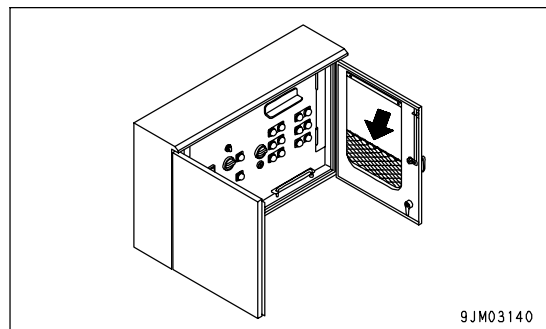

EMISSION CONTROL WARRANTY

EMISSION CONTROL WARRANTY STATEMENT (APPLIES TO CANADA ONLY)

1. Products Warranted

Komatsu America International Company, Komatsu Mining Systems Inc. and Komatsu Utility Corporation (collectively "Komatsu") produce and/or market products under brand names of Komatsu, Dresser, Dressa, Hiralpak and Galien. This emissions warranty applies to new engines bearing the Komatsu name installed in these products and used in Canada in machines designed for industrial off-highway use. This warranty applies only to these engines produced on or after January 1, 2000. This warranty will be administered by Komatsu distribution in Canada.

2. Coverage

Komatsu warrants to the ultimate purchaser and each subsequent purchaser that the engine is designed, built and equipped so as to conform, at the time of sale by Komatsu, with all U.S. Federal emission regulations applicable at the time of manufacture and that it is free from defects in workmanship or material which would cause it not to meet these regulations within five years or 3,000 hours of operation, whichever occurs first, as measured from the date of delivery of the engine to the ultimate purchaser.

3. Limitations

Failures, other than those resulting from defects in materials or workmanship, are not covered by this warranty. Komatsu is not responsible for failures or damage resulting from what Komatsu determines to be abuse or neglect, including, but not limited to: operation without adequate coolant or lubricants; over fueling; over speeding; lack of maintenance of lubricating, cooling or intake systems; improper storage, starting, warm-up, run-in or shutdown practices; unauthorized modifications of the engine. Komatsu is also not responsible for failures caused by incorrect fuel or by water, dirt or other contaminants in the fuel. Komatsu is not responsible for non-engine repairs, "down-time" expense, related damage, fines, all business costs or other losses resulting from a warrantable failure.

KOMATSU IS NOT RESPONSIBLE FOR INCIDENTAL OR CONSEQUENTIAL DAMAGES.

This warranty, together with the express commercial warranties, are the sole warranties of Komatsu. **THERE ARE NO OTHER WARRANTIES, EXPRESS OR IMPLIED, OR OF MERCHANTABILITY OR FITNESS FOR A PARTICULAR PURPOSE.**

GARANTIE SUR LE CONTRÔLE DES ÉMISSIONS

ÉNONCÉ DE GARANTIE SUR LE CONTRÔLE DES ÉMISSIONS (APPLICABLE AU CANADA SEULEMENT):

1. Produits garantis:

Komatsu America International Company, Komatsu Mining Systems Inc. et Komatsu Utility Corporation (collectivement Komatsu) produisent et/ou font la mise en marché de produits portant les noms de marque Komatsu, Dresser, Dressa, Hiralpak et Galien. Cette garantie sur les émissions s'applique à tous les nouveaux moteurs portant le nom Komatsu, installés dans ces produits et utilisés au Canada dans des machines conçues pour utilisation industrielle non-routière. Cette garantie s'applique seulement sur les moteurs produits à partir du 1er janvier 2000. Cette garantie sera administrée par la distribution de Komatsu au Canada.

2. Couverture:

Komatsu garantit à l'acheteur ultime et chaque acheteur subséquent que le moteur est conçu, construit et équipé en toute conformité, au moment de la vente par Komatsu, avec toutes les Réglementations fédérales américaines sur les émissions applicables au moment de la fabrication et qu'il est exempt de défauts de construction ou de matériaux qui auraient pour effet de contrevenir à ces réglementations en delà de 5 ans ou 3000 heures d'opération, mesuré à partir de la date de livraison du moteur au client ultime.

3. Limitations:

Les bris, autres que ceux résultant de défauts de matériaux ou de construction, ne sont pas couverts par cette Garantie. Komatsu n'est pas responsable pour bris ou dommages résultant de ce que Komatsu détermine comme étant de l'abus ou négligence, incluant mais ne se limitant pas à: l'opération sans lubrifiants ou agent refroidissants adéquats; la suralimentation d'essence; la survilleuse; le manque d'entretien des systèmes de lubrification, de refroidissement ou d'entrée; de pratiques non-propices d'entreposage, de mise en marche, de réchauffement, de conditionnement ou d'arrêt; les modifications non-autorisées du moteur. De plus, Komatsu n'est pas responsable de bris causés par de l'essence inadéquate ou de l'eau, des sels ou autres contaminants dans l'essence. Komatsu n'est pas responsable des réparations non-relées au moteur, des dépenses encourues suite aux temps d'arrêts, des dommages relatifs, amendes, et de tout autre coût d'affaires ou autres pertes résultant d'un bris couvert par la garantie.

KOMATSU N'EST PAS RESPONSABLE DES INCIDENTS OU DOMMAGES CONSÉQUENTS.

Cette garantie, ainsi que les garanties expresses commerciales, sont les seules garanties de Komatsu. **IL N'Y A AUCUNE AUTRE GARANTIE, EXPRESSE OU SOUS-ENTENDUE, MARCHANDABLE OU PROPICE À UNE UTILISATION PARTICULIÈRE.**

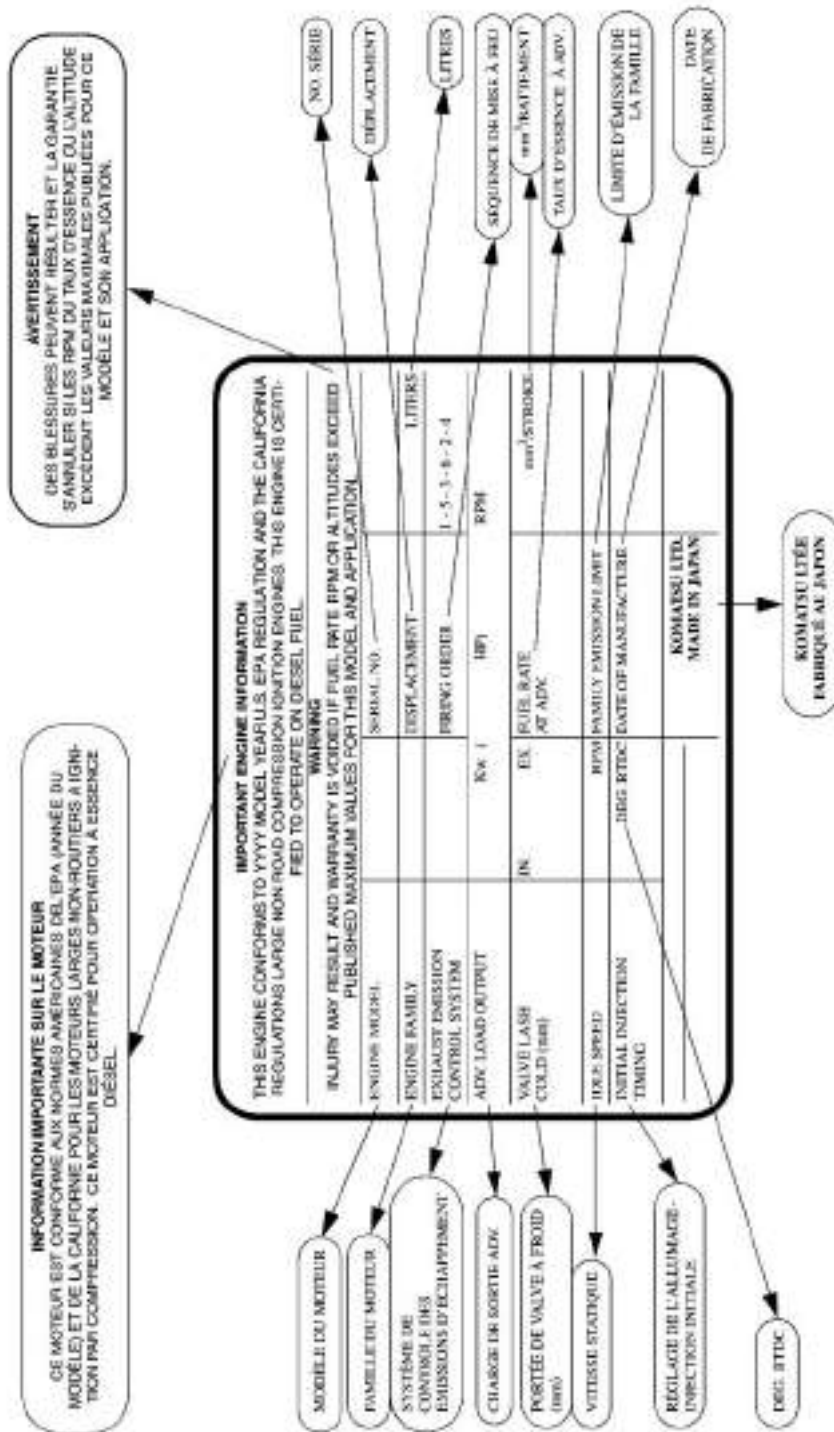

ENGINE DATA PLATE - ENGLISH / FRENCH

SAFETY INFORMATION

To enable you to use this machine safely, safety precautions and labels are given in this manual and affixed to the machine to give explanations of situations involving potential hazards and of the methods of avoiding such situations.

Signal words

The following signal words are used to inform you that there is a potential hazardous situation that may lead to personal injury or damage.

In this manual and on machine labels, the following signal words are used to express the potential level of hazard.



Indicates an imminently hazardous situation which, if not avoided, will result in death or serious injury.



Indicates a potentially hazardous situation which, if not avoided, could result in death or serious injury.



Indicates a potentially hazardous situation which, if not avoided, may result in minor or moderate injury. This word is used also to alert against unsafe practices that may cause property damage.

Example of safety message using signal word



When standing up from the operator's seat, always place the lock lever in the **LOCK** position.

If you accidentally touch the control levers when they are not locked, this may cause a serious injury or death.

Other signal words

In addition to the above, the following signal words are used to indicate precautions that should be followed to protect the machine or to give information that is useful to know.

NOTICE

This word is used for precautions that must be taken to avoid actions which could shorten the life of the machine.

REMARKS

This word is used for information that is useful to know.

- Safety labels

Safety labels are affixed to the machine to inform the operator or maintenance worker on the spot when carrying out operation or maintenance of the machine that may involve hazard.

This machine uses "Safety labels using words" and "Safety labels using pictograms" to indicate safety procedures.

Example of safety label using words



Part No.

Safety labels using pictogram

Safety pictograms use a picture to express a level of hazardous condition equivalent to the signal word. These safety pictograms use pictures in order to let the operator or maintenance worker understand the level and type of hazardous condition at all times. Safety pictograms show the type of hazardous condition at the top or left side, and the method of avoiding the hazardous condition at the bottom or right side. In addition, the type of hazardous condition is displayed inside a triangle and the method of avoiding the hazardous condition is shown inside a circle.



Part No.

Komatsu cannot predict every circumstance that might involve a potential hazard in operation and maintenance. Therefore, the safety messages in this manual and on the machine may not include all possible safety precautions. If any procedures or actions not specifically recommended or allowed in this manual are used, it is your responsibility to take the necessary steps to ensure safety.

In no event should you engage in prohibited uses or actions described in this manual.

The explanations, values, and illustrations in this manual were prepared based on the latest information available at that time. Continuing improvements in the design of this machine can lead to changes in detail which may not be reflected in this manual. Consult Komatsu or your Komatsu distributor for the latest available information of your machine or for questions regarding information in this manual.

The numbers in circles in the illustrations correspond to the numbers in () in the text. (For example: ① -> (1))

INTRODUCTION

This Komatsu machine is designed to be used mainly for the following work:

- Crushing Operation

For details on operations, please refer to the section "SCOPE OF WORKS USING MOBILE CRUSHER (PAGE 3-86)".

FRONT/REAR, LEFT/RIGHT DIRECTIONS OF MACHINE

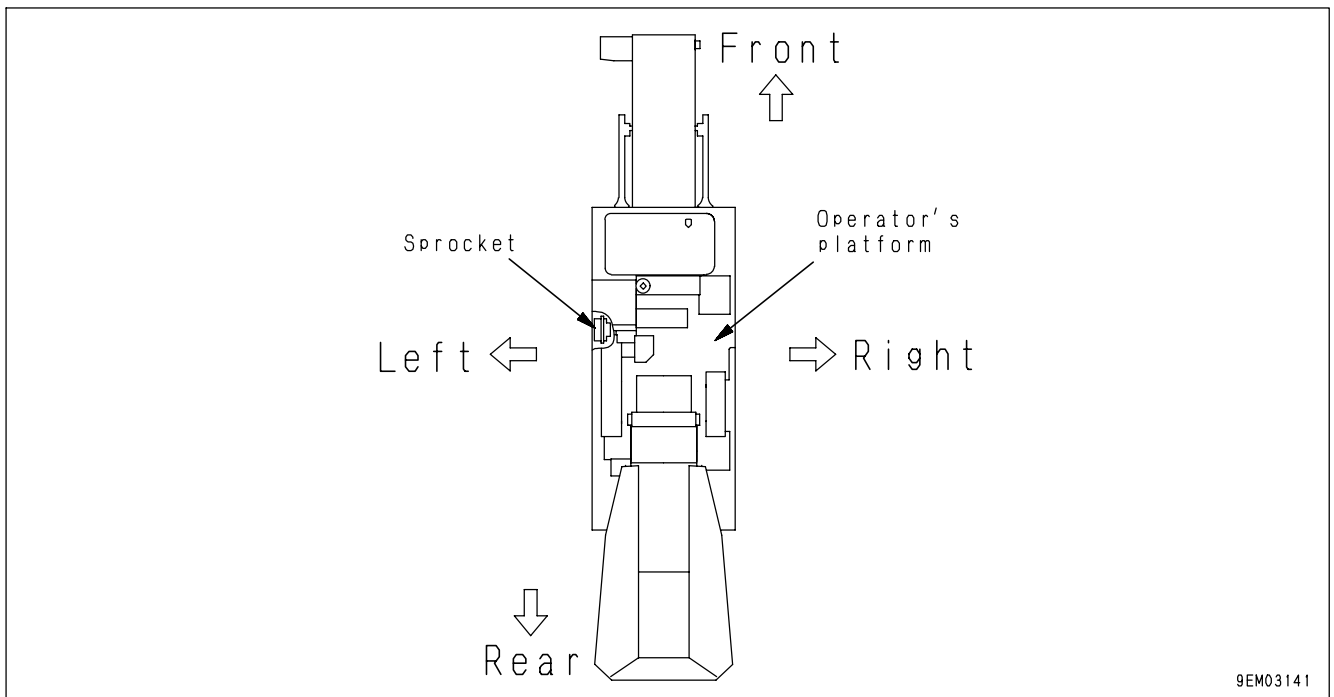

This manual indicates the right and left as well as the fore and aft sides of the machine, as viewed from the operator's platform in the forward traveling direction and with the sprockets turned to the front side.

NECESSARY INFORMATION

When requesting service or ordering replacement parts, please inform your Komatsu distributor of the following items.

MACHINE SERIAL NO. PLATE AND POSITION

Provided at the rear on the right side of the frame.

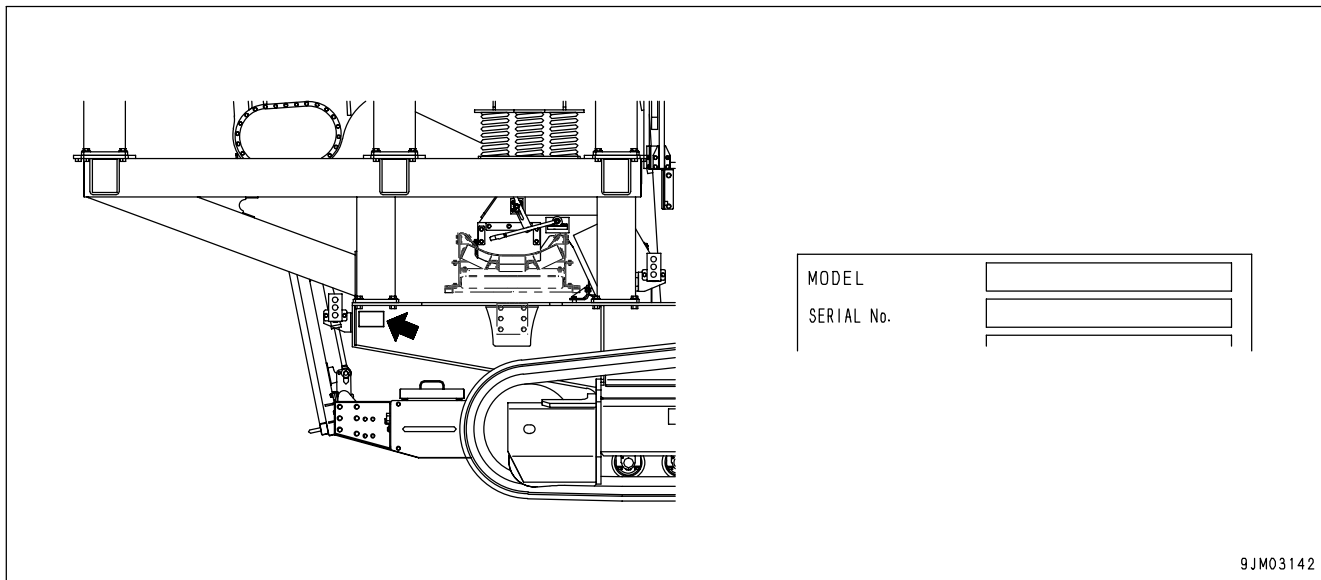

ENGINE SERIAL NO. PLATE AND POSITION

Provided at the side of the engine cylinder head cover (under the suction manifold).

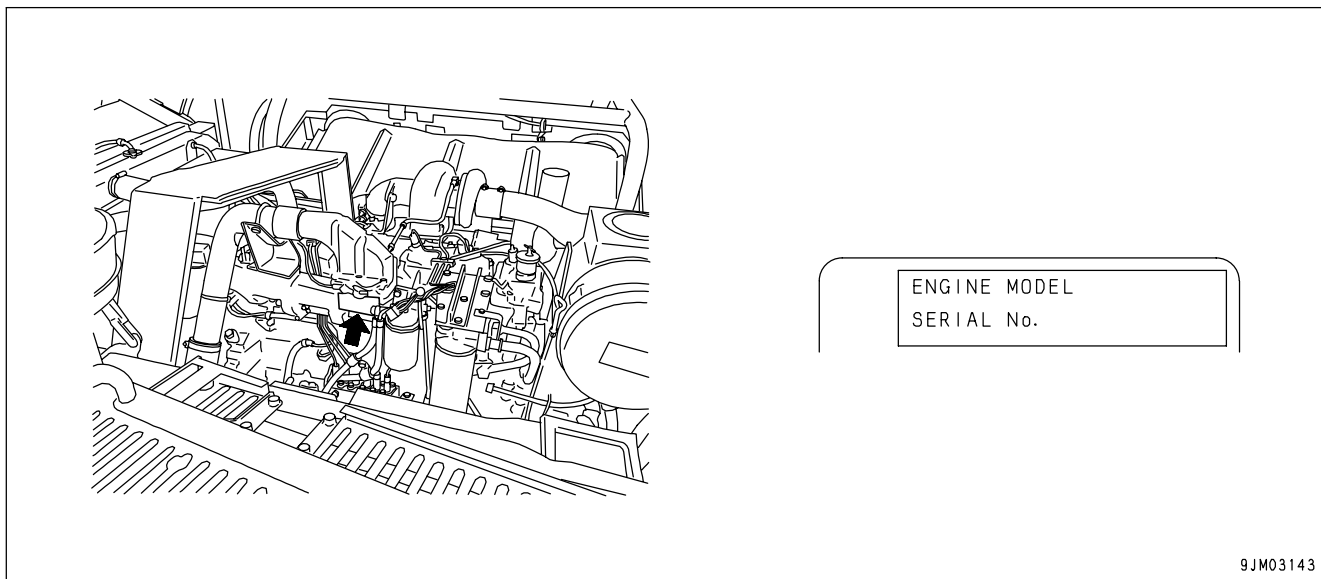

POSITION OF SERVICE METER

Provided above the machine monitors on the control panel.

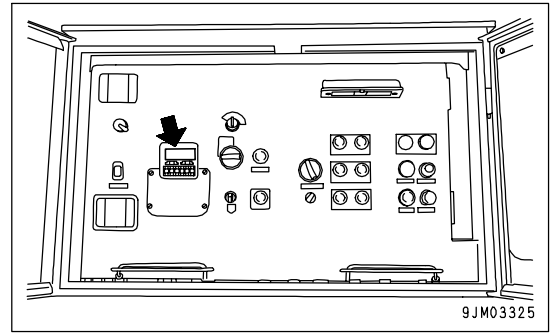

TABLE OF ENTER SERIAL NO. AND DISTRIBUTOR

Machine serial No.	
Engine serial No.	
Distributor name	
Address	-----

Service Personnel	
Phone/Fax	-----

CONTENTS

FOREWORD	1- 1
FOREWORD	1- 2
SAFETY INFORMATION	1- 5
INTRODUCTION	1- 7
FRONT/REAR, LEFT/RIGHT DIRECTIONS OF MACHINE	1- 7
NECESSARY INFORMATION	1- 8
MACHINE SERIAL NO. PLATE AND POSITION	1- 8
ENGINE SERIAL NO. PLATE AND POSITION	1- 8
POSITION OF SERVICE METER	1- 9
TABLE OF ENTER SERIAL NO. AND DISTRIBUTOR	1- 9
SAFETY	2- 1
SAFETY	2- 2
SAFETY LABELS	2- 5
POSITIONS OF SAFETY PICTOGRAMS	2- 6
SAFETY LABELS	2- 7
GENERAL PRECAUTIONS	2- 12
PRECAUTIONS FOR OPERATION	2- 19
STARTING ENGINE	2- 19
OPERATION	2- 21
CRUSHING OPERATION	2- 24
TRANSPORTATION	2- 27
BATTERY	2- 28
TOWING	2- 30
PRECAUTIONS FOR MAINTENANCE	2- 31
OPERATION	3- 1
GENERAL VIEW	3- 2
GENERAL VIEW OF MACHINE	3- 2
GENERAL VIEW OF CONTROLS AND GAUGES	3- 3
EXPLANATION OF COMPONENTS	3- 5
MACHINE MONITOR	3- 5
SWITCHES	3- 16
CONTROL LEVERS	3- 25
OPTION-RELATED SWITCHES	3- 26
CAP, COVER WITH LOCK	3- 27
REVOLVING WARNING LAMP	3- 29
ADDITIONAL WORKING LAMP	3- 30
FUSIBLE LINK	3- 30
CONTROLLERS	3- 31
FUSE	3- 31
TOOL BOX	3- 32
OPERATION	3- 33
CHECK BEFORE STARTING ENGINE	3- 33
STARTING ENGINE	3- 49
OPERATIONS AND CHECKS AFTER STARTING ENGINE	3- 52
STOPPING ENGINE	3- 54
CHECK AFTER STOPPING ENGINE	3- 54
MACHINE OPERATION	3- 55
STEERING MACHINE	3- 59
OPERATION OF WORK EQUIPMENT	3- 61

WATER SPRINKLER	3- 66
OPENING-CLOSING TYPE HOPPER	3- 67
CHECK AND CONFIRMATION OF JAW CRUSHER AFTER WORK	3- 75
CHECK AFTER FINISHING WORK	3- 75
LOCKING	3- 75
RUN-IN OPERATION OF JAW CRUSHER	3- 76
PRECAUTIONS WHEN OPERATING JAW CRUSHER	3- 79
EFFICIENT USE OF JAW CRUSHER	3- 81
SCOPE OF WORKS USING MOBILE CRUSHER	3- 86
PROHIBITIONS FOR OPERATION	3- 92
PRECAUTIONS WHEN TRAVELING UP OR DOWNHILLS	3- 94
TRANSPORTATION	3- 95
TRANSPORTATION PROCEDURE	3- 95
PROCEDURE FOR DISASSEMBLY AND FOLDING	3- 97
LOADING, UNLOADING WORK	3- 99
LIFTING MACHINE	3-106
COLD WEATHER OPERATION	3-107
PRECAUTIONS FOR LOW TEMPERATURE	3-107
AFTER COMPLETION OF WORK	3-108
AFTER COLD WEATHER	3-108
LONG-TERM STORAGE	3-110
BEFORE STORAGE	3-110
DURING STORAGE	3-110
AFTER STORAGE	3-110
STARTING MACHINE AFTER LONG-TERM STORAGE	3-110
TROUBLESHOOTING	3-111
PHENOMENA THAT ARE NOT FAILURES	3-111
METHOD OF TOWING MACHINE	3-111
IF BATTERY IS DISCHARGED	3-112
OTHER TROUBLE	3-115
MAINTENANCE	4- 1
GUIDE TO MAINTENANCE	4- 2
OUTLINE OF SERVICE	4- 4
HANDLING OIL, FUEL, COOLANT, AND PERFORMING OIL CLINIC	4- 4
RELATING TO ELECTRIC SYSTEM	4- 7
OUTLINE OF HYDRAULIC EQUIPMENT	4- 7
AIR-BLEEDING FROM HYDRAULIC CIRCUIT	4- 8
WEAR PARTS	4- 9
WEAR PARTS LIST	4- 9
JAW CRUSHER RELATED PARTS	4- 10
PRIMARY CONVEYOR RELATED PARTS	4- 12
USE OF FUEL, COOLANT AND LUBRICANTS ACCORDING TO AMBIENT TEMPERATURE	4- 14
STANDARD TIGHTENING TORQUES FOR BOLTS AND NUTS	4- 18
CRUSHER ACCESSORY TOOLS	4- 18
TORQUE LIST	4- 20
PERIODIC REPLACEMENT OF SAFETY CRITICAL PARTS	4- 21
SAFETY CRITICAL PARTS	4- 21
MAINTENANCE SCHEDULE CHART	4- 22
MAINTENANCE SCHEDULE CHART	4- 22
SERVICE PROCEDURE	4- 24

INITIAL 250 HOURS MAINTENANCE (ONLY AFTER THE FIRST 250 HOURS)	4- 24
WHEN REQUIRED	4- 25
CHECK BEFORE STARTING	4- 59
EVERY 100 HOURS SERVICE	4- 60
EVERY 250 HOURS SERVICE	4- 62
EVERY 500 HOURS SERVICE	4- 69
EVERY 1000 HOURS SERVICE	4- 74
EVERY 2000 HOURS SERVICE	4- 79
EVERY 4000 HOURS SERVICE	4- 81
EVERY 5000 HOURS SERVICE	4- 82
SPECIFICATIONS	5- 1
SPECIFICATIONS	5- 2
ATTACHMENTS, OPTIONS	6- 1
GENERAL PRECAUTIONS	6- 2
PRECAUTIONS RELATED TO SAFETY	6- 2
HYDRAULIC TYPE MAGNETIC SELECTOR	6- 3
SAFETY PRECAUTIONS	6- 3
PROCEDURES FOR CONNECTION WITH CRUSHER	6- 3
PRECAUTIONS IN USE	6- 3
CHECK AND INSPECTION	6- 4
FAILURES AND CORRECTIVE ACTIONS	6- 5
LIST OF CHECKPOINT	6- 5
SPECIFICATIONS	6- 6
LIST OF WEARING PARTS	6- 7
MUCK DISCHARGE CONVEYOR	6- 8
LIFTING PROCEDURES	6- 8
ASSEMBLING PROCEDURES	6- 9
PROCEDURES FOR FOLDING DEBRIS DISCHARGING CONVEYOR	6- 10
GREASING MUCK DISCHARGE CONVEYOR	6- 11
CHECK AND ADJUSTMENT OF MUCK DISCHARGE CONVEYOR	6- 12
FAILURES AND CORRECTIVE ACTIONS	6- 14
WEARING PARTS	6- 16
SPECIFICATIONS	6- 18
RADIO CONTROL UNIT	6- 19
DIRECTIONS FOR USE	6- 19
OVERVIEW	6- 21
ON USE OF RADIO CONTROL UNIT	6- 22
BELT CONVEYOR PROTECTIVE PLATE	6- 26
PROCEDURES FOR CONNECTING OPTIONAL ATTACHMENTS	6- 27
LOCATION OF PORTS FOR CONNECTING OPTIONAL ATTACHMENTS	6- 27
PROCEDURES FOR CONNECTING OPTIONAL ATTACHMENTS	6- 28
INDEX	7- 1

SAFETY

WARNING

Please read and make sure that you fully understand the precautions described in this manual and the safety labels on the machine. When operating or servicing the machine, always follow these precautions strictly.

SAFETY

SAFETY LABELS	2- 5
POSITIONS OF SAFETY PICTOGRAMS	2- 6
SAFETY LABELS	2- 7
GENERAL PRECAUTIONS	2- 12
SAFETY RULES	2- 12
IF ABNORMALITIES ARE FOUND	2- 12
CLOTHING AND PERSONAL PROTECTIVE ITEMS	2- 12
FFIRE EXTINGUISHER AND FIRST AID KIT	2- 12
SAFETY FEATURES	2- 12
KEEP MACHINE CLEAN	2- 13
ON OPERATOR'S PLATFORM	2- 13
ALWAYS APPLY LOCK WHEN LEAVING OPERATOR'S PLATFORM	2- 13
HANDRAILS AND STEPS	2- 14
MOUNTING AND DISMOUNTING	2- 14
NO PEOPLE ON ATTACHMENTS	2- 14
PREVENTION OF BURNS	2- 15
FIRE PREVENTION	2- 15
ACTION IF FIRE OCCURS	2- 16
PRECAUTIONS FOR ATTACHMENTS	2- 16
UNAUTHORIZED MODIFICATION	2- 16
SAFETY AT WORKSITE	2- 17
WORKING ON LOOSE GROUND	2- 17
DO NOT GO CLOSE TO HIGH-VOLTAGE CABLES	2- 17
ENSURE GOOD VISIBILITY	2- 18
VENTILATION FOR ENCLOSED AREAS	2- 18
CHECKING SIGNALMAN'S SIGNALS AND SIGNS	2- 18
BE CAREFUL ABOUT ASBESTOS DUST	2- 18

PRECAUTIONS FOR OPERATION	2- 19
STARTING ENGINE	2- 19
CHECKS BEFORE STARTING ENGINE	2- 19
PRECAUTIONS WHEN STARTING	2- 19
PRECAUTIONS IN COLD AREAS	2- 22
OPERATION	2- 21
CHECK BEFORE OPERATION	2- 21
PRECAUTIONS WHEN CHANGING DIRECTION	2- 21
PRECAUTIONS WHEN TRAVELING	2- 21
TRAVELING ON SLOPES	2- 22
PRECAUTIONS WHILE IN OPERATION	2- 22
OPERATE CAREFULLY ON SNOW	2- 22
PARKING MACHINE	2- 23
CRUSHER OPERATION	2- 24
CHECKS AROUND MACHINE	2- 24
TURN OPERATION MODE SELECTOR SWITCH TO WORK POSITION	2- 24
ENSURE SAFETY WHILE OPERATING IN TANDEM WITH HYDRAULIC EXCAVATOR	2- 24
CHECKS OF CRUSHER BEFORE STARTING OPERATION	2- 25
PRECAUTIONS FOR CRUSHING WORK	2- 25
EMERGENCY STOP TO WARD OFF DANGERS WHILE IN CRUSHING WORK	2- 26
TRANSPORTATION	2- 27
LOADING AND UNLOADING	2- 27
SHIPPING	2- 27
BATTERY	2- 28
BATTERY HAZARD PREVENTION	2- 28
STARTING WITH BOOSTER CABLE	2- 29
TOWING	2- 30
WHEN TOWING	2- 30

PRECAUTIONS FOR MAINTENANCE	2- 31
WARNING TAG	2- 31
KEEP WORK PLACE CLEAN AND TIDY	2- 31
APPOINT LEADER WHEN WORKING WITH OTHERS	2- 31
STOP ENGINE BEFORE CARRYING OUT INSPECTION AND MAINTENANCE	2- 31
TWO WORKERS FOR MAINTENANCE WHEN ENGINE IS RUNNING	2- 32
PRECAUTIONS FOR CONVEYOR MAINTENANCE	2- 32
PROPER TOOLS	2- 33
PERSONNEL	2- 33
PRECAUTIONS WHEN MOUNTING, DISMANTLING AND STORING ATTACHMENTS	2- 33
PRECAUTIONS FOR WORK UNDER MACHINEEQUIPMENT	2- 33
NOISE	2- 33
PRECAUTIONS WHEN USING HAMMER	2- 34
REPAIR WELDING	2- 34
REMOVING BATTERY TERMINAL	2- 34
PRECAUTIONS WHEN USING HIGH-PRESSURE GREASE TO ADJUST TRACK TENSION	2- 34
DO NOT DISASSEMBLE RECOIL SPRING	2- 34
PRECAUTIONS WITH HIGH-PRESSURE OIL	2- 35
HANDLING HIGH-PRESSURE HOSES	2- 35
WASTE MATERIAL	2- 35
COMPRESSED AIR	2- 35
PERIODIC REPLACEMENT OF SAFETY CRITICAL PARTS	2- 36

SAFETY LABELS

The following warning signs and safety labels are used on this machine.

- Be sure that you fully understand the correct position and content of labels.
- To ensure that the content of labels can be read properly, be sure that they are in the correct place and always keep them clean. When cleaning them, do not use organic solvents or gasoline. These may cause the labels to peel off.
- There are also other labels in addition to the warning signs and safety labels. Handle those labels in the same way.
- If the labels are damaged, lost, or cannot be read properly, replace them with new ones. For details of the part numbers for the labels, see this manual or the actual label, and place an order with Komatsu distributor.

POSITIONS OF SAFETY PICTOGRAMS

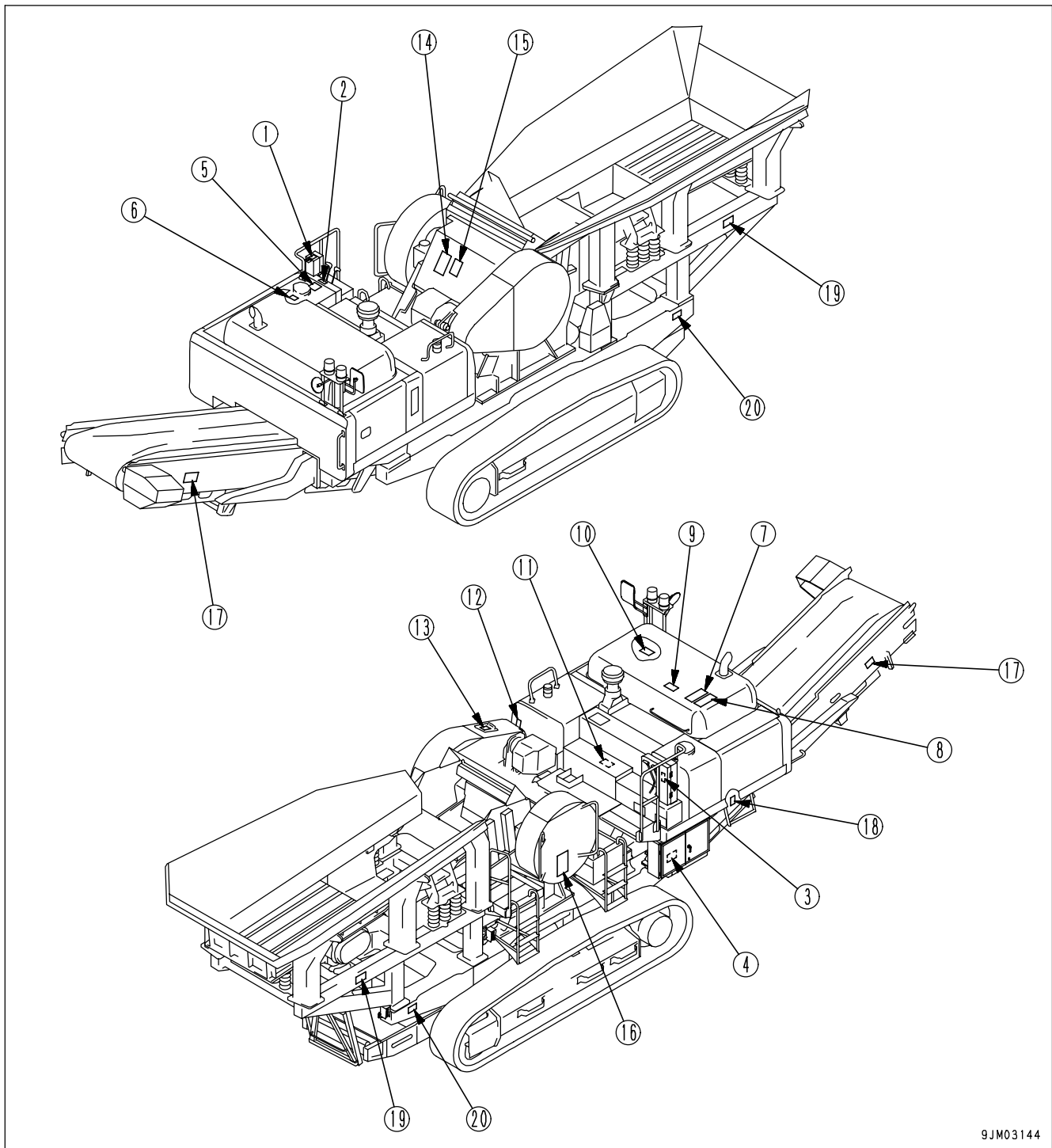

9JM03144

SAFETY LABELS

(1)Precautions when leaving the operator's platform
(8295-93-1371)



There is the hazard that the machine may move suddenly and catch on or run over someone near the machine, causing an injury.

Be sure to put the travel control lever in the LOCK position, whenever leaving the operator's platform.

(2)Watch out electric wires (8295-93-1580)



If the machine goes close to high-voltage wires, it will result in an electric shock to the operator.

Maintain a safe distance between the machine and the electric wires. (See SAFETY section, in this manual)

(3)Precautions for machine operation, inspection and maintenance (09651-A0481)

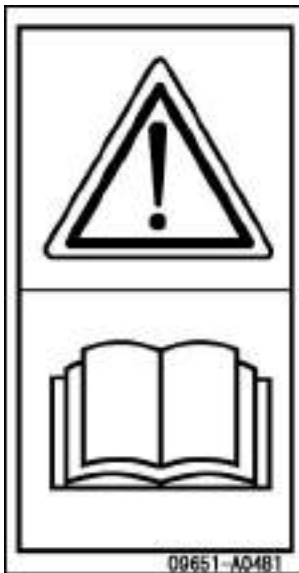

Warning !

Read manual before operation, maintenance, disassembly, assembly and transportation.

(4)Precautions for machine operation, inspection and maintenance (09651-A0461)

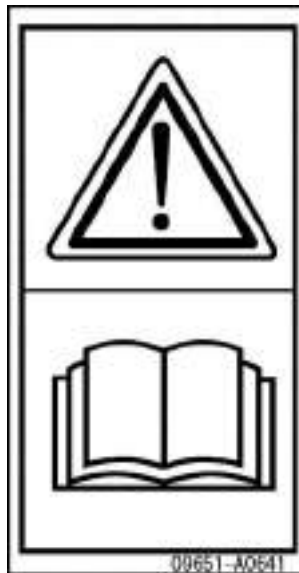

Warning !

Read manual before operation, maintenance, disassembly, assembly and transportation.

(5) Warning when operating the machine
(8221-93-1611)



(6) Precautions for oil at high temperature
(09653-A0641)



Sign indicates a burn hazard from spurting hot water or oil if radiator or hydraulic tank is uncapped while hot.

Allow radiator or hydraulic tank to cool before removing cap.

(7) Warning the machine operator against falling off the machine (09805-C0881)



Sign indicates a hazard of falling.

Do not stand on this place here.

(8) Warning against machine rolling down (09805-A0881)



There is the hazard of falling down.

Do not go close to the edge of the machine by mistake.

(9)Precautions for the engine while running(09667-A0481)



Sign indicates a hazard of rotating parts, such as belt.

Turn off before inspection and maintenance.

(10)Precautions for the cooling water at high temperature(09653-A0481)



Never remove the cap when the engine is at operating (high) temperature. Stream or high temperature oil blowing up from the radiator or hydraulic tank, will cause personal injury and/or burns.

Never remove the radiator cap or hydraulic tank oil filler when cooling water or hydraulic oil is at high temperatures.

(11)Precautions when handling electric cables (09808-A0881)

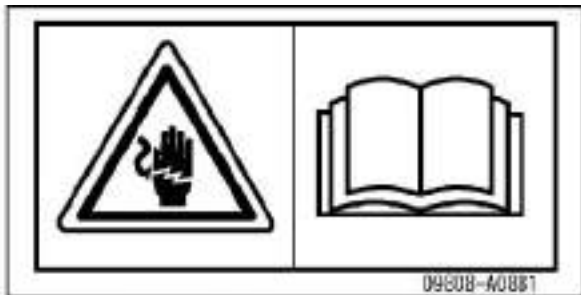

Sign indicates an electric hazard from handling the cable. Read manual for safe and proper handling.

(12)Warning when climbing up and down the machine (8248-93-1440)



(13) Warning when inspecting the crusher pulley(09667-A0641)

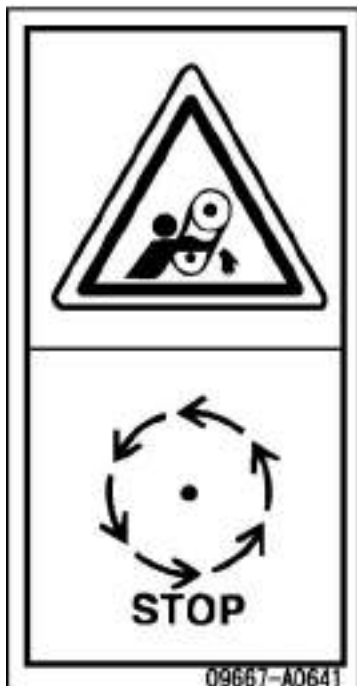

Sign indicates a hazard of rotating parts, such as belt.

Turn off before inspection and maintenance.

(14) Precautions when inspecting the crusher (09838-H1201)



Sign indicates a crush hazard between the jaws of the jaw crusher.

Keep away from hopper during operation.

(15) Warning against spattering debris (09826-A0881)



Crushed debris pieces may fly off from within the crusher, causing an injury to those in the vicinity.

Do not get close to the crusher, while in operation.

(16) Prohibition of unauthorized entry into Off-Limit working area (09829-H1681)



Sign indicates a hazard of falling rock and objects.

Keep away from conveyor during operation.

(17) Warning against danger around the operating belt conveyor (09828-H2321)

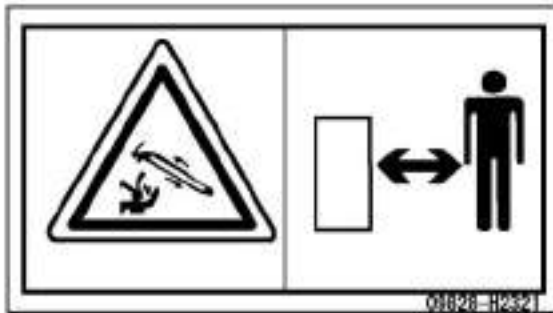

Sign indicates a hazard of falling rock and objects.

Keep away from conveyor during operation.

(18) Warning when inspecting the belt conveyor (09667-A0641)

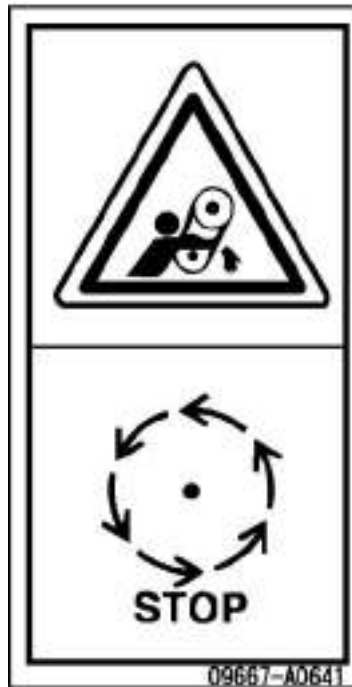

Sign indicates a hazard of rotating parts, such as belt.

Turn off before inspection and maintenance.

(19) Precautions for access to the grizzly while in operation (09834-H1201)



Sign indicates a hazard of being hit by vibrating feeder or sieve.

Keep away from hopper during operation.

(20) Precautions when tightening the track shoe tension (09657-A0881)



Sign indicates a hazard of flying plug from track adjuster that could cause injury.

Read manual and adjusting track for safe and proper handling.

GENERAL PRECAUTIONS

SAFETY RULES

- Only trained and authorized personnel can operate and maintain the machine.
- Follow all safety rules, precautions and instructions when operating or performing maintenance on the machine.
- If you are under the influence of alcohol or medication, your ability to safely operate or repair your machine may be severely impaired putting yourself and everyone else on your jobsite in danger.
- When working with another operator or with a person on worksite traffic duty, be sure that all personnel understand all hand signals that are to be used.

IF ABNORMALITIES ARE FOUND

If you find any problems in the machine during operation or maintenance (noise, vibration, smell, incorrect gauges, smoke, oil leakage, etc., or any abnormal display on the warning devices or monitor), report to the person in charge and have the necessary action taken. Do not operate the machine until the problem has been corrected.

CLOTHING AND PERSONAL PROTECTIVE ITEMS

- Do not wear loose clothing and accessories. There is a hazard that they may catch on control levers or other protruding parts.
- If you have long hair and it hangs out from your hard hat, there is a hazard that it may get caught up in the machine, so tie your hair up and be careful not to let it get caught.
- Always wear a hard hat and safety shoes. If the nature of the work requires it, wear safety glasses, mask, gloves, ear plugs, and safety belt when operating or maintaining the machine.
- Check that all protective equipment functions properly before using it.

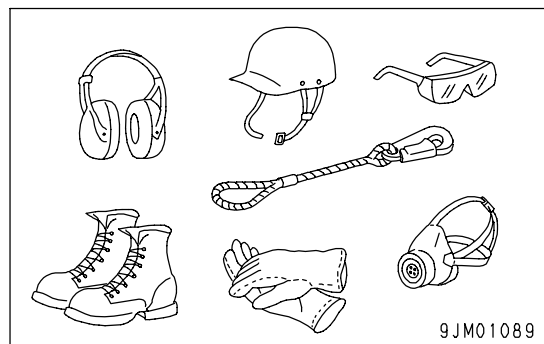

FIRE EXTINGUISHER AND FIRST AID KIT

Always follow the precautions below to prepare for action if any injury or fire should occur.

- Be sure that fire extinguishers have been provided and read the labels to ensure that you know how to use them in emergencies.
- Carry out periodic inspection and maintenance to ensure that the fire extinguisher can always be used.
- Provide a first aid kit at the storage point. Carry out periodic checks and add to the contents if necessary.

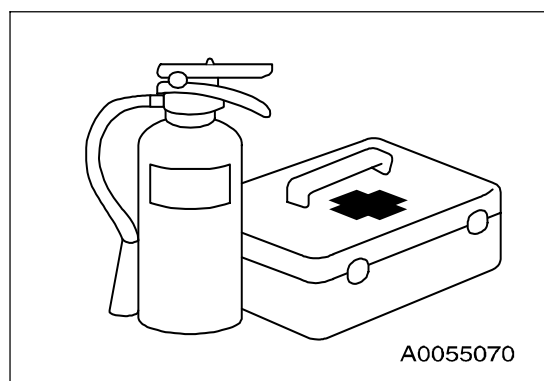

SAFETY FEATURES

- Be sure that all guards and covers are in their proper position. Have guards and covers repaired immediately if they are damaged.
- Understand the method of use of safety features and use them properly.
- Never remove any safety features. Always keep them in good operating condition.

KEEP MACHINE CLEAN

- If water gets into the electrical system, there is a hazard that it will cause malfunctions or misoperation. Do not use water or steam to wash the electrical system (sensors, connectors).
- If inspection and maintenance is carried out when the machine is still dirty with mud or oil, there is a hazard that you will slip and fall, or that dirt or mud will get into your eyes. Always keep the machine clean.

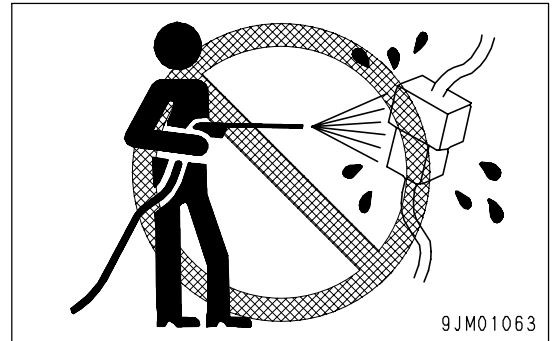

ON OPERATOR'S PLATFORM

- Wipe out oil, grease and mud stuck to shoe soles before getting on the machine. If you get on the machine without them being wiped out, you will likely slip off and suffer a serious accident.
- Make sure that no parts or tools are left around the operator's platform.
- Never use a cellular phone on the operator's platform, while operating the machine.
- Never place any dangerous material like inflammables or explosives around the operator's platform.

ALWAYS APPLY LOCK WHEN LEAVING UPPER OPERATION DECK

- When leaving the upper operation deck for starting the work after traveling and setting the machine, be sure to place the travel lever safety lock at the LOCK position. If you touch the travel lever carelessly, the machine may start travelling suddenly, and this may cause serious injury or death.

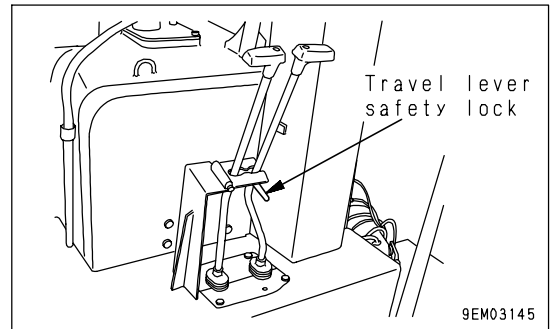

- When the work is completed, be sure to set Travel/Work Switch (A) to the "Work" position, stop the engine and then shut all the locks. Never forget to pull off the key and take it away with you to keep it in the specified place.

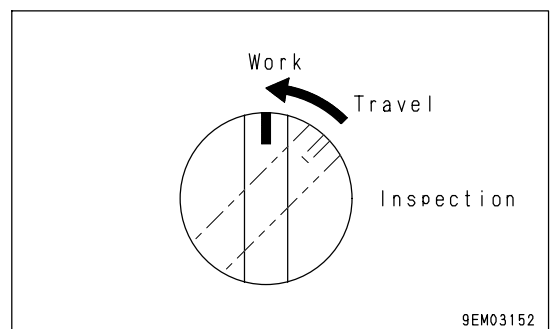
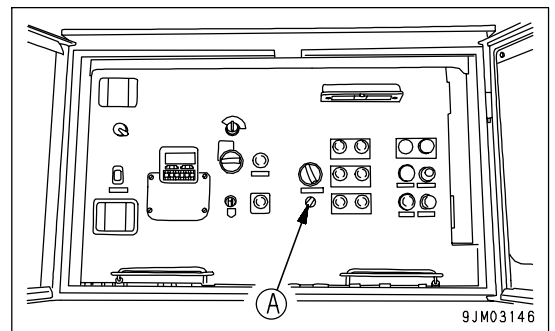

HANDRAILS AND STEPS

To prevent personal injury caused by slipping or falling off the machine, always do as follows.

- Use the handrails and steps marked by arrows in the diagram on the right when getting on or off the machine.

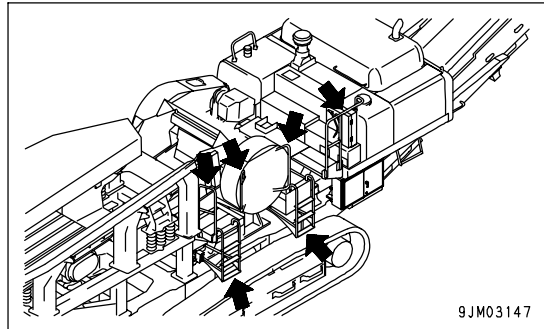

- To ensure safety, always face the machine and maintain three-point contact (both feet and one hand, or both hands and one foot) with the handrails and steps (including the track shoe) to ensure that you support yourself.
- Never climb on the engine hood or covers where there are no non-slip pads.
- Before getting on or off the machine, check the handrails and steps (including the track shoe). If there is any oil, grease, or mud on the handrails or steps (including the track shoe), wipe it off immediately. Always keep these parts clean. Repair any damage and tighten any loose bolts.
- Do not get on or off the machine while holding tools in your hand.

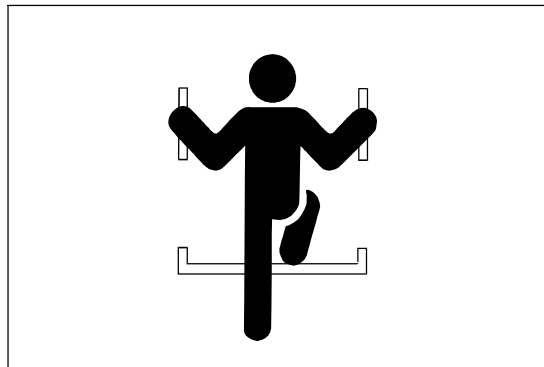
**MOUNTING AND DISMOUNTING**

- Never jump on or off the machine. Never get on or off a moving machine.
- If the machine starts to move when there is no operator on the machine, do not jump on to the machine and try to stop it.

NO PEOPLE ON ATTACHMENTS

Never let anyone ride on the work equipment, or other attachments. There is a hazard of falling and suffering serious injury.

PREVENTION OF BURNS**Hot coolant**

- To prevent burns from hot water or steam spurting out when checking or draining the coolant, wait for the water to cool to a temperature where it is possible to touch the radiator cap by hand before starting the operation. Even when the coolant has cooled down, loosen the cap slowly to relieve the pressure inside the radiator before removing the cap.

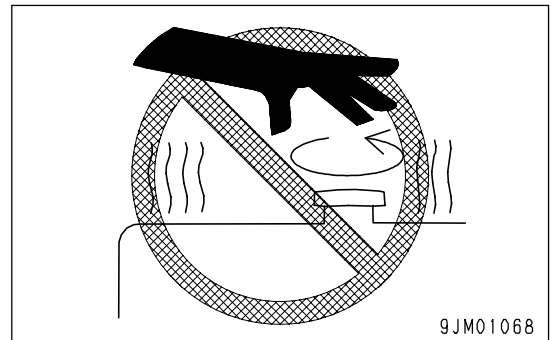
**Hot oil**

- To prevent burns from hot oil spurting out when checking or draining the oil, wait for the oil to cool to a temperature where it is possible to touch the cap or plug by hand before starting the operation. Even when the oil has cooled down, loosen the cap or plug slowly to relieve the internal pressure before removing the cap or plug.

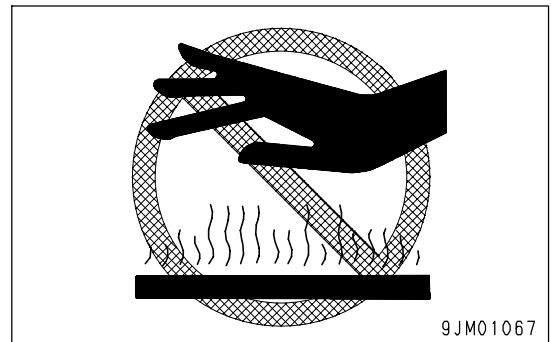
**FIRE PREVENTION**

- **Fire Prevention for Fuel and Oil**

Fuel, oil and antifreeze can be ignited by a flame. Be sure to follow the instructions given below without fail.

- Never smoke nor use fire near any of them.
- Stop the engine for refuelling and oiling.
- Never leave the machine, while refueling or oiling.
- Tighten all the fuel and oil caps securely.
- Do not spill fuel on the heated engine parts or electrical parts.
- Keep fuel and oil in a well ventilated place.
- Keep fuel and oil in the determined place and do not allow unauthorized persons to enter.
- Wipe out the spillage after fuel, oil and grease are added.
- When machining or welding any machine parts, move away inflammables and keep them in a safe place beforehand.
- When cleaning parts, do not use inflammable oil such as light oil and gasoline for cleaning, but use nonflammable oil.
- Inflammables like cloth wet with oil should be placed in a safe container and kept in a safe place.
- Do not try to weld or gas-cut piping or tubes containing inflammable liquid.



- **Fire caused by accumulation of flammable material.**

Remove any dry leaves, chips, pieces of paper, dust, or any other flammable materials accumulated or affixed around the engine, exhaust manifold, muffler, or battery, or inside the undercovers.

- **Fire coming from electric wiring**

Short circuits in the electrical system can cause fire.

- Always keep electric wiring connections clean and securely tightened.
- Check the wiring every day for looseness or damage. Tighten any loose connectors or wiring clamps. Repair or replace any damaged wiring.

- **Fire coming from hydraulic line**

Check that all the hose and tube clamps, guards, and cushions are securely fixed in position.

If they are loose, they may vibrate during operation and rub against other parts. This may lead to damage to the hoses, and cause high-pressure oil to spurt out, leading to fire damage or serious injury.

- **Use of Anti-explosion Type Lighting**

- When checking the fuel, oil, coolant and battery electrolyte levels, use a lighting apparatus of anti-explosion specification. If a lighting apparatus without anti-explosion specification is used, there will be a danger that they catch fire and explode, causing a serious injury or death.

ACTION IF FIRE OCCURS

If a fire occurs, escape from the machine as follows.

- Turn the start switch OFF to stop the engine.
- Use the handrails and steps to get off the machine.

PRECAUTIONS FOR ATTACHMENTS

- When installing optional parts or attachments, there may be problems with safety or legal restrictions. Therefore contact your Komatsu distributor for advice.
- Any injuries, accidents, or product failures resulting from the use of unauthorized attachments or parts will not be the responsibility of Komatsu.
- When installing and using optional attachments, read the instruction manual for the attachment, and the general information related to attachments in this manual.

UNAUTHORIZED MODIFICATION

Any modification made without authorization from Komatsu can create hazards. Before making a modification, consult your Komatsu distributor.

- Komatsu will not be responsible for any injuries, accidents, product failures or other property damages resulting from modifications made without authorization from Komatsu.

SAFETY AT WORKSITE

Before starting operations, thoroughly check the area for any unusual conditions that could be dangerous.

- When carrying out operations near combustible materials such as thatched roofs, dry leaves or dry grass, there is a hazard of fire, so be careful when operating.
- Check the terrain and condition of the ground at the worksite, and determine the safest method of operation. Do not carry out operations at places where there is a hazard of landslides or falling rocks.
- If water lines, gas lines, or high-voltage electrical lines may be buried under the worksite, contact each utility and identify their locations. Be careful not to sever or damage any of these lines.
- Take action to prevent unauthorized people from approaching the jobsite.

When working on public roads, position flagmen and erect barriers to ensure the safety of passing traffic and pedestrians.

- When traveling or operating in shallow water or on soft ground, check the shape and condition of the bedrock, and the depth and speed of flow of the water before starting operations.

WORKING ON LOOSE GROUND

- Avoid traveling or operating your machine too close to the edge of cliffs, overhangs, and deep ditches. The ground may be weak in such areas. If the ground should collapse under the weight or vibration of the machine, there is a hazard that the machine may fall or tip over. Remember that the soil after heavy rain or blasting or after earthquakes is weak in these areas.
- When working on embankments or near excavated ditches, there is a hazard that the weight and vibration of the machine will cause the soil to collapse. Before starting operations, take steps to ensure that the ground is safe and to prevent the machine from rolling over or falling.

DO NOT GO CLOSE TO HIGH-VOLTAGE CABLES

Do not travel or operate the machine near electric cables. There is a hazard of electric shock, which may cause serious injury or property damage. On jobsites where the machine may go close to electric cables, always do as follows.

- Before starting work near electric cables, inform the local power company of the work to be performed, and ask them to take the necessary action.

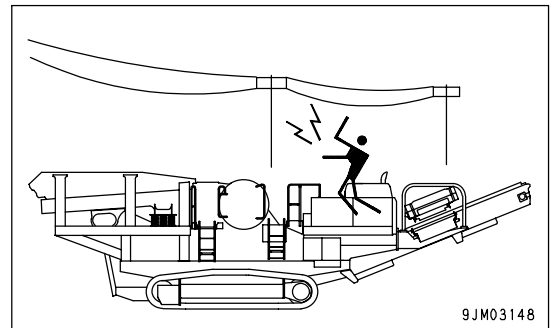

- Even going close to high-voltage cables can cause electric shock, which may cause serious burns or even death. Always maintain a safe distance (see the table on the right) between the machine and the electric cable. Check with the local power company about safe operating procedure before starting operations.
- Wear rubber-soled shoes and rubber gloves for fear of an electric shock and be careful that any unprotected body part will never touch the machine.
- Use a signalman to give warning if the machine approaches too close to the electric cables.
- When carrying out operations near high voltage cables, do not let anyone come close to the machine.
- Should the machine have got too close to an electric wire or come to contact with it, the operator must not leave the machine, but stay in the operator's platform, in order to avoid a risk of electric shock, until the electricity is switched off. Likewise do not allow anyone to come close to the machine.

Voltage of Cables	Safety Distance
100 V - 200 V	Over 2 m (7 ft)
6,600 V	Over 2 m (7 ft)
22,000 V	Over 3 m (10 ft)
66,000 V	Over 4 m (14 ft)
154,000 V	Over 5 m (17 ft)
187,000 V	Over 6 m (20 ft)
275,000 V	Over 7 m (23 ft)
500,000 V	Over 11 m (36 ft)

ENSURE GOOD VISIBILITY

- Check for any persons or obstacles in the area around the machine and check the conditions of the jobsite to ensure that operations and travel can be carried out safely. Always do as follows.
 - When working in dark places, turn on the working lamp and front lamps installed to the machine, and set up additional lighting in the work area if necessary.
 - Stop operations if the visibility is poor, such as in mist, snow, rain, or dust.

VENTILATION FOR ENCLOSED AREAS

Exhaust fumes from the engine can kill.

- If it is necessary to start the engine within an enclosed area, or when handling fuel, flushing oil, or paint, open the doors and windows to ensure that adequate ventilation is provided to prevent gas poisoning.

**CHECKING SIGNALMAN'S SIGNALS AND SIGNS**

- Set up signs to inform of road shoulders and soft ground. If the visibility is not good, position a signalman if necessary. Operators should pay careful attention to the signs and follow the instructions from the signalman.
- Only one signalman should give signals.
- Make sure that all workers understand the meaning of all signals and signs before starting work.

BE CAREFUL ABOUT ASBESTOS DUST

Asbestos dust in the air can cause lung cancer if it is inhaled. There is danger of inhaling asbestos when working on jobsites handling demolition work or work handling industrial waste. Always observe the following.

- Spray water to keep down the dust when cleaning. Do not use compressed air for cleaning.
- If there is danger that there may be asbestos dust in the air, always operate the machine from an upwind position. All workers should use an approved respirator.
- Do not allow other persons to approach during the operation.
- Always observe the rules and regulations for the work site and environmental standards.

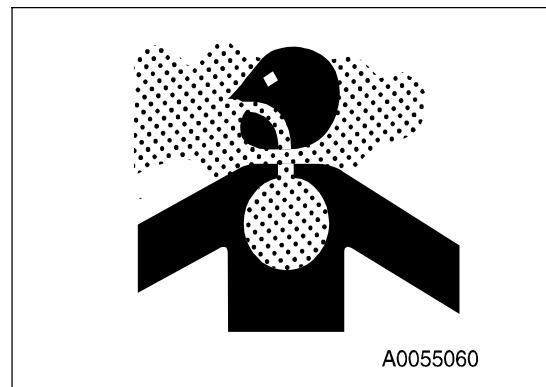

This machine does not use asbestos, but there is a danger that imitation parts may contain asbestos, so always use genuine Komatsu parts.

PRECAUTIONS FOR OPERATION

STARTING ENGINE

When a warning tag is attached to the engine starting switch, do not start the engine, nor touch the control levers.

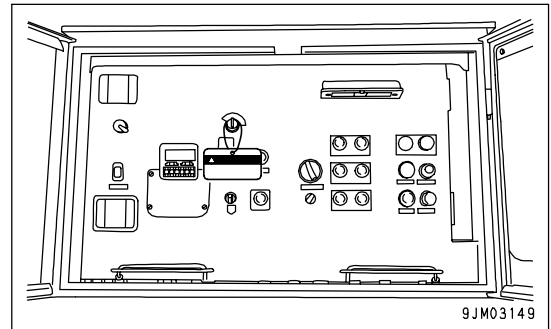

CHECKS BEFORE STARTING ENGINE

Carry out the following checks before starting the engine at the beginning of the day's work.

- Remove all dirt from the surface of the lens of the front lamps and working lamps, and check that they light up correctly.
- Check the coolant level, fuel level, and oil level in engine oil pan, check for clogging of the air cleaner, and check for damage to the electric wiring.
- Check that the gauges work properly, check the angle of the lights and working lamps, and check that the control levers are all at the neutral position.
- Before starting the engine, make sure that the lock lever is in the LOCK position.
- Adjust the position of the rear view mirror so that both sides and the rear part of the machine can be clearly seen from the operator's platform.
Refer to "ADJUSTMENT OF REAR VIEW MIRROR (PAGE 3-40)" for the position adjustment.
- Check that there are no persons or obstacles above, below, or in the area around the machine.

PRECAUTIONS WHEN STARTING

- When starting the engine, sound the horn as a warning.
- Start and operate the machine only while seated.
- Do not allow anyone apart from the operator to ride on the machine.
- Do not short circuit the starting motor circuit to start the engine. Short circuit can cause fire.

PRECAUTIONS IN COLD AREAS

- Carry out the warming-up operation thoroughly. If the machine is not thoroughly warmed up before the control levers are operated, the reaction of the machine will be slow, and this may lead to unexpected accidents.
- If the battery electrolyte is frozen, do not charge the battery or start the engine with a different power source. There is a hazard that this will ignite the battery and cause the battery to explode. Before charging or starting the engine with a different power source, melt the battery electrolyte and check that there is no leakage of electrolyte before starting.

OPERATION

CHECK BEFORE OPERATION

When carrying out the checks, move the machine to a wide area where there are no obstructions, and operate slowly. Do not allow anyone near the machine.

- Check that the work equipment, traveling device, etc. work properly.
- Check for any abnormality in the sound of the machine, vibration, heat, smell, or gauges; check also that there is no leakage of oil or fuel.
- If any abnormality is found, carry out repairs immediately.

PRECAUTIONS WHEN CHANGING DIRECTION

- Before travelling, check again that there is no one in the surrounding area, and that there are no obstacles.
- Before travelling, sound the horn to warn people in the area.
- Do not allow anyone apart from the operator to ride on the machine.
- Make sure that the travel alarm works properly.
- Post a signal person at the worksite, if there is a blind spot at the rear of the machine where the operator's view is blocked.

Always be sure to carry out the above precautions even when the machine is equipped with mirrors.

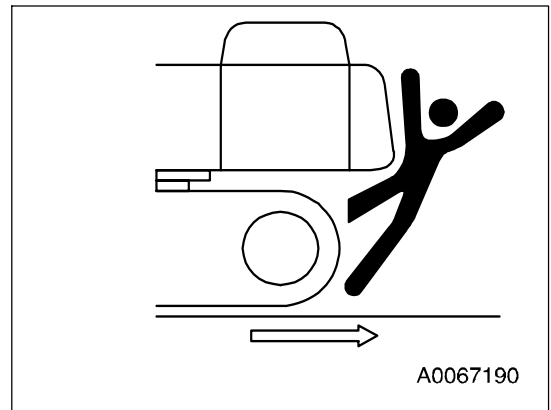

PRECAUTIONS WHEN TRAVELING

- On the uneven ground, operate the machine at a low speed, avoiding jerky operation, so that the machine will not roll over. Otherwise the machine might inflict a damage on the surrounding structures.
- Operate the machine with the hopper, crusher and belt conveyor empty.
- Try to avoid having the machine climb over obstacles. If that is unavoidable, let the machine do that at a low speed. Nonetheless avoid a big obstacle that greatly tilts the machine to the right or left, because in such a case the machine can easily overturn sideways.
- When traveling or carrying out operations, always keep a safe distance from people, structures, or other machines to avoid coming into contact with them.
- When passing over bridges or structures, check first that the structure is strong enough to support the weight of the machine. When traveling on public roads, check first with the relevant authorities and follow their instructions.
- When operating in tunnels, under bridges, under electric wires, or other places where the height is limited, operate slowly and be extremely careful not to let the work equipment hit anything.

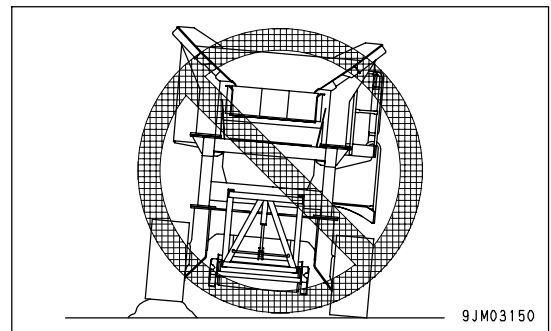

TRAVELING ON SLOPES

- When traveling downhill, lower the engine speed, keep the travel lever close to the neutral position, and travel at low speed.
- Always travel straight up or down a slope. Traveling at an angle or across the slope is extremely dangerous.
- Do not turn on slopes or travel across slopes. Always go down to a flat place to change the position of the machine, then travel on to the slope again.
- Travel on grass, fallen leaves, or wet steel plates with low speed. Even with slight slopes there is a hazard that the machine may slip.
- If the engine stops when the machine is traveling on a slope, move the control levers immediately to the neutral position and start the engine again.

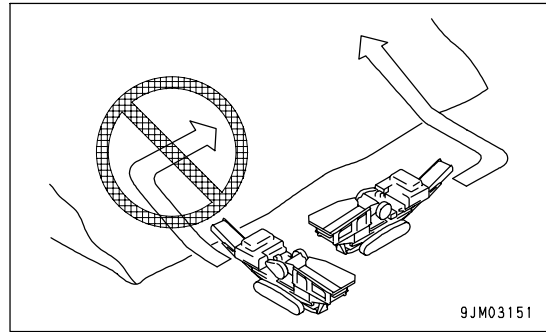
**PRECAUTIONS WHILE IN OPERATION**

- Park the machine on the even and solid ground for starting the work.
- When operating in tunnels, under bridges, under electric wires, or other places where the height is limited, be extremely careful not to let the work equipment hit anything.
- To prevent accidents caused by hitting other objects, always operate the machine at a speed which is safe for operation, particular in confined spaces, indoors, and in places where there are other machines.

OPERATE CAREFULLY ON SNOW

- Snow-covered or frozen surfaces are slippery, so be extremely careful when traveling or operating the machine, and do not operate the levers suddenly. Even a slight slope may cause the machine to slip, so be particularly careful when working on slopes.
- With frozen ground surfaces, the ground becomes soft when the temperature rises, and this may cause the machine to tip over.
- If the machine enters deep snow, there is a hazard that it may tip over or become buried in the snow. Be careful not to leave the road shoulder or to get trapped in a snow drift.

PARKING MACHINE

- Park the machine on firm, level ground.
- Select a place where there is no hazard of falling rocks or landslides, or of flooding if the land is low.
- When the machine is parked on a public road, put up a warning flag, a fence or any other caution sign as well as install an illumination system to the extent that they do not hinder the traffic, so that other ongoing vehicles can readily spot the machine.
- When parking the machine, be sure to set the travel lever safety lock to the LOCK position and stop the engine by turning the mode selector switch to the INSPECTION position.
- Shut all the locks on the machine and pull off the key so that an unauthorized person may not operate the machine without permission, and safe-keep it in the determined place.

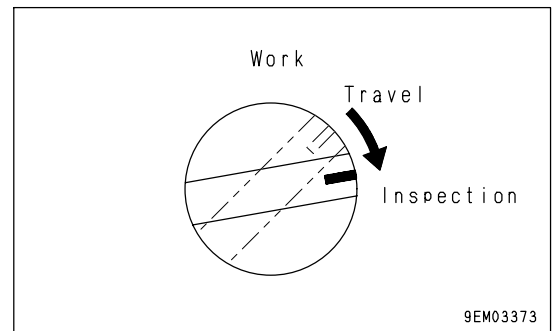
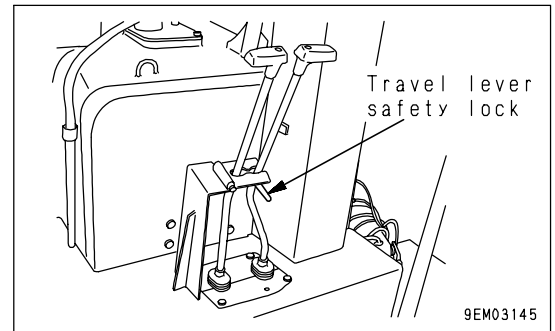

- When it becomes unavoidable to park the machine on a slope, follow the instructions below.
 - Place blocks at the end of the track shoes so that the machine will not slithers down.

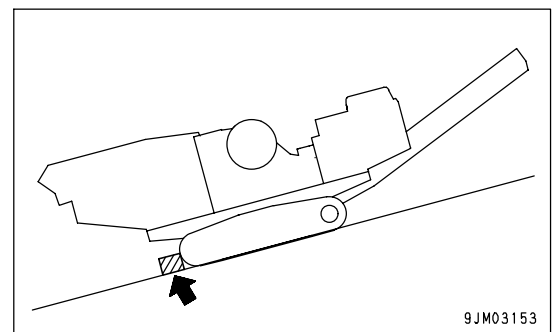

CRUSHING OPERATION

When carrying out an inspection and cleaning of the belt conveyor and the surroundings, stop the engine first and then start the work. There is always a danger that the service person might get caught in the revolving parts of the belt conveyor.

CHECKS AROUND MACHINE

- In consideration of the safety to the neighbourhood, put up a protective screen all around the machine.
- Crusher workers should wear protective glasses and a dust-proof respirator not to mention a hard hat.

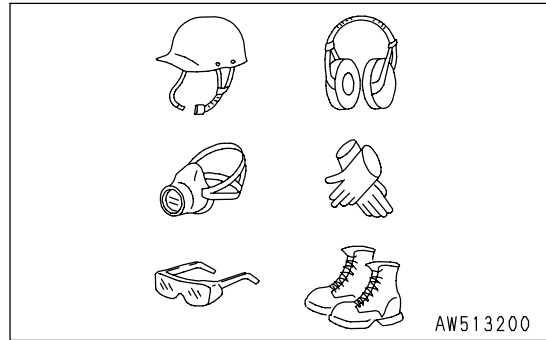

TURN MODE SELECTOR SWITCH TO WORK POSITION

- Set the travel lever safety lock to the LOCK position.

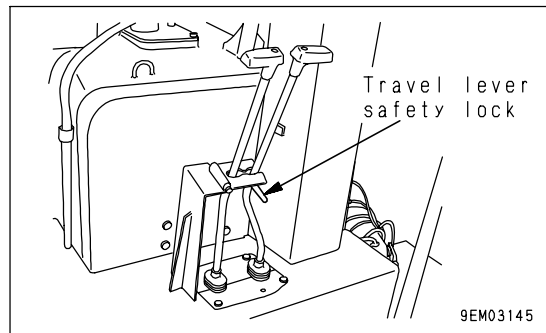

- After turning the mode selector switch to "Work" position, start the machine operation in accordance with the instructions set forth in the section of "Operation, Jaw crusher operation" in this manual.

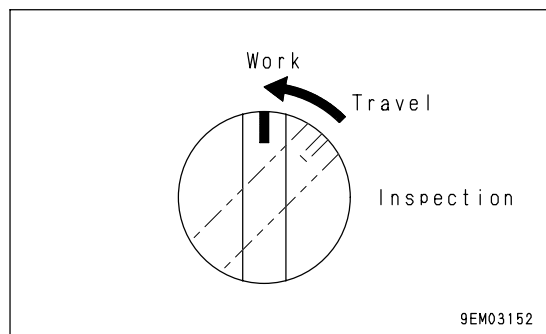

ENSURE SAFETY WHILE OPERATING IN TANDEM WITH HYDRAULIC EXCAVATOR

- The operator of this machine is supposed to work in cooperation with the operator of a loading machine like a hydraulic excavator or wheel loader. Hence, for the sake of mutual safety, it is recommended for them to determine common signals beforehand and to follow the advice below in particular.
- The operator of the loading machine should place his/her machine in such a place that allows him/her to keep in sight all of the interior of the hopper, workers at the hopper and the selector workers at the belt conveyor without fail.
- The operator of this machine is advised to take his/her stand from where the bucket and the operator of the loading machine can clearly be seen.
The next loading work should only be begun at a signal from the operator of this machine.

CHECKS OF CRUSHER BEFORE STARTING OPERATION

Before starting with crushing work, inspect the following to confirm that there is nothing abnormal with the machine.

- Check that there is no foreign material left inside the hopper and crusher.
- Check that each bolt is securely tightened.

In this case, pay special attention to the crusher mounting bolts, wedge bolts securing jaw plates and cheek plate securing bolts in particular.

- Check the machine main frame whether there is no deformation or crack developed on it.

PRECAUTIONS FOR CRUSHING WORK

- While the machine is in operation, do not allow any irrelevant person to come near the machine. There is always the danger that a flying crushed stone might hit him/her accidentally.
- When the crusher is in operation, do not put your face above the hopper.
- Even if the hopper is clogged, poke it with a bar or breaker under no circumstances.

When you have to work around the crusher, first stop the crusher and the engine, since there is the danger that you may be drawn into the crusher together with debris.

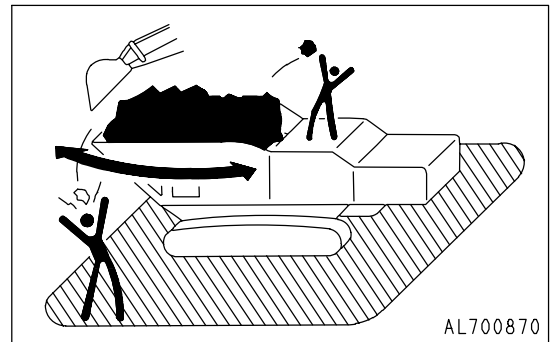

EMERGENCY STOP TO WARD OFF DANGERS WHILE IN CRUSHING WORK

- An operator of this machine must take position near the emergency stop switch during the work and immediately press the switch to stop all the work equipment, when he or she feels something abnormal about the machine or a danger of any kind.

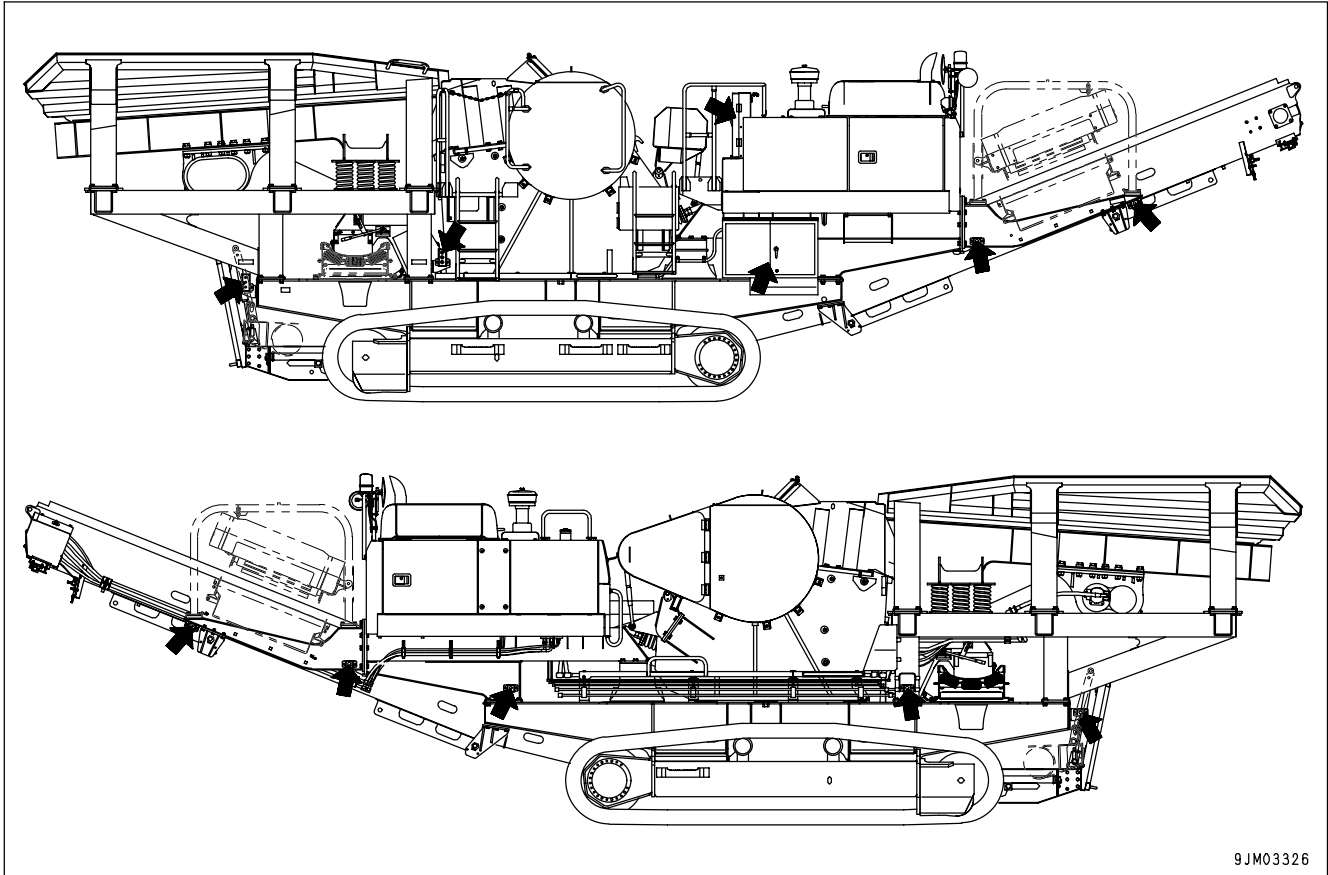

TRANSPORTATION

The machine can be divided into parts for transportation, so when transporting the machine, please contact your Komatsu distributor to have the work carried out.

LOADING AND UNLOADING

When loading or unloading the machine, mistaken operation may bring the hazard of the machine tipping over or falling, so particular care is necessary. Always do as follows.

- Perform loading and unloading on firm, level ground only. Maintain a safe distance from the edge of the road or cliff.
- Always use ramps of adequate strength. Be sure that the ramps are wide, long, and thick enough to provide a safe loading slope. Take suitable steps to prevent the ramps from moving out of position or coming off.

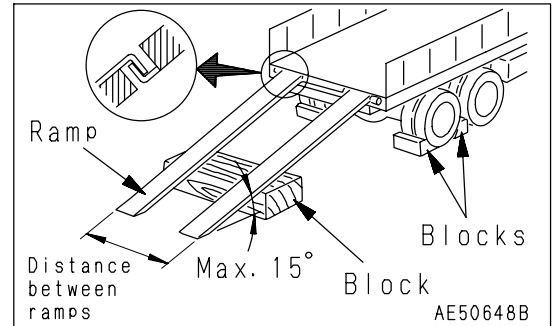

- Be sure the ramp surface is clean and free of grease, oil, ice and loose materials. Remove dirt from machine-tracks. On a rainy day, in particular, be extremely careful since the ramp surface is slippery.
- Run the engine at low idling, set to low speed, and operate the machine slowly when loading or unloading.
- Never correct your steering on the ramps. If necessary, drive off the ramps, correct the direction, then enter the ramps again.
- When the machine is on the ramps, do not operate it other than travel forward or in reverse.
- The center of gravity of the machine will change suddenly at the joint between the ramps and the track or trailer, and there is danger of the machine losing its balance. Travel slowly over this point.
- When loading or unloading to an embankment or platform, make sure that it has suitable width, strength, and grade.
- After the loading, fasten the machine securely with a wire rope and wooden blocks to prevent the machine from moving.

SHIPPING

When shipping the machine on a trailer, do as follows.

- The weight, transportation height, and overall length of the machine differ according to the work equipment, so be sure to confirm the dimensions.
- When passing over bridges or structures on private land, check first that the structure is strong enough to support the weight of the machine. When traveling on public roads, check first with the relevant authorities and follow their instructions.
- For details of the shipping procedure, see "TRANSPORTATION (PAGE 3-95)" in the OPERATION section.

BATTERY

BATTERY HAZARD PREVENTION

Battery electrolyte contains sulphuric acid, and batteries generate flammable hydrogen gas, which may explode. Mistaken handling can lead to serious injury or fire. For this reason, always observe the following precautions.

- When working with batteries, always wear safety glasses and rubber gloves.
- Never smoke or use any flame near the battery.

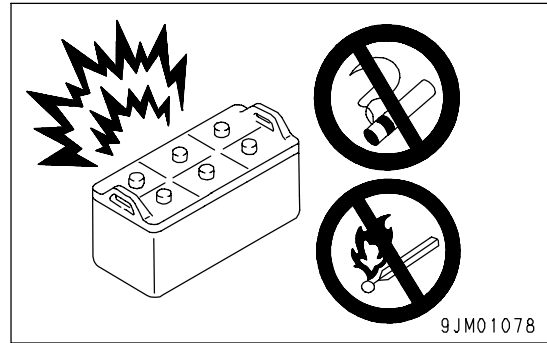

- If you spill acid on your clothes or skin, immediately flush the area with large amount of water.
- If acid gets into your eyes, flush them immediately with large amount of water and seek medical attention.

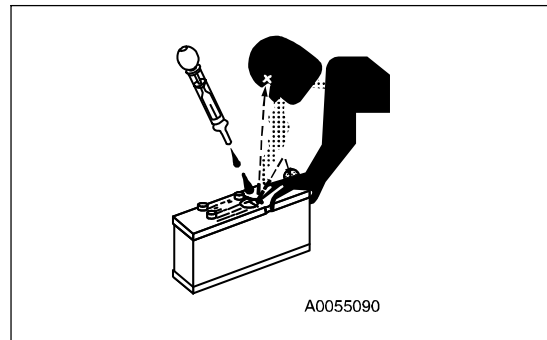

- Before working with batteries, turn the starting switch to the OFF position.

As there is a hazard that sparks will be generated, always do as follows.

- Do not let tools or other metal objects make any contact between the battery terminals. Do not leave tools or other metal objects lying around near the battery.
- Always disconnect the negative (-) terminal (ground side) first when removing the battery; when installing the battery, connect the positive (+) terminal first, and connect the ground last. Tighten the battery terminals securely.
- Flammable hydrogen gas is generated when the battery is charged, so remove the battery from the chassis, take it to a well-ventilated place, and remove the battery caps before charging it.
- Tighten the battery caps securely.
- Install the battery securely to the determined place.

STARTING WITH BOOSTER CABLE

If any mistake is made in the method of connecting the booster cables, it may cause the battery to explode, so always do as follows.

- Starting the engine using a booster cable has to be conducted by a team of two persons with one taking a position at the operator's platform and the other at the battery.
- When starting from another machine, do not allow the two machines to touch.
- When connecting the booster cables, turn the starting switch OFF for both the normal machine and problem machine. There is a hazard that the machine will move when the power is connected.
- Be sure to connect the positive (+) cable first when installing the booster cables. Disconnect the negative (-) cable (ground side) first when removing them.
- When removing the booster cables, be careful not to let the booster cable clips touch each other or to let the clips touch the machine.
- Always wear safety goggles and rubber gloves when starting the engine with booster cables.
- When connecting a normal machine to a problem machine with booster cables, always use a normal machine with the same battery voltage as the problem machine.
- For details of the starting procedure when using booster cables, see "STARTING ENGINE WITH BOOSTER CABLE (PAGE 3-113)" in the OPERATION section.

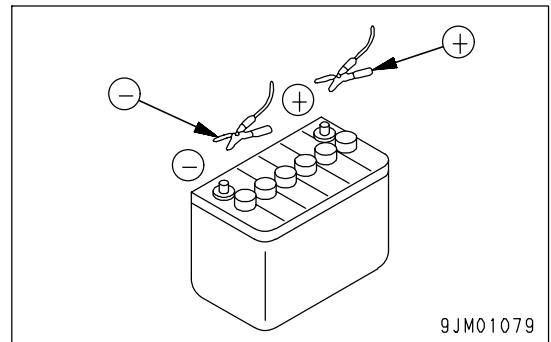
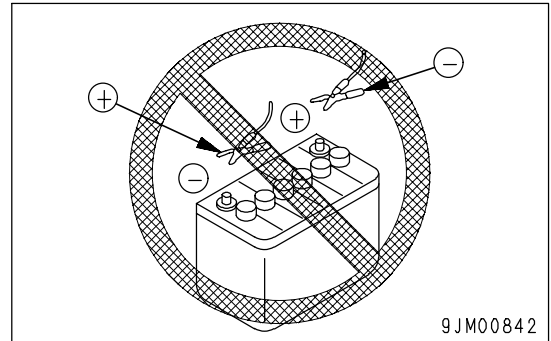

TOWING

WHEN TOWING

Serious injury or death could result if a disabled machine is towed incorrectly or if there is a mistake in the selection or inspection of the wire rope.

- Always wear leather gloves when handling wire rope.
- Fix the wire rope to the track frame.
- During the towing operation, never stand between the towing machine and the machine being towed.
- Never tow a machine on a slope.

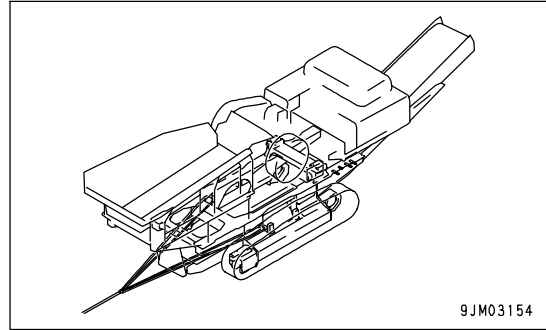

- Never use a wire rope which has cut strands (A), reduced diameter (B), or kinks (C). There is danger that the rope may break during the towing operation.

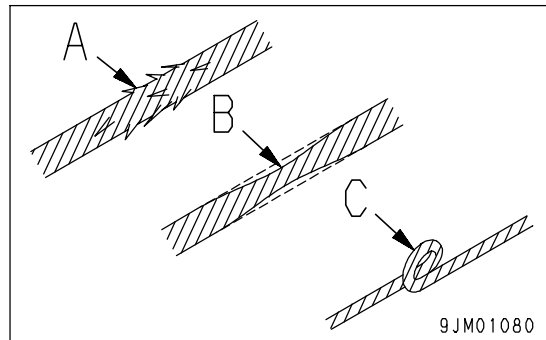

PRECAUTIONS FOR MAINTENANCE

WARNING TAG

- While the engine is being inspected or maintained, attach to the starting switch a warning tag with a message of "DO NOT operate". If judged necessary, put up the same warning signs around the machines, too.

Warning Tag Part No. 09963-03000

Keep this warning tag in the tool box while it is not used. If there is not the tool box, keep the tag in the operation manual pocket.

- Should an irrelevant person start the engine, while the machine is under inspection or maintenance, that would cause a serious accident like bodily injury.

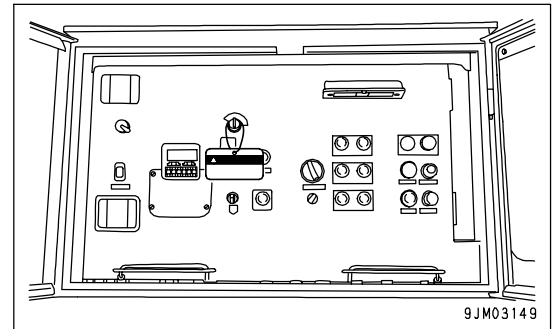

KEEP WORK PLACE CLEAN AND TIDY

- Do not leave hammers or other tools lying around in the work place. Wipe up all grease, oil, or other substances that will cause you to slip. Always keep the work place clean and tidy to enable you to carry out operations safely. If the work place is not kept clean and tidy, there is the danger that you will trip, slip, or fall over and injure yourself.

APPOINT LEADER WHEN WORKING WITH OTHERS

- When repairing the machine or when removing and installing the work equipment, appoint a leader and follow his instructions during the operation.

STOP ENGINE BEFORE CARRYING OUT INSPECTION AND MAINTENANCE

- Stop the machine on firm, level ground.
- Select a place where there is no hazard of falling rocks or landslides, or of flooding if the land is low.
- Stop the engine.

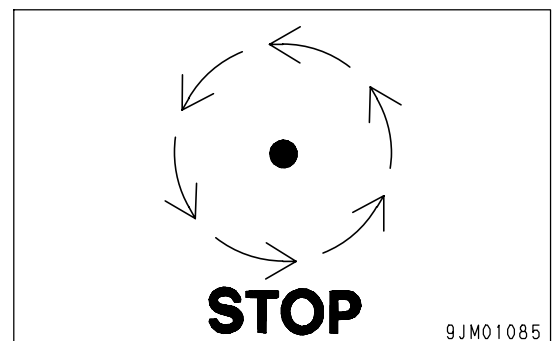

- Put blocks under the track to prevent the machine from moving.

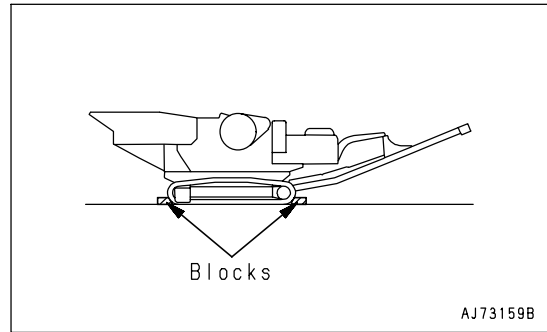

TWO WORKERS FOR MAINTENANCE WHEN ENGINE IS RUNNING

To prevent injury, do not carry out maintenance with the engine running. If maintenance must be carried out with the engine running, carry out the operation with at least two workers and do as follows.

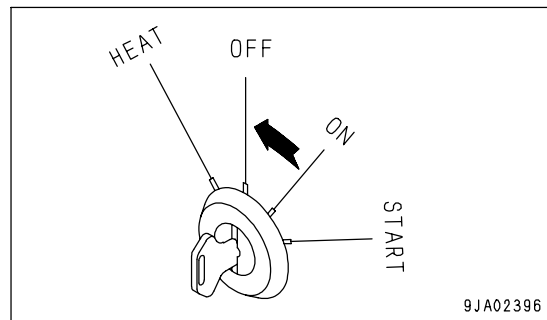

- One of the two should take his/her stand before the control panel, all ready to stop the engine any moment.
- When working near any revolving parts of the machine, exercise the special care, since there is always the danger of getting caught in the revolving parts.
- If it becomes necessary to clean the interior of the radiator with the engine running, turn the mode selector switch (A) to the "Work" position. Moreover make sure that the work will be carried out by two workers in combination.
- Do not touch the control levers. If it becomes unavoidable to do so, signal the partner to evacuate to a safe place.
- If part of your body or tools touch the fan blades or the fan belt, they may be cut off, so never touch any of them.

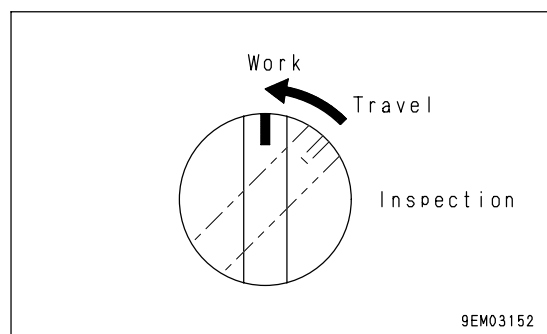
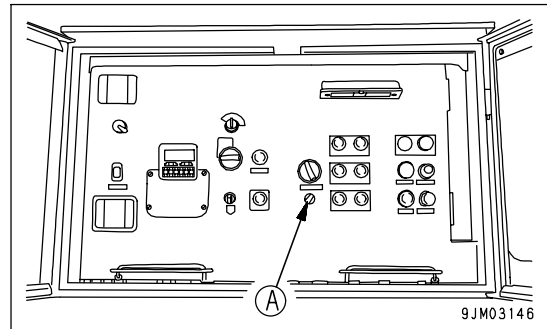

PRECAUTIONS FOR CONVEYOR MAINTENANCE

Since you may get caught in the moving belt conveyor or the rollers, observe the following strictly.

- When maintaining the belt conveyor and the rollers, be sure to stop the belt conveyor and the engine, and then start the work.
- When correcting zigzag movement of the belt conveyor, stop it once, and then start the work.

PROPER TOOLS

Use only tools suited to the task and be sure to use the tools correctly. Using damaged, low quality, faulty, makeshift tools or improper use of the tools could cause serious personal injury.

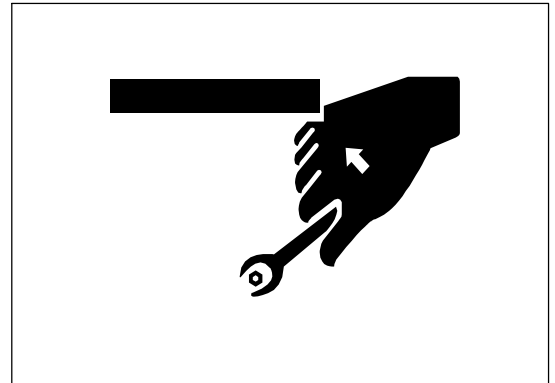
**PERSONNEL**

Only authorized personnel can service and repair the machine. Do not allow unauthorized personnel into the area. If necessary, employ an observer.

PRECAUTIONS WHEN MOUNTING, DISMANTLING AND STORING ATTACHMENTS

- Appoint a leader before starting removal or installation operations for attachments.
- Place attachments that have been removed from the machine in a stable condition so that they do not fall. And take steps to prevent unauthorized persons from entering the storage area.

**PRECAUTIONS FOR WORK UNDER MACHINE**

- If it is necessary to go under the work equipment or the machine to carry out service and maintenance, support the work equipment and machine securely with blocks and stands strong enough to support the weight of the work equipment and machine.

**NOISE**

When carrying out maintenance of the engine and you are exposed to noise for long periods of time, wear ear covers or ear plugs while working.

If the noise from the machine is too loud, it may cause temporary or permanent hearing problems.

PRECAUTIONS WHEN USING HAMMER

When using a hammer, pins may fly out or metal particles may be scattered. This may lead to serious injury. Always do as follows.

- If hard metal parts such as pins or bearings are hit with a hammer, there is a hazard that pieces might be scattered and cause injury. Always wear safety goggles and gloves.
- When hitting pins there is a hazard that broken pieces might be sent flying and injure people in the surrounding area. Always check that there is no one in the surrounding area.
- There is a hazard that the pin hit with strong force may fly out and injure people in the surrounding area.

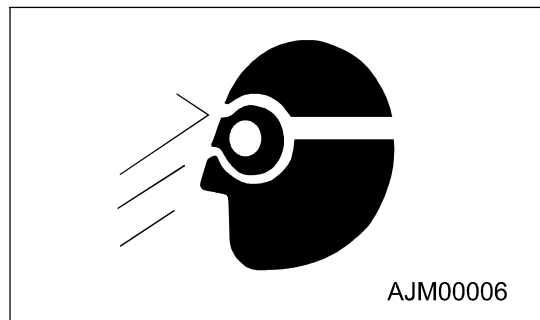

REPAIR WELDING

Welding operations must always be carried out by a qualified welder and in a place equipped with proper equipment. There is a hazard of gas, fire, or electrocution when carrying out welding, so never allow any unqualified personnel to carry out welding.

REMOVING BATTERY TERMINAL

When repairing the electrical system or when carrying out electrical welding, remove the negative (-) terminal of the battery to prevent the flow of current.

PRECAUTIONS WHEN USING HIGH-PRESSURE GREASE TO ADJUST TRACK TENSION

- Grease is pumped into the track tension adjustment system under high pressure. If the specified procedure for maintenance is not followed when making adjustment, grease drain plug (1) may fly out and cause serious injury or property damage.
- When loosening grease drain plug (1) to loosen the track tension, never loosen it more than one turn. Loosen the grease drain plug slowly.
- Never put your face, hands, feet, or any other part of your body close to grease drain plug (1).

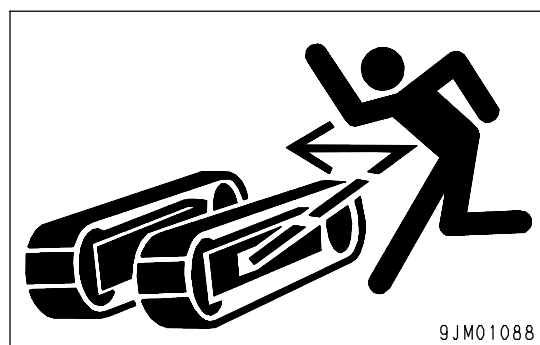
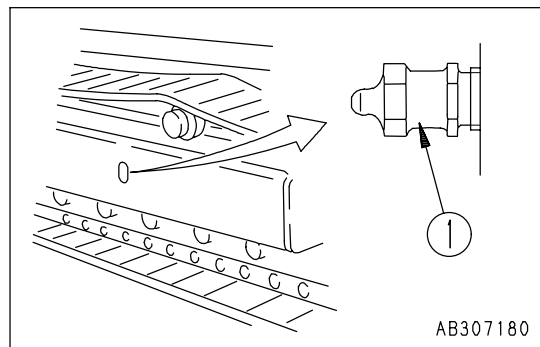

DO NOT DISASSEMBLE RECOIL SPRING

Never attempt to disassemble the recoils spring assembly. It contains a spring under high pressure which serves as a shock absorber for the idler. If it is disassembled by mistake, the spring will fly out and cause serious injury. When it becomes necessary to disassemble it, ask your Komatsu distributor to do the work.

PRECAUTIONS WITH HIGH-PRESSURE OIL

The hydraulic system is always under internal pressure. When inspecting or replacing piping or hoses, always check that the pressure in the hydraulic circuit has been released. If the circuit is still under pressure, it will lead to serious injury, so always do as follows.

- Do not start with the inspection and replacement works, while pressure is still present in the hydraulic circuit.
- If there is any leakage from the piping or hoses, the surrounding area will be wet, so check for cracks in the piping and hoses and for swelling in the hoses.

When carry out inspection, wear safety glasses and leather gloves.

- There is a hazard that high-pressure oil leaking from small holes may penetrate your skin or cause blindness if it contacts your eyes directly. If you are hit by a jet of high-pressure oil and suffer injury to your skin or eyes, wash the place with clean water, and consult a doctor immediately for medical attention.

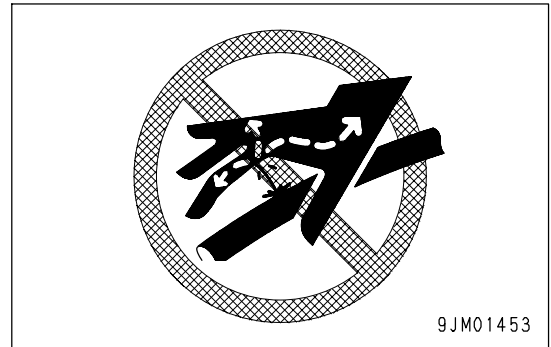

HANDLING HIGH-PRESSURE HOSES

- If oil or fuel leaks from high-pressure hoses, it may cause fire or defective operation, which may lead to serious injury. If any loose bolts are found, stop work and tighten to the specified torque. If any damaged hoses are found, stop operations immediately and contact your Komatsu distributor.

Replace the hose if any of the following problems are found.

- Damaged or leaking hydraulic fitting.
- Frayed or cut covering or exposed reinforcement wire layer.
- Covering swollen in places.
- Twisted or crushed movable portion.
- Foreign material embedded in covering.

WASTE MATERIAL

To prevent pollution, pay careful attention to the method of disposing of waste materials.

- Always put oil drained from your machine in containers. Never drain oil directly onto the ground or dump into the sewage system, rivers, the sea, or lakes.
- Obey appropriate laws and regulations when disposing of harmful objects such as oil, fuel, coolant, solvent, filters, and batteries.

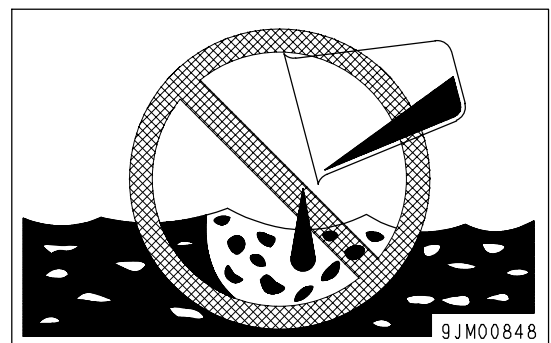

COMPRESSED AIR

- When carrying out cleaning with compressed air, there is a hazard of serious injury caused by flying particles.
- When using compressed air to clean elements or the radiator, always wear safety goggles, dust mask, gloves, and other protective equipment.

PERIODIC REPLACEMENT OF SAFETY CRITICAL PARTS

- It is recommended to carry out machine refueling, inspection and maintenance works without fail and on a periodic basis so that the machine may be used safely for an extended period of time. Be sure to periodically replace the hoses in particular, which are safety critical parts of the machine.

Replacement of safety critical parts: See "PERIODIC REPLACEMENT OF SAFETY CRITICAL PARTS (PAGE 4-21)".

- The material of these components naturally changes over time, and repeated use causes deterioration, wear, and fatigue. As a result, there is a hazard that these components may fail and cause serious injury or death. It is difficult to judge the remaining life of these components from external inspection or the feeling when operating, so always replace them at the specified interval.
- Replace or repair safety-critical parts if any defect is found, even when they have not reached the time specified interval.

OPERATION

WARNING

Please read and make sure that you understand the SAFETY section before reading this section.

GENERAL VIEW

GENERAL VIEW OF MACHINE

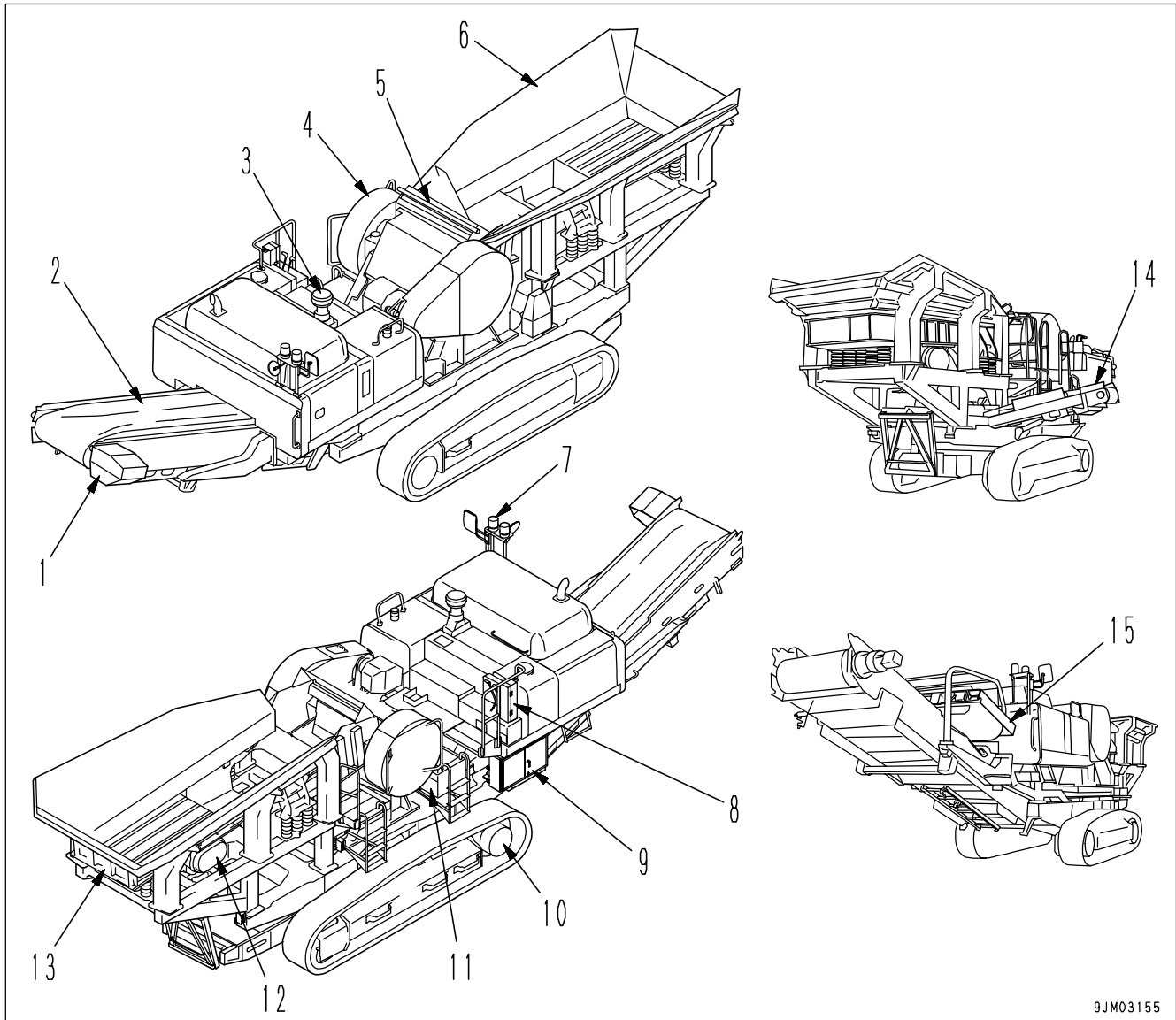

9JM03155

- | | |
|----------------------------|--|
| (1) Belt conveyor motor | (9) Main control box |
| (2) Primary belt conveyor | (10) Sprocket |
| (3) Precleaner | (11) Tool box |
| (4) Jaw crusher | (12) Grizzly feeder vibrator case |
| (5) Sprinkler | (13) Grizzly feeder |
| (6) Hopper | (14) Debris discharging conveyor (if equipped) |
| (7) Revolving warning lamp | (15) Magnetic separator (if equipped) |
| (8) Upper control box | |

GENERAL VIEW OF CONTROLS AND GAUGES

Switches (Main control box and Upper control box)

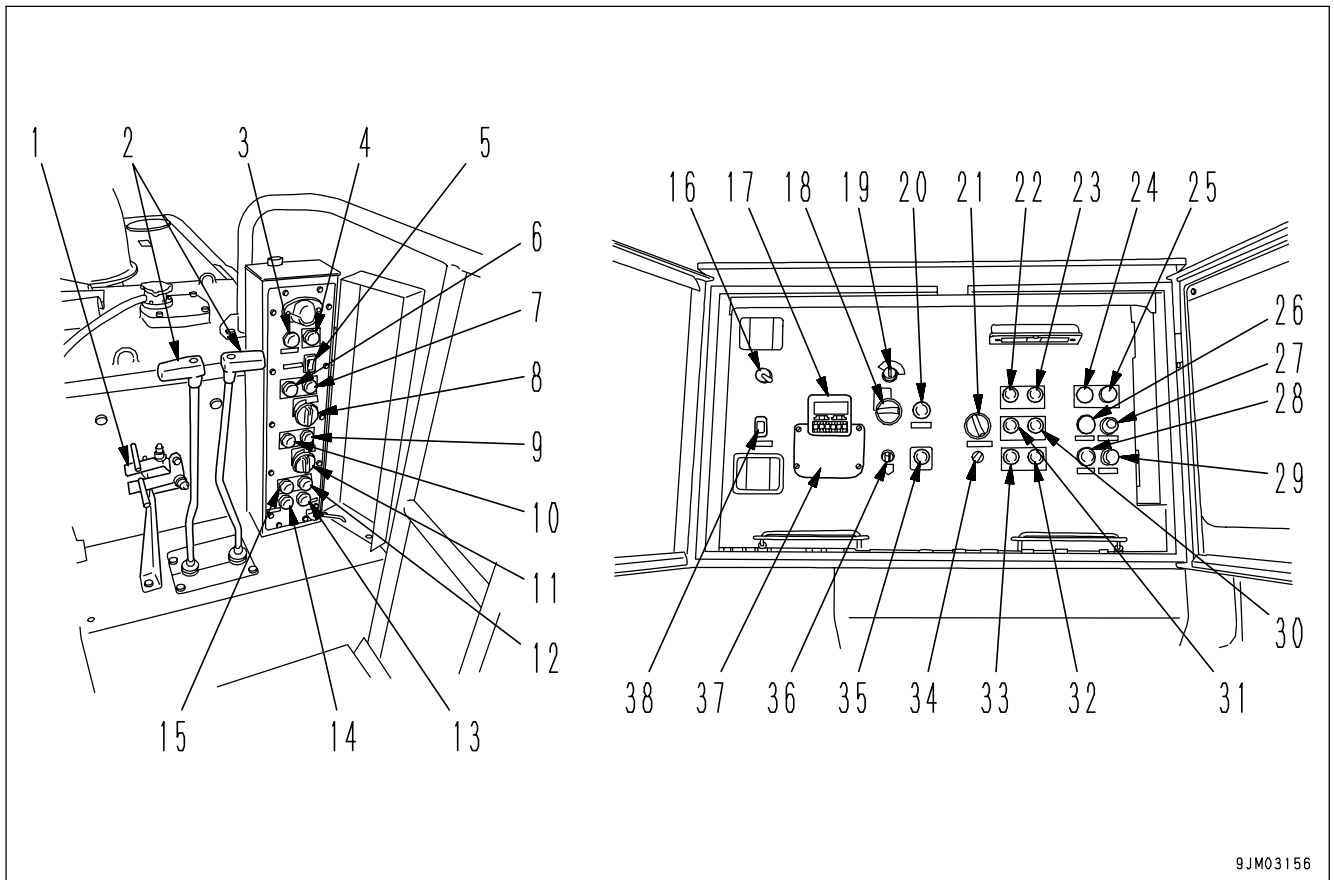

9JM03156

- | | |
|--|--|
| (1) Travel lever safety lock | (20) Horn switch |
| (2) Travel lever | (21) Crusher load setting switch |
| (3) Horn button | (22) Primary belt conveyor starting switch |
| (4) Emergency stop switch | (23) Primary belt conveyor stop switch |
| (5) Travel speed selector switch | (24) Jaw crusher inching switch (normal revolution) |
| (6) Jaw crusher starting switch | (25) Jaw crusher inching switch (reverse revolution) |
| (7) Jaw crusher stop switch | (26) Debris conveyor starting switch (if equipped) |
| (8) Crusher rpm adjustment switch | (27) Debris conveyor stop switch (if equipped) |
| (9) Grizzly feeder stop switch | (28) Magnetic selector starting switch (if equipped) |
| (10) Grizzly feeder starting switch | (29) Magnetic selector stop switch (if equipped) |
| (11) Feeder speed adjustment switch | (30) Jaw crusher stop switch |
| (12) Jaw crusher inching switch (reverse revolution) | (31) Jaw crusher starting switch |
| (13) Crusher clearance expanding switch | (32) Grizzly feeder stop switch |
| (14) Crusher clearance reducing switch | (33) Grizzly feeder starting switch |
| (15) Jaw crusher inching switch (normal revolution) | (34) Operation mode selector switch |
| (16) Radio controller selector switch (if equipped) | (35) Emergency stop switch |
| (17) Monitor | (36) Lamp switch |
| (18) Fuel control dial | (37) Monitor cover |
| (19) Starting switch | (38) Buzzer stop switch |

Machine monitors

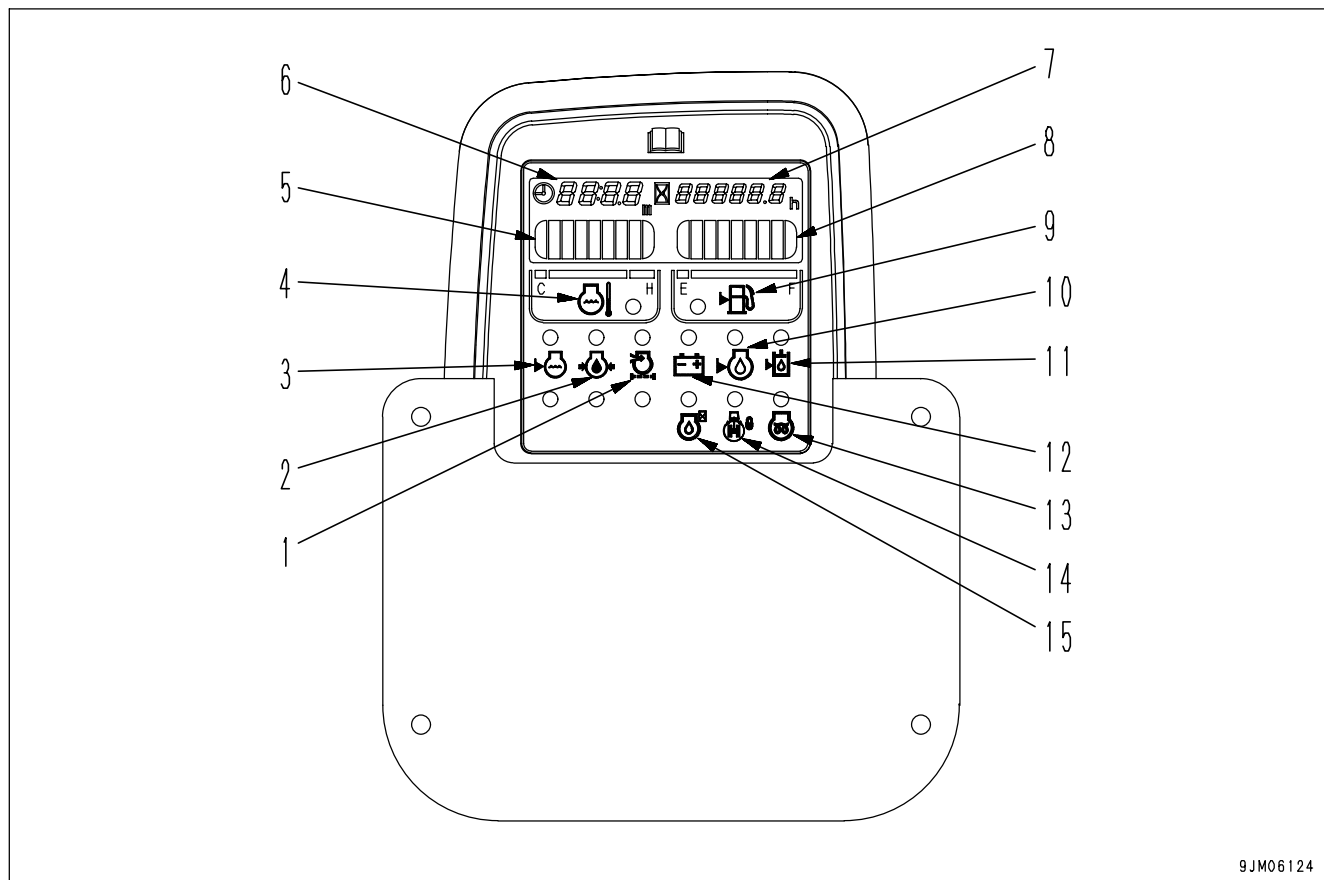

9JM06124

- (1) Air cleaner clogging monitor
- (2) Engine hydraulic pressure monitor
- (3) Radiator water level monitor
- (4) Engine water temperature monitor
- (5) Engine water temperature gauge
- (6) Clock cum defect condition display
- (7) Service meter
- (8) Fuel gauge

- (9) Fuel level monitor
- (10) Engine oil level monitor
- (11) Hydraulic oil level monitor
- (12) Battery charging level monitor
- (13) Engine preheating monitor
- (14) Swing lock monitor
- (15) Engine oil replacement monitor

EXPLANATION OF COMPONENTS

The following is an explanation of devices needed for operating the machine.

To perform suitable operations correctly and safely, it is important to completely understand methods of operating the equipment, and the meanings of the displays.

MACHINE MONITOR

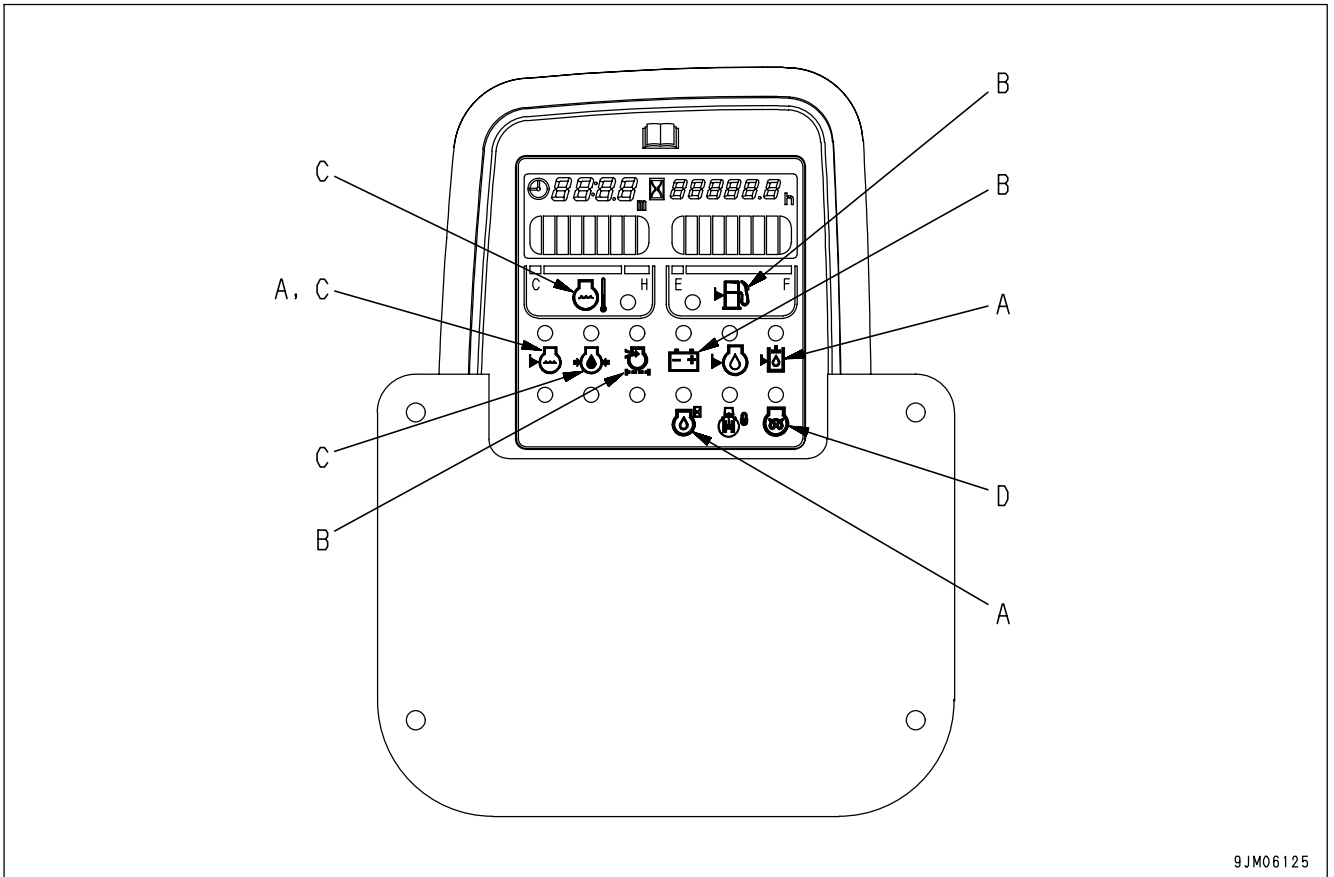

9JM06125

A: BASIC CHECK ITEMS
B: CAUTION ITEMS

C: EMERGENCY STOP ITEMS
D: METER DISPLAY PORTION

BASIC CHECK ITEMS

CAUTION

These monitors are not provided for the purpose of guaranteeing the conditions of the machine. Do not solely rely on the monitors for the daily inspection, but conduct each specified item of the daily inspection without fail.

This displays the basic items that should be checked before starting the engine. If there is any abnormality, the appropriate monitor lamp will flash.

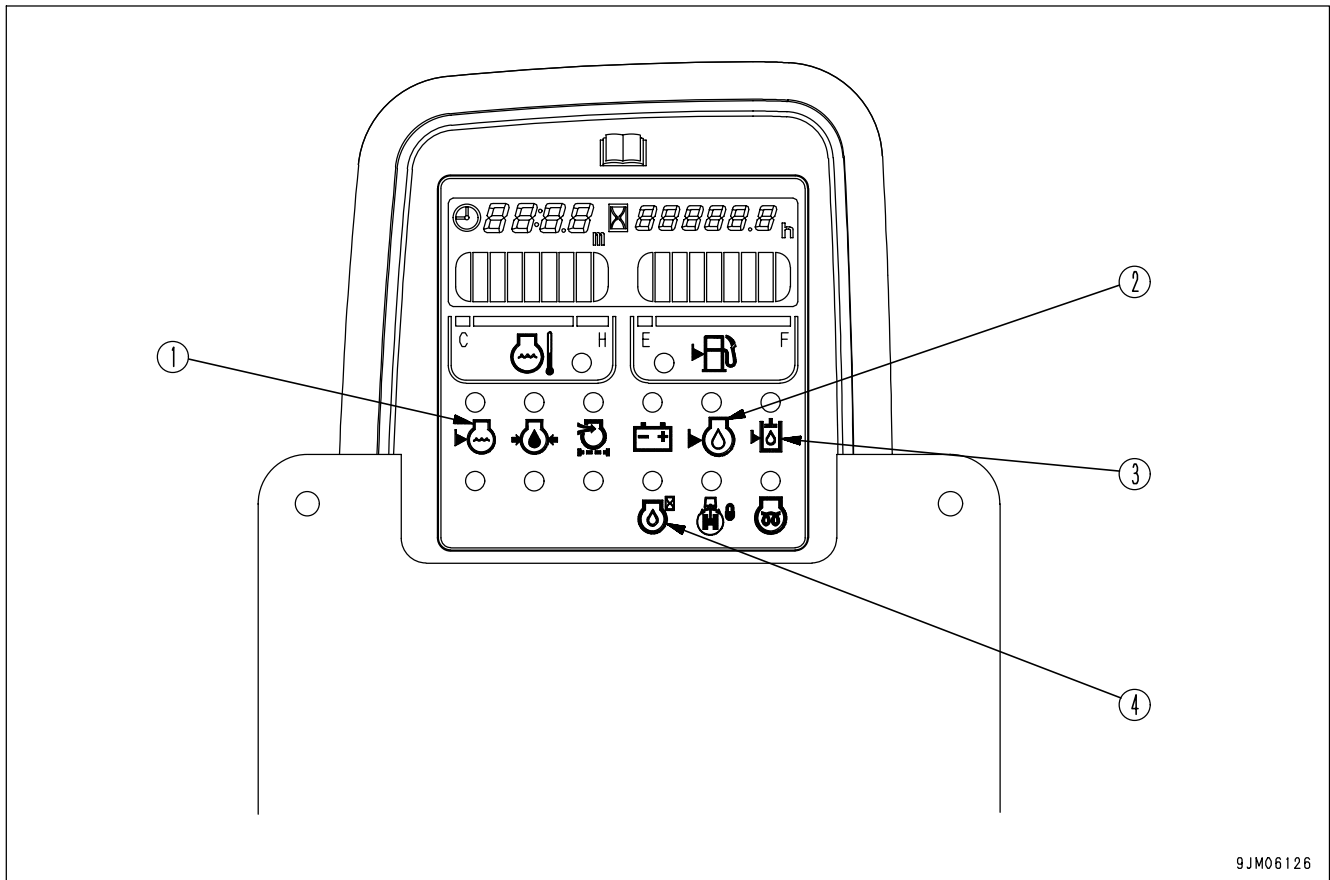

9JM06126

(1) Radiator water level monitor

(2) Engine oil level monitor

(3) Hydraulic oil level monitor

(4) Engine oil replacement monitor (if equipped)

RADIATOR COOLANT LEVEL MONITOR

This monitor (1) warns against the reduced radiator cooling water level.

If the monitor lamp flashes, check the cooling water level in the radiator and sub-tank, and add water.

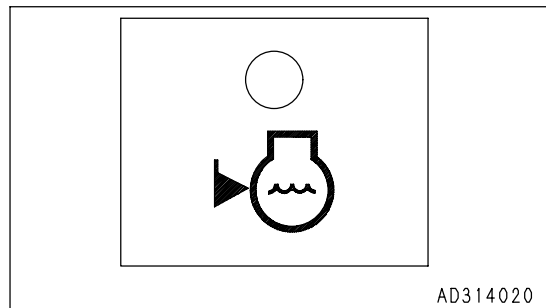

AD314020

ENGINE OIL LEVEL MONITOR

This monitor (2) warns against the reduced engine oil level in the engine oil pan.

If the monitor lamp flashes, check the oil level in the engine oil pan, and add oil.

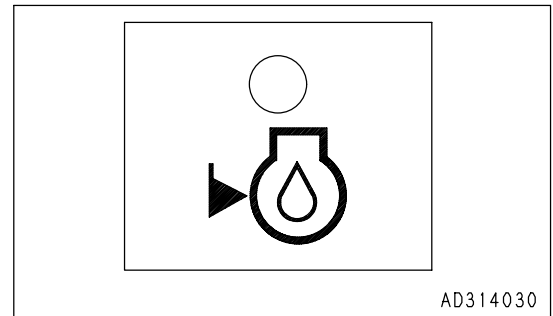
**HYDRAULIC OIL LEVEL MONITOR**

This monitor (3) warns against the reduced hydraulic oil level.

If the monitor lamp flashes, check the hydraulic oil level, and add oil.

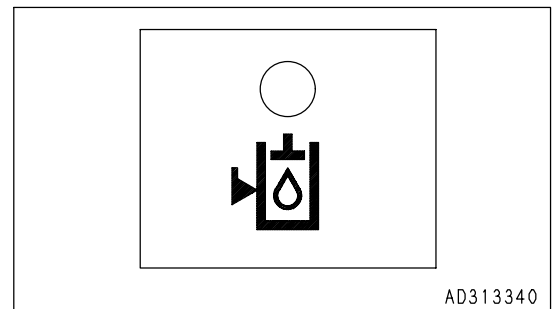
**REPLACEMENT OF ENGINE OIL (For only set machine)**

This monitor (4) gives warning, when the predetermined time for engine oil replacement is overdue.

If the set time (125, 250, 500 H) passes after the engine oil is replaced, this lamp lights up. If the lamp lights up, change the engine oil.

When you want to change the oil replacement interval, consult Komatsu Ltd. or its distributor.

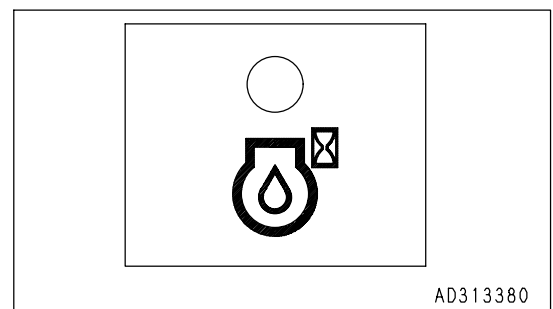

CAUTION ITEMS

CAUTION

When the warning monitor lamp begins to flash or the revolving warning lamp lights up, check and identify the cause in no time. If left unattended for some time, it will lead to a failure.

These are items which need to be observed while the engine is running. If any abnormality occurs, items which need to be repaired as soon as possible are displayed. If there is any abnormality, the appropriate monitor lamp will flash to indicate the location of the abnormality.

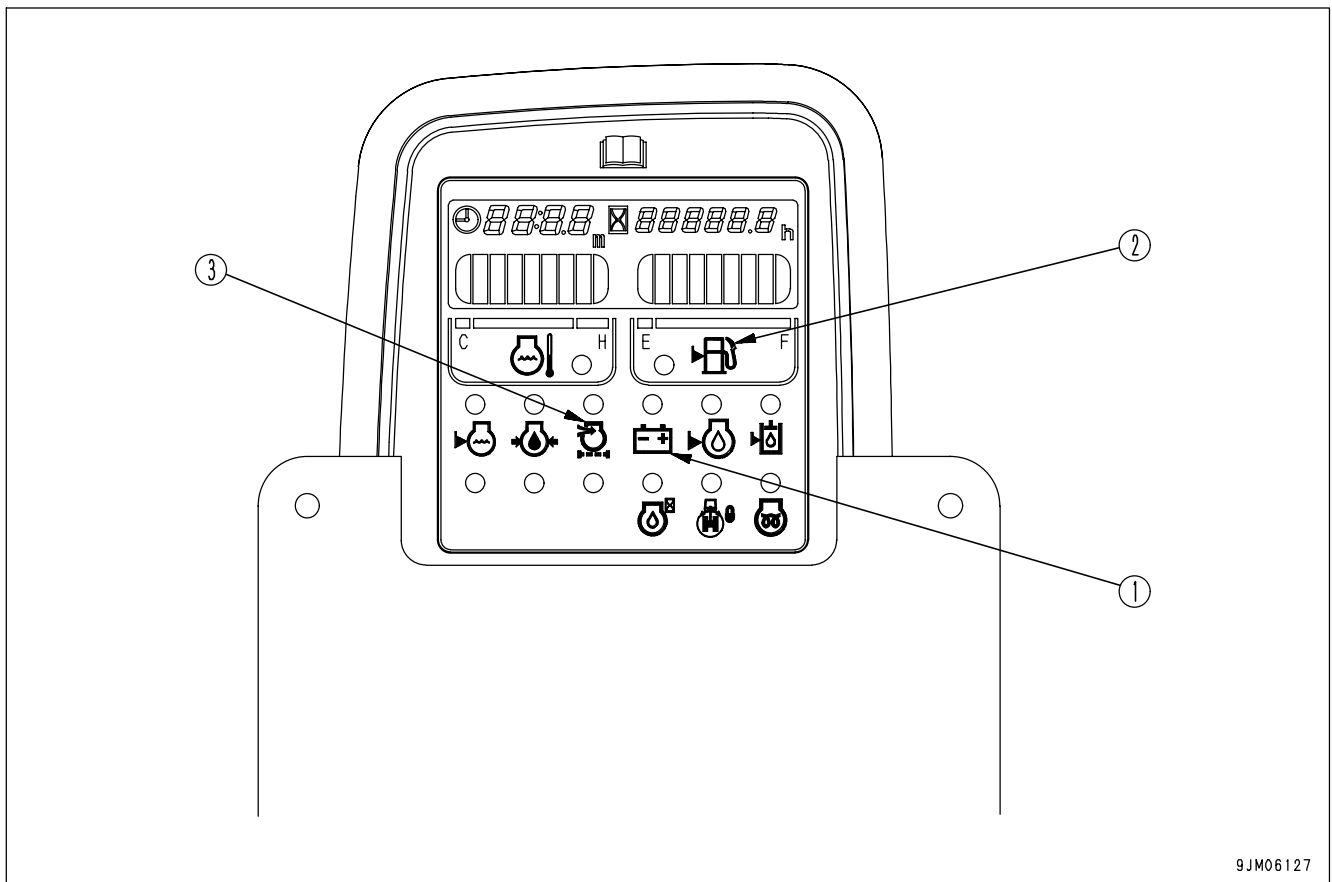

9JM06127

(1) Battery charging level monitor
(2) Fuel level monitor

(3) Air cleaner clogging monitor

CHARGE LEVEL MONITOR

This monitor (1) indicates an abnormality in the charging system while the engine is running.

This monitor indicates an abnormality in the charging system while the engine is running.

While the starting switch is ON, the lamp will remain lit and will go off once the engine is started.

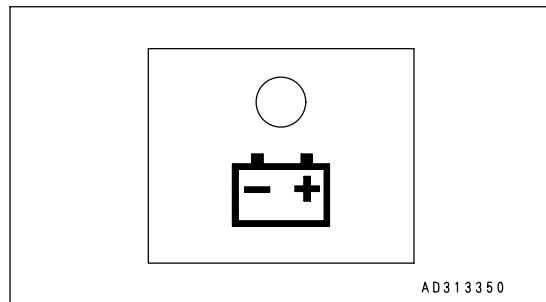

AD313350

FUEL LEVEL MONITOR

This monitor (2) warns against the reduced fuel level in the fuel tank.

When the amount of the remaining fuel in the fuel tank reaches approx. 70 liter (18.49 US gal), this monitor lamp begins to flash. Lose no time in refueling.

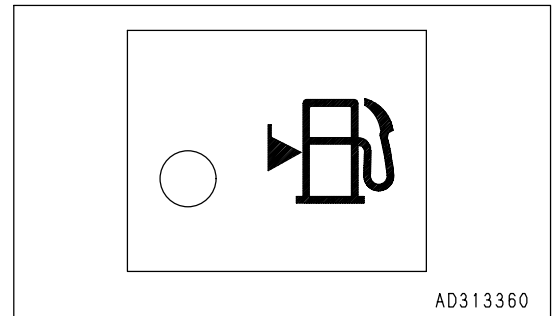
**AIR CLEANER CLOGGING MONITOR**

This monitor (3) warns that the air cleaner is clogged.

If the monitor lamp flashes, stop the engine, then inspect and clean the air cleaner.

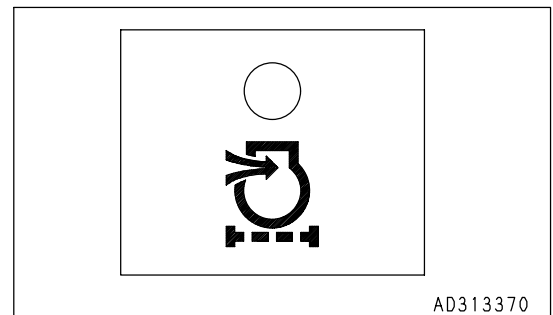

EMERGENCY STOP ITEMS

CAUTION

When this monitor begins to flash or the revolving warning lamp lights up, either stop the engine or reduce the engine speed to low idling immediately, and then check for the trouble spot and take appropriate actions, if necessary.

Take heed of this check item, while the engine is running. If anything unusual takes place on the engine, a relevant monitor lights up and the horn begins to sound. If that happens, take necessary actions at once.

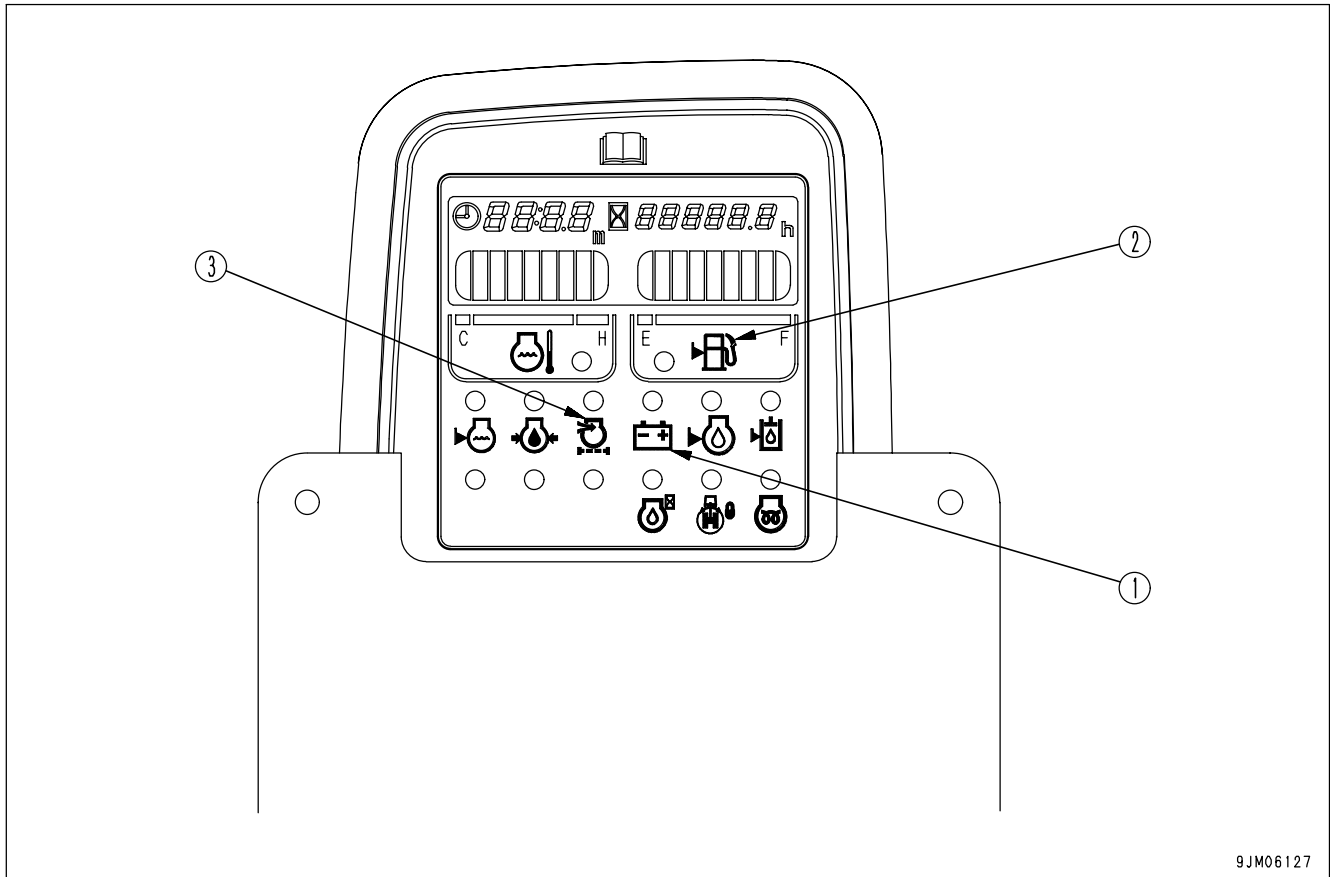

9JM06127

- (1) Engine water temperature monitor
- (2) Radiator cooling water level monitor

- (3) Engine hydraulic pressure monitor

ENGINE COOLANT TEMPERATURE MONITOR

This monitor (1) serves to warn against abnormal rise of the engine coolant temperature.

If the temperature of the engine coolant becomes abnormally high, the monitor lamp flashes, and the overheat prevention system is automatically actuated to reduce the engine speed.

Stop operations and run the engine at low idling until the engine coolant temperature gauge enters the green range.

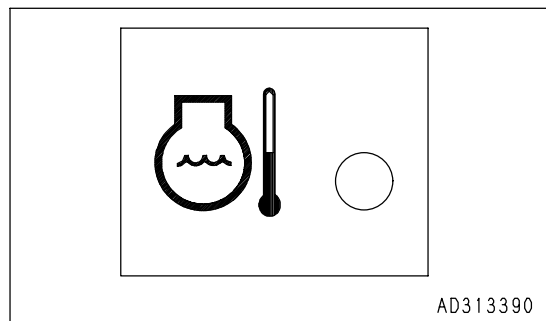

AD313390

RADIATOR COOLANT LEVEL MONITOR

This monitor (2) warns against the fall in the radiator cooling water level.

If the monitor lamp flashes, check the cooling water level in the radiator and sub-tank, and add water.

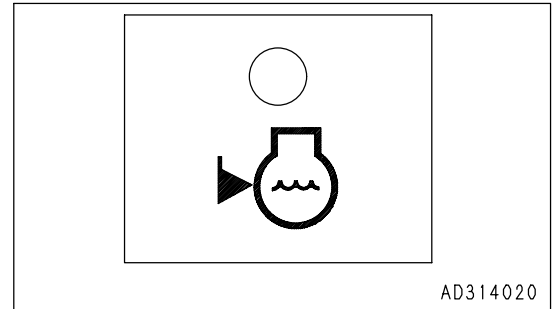
**ENGINE OIL PRESSURE MONITOR**

This monitor (3) flashes if the engine lubricating oil pressure goes below the normal value. If it flashes, stop the engine and check the lubricating system and the level of the oil in the oil pan.

REMARK

The monitor lamp is on all the time as far as the engine starting switch is kept at the "ON" position. Once the engine is started, it goes off. The horn may sound momentarily, when the engine is started. This should not give any concern, as it is nothing abnormal.

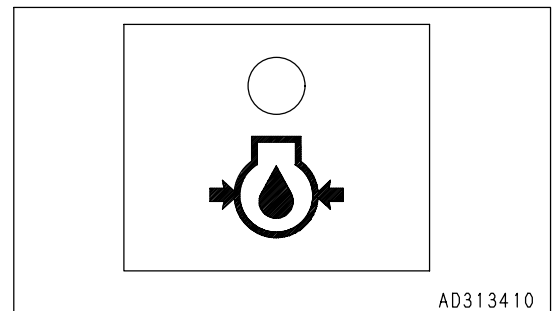

METER DISPLAY PORTION

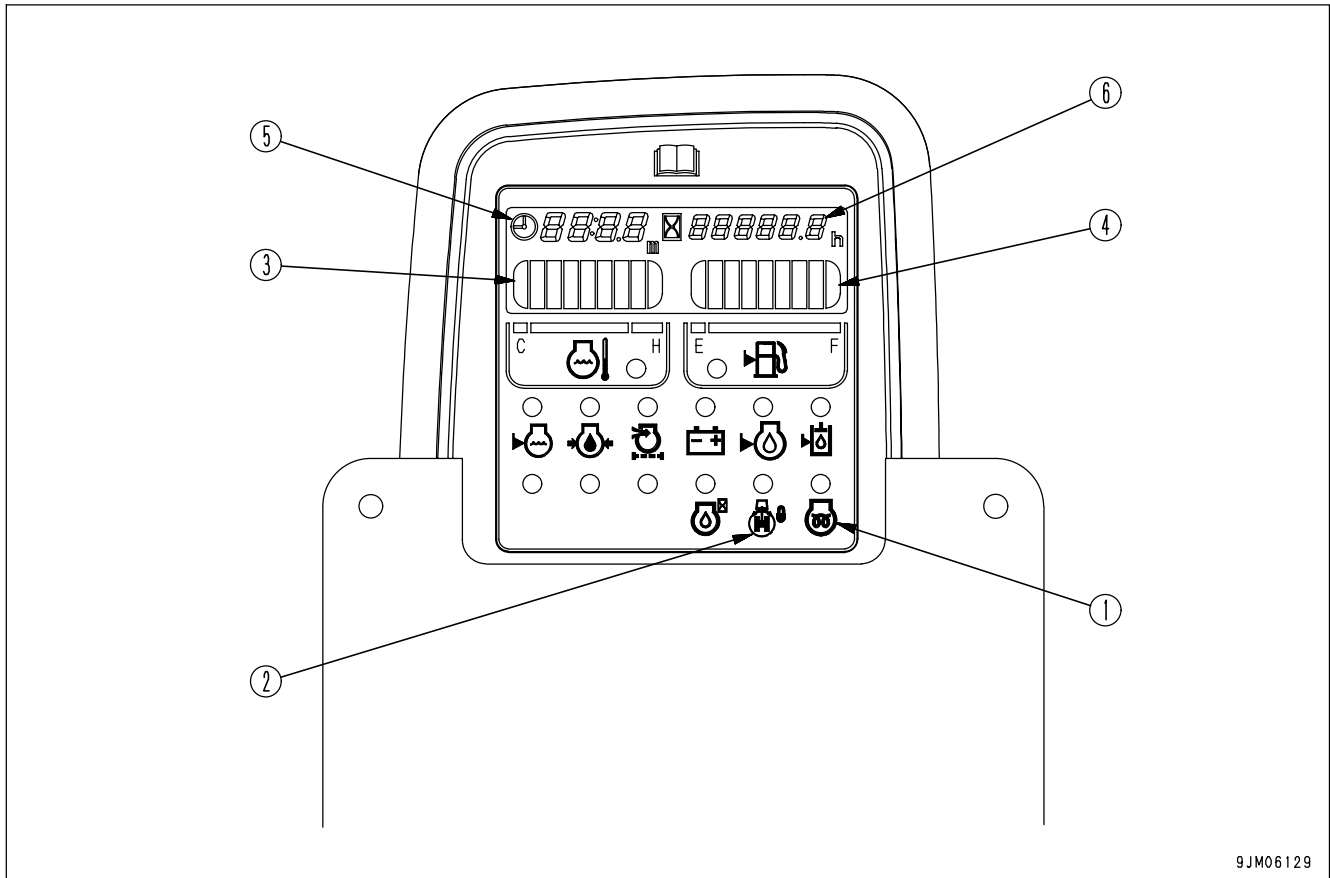

9JM06129

- (1) Engine pre-heating monitor (pilot display)
- (2) Travel lock monitor (pilot display)
- (3) Engine water temperature gauge (meters)
- (4) Fuel gauge (meters)
- (5) Display (meters)
- (6) Service meter (meters)

PILOT DISPLAY PORTION

When starting switch is ON, the pilot display lights up when display items are functioning.

ENGINE PRE-HEATING MONITOR

This monitor (1) indicates the pre-heating time required when starting the engine at an ambient temperature below 0°C (32°F). The monitor lamp lights up when the engine starting switch is turned to the HEAT position and begins to flash after about 30 seconds to show that the pre-heating is completed. (The monitor lamp will go off after about 10 seconds)

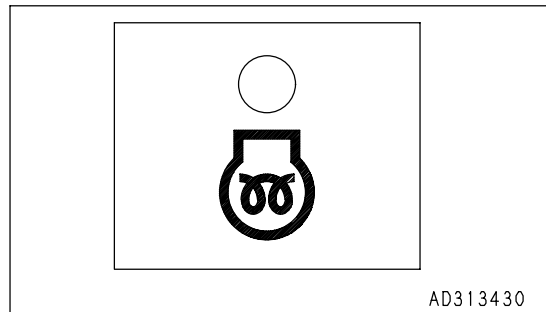

AD313430

TRAVEL LOCK MONITOR

The travel lock monitor lamp lights up when the operation mode selector switch is turned to either "Work" or "Inspection".

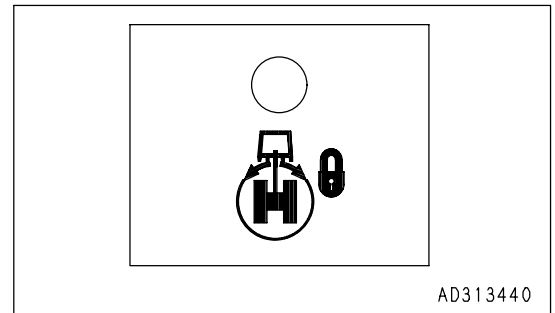

METER PORTION

ENGINE COOLANT TEMPERATURE GAUGE

This gauge (3) indicates the engine cooling water temperature. If the temperature is normal during operation, the green range will light up. If the red range lights up during operation, the overheat prevention system will be actuated.

The engine overheat prevention system works in the following manner.

Lighting-up of red range (A): The engine cooling water temperature monitor lamp (C) flashes.

Lighting-up of red range (B): The engine rpm is reduced to low idling, the engine cooling water monitor lamp (C) flashes and the horn sounds at the same time.

The overheat prevention system works until the temperature enters the green range.

When red range (A) lights, if the engine water temperature is reduced and the fuel control dial is turned to the low idling position, the display will be canceled.

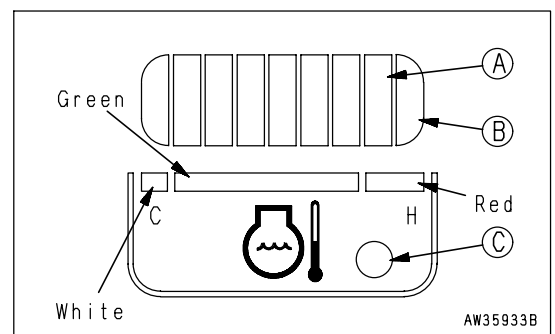

FUEL GAUGE

This meter (4) indicates the amount of the remaining fuel in the fuel tank.

If the green range lights up during the operation, that means the meter functions properly.

If only the red range lights up during the operation, that indicates the residual amount of the fuel in the tank is less than 70 liters (18.49 US gal). Then check the tank and refuel.

Lighting-up of the red range (A): The fuel gauge monitor lamp (B) flashes.

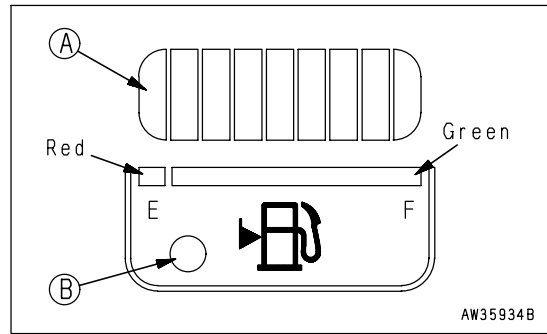

The meter may not show the right fuel level for some time after the engine starting switch has been turned to the "ON" position. This is not an abnormal phenomenon.

When the engine is stopped, turn the starting switch ON and check that each item and the meters light up.

DISPLAY

When the engine starting switch is at the "ON" position, the current time and service meter reading are displayed, if the machine is in a normal condition. If it is in a abnormal condition, the contents of the failure are displayed instead.

When setting the time, symbol (A) flashes.

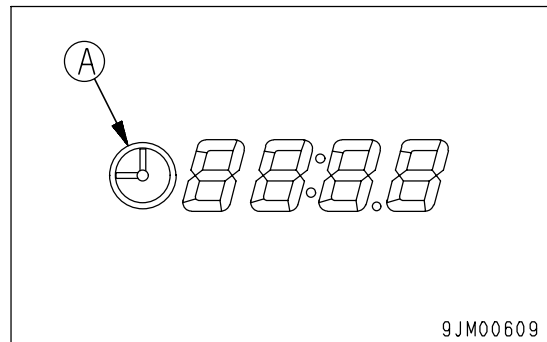

MANUAL SETTING

1. At the time display, keep time switch (B) pressed for at least 2.5 seconds.
2. Symbol (A) flashes.

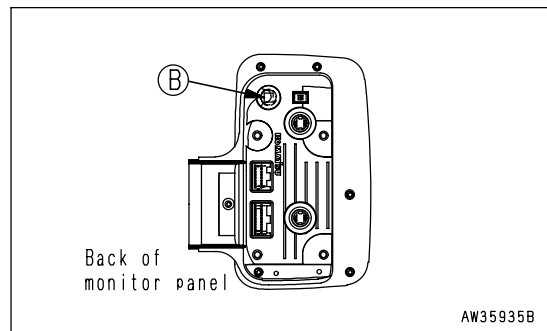

3. A monitor cover (C) is removed.

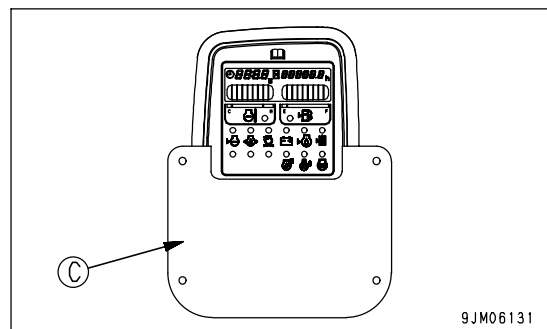

4. When H switch (D) is pressed, the hour advances, and when M switch (E) is pressed, the minutes advance. If the H or M switches are kept pressed for more than 2.5 seconds, the time will advance continuously.
5. When the correct time is reached, press clock switch (B). This completes the clock setting.

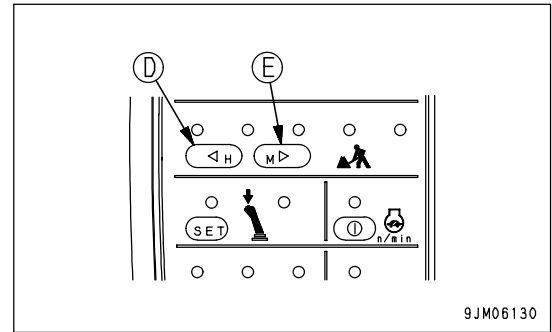

CORRECT TIME SETTING

1. When the time is displayed, depress clock switch (B) for 2.5 sec or more.
2. Symbol (A) flashes.

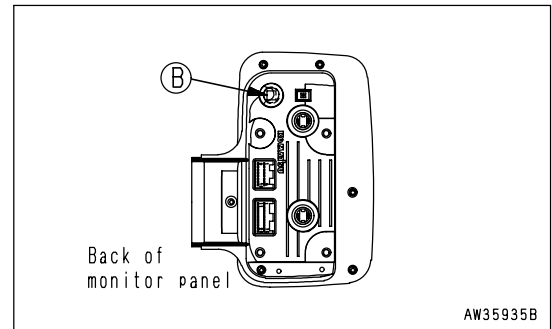

3. When SET switch (C) is pressed, the hour is rounded off for 0 to 14 minutes and rounded up for 45 to 59 minutes.
 [Examples]
 10:14 becomes 10:00 (rounded off)
 10:45 becomes 11:00 (rounded up)
 If the set switch is pressed in time with a time signal or a standard clock, the hour will be set (X hours 00 minutes immediately).

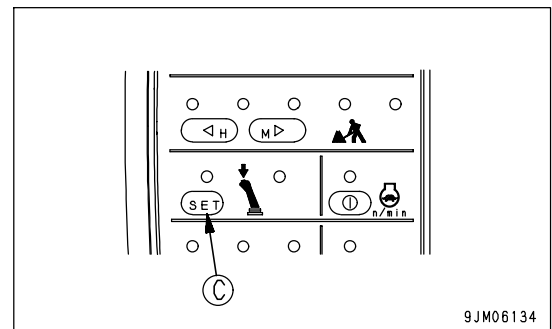

4. After setting the correct time, press the time switch (B) to complete the setting.

REMARK

If the machine has a fault, error information appears while the starting switch is ON. The monitor flashes and displays all error information sequentially.

SERVICE METER

This monitor (6) indicates the total number of hours that the machine has been operated.
 Set the intervals for periodic maintenance according to the time display. The service meter advances while the starting switch is on even if the machine is not moving. The meter will advance by 1 for each hour of operation regardless of the engine speed.

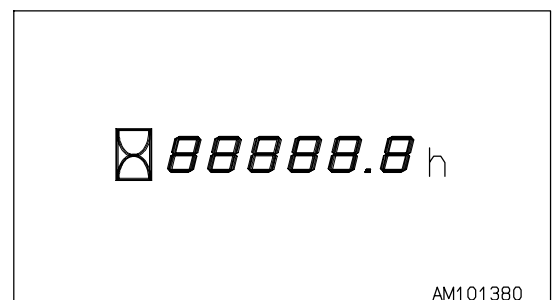

SWITCHES

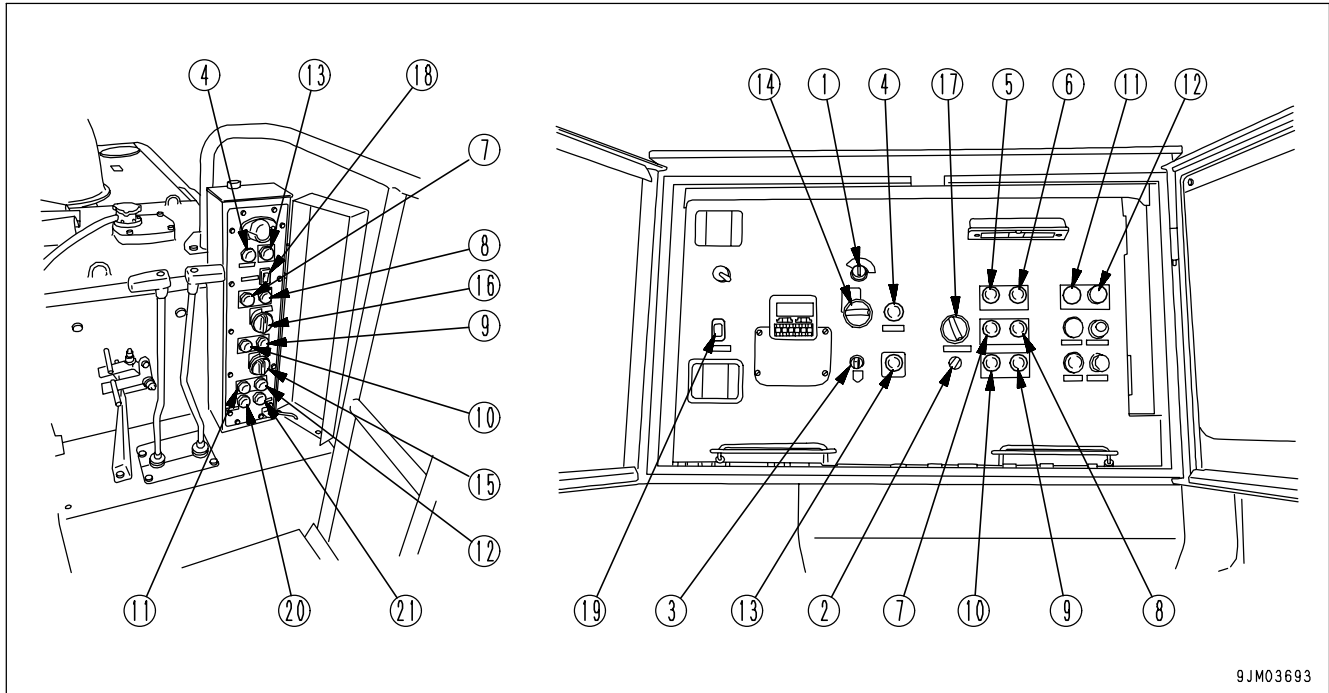

9JM03693

- | | |
|---|--|
| (1) Starting switch | (12) Jaw crusher inching switch (reverse revolution) |
| (2) Operation mode selector switch | (13) Emergency stop switch |
| (3) Lamp switch | (14) Fuel control dial |
| (4) Horn button | (15) Grizzly feeder speed dial |
| (5) Primary belt conveyor starting switch | (16) Crusher rpm adjustment switch |
| (6) Primary belt conveyor stop switch | (17) Crusher load setting dial |
| (7) Jaw crusher starting switch | (18) Travel speed selector switch |
| (8) Jaw crusher stop switch | (19) Buzzer stop switch |
| (9) Grizzly feeder stop switch | (20) Crusher clearance reduction switch |
| (10) Grizzly feeder starting switch | (21) Crusher clearance expansion switch |
| (11) Jaw crusher inching switch (normal revolution) | |

STARTING SWITCH

The engine is started with this switch (1).

OFF Position

At this position, the starting switch key may be freely inserted and pulled out, and all the electric circuits are disconnected.

ON Position

At this position, electricity flows to the battery charging circuit and the lamp circuit.

START Position

At this position, the engine may be started. Once the engine is started, keep the hand off the starting switch key.

HEAT Position

At this position, engine suction air is warmed, facilitating the engine start in a cold ambient temperature.

Keeping the hand off the key, it will automatically return to the OFF position, so set it to the START position immediately.

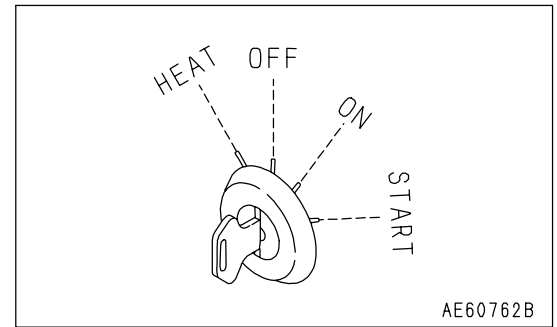

MODE SELECTOR SWITCH

This switch (2) allows an operator to select any of the "Travel", "Work" and "Inspection" modes.

The relationship between each mode and the possible motions of the work equipment is shown in the table below.

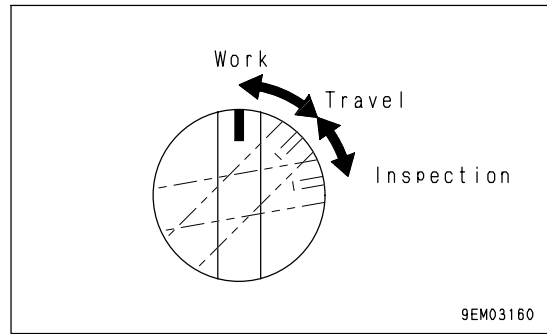

No.	Device (Motion)	Mode			Remark
		Work	Travel	Inspection	
(1)	Crusher continuous operation	○	×	×	
(2)	Crusher inching operation	○	×	○	
(3)	Grizzly feeder operation	○	×	×	
(4)	Primary conveyor operation	○	×	×	
(5)	Magnetic separator operation (if equipped)	○	×	×	
(6)	Debris discharging conveyor (if equipped)	○	×	×	
(7)	Crusher outlet clearance adjustment	×	×	○	
(8)	Primary conveyor raising/lowering	○	○	○	
(9)	Debris discharging conveyor raising/lowering (if equipped)	○	○	○	
(10)	Foldable type hopper cylinder (if equipped)	○	○	○	
(11)	Travel	×	○	×	Machine does not travel when primary conveyor is lowered (working posture).

REMARK

When the mode selector switch is at the "Travel" position, the work equipment (jaw crusher, belt conveyor, grizzly feeder and any other options) may not be set in motion, even if their respective starting switches are depressed.

LAMP SWITCH

This switch (3) turns on the head lamps and the panel lamps.

OFF Position: The lamps are switched off at this position.

Position 1: The panel lamps are switched on.

Position 2: The head lamps and the working lamps are switched on.

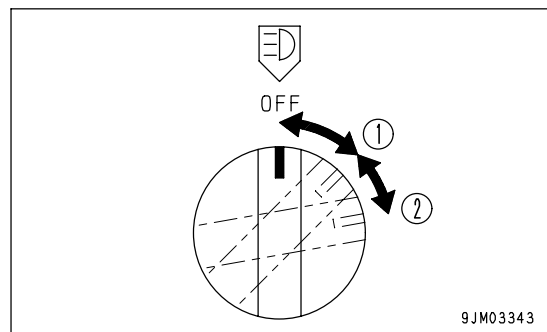

HORN BUTTON

This switch (4) sounds the horn, when depressed.

Be sure to honk it before starting the engine for the purpose of giving warning to those in the surrounding.

Furthermore the horn begins to sound when any of the following situations develops.

If two or more abnormalities take place at a time, the horn continues to sound in the order of (1), (2) and (3) shown in the table.

No.	Items of Abnormality	Horn Sounding Mode
(1)	• Engine water temperature abnormal	Horn keeps sounding until fuel control dial is set to low idling position.
	• Engine oil pressure abnormal	
	• Battery charging level abnormal	
(2)	• Controller detected failure. (Error code is displayed)	ON and OFF for a second each are alternated three times.
(3)	• All work stopped due to abnormal load applied to belt conveyor.	Horn keeps sounding for five seconds.
	• All work stopped due to abnormal load applied to crusher.	
	• All work stopped due to abnormal load applied to side conveyor (if equipped).	
	• All work stopped due to abnormal load applied to magnetic separator.	

PRIMARY CONVEYOR START SWITCH

This switch (5) sets the primary belt conveyor in motion, and the conveyor transports crushed debris and stones out of the machine.

PRIMARY CONVEYOR STOP SWITCH

This switch (6) stops the primary belt conveyor, when depressed.

JAW CRUSHER START SWITCH

This switch (7) sets the jaw crusher in motion, when depressed, causing it to start a crushing work.

JAW CRUSHER STOP SWITCH

This switch (8) stops the jaw crusher, when depressed.

GRIZZLY FEEDER STOP SWITCH

This switch (9) stops the grizzly feeder, when depressed.

GRIZZLY FEEDER START SWITCH

This switch (10) sets the grizzly feeder in motion, when depressed, and the feeder supplies the crusher with debris and stones, while screening earth and sand from among the debris loaded in the hopper.

JAW CRUSHER INCHING SWITCH (NORMAL REVOLUTION)**CAUTION**

While the crusher is in operation (e.g. after the crusher starting switch has been depressed), neither of the crusher revolution manually normalizing switch and the crusher revolution manually reversing switch works. This is because the crusher is programmed to prioritize the work.

This switch (11) is used when maintaining or inspecting the jaw crusher, or used in order to prevent bridging and blocking conditions from developing in the jaw crusher.

It is used when adjusting the clearance at the outlet of the jaw crusher and also when positioning the flywheel (for an inching operation).

Moreover, if used in combination with the jaw crusher inching switch (reverse revolution) (12), it facilitates to remove the foreign materials stuck at the outlet of the jaw crusher.

When using this switch, set the engine speed at low idling.

JAW CRUSHER INCHING SWITCH (REVERSE REVOLUTION)**CAUTION**

While the crusher is in operation (e.g. after the crusher starting switch has been depressed), neither of the crusher revolution manually normalizing switch and the crusher revolution manually reversing switch works. This is because the crusher is programmed to prioritize the work.

This switch (12) is used when maintaining or inspecting the jaw crusher, or used in order to prevent bridging and blocking conditions from developing in the jaw crusher.

It works the same way as the jaw crusher inching switch (normal revolution) (11) does. When some foreign material has clogged the outlet of the jaw crusher, depress this switch after stopping the crusher and you can easily remove that material.

When using this switch, set the engine speed at low idling.

REMARK

The jaw crusher keeps either normal or reverse rotation as long as this switch is pressed down with a finger.

EMERGENCY STOP SWITCH

This switch (13) rings a buzzer, when depressed, and stops all the work equipment.

The engine does not stop at that time.

For starting the work equipment again, stop the engine once, bring the emergency switch back to the "OFF" position and try to restart them.

The emergency switch returns to the "OFF" position, if it is depressed again.

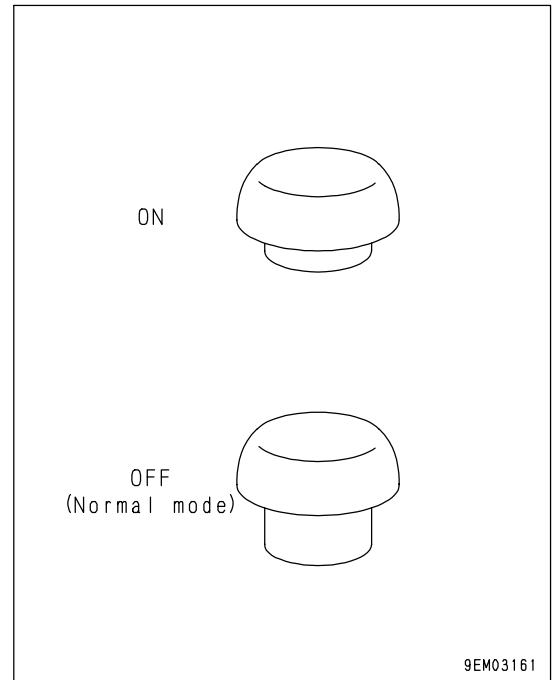

FUEL CONTROL DIAL

NOTICE

- Set the engine starting switch key to ON position after confirming the fuel control dial is at the low idling (MIN) position.
- When starting the work, set the fuel control dial to the MAX position.

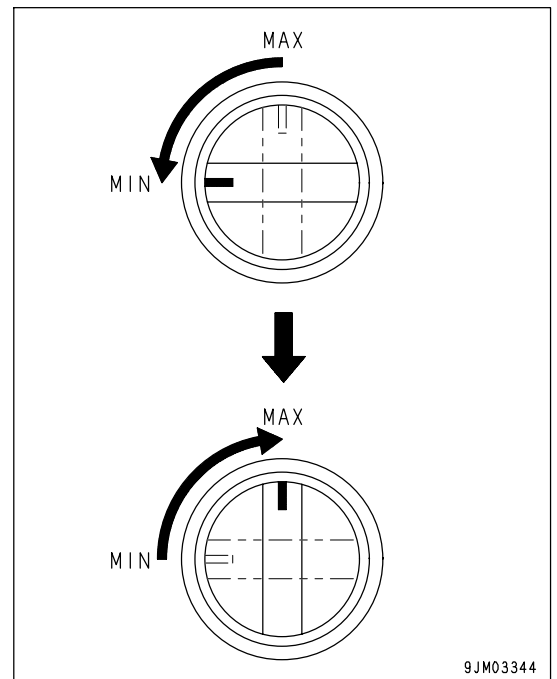

This dial (14) is used to adjust the speed and the output of the engine.

- (a) Low idling (MIN): Turn the dial to the left end.
- (b) Full speed (MAX): Turn the dial to the right end.

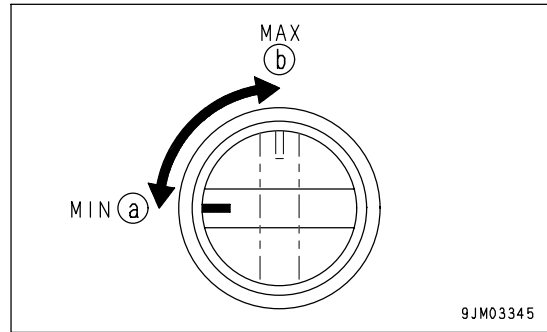

GRIZZLY FEEDER SPEED SETTING DIAL

(Upper Control Box)

This dial (15) is used to change the frequency of the grizzly feeder to adjust the debris and rock feeding speed.

- (a) Stop feeding (MIN): Turn the dial to the left end.
- (b) Maximum feeding speed (MAX): Turn the dial to the right end.

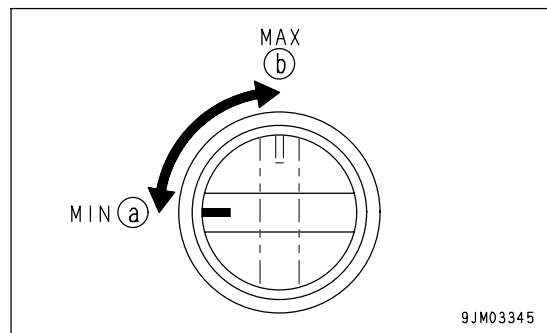

JAW CRUSHER SPEED SETTING DIAL

This dial (16) is used to adjust the rotating speed of the crusher.

- (a) Partial speed (MIN): Turn the dial to the left end (70% of the full speed).
- (b) Full speed (MAX): Turn the dial to the right end.

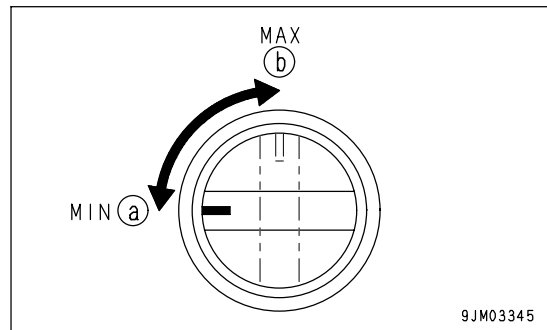

CRUSHER CHARGE SETTING DIAL

This dial (17) serves to constantly maintain the charging rate at the crusher chamber at about 60% of its capacity under any working condition so as to enable the crusher to manifest the maximum capability.

This dial is used to adjust the debris feeding volume from the grizzly feeder to the crusher.

Keep watching the crusher charging rate for about an hour after starting crushing work, and adjust the crusher charge setting dial to the optimum level.

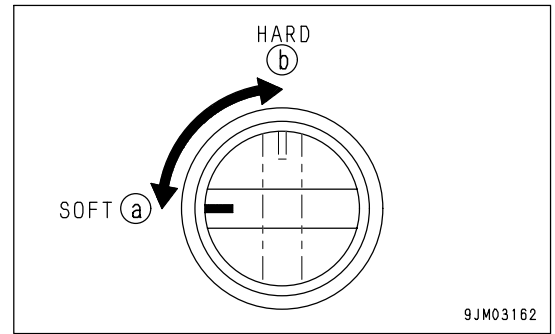

Guideline for dial adjustment

SOFT ← ————— → HARD

- Concrete debris • Andesite • Granite
- Limestone • Sandstone • Basalt
- Graywacke
(Hard sandstone)

TRAVEL SPEED SELECTOR SWITCH

 **WARNING**

If you try to change the travel speed from the Hi to Lo position, while the machine is traveling, the machine may swerve from the straight path.

Change the travel speed after stopping machine once.

This switch (18) is used to change the travel speed in two stages.

Position (a): Travel in high speed

Position (b): Travel in low speed

REMARK

When the machine is run by means of the optional radio controller, it travels at a low speed without any relation to the mode of the travel speed selector switch.

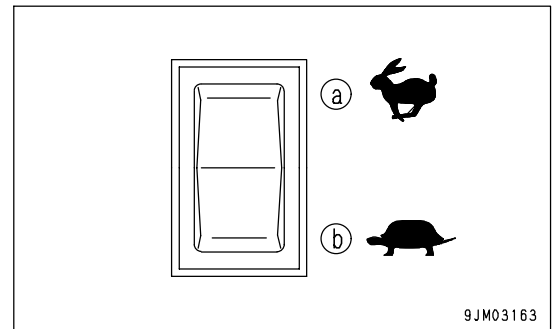

BUZZER STOP SWITCH

NOTICE

If the engine starting switch is turned OFF because some abnormality has been noticed in the machine, and turned ON again, the buzzer sounds, unless that abnormality has not been removed.

This switch (19) stops the buzzer from ringing, when it begins to ring to warn against any of the warning items that has occurred while the engine is running.

CRUSHER CLEARANCE REDUCTION SWITCH

NOTICE

Operate this switch only after confirming that no debris or earth remains inside the crusher chamber.

The clearance at the jaw crusher outlet continues to be reduced, while keeping this switch (20) depressed.

CRUSHER CLEARANCE EXPANSION SWITCH

The clearance at the jaw crusher outlet continues to be widened, while keeping this switch (21) depressed.

CONVEYOR UP/DOWN SWITCH

This switch is used to raise and lower the primary belt conveyor.

Depress (1): The belt conveyor is raised.

Depress (2): The belt conveyor is lowered.

The belt conveyor raising and lowering cylinder works only while the switch is kept depressed.

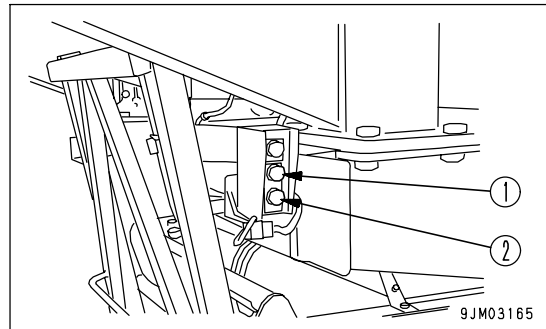

EMERGENCY PUMP DRIVING SWITCH

NOTICE

The pump drive emergency switch is provided to make it possible to perform work for a short time when there is a failure in the pump control system. It is necessary to repair the abnormal location as soon as possible.

This switch is used so that the work may be resumed temporarily, when something unusual takes place on the pump control system, (e.g. the display denotes E02).

Under normal condition: The switch is down.

Under abnormal condition: The switch is up.

When the display denotes E02, raise this switch and the work may be continued.

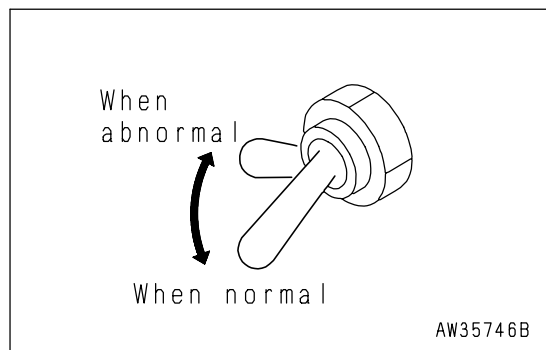
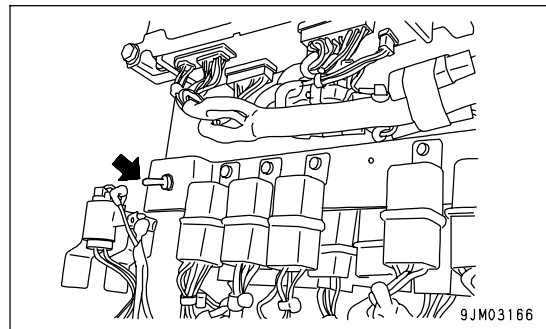

CONTROL LEVERS

TRAVEL LEVERS

This control lever is used to run the machine.

(1) Forward: Push the control lever forward.

(2) Reverse: Pull the lever toward yourself.

N Neutral: The machine comes to a halt.

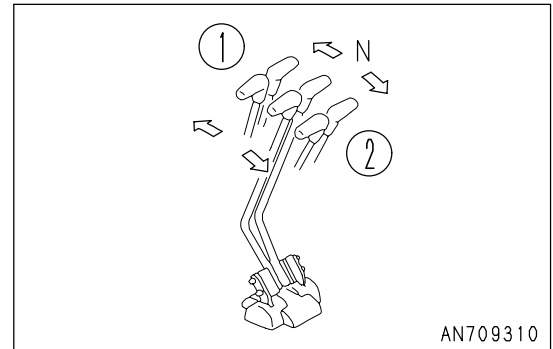

When you shift the travel control lever from Neutral to Forward, or from Neutral to Reverse, an alarm begins to sound to caution the people around the machine that it is about to move.

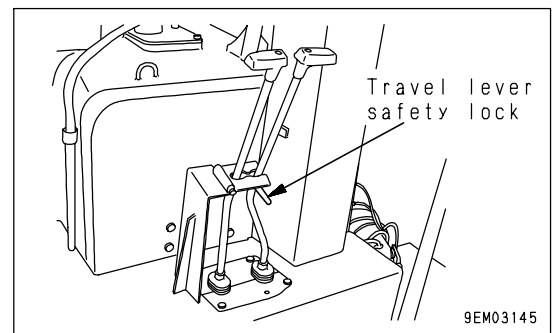

OPTION-RELATED SWITCHES



CAUTION

If any of the switches for the optional work equipment is depressed by mistake, an abnormal load is applied to the machine and as a result the horn begins to sound, so take care not to depress it inadvertently.

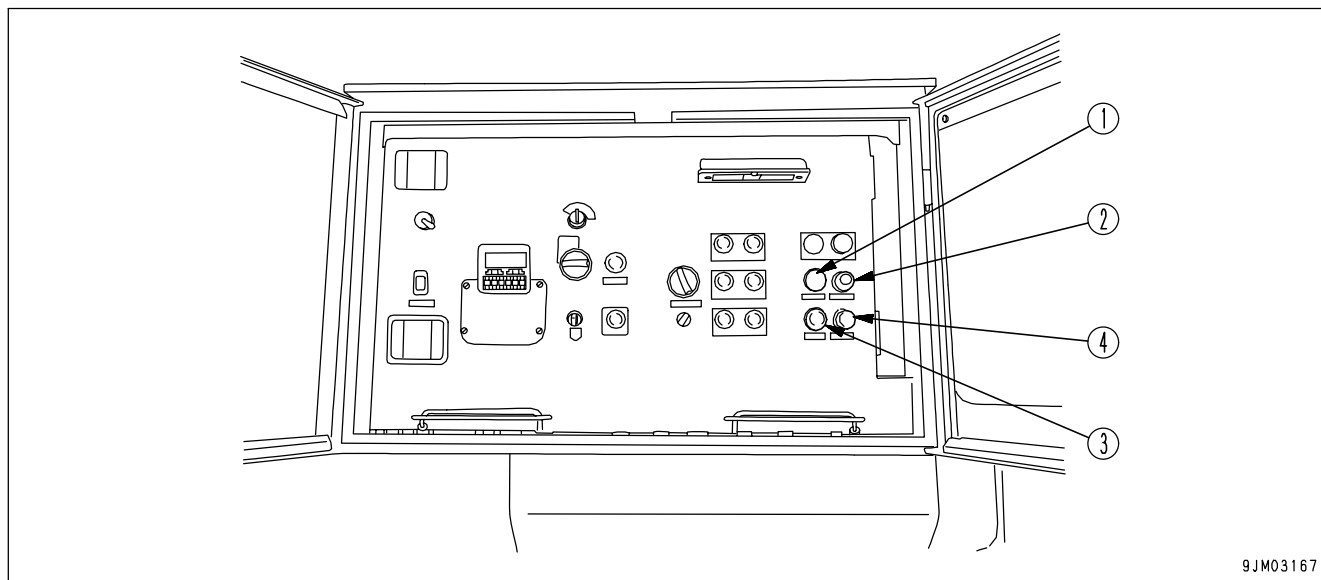

9JM03167

(1) Debris discharging belt conveyor starting switch

(2) Debris discharging belt conveyor stop switch

(3) Magnetic selector starting switch

(4) Magnetic selector stop switch

MUCK DISCHARGE CONVEYOR START SWITCH

This switch (1) activates the debris discharging belt conveyor, when depressed, and sand and earth screened by the grizzly feeder will be taken out of the machine.

MUCK DISCHARGE CONVEYOR STOP SWITCH

This switch (2) stops the debris discharging belt conveyor, when depressed.

MAGNETIC SELECTOR START SWITCH

This switch (3) activates the magnetic selector, when depressed, and metallic objects like iron and steel bars mixed with the crushed debris on the primary belt conveyor will be removed.

MAGNETIC SELECTOR STOP SWITCH

This switch (4) stops the magnetic selector, when depressed.

CAP, COVER WITH LOCK

A lock is provided at the following locations of the machine; the oil filler of the fuel tank, the oil filler of the hydraulic oil tank, the main control box cover, the tool box, the engine hood, the battery box cover and the left and right side doors.

Use the engine starting switch key when opening and closing the caps.

METHOD OF OPENING AND CLOSING CAP WITH LOCK

Insert the key as far as it will go to the shoulder. If the key is turned before it is inserted all the way, it may break.

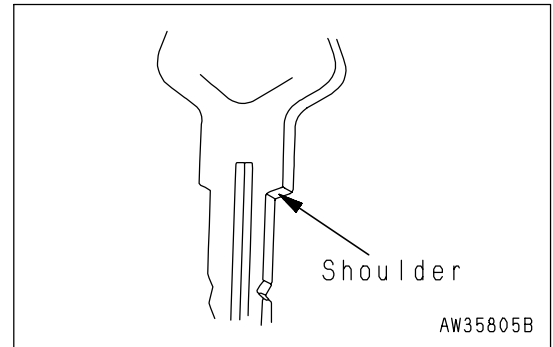

TO OPEN THE CAP

1. Insert the key into the cap slit as far as it will go.
2. Turn the key from the LOCK position to the OPEN position, and the cap can be opened.

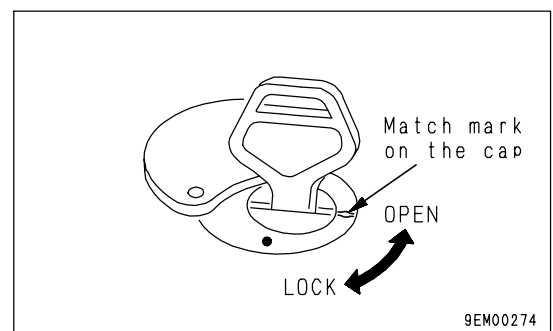
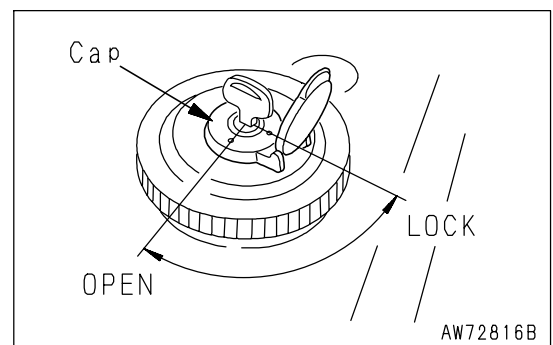

TO LOCK THE CAP

1. Screw the cap in the oil filler of the fuel tank.
2. Turn the key from the OPEN position to the LOCK position, and pull it out.

METHOD OF OPENING AND CLOSING COVER WITH LOCK**TO OPEN THE COVER**

1. Insert the key into the key slot.
2. Turn the key counterclockwise and open the cover by pulling the cover grip.

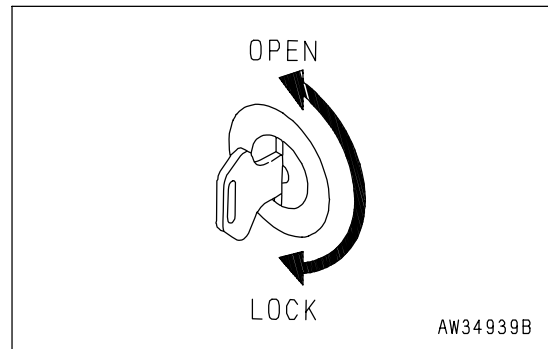
**TO LOCK THE COVER**

1. Close the cover and insert the key into the key slot.
2. Turn the key clockwise and take the key out.

REVOLVING WARNING LAMP

(Yellow)

- The revolving warning lamps light on and off on the following occasions.

Should two or more troubles take place simultaneously, the revolving warning lamps light on and off in the order of (1), (2) and (3) as indicated in the table below. Refer to the right column in the table for the different ways that the revolving warning lamps light on and off according to the causes.

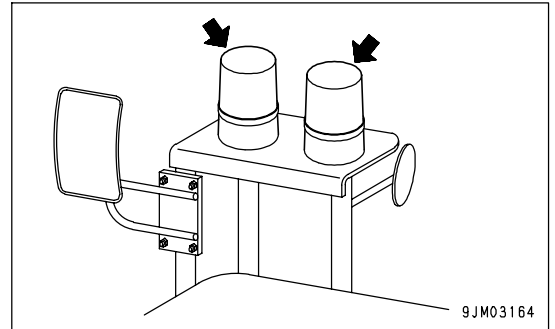

No.	Item of Abnormality	Display of Revolving Working Lamp
(1)	• Engine water temperature abnormal (over 105°C degrees)	Revolving working lamp keeps flashing, if any of abnormalities listed at left takes place. (When the cause is removed, the lamps goes off)
	• Engine oil temperature abnormal	
	• Battery charging level abnormal	
	• Residual fuel amount abnormal (below 70 liter (18.49 US gal))	
	• Radiator cooling water level abnormal	
	• Engine oil level abnormal	
	• Hydraulic oil level abnormal	
	• Air cleaner abnormally clogged	
If the following is detected, while grizzly feeder is in operation.		
(2)	• Excessive load on primary belt conveyor	If any of abnormalities listed at left takes place, the lamp goes on. (When the cause is removed, the lamp goes off)
	• Excessive load on crusher	
	• Excessive load on debris discharging conveyor	
	• Over feed sensor activated	
(3)	• Primary belt conveyor in raised (traveling) posture	The lamp goes on. (If the conveyor is in LOWER position, the lamp goes off)

ADDITIONAL WORKING LAMP



CAUTION

When installing additional working lamps, use an estimate that two more lamps are the maximum tolerable number in terms of halogen lamps (60W each) that are currently fitted to the machine.

Be sure to follow this guideline, when installing an additional working lamp, because any more lamps will cause an excessive current, blow a fuse and burn the wiring.

For illumination this machine has two head lamps and a working lamp.

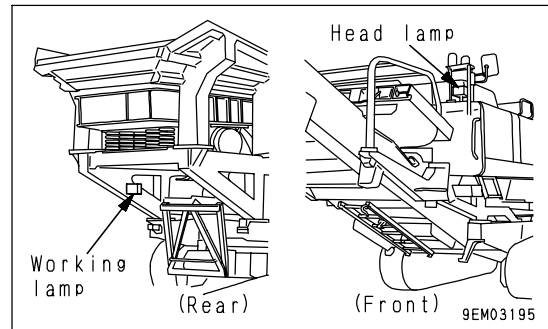

When installing an additional lighting fixture on the machine, use a connector (A) for an additional lighting provided beside the hopper frame.

(Connector No FCN-E21)

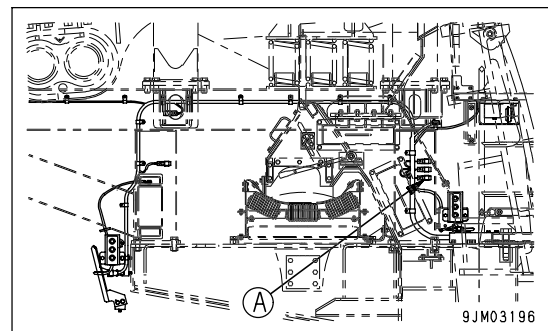

FUSIBLE LINK

When the starter motor does not function, after turning the engine starting switch ON, the fusible link on the wiring may be broken. In that case open the cover of the batter box located on the right side of the machine, and check and replace it.

REMARK

A fusible link refers to the large-sized fuse wiring installed in the high current flow portion of the circuit to protect electrical components and wiring from burning, in the same way as an ordinary fuse.

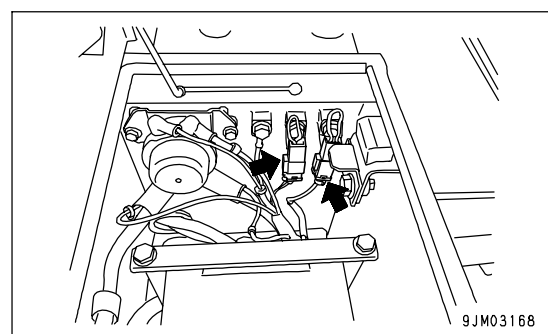

CONTROLLERS

A governor pump controller and an LX controller are installed on the machine.

NOTICE

- Take care so that these controllers do not get wet with water or mud. It may cause a failure.
- If anything unusual has developed on any of the controllers, do not attempt to overhaul it by yourself, but call your Komatsu distributor for check and repair.
- Do not open the door inside the main control box in a wet weather condition. If it has to be opened by all means for some reason or other, take care so that dust or rainwater will not get in the box.

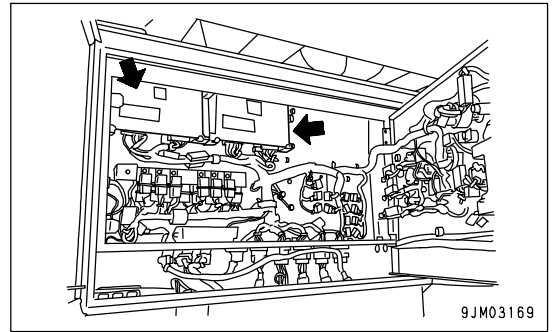

FUSE

FUSE BOX

NOTICE

Before replacing a fuse, be sure to turn off the starting switch.

The fuses protect the electrical equipment and wiring from burning out.

If the fuse becomes corroded, or white powder can be seen, or the fuse is loose in the fuse holder, replace the fuse.

- When replacing the fuses, use ones with the same capacity.

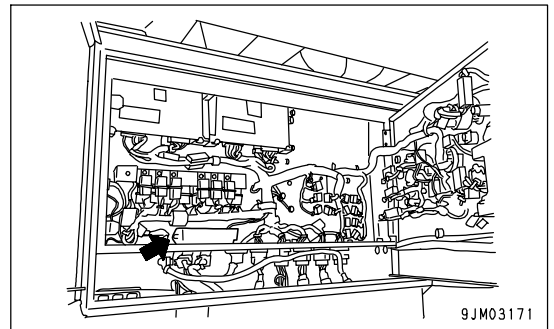

FUSE CAPACITY AND NAME OF CIRCUIT

No.	Capacity	Name of Circuit
(1)	25A	Power source for GP controller and LX controller
(2)	10A	Power source for CP controller and solenoid
(3)	20A	Power source for LX controller and solenoid
(4)	30A	Working lamp
(5)	10A	Revolving working lamp
(6)	20A	Horn
(7)	10A	Optional equipment (Radio control unit)
(8)	10A	Travel alarm
(9)	30A	Optional appliance (Power Source)
(10)	10A	Key switch signal
(11)	30A	Additional working lamp
(12)	10A	Spare
(13)	10A	Power source for instrument panel, alarming buzzer
(14)	10A	Engine starting switch
(15)	10A	Spare

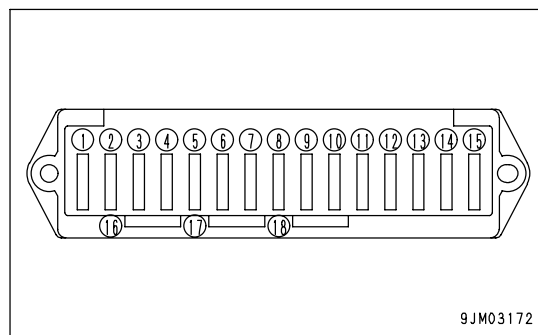

TOOL BOX

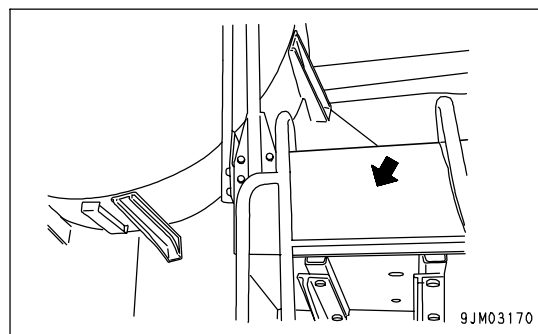

OPERATION

CHECK BEFORE STARTING ENGINE



WARNING

Ensuring the safety at the job site

- Before starting the work, confirm that there is no danger in the job site.
- Before starting the job, level the ground as evenly as possible.
- When working on a public road, ensure the safety for both pedestrians and passing vehicles by manning a guide and putting up a fence around to turn the area off-limit.

WALK-AROUND CHECK



WARNING

Inflammables piled on the intensely heated engine parts like an exhaust muffler and on the battery or fuel and oil leakage can cause a fire on the machine.

Make a thorough check, and if something unusual is found, be sure to fix it or inform it to the komatsu distributor in your territory.

Before starting the engine, walk around the machine and look at the underside of chassis for anything unusual like loose bolts and nuts, leakage of fuel, oil and coolant. Also check the condition of the work equipment and the hydraulic system.

Also check for loose wiring, play, and collection of dust at places that reach high temperature.

Be sure to check the items listed here before starting the engine for the day's work.

1. Check for damage, wear and play of the work equipment, hydraulic cylinders and hoses
Check the work equipment, the hydraulic cylinders and hoses for any damage, wear and play. If any of them is found, fix it.
2. Removing dust from the engine parts and the radiator
Walk around the engine and the radiator to check if dust is piled up on any of them. Remove it, if any.
3. Check for coolant and oil leakage around the engine
Check for oil leakage from the engine and coolant leaks from the cooling system. If any problem is found, repair it.
4. Inspection of the operator's platform
Check around the operator's platform to see if there is any parts or tool left, and put it back or move to the specified place.
Furthermore inspect the platform floor, control levers, handrails, step, etc. for mud, oil, snow stuck to them, and remove them, if any.
5. Inspection of the lamps for smudge
Inspect the surface of the lamps for any smudges, and wipe them out, if any.
6. Inspection of the head lamps and the working lamp
Inspect the head lamps and the working lamp to determine that they are suited to the work, and if not, replace them.
7. Check for oil leakage from hydraulic equipment, hydraulic tank, hoses, and joints
Check for oil leakage. If any abnormality is found, repair the area where oil is leaking.
8. Check of the undercarriage parts
Check track shoe, sprocket, idler, guard for damage, wear, loose bolts, or leakage of oil from rollers, etc.
Repair them if any trouble is found.

9. Check of the handrails and steps

Check the handrails and steps for any damage or loosened bolts, and repair the damaged part and tighten the loosened bolts, if any.

10. Inspection of damage on the gauges and monitors and looseness of the bolts

Inspect if no damage has occurred on the gauges and monitors, and if any abnormality is found, replace it. At the same time wipe out the smudges on their surface.

11. Check and cleaning of the rear view mirrors

Check the rear view mirrors for breakage, and replace any broken one. Clean the surface of each mirror and adjust the angle so that the rear view can be seen clearly from the operator's platform.

12. Check of outer cover mounting bolts

Check the outer cover mounting bolts for looseness, and tighten any loosened bolt.

CHECK BEFORE STARTING

CHECKS AND CLEANING OF RADIATOR FINS AND OIL COOLER FINS



WARNING

For the cleaning and check, stop the engine without fail and confirm that the fan is not rotating, and carry out the work.

NOTICE

When using compressed air for cleaning, blow it keeping some distance to avoid damaging the fins. Damage on the fins can cause water leakage and overheating. In a dusty job site, check the fins every day, regardless of the maintenance interval.

1. Take out a maintenance ladder (1) stored under the primary belt conveyor.

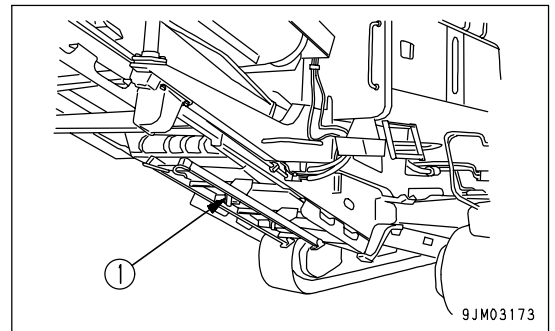

2. Hook the top of the ladder to the piping provided below the door at the left side of the machine.

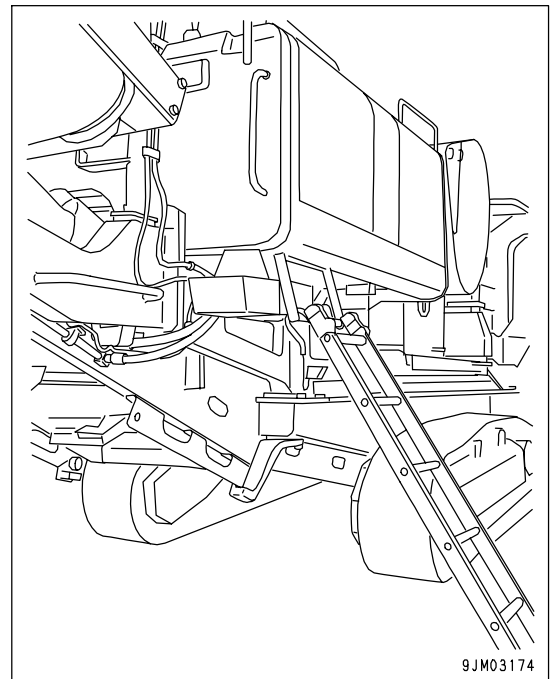

3. Open the door on the left side at the rear part of the machine.
4. Blow off mud, dirt, leaves, etc. caught in the radiator fins and oil cooler fins(2) with compressed air.
Steam or water may well be used instead of compressed air.

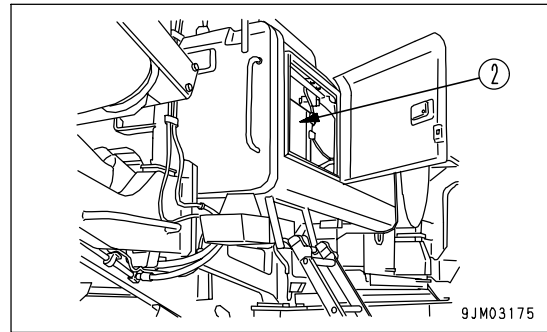

CHECK COOLANT LEVEL, ADD COOLANT



WARNING

While temperature of the cooling water in the radiator is still high, do not open the radiator cap. Boiling water may spurt out. Furthermore, when opening the radiator cap, loosen the cap slightly to relieve the internal pressure.

1. Check with a water level sight gauge (G) provided on the fuel tank side cover on the left side of the machine that the cooling water level is between the FULL and LOW marks in the sub-tank (shown in the figure at right). If the cooling water is not sufficient, open a cover on top of the sub-tank and add it up to the FULL level through the water filler.
2. After adding coolant, tighten the cap securely.
3. If the sub-tank is empty, check for water leakage, and check the water level in the radiator. If the cooling water is insufficient, supply water to the radiator and then to the sub-tank.

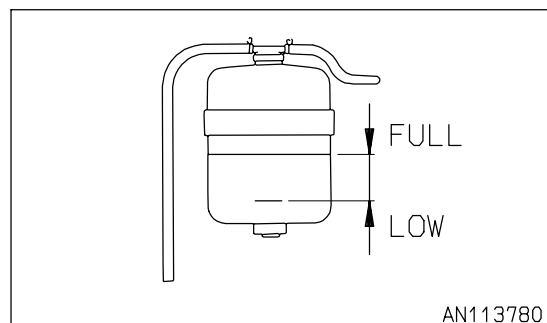
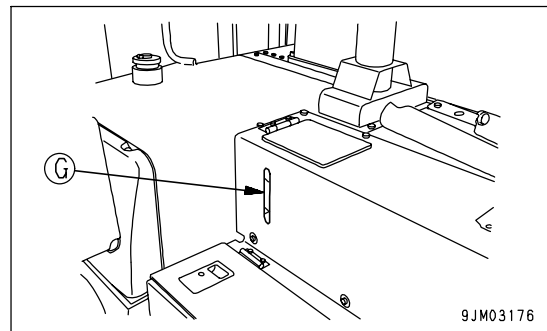

CHECK OIL LEVEL IN ENGINE OIL PAN, ADD OIL

**WARNING**

Parts and oil are at high temperature immediately after the engine is stopped and may cause serious burns. Wait for the oil temperature to go down before performing this operation.

1. Open the engine hood on the machine.
2. Remove dipstick (G), and wipe the oil off with a cloth.
3. Fully insert dipstick (G) into filler pipe (F), then remove it.

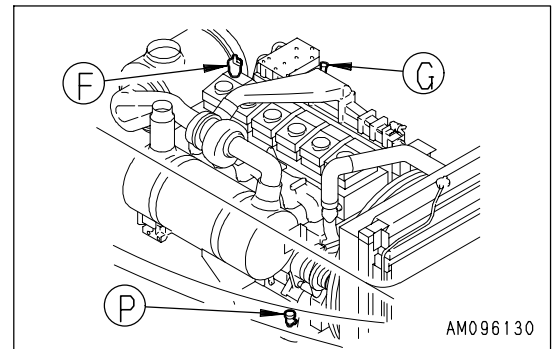

4. The oil level should be between the H and L marks on dipstick (G).
If the oil level is below the L mark, add engine oil through oil filler (F).
5. If the engine oil level is higher than the H mark, drain the excess through drain plug (P), and check the level again.
6. If oil level is correct, securely tighten the oil filler cap and close the engine hood.

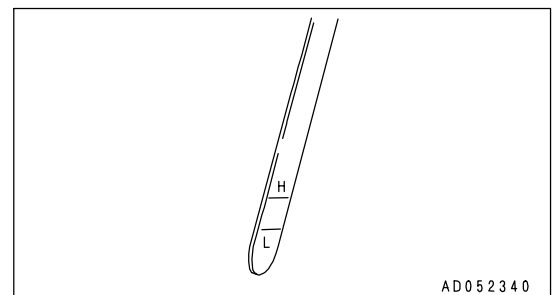
**REMARK**

When checking the oil level after the engine has been operated, wait for at least 15 minutes after stopping the engine before checking.

If the machine is at an angle, make it horizontal before checking.

CHECK FUEL LEVEL, ADD FUEL



WARNING

When adding fuel, never spill the fuel or let it overflow. It will cause fire.

If any fuel has spilled, wipe it up completely. If fuel has spilled over soil or sand, remove that soil or sand.

Fuel is highly flammable and dangerous. Never bring flames near fuel.

- 1. Unscrew fuel filler cap (F) on the fuel tank.

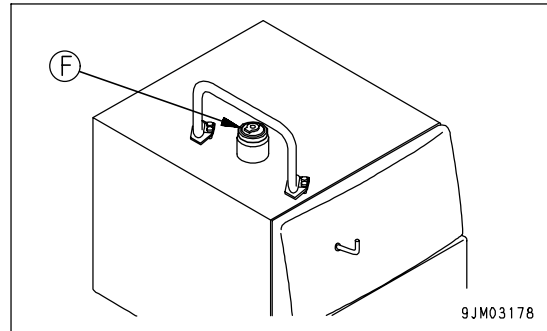

- 2. When fuel filler cap (F) is opened, float gauge (G) comes up in proportion to the remaining fuel level in the tank. Check that the fuel tank is full. Inspect the fuel level both visually and with float gauge (G).
- 3. If the fuel tank is not full, add fuel through the fuel filler up until float gauge (G) reaches the highest point.

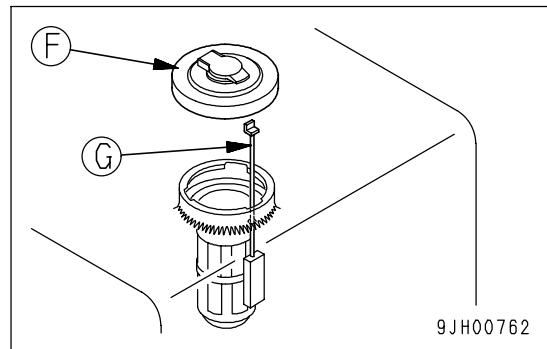

Fuel tank capacity: 605 liters (159.84 US gal)

- 4. When refueling, hang a refueling gun on the hook on the fuel tank cover and climb up to the top of the machine by a ladder on the right side of the machine. When refueling preparations are complete, pick up the refueling gun and start refueling.
- 5. When refueling is finished, push float gauge (G) straight down along the fuel filler cap (F), then tighten fuel filler cap (F) securely, taking care so that float gauge (G) will not get caught on claw (2) of the cap.

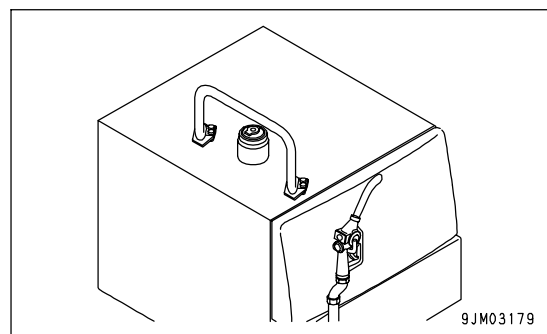

REMARK

If breather hole (1) in the cap is clogged, the pressure in the tank will drop and fuel will not flow. Clean the hole from time to time.

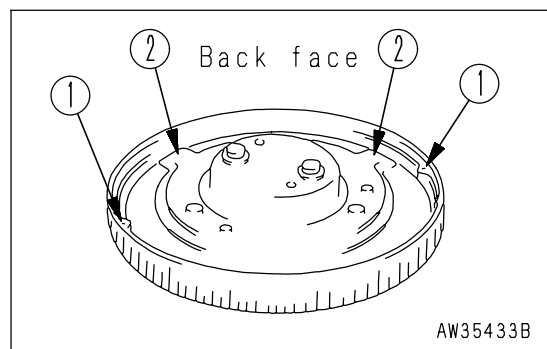

CHECK OIL LEVEL IN HYDRAULIC TANK, ADD OIL

! WARNING

- When removing the oil filler cap, oil may spurt out, so stop the engine and wait for the oil temperature to go down, then turn the cap slowly to release the internal pressure before removing the cap.
- If oil has been added to above proper range, stop the engine and wait for the hydraulic oil to cool down, then drain the excess oil from the drain plug.

NOTICE

Be sure to park the machine on the level and solid ground.

1. Check oil level sight gauge (G). If the oil level is between the H and L lines, the oil amount is appropriate.

NOTICE

Do not add oil if the level is above the H line. This will damage the hydraulic equipment and cause the oil to spurt out.

2. If the oil level is below the L line, add oil through oil filler (F) on top of the hydraulic oil tank.

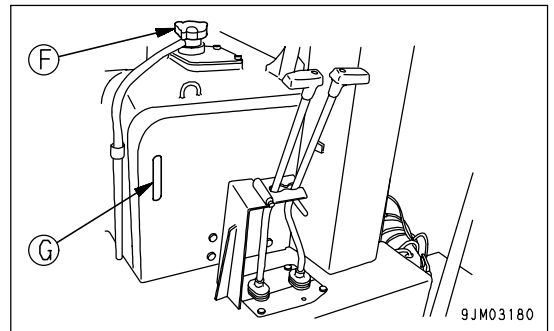

REMARK

Since the oil level varies with oil temperature, keep the following in mind when checking the oil level.

- Oil level is near the L line before starting the engine.
(Oil temperature: 10 to 30°C (50 to 86°F))
- Oil level is near the H line while the engine is running normally.
(Oil temperature: 50 to 80°C (122 to 176°F))

CHECK AIR CLEANER FOR CLOGGING

1. Confirm that the air cleaner clogging monitor of the monitor panel does not flash.
2. When the monitor lamp flashes, either clean the element or replace it with new one immediately.
For cleaning the elements, see the section, "CHECK, CLEAN AND REPLACE AIR CLEANER ELEMENT (PAGE 4-25)".

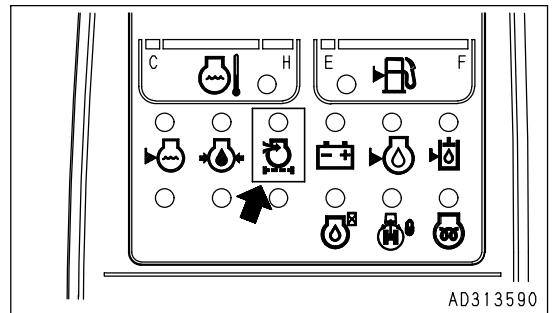

CHECK ELECTRIC WIRING**WARNING**

- If the fuses frequently blow or if there are traces of short circuits on the electrical wiring, locate the cause immediately and carry out repairs, or contact your Komatsu distributor for repairs.
- If flammable materials (dead leaves, twigs, dry grass, etc.) accumulate around the battery, they will cause fire, so always remove such material immediately.
- Keep the top surface of the battery clean and check the breather hole in the battery cap. If it is clogged with dirt or dust, wash the battery cap to clean the breather hole.

Check for damage and improper capacity of the fuses, and any sign of disconnection or short circuit in the electric wiring. Check also for loose terminals and tighten any loosened ones.

Pay special attention to the wiring of the battery, starter and alternator, when checking.

Be sure to check that there are no piles of inflammables on and around the battery and remove them, if any.

For the checkup and repairs of troubles in the battery, consult the Komatsu distributor in your territory.

CHECK FUNCTION OF HORN

1. Turn the starting switch to the ON position.
2. Confirm that the horn sounds immediately when the horn button is pressed.

If the horn does not sound, contact your Komatsu distributor for repair.

ADJUSTMENT OF REAR VIEW MIRROR

Loosen the bolts securing the square rear view mirror (1) and those securing the round rear view mirror (2), and then adjust the mirror positions so that there will be no blind spot at the rear and left side of the machine and a better view will be available.

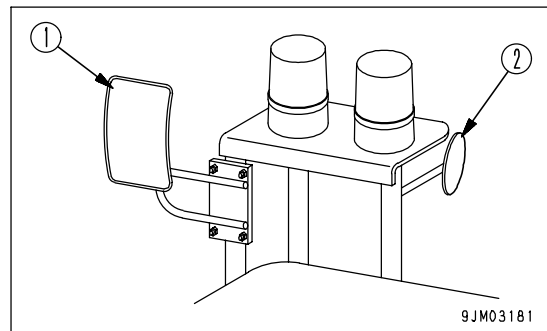

CHECK OF JAW CRUSHER

No.	Check Item	Check Interval			Method	Standard Value	corrective Measure	
		Daily	weekly	Monthly				
1	Abnormal vibration of machine	○			Visual check	-	Stop and check. Check crusher for loosened securing bolts.	
2	Abnormal noise from machine	○			Hearing check	-	Stop and check.	
3	Flow of crushed debris	○			Visual check	-	Check for excessive feeding. Limit feeding amount. Adjust grizzly feeder setting amount dial and crusher charge setting dial.	
4	Abnormal heating of bearings	○			Feeling check	Ambient temperature + 40°C	Stop and check, if temperature is abnormally high. Check greasing amount is proper.	
5	Abnorma noise from bearings	○			Hearing check	None	If any abnormality is noticed, stop and check. Repair or replace.	
6	Loosening of bolts	○			Spanner	No looseness	Retighten.	
7	Wear of fixed jaw plate	○			Visual check	-	Reverse or replace.	
8	Wear of swing jaw plate	○			Visual check	-	reverse or replace.	
9	Wear of cheek plate	○			Visual check	-	Replace.	
10	Wear of protector	○			Visual check	-	Replace.	
11	V-belt	Degree of tension	○			Tension meter	-	Check tension.
		Slip	○			Visual check	-	Pay attention to insufficient tension and misalignment.
		Wear and damage	○			Visual check	-	Replace.
12	Adding grease	○			Grease pump	-	Add.	

CHECK OF BEAR-LOC CYLINDER FOR LOCKING FORCE

Confirmation of locking force before starting operation

**CAUTION**

- After adjusting the clearance at the outlet of the crusher jaw, be sure to carry out a trial operation under the trial conditions of engine revolution at low idling and crusher revolution at MIN and confirm that there is no abnormal noise from around the toggle block.
- When inserting shim plates, confirm the total number and thickness of the right and left shims to ensure the identical shim plate thickness on both sides.
Should the shim plate thickness differ between the right and the left sides, there would be a critical damage to the crusher main body.

For some time after an operation is started with load, the locking force may be reduced on account of insufficient contact of the shims or fine foreign objects caught between the shims. When adjustment was made of the clearance at the outlet of the crusher due to the wear on the swing jaw plate and fixed jaw plate, tighten the shim plates (toggle block) every 30 minutes of operation until no backlash is confirmed.

Checking method

Hit the shim plates and the toggle block pins with a hammer to see if there is any backlash.

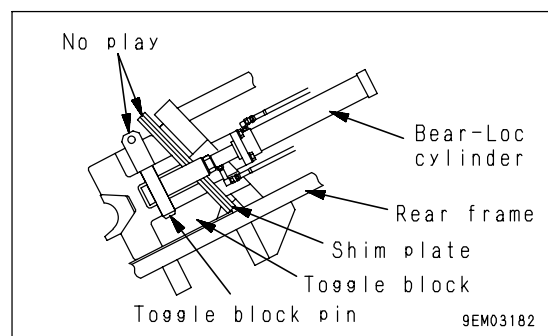
**REMARK**

If the backlash can be settled by no means, remove all the shims once by pushing the toggle block to the extreme front end, following the same procedure for the jaw crusher outlet clearance adjustment, and then blow them with an air or water gun to remove foreign objects.

CHECK OF PRIMARY CONVEYOR

 **WARNING**

When correcting zigzag movement of the primary conveyor, carry that out with the adjust bolts.

1. Foreign materials such as stones, gravel, wire chips, iron and steel bar chips, etc. are likely caught in various parts of the primary conveyor. Check for them inside the conveyor, between the rollers and the belt, inside the hopper rubber and the belt as well as inside the return roller guides. If found, remove them.

2. Zigzag movement of conveyor belt

- If the conveyor belt shows a zigzag movement while running, correct it by turning the adjusting bolts provided on the right and left sides of the belt, as shown in the figures (a) and (b) at right.
- In case the adjustment cannot be perfected by adjusting only the adjusting bolts at the tail pulley, try to correct it with the bolts securing the carrier roller bracket and return roller bracket, as they are also so designed as to allow this adjustment.

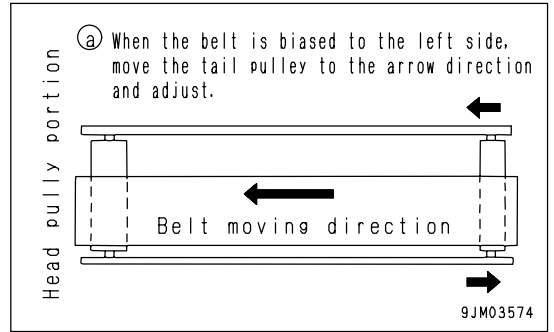

3. Check that there is no damage nor cut on the belt rubber.

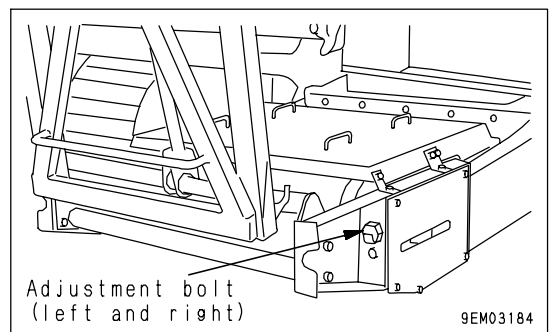
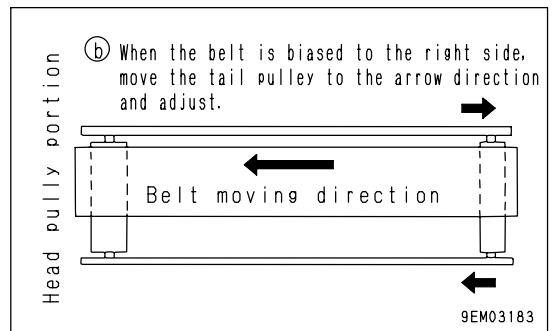

CHECK OF GRIZZLY FEEDER

NOTICE

Park the machine on the level and solid ground, then carry out this check.

1. Check the drive motor for oil leakage.
2. Check the grizzly bars for clogging.
3. Check that the oil level in the vibrator case is in the middle of the oil level gauge.

CHECK OF JAW CRUSHER AND RELATED ACCESSORIES

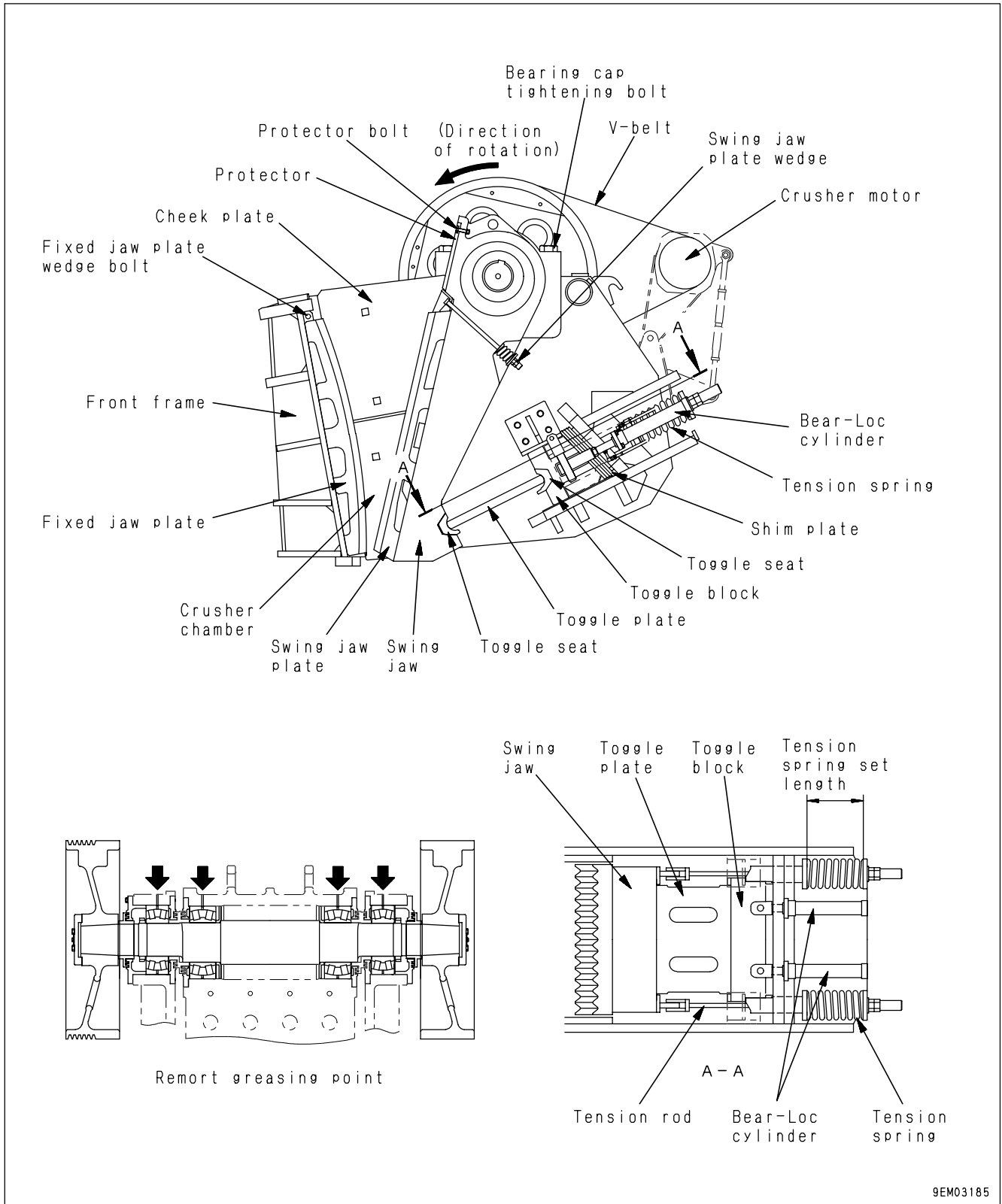

9EM03185

- Check whether there are any foreign materials in the crusher chamber.
- Check that each bolt is tightened sufficiently.
Particularly check the main body securing bolts, toggle tension bolts of the toggle block, and wedge bolts of the fixed jaw and swing jaw with an extra care.
- Check that the crusher rotates in the right direction.
- Check that the spring set length is proper.
The right spring set length is as indicated below.

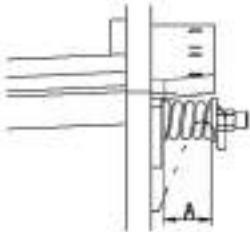
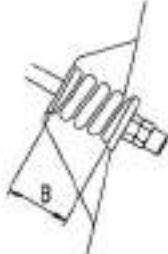
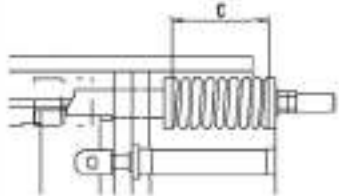
Spring No.	A	B	C
Part name	Fixed jaw pleate wedge bolt spring	Swing jaw plate wedge bolt spring	Tension spring
Set length	100 ⁺² mm	100 ⁺² mm	338 ⁺² mm
Free length	120mm	120mm	400mm
Diameter	φ 19mm	φ 19mm	φ 30mm
Shape of spring			

When measuring the tension spring set length, make sure that measurement is made at four points 90° apart from each other on the periphery and that the spring is upright.
If the actual spring set length is longer than the specified dimension by more than 3 mm (0.118 in), turn the spring to change the spring seat and tighten it again.

 **CAUTION**

If the spring set length is longer than the above dimension;

- The toggle plate and the toggle seat beat each other, thereby shortening their lives.
- The toggle plate may fall off.

The tension spring set length is shorter than the above dimension;

- The tension rod and the tension spring may be broken.
- If the V belt tension is not proper, the V belt may slip off, when the crusher is started or stopped, causing the V belt life to be extremely shortened.

- Are the V belt set correctly?

Standard tension of crusher driving V belts (Average value of 6 V belt tension)

Open a V belt inspection window provided on the left flywheel cover of the crusher. Take measurement of V belt deflection l and load P , using a designated potentiometer and adjust them to the specified tension.

Model		BR550JG-1
Deflection (l)		17.0 mm (0.7 in)
Adjustment of position of load setting ring	P value when belt is new	124.5 N (12.7 kgf)
	P value when belt is retightened	108.9 N (11.1 kgf)
	P value at lower limit	85.0 N (8.7 kgf)

V belt tension adjusting method

The V belt tension may be changed by adjusting the turnbuckle located behind the crusher motor. After the adjustment, be sure to tighten the lock nut.

Method for adjusting V-belt tension

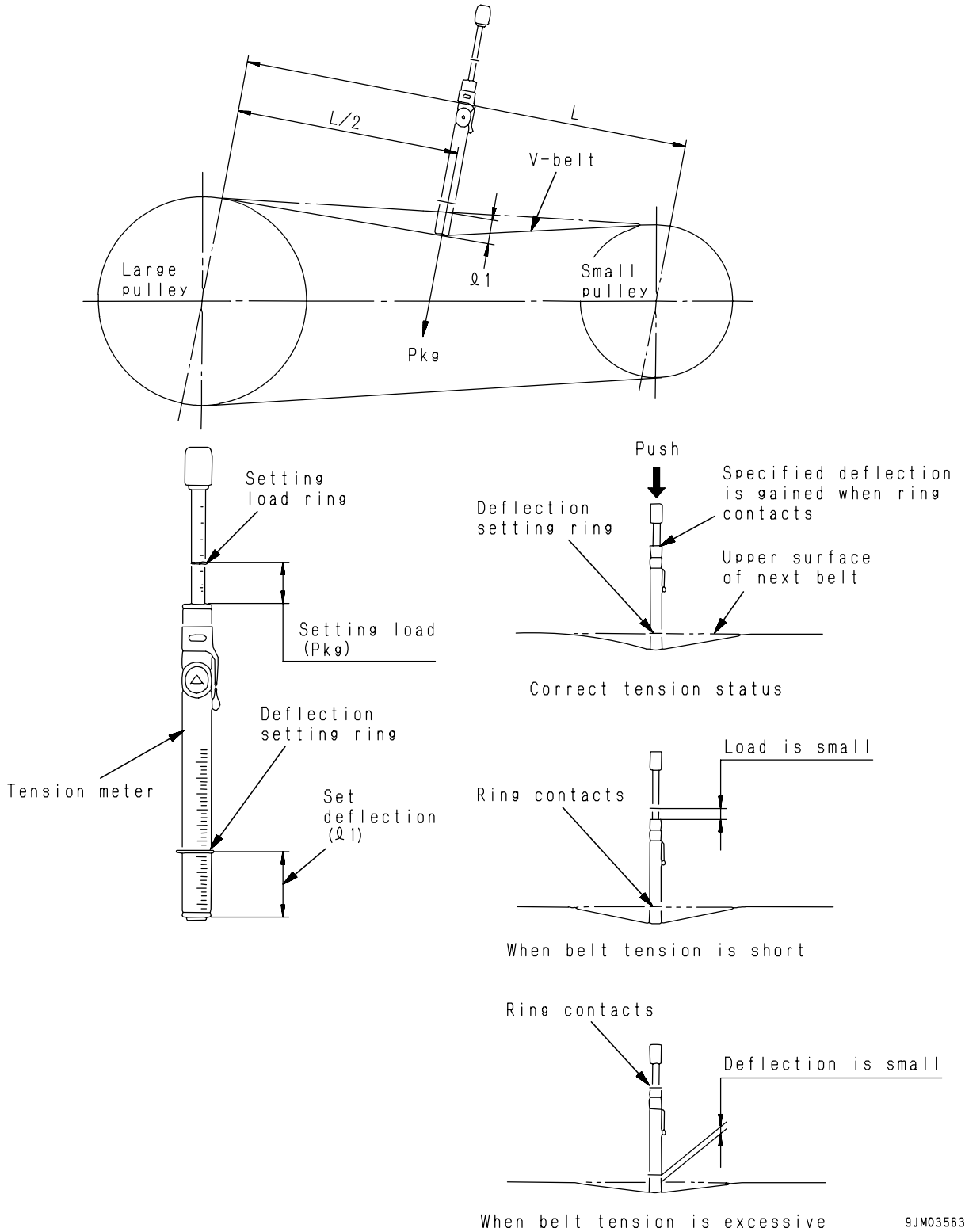

OPERATION AND CHECK BEFORE STARTING ENGINE



WARNING

A careless touch on the travel control lever may start the machine all of sudden.

Before leaving the operator's platform, be sure to set the operation mode selector switch to the "OPERATION" position.

1. Confirm that the operation mode selector switch (1) is at the "WORK" position.
2. Confirm that all the emergency switches are released. They are located in the main control box, upper control box and on the left and right sides of the machine (at 11 points in total).
3. Turn the lamp switch (2) to confirm that the head lamps, working lamps and panel lamps turn on. If any of them does not turn on, a blown bulb or disconnected wiring is suspected, so ask the Komatsu distributor in your territory to repair the failure.

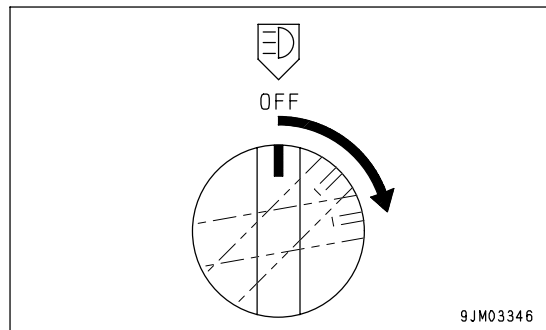
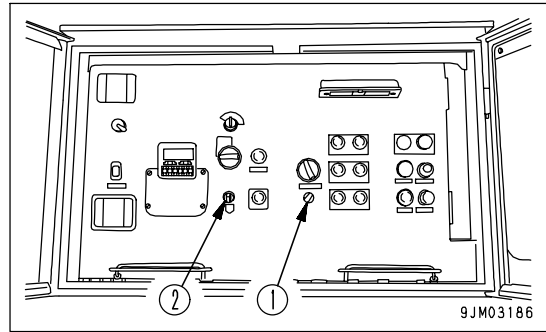

STARTING ENGINE

NORMAL STARTING

 **WARNING**

- Look out to see if there are workers or bystanders or any obstacles in the surrounding and start then work after sounding a horn.
- Never use liquid engine starting aid in the engine startup, because it may explode.

NOTICE

- Before starting the engine, check that the fuel control dial is at the low idling (MIN) position.
- Do not crank the starting motor continuously for more than 20 seconds. If the engine does not start, wait for at least 2 minutes before trying again.

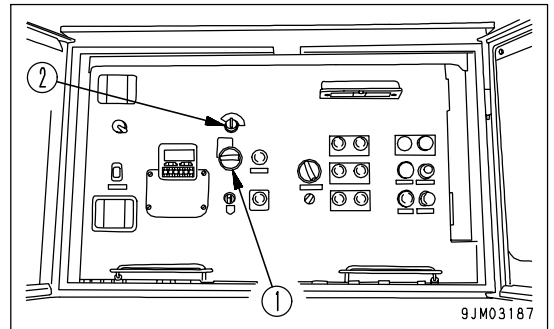

1. Turn the fuel control dial (1) to the left end, to the low idling (MIN) position.

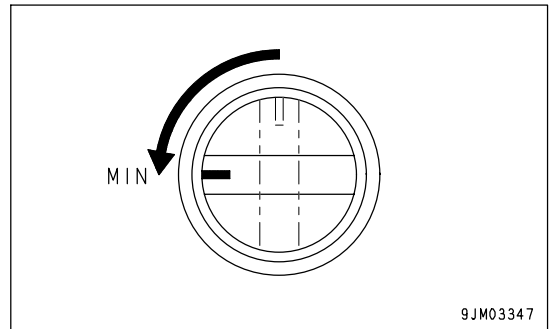

2. Turn the starting switch (2) to the START position and the engine starts running.

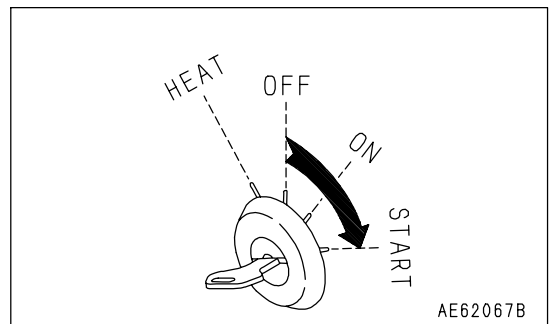

3. When the engine starts, release the key in starting switch (2). The key will return automatically to the ON position.

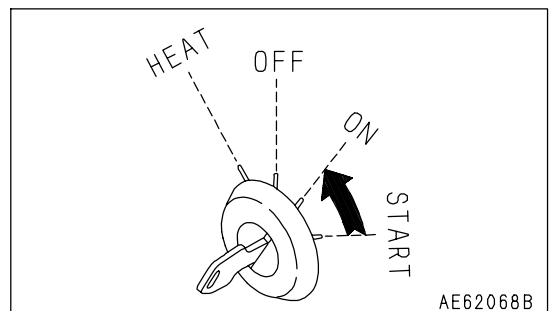

STARTING IN COLD WEATHER

WARNING

- Check that there are no persons or obstacles in the surrounding area, then sound the horn and start the engine.
- Never use starting aid fluids as they may cause explosions.
- Exhaust gas is toxic. When starting the engine in confined spaces, be particularly careful to ensure good ventilation.

NOTICE

Do not keep the starter motor running for more than 20 seconds continuously.

If the engine does not start, wait for about two minutes and begin with the step 2. again.

Follow the advices on the cold starting below in a low ambient temperature.

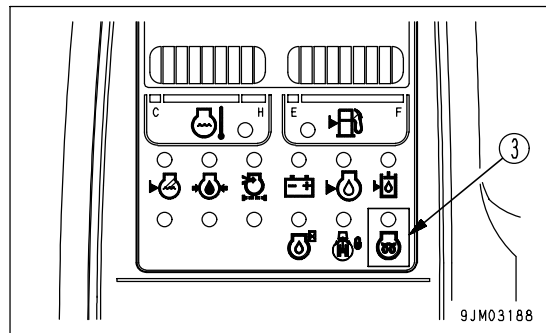
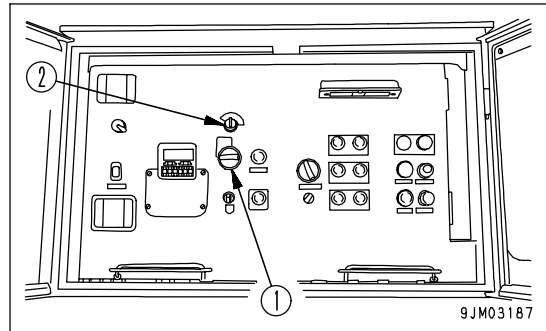

1. Turn the fuel control dial (1) to the low idling (MIN) position.

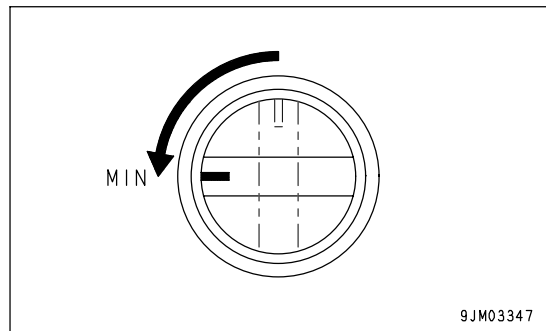

2. Hold the starting switch (2) at the HEAT (preheating) position, while confirming the preheater monitor (3) lamp is on.
 The preheater monitor (3) lamp begins to flash in about 30 seconds, indicating that preheating process is finished.

REMARK

The monitor and gauge also light up when the key is at the HEAT position, but this does not indicate any abnormality.

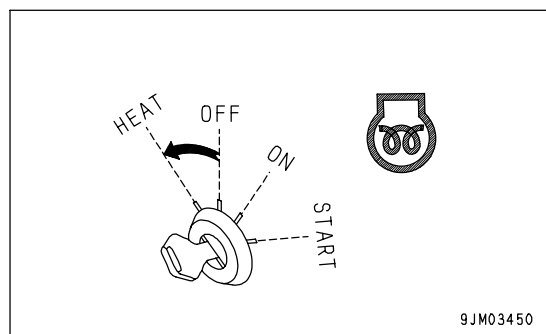

3. When preheating monitor (3) flashes, turn the key in starting switch (2) to the START position to start the engine.

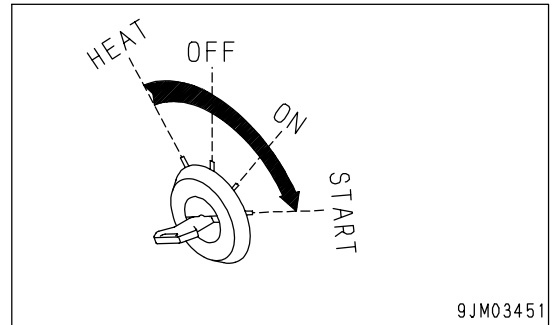

Ambient temperature	Preheating time
Over 0°C (32°F)	-
0°C to -10°C (32°F to 14°F)	Approx. 20 seconds
-10°C to -20°C (14°F to -4°F)	Approx. 30 seconds

4. When the engine starts, release the key in starting switch (2). The key will return automatically to the ON position.

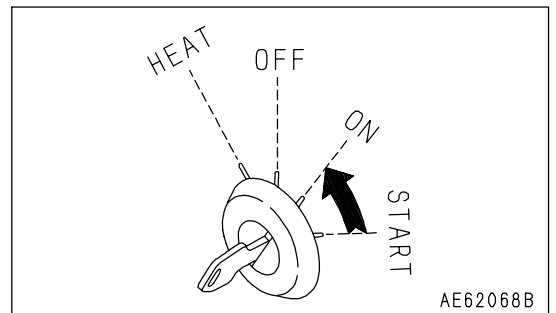

OPERATIONS AND CHECKS AFTER STARTING ENGINE

BREAKING IN THE NEW MACHINE

NOTICE

Before operating the machine for the first time, check that there is coolant in the radiator. If the machine has been delivered without coolant in the radiator, run water through the system to flush the system thoroughly, then fill the radiator with coolant.



CAUTION

Your Komatsu machine has been thoroughly adjusted and tested before shipment. However, operating the machine under severe conditions at the beginning can adversely affect the performance and shorten the machine life.

Be sure to break-in the machine for the initial 100 hours (as indicated by the service meter).

During break-in operations, follow the precautions described in this manual.

- Idle the engine for 5 minutes after starting it up.
- Avoid operation with heavy loads or at high speeds.
- Immediately after starting the engine, avoid sudden starts, sudden acceleration, unnecessary sudden stops, and sudden changes in direction.

WARMING UP OPERATIONS



WARNING

- **Emergency stop**
When a failure or something unusual takes place on the machine, turn the starting switch key to the OFF position, and the electrical system ceases to function and the engine stops. Then ask the Komatsu distributor in your territory for the inspection.
- If you try to operate the work equipment without sufficient machine warming-up, the work equipment may respond to an activated control lever or switch only slowly, or move against the operator's intention, or an automated operation does not function properly. Hence be sure to warm up the machine prior to starting the work. This particularly applies to the cold start, which requires sufficient machine warming-up.

NOTICE

- The right hydraulic oil temperature level is between 50 to 80°C. Even if it becomes unavoidable to start the work with the hydraulic oil temperature still at a low level, do so only after the temperature rises up to approx. 20°C. That practice helps extend the machine life.
- Refrain from jerky operation of the control levers and the work equipment, when the hydraulic oil temperature remains lower than 20°C.
- Do not try to accelerate the engine suddenly until after the engine warming-up is completed.
Do not run the engine either at low idling (low revolution) or at high idling (high revolution) for more than 20 minutes. Such a practice brings about an adverse effect not only on the environment but also on the internal mechanism of the turbocharger and the engine.
If the engine idling is required, either apply load on the engine every now and then or run the engine at a medium speed.

After starting the engine, do not immediately start operations. First, perform the following operations and checks.

1. Turn fuel control dial (1) to the midpoint between the low idling position and the full revolution position to keep the engine running at a medium speed and continue no load running for about five minutes.

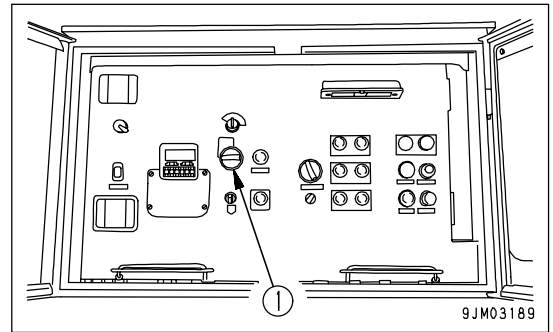

2. After warm-up run is completed, check gauges in the following condition. If any abnormality is found, repair it.
 - Engine water temperature gauge (2): Check that it is in the green range.
 - Fuel gauge (3): Check that it is in the green range.
 - Engine hydraulic pressure monitor (4): Check that the monitor lamp is off.
 - Battery charging monitor (5): Check that the monitor lamp is off.

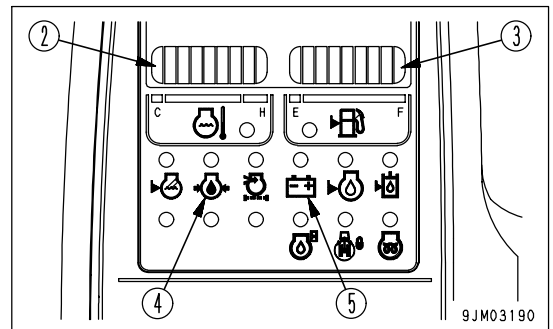

STOPPING ENGINE



WARNING

Do not stop the engine suddenly except in case of emergency, before it cools down. Otherwise durability of the engine components may be shortened. Sudden stop of the engine should be limited only to a case emergency.

Let the engine cool down gradually after the work and stop it thereafter.

1. Turn the fuel control dial to the low idling (MIN) position.
2. Run the engine at low idling for about 5 minutes to cool down gradually.

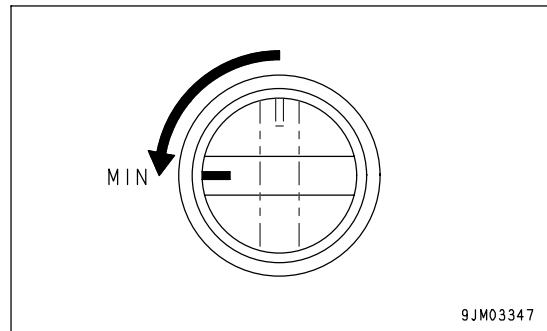

3. Turn the starting switch key back to the OFF position, stop the engine and pull out the key.

REMARK

- When the engine is overheated, do not stop it on the spot, but allow it to cool down gradually while running at a medium speed, and then stop it.
- If it is required to start the engine again, start it after approx. 30 seconds.

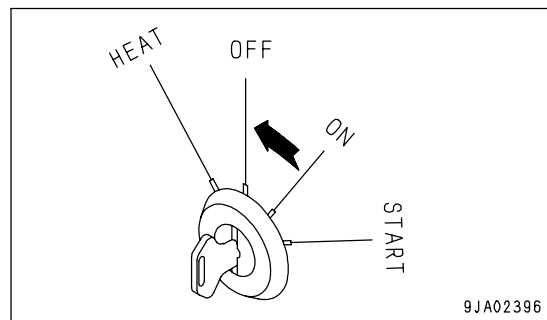

CHECK AFTER STOPPING ENGINE

1. Walk around the undercarriage, crusher, belt conveyor and machine covers to check for oil and water leakage. If any leakage or abnormality is found, fix it.
2. Fill the fuel tank.
3. Check the engine compartment for paper and debris. Clean out any paper and debris to avoid a fire hazard.
4. Remove any mud affixed to the undercarriage.

MACHINE OPERATION

MOVING MACHINE



WARNING

- When moving the machine, confirm the safety around and sound a horn.
- Do not allow people to come near the machine.
- Remove obstacles from the machine's traveling course.
- Support and steady yourself by holding to the travel control lever with one hand and the handrail with the other. If you push the travel control lever forward or pull it back toward yourself abruptly, the machine makes a jerky movement, giving a shock to you. Since that is dangerous, operate the travel control lever slowly and with good time allowance.

1. Start the engine.
2. Remove the belt conveyor bar off the mounting hook for work by depressing the belt conveyor raising switch (1) on the belt conveyor raising and lowering operation panel.
3. Raise the belt conveyor by depressing belt conveyor raising switch (1) again, while holding up the belt conveyor stopper.

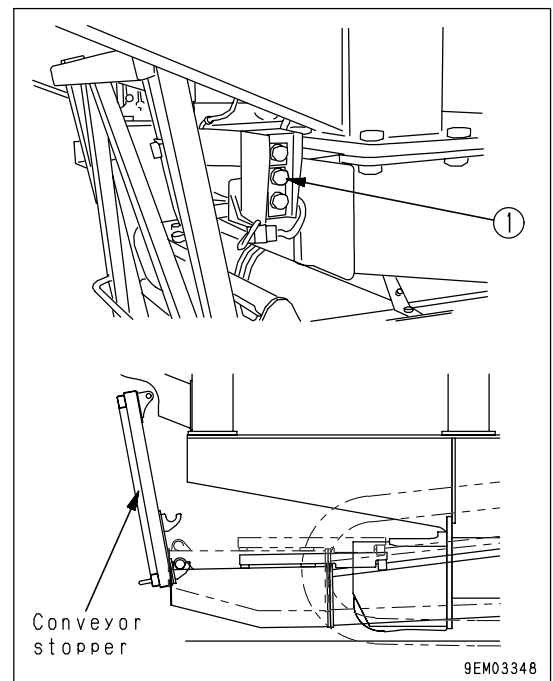

4. When the belt conveyor has been raised completely, keep the hands off the conveyor stopper, and then insert the mounting hook for travel under the conveyor bar.
5. Hang the belt conveyor bar to the mounting hook for travel without fail by depressing the belt conveyor lowering switch.

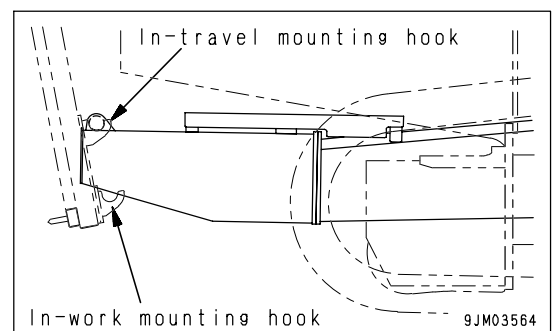

- 6. Turn operation mode selector switch (1) to the "TRAVEL" position and confirm that travel lock monitor (2) lamp is off.

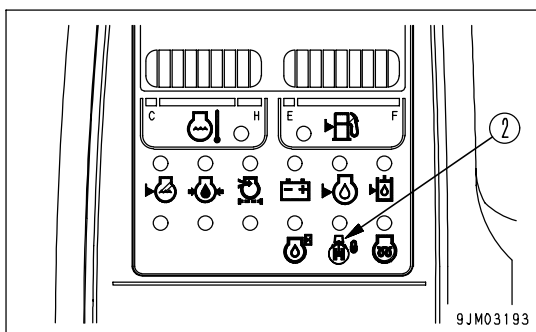
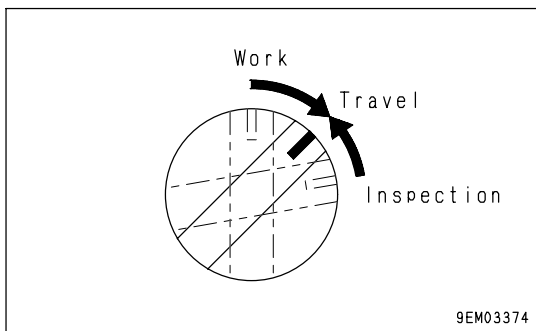
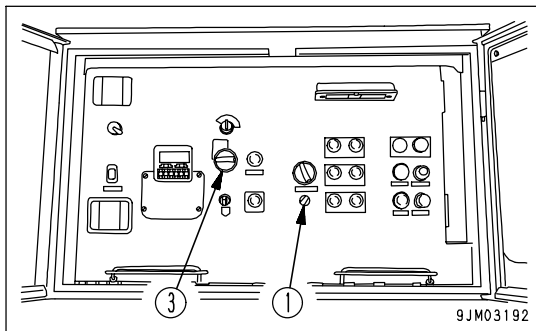

- 7. Raise the engine revolution by turning fuel control dial (3) in the direction of the full revolution.
- 8. Release the travel lever safety lock.

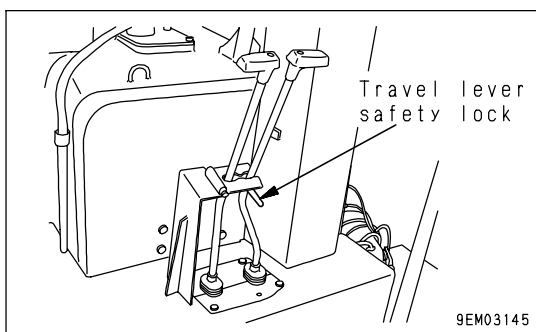

MOVING MACHINE FORWARD

1. Operate the right and left travel control levers (4) in the following manner.

- Push the levers forward slowly to start the machine.

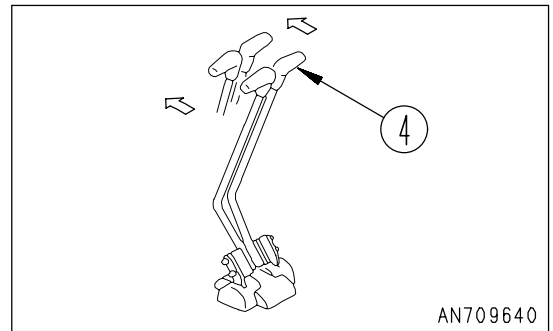
**MOVING MACHINE BACKWARD**

1. Operate the right and left travel control levers (4) in the following manner.

- Pull the levers (4) slowly toward yourself to start the machine.

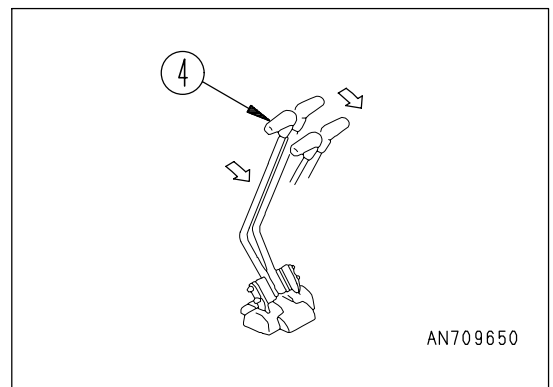

STOPPING MACHINE

WARNING

- A careless touch on the travel control levers will start the machine all of sudden and may cause a serious accident. When leaving the operator's platform, be sure to turn the operation mode selector switch to the "WORK" or "INSPECTION" position.
- Avoid to stop the machine abruptly. Try to stop it with as much allowance as possible.
- While the machine is at standstill, be sure to set the travel control lever safety lock to the LOCK position and turn the travel lock switch to the ON position.

1. Put the left and right travel levers (1) in the neutral position, then stop the machine.
2. Set the travel control lever safety lock.

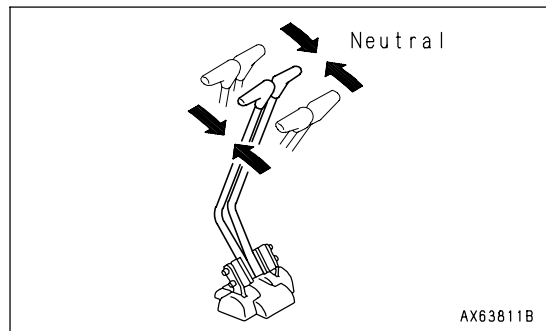
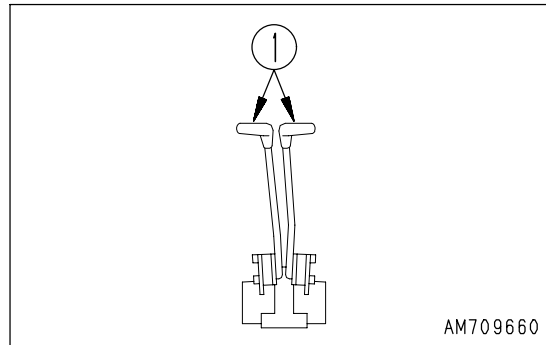

3. Turn operation mode selector switch (2) to the "WORK" or "INSPECTION" position.

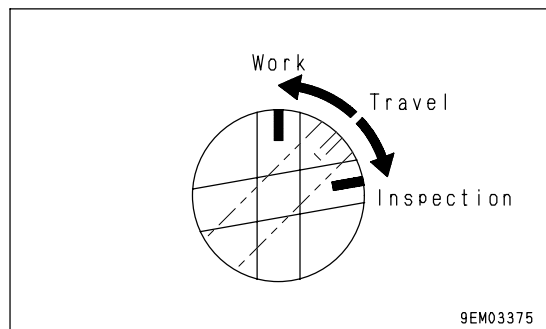
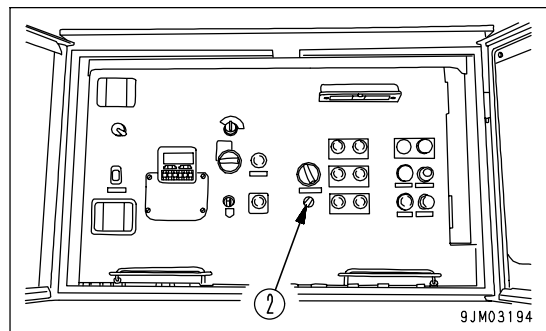

STEERING MACHINE

STEERING (CHANGING DIRECTION)

 **WARNING**

When the machine makes a turn, while traveling, you will be swayed to the right or left, so hold to the handrail with one hand to steady yourself and make a turn.

Use the travel levers to change direction.
Avoid sudden changes of direction as much as possible.
Especially when performing counter-rotation (spin turn), stop the machine before turning.
Operate two travel levers (1) as follows.

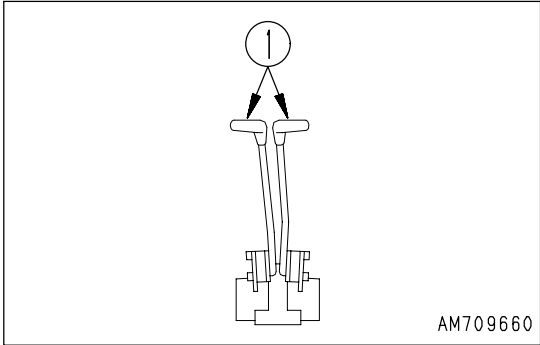

CHANGING DIRECTION OF MACHINE WHEN STOPPED

When turning to the left:
Push the right travel lever forward to travel left when traveling forward; and pull it back to turn left when traveling in reverse.

REMARK
When turning to the right, operate the left travel lever in the same way.

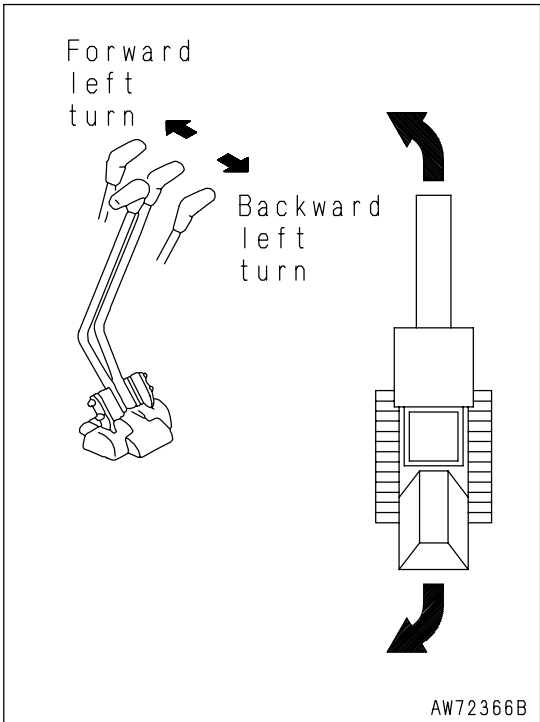

STEERING WHEN TRAVELING (BOTH LEFT AND RIGHT TRAVEL LEVERS OPERATED IN SAME DIRECTION)

When turning to the left:

If the left travel lever is returned to the neutral position, the machine will turn to the left.

REMARK

When turning to the right, operate the right travel lever in the same way.

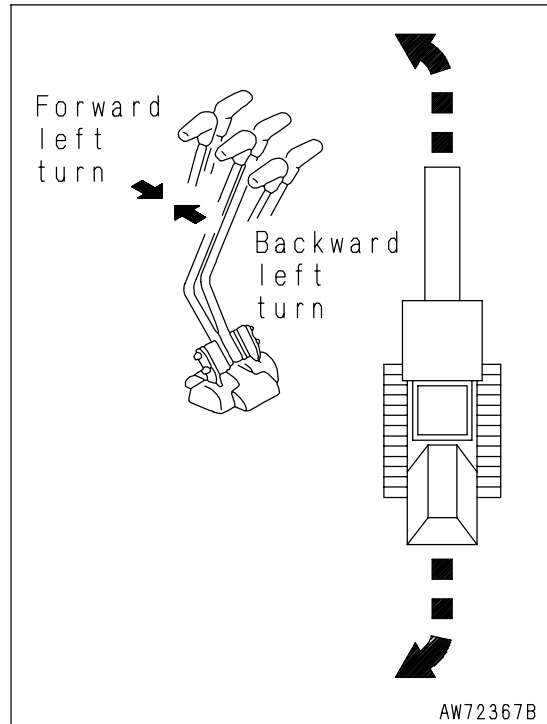

WHEN MAKING COUNTER-ROTATION TURN (SPIN TURN)

When using counter-rotation (spin turn) to turn left, pull the left travel lever back and push the right travel lever forward.

For making a pivot turn in the right direction, pull the right travel control lever toward yourself and push the left travel control lever forward at the same time.

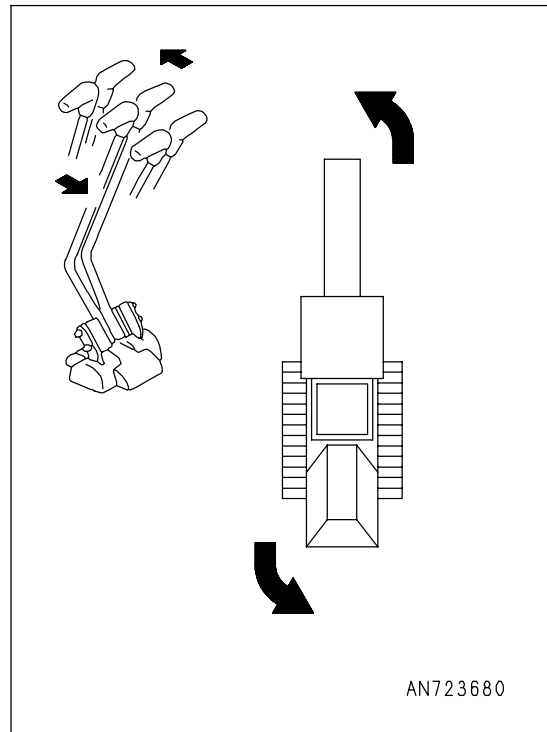

OPERATION OF WORK EQUIPMENT

STARTING JAW CRUSHER OPERATION

WARNING

- Park the machine on the level and solid ground and start the work.
- In order to avoid abnormal vibration, while the machine is in operation, check that the outermost track rollers are in firm contact with the ground at four points.
- When something unusual occurs on the machine, depress emergency stop switch (4).

A buzzer begins to sound then, and the jaw crusher, grizzly feeder, belt conveyor and optional working equipment (magnetic separator and side conveyor), if installed, will stop.

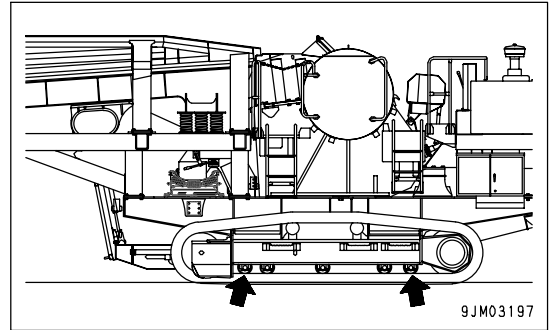

1. Lower the primary belt conveyor in the reverse order of the procedures for raising it.

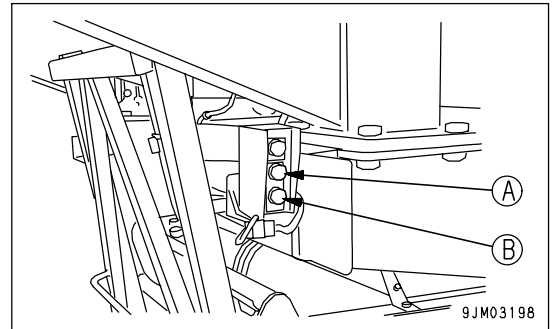

2. Turn belt conveyor starting switch (1) to the ON position and confirm that the belt is moving.
3. Turn crusher starting switch (2) to the ON position and confirm that the crusher is rotating.
4. Turn grizzly feeder starting switch (3) to the ON position and confirm that the feeder is in motion.

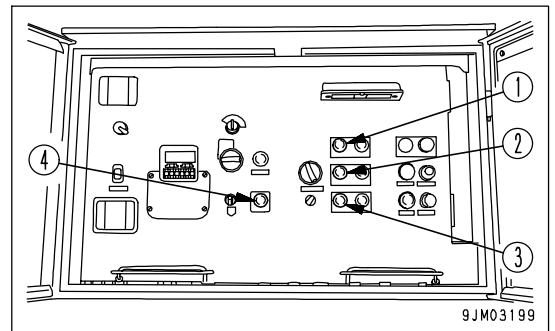

NOTICE

Run the engine at a low idling speed (low revolution) without any load for about five minutes.

5. After the machine warming-up, check if there is no bearing of abnormally high temperature or abnormal vibration.
Refrain from accelerating the engine suddenly until after the engine is sufficiently warmed up.
6. Turn the fuel control dial to the full speed (MAX) to raise the crusher revolution.
7. When the crusher revolution has risen sufficiently and becomes constant after turning the fuel control dial to the full speed, begin to feed debris to the crusher.
For restarting the crusher, release the emergency stop switch (depress it again to do so) and start it again following the procedures for crusher operation.

SETTING GRIZZLY FEEDER SPEED

Control the flow of debris to be crushed by adjusting the below mentioned grizzly feeder speed dial to the optimum condition according to the size of debris and the crusher revolution speed.

Grizzly feeder speed dial

This dial serves to control the speed of the grizzly feeder.

- (a) Minimum feeding speed (MIN): Turn the dial to the left end.
- (b) Maximum feeding speed (MAX): Turn the dial to the right end.

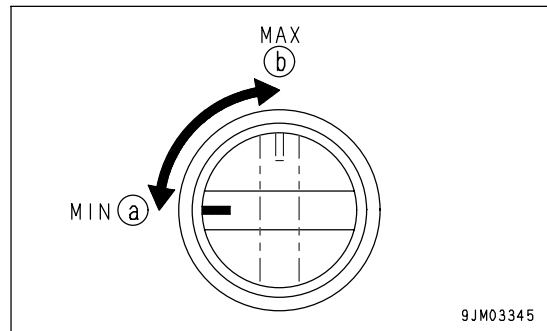

SETTING JAW CRUSHER SPEED

This dial serves to adjust the jaw crusher revolution speed.

- (1) Minimum revolution (MIN): Turn the dial to the left end.
- (2) Maximum revolution (MAX): Turn the dial to the right end.

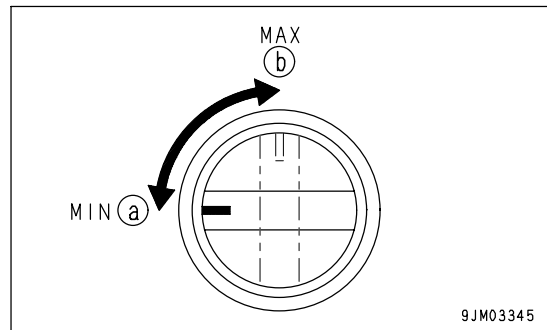

REGULATING CHARGING AMOUNT IN CRUSHER CHAMBER

(Crusher load setting dial)

- (1) Minimum charge: Turn the dial to the left end.
- (2) Maximum charge: Turn the dial to the right end.

The optimum charging rate for the crusher chamber is approx. 60%, considering the allowable work amount and wear on the consumable parts in the crusher chamber.

This machine is equipped with an automatic grizzly feeder stop function (excess charge preventive function). However the timing that the automatic feeder stops feeding is likely to vary according to the size and hardness of debris to be crushed and their muck content, resulting in the change in the actual charged amount in the crushing chamber.

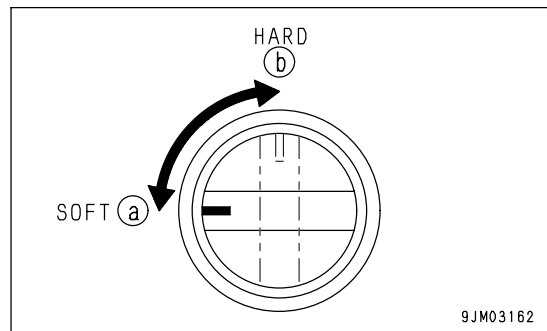

Keep watching the charging rate in the crushing chamber for about an hour after starting the work, and adjust the crusher charge setting dial to the optimum condition.

Guideline for dial adjustment

SOFT ←—————→ HARD

- Concrete debris
- Limestone
- Andesite
- Sandstone
- Granite
- Basalt
- Graywacke (Hard sandstone)

- Adjusting method for grizzly feeder speed, crusher speed and crusher chamber charging amount
 1. Basically the grizzly feeder speed and the jaw crusher speed must be set to the maximum speed (MAX).
 2. Visually inspect the charge amount in the crushing chamber, and if it is found more or less than 60%, adjust it by the crusher load setting dial.
 3. When crushing boulders or many big lumps contained in the debris, reduce the grizzly feeder speed as well as the jaw crusher speed for attaining higher work efficiency.
 4. Feed debris into the hopper, aiming at 50% charging of the hopper capacity, and good hopper efficiency is assured and debris screening efficiency can be also heightened.

REMARK

The grizzly feeder speed and the jaw crusher speed will also vary with the engine rpm.

LOAD ON CRUSHER

EXCESSIVE LOAD PREVENTIVE DEVICE



WARNING

As the debris in the crushing chamber decreases, the stopped crusher is activated automatically. Do not get close to the grizzly feeder while in operation.

This function is provided to detect load on the jaw crusher, after the grizzly feeder starting switch is depressed. When excess load is detected, it stops the grizzly feeder automatically, thereby suspending the feeding of new debris. At that time, a revolving working lamp (yellow) located at the rear of the machine begins to flash. When normal load on the jaw crusher is restored, it starts the grizzly feeder automatically, resuming the feeding of new debris. The revolving working lamp goes off then.

DEVICE FOR STOPPING ALL WORKS WHEN ABNORMAL LOAD IS APPLIED

This function is provided to stop the primary belt conveyor, the optional work equipment (debris discharging conveyor (A) and magnetic selector (B), grizzly feeder and crusher automatically, when abnormal load (e.g. crushed object caught in the belt conveyor) is applied to the primary belt conveyor or the optional work equipment.

A horn begins to sound and it continues for five seconds after they come to a halt. Stop the engine then, remove the cause for the abnormal load like a stone caught in the belt conveyor and start the work again.

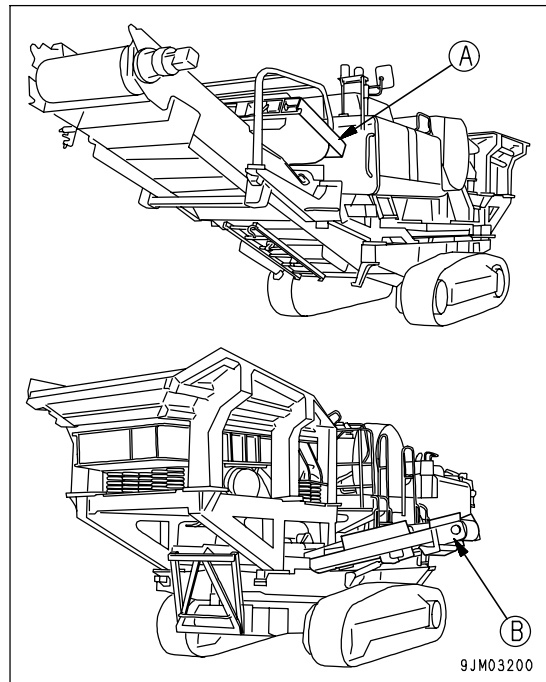

MONITOR WARNING DEVICE (REVOLVING WARNING LAMP LIGHTS UP)

When something unusual occurs in the engine coolant temperature, engine hydraulic oil pressure, battery charging amount, etc., each corresponding monitor lamp on the monitor panel lights up and the revolving warning lamp repeats coming on and off.

For further details, refer to the section "REVOLVING WARNING LAMP (PAGE 3-29)".

ERROR CODE DISPLAY DEVICE

When some failure or abnormality takes place on the machine, this function denotes the cause with a code number consisting of two alphanumeric letters.

This code number is shown on the LX controller display inside the main control box.

The LX controller display describes divers machine conditions in sequence. For details on the display sequence and contents of the error codes, see the section of "FAILURE DISPLAY BY LX CONTROLLER (PAGE 3-121)".

All the conceivable causes for the stop of the work equipment and respective corrective actions are shown in the table below.

Error code reference table

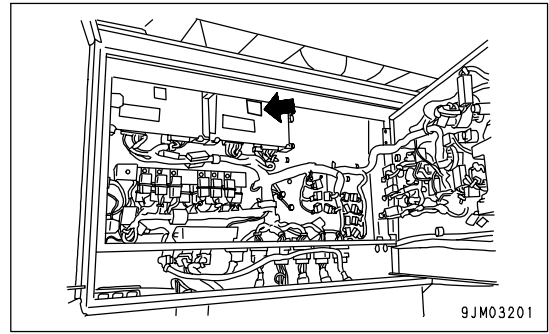

Contents of Error	Error Code	Major Cause	Corrective Action
Abnormality occurred on primary belt conveyor	00	Abnormal load is generated on the primary belt conveyor connecting line. Check that some foreign object is stuck or caught in the rollers or frame of the primary conveyor belt.	Remove excessive load causing the abnormality.
Abnormality occurred on debris discharging belt conveyor	02	Abnormal load is applied to debris discharging conveyor connecting line. Check that no foreign object is stuck or caught in the rollers or frame of the conveyor.	Remove excessive load causing the abnormality.
Abnormality occurred on magnetic selector	03	Abnormal load is applied to the magnetic selector connecting line. Check that no foreign object is stuck or caught in the rollers or frame of the magnetic selector.	Remove excessive load causing the abnormality.
Abnormality occurred on crusher	05	Abnormal load is applied to the crusher connecting line. Check that no foreign object is stuck or caught in the crusher chamber.	Remove excessive load causing the abnormality.
Abnormality occurred in engine oil pressure	07	Engine lubricating oil pressure lowers the normal level.	Stop the engine and check the engine lubrication system, such as oil level in the oil pan, etc.
Abnormality occurred in battery charging level	08	Battery is being charged abnormally.	stop the engine and check the battery terminals, cable, alternator, V-belt, etc.
Abnormality occurred in engine water temperature	0d	Engine water temperature exceeds 105°C.	Stop the work temporarily and idle the engine at low speed until the engine water temperature gauge points to the green zone.

Should any error code other than those listed above be displayed on the screen, consult the Komatsu distributor in your territory.

WATER SPRINKLER

- The sprinkler may be put in service only by connecting a hose between a tap water faucet and the coupling (1) of the machine. (Hose inner diameter: 14 mm (0.6 in))

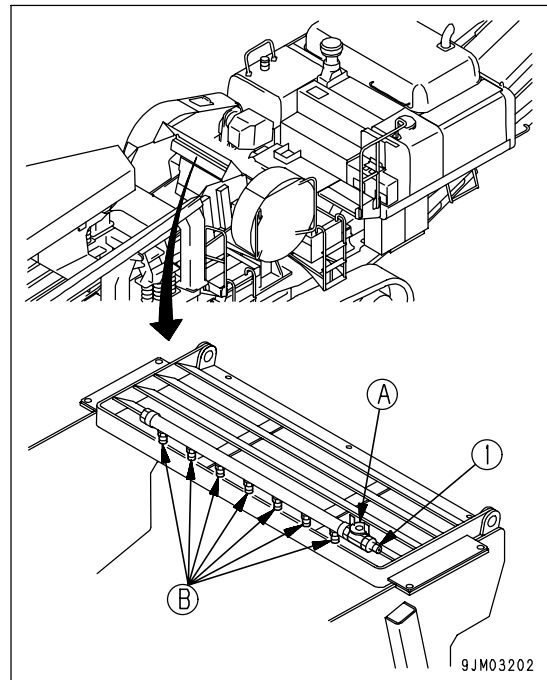

OPENING-CLOSING TYPE HOPPER

APPLICATION

This practice is intended to keep the overall machine height less than 3400 mm (11 ft 2 in) and the in-transport machine overall height less than 4000 mm (13 ft 1 in), and effective at reducing labor hours required to overhaul large components and transport them separately.

PROCEDURES FOR OPERATING OPENING-CLOSING TYPE HOPPER



WARNING

Keep well clear of the hopper and do not enter the operation radius of the hopper, while opening and closing it.

If it becomes necessary to climb on the feeder for installing a hook, when removing the wedges, be sure to stop the engine first, attach a safety belt to the worker and then start the work.

NAME OF EACH PART AND COMPONENT

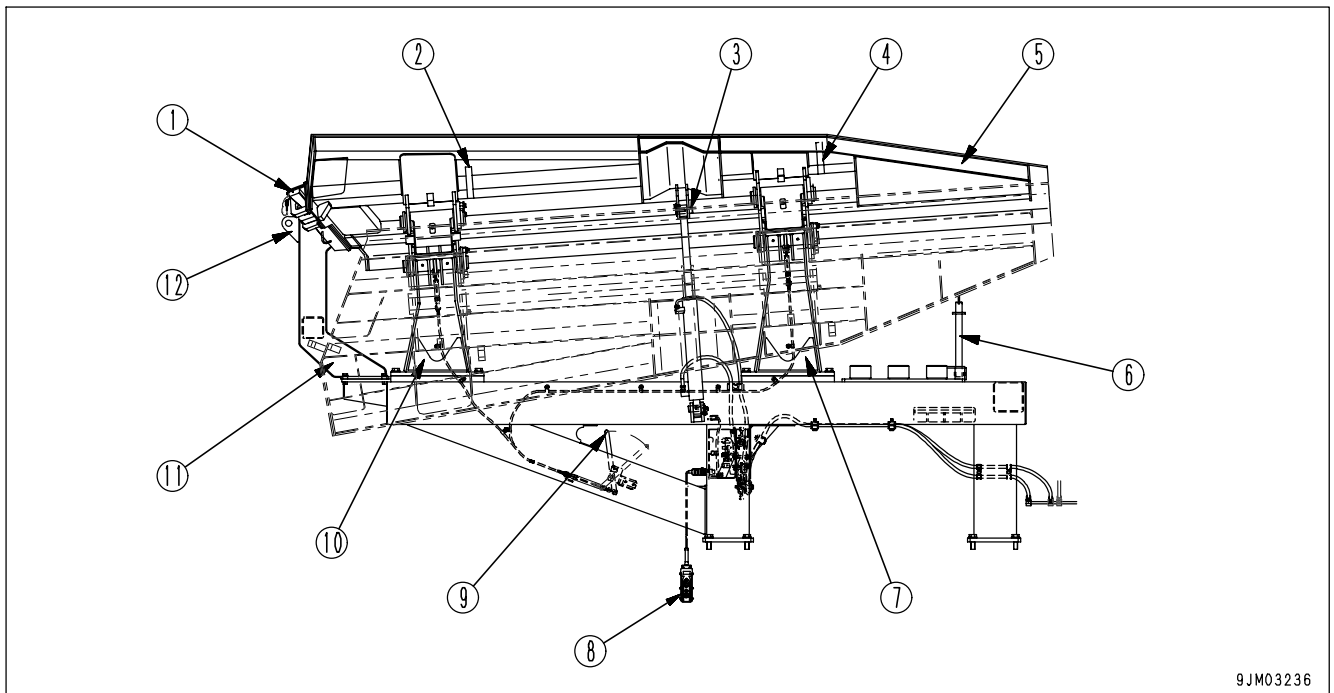

9JM03236

- | | |
|--|---|
| (1) Wedge (right and left corners) | (7) Hopper support (front) |
| (2) Lifting hook (side hopper) | (8) Hopper control switch box |
| (3) Hopper opening - closing cylinder (cylinder head side) | (9) Hopper locking lever (right and left) |
| (4) Lifting hook (side hopper) | (10) Hopper support (rear) |
| (5) Side hopper | (11) Rear hopper |
| (6) In-transport feeder securing pin | (12) Lifting hook (rear hopper) |

UNIT OPERATOR'S POSITION AT WORKSITE

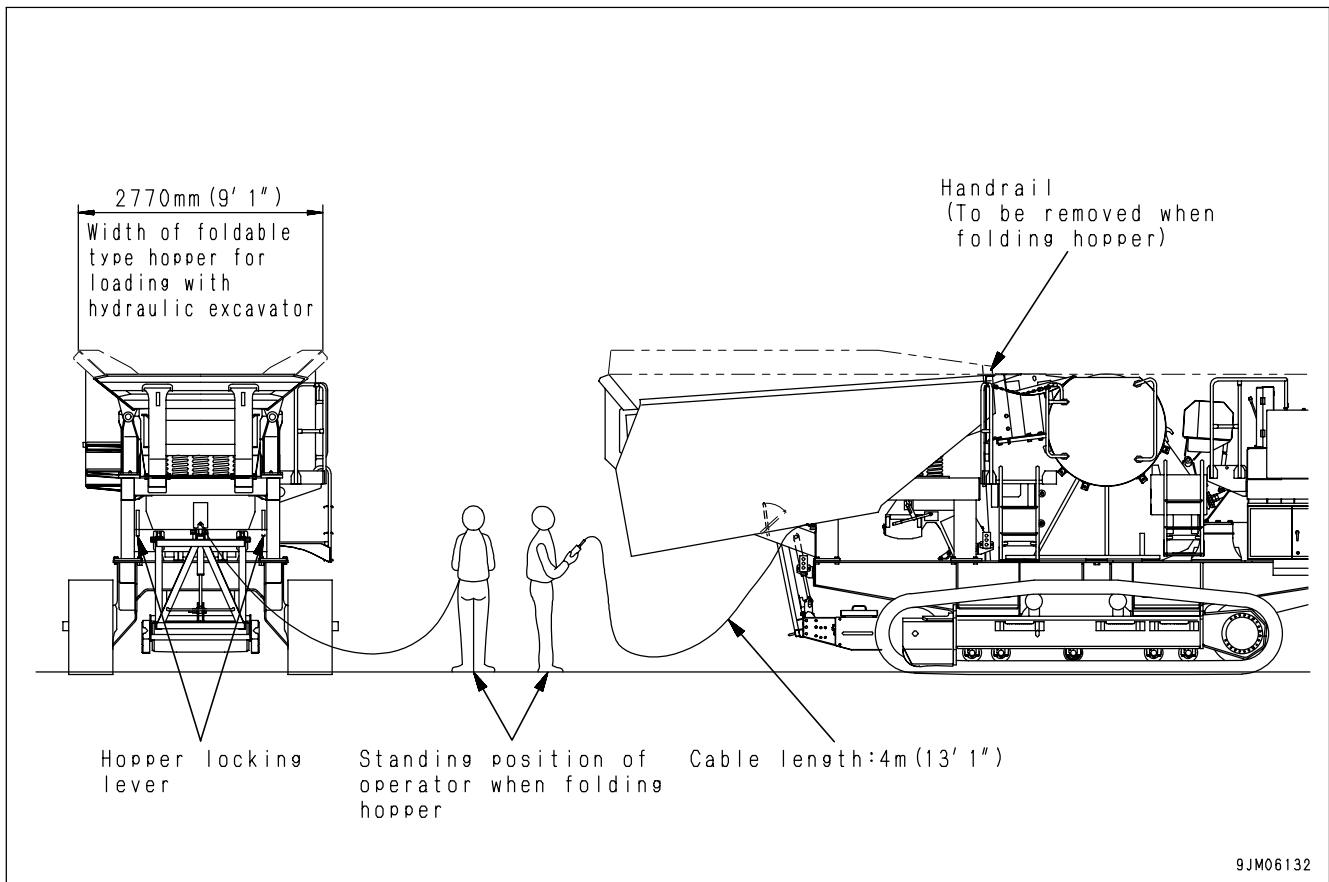

CHANGE OF MACHINE FROM OPERATION POSTURE TO TRANSPORTATION POSTURE

1. When transporting the feeder, insert securing pins into the two holes on the right and left sides at the front, and tighten the stopper bolts and washers.
2. Remove the wedges at the right and left corners of the hopper. [Wedge AGL height: 3.4 m (11 ft 2 in)]
Working mode:
(1) Use a ladder or scaffold.
(2) Drive out the wedges using a pipe and hammer. (A guide for the pipe is in place)
3. Remove a handrail on the right side of the machine.
4. Take out a hopper control switch box from the tool box and insert it into a connector at the center of the hopper underside. [Cable length: 4 m (13 ft 1 in)]
5. Start the engine and run it at low idling.
6. Depress right UP switch (1) to extend the cylinder rod and set the upper pin free.
7. Push the right hopper locking lever to the release position (toward the crusher) to fix the lever with a pin.
8. Depress right DOWN switch (2) to retract the cylinder rod and to fold the side hopper.
9. Pull the right hopper locking lever to the fixation position (toward the rear of the machine) to secure the lever with a pin.
10. Carry out the same works for the opposite side, using left UP switch (3) and left DOWN switch (4).
11. Stop the engine.
12. Detach the hopper control box from the connector and store it in the tool box.

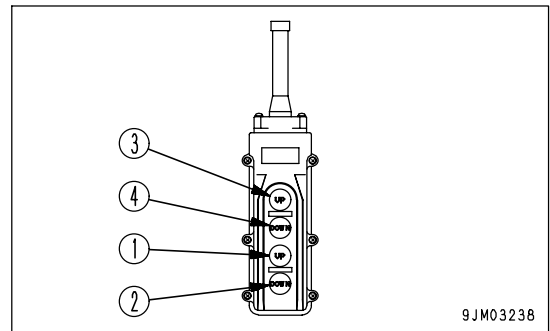

CHANGE OF MACHINE FROM TRANSPORTATION POSTURE TO OPERATION POSTURE

1. Confirm that both right and left hopper locking levers are pulled to the fixation position.
2. Take out a hopper control switch box from the tool box and insert it into the connector at the center of the machine underside. [Cable length: 4 m (13 ft 1 in)]
3. Start the engine and run it at low idling.
4. Depress right UP switch (1) to extend the cylinder rod, thereby raising the side hopper, and then confirm that the tip of the upper pin is on the seat.
5. Depress right DOWN switch (2) to retract the cylinder rod and let the tip of the upper pin contact the seat closely.
6. Carry out the same works for the opposite side, using left UP switch (3) and left DOWN switch (4).
7. Stop the engine.
8. Insert a wedge at the right and the left corners of the hopper. [AGL height of wedges: 3.4 m (11 ft 2 in)]
Working mode
(1) Use a ladder or scaffold.
(2) Climb on the feeder to carry out the work.
9. Remove the feeder in-transport securing pins.
10. Detach the hopper control box from the connector and store it in the tool box.

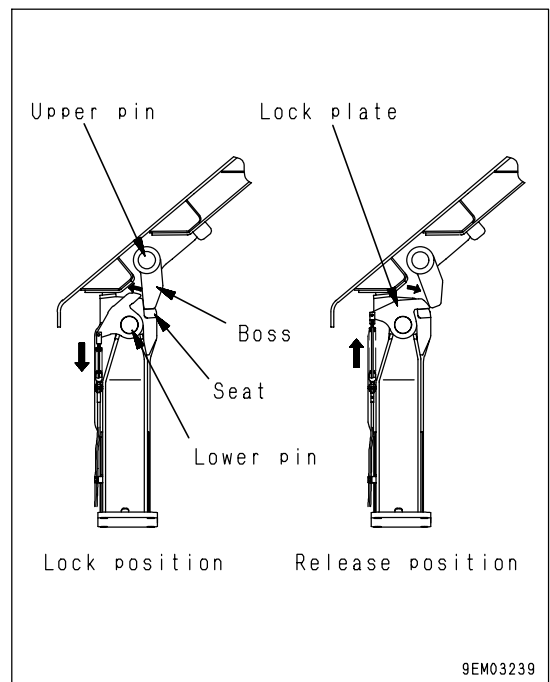

PROCEDURES FOR DISASSEMBLING OPENING-CLOSING TYPE HOPPER



WARNING

If it becomes necessary to climb on the feeder to install a hook, when removing the wedges, be sure to stop the engine, attach a safety belt to the worker and then start the work.

In case transport regulations necessitate to disassemble the hopper, carry out the disassembly and subsequent reassembly works in the following manner.

DETACHING SIDE HOPPER

Remove the wedges at the right and left corners of the hopper. [AGL height of wedge: 3.4 m (11 ft 2 in)]

Working mode

- (1) Use a ladder or scaffold.
- (2) Drive out the wedges with a hammer and pipe, standing on the ground. (A guide for the pipe is in place on the hopper)

Pull out the cylinder head pin of the hopper opening-closing cylinder. [AGL of cylinder head: 3.4 m (11 ft 2 in)]

Working mode

- (1) Use a ladder or scaffold.
- (2) Climb on the feeder and carry out the work.

Insert two eyebolts (M20 x 2) into the inside of the side hopper and set a lifting hook to the eyebolts. (Side hopper weight: 754 kg (1663 lb)/piece)

Pull out the pins at the lower position of the hopper support (at two points on one side) to completely detach the hopper, while lifting it up.

(Store the removed pins in the tool box)

DETACHING REAR HOPPER

1. Insert two eyebolts (M20 x 2) into the inside of the rear hopper and set a lifting hook to the eyebolts. [AGL height of loop: 3.2 m (10 ft 6 in)]
2. Remove securing bolts (M24 x 4 bolts).
(In case shim plates are used, remove them only after keeping a record of the location and the number)
3. Lift up the rear hopper. [Rear hopper weight: 344 kg (759 lb)]

DETACHING FRONT AND REAR HOPPER SUPPORTS

1. Detach a clamp for the wire of the hopper locking lever that is fitted inside the hopper support.
(Fasten the detached wire and locking plate to the hopper frame, using a rubber band)
2. Pass a lifting wire rope through the pin hole ($\phi 71.5$) at the lower position of the hopper support. [AGL height of pin hole: Front 3.1 m (10 ft 2 in) and rear 2.9 m (9 ft 6 in)]
3. Remove securing bolts (M24 x 4 bolts).
(In case shim plates are used, remove them only after keeping a record of the location and the number)
4. Lift up the hopper supports.
[Hopper support weight: Front 111 kg (245 lb) /piece and rear 99 kg (218 lb) /piece]

LOCKING FEEDER

1. Pass the feeder in-transport securing pins through the holes at the front right and left spring seats, and tighten the stopper bolts and washers.

PROCEDURES FOR REASSEMBLING OPENING-CLOSING TYPE HOPPER

Reassemble the hopper in the reverse order of disassembly.

REPRESENTATIVE DIMENSIONS AND WEIGHT OF MAJOR COMPONENT PARTS

- Side hoppers (right and left 754 kg (1663 lb)/piece)

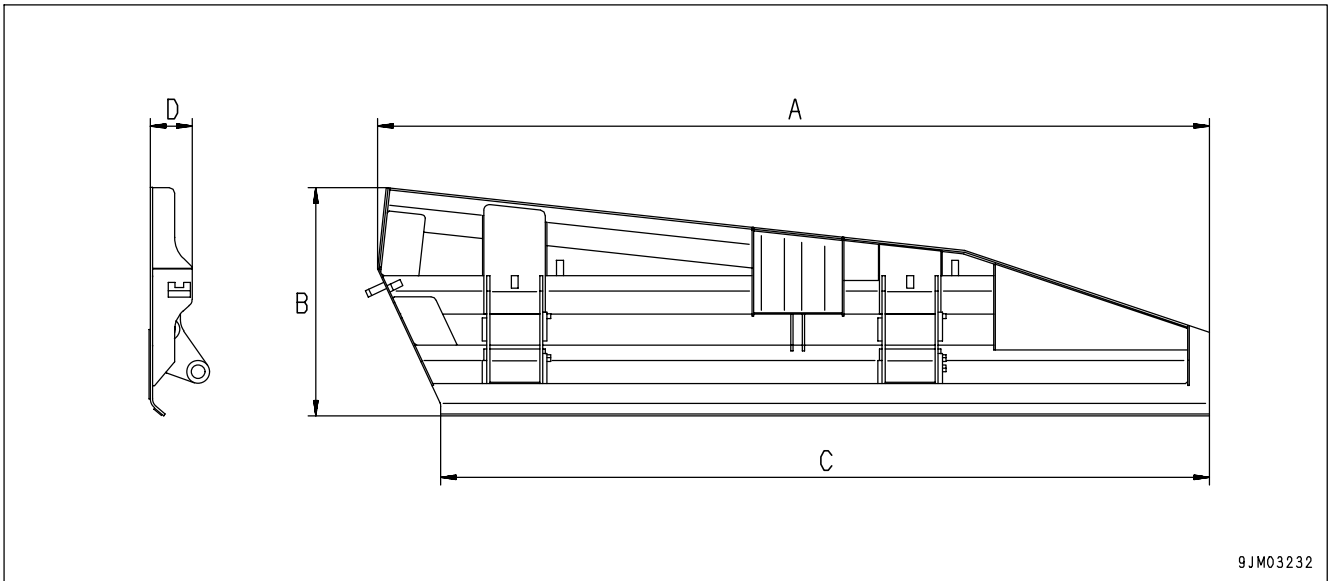

9JM03232

Dimensions	Unit [mm (ft in)]
A	4325 (14' 2")
B	1185 (3' 11")
C	3995 (13' 1")
D	215 (0' 8")

- Rear hopper [weight: 344 kg (759 lb)]

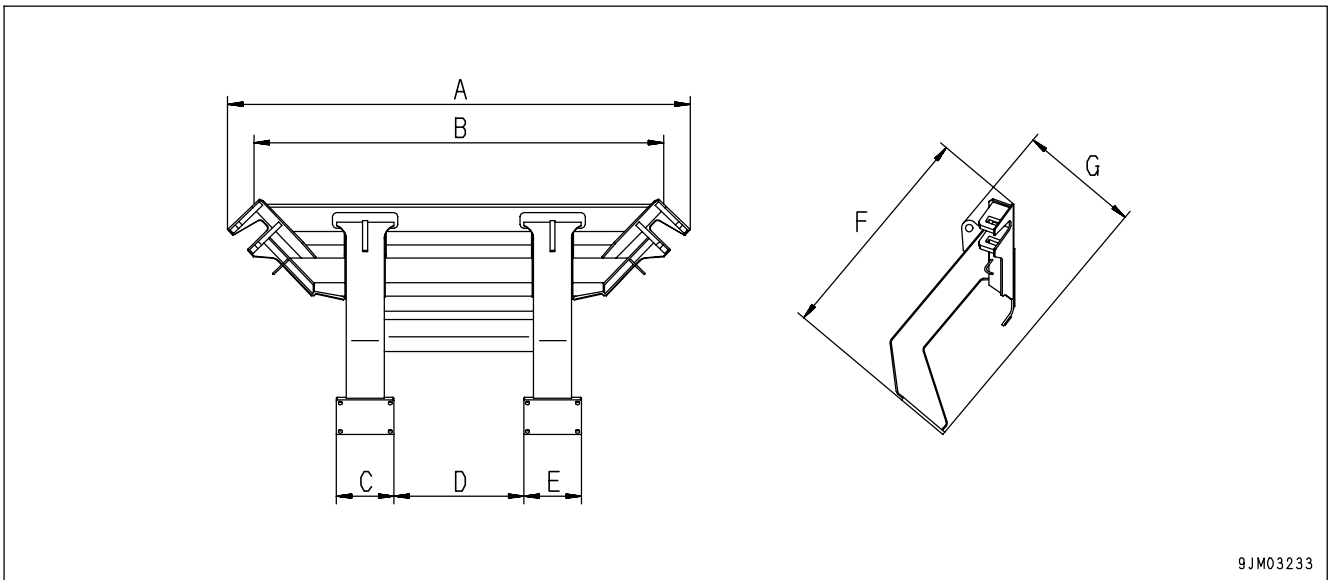

9JM03233

Dimensions	Unit [mm (ft in)]
A	2405 (7' 11")
B	2130 (6' 12")
C	300 (0' 12")
D	675 (2' 3")
E	300 (0' 12")

Dimensions	Unit [mm (ft in)]
F	1155 (3' 9")
G	625 (2' 1")

- Hopper support [front 222 kg (49 lb) in 2 pieces]

Dimensions	Unit [mm (ft in)]
A	250 (0' 10")
B	545 (1' 9")
C	940 (3' 1")
D	250 (0' 10")
E	240 (0' 9")

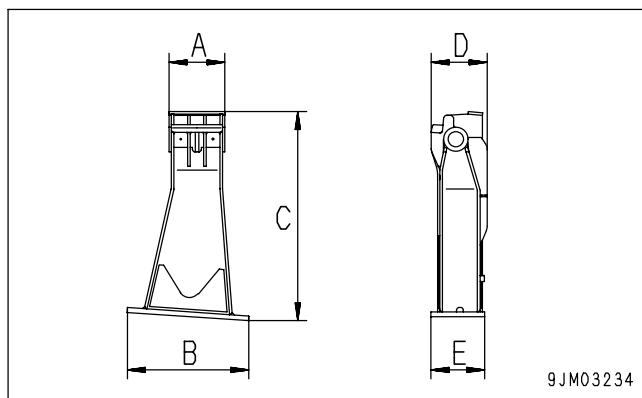

- Hopper support [rear and weight 198 kg (437 lb) in 2 pieces]

Dimensions	Unit [mm (ft in)]
A	250 (0' 10")
B	545 (1' 9")
C	940 (3' 1")
D	250 (0' 10")
E	240 (0' 9")

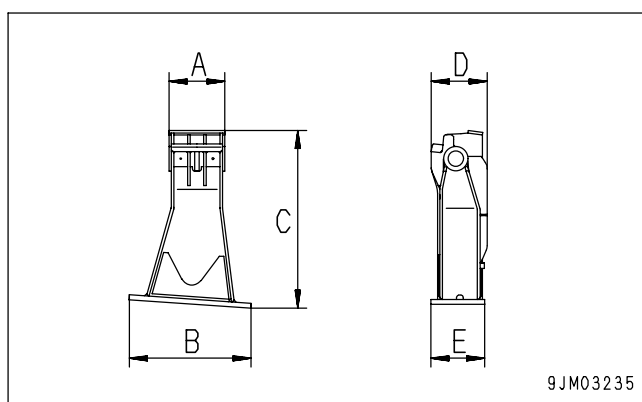

WORK POSTURE AND TRANSPORTATION POSTURE OF MACHINE SPECIFICATIONS

Hopper when closed: Working posture

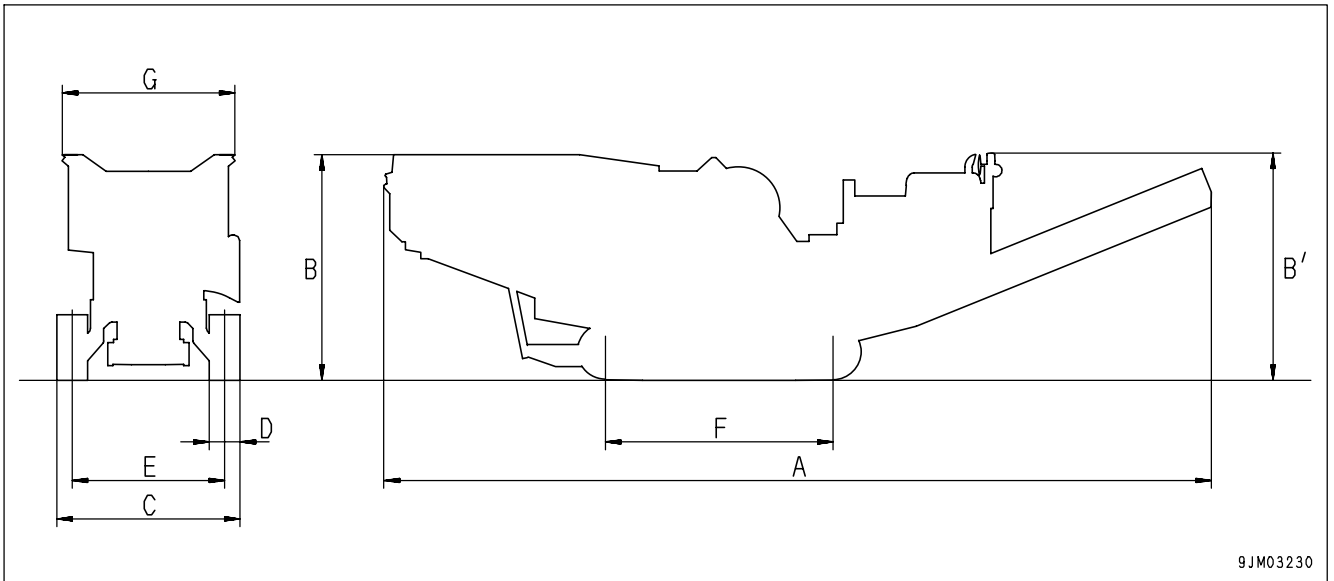

9JM03230

Dimensions	Unit [mm (ft in)]
A	13475 (44' 3")
B	3640 (11' 11")
B'	3660 (12' 0")
C	3115 (10' 3") [2980 (9' 9")]
D	500 (1' 8")
E	2480 (8' 2")
F	3700 (12' 2")
G	2770 (9' 1") (Hydraulic excavator for loading) 3720 (12' 2") (Wheel loader for loading - optional)

Hopper when folded: In-transport posture

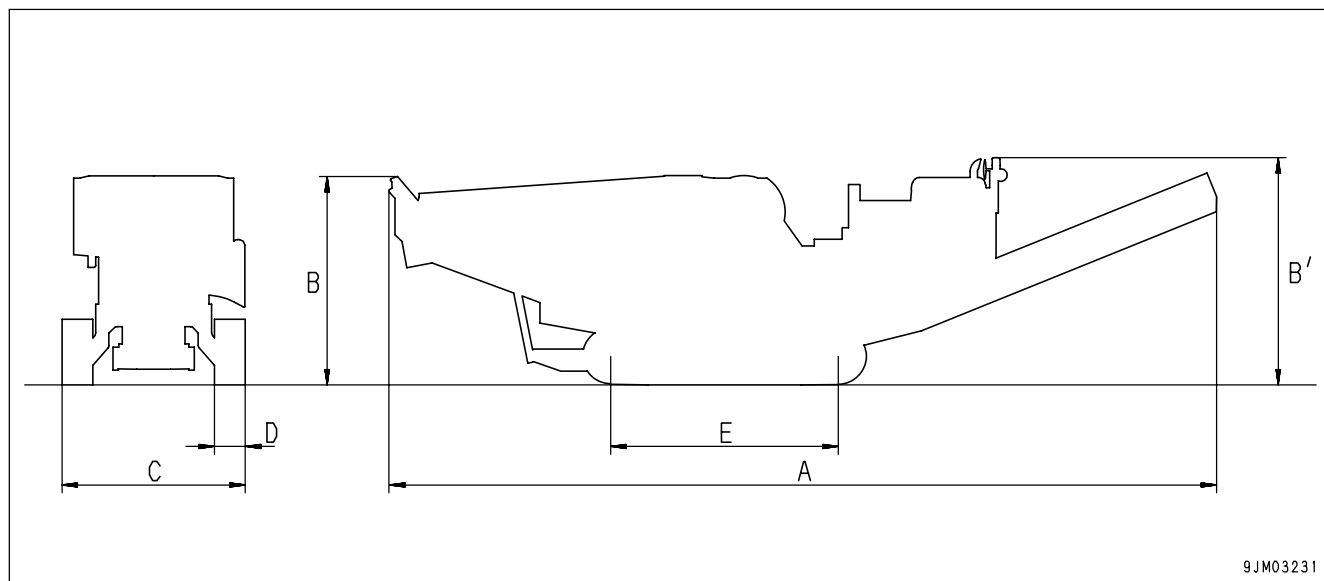

Dimensions	Unit [mm (ft in)]
A	13475 (44' 3")
B	3395 (11' 2")
B'	3690 (12' 1")
C	2980 (9' 9")
D	500 (1' 8")
E	3700 (12' 0")

SPECIFICATIONS

Item	Unit	Foldable (open-close) type hopper
Hopper		
Capacity	m ³ (cu.yd)	6.0 (7.8)
Weight	kg (lb)	Approx.2300 (5072)

CHECK AND CONFIRMATION OF JAW CRUSHER AFTER WORK

1. After confirming that no more fresh debris is fed on to the grizzly feeder, depress grizzly feeder stop switch (1) to stop the grizzly feeder.
2. After confirming subsequently that there are no debris and stones left inside the jaw crusher, depress jaw crusher stop switch (2) to stop the jaw crusher.
3. After confirming that the jaw crusher has completely stopped and that there are no more crushed materials to be discharged with the belt conveyor, depress primary belt conveyor stop switch (3) to stop the conveyor.

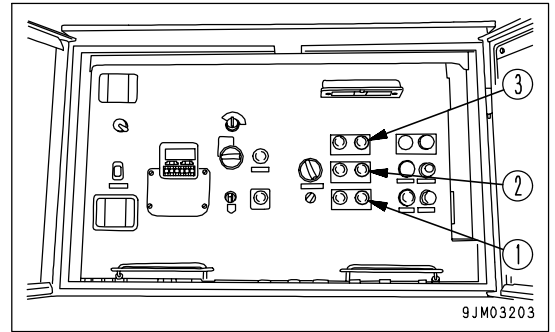

CHECK AFTER FINISHING WORK

For normal stop of the engine, see the section of "STOPPING ENGINE (PAGE 3-54)".

LOCKING

Always lock the following places.

- (1) Fuel tank filler port
- (2) Engine hood
- (3) Battery box cover
- (4) Machine left side door
- (5) Machine right side door
- (6) Tool box
- (7) Main control box
- (8) Hydraulic oil tank filler port

REMARK

Use the starting switch key to lock and unlock all these places.

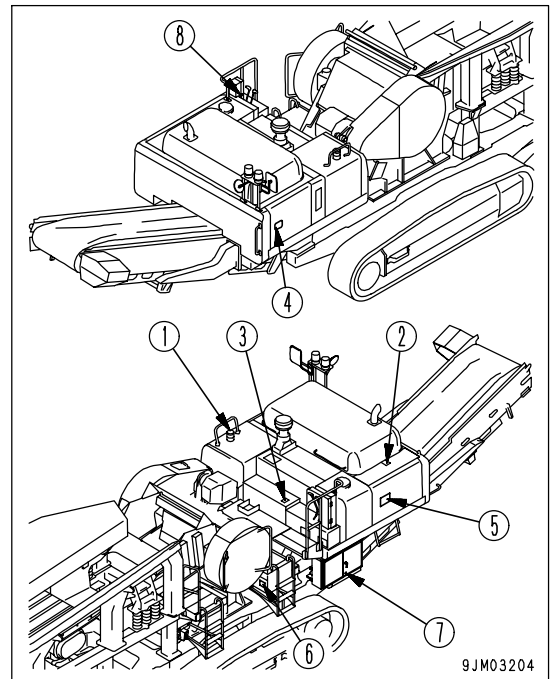

RUN-IN OPERATION OF JAW CRUSHER

After confirming by inspection that there is nothing unusual with the jaw crusher, carry out both no load operation and loaded operation by way of running-in in the following manner, but this should be conducted only at the time of the initial delivery.

NO-LOAD OPERATION FOR MORE THAN 3 HOURS

NOTICE

Carry out a running-in also when replacing a crusher wearing parts or reversing a jaw plate. If load is increased fast, partial friction may be caused to various inner parts, leading to their shortened service life.

Check if the bearings have generated abnormal heat.

LOADER OPERATION

Start to feed fresh debris to the jaw crusher after confirming that the crusher revolution stays steady and constant. If the debris are found directly hitting the swing jaw protector, after starting the feeding, try to change the feeding mode so that they will not hit the protector.

The feeding amount at a time should not be up to the full capacity, but follow the values shown in the table below.

Loaded operation (after no-load operation)

Load Ratio (Charging Amount) %	No. of Days
30	Two days
60	Two days
60 - (100)	After the days above

FEEDING AMOUNT OF DEBRIS AS RAW MATERIAL

Continue with the ordinary operation after the running-in, keeping the debris feeding amount less than 60% of the crusher chamber capacity.

STOP OF WORKS

After terminating to feed fresh debris, stop the motor, confirming that crushing work has been completed finished.

RETIGHTENING OF BOLTS AFTER WORKS

Each part securing bolt is likely to loosen at the initial stage of machine operation. Check and tighten the part securing bolts based on the following table, after the loaded operation is commenced.

The 1st time	The 2nd time	The 3rd time	Thereafter
After 4 hours	After 8 hours	After 50 hours	Every 100 hours

Tightening torque for bolts used in jaw crusher Unit: N-m (kgf-m, lbft)

Bolt Size	Target Value	Tolerance	Major Applicable Points
M10	65.7 (6.7, 48.5)	58.8 to 73.5 (6.0 to 7.5, 43.4 to 54.2)	
M12	112.8 (11.5, 83.2)	98.1 to 112.6 (10.0 to 12.5, 72.3 to 90.4)	
M16	279.5 (28.5, 206.1)	245.2 to 308.9 (25.0 to 31.5, 180.8 to 227.8)	Toggle seat holding BKT
M20	549.2 (56.0, 405.6)	490.3 to 608.0 (50.0 to 62.0, 361.7 to 448.4)	Protector securing bolt, toggle block holding BKT
M24	926.7 (94.5, 683.5)	823.8 to 1029.7 (84.0 to 105.0, 607.6 to 759.5)	Cheek plate securing bolt (fixed jaw plate & swing jaw plate wedge bolts)
(M30)	1716.2 (175.0, 1265.8)	1520.0 to 1912.3 (155.0 to 195.0, 1121.1 to 1410.4)	(Slotted head nut of tension spring rod)
M36	2745.9 (280.0, 2025.2)	2451.7 to 3040.1 (250.0 to 310.0, 1808.3 to 2242.2)	Crusher securing anchor bolt
M42	5325.0 (543.0, 3927.5)	4256.1 to 6393.9 (434.0 to 652.0, 3139.1 to 4715.9)	Tension spring rod tip (spring side of tension spring rod)
M64	6825.4 (696.0, 5034.2)	5462.3 to 8188.6 (557.0 to 835.0, 4028.8 to 6039.8)	Bearing cap bolt

BACK LASH ON FIXED JAW PLATE

An amount of backlash at the fixed jaw plate may increase at the initial stage of machine operation or right after replacement or reversal of the fixed jaw plate (within 30 hours). This is largely due to deformation of the fixed jaw plate at the securing portion. If this happens, check again if the spring set length of the wedge bolts securing the fixed jaw plate is within the specified limit. If not, tighten the wedge bolts again.

If backlash at the fixed jaw plate cannot be corrected, detach the plate, then completely remove dirt and sand stuck to the backside of the plate and the frame and install it again.

CONFIRMATION OF BEAR-LOC CYLINDER LOCKING FORCE

Check of locking force after operation



CAUTION

- After adjusting the clearance at the outlet of the crusher jaw, be sure to carry out a trial operation under the trial conditions of engine revolution at low idling and crusher revolution at MIN and confirm that there is no abnormal noise from around the toggle block.
- When inserting shim plates, confirm the total number and thickness of the right and left shims to ensure the identical shim plate thickness on both sides.
Should the shim plate thickness differ between the right and the left sides, there would be a critical damage to the crusher main body.

For some time after an operation is started with load, the locking force may be reduced on account of insufficient contact of the shims or fine foreign objects caught between the shims. When adjustment was made of the clearance at the outlet of the crusher due to the wear on the swing jaw plate and fixed jaw plate, tighten the shim plates (toggle block) every 30 minutes of operation until no backlash is confirmed.

Checking method

Hit the shim plates and the toggle block pins with a hammer to see if there is any backlash.

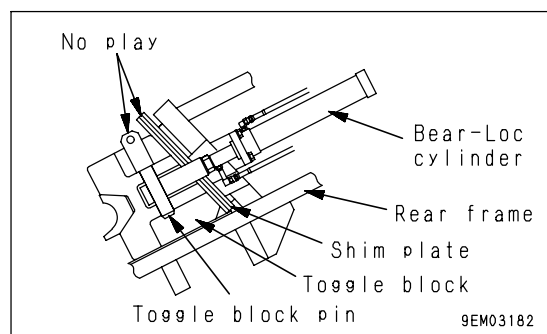

REMARK

If the backlash can be settled by no means, remove all the shims once by pushing the toggle block to the extreme front end, following the same procedure for the jaw crusher outlet clearance adjustment, and then blow them with an air or water gun to remove foreign objects.

PRECAUTIONS WHEN OPERATING JAW CRUSHER

1. Be sure to operate the machine with the V belt cover and the flywheel cover installed properly.
2. Start the jaw crusher without any debris left in the crusher chamber.
3. Feed fresh debris to the trough, avoiding directly hitting the bars, of the grizzly feeder.
4. In a continuous work, keep the debris feeding amount less than 50% of the hopper capacity.
Avoid charging the hopper fully, since not only the work efficiency is lowered, but also debris may clog the inlet, causing a failure.
5. Do not try to look into the crushing chamber while in operation. That is very dangerous, because crushed debris may fly off and hit you.
6. To stop the jaw crusher, stop feeding debris first, next check that there is nothing to be crushed any more in the crusher chamber and then stop it.
7. Do not blast debris in the crusher chamber.
8. If it becomes necessary to hang a parts at the time of replacing wear parts, do not go under the hung parts.
9. Retighten each bolt sufficiently.

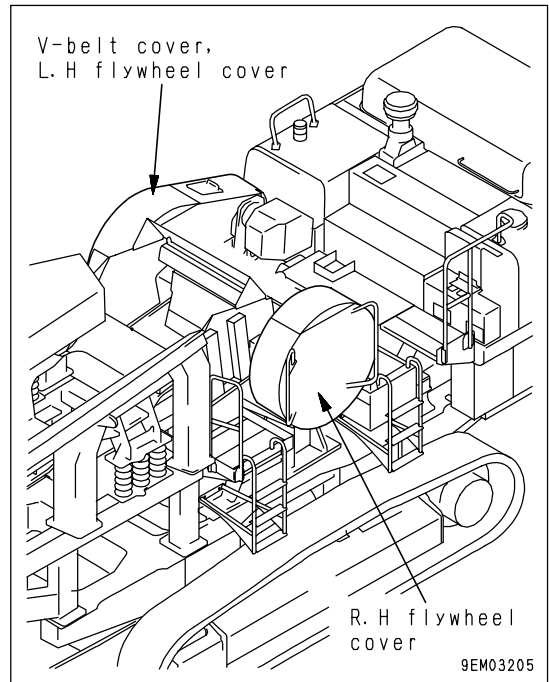

10. Use shim plates of the same dimensions on the right and left sides of the jaw crusher.
11. When adjusting the clearance at the outlet of the crusher, do so only after the crusher has been completely stopped. For details, see "CHECK AND ADJUSTMENT OF OUTLET CLEARANCE (PAGE 4-36)".
12. When replacing the toggle plate, lift it temporarily with a wire rope and start the replacement work.
13. Do not feed a reinforcing bar exceeding 600 mm (23.6 in) in length and 13 mm (0.5 in) in diameter, because it can cause a trouble to the jaw crusher and the primary conveyor.

14. If the teeth of the swing jaw plate and the fixed jaw plate are worn out beyond the specified limit, either reverse or replace the jaw plate.

-> If used beyond the specified limit, the worn jaw plate will cause a serious damage to the jaw crusher main body.

15. Procedure and caution for removing foreign objects inside crusher

Should foreign objects such as iron lumps and wooden blocks other than crushable materials (rock and concrete block) have been fed, mixed with debris, and clogged the jaw crusher, remove them following the instructions given below.

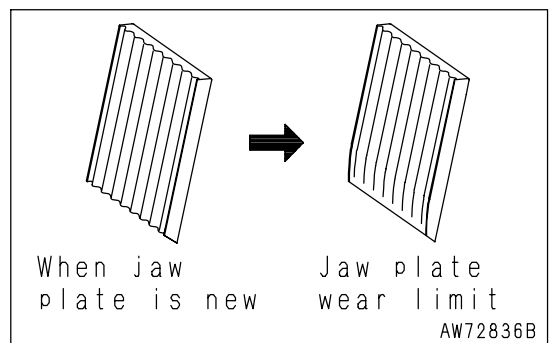

 **WARNING**

- When you have to get in the crusher chamber for works like repair or maintenance, turn off the engine, pull out the engine starting switch key, and then start the work.
- Be sure to attach a caution tag to the starting switch for the main control box.

Removing foreign objects by inching operation

1. Set the engine starting switch to the OFF position, then remove all crushed debris piled on the foreign object.
2. Start the engine again.
3. Turn fuel control dial (1) to the MAX position.
4. Start an inching operation, using jaw crusher inching switch (reverse rotation) (3).

If the clearance among the foreign object, the swing jaw plate and the fixed jaw plate, or its posture is judged as not proper, make another inching operation, using jaw crusher inching switch (normal rotation) (2) this time.

5. If a sufficient clearance is created among the foreign object, the swing jaw plate and the fixed jaw plate, put the engine starting switch key to the OFF position, then pull out the key, and begin the work of lifting up the foreign materials.

In case a foreign object cannot be removed by inching operation;

1. Set the engine starting switch key to the OFF position and pull out the key.
2. If the foreign object is an iron or steel lump, gas-cut it to pieces.
3. If the work inside the crusher chamber is found difficult, cut the toggle plate off with a gas flame.

When the work in Item 3 is required, carry out the work, referring to the section, "Work procedures: Replacement of toggle plate".

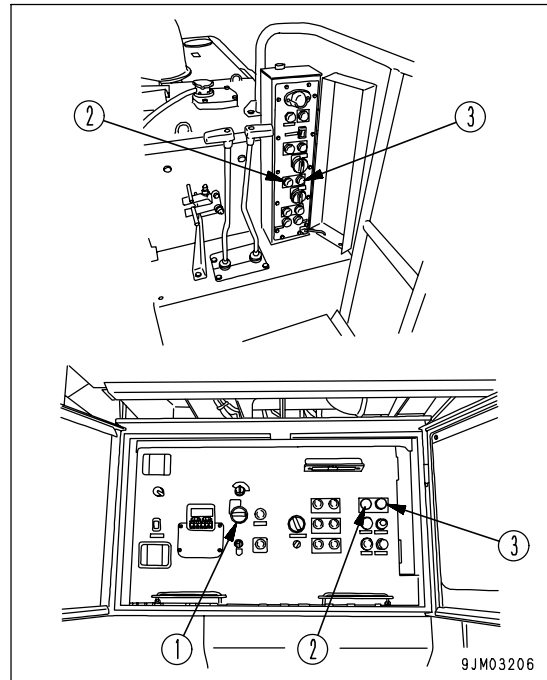

EFFICIENT USE OF JAW CRUSHER

PRINCIPLE OF CRUSHER OPERATION

The swing jaw makes a circular motion at contact point (1), but it makes a long and thin elliptical motion at points closer to contact point (3) owing to the eccentric crankshaft and a swing motion of the toggle plate.

The swing jaw plate fixed to the swing jaw repeats the above mentioned motion against the fixed jaw plate. Hence the debris fed into the crusher chamber are subjected to the more compression force, as they go down, and eventually crushed.

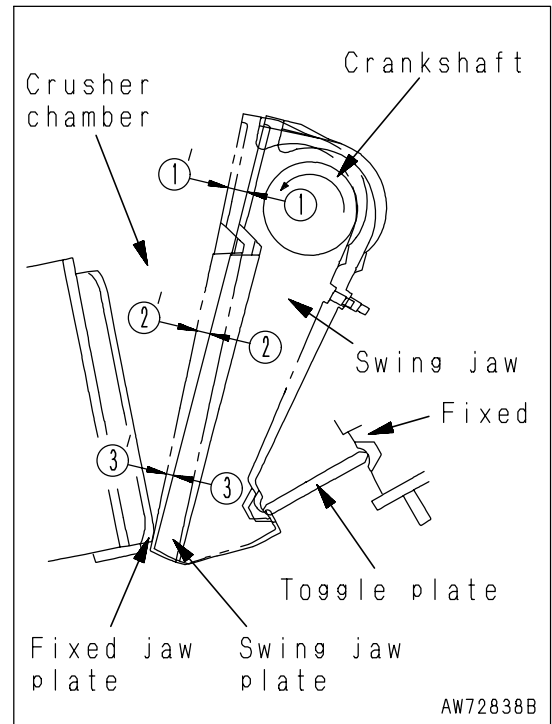

The toggle plate has such a function that, when some uncrushable material like an iron lump is fed into the crusher chamber, it deforms itself to shield the shafts and the bearings from a large impact load.

The clearance between the fixed jaw plate and the swing jaw plate can be adjusted by changing a combination of set shims to change the size of crushed debris.

Both fixed jaw plate and swing jaw plate are reversible, so when worn out, use them for once by turning them vertically.

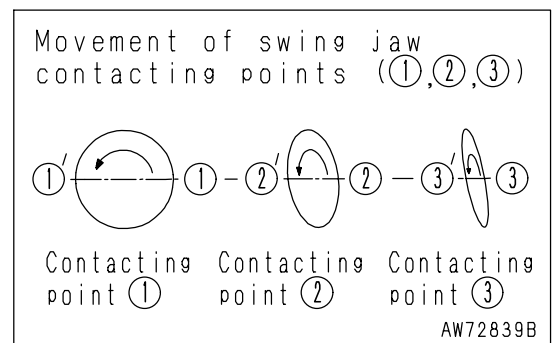

Service life of the fixed jaw plate and swing jaw plate can greatly change depending on debris and operating conditions. Generally it can be shortened when fed with debris containing a large amount of soils and water, and when the outlet clearance is narrowed.

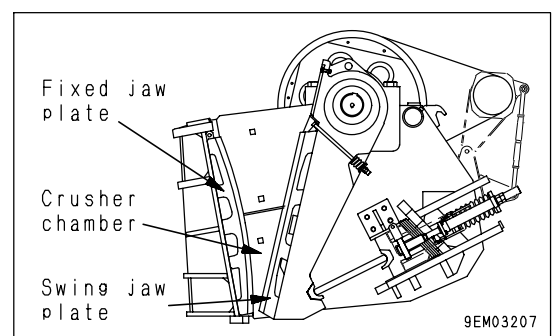

USAGE OF JAW CRUSHER

GRAIN DISTRIBUTION, ADJUSTMENT OF CRUSHER OUTLET CLEARANCE AND CRUSHABLE AMOUNT

DEFINITION OF "UNDER 40"

The grain size of 0 to 40 mm (0 to 1.6 in) shown in the catalog indicates a grain size distribution in which the maximum size of the crushed concrete block is 50 mm (2.0 in) in diameter and concrete blocks smaller than 40 mm (1.6 in) account for approx. 95% of all.

ADJUSTMENT OF CRUSHER OUTLET CLEARANCE

The clearance value is the maximum width of the outlet. If this is adjusted to 55 mm (2.2 in), the grain size of crushed debris is less than 40 mm (1.6 in) on condition that debris to be crushed is a concrete block; both fixed jaw plate and swing jaw plate are brand new; the grizzly bar pitch is 50 mm (2.0 in).

Generally dimension in the grain size distribution can be defined as follows;

Dimension in grain size distribution = Outlet clearance - 10 mm (0.4 in)

GRAIN DISTRIBUTION

The jaw crusher outlet is so shaped as shown in the figure at right. The clearance can be adjusted in direction "a" (crusher amplitude stroke), but cannot be adjusted in direction "b" (crusher width) or vertically.

Accordingly the grain size of crushed debris such as concrete, which can be crushed to a cubic form like a dice, is 0 to 40 mm (0 to 1.6 in) in diameter with OSS set at 50, which covers nearly 95% of all. When natural rocks are crushed, meanwhile, they may be crushed flatly along their grains. As a result the ratio of blocks in the range of 0 to 40 mm (0 to 1.6 in) is reduced.

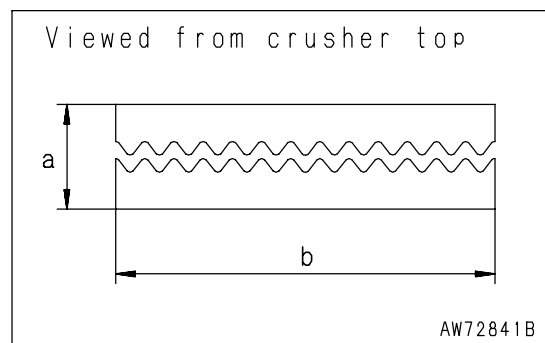

NOTICE

When crushed debris are heaped up, blocks of larger grain size are outstanding. This is because the larger a grain size is, the less specific gravity a block has and blocks of large grain size tend to surface. Usually there are more grains of small diameter than it appears.

When crushing natural stones, the minimum allowable outlet clearance is 100 mm (3.9 in). If set at less than 100 mm (3.9 in), it can cause a damage on the crusher main body and premature wear of the jaw plates.

CRUSHABLE AMOUNT

The crushable amount shown in the catalog is a value measured under the condition of the best adjustment. In order to gain the practical value in the ordinary crushing work, therefore, it is recommended to multiply the catalog value by work coefficient of 0.6 to 0.75.

DETECTING WEAR ON JAW PLATES

CAUSE FOR PREMATURE WEAR

	Advanced	Delayed
Outlet clearance	Narrow	Wide
Water content	Plenty	Scarce
Muck mixing ratio	Plenty	Scarce
Sio2 content in silica	Plenty	Scarce
Rock hardness	Hard	Soft

The outlet clearance and silica content particularly exercise a big influence among several factors listed above.

PREVENTION OF PREMATURE WEAR

An ideal way to deter wear on the fixed and swing jaw plates is not to narrow the outer clearance extremely but adjust it a bit wider than specified and use a sieve together.

Do not try to set the minimum clearance at the outlet of the jaw crusher below 55 mm (2.2 in) in case of handling concrete debris, and below 100 mm (3.9 in) in case of handling natural stones.

PRECAUTIONS WHEN OPERATING JAW CRUSHER

PRECAUTIONS IN OPERATION

1. Adjust the grizzly feeder so that the crusher chamber will not be filled more than 80% at the most (approx. 60% on average). Never fill up the crusher chamber.
If the feeding rate is too high, abnormal wear develops on the center to upper part of the fixed and swing crusher plates.
2. Try to feed a large chunk of debris or a concrete block containing many reinforcing bars toward the end of the day's operation, because they are highly likely to disrupt the work by stopping the machine.

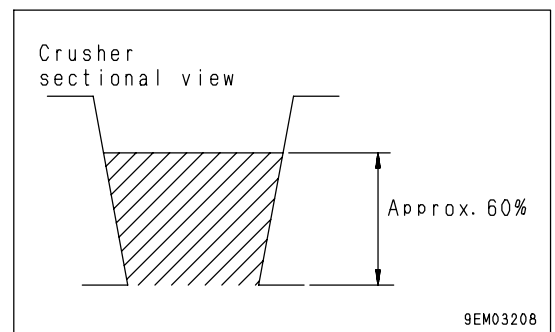

PREPARATION FOR DEBRIS AS RAW MATERIALS

1. Break debris into small pieces having a size below 1200 x 950 x 600 mm (47.3 x 37.4 x 23.6 in) in advance.
If there are a number of blocks having the maximum allowable dimensions in the debris to be crushed, crushing efficiency will be lowered. (Break natural stones into pieces having a size below 600 mm (23.6 in) cube).
2. Debris should not contain so much water that it becomes muddy.
3. Preferably reinforcing bars should not be included in the debris to be crushed for better working efficiency. (They tend to narrow the clearance at the outlet, thereby reducing the discharging efficiency)
4. For good work efficiency, debris may well be mixed in the debris to be crushed at the rate of 20 to 30%.
(If this ratio is higher than that, debris serves as a cushion in the crusher chamber, lowering the work efficiency. Moreover it causes premature wear on the fixed and swing jaw crusher plates)
5. Do not allow impurities (wood, paper, etc.) to get mixed in the debris to be crushed. Otherwise they can clog the outlet, and lowered debris discharge may lead to a damage on the crusher and toggle plate.

BASIC USAGE OF GRIZZLY FEEDER (EFFECTIVE METHOD FOR REMOVING MUCK)

Grizzly feeder is installed to separate soils and sand from rocks and concrete blocks. Pay attention to the conditions of the screen.

UNDESIRABLE USAGE

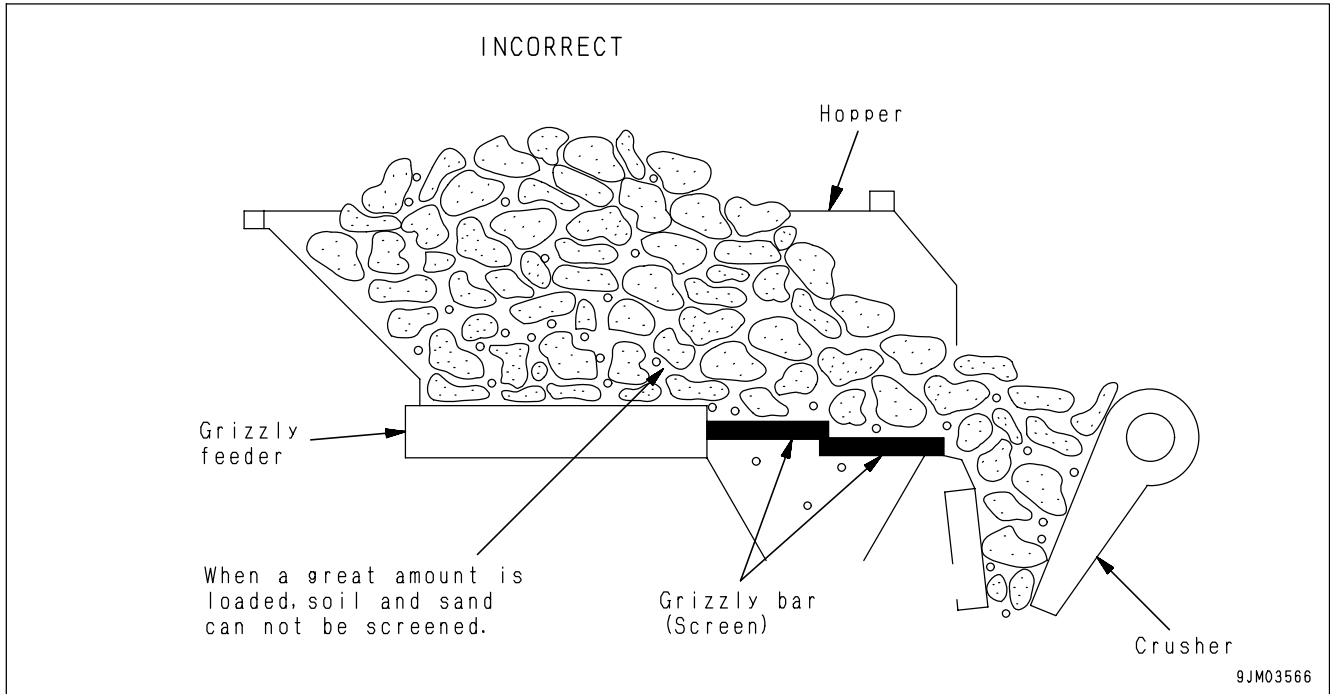

DESIRABLE USAGE

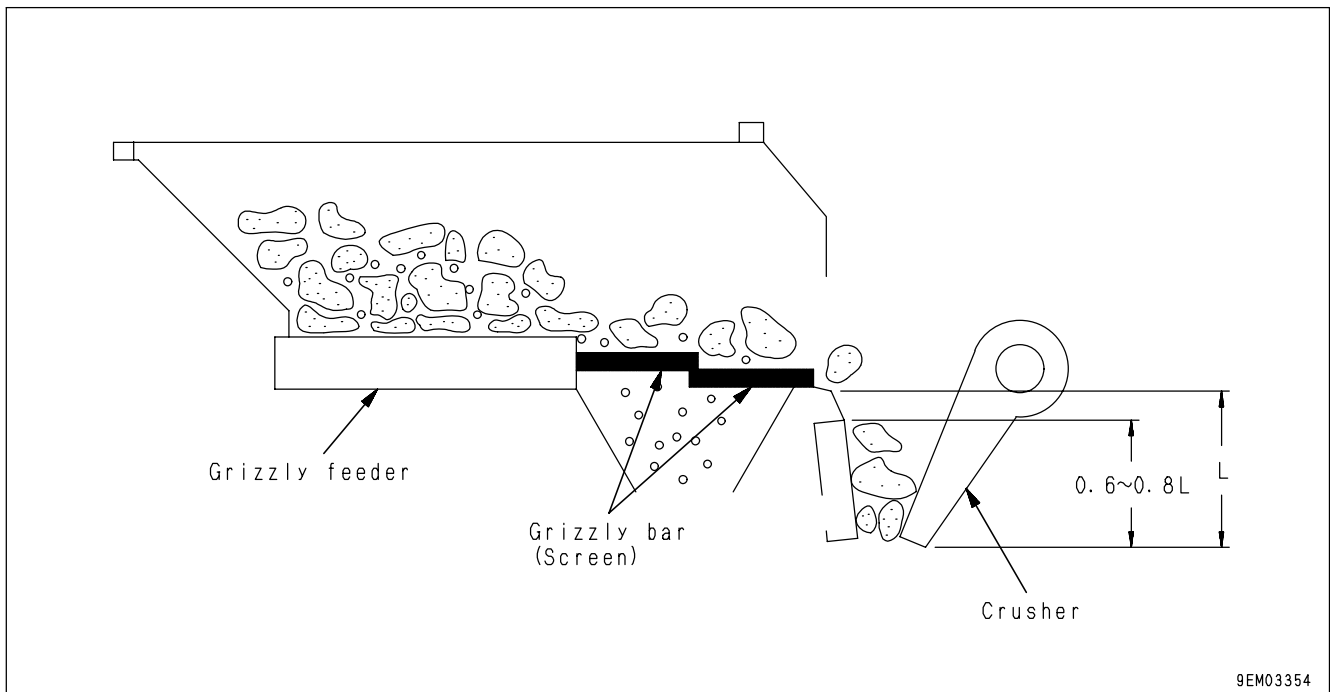

EXAMPLE FOR DESIRABLE OPERATION**STEP 1**

The optimum feeding quantity at a time is 0.7 to 0.9 m³ (0.92 to 1.18 cu.yd). Keep 50% of the hopper capacity (measured on the trough) as a feeding target. However do not forget to adjust the feeding amount, watching the condition on the grizzly feeder.

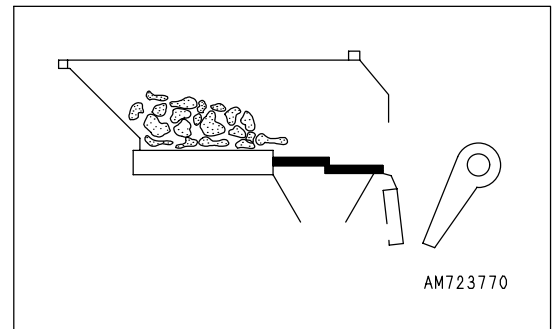
**STEP 2**

Feeding the optimum amount assures that the screen separates soils and sand from concrete debris completely.

Note: Do not feed the next lot of debris immediately.

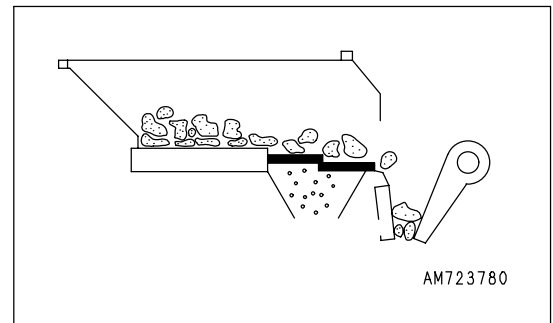
**STEP 3**

When the remaining debris decreased almost to the half, feed the next lot.

Repeat the same practice thereafter.

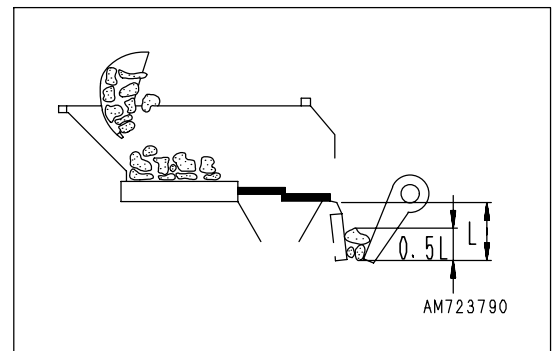

SCOPE OF WORKS USING MOBILE CRUSHER

The mobile crusher can crush concrete debris and natural rocks.

Crushable debris size

- Maximum feedable block dimensions:1200(A) x 600(B) x 950(C) mm (47.3 x 23.6 x 37.4 in)

NOTICE

Break natural rocks into pieces having a size below 600 mm (23.6 in) cube.

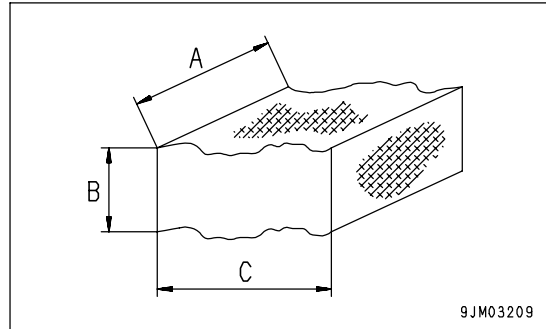

- Optimum feedable block dimensions:600(A) x 350(B) x 350(C) mm (23.6 x 13.8 x 13.8 in)

NOTICE

Break natural stones into pieces having a size of approx. 350 mm (13.8 in) cube.

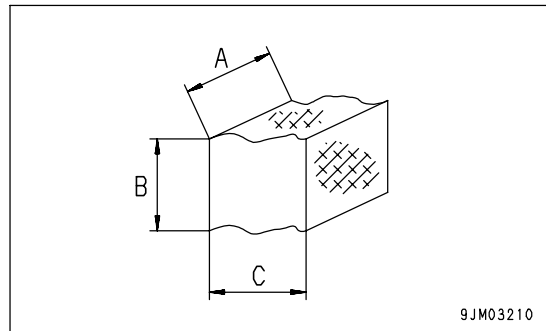

The maximum feedable block dimensions mean the maximum dimensions of a debris block that can be possibly fed into the jaw crusher, if proper attention is paid to the feeding angle, and crushed.

The optimum feedable block dimensions mean the maximum dimensions of debris that can be possibly fed into the jaw crusher without paying attention to the feeding angle, and crushed.

NOTICE

In case a debris exceeding the optimum feedable block dimensions has to be fed into the jaw crusher, set the crusher load setting dial to the SOFT position and start the work. This mode helps reduce the occurrence rate of bridging and blocking in the system, thus raising the work efficiency as a whole.

CRUSHING CONCRETE DEBRIS

NOTICE

Do not feed concrete debris containing reinforcing bars larger than 13 mm (0.5 in) in diameter and longer than 600 mm (23.6 in), since they can damage the machine.

The mobile crusher can crush concrete debris (including reinforced concrete) generated at a building demolition site.

The size of crushed debris may be changed in the range of 55 to 200 mm (2.2 to 7.9 in) in diameter by adjusting the clearance at the outlet of the jaw crusher.

For crushing reinforced concrete debris, install an optional magnetic selector and a belt conveyor protection plate on the machine for higher work efficiency. (See the section of "HYDRAULIC TYPE MAGNETIC SELECTOR (PAGE 6-3)", "BELT CONVEYOR PROTECTIVE PLATE (PAGE 6-26)")

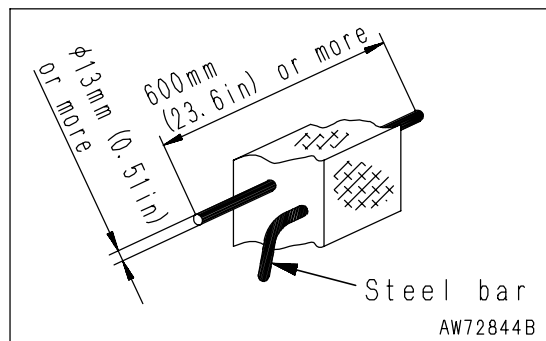

KEEPING SOME HEIGHT UNDER CRUSHER

When crushing reinforced concrete debris, it is advisable to increase the clearance between the crusher underside and the belt conveyor top to ensure good discharge of the debris.

If many long reinforcing bars are contained in the reinforced concrete debris to be crushed, adjust the posture of the primary belt conveyor in the following manner prior to the start of work.

NOTICE

A reinforced concrete debris block larger than 13 mm (0.5 in) in diameter and longer than 600 mm (23.6 in) must not be crushed, since it may damage the crusher.

1. Start the engine.
2. Depress belt conveyor raising and lowering control switch (1) to remove the belt conveyor bar off the mounting hook for work.
3. Stop the engine.

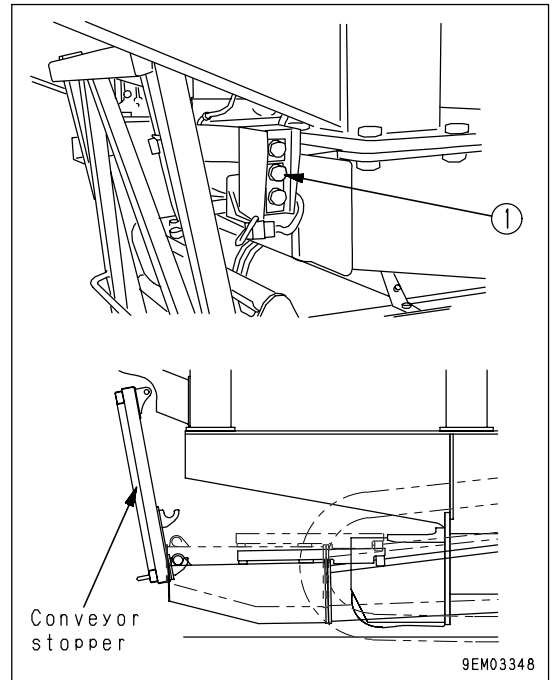

4. Detach the mounting hooks (A) for work that are installed at the lower part of the belt conveyor stopper, and install them again at the 113 mm (4.5 in) lower position.
(Bolt used: M16 x 4 bolts/piece)
(Mounting hook weight: 3.2 kg (7.06 lb)/piece)

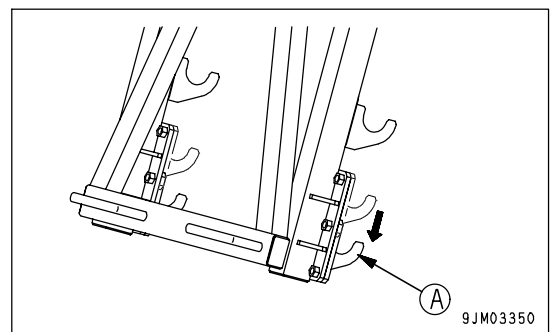

5. Release the belt conveyor stopper and push in the mounting hooks for work under the belt conveyor bar.
6. Start the engine again.

7. Depress the belt conveyor lowering switch to securely hang the belt conveyor bar on the mounting hook for work that was relocated to the lower part.
 With this the machine is ready for crushing reinforced concrete debris.

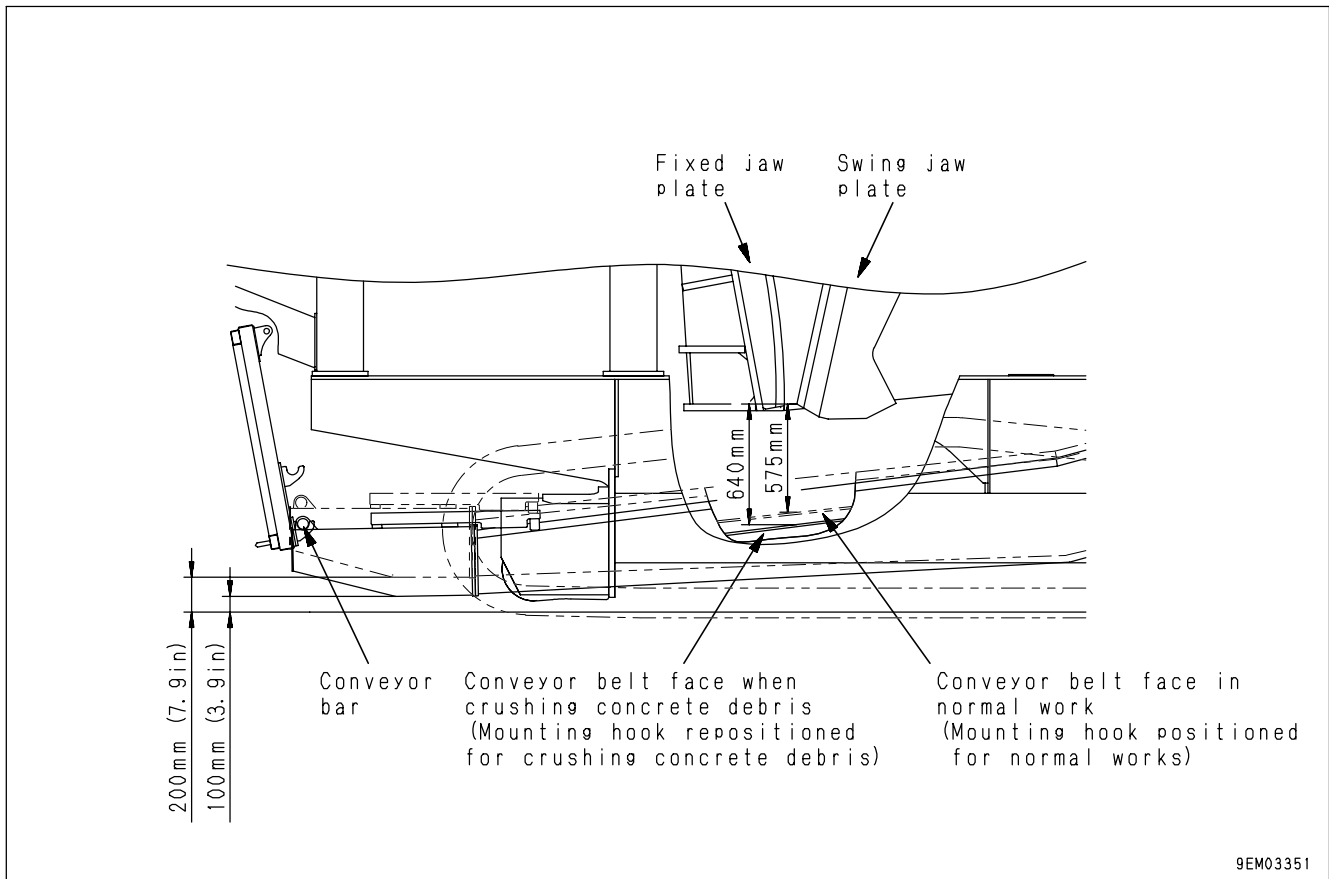

REMOVING REINFORCING BARS FROM CONCRETE BLOCKS

! WARNING

When you have to get in the crusher chamber for removing reinforcing bars , be sure to stop the engine first, then hang a warning tag to the starting switch in the main control box and start the work.

NOTICE

- When crushing reinforced concrete debris, they may remain around the jaw crusher outlet or on the belt conveyor.
 - When crushing them, check that there are no reinforcing bars left around those spots every two to three hours.
 - Remove the remaining reinforcing bars in the following manner to prevent a damage on the machine.
1. In order to secure working space for removing reinforcing bars, set the primary conveyor to a recycling posture, or remove the conveyor frame stopper bar off the conveyor stopper hook, and extend the primary conveyor two-way cylinder to the maximum.
 2. Detach the earth spillage preventive plates provided on both sides of the machine.
 (Bolts used: M12 x 2 bolts/plate)
 (Weight of earth spillage preventive plate :17.2 kg (37.93 lb)/plate)

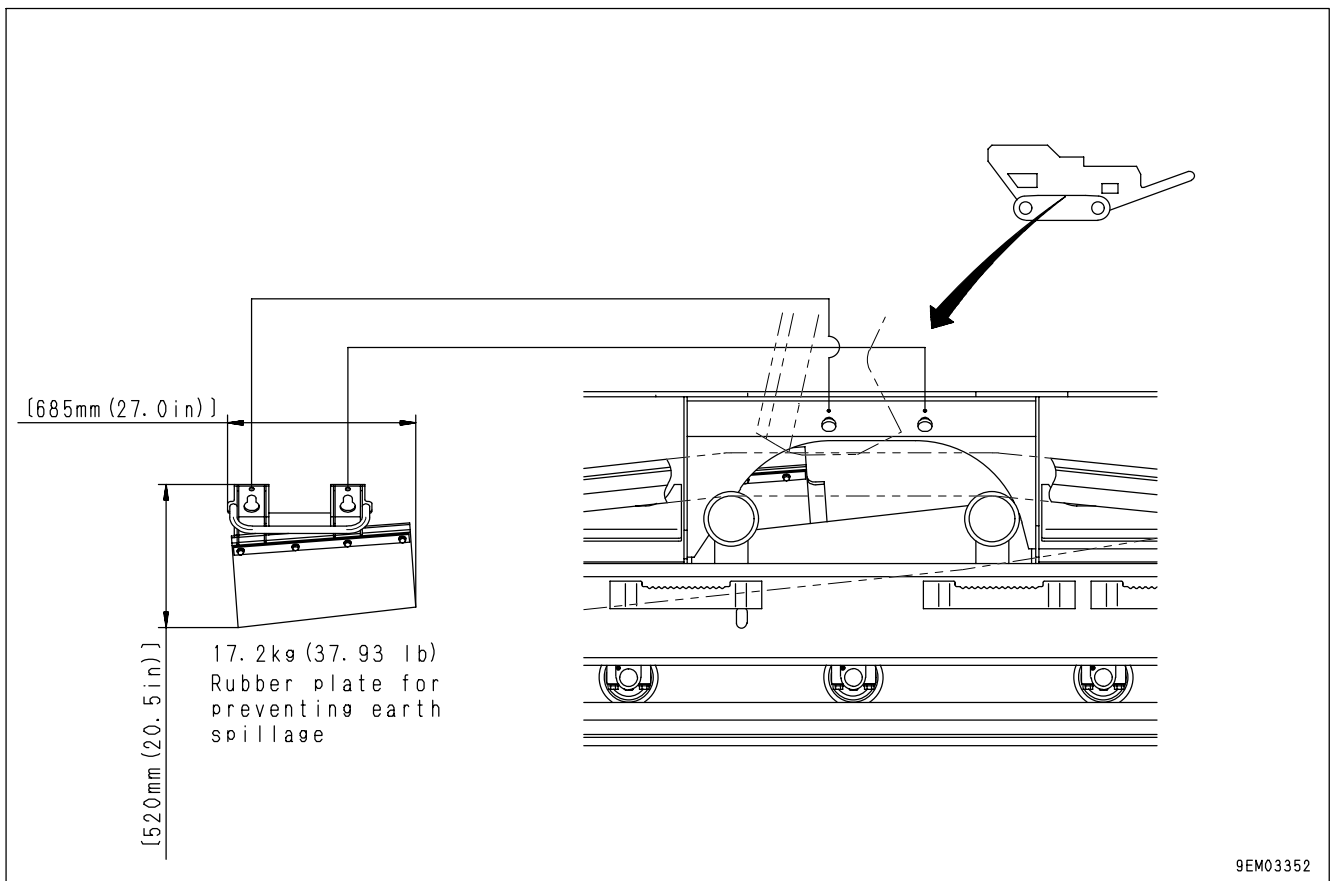

3. Enter the interior of the machine through the side of engine frame to remove the remaining reinforcing bars.

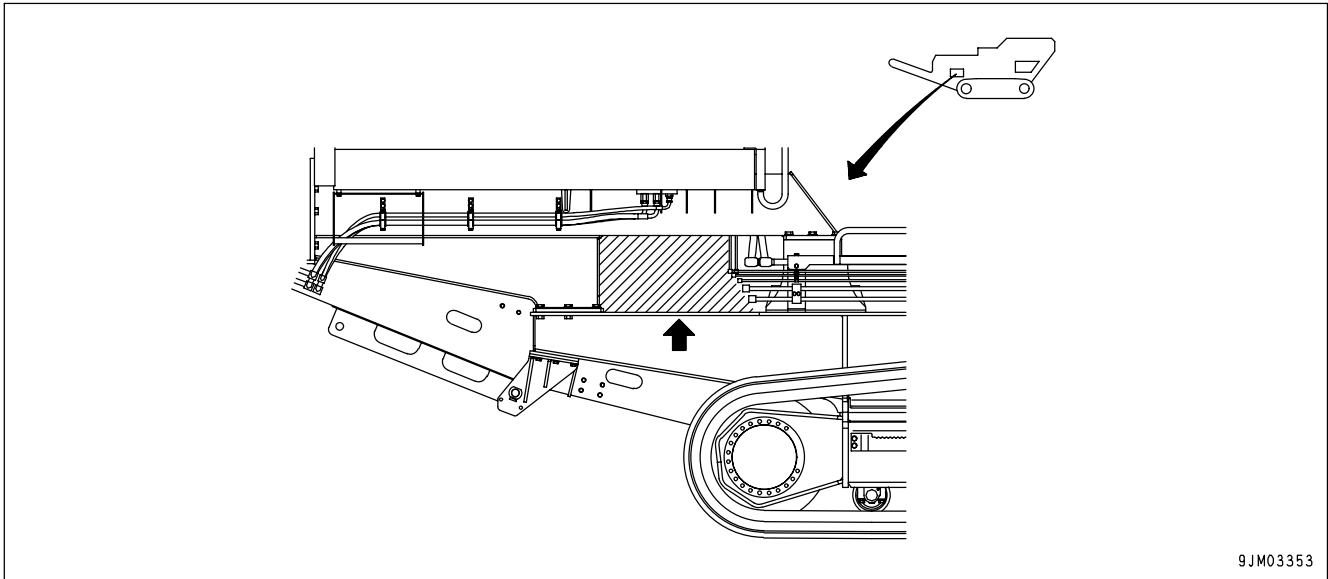

4. After all the reinforcing bars have been removed, attach the earth spillage preventive rubber plates that were detached in Item 2 above.

NOTICE

Be sure to push in the rubber part of the earth spillage preventive plates on to the primary conveyor frame surface after attaching them to the machine.

5. Following the instructions set forth in the section "STARTING JAW CRUSHER OPERATION (PAGE 3-61)", start the work again.

CRUSHING NATURAL ROCKS

NOTICE

- If natural rocks are fed and crushed together with debris of high water content (earth, sand, etc.), not only the grizzly feeder may be clogged, but also the packings at the crusher outlet and fixed and swing jaw crusher plates may be worn out prematurely. To avoid such troubles, use an excavator equipped with a skeleton bucket, when loading debris.
- When crushing natural rocks, do not set the clearance at the crusher outlet in the range of 55 to 100 mm (2.2 to 3.9 in) for fear of damages on the machine and premature wear of the fixed and swing jaw plates.
- When crushing boulders collected in a riverbed, set the crusher speed control dial to the MIN position, thereby preventing them from flying off or floating and eventually enhancing the work efficiency.

The mobile crusher can crush rocks hewn or dug out in quarries and tunnel construction sites as well as boulders collected in a riverbed.

The grain size of crushed debris can be adjusted in the range of 100 to 200 mm (3.9 to 7.9 in) by adjusting the clearance at the jaw crusher outlet.

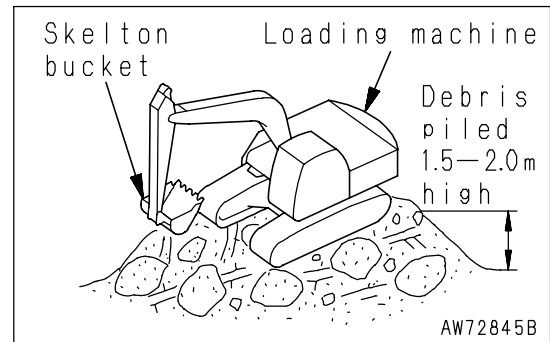

PROHIBITIONS FOR OPERATION

PROHIBITION OF SETTING OUTLET CLEARANCE NARROWER THAN 55 mm

NOTICE

When crushing reinforced concrete debris with OSS setting at 55 mm (2.2 in), never try to feed reinforcing bars larger than 25 mm (1.0 in) in diameter.

The fixed and swing jaw plates will interfere with each other, and the toggle plate and the machine itself will be broken.

If you reduce the clearance at the crusher outlet below 50 mm (2.0 in) by increasing the shim plate thickness, the following problems will result.

- More load will be applied to the jaw crusher main body, which leads to the shorter service life.
- Life of both fixed and swing jaw plates will be shortened.
- The fixed and swing jaw plates will likely interfere with each other.

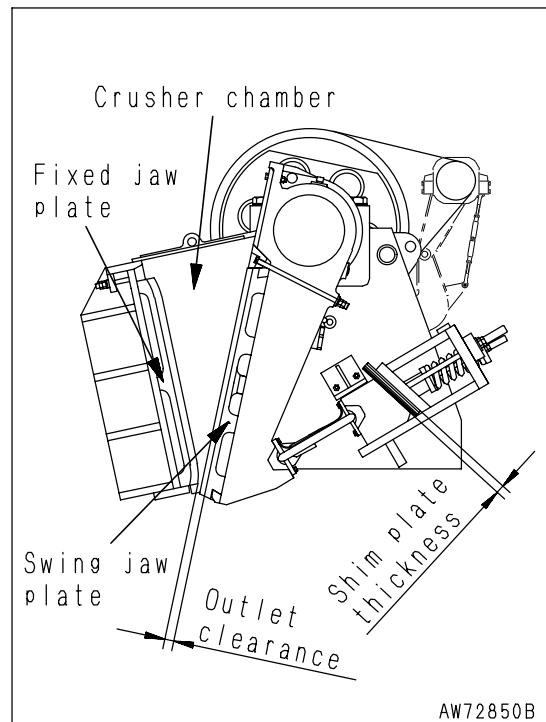

PROHIBITION OF WORK ON SLOPE

NOTICE

- Before starting a crushing work, check that the machine is level both in the fore and aft direction and the right and left direction, using a level fitted to the side of the control box.
Moreover make sure that the machine undercarriage is in firm contact with the ground at the four outermost track rollers.
- If a rock sticks out at the midpoint of the undercarriage (under the primary belt conveyor), the frame and belt of the conveyor may be damaged, when the belt conveyor is set to a working posture.
Level the ground before parking the machine for work.

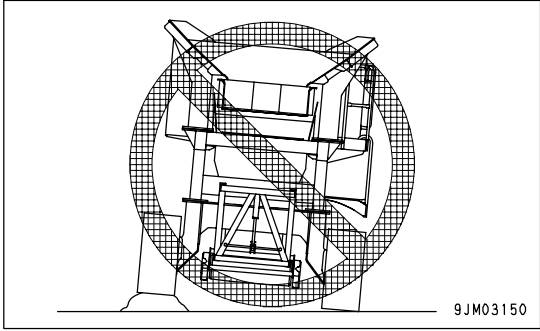

A crushing work on a slope will result in the following problems.

- Since the debris are huddled on one side of the crusher chamber, partial wear develops on the jaw plates.
- The debris crushed in the crusher chamber will not fall down on the center of the primary conveyor belt (partial loading), causing the conveyor to make a snaky movement.
- The machine may start to vibrate abnormally.

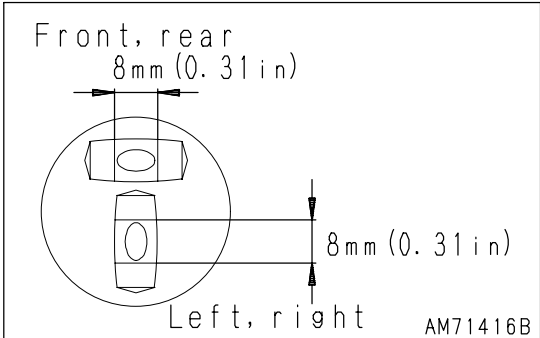
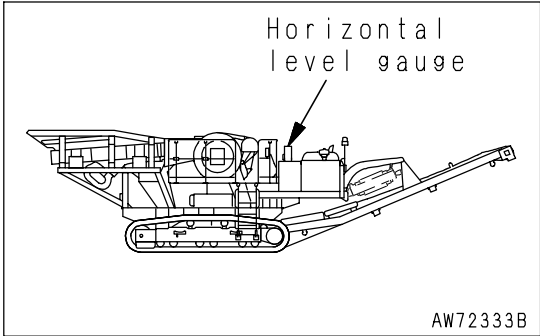

PRECAUTIONS WHEN TRAVELING UP OR DOWNHILLS

DANGER

- Keep the primary conveyor raised, while traveling the machine.
- If the machine has to climb over an obstacle on an unpaved road, lower the travel speed.
- Never try to change the traveling direction on a slope, nor traverse it. Climb down to a flat ground once and make a detour for safety.
- Never try to carry out a work, parking the machine on a slope.
- Do not travel the machine on a slope of more than 25° for fear of machine roll over.

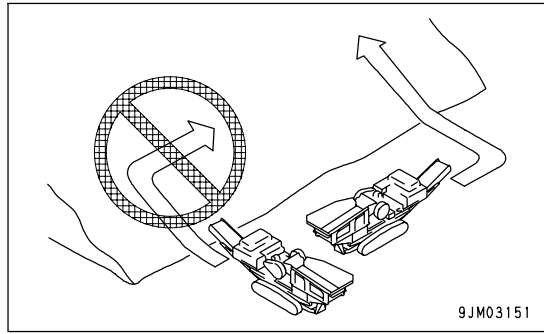

1. When climbing down a steep slope, lower the travel speed with the travel lever and fuel control dial. If a slope exceeds 10°, when climbing down, maintain the the machine posture shown in the figure at right, while keeping a low engine rpm.
2. When climbing up a slope exceeding 10°, maintain the machine posture as shown in the figure at right, wherever possible.

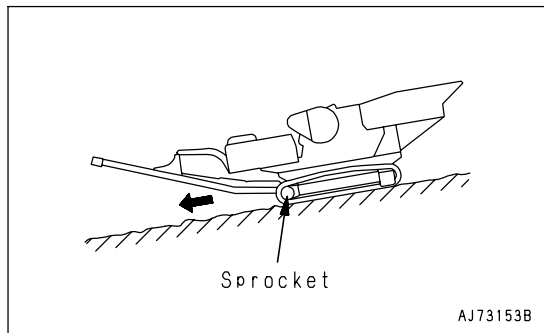

REMARK

In climbing up and down a slope, keep the sprocket facing downward, wherever possible. The track shoe assembly is likely to be loosened, causing shoe jumping in the other way round.

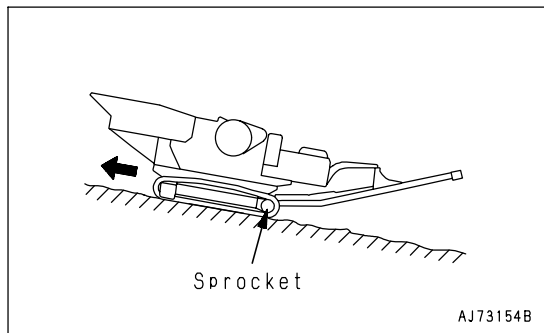

BRAKING AT DOWNHILL TRAVEL

In climbing down a slope, set the travel control lever to the neutral position for activating automatic braking.

IF ENGINE STOPS

If the engine stops while the machine is climbing on a slope, set the travel control lever to the neutral position, stop the machine once, and the start the engine again.

TRANSPORTATION

TRANSPORTATION PROCEDURE

A trailer should be used for transporting the machine.

For the transportation, the machine needs to be disassembled to a certain extent. Consult the Komatsu distributor in your territory for the machine disassembly.

Dimensions and weight for transportation

NO.	Type of Packing		Name of Parts	Weight [kg(lb)]	Weight by Type of Packing [kg(lb)]
1	(1)		Chassis parts	47445 (104616)	47445 (104616)
2	Removed parts	(2)	Patrol light, Mirror A	15 (33.08) [*16 (35.28)]	50 (110) [*51 (112)]
3			Muffler	2 (4.41)	
4			Pre-cleaner A	12 (26.46)	
5			Step	21 (46)	
6	Option	(3)	Magnetic selector A	1744 (3846)	2278 (5023)
7			Debris discharging conveyor	534 (1177)	

*Patrol light (2 pieces, 2 kg (4.41 lb)) must be removed to install optional radio control system.

The machine is to be disassembled into three portions of (1) and (2) for the transportation.

(In case the machine is equipped with any optional work equipment, portions (2) and (3) may be transported together)

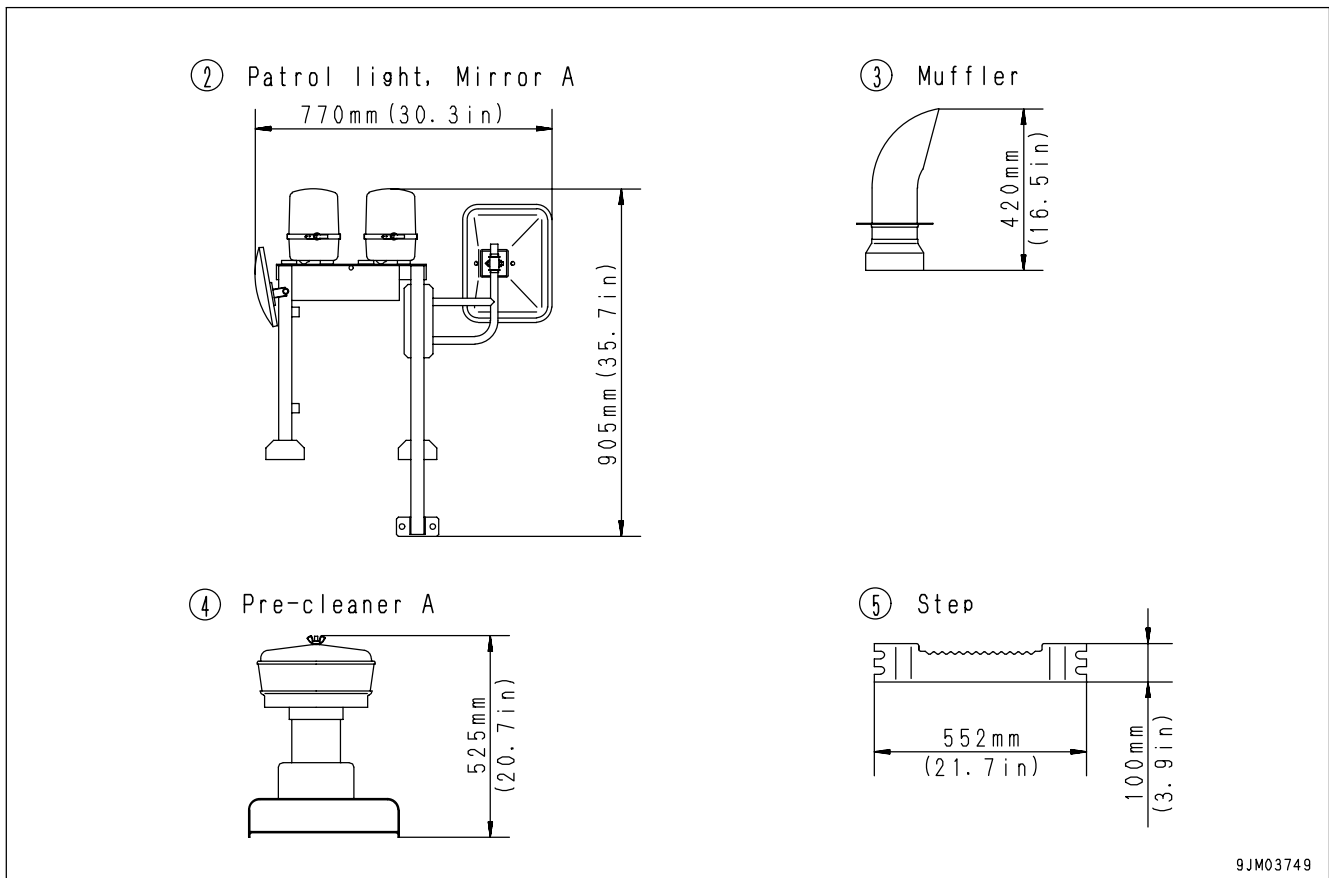
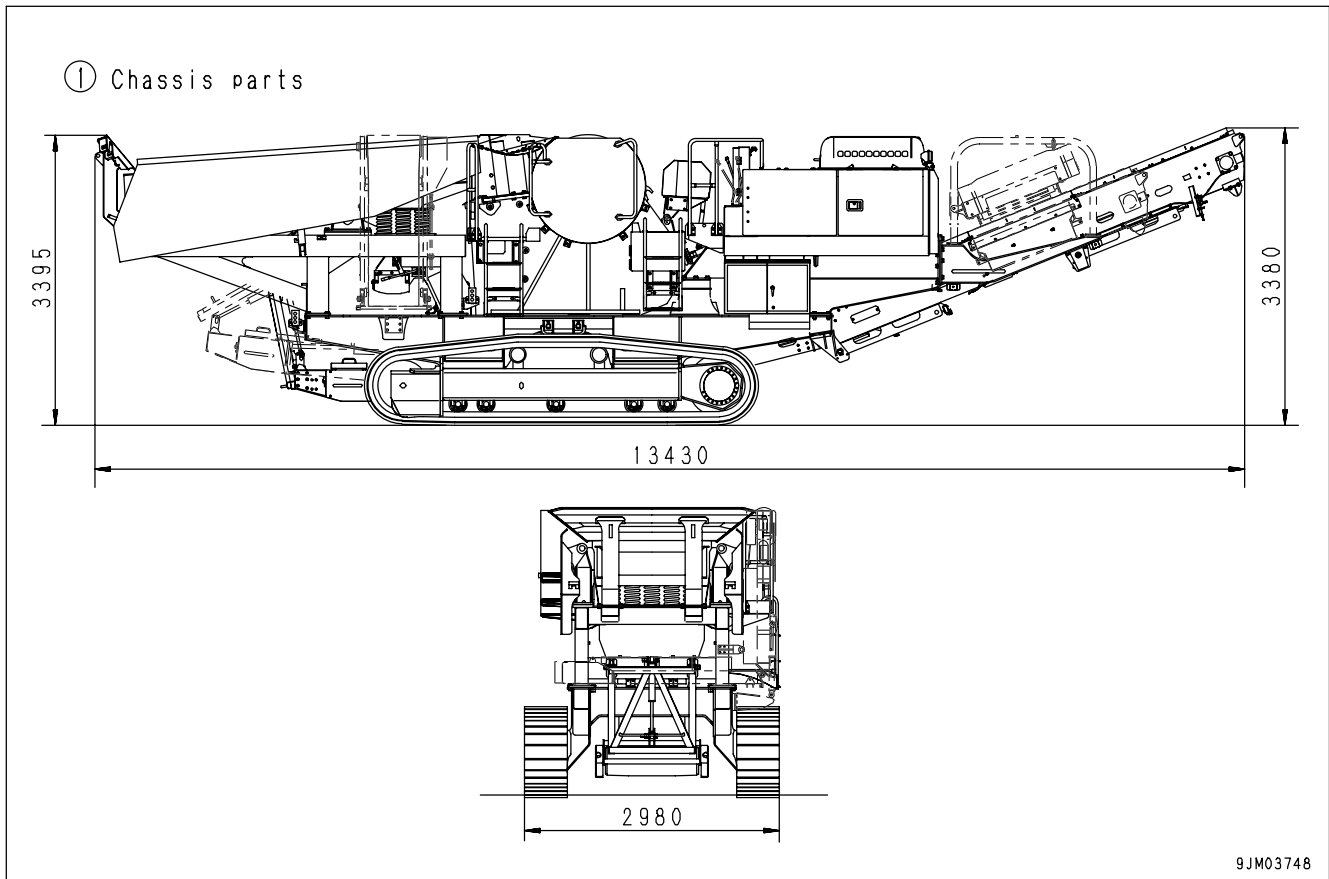

PROCEDURE FOR DISASSEMBLY AND FOLDING



WARNING

- Always stop the engine before carrying out the disassembly work.
- When climbing on top of the feeder to carry out the folding operation of the hopper or to install the lifting tool, always wear a safety belt during the operation.

To conform with the regulations for transportation in the area concerned, do as follows and disassemble and fold the machine.

1. Park the machine on firm level ground.
2. Fold the hopper. For details, see "CHANGE OF MACHINE FROM OPERATION POSTURE TO TRANSPORTATION POSTURE (PAGE 3-69)".
3. Remove 6 bolts, then remove the rotating lamp and mirror A.

NOTICE

There is a connector under the rotating lamp, so remove it before removing the rotating lamp.

4. Remove 4 bolts, then remove the muffler.
5. Remove 4 bolts, then remove the precleaner assembly.

NOTICE

After removing the precleaner assembly, cover the opening of the intake tube to prevent the entry of rain.

6. Remove 4 bolts, then fold over the spray prevention guard.

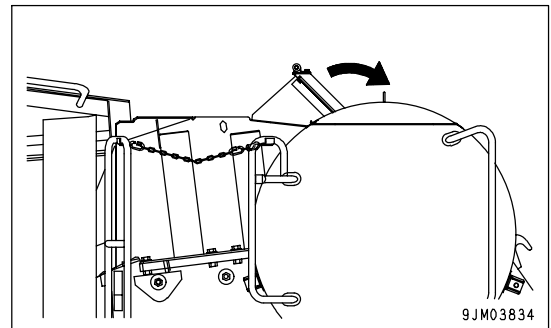

7. Fold the top of the feeder port guard on to the center of the machine.

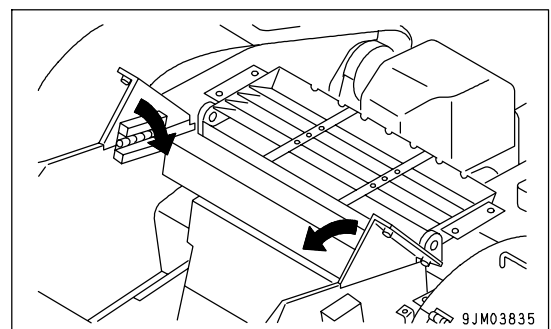

8. Remove 9 bolts, open the portion at the top of the right flywheel cover, then fold it over.

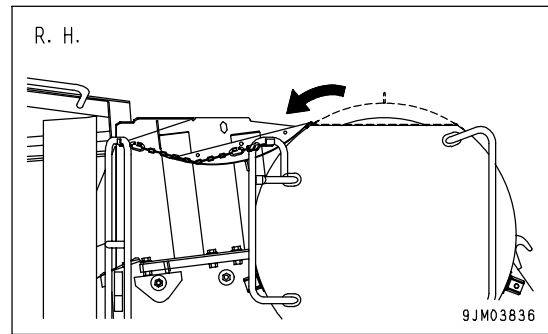

9. Remove 10 bolts, open the portion at the top of the left flywheel cover, then fold it over.

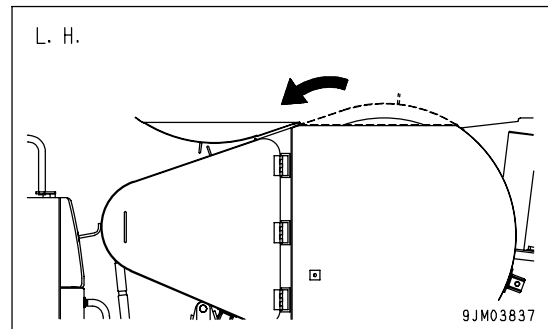

NOTICE

After folding it over, tighten both the left and right covers securely with bolts to hold in position to prevent play during transportation.

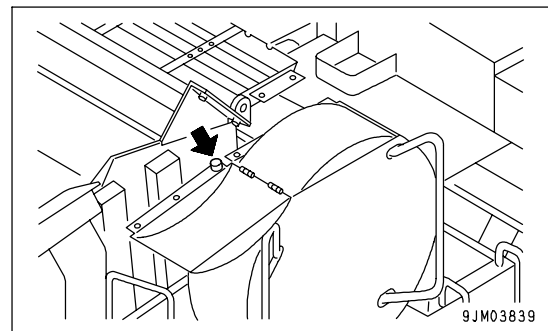

10. Remove the 4 steps installed to the side of the track.
11. Raise the primary belt conveyor and set it to the travel posture. For details, see "MOVING MACHINE (PAGE 3-55)".
12. Assemble in the reverse order from disassembly and folding.

LOADING, UNLOADING WORK

**WARNING**

- When loading or unloading the machine, run the engine at low idling and travel at low speed.
- When loading or unloading the machine, park a trailer on a level and solid roadbed. Moreover keep a good distance between the road shoulder and the machine.
- Make sure that ramps have sufficient width, length and thickness, and securely fix them, inclined at less than 15°.

If an earth mound is employed, firmly compact it so that the slopes will not collapse.

- Remove mud or oil on the undercarriage beforehand so that the machine will not slip off sideways on the ramps. Furthermore remove water, snow, ice, grease, oil, etc. from the ramps, too.

- Never try to change the travel direction on the ramps. Otherwise the machine will slip off them.

Return to the ground or the trailer bed once, and then change the direction.

- Do not operate any other lever than the travel control lever on the ramps.
- The center of gravity of the machine suddenly shifts forward at the connecting point of the ramps and trailer bed, throwing the machine off the balance. Pass it slowly for safety.
- Be sure to install after unloading the rear view mirror, handrails, step, etc. that were removed when the machine was loaded. Don not start a work without them, because it is dangerous, leading to an accident. (This applies to new machines at the time of delivery)

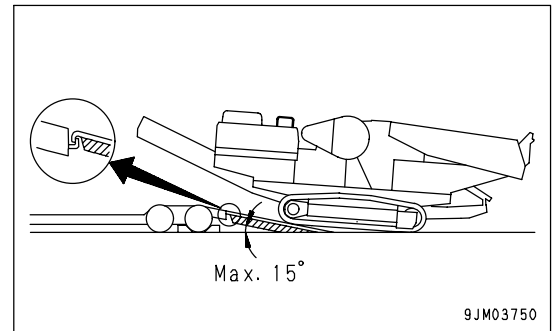

When loading or unloading, always use ramps or a platform. Proceed as follows.

LOADING

1. Load and unload on firm level ground only.
 Maintain a safe distance from the edge of a road.
2. Properly apply the brakes on the trailer and put blocks under the tires to ensure that the trailer does not move.
 Make the slope of the ramps a maximum of 15°.
3. Turn fuel control dial (3) to the left end to slow down the engine revolution.

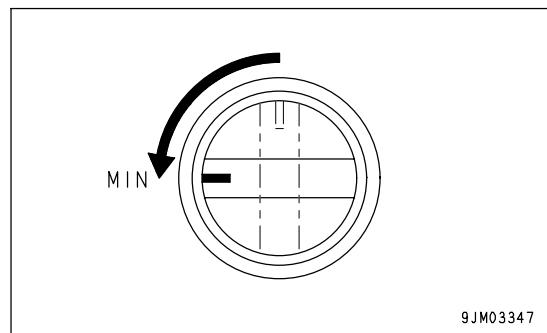
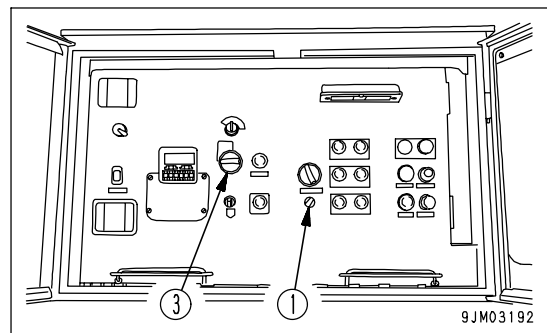
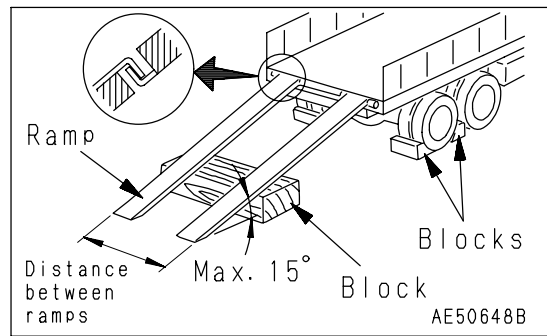

4. Set operation mode selector switch (1) to the "TRAVEL" position and check that the travel lock monitor (2) lamp is off.

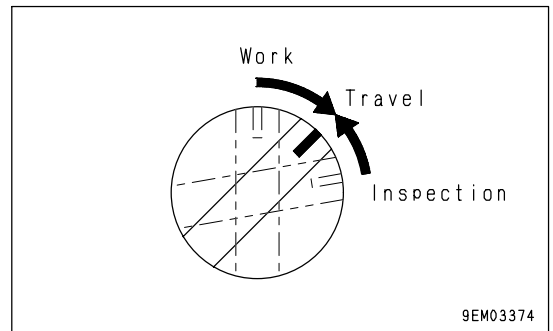
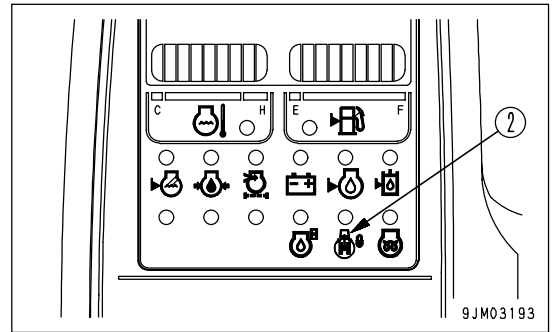

5. Remove the belt conveyor bar off the mounting hook for work by depressing the belt conveyor raising switch (1) on the belt conveyor raising and lowering operation panel.
6. Raise the belt conveyor by depressing belt conveyor raising switch (1) again, while holding up the belt conveyor stopper.

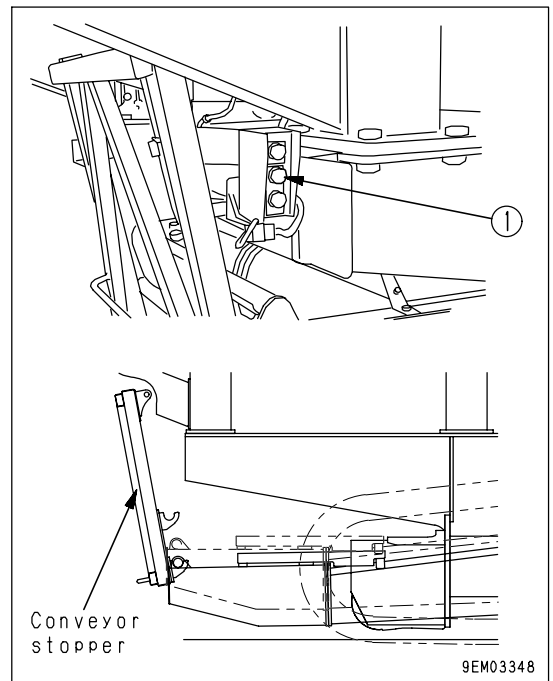

7. When the belt conveyor has been raised completely, keep the hands off the conveyor stopper, and then insert the mounting hook for travel under the conveyor bar.
8. Hang the belt conveyor bar to the mounting hook for travel without fail by depressing the belt conveyor lowering switch.

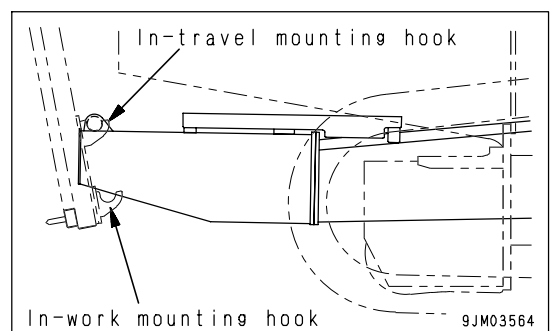

9. Release the travel control lever safety lock.

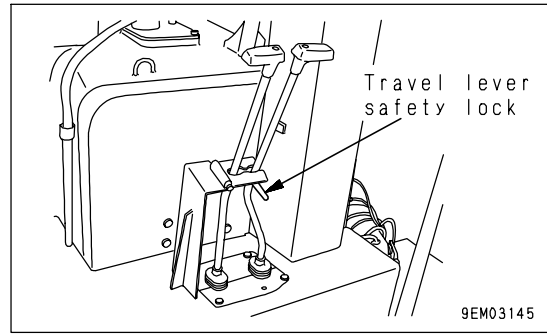

10. Push travel control levers (4) forward slowly for starting the machine.

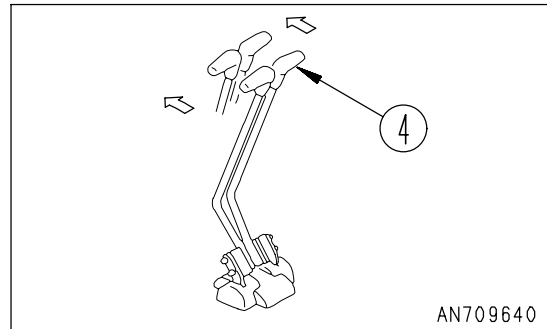

SECURING MACHINE

Load the machine onto a trailer as follows:

1. Stop the machine, when it takes a level posture right above the rear wheels on the trailer bed.
2. Move the machine forward slowly on the trailer.
3. Stop the machine at the specified position on the trailer.
4. Stop the engine, then remove the key from the starting switch.

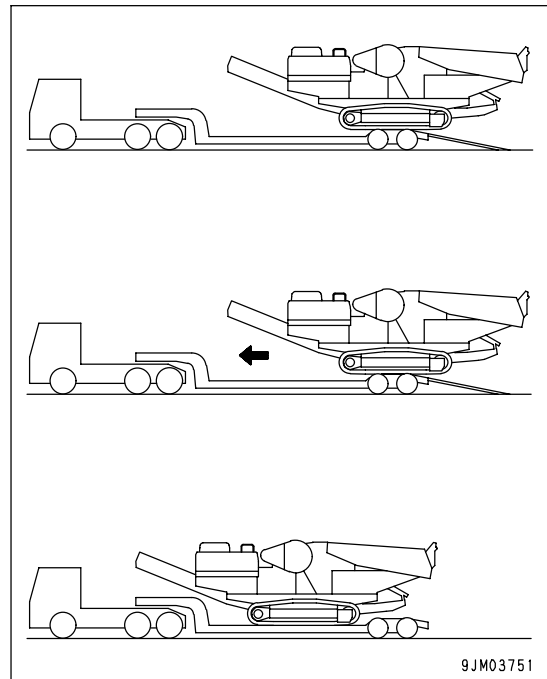

- Lock the travel control levers securely with the travel lever safety lock.

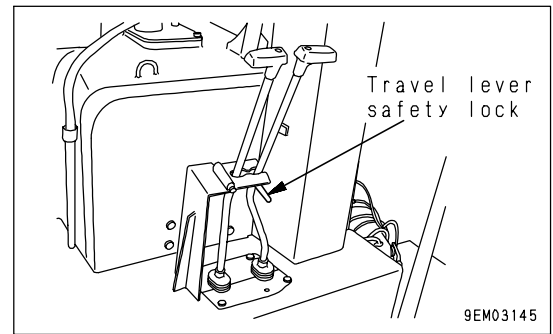

- When transporting the machine, place a rectangular block under the front and rear track shoes to prevent the machine from moving. Furthermore fasten the machine with chains or wire ropes of sufficient strength. Make sure particularly that the machine will not slip sideways.

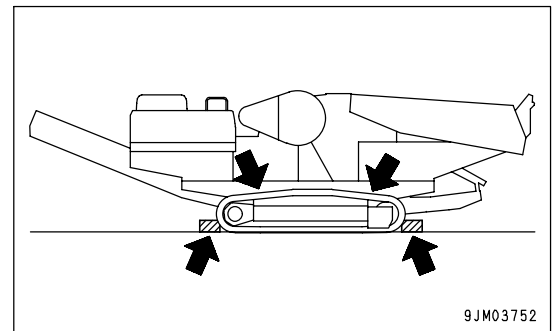

UNLOADING

- Load and unload on firm level ground only. Maintain a safe distance from the edge of a road.
- Properly apply the brakes on the trailer and put blocks under the tires to ensure that the trailer does not move. Make the slope of the ramps a maximum of 15°.

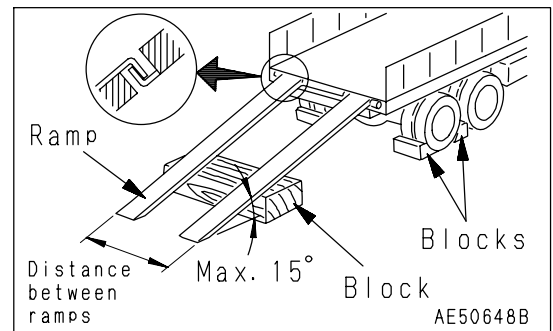

- Remove the chains and wire ropes fastening the machine.
- Start the engine.
Warm the engine up fully.

- 5. Turn fuel control dial (3) to the left end to slow down the the engine revolution.
- 6. Set operation mode selector switch (1) to the "TRAVEL" position and check that the travel lock monitor (2) lamp is off.

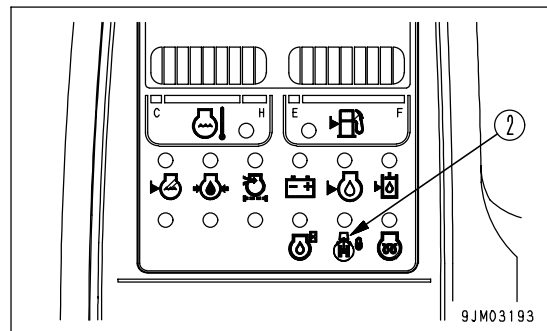
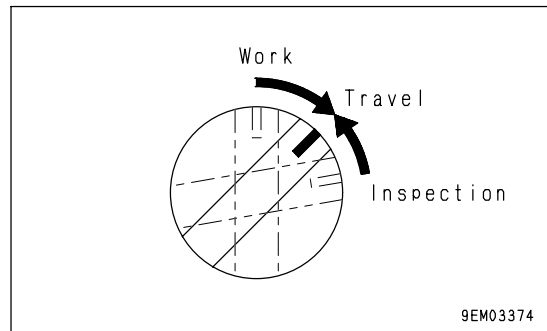
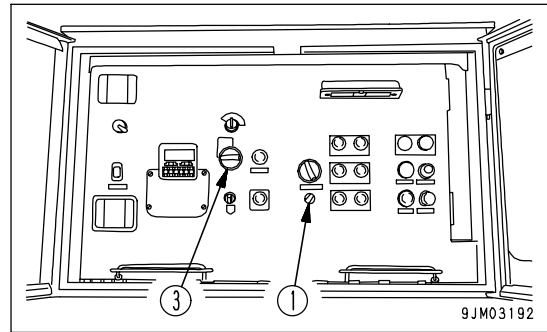

- 7. Release the travel lever safety lock.

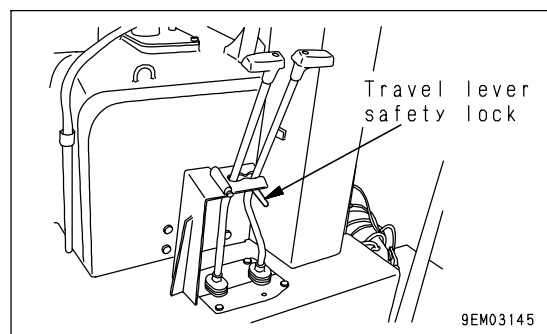

8. Pull travel control lever (4) backward slowly for starting the machine.
9. Turn the machine toward the ramps and travel to them slowly. Never operate any other lever than the travel control levers on the ramps.

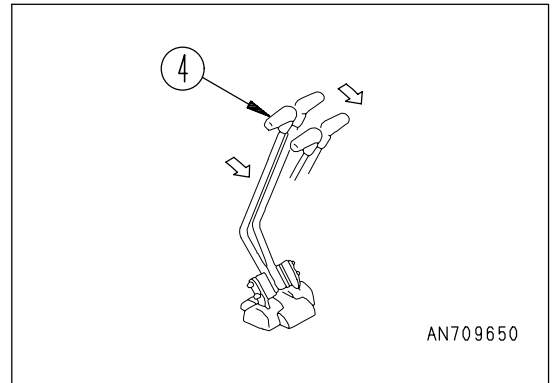

10. Stop the machine, when it takes a level posture right above the rear wheels on the trailer.

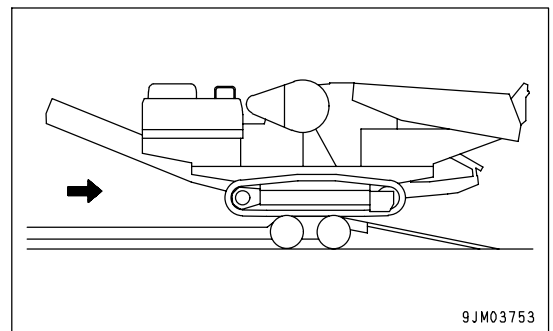

11. When climbing down the ramps, travel slowly, operating the travel control lever gently, until after the machine gets clear of the ramps completely.

LIFTING MACHINE

**WARNING**

- Do not lift the machine with a worker on it.
- For lifting, use a wire rope strong enough to withstand the machine machine weight.
- Do not lift the machine in the other way than illustrated below. Otherwise the machine balance may be lost.
- Strike the balance in lifting the machine, paying attention to the center of gravity.
- Do not go under the lifted machine, as that is dangerous.

When lifting the machine, perform the operation on flat ground as follows:

Fixing machine and lifting posture without disassembly

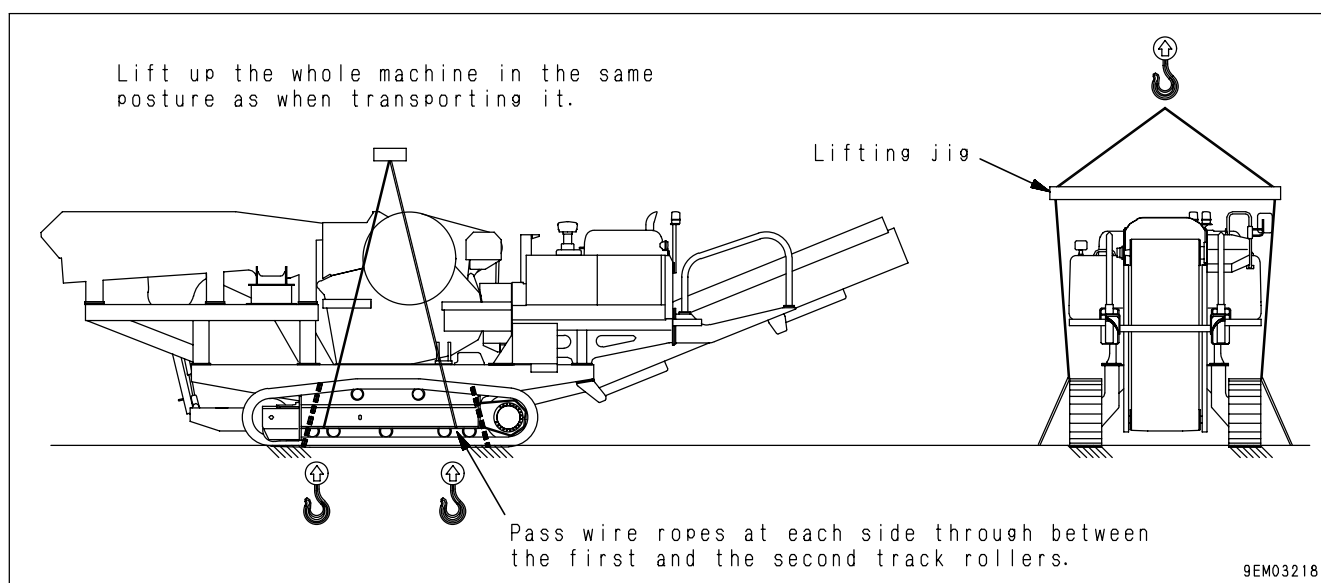
**NOTICE**

- For the details on the machine weight, see the section of "SPECIFICATIONS (PAGE 5-2)".
- The values given in SPECIFICATIONS are based on the standard specifications. The lifting method will differ depending on the actual attachments and options installed on the machine. Contact the komatsu distributor in your territory for more details.

COLD WEATHER OPERATION

PRECAUTIONS FOR LOW TEMPERATURE

If the temperature becomes low, it becomes difficult to start the engine, and the coolant may freeze, so do as follows.

FUEL AND LUBRICANTS

Replace fuel and oil in each component with ones of lower viscosity.

For the details on the specified viscosity, see the section of "USE OF FUEL, COOLANT AND LUBRICANTS ACCORDING TO AMBIENT TEMPERATURE (PAGE 4-14)".

COOLANT



WARNING

Keep antifreeze fluid away from open flames. Never smoke when using antifreeze.

NOTICE

- Never use methanol, ethanol or propanol based antifreeze.
- Avoid using any leak-preventing agent, regardless if it is sold separately or in antifreeze.
- Do not mix one brand of antifreeze with a different brand.

For the timing of engine cooling water replacement and mixing ratio of antifreeze, see the section of "CLEAN INSIDE OF COOLING SYSTEM (PAGE 4-28)".

Use a Permanent Antifreeze (ethylene glycol mixed with corrosion inhibitor, antifoam agent, etc.) meeting the standard requirements as shown below. With permanent antifreeze, no change of coolant is required for a year. If it is doubtful that an available antifreeze meets the standard requirements, ask the supplier of that antifreeze for information.

Standard requirements for permanent antifreeze

- SAE J1034
- FEDERAL STANDARD O-A-548D

BATTERY



WARNING

- To avoid gas explosions, do not bring fire or sparks near the battery.
- Battery electrolyte is dangerous. If it gets in your eyes or on your skin, wash it off with large amounts of water, and consult a doctor.

When the ambient temperature drops, the capacity of the battery will also drop. If the battery charge ratio is low, the battery electrolyte may freeze. Maintain the battery charge as close as possible to 100%. Insulate it against cold temperature to ensure the machine can be started easily the next morning.

REMARK

Measure the specific gravity and calculate the charging rate from the following conversion table.

Charging Rate (%)	Electrolyte Temperature (°C)	20	0	-10	-20
	100		1.28	1.29	1.30
90		1.26	1.27	1.28	1.29
80		1.24	1.25	1.26	1.27
75		1.23	1.24	1.25	1.26

AFTER COMPLETION OF WORK

The undercarriage, belt conveyor and feeder may be frozen due to mud and water on them, hindering the engine from starting up the next morning. To prevent such a trouble, observe the following.

- Remove the mud and water on the machine.
- Park the machine on the hard and dry ground.
If a ground of such conditions is not available, place wooden boards on the ground and park the machine on them. That practice will prevent the undercarriage from being frozen, keeping it off the ground, and the machine can normally be started the next morning.
- Open the drain valve and drain any water collected in the fuel system to prevent it from freezing.
- As the battery capacity drastically drops in low temperatures, cover or remove the battery from the machine, store the battery in a warm place, and install it again the next morning.
- If the electrolyte level is low, add distilled water in the morning before beginning work. Do not add water after the day's work to prevent diluted electrolyte in the battery from freezing during the night.
- The machine can be protected from fast cooling down during the night time either by parking it in a garage or covering it with tarpaulin.
- Disconnect the hose from the water sprinkler nozzle or drain all water in it.

AFTER COLD WEATHER

When the season changes and the weather becomes warmer, do as follows.

- Replace the oil in each component and fuel with those of the designated viscosity, following the instructions set forth in "USE OF FUEL, COOLANT AND LUBRICANTS ACCORDING TO AMBIENT TEMPERATURE (PAGE 4-14)".

- If for any reason permanent antifreeze cannot be used, and an ethylene glycol base antifreeze (winter, one season type) is used instead, or if no antifreeze is used, drain the cooling system completely. Thoroughly flush out the cooling system and fill it with fresh coolant.

LONG-TERM STORAGE

BEFORE STORAGE

When putting the machine in storage for a long time, do as follows.

- Clean and wash all parts, then store the machine indoors. If the machine has to be stored outdoors, select level ground and cover the machine with a sheet.
- Lubricate and change the oil before storage.
- Disconnect the negative terminal of the battery and cover it, or remove from the machine and store it separately.
- If the ambient temperature is expected to drop below -0°C , always add antifreeze to the cooling water. Since Komatsu genuine Super Coolant (AF-ACL) is added to the coolant water normally, it is not necessary to add any other antifreeze as long as the temperature is not expected to drop below -10°C .
If the temperature may drop below -10°C , adjust the density of the coolant according to the section of "CLEAN INSIDE OF COOLING SYSTEM (PAGE 4-28)".
- Grease the exposed surface of piston rods of all the hydraulic cylinders (raising and lowering cylinder of the primary belt conveyor, optional hopper opening and closing cylinder and optional side conveyor storing cylinder).
- Set the travel safety lock to the LOCK position.

DURING STORAGE



WARNING

If it is necessary to perform the rust-prevention operation while the machine is indoors, open the doors and windows to improve ventilation and prevent gas poisoning.

Operate the engine and move the machine for a short distance once a month so that a new film of oil will be coated over movable parts and component surfaces. At the same time, also charge the battery.

AFTER STORAGE

NOTICE

If the machine has been stored without carrying out the monthly rust-prevention operation, consult your Komatsu distributor before using it.

When using the machine after long-term storage, do as follows before using it.

- Wipe off the grease from the hydraulic cylinder rods.
- Be sure to apply oil and grease to all the parts requiring lubrication.

STARTING MACHINE AFTER LONG-TERM STORAGE

- When starting the engine for the first time after a long storage period, observe the following procedures.
 1. Turn the starting switch key to the ON position.
 2. Turn the fuel control dial from the low idling (MIN) position to the full speed (MAX) position, and hold on at that position for three seconds. Then return the dial to the low idling position and start the engine.

TROUBLESHOOTING

PHENOMENA THAT ARE NOT FAILURES

Note that the following phenomena are not failures:

- When the machine travels down a slope at low speed, the travel motor generates noises.

METHOD OF TOWING MACHINE



WARNING

When towing the machine, use a towing wire rope strong enough to withstand the machine weight.

When the machine gets stuck up in mud and cannot climb out on its own, or when towing heavy materials, tow them, using a wire rope, as illustrated at right.

Put a wooden block between the wire rope and the machine to prevent possible damages on the machine and the rope.

Do not use a towing hook for light weight application then.

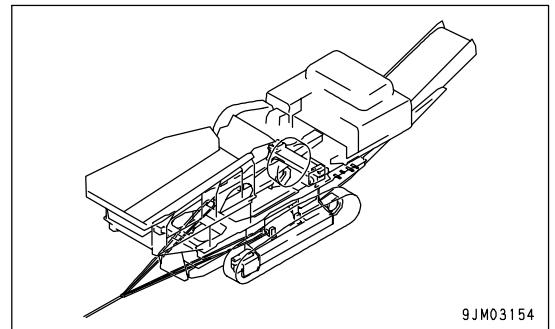

IF BATTERY IS DISCHARGED



WARNING

- It is dangerous to charge a battery when mounted on a machine. Make sure that it is dismantled before charging.
- When checking or handling the battery, stop the engine and turn the starting switch key to the OFF position.
- The battery generates hydrogen gas, so there is a hazard of explosion. Do not bring lighted cigarettes near the battery, or do anything that will cause sparks.
- Battery electrolyte is dilute sulfuric acid, and it will attack your clothes and skin. If it gets on your clothes or on your skin, immediately wash it off with a large amount of water. If it gets in your eyes, wash it out with fresh water and consult a doctor.
- When handling batteries, always wear protective goggles and rubber gloves.
- When removing the battery, first disconnect the cable from the ground (normally the negative (-) terminal). When installing, install the positive (+) terminal first.
If a tool touches the positive terminal and the chassis, there is danger that it will cause a spark, so be extremely careful.
- If the terminals are loose, there is danger that the defective contact may generate sparks that will cause an explosion.
- When removing or installing the terminals, check which is the positive (+) terminal and which is the negative (-) terminal.

When removing, disconnect the cable from the ground terminal first

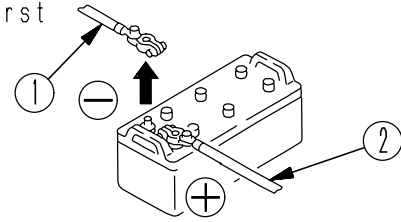

When installing, connect the cable to the positive ⊕ terminal first.

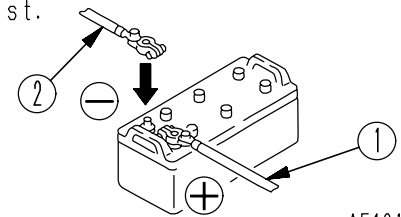

REMOVE AND INSTALL BATTERY

- Before removing the battery, remove the ground cable (normally connected to the negative (-) terminal).
If any tool touches between the positive terminal and the chassis, there is a hazard of sparks being generated.
- When installing the battery, connect the ground cable last.
- When replacing the battery, secure it with battery fitting.
Tightening torque: Tightening battery terminal: 9.8 to 14.7 N·m (1 to 1.5 kgf·m, 7.2 to 10.8 lbft)

PRECAUTIONS FOR CHARGING BATTERY

If the battery is charged improperly, it may explode. Accordingly, charge it according to "IF BATTERY IS DISCHARGED (PAGE 3-112)" and the instruction manual attached to the charger, and observe the following items.

- Set the voltage of the charger to match the voltage of the battery to be charged. If the correct voltage is not selected, the charger may overheat and cause an explosion.
- Connect the positive (+) charger clip of the charger to the positive (+) terminal of the battery, then connect the negative (-) charger clip of the charger to the negative (-) terminal of the battery. Be sure to fix the clips securely.
- Set the charging current to 1/10 of the value of the rated battery capacity; when carrying out rapid charging, set it to less than the rated battery capacity.
If the charger current is too high, the electrolyte will leak or dry up, and this may cause the battery to catch fire and explode.
- If the battery electrolyte is frozen, do not charge the battery or start the engine with a different power source. There is a danger that this will ignite the battery electrolyte and cause the battery to explode.
- Do not use or charge the battery if the battery electrolyte level is below the LOWER LEVEL line. This may cause an explosion. Check the battery electrolyte level periodically and add distilled water to bring the electrolyte level to the UPPER LEVEL line.

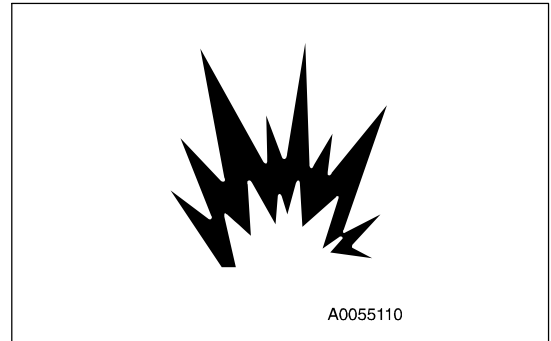

STARTING ENGINE WITH BOOSTER CABLE

When starting the engine with a booster cable, do as follows:

PRECAUTIONS WHEN CONNECTING AND DISCONNECTING BOOSTER CABLE

WARNING

- When connecting the cables, never contact the positive (+) and negative (-) terminals.
- When starting the engine with a booster cable, always wear safety glasses.
- Be careful not to let the normal machine and problem machine contact each other. This prevents sparks from generating near the battery which could ignite the hydrogen gas given off by the battery. If hydrogen gas explodes, it could cause serious injury.
- Make sure you do not make a mistake in connecting the booster cables. Make the final connection to the engine block, be aware that sparks might be generated when this is done, so connect to a place as far as possible from the battery. (However, avoid connecting the cable to the work equipment, as conduction is poor.)
- Use care when removing the cables from the machine that has been started. To avoid hydrogen explosion, do not allow the cable ends to contact each other or the machine.

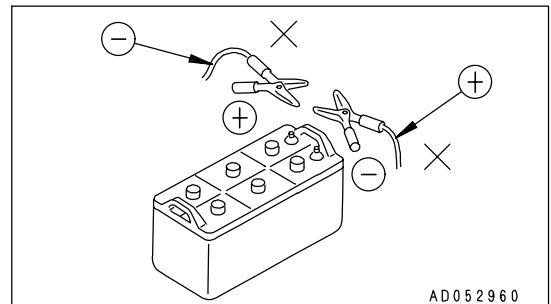

NOTICE

- The size of the booster cable and clip should be suitable for the battery size.
- The battery of the normal machine must be the same capacity as that of the engine to be started.
- Check the cables and clips for damage or corrosion.
- Make sure that the cables and clips are firmly connected.
- Check that the safety lock levers of both machine are in the LOCK position.
- Check that each lever is in the NEUTRAL position.

CONNECTING THE BOOSTER CABLE

Keep the starting switch of the normal machine and problem machine in the OFF position.

Connect the booster cable as follows, in the order of the numbers marked in the diagram.

1. Connect one clip of booster cable (A) to the positive (+) terminal of the problem machine.
2. Connect the other clip of booster cable (A) to the positive (+) terminal of the normal machine.
3. Connect one clip of booster cable (B) to the negative (-) terminal of the normal machine.
4. Connect the other clip of booster cable (B) to the engine block of the problem machine.

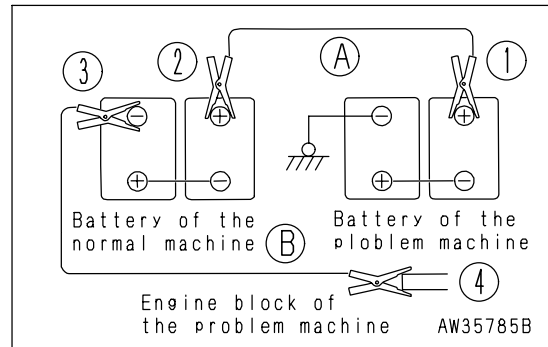

STARTING ENGINE



CAUTION

Check that the travel lever safety lock is set at the LOCK position, irrespective of whether the machine is in a normal condition or broken down.

1. Make sure the clips are firmly connected to the battery terminals.
2. Start engine of the normal machine and run it at high idling speed.
3. Turn the starting switch of the problem machine to the START position and start the engine.
If the engine doesn't start at first, try again after 2 minutes or so.

DISCONNECTING THE BOOSTER CABLE

After the engine has started, disconnect booster cables in the reverse order in which they were connected.

1. Remove one clip of booster cable (B) from the engine block of the problem machine.
2. Remove the other clip of booster cable (B) from the negative (-) terminal of the normal machine.
3. Remove one clip of booster cable (A) from the positive (+) terminal of the normal machine.
4. Remove the other clip of booster cable (A) from the positive (+) terminal of the problem machine.

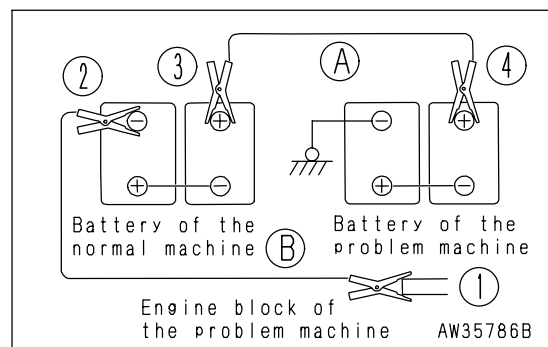

OTHER TROUBLE

CRUSHER AND RELATED ACCESSORIES

- (): Always contact your Komatsu distributor when dealing with these items.
- In cases of problem or causes which are not listed below, contact your Komatsu distributor for repairs.

Abnomal Phenomenon	Major Cause	Corrective Action
Abnormal noise is generated.	• Loosened jaw plate securing bolts	• Retighten
	• Loosened cheek bolts	• Retighten
	• Loosened main body securing bolts	• Retighten
	• Backlash at fixed jaw plate	• Retighten fixed jaw plate wedge bolts
	• Wear or damage on bearings	(• Check and replace)
	• Wear on toggle plate and toggle seat	• Replace with new one
	• Wear on end plate at toggle seat	• Replace with new one.
Vibration is big.	• Backlash at swing jaw plate	• Retighten swing jaw plate wedge bolts.
	• Machine in insufficient contact with ground	• Level the ground
Abnormal heat is generated at bearings.	• Dust mixed in grease	• Check and clean.
	• Improper amount of grease	• Check and add.
	• Machine in poor contact with ground (Machine posture is not level)	• Park machine on flat ground, using a level.

ELECTRICAL SYSTEM

- (): Always contact your Komatsu distributor when dealing with these items.
- In cases of problem or causes which are not listed below, contact your Komatsu distributor for repairs.

Abnormal Phenomenon	Major Cause	Corrective Action
The lamps are dimly lit even with the maximum engine speed.	<ul style="list-style-type: none"> • Wiring fault • Improper belt tension adjustment 	<ul style="list-style-type: none"> • Check and correct loosened terminals and disconnection. • Adjust belt tension.
The lamps flickers while the engine is running.		
The charging level monitor flickers while the engine is running.	<ul style="list-style-type: none"> • Alternator fault • Wiring fault 	<ul style="list-style-type: none"> (• Replace) (• Check and repair)
Abnormal noise is generated in the alternator.	<ul style="list-style-type: none"> • Alternator fault 	<ul style="list-style-type: none"> (• Replace)
The starting motor does not rotate with the engine starting switch turned on.	<ul style="list-style-type: none"> • Battery charging amount shortage • Wiring fault • Starting motor fault • Safety relay fault 	<ul style="list-style-type: none"> • Charge battery (• Check and repair j (• Replace) (• Replace)
The starting motor alternates engagement and disengagement.	<ul style="list-style-type: none"> • Battery charging amount shortage • Safety relay fault 	<ul style="list-style-type: none"> • Charge battery. (• Replace)
The starting motor turns the engine slowly.	<ul style="list-style-type: none"> • Battery charging amount shortage • Starting motor fault 	<ul style="list-style-type: none"> • Charge battery (• Replace)
The starting motor is disengaged before the engine is started.	<ul style="list-style-type: none"> • Wiring fault • Battery charging amount shortage 	<ul style="list-style-type: none"> (• Check and repair) • Charge battery
Preheater monitor does not lights up.	<ul style="list-style-type: none"> • Wiring fault • Heater relay fault • Monitor fault • Glow plug disconnection 	<ul style="list-style-type: none"> (• Check and repair) (• Replace) (• Replace) (• Replace)
Engine hydraulic oil pressure monitor remains lit up for more than three seconds, even after the engine is stopped (with the starting switch ON).	<ul style="list-style-type: none"> • Monitor fault 	<ul style="list-style-type: none"> (• Replace)
Engine hydraulic oil monitor flashes while the engine is running.	<ul style="list-style-type: none"> • Monitor fault • Wiring fault 	<ul style="list-style-type: none"> (• Replace) (• Check and repair)

ENGINE

- (): Always contact your Komatsu distributor when dealing with these items.
- In cases of problem or causes which are not listed below, contact your Komatsu distributor for repairs.

Abnormal Phenomenon	Major Cause	Corrective Action
While the engine is running, the engine oil monitor flickers.	<ul style="list-style-type: none"> • Insufficient amount of oil in oil pan. (Air is sucked) • Clogging in oil filter element • Oil leakage due to improper tightening or damage of oil pipe or pipe joint • Oil pump fault • Engine oil pressure sensor fault 	<ul style="list-style-type: none"> • Add oil up to specified level • Replace elements. (• Check and repair) (• Check and repair) (• Replace.)
Steam blows off from the top (pressure valve) of the radiator.	<ul style="list-style-type: none"> • Insufficient cooling water or water leakage • Loosened fan belt • Dust or sediments accumulated in cooling system 	<ul style="list-style-type: none"> • Check, add cooling water or repair. • Adjust tension • Change cooling water, or clean cooling system.
The red range of the water temperature gauge lights up.	<ul style="list-style-type: none"> • Clogged or crushed radiator fins • Thermostat fault • Loosened radiator filler cap (work at high elevation) • Monitor fault • Cooling water leakage 	<ul style="list-style-type: none"> • Clean or repair (• Replace thermostat) • Retighten cap, or replace packing (• Replace monitor) • Repair.
The engine cannot be started by turning the starting motor.	<ul style="list-style-type: none"> • Insufficient fuel • Air mixed in fuel system • Fuel injection pump fault or nozzle fault • Starting motor turns engine slowly. • Preheater monitor does not light up. • Insufficient compression <ul style="list-style-type: none"> • Valve clearance fault 	<ul style="list-style-type: none"> • Add fuel. • Repair air-mixing spot. (• Replace either pump or nozzle) • Refer to section of electrical accessories. • Refer to section of electrical accessories. (• Adjust valve clearance)
The exhaust color becomes white or bluish.	<ul style="list-style-type: none"> • Excessive oil in oil pan • Fuel of poor quality 	<ul style="list-style-type: none"> • Add fuel up to specified level. • Change fuel for specified one.
The exhaust color sometimes becomes black.	<ul style="list-style-type: none"> • Clogged air cleaner element • Nozzle fault • Insufficient compression 	<ul style="list-style-type: none"> • Clean or replace. (• Replace nozzle) (• Refer to foregoing section of insufficient compression)
The combustion noise sometimes becomes irregular.	<ul style="list-style-type: none"> • Nozzle fault 	<ul style="list-style-type: none"> (• Replace nozzle)
Abnormal noise is generated. (combustion originated or mechanical)	<ul style="list-style-type: none"> • Use of fuel of low quality • Overheating • Internal damage of muffler • Too big valve clearance 	<ul style="list-style-type: none"> • Change for specified fuel. • Refer to foregoing section of "The red range of the water temperature gauge lights up" • Replace muffler. (• Adjust valve clearance)

CHASSIS

- (): Always contact your Komatsu distributor when dealing with these items.
- In cases of problem or causes which are not listed below, contact your Komatsu distributor for repairs.

Abnormal Phenomenon	Major Cause	Corrective Action
Traveling speed, and crusher and conveyor rotating speed are slow.	<ul style="list-style-type: none"> • Insufficient hydraulic oil 	<ul style="list-style-type: none"> • Add oil up to specified level
Hydraulic pump generates abnormal noise.	<ul style="list-style-type: none"> • Clogged strainer element in hydraulic oil tank 	<ul style="list-style-type: none"> • Clean element
Hydraulic oil temperature rises too high.	<ul style="list-style-type: none"> • Loosened cooling fan belt • Contaminated oil cooler • Insufficient hydraulic oil 	<ul style="list-style-type: none"> • Clean belt. • Adjust belt tension. • Add oil up to specified level
Track shoes go off. Sprocket wears abnormally.	<ul style="list-style-type: none"> • Track shoes loosened beyond specified limit 	<ul style="list-style-type: none"> • Adjust tension.

BELT CONVEYOR AND RELATED ACCESSORIES

- Most of the troubles on the belt conveyor may be prevented beforehand, because they are often caused by improper operation and maintenance. A simple inspection allows the belt conveyor to prolong the service life and to demonstrate the performance to a maximum.

Abnormal Phenomenon	Major Cause	Corrective Action
Conveyor belt		
Not operable	<ul style="list-style-type: none"> • Electric circuit fault • Connection fault 	<ul style="list-style-type: none"> • Correct wiring. • Insert connection properly.
Snaky movement	<ul style="list-style-type: none"> • Misalignment of rollers and improper mounting • Debris transport direction • Debris stuck to rollers (Likewise wire or string winding about rollers) • Belt elongation • Belt bending, or not installed properly in endless processing • Frame twisting and bending • Frame not poised evenly (Belt is deflected to lower side) • Belt too rigid (Wrong belt chosen) 	<ul style="list-style-type: none"> • Adjust roller mounting angle. • Load debris evenly in the middle of the belt, after making sure that the machine is kept level on the ground. • Clean roller periphery. • Adjust belt tension with take-up. • Retry endless processing, or replace belt with new one. • Correct twisting and eccentricity at time of assembly or machine installation. • Correct twisting and eccentricity at time of assembly or machine installation. • a. Run in belt without load. • b. replace with softer (proper) belt.
Abnormal wear on backside	<ul style="list-style-type: none"> • Slip on motor pulley (or driving pulley) surface • Debris or foreign object stuck in between belt and pulley (Foreign objects stuck on pulley surface) • Faulty rotation of rollers 	<ul style="list-style-type: none"> • Correct belt elongation with take-up. • a. Remove foreign objects. (Remove sticking) • b. Improve loading conditions at loading part. • Replace faulty rollers.
Damage (fissure in vertical direction)	<ul style="list-style-type: none"> • Debris or foreign objects caught where belt contacts hopper, scraper, etc. • Rollers falling off from bracket and bracket coming to direct contact belt • Rollers of faulty rotation worn out and perforated • Shock due to drop of large and heavy mass • Edged debris 	<ul style="list-style-type: none"> • Remove foreign objects. • Insert rollers into bracket correctly. • Replace faulty rollers. • Devise to alleviate shock, or ensure right load. • Do not let such materials be transported.
Abnormal elongation	<ul style="list-style-type: none"> • Too strong take-up • Transport of hot materials • Abnormal load • End of service life 	<ul style="list-style-type: none"> • Return to normal tension. • Replace with heat-resistant belt. • Ensure proper load. • Replace with new belt.

Abnormal Phenomenon	Major Cause	Corrective Action
Warping	<ul style="list-style-type: none"> • Oily debris (Warping to lower cover side) • Transport of hot materials • Acid content or alkali content included in debris 	<ul style="list-style-type: none"> • Remove cause for oil to mix with debris, or use oil-resistant belt. • Use heat-resistant belt. • Use acid-resistant or alkali-resistant belt.
Scraper belt		
Wear and damage	<ul style="list-style-type: none"> • Debris caught 	<ul style="list-style-type: none"> • a. Remove caught-in debris and correct scraper rubber mounting so as to evenly contact belt. • b. Replace with new one.
Rollers		
Abnormal sound Breakage	<ul style="list-style-type: none"> • Faulty rotation of rollers • Wire or string winding about shafts Shock due to fall of large and heavy mass 	<ul style="list-style-type: none"> • Replace with new one. • Remove foreign objects. Take measures to ensure proper lump size and weight to alleviate shock.
Motor		
Faulty operation	<ul style="list-style-type: none"> • Insufficient hydraulic oil 	<ul style="list-style-type: none"> • a. Add oil up to specified level. • b. Replace or repair.

ELECTRONIC CONTROL SYSTEM AND RELATED ACCESSORIES

Monitor Display	Failure Mode	Corrective Action
E02	Error in TVC valve system	Turn pump redundancy switch on and normal work can be started. But have machine inspected promptly. (*)
E05	Error in speed governor system	Governor controller is incapacitated. Operate governor manually. For fixing at full speed, fixing bolt hole is provided on the bracket. In this case, have governor inspected promptly.
CALL	Error disabling work to continue	Set machine in safe posture and receive inspection promptly.
Unable to operate the work equipment or turn the machine without display of an error code		Ask for inspection promptly.

(*)For how to use the emergency pump starting switch, see the section of "SWITCHES (PAGE 3-16)"

FAILURE DISPLAY BY LX CONTROLLER

If an error code is shown in the display of any work equipment controller, contact the Komatsu distributor in your territory, informing the error code and asking for a prompt inspection.

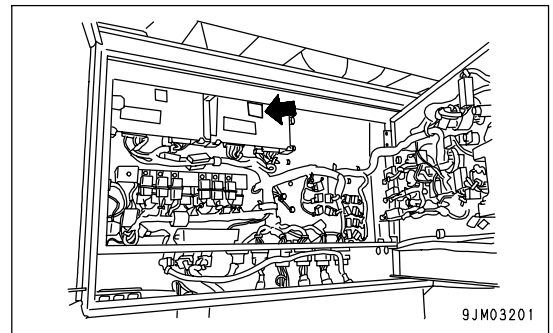

• LX controller error codes

The LX controller indicates an error code with two led, when something unusual takes place. When it is turned on, the following display appears on the screen.

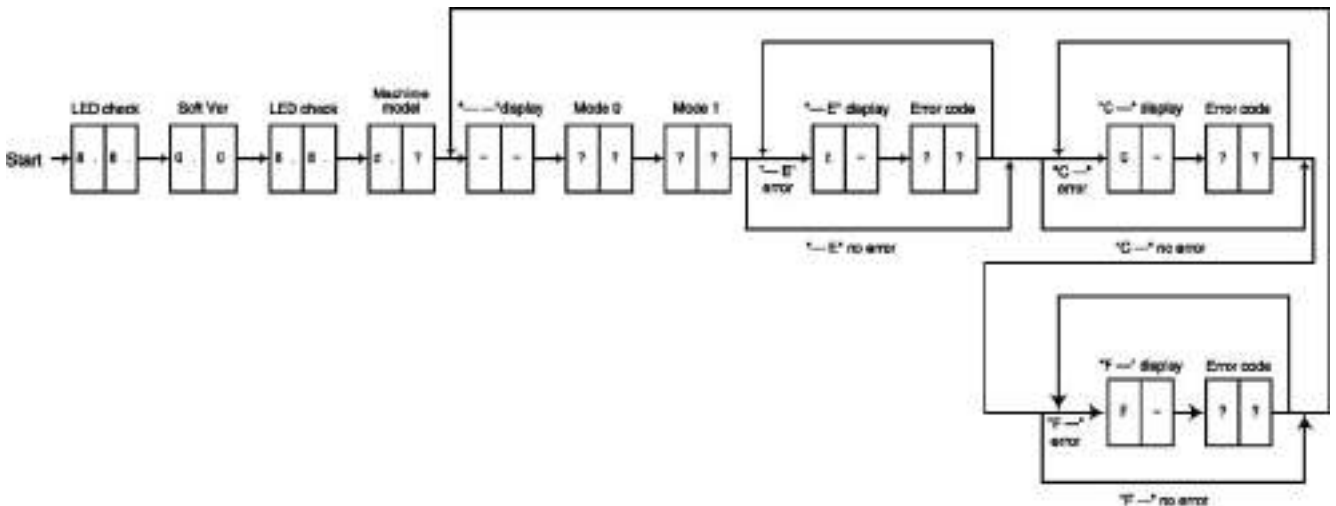

MAINTENANCE

WARNING

Please read and make sure that you understand the SAFETY section before reading this section.

GUIDE TO MAINTENANCE

Do not perform any inspection and maintenance operation that is not found in this manual.
Stop the machine on flat hard ground when performing inspections and maintenance.

CHECK SERVICE METER:

Check the service meter reading every day to see if the time has come for any necessary maintenance to be performed.

KOMATSU GENUINE REPLACEMENT PARTS:

Use Komatsu genuine parts specified in the Parts Book as replacement parts.

KOMATSU GENUINE LUBRICANTS:

For lubrication of the machine, use the Komatsu genuine lubricants. Moreover use oil of the specified viscosity according to the ambient temperature.

CLEAN OIL AND GREASE:

Use clean oil and grease. Also, keep the containers of the oil and grease clean. Keep foreign materials away from oil and grease.

CHECKING FOREIGN MATERIALS IN DRAINED OIL:

After oil is changed or filters are replaced, check the old oil and filters for metal particles and foreign materials. If large quantity of metal particles or foreign materials are found, always report to the person in charge, and carry out suitable action.

FUEL STRAINER:

If an oil filler port is equipped with a strainer, do not remove it, when adding oil.

WELDING INSTRUCTIONS:

- Turn off the engine starting switch.
- Do not apply more than 200 V continuously.
- Connect grounding cable within 1 m (3.3 ft) of the area to be welded. If grounding cable is connected near instruments, connectors, etc., the instruments may malfunction.
- If a seal or bearing happens to come between the part being welded and grounding point, change the grounding point to avoid such parts.
- Do not use the area around the work equipment pins or the hydraulic cylinders as the grounding point.

DO NOT DROP THINGS INSIDE MACHINE:

- When opening inspection windows or the oil filler port of the tank to carry out inspection, be careful not to drop nuts, bolts, or tools inside the machine.
If such things are dropped inside the machine, it may cause damage and/or malfunction of the machine, and will lead to failure. If you drop anything inside the machine, always remove it immediately.
- Do not put unnecessary things in your pockets. Carry only things which are necessary for inspection.

DUSTY WORKSITES:

When working at dusty worksites, do as follows:

- Inspect the air cleaner clogging monitor frequently to see if the air cleaner is clogged.
Clean the air cleaner element at a shorter interval than specified.
- Clean the radiator core frequently to avoid clogging.
- Clean and replace the fuel filter frequently.
- Clean electrical components, especially the starting motor and alternator, to avoid accumulation of dust.

- When inspecting or changing the oil, move the machine to a place that is free of dust to prevent dirt from getting into the oil.

AVOID MIXING OILS:

If a different brand or grade of oil has to be added, drain the old oil and replace all the oil with the new brand or grade of oil. Never mix different brand or grade of oil.

LOCKING THE INSPECTION COVER:

Lock inspection cover securely into position with the lock bar. If inspection or maintenance is performed with inspection cover not locked in position, there is a danger that it may be suddenly blown shut by the wind and cause injury to the worker.

HYDRAULIC SYSTEM - AIR BLEEDING:

When a hydraulic component is repaired or replaced, or when a hydraulic piping is removed, bleeding air from the hydraulic circuit is required. See the section of AIR-BLEEDING FROM HYDRAULIC CIRCUIT (PAGE 4-8) for the air bleeding.

HYDRAULIC HOSE INSTALLATION:

- When removing parts at locations where there are O-rings or gasket seals, clean the mounting surface, and replace with new parts.
When doing this, be careful not to forget to assemble the O-rings and gaskets.
- When installing the hoses, do not twist or bend them into loops with a small radius.
This will cause damage to the hose and drastically reduce its service life.

CHECK AFTER INSPECTION AND MAINTENANCE WORKS:

If you forget to perform the checks after inspection and maintenance, unexpected problems may occur, and this may lead to serious injury or property damage. Always do the following:

- Checks after operation (with engine stopped)
 - Have any inspection and maintenance points been forgotten?
 - Have all inspection and maintenance items been performed correctly?
 - Have any tools or parts been dropped inside the machine? It is particularly dangerous if parts are dropped inside the machine and get caught in the lever linkage mechanism.
 - Is there any leakage of coolant or oil? Have all nuts and bolts been tightened?
- Checks when operating engine
 - For details of the checks when operating the engine, see "PROPER TOOLS (PAGE 2-33)" and pay careful attention to safety.
 - Are the inspection and maintenance items working properly?
 - Is there any leakage of fuel or oil when the engine speed is raised?

OUTLINE OF SERVICE

HANDLING OIL, FUEL, COOLANT, AND PERFORMING OIL CLINIC

OIL

- Oil is used in the engine and hydraulic equipment under extremely severe conditions (high temperature, high pressure), and deteriorates with use.
Always use oil that matches the grade and temperature for use given in the Operation and Maintenance Manual. Even if the oil is not dirty, always change the oil after the specified interval.
- Oil corresponds to blood in the human body, so always be careful when handling it to prevent any impurities (water, metal particles, dirt, etc.) from getting in.
The majority of problems with the machine are caused by the entry of such impurities.
Take particular care not to let any impurities get in when storing or adding oil.
- Never mix oils of different grades or brands.
- Always add the specified amount of oil.
Having too much oil or too little oil are both causes of problems.
- If the oil in the hydraulic oil circuit of the work equipment becomes murky, the cause may be attributed to water or air entered the circuit. Consult the Komatsu distributor in your territory.
- When changing the oil, always replace the related filters at the same time.
- Komatsu oil analysis service is recommended so as to grasp the machine condition periodically. Contact the Komatsu distributor in your territory, if it is required.

FUEL

- The fuel pump is a precision instrument, and if fuel containing water or dirt is used, it cannot work properly.
- Be extremely careful not to let impurities get in when storing or adding fuel.
- Always use the fuel specified in the Operation and Maintenance Manual.
Fuel may congeal depending on the temperature when it is used (particularly in low temperature below -15°C (5 °F)). It is necessary to use the fuel that is suitable for the temperature.
- To prevent the moisture in the air from condensing and forming water inside the fuel tank, always fill the fuel tank after completing the day's work.
- Before starting the engine, or when 10 minutes have passed after adding fuel, drain the sediment and water from the fuel tank.
- When the machine runs out of fuel, or when a filter element has been replaced, bleeding air from the fuel system is required.

COOLANT

- River water contains a large amount of calcium and other impurities. When using it for coolant, scale will stick to the engine cooling parts and radiator, reducing the efficiency of heat exchange which will cause engine overheating.

Do not use such water for cooling the engine that is not fit for drinking.

- When using antifreeze, always observe the precautions given in the Operation and Maintenance Manual.
- Komatsu new machines are shipped out with the Komatsu original antifreeze in the cooling system.
The Komatsu antifreeze is effective at preventing corrosion from developing on the engine cooling system. It need not be removed, even when the machine is used in a temperate climate.
Moreover it can be used for two years or 4000 hours of operation continuously.
- Antifreeze is flammable, so be extremely careful not to expose it to flame or fire.
- Ratio of antifreeze differs according to the ambient temperature. For the proper mixing ratio, see the section of "CLEAN INSIDE OF COOLING SYSTEM (PAGE 4-28)".
- If the engine overheats, wait for the engine to cool before adding coolant.
- If the coolant level is low, it will cause overheating, and will also cause problems with corrosion due to air entering the coolant.

GREASE

- Grease is used to prevent seizure and noises at the joints.
- Those grease fittings, which are not shown in the chapter of MAINTENANCE in the manual, are provided only for overhauling the machine, and as such there is no need to grease them.
If twisting or friction noise is heard after a long operation of the machine, add grease.
- Always wipe off all of the old grease that is pushed out when greasing.
Be particularly careful to wipe off the old grease in places where sand or dirt sticking in the grease would cause wear of the rotating parts.

CARRYING OUT KOWA (Komatsu Oil Wear Analysis)

KOWA is a maintenance service that makes it possible to prevent machine failures and downtime. With KOWA, the oil is periodically sampled and analyzed. This enables early detection of wear of the machine drive parts and other abnormalities.

We strongly recommend you to use this service. The oil analysis is carried out at actual cost, so the cost is low, and the results of the analysis are reported together with recommendations which will reduce repair costs and machine downtime.

KOWA ANALYSIS ITEMS

- Measurement of density of metal wear particles
This uses an ICP (Inductively Coupled Plasma) analyzer to measure the density of iron, copper, and other metal wear particles in the oil.

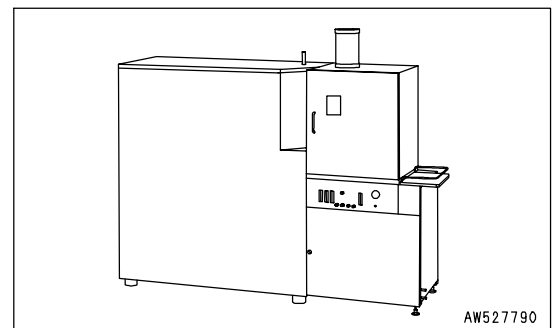

- Measurement of quantity of particles

This uses a particle quantifier index measurement machine to measure the quantity of iron particles of 5µ or more, enabling early detection of failures.

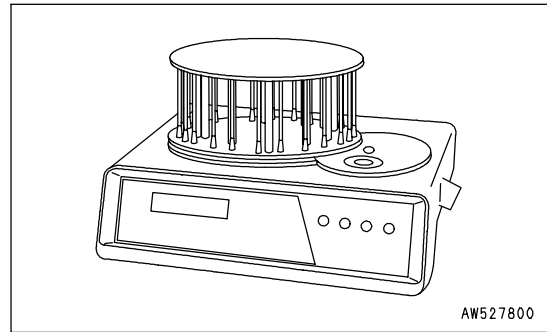

- Others

Measurements are made of items such as the ratio of water in the oil, density of the antifreeze coolant, ratio of fuel in the oil, and dynamic viscosity, enabling a highly precise diagnosis of the machine's health.

OIL SAMPLING

- Sampling interval

250 hours: Engine

500 hours: Other components

- Precautions when sampling

- Make sure that the oil is well mixed before sampling.
- Perform sampling at regular fixed intervals.
- Do not perform sampling on rainy or windy days when water or dust can get into the oil.

For further details of KOWA, please contact your Komatsu distributor.

STORING OIL AND FUEL

- Keep oil and fuel indoors for fear that impurities such as water and dust mix with them.

If it becomes unavoidable to keep them outdoors, exercise a good care for safe-keeping by covering them with a tarpaulin.

- Practice the first-in first-out rule, when supplying oil, in order to avoid the deterioration in quality that is likely to happen due to a long storage.

FILTERS

- Filter elements are critical parts that serve as a safety valve, preventing impurities contained in oil, fuel or air suction system from entering important components and causing various troubles.

Replace them periodically according to the operation and maintenance manual.

The specified replacement interval may have to be shortened, depending on the prevailing machine working conditions, oil and fuel in use (high sulphur content).

- Never try to clean the filters (cartridge type) and use them again. Always replace with new filters.
- When replacing oil filters, check if any metal particles are affixed to the old filter. If any metal particles are found, contact your Komatsu distributor.
- Do not unpack a new replacement filter box until the moment it is used. Otherwise the quality may deteriorate on account of dust or contamination.
- Use of Komatsu genuine filter elements is strongly recommended.

RELATING TO ELECTRIC SYSTEM

- If the wiring gets wet or the insulation is damaged, there may likely be short circuit. That is very dangerous, since a defective electric parts often results in an erratic motion of the machine. Hence avoid to splash water on the electric accessories and repair damaged insulation.
- Inspection and maintenance works include checking the fan belt for tension and damage as well as the battery for electrolyte level.
- Never try to dismantle the electrical accessories installed on the machine or disassemble them.
- Never install any electric components other than those specified by Komatsu.
- When washing the machine, or when it rains, take care so that the electric accessories do not get splashed with water.
- External electro-magnetic interference may cause malfunction of the control system controller, so before installing a radio receiver or other wireless equipment, contact your Komatsu distributor.
- When the machine is operated on a seaside, take a good care of the electric accessories so that they do not get corroded.

OUTLINE OF HYDRAULIC EQUIPMENT

- The hydraulic components are hot during and right after operation. Moreover they are under high pressure while in operation. Take a good care when carrying out inspection or maintenance work for them under such circumstances.
- Inspection and maintenance works include checking the hydraulic system for oil level, replacement of filter elements and replacement of hydraulic oil.
- When disconnecting the high pressure hoses, check that there is no flaw on the O rings. Replace it with new one, if any.
- When the hydraulic oil filter elements or strainers are cleaned or replaced, or when any hydraulic component has been repaired or replaced, or when a hydraulic piping has been disconnected, bleeding air from the hydraulic system is required.

AIR-BLEEDING FROM HYDRAULIC CIRCUIT

When the hydraulic oil filter elements or strainers are cleaned or replaced, or when any hydraulic component has been repaired or replaced, or when a hydraulic piping has been disconnected, bleed air from the hydraulic oil circuit.

JOB CONTENTS AND AIR-BLEEDING PROCESS

Item Contents of work	Air bleeding procedure						
	1	2	3	4	5	6	7
	Air bleeding in the pump	Starting engine	Air bleeding in the grizzly feeder motor	Air bleeding in the jaw crusher motor	Air bleeding in the travel motor	Air bleeding in the belt conveyor motor	Starting operation
•Replacement of hydraulic tank •Cleaning of strainer	○ →	○ →	○ →	○ →	○ →		○
•Replacement of return filter element		○ →					○
•Replacement and repair of pump •Removal of suction piping	○ →	○ →	○ →	○ →	○ →		○
•Replacement and repair of control valve		○ →	○ →	○ →	○ →		○
•Replacement of grizzly feeder motor •Removal of grizzly feeder motor piping		○ →	○ →				○
•Replacement of jaw crusher motor •Removal of jaw crusher motor piping		○ →		○ →			○
•Replacement of travel motor •Removal of travel motor piping		○ →			○ →		○
•Replacement of belt conveyor motor •Removal of belt conveyor motor piping		○ →				○ →	○

WEAR PARTS

WEAR PARTS LIST

The parts in parentheses are to be replaced at the same time.

Item of Filter	Part No.	Part Name	Q'ty	Replacement Interval
Engine oil filter	6136-51-1231	Cartridge	1	Every 250 hours of operation
Hydraulic oil filter	208-60-61180 (07000-05210)	Element (O-ring)	1 (1)	Every 500 hours of operation
Fuel filter	600-311-8293	Cartridge	1	Every 500 hours of operation
Hydraulic oil tank breather	20Y-60-21440	Element	1	Every 500 hours of operation
corrosion resistor	600-411-1151	Cartridge	1	Every 1000 hours of operation
Air cleaner	6125-81-7032	Inner element assembly	1	-
	600-181-4300	Outer element assembly	1	
Line filter	207-60-61250 (07002-13634)	Strainer (O-ring)	2 (2)	-

JAW CRUSHER RELATED PARTS

No.	Part Name	Part No.	Q'ty	Unit Weight [kg (lb)]
1	Protector	8295-70-5090	1	81.0 (179)
2	Protector bolt	01010-82075	4	-
3	Protector nut	01580-12016	4	-
4	Protector washer	01643-32060	4	-
5	Wedge (for fixed jaw plate)	8295-70-5060	2	3.2 (7.06)
6	Wedge bolt (for fixed jaw plate)	8295-70-5040	2	-
7	Wedge nut (for fixed jaw plate)	01580-12419	2	-
8	Wedge cap nut (for fixed jaw plate)	8295-70-5210	2	-
9	Wedge washer (for fixed jaw plate on frame side)	8295-70-5180	2	-
10	Wedge washer (for fixed jaw plate on nut side)	8295-70-5170	2	-
11	Wedge spring (for fixed jaw plate)	8248-70-6030	2	-
12	Dust cover	8248-70-5540	1	-
13	Fixed jaw plate	8295-70-5050	1	1515.0 (3341)
14	Swing jaw plate	8295-70-5070	1	1110.0 (2448)
15	Cheek plate (upper right)	8295-70-5120	1	106.0 (234)
16	Cheek plate (lower right)	8295-70-5140	1	72.0 (159)
17	Cheek plate (upper left)	8295-70-5110	1	106.0 (234)
18	Cheek plate (lower left)	8295-70-5130	1	72.0 (159)
19	Cheek plate bolt	8295-70-5190	6	-
20	Cheek plate nut	01580-12419	12	-
21	Cheek plate washer	8248-70-5980	6	-
22	Wedge (for swing jaw plate)	8295-70-5080	1	76.0 (168)
23	Wedge bolt (for swing jaw plate)	8295-70-5250	4	-
24	wedge nut (for swing jaw plate)	01580-12419	4	-
25	Wedge cap nut (for swing jaw plate)	8295-70-5210	4	-
26	Wedge washer (for swing jaw plate on frame side)	8295-70-5180	4	-
27	Wedge washer (for swing jaw plate on nut side)	8295-70-5330	4	-
28	Wedge spring (for swing jaw plate)	8248-70-6030	4	-
29	Toggle seat (for swing jaw side)	8295-70-5160	1	38.6 (85)
30	Toggle seat (for toggle block side)	8295-70-5170	1	39.0 (86)
31	Toggle seat holder	8248-70-5530	4	-
32	Togle seat holder bolt	01010-81655	8	-
33	Toggle seat holder washer	01643-31645	8	-
34	Toggle plate	8295-70-5150	1	136.0 (300)
35	V-belt (8V-1900 x 6 pcs)	8295-70-1611	1	14.5 (31.97)

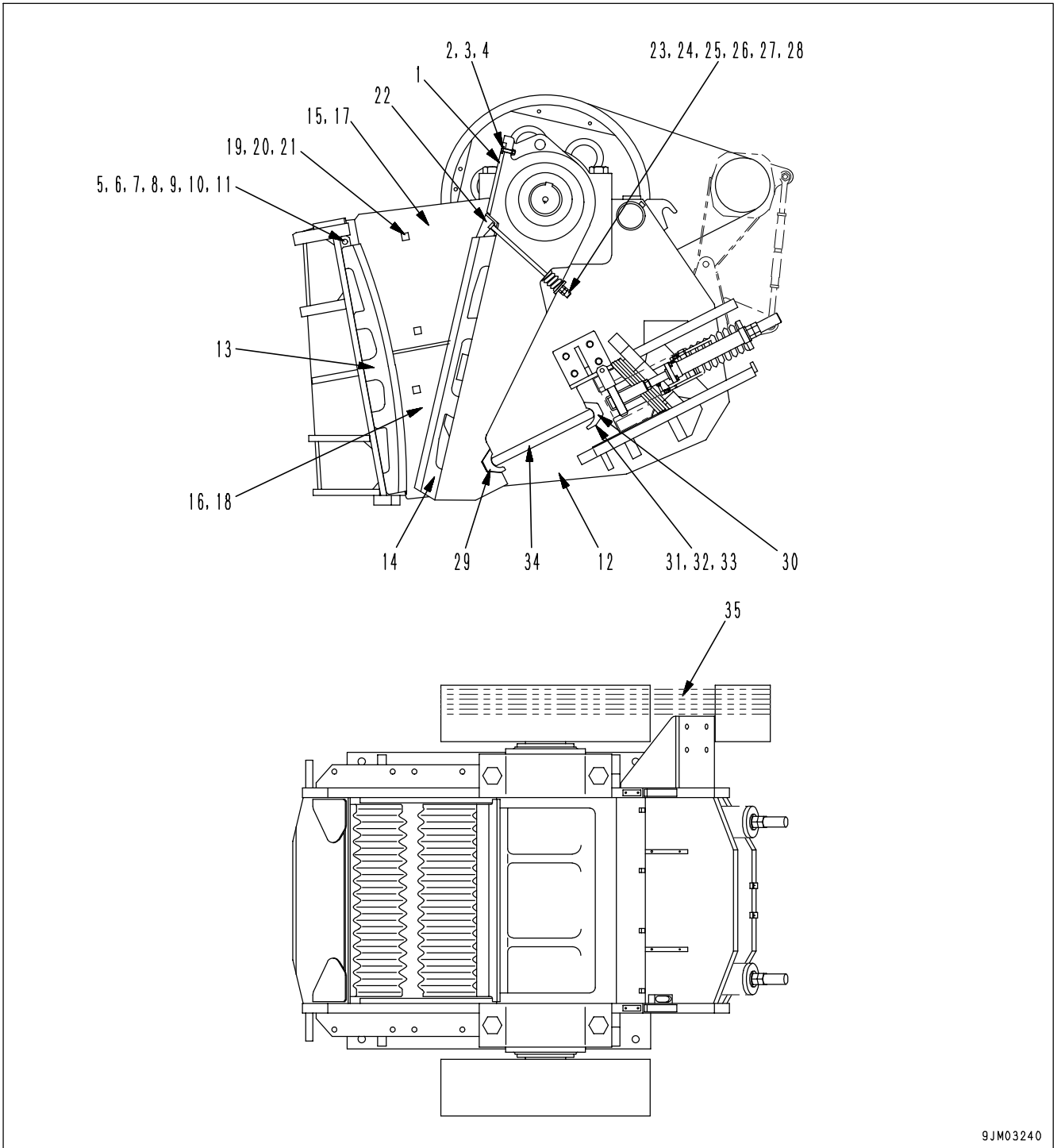

9JM03240

PRIMARY CONVEYOR RELATED PARTS

No.	Part Name		Part No.	Q'ty	Unit Weight [kg (lb)]
1	Conveyor belt		Not to be supplied as single parts. See following specifications.		
2	Bearing unit		8253-75-1770	1	10.0 (22.05)
3	Bearing		8253-75-1920	1	8.20 (18.08)
4	Rubber		8295-75-2431	2	2.90 (6.39)
5	Belt cleaner	Assembly	8295-75-2750	1	17.0 (37.49)
5-1		Cushion	8294-75-2160	9	-
5-2		Chip	8294-75-2180	9	-
6	Carrier roller		8295-75-2610	24	6.90 (15.21)
7	Guide roller		8248-75-3180	8	1.50 (3.31)
8	Return roller (outer)		8295-75-2630	2	23.2 (51)
9	Guide plate		8295-75-2871	1	17.2 (37.93)
10	Return roller (inner)		8295-75-2620	3	18.6 (41.04)
11	Rubber		8295-75-2411	2	2.85 (6.28)
12	Scraper rubber		8295-75-2780	1	0.75 (1.65)
13	Rubber		8295-75-2391	2	2.95 (6.50)
14	Rubber		8295-75-2381	2	3.95 (8.71)
15	Impact bar (under crusher)		8295-75-2730	9	7.00 (15.44)
16	Impact bar (below shuter)		8295-75-2740	9	3.05 (6.73)
17	Rubber		8295-75-2461	1	2.05 (4.52)
18	Bearing		8242-75-2580	2	0.80 (1.76)

Belt specification

Condition	Head pulley diameter	φ400	φ400	φ400	φ350
	Tail pulley diameter	φ320	φ340	φ300	φ280
Size	Width	1050 mm (3 ft 5 in)			
	Length of endless	22460 mm (73 ft 8 in)			
Belt strength		500kg/cm			
No. of ply		2	2	2	2
Core material		Polyester	Nylon	Polyester	Nylon
Cover rubber thickness (front x rear)		6.0 mm x 3.0 mm (0.236 in x 0.118 in)	6.0 mm x 3.0 mm (0.236 in x 0.118 in)	6.0 mm x 3.0 mm (0.236 in x 0.118 in)	6.0 mm x 3.0 mm (0.236 in x 0.118 in)
Overall thickness (for reference only)		11.8 mm (0.5 in)	11.9 mm (0.5 in)	12.1 mm (0.5 in)	12.0 mm (0.5 in)

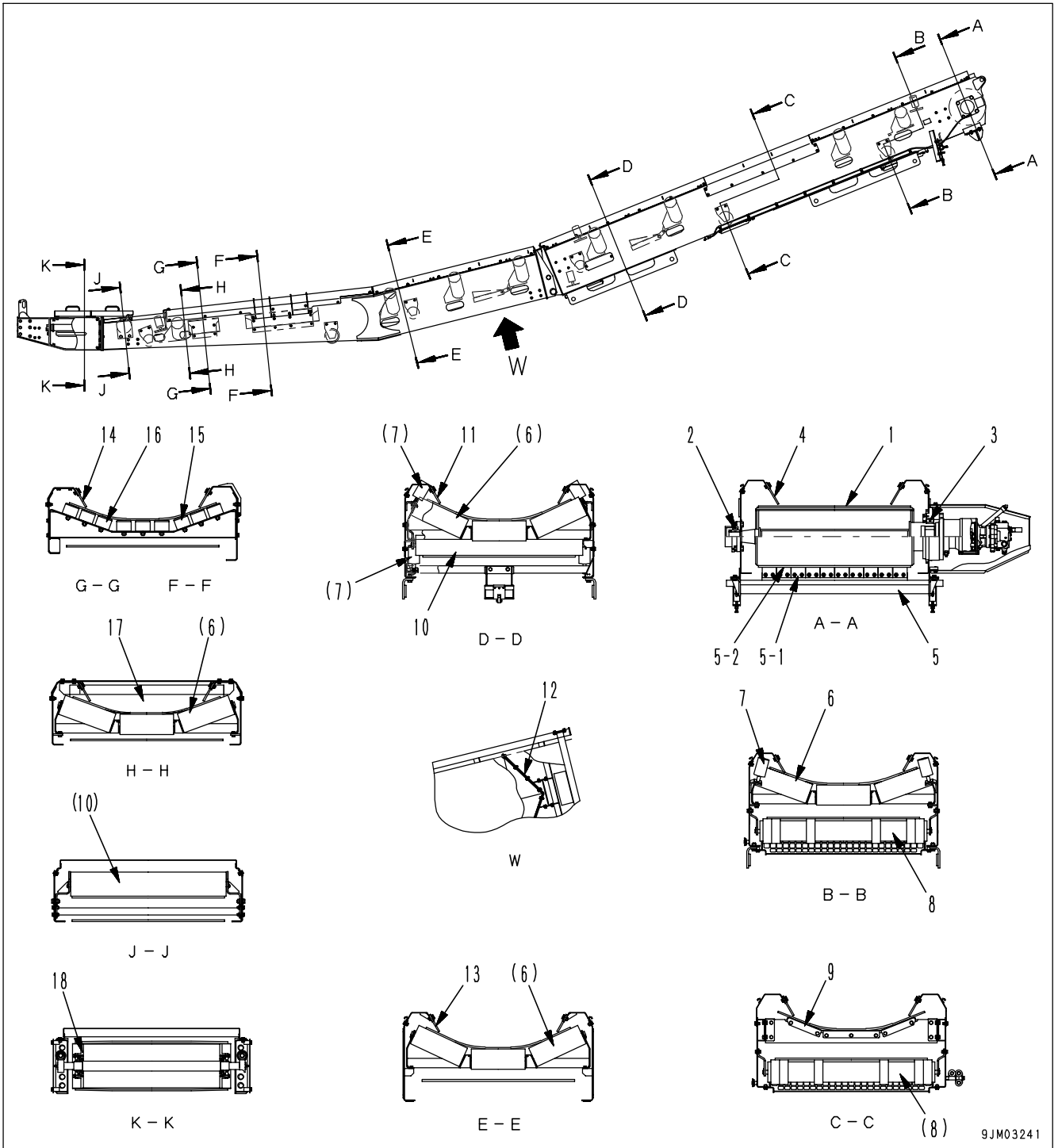

USE OF FUEL, COOLANT AND LUBRICANTS ACCORDING TO AMBIENT TEMPERATURE

RESERVOIR	KIND OF FLUID	AMBIENT TEMPERATURE								
		-22 -30	-4 -20	14 -10	32 0	50 10	68 20	86 30	104°F 40°C	
Engine oil pan	Engine oil					SAE 30				
					SAE 10W					
				SAE 10W-30						
				SAE 15W-40						
Damper case										
Jaw crusher motor bearing case										
Final drive case (each)		SAE 30								
Grizzly feeder vibrator case										
Belt conveyor motor machinery case										
Hydraulic system		SAE 10W								
	SAE 10W-30									
	SAE 15W-40									
Fuel tank	Diesel fuel			ASTM D975 No.2						
			*1							
Grease fitting	Grease	NLGI No.2								
Cooling system	Water	Add antifreeze								

*1: ASTM D975 No. 1

		Engine oil pan	Dumper case	Jaw crusher motor bearing case	Final drive case (each on right and left)	Grizzly feeder vibrator case
Specified oil amount (Bypass filter installed)	liters	38 (41)	0.75	8.1	10	15
	US gal	10.04 (10.83)	0.20	2.14	2.64	3.96
Refill oil amount (Bypass filter installed)	liter	34 (37)	-	8.1	9.5	15
	US gal	8.98 (9.78)	-	2.14	2.51	3.96

		Conveyor motor machinery case	Hydraulic oil system	Fuel tank	Cooling system
Specified oil amount	liters	2.5	370	605	43.9
	US gal	0.66	97.75	159.84	11.6
Refill oil amount	liters	2.5	270	-	-
	US gal	0.66	71.93	-	-

REMARK

- When fuel sulphur content is less than 0.5%, change oil in the oil pan according to the periodic maintenance hours described in this manual.
Change oil according to the following table if fuel sulfur content is above 0.5%.
- When starting the engine with an atmospheric temperature of lower than 0°C (32°F), be sure to use engine oil of SAE10W, SAE10W-30 and SAE15W-40, even though the atmospheric temperature goes up to 10°C (50° F) more or less during the day.
- Use API classification CD as engine oil and if API classification CC, reduce the engine oil change interval to half.
- There is no problem if single grade oil is mixed with multigrade oil (SAE10W-30, 15W-40), but be sure to add single grade oil that matches the temperature range in the table.
- We recommend Komatsu genuine oil which has been specifically formulated and approved for use in engine and hydraulic work equipment applications.

Specified capacity: Total amount of oil including oil for components and oil in piping.

Refill capacity: Amount of oil needed to refill system during normal inspection and maintenance.

ASTM: American Society of Testing and Material

SAE: Society of Automotive Engineers

API: American Petroleum Institute

Fuel sulfur content	Engine oil change interval
0.5 to 1.0%	1/2 of regular interval
Above 1.0%	1/4 of regular interval

No.	Supplier	Engine Oil [CD or CE] SAE10W, 30, 40 10W30, 15W40 (The 15W40 oil marked * is CE.)	Gear Oil [GL-4 or GL-5] SAE80, 90, 140	Grease [Lithium-Base] NLGI No.2	Anti-freeze Coolant [Ethylene Glycol Base] Permanent Type
1	KOMATSU	EO10-CD EO30-CD EO10-30CD EO15-40CD	GO90 GO140	G2-LI G2-LI-S	AF-ACL AF-PTL AF-PT(Winter, one season type)
2	AGIP	Diesel sigma S super dieselmulti- grade *Sigma turbo	Rotra MP	GR MU/EP	-
3	AMOCO	*Amoco 300	Multi-purpose gear oil	PYKON premium grease	-
4	ARCO	*Arcofleet S3 plus	Arco HD gear oil	Litholine HEP 2 Arco EP moly D	-
5	BP	Vanellus C3	Gear oil EP Hypogear EP	Energrease LS-EP2	Antifreeze
6	CALTEX	*RPM delo 400 RPM delo 450	Universal thuban Universal thuban EP	Marfak all purpose 2 Ultra-duty grease 2	AF engine coolant
7	CASTROL	*Turbomax *RX super CRD	EP EPX Hypoy Hypoy B Hypoy C	MS3 Spheerol EPL2	Anti-freeze
8	CHEVRON	*Delo 400	Universal gear	Ultra-duty grease 2	-
9	CONOCO	*Fleet motor oil	Universal gear lubricant	Super-sta grease	-
10	ELF	Multiperformance 3C Performance 3C	-	Tranself EP Tranself EP type 2	Glacelf
11	EXXON (ESSO)	Essolube D3 *Essolube XD-3 *Essolube XD-3 Extra *Esso heavy duty Exxon heavy duty	Gear oil GP Gear oil GX	Beacon EP2	All season coolant
12	GULF	Super duty motor oil *Super duty plus	Multi-purpose gear lubricant	Gulfcrown EP2 Gulfcrown EP special	Antifeeze and coolant
13	MOBIL	Delvac 1300 *Delvac super 10W-30, 15W-40	Mobilube GX Mobilube HD	Mobilux EP2 Mobilgease 77 Mobilgrease special	-

No.	Supplier	Engine Oil [CD or CE] SAE10W, 30, 40 10W30, 15W40 (The 15W40 oil marked * is CE.)	Gear Oil [GL-4 or GL-5] SAE80, 90, 140	Grease [Lithium-Base] NLGI No.2	Anti-freeze Coolant [Ethylene Glycol Base] Permanent Type
14	PENNZOIL	*Supreme duty fleet motor oil	Multi-purpose 4092 Multi-purpose 4140	Multi-purpose white grease 705 707L White-bearing grease	Anti-freeze and summer coolant
15	PETROFIN A	FINA kappa TD	FINA potonic N FINA potonic NE	FINA marson EPL2	FINA tamidor
16	SHELL	Rimura X	Spirax EP Spirax heavy duty	Albania EP grease	-
17	SUN	-	Sunoco GL5 gear oil	Sunoco ultra prestige 2EP Sun prestige 742	Sunoco antifreeze and summer coolant
18	TEXACO	*Ursa super plus Ursa premium	Multigear	Multifak EP2 Starplex 2	Coda 2055 startex antifreeze coolant
19	TOTAL	Rubia S *Rubia X	Total EP Total Transmission TM	Multis EP2	Antigal/antifreeze
20	UNION	*Guardol	MP gear lube LS	Unoba EP	-
21	VEEDOL	*Turbostar *Diesel star MDC	Multigear Multigear B Multigear C	-	Antifreeze

STANDARD TIGHTENING TORQUES FOR BOLTS AND NUTS

REMARK

For tightening torque of the bolts used for the jaw crusher, see the section of "OPERATION (PAGE 3-33)".

CRUSHER ACCESSORY TOOLS

No.	Tool Name	Part No.	Q'ty	Remarks
	Tool assembly	8295-70-5700	1	
1	Wrench	8242-70-5C80	1	24 mm (for M16)
2	Wrench	8242-70-5C90	1	30 mm (for M20)
3	Wrench	8242-70-5D10	1	36 mm (for M24)
4	Wrench	8242-70-5D20	1	46 mm (for M30)
5	Wrench	8248-70-5730	2	65 mm (for M42)
6	Wrench	8248-70-5740	1	230 to 250 mm
7	Wrench	8242-70-5D70	1	6 mm
8	Spanner	8248-70-5750	1	95 mm (for M64)
9	Fixed jaw plate and cheek plate maintenance socket	8248-70-5770	1	M24 x 105L
10	Swing jaw plate maintenance socket	8295-70-5510	1	M24 x 320L
11	Ratchet handle	8242-70-5E30	1	500L
12	Extension pipe	8242-70-5E50	1	∅42.7 x 900L
13	Eyebolt	04530-11018	1	M10
14	Eyebolt	04530-11222	2	M12
15	Eyebolt	04530-12030	2	M20
16	Cheek plate maintenance hook	8285-70-5B60	1	∅36 x 760L
17	Swing jaw plate wedge handring shackle	8295-70-5911	2	SIZE 16
18	Clearance measurement gauge	8295-70-5570	1	55/100 mm
19	Clearance measurement gauge	8248-99-9392	1	150/200 mm
20	Swing jaw stopper	8248-70-5860	1	∅30 x 600L
21	Shim plate (t12)	8295-70-5940	7	
22	Shim plate (t12)	8295-70-5950	7	
23	Shim plate (t9)	8295-70-5960	4	
24	Shim plate (t9)	8295-70-5970	4	
25	Measure	8242-70-5F40	1	
26	Square timber for handring of wedge	8295-70-5720	2	45 x 45 x 250

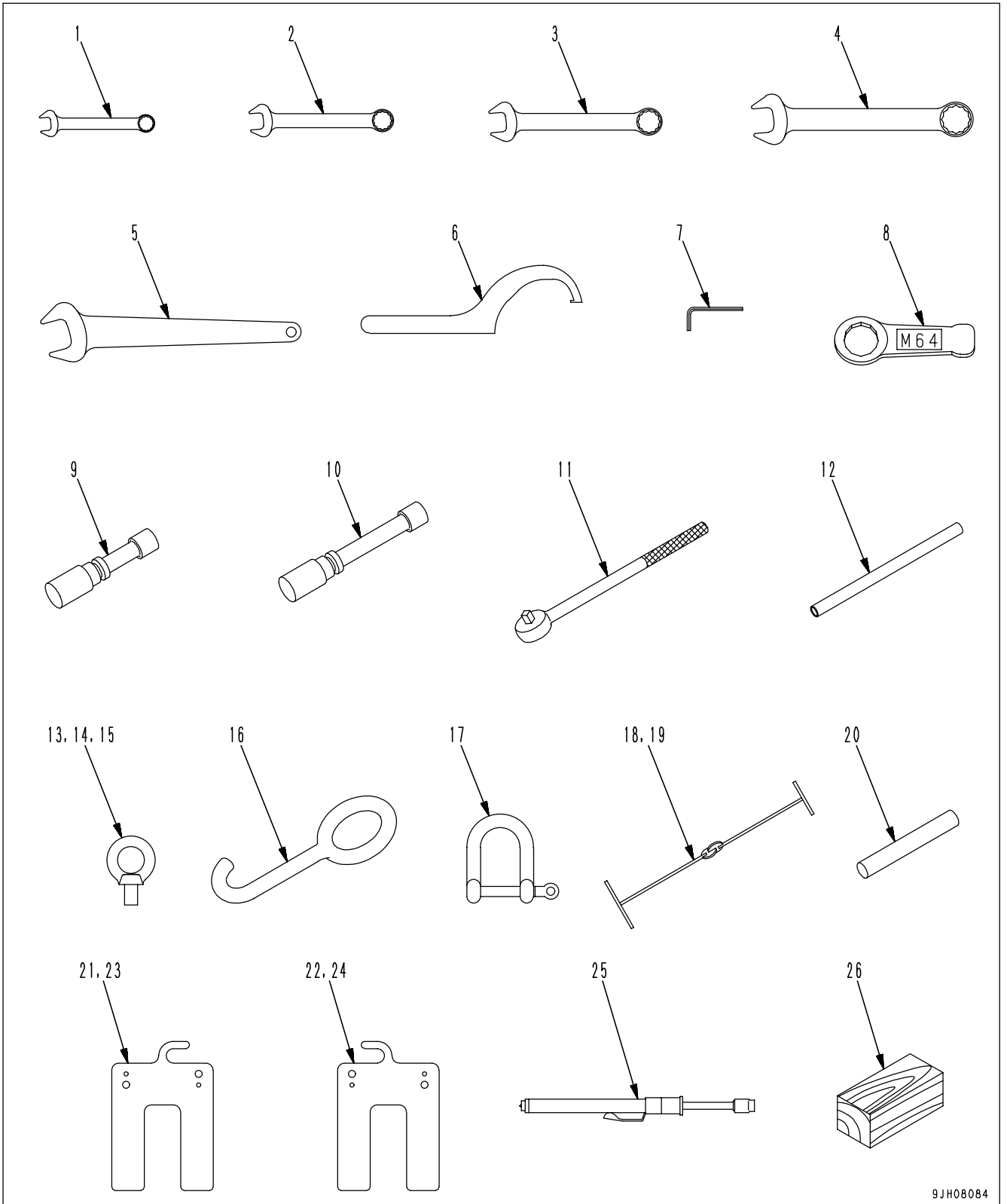

9JH08084

TORQUE LIST

NOTICE

When tightening a bolt through panels made of resin, they will be broken at the base, if an excessive tightening torque is applied to the bolt. Be careful not to exceed the right tightening torque.

Unless otherwise specified, tighten the metric nuts and bolts to the torque shown in the table below.

The tightening torque is determined by the width across the flats (b) of the nut and bolt.

If it is necessary to replace any nut or bolt, always use a Komatsu genuine part of the same size as the part that was replaced.

Thread diameter of bolt (a)(mm)	Width across flats (b)(mm)	Tightening torque					
		Target value			Service limit		
		N-m	kgf-m	lbft	N-m	kgf-m	lbft
6	10	13.2	1.35	9.8	11.8-14.7	1.2-1.5	8.7-10.8
8	13	31	3.2	23.1	27-34	2.8-3.5	20.3-25.3
10	17	66	6.7	48.5	59-74	6.0-7.5	43.4-54.2
12	19	113	11.5	83.2	98-123	10.0-12.5	72.3-90.4
14	22	177	18	130.2	157-196	16.0-20.0	115.7-144.7
16	24	279	28.5	206.1	245-309	25.0-31.5	180.8-227.8
18	27	382	39	282.1	343-425	35.0-43.5	253.2-314.6
20	30	549	56	405.0	490-608	50.0-62.0	361.7-448.4
22	32	745	76	549.7	662-829	67.5-84.5	488.2-611.2
24	36	927	94.5	683.5	824-1030	84.0-105.0	607.6-759.5
27	41	1320	135.0	976.5	1180-1470	120.0-150.0	868.0-1085.0
30	46	1720	175.0	1265.8	1520-1910	155.0-195.0	1121.1-1410.4
33	50	2210	225.0	1627.4	1960-2450	200.0-250.0	1446.6-1808.3
36	55	2750	280.0	2025.2	2450-3040	250.0-310.0	1808.3-2242.2
39	60	3280	335.0	2423.1	2890-3630	295.0-370.0	2133.7-2676.2

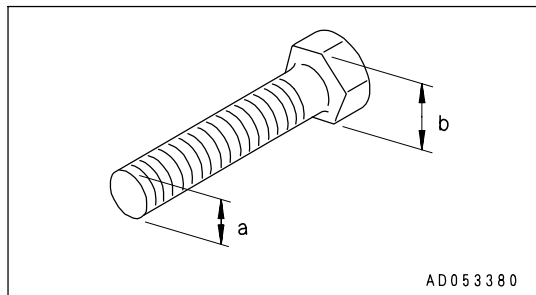

Apply the following table for Hydraulic Hose.

Thread diameter of bolt (a)(mm)	Width across flats (b)(mm)	Tightening torque					
		Target value			Service limit		
		N-m	kgf-m	lbft	N-m	kgf-m	lbft
10	14	14.7	1.5	10.8	12.7-16.7	1.3-1.7	9.4-12.3
14	19	29.4	3.0	21.7	27.5-39.2	2.8-4.0	20.3-28.9
18	24	78.5	8.0	57.3	58.8-98.1	6.0-10.0	43.4-72.3
22	27	117.7	12.0	86.8	88.3-137.3	9.0-14.0	65.1-101.3
24	32	147.1	15.0	108.5	117.7-176.5	12.0-18.0	86.8-130.2
30	36	215.7	22.0	159.1	176.5-245.2	18.0-25.0	130.2-180.8
33	41	255.0	26.0	188.1	215.7-284.4	22.0-29.0	159.1-209.8

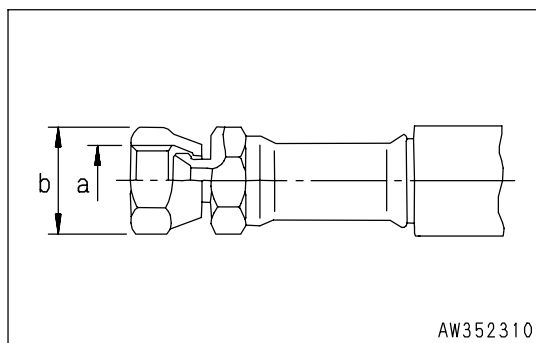

PERIODIC REPLACEMENT OF SAFETY CRITICAL PARTS

To ensure safety at all times when operating or driving the machine, the user of the machine must always carry out periodic maintenance. In addition, to further improve safety, the parts in the safety-critical parts list on the next page must also be replaced at the specified interval. These parts are particularly closely connected to safety and fire prevention, so please contact your Komatsu distributor to have them replaced.

Material quality of these parts can change as time passes and they are likely to wear out or deteriorate. However, it is difficult to determine the extent of wear or deterioration at the time of periodic maintenance. Hence, it is required to replace them with new ones regardless of their condition after a certain period of usage. This is important to ensure that these parts maintain their full performance at all times.

Furthermore, should anything abnormal be found on any of these parts, replace it with a new one even if the periodic replacement time for the part has not yet arrived.

If any of the hose clamps show deterioration like deformation or cracking, replace the clamps at the same time as the hoses.

Also perform the following checks with hydraulic hoses which need to be replaced periodically. Tighten all loose clamps and replace defective hoses, as required.

When replacing hoses, always replace O-rings, gaskets, and other such parts at the same time.

SAFETY CRITICAL PARTS

No	Periodic Replacement Part	Q'ty	Replacement Interval
1	Fuel hose (fuel tank - connector)	2	Every 2 years or every 4000 hours, whichever earlier.
2	Spill hose (nozzle - fuel tank)	1	
3	Spill hose (between nozzles)	2	
4	Fuel hose (fuel filter - fuel injection pump)	2	
5	fuel pump outlet hose (fuel pump - control valve)	2	
6	Work equipment hose (at crusher motor gate)	4	
7	Work equipment hose (feeder motor gate)	2	
8	Work equipment hose (primary conveyor belt motor gate)	2	
9	Main suction hose	1	
10	Gear pump suction hose	1	

MAINTENANCE SCHEDULE CHART

MAINTENANCE SCHEDULE CHART

INITIAL 250 HOURS MAINTENANCE (ONLY AFTER THE FIRST 250 HOURS)

Replacement fuel filter cartridge	4- 69
Change oil in engine oil pan, replace engine oil filter cartridge	4- 67
Change oil in grizzly feeder vibrator case	4- 75
Check engine valve clearance, adjust	4- 79

WHEN REQUIRED

Check, clean and replace air cleaner element	4- 25
Clean inside of cooling system	4- 28
Check and tighten track shoe bolt	4- 32
Check and adjust track tension	4- 33
Check and adjustment of jaw crusher	4- 36
Check and adjustment of primary belt conveyor	4- 57

CHECK BEFORE STARTING

EVERY 100 HOURS SERVICE

Greasing crusher bearing seat	4- 60
Drain water, sediment from fuel tank	4- 60
Greasing primary belt conveyor	4- 61

EVERY 250 HOURS SERVICE

Check level of battery electrolyte	4- 62
Check fan belt and alternator belt tension, adjust	4- 63
Check and adjustment of jaw crusher V-belt	4- 65
Check of oil level in crusher motor bearing case and adding oil	4- 66
Change oil in engine oil pan, replace engine oil filter cartridge	4- 67

EVERY 500 HOURS SERVICE

Replace fuel filter element	4- 69
Check oil level in final drive case, add oil	4- 70
Replace hydraulic filter element	4- 71
Clean and inspect radiator fins, oil cooler fins	4- 72
Replace hydraulic tank breather element	4- 73

EVERY 1000 HOURS SERVICE

Change of oil in crusher motor bearing case	4- 74
Change of oil in grizzly feeder vibrator case	4- 75
Change oil in damper case	4- 76
Check all tightening parts of turbocharger	4- 76
Check play of turbocharger	4- 76
Replace corrosion resistor cartridge	4- 77
Change of oil in conveyor motor machinery case	4- 78

EVERY 2000 HOURS SERVICE

Change oil in final drive case	4- 79
Check alternator, starting motor	4- 79
Check engine valve clearance, adjust	4- 79
Clean hydraulic tank strainer	4- 80
Clean engine breather	4- 80
Clean, check turbocharger	4- 80

EVERY 4000 HOURS SERVICE

Check water pump	4- 81
------------------------	-------

EVERY 5000 HOURS SERVICE

Change oil in hydraulic tank and clean strainer	4- 82
---	-------

SERVICE PROCEDURE

INITIAL 250 HOURS MAINTENANCE (ONLY AFTER THE FIRST 250 HOURS)

Carry out the following maintenance only for once after the initial 250 hours of operation.

- Replace fuel filter cartridge
- Replacement of oil in engine oil pan and engine oil filter cartridge
- Change of oil in grizzly feeder vibrator case
- Check engine valve clearance, adjust

For details of the method of replacing or maintaining, see EVERY 500 HOURS, EVERY 1000 HOURS and EVERY 2000 HOURS SERVICE.

WHEN REQUIRED

CHECK, CLEAN AND REPLACE AIR CLEANER ELEMENT

 **WARNING**

- If inspection, cleaning, or maintenance is carried out with the engine running, dirt will get into the engine and damage it. Always stop the engine before carrying out these operations.
- When using compressed air, there is danger that dirt may be blown around and cause serious injury. Always use protective glasses, dust mask, and other protective equipment.

CHECKING

If air cleaner clogging monitor (1) of the monitor panel flashes, clean the air cleaner element.

NOTICE

Do not clean the air cleaner element until the air cleaner clogging monitor on the monitor panel flashes.

If the element is cleaned frequently before the clogging monitor flashes, the air cleaner will not be able to fully demonstrate its performance, and the cleaning efficiency will be also lowered.

In addition, during the cleaning work, dirt stuck to the element will more likely fall on the side of the inner element.

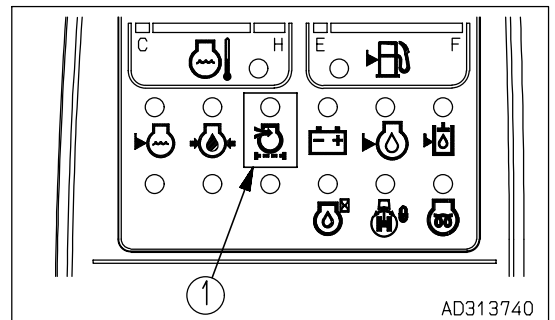

CLEANING OR REPLACING OUTER ELEMENT

1. Open the engine hood, loosen wing nut (2) and band (3), remove cover (4) and wing nut (5), and then take out element (6).
2. Clean the interior of the air cleaner body and cover (4).

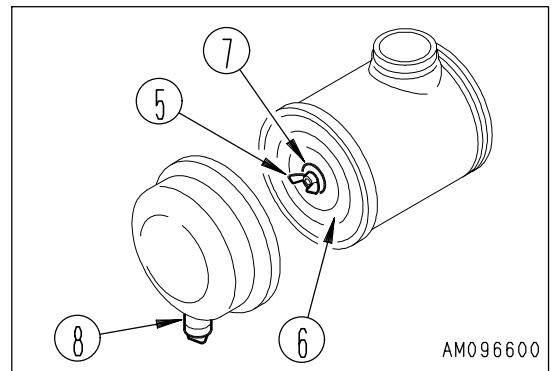
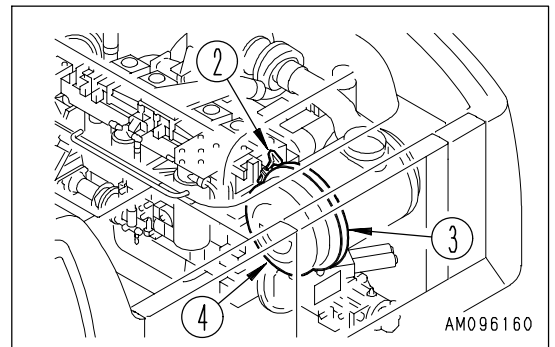

3. Blow dry compressed air 0.69 MPa (7 kgf/cm², 99.4 PSI) along folds from within element (6). Next blow it along folds from the outside, then blow it again from within.

- 1) Remove one seal from the element whenever the element has been cleaned.
 - 2) Replace the outer element if it has been cleaned 6 times repeatedly or used throughout a year. Replace the inner element at the same time.
 - 3) Replace both inner and outer elements when the air cleaner clogging monitor(1) flashes soon after installing the cleaned outer element even though it has not been cleaned 6 times.
 - 4) Check inner element mounting nuts for looseness and, if necessary, retighten.
 - 5) If seal washer (7) is found damaged or wing nut (5) is broken, replace them with new ones.
 - 6) Dismantle evacuator valve (8) and clean it with compressed air. Install it again after the cleaning.
4. If small holes or thinner parts are found on the element when it is checked by shining a light through it after cleaning, replace the element.

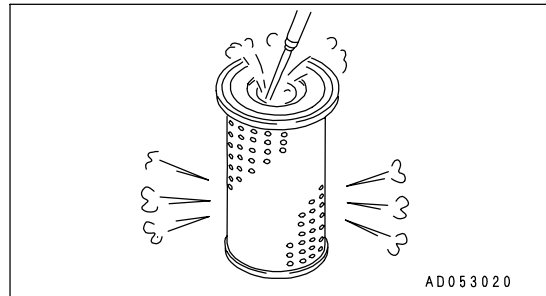

NOTICE

**When cleaning the element, do not hit it or beat it against something.
Do not use an element whose folds or gasket or seal are damaged.
Wrap unused element and store them in a dry place.**

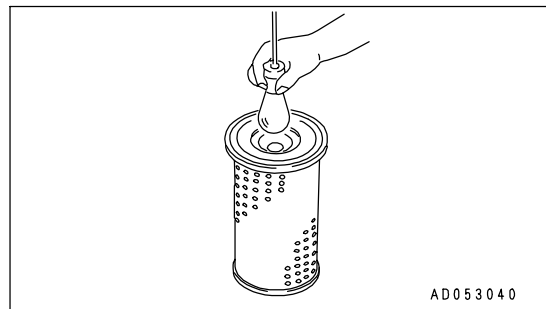

5. Remove the cloth or tape cover fitted in Step 1.
6. Install cleaned element (6) and fix it with wing nut (5).

REPLACING INNER ELEMENT

1. First remove the cover and the outer element, and then remove the inner element.
2. Cover the air connector side (outlet side) with a clean cloth or tape.
3. Clean the air cleaner body interior, then remove the cover from the air intake port in Step 2.
4. Fit a new inner element to the connector and tighten it with nuts.

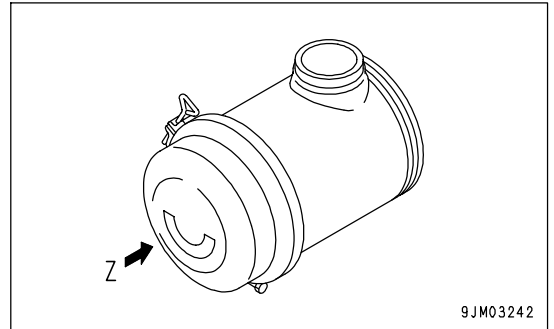

NOTICE

The inner element must not be used again even after cleaning. When replacing the outer element, replace the inner element at the same time.

5. Set the outer element in position and secure it with the wing nut.
6. Dismantle evacuator valve (8) and clean it with compressed air. Install it again after the cleaning.

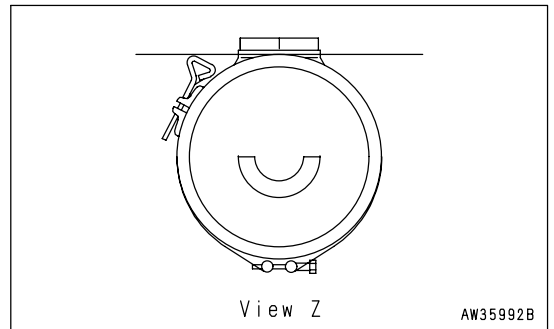

REMARK

When fixing wing bolt (2), make sure that the wing bolt head does not protrude from the top of cover (4) so that it will not interfere with the engine hood.

CLEAN INSIDE OF COOLING SYSTEM

 **WARNING**

- The engine cooling water is still at high temperature right after the engine is stopped and the radiator interior is pressurized. If the radiator cap is loosened under such conditions, the hot water spurts out, causing a serious burn. Wait until the temperature cools down and turn the cap slowly to release the internal pressure.
- Start the engine for cleaning. When leaving the machine, while the engine is running, set the travel lever safety lock to the LOCK position.
- For starting the engine, see the sections of "CHECK BEFORE STARTING ENGINE (PAGE 3-33)" and "STARTING ENGINE (PAGE 3-49)" in OPERATION of Operation in this manual.
- If the engine is run without the undercover, there is the danger that you may touch the rotating fan.
When the engine is running, never get close to the rear of the machine.

Clean the inside of the cooling system, change the coolant and replace the corrosion resistor according to the table below.

Kind of Antifreeze	Cleaning of Cooling System and Replacement	Replacement of Corrosion Resistor (if equipped)
Super Coolant AF-ACL Antifreeze (Anti-corrosive and all season type)	Every two years (every other year and in fall) or 4000 hours of operation whichever comes earlier	Every 1000hours of operation plus when cleaning interior of cooling system and when replacing antifreeze

Stop the machine on level ground when cleaning or changing the coolant. Super Coolant (AF-ACL) has both antifreezing effect and anticorrosive effect. The mixing ratio depends on an ambient temperature. It should be minimum 30% in cubic ratio to obtain anticorrosive effect. When deciding the ratio of antifreeze to water, check the lowest temperature in the past, and decide from the mixing rate table given below. It is actually better to estimate a temperature about 10°C (18°F) lower when deciding the mixing rate.

Mixing rate of water and antifreeze

Lowest ambient temperature	°C	-10	-15	-20	-25	-30
	°F	14	5	-4	-13	-22
Amount of antifreeze	liter	13.2	15.8	18.0	20.2	21.9
	US gal	3.49	4.17	4.76	5.34	5.79
Amount of cooling water	liter	30.7	28.1	25.9	23.7	21.9
	US gal	8.11	7.42	6.84	6.26	5.79

**WARNING**

Antifreeze is flammable, so keep it away from flame.

Antifreeze is toxic. When removing the drain plug, be careful not to get water containing antifreeze on you. If it gets in your eyes, flush your eyes with large amount of fresh water and see a doctor at once.

Use city water for the coolant.

If river water, well water or other such water supply must be used, contact your Komatsu distributor.

We recommend use of an antifreeze density gauge to control the mixing proportions.

- Prepare a container of over 44 liter (11.62 US gal) capacity for receiving the mixture of antifreeze and cooling water.
1. Stop the engine and close the valve (1) of corrosion resistor cartridge.
 2. Turn radiator cap (2) slowly to remove it.

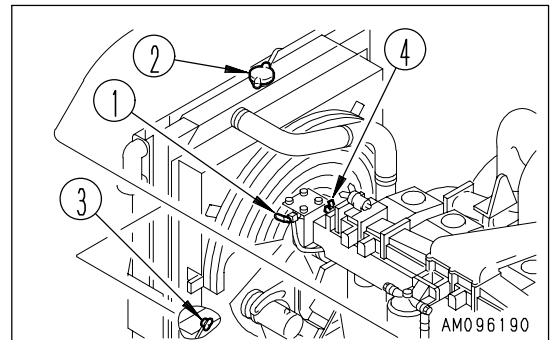

3. Take out a ladder (1) for maintenance works stored under the primary conveyor belt.

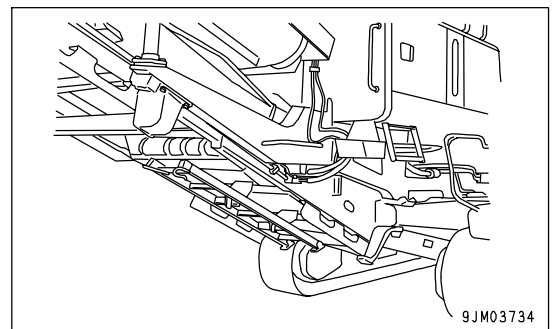

4. Hook the top of the ladder to the piping provided below the door at the left side of the machine.

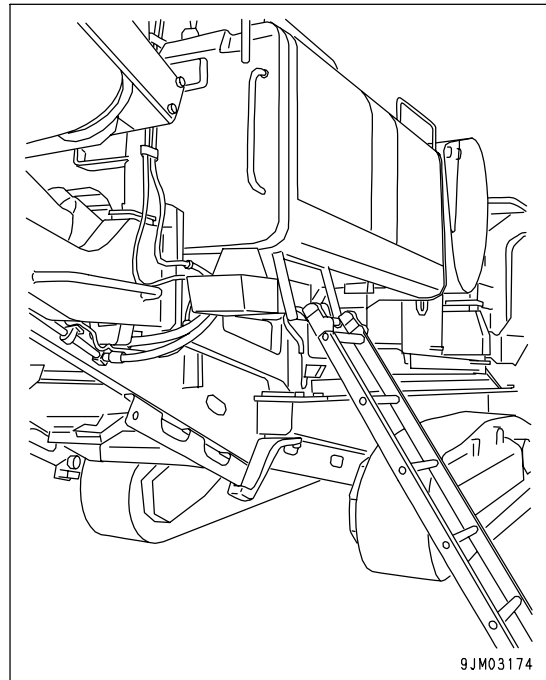

5. Open the door located on the left side at the rear of the machine.
6. Remove inspection cover (5) on the radiator undercover, and place the outlet of a draining extension hose in the coolant and antifreeze receiving container.
7. Open drain valve (3) to drain the coolant.
8. Close drain valve (3) after drainage, and fill the radiator with tap water.

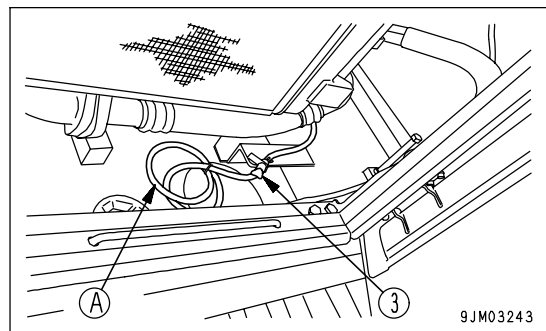

- When the radiator is completely filled, start the engine and keep it running at low idling.
9. Open drain valve (3) and clean the radiator with running water for ten minutes, keeping the engine at low idling.
- While cleaning the radiator with running water, try to adjust cleaning water input and output so that the radiator is kept full at all time. Keep a close watch on the water supply hose during supply lest it should come off the radiator water cap.

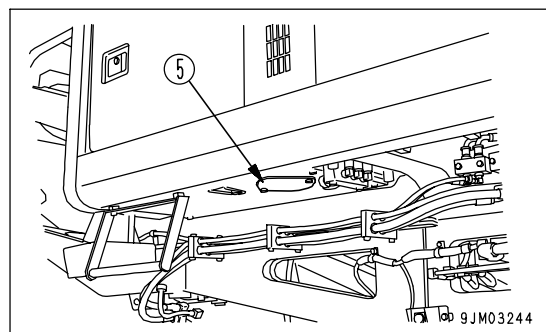

10. Stop the engine after the cleaning work.
- Stop supplying water and close drain valve (3).
11. After drainage, clean the interior with detergent.
- For the use of detergent, follow the instructions for detergent to be used.
12. After drainage, open drain valve (3) to drain all the water, then close it and fill the radiator with tap water almost up to the radiator cap.
 13. When water is filled up to the radiator cap, open drain valve (3) and continue to clean the radiator with running water until clean water comes out, keeping the engine at low idling.
- While cleaning the engine with running water, try to balance water supply and drainage to keep the radiator full of cleaning water at all time.
14. When clean water begins to flow out, stop the engine and close the drain valve.
 15. Replace the corrosion resistor and then open valve (1).
- For the replacement of the corrosion resistor, see the section of "REPLACE CORROSION RESISTOR CARTRIDGE (PAGE 4-77)".

16. Tuck away the draining extension hose on the undercover below the radiator, then fix inspection cover (5).
17. Open air bleeding valve (4) and pour antifreeze and tap water through the filler port up to the filler opening. Close air bleeding valve, when water overflows from the filler port.
18. Keep the engine at high idling for five minutes and at low idling for another five minutes to bleed air from the cooling system. (At that time, keep the filler port open)
19. Drain cooling water in the subtank, clean the interior, and fill it with fresh cooling water up to the medium level between the FULL and LOW marks.

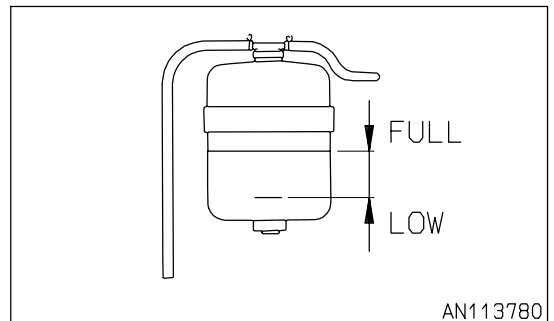
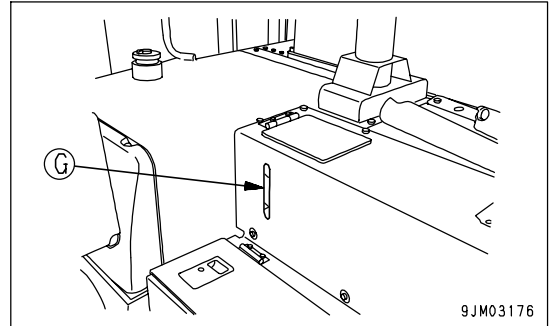

20. Stop the engine and wait for about three minutes. Then supply tap water up to the filler port and screw in the cap.
21. Store the ladder for maintenance work under the primary belt conveyor.

CHECK AND TIGHTEN TRACK SHOE BOLT

Track shoes may be broken, if they are used with loosened shoe bolts (1). Hence whenever a loosened bolt is found, be sure to retighten it.

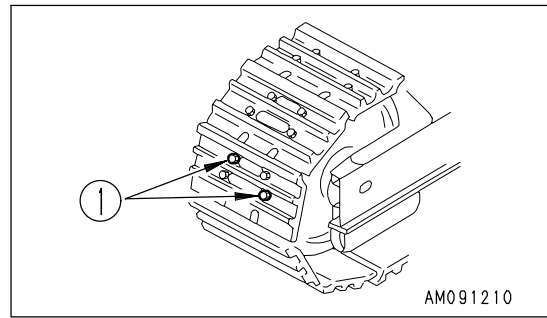

METHOD OF TIGHTENING

1. First tighten the shoe bolts to the tightening torque of $392 \pm 39.2\text{N}\cdot\text{m}$ ($40 \pm 4\text{kgf}\cdot\text{m}$, $289.3 \pm 28.9\text{lbf}\cdot\text{ft}$) and confirm that nuts (A) and (B) are in close contact with contact surface (a) of track link (C).
2. After checking, further tighten to the tightening torque of $120^\circ \pm 10^\circ$.

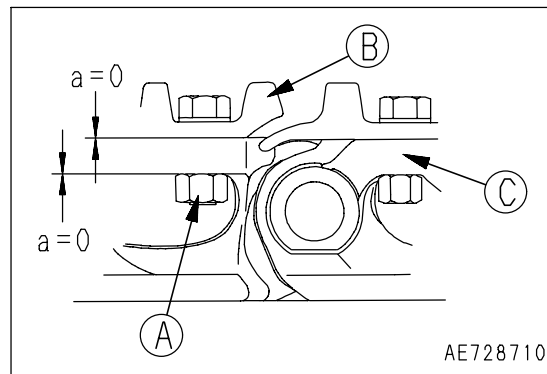

ORDER FOR TIGHTENING

- Tighten the bolts in the order as illustrated in the figure at right. After tightening, confirm that nut (A) and shoe plate (B) are in close contact with contact surface (a) of track link (C).

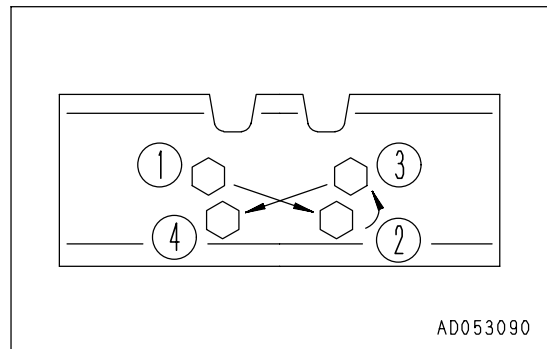

CHECK AND ADJUST TRACK TENSION

 **WARNING**

Let this job be carried out by two workers in pair. One of the two will serve as an operator and the other as a serviceman. The operator travels the machine at a signal from the serviceman and must be ready to stop it any moment. Inspection and tightening works of the track shoe assembly are to be carried out with the machine at a raised position. It is extremely dangerous to let it fall by accident, so never move the machine, while an inspection is going on.

The wear of pins and bushings on the undercarriage will vary with the working conditions and types of soil. It is thus necessary to continually inspect the track tension so as to maintain the standard tension. Carry out the check and adjustment under the same conditions as when operating (on jobsites where the track becomes clogged with mud, measure with the track clogged with mud). The standard clearance of A between the track frame lower face and track shoe upper face is 331 ± 20 mm (13.0 ± 0.8 in). The measurement method is as explained below.

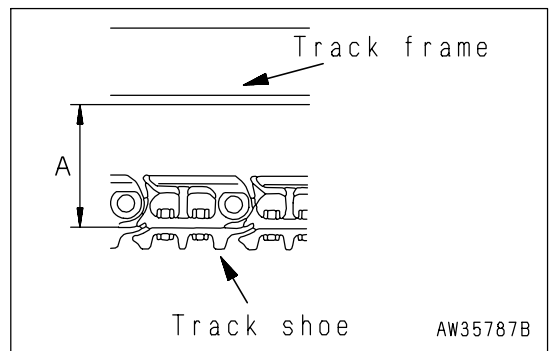

1. Place a wooden block of 100 mm (3.9 in) in height on the flat ground. Back the machine up to climb and rest on the block at the sprocket.
2. Measure the dimension from the track frame bottom surface to the top of the track shoe at the midpoint between the sprocket and the third (center) track roller.

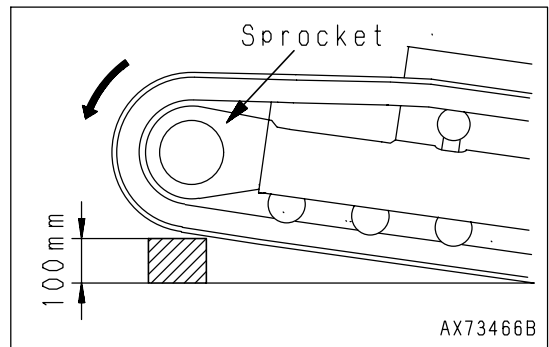

If the track tension is not at the standard value, adjust it in the following manner.

ADJUSTMENT

! WARNING

Since grease may spurt out due to the internal high pressure, do not loosen plug (1) by more than one turn.

Do not loosen any other parts than plug (1) at that time. Furthermore do not turn your face and body toward plug (1).

If the track shoe assembly may not be loosened following the procedures shown here, consult the Komatsu distributor in your territory.

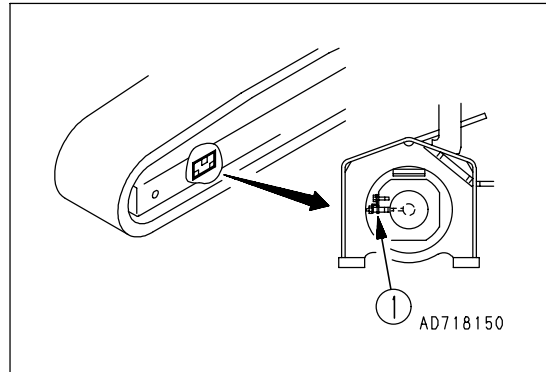

WHEN INCREASING TENSION

! WARNING

Prepare a grease gun.

1. Inject grease through grease fitting (2), using a grease gun.
2. Move the machine back and forth a few times for a distance of 5 m (16 ft 5 in) in order to confirm that the track shoe tension is correct, and then stop the engine.
3. Check the track tension again, and if the tension is not correct, adjust it again.
4. Continue to pump in grease until dimension S becomes zero (0). If the tension is still loose, the pin and bushing are excessively worn, so they must be either turned or replaced. Please contact your Komatsu distributor for repairs.

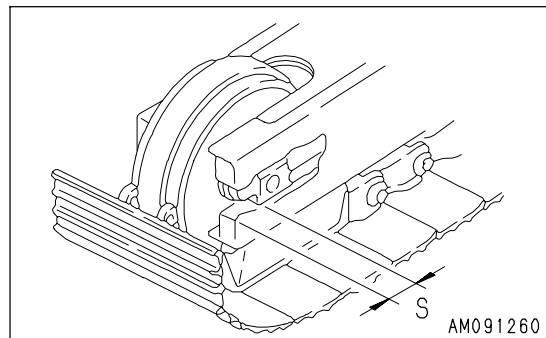
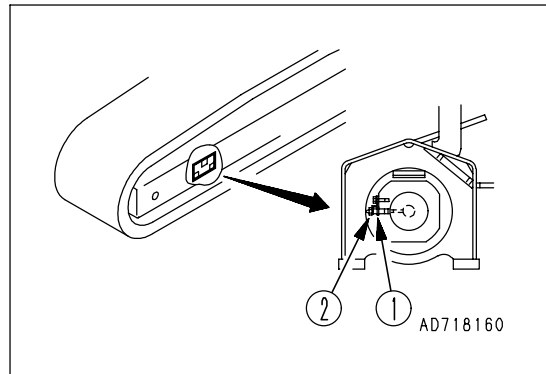

WHEN LOOSENING TENSION

**WARNING**

It is extremely dangerous to release the grease by any method except the procedure given below.
If track tension is not relieved by this procedure, contact your Komatsu distributor for repairs.

1. Loosen plug (1) gradually to release the grease.
2. When loosening plug (1), turn it a maximum of one turn.
3. If the grease does not come out smoothly, move the machine forwards and backwards a short distance.
4. Tighten plug (1).
5. Move the machine back and forth to confirm the track shoe tension is correct.
6. Check the track tension again, and if the tension is not correct, adjust it again.

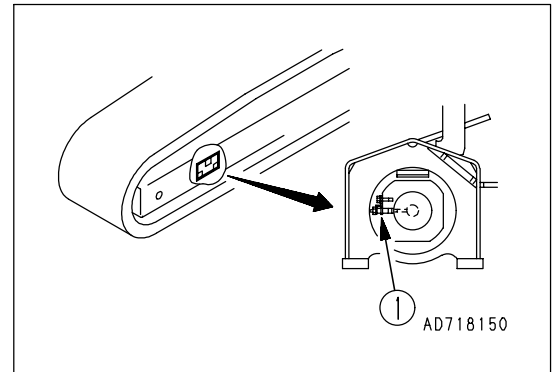

CHECK AND ADJUSTMENT OF JAW CRUSHER

CHECK AND ADJUSTMENT OF OUTLET CLEARANCE

CHECK OF OUTLET CLEARANCE

The outlet clearance (A) (opening side) indicates the distance from the tip of the fixed jaw plate and the bottom of the swing jaw plate, when the crusher outlet is most widely open. (In other words, when a portion of the flywheel painted red matches a portion of the flywheel cover painted red, as illustrated in the figure above)

Measurement is taken at three points, j.e. at both ends and at the center, and the lowest value is adopted as the representative one.

This measurement is made using a measuring rod.

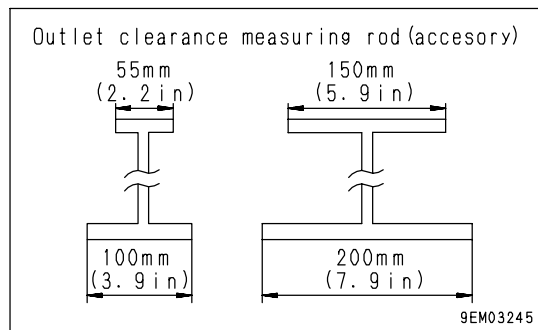
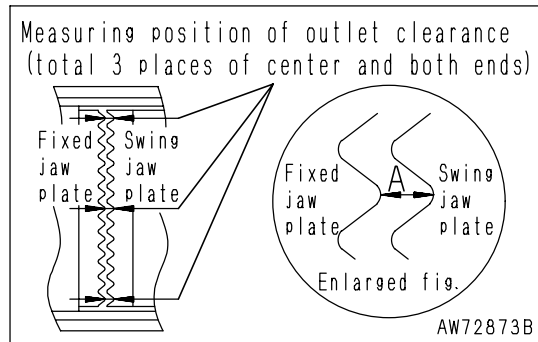

Below shown is the relation between the shim plate thickness (t) and outlet clearance, when both fixed and swing jaw plates are brand new.

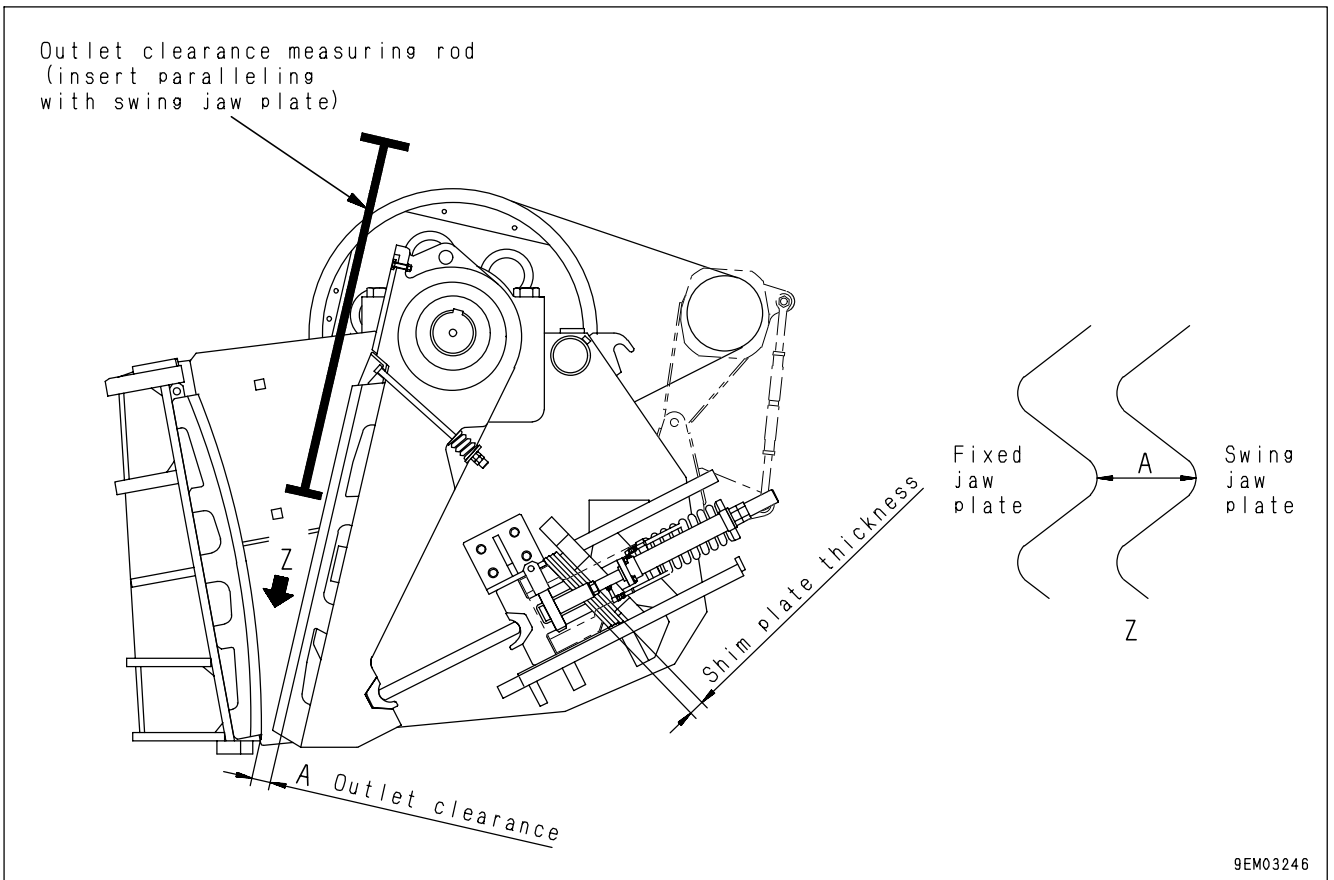

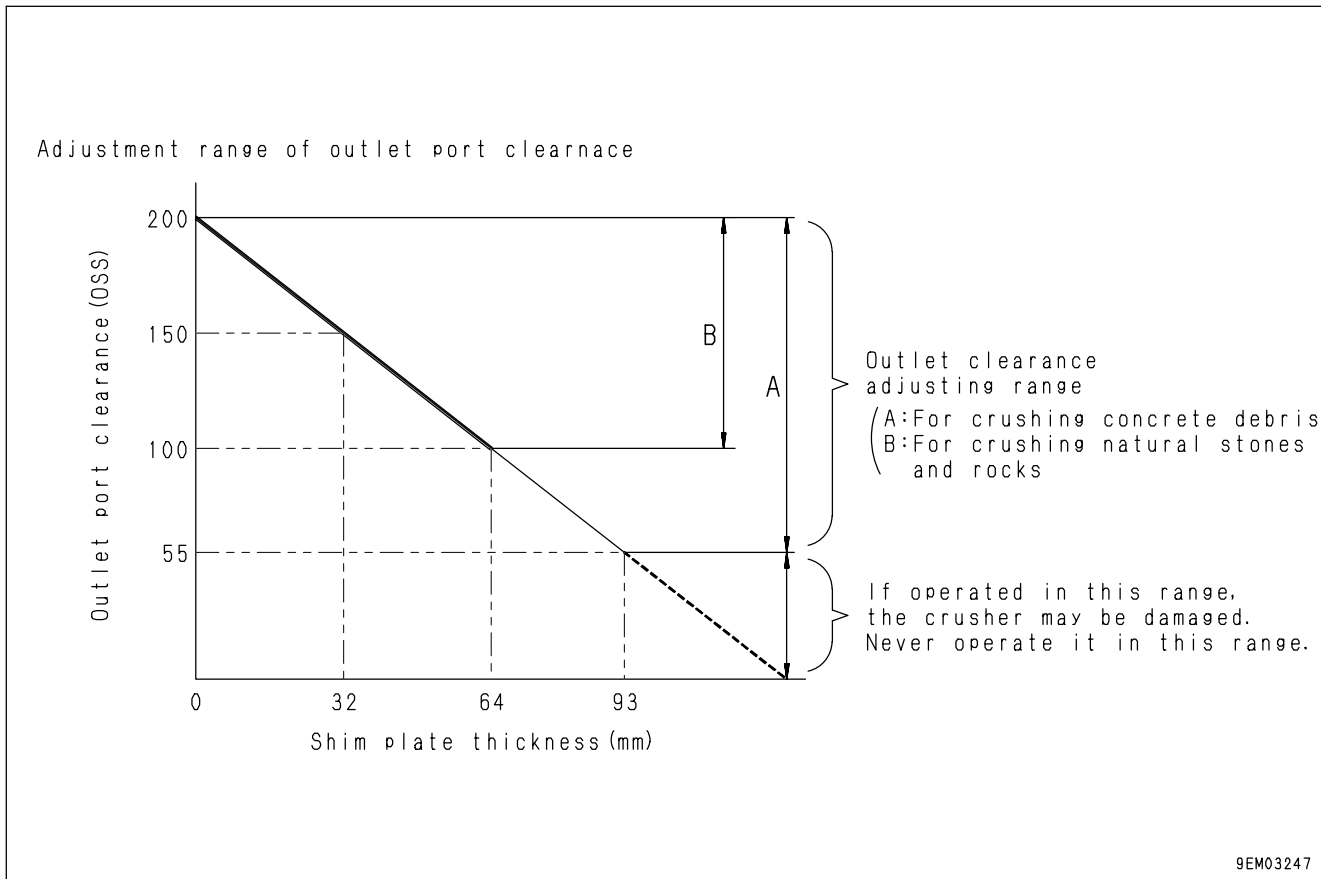

Attached plate
 t= 6 (4 plates)
 t= 9 (4 plates)
 t= 12 (16 plates)

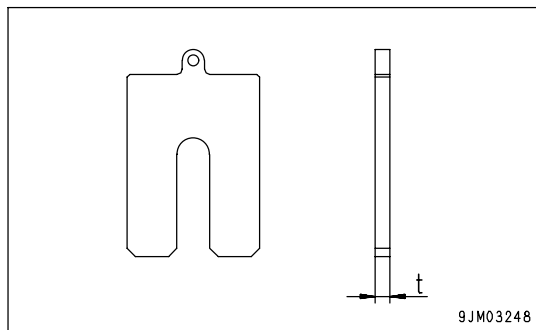

OUTLET CLEARANCE ADJUSTING METHOD

! WARNING

- Start the engine. For adjusting the outlet clearance, set the travel lever safety lock to the LOCK position without fail.
- Be sure to attach a warning tag to the starting switch in the control box.
- For starting the engine, see the sections of "CHECK BEFORE STARTING ENGINE (PAGE 3-33)" and "STARTING ENGINE (PAGE 3-49)" in Operation of OPERATION in this manual.

Determine the flywheel position through an inching operation before adjusting the outlet clearance so that both red painted portions of the flywheel and the cover match with each other.

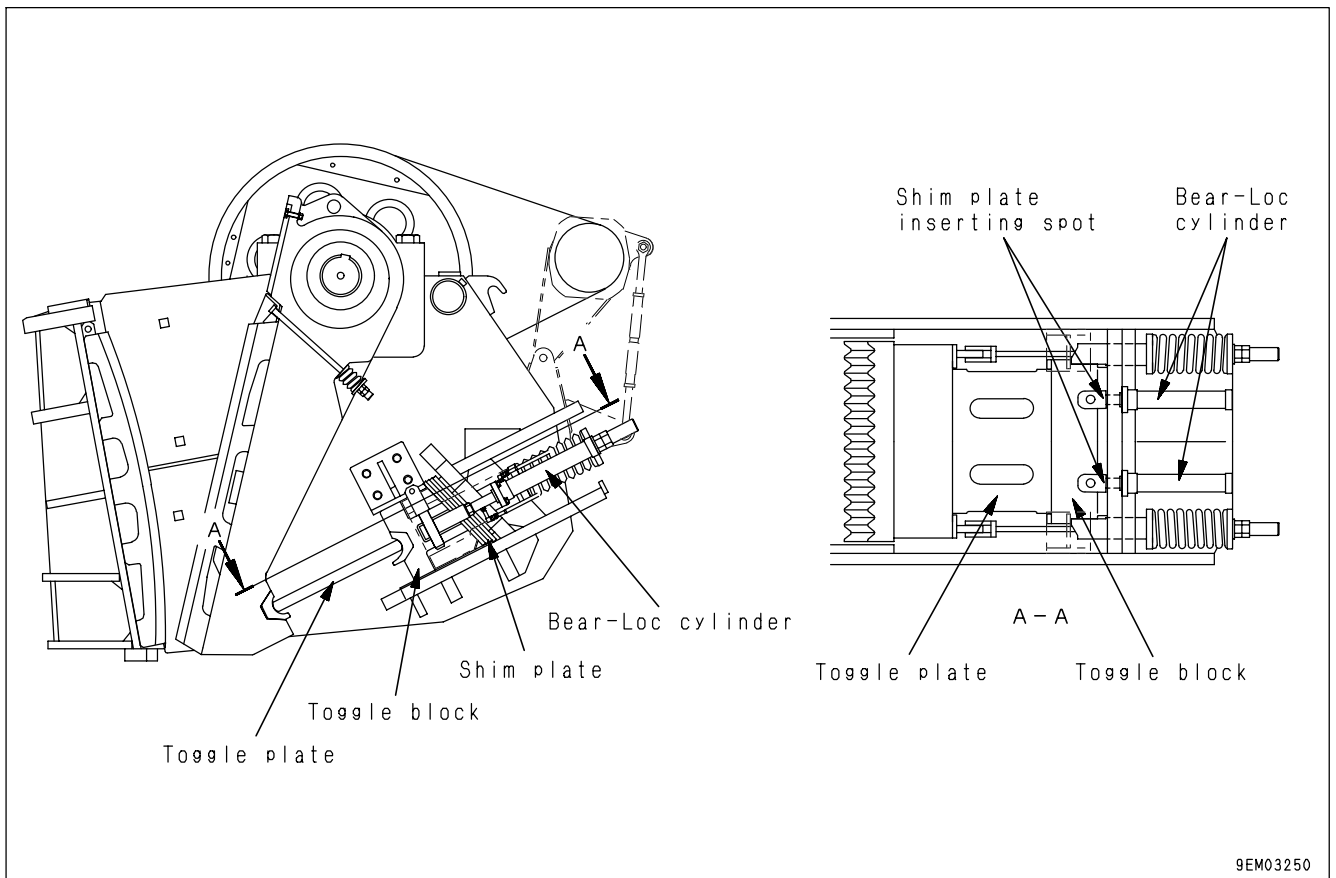
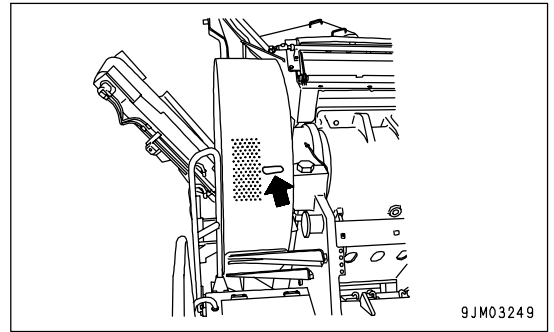

CAUTION

- The outlet clearance is set at 55 mm (2.2 in) (O.S.S.) when the machine is shipped out from the factory. Adjust it to a desired clearance according to debris to be crushed.
A set of shim plates, e.g. 7 plates of 12t and one plate of 9t, are inserted on each side. (Shim plates other than those above are kept in the tool box)
- O.S.S.means the widest clearance at the jaw crusher outlet.

1. Start the engine.
2. Set operation mode selector switch (2) to the "INSPECTION" position.
3. Attach a warning tag to the engine starting switch to announce to those concerned that an outlet clearance adjusting work is going on.
4. Check that there is nothing left in the crusher chamber, standing on the step provided on the side of the crusher and looking into the crusher chamber.
(Should small stones or debris be left in the crusher chamber, crush and discharge them, making the chamber empty)
5. Depress jaw crusher inching switch (3) in the upper control box, and match both red painted portions of the flywheel and flywheel cover through an inching operation.
6. Depress outlet clearance reduction switch (4) in the upper control box, and push the toggle block forward to the extent that the shim plates can be pulled out.
7. Change the overall thickness to a desired outlet clearance by adjusting the number of shim plates.

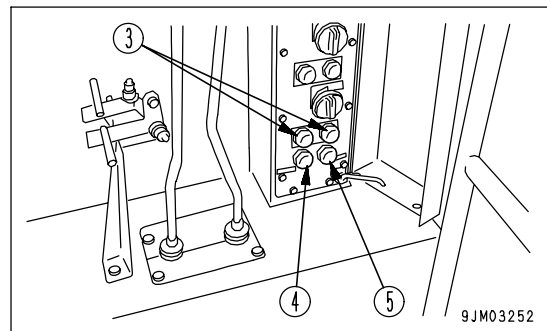
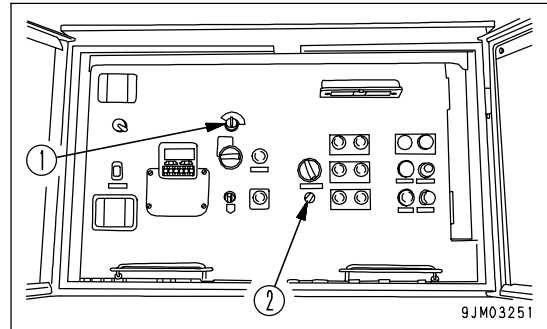

CAUTION

Adjust the number of shim plates so that they have the same thickness on both sides.

8. Depress outlet clearance expansion switch (5), and pull back the toggle block.
9. Measure the crusher outlet clearance.

REMARK

When taking the measure of the outlet clearance for setting it to any of O.S.S. 55 mm (2.2 in), 100 mm (3.9 in), 150 mm (5.9 in) and 200 mm (7.9 in), use the outlet clearance measurement gauges in the accessory parts. An effective measurement can be achieved. (The measurement gauges are stored inside the right wheel cover as illustrated at right)

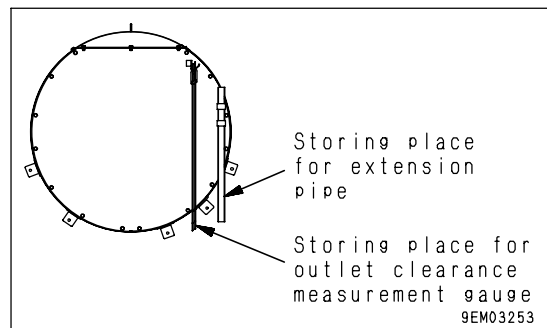

10. Store shim plates, which are not used, inside the wheel covers on both sides as illustrated in the figure at right. Thus the adjustment of the outlet clearance has been finished. The machine is now ready for starting works.

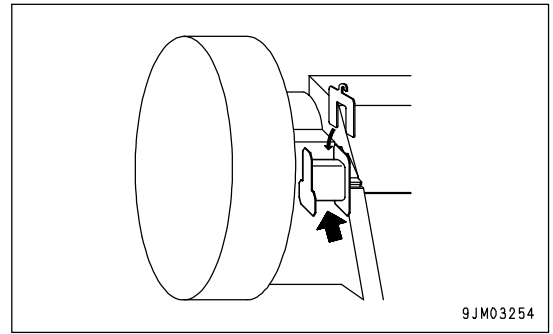

CONFIRMATION OF LOCKING FORCE AFTER STARTING WORK

CAUTION

- After adjusting the clearance at the outlet of the crusher jaw, be sure to carry out a trial operation under the trial conditions of engine revolution at low idling and crusher revolution at MIN and confirm that there is no abnormal noise from around the toggle block.
- When inserting shim plates, confirm the total number and thickness of the right and left shims to ensure the identical shim plate thickness on both sides. Should the shim plate thickness differ between the right and the left sides, there would be a critical damage to the crusher main body.

For some time after an operation is started with load, the locking force may be reduced on account of insufficient contact of the shims or fine foreign objects caught between the shims. When adjustment was made of the clearance at the outlet of the crusher due to the wear on the swing jaw plate and fixed jaw plate, tighten the shim plates (toggle block) every 30 minutes of operation until no backlash is confirmed.

Checking method

Hit the shim plates and the toggle block pins with a hammer to see if there is any backlash.

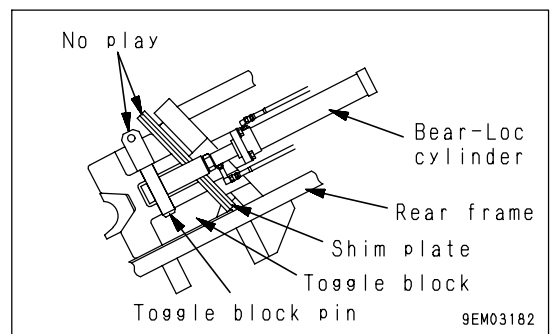

REMARK

If the backlash can be settled by no means, remove all the shims once by pushing the toggle block to the extreme front end, following the same procedure for the jaw crusher outlet clearance adjustment, and then blow them with an air or water gun to remove foreign objects.

CHECK OF WEAR ON MAJOR WEARING PARTS

JAW PLATE



- If the machine is used continuously with the crusher chamber excessively charged, premature partial wear will develop on the tips of jaw plates.
- If a work is continued with the partially worn jaw plates, rocks may not be discharged smoothly, eventually resulting in damages on the jaw plates on account of the worsened partial wear.
Replace the partially worn jaw plates with new ones.
- If jaw plates are used beyond their wear limit, a serious damage will be inflicted on the jaw crusher main body itself.

Hatched area : Area of virtual wear

If the bottom tips of fixed and swing jaw plates have been worn off and reached the wear limit as illustrated in the figure at right, either reverse or replace them, as the case may be.

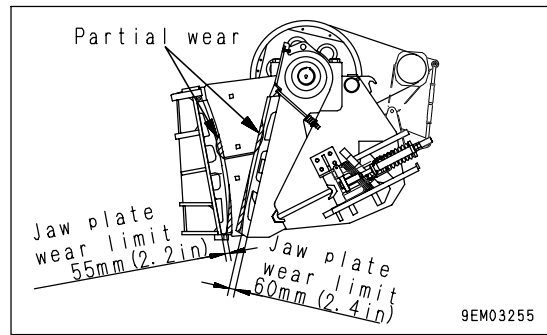

CHEEK PLATE

If the residual dimension reaches approx. 15 mm (0.6 in) [wear amount 15 mm (0.6 in)] on the upper end and approx. 10 mm (0.4 in) [wear amount 20 mm (0.8 in)] on the lower end, proceed with the replacement.

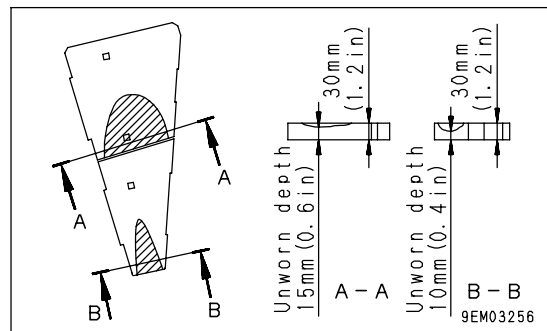

PROTECTOR

When the residual dimension reaches approx. 10 mm (0.4 in) [wear amount 12 mm (0.5 in)], proceed with the replacement. If a partial wear develops on the protector, replace it, too.

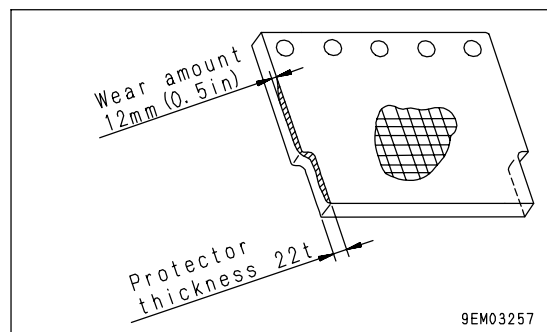

SWING JAW PLATE WEDGE

If the residual dimension reaches approx. 65 mm (2.6 in) [wear amount 30 mm (1.2 in)] on the lower end of the wedge, proceed with the replacement.

Replace a partially worn wedge, too.

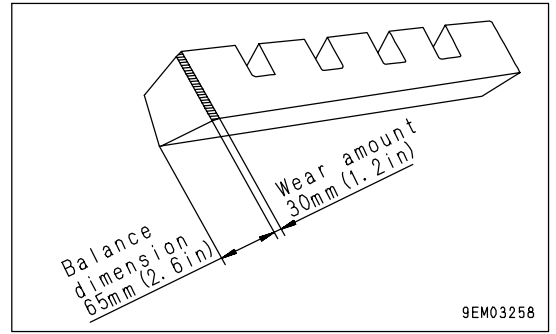

TOGGLE SEAT

If the wear dimension reaches approx. 5 mm (0.197 in), proceed with the replacement.

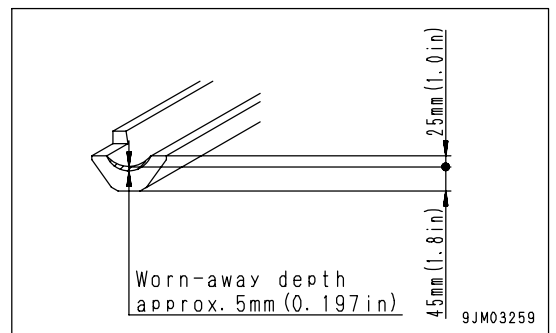

TOGGLE PLATE

If the wear dimension reaches approx. 5 mm (0.197 in) on one side, proceed with the replacement.

Replace a toggle seat that has been partially worn, as illustrated in the figure at right.

NOTICE

As an expedient measuring method, a wear amount on the toggle seat may be obtained by measuring the dimension between the toggle block and the swing jaw as installed.

If the above dimension reaches approx. 592 mm (23.3 in), dismantle the toggle seat and toggle plate, and measure their actual dimensions.

REMARK

- Use the above dimension as a guideline for the wear tolerance of the toggle seat and toggle plate.
- When replacing the toggle plate, replace the toggle plate dust cover, too.
- Even if any noise is heard from between the toggle seat and toggle plate, there should be no adverse effect on the machine, as far as the noise is generated by the toggle plate rolling on the toggle seat surface. If, on the other hand, it is a slapping noise, check if the tension spring set length is as specified.

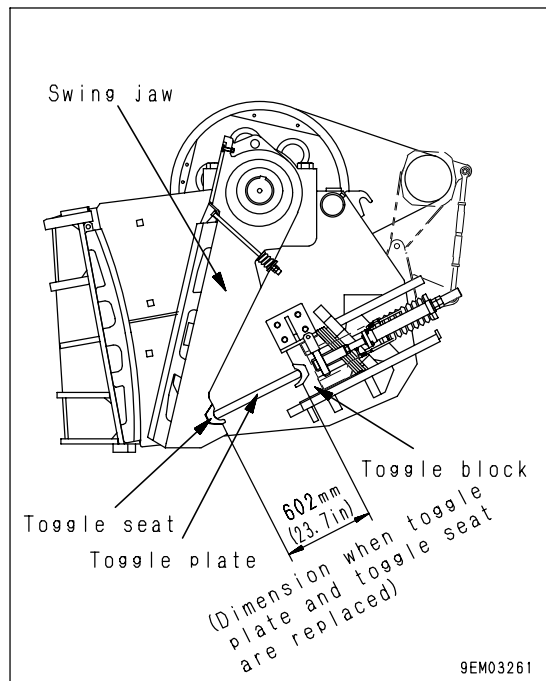
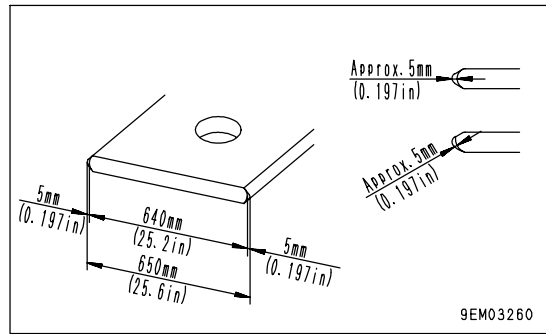

REPLACEMENT OF CHEEK PLATE

1. Take a special tool for hanging the cheek plate (Accessory Tool No. 16) out of the tool box.
2. Remove the cheek plate upper guard, using this special tool.
[Cheek plate upper guard weight: 31.4 kg (69 lb)]

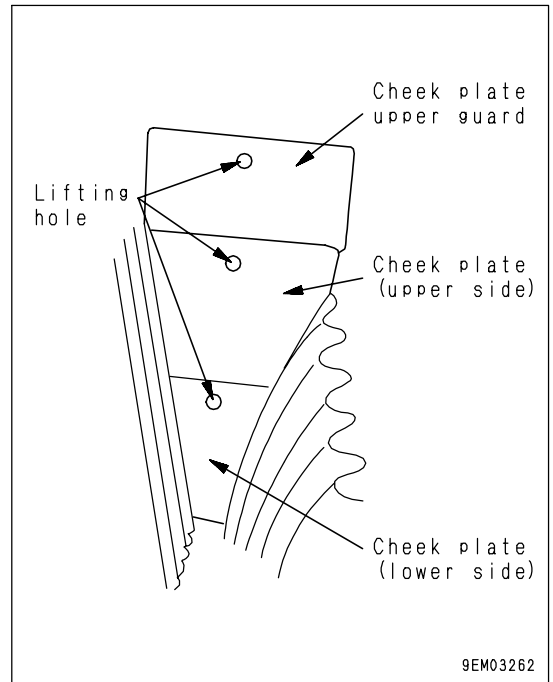

3. Remove soils, sand, etc. from the hanging hole of the upper cheek plate with compressed air or a wire brush, then lift up the upper cheek plate with the special tool.
[Upper cheek plate weight: 106.0 kg (234 lb)]
4. Remove soils, sand, etc. from the hanging hole of the lower cheek plate with compressed air or a wire brush, then lift up the lower cheek plate with the special tool.
[lower cheek plate weight: 72.0 kg (159 lb)]

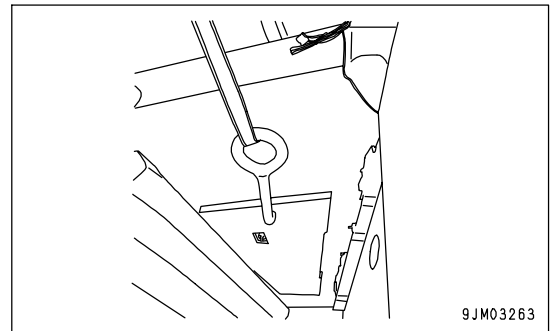

5. After removing all the cheek plates, completely remove the soil and sand from the cheek plate fitting surfaces (front, rear, right and left).
In particular, remove the soil and sand clogging both sides of the fixed jaw.

6. Insert new cheek plates in order from the underside along the fixed jaw and a guide of the side frame.
7. Tighten the bolts securing the cheek plates and cheek plate upper guard.
 - (1) For cheek plate: M24 x 3 bolts (on one side)
 - (2) For cheek plate upper guard: M24 x 4 bolts (on one side)

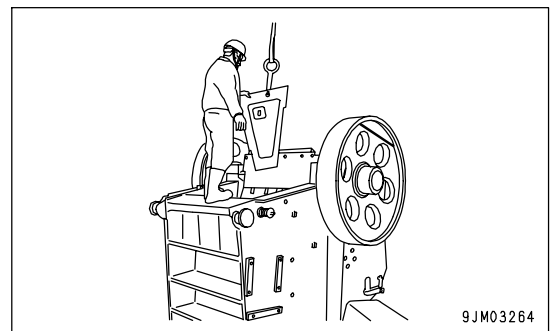

REVERSAL OR REPLACEMENT OF FIXED JAW PLATE

**CAUTION**

After dismantling the fixed jaw plate, completely remove soils, sand, etc. from the fixed jaw fitting surfaces (front frame and mount stopper upper surface). Unless removed completely, they may cause a backlash on the fixed jaw plate.

If the clearance is not even on the right and left sides, there will be a slippage from the swing jaw plate tip, which likely leads to premature wear or partial wear on the jaw plates.

1. Dismantle the cheek plates, referring to the section dealing with the cheek plate replacement.
2. Remove the fixed jaw plate wedge bolts and fixed jaw wedge lock.

Tools to use

- (1) Extension socket: Accessory Tool No. 9
- (2) Ratchet handle: Accessory Tool no. 11
- (3) Extension pipe: accessory Tool No. 12

3. Lift up the fixed jaw plate with a wire rope.
 - When reversing the fixed jaw plate, lower it on to a block once. Then hook a wire rope on the other side to lift it up and insert it into the crusher frame.
 - When replacing the worn fixed jaw plate, lower it on to a block once. Then lift up a new fixed jaw plate with a wire rope and insert it into the crusher frame.

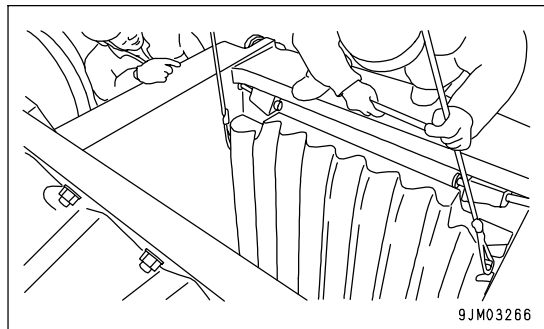
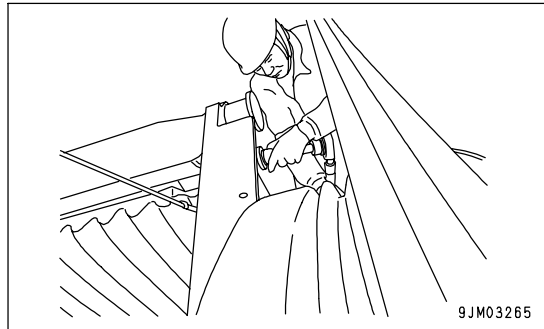

4. Take measurements of the clearance on both sides of fixed jaw plate, and position the fixed jaw plate and the crusher frame so that both centers are aligned.
5. Insert a sleeper, e.g. tie (or equivalent) between the fixed jaw plate and swing jaw plate.

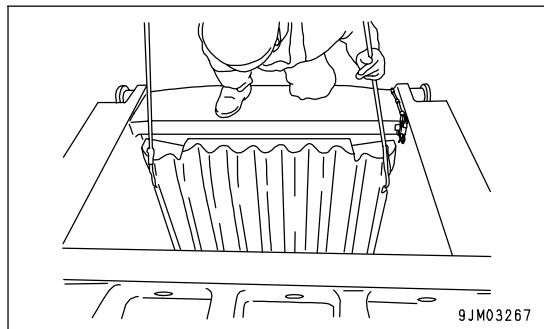

6. Push out the swing jaw plate with a hydraulic ram to press the fixed jaw plate against the front frame. For this work, refer to the section dealing with adjustment of the crusher outlet clearance.

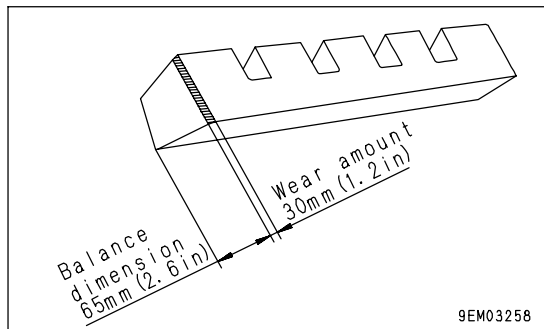

7. Secure the fixed jaw plate wedge and fixed jaw plate wedge bolts.

Set the length (A) of the fixed jaw plate wedge bolt spring at 100 mm (3.9 in).

8. Install the cheek plates.

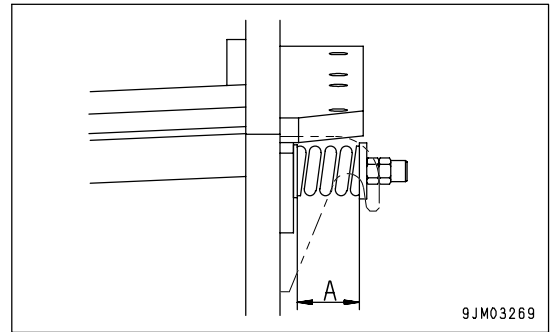

REVERSAL OR REPLACEMENT OF SWING JAW PLATE

1. Remove rubber plate (1) fitted to swing jaw cover (A).

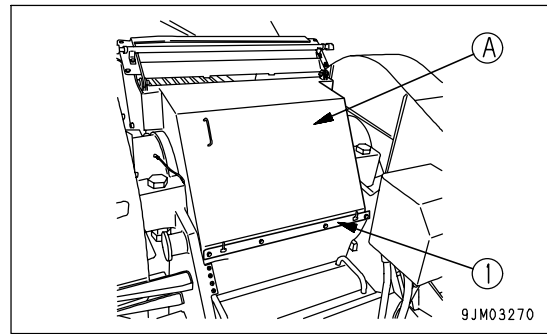

CAUTION

When pushing out the swing jaw plate wedge from behind the swing jaw, keep the two fixed jaw plate wedge center bolts as inserted to prevent the swing jaw plate wedge from falling off.

2. Loosen four fixed jaw plate wedge bolts (2) and remove the two at outside. Keep the two center bolts as inserted, after taking off fixed jaw plate wedge springs (3) and fitting the nuts.

Tools to use

- (1) Extension socket: Accessory Tool No.10
- (2) Ratchet handle: Accessory Tool No.11
- (3) Extension piping: Accessory Tool No.12
- (4) 2 shackles: Accessory Tool No.17
- (5) Swing jaw stopper: Accessory Tool No.20
- (6) 2 wood chips: Accessory Tool No.26
(45 x 45 x 250 mm)
- (7) 2 bars
- (8) Sledge-hammer

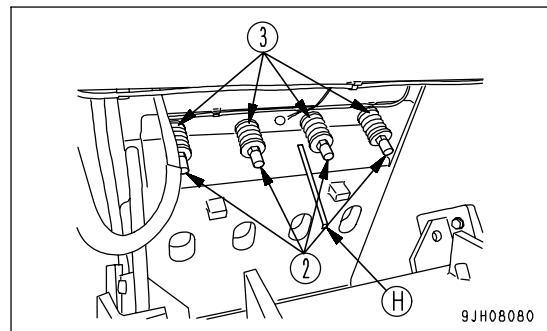

REMARK

Applicable shackle

Nominal size (a): 16 mm (5/8 inch)

Length (b): More than 32 mm (D type, wide D type)

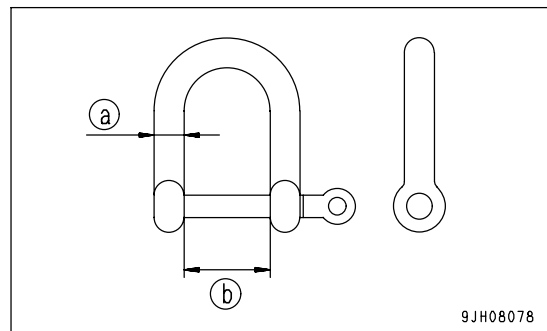

3. Loosen the mesh by hitting (4) swing jaw plate wedge with sledge-hammer.

(Another method: Insert swing jaw stopper (tool No.20) in the hole of center of swing jaw back side, and push out (4) swing jaw plate wedge using hammer.)

4. Hold up the swing jaw plate wedge of one side obliquely upward using bar, and hold it with wood chip. Hold up another side likewise, and hold it with wood ship.

5. Connect the wire rope to 2 bolt holes of outer side with shackle.

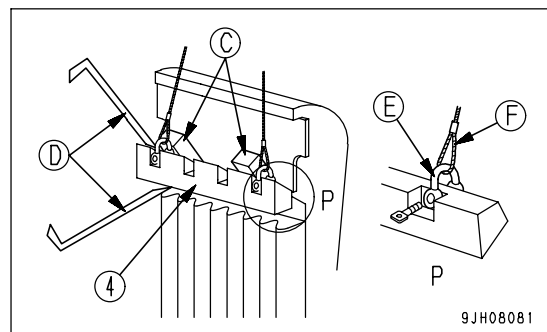

6. Remove 2 bolts of center part after hanging the wire rope on the hook of crane to fix the swing jaw plate wedge.
(Swing jaw plate wedge weight: 76 kg)
7. Fix wire ropes to the hooks on both sides of swing jaw plate (5) and lift it up.
[Swing jaw plate weight: 1110kg (2448 lb)]

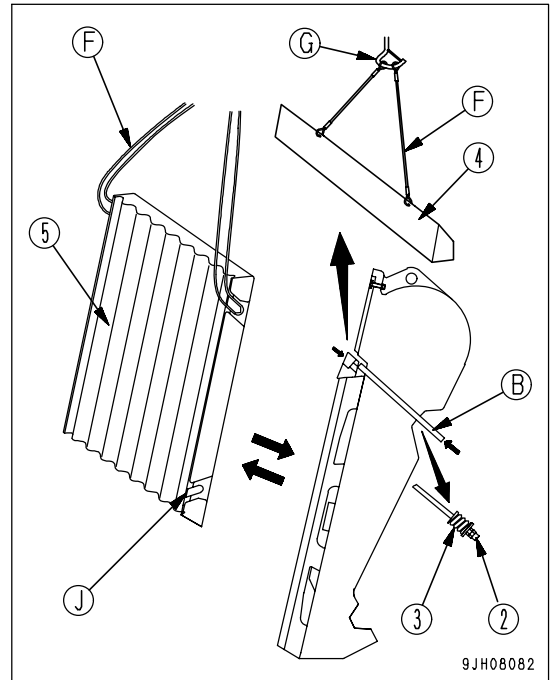

! CAUTION

After detaching the swing jaw plate, completely remove soils, sand, etc. from the swing jaw plate fitting surfaces (swing jaw, each upper surface of swing jaw plate mount stopper and transverse stopper piece)
If not removed completely, they may cause a backlash on the swing jaw plate.

- When reversing the swing jaw plate, lower it on to a block once. Then fix a wire rope on the opposite side, lift it up and push it back into the crusher frame.
 - When replacing the swing jaw plate, lower the worn plate on to a block once. Lift up a new swing jaw plate with a wire rope and insert it into the crusher frame.
8. Secure swing jaw plate wedge (3) and swing jaw plate wedge bolts (1).
Set the length (B) of the fixed jaw plate wedge bolt spring at 103 mm (3.9 in) to 105 mm (4.13 in).

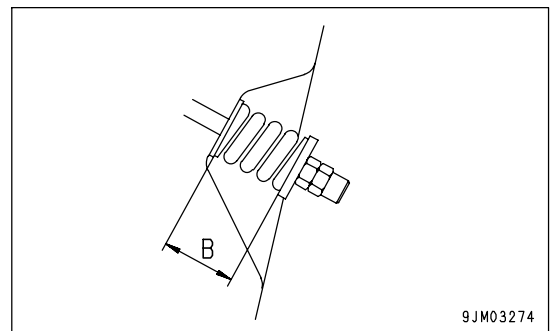

REPLACEMENT OF TOGGLE PLATE

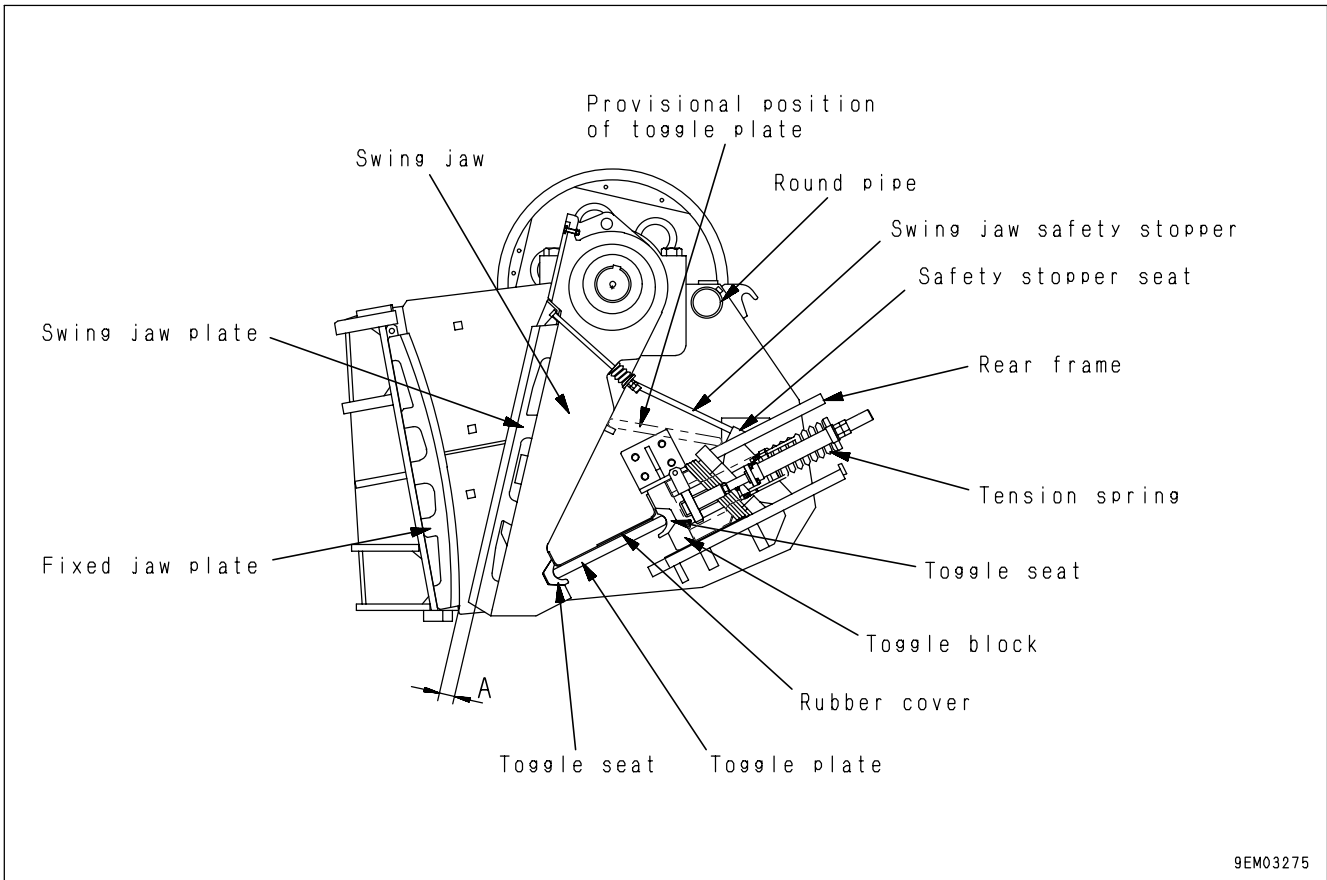

9EM03275

1. Remove rubber plate (1) and swing jaw cover (2).
2. Detach each working deck in the order of crusher interior maintenance floor (3) and crusher front maintenance floor (4).
3. Remove rubber cover (2) that is spread over the toggle plate. (M10 bolt x 10 pieces)

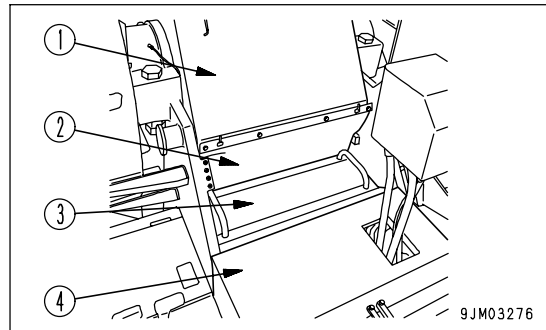

9JM03276

4. Pass a wire rope through an eyebolt on the toggle plate (5) to lift it up provisionally.
 Insert the eyebolt through a tap hole on the toggle block side.
 Tool to use
 Eyebolt (M20): Accessory Tool No.16

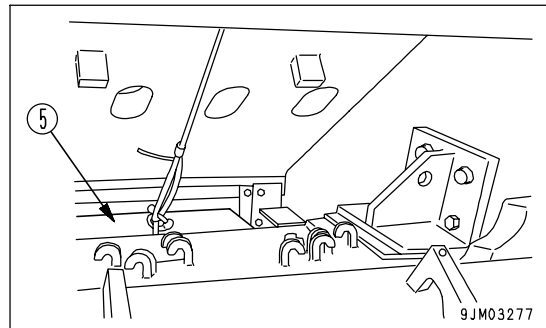

9JM03277

REMARK

When replacing a worn toggle plate, pass a wire rope through a long hole on the toggle plate, because it has been deformed, and lift it up provisionally,.

⚠ WARNING

It is very dangerous to proceed to the next work without loosening tension spring (6) completely. Be sure to remove the tension spring nut (M42) from the rod.

5. Loosen tension spring (6) completely (both sides: M42)
 - (1) Single-ended spanner: Accessory Tool No.5
 - (2) Extension piping: Accessory Tool No.12
6. Start the engine.
7. Set operation mode selector switch (8) to the INSPECTION position.
8. Attach a warning tag to announce to those concerned that the the machine is now worked on.
9. Keep depressing crusher outlet clearance reduction switch (9) in the upper control box to advance the toggle block until the swing jaw plate comes to contact with the fixed jaw plate. (Remove all the inserted shims)
10. Take out swing jaw stopper (10) and insert it into the swing stopper seat without fail.

Tool to use

Swing jaw stopper: Accessory Tool No. 20
11. Depress crusher outlet clearance expansion switch (11) in the upper control box to pull back the toggle block, and support the swing jaw with the swing jaw stopper.
12. Stop the engine.

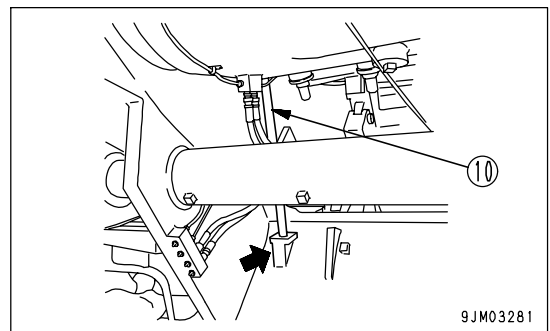
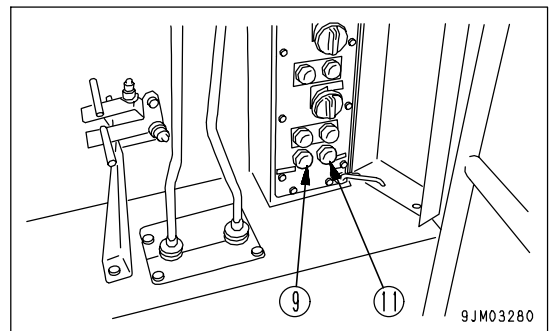
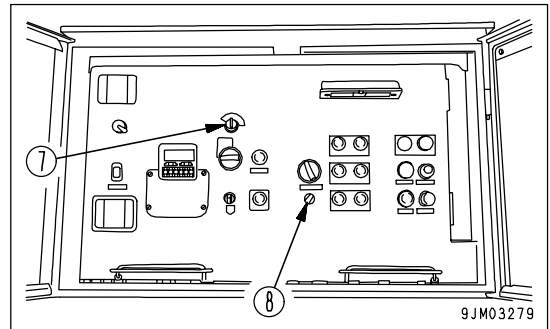
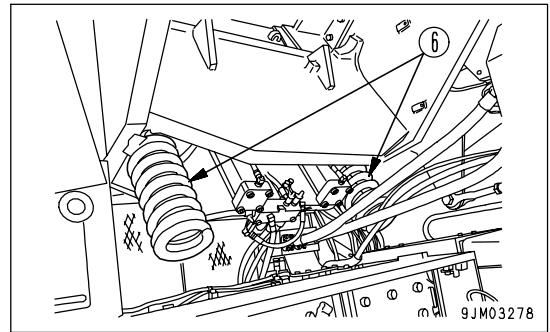

13. Lift up the toggle plate and place it provisionally between the toggle block and the backside of the swing jaw. Hook the wire rope to it again on the outside of the round pipe.

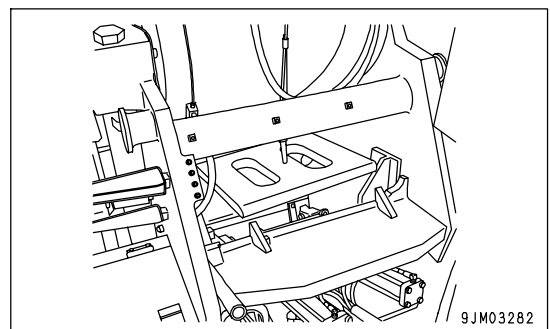

- 14. Take out the toggle plate.
[Toggle plate weight: 136 kg (295 lb)]

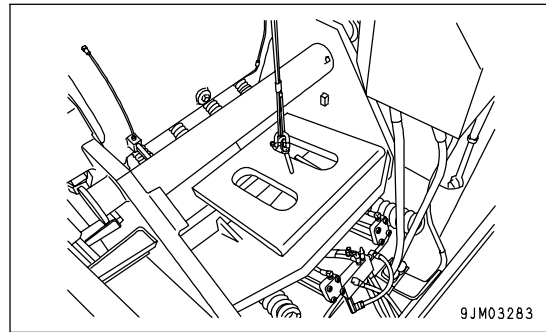

- 15. Fix an eyebolt on tap (B) of a new toggle plate and wind a wire rope around it.

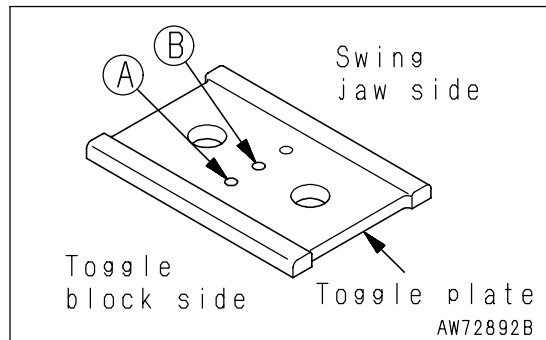

- 16. Lift up the toggle plate and place it on the crusher rea frame provisionally.
- 17. Hook the wire rope again to let it through between the round pipe and swing jaw.

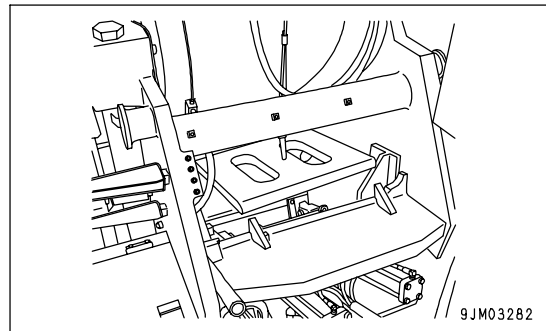

- 18. Lower the toggle plate slowly and match it to the center of the seat on the toggle block side.
- 19. Start the engine.
- 20. Set the operation mode selector switch to the INSPECTION position.
- 21. Attach a warning tag to the engine starting switch to announce to those concerned that the machine is now worked on.
- 22. Depress the crusher outlet clearance reduction switch in the upper control box, try to adjust the wire rope lifting length, while pushing the toggle block forward, and then determine a position where the front contact surface of the toggle plate and the contact surface of the swing jaw seat contact are aligned.
- 23. When the position has been determined, push the toggle block forward a bit further, and pull out the swing jaw stopper from the stopper seat.
- 24. Stop the engine.
- 25. Remove the wire rope and eyebolt fitted to the toggle plate.

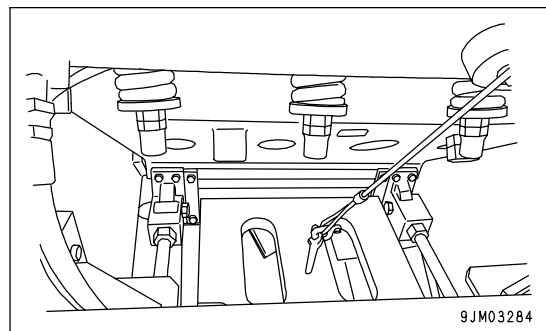

26. Install the tension spring and compress it to the specified length.
 Set the tension spring compression length (C) to 388 mm (13.3 in).

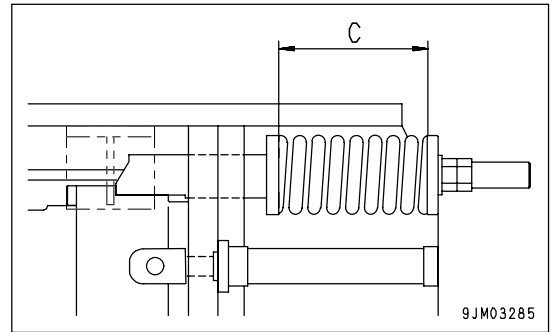

27. Install two rubber covers on the toggle plate.
 (M10 bolt x 8 pieces)
28. Install each working deck in the order of crusher front maintenance floor and crusher interior maintenance floor.
29. Fix the swing jaw cover and rubber plate.
30. Check crusher outlet clearance (A) and adjust it to a desired clearance.
 For adjusting the crusher outlet clearance, see the section of "CHECK AND ADJUSTMENT OF OUTLET CLEARANCE (PAGE 4-36)".

REPLACEMENT OF TOGGLE SEAT



WARNING

Before replacing the toggle seat, never fail to observe the following instructions.

- Check that the swing jaw stopper is surely inserted into the stopper seat.
- After a long and continuous use of the machine, the toggle seat may have been deformed and firmly stuck to the toggle block or swing jaw. In such case, weld a hook to the toggle seat at the center, and pull out the worn toggle seat.

Depending on the situation, gas-cut the worn toggle seat.

(material of toggle seat: carbon steel)



CAUTION

The toggle seat has no parts interchangeability. Hence take care to install it rightly.

Toggle seat on swing jaw side: Protruding amount 25 mm (1.0 in) and protruding downward

Toggle seat on toggle block side: Protruding amount 50 mm (2.0 in) and protruding downward

1. Start with removing the toggle plate beforehand, referring to the section dealing with replacement of the toggle plate in this manual.
2. Remove toggle seat holding plates (1) on both sides of the swing jaw.

(bolt in use: M16 x 4 bolts)

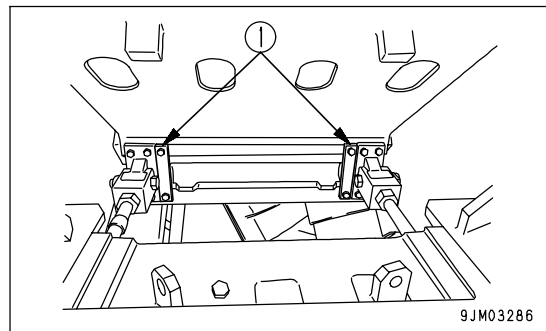

3. Screw an eyebolt (M12) into tap holes on both sides of the toggle seat and hook a wire rope to it.

Tool to use

Eyebolt: Accessory Tool No.14

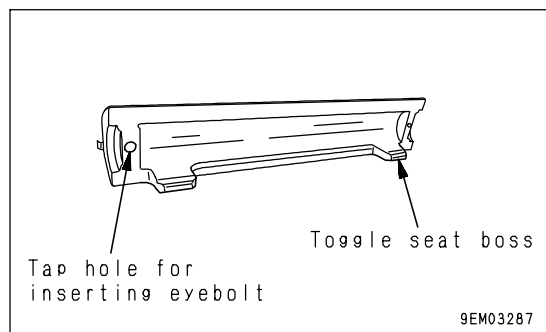

4. Lift up the toggle seat.

[Weight of toggle seat on swing jaw side: 38.6 kg (85 lb)]

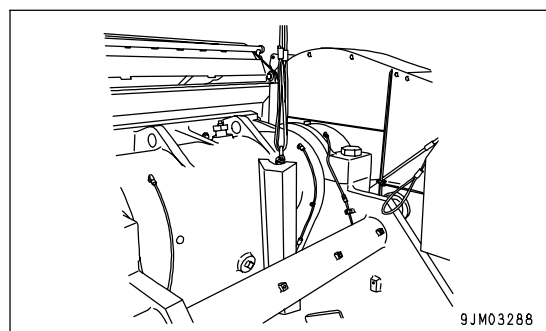

5. Remove toggle seat holding plate (2) only on one side of the toggle block.
6. Screw in an eyebolt (M12) on the side from which a holding plate has been removed and lift up the toggle seat provisionally, taking care not to let it fall.
7. When the work of lifting up the toggle seat provisionally has been completed, proceed to remove a toggle seat holding plate on the opposite side.
8. Screw in eyebolts on both sides of the toggle seat on the toggle block side and lift up the toggle sheet.
[Toggle seat weight on toggle block side: 39.0 kg (86 lb)]
9. Insert new toggle seats in the reverse order of the works explained above.

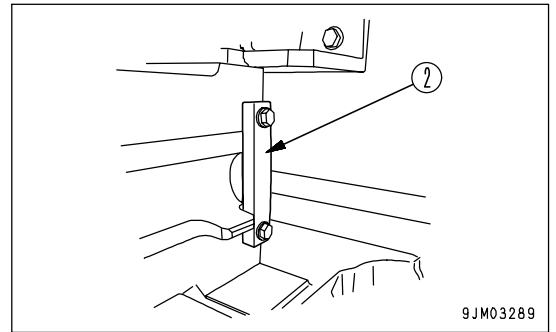

REPLACEMENT OF CRUSHER DRIVING V-BELT

1. Take out maintenance ladder (1) stored under the primary belt conveyor.

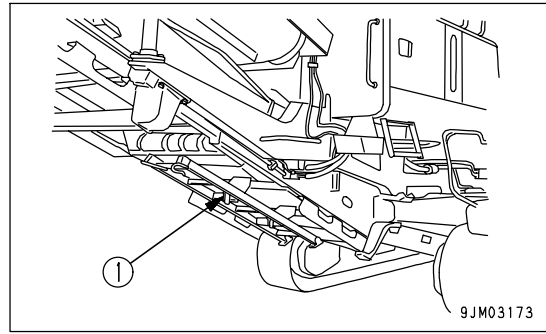

2. Hook the ladder to a pipe provided under the flywheel cover on the left side of the machine.

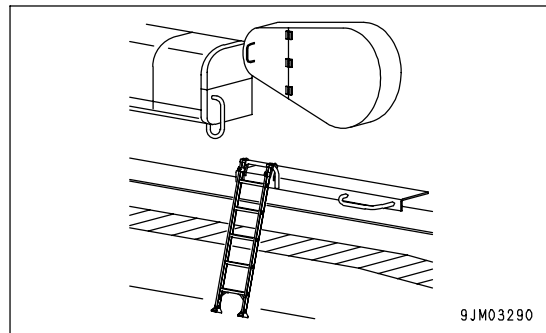

3. Open left flywheel cover (2).

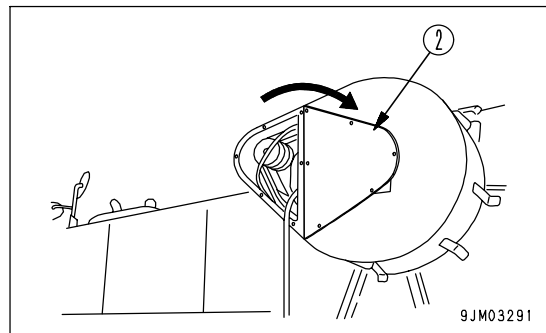

- 4. Open front cover (2) of the left flywheel cover.
- 5. Loosen a turnbuckle on the crusher motor bracket and remove the V belts.
- 6. Insert new V belts and fit them to V sheaves from the innermost one in order, utilizing the hole of cover (2).
- 7. After installing all the V belts (six in total), tighten them to the specified tension, using the turnbuckle.
- 8. Fix covers (1) and (2).

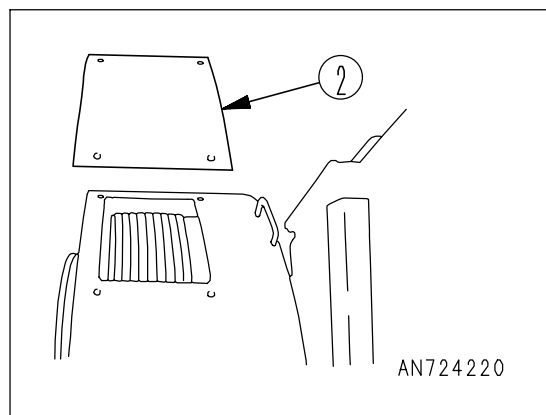

CHECK AND ADJUSTMENT OF PRIMARY CONVEYOR

 **WARNING**

When inspecting and cleaning the primary conveyor and its surrounding, there is always the danger that you are caught in a revolving parts. Be sure to start the work only after stopping the belt conveyor.

CHECK AND ADJUSTMENT OF SNAKY MOVEMENT OF CONVEYOR BELT

 **CAUTION**

If it becomes necessary to work on the adjust bolts, start with the work only after stopping the engine.

If the conveyor belt makes a snaky movement, adjust the tension on the left and right sides by turning the adjust bolts.

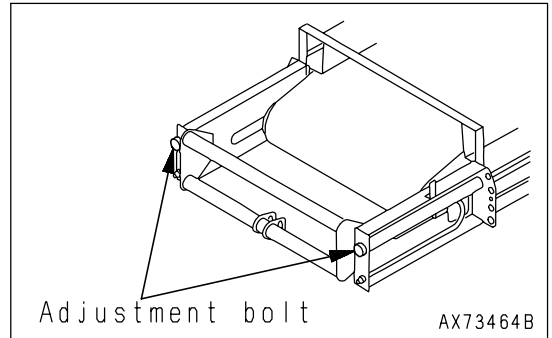

ADJUSTMENT OF CONVEYOR SIDE RUBBER

If the conveyor side rubber has been worn out, creating a clearance between the rubber and belt, loosen the adjustment bolt. (Standard clearance 0 mm, i.e. close contact)

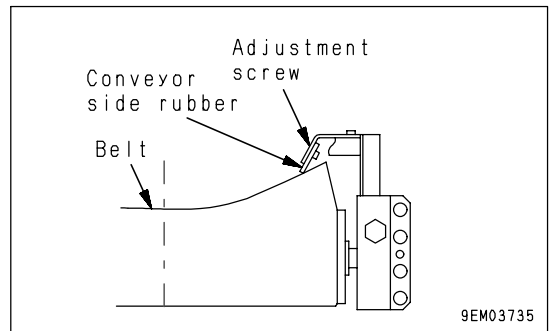

ADJUSTMENT OF SCRAPER

DRIVING PULLEY SIDE

Get rid of the clearance between the belt cleaner tip and belt with the adjusting bolt so that they come to close contact. (standard clearance 0 mm)

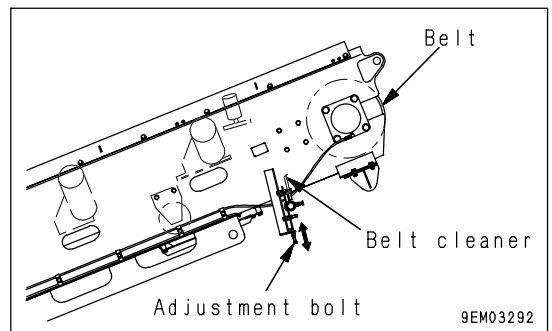

DRIVEN PULLEY SIDE

If the scraper rubber has been worn out, replace it by loosening the securing bolts.

(It is in even contact with the belt across the width)

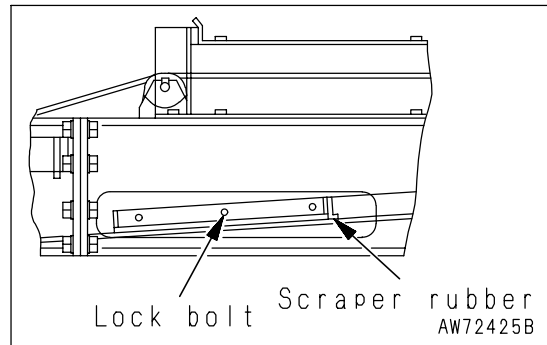

CHECK BEFORE STARTING

For the following items, see "CHECK BEFORE STARTING (PAGE 3-35)".

- Checks and cleaning of radiator fins and oil cooler fins
- Check coolant level, add water
- Check oil level in engine oil pan, add oil
- Check fuel level, add fuel
- Check oil level in hydraulic oil tank, add oil
- Check air cleaner for clogging
- Check electric wiring
- Check function of horn
- Adjustment of rear view mirror
- Check of jaw crusher
- check of Bear-Loc cylinder for locking force
- Check of primary conveyor
- Check of grizzly feeder

EVERY 100 HOURS SERVICE

GREASING CRUSHER BEARING SEAT

Provide grease to the grease fittings indicated with an arrow in the figure at right (4 places).

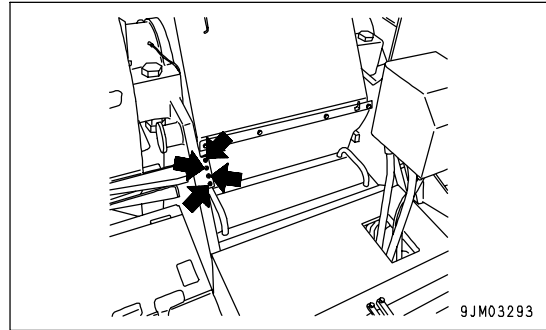

DRAIN WATER, SEDIMENT FROM FUEL TANK

NOTICE

Do not use trichloroethylene for cleaning the interior of the fuel tank.

1. Carry out this procedure before operating the machine.
2. Prepare a container to catch the fuel that is drained.
3. Open drain valve (1) provided under the fuel tank to drain sediments and water accumulated on the tank bottom. At that time, take care not to get splashed with fuel.
4. When only clean fuel begins to flow out, close drain valve (1).

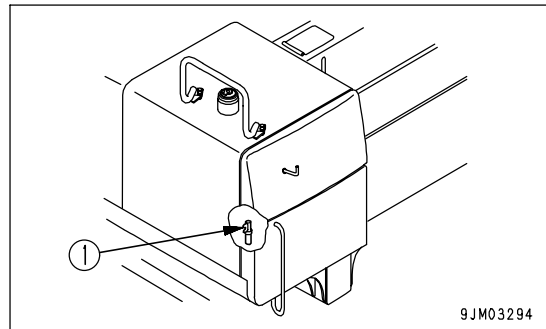

GREASING PRIMARY CONVEYOR

1. Greasing pillow blocks of of head pulley (2 places)

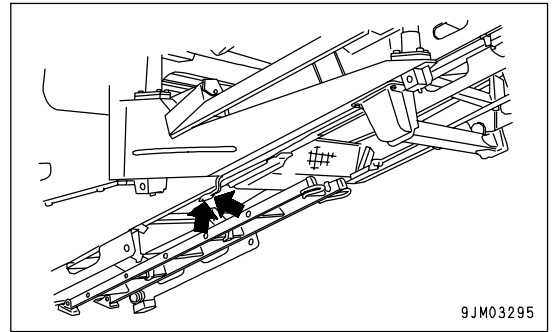

2. Greasing tail pulley bearings (2 places on both sides)

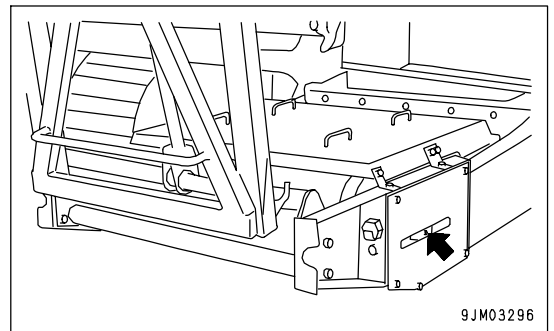

EVERY 250 HOURS SERVICE

CHECK LEVEL OF BATTERY ELECTROLYTE



WARNING

- To avoid gas explosions, do not bring fire or sparks near the battery.
- Battery electrolyte is dangerous. If it gets in your eyes or on your skin, wash it off with large amounts of water, and consult a doctor.

Perform this check before operating the machine.

WHEN CHECKING ELECTROLYTE LEVEL FROM BATTERY SIDE

1. Open the battery box cover on the right side of the machine.
2. Remove cap (1) and check that the battery electrolyte is up to the UPPER LEVEL line. If the level is low, add distilled water to the UPPER LEVEL line.

Do not add water above the UPPER LEVEL line. This may cause leakage of the electrolyte, which may cause fire.

3. Clean the air breather in the battery cap, then tighten cap (1) securely. Keep the top of the battery clean and wipe with a damp cloth.

When adding distilled water in cold weather, add it before starting operations in the morning to prevent the electrolyte from freezing.

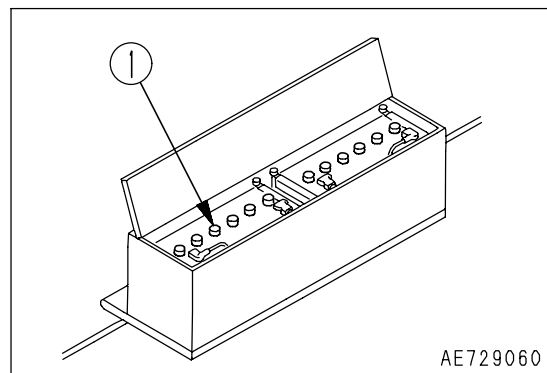

WHEN CHECK FROM BATTERY SIDE IS NOT FEASIBLE

Check the line for the battery electrolyte level as follows.

1. To judge the position of the electrolyte level, remove cap (1), look through the filler port, and check if the electrolyte level reaches the sleeve.

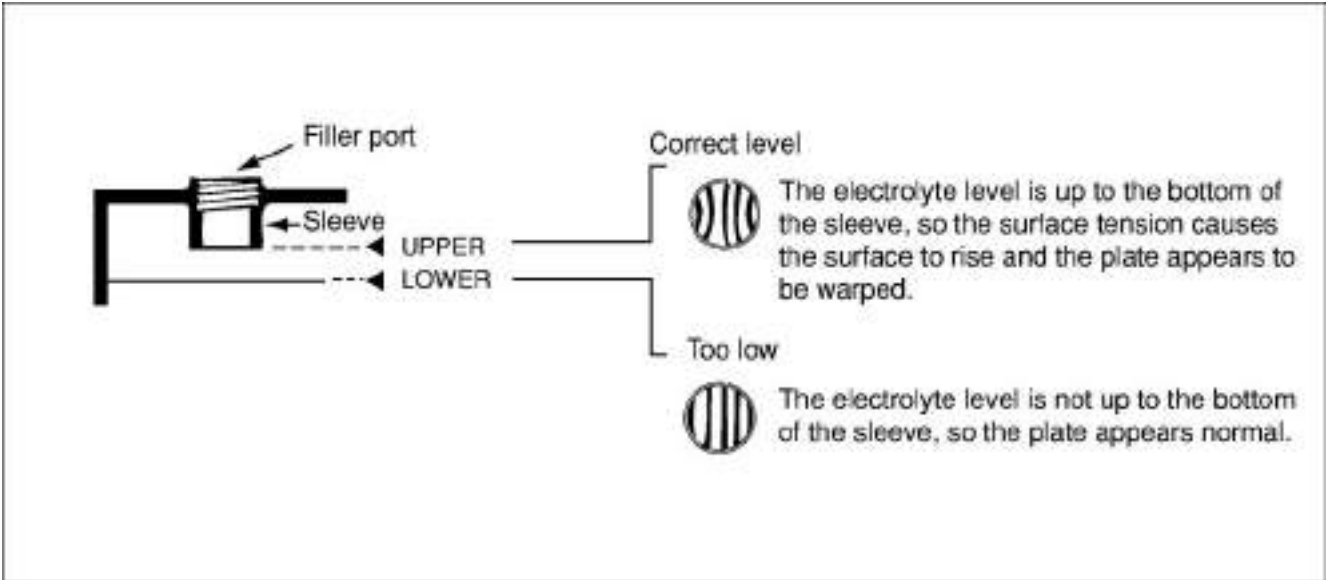

NOTICE

When adding distilled water in cold weather, add it before starting operations in the morning to prevent the electrolyte from freezing.

2. Clean the air breather in the battery cap, then tighten cap (1) securely. Keep the top of the battery clean and with a damp cloth.
When adding distilled water, wait until starting operations next morning in order to prevent the electrolyte from freezing.

REMARK

If water is added to above the bottom tip of the sleeve, use a pipette to remove electrolyte. Neutralize the removed electrolyte with sodium bicarbonate, then flush it away with a large amount of water. If necessary, contact your Komatsu distributor or your battery maker.

CHECK FAN BELT AND ALTERNATOR BELT TENSION, ADJUST

NOTICE

Check and adjust the tension of the engine fan belt and alternator belt, using the step for engine maintenance.

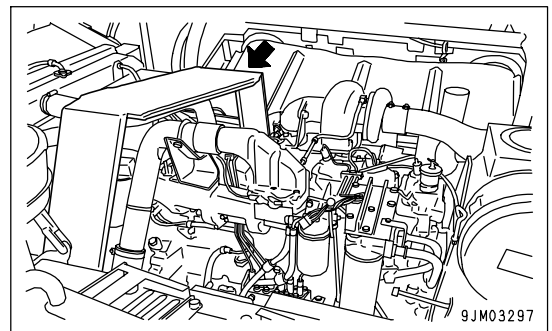

CHECKING

Depress the belt with a thumb at the midpoint between the alternator pulley and fan pulley. If the belt deflects by approx. 13 mm (0.5 in) with applied pressure of approx. 6 kg (58.8 N), the tension is normal.

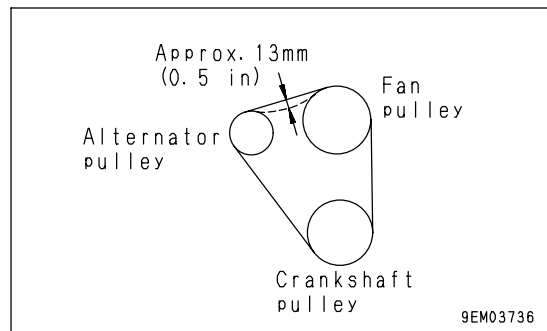
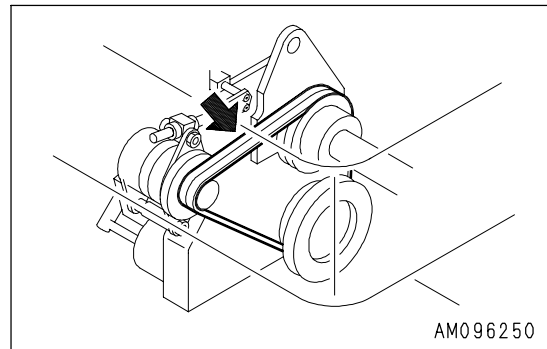
**ADJUSTMENT**

1. Loosen bolts and nuts (1), (2), (3).

Turn nut (4) clockwise to move alternator (5) so that the belt deflects by approx. 13 mm (0.5 in) with applied force of approx. 6 kg (58.8 N).

2. Tighten bolts and nuts (1), (2) and (3) to secure alternator (5).

Tightening torque

Lock nut(1) and (4): $137.2 \pm 53.9 \text{ N}\cdot\text{m}$ ($14 \pm 5.5 \text{ kgf}\cdot\text{m}$, $101.3 \pm 39.8 \text{ lbft}$)

Bolt(2): $33.3 \pm 4.9 \text{ N}\cdot\text{m}$ ($3.4 \pm 0.5 \text{ kgf}\cdot\text{m}$, $24.6 \pm 3.6 \text{ lbft}$)

Bolt(3): $127.4 \pm 19.6 \text{ N}\cdot\text{m}$ ($13 \pm 2 \text{ kgf}\cdot\text{m}$, $94.0 \pm 14.5 \text{ lbft}$)

3. Check for damage to the pulleys, and wear of the groove and belt. Be particularly careful to check that the belt is not in contact with the bottom of the groove.
4. If the belt has elongated and there is no more allowance for adjustment, or if the belt is cut or cracked, replace the belt.
5. After replacing the belt, operate for one hour, then adjust again.

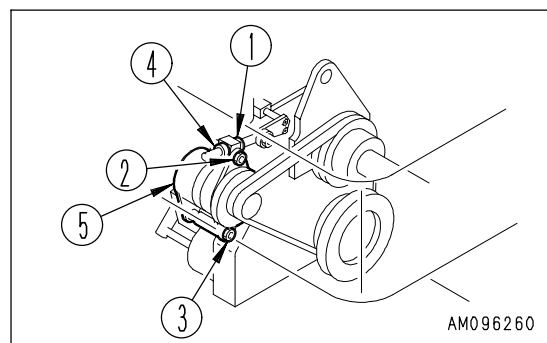

CHECK AND ADJUSTMENT OF JAW CRUSHER V-BELT

CHECKING

1. Open the V belt inspection hole and measure the tension of each V belt with a tension meter.
For the measurement method, refer to the section dealing with inspection of jaw crusher.

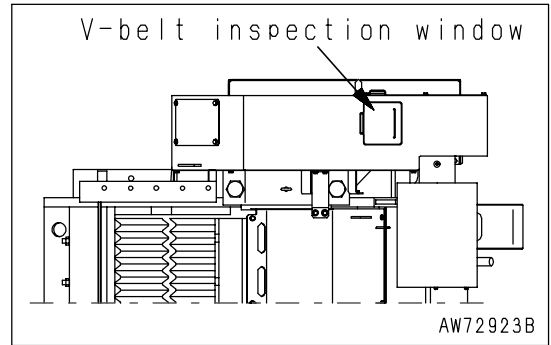

2. Calculate the average of the measured tension values. In case the average tension value obtained lowers 85.0N(8.7kgf), tighten the V belts in the following procedures.
For the details on inspection and adjustment of the V belts, refer to the chapter, "CHECK OF JAW CRUSHER AND RELATED ACCESSORIES (PAGE 3-44)" in this manual.

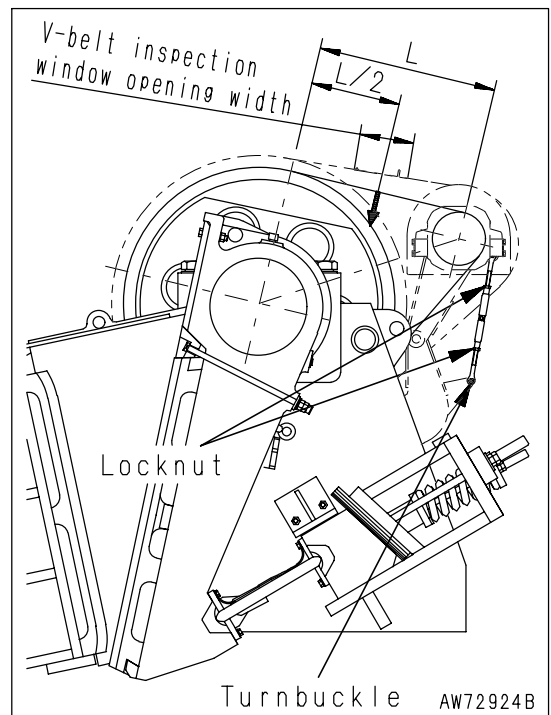

ADJUSTMENT

⚠ CAUTION

V belts have a characteristic that their tension tends to lower by 20-30% in 24 hours after the engine start. Hence measure the V belt tension every 24 operating hours and every 250 operating hours without fail. If the tension of any V belt is found below the lower limit, tighten it.

1. Loosen the turnbuckle lock nut.
2. Turn the turnbuckle with a monkey wrench to tighten the V belt.
3. Measure each V belt for tension with a tension meter and adjust the tension to obtain an average value of 109N(11.1kgf).
* With new V belts, adjust them to obtain an average tension value of 125N(12.7kgf).
4. Tighten the turnbuckle lock nut.

CHECK OF OIL LEVEL IN CRUSHER MOTOR BEARING CASE AND ADDING OIL

1. Unscrew oil filler plug (F) and loosen oil check port (A). If oil seeps out, the oil level is normal.
2. If oil is short, add it through oil filler plug (F) until oil overflows from oil check port (A).

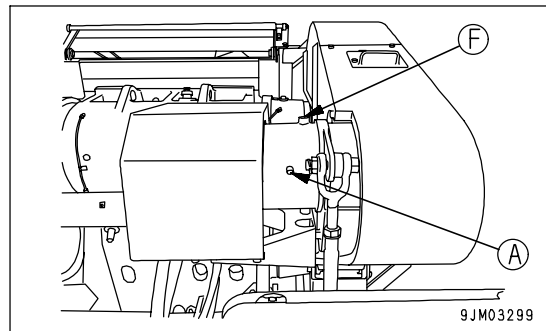
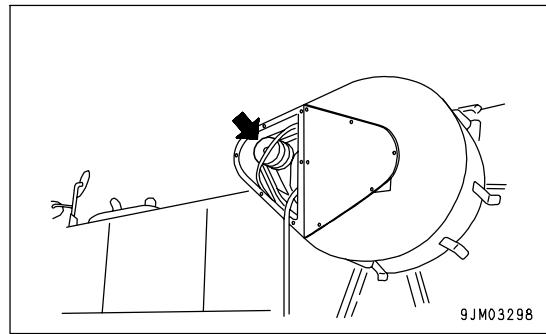

CHANGE OIL IN ENGINE OIL PAN, REPLACE ENGINE OIL FILTER CARTRIDGE

WARNING

Do not try to change oil, once the engine is started, since various parts of the engine have already been warmed up to a high temperature. Replace the engine oil, after the engine cools down.

- Container with capacity over 34 liters (8.98 US gal) to receive drained oil
- Replacement oil amountof oil pan 34 liters (8.98 US gal)
- Filter wrench

1. Take out maintenance ladder (1) stored under the primary belt conveyor.
2. Hook the ladder to a pipe located under a door on the right side at the rear of the machine.
3. Open the door on the left side at the rear of the machine.
4. Remove the inspection lid on the undercover located direct under an extension hose for draining the engine oil, and place a container beneath.
5. Drain the engine oil by raising the drain valve lever slowly. After all the oil has been drained, lower the level to close the drain valve.

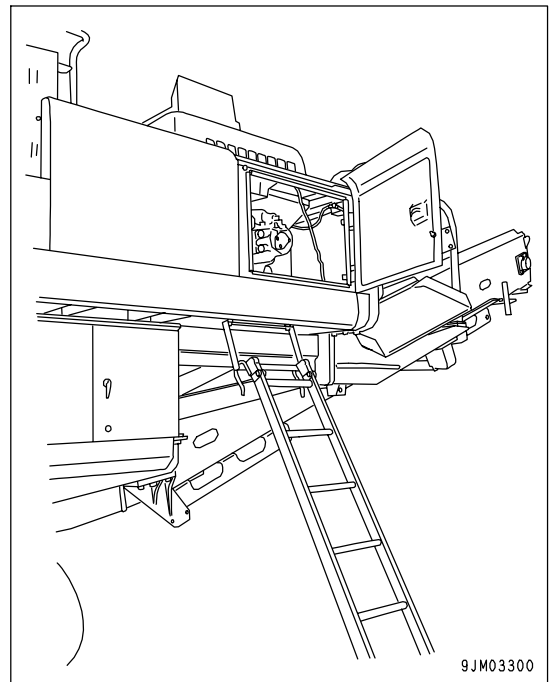

6. Open the engine hood, and in order to remove the filter cartridge, turn it to the left with a filter wrench from above the engine. A lot of oil will flow out just after the engine stops, so wait for about ten minutes before starting the job.
7. Clean the filter stand. Fill a new filter cartridge with clean engine oil. Coat clean engine oil on the packing and threads of the new filter cartridge (a thin layer of grease will do, too), and then install the filter cartridge.

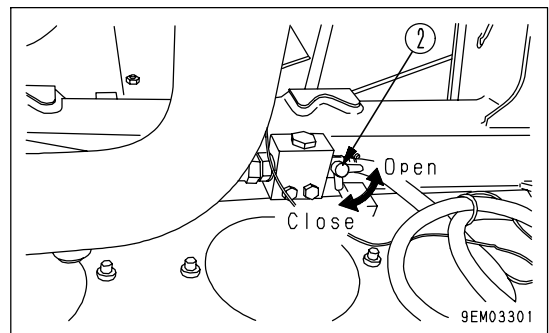

REMARK

Check that there is no old packing affixed to the filter holder. If there is any old packing affixed to the filter, it will cause leakage of oil.

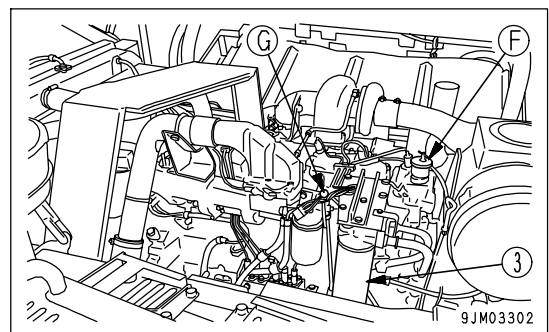

8. When installing, tighten until the packing surface of the cartridge contacts the seal surface of the filter holder, then tighten a further 3/4 to 1 turn.
9. After replacing the filter cartridge, add engine oil through oil filler port (F) so that the oil level is between the H and L marks on dipstick (G).
10. Run the engine at low idling for some time and stop it. Then, referring to the section of "CHECK OIL LEVEL IN ENGINE OIL PAN, ADD OIL (PAGE 3-37)", check that the engine oil amount is at the H-L level in the engine oil level gauge.
11. Close the door on the right side at the rear of the machine and store the maintenance ladder.

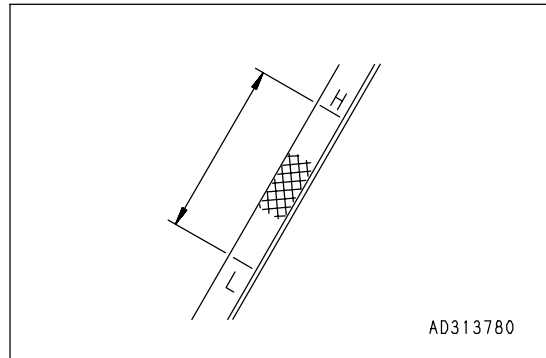

EVERY 500 HOURS SERVICE

Carry out periodic maintenance work of every 100 and 250 hours of operation at the same time.

REPLACE FUEL FILTER CARTRIDGE



WARNING

- The engine is at high temperature immediately after the machine has been operated. Wait for the engine to cool down before replacing the filter.
- Do not bring fire or sparks near the fuel.

Prepare a filter wrench and a container to catch the fuel.

1. Set the container to catch the fuel under the filter cartridge.
2. Using a filter wrench, turn filter cartridge (1) counterclockwise to remove it.
3. Clean the filter holder. Fill a new filter cartridge with clean fuel. Coat the packing surface with engine oil. Then install the new cartridge into the filter holder.
4. When installing, screw in cartridge until seal comes in contact with sealing surface, then tighten approx. 2/3 turn.
If the filter cartridge is tightened too far, the packing will be damaged and this will lead to leakage of fuel. If the filter cartridge is too loose, fuel will also leak from the packing, so always tighten to the correct amount.

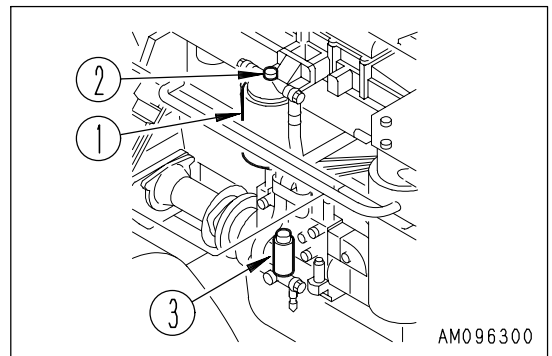

5. After replacing the fuel filter cartridge, bleed the air from the system.
Bleed the air as follows.
6. Fill the fuel tank with fuel (to the position where the float is at the highest position).
7. After replacing filter cartridge (1), loosen air bleed plug (2).
8. Loosen the knob of feed pump (3), operate it up and down, and continue until no more bubbles come out with the fuel from air bleed plug (2).
9. Tighten air bleeding plug (2).
A genuine Komatsu filter cartridge is recommended for use.
After finishing the replacement of the filter cartridge, start the engine and check that there is no oil leakage from the filter seal surface.

CHECK OIL LEVEL IN FINAL DRIVE CASE, ADD OIL

**WARNING**

- The oil still remains at high temperature just after an operation is finished. Start the job after the oil temperature cools down.
- If pressure is left in the final drive case, oil may spurt out or the plug may fly off. Loosen the plug slowly to relieve the internal pressure.

- Prepare a handle.

1. Set the TOP mark at the top, with the UP mark and plug (P) perpendicular to the ground surface.
2. Remove plug (F) using the handle. When the oil level reaches a point 10 mm (0.4 in) below the bottom of the plug hole, the correct amount of oil has been added.
3. If the oil level is too low, install plug (F), operate the travel levers, and drive forward or in reverse to rotate the sprocket one turn. Then repeat Step 2 to check again.
4. If the oil level is low, add engine oil through plug hole (F) until the oil overflows from plug hole (F).
5. After checking, install plug (F).

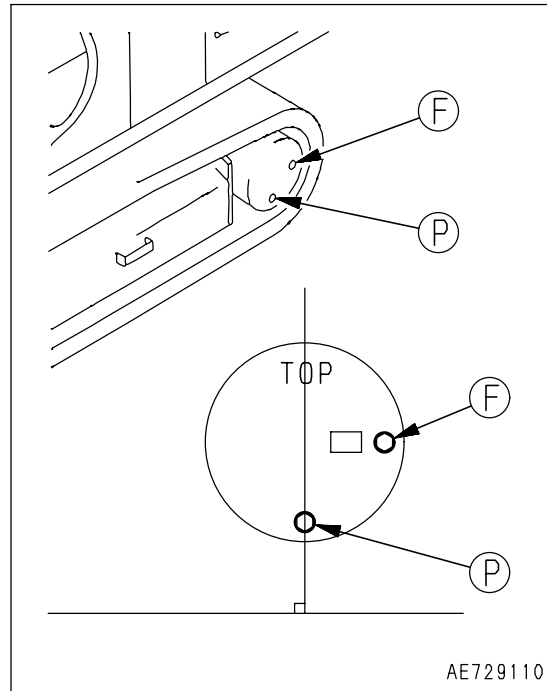

REPLACE HYDRAULIC FILTER ELEMENT



WARNING

- The parts and oil are at high temperature immediately after the engine is stopped, and may cause burns. Wait for the temperature to go down before starting the work.
- When removing the oil filler cap, turn it slowly to release the internal pressure, then remove it.

1. Remove the cap from oil filler (F), and release the internal pressure.
2. Loosen 4 bolts, then remove cover (1).
When doing this, the cover may fly out under the force of spring (2), so hold the cover down when removing the bolts.
3. After removing spring (2) and valve (3), take out element (4).
4. Clean the removed parts in diesel oil.
5. Install the new element in the place where old element (4) was installed.
6. Set valve (3) and spring (2) on top of the element.
7. Set cover (1) in position, push it down by hand, and install the cover with the mouning bolts.
8. Screw in the oil filler cap and install the cover.
9. To bleed the air, start the engine according to "STARTING ENGINE (PAGE 3-49)" and run the engine at low idling for 10 minutes.
10. Stop the engine.

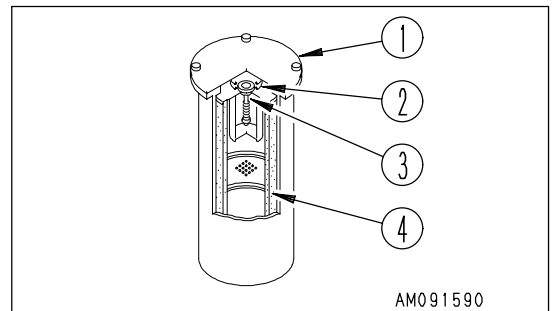
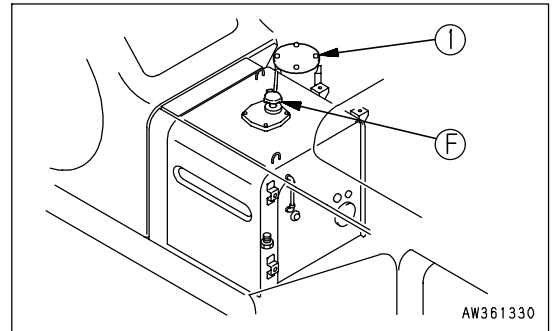

REMARK

Wait for at least 5 minutes after stopping the eigne to eliminate bubbles in the oil inside the tank.

11. Check for oil leakage and wipe off any spilled oil.

CLEAN AND INSPECT RADIATOR FINS, OIL COOLER FINS**WARNING**

If compressed air, high-pressure water, or steam hit your body directly, or they cause dirt or dust to be blown up, there is a hazard of serious injury. Always use safety glasses, dust mask, or other protective equipment.

NOTICE

When using compressed air, keep the air nozzle at a distance to prevent damage to the fins. Especially for the aftercooler, blow the air from 300 mm (11.8 in) or more, and at a 45 degree angle.

To prevent damage to the fins, apply compressed air from an appropriate distance. Damaged fins may cause water leakage or overheating. On dusty sites, check the fins daily, regardless of the maintenance interval.

- Inspect and clean the radiator fins and oil cooler fins, using the maintenance ladder.

1. Open the engine hood and the door on the left side at the rear of the machine.
2. Blow off with compressed air dirt, dust, tree leaves, etc. clogging the radiator fins and oil cooler fins (1). Clean the net in front of the oil cooler at the same time.
Steam or water will do instead of compressed air.
3. Check the rubber hose. Replace with a new one if the hose is found to have cracks or to be hardened by ageing.
Also, check hose clamps for looseness.

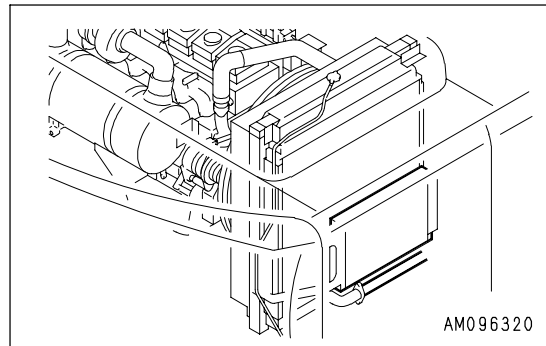

REPLACE HYDRAULIC TANK BREATHER ELEMENT

**WARNING**

- The parts and oil are at high temperature immediately after the engine is stopped, and may cause burns. Wait for the temperature to go down before starting the work.
- When removing the oil filler cap, turn it slowly to release the internal pressure, then remove it.

1. Remove the cap of oil filler (F) at the top of the hydraulic tank.

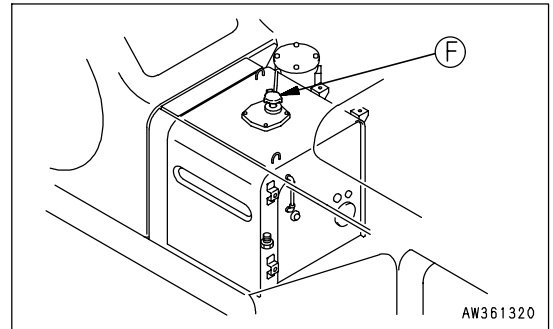

2. Replace element (1) inside the cap.

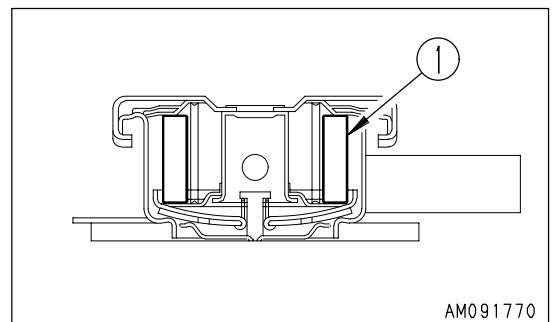

EVERY 1000 HOURS SERVICE

Carry out the periodic maintenance work of every 100, 250 and 500 hours of operation at the same time.

CHANGE OF OIL IN CRUSHER MOTOR BEARING CASE

1. Remove drain plug (P) to drain oil and screw it in after the drainage.
2. Add engine oil through oil filler port (F) to the specified amount.
Replacement amount of engine oil 8.1 liter (2.14 US gaal)
3. When oil begins to flow out from plug hole (A), stop adding oil and tighten plug hole (A) and the plug of oil filler port (F).

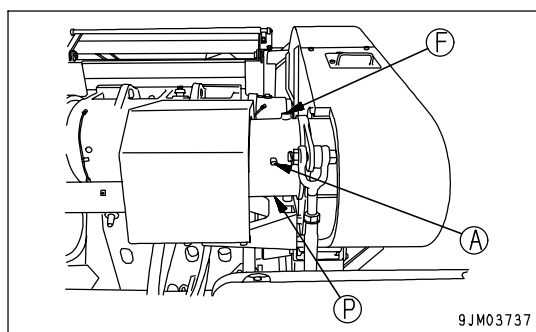
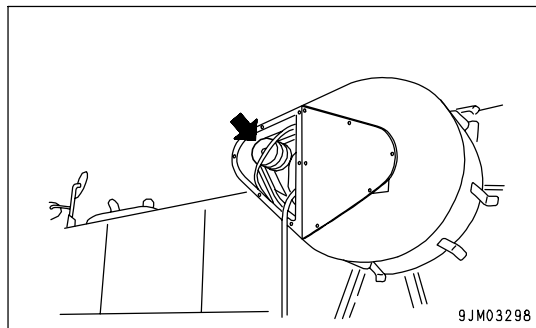

CHANGE OF OIL IN GRIZZLY FEEDER VIBRATOR CASE

OIL LEVEL

The optimum amount of oil is when the oil level points to the middle of the oil level gauge [15 liters (3.96 US gal)]. Remove the drain plug (P) to drain oil. For adding oil, remove the oil filler plug (F) and add oil until the oil level comes up to the middle of the level gauge (G).

Be sure to keep the oil amount at the optimum level, since both excessive and insufficient amount of oil can cause failures.

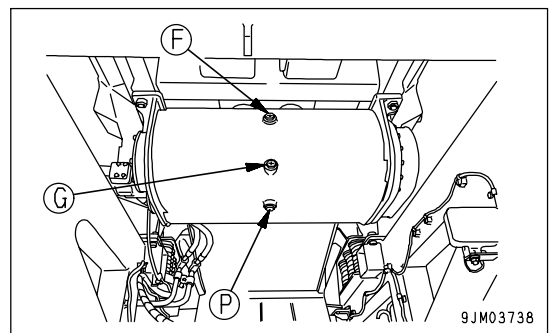
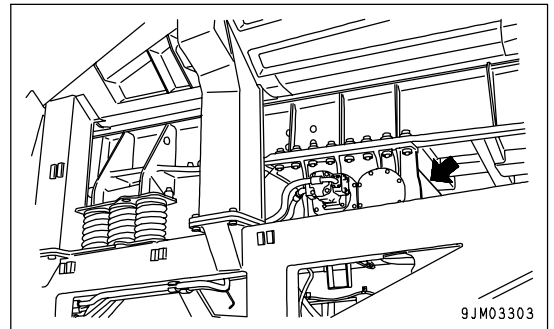

CHANGE OF OIL

Replace all the oil at the initial 250 hours of operation. Thereafter replace it completely roughly every 1000 hours of operation. Should the oil amount decrease even before each periodic replacement time, add oil properly. When using oil of different brand anew, replace all the oil so that two different brands of oil are not blended in the vibrator case.

CHANGE OIL IN DAMPER CASE**WARNING**

The oil is at high temperature immediately after the machine has been operated. Wait for the oil to cool down before starting the operation.

NOTICE

For checking the oil level, park the machine on the flat ground, and start checking 30 minutes after the engine has stopped.

1. Open the cover located on the right side of the machine.
2. Remove plug (G) and check the oil level. If the oil level is near the bottom of the plug hole, the oil amount is at a proper level. If found short, remove plug (F) and replenish oil through plug (F) filler port up to the bottom of plug (G) hole.

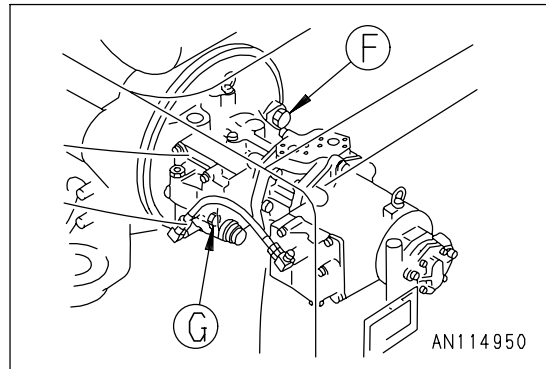
**NOTICE**

If excess oil is supplied, drain it to the specified amount to avoid overheating.

3. Install plugs (G) and (F).
4. Shut the door.

CHECK ALL TIGHTENING PARTS OF TURBOCHARGER

Contact your Komatsu distributor to have the tightening portions checked.

CHECK PLAY OF TURBOCHARGER ROTOR

Contact your Komatsu distributor to have the tightening portions checked.

REPLACE CORROSION RESISTOR CARTRIDGE

 **WARNING**

The oil is at high temperature after the engine has been operated, so never replace the cartridge immediately after finishing operations.

Wait for the oil to cool down before replacing cartridge.

1. Detach the step for engine maintenance.

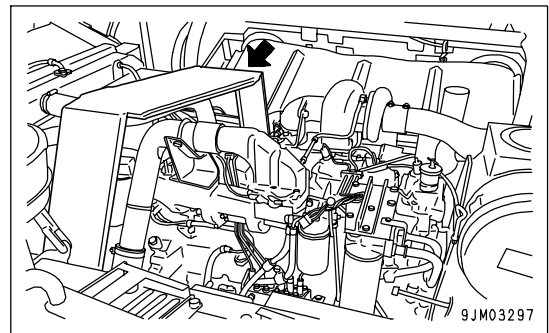

2. Screw in valve (1) at the top of the corrosion resistor.
3. Using a filter wrench, turn cartridge (2) to the left to remove it.
4. Install a new filter cartridge after coating engine oil on its sealing face.

In the installation, turn the cartridge by two-thirds of one turn after the packing surface comes to contact with the sealing face of the cartridge stand.

A genuine Komatsu filter cartridge is recommended for use.

5. Open valve (1).
6. Run the engine and check that there is no leakage of water from the seal surface.
7. When checking for water leakage is finished, stop the engine and fix the step for engine maintenance.

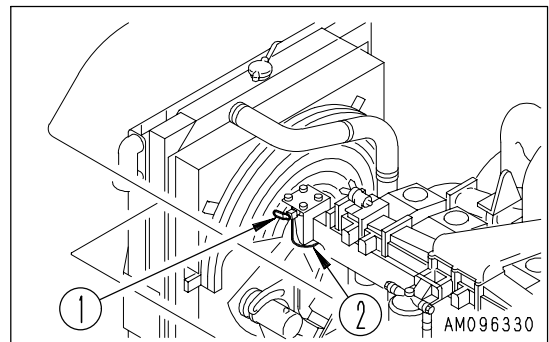

CHANGE OF OIL IN CONVEYOR MOTOR MACHINERY CASE

**WARNING**

The oil is at high temperature immediately after the machine has been operated. Wait for the oil to cool down before starting the operation.

NOTICE

For replacing oil in the conveyor motor machinery case, prepare a suitable scaffold for safety and commence the work.

[AGL height of conveyor motor machinery case: 3.0 m (9 ft 10 in)]

- A container of capacity over 2.5 liters (0.66 US gal) to receive drained oil
- Replacement amount of oil 2.5 liters (0.66 US gal)

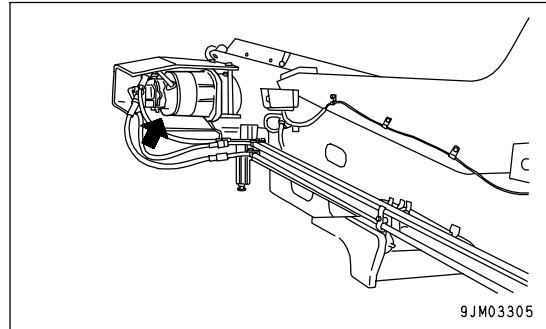

1. Set the container under the drain plug (P).
2. Unscrew drain plug (P) to drain oil, and tighten it after draining.
The specified drain plug tightening torque is 29.4 ± 9.81 N·m (3 ± 1 kgf·m, 21.7 ± 7.2 lbft)
3. Unscrew oil filler (F) cap and add oil through the oil filler port to the specified amount. (When oil is supplied to the specified amount, the oil level reaches two-thirds as high as the case ceiling)
4. Tighten oil filler (F) cap.

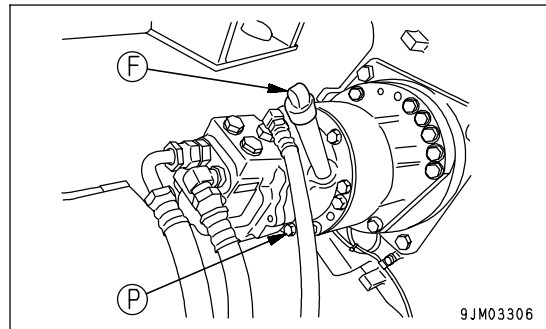

EVERY 2000 HOURS SERVICE

Maintenance for every 100, 250, 500 and 1000 hours should be carried out at the same time.

CHANGE OIL IN FINAL DRIVE CASE



WARNING

- The component parts and oil are warmed up to high temperature just after an operation. A casual touch will cause a burn. Hence start the replacement job after the temperature cools down.
- If pressure is still left in the case, oil may spurt out, or the plug may fly off. Release the internal residual pressure by turning the plug slowly.

- A container of capacity over 9.5 liters (2.51 US gal) to receive drained oil
- Replacement amount oil 9.5 liters (2.51 US gal) on right and left each
- Prepare a handle.
 1. Set the TOP mark at the top, with the TOP mark and plug (P) perpendicular to the ground surface.
 2. Place an oil receiving container under plug (P).
 3. Remove plugs (P) and (F), using a handle, to drain oil.

REMARK

Check an O-ring fitted to the plug for any damage, and replace it with new one, if judged necessary.

4. Tighten plug (P).
5. Add engine oil through the hole of plug (F).
6. When oil begins to overflow from the plug (F) hole, install plug (F).

Tightening torque of plugs (P) and (F):

$68.6 \pm 9.8 \text{ N}\cdot\text{m}$ ($7 \pm 1 \text{ kgf}\cdot\text{m}$, $50.6 \pm 7.2 \text{ lbft}$)

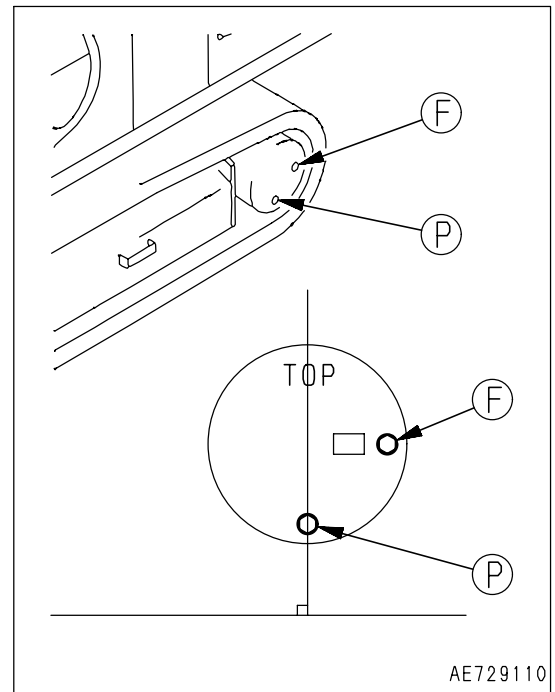

CHECK ALTERNATOR, STARTING MOTOR

Wear on the brush and the bearings short of grease are suspected, so ask the Komatsu distributor in your territory for the repairs.

NOTICE

If the engine is started frequently, shorten the periodic check interval to every 1000 hours of operation.

CHECK ENGINE VALVE CLEARANCE, ADJUST

As special tool is required for removing and adjusting the parts, you shall request Komatsu distributor for service.

CLEAN HYDRAULIC TANK STRAINER**WARNING**

- The parts and oil are at high temperature immediately after the engine is stopped, and may cause burns. Wait for the temperature to go down before starting the work.
- When removing the oil filler cap, turn it slowly to release the internal pressure, then remove it.

1. Remove 4 bolts, then remove cover (1). When doing this, cover (1) may fly off because of the force of spring (2), so keep the cover pushed down when removing the bolts.
2. Hold the top of rod (3) and pull up to remove spring (2) and strainer (4).
3. Remove any dirt stuck to strainer (4), then wash it in clean diesel oil or flushing oil. If strainer (4) is damaged, replace it with a new part.
4. When installing, insert strainer (4) into protruding part (5) of the tank, and assemble.
5. Install cover (1) with bolts.

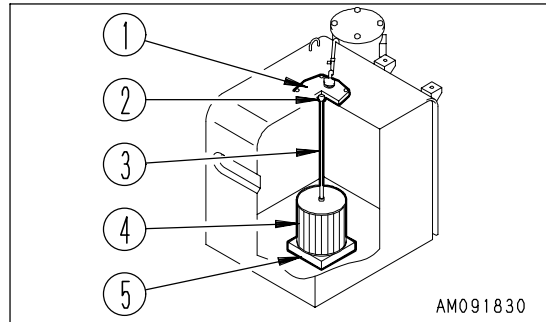
**CLEAN ENGINE BREATHER****WARNING**

- The parts and oil are at high temperature after the engine is stopped, and may cause serious burns. Wait for the temperature to go down before cleaning the engine breather.
- When using compressed air, there is a hazard that dirt may be blown up and cause serious injury. Always use safety glasses, dust mask, or other protective equipment.

1. Wipe away dust around the breather.
2. Loosen the clamp and remove the hose. Remove breather (1).
3. Clean the breather body with light oil or cleaning oil.
4. Replace O-ring with new one. Coat a new O-ring with engine oil, set it, then install breather (1).
5. Check the breather hose and pipe. If caked oil (sludge) adhere to insides, replace the hose and pipe with new parts.

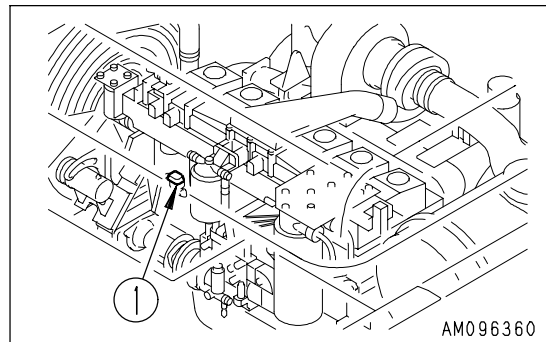
**CLEAN, CHECK TURBOCHARGER**

Contact your Komatsu distributor for cleaning and inspection.

EVERY 4000 HOURS SERVICE

Carry out the periodic maintenance work of every 100,250, 500, 1000 and 2000 hours of operation at the same time.

CHECK WATER PUMP

Check the pulley for play and water leakage. If anything unusual is found, ask the Komatsu distributor in your territory for the overhaul or replacement.

EVERY 5000 HOURS SERVICE

Carry out the periodic maintenance work of every 100, 250, 500 and 1000 hours of operation at the same time.

CHANGE OIL IN HYDRAULIC TANK AND CLEAN STRAINER



WARNING

- The parts and oil are at high temperature immediately after the engine is stopped, and may cause burns. Wait for the temperature to go down before starting the work.
- When removing the oil filler cap, turn it slowly to release the internal pressure, then remove it.

- A container of capacity over 270 liters (71.33 US gal) to receive drained oil
- Replacement amount of oil 270 liters (71.33 US gal)
- Prepare a handle (for the socket wrench).

1. Remove the cap of oil filler port (F) at the top of the hydraulic tank.

2. Set a container direct under the drain plug located on the machine's underside to catch oil that is drained. Remove drain plug (P) and drain the oil. Check an O-ring installed to Plug (P), and if it has a scratch or damage, replace it with new one. After draining the oil, tighten drain plug (P).

- The specified tightening torque is 68.6 ± 9.81 N·m (7 ± 1 kgf·m, 50.6 ± 7.2 lbft)
- Take care not to get oil on yourself when you remove drain plug (P).

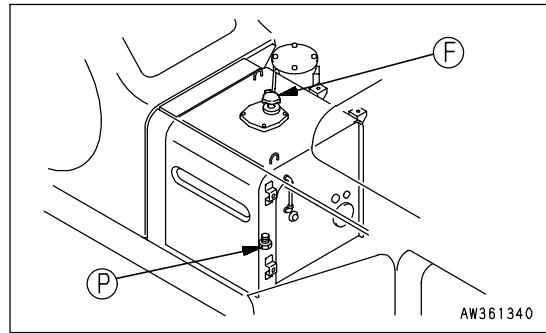

3. Add the specified amount of new and clean engine oil (for hydraulic system) through oil filler port (F). Check that the oil level is between H and L on the sight gauge.

For an oil level checking method, refer to the section of "CHECK OIL LEVEL IN HYDRAULIC TANK, ADD OIL (PAGE 3-39)".

AIR BLEEDING PROCEDURE

Bleed air from the hydraulic tank following the procedures explained below.

BLEEDING AIR FROM MAIN PUMP

For details, see "STARTING ENGINE (PAGE 3-49)". If it is necessary to refer to the items for starting the engine, moving the machine off, steering, or stopping, see the OPERATION section.

1. Bleeding air from pump

- 1) Loosen air bleed plug (1) and check that oil oozes out from the air bleeder.
- 2) If no oil oozes out, remove the drain hose from the pump case, and add hydraulic oil through drain port (2) to fill the pump case.

Oil will come out when the drain hose is removed, so secure the hose mouthpiece at a position higher than the level of the oil in the hydraulic tank.

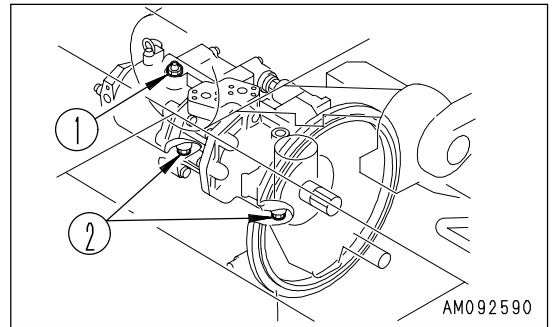

- 3) After completing the air bleed operation, tighten air bleed plug (1) and install the drain hose.

NOTICE

If the drain hose is installed first, oil will spurt out from plug hole (1).

If the pump is operated without filling the pump case with hydraulic oil, abnormal heat will be generated and this may cause an unexpected damage to the pump.

STARTING ENGINE

Start the engine, referring to the section of "STARTING ENGINE (PAGE 3-49)". Hold the engine speed at low idling (MIN) for the initial ten minutes and then proceed to the next work.

BLEEDING AIR FROM CRUSHER MOTOR

1. Run the engine at low idling, then loosen drain hose (1) and check that oil seeps out from drain hose (1).
2. If oil does not seep out, stop the engine and disconnect drain hose (1), and fill the crusher motor case with hydraulic oil.
3. After completing air bleeding, connect drain hose (1).
4. Idle the engine at low speed to keep slow revolution.

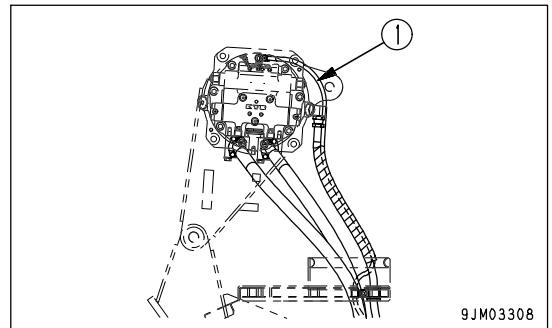
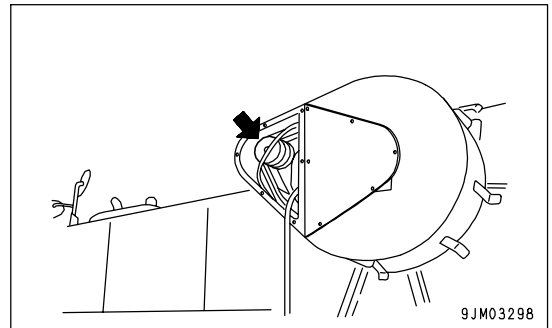

BLEEDING AIR FROM GRIZZLY FEEDER MOTOR

1. Run the engine at low idling, then loosen drain hose (1) and check that oil seeps out from drain hose (1).
2. If oil does not seep out, stop the engine, then disconnect drain hose (1) and fill the motor case with hydraulic oil.
3. After completing air bleeding, connect drain hose (1).
4. Idle the engine at low speed to keep slow revolution.

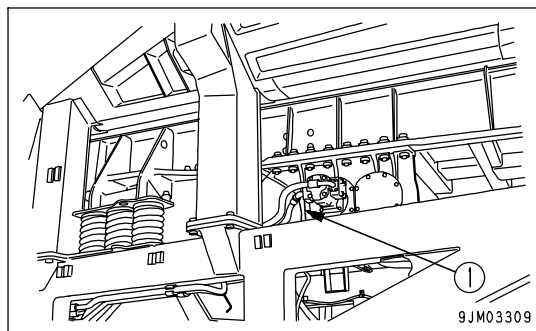
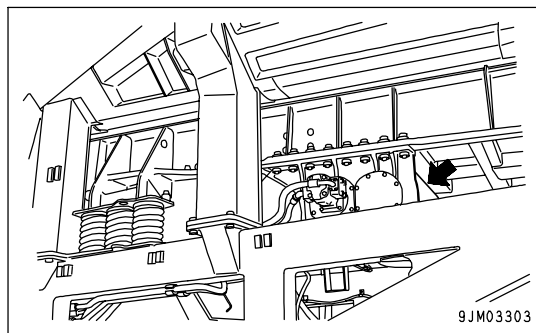

BLEEDING AIR FROM CONVEYOR MOTOR

NOTICE

For replacing oil in the conveyor motor machinery case, prepare a suitable scaffold for safety and commence the work.

[AGL height of conveyor motor machinery case: 3.0 m (9 ft 10 in)]

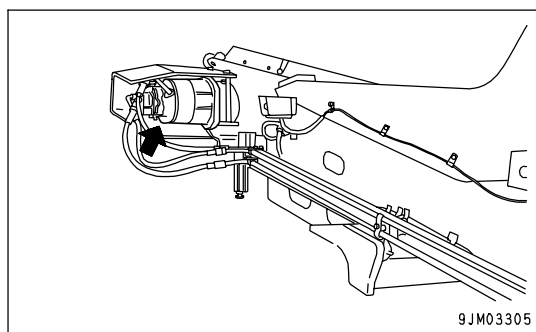

1. Idle the engine at low speed and loosen drain hose (1) at the connecting port. Then check that oil seeps out from drain hose (1).
2. If oil does not seeps out, stop the engine, then disconnect the connecting port and fill the crusher motor case with hydraulic oil.
3. After completing air bleeding, connect drain hose (1).
4. Idle the engine at low speed to keep slow revolution.

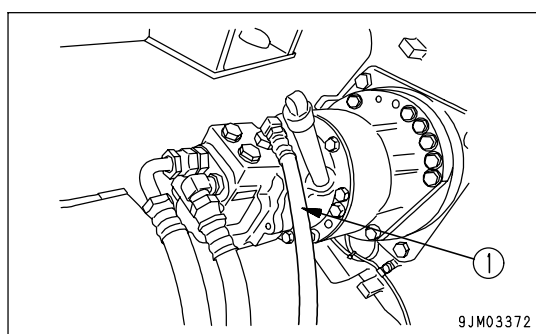

BLEEDING AIR FROM TRAVELING MOTOR

(Bleed the air only when the oil inside the travel motor case has been drained.)

- 1) Run the engine at low idling, loosen air bleeder (1), and check that oil flows out.

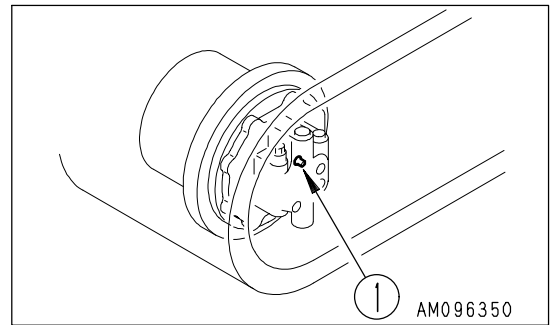
**OPERATION**

After completing air bleeding, stop the engine. Wait for more than five minutes before starting a work.

Air bubbles will be purged from the oil in the hydraulic oil tank this way.

SPECIFICATIONS

SPECIFICATIONS

Items	Unit	BR550JG-1	
Weight			
Overall machine weight (including fuel and cooling water)	kg (lb)	45000 (99225)	
Dimensions			
A	Overall length	mm (ft in)	13440 (44'1')
	Overall length [with opening-closing type hopper installed]	mm (ft in)	13430 (44'1")
	Overall length (in transport)	mm (ft in)	11985 (39'4")
B	Overall height	mm (ft in)	3670 (12'0")
	Overall height (in transport)	mm (ft in)	3380 (11'1")
C	Overall width (in transport)	mm (ft in)	2995 (9'10")
D	Track shoe width	mm (ft in)	500 (1'8")
E	Track gauge	mm (ft in)	2480 (8'2")
F	Track length on ground	mm (ft in)	3700 (12'2")
Engine			
Name	-	SAA6D125E-2	
Type	-	Direct injection + turbocharger + aftercooler	
Rated horsepower	kw(HP/rpm)	228(306/2050)	
Feeding device			
Method	-	Grizzly feeder with vibration controller	
Trough dimensions (width x length excluding grizzly bar)	mm (ft in)	1125 (3'8") x 3955 (12'12") [2050 (6'9")]	
Crusher			
Jaw crusher (Type)	-	FS4430-0A	
Weight	kg (lb)	17600 (38808)	
Primary belt conveyor			
Belt (width x length)	mm (ft in)	1050 (3'5") x 10135 (23'3")	
Belt rotating speed	m/min	120	
Hopper			
Capacity (including top of grizzly bar)	m ³ (cu.yd)	6.0 (7.8)	
Type	-	Fixed type (foldable type)	
Performance			
Dimensions of max. crushable debris	mm (ft in)	600 (1'12") x 600 (1'12") x 600 (1'12") (natural stone) 1200 (3'11") x 950 (3'1") x 600 (1'12") (concrete debris)	
Travel speed	km/h (MPH)	1.8 (1.1)/3.0 (1.9)	
Gradeability	Degree	25	
Drive			
Travel drive method	-	Hydraulic type	
Crusher drive method	-	Hydraulic type	
Capacity			
Fuel tank	liter (US gal)	555 (146.63)	
Hydraulic oil tank	liter (US gal)	358 (94.58)	

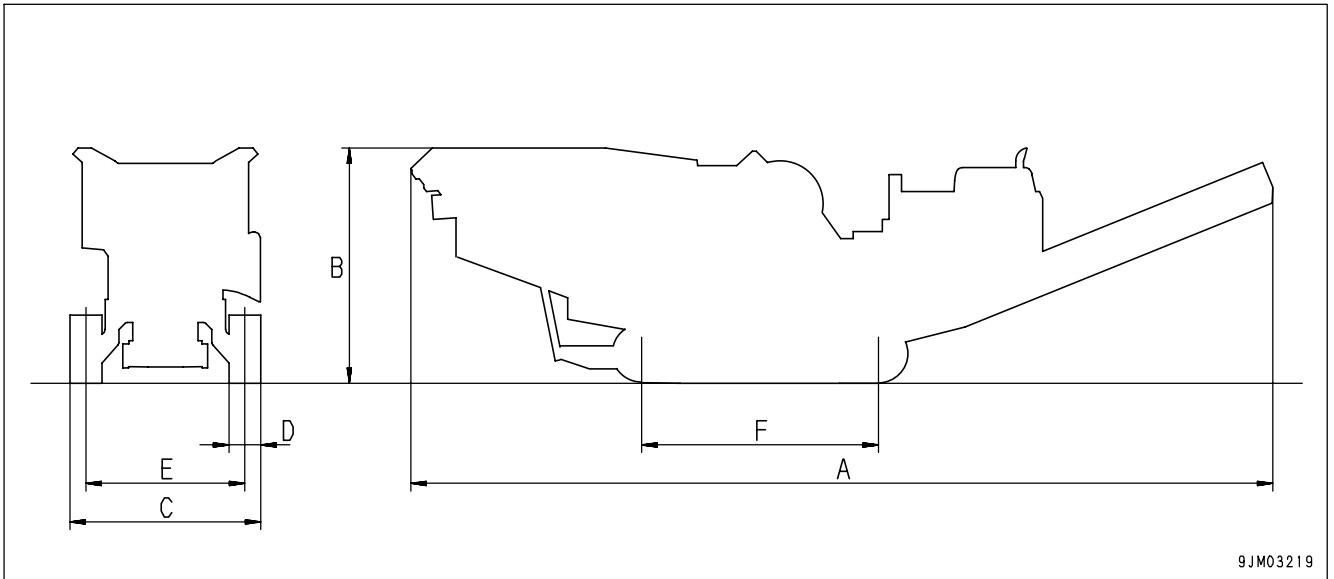

ATTACHMENTS, OPTIONS

WARNING

Please read and make sure that you understand the SAFETY section before reading this section.

GENERAL PRECAUTIONS

PRECAUTIONS RELATED TO SAFETY



WARNING

A crane ought to be operated only by a licensed operator. Do not allow an operator without such license.

NOTICE

For detail on the works of installing and dismantling attachments, consult the Komatsu distributor in your territory.

If attachments or options other than those authorized by Komatsu are installed, this will not only affect the life of the machine, but will also cause problems with safety.

When installing attachments not listed in this Operation and Maintenance Manual, contact your Komatsu distributor first.

If you do not contact Komatsu, we cannot accept any responsibility for any accidents or failures.



WARNING

Precautions for dismantling and installation

When dismantling or installing attachments, observe the following precautions for safety work.

- Carry out dismantling and installation works on the flat and solid ground.
- When a work is carried out by two workers or more, decide signals and let them obey the signals while working.
- Use a crane for removing a heavy item (over 25 kg (55 lb)).
- When detaching a heavy parts, be sure to prepare for a support beforehand.
Furthermore, when lifting up a heavy item with a crane, pay a special attention to the position of the center of gravity.
- It is dangerous to proceed with the work with a heavy item hung up in the air with a crane. Be sure to provide a stand and lower the heavy item on it to ensure safety during the work.
- When leaving any attachment as detached or installing it, let it stand or hold it securely.
- Do not go under a heavy item that is hung up in the air with a crane.
Keep well clear of a hung item and stay in a safe position to avoid an injury, should it fall off.

HYDRAULIC TYPE MAGNETIC SELECTOR

[Example for application]

This attachment is used for removing reinforcing bars contained in reinforced concrete.

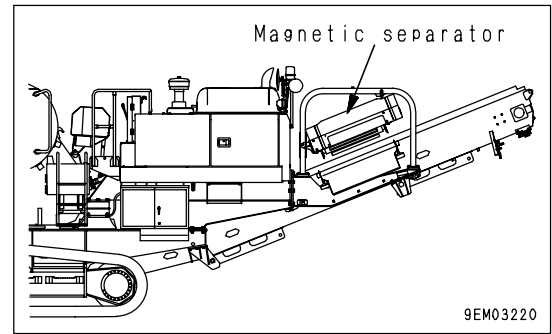

SAFETY PRECAUTIONS



WARNING

- Do not get close to the magnetic separator with precision instruments like a wrist watch, measurement tool, etc. It is very dangerous for somebody to come near the magnetic separator with metal pieces, because the magnetic separator attracts him/her to it.
- Anybody with a pace maker on is warned against getting close to the magnetic separator, because the pace maker may make an erratic movement.
- Do not bring a credit card or the like close to the magnetic separator. The memory contained in the card may be disrupted by strong magnetism.



CAUTION

- When conduction a trial run of the machine, be sure to run the motor at low speed and check that the conveyor belt does not make a snaky movement.
- If metal pieces are drawn by the magnetic separator, they will be ejected, accelerated by the metal piece discharging belt. As that poses a big danger, provide a safety cover at the discharging outlet to prevent the metal pieces from flying off.

PROCEDURES FOR CONNECTION WITH CRUSHER

Refer to the section of "PROCEDURES FOR CONNECTING OPTIONAL ATTACHMENTS (PAGE 6-27)" in this manual.

PRECAUTIONS IN USE

- Set the belt conveyor and the magnetic selector in parallel, when using both of them simultaneously.
- The standard clearance between the conveyor belt surface and the magnetic selector is 350 mm (13.8 in). Adjust it as appropriate, depending on the crusher outlet clearance or any other related factor.

CHECK AND INSPECTION

The discharging belt for this machine has the same structure as that for the conventional belt conveyor. Pay attention to the following points, when starting the day's work or daily inspection.

- Has the belt been biased or does it make a snaky movement?
- Is the belt tension appropriate?
- Are debris stuck to the backside of the belt?
- Has the belt surface been scratched or peeled off?
- Has the belt scraper not been damaged?
- Have metal parts or bolts at the connection of the belt end not been damaged or fallen off?

If anything unusual is found, take the following actions.

- 1) In case the belt is deflected or makes a snaky movement; Adjust the position of the take-up unit, referring to the figure at right. The take-up unit consists of a base plate, a pillow block and a tap bolt. Loosen the lock bolt on the base plate and adjust the position of the take-up unit with the tap bolt. After the adjustment, tighten the lock bolt again. When there is a clearance more than 10 mm (0.4 in) at both ends from the inner surface of the flange at the end of the pulley, the belt is at a proper position.
- 2) In case the belt tension is not appropriate; Adjust the belt tension in the same way as mentioned above. At that time, adjust the belt so that it will have a clearance of 30 to 40 mm (1.2 to 1.6 in) from the lower surface of the magnet on the main body.
- 3) In case debris are stuck at the backside of the belt; Remove them as soon as found, since they can cause a damage on the belt or the pulley.
- 4) In case the belt or any other relative parts is damaged; Replace it with new one promptly.

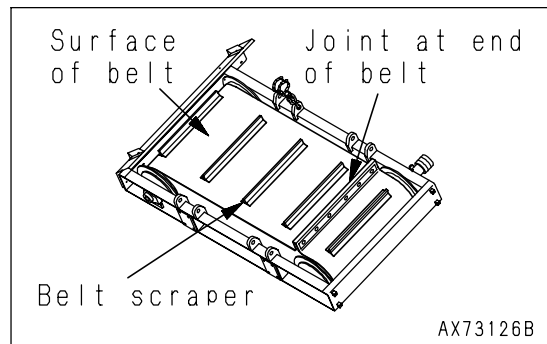
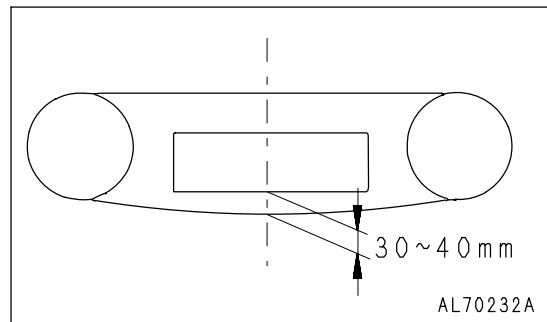
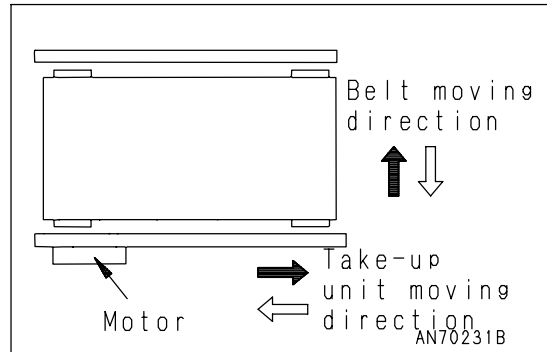

FAILURES AND CORRECTIVE ACTIONS

Failure Mode	Cause	Corrective Action
Abnormal sound from bearings	Seizure of bearing Loosened mounting bolts	Replace bearing. Retighten bolts.
Snaky movement of belt	Improper adjustment of pulley Materilas stuck in belt	Adjust pulley position with take-up bolt. Remove foreign objects.
Breakage of belt Perforation	wear, fatigue or attraction of metal pieces on attractive surface	Remove metal pieces. Replace belt with new one, depending on hole size and degree of wear.
Damage on scraper		Replace with new one.

LIST OF CHECKPOINT

Checkpoint	Daily Check	Every Month	Every 3 Months	Every 6 Months	Every Year
Damage on metal piece discharging belt	○				
Snaky movement and loosening of belt	○				
Loosening of each clamping bolt				○	○
Abnormal sound from bearings	○				

SPECIFICATIONS

(KMG900S)

- Type: KMG900S (62A-HPK903B)
- Belt rotating speed: 95 m/min.
- Conveyor belt width: 700 mm
- Driving method: Hydraulic gear motor
- Weight: 900 kg (1985 lb)

(KMG900L)

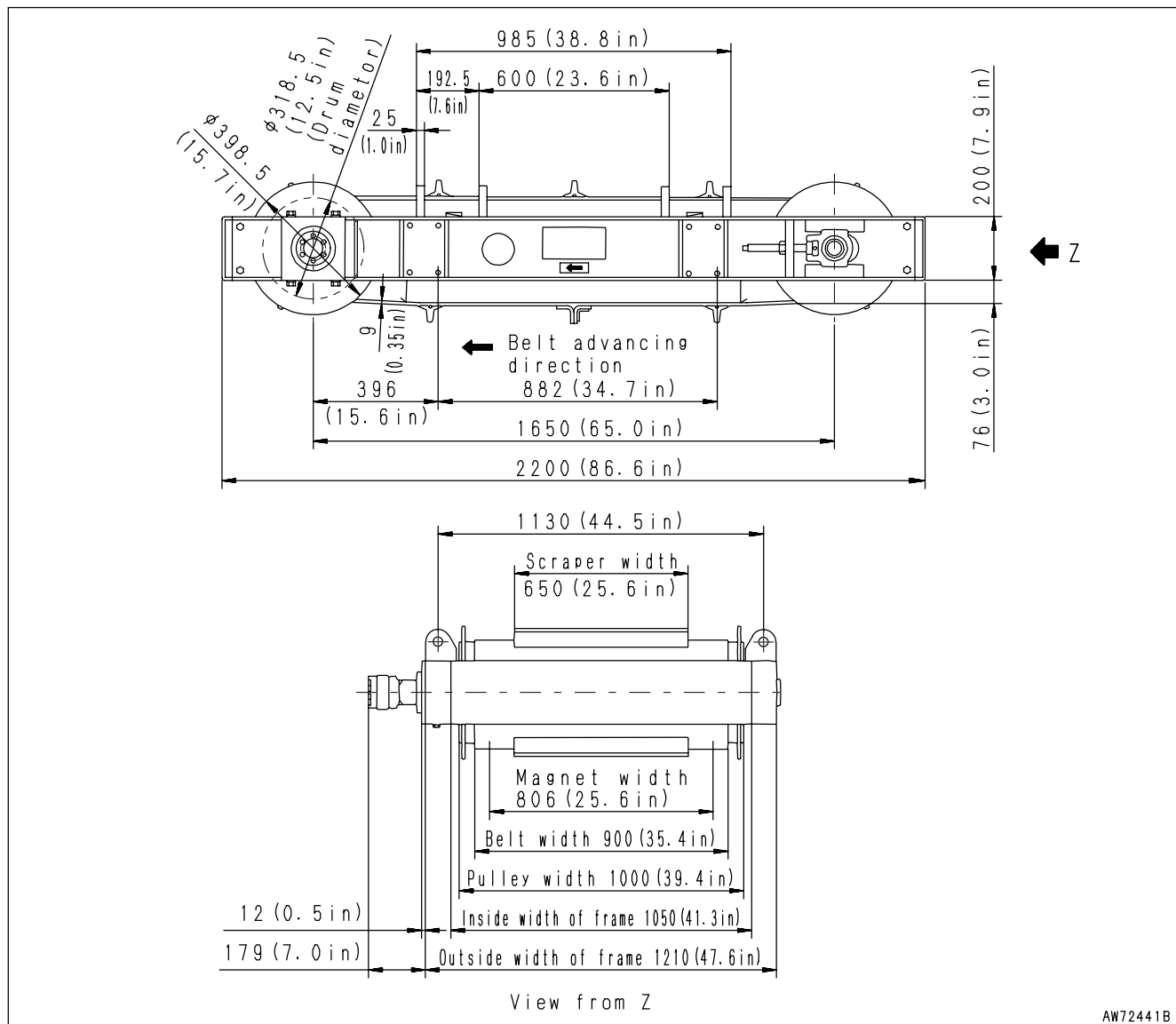

LIST OF WEARING PARTS

No.	Part Name	Part No.	Q'ty	Remarks
		8295-78-1100	1	
6	Pulley	MFK0000091	1	Pulley on drivenside
7	Bearing	MFK0000101	2	
11	Motor	8295-60-1130	1	Sumitomo Eaton (393cc/rev) 2-390AS2-E3779
18	Bearing	MFK0000291	1	On driving side
19	Bearing	MFK0000301	1	On driven side
23	Belt	MFK0000401	1	Ultra wear-resistant conveyor belt (500kgf/cm) Width 900 mm x overall thickness 11.8t
	Scraper	MFK0000411	8	Rubber lug
24	Bar	MFK0000421	2	Belt connecting part t5(SUS304)
25	Bolt	MFK0000431	7	Belt connecting part M12 x 60 (SUS304)
26	Nut	MFK0000441	14	Belt connecting part M12 (SUS304)
27	Washer, Spring	MFF0000451	7	Belt connecting part M12 (SUS304)
32	Pulley	MFK0000511	1	Pulley on driving side SPG300A

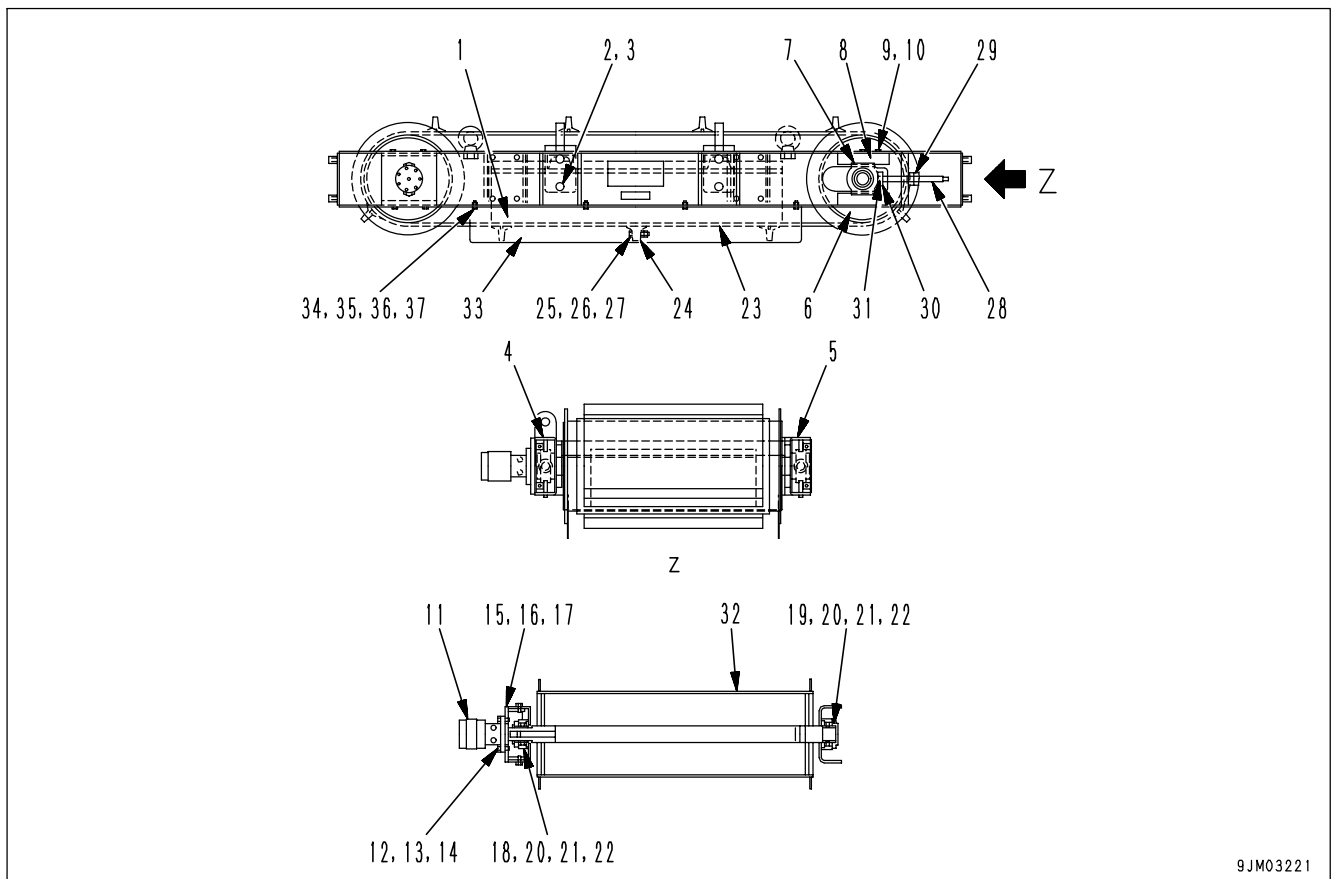

9JM03221

MUCK DISCHARGE CONVEYOR

LIFTING PROCEDURES

- Prepare a wire rope (1) for lifting and fasten the rope end to the conveyor at bracket (A) with a shackle.
- Since the center of gravity of the debris discharging conveyor is at position (A), two point lifting is possible. It is recommended, however, to lift it at four points fixing another wire rope (2) to position (B), too, until the conveyor is inserted into hopper frame (3).
- When the belt conveyor is hung up in the air, move it as slowly as possible.
In addition, never go under the hung belt conveyor.

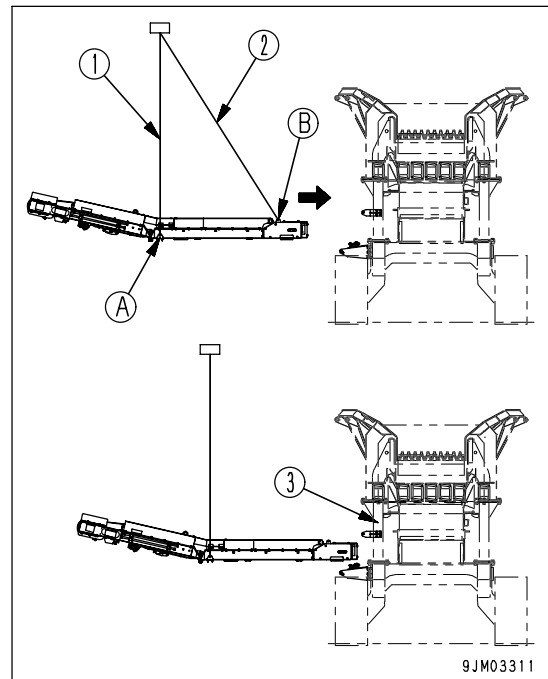

ASSEMBLING PROCEDURES

1. Install a hydraulic cylinder, a hydraulic cylinder bracket and an in-transport conveyor fixing bracket on the side of the machine where the debris discharging conveyor is inserted.

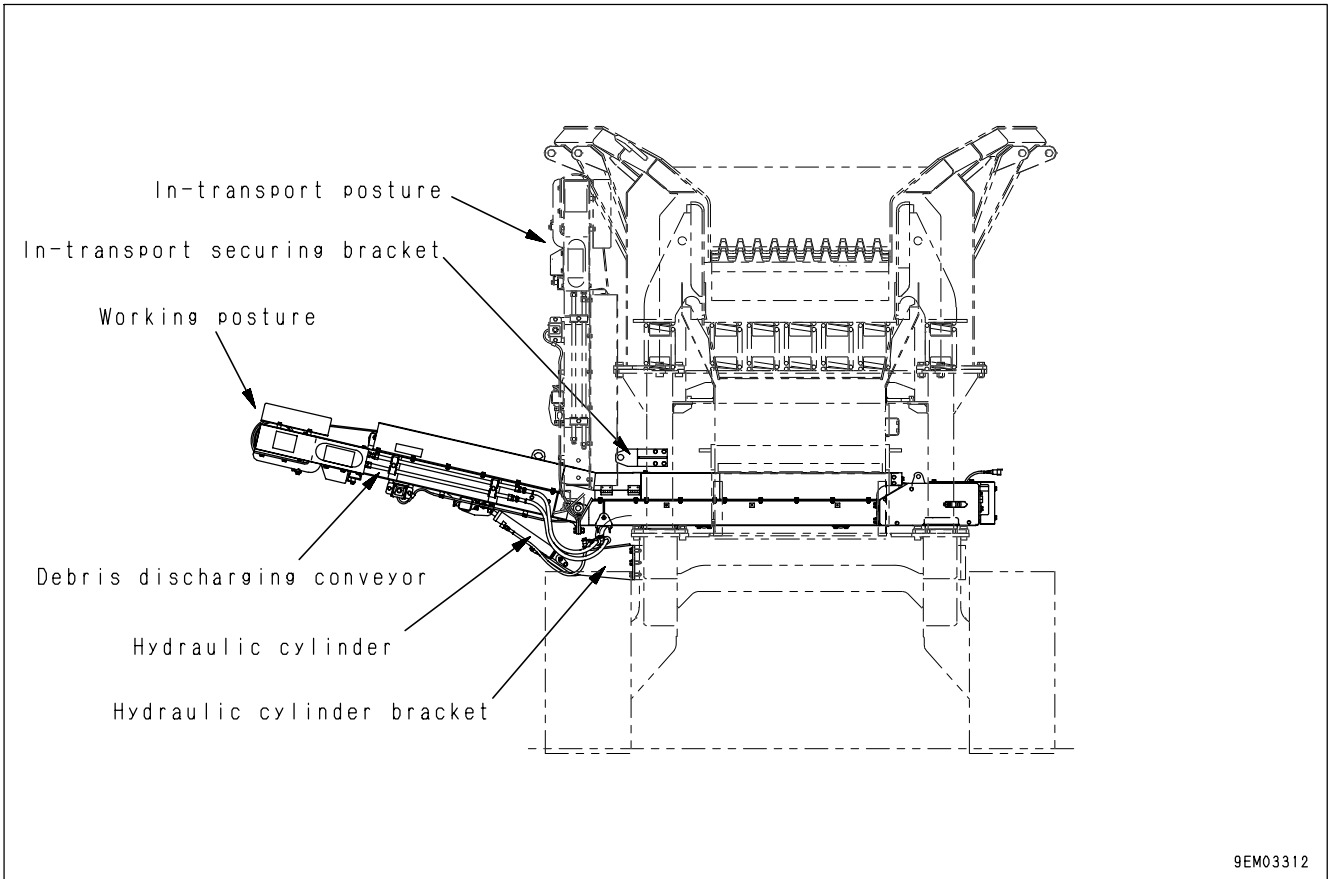

DISMANTLING

PROCEDURES FOR INSTALLING HYDRAULIC CYLINDER

1. Insert pin (1) at the cylinder bottom for the connection.

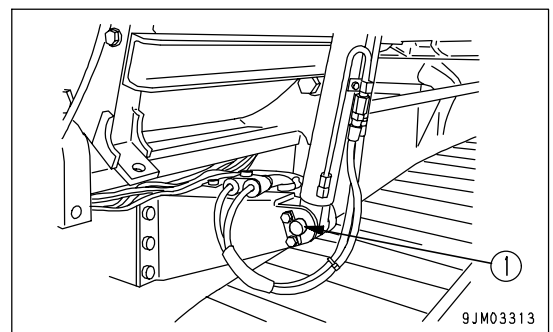

- Following the instructions for lifting the belt conveyor, tuck away the debris discharging conveyor in the hopper frame, and secure the belt conveyor frame on the track frame.
(Securing bolt (2): M16 x 8 bolts)

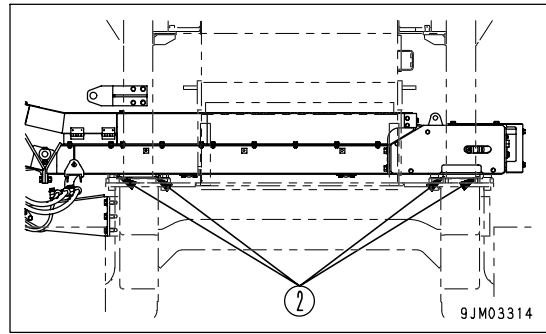

- Insert pin (3) at the hydraulic cylinder head to connect with the debris discharging belt conveyor.

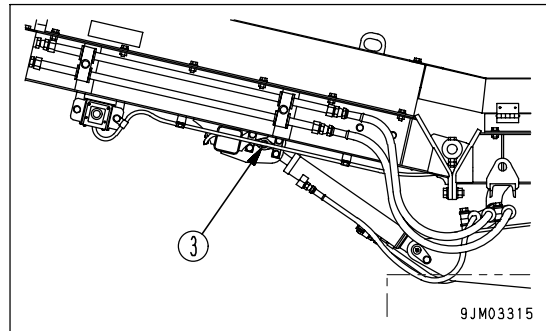

- Connect with the machine piping for the hydraulic cylinder and belt conveyor as well as an electric circuit for emergency stop.

PROCEDURES FOR FOLDING DEBRIS DISCHARGING CONVEYOR

- Remove conveyor frame connecting bolts (1).
(M16 x 2 bolts)
- Remove side cover securing bolts (2) at the conveyor center and fold up the side cover.
(M10 x 4 bolts)

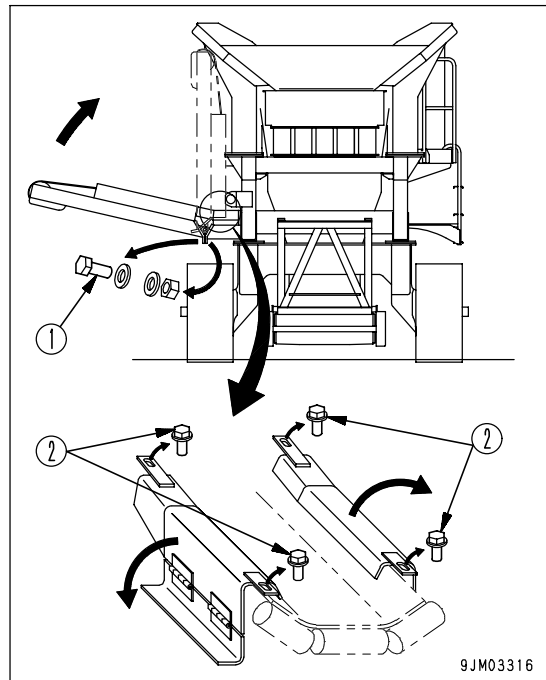

3. Start the engine.
4. Depress debris discharging conveyor raising switch (3) to fold up the conveyor.

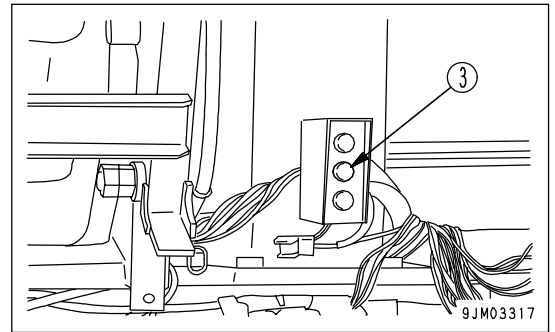

5. Insert a pin into the in-transport conveyor fixing bracket to secure the conveyor.
6. Stop the engine.

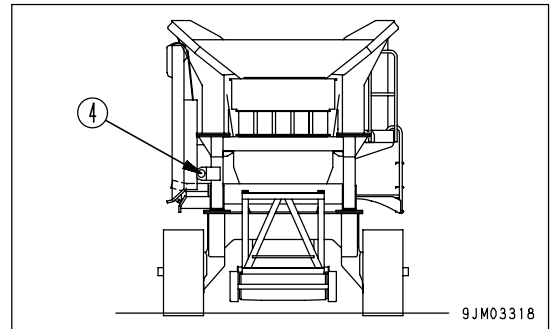

GREASING MUCK DISCHARGE CONVEYOR

NOTICE

Grease the muck discharge conveyor every 100 hours of operation.

1. Head pulley bearings (2 places)

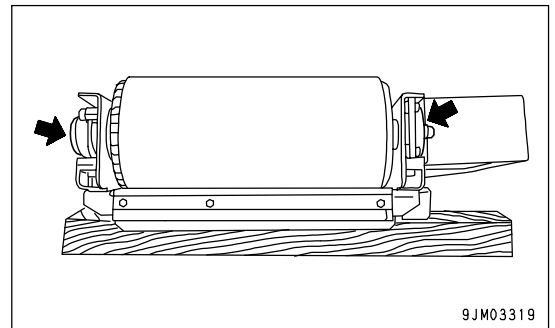

2. Tail pulley bearings (2 places)

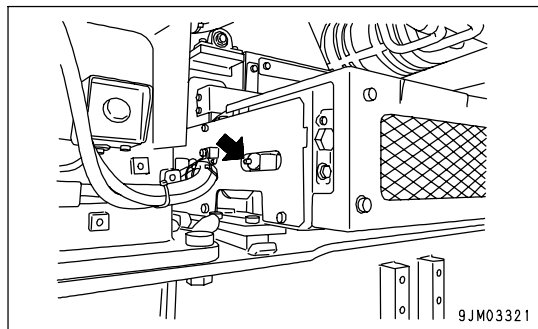
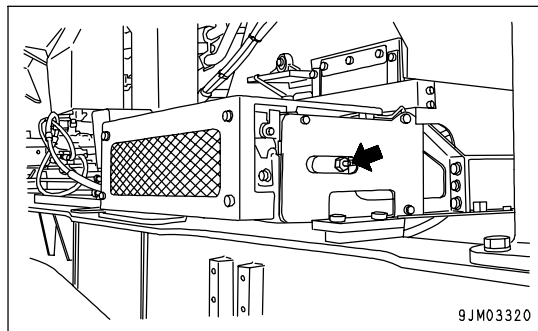

CHECK AND ADJUSTMENT OF MUCK DISCHARGE CONVEYOR

 **WARNING**

There is always the danger that you get caught in the revolving parts of the conveyor, while inspecting or cleaning it. Be sure to stop the engine before starting the work.

IS THE BELT NOT SLACKENED?

 **CAUTION**

Stop the engine first and start to work on the adjusting bolt (1).

If the conveyor belt is slackened, it tends to slip off and does not perform properly. Adjust the belt tension by turning the adjusting bolts on the right and left sides of the belt.

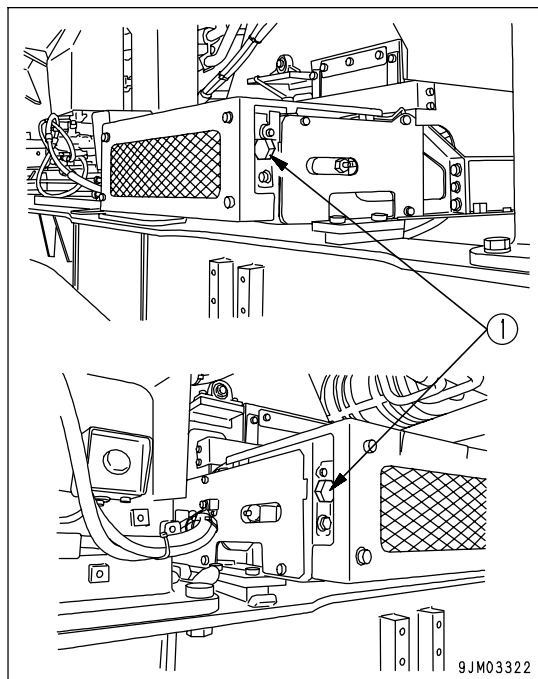

IS THE BELT NOT DEFLECTED?

1. When the belt is deflected to the left, move the belt in the direction indicated with an arrow.

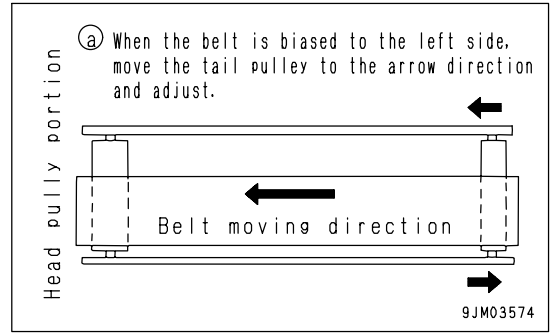

2. When the belt is deflected to the right, move the belt in the direction indicated with an arrow.

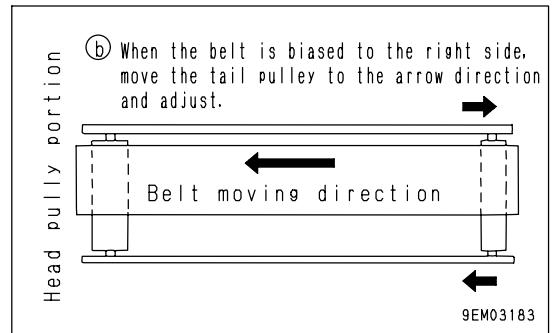

CHECK OF EACH PART IN BELT CONVEYOR FOR ANY STUCK FOREIGN OBJECT

Remove a stone, wire shred, gravel, etc. that are stuck at the backside of the belt conveyor, or in between the rollers and belt, or inside the hopper rubber and belt.

DO THE TAIL PULLEY AND ROLLERS TURN SMOOTHLY? OR IS THERE ANY PART IN THE BELT THAT IS ABOUT TO BREAK?

The conveyor belt may be damaged or broken while in operation. In that case, replace the defective belt with new one promptly.

1. Keep a close watch on the head scraper constantly.
Unless the scraper is in firm contact with the belt, earth stuck to the rollers will likely cause the rollers to wear prematurely.

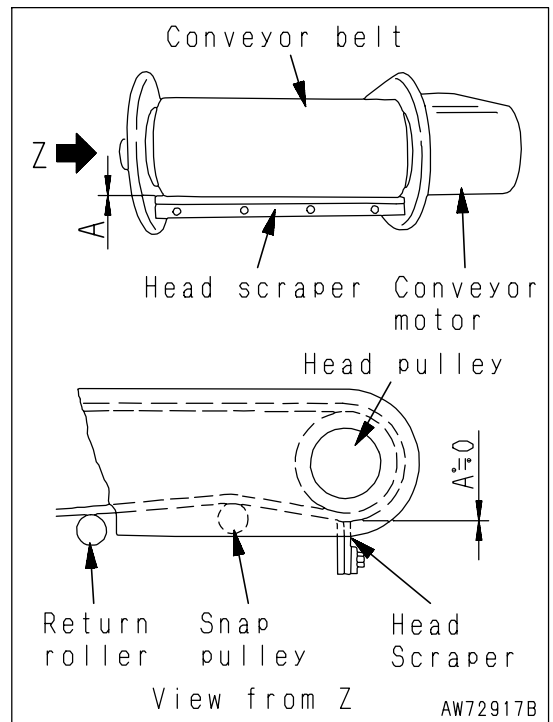

FAILURES AND CORRECTIVE ACTIONS

Abnormal Phenomenon	Major Cause	Corrective Action
Conveyor belt		
Not operable	<ul style="list-style-type: none"> • Electric circuit fault • Connection fault 	<ul style="list-style-type: none"> • Correct wiring. • Insert connection properly.
Snaky movement	<ul style="list-style-type: none"> • Misalignment of rollers and improper mounting • Debris transport direction • Debris stuck to rollers (Likewise wire or string winding about rollers) • Belt elongation • Belt bending, or not installed properly in endless processing • Frame twisting and bending • Frame not poised evenly (Belt is deflected to lower side) • Belt too rigid (Wrong belt chosen) 	<ul style="list-style-type: none"> • Adjust roller mounting angle. • Load debris evenly in the middle of the belt, after making sure that the machine is kept level on the ground. • Clean roller periphery. • Adjust belt tension with take-up. • Retry endless processing, or replace belt with new one. • Correct twisting and eccentricity at time of assembly or machine installation. • Correct twisting and eccentricity at time of assembly or machine installation. • a. Run in belt without load. • b. replace with softer (proper) belt.
Abnormal wear on backside	<ul style="list-style-type: none"> • Slip on motor pulley (or driving pulley) surface • Debris or foreign object stuck in between belt and pulley (Foreign objects stuck on pulley surface) • Faulty rotation of rollers 	<ul style="list-style-type: none"> • Correct belt elongation with take-up. • a. Remove foreign objects. (Remove sticking) • b. Improve loading conditions at loading part. • Replace faulty rollers.
Damage (fissure in vertical direction)	<ul style="list-style-type: none"> • Debris or foreign objects caught where belt contacts hopper, scraper, etc. • Rollers falling off from bracket and bracket coming to direct contact belt • Rollers of faulty rotation worn out and perforated • Shock due to drop of large and heavy mass • Edged debris 	<ul style="list-style-type: none"> • Remove foreign objects. • Insert rollers into bracket correctly. • Replace faulty rollers. • Devise to alleviate shock, or ensure right load. • Do not let such materials be transported.
Abnormal elongation	<ul style="list-style-type: none"> • Too strong take-up • Transport of hot materials • Abnormal load • End of service life 	<ul style="list-style-type: none"> • Return to normal tension. • Replace with heat-resistant belt. • Ensure proper load. • Replace with new belt.
Warping	<ul style="list-style-type: none"> • Oily debris (Warping to lower cover side) • Transport of hot materials • Acid content or alkali content included in debris 	<ul style="list-style-type: none"> • Remove cause for oil to mix with debris, or use oil-resistant belt. • Use heat-resistant belt. • Use acid-resistant or alkali-resistant belt.

Abnormal Phenomenon	Major Cause	Corrective Action
Scraper belt		
Wear and damage	<ul style="list-style-type: none"> • Debris caught 	<ul style="list-style-type: none"> • a. Remove caught-in debris and correct scraper rubber mounting so as to evenly contact belt. • b. Replace with new one.
Rollers		
Abnormal sound Breakage	<ul style="list-style-type: none"> • Faulty rotation of rollers • Wire or string winding about shafts Shock due to fall of large and heavy mass 	<ul style="list-style-type: none"> • Replace with new one. • Remove foreign objects. Take measures to ensure proper lump size and weight to alleviate shock.
Motor		
Faulty operation	<ul style="list-style-type: none"> • Insufficient hydraulic oil 	<ul style="list-style-type: none"> • a. Add oil up to specified level. • b. Replace or repair.

WEARING PARTS

No.	Part Name	Part No.	Q'ty	Unit Weight [kg (lb)]
1	Conveyor belt	Not to be supplied as single part. Refer to following specifications.		
2	Bearing unit	8221-75-2510	1	1.69 (3.73)
3	Bearing	8248-75-4250	1	0.55 (1.21)
4	Belt cleaner	8295-75-5530	1	0.36 (0.79)
5	Carrier roller	8206-75-3850	12	1.60 (3.53)
6	Rubber	8295-75-5161	2	0.70 (1.54)
7	Return roller	8206-75-3860	4	4.90 (10.80)
8	Rubber	8295-75-5211	2	0.31 (0.68)
9	Rubber	8295-75-5261	2	0.29 (0.64)
10	Impact carrier roller	8295-75-5470	15	1.80 (3.94)
11	Rubber	8295-75-5311	2	0.65 (1.43)
12	Rubber	8295-75-5341	1	0.55 (1.21)
13	Bearing	06300-06207	2	-
14	Scraper rubber	8221-75-2550	1	0.32 (0.71)

Conveyor belt specification

Size	Width	600 mm (1 ft 12 in)		
	Length of endless	8620 mm (28 ft 3 in)		
Belt strength		250kg/cm		
No. of ply		2	1	
Core material		Polyester	Nylon, polyester	Nylon
Cover rubber thickness (front x rear)		5.0mm x 1.5mm (0.197 in x 0.059 in)		
Overall thickness (for reference only)		8.4 mm (0.331 in)	8.2 mm (0.323 in)	

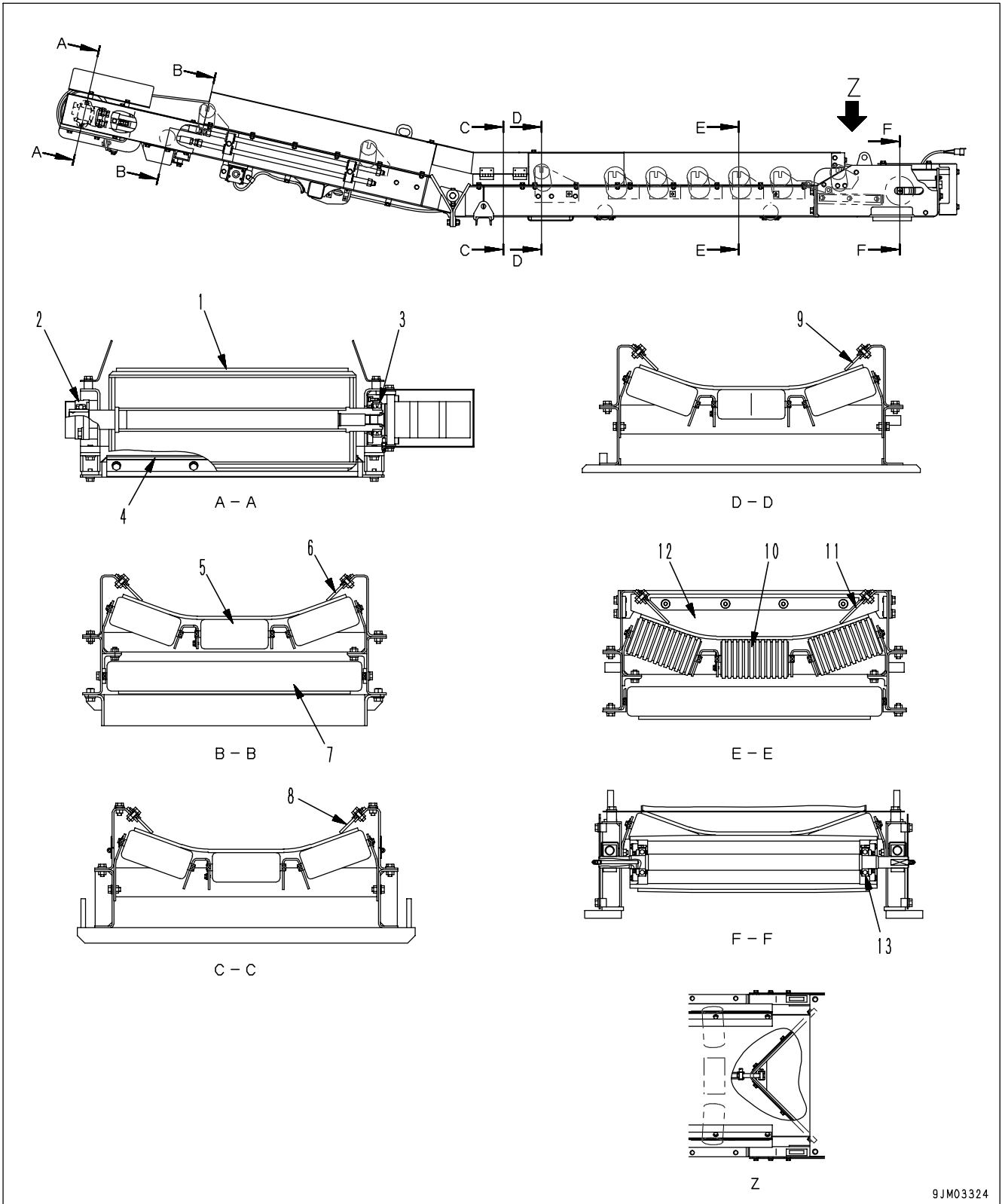

9JM03324

SPECIFICATIONS

Komatsu Part No.		8295-75-5000
Belt width x machine length		60 cm x 4 m (1 ft 12 in x 13 ft 1 in)
Max. gradeability	degree	13
Motor rotation	rpm	153
Belt travel speed	m/min	130
weight	kg (lb)	533 (739)

RADIO CONTROL UNIT

When using the radio control unit, set the radio control unit selector switch in the main control box to the ON position.

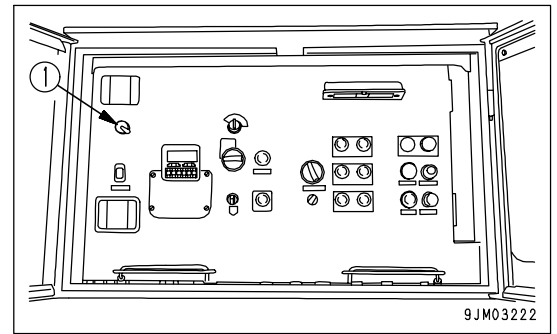

DIRECTIONS FOR USE

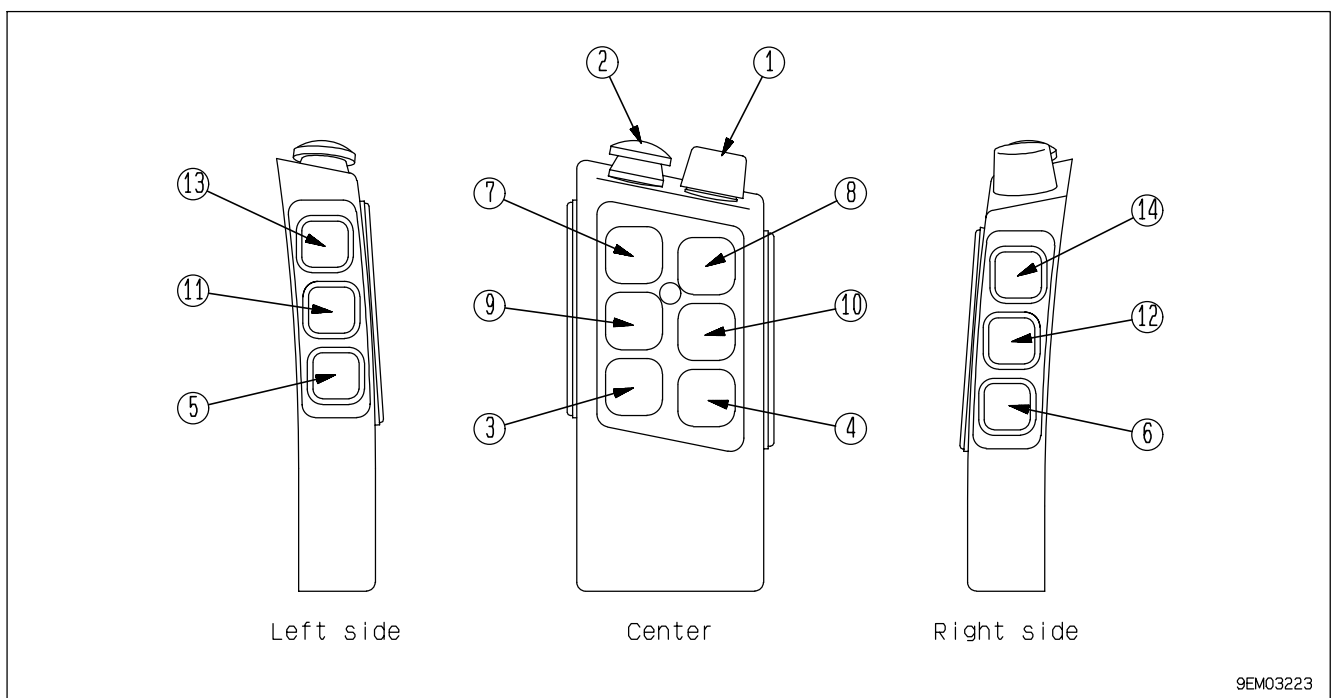

- | | |
|-----------------------|------------------|
| (1) POWER | (8) R-FORWARD |
| (2) TRANSMISSION STOP | (9) L-BACK |
| (3) HORN | (10) R-BACK |
| (4) STOP | (11) FEEDER ON |
| (5) ACCEL | (12) FEEDER OFF |
| (6) DECEL | (13) CRUSHER ON |
| (7) L-FORWARD | (14) CRUSHER OFF |

SWITCH

NOTICE

The following switches may be operated by setting the operation mode selector switch to the TRAVEL position.

- (1) TRANSMISSION STOP

When this switch is depressed, the radio control unit does not transmit any wave of any mode.

Be careful not to depress it by accident, since the work equipment can be neither started nor stopped in that case.

(2) POWER

When this switch is turned to the right, the radio control unit is switched on.

A radio-controlled machine operation is ready, when the radio control selector switch in the main control box is set to the ON position and the revolving working lamp on the machine (blue) is switched on.

(3) HORN

When depressed, this switch sounds a horn.

(4) STOP

When depressed, this switch stops all the work equipment.

(5) ACCEL

When depressed, this switch releases the deceleration switch, raising the engine revolution to the maximum at one touch.

(6) DECEL

When depressed, this switch reduces the engine revolution to the deceleration speed (approx. 1400 rpm) at one touch.

TRAVELING**CAUTION**

When the machine travels under the radio control, the travel speed is regulated to 1.8 km/h (1.1 MPH) for a safety reason.

NOTICE

The following switches may be operated by setting the operation mode selector switch to the TRAVEL position.

(7) L-FORWARD

When this switch is depressed, the machine travels forward to the left side.

(8) R-FORWARD

When this switch is depressed, the machine travels forward to the right side.

(9) L-BACK

When this switch is depressed, the machine travels backward to the left side.

(10) R-BACK

When this switch is depressed, the machine travels backward to the right side.

CRUSHING WORK**NOTICE**

The following switches may be operated by setting the operation mode selector switch in the main control box to the WORK position.

(11) FEEDER ON

When depressed, this switch sets the grizzly feeder in motion.

(12) FEEDER OFF

When depressed, this switch stops the grizzly feeder.

(13) CRUSHER ON

When depressed, this switch sets the crusher in motion.

(14) CRUSHER OFF

When depressed, this switch stops the crusher.

OVERVIEW

This radio control unit has the following features.

- The transmitter is of a handy type, powered by rechargeable nickel cadmium batteries. It is a wireless controller, enabling an operator to control the machine at any desired point at the worksite.
- The transmission output is 10mW.
- The transmission range is approx. 100 m (328 ft 1 in), if there is no electrical interference or obstacle. The actual range may vary, depending on whether the receiver antenna is properly installed, or on surrounding conditions like noises from neighboring plants.
- This unit is so designed as to turn off transmission output by virtue of various safety circuits in place and stop all the work, when receiving jamming waves or noises.

Depending on a country, a permit for a small-sized radio station may be required to use this unit, and then users may be required to observe the following.

- If a permit label is affixed to the radio control unit, do not peel it off, because any unit without the label may forfeit the permit, rendering it null and void.
- Never do any of the following, because such an action may violate the existing radio law in the country of use.
 - To open the remote controller box
 - To modify the remote controller
 - To modify the transmitter antenna
- Should the radio control unit be broken down, or the permit label be missing (if applicable), consult the Komatsu distributor in your territory.

ON USE OF RADIO CONTROL UNIT

SAFETY PRECAUTIONS WHEN USING RADIO CONTROL UNIT

Several electronic and mechanical safety devices are provided in this radio control unit. One of them is that, once a transmission code is set, it will not accept any signal for work from the other transmitter.

Please be reminded that depending on a wrong operation or use of the unit, there are always the following dangers.

- A machine operator or workers in the surrounding may be critically injured.
- Damages may be inflicted on the machine, its apparatus and materials fed into the machine.

This unit has to be operated only by a qualified person who has received a proper training and in accordance with the instructions for operation set forth in this manual.

FACTORS OF HAZARD

The machine can be remote-controlled using a wave in this system. A work instruction can be conveyed to the opposite side of an obstacle, or to a place where an operator cannot see. Hence observe the following.

- When leaving the radio controller away from an operator, be sure to turn POWER switch (1) off and pull out the key. Confirm then that the switch is at the OFF (0) position.
- When installing the unit somewhere, or when carrying out maintenance and repair works on the machine, be sure to turn the POWER switch of the unit to the OFF position.
- Never try to remove any of the safety devices in this unit nor modify any of them.

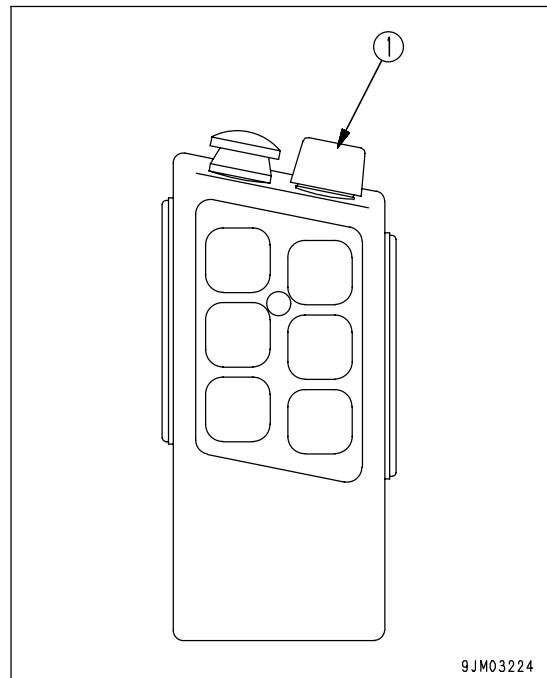

QUALIFICATIONS FOR UNIT OPERATOR

An operator of this unit is required to carefully read both operation manuals for the machine and the unit and thoroughly understand both operation methods. If the transmitter is left away from an operator, do not forget to remove the key. This practice is necessary to prevent someone from operating the transmitter carelessly.

The supervisor of operations using the unit, the machine owner and administrator have a responsibility to ensure that a unit operator has an easy access to the operation manuals, and to confirm that he/she reads them and understands all the contents.

ESTABLISHING SAFETY MEASURES AT WORKSITE

An operator is required to ensure safety at the work site where he/she uses the radio control unit. Make sure that there is no danger of slipping or tripping over something.

DEVICES PROVIDED FOR SAFETY PROTECTION

**WARNING**

Never remove any of the safety devices in the unit nor modify any for whatsoever reason.

**CAUTION**

While signal transmission is suspended, the work equipment can be neither started nor stopped. In order to stop the work equipment, turn Main/Remote selector switch (1) to the right, pull out the key for TRANSMISSION STOP switch (2), and then depress either the stop switch of each work equipment or STOP switch (3). Then transmission can be resumed.

The transmitter will stop transmission through either of the following methods. If transmission is topped, the revolving working lamp (blue) will be switched off.

- Depress TRANSMISSION STOP switch (2) located on top of the transmitter control panel.
- Set POWER switch (1) to the OFF position. (The transmitter stops transmission 450 ms after the switch is set to the OFF position)

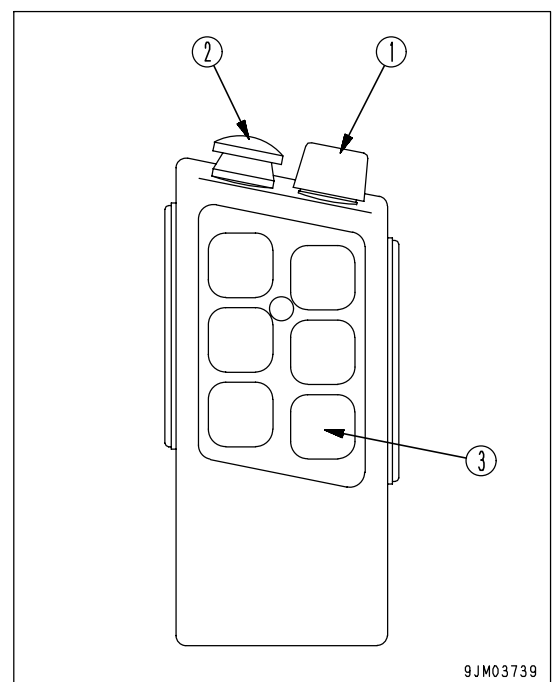
**ACTIONS IN CASE OF EMERGENCY**

Should any emergency take place, depress STOP switch (3).

Then take necessary actions, as the case may be, following the instructions set forth in the operation manual for the machine.

OPERATION**WARNING**

A machine operator must not use this radio control unit, until after he/she has carefully read this operation manual and completely understood the contents. Pay special attention to safety instructions mentioned in this manual.

INSTALLATION OF BATTERY

**WARNING**

There is a danger of EXPLOSION!

Use only a genuine battery made by Hetric Japan.

If a non-genuine battery is used, there is a possibility of explosion. An explosion will produce hazardous gases and cause splinters to fly off, inviting a bodily injury or death of the operator or the workers at the worksite.

Before using the radio control unit, connect one of the batteries with a battery charger to make sure that the battery is fully charged.

Battery installation method

NOTICE

A battery charger judges automatically that the batteries have been fully charged. When batteries are fully charged, the battery charger switches a charging mode to "light charging". Then the battery charger automatically begins to charge the batteries again, when they are fully or slightly discharged.

Before starting to use the transmitter, push the battery into the battery charger with the battery contact surface facing forward. Push the battery unit in lightly so that the batteries fit in well with the battery charger.

While the battery is charged, a green lamp on the battery charger is on, and when charging is finished the lamp begins to come on and off. When the second battery is installed in the battery charger, the fully charged batteries are ready for service.

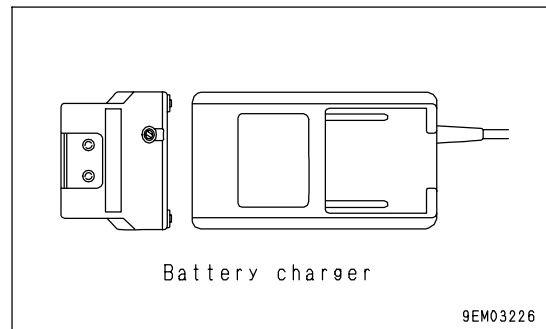

SAFETY CHECK

**WARNING**

Before starting the work, check that there is nobody or no obstacle in the surrounding and sound a horn for caution. Particularly when using the radio control unit, pay special attention to the machine and the surrounding, and start using the radio control unit only after judging that there is no safety problem around at all.

Check list when starting work

(Conduct a cloth check based on this check list)

1. Check that there is no damage on the safety devices of the transmitter.
Check the switches and the other vital parts for any damage. If any, do not start the work until after that damaged part is properly repaired.
2. Check that the POWER switch of the unit is set at the OFF position.
3. Install the charged batteries in the battery holder at the bottom of the transmitter.
4. Turn the POWER switch key of the unit to switch on the transmitter.
5. The transmitter's red lamp begins to flash.
6. The transmitter's green lamp begins to flash about two seconds after that and at the same time the revolving working lamp (blue) comes on.
With this, the unit is ready for operation.

NOTICE

As long as the TRANSMISSION STOP switch remains depressed, the work equipment cannot be started. Release the switch by depressing it again and start the work equipment.

To check if the radio control unit is properly functioning, follow the procedures explained below.

- 1) Set the engine starting switch in the main control box to the ON position.
- 2) Turn the radio control unit ON/OFF switch in the main control box to the ON side.
- 3) Set the POWER switch in the transmitter to the ON position.
- 4) Pull the TRANSMISSION STOP switch in the transmitter. The revolving working lamp on the machine comes on.
The radio control unit may be operated now.

REPLACEMENT OF BATTERY

**WARNING**

When the charged level in the batteries goes down, the red lamp begins to flash. In that case, take the following actions promptly.

- Move the machine to a safe place, or bring it under safe conditions within 30 seconds, using the radio control unit.
The transmitter is put in the STOP mode in 30 seconds.
Turn the POWER switch to the (0) position and switch off the transmitter.
- Pull out batteries (1) from the battery holder, pushing them a bit forward.
- Insert charged replacement batteries.
- The radio control unit is now ready for use again.

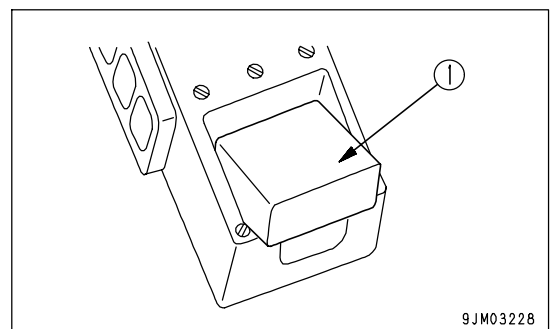

9JM03228

BELT CONVEYOR PROTECTIVE PLATE

CONVEYOR PROTECTIVE BELT

When crushing mainly reinforced concrete debris, a conveyor protection plate is effective at preventing the conveyor belt from breakage.

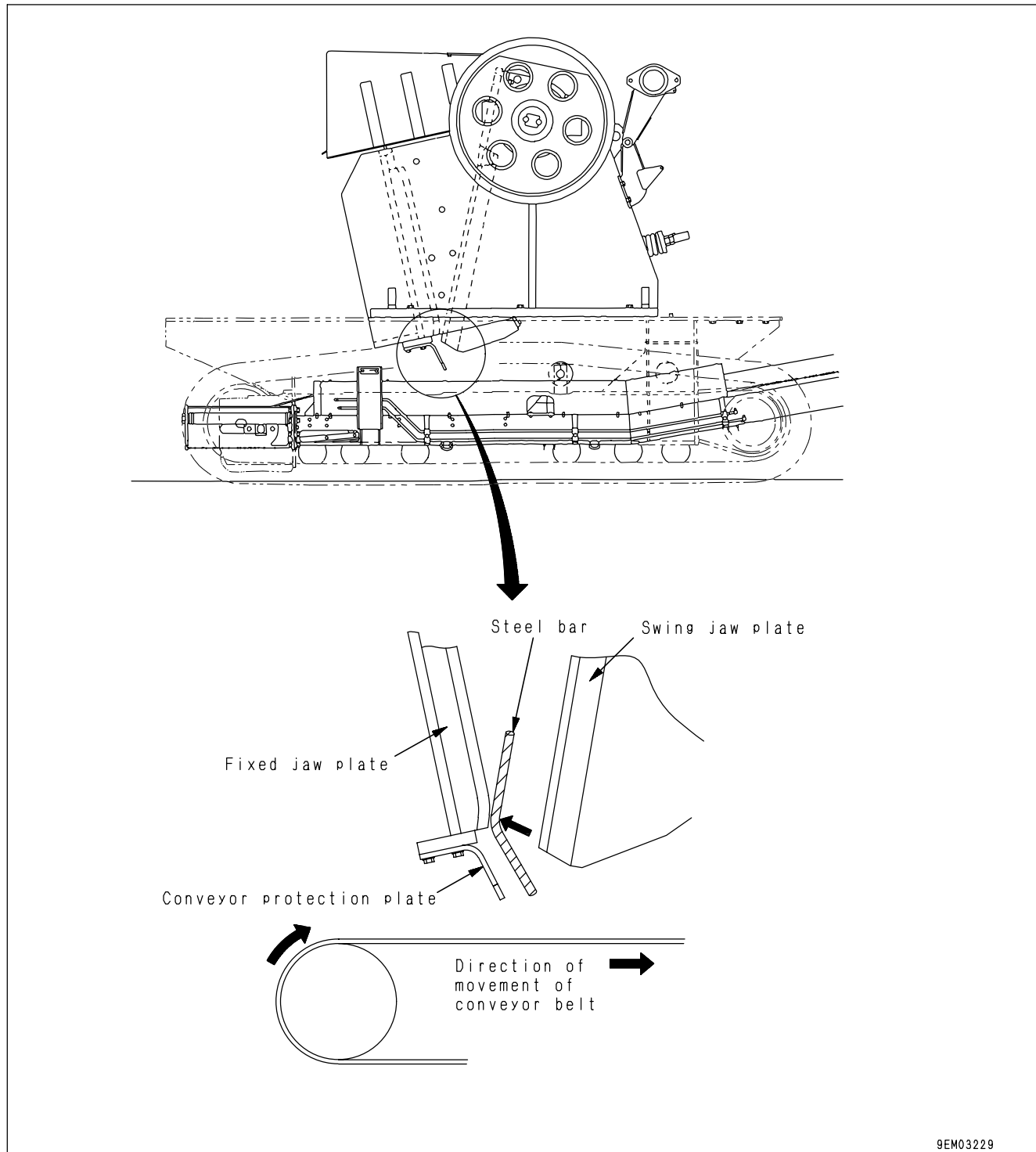

PROCEDURES FOR CONNECTING OPTIONAL ATTACHMENTS

When using the debris discharging conveyor and the magnetic selector individually or in tandem, install hydraulic hoses and electric connectors in the following manner.

LOCATION OF PORTS FOR CONNECTING OPTIONAL ATTACHMENTS

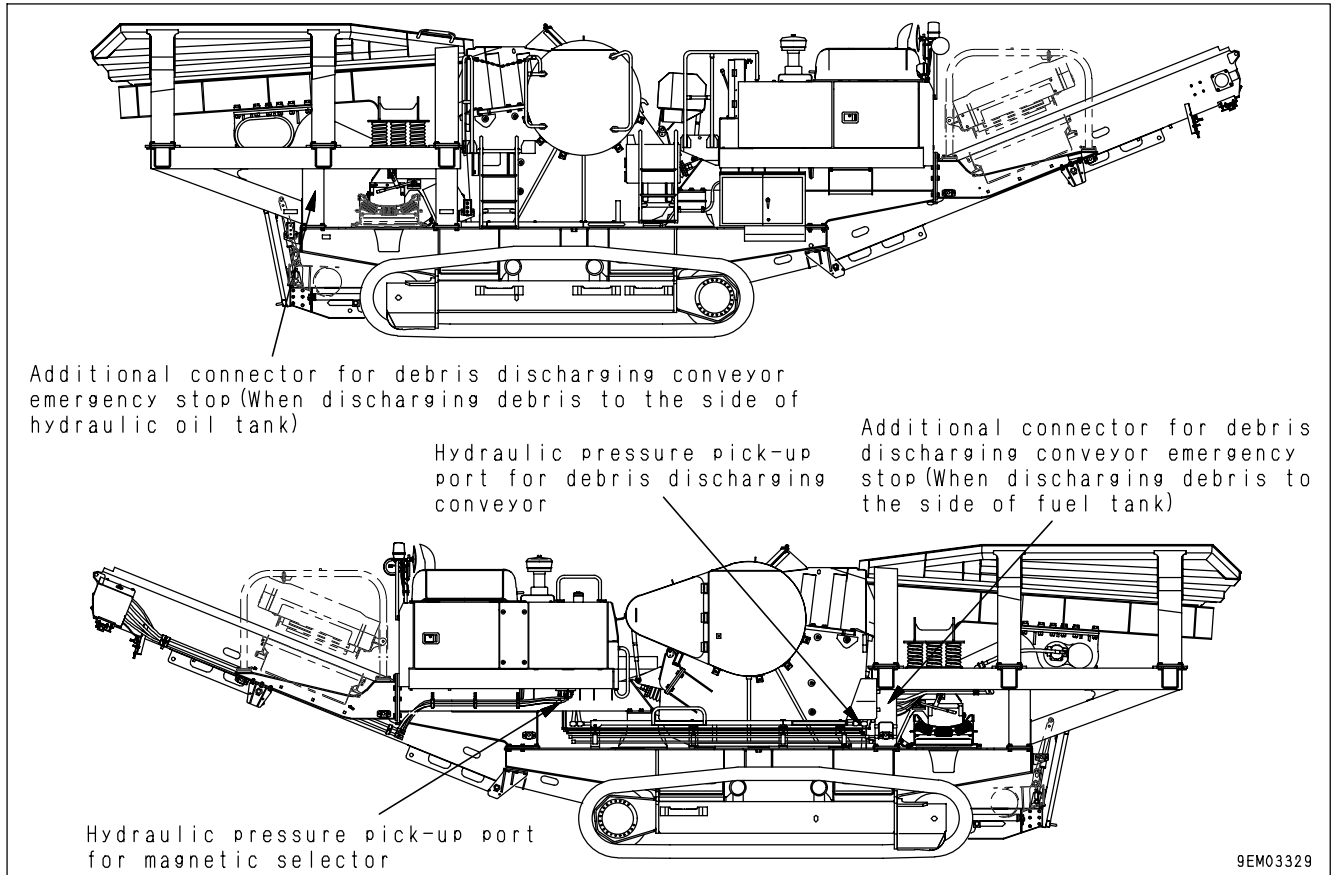

PROCEDURES FOR CONNECTING OPTIONAL ATTACHMENTS

REMARK

The BR550JG model does not adopt a quick coupler (one-touch coupler) for hydraulic intake port. Therefore, remove a blind plug fitted to the machine and connect a hydraulic hose by the conventional way of screwing-in. Both debris discharging conveyor and magnetic selector can discharge crushed debris to either side of the machine.

DEBRIS DISCHARGING BELT CONVEYOR

NOTICE

Connect an additional connector for emergency to either (A) or (B) location, depending on the direction in which the debris discharging conveyor is installed.

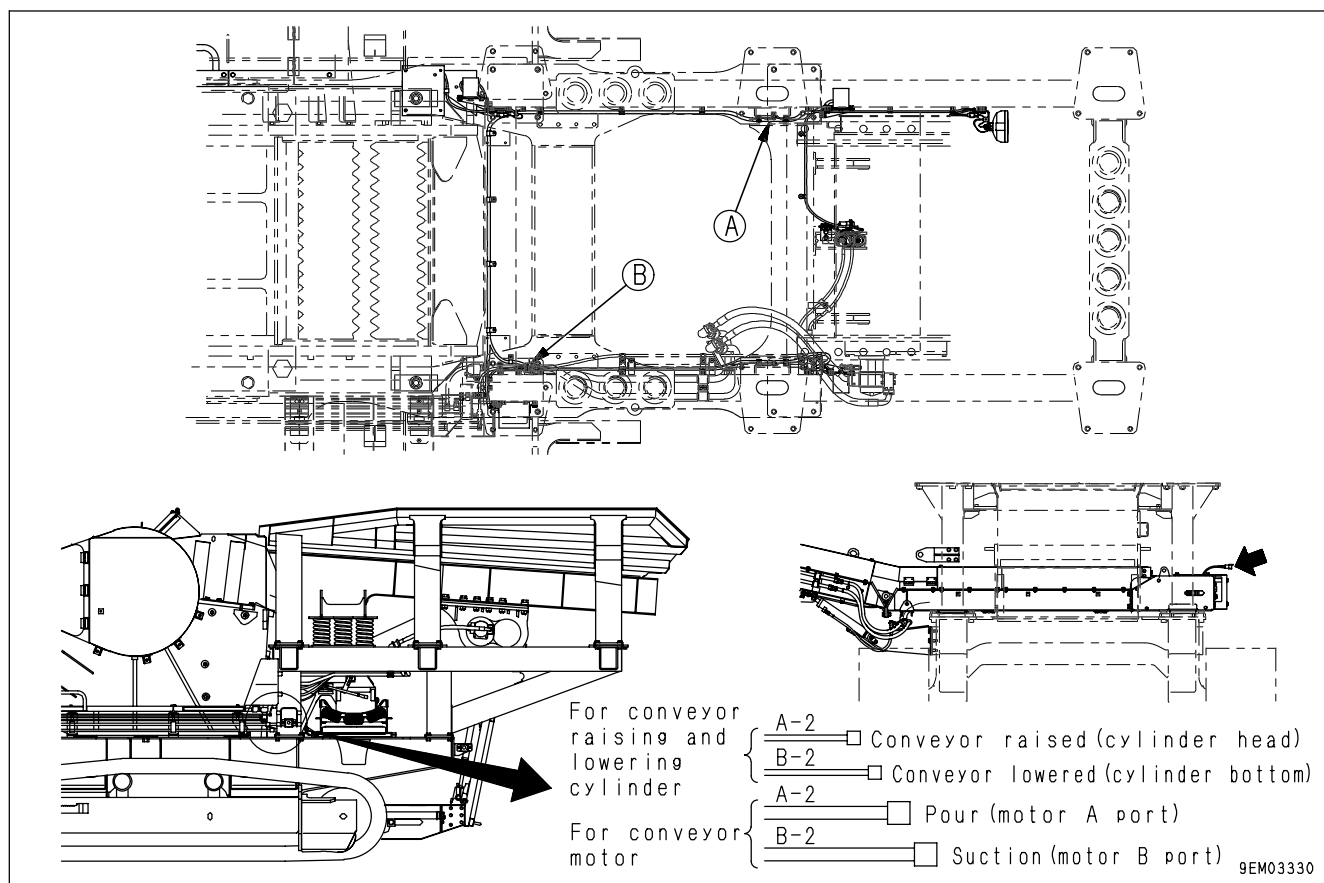

MAGNETIC SELECTOR

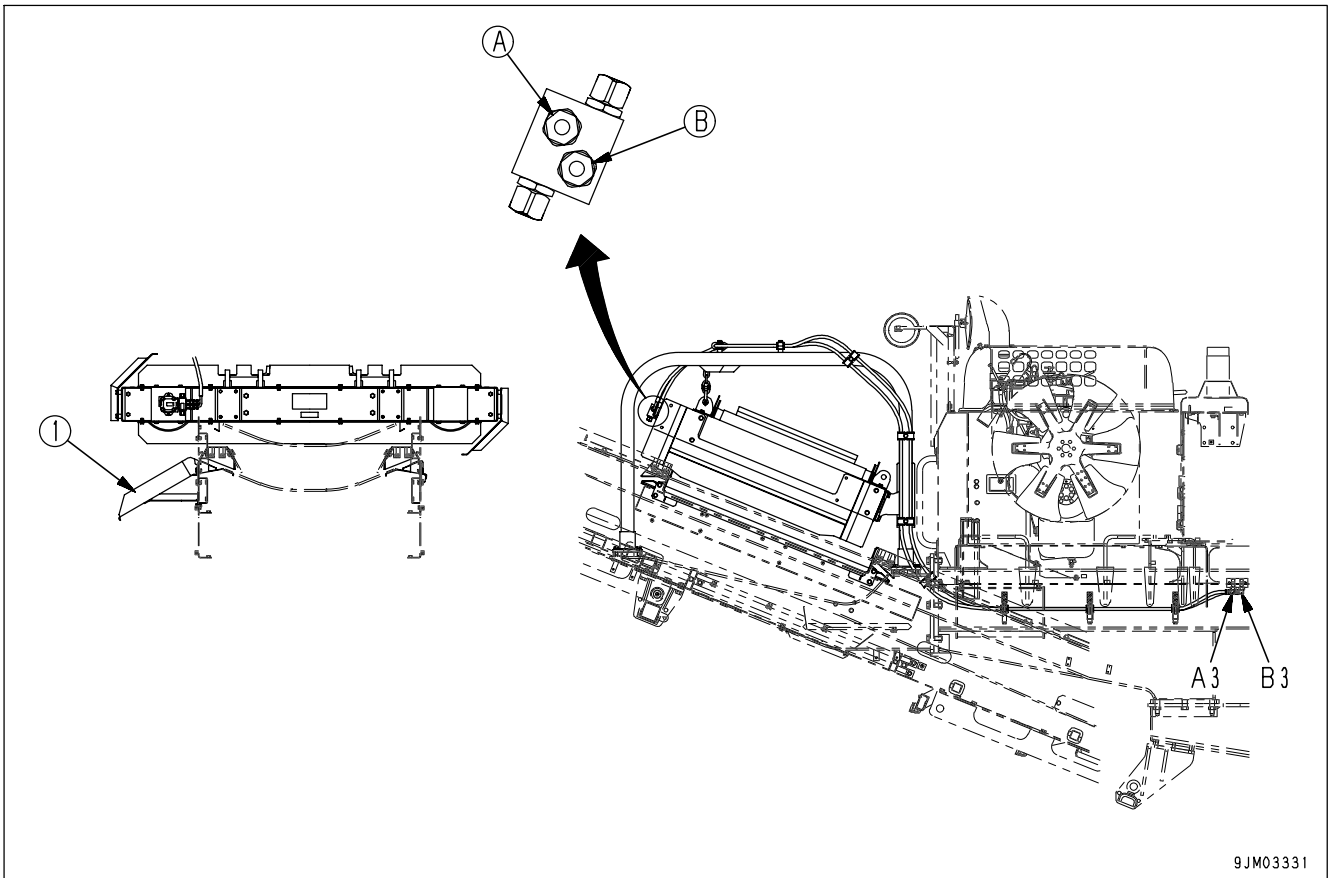

Shredded reinforcing bars may be discharged to the fuel tank side by connecting magnetic selector relay block (B-3) and Av port (A).

Shredded reinforcing bars may be discharged to the side of the hydraulic oil tank by connecting magnetic selector relay block (B-3) and Bv port (B).

REMARK

- Install reinforcing bar discharging guide (1) to the side of the hydraulic oil tank, if discharging to the tank side is desired.
- On the other hand, it is required to install reinforcing bar discharging guide on the opposite side and replace the hydraulic motor piping, if discharging to the fuel tank side is desired.

INDEX

<A>					
ADDITIONAL WORKING LAMP -----	3-	30			
AIR-BLEEDING FROM HYDRAULIC CIRCUIT -----	4-	8			
					
BELT CONVEYOR PROTECTIVE PLATE -----	6-	26			
<C>					
CAP, COVER WITH LOCK -----	3-	27			
CHECK AFTER FINISHING WORK -----	3-	75			
CHECK AFTER STOPPING ENGINE -----	3-	54			
CHECK AND CONFIRMATION OF JAW CRUSHER AFTER WORK -----	3-	75			
CHECK BEFORE STARTING ENGINE -----	3-	33			
COLD WEATHER OPERATION -----	3-	107			
AFTER COLD WEATHER -----	3-	108			
AFTER COMPLETION OF WORK -----	3-	108			
PRECAUTIONS FOR LOW TEMPERATURE -----	3-	107			
CONTROL LEVERS -----	3-	25			
CONTROLLERS -----	3-	31			
CRUSHER ACCESSORY TOOLS -----	4-	18			
<E>					
EFFICIENT USE OF JAW CRUSHER -----	3-	81			
ENGINE SERIAL NO. PLATE AND POSITION -----	1-	8			
EXPLANATION OF COMPONENTS -----	3-	5			
<F>					
FOREWORD -----	1-	2			
FRONT/REAR, LEFT/RIGHT DIRECTIONS OF MACHINE -----	1-	7			
FUSE -----	3-	31			
FUSIBLE LINK -----	3-	30			
<G>					
GENERAL PRECAUTIONS -----	2-	12			
GENERAL PRECAUTIONS -----	6-	2			
PRECAUTIONS RELATED TO SAFETY -----	6-	2			
GENERAL VIEW -----	3-	2			
GENERAL VIEW OF CONTROLS AND GAUGES -----	3-	3			
GENERAL VIEW OF MACHINE -----	3-	2			
GUIDE TO MAINTENANCE -----	4-	2			
<H>					
HANDLING OIL, FUEL, COOLANT, AND PERFORMING OIL CLINIC -----	4-	4			
HYDRAULIC TYPE MAGNETIC SELECTOR -----	6-	3			
CHECK AND INSPECTION -----	6-	4			
FAILURES AND CORRECTIVE ACTIONS -----	6-	5			
LIST OF CHECKPOINT -----	6-	5			
LIST OF WEARING PARTS -----	6-	7			
PRECAUTIONS IN USE -----	6-	3			
PROCEDURES FOR CONNECTION WITH CRUSHER -----	6-	3			
SAFETY PRECAUTIONS -----	6-	3			
SPECIFICATIONS -----	6-	6			
<I>					
INTRODUCTION -----	1-	7			
<J>					
JAW CRUSHER RELATED PARTS -----	4-	10			
<L>					
LIFTING MACHINE -----	3-	106			
LOADING, UNLOADING WORK -----	3-	99			
LOCKING -----	3-	75			
LONG-TERM STORAGE -----	3-	110			
AFTER STORAGE -----	3-	110			
BEFORE STORAGE -----	3-	110			
DURING STORAGE -----	3-	110			
STARTING MACHINE AFTER LONG-TERM STORAGE -----	3-	110			
<M>					
MACHINE MONITOR -----	3-	5			
MACHINE OPERATION -----	3-	55			
MACHINE SERIAL NO. PLATE AND POSITION -----	1-	8			
MAINTENANCE SCHEDULE CHART -----	4-	22			
MAINTENANCE SCHEDULE CHART -----	4-	22			
MUCK DISCHARGE CONVEYOR -----	6-	8			
ASSEMBLING PROCEDURES -----	6-	9			
CHECK AND ADJUSTMENT OF MUCK DISCHARGE CONVEYOR -----	6-	12			
FAILURES AND CORRECTIVE					

ACTIONS -----	6- 14		
GREASING MUCK DISCHARGE CONVEYOR -----	6- 11	<R>	
LIFTING PROCEDURES -----	6- 8	RADIO CONTROL UNIT -----	6- 19
PROCEDURES FOR FOLDING DEBRIS DISCHARGING CONVEYOR ---	6- 10	DIRECTIONS FOR USE -----	6- 19
SPECIFICATIONS -----	6- 18	ON USE OF RADIO CONTROL UNIT ---	6- 22
WEARING PARTS -----	6- 16	OVERVIEW -----	6- 21
		RELATING TO ELECTRIC SYSTEM -----	4- 7
<N>		REVOLVING WARNING LAMP -----	3- 29
NECESSARY INFORMATION -----	1- 8	RUN-IN OPERATION OF JAW CRUSHER -----	3- 76
<O>		<S>	
OPENING-CLOSING TYPE HOPPER -----	3- 67	SAFETY -----	2- 2
OPERATION -----	3- 33	SAFETY CRITICAL PARTS -----	4- 21
OPERATION OF WORK EQUIPMENT -----	3- 61	SAFETY INFORMATION -----	1- 5
OPERATIONS AND CHECKS AFTER STARTING ENGINE -----	3- 52	SAFETY LABELS -----	2- 5
OPTION-RELATED SWITCHES -----	3- 26	POSITIONS OF SAFETY PICTOGRAMS -----	2- 6
OUTLINE OF HYDRAULIC EQUIPMENT --	4- 7	SAFETY LABELS -----	2- 7
OUTLINE OF SERVICE -----	4- 4	SCOPE OF WORKS USING MOBILE CRUSHER -----	3- 86
		SERVICE PROCEDURE -----	4- 24
<P>		CHECK BEFORE STARTING -----	4- 59
PERIODIC REPLACEMENT OF SAFETY CRITICAL PARTS -----	4- 21	EVERY 100 HOURS SERVICE -----	4- 60
POSITION OF SERVICE METER -----	1- 9	EVERY 1000 HOURS SERVICE -----	4- 74
PRECAUTIONS FOR MAINTENANCE -----	2- 31	EVERY 2000 HOURS SERVICE -----	4- 79
PRECAUTIONS FOR OPERATION -----	2- 19	EVERY 250 HOURS SERVICE -----	4- 62
BATTERY -----	2- 28	EVERY 4000 HOURS SERVICE -----	4- 81
CRUSHING OPERATION -----	2- 24	EVERY 500 HOURS SERVICE -----	4- 69
OPERATION -----	2- 21	EVERY 5000 HOURS SERVICE -----	4- 82
STARTING ENGINE -----	2- 19	INITIAL 250 HOUR MAINTENANCE (ONLY AFTER THE FIRST 250 HOURS) -----	4- 24
TOWING -----	2- 30	WHEN REQUIRED -----	4- 25
TRANSPORTATION -----	2- 27	SPECIFICATIONS -----	5- 2
PRECAUTIONS WHEN OPERATING JAW CRUSHER -----	3- 79	STANDARD TIGHTENING TORQUES FOR BOLTS AND NUTS -----	4- 18
PRECAUTIONS WHEN TRAVELING UP OR DOWNHILLS -----	3- 94	STARTING ENGINE -----	3- 49
PRIMARY CONVEYOR RELATED PARTS -----	4- 12	STEERING MACHINE -----	3- 59
PROCEDURE FOR DISASSEMBLY AND FOLDING -----	3- 97	STOPPING ENGINE -----	3- 54
PROCEDURES FOR CONNECTING OPTIONAL ATTACHMENTS -----	6- 27	SWITCHES -----	3- 16
LOCATION OF PORTS FOR CONNECTING OPTIONAL ATTACHMENTS -----	6- 27		
PROCEDURES FOR CONNECTING OPTIONAL ATTACHMENTS -----	6- 28	<T>	
PROHIBITIONS FOR OPERATION -----	3- 92	TABLE OF ENTER SERIAL NO. AND DISTRIBUTOR -----	1- 9
		TOOL BOX -----	3- 32
		TORQUE LIST -----	4- 20
		TRANSPORTATION -----	3- 95
		TRANSPORTATION PROCEDURE -----	3- 95
		TROUBLESHOOTING -----	3-111

INDEX

IF BATTERY IS DISCHARGED -----	3-112	LUBRICANTS ACCORDING TO	
METHOD OF TOWING MACHINE -----	3-111	AMBIENT TEMPERATURE -----	4- 14
OTHER TROUBLE -----	3-115	<W>	
PHENOMENA THAT ARE NOT		WATER SPRINKLER -----	3- 66
FAILURES -----	3-111	WEAR PARTS -----	4- 9
<U>		WEAR PARTS LIST -----	4- 9
USE OF FUEL, COOLANT AND			

BR550JG-1 GALEO MOBILE CRUSHER

Form No. PEN00020-00

©2004 KOMATSU

All Rights Reserved

Printed in Japan 11-04
