

YANMAR

OPERATOR'S MANUAL

ROTARY TILLER

RH170

RH190

 Original instructions

TO THE OWNER

Be sure to read this operator's manual before using.

This operator's manual describes how to use this rotary correctly and safely and precautions for using it. Read this manual carefully before using the rotary. Keep this manual close to your tractor, after you have read through it.

- Do not use this rotary until you understand the contents of this operator's manual.
- When you lend or transfer this rotary, attach this operator's manual to the rotary.
- When lost or damaged the operator's manual or safety labels, order promptly it from the store you purchased the rotary.
- The operator's manual describes safety instructions for safety operations. Be sure to read before use.
- The rotary may change using parts for improvement. A part of illustrations, pictures and contents etc. may be different from the actual rotary.
- Right-hand and Left-hand sides of the rotary are determined by facing in the direction of the tractor forward travel.

Symbols used



DANGER

"DANGER" indicates an imminently hazardous situation which, if not avoided, will result in death or serious injury.



WARNING

"WARNING" indicates a potentially hazardous situation which, if not avoided, could result in death or serious injury.



CAUTION

"CAUTION" indicates a potentially hazardous situation which, if not avoided, could result in minor or moderate injury.



IMPORTANT

This [IMPORTANT] symbol indicates important proper operation or service messages in this manual. When you see this symbol, carefully read the messages that follow.

[NOTE]

"NOTE" describe precautions to take while working.

The using purpose of the rotary

Use this rotary for tilling and/or cultivating farm land by attaching to an agricultural tractor.

Never work for a purpose other than agricultural works and never modify by yourself. Keep in mind that it would not be covered by the warranty in case that the rotary is modified without the approval of YANMAR.

Applicable tractor

Rotary Model	Tractor Model
RH170	EF393T
RH190	EF494T

TABLE OF CONTENTS

TO THE OWNER	1
[1] Safety instructions	4
1-1. General cautions	4
1-2. When checking before and after work	6
1-3. When attaching/detaching the rotary	7
1-4. Cautions for work	7
1-5. Storing after work	8
1-6. Location of safety labels	10
[2] After-sale service	11
Warranty documents	11
After-sale service	11
[3] Outline of rotary	12
[4] Attaching and detaching the rotary	13
4-1. Installing the lower link and the lift link	13
4-2. Installing the top link	15
4-3. Attaching/detaching the rotary	16
4-4. Adjusting the rotary	18
4-5. Installing tilling blade	19
[5] Check before work	21
5-1. Check procedure	21
5-2. Check points	21
[6] Adjusting the rotary to work	22
6-1. PTO shift	22
6-2. Adjusting rear cover	22
[7] Periodical check and maintenance	24
7-1. Periodic check table	24
7-2. Replacing gearbox oil	25
7-3. Replacing chain case oil	25
7-4. Replacing bearing case R oil	26
7-5. Grease and oil	26
7-6. Replacing tilling blade	27
[8] Others	28
Specifications	28

[1] Safety Instructions

- Be sure to follow the instructions described here for safety operations.
 - If you do not follow the safety instructions, it may cause injury, death, and may cause a breakage on the rotary.
- * Some instructions may not apply the rotary.

1-1. General cautions

WARNING

■ Never operate in such cases.

- Not good physical condition due to overwork, ill or medication etc.
- Drunk.
- Pregnant.
- Under aged to take driver's license



■ Suitable clothing for work.

- Don't wear loose clothing or muffler to avoid from being caught in a control lever or rotating part.
- Wear non-slip shoes and helmet.



■ When lending others the machine.

Explain how to operate and tell to read the operator's manual well before use.



■ When equipping an implement to the rotary, read the operator's manual of the implement.

When you equip an implement to the rotary, be sure to read the operator's manual of the implement well in advance.

CAUTIONS

■ Never modify by yourself.

Use always genuine spare parts and never modify by yourself.



■ Perform check and service.

Be sure to check and service before and after using the rotary.



■ Perform periodical check and service.

Perform periodical check and service at least annually or every 1000 hours operation when the time comes earlier.

■ Follow traffic regulation when driving on a road.

Observe traffic regulation when driving on a road.



1-2. When checking before and after work

WARNING

- Prevent the rotary from falling down when checking and servicing.

At the time of check and service, close hydraulic slow/stop valve to prevent the rotary from falling down. In addition, put stands under skids or tilling blade shaft for safety.

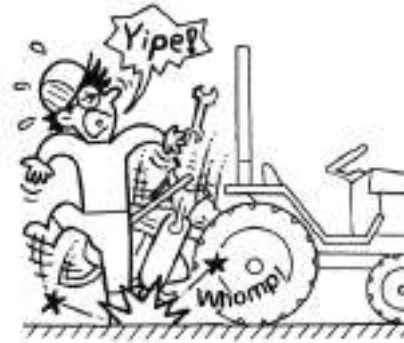

- Perform check and service on a flat and stabilized place.

Perform check and service on a flat and stabilized place to prevent the machine from moving or falling down.

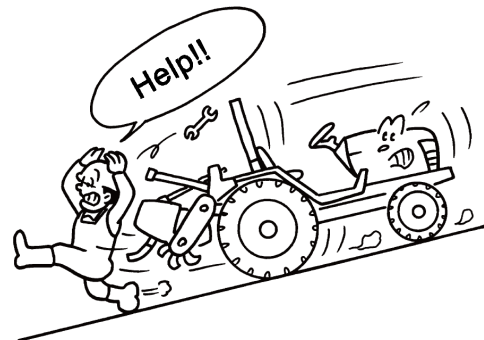

- Reinstall removed covers.

Be sure reinstalling covers that were removed for servicing.



CAUTION

- Be sure a rotation part stops.

Move PTO gear shift lever to the neutral position and stop the engine. Be sure the rotating parts stop completely when performing check and service.



1-3. When attaching/detaching the rotary

WARNING

- Perform attaching/detaching the rotary to/from the tractor on a flat place.

Perform attaching/detaching the rotary on a flat and stabilized place. Light up at night time.

- Never allow bringing a person close up to the tractor and rotary.

When driving the tractor to detach/attach the rotary, keep people away from the tractor and rotary.

- Check 3-P hitch link connection before lifting the rotary.

After attaching the rotary to the tractor, check the connection of top link, lower links and lift links before lifting the rotary by the position control lever.

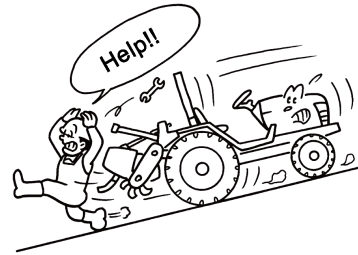

1-4. Cautions for work

WARNING

- Pay attention to people around the tractor when steering or reversing the tractor with the rotary.

Be careful of surrounding people when reversing or steering the tractor with the rotary.

- Be sure to stop the engine when removing twined objects from tilling blade shaft.

Never fail to stop the engine whenever removing the twined objects such straw, grass and weeds from the tilling blade shaft.

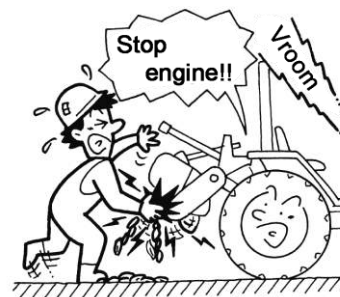

■ **Never put hand or foot under the rotary.**

Never get under the rotary. Never put hand or foot under the rotary.



■ **Keep a child away from the tractor.**

Never bring a child close to the tractor.



■ **Beware of dashing of the tractor in rotary work.**

During rotary tilling work, the tractor may dash suddenly in a field of hard soil condition, and/or there are hard object such stones, wood or stump, or much straws etc. in a field. The rotating blades push the tractor when blades hit hard objects.

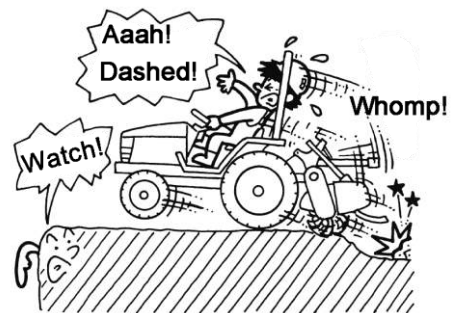

■ **Use the rotary for only tilling work.**

Never work other than rotary tilling work.



1-5. Storing after work

WARNING

■ **Prevent the rotary from falling down when checking and servicing.**

At the time of check and service, close hydraulic slow/stop valve to prevent the rotary from falling down. In addition, put stands under skids or tilling blade shaft for safety.



■ **Perform check and service on a flat and stabilized place.**

Perform check and service on a flat and stabilized place to prevent the machine from moving or falling down.

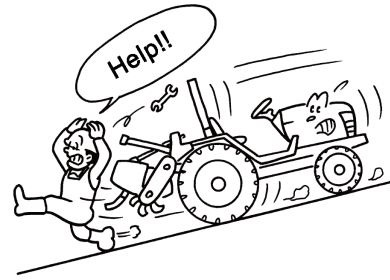

■ **Be sure to stop the engine for check and service.**

Be sure to stop the engine when you carry out check, service and repair, or cleaning.

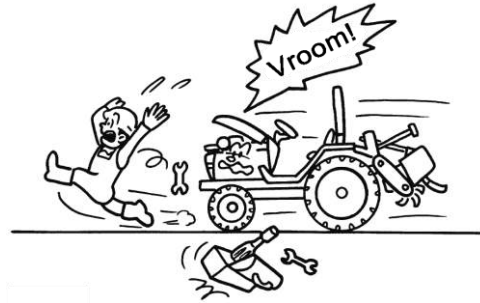

■ **Reinstall removed covers.**

Be sure reinstalling covers that were removed for servicing.



CAUTION

■ **Put the rotary on a flat place when storing.**

When you store the rotary, lower the skid, put on a flat place and put a support to prevent from falling down.

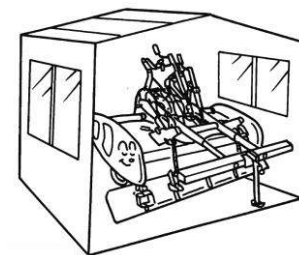

■ **Be sure a rotation part stops.**

Move PTO gear shift lever to the neutral position and stop the engine. Be sure the rotating parts stop completely when performing check and service.



1-6. Location of safety labels

Keep the safety instructions labels clean and clearly visible for your safety. If any of them are damaged or missing, replace them with new ones.

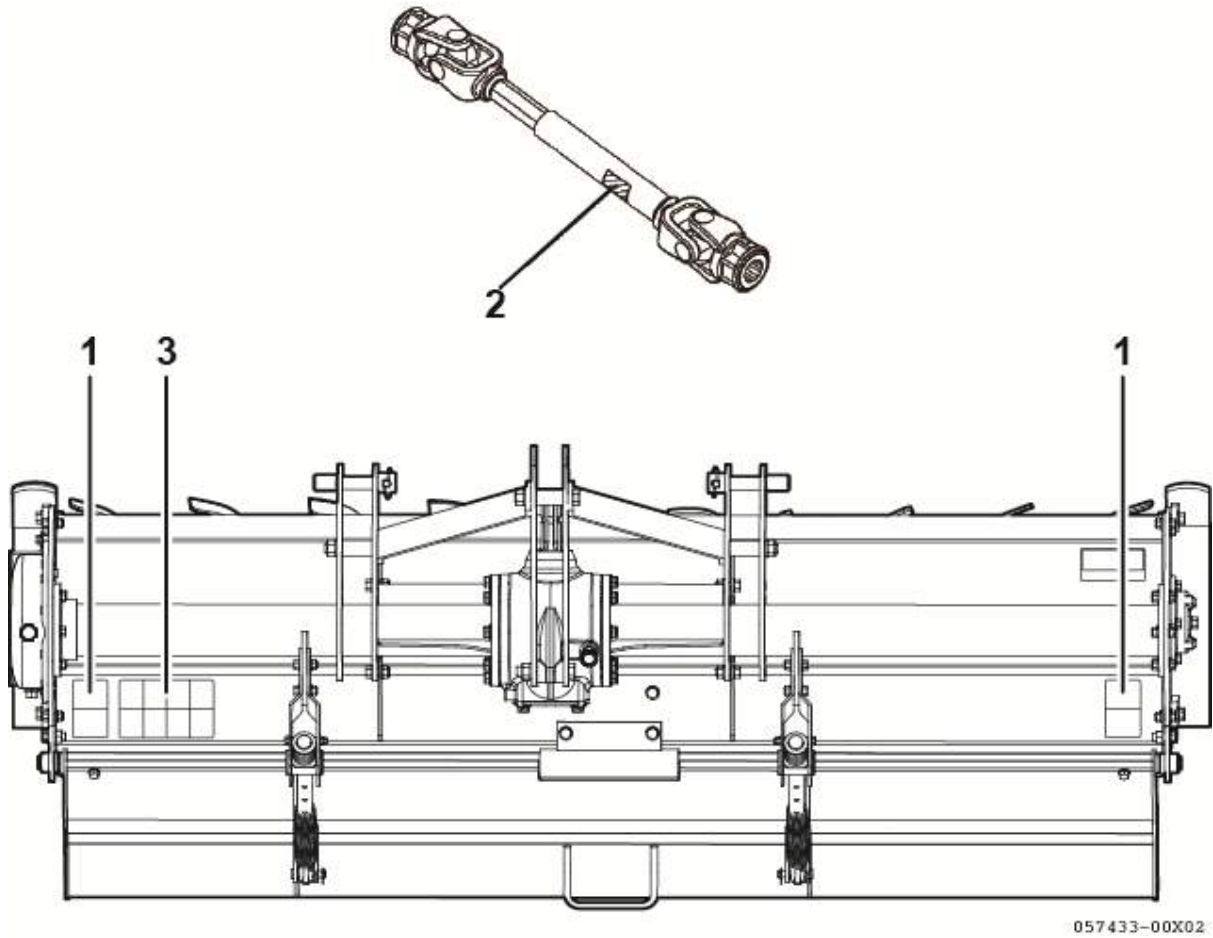

057433-00X02

1. 1B1657-10630



2. 1A6150-93151



3. 1B1657-10660

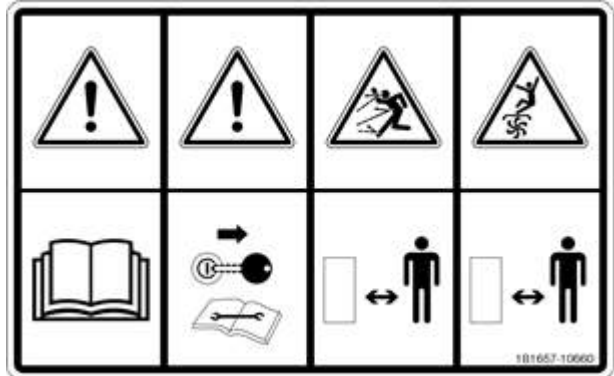

[2] After-sale service

Warranty documents

The warranty document is needed when a machine defect is covered and collected under warranty conditions. Read it carefully and keep properly.

After-sale service

When your rotary is not working normally, you can of course consult with your service representative. Whenever you ask service to your service representative, following information are very helpful to identify your rotary.

<<Items to be required>>

- Model name and serial number

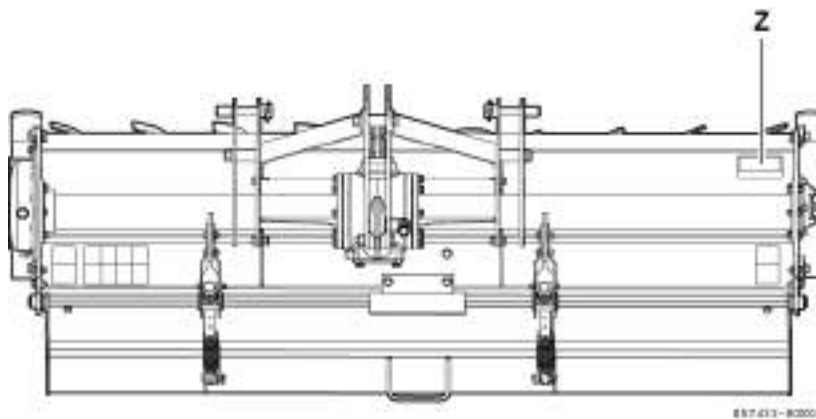

[Z] Model name and serial number

RH170



RH190

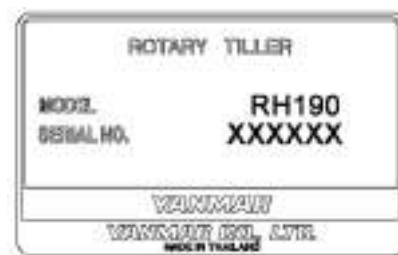

- Using situation, kind of work
 - e.g. paddy field, vegetable field, etc.
- Operating hours
 - Check the operating hours with the tractor hour meter.
- Situation or working type when the fault occurs as in detail as possible.

<< Availability of spare parts >>

Maintenance parts or spare parts are available for 10 years after the production of this tractor series has been discontinued. However, special parts will be subject to consultation. Yanmar may be able to supply a particular part after the normal supplying period.

[3] Outline of rotary

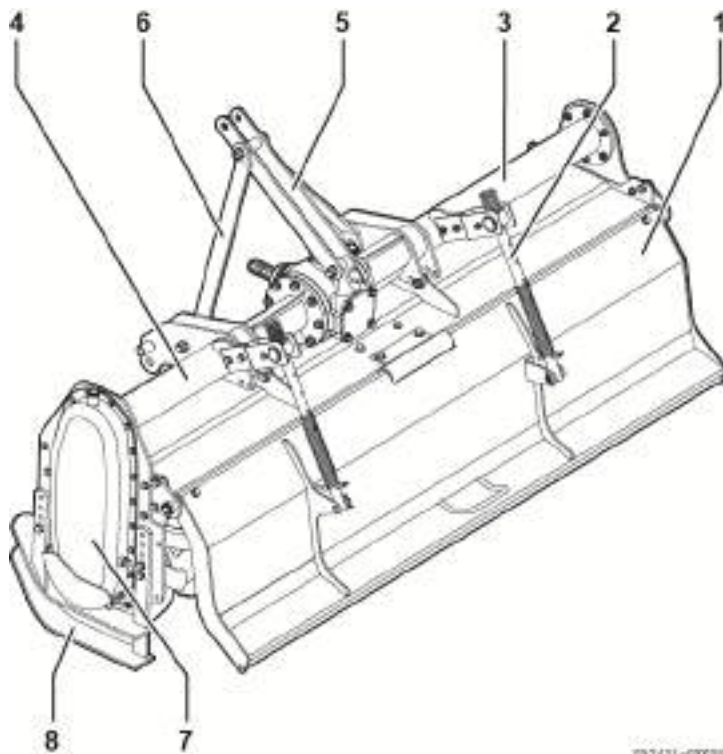

057431-00000

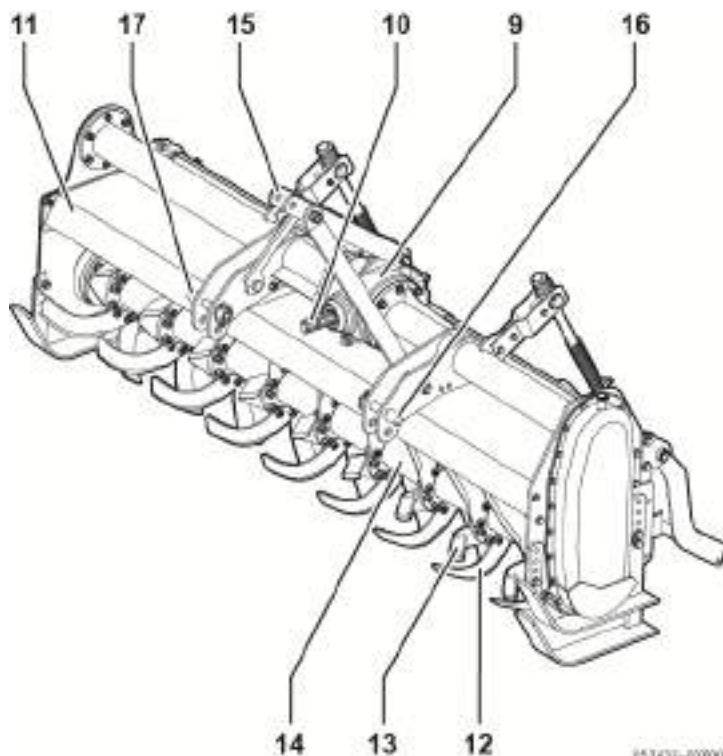

057432-00000

- | | |
|---------------------|------------------------------|
| 1. Rear cover | 9. Gear box |
| 2. Hanger rod | 10. Rotary pinion shaft |
| 3. Main frame R | 11. Rotary cover |
| 4. Main frame L | 12. Tilling blade R |
| 5. Mast | 13. Tilling blade L |
| 6. Upper arm stay | 14. Rotary shaft |
| 7. Chain case cover | 15. Top link hitch point |
| 8. Skid | 16. Lower link L hitch point |
| | 17. Lower link R hitch point |

[4] Attaching and detaching the rotary

WARNING

- Perform attaching and detaching the rotary on a flat place. Take special attention if attaching or detaching the rotary at night with well lighting facility.
- When reversing the tractor for attaching the rotary, keep people stay away from the tractor and rotary.
- In adjusting a rotary, Apply the parking brake of the tractor, stop the engine and move all speed shift levers to neutral position whenever adjusting the rotary.
- Never get under the rotary. Never put hand or foot under the rotary. It may cause an injury.
- Never raise the rotary with installing only one side lift link.
- Be sure to stop the engine whenever removing or installing the PTO drive shaft. It may cause an injury.

CAUTIONS

- When you store the rotary, lower the skid, put on a flat place and put a support to prevent from falling down.
- Install PTO shaft cover on the tractor if PTO drive is not used.
- When an additional implement is equipped, install balance weight as required to maintain stability.

4-1. Installing the lower link and the lift link

1. Install the lower link and the lift link.

(A) Top link: adjust leaning of the rotary backward or forward.

(BL) Lift link, Left

(BR) Lift link, Right: adjust tilting of the rotary right and left.

(C) Check chain: adjust swing of the rotary right and left.

(D) Lower link

The picture shows EF393T.

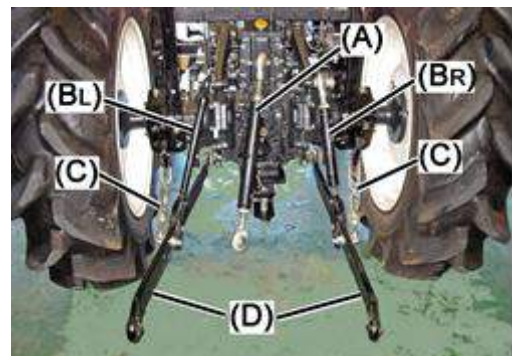

(A) Top link

(BL) Lift link, Left

(BR) Lift link, Right

(C) Check chain

(D) Lower link



IMPORTANT

Set correctly the lower link hole position and a lift link hole position. If it was not set correctly, following faults arise.

- When moving the position control lever, the rotary may touch the tractor, or may damage the tractor and/or the rotary.
- The drive shaft may cause noise or come off.

Setting the **lower ling** and the lift link

EF393T+RH170

Tractor model	EF393T
Lower link hole position	(a)
Lift link hole position	[1]
Check chain hole position	(b)

EF393T

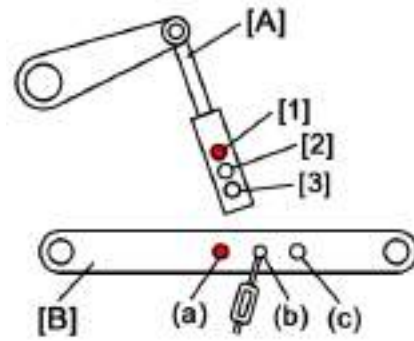

[A] Lift link [B] Lower link

EF494T+RH190

Tractor model	EF494T
Lower link hole position	(b)
Lift link hole position	[1]
Check chain hole position	(d)

EF494T

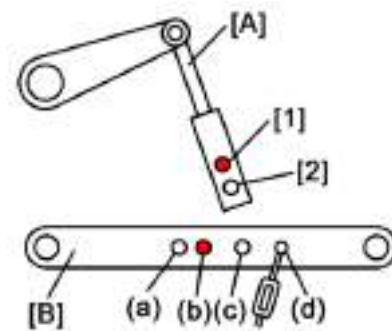

[A] Lift link [B] Lower link

2. Adjust the length of the right lift link (BR) by turning the turnbuckle and make lower ling links (D) being the almost same height.

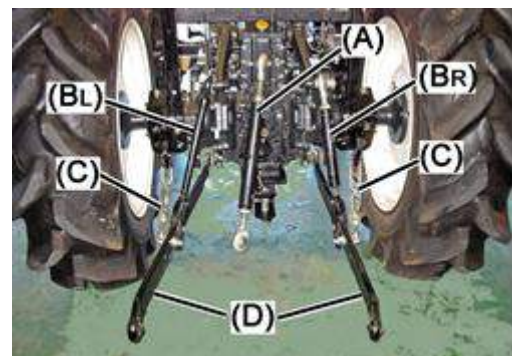

4-2. Installing the top link

Install the top link to the top link hinge.



IMPORTANT

- When vibration occurs by wear of the pin and the hole, replace wear parts with new ones promptly.

Installing the top link

EF393T+RH170

Tractor model	EF393T
Top link length [L]	590 mm
Top link hinge hole position	[2]

EF393T

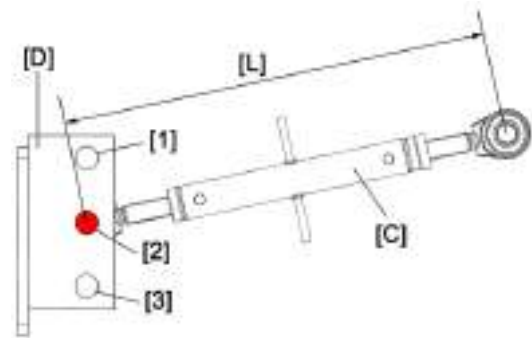

[C] Top link [D] top link hinge

EF494T+RH190

Tractor model	EF494T
Top link length [L]	520 mm
Top link hinge hole position	[2]

EF493T

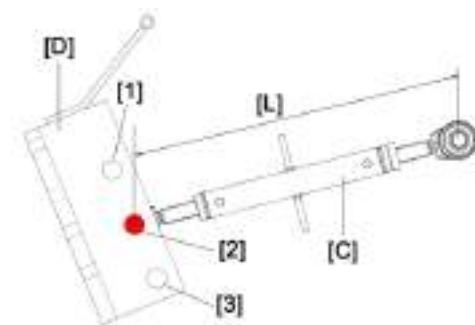

[C] Top link [D] top link hinge

4-3. Attaching/detaching the rotary

WARNING

- Never raise the rotary with installing only one side lift link.
- Be sure to stop the engine whenever removing or installing the PTO drive shaft. It may cause an injury.

4-3-1. Attaching the rotary

1. Attaching order of the rotary to the tractor.

- 1) Attach the left lower link [A] to the rotary.
- 2) Attach the right lower link [B] to the rotary.
- 3) Attach the top link [C] to the rotary.
- 4) Connect the drive shaft [G].

- [A] Lower link (left)
- [B] Lower link (right)
- [C] Top link
- [D] Lift link (left)
- [E] Lift link (right)
- [F] Check chain
- [G] Drive shaft

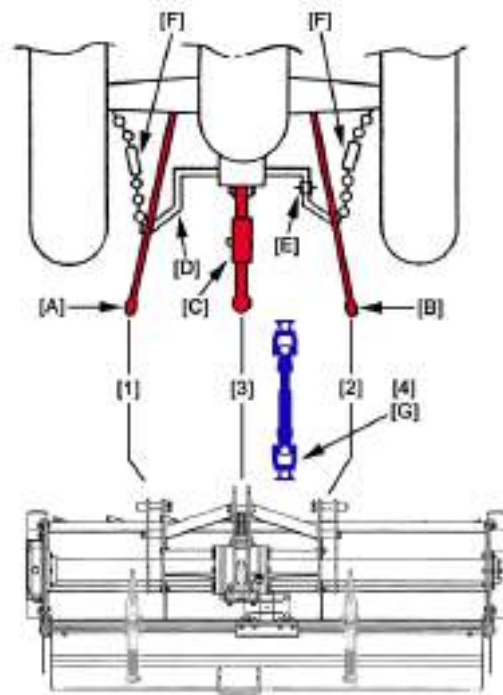

2. Connecting position of top link and lower link to the rotary

- [1], [2] Lower link connecting position
- [3] Top link connecting position

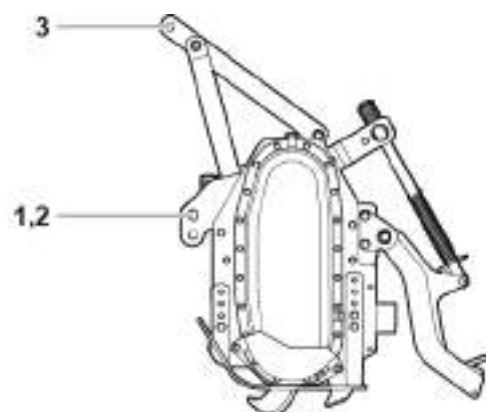

657415-00000

3. Connecting the drive shaft [G].

Push the lock pin [b] and put the drive shaft to the PTO shaft and the rotary pinion shaft.

- [a] PTO shaft/Rotary pinion shaft
- [b] Lock pin
- [G] Drive shaft





IMPORTANT

- Check the lock pin is placed in the groove of the PTO shaft and the rotary pinion shaft.
When the pin is placed in the groove, the pin will return back.

4-3-2. Detaching the rotary



WARNING

- Be sure to stop the engine whenever removing or installing the PTO drive shaft[a]. It may cause an injury.

1. Put the tractor on a flat and hard place.
2. Set right and left skids [b] to the lowest position.
3. Lower the rotary till skids are on the ground.
4. Stop the engine.

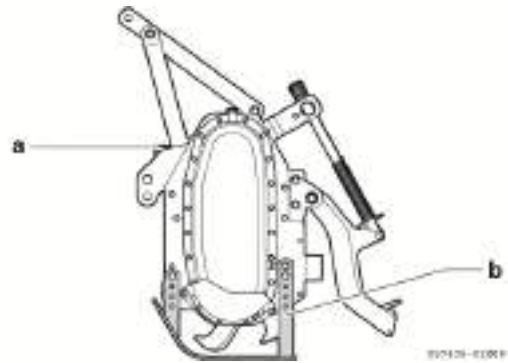

[b] Skid (right and left)

5. Remove the drive shaft.
Push the lock pin and pull the drive shaft. Remove the rotary side first.
6. Pull out the pin of a top link and remove the top link.
7. Remove the right side lower link.
8. Remove the left side lower link.

4-4. Adjusting the rotary

Adjust the rotary after attaching to the tractor.

1. Be sure that the PTO shift lever and the main gear shift lever is at the "N" (neutral) position. Be sure the parking brake is applied.

Start the engine.

2. Raise the rotary with the position control lever at a height of about 10 cm and stop the engine.
3. Make the rotary level (A) with the tractor by adjusting the right lift link [a].

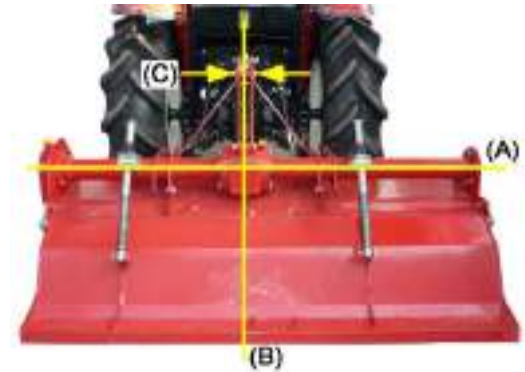

4. Align the centerline of the rotary mast with the centerline of the tractor (B) by adjusting right and left check chains [b].

The free play (C) of right and left movement of the rotary is about 10 mm at the top link hitch pin or lower link hitch pin parts.

Be sure to insert the snap pin to the check chain after adjustment.

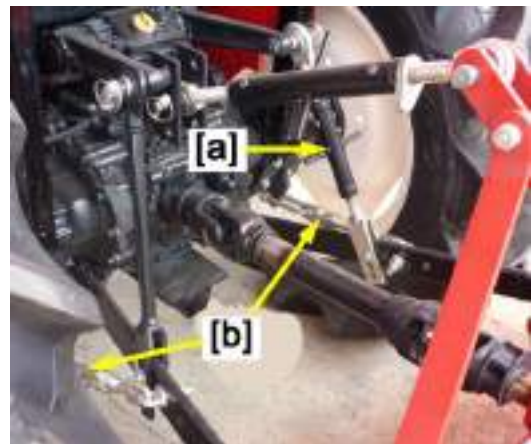

STOP IMPORTANT

- Do not tighten check chains too much strongly. It may cause a breakage.

5. Start the engine and engage the PTO shift lever to the low speed. Raise and lower the rotary slowly with the position control lever and check a noise or vibration on the drive shaft or the rotary.

If noise and/or vibration occur, stop the engine and check hitching conditions of the rotary.

6. Adjust the height of skids for work.

4-5. Installing tilling blade

⚠ WARNING

- When installing or replacing tilling blades, put the tractor on a level and hard surface place, apply the parking brake and put chocks. If not, it may cause an injury accident.
- When installing or replacing tilling blades, be sure close hydraulic stop valve fully to prevent from the rotary falling down. In addition to the hydraulic stop valve, put a support under the tilling blade shaft or skids for sure. If not, the rotary may fall down and may cause an injury.

Tilling blade installing (figure from the back side view)

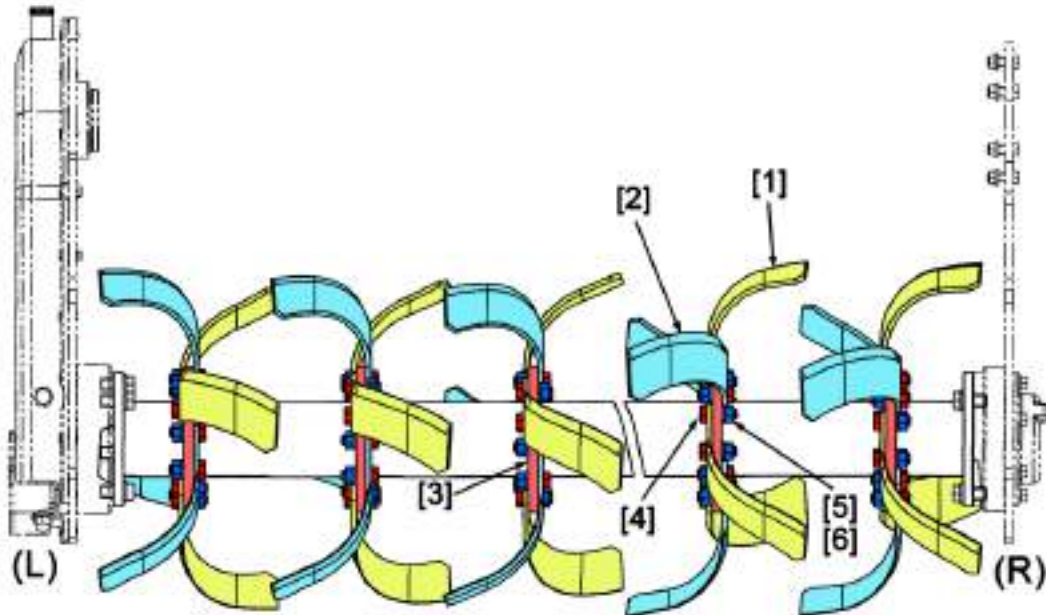

[1] Right tilling blade:

RH170/24 blades, RH190/27 blades

[2] Left tilling blade:

RH170/24 blades, RH190/27 blades

[3] Flange

[4] Bolt M12x35, fine thread

[5] Nut M12, fine thread

[6] Spring washer M12

(L) Rotary left side

(R) Rotary right side

Blade and bolt fixing (figure from the back side view)

[1] Right tilling blade

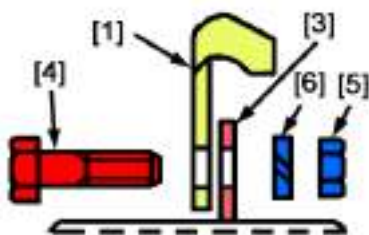

[2] Left tilling blade

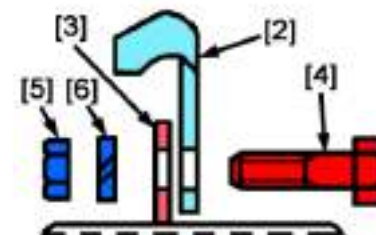

[3] Flange [4] bolt [5] Nut [6] Washer Bolt tightening torque: **98-128 N-m (10-13 kg-m)**

Tilling blade installing direction

The right figure is the view from the left side of the rotary. The small hole on the flange indicates the starting point of installing right tilling blade as the figure shows. Then, rotate the blade shaft in the direction [a] that the right figure shows, and install left tilling blade on the opposite side of right blade installing.

- [a] The rotating direction of tilling blade shaft
- [b] The moving direction of the rotary
- [1] Right tilling blade
- [2] Left tilling blade
- [3] Flange
- [4] Bolt
- [5], [6] nut, washer
- [7] Small hole

The figure from the left side view

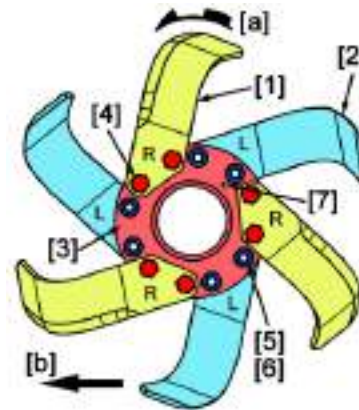

- [a] Rotating direction of tilling blade shaft (from the rotary left side view)
- [b] Moving direction of rotary (from the rotary lift side view)

Small hole is arranged as the under figure shows. The small hole indicates the starting point installing right tilling blade on the left side of the flange as the figure shows. Rotate the blade shaft in the direction of the arrow [a] and install left tilling blade on the right side of the flange. Then, install blade by alternating right and left blades. (The under figure shows RH170)

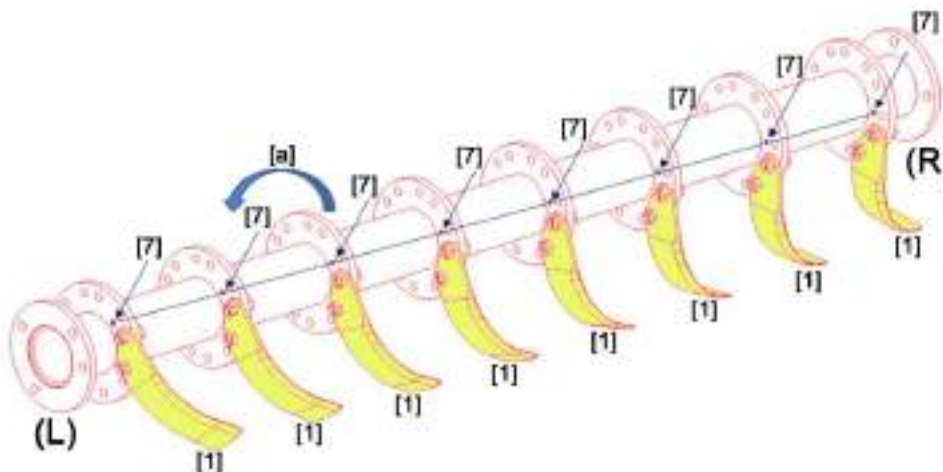

- [a] Rotating direction of tilling blade shaft
- [1] Right tilling blade
- [7] Small blade
- (L) Left side of the rotary
- (R) Right side of the rotary

[5] Check before Work

Check the rotary before work for safety and trouble less work.

Correct a trouble if any.

Check the rotary after work too.

1. Put the tractor on a flat level place and apply the parking brake.
2. Move the reverser lever, the main gear shift lever, range shift lever and PTO shift lever to the "N" (neutral) position.

5-1. Check procedure

1. Start the engine and set the engine speed of about 1500 rpm.
2. Move the position control lever to raise the rotary at the height of about 50 mm from the ground surface.
3. Check that a rotary is level with the ground.
4. Move the position control lever to raise the rotary at the maximum height. Check that the rotary is level with the tractor.

WARNING

- Be sure reinstalling covers that were removed for servicing. If not, it may cause an injury accident.

CAUTION

- Move PTO gear shift lever to the neutral position and stop the engine. Be sure the rotating parts stop completely when performing check and service.

5-2. Check points

- Conditions of the drive shaft lock pin on the PTO shaft and the rotary pinion shaft.
- Snap pin fastening conditions.
- Tightening of tilling blade fixing bolts.
- Oil level of the rotary gear box.
- Oil level of the chain case.



IMPORTANT

- Check oil level with rotary down on the flat place.

[6] Adjusting the rotary to work

WARNING

- Whenever adjusting, be sure stop the engine, put all levers to neutral and see all rotating parts stop. If not, it may cause an injury accident.
- Beware of dashing of the tractor in rotary work.
During rotary tilling work, the tractor may dash suddenly in a field of hard soil condition, and/or there are hard object such stones, wood or stump, or much straws etc. in a field. The rotating blades push the tractor when blades hit hard objects.

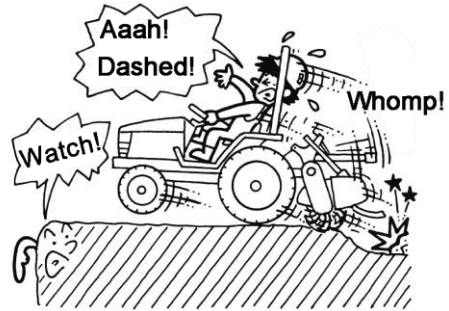

6-1. PTO shift

Choose adequate PTO gear speed from the following table according to work and field conditions.

	RH170/EF393T		RH190/EF494T	
PTO shift	1	2	1	2
PTO speed (rpm)	584	836	568	769
Blade shaft speed (rpm)	256	367	249	337
Engine speed (rpm)	2800		2800	

6-2. Adjusting the rear cover

Adjust the rear cover height (opening) to work.

1. Lowering the rear cover [C].

Insert the snap pin [A] to the lowest hole on the hanger rod [B].

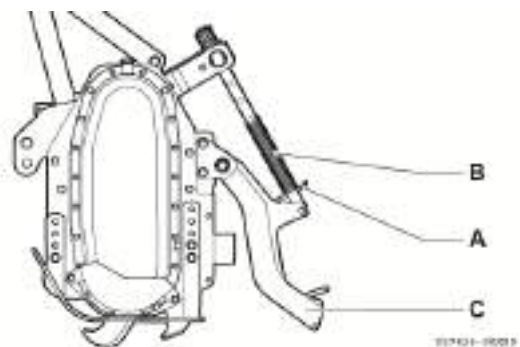

2. Raise the rear cover. (open)

Pull out the snap pin [A], lift the rear cover and insert the snap pin to the desired hole for work. Height is a three-stage of [1], [2], and [3]. The right figure shows the stage [3]. (Highest)

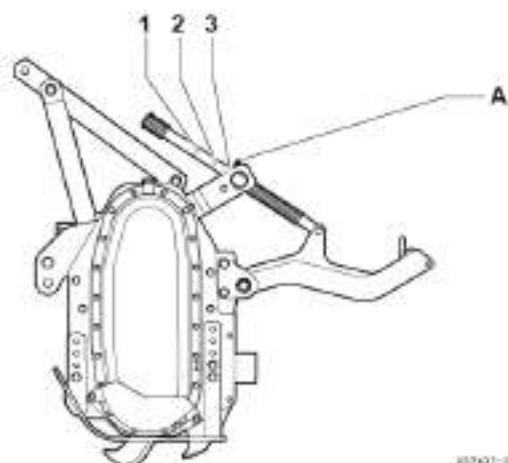

33767-0003

[7] Periodical check and maintenance

7-1. Periodic check table

A: Grease C: Check R: Replace

Item		Time (every hours)							Remarks	
		After work	50	100	200	300	400	500		600
1	Gear box		R			R			R	Replace every 300 hours.
2	Chain case		R			R			R	Replace every 300 hours.
3	Bearing case R		R			R			R	Replace every 300 hours.
4	Grease	A								
5	Gear box oil seal					C			C	Check every 300 hours.
6	Tilling blade shaft oil seal, left					C			C	Check every 300 hours.
7	Tilling blade shaft oil seal, right					C			C	Check every 300 hours.
8	Tilling blade shaft bearing, left								R	Replace every 600 hours.
9	Tilling blade shaft bearing, right								R	Replace every 600 hours.
10	Driven shaft bearing, left								R	Replace every 600 hours.
11	Chain								C	Check every 600 hours.
12	Rear cover hinge pin	A				C			C	Check every 300 hours.
13	Rear cover hinge pin collar					C			C	Check every 300 hours.

Lubrication	Oil type	Capacity	Remarks
Gearbox	Gear oil SAE #90	1.7 Lit.	Filling port
Chain case	Gear oil SAE #90	1.1 Lit.	Filling port
Bearing case R	Gear oil SAE #90	0.1 Lit.	Filling port
Grease	Multipurpose type	Suitable amount	Grease nipple / application

7-2. Replacing gearbox oil

Check oil level as the rotary is lowered on a flat and level place.

<Oil level check>

Check the oil level with the dipstick [1]. Remove the dipstick [1] and wipe off oil. Insert the dipstick without tightening and pull it out. See the oil on the dipstick between upper limit (a) and lower limit (b). If no oil, add. If more than the upper limit, drain.

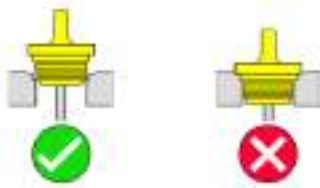

[1] Dipstick [A] gearbox

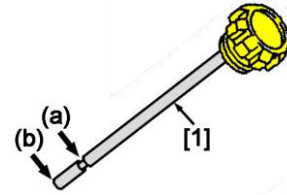

[1] Dipstick (a) Upper limit (b) Lower limit

<Oil replacing>

Remove the drain plug [2] to drain the oil. Remove the dipstick and pour new oil of specified amount.

Oil type: Gear oil SAE #90

Amount: 1.7 Liter

Replace: Every 300 hours.



[2] Drain plug

7-3. Replacing chain case oil

<Oil level check>

Remove the oil level plug and check oil amount. If the oil amount is adequate, oil will come out a little. If more than the specified amount, much oil comes out. If oil is less than the specified amount, no oil comes out.

<Oil replacing>

Remove the drain plug [2] to drain oil. Pour new oil of specified amount to supply port [1].

Oil type: Gear oil SAE #90

Amount: 1.1 Liter

Replace: Every 300 hours

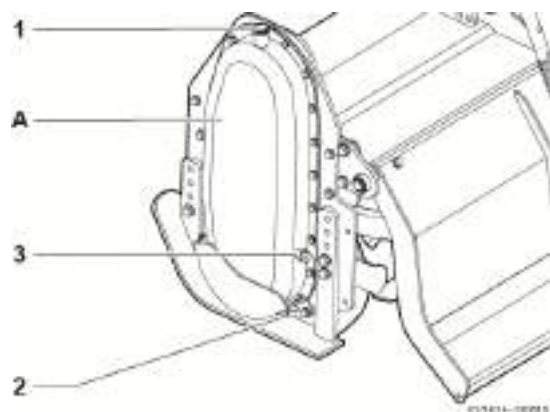

[A] Chain case
[1] Supply port
[2] Drain plug
[3] Oil level plug

7-4. Replacing bearing case R oil

<Oil replace>

Remove the protector R [A] of the bearing case R.
Remove and wipe off oil.
Reinstall the protector R [A].
Remove the plug [1] and put specified amount of oil.

Oil: Gear oil SAE #90

Amount: 0.1 Liter

Replace: Every 300 hours

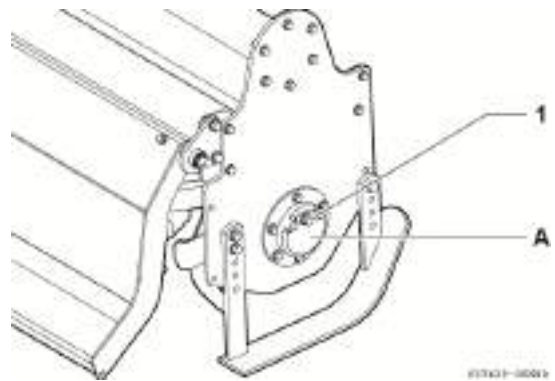

[A] protector R

[1] Plug



IMPORTANT

It is difficult to check oil level of the bearing case R.
Be sure to replace oil periodically, every 300 hours.
If old oil is milky, O-ring of the protector or oil seal of rotary shaft may be damaged. Replace the damaged one immediately.

7-5. Grease and oil

Grease to the grease nipple or apply grease to the moving parts after every day work. If worked in the field with water, be sure to grease to the grease nipple to push out muddy water.

[A] Apply grease to moving part

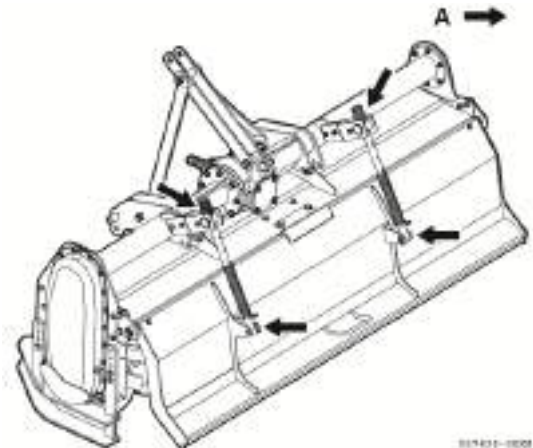

<PTO drive shaft>

- Separate the shaft and apply grease on sliding part.
- Apply grease to PTO shaft and rotary pinion shaft.
- Apply grease on lock pin and universal joint moving parts.

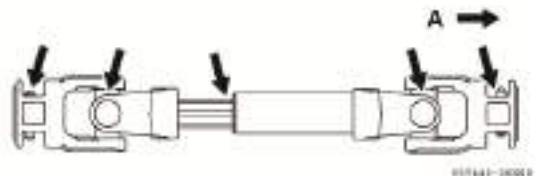

IMPORTANT

- If worked in the field with water, be sure to apply grease to remove dirty grease or it may cause rusting.

7-6. Replacing tilling blade

It is the time to replace tilling blade when the blade is worn out and the tip of the blade [A] is sharpened as the right figure shows. It is suggested to replace blade in a little earlier time for better efficiency work. It is too late to replace bent or broken blade.

* Refer to "[4], 4-5. Installing tilling blade" for replacing blade.

New blade

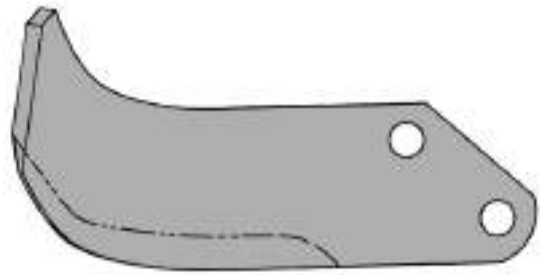

To be replaced

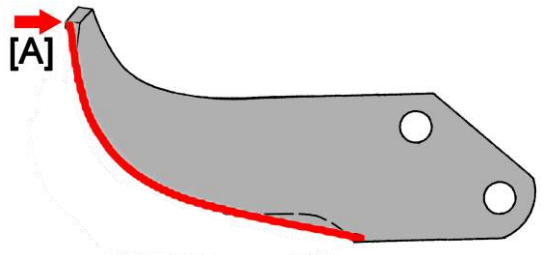

[A] When this part is sharpened as the figure shows, the blade must be replaced.

[8] Others

Specification

Model		RH170	RH190
Applicable tractor		EF393T	EF494T
Overall length	(mm)	845	
Overall width	(mm)	1875	2075
Overall height	(mm)	1030	
Weight	(kg)	300	325
Drive system		Side drive	
Hitch type		Standard 3 point hitch	
Tilling width	(mm)	1665	1870
Tilling blade	Quantity	48 blades (L24, R24)	54 blades (L27, R27)
	Rotation diameter at blade tip	(mm)	425
	Installing type		Flange

Note:

All technical data, measurement and weight are approximate, and the manufacturer has the right to make alteration without prior notice.

YANMAR CO., LTD.
[http:// yanmar.com](http://yanmar.com)

OPERATOR'S MANUAL

RH170/RH190

Copyright © 2013 YANMAR CO., LTD. All Rights Reserved.
This manual may not be reproduced or copied in whole or in part, without the written consent of YANMAR CO., LTD.

<https://tractormanualz.com/>

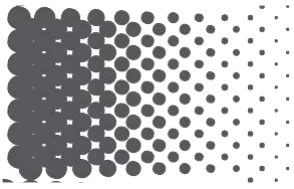

ROTARY TILLER

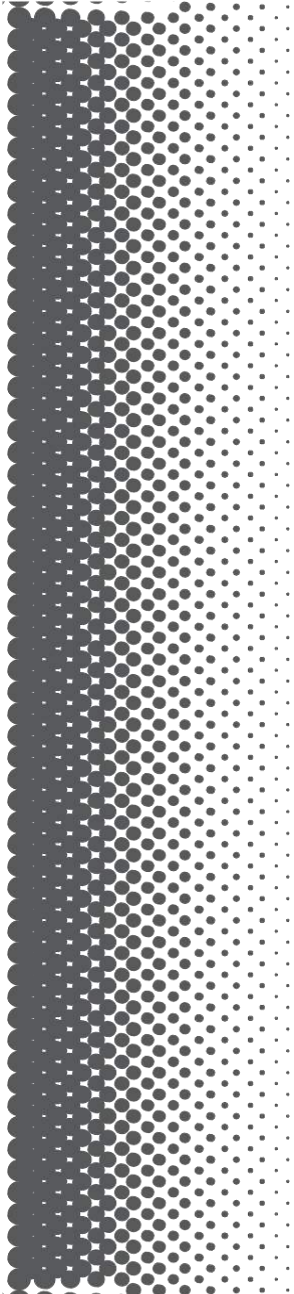

YANMAR

YANMAR CO., LTD.

<http://yanmar.com>

0A051-B00200
Sep. 2013
PRINTED IN JAPAN

<https://tractormanualz.com/>