



***NORDBERG LT105/LT105S
INSTRUCTION MANUAL
140561-B***

This instruction manual is valid for diesel engine driven Nordberg LT105/105S manufactured by Metso Minerals.

Nordberg LT105/105S is a portable jaw crusher unit, which is intended to be used in recycling crushing applications in crushing plants.



Because of the continuous development of the product, the manufacturer reserves a right to alter the technical specifications written in this manual, without any advance information.

This is the second edition published in February 2002 in Tampere, Finland.

Manufacturer:

Metso Minerals (Tampere)
Oy
P.O. Box 306
33101 Tampere
Finland

Tel +358-204-84 142

Fax +358-204-84 143

This instruction manual is intended to assist owners and users of Nordberg products in the proper use of the equipment.

It includes important references to safe, proper and economical operation of the equipment. Following these instructions will help to avoid possible danger, reduce repair costs and breakdowns and to increase the reliability and life of the equipment.

This manual must be complemented by those instructions necessary because of existing national mandatory rules relating to accident prevention and environmental protection.

A copy of this manual must be kept at the equipment's location and made available to the operators as required.

In addition to this manual and accident prevention regulations mandatory in the country of use and at the equipment's place of operation, generally recognized rules for safe and professional operation must be observed.

This instruction manual must be read and used by each person who works with the equipment, typically:

- operations, including installation, startup, operation, application engineering, materials handling, site labour, environmental engineering and safety departments.
- maintenance, including inspection and repair.
- transport, materials handling and rigging.

Note that this instruction manual contains information and instructions on alternative and optional equipment. Normally the machines have only some of them. Before maintaining and servicing, find out which alternative and optional equipment your machine has.

See separate instruction manuals for more detailed instructions when servicing the main components.

There may be optional equipment which have separate instruction manuals. Those manuals must be read and used by each person who works with the equipment.

Chapter 2

Security

SAFETY

2.1	WARNING SYMBOLS	2-1
2.2	PERSONNEL SAFETY	2-1
2.3	BEFORE STARTING CHECK	2-2
2.4	START UP SAFELY	2-3
2.5	REPORT A DEFECTIVE MACHINE	2-3
2.6	STOPPING SAFELY	2-3
2.7	TIPS FOR SAFE MAINTENANCE	2-3
2.8	READ AND UNDERSTAND	2-3
2.9	WARNING TAGS	2-3
2.10	LOCKOUT ELECTRICAL SERVICE	2-3
2.11	CLOTHING - SAFE PRACTICE	2-4
2.12	ALCOHOLIC BEVERAGES AND MEDICATION	2-4
2.13	WORK AREA	2-4
2.14	EQUIPMENT	2-4
2.15	FIRE HAZARDS	2-4
2.16	PRESSURIZED SYSTEMS - HYDRAULIC OR AIR	2-5
2.17	REPORT NECESSARY REPAIRS	2-5

2.1 WARNING SYMBOLS

The following symbols for particularly important instructions are being used in the instruction manual:

Reference



Refers to economical operation of the equipment.

Attention



Particular attention must be given to prevent possible incorrect or dangerous operating situations from occurring.

Danger



Particular attention must be given to prevent accidents or damage to personnel and/or property.

2.2 PERSONNEL SAFETY

This portion of the instruction manual is intended to illustrate only basic safety procedures. Additional precautions may be necessary for the safe operation of a Crusher. The information contained in this manual is not intended to replace safety codes, insurance requirements, federal, state and local laws, rules and regulations.

SAFETY of the operator and maintenance personnel is of prime concern. These paragraphs

are presented as a helpful guide to construction equipment personnel and shows some of the daily work problems which they may encounter.

It is the responsibility of the operator to know what specific requirements, precautions and work area hazards exist and to discuss them with his supervisor. A common understanding should be reached by all personnel to assure safe performance in operating the equipment.

The operator is the key to safe job performance and should study these safety tips to be aware of basic safety precautions to help prevent serious injury and damage to property.

STOP ACCIDENTS BEFORE THEY STOP YOU!

In order to alert you, the user, and those entrusted as operators and maintenance personnel, dangerous or hazardous operations are shown in this instruction manual with **WARNING** notes.

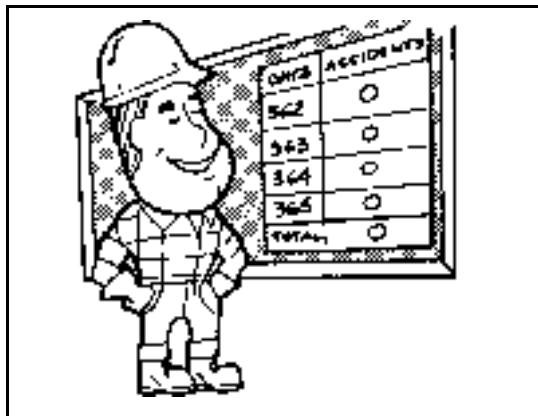

The safest machine must still be operated with care and with knowledge of its performance capabilities. The most comprehensive safety program must still be followed.

Remember that on any job, YOU are the key to safety. Good safety practices not only protect the men around you, they are your own best protection. Study this manual and any manufacturer's operator's manuals covering your specific equipment. Read all warning and caution instructions. Practice safe operation.

INSIST THAT YOUR FELLOW WORKERS DO, TOO. BE ALERT TO POSSIBLE HAZARDS BEFORE THEY CAUSE TROUBLE, AND REMEMBER . . . SAFETY IS UP TO YOU!!!

DO YOU KNOW YOUR EMPLOYER'S SAFETY PROGRAM?

Company safety records show that the greatest percentage of accidents are caused by disregard of simple safety rules. Know-observe!-the overall program . . . and consult your supervisor for specific instructions when starting a job.

ARE YOU DRESSED PROPERLY FOR THE JOB?

You may need any number of special items - safety hat, safety shoes, safety glasses, goggles, heavy gloves, ear protective devices, etc., - for your own protection. Find out what items are required and wear them!

Loose clothing can catch in moving parts. Keep sleeves buttoned, jackets belted and wear your special safety equipment. Keep warm without restricting your movement. Wrist watches and rings can be dangerous. Keep your pockets free of objects which may fall out.

DO YOU UNDERSTAND YOUR MACHINERY?



READ THE MANUAL furnished with your equipment to learn its operating and maintenance characteristics, capacities and limitations. Learn the location and function of ALL controls, indicators, warning devices and caution instructions.

DO YOU HAVE KNOWLEDGE OF WORKING AREAS?

Learn - beforehand as much about your working area as possible:

Be a good housekeeper . . . keep the floor clean, free of oil, grease, rags, cables, chains, buckets, rocks and other hazards. Keep loose parts in a tool box. Use only non-flammable solutions for cleaning.

Know the weight limitations for any floors on which you will operate.

Know the clearances in the work area. A little time spent checking side and overhead clearances, including power lines, can save a lot of trouble later.

Be careful of dust, smoke or fog, which may obscure your vision.

ARE YOU PREPARED FOR EMERGENCIES?

Plan ahead - stay alert - operate sensibly - and you will avoid both having and causing personal injury and accidental equipment damage. If a careless moment does cause an emergency - react quickly with the tools and skills at hand. Know the location of and how to use a fire extinguisher and a first aid kit.

Know where to get prompt assistance.

An emergency calls for fast action.

DON'T STOP YOUR SAFETY PROGRAM WITH THESE GENERAL RULES. BE EQUALLY CONSCIOUS THAT SPECIFIC WORKING CONDITIONS AND YOUR PARTICULAR EQUIPMENT - CAN REQUIRE ADDITIONAL PRECAUTIONS.

2.3 BEFORE STARTING CHECK

Equipment not properly prepared for operation is unsafe equipment. Run a careful check at the beginning of your shift. If you find something that needs attention, **THINK TWICE** before deciding to "let it go this time". Even minor mechanical defects can lead to personal injury and accidents.

1. **DO NOT** allow unauthorized personnel to operate the Crusher!
2. **MAKE SURE** all guards and other protective devices are in place, secured and not damaged.
3. **CHECK** fluid systems: Are they at the correct level and completely leak free?

- CHECK every drain cock, valve and fitting to sure it is in place and secure
- Loss of pressure from low fluid levels may lead to serious hydraulic failures.
- CRUSHER SEIZURE from lack of oil or grease is a problem that may cause accidents.
- NEVER tamper with safety devices.
- CHECK the Crusher thoroughly for visual defects, such as leaks, worn hoses or loose parts.
- INSPECT your machine according to the operator's manual and your supervisor's instructions.
- BEFORE STARTING walk completely around your machine. Make sure there is no one next to under or on the machine. Warn any personnel nearby that you are starting up.

REPORT ANY DEFECTS TO YOUR SUPERVISOR

2.4 START UP SAFELY

- CHECK equipment for warning tags.
- FOLLOW the recommended starting procedure as outlined in Section 5 OPERATION.
- AFTER Crusher has been started, check all gauges and instruments to be sure that everything is operating properly.
- SHUT DOWN immediately if any improper readings are observed.
- TEST all controls for proper functioning.
- LISTEN for and report any unusual noises.
- RE-CHECK alarms or other warning and safety devices.
- DO NOT stand on the Crusher while the Crusher is running.
- DO NOT lean or place your hands on or against the tension spring while the Crusher is in operation.
- DO NOT take a chance with a defective machine. REPORT IT TO YOUR SUPERVISOR.

2.5 REPORT A DEFECTIVE MACHINE

Inspect your machine daily . . . check for loose, worn or damaged parts. Report or correct any unsafe conditions immediately . . . and do not operate the machine until they have been corrected.

Even a minor defect can become serious . . . report any machine defects to your supervisor.

2.6 STOPPING SAFELY

Be sure Crusher is stopped before . . . cleaning, servicing, lubricating . . . checking belt tension . . . removing housing covers . . . working on the hydraulic system . . . making repairs . . . or attempting to clear a plugged cavity. MAKE NO CHECKS, ADJUSTMENTS OR REPAIRS OF ANY KIND WHILE CRUSHER IS IN OPERATION.

2.7 TIPS FOR SAFE MAINTENANCE

Perform maintenance with care.

2.8 READ AND UNDERSTAND

- Instruction manual furnished with the Crusher, especially Section 5, OPERATION.
- Instructions for inspection and maintenance located in Section 5 OPERATION and 7 PERIODICAL MAINTENANCE.
- Warning and caution plates provided on the machine.
- Warning and caution notes in the instruction manual.
- Lubrication guides for periodic servicing in Section 6, LUBRICATION.

2.9 WARNING TAGS

Before working inside a Crusher, be sure to tag and lockout the electrical controls so no one else will start it.

Attach warning tags to prevent accidents:

- If Crusher is unsafe for operation.
- If controls are being serviced.
- If machine is being repaired.

2.10 LOCKOUT ELECTRICAL SERVICE

- Always lockout all electrical controls before performing any type of maintenance work

on the Crusher.

2. Provide each maintenance man with his own personal padlock and ONE key.

2.11 CLOTHING - SAFE PRACTICE

1. KEEP HANDS AND CLOTHING AWAY FROM MOVING PARTS. Do not take chances by wearing loose sleeves, floppy ties, watches and rings.
2. WEAR EYE PROTECTION when handling fuel, cleaning fluid, oil or brake fluid. THESE MATERIALS CAN DAMAGE YOUR EYES.
3. WEAR A RESPIRATOR when required.
4. WEAR SAFETY GLASSES when drilling, grinding or hammering metal.
5. KEEP YOUR POCKETS FREE of objects which can fall out and into machinery.
6. WEAR HARD HAT AND SAFETY SHOES, when required.
7. WEAR GLOVES to protect your hands when changing cables.
8. WEAR SAFETY GLASSES AND PROTECTIVE CLOTHING when using high pressure air.
9. WEAR GOGGLES AND PROTECTIVE CLOTHING when handling molten metals; zinc, babbitt, lead, etc.
10. WEAR EAR PROTECTIVE DEVICES when required or REDUCE exposure time as required.

2.12 ALCOHOLIC BEVERAGES AND MEDICATION

1. DO NOT use alcoholic beverages before coming to work or while on the job.
2. BEWARE of medicines, tranquilizers or other drugs which can make you sleepy or less alert.

2.13 WORK AREA

1. PROMOTE GOOD HOUSEKEEPING, keep the floor clean and dry, free of debris and tools. Oily and wet floors, steps and hand rails are slippery. In winter watch out for ice and snow. Wet spots, especially near

electrical equipment, are dangerous.

2. DO NOT let material lay and build up on or around the Crusher.
3. 3STORE dangerous fluids in a suitable place - away from unauthorized personnel. ALLOW NO SMOKING IN THE AREA!
4. NEVER start a diesel or gasoline engine within an enclosed area unless there is adequate ventilation. Exhaust fumes can kill!

2.14 EQUIPMENT

1. Use the proper tools; handle tools and heavy parts sensibly.
2. Keep all tools and equipment free of dirt, oil and grease. Do not drop or toss them.
3. Use hoisting equipment for heavy lifting. Save your back.
4. Lower parts, do not drop them.
5. To prevent slipping, wipe hand levers and knobs clean of oil or grease.
6. Do not use sheaves with cracked rims or spokes.
7. Check for missing, cracked or frayed V-belts.
8. Check for broken, defective or missing parts and replace them. Keep equipment clean and free of dirt and oil so you can spot loose or defective parts.
9. When using cables to move a load, be sure cables are of adequate size and replace any worn, badly frayed, broken or kinked ones. Check end connections for wear.

2.15 FIRE HAZARDS

1. DO NOT smoke while refueling - or when handling fuel containers.
2. SHUT OFF engine when refueling - and use extra caution if engine is hot.
3. WHEN pouring fuel into the tank, ground the funnel or spout against the filler neck to avoid static electric spark.
4. DO NOT use gasoline or diesel fuel for cleaning parts. Good commercial, non-flammable solvents are preferred.

5. DO NOT smoke while using cleaning solvents.
6. DO NOT let greasy, oily rags accumulate in poorly ventilated area. Store oily rags and other combustible material in a safe place.
7. NEVER use an open flame to check fuel, battery electrolyte or coolant levels . . . or to look for hydraulic leaks anywhere on the equipment. Use a flashlight!
8. KNOW where fire extinguishers are kept - and how they operate - and for what type of fire. Check regularly - at least monthly - to be sure it is in the working area.

2.16 PRESSURIZED SYSTEMS - HYDRAULIC OR AIR

1. Relieve ALL pressure before opening or removing any hydraulic or air pressure lines, valves, fittings, etc.
2. Check for worn hoses or damaged lines.
3. High pressure oil can be dangerous.

USE QUALITY PARTS

A replacement part for any item should always be of comparable **SIZE, TYPE AND QUALITY** - as the part being discarded.

2.17 REPORT NECESSARY REPAIRS

If your daily check uncovers any item that need attention - repair, replacement or adjustment - **REPORT IT NOW!**

The most minor defect could result in more serious trouble - **IF THE MACHINE IS OPERATED.**

Only perform the work you're authorized to do. Do not attempt repairs you do not understand.

Only work on equipment you thoroughly understand - a pressure-loaded part, if carelessly released could injure anyone in its path.

Remember you are entrusted with the operation and maintenance of a highly valuable piece of equipment **TREAT IT AS SUCH!**

Chapter 3

Main components

MAIN COMPONENTS

3.1 MAIN ASSEMBLY	3-1
3.2 DIESEL ENGINE	3-2
3.3 TRACKS	3-2
3.4 CRUSHER	3-2
3.5 FEEDER	3-2
3.6 MAIN CONVEYOR	3-2
3.7 SIDE CONVEYOR (OPTIONAL)	3-2
3.8 MAGNETIC SEPARATOR (OPTIONAL)	3-2
3.9 HYDRAULIC VALVE LOCATION	3-3
3.10 HYDRAULIC SETTING CONTROL (OPTIONAL)	3-4
3.11 FEED HOPPER FOLDING	3-4
3.12 ENGINE MODULE	3-5
3.13 HYDRAULIC TANK	3-7

3.1 MAIN ASSEMBLY

- 1. Diesel engine
- 2. Tracks
- 3. Crusher
- 4. Feeder
- 5. Main conveyor
- 6. Side conveyor (optional)
- 7. Magnetic separator (optional)

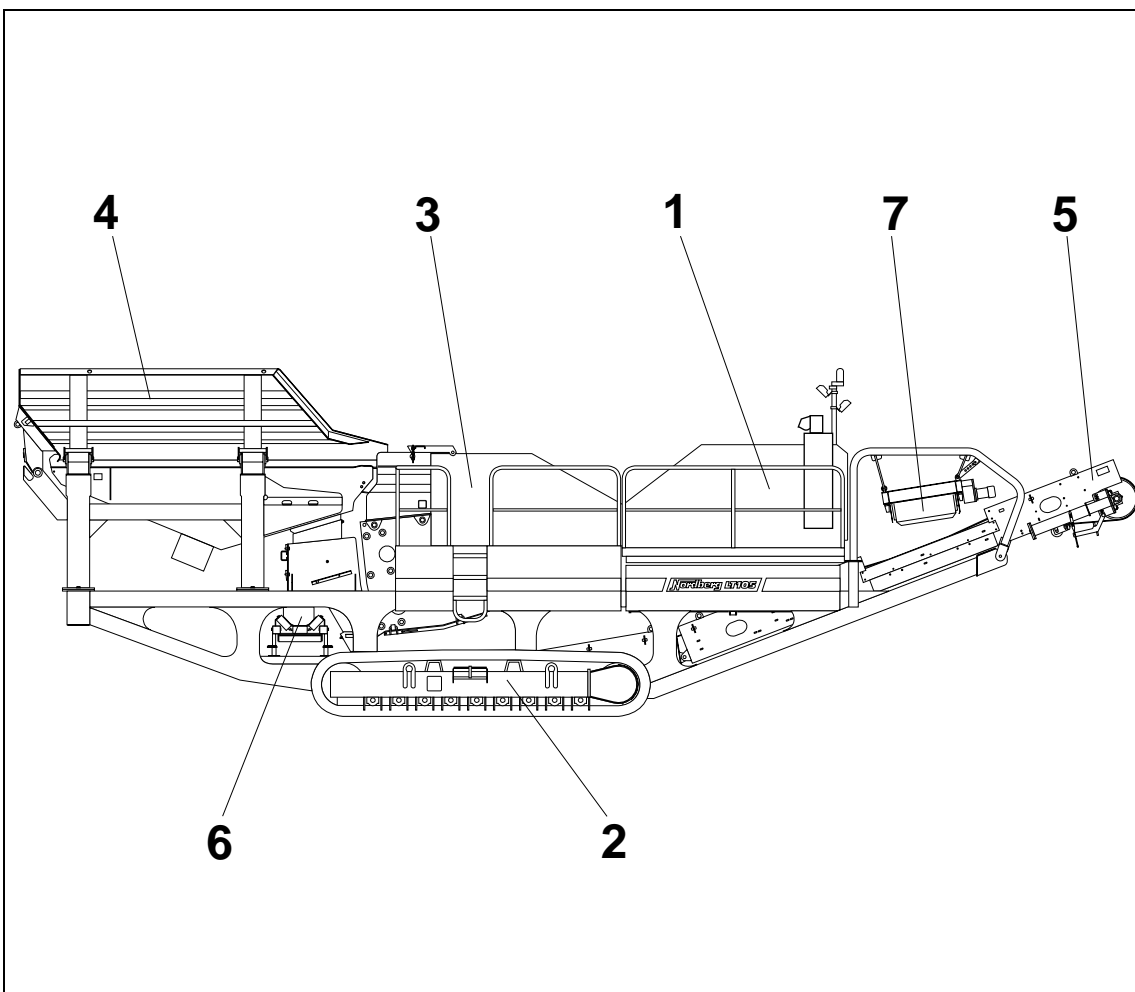

Figure 3-1 Main assembly

3.2 DIESEL ENGINE

The operating power of the LT105 is generated from the Caterpillar diesel engine. The engine runs the hydraulic pumps.

3.3 TRACKS

The LT105 moves with the tracks. The tracks ensure safe and fast movements of the machine even in the rough terrain.

3.4 CRUSHER

The Nordberg C105B jaw crusher is the heart of the LT105. The crusher crushes the feed material into smaller pieces.

3.5 FEEDER

The feeder ensures even and continuous material flow into the crusher. The feed material smaller than the opening of the feeder grizzly goes through the grizzlies passing the crusher. This increases the capacity and prevents material packing in the crusher.

3.6 MAIN CONVEYOR

The main conveyor transfers the crushed material from the crusher to the stock pile or to the next process.

3.7 SIDE CONVEYOR (OPTIONAL)

The optional side conveyor transfers the material that has passed the crusher through feeder grizzlies to the stock pile beside the machine.

3.8 MAGNETIC SEPARATOR (OPTIONAL)

The optional magnetic separator is installed above the main conveyor. It separates magnetic objects from the crushed material and transfers those to a separate pile beside the machine.

3.9 HYDRAULIC VALVE LOCATION

- | | |
|------------------------------------|-------------------------------------|
| 1. Pilot valve LS-pressure | 11. Side conveyor extension, in/out |
| 2. Pilot valve, fast speed | 12. Main conveyor turning, up/down |
| 3. Main conveyor | 13. LS-pressure gauge |
| 4. Hydraulic outlet | 14. Engine coolant drainage |
| 5. Magnetic separator | 15. Engine oil drainage |
| 6. Left track | 16. Hydraulic outlet (PTO) |
| 7. Right track | 17. Hydraulic oil drainage |
| 8. Feeder | |
| 9. Side conveyor / hand valves | |
| 10. Side conveyor turning, up/down | |

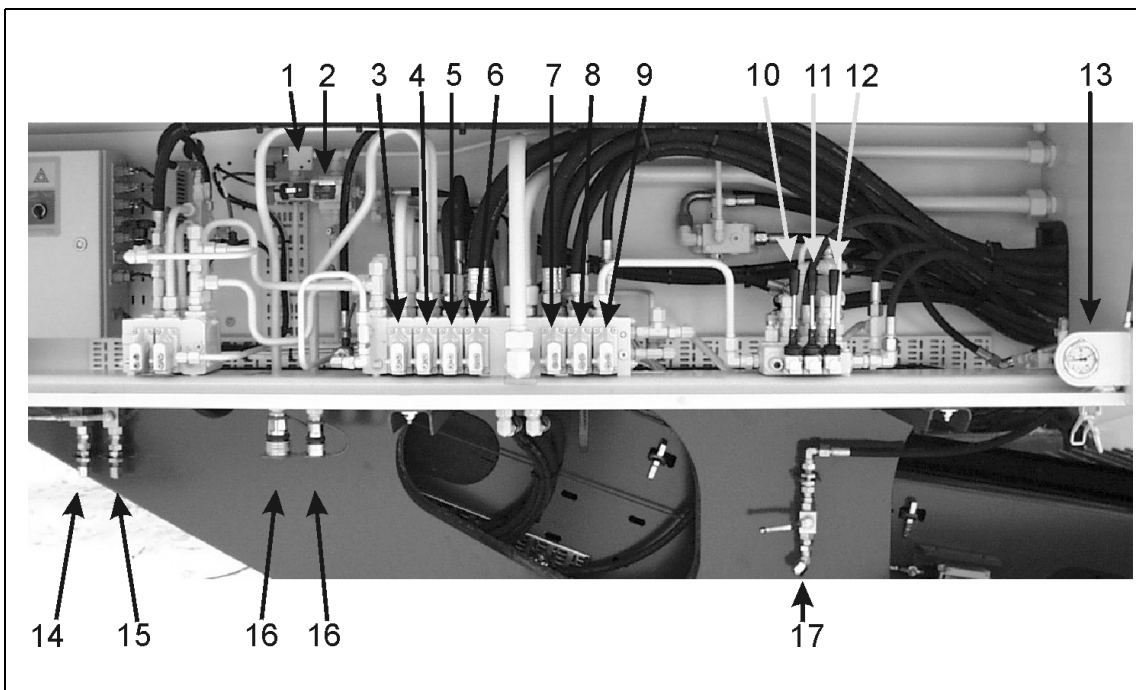
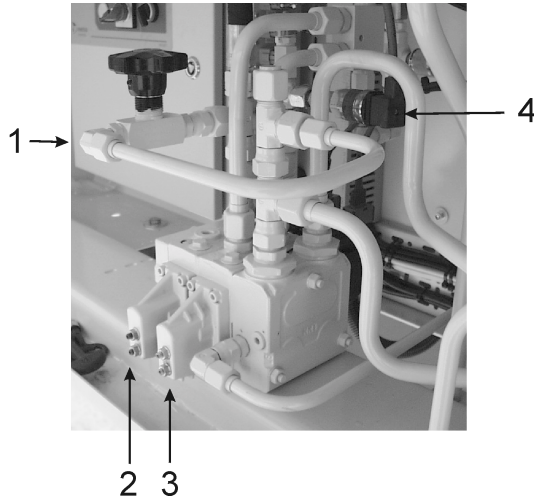

Figure 3-9 Hydraulic valve location

3.10 HYDRAULIC SETTING CONTROL (OPTIONAL)

3.11 FEED HOPPER FOLDING



1. Manual valve
2. Adjustment wedge movement
3. Return rod pressurizing
4. Return rod pressure sensor

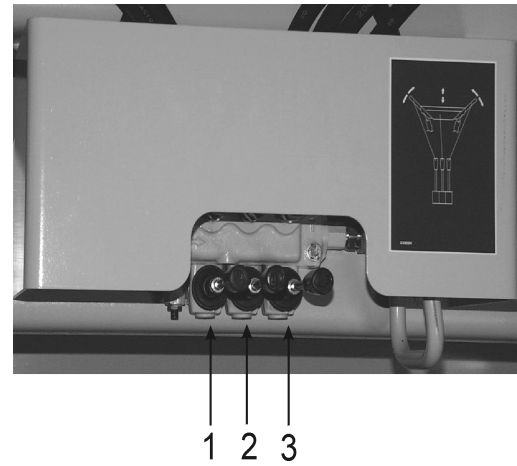

1. Left side wall lifting and lowering
2. Rear wall lifting and lowering
3. Right side wall lifting and lowering

3.12 ENGINE MODULE

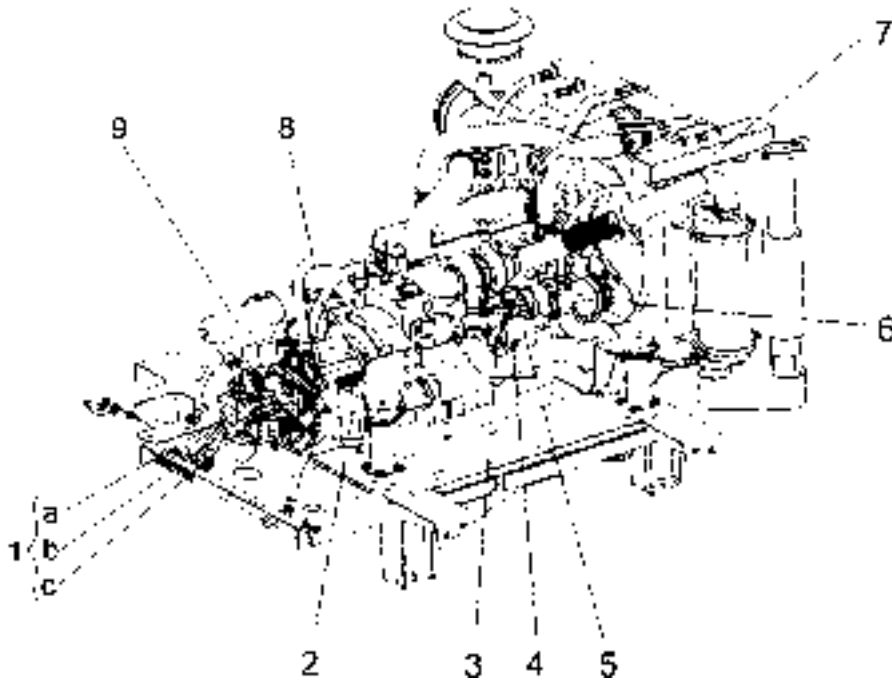

Figure 3-12 a) Engine module

- | | |
|--|------------------------------|
| 1. Measuring points of the crusher | 4. Oil fill port |
| a) Crusher drive pump return line (when crusher running to normal direction) | 5. Oil filter |
| b) Crusher drive pump charge pressure | 6. Charger |
| c) Crusher drive pump pressure (when crusher running to normal direction) | 7. Coolant expansion tank |
| 2. Engine primary fuel filter and water separator | 8. Crusher circuit filter |
| 3. Dipstick | 9. Hydraulic pressure filter |

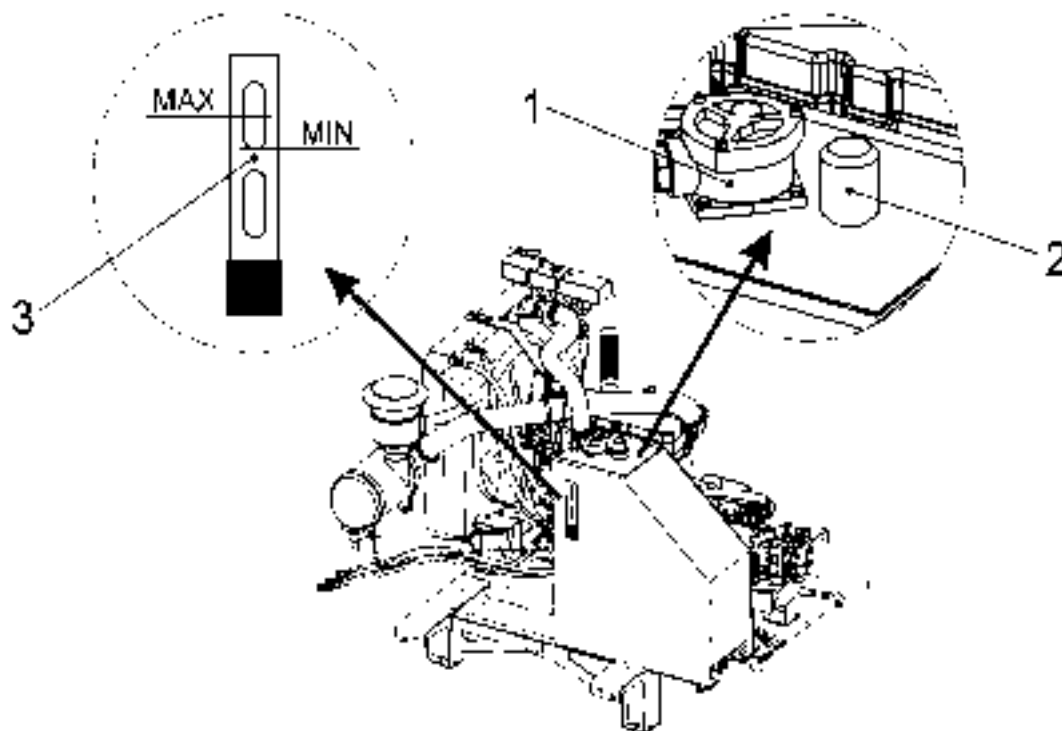

Figure 3-12 b) Engine module

- | | |
|----------------------------------|------------------------------|
| 1. Air cleaner | |
| 2. Air precleaner | |
| 3. Fuel filter, secondary | |
| 4. Mechanical fuel transfer pump | |
| 5. Engine electronics | |
| | 6. Hydraulic pressure filter |
| | 7. Coolant expansion tank |
| | 8. Batteries |
| | 9. Crusher circuit filter |

3.13 HYDRAULIC TANK

1. Hydraulic return filter
2. Breather
3. Hydraulic oil sight glass



Chapter 4

Control panels

CONTROL PANELS

4.1 OPERATING PANEL SWITCHES/BUTTONS.....	4-1
4.2 DRIVE CONTROL BOX.....	4-2
4.3 REMOTE CONTROL.....	4-3
4.4 HYDRAULIC MODULE CENTER.....	4-4
4.5 IC500 CONTROL SYSTEM.....	4-5

4.1 OPERATING PANEL SWITCHES/BUTTONS

- 1. Emergency stop
- 2. Lubrication unit
- 3. Radio key
- 4. Water pump
- 5. Display
- 6. Process ON
- 7. Key switch
- 8. Signal horn
- 9. Process OFF
- 10. Work light

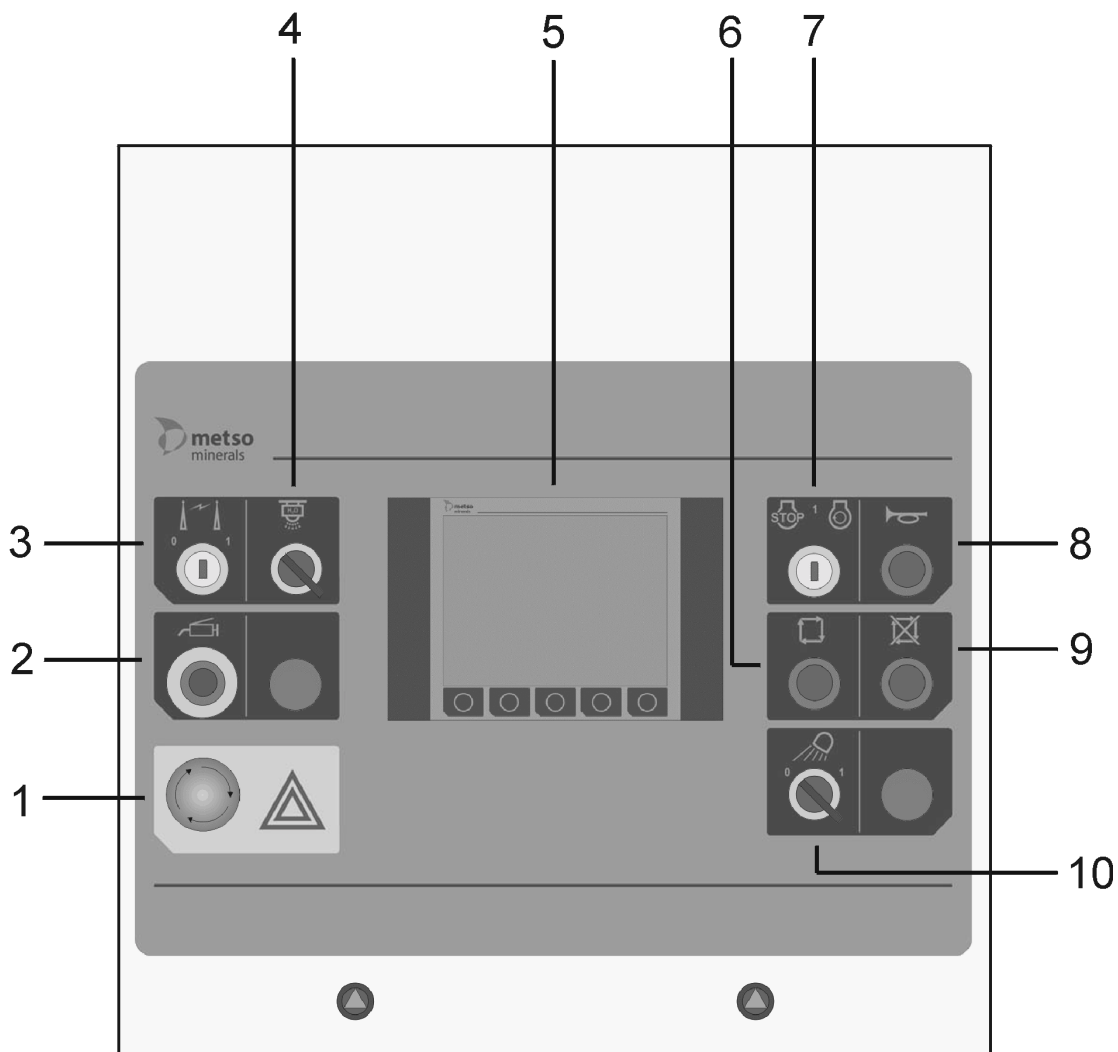

4.2 DRIVE CONTROL BOX

4.2.1 DRIVING CONTROLS

1. Track, left-hand
2. Track, right-hand
3. RPM of diesel engine
4. Emergency stop

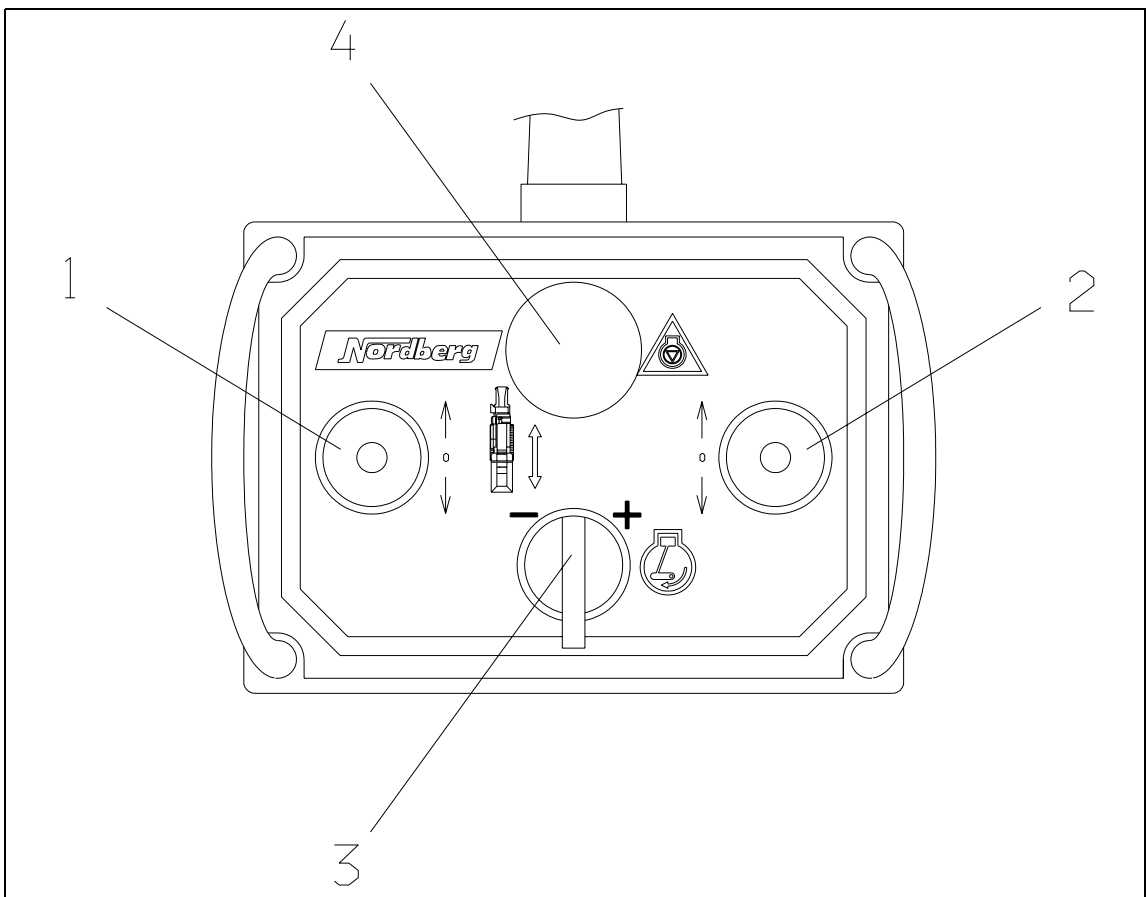

4.3 REMOTE CONTROL

- | | |
|-------------------|-------------------------------------|
| 1. Emergency stop | 7. Crusher start |
| 2. Feeder stop | 8. Crusher, counter-clockwise swing |
| 3. Feeder start | 9. Crusher, clockwise swing |
| 4. Feeder speed - | 10. Crusher setting - increase |
| 5. Feeder speed + | 11. Crusher setting - decrease |
| 6. Crusher stop | |

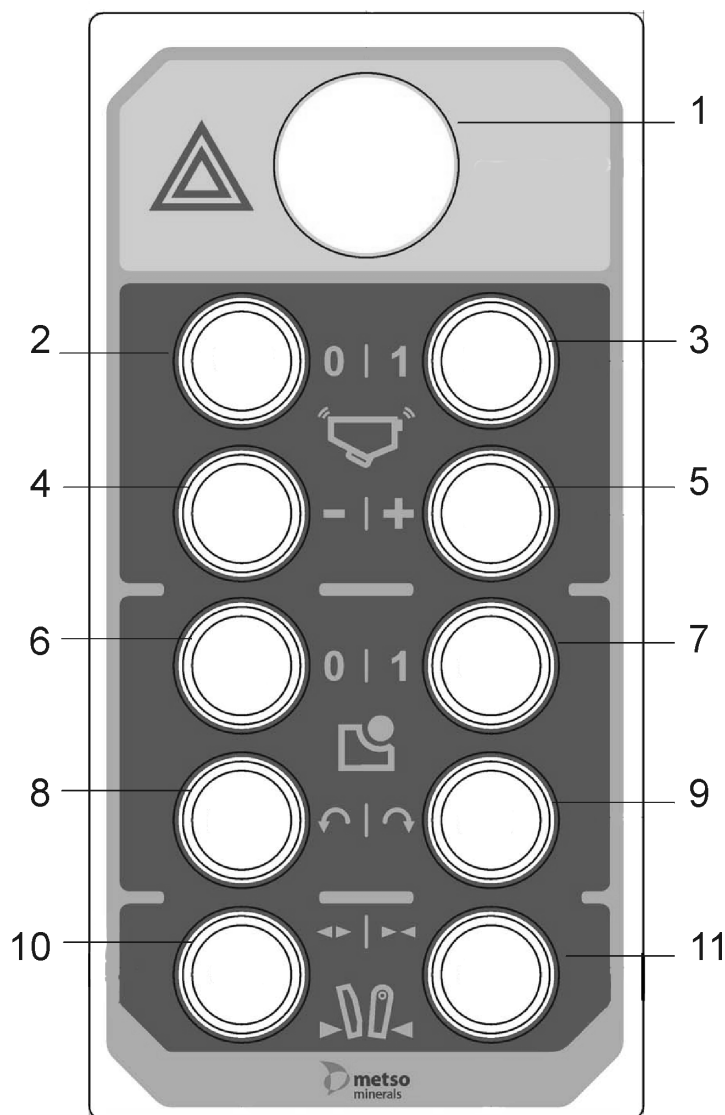

4.4 HYDRAULIC MODULE CENTER

1. Safety switch for conveyors
2. Fuel pump (optional)
3. Socket for screen module
4. Emergency stop
5. Hand valves

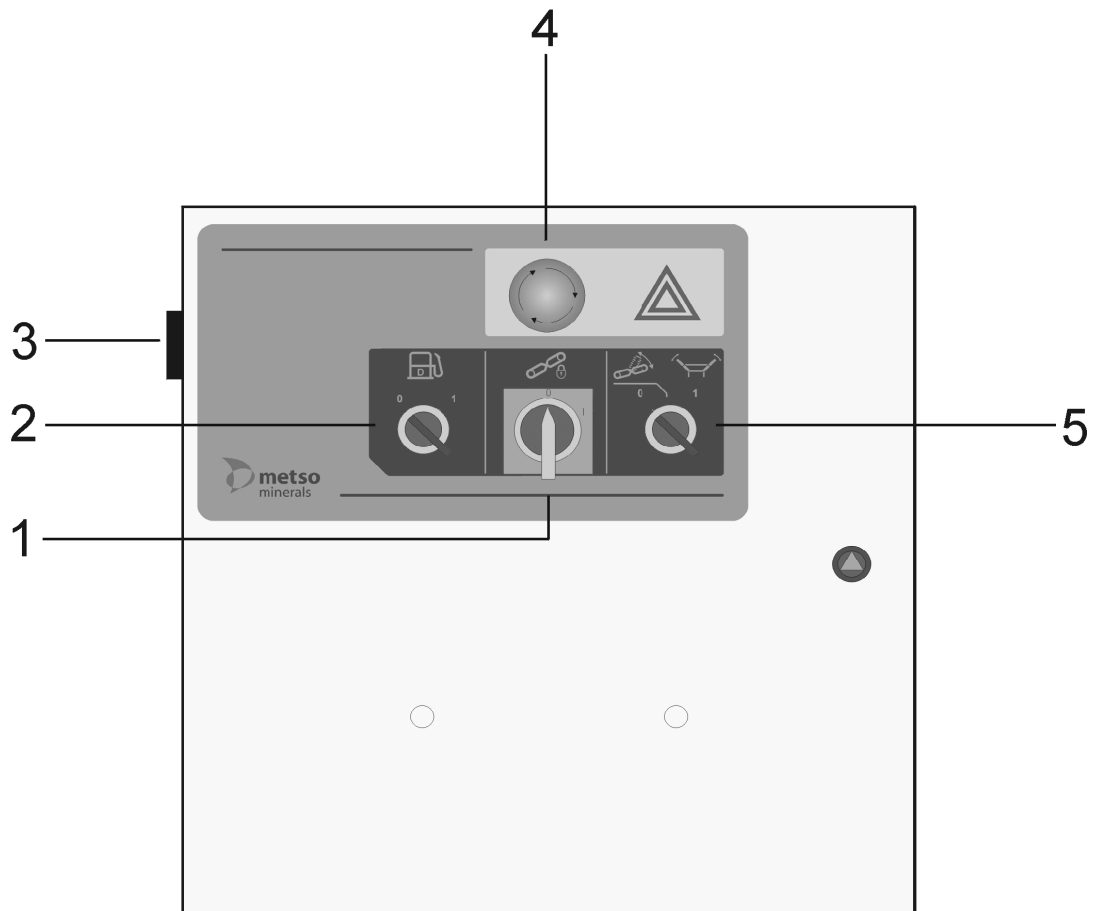

4.5 IC500 CONTROL SYSTEM

Please refer to a separate IC500 Instruction Manual for information on usage of this control system. The manual is attached to this Instruction Manual folder.

Chapter 5

Starting and stopping

STARTING AND STOPPING

5.1 BEFORE STARTING	5-1
5.2 STARTING THE DIESEL ENGINE	5-2
5.3 STOPPING THE DIESEL ENGINE	5-2
5.4 ADJUSTING DIESEL ENGINE RPM SPEED	5-2
5.5 EMERGENCY STOP	5-3

5.1 BEFORE STARTING

Check the condition of the machine:

- diesel engine coolant water
- diesel engine oil level

Turn the light pole up (figure 5.1.1), if necessary.

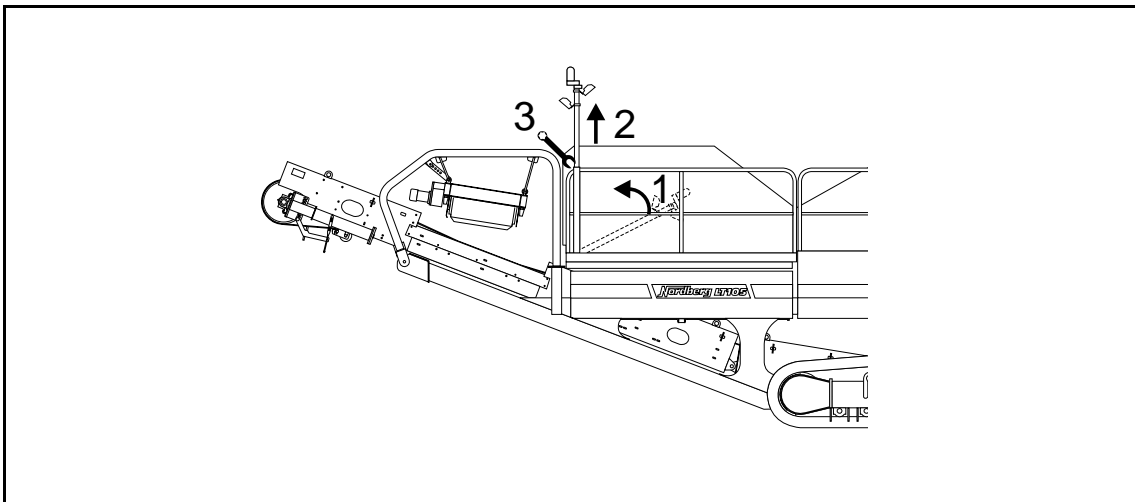

Figure 5.1.1 Turn the light pole up

Check the crusher V-belt tensions. The belt deflection is 22 mm (4/5") when force is 50 N (11 lb) (figure 5.1.2).

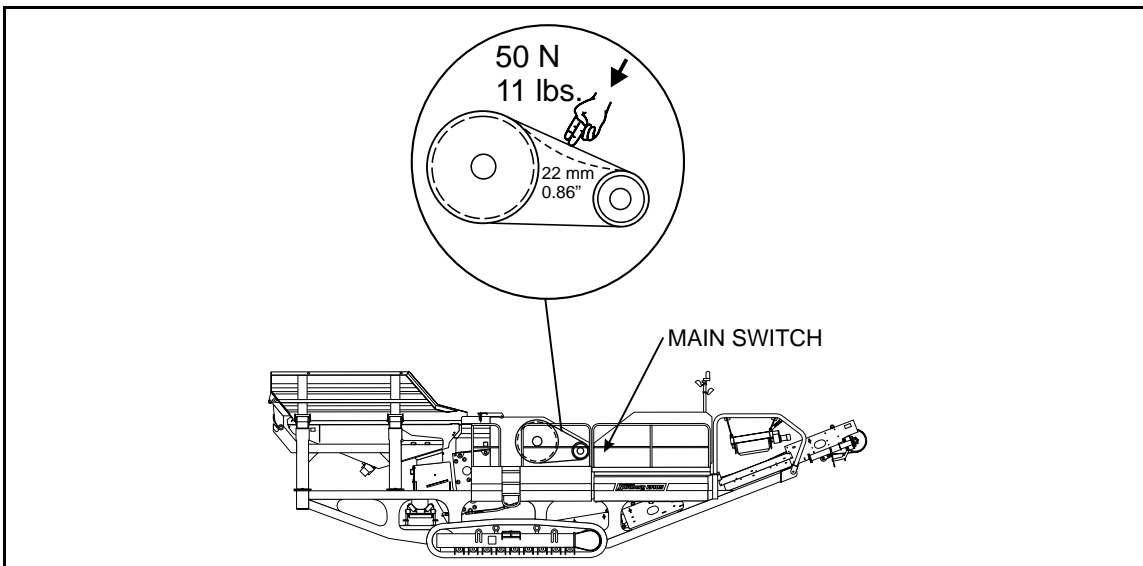

Figure 5.1.2 Check crusher V-belt tensions

Ensure that the machine is operated only in safe manner and when in good mechanical condition. Ensure that the machine is standing properly and will not overturn.

The operation of the machine must only be allowed, when all necessary protective and safety devices, e.g. guards, emergency stop devices, silencers, aspirators etc. are in place and in operating condition.

Before starting the machine, ensure that there are no persons in the area whose safety may be endangered! Walk around the machine and ensure that there is nobody on, by or below the machine. Warn everybody in the vicinity before starting.

5.2 STARTING THE DIESEL ENGINE

Start the diesel engine as follows:

4. Turn the key switch in the main control panel to ignition ON-position (ref. 4.1).
5. Wait until the unit centre display is visible. Reset possible display messages with F1 function key.
6. Turn the key switch to START position and hold it that way until the engine is running.

NOTE: Hold the key switch at start position until the diesel engine starts.

NOTE: If you use manual control, be especially careful. The fact is that manually activated device will not run until the diesel engine is running. But the device will start to operate immediately when the engine is started, if the manual control is on.

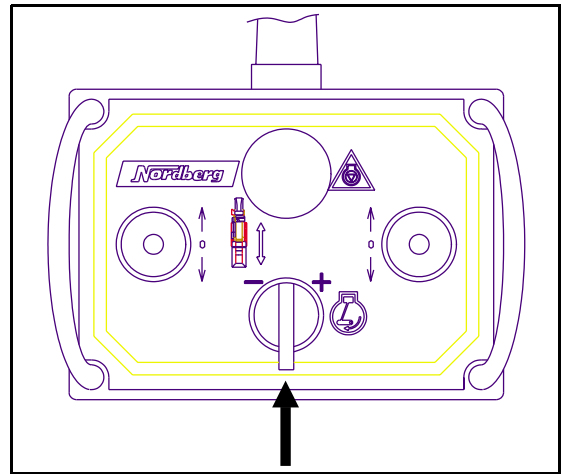

5.3 STOPPING THE DIESEL ENGINE

Stop the diesel engine by turning the key switch to "OFF" position.

NOTE: Before stopping the diesel engine, make sure that the engine idles for few minutes.

5.4 ADJUSTING DIESEL ENGINE RPM SPEED

The automatic control of the machine monitors and adjusts the diesel engine RPM during the start and the crushing process. During this time, the user cannot adjust the RPM speed. When the process is not running, the RPM speed of the diesel engine can be controlled with the RPM control switch located in the drive control box. If the machine has radio control (optional), the RPM speed of the diesel engine can be adjusted with radio control in the same way as with the drive control box.

5.5 EMERGENCY STOP

In case of emergency press emergency stop- button to stop the machine or the conveyor. The buttons are shown in the drawing 5.5.1. Operating of emergency relay ref. chapter 10.

EMERGENCY-STOP BUTTON	FUNCTION
A	Stops the machine
B	Stops the discharge conveyor
C	Stops the main conveyor

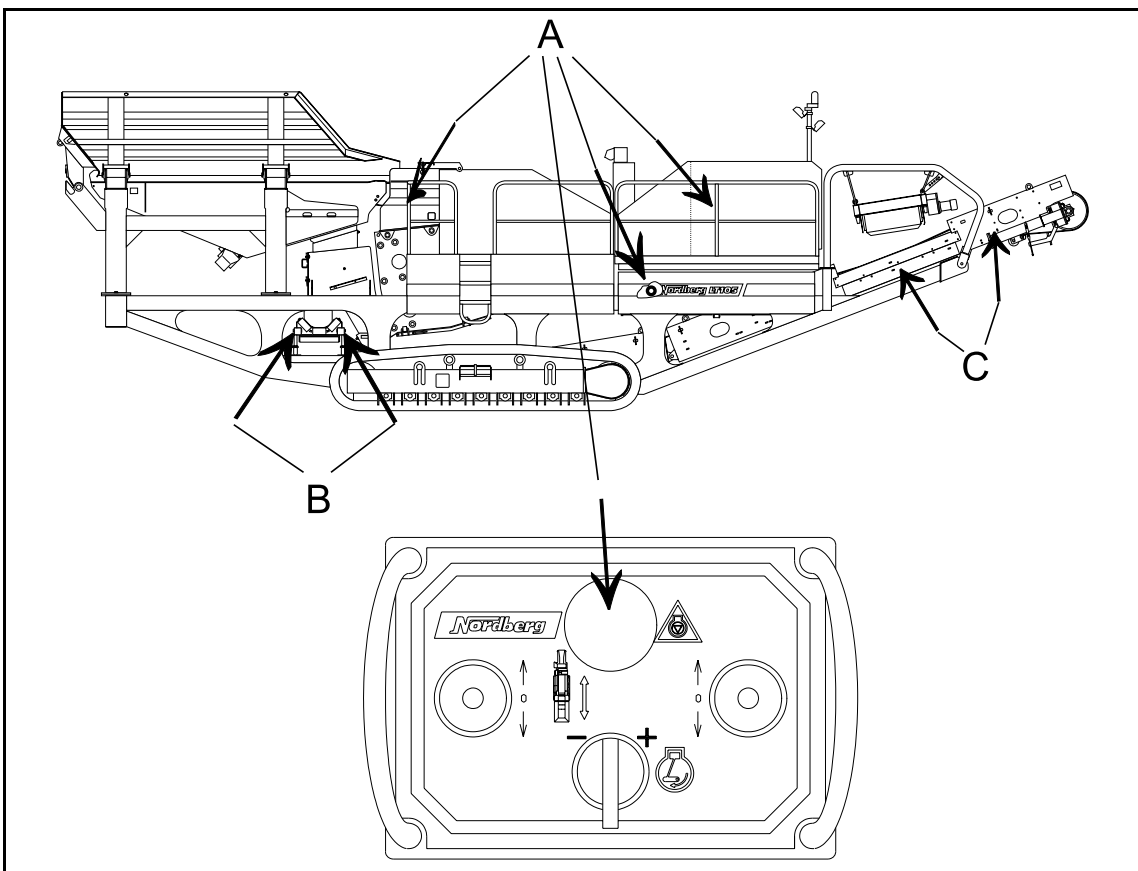

Figure 5.5.1 Location of the Emergency stop -buttons.

ENSURE THAT THE SUCTION VALVES OF THE HYDRAULIC TANK ARE FULLY OPEN

If the suction valves are not fully open, the position switch of the suction valves will cause emergency stop function.

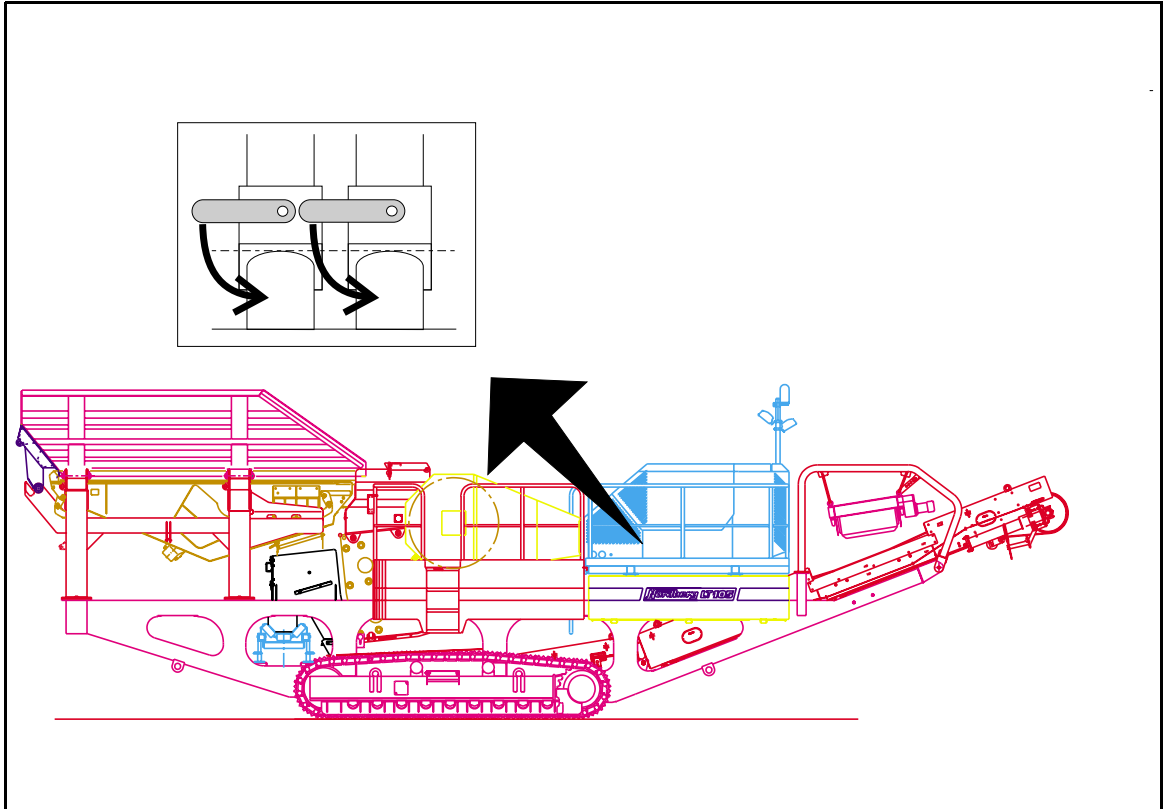

Figure 5.1.2 Ensure that the suction valves of the hydraulic tank are fully open.

Chapter 6

Transport

TRANSPORT

6.1 SAFETY WHILE TRACKING	6-1
6.2 TRACKING SPEED	6-1
6.3 DRIVING THE LT105	6-2
6.4 TRANSPORT FROM SITE TO SITE	6-4
6.5 DRIVING ON TO/OFF LOW LOADER / TRAILER	6-5

6.1 SAFETY WHILE TRACKING

Pay special attention to transport and moving of the unit because of its dimensions and weight.

Normally the LT105 can be moved on the site in its working position by driving on tracks.

Before driving make sure that

- the driving route is smooth enough.
- differences in altitude and road inclination do not prevent driving.

Whilst tracking the machine, the maximum inclination allowed is 5 degrees sideways and 15 degrees length ways.

Make sure that the load bearing capacity of the ground is at least 15,000 kg/m²(3072 lbf/sq f).

Start the engine as instructed in chapter 5.2.

6.2 TRACKING SPEED

The tracking speed varies according to the diesel engine rpm.

Low speed is selected when th engine runs idle.

Fast speed is active when engine speed is at the maximum.

6.3 DRIVING THE LT105

Drive the LT105 with the drive controls in the drive control box. If the machine has radio control (optional), the driving is also possible with radio control, in the same way as with the drive control box.

Plug the drive control cable into one of the cable connecting sockets (figure 6.3.1 and 6.3.2).

The Lokotrack can now be moved in either direction using drive control levers in the remote control unit (figure 6.3.2).



Always check the surroundings of Lokotrack before moving it.

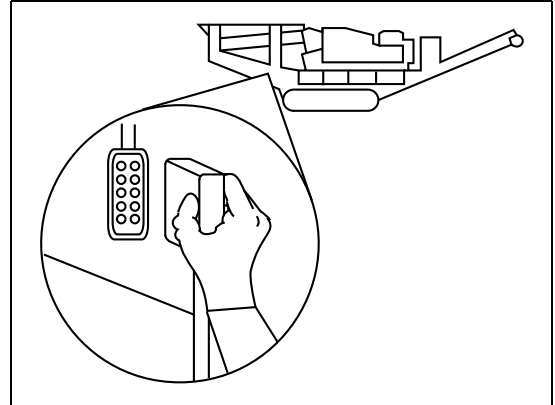

Figure 6.3.1 Plug the drive control cable into one of the cable connecting sockets

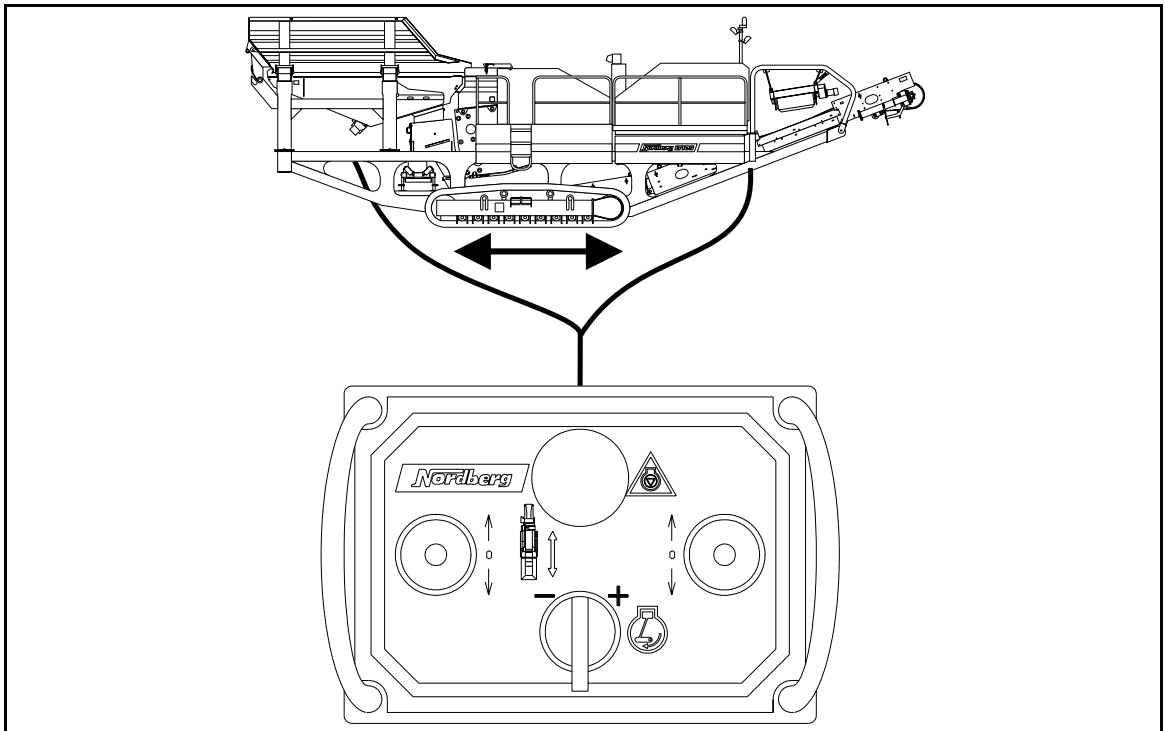

Figure 6.3.2 The LT105 can be moved in either direction using drive controls

NOTE: If manual valves selection switch is active, the track driving is prevented.



NOTE: Make sure that there is nobody in the area before driving. Avoid sudden and unpredictable moves while driving.

Driving speed can be regulated by adjusting the engine speed between min - max rpm, using the throttle.



NOTE: During longer moves (over 100 m / 328 ft) LT105 must be driven feeder end first. That is to keep the track chain tight and to prevent the chain from jumping over drive pulley teeth.

If no crushing is required, stop the engine as instructed in chapter 5.3.

If you start crushing, see section 5.2.

Some hints to make turning the LT105 easier:

- LT105 turns easier on hard than soft ground.
- If the LT105 can not be turned when driving uphill, drive a short way downhill turning the unit at the same time.

6.4 TRANSPORT FROM SITE TO SITE

When the LT105 is transported on public road, take care that it has the necessary permissions from authorities for special transport. Check the local regulations, as they vary in each country.

EQUIPMENT NEEDED

- Low loader, min capacity 40 t (44 st).

MEASURES BEFORE TRANSPORT

1. Turn down additional side walls of the feeder. (ref 7.4)

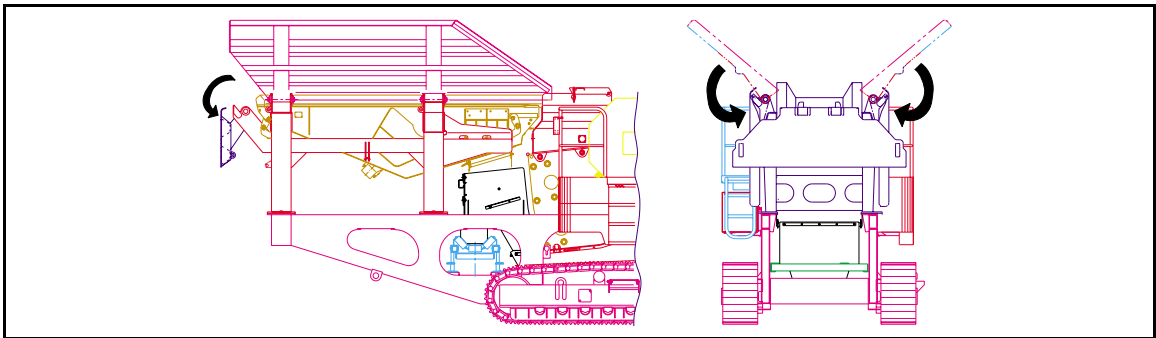

2. Turn the side conveyor up. (ref 7.4)

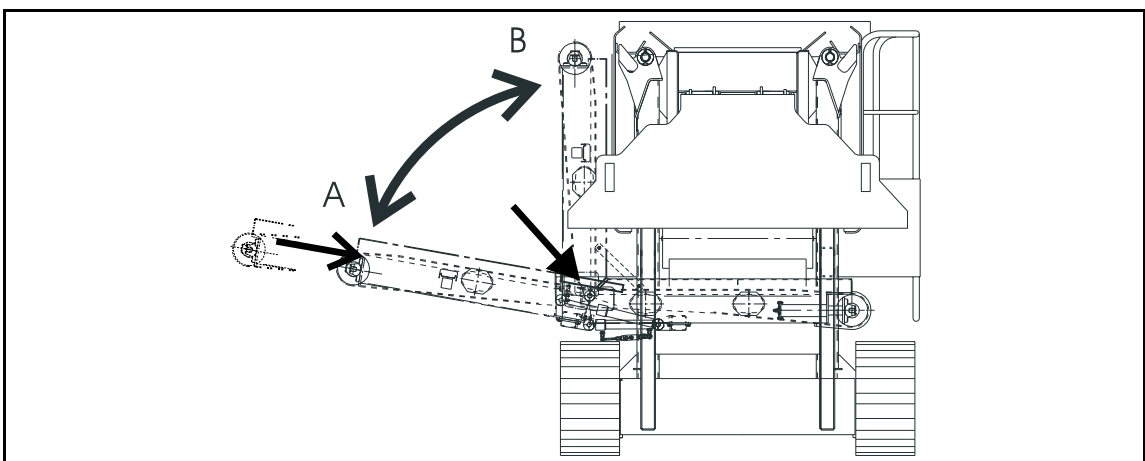

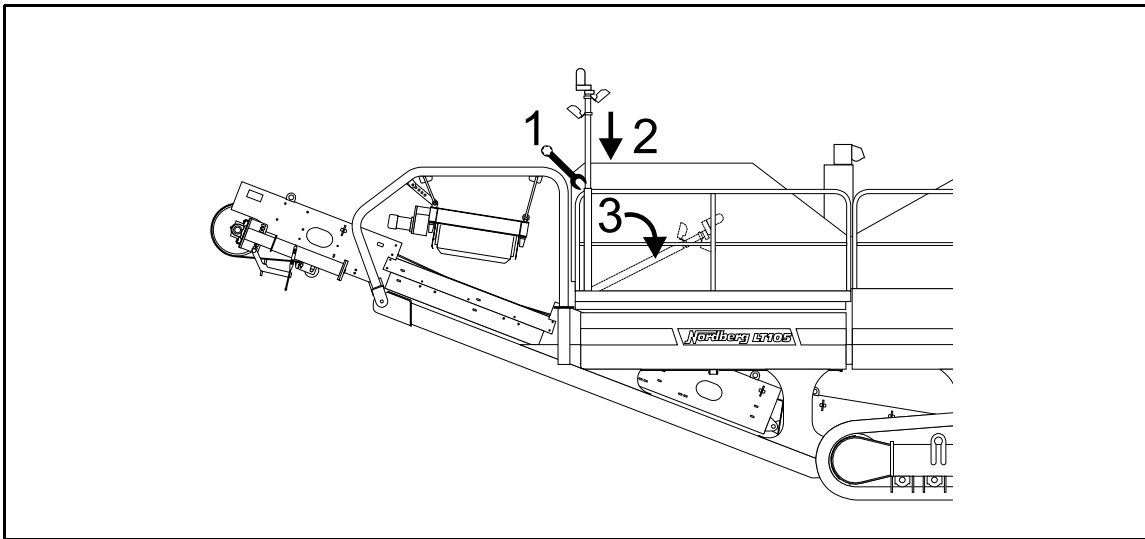

3. Place light pole into the transport position.
4. See 7.3.1 if needed.

6.5 DRIVING ON TO/OFF LOW LOADER / TRAILER

Drive LT105 onto and off loader/trailer very carefully.

Fix suitable ramp against the trailer so that the maximum inclination does not exceed 1 in 4 when driving the LT105 up onto the trailer.

The LT105 may be driven onto the trailer forwards or backwards depending on trailer type.

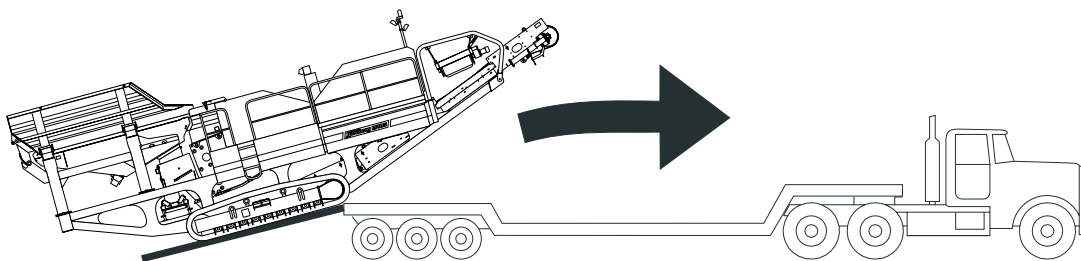

WEIGHT OF THE BASE UNIT (WITHOUT FUEL): LT105 35600 KG / 78480 LBS AND
LT105S 39600 KG / 87480 LBS

Total weight of LT105 with options	kg	lbs
Side conveyor H 5-5	600	1320
Bracket for magn. separator	300	660
Magnetic separator	1100	2420
Feed hopper (9m ³)	570	1255
Hydr. setting adjustm.	100	220
Recycling plate	85	187
Long conveyor H10-15	1765	3890
Dust cover	140	310
Hammer & Pedestal	1500	3300

Notice: The units actual weight can be calculated by adding the weight of the options to unit base weight. (Note: Weights are directive. There can be some differences due to manufacturing tolerances.)

Chapter 7

Crushing

CRUSHING

7.1 CRUSHING LOCATION.....	7-1
7.2 FEEDING MEASURES.....	7-3
7.3 DISCHARGE ARRANGEMENT.....	7-4
7.4 CRUSHING.....	7-6
7.5 BY PASS CHUTE.....	7-11
7.6 FEED CONTROL.....	7-12
7.7 MINIMUM SETTING.....	7-13
7.8 CLEARING OF THE BLOCKAGE.....	7-14
7.9 REMOVAL OF THE STEEL.....	7-14
7.10 RECYCLING.....	7-15
7.11 OPTIONAL EQUIPMENT.....	7-15
7.12 INSTRUCTIONS FOR RADIO CONTROL (OPTIONAL).....	7-16

7.1 CRUSHING LOCATION

The LT105 should be located near the material pile to make loading easy and fast. Shape the feed material pile with the wheel loader or excavator so that it is in small area and high enough for easy loading (figure 7.1.1).

The location of the discharge pile must be chosen so that it doesn't cause any danger to workers or passers-by. Ensure that there is enough space for the discharge pile, discharge machinery (a wheel loader or excavator) and a lorry (figure 7.1.2).

The location where the crusher is to be placed must be even. The machine must not be allowed to sway. The surface below the crusher must be levelled and evened out. Spread some fine-grained material on the ground, distributing it evenly (figure 7.1.3). Next, harden the underlying ground by driving the LT105 back and forth over the site (figure 7.1.4).

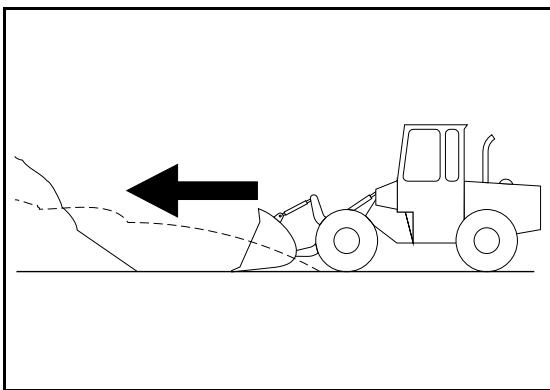

Figure 7.1.1 First shape the material pile

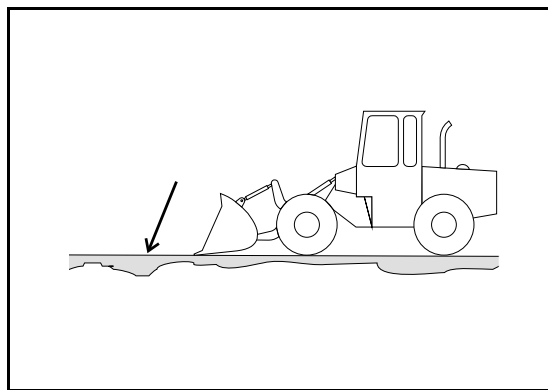

Figure 7.1.3 Spread some fine material on the ground, then rub it smooth.

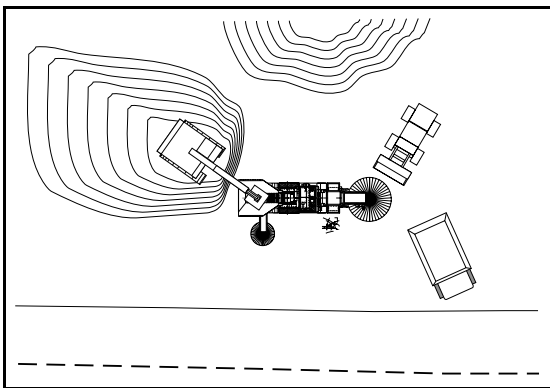

Figure 7.1.2 General measures taken on the site.

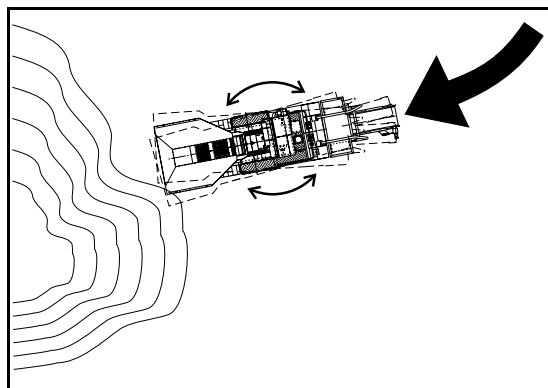

Figure 7.1.4 Strengthen the underlying ground by driving the LT105 back and forth over it.

While crushing, make sure the LT105 is in horizontal position. The maximum inclination allowance is 1 degree in lateral direction and 2 degrees longitudinal direction (figures 7.1.5 and 7.1.6).

For purposes of maintenance it is recommended that you dig a hole under the LT105 unit (figure 7.1.7).

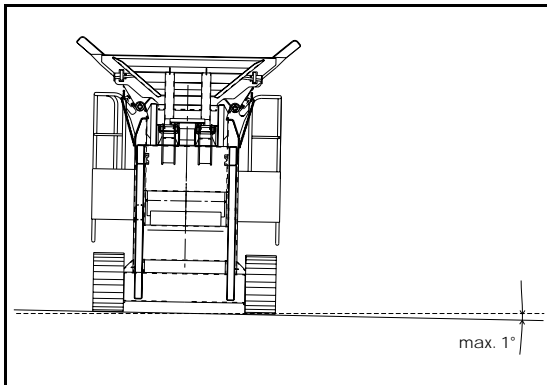

Figure 7.1.5 The maximum lateral inclination permitted during the crushing process is 1 degree.

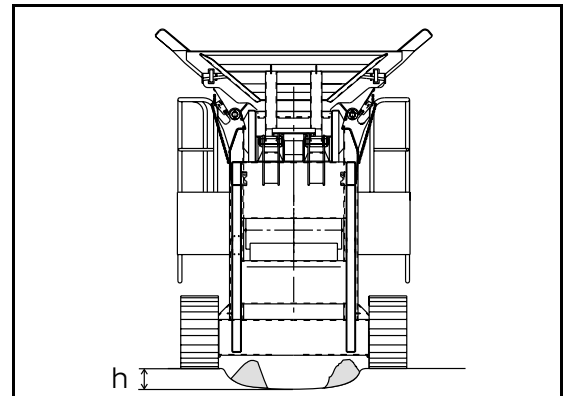

Figure 7.1.7 Dig a hole under the LT105 for purposes of maintenance.

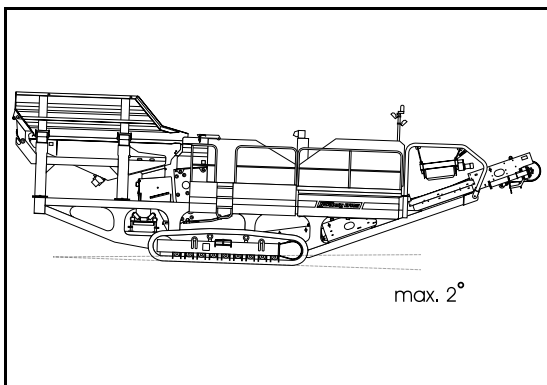

Figure 7.1.6 The maximum longitudinal inclination permitted during the crushing process is 2 degrees.

7.2 FEEDING MEASURES

LOADING EQUIPMENT

The LT105 can be loaded with the help of either an excavator or a wheel loader.

LOADING USING AN EXCAVATOR

The LT105 can be loaded from the side or the rear.

Find a suitable loading site and move the excavator bucket to its loading position. Then drive the LT105 into a suitable position below the excavator bucket.

The operator of the excavator must have full visibility to the upper part of the feeder (figure 7.2.1).

Load the material into the rear end of the feeder, on top of the solid base (figure 7.2.2).

If the feed material contains metals, someone should stand next to the feeder and remove the metal pieces before they are able to enter the crusher.

LOADING USING A WHEEL LOADER

The LT105 can only be loaded from the rear. Maximum bucket width is 3200 mm (126").

If required, use the feed material to make a loading ramp to ease access to the feeder.

Drive the LT105 as close to the pile as possible to make loading quick and easy.



NOTE: The feeder has two basic applications: stabilising the feed rate and separating the fine material before it enters the jaw crusher. If the feeder is too full, it will not separate the fine material, which in turn will result in decreased operating capacity.



NOTE: Do not hit the excavator bucket into the material or try to force the material into the jaw cavity.

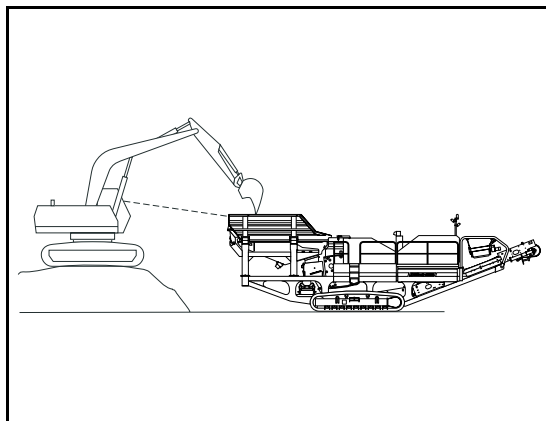

Figure 7.2.1 The operator of the excavator must have full visibility to the upper part of the feeder.

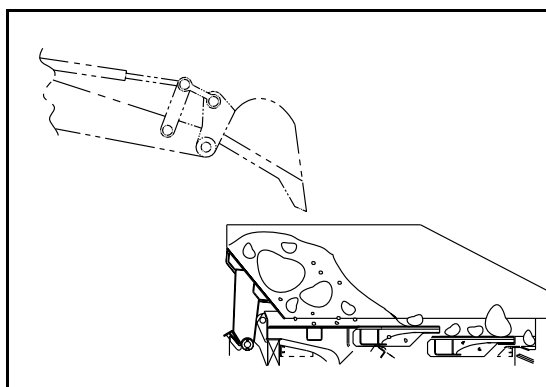

Figure 7.2.2 Load the material into the rear end of the feeder on top of the solid base.

7.3 DISCHARGE ARRANGEMENT

ALTERNATIVES

- Wheel loader
- Stack conveyor
- Additional process
- Lokotrack (secondary)

Check the height and volume of the discharge pile. Do not let the pile grow so high that it reaches the the conveyor. The distance between the pile and the conveyor must always be at least 200 mm (9") (figure 7.2.1).

When discharging with the help of the wheel loader, be careful not to damage the conveyor. Discharge from the side, do not push the material under the LT105 unit.

The material emitted from the vibrating chute can be directed to either the main conveyor or the side conveyor with the help of the control plate.

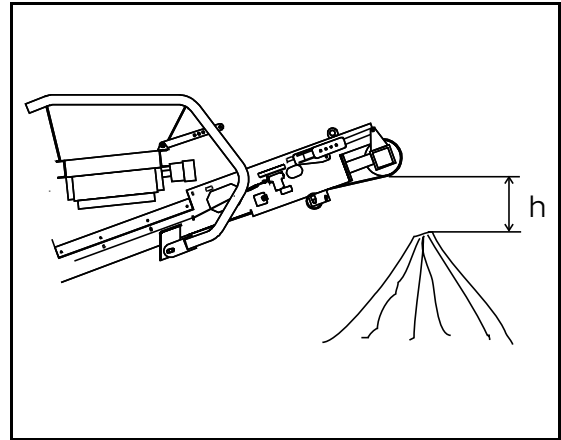

Figure 7.3.1 The distance (**h**) between the pile and the conveyor must always be at least 200 mm (9").

7.3.1 EXTENDED DISCHARGE CONVEYOR

FROM TRANSPORT TO CRUSHING

- Activate the manual valves (ref. 4.4)
- Release the transport lock. Lift the conveyor slightly to remove the locking pin.
- Turn the conveyor drivehead to crushing position (ref. 3.9)
- Fasten the locking pins in their places. The head of the pin must be inside the conveyor frame
- Reset the trip wire switches. Adjust their tightness as required.
- Secure the position of the side rubbers in both of the joints.
- Deactivate the manual valves.

FROM CRUSHING TO TRANSPORT

- Activate hand valves
- Turn the hydraulic output switch ON (ref. 4.1 and 12)
- Remove crushing position locking pins at from their places Lift the conveyor slightly to allow easy locking pin removal
- Lower the conveyor drivehead to transport position
- Mount transport lockings at their place
- Deactivate hand valves

NOTE: Observe great care when driving the LT105 onto the low bed due to the reduced ground clearance at the conveyor end.

NOTE: The discharge conveyor can only be folded on top of an even surface.

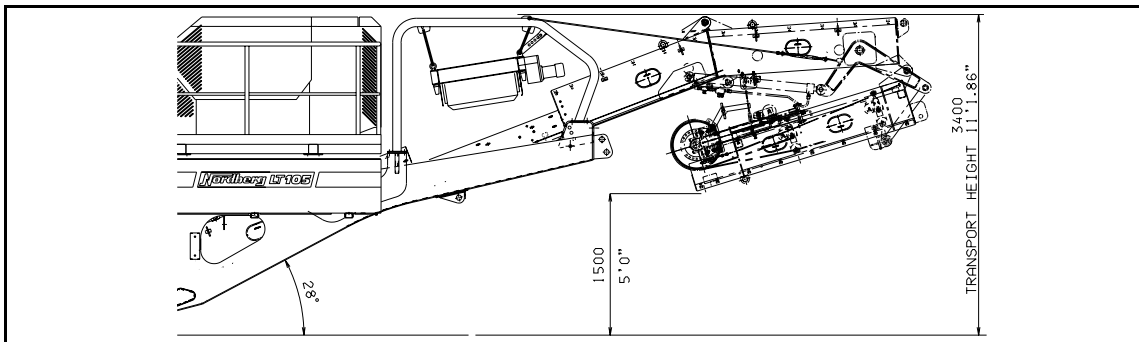

Figure 7.3.2 Transport position

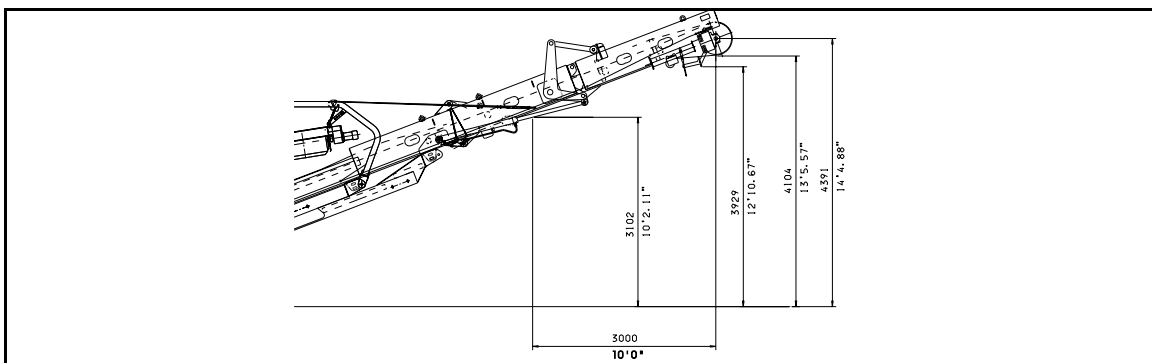

Figure 7.3.3 Crushing position

7.4 CRUSHING

Release the transport locks from the side conveyor (optional). Turn the side conveyor down with the help of the controls located in the hydraulic valve section (figures 7.4.1 and 7.4.2).

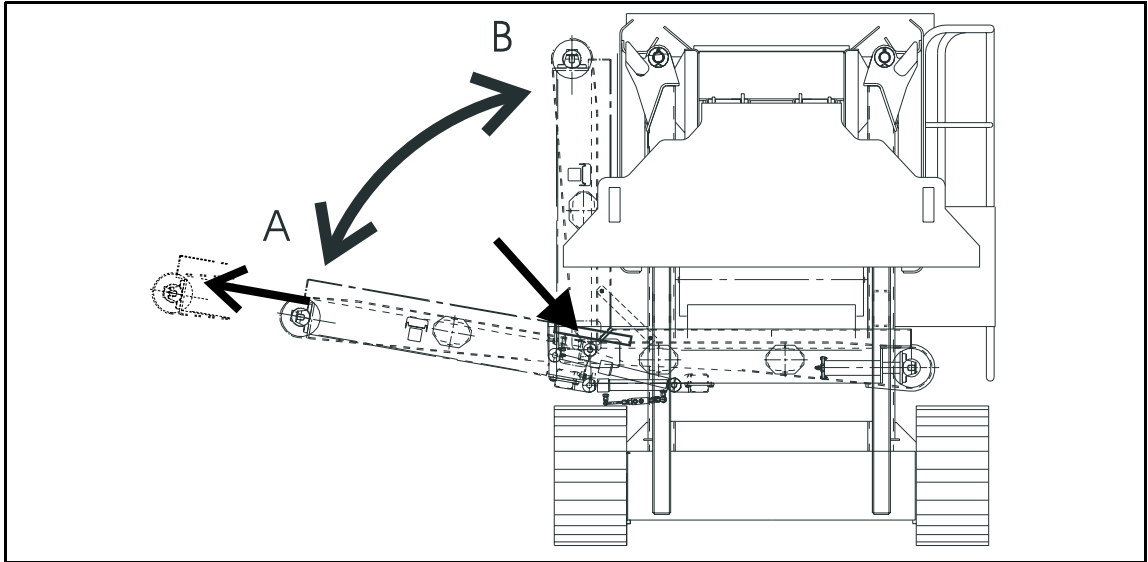

Figure 7.4.1 Turn the side conveyor down with the help of the control levers.

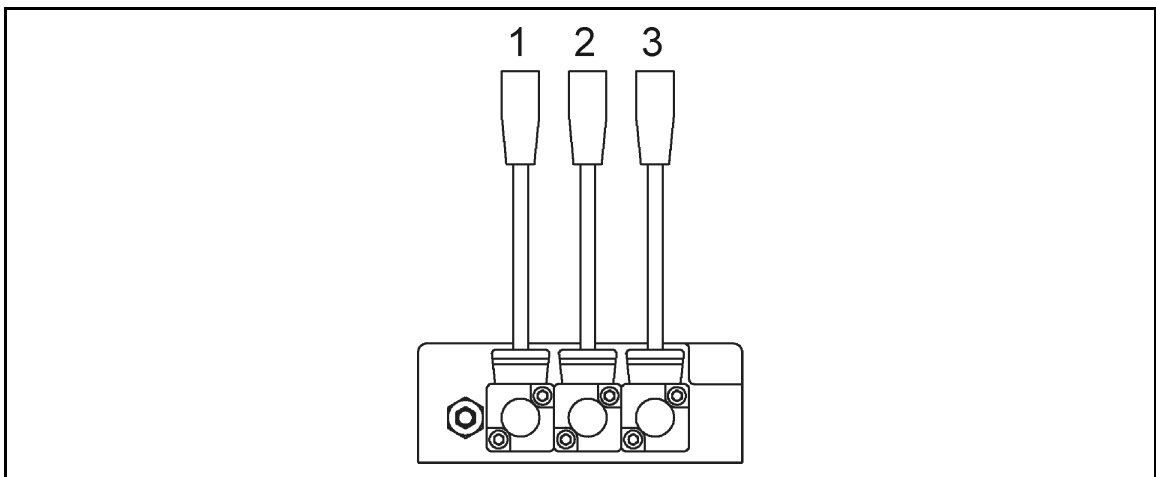

Figure 7.4.2 Conveyor control switches: 1) Side conveyor up/down, 2) Side conveyor in/out, 3) Main conveyor folding. NOTE: The control switch for manual valves, refer to Chapter 3.9.

Turn up the side walls of the feed hopper and lock them in place with the help of the wedges (figure 7.4.3).

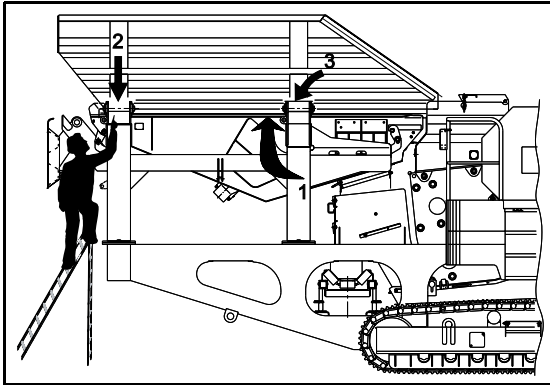

Figure 7.4.3 Turn up the side walls of the feed hopper. NOTE: Do not stand in side of the frame when mounting the wedge on it's place

If the additional side walls of the unit are not lifted with hydraulic cylinders, be extremely careful when lifting or lowering them. In this case, the side walls must be lifted and lowered using a crane. Make sure that there is no-one below the side walls, or too near them, as it may cause an accident risk.

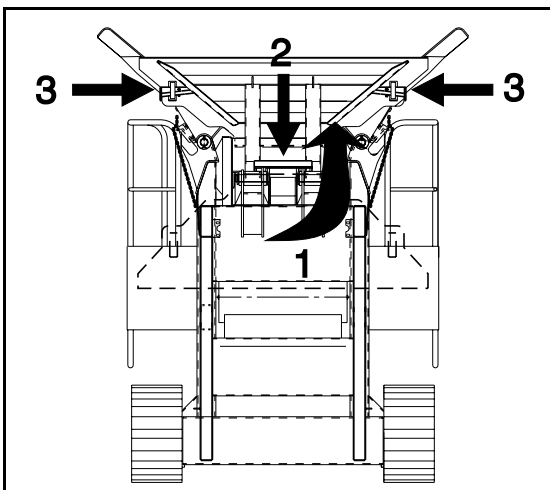

Figure 7.4.4 Turn the rear wall of the feed hopper upwards.

NOTE: A lifting instrument, such as a rope or chain, that is used to lift a single side wall, will not be strong enough to lift the entire LT105 unit. When the side wall is lifted vertically against the joint hinge, the mass of the entire LT105 may apply to the lifting instrument.

When lifting the side walls, first lift the side wall to its uppermost position with the crane (phase 1) and position the wedges. When positioning the wedges, the crane must not make any corrective measures. If the wedge cannot be fitted in its place, the mechanic must move away from the side wall and give new instructions to the crane attendant. After this, place the wedge first at the crusher end (phase 2) and then at the feeding end (phase 3). Once the wedges are fitted in their positions, make sure that they are tightly in their positions by hammering them. Finally, secure them with screws or chains.

Lifting or lowering the side walls must in no circumstances be done with the help of an excavator.

The order of lifting the walls: first, lift both side walls, then the back side wall. After lifting the back side wall, position and lock its wedge as well.

To lower the walls, perform the steps above in reverse order. Before removing the wedges, first set and tighten the lifting ropes of the crane. Do not perform any corrective measures during the operation.

NOTE: If the side walls are lifted with the help of a hydraulic cylinder, they are lifted in the same order as explained above. Lift and lock one side wall at a time, as explained above. When positioning the wedges, do not lift or lower anything.

Remove the transport locking of the feeder (figure 7.4.5).

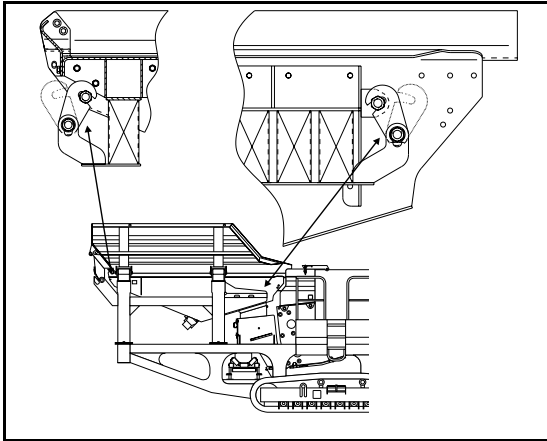

Figure 7.4.5 Remove the transport locking of the feeder.

Turn the light pole up (figure 7.4.6).

Make sure that the crusher is always operated in a safe manner and that it is in good mechanical condition. Make sure that the crusher is securely stationed so that there is no risk of its inclination.

Operation of the crusher is only permitted, when all necessary protective and safety devices, e.g. guards, emergency stop devices, silencers, aspirators etc. are in place and in full operating condition.

Before starting the crushing process, make sure that no-one is on, next to or under the crusher. Before starting the machine, caution everybody in its vicinity that you are about to start the crusher.

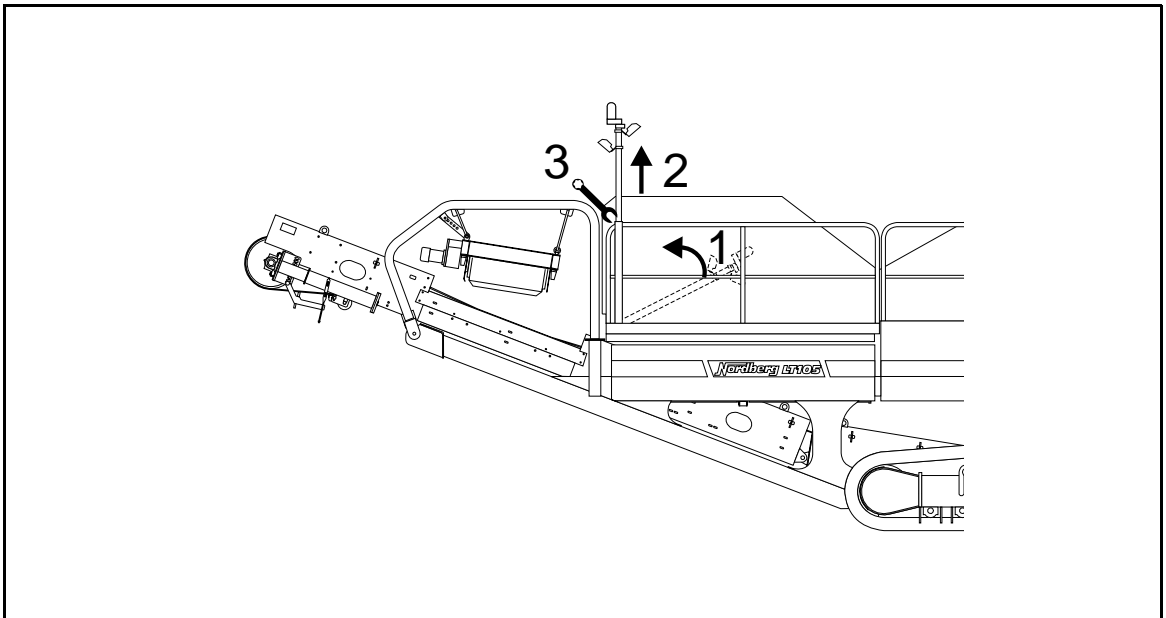

Figure 7.4.6 Turn the light pole up

Starting the crushing process

Before starting the crushing process, always make sure that the crusher cavity is empty. If there is material on the cavity, clear the cavity as instructed in chapter 7.8.

When the crushing process has started, the RPM speed of the diesel engine cannot be adjusted by the operator before the crushing process has been stopped again.

Initiate the crushing process by pressing "Process ON" -button (ref 4.1 and 4.2)

NOTE: When starting the crushing process, the automatic control function takes care of starting the devices, delays, monitoring any possible problems and adjusting the RPM level of the diesel engine. The initiation of the crushing process takes about one minute after the process button has been pressed.

- Connect the water supply (if needed).
- Turn on the lights if required.

Stop the crushing process by pressing the "Process OFF" -button.

NOTE: When stopping the crushing process, the automatic control function takes care of turning off the equipment, delays, monitoring any possible problems and adjusting the RPM level of the diesel engine. The termination of the crushing process takes approximately 1 minute.

1. Process options eg. side conveyor, magnet separator or hydraulic PTO must be selected before the process start. Process options are editable during the process.

2. You can stop the feeder and crusher in order to safely remove uncrushable objects from the feeder. Crusher and feeder can be restarted from the service platform.

Load some material into the feed hopper while the vibrating chute is running. For further instructions, refer to Chapter 7.6 "Feed control".

When loading with the help of a wheel loader, the feed hopper must be almost empty before any moer material can be loaded into it. When loading with the help of an excavator, more than one bucketful can be loaded in to the hopper at a time.

Refer to the Crusher Instruction Manual for further information on the crushing process.

In case of emergency press "Emergency stop"-button to stop the LT105.

Do not attempt to crush stones that are too large to fit inside the cavity. Having to reposition rocks wastes time, reduces capacity, and imposes unnecessary loads on the crusher.

You can stop the feeder and crusher in order to safely remove uncrushable objects from the feeder. Both the crusher and the feeder can be restarted from the remote control box located in the service platform.

NOTE: Clay, wood and any non-stone-based materials must be prevented from entering the crusher. This may overload and damage the crusher. Also make sure that no explosives are allowed to enter the crusher.

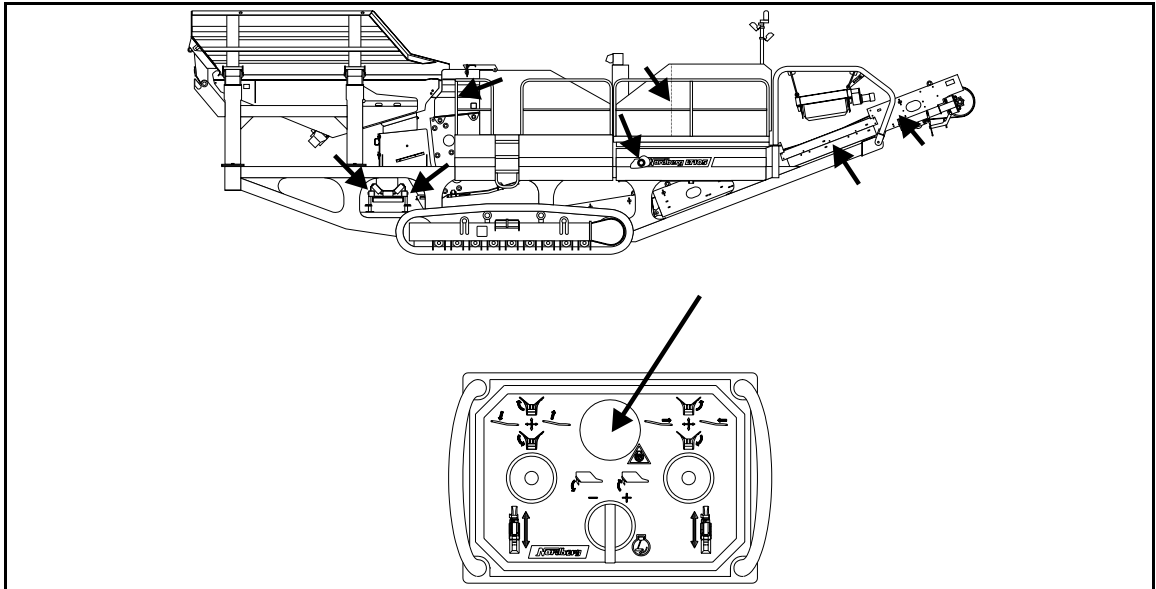

Figure 7.4.7 "Emergency stop" - buttons (for more information, refer to 5.5)

NOTE: The side conveyor must not be switched on if it is in transport position

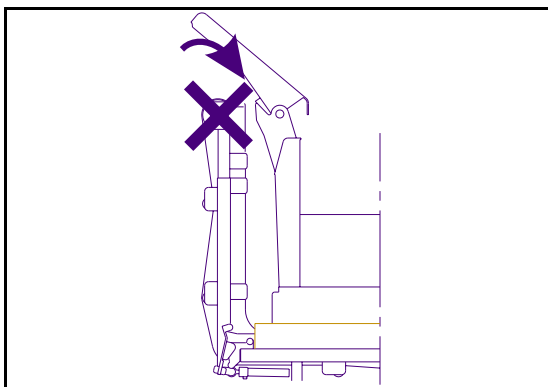

Figure 7.4.8 Do not switch the side conveyor on while it is in a transport position.

7.5 BY PASS CHUTE

Location of the by-pass chute hatch.

The material flow that passes below the feeder grizzlies can be directed towards the main conveyor (fig.7.5.1) or towards the optional side conveyor (fig.7.5.2). With the optional screen deck, materials larger than the mesh can be directed towards the main conveyor. (fig.7.5.3). Turn the lever to change the direction of the material flow. When using the centre position, lock the lever in place using a bolt.

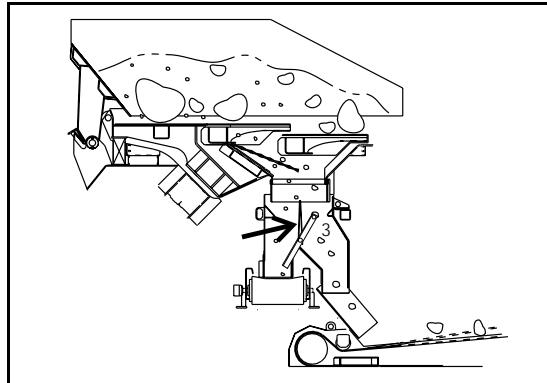

Figure 7.5.3 The flow of materials has been screened and directed either to the side conveyor (pass-through) or to the main conveyor.

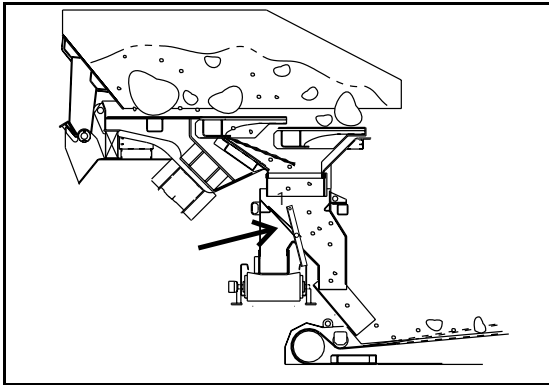

Figure 7.5.1 The chute has been directed towards the main conveyor.

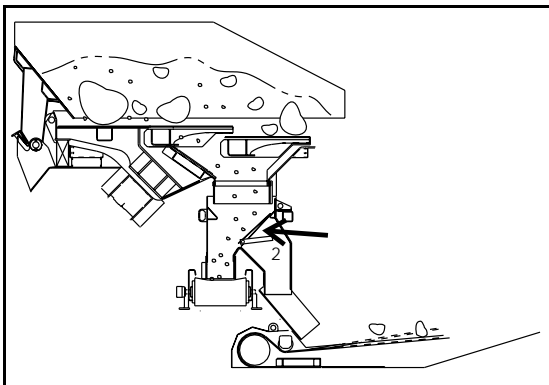

Figure 7.5.2 The chute has been directed towards the side conveyor.

7.6 FEED CONTROL

The feeder can be stopped and restarted again during the crushing process. The “feeder start” and “stop” buttons are located in the remote control box on the service platform. If the machine is equipped with a radio control feature (optional), the feeder can be started and stopped using the radio control feature.

To stop and restart the feeder do the following:

1. Stop the feeder during the crushing process by pressing the "feeder stop" button.
2. Restart the feeder after it has stopped completely by pressing the "feeder start" button.

NOTE: The feeder starts automatically when the process is started and stops when the process is stopped. If the hydraulic temperature of the unit is extremely cold (10°C/14°F), the system will ask to carry out a cold start of the process. The feeder will not start until the temperature of the oil has reached a certain temperature.

In order to stabilise the feed rate, the feeder always starts at minimum speed regardless of the speed setting. After a while the speed changes to the set value.

In order to control the capacity, the feeder speed can be adjusted using the crusher speed +/-switch. The switch is located in the control box on the service platform.

NOTE: When the process is running, the automatic control takes care of stopping of restarting the feeder. The feeder will stop if the speed of the crusher decreases or the level indicator (optional) of the crusher indicates an alarm.

NOTE: If the feeder speed is too high, stones may fall over the flanks of the hopper.

NOTE: Radio control will by-pass the feeder controls located in the control box on the service platform.



The best capacity can be reached by having the feeder remain running for as long as possible.

7.7 MINIMUM SETTING

The hardness of the feed material will effect the minimum setting. Refer to the C-Jaw instruction manual for the setting ranges.

7.7.1 FEED MATERIAL

Feed sizes depending on the material in question:

Concrete 0...550 mm (22").

Concrete with rebars 0...550 mm(22"), the maximum length of the rebars 500 mm(20") and max. diameter is 20 mm(3/4").

Construction rubble (mixed, including fines) 0...550 mm(22").

Bricks 0...550 mm(22").

Rock 0...550 mm(22").

Asphalt 0...550 mm(22") (only if the temperature is below +10° C(50° F) and the bitumen content is low).

Slag 0...550 mm(22").

The size of the material is measured as illustrated in figure 7.7.1.

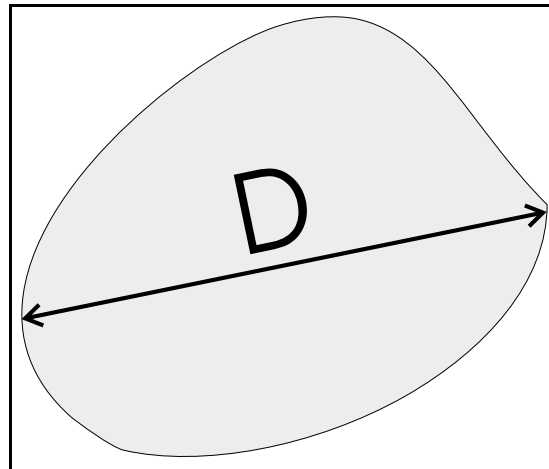

Figure 7.7.1 Measurement of the material dimensions.

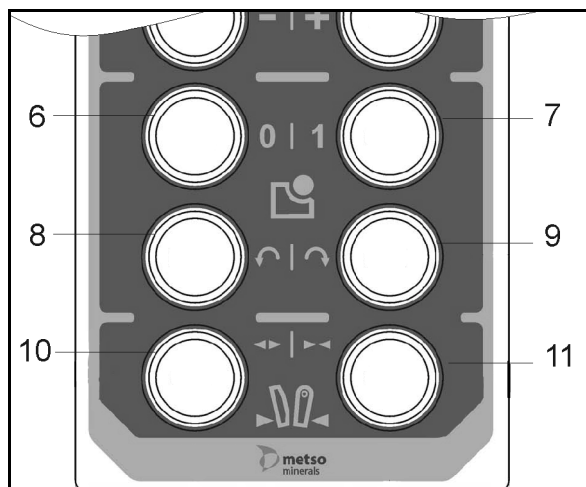

Figure 7.7.2 Setting adjustment

7.7.2 SETTING ADJUSTMENT

Manual setting adjustment: refer to the C-Jaw Instruction Manual for instructions on setting adjustment.

Hydraulic setting adjustment:

Settings can be adjusted only when the crusher is in the maintenance/adjustment mode.

- 10: opens the setting
- 11: closes the setting.
- 6: crusher stop-button: crusher in maintenance/adjustment mode.

The process does not have to be stopped completely when changing settings.

Process is restarted with the crusher start button (7) and the feeder start button (3), see chp. 4.3.

7.8 CLEARING OF THE BLOCKAGE

NOTE: Never try to clear the blockage with an excavator.

If the process is initiated with material in the cavity, the crusher tries to start with slow ramp and if the rock is strong enough to prevent crusher from starting, the alarm # 3 (“Crusher pressure rising too fast on start”) will be shown in the display.

The process will be fully activated but the feeder and the crusher will not function. You can swing the crusher clockwise and counter clockwise with the buttons 8 and 9 (fig. 7.8.1) of the remote control box, located on the service platform.

When the cavity is clear, switch on the crusher using the “Crusher start” -button (# 7, figure 7.8.1).

Start the feeder.

7.9 REMOVAL OF THE STEEL

Always stop the machine (feeder, crusher, conveyors and engine) before removing metal from it. Make sure that it can not be started during removing metal from it.

Use a hook to remove iron bars and wires. Be very careful not to hurt yourself. **Never use a hook when the machine is running.**

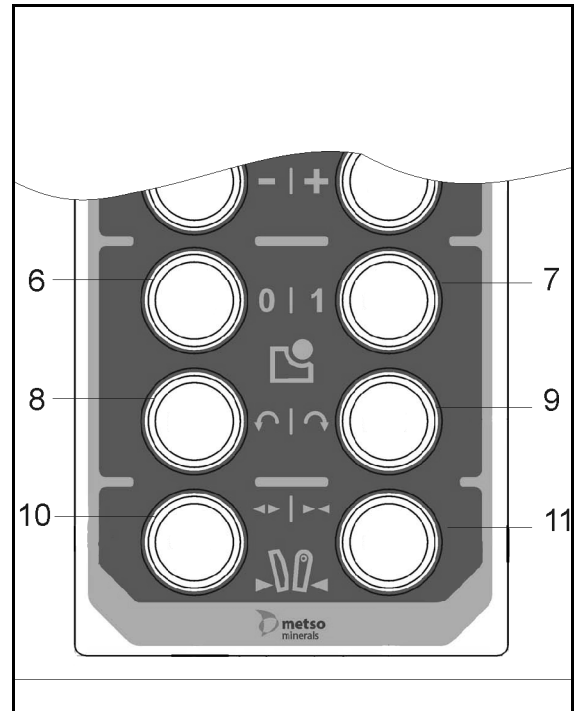

Figure 7.8.1 Remote control

7.10 RECYCLING

In carrying out recycling processes with the crusher, all metal objects should be removed from the feed before they enter the crusher.

Someone should stand next to the feeder and remove the metal pieces. Be very careful when touching the feed material. The feeder must be stopped when removing larger objects. Never climb on top of the feeder.

The most efficient method is to prepare the feed material for the process and remove all the metal pieces from it before loading it to the LT105.

The optional magnetic separator can be used for the removal of small metal objects. The maximum diameter allowance for steel objects entering the crusher is 20 mm. The maximum length allowance is 0,5m.

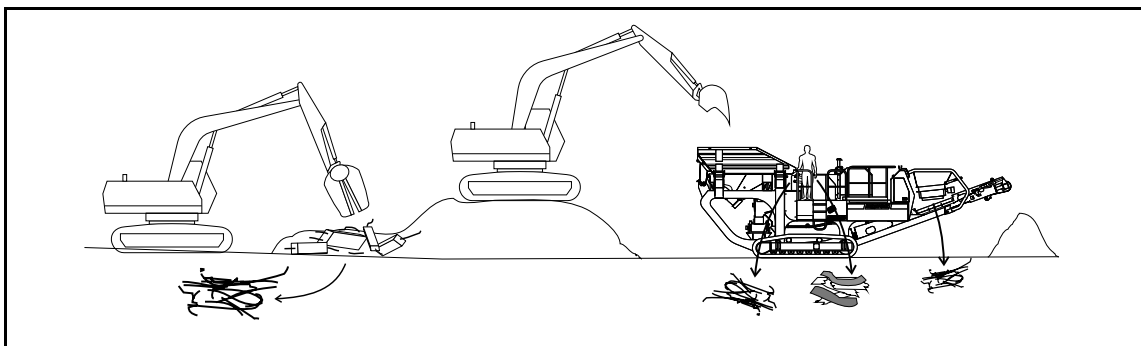

Figure 7.10.1 Removal of metal objects during the crushing of recyclable materials.

7.11 OPTIONAL EQUIPMENT

LEVEL INDICATOR

The purpose of the level indicator is to control the feed material level that enters the crusher. The indicator stops the feed process and emits a light signal when the material level is too high. The indicator resets itself automatically.

Keep the level indicator clean to ensure that it functions properly.

Refer to the IC500 Instruction Manual for further information on switching the level indicator to ON or OFF position.

HYDRAULIC OUTPUT

The hydraulic output can be set ON/OFF permanently or ON with the process. Refer to the IC500 Instruction Manual for further information on how to select the hydraulic output.

INTERMEDIATE CABLE FOR SECONDARY UNIT

The LT105 unit is equipped with a 6-pin socket allowing information flow between the primary and the secondary unit. The socket has three different functions:

Pins 1&2: When connected, LT105 gets information on the connection of the secondary unit.

Pins 3&4: Feeder ON/OFF information (secondary feed/emergency functions can be connected to this). Normally open contact required.

Pins 5&6: For the level sensor of the secondary unit. Normally closed contact required.

7.12 INSTRUCTIONS FOR RADIO CONTROL (OPTIONAL)

7.12.1 RADIO COMPONENTS

Transmitter, receiver, two batteries, charging device for the batteries, two key-switches, power outlet adapter for 24VDC.

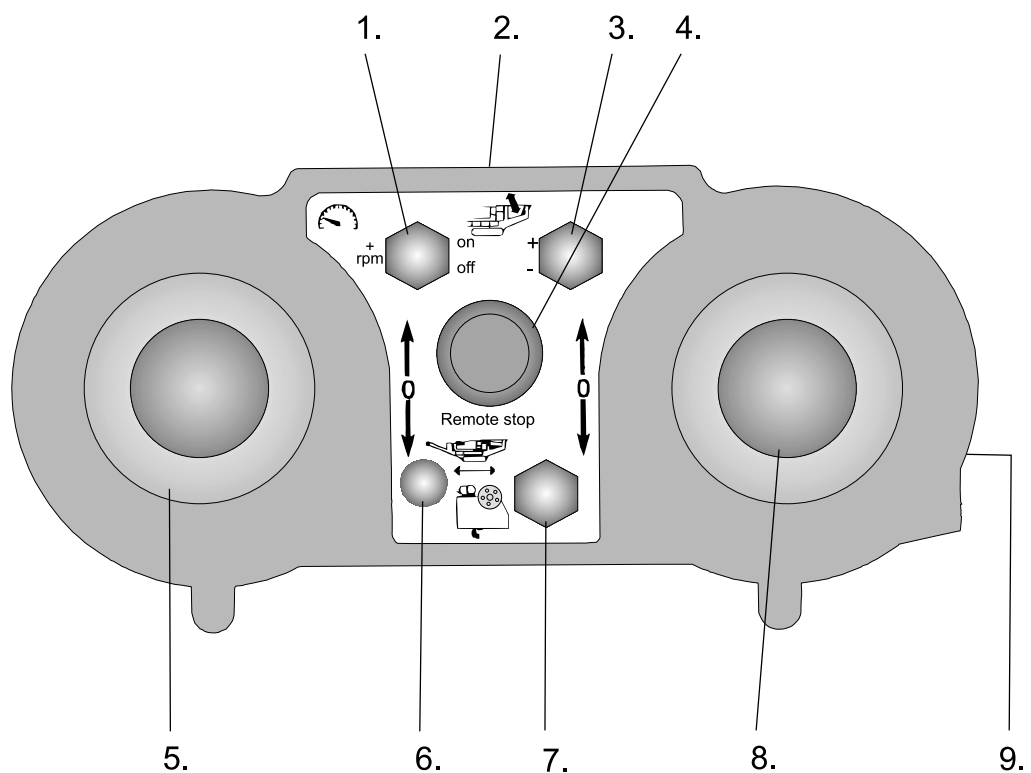

- | | |
|---------------------------------------|--------------------------------------|
| 1. Engine rpm UP-DOWN / feeder ON-OFF | 6. Battery voltage level indicator |
| 2. Battery | 7. Selector switch tracking-crushing |
| 3. Feeder speed increase/decrease | 8. Right track forward-backward |
| 4. Remote STOP | 9. Key-switch |
| 5. Left track forward/backward | |

7.12.2 SELECTING THE RADIO CONTROL FUNCTION

The control panel has a selector switch, Radio control ON/OFF (refer to Chapter 4. Radio control, switch 8.). In ON position, the radio control mode is activated. Note: the feeder can only be controlled with the help of the radio control device when the radio control mode has been selected.

7.12.3 STARTING THE RADIO REMOTE CONTROL FUNCTION

The radio transmitter can be switched on by turning the key switch located on the right side of the radio (the key can be removed in the 0 position.)

Turn the key switch to position 1. The radio transmitter will indicate the turning of the key switch by emitting two peeps. By turning the key switch to START position after the acoustic signals have been emitted, the radio can be activated.

NOTE! The radio transmitter is equipped with an automatic battery saving function and the radio transmitter will be automatically switched off if the the radio functions have not been used for 10 minutes. The radio must be switched on again if radio control is required.

7.12.4 BATTERY VOLTAGE LEVEL

1. Voltage level indicator

LED indicator 6 indicates the voltage level by flashing. When the voltage level decreases, the flashing becomes less frequent.

The radio will not function if the voltage level decreases too much.

Try to utilise the full capacity of the batteries in order to increase the battery lifetime.

2. Voltage level alarm

The transmitter emits an acoustic signal when the transmitter battery capacity is nearly exhausted.

7.12.5 USING THE RADIO CONTROL FEATURE

Select the track driving mode or crushing mode with switch # 7.

Tracking Mode:

- Switch 1: Engine RPM level up/down

- Levers 5 & 8: Track controls
- Switch 3 does not have a function in tracking mode.

Crushing Mode:

- Switch 1: Feeder ON/OFF
- Switch 3: Feeder speed adjustment
- Levers 5 & 8 do not have any functions in the crushing mode. (LT105/LT80)

Remote-controlled STOP Function

The unit can be quickly stopped with the help of the remote-controlled stop function.

NOTE! The remote-controlled stop function requires that the radio transmitter be activated. Use of the remote-controlled stop function is not possible if the radio has not been activated or if the battery capacity of the radio transmitter has been exhausted.

Chapter 8

Screen unit

SCREEN UNIT

8.1 MAIN ASSEMBLY	8-1
8.2 CONNECTION PARTS OF THE SCREEN UNIT	8-2
8.3 HYDRAULIC VALVE MODULE	8-4
8.4 CONTROL PANEL FOR SCREEN UNIT.....	8-5
8.5 MANUAL CONTROLS WITH SCREEN UNIT	8-6
8.6 FOLDING THE SCREEN UNIT TO CRUSHING POSITION.....	8-6
8.7 PROCESSING WITH THE SCREEN UNIT.....	8-9
8.8 TRACKING ON SITE WITH LT05S	8-9
8.9 FOLDING THE SCREEN UNIT TO TRANSPORT POSITION	8-11
8.10 DISCONNECTING THE SCREEN UNIT FROM THE LT105	8-13
8.11 CONNECTING SCREEN UNIT TO LT105S	8-16
8.12 PERIODICAL MAINTENANCE	8-16

8.1 MAIN ASSEMBLY

Weight: 4360 kg / 9590 lbs
 Width (transport position): 2800 mm
 Length (transport position): 5600 mm

Screen unit is powered with hydraulic power of the LT105S. Control system of the LT105S unit will recognize the screen unit automatically when the electrical socket is connected. Crushing process of the LT105S starts with the screen if the socket and hydraulic hoses are connected.

WARNING! MAKE SURE THAT ALL HYDRAULIC CONNECTIONS ARE PROPERLY CONNECTED BEFORE STARTING THE DIESEL ENGINE

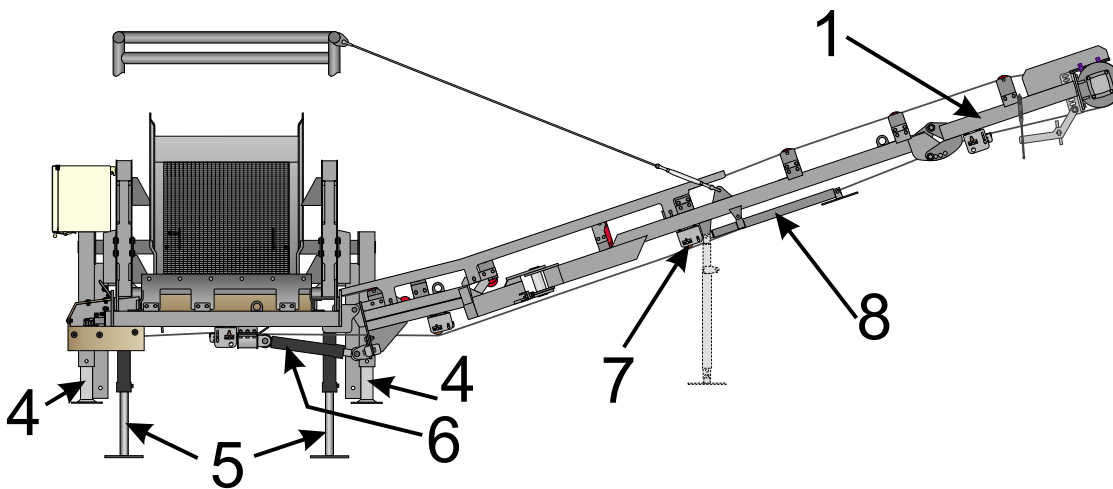
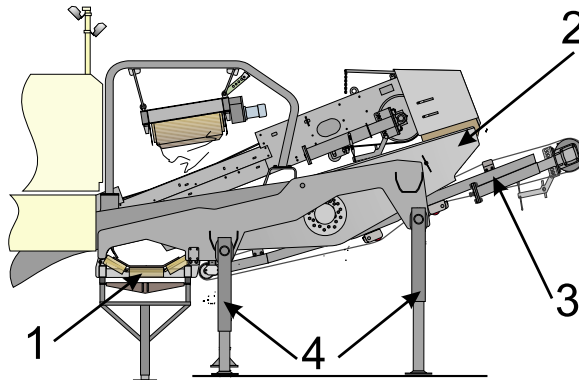

- | | |
|------------------------------|---|
| 1. H8-8 oversized conveyor | 5. Hydraulic legs |
| 2. Screen TK11 - 30S | 6. Cylinder for H8-8 up / down movement |
| 3. H6,5-4 undersize conveyor | 7. Cylinder for H8-8 sideways movement |
| 4. Mechanical legs | 8. Mechanical support leg for the H8-8 conveyor |

8.2 CONNECTION PARTS OF THE SCREEN UNIT

Electrical connections:

1. Connection socket for screen module: 24 DC power (refer to fig. 8.1.1, #3)
2. Connection socket for screen module control panel (located on the hydraulic module of the screen unit, refer to fig. 8.3.1).

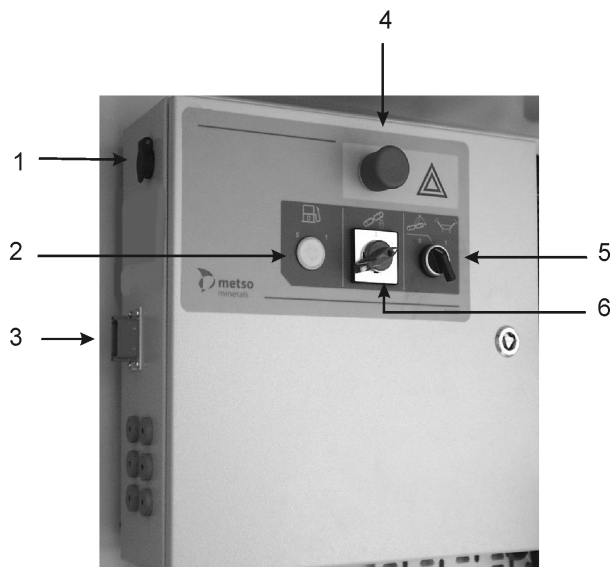
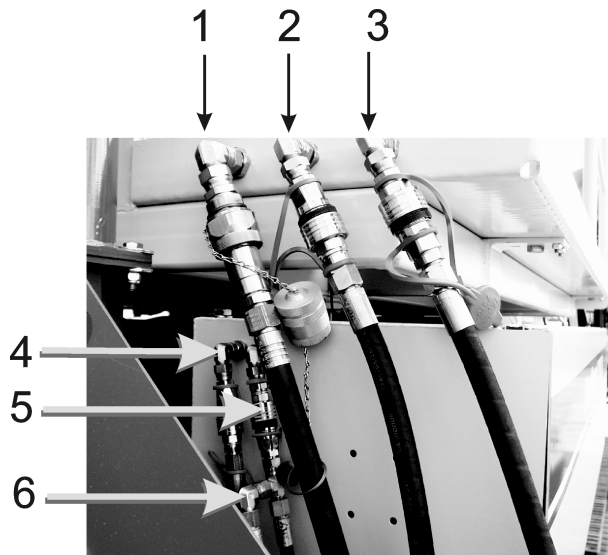

Figure 8.1.1 Hydraulic control module (HCM) panel

1. Connection socket for the service light
2. Fuel pump (optional)
3. Connection socket for screen module
4. Emergency button
5. Switch for hand valves
6. Safety switch for conveyors

Hydraulic connections:



1. Pressure line to valve block
2. Return line from valve block
3. Return line of H8-8 conveyor
4. Load sense line from valve block
5. Screen drive motor leakage
6. Line conveyor leakage

NOTE: Connect or disconnect the quick connectors only when the diesel engine is shut off.

Mechanical connection:

Screen unit is mounted with 4 pins to the Lokotrack frame. Pins are secured with lock rings.

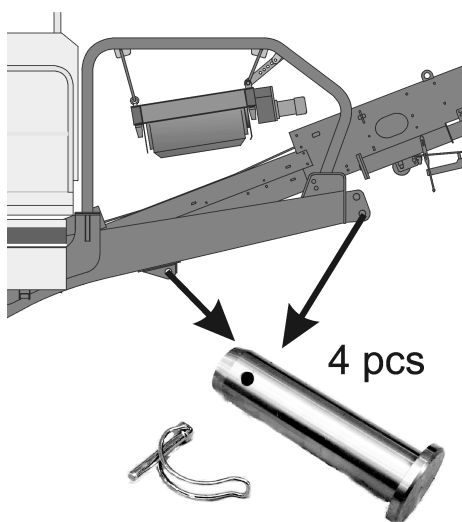

8.3 HYDRAULIC VALVE MODULE

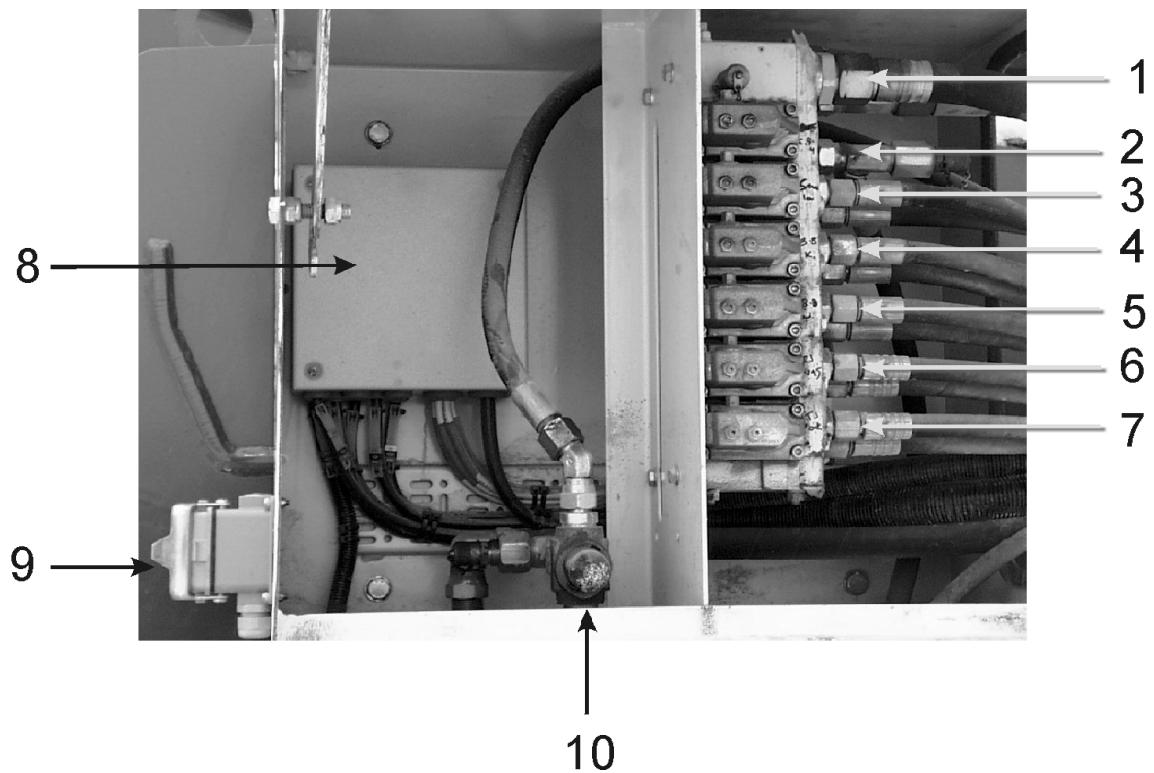
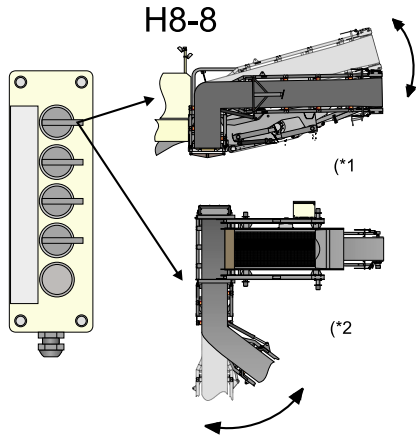

Figure 8.1.1 Hydraulic valve module

1. Pressure relief & connection section
2. H6,5 - 4 and H8-8 conveyor drive valves
3. Screen drive valve
4. H8-8 conveyor swing left / right
5. H8-8 conveyor swing up / down
6. Left hydraulic support leg
7. Right hydraulic support leg
8. Junction box 24 VDC
9. Connection socket for screen module control panel
10. Pressure relief valve

8.4 CONTROL PANEL FOR SCREEN UNIT

- a. H8-8 conveyor swing up / right



- b. H8-8 conveyor swing left / down

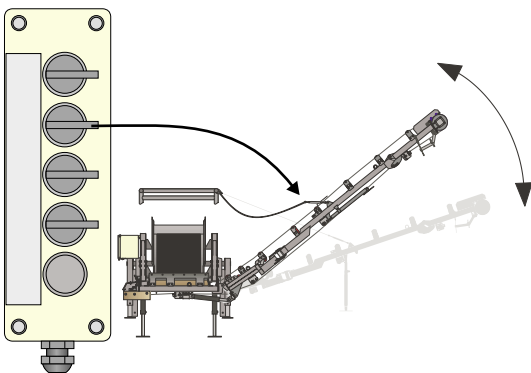

- c. Hydraulic support leg up / down (at hydraulic module side)
d. Hydraulic support leg up / down (at conveyor side)

Control panel socket is located on the hydraulic valve module.

NOTE: Make sure that all hydraulic connections are properly connected before using. Control panel for screen unit.

8.5 MANUAL CONTROLS WITH SCREEN UNIT

The screen and screen unit conveyors can be forced manually ON/OFF from the process options/manual control menu (refer to the IC500 Instruction Manual).

8.6 FOLDING THE SCREEN UNIT TO CRUSHING POSITION

1. Connect the screen module control panel for folding to the control socket (LT105 control panel)
2. Release transport lockings
3. Lift the drive end of the H8-8 conveyor slightly upwards in order to allow the conveyor to swing above the support.

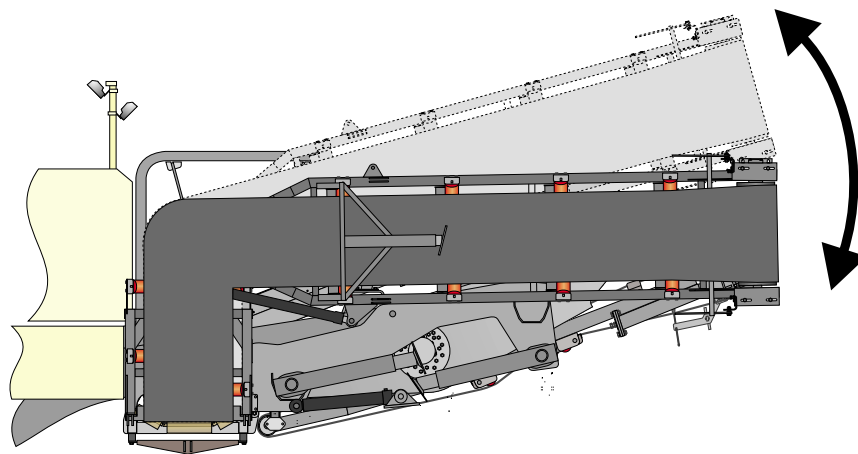

4. Swing the H8-8 conveyor 30° downwards from the vertical position.

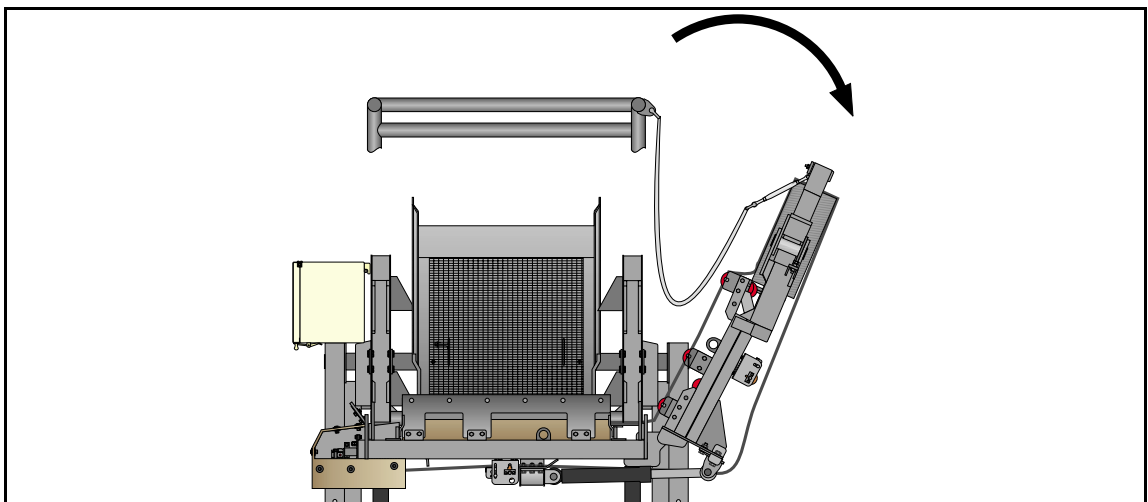

5. Straighten the conveyor H8-8

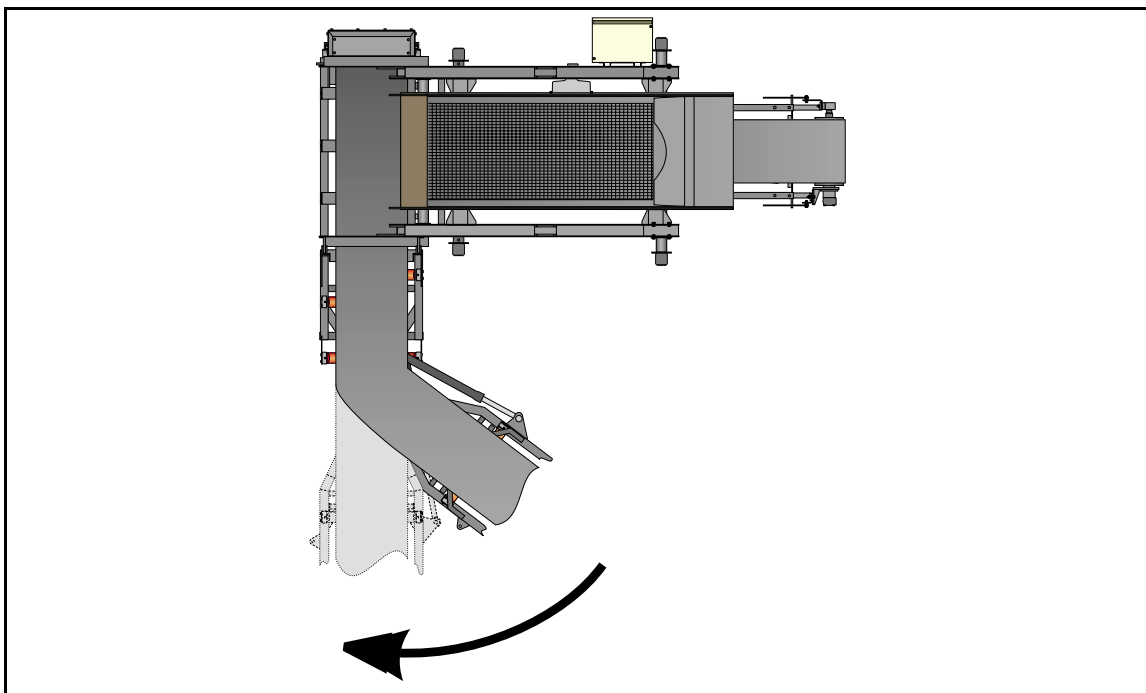

6. Release the support leg and lower the conveyor H8-8 above the support.
7. Release the hydraulic support legs and support screen module against the ground.

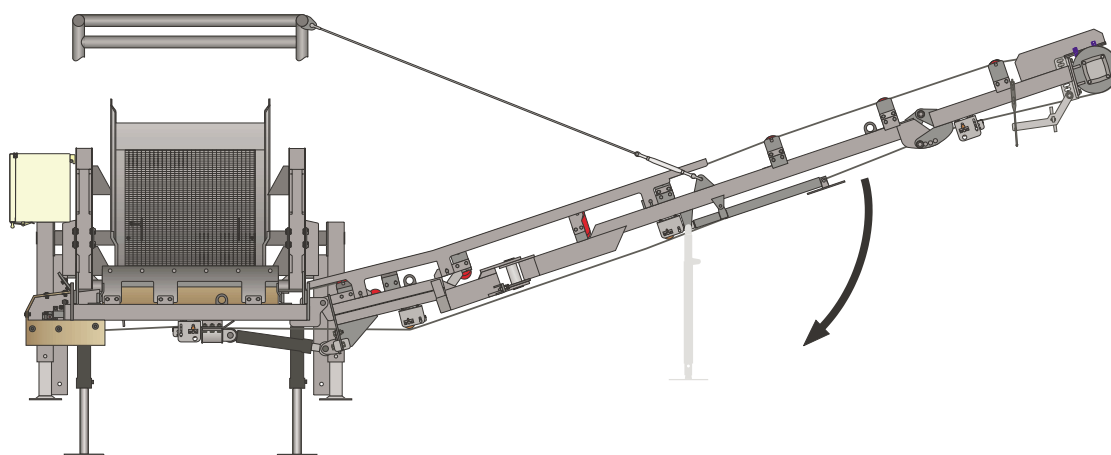

8. Lift conveyor H8-8 side walls on their place and lock the conveyor joint with the locking pin.

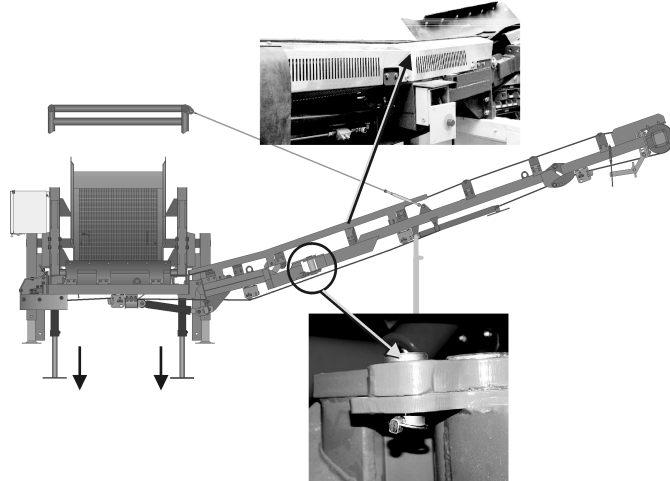

9. Remove the screen transport locking.
10. Remove the conveyor belt rubber strap.
11. Start the crushing process and observe belt tracking and support leg balance.

8.7 PROCESSING WITH THE SCREEN UNIT

NOTE: Screen unit must be in crushing position before process is started.

Conveyors and screen will start automatically during the process start.

For the emergency stop, both conveyors are equipped with trip wire switches. If a trip wire switch is activated, the feeder of LT105 will stop immediately and the material in the main conveyor is collected to the screen.

Screening efficiency is higher when the rotation direction of the screen is against the material flow direction. Due to reduced material flow it might reduce the tonnage of the unit. Standard rotation direction is along the material flow, this will give highest tonnage. The direction of the screen unit can be selected from the process options window (Refer to the IC500 Instruction Manual).

Maximum feed to the screen unit is 200 mm / 8 ".

Minimum mesh hole size # 10 mm. Maximum mesh hole size 50 mm.

8.8 TRACKING ON SITE WITH LT05S

WARNING! MAKE SURE THAT ALL HYDRAULIC CONNECTIONS ARE PROPERLY CONNECTED BEFORE STARTING. THE DIESEL ENGINE PROCESS. KEEP THE CONTROL PANEL OF THE SCREEN DISCONNECTED WHILE PROCESSING.

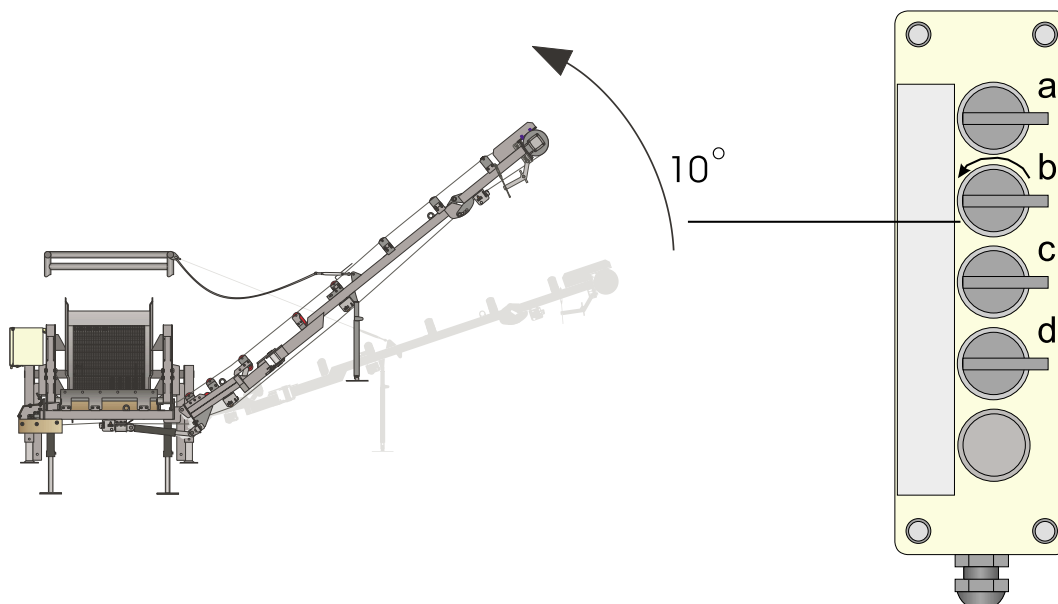

1. Raise the H8-8 conveyor 10° by using the control panel.

2. Turn the support leg of H8 - 8 conveyor to rest position and secure with a locking pin.

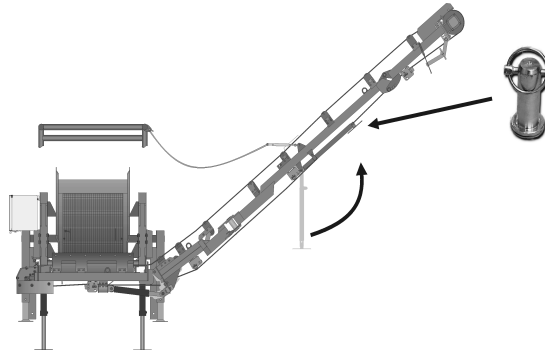

3. Lower the H8 - 8 conveyor until the weight rests on the steel cables.

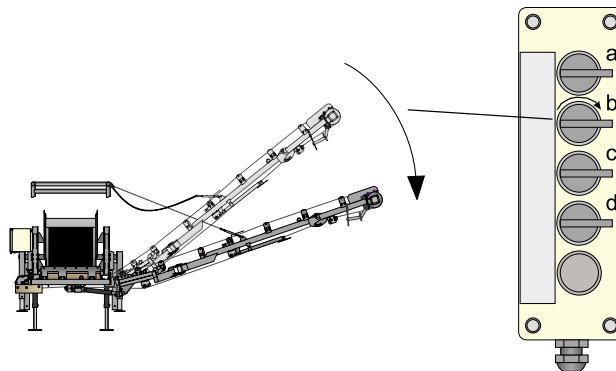

4. Raise the hydraulic support legs.

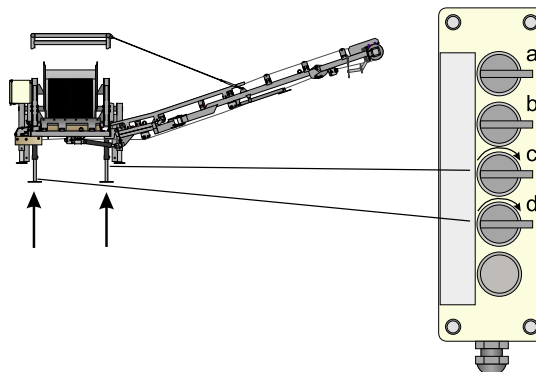

5. Unit is ready to be moved on site.

8.9 FOLDING THE SCREEN UNIT TO TRANSPORT POSITION

1. Remove the side walls of the H8Ä8 conveyor from their place.
2. Remove the locking pin of the H8-8 conveyor from it's position. (Swing prevention)
3. Assemble the rubber strap to the conveyor H8-8 to prevent conveyor belt from sliding out it's place.
4. Lift the conveyor

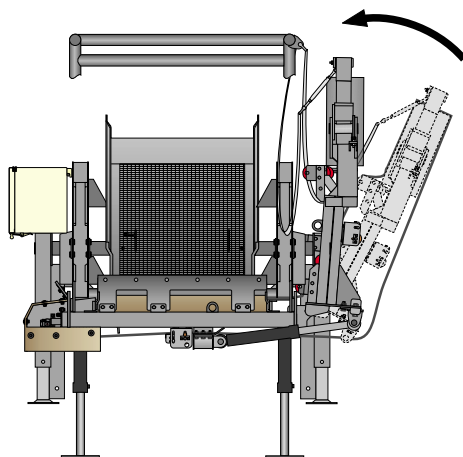

5. Raise the support leg of the H8-8 conveyor and lock to rest position

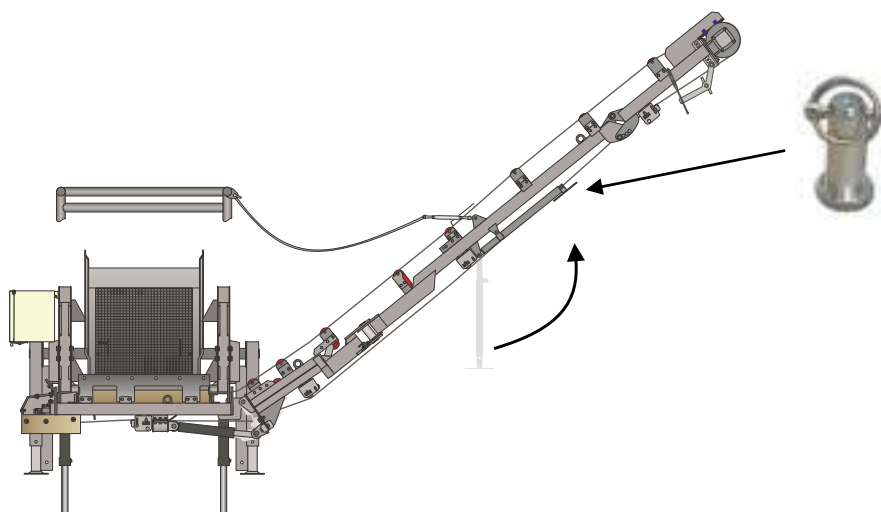

6. Raise the support leg of the H8-8 conveyor and lock to rest position

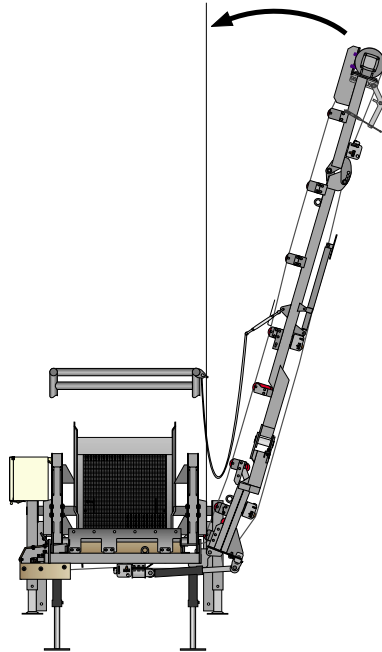

7. Swing the conveyor downwards above the support

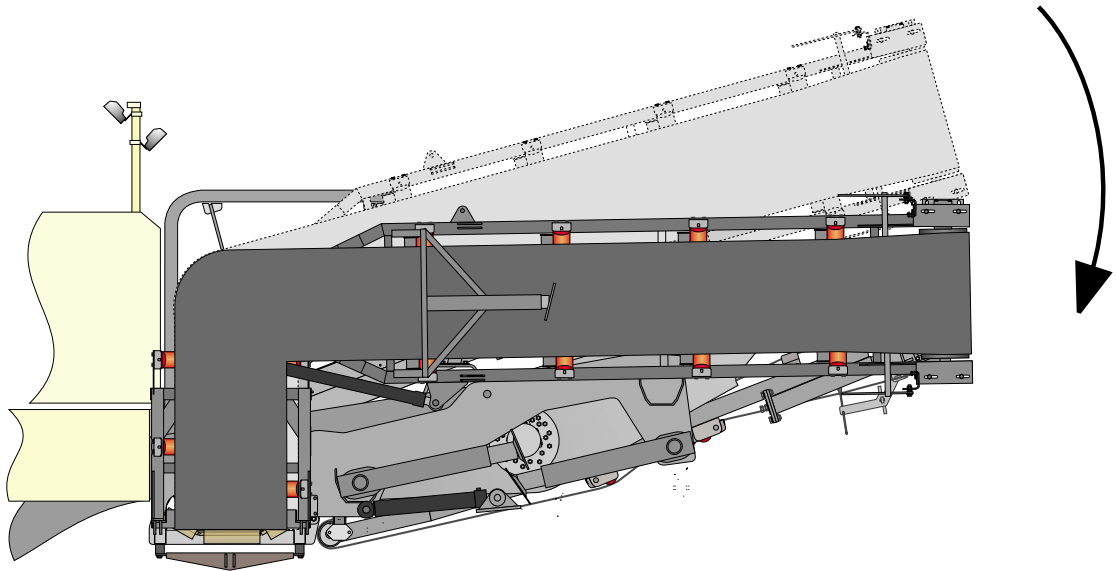

8. Raise the conveyor to the vertical position and secure with transport locking.

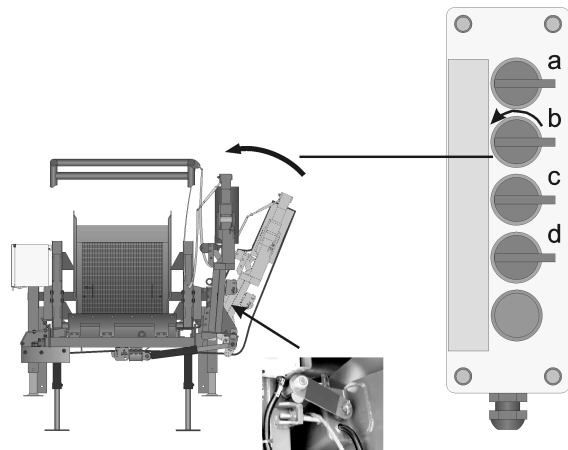

9. Raise hydraulic legs to upright position and raise them to transport position.

8.10 DISCONNECTING THE SCREEN UNIT FROM THE LT105

NOTE: Find a plain surface to disconnect the screen unit

1. Fold the screen unit to crushing position
2. Release the mechanical support legs (a) and mount the support arms with locking pins (c) to their places. Furthest legs must be pulled (b) out to middle position, before locking them to vertical position.

a)

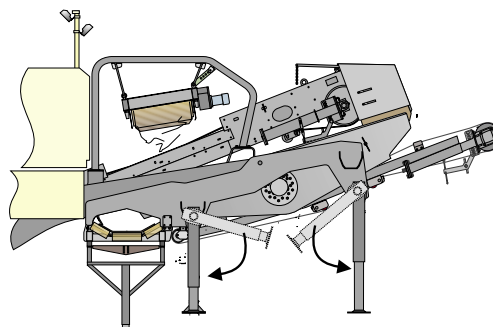

b)



c)



3. Extend the hydraulic legs as far out as they come.

- When the hydraulic legs are fully extended, lower the furthest mechanical support legs down and lock them to next position from the ground (50mm ground clearance required)

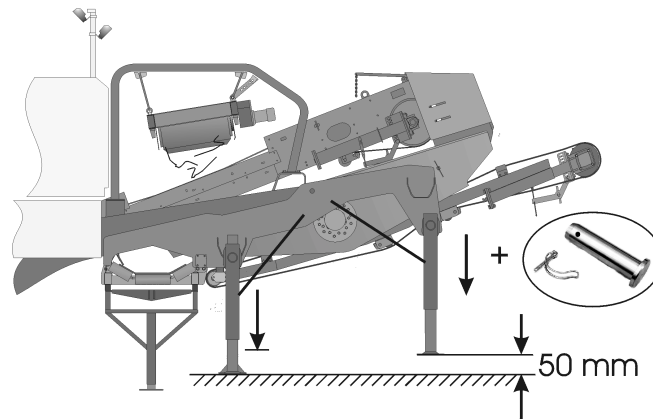

- Retract the hydraulic support legs so that both of the furthest mechanical support legs are properly supported to the ground. The frame of the screen unit is now no clearance free against the LT105S frame and the upper pin & locking ring pair can be removed from their place.

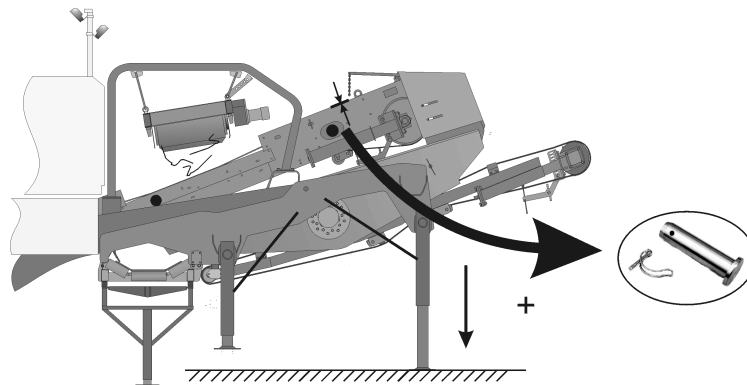

- Extend the hydraulic cylinders fully. Lower the nearest mechanical support legs down and lock them to next position from the ground.
- Retract the hydraulic cylinders so that the weight of the screen module is on the mechanical legs.

8. Remove the second pair of pins & locking rings.

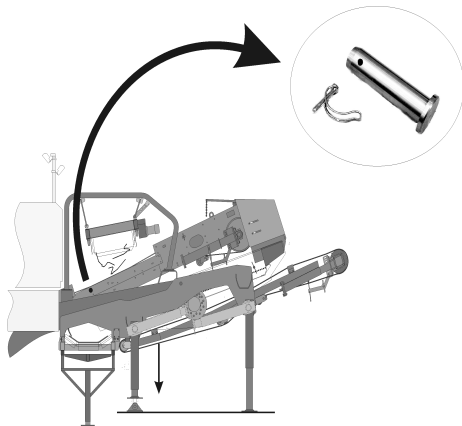

NOTE: Stop the engine in order to disconnect the hydraulic hoses between the screen unit and LT105S

9. Disconnect the electrical plug and socket arrangement between the screen unit and LT105S
10. Disconnect the steel cables between LT105S frame and H8-8 conveyor
11. Drive the LT105S directly away from the screen unit. Use crawling speed and observe that the unit moves directly and does not damage to the frame of screen unit.

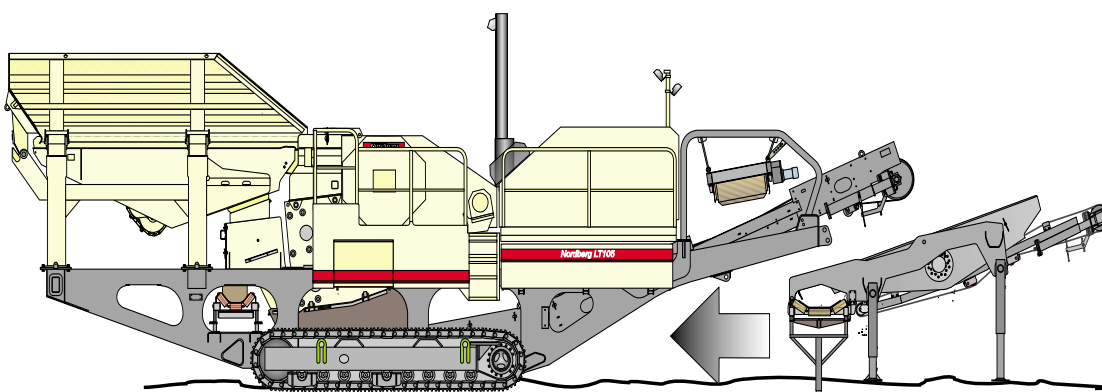

8.11 CONNECTING SCREEN UNIT TO LT105S

1. Drive LT105S directly to the screen unit.
2. Connect hydraulic hoses.
3. Connect electrical cable of the screen unit to the LT105S.
4. Connect steel cables between LT105S frame and H8-8 conveyor.
5. Insert locking pins to their places. (Use hydraulic support legs for fine tuning the hole alignment).
6. Extend hydraulic support legs fully out.
7. Remove support arms of the mechanical support legs and store them properly.
8. Lift mechanical support legs to upright position

NOTE: Connect or disconnect the quick connectors only when the diesel engine is shut off.

8.12 PERIODICAL MAINTENANCE

Maintenance intervals:

ITEM	daily	weekly	every month	6 months
H8 - 8 CONVEYOR				
Belt tracking & tension	x			
Greasing: 10 g / 40 h / each bearing		x		
Check roller condition		x		
Greasing folding joints			x	
H6,5 - 4 CONVEYOR				
Belt tracking & tension	x			
Greasing: 5 g / 40 h / each bearing		x		
Check roller condition		x		
TK11 - 30S SCREEN				
Greasing: 10 g / 40 h / each bearing	x			
Mesh condition & cleanliness	x			
Listen the sound of screen	x			
Check support springs		x		
Check wear parts		x		
Check the bolt torques				x
Check the bearing temperature & sound				x

Lubricant: Suitable grease quality is a multi-purpose grease with a NLGI-class of 2 and a good resistance to water, cold (-30 / - 22 F) and hot (continuous operating temperature + 100°C / 212°F). The grease must not oxidize easily and it must contain EP-additives. Don't use grease containing molybdenum. The minimum viscosity of the base oil must be 160 mm²/s (cSt) in 40°C / 104°F and minimum viscosity index 80.

Please consult TK11-30S instruction manual for more detailed information.

Chapter 9

Maintenance

MAINTENANCE

9.1 PERIODICAL MAINTENANCE	9-1
9.2 RUNNING-IN	9-4
9.3 HYDRAULICS	9-4
9.4 FINAL DRIVE	9-5
9.5 FUEL LEVEL	9-5
9.6 CRUSHER SPACER REMOVAL & ASSEMBLY / TOGGLE PLATE CHANGE	9-5
9.7 FILLING VOLUMES	9-6
9.8 TRACKS	9-7
9.9 LUBRICANT RECOMMENDATION	9-8
9.10 CRUSHER	9-8
9.11 FEEDER / SCREEN	9-8
9.12 TRACK GEAR	9-8
9.13 GREASE	9-8
9.14 ADDING HYDRAULIC FLUID	9-8
9.15 ADDING ENGINE FLUIDS	9-9
9.16 REMOVING ENGINE/HYDRAULIC FLUID	9-9
9.17 ENGINE FUEL FILTER REPLACEMENT	9-9

9.1 PERIODICAL MAINTENANCE

NOTE: Grease lubrication specification NLGI EP 2.

Carry out periodical maintenance according to given operating hours rather than given period.

	Daily	Weekly	Monthly/200 h	Every 6 months	Every 12 months	When needed
DIESEL ENGINE						
Change engine oil every 200 operating hours.			X			
Change oil filter every 200 operating hours.			X			
Drain water from fuel.		X				
Change the primary fuel filter every 200 operating hours.			X			
Change fine fuel filter every 200 operating hours.			X			
Check the service indicator of the air filter. Change the cartridge if necessary. Change the safety cartridge every third time.	X					
See the engine operating manual for other maintenance.						X
JAW CRUSHER						
Check V-belt tension.	X					
Check the tightness of the jaw bolts daily during the first 40 operating hours after jaw installation. Then weekly.	X	X				
Check the tightness of cheek plate bolts.	X					
Check the side guide plates and the protection rubber of the toggle plate.	X					
Lubricate crusher drive jack shaft 10g/40h/bearing		X				
Check wear on the jaw plates.	X					
Check the sound, temperature (max. 75°C/ 167°F) and grease flow in the eccentric bearings.	X					
Lubricate eccentric shaft bearings.		X				
Check wear on the cheek plates.		X				
Check toggle plate for alignment, straightness and cracks.		X				
Check toggle seats, clean as necessary.		X				
Check the tightness of the mounting bolts of the labyrinth covers and the frame bearings.		X				
Check the tightness of the frame tie rods.		X				
Check the mounting of the flywheel.			X			

	Daily	Weekly	Monthly/200 h	Every 6 months	Every 12 months	When needed
Check the tightness of the frame mounting bolts on the side plates.				X		
Check the bearings on the eccentric shaft.				X		
Check for any wear on the contact surfaces of the pitman and front frame.				X		
Check rubber damper condition of the jaw crusher			X			
Mounting of the crusher no horizontal movement. Check the locking mechanism.		X				
Check for any wear on the contact surfaces between the side plates and cheek plates.				X		
MECHANICAL SETTING ADJUSTMENT						
Lubricate the cap nuts of the setting adjustment device.		X				
Check the rubber covers.		X				
AUTOMATIC LUBRICATING DEVICE						
Check operation and grease amount (add grease if necessary).		X				
VIBRATOR UNIT						
Oil change (1000h) Ref: 8.7			X*	X		
Check oil level			X			
Replace breather 1000 h				X		
FEEDER						
Clean vibration unit from outside.		X				
Check tightness of vibration unit joints.				X		
Check the wires/hoses.			X			
Check tightness of screen deck mounting bolts		X				
CONVEYORS						
Lubricate the bearings of head and tail pulleys. 5g/40h/per bearing		X				
Check the belt tension.	X					
HYDRAULICS						
Check the oil level.	X					
Check the oil temperature (max 90°C / 194°F).	X					
Check the fixing bolts of all components.		X				
Check pipes and hoses.		X				
Change hydraulic oil every 2000 operating hours.				X		

	Daily	Weekly	Monthly/200 h	Every 6 months	Every 12 months	When needed
Clean the hydraulic tank every 2000 operating hours.				X		
Check the breather of the hydraulic tank. Replace every 6 months.		X		X		
FINAL DRIVE						
Check oil level.			X			
Change oil				X		
BATTERY						
Check fluid level.		X				
Check the cleanliness of the battery terminals.		X				
TRACKS						
Check tension of track chains.		X				
Check tightness of track bolts.		X				
MAGNETIC SEPARATOR						
Lubricate the bearings. 3g/40h/Bear.		X				
Check the belt tension.			X			
FUEL TANK						
Breather replacement				X		
Fuel fill pump filter replacement (optional)				X		

* First oil change

9.2 RUNNING-IN

See the Crusher Instruction Manual for further details.

9.3 HYDRAULICS

Basic requirements for the hydraulic oil quality:

- viscosity index should be min. 150
- min. viscosity 16 cSt at operating temperature
- max. viscosity 1000 cSt at starting temperature

Unless otherwise mentioned, the **factory fill oil** is a special hydraulic oil of ISO VG 46 class. The max. allowable operating temperature with this oil type is about +80°C (176°F) and min. allowable starting temperature is about -20°C (-4°F), which makes it **suitable for use all year round** in most operating conditions.

Attached some examples of oil brands meeting these requirements:

- BP Energol SHF 46
- Esso Univis N 46
- Shell Tellus Oil T 46
- Teboil Tebo Hydraulic Oil 46
- Mobil DTE 15

In winter time e.g. in cold climate conditions, when the operating temperature of the oil stays below +60°C (140°F), the use of a special hydraulic oil of ISO VG 32 class is recommended. The max. allowable operating temperature with this oil type is about +65°C (149°F) and min. allowable starting temperature is about -30°C (86°F).

Attached some examples of oil brands meeting these requirements:

- BP Energol SHF 32
- Esso Univis N 32
- Mobil DTE 13
- Shell Tellus Oil T 32
- Teboil Tebo Hydraulic Oil 32 S



In summer time e.g. in hot climate conditions, when the ambient temperature exceeds +35°C (95°F), the use of a special hydraulic oil of ISO VG 68 class is recommended. The max. allowable operating temperature with this oil type is about +90°C (194°F) and min. allowable starting temperature is about -10°C (14°F).

Attached some examples of oil brands meeting these requirements:

- BP Energol SHF 68
- Mobil DTE 16
- Teboil Tebo Hydraulic Oil 68



Oil amount is 520 litres (140 gal) .

9.3.1 HYDRAULIC ADJUSTMENTS

All components are set to operate at optimal speed. If adjustments is needed it is allowed only for Metso Minerals authorized persons.

Factory set speeds:

Crusher	320-325 rpm
Main conveyor	1,7-2,0 m/s (5,6-6.6 f/s)
Side conveyor	2,4-2,6 m/s (7,7-8,5 f/s)
Magnet conveyor	1,5-1,7 m/s (4,9-5,6 f/s)
Engine speed	2080 rpm (max 2100 rpm)
Feeder speed	500-1150 rpm
Screen unit Screen	1050-1100 rpm
Oversize conveyor	1,6-1,8 m/s (5.3-5,9 f/s)
Undersize conveyor	2,0-2,2 m/s (6,6-7,3 f/s)

9.4 FINAL DRIVE

Change final drive oil after first 150 operating hours. After that every 1500 operating hours. Oil amount is 4.5l (1.2 gal). Oil quality is ISO VG 220.

9.6 CRUSHER SPACER REMOVAL & ASSEMBLY / TOGGLE PLATE CHANGE

Please, refer to the C105 manual.

9.5 FUEL LEVEL

The fuel level can be checked from the fuel amount indicator in the display (figure 9.5.1). Fuel tank capacity 600l (160gal).

NOTE: The system will inform about a low fuel amount by a display alarm, but it will not prevent the machine from running out of fuel.

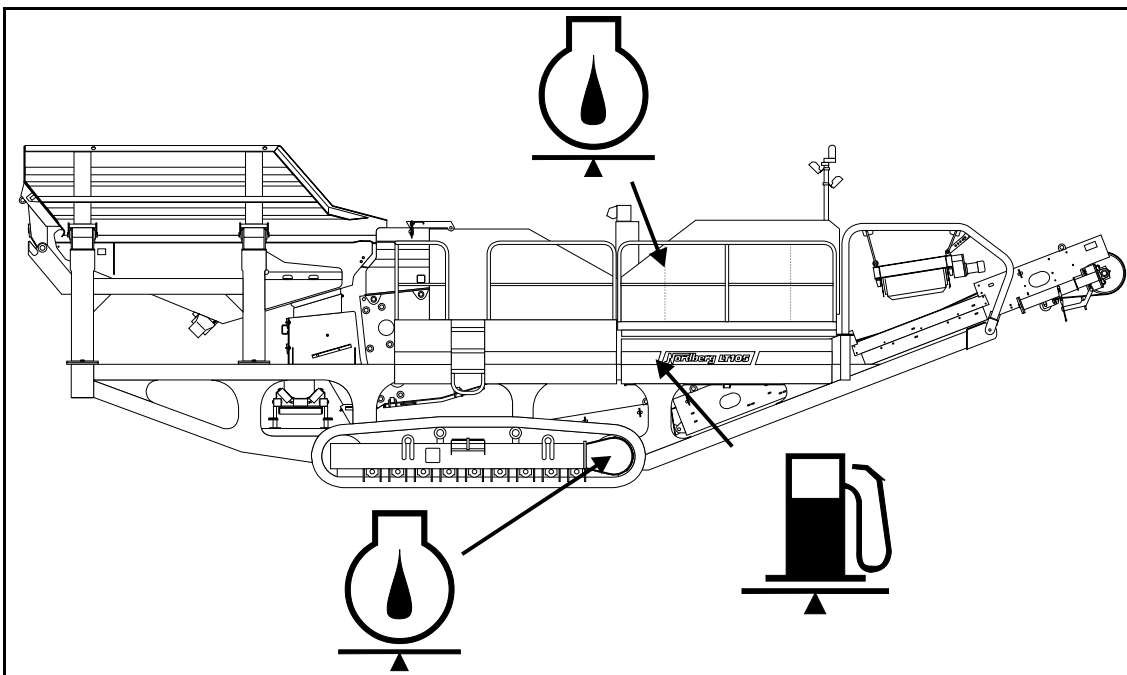

Figure 9.5.1 Checking the fuel level

9.7 FILLING VOLUMES

LT105		
	AMOUNT	TYPE
Hydraulics	520 l / 140 gal	ISO VG 46
Final drive	4,5 l / 1,2 gal	ISO VG 220
Fuel tank	600 l / 160 gal	
Feeder vibr. unit	4 l / 1 gal	ISO VG 150

CATERPILLAR C9	
Engine oil	28 l / 7,5 gal
Water	36 l / 9,5 gal

9.7.1 Engine Oil type

Allowed oil grades are: 10W30 and 15W40 (refer to the C-9 Operation and Maintenance Manual).

OIL GRADE PLUG

Engine is equipped with oil grade plug. (refer to the C-9 Operation and Maintenance Manual).

Factory filled oil type: 10W30 (plug position 1).

OIL GRADE DETECTION	
Plug	Oil Grade
1	10W30
2	15W40

9.8 TRACKS

Tension

- Check that the track chains are properly tensioned (figure 9.8.1). Adjust as necessary. See the correct chain deflection in the drawing 8.8.1. Measure in the middle of main pulley and idler. To tension tracks pump more grease into regulating cylinder with a grease gun. Correspondingly, the tracks are loosened by letting grease flow out through the opened grease nipple and moving the Lokotrack if needed.
- Check track shoes for damage.

Frame

Check the welded structure for cracks or weld failures, and carry out any necessary repairs as soon as possible.

Track shoe bolt torque

- With lubricant: 304-358 Nm / 224-264 ft/Lb
- Without lubricant: 365-430 Nm / 269-317 ft/Lb

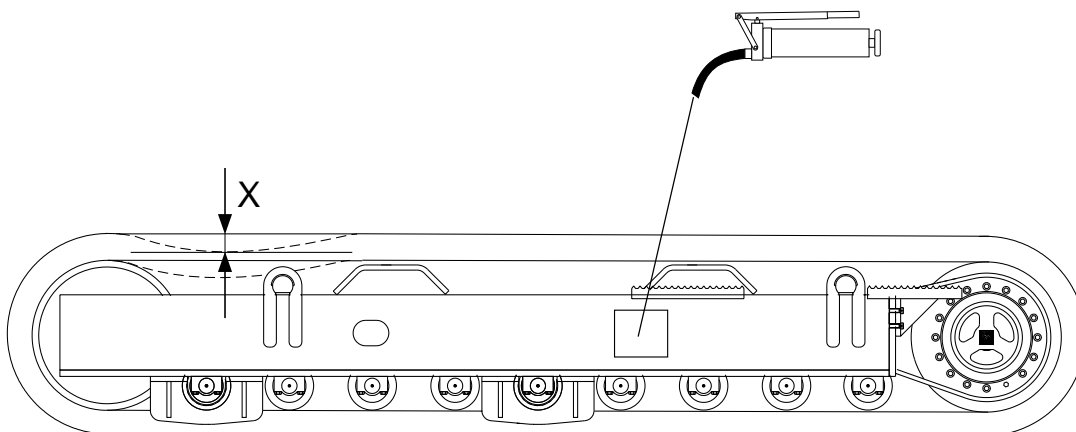

Figure 9.8.1 Check that the track chains are properly tensioned. The correct deflection (X) is 25 mm (1")

9.9 LUBRICANT RECOMMENDATION

This section contains information and instructions on several alternative and optional equipment. Normally Lokotracks have only some of them. Before maintaining and servicing, find out which alternative and optional equipment your Lokotrack has.

9.10 CRUSHER

See further instruction in your crusher manual.

9.11 FEEDER / SCREEN

See further instruction in your feeder/screen manual.

9.12 TRACK GEAR

- Oil designation to DIN 51517, part 3: CLP 220.
- ISO viscosity to DIN 51519: ISO - VG 220.
- Kinematic viscosity at 40°C(104ÉF): Min. 198 mm²/s (cSt). Max. 242 mm²/s (cSt).
- FZG test A /8,3/90 to DIN 51354, p. 2: Min. breakdown load stage 12.

Recommended brands are e.g.:

- AGIP
 - Blasia 220
- ARAL
 - Degol BG 220
- AVIA
 - Gear RSX 220
- BP
 - Enersyn HTX 220
- CASTROL
 - Alphasyn T 220, Aplha ZN 220
- DEA

- Trion EP 220, Intor HCLP 220
- ELF
 - Reductelf SP 220, Elf Epona Z 220
- FINA
 - Giran L 220
- FUCHS
 - Renolin AWD 220
- KLÜBER
 - Lamora 220
- KUWAIT
 - Q8 Goya 220, El Greco 220
- MOBIL
 - Mobilgear 630, SHC 220
- PANOLIN
 - EP Gear Synth 220
- TEXACO
 - Syngear 220
- TOTAL
 - Varter EP 220

9.13 GREASE

The grease must be NLGI EP 2 Type. Grease containing Molybdenum additives in NOT recommended.

9.14 ADDING HYDRAULIC FLUID

Adding hydraulic oil:

- open the oil addition plug in the top of the return filter (refer to 3.11)
- add oil through the return filter in order to prevent impurities from entering the hydraulic system
- the correct hydraulic oil level is in the middle of the upper sight glass

NOTE: The unit must be in operating and horizontal position when the hydraulic oil level inspection is carried out.

9.15 ADDING ENGINE FLUIDS

Adding engine oil:

- add engine oil through oil fill port of the engine (refer to 3.10 a), #4).
- check the amount of oil with dipstick (see 9.7 Filling volumes)

9.16 REMOVING ENGINE/HYDRAULIC FLUID

Observe the following instructions:

- remove the plug
- open the valve
- make sure that the drain pan will be able to hold all the fluid (see 9.7 Filling volumes)
- dispose oil according to local regulations

Drainage plugs are shown in the figure 3.9 (#14 coolant water, #15 engine oil, #17 hydraulic oil).

9.17 ENGINE FUEL FILTER REPLACEMENT

Please, refer to the Caterpillar C-9 Operation and Maintenance Manual.

Fuel System Primary Filter/Water Separator - Drain (refer 3.10 figure a), #2).

Fuel System Primary Filter/Water Separator Element - Replace

Fuel System Secondary Filter - Replace (refer to 3.10, figure b), #3).

Chapter 10

Service instructions

SERVICE INSTRUCTIONS

10.1 GENERAL	10-1
10.2 BATTERY MAINTENANCE	10-2
10.3 OTHER ELECTRICAL EQUIPMENT.....	10-3
10.4 WELDING	10-3
10.5 PRESSURE ACCUMULATOR.....	10-3
10.6 CRUSHER SPEED SENSOR	10-4

10.1 GENERAL

Only skilled and experienced mechanics must be allowed to service the plant.

In any work related to the operation, adaptation to manufacture, conversion or adjustment of the Lokotrack and its safety equipment, as well as to inspection, maintenance and repair, observe starting and stopping procedures in accordance with the Instruction Manual and any indications relating to maintenance work!

Secure extensively, as far as necessary, the area of maintenance works!

In case the Lokotrack is completely switched off during maintenance and repair works, it must be safeguarded against unexpected switching-on. Lock-up main starting equipment, draw off keys and affix a hazard pictorial at the main switch.

Smoking and any open flame is prohibited in the immediate area of the machine when refuelling or servicing the fuel system.

In case of fire:

- Move the Lokotrack away from the dangerous area
- Stop the engine
- Turn off the main switch
- Start fire fighting and give the alarm if necessary.

Diesel fuel is flammable - do not use as cleaning fluid. Use solvents of accepted quality only.

Always stop the engine during maintenance unless it is mentioned in the instruction manual to keep the engine running.

Do not check for leaks with a bare hand, use suitable cleaning cloth.

Never adjust any hydraulic valve beyond the pressure recommended by the manufacturer.

Always ensure adequate ventilation when running the engine in a confined area.

Remember that some solvent qualities may cause skin irritation and may be extremely inflammable. Avoid breathing of solvent fumes.

Service facilities must be kept clean. Oil and water can make floors slippery and highly dangerous. Avoid severely soiled clothing, they can be a fire hazard.

Keep the Lokotrack and equipment free from oil spillage and dust. A clean machine reduces the fire risk and simplifies visual checks for components requiring attention.

Be careful when using pressure cleaning equipment. Even low pressures and temperatures can damage wire insulation.

Check wiring for signs of abrasion damage or kinks. This can cause short circuits and fire.

Check hydraulic hoses for abrasion damage or kinks.

Never weld or grind containers of inflammable liquids.

Always have a fire extinguisher on hand when carrying out welding or grinding operations.

Notify the location and use of fire extinguishers.

10.2 BATTERY MAINTENANCE

Fluid level check

The fluid level in the batteries must be checked every 100 operating hours (figure 10.2.1). The level should be approximately 10 mm(1/4") above the plates. Add clean distilled water as required. Monitoring the fluid consumption will give an indication of the charge of the battery, but a separate test of the specific gravity of the acid will confirm the state of charge. If the fluid consumption is high it is possible for the alternator charging rate to be too high.

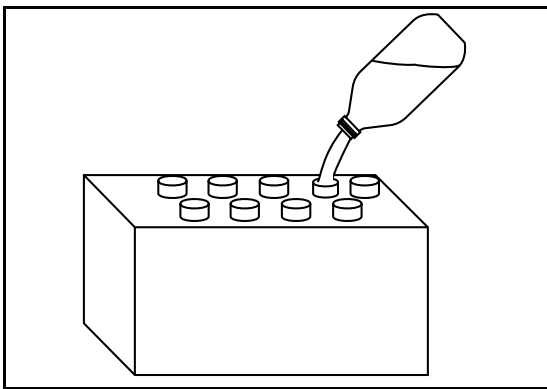

Figure 10.2.1 Check battery fluid level every 100 operating hours. Add clean distilled water in the accumulator as required

Battery check

The level of charge in the battery must be checked regularly using a hydrometer. Do not make this check immediately after adding any distilled water to the battery; the water and acid will be more evenly mixed after some charging has taken place. The specific gravity of a fully charged battery is approximately 1.28, and if only half-charged the reading will be about 1.2. These values relate to a battery temperature around +20°C(68°F).

Batteries must always be maintained as far as possible at full charge. If the charge is allowed to remain low, the plates will become sulphated reducing the capacity and efficiency of the whole battery.

Remember that a half-charged battery will freeze at a temperature of -25°C(-13°F) and a flat one at only -10°C(14°F).

Never use an open flame when checking the acid level of a battery. The gases given off by the chemical reaction during the recharging process are highly inflammable.



The liquid used in lead-acid batteries is dilute sulfuric acid. This acid is corrosive, will cause severe burns to exposed skin and will damage clothing. Be very careful when handling a battery.

Always wear protection glasses and gloves while handling and maintaining.

Cleaning batteries, terminals and cables

Batteries and terminals must be cleaned at least once per year. The terminals and the cable ends should be cleaned with the special tools which will restore the contact area to the right form and size. After cleaning, the terminals and cable ends should be liberally covered with petroleum jelly to protect against oxidation. Check also the fastening of: battery earth cables to the main frame, engine starter cables, and electrical connections for the alternator. Clean and tighten as necessary. Keep battery cases clean and dry.

10.3 OTHER ELECTRICAL EQUIPMENT

Charging circuit

- Check and tighten connections regularly.
- The alternator requires only periodic attention.

It is important to strictly follow the instructions for protecting the alternator:

- Do not remove battery cables or any other connections in the charging circuit while the engine is running.
- Never start the engine if any wire in the charging circuit is disconnected or loose.
- Whenever the batteries are charged using an external source, the earth lead to the frame must be disconnected from the battery. When reconnecting batteries, using jumper leads or a charger, be sure to identify the correct polarities.
- Always disconnect the batteries when servicing the electrical equipment of the Lokotrack.
- Do not cause a short circuit in any part of the system, nor take a test reading with an instrument with low internal resistance.

If auxiliary batteries are used to assist engine start, make sure that:

- batteries have the same voltage
- the correct poles are connected

Starter circuit

Normally the starter circuit requires little attention, but all components should be kept clean and electrical connections tight. The batteries are an essential part of the electrical system and are required to be kept fully charged, clean and topped up properly to maintain the acid level. Battery cables must also be checked for tightness and kept clean and greased.

10.4 WELDING

If any welding is to be done on the machine, care must be taken to protect sensitive electrical equipment.

- Stop the engine.
- Turn the main switch OFF.
- Disconnect the earth lead to the batteries.
- Fasten the earth cable of the welding apparatus as close to the part to be welded, as possible and make sure that no welding current is able to pass through any bearings or electrical equipment.

10.5 PRESSURE ACCUMULATOR

NOTE: Before removing / repairing any components from the hydraulic setting control circuit release the pre-charge pressure by opening the SHUT off VALVE. Make sure that the pressure gauge above accumulator indicates NO pressure. Make sure that the security valve of the gauge is open.

10.6 CRUSHER SPEED SENSOR

FUNCTION

The crusher is equipped with a speed sensor. The sensor controls the pitman rotation and gives one impulse per one pitman revolution.

MOUNTING

The sensor is mounted at the back side of the pitman, close to the eccentric shaft. To locate the sensor, lift the rubber cover behind the pitman.

The sensor is mounted on its support with a plastic clamp. The correct distance from the sensor end to the pitman is 3-5 mm. (The minimum distance while the crusher is running). When replacing the sensor there is no need to adjust the sensor itself.

Sensor has a LED-indicator. The function can be controlled from this led indicator.

Possible reasons if the speed sensor is causing an alarm:

- Chocked fuel filter
- Chocked air filter
- V-belts are loose - slipping
- The setting too small for the crushed material
- Cavity worn out.
- Hydraulic drive component failure

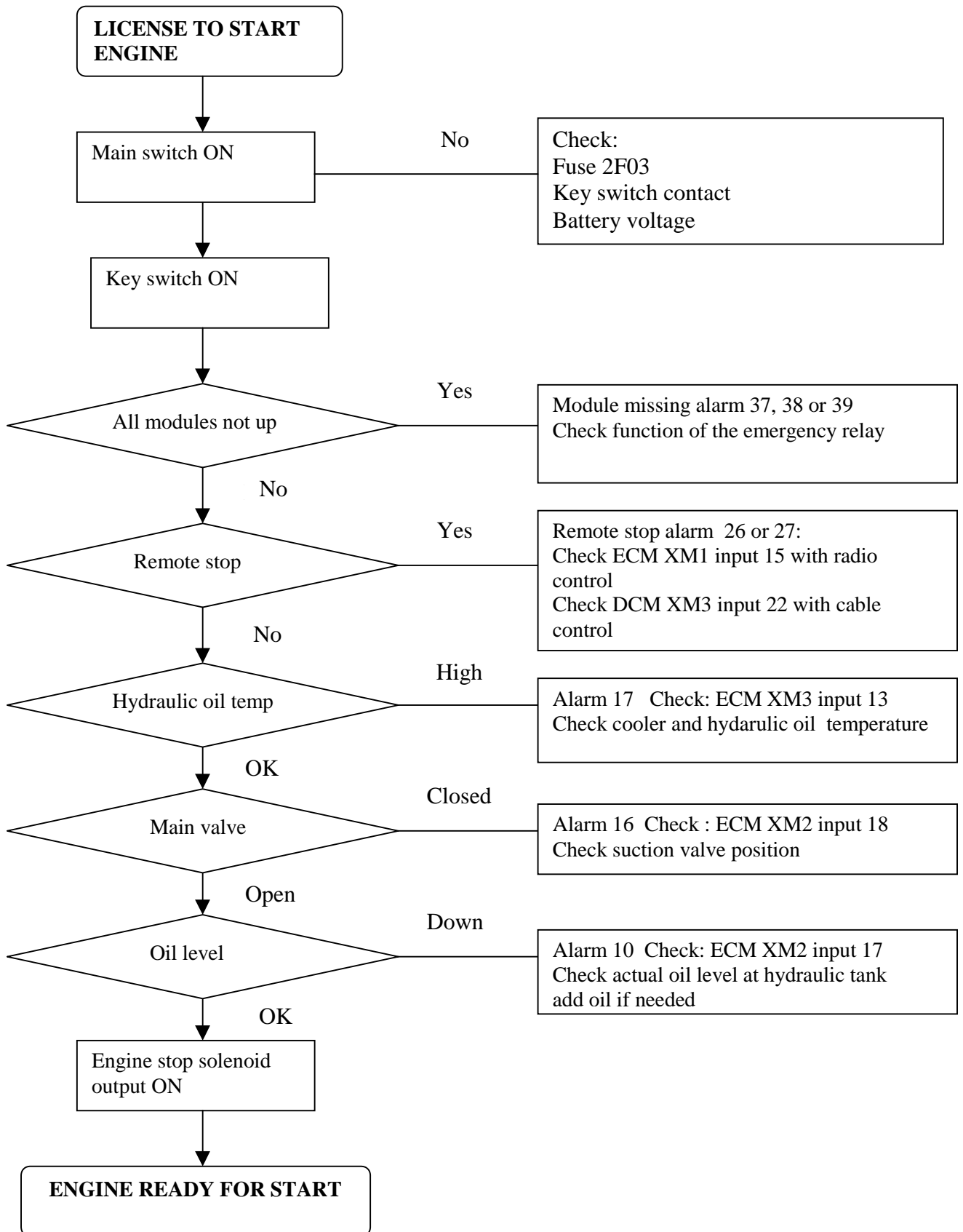

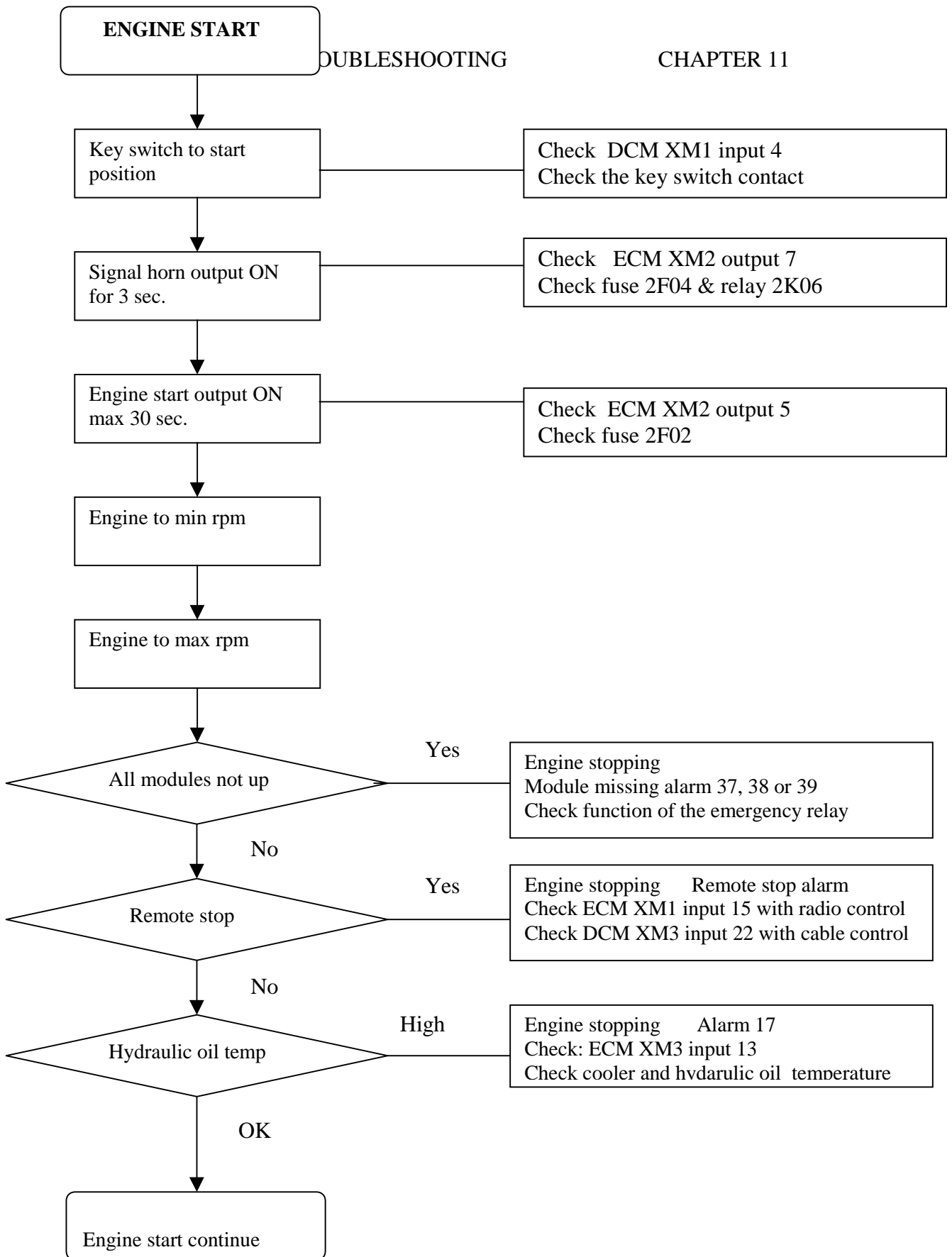

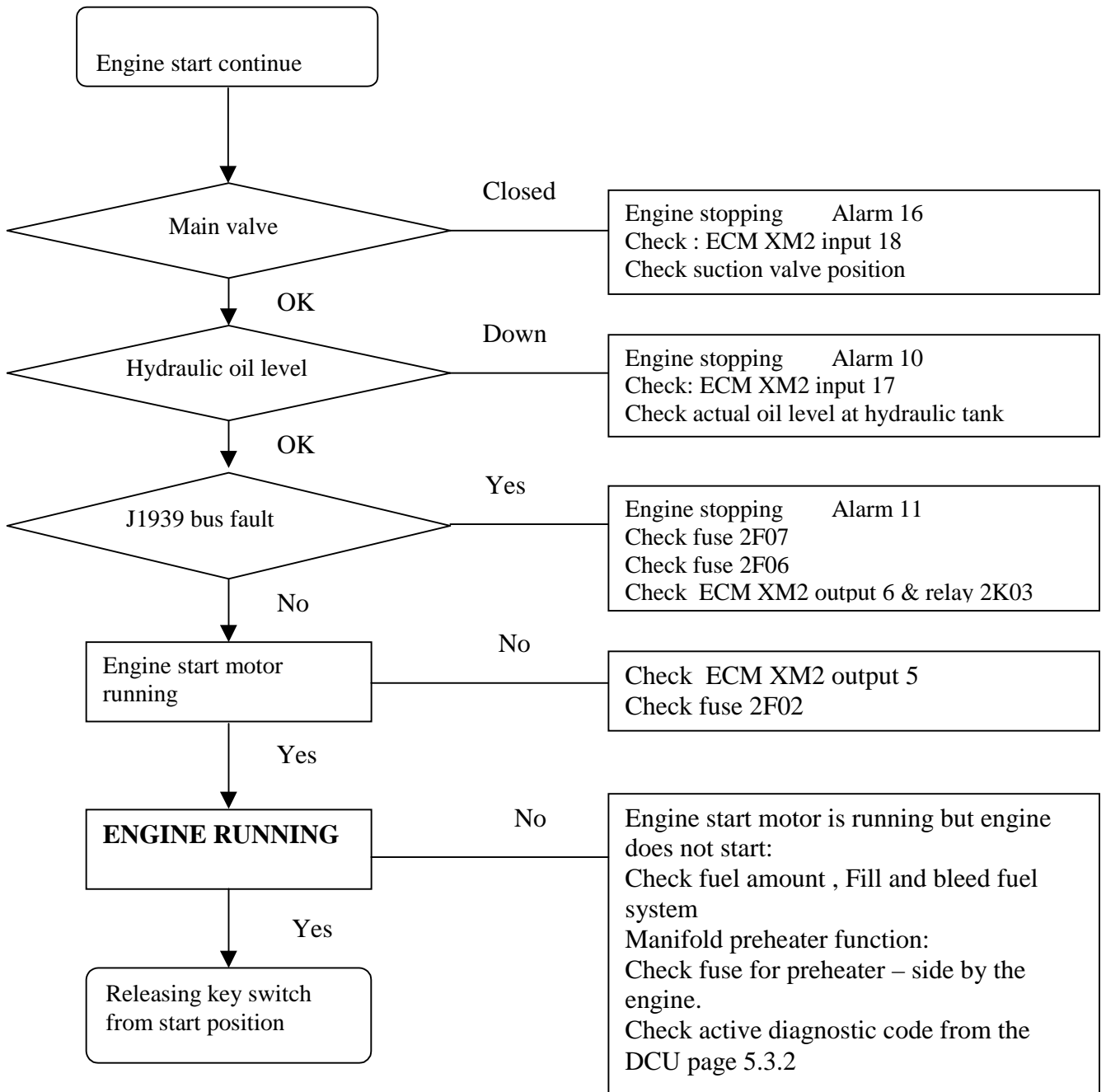

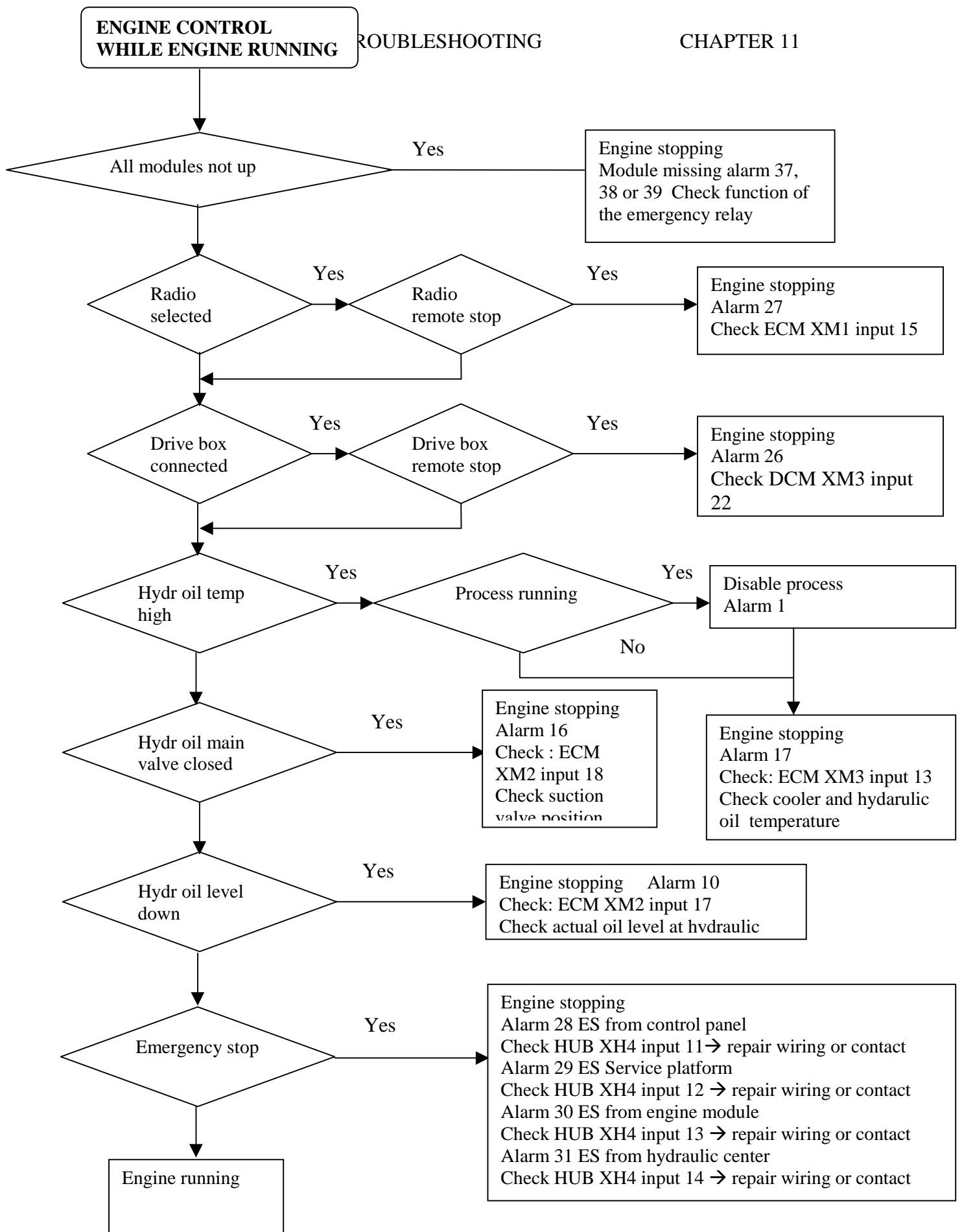

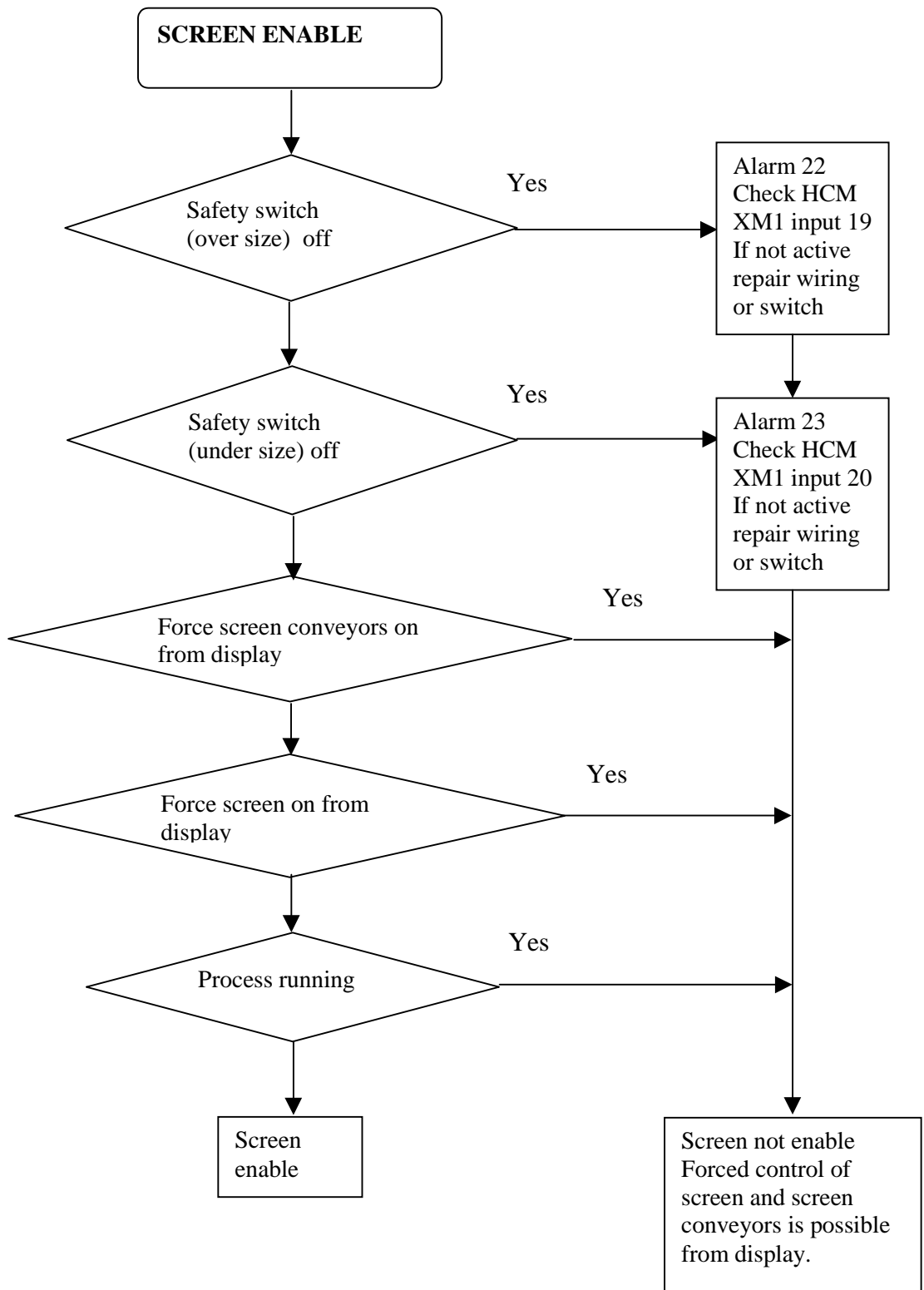

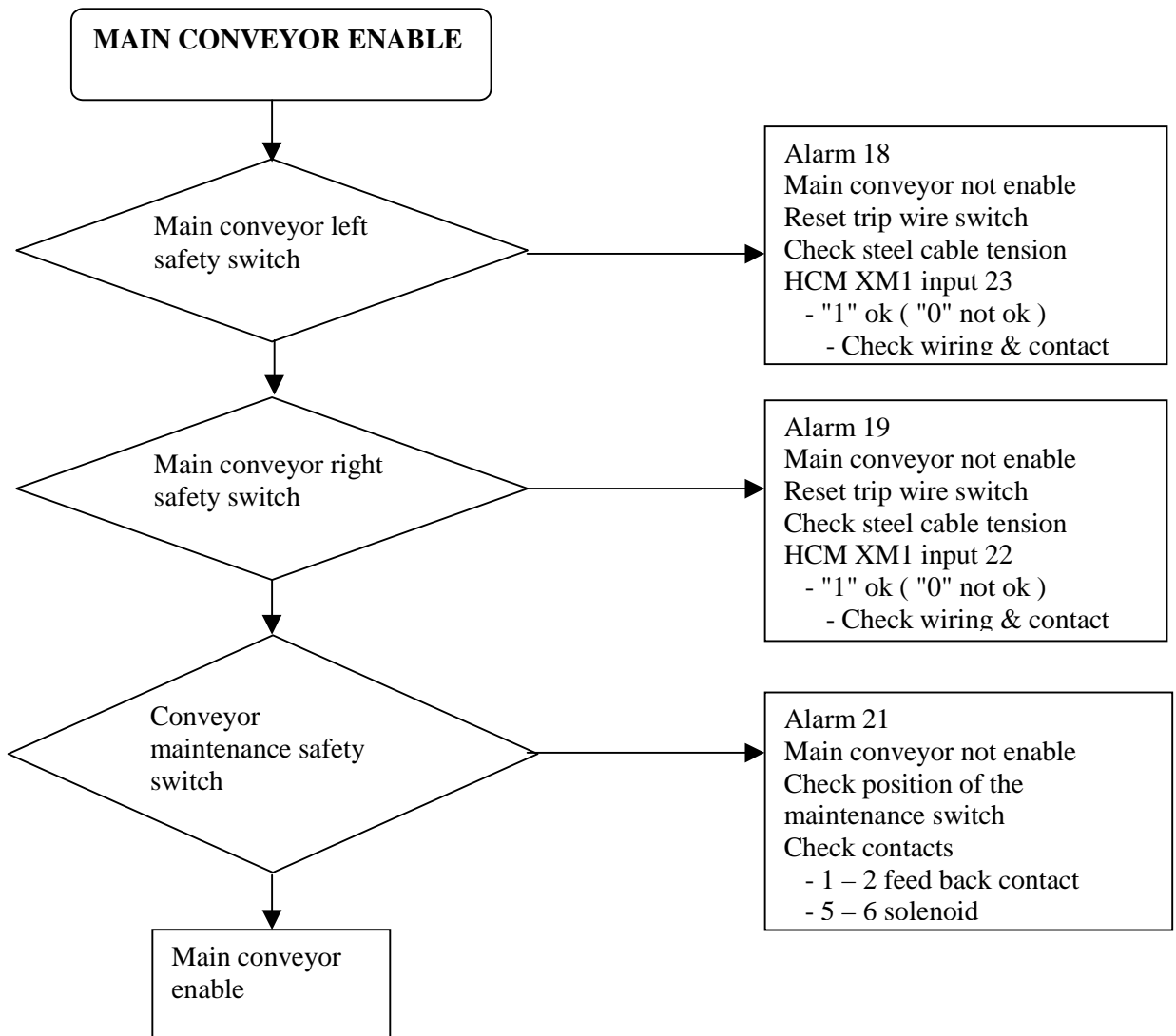

CRUSHER START UP AND STARTING BY PROCESS

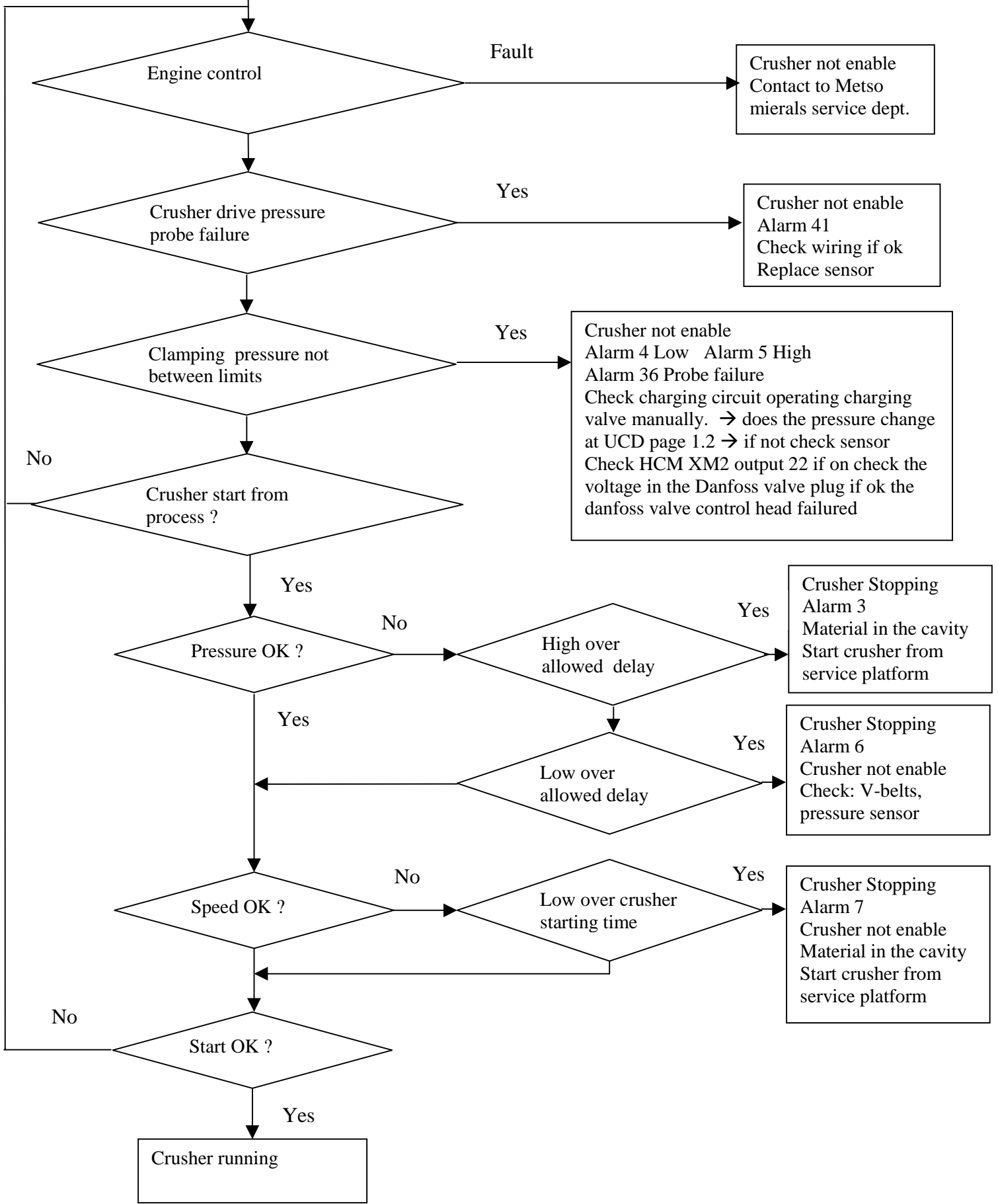

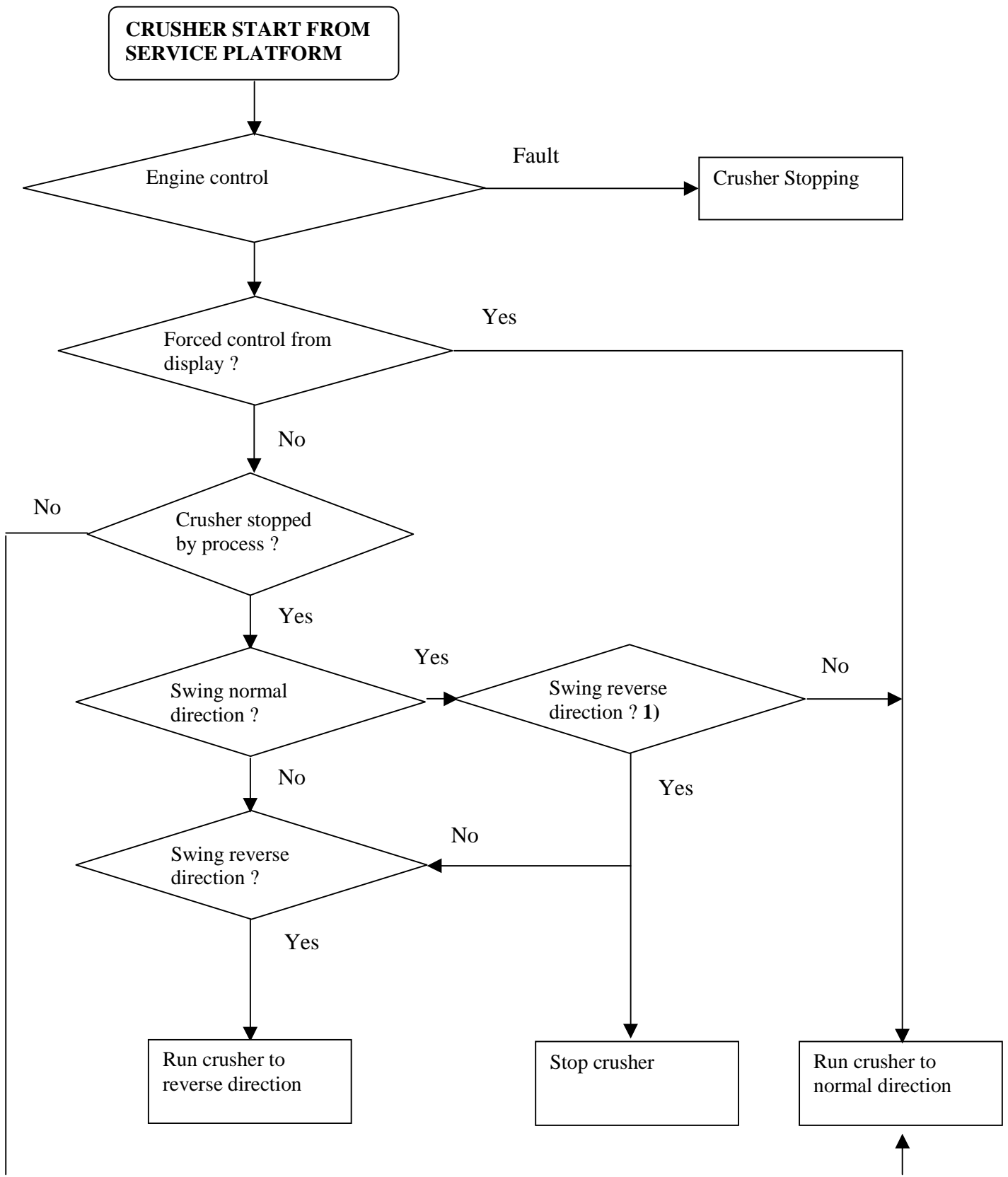

1) If swing normal direction and reverse direction are activated simultaneously

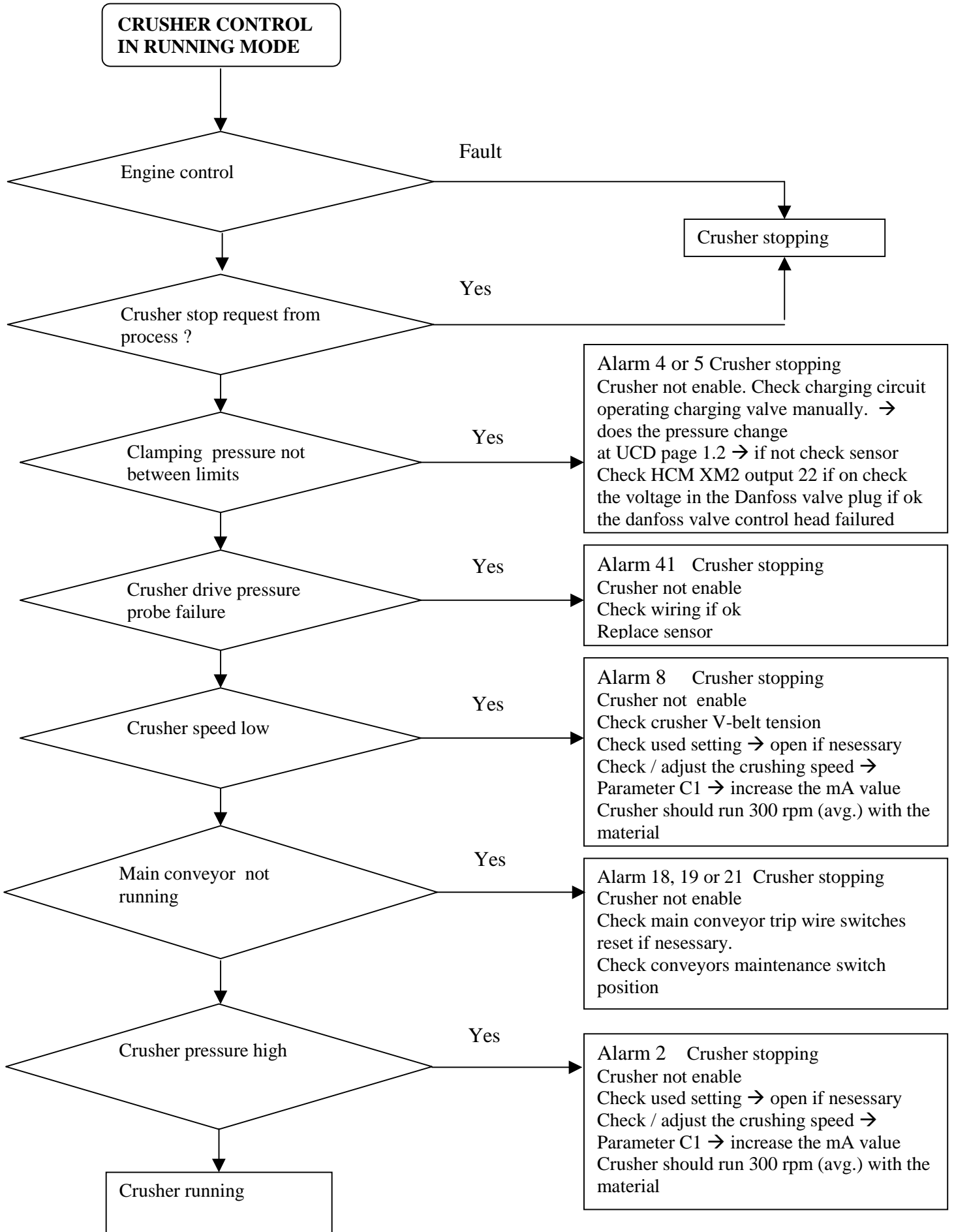

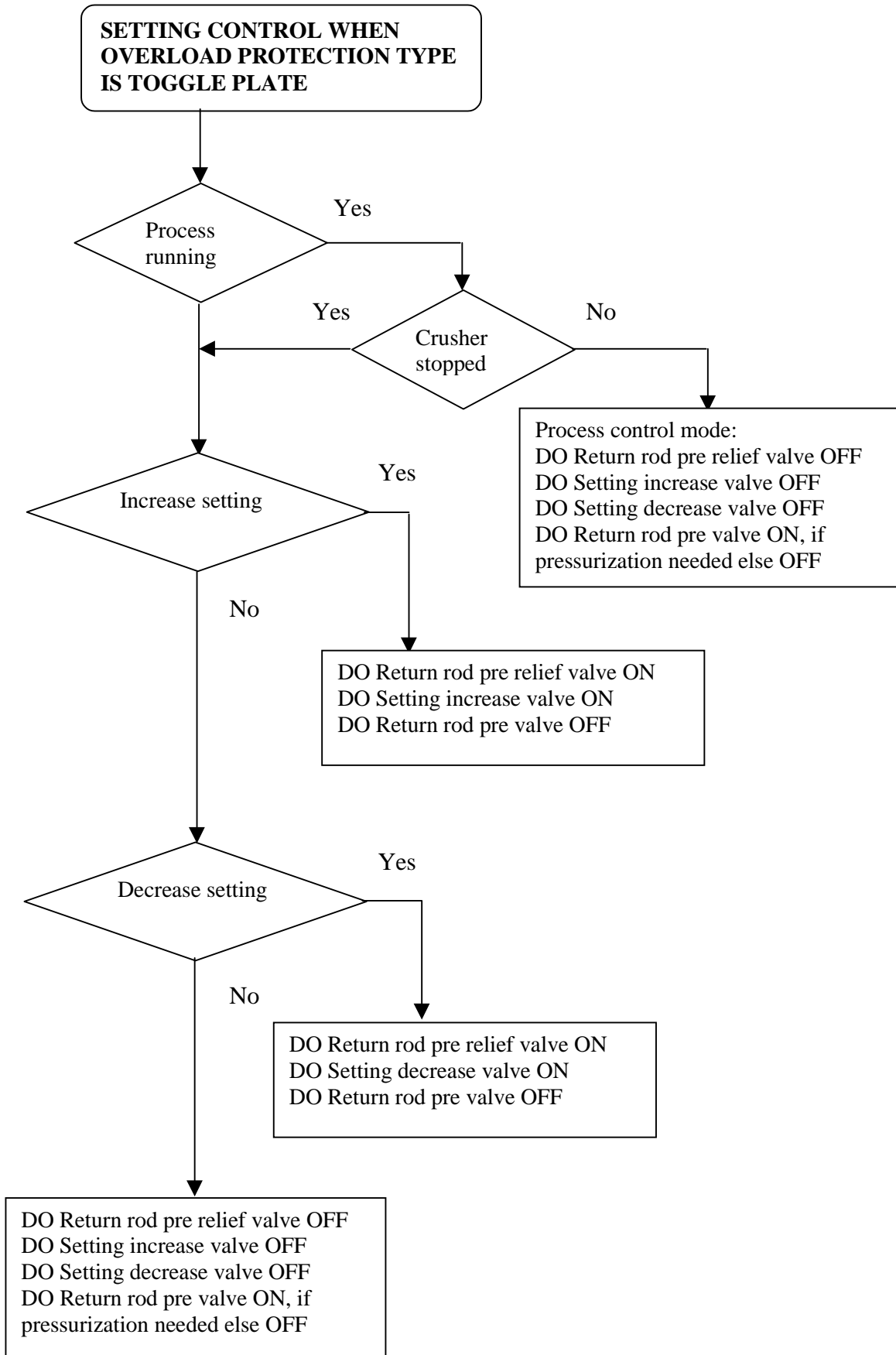

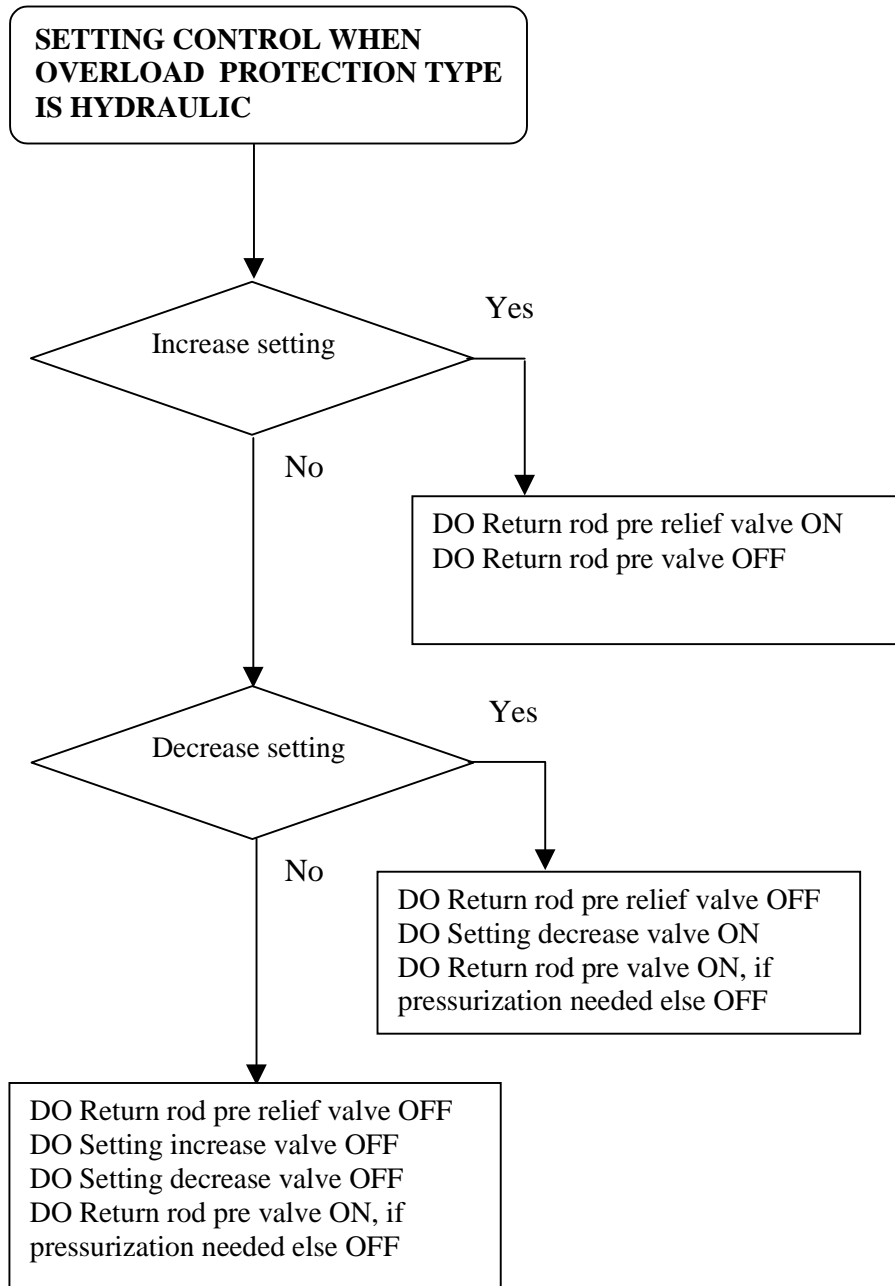

**CRUSHER OVERLOAD:
DETECTION AND
SETTING CONTROL**

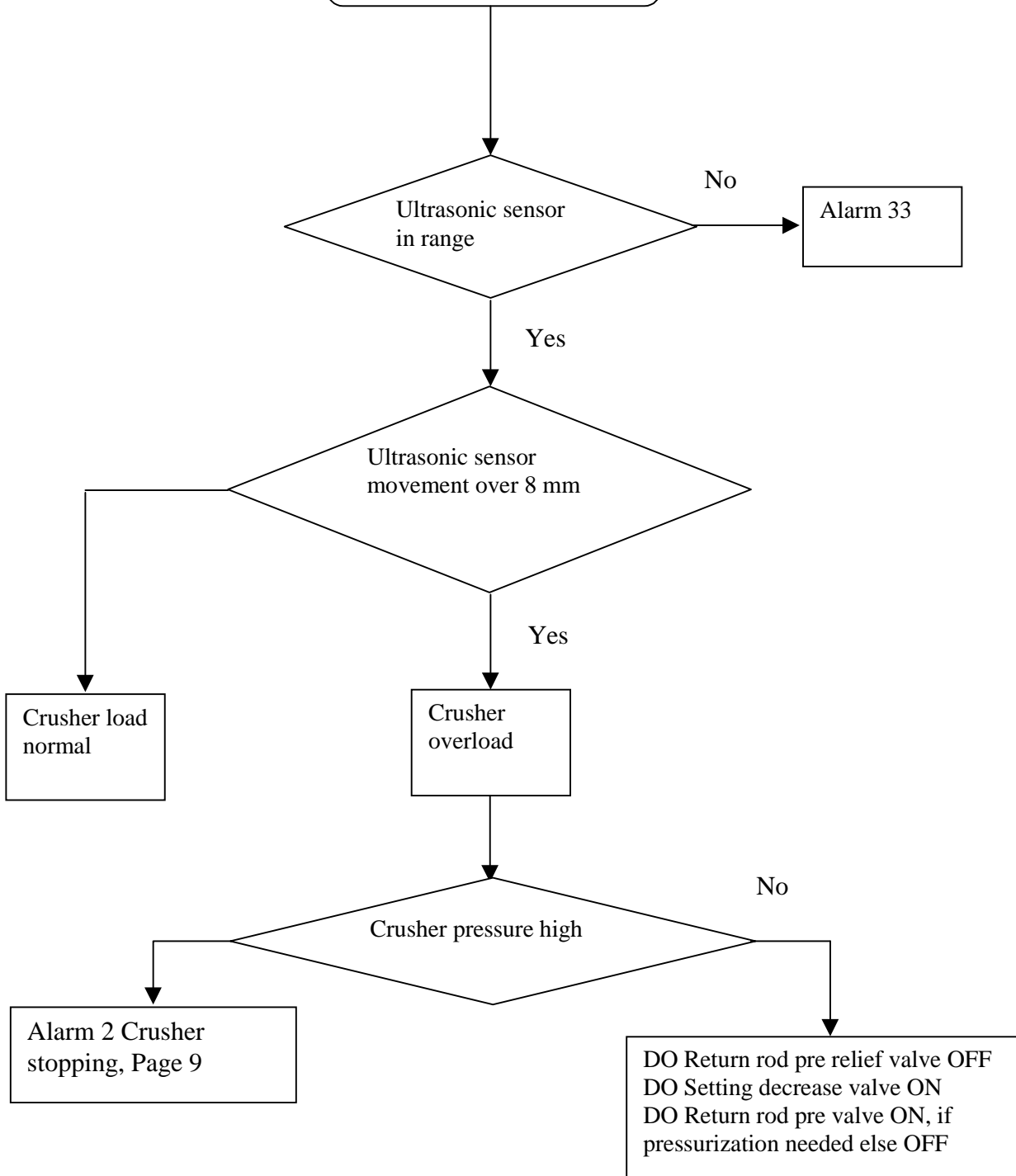

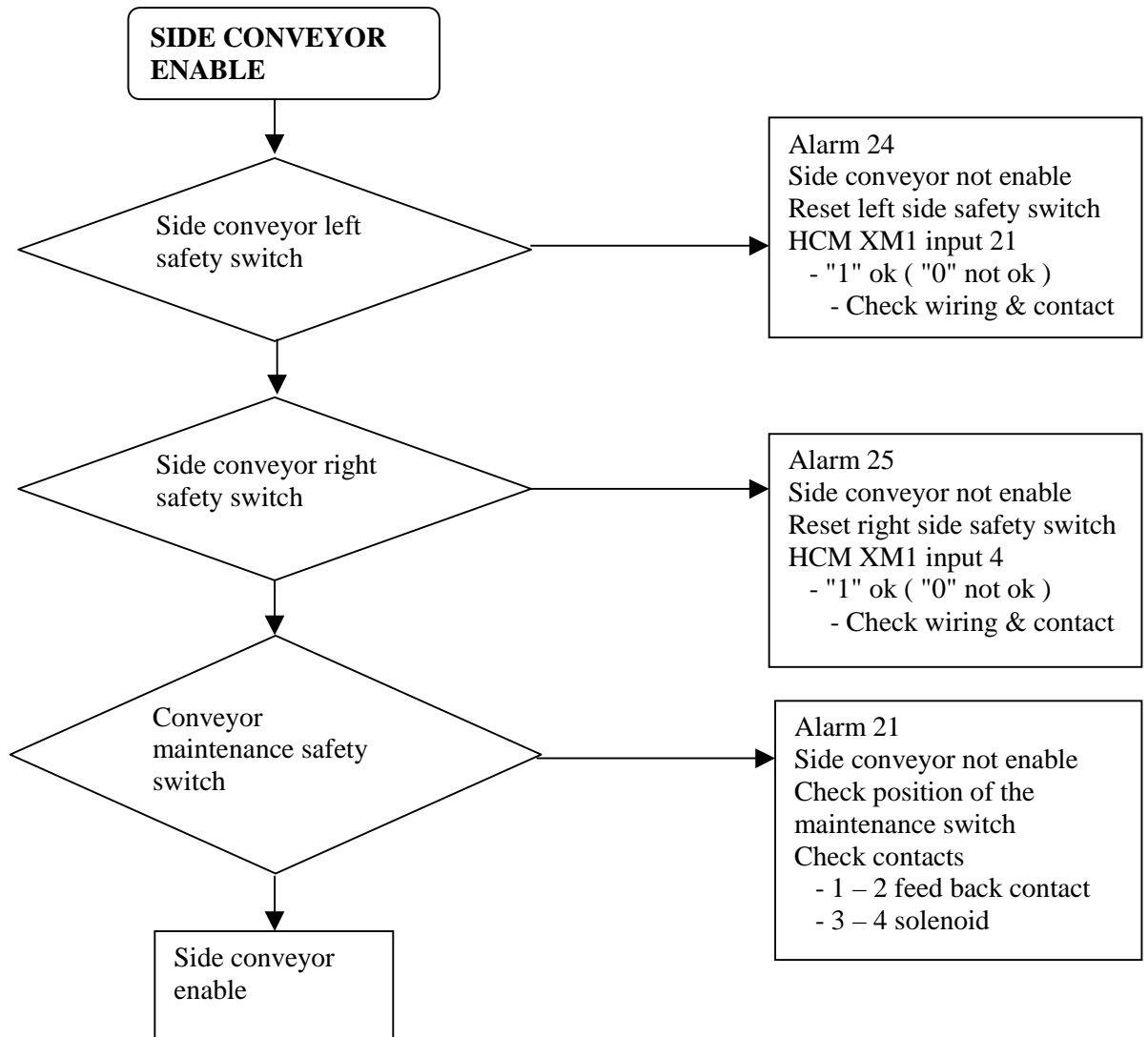

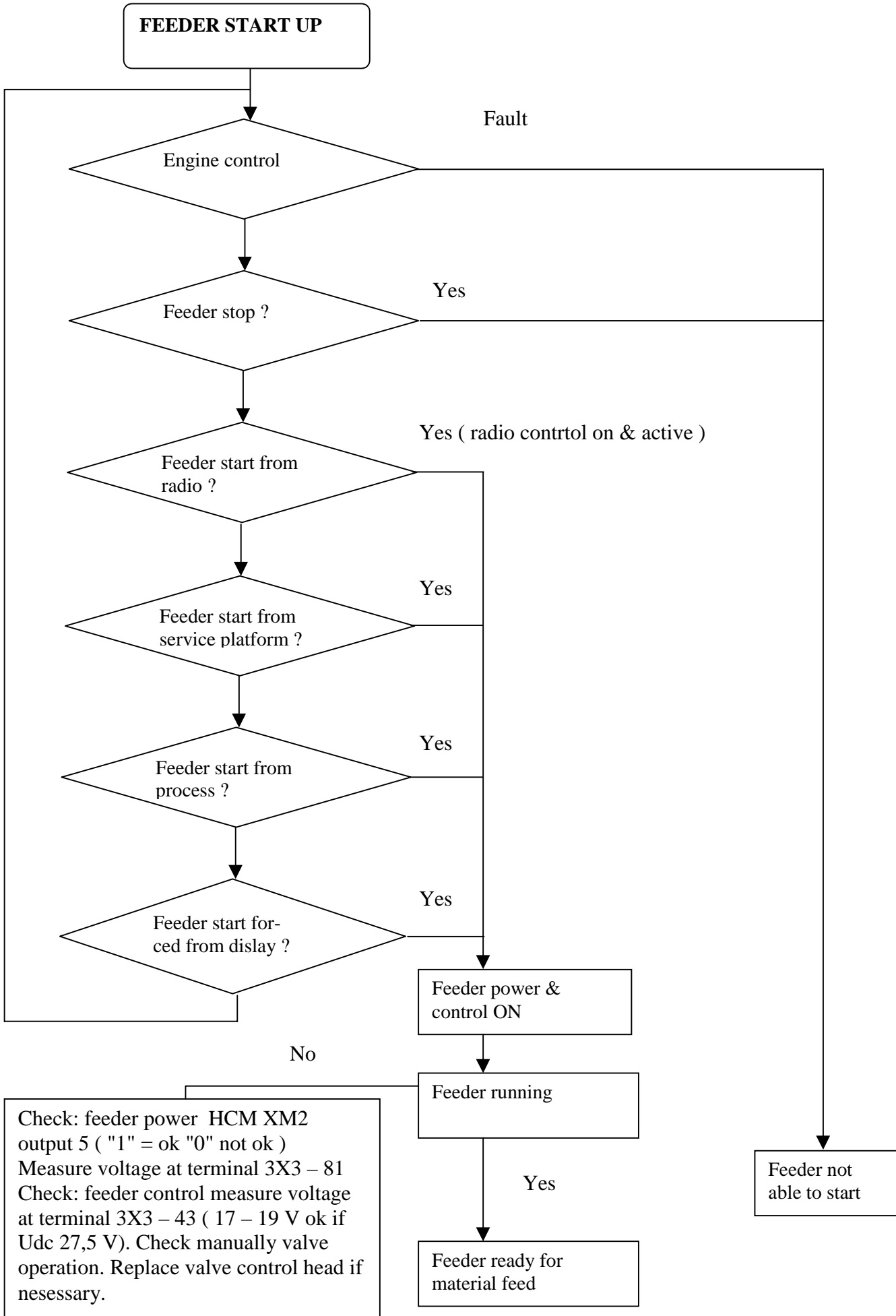

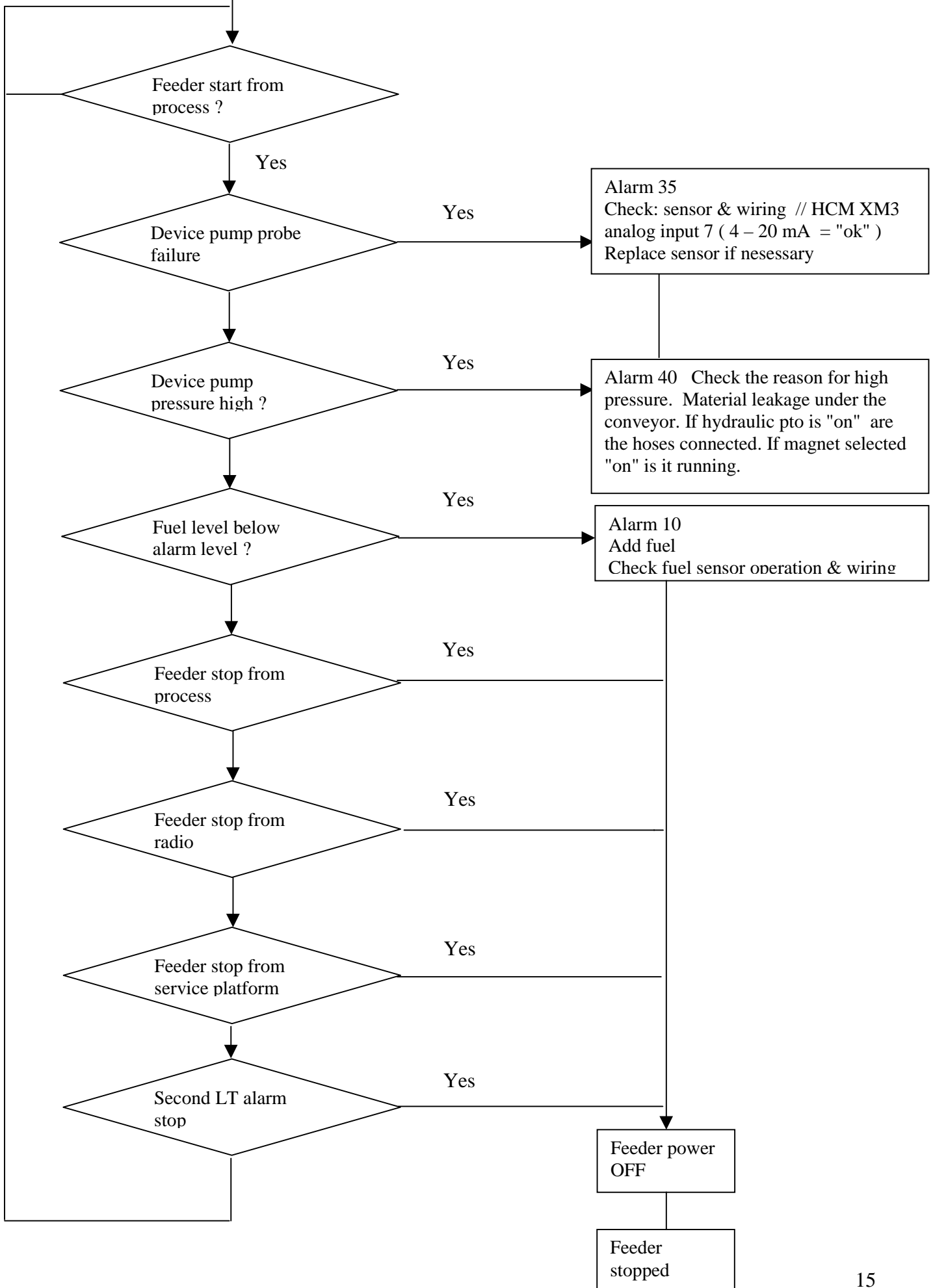

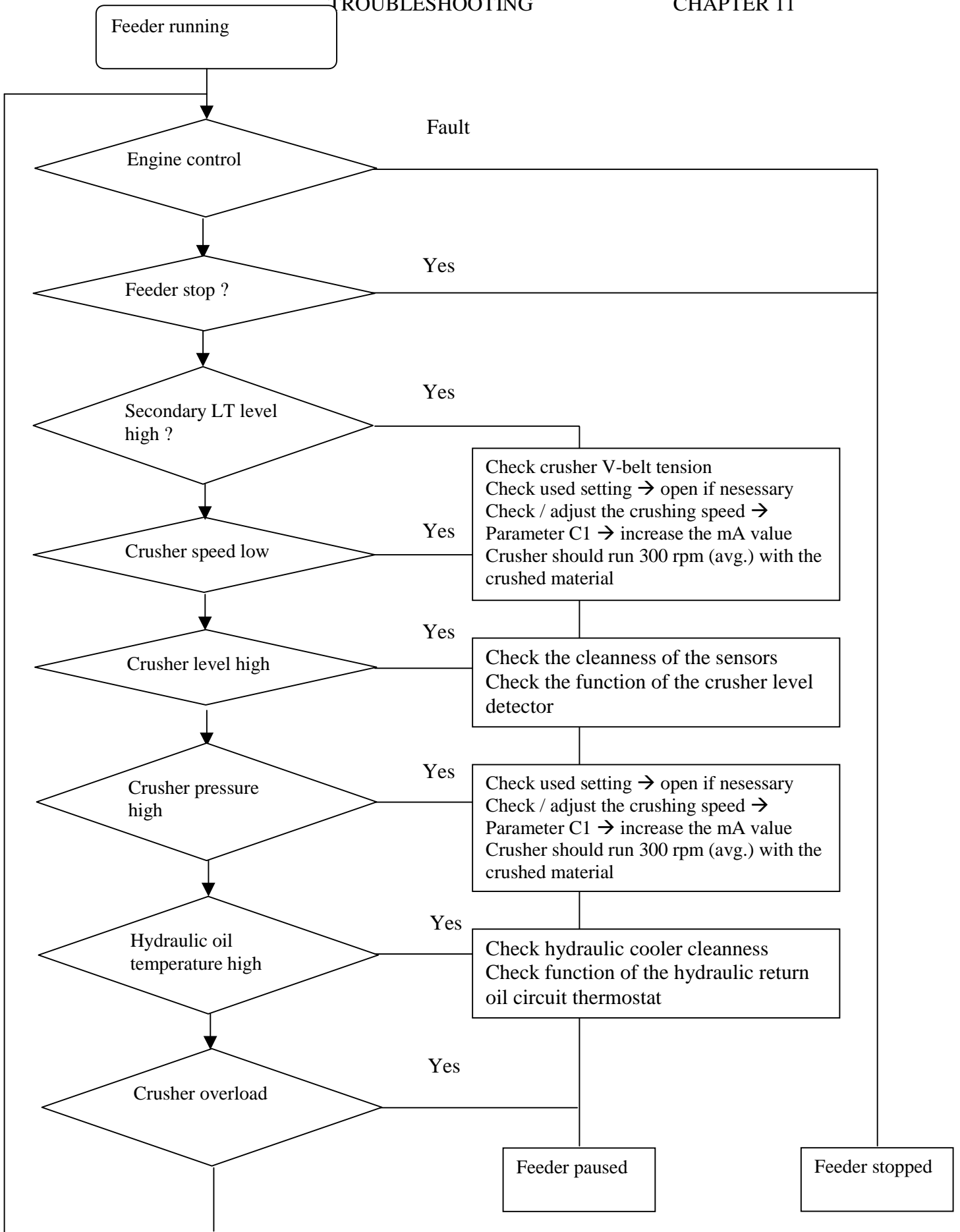

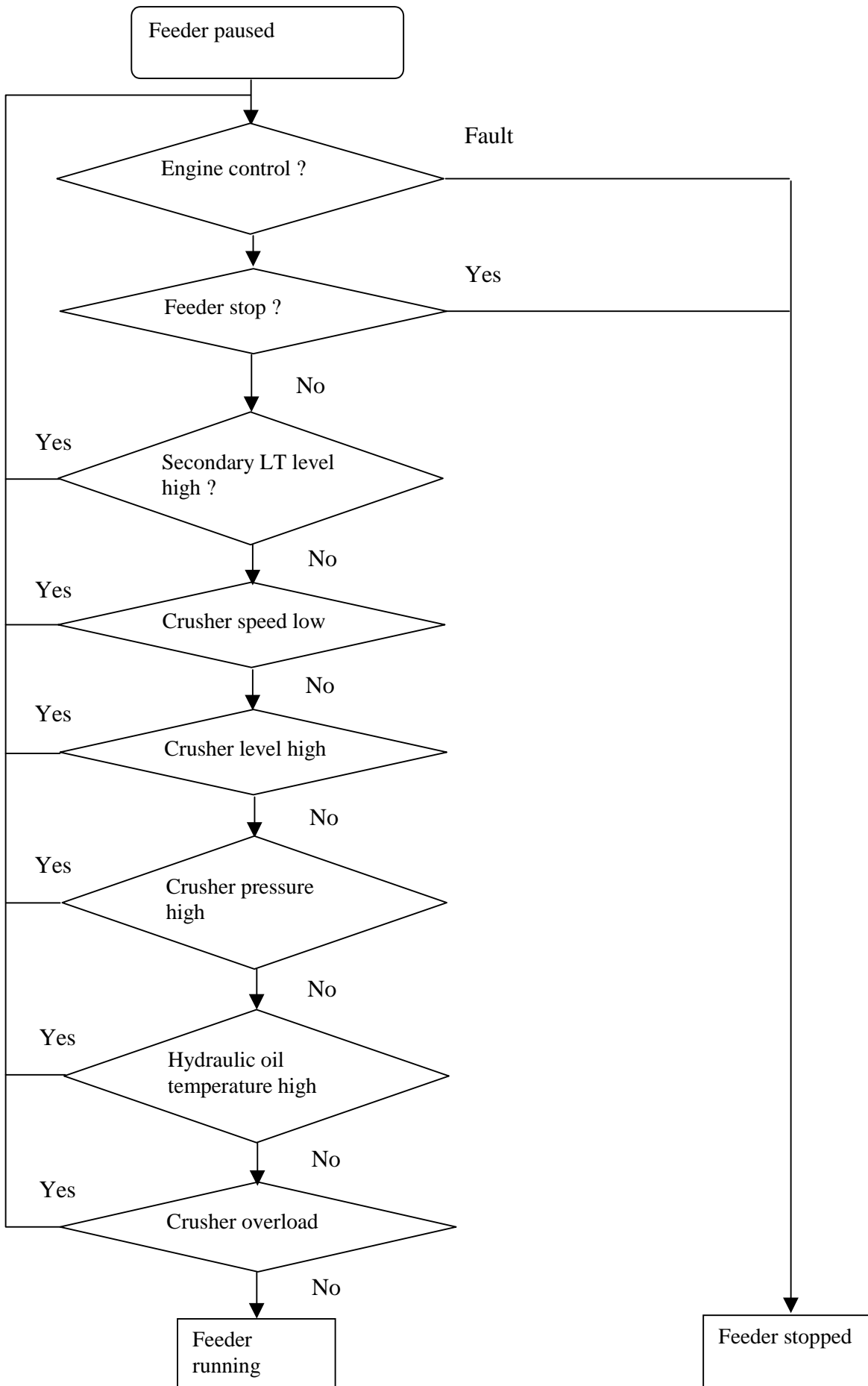

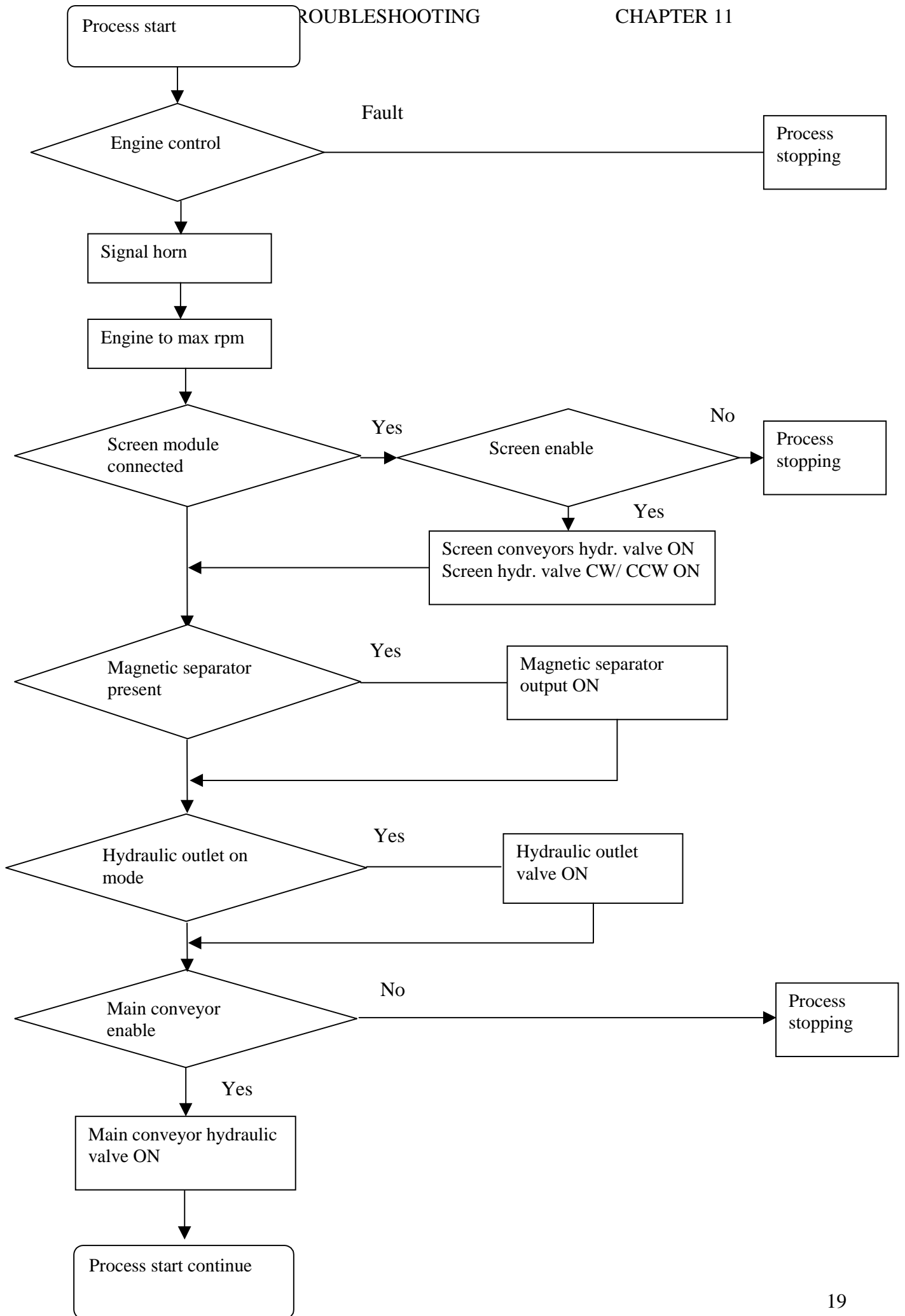

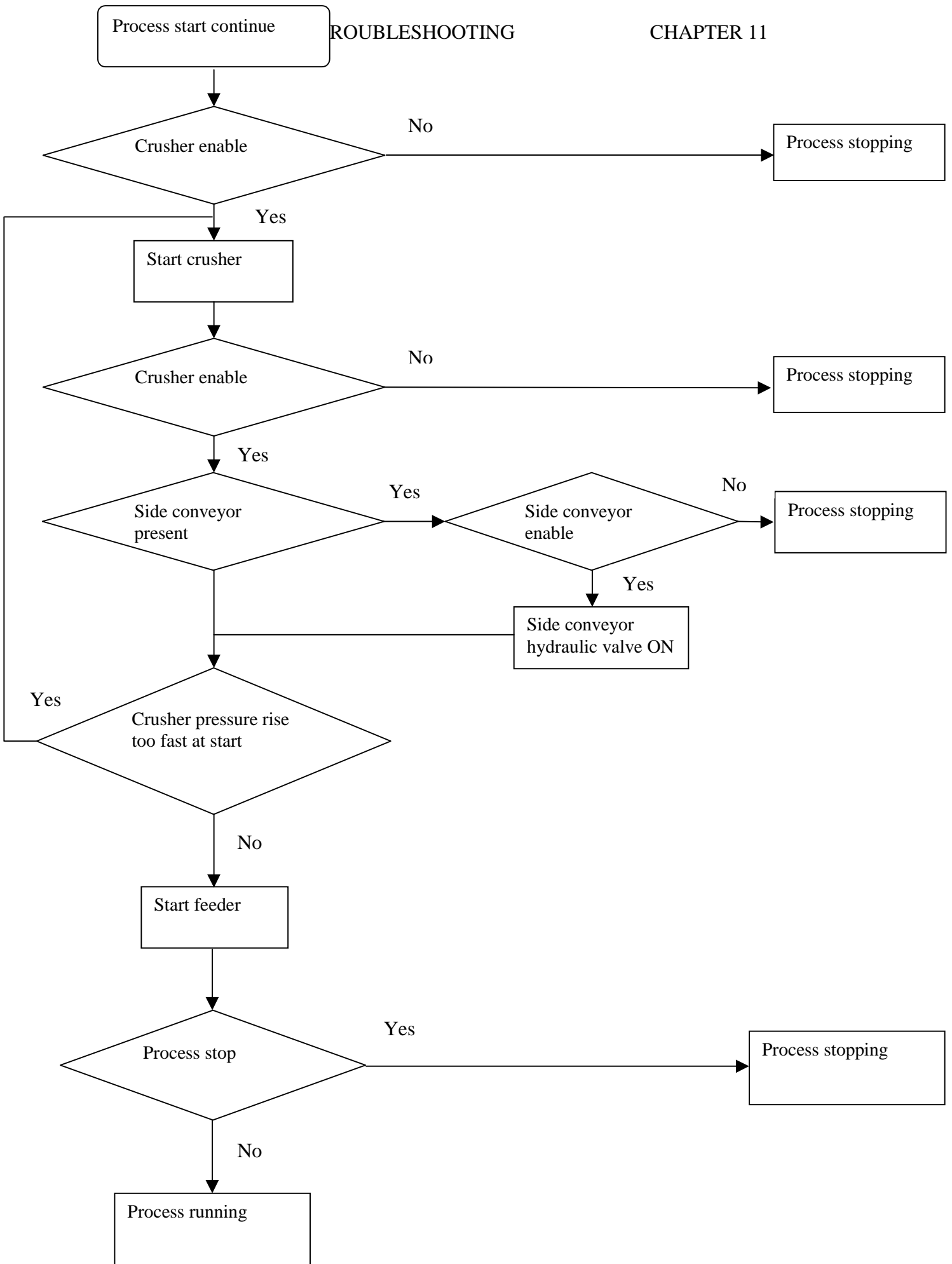

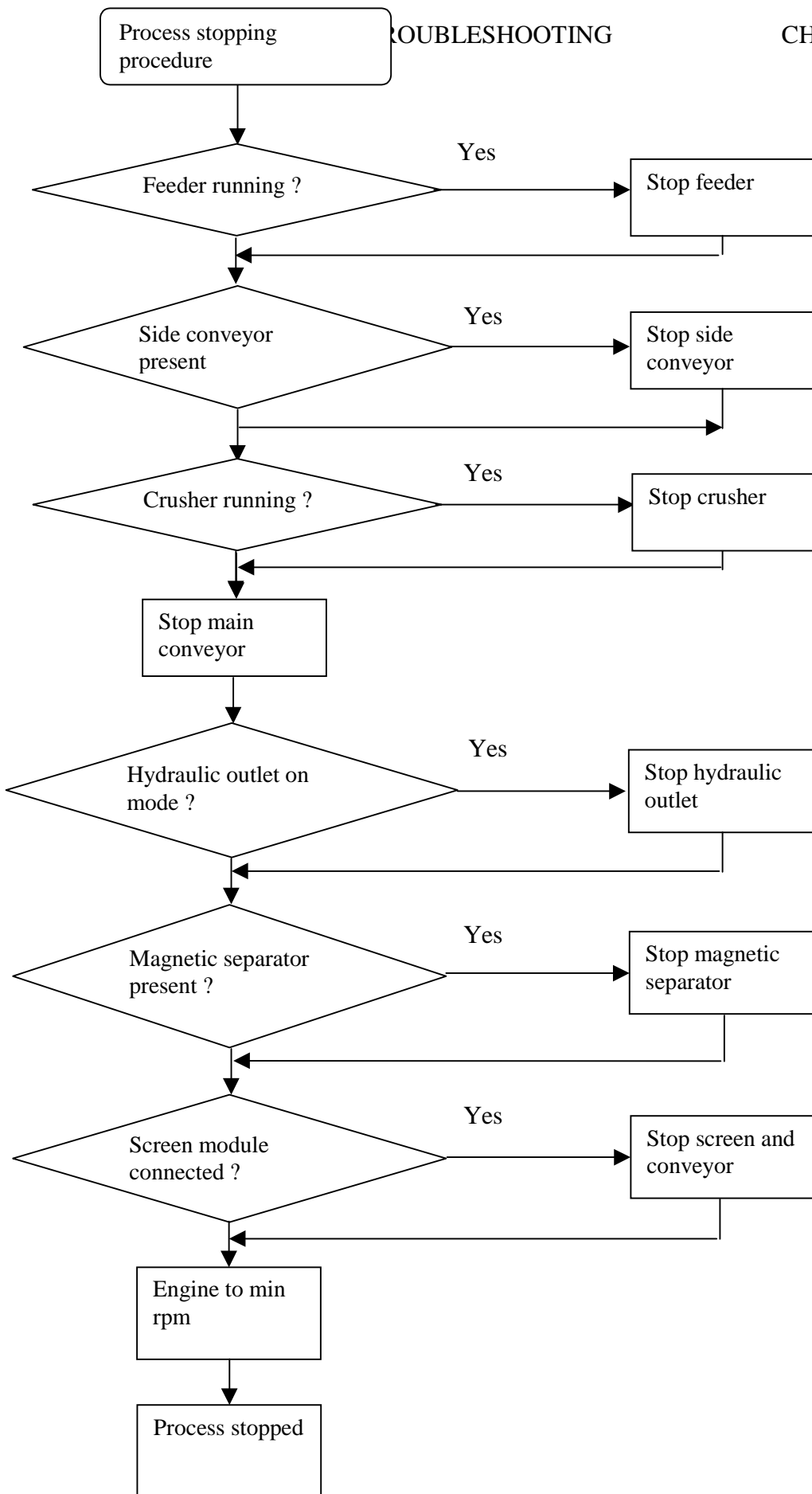

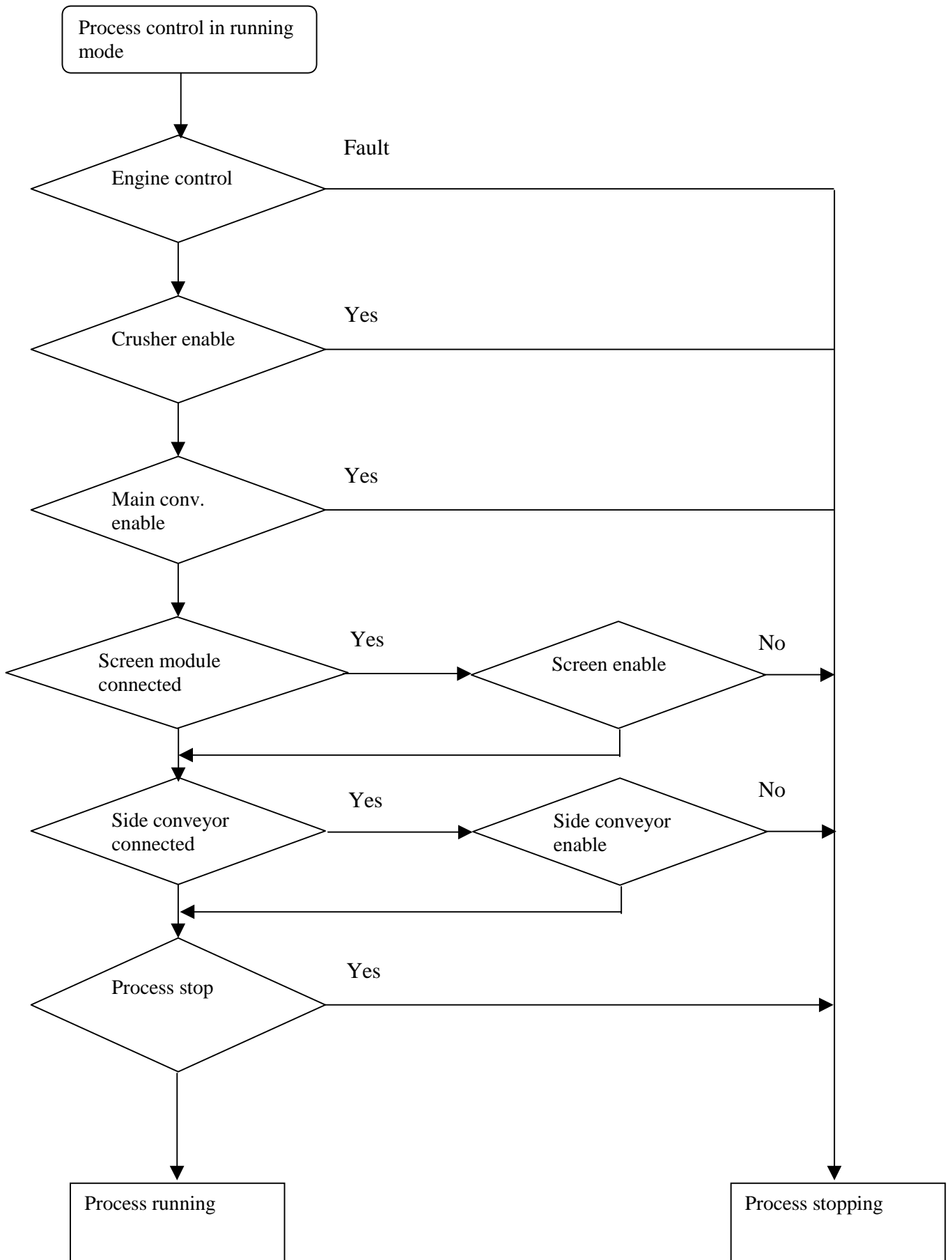

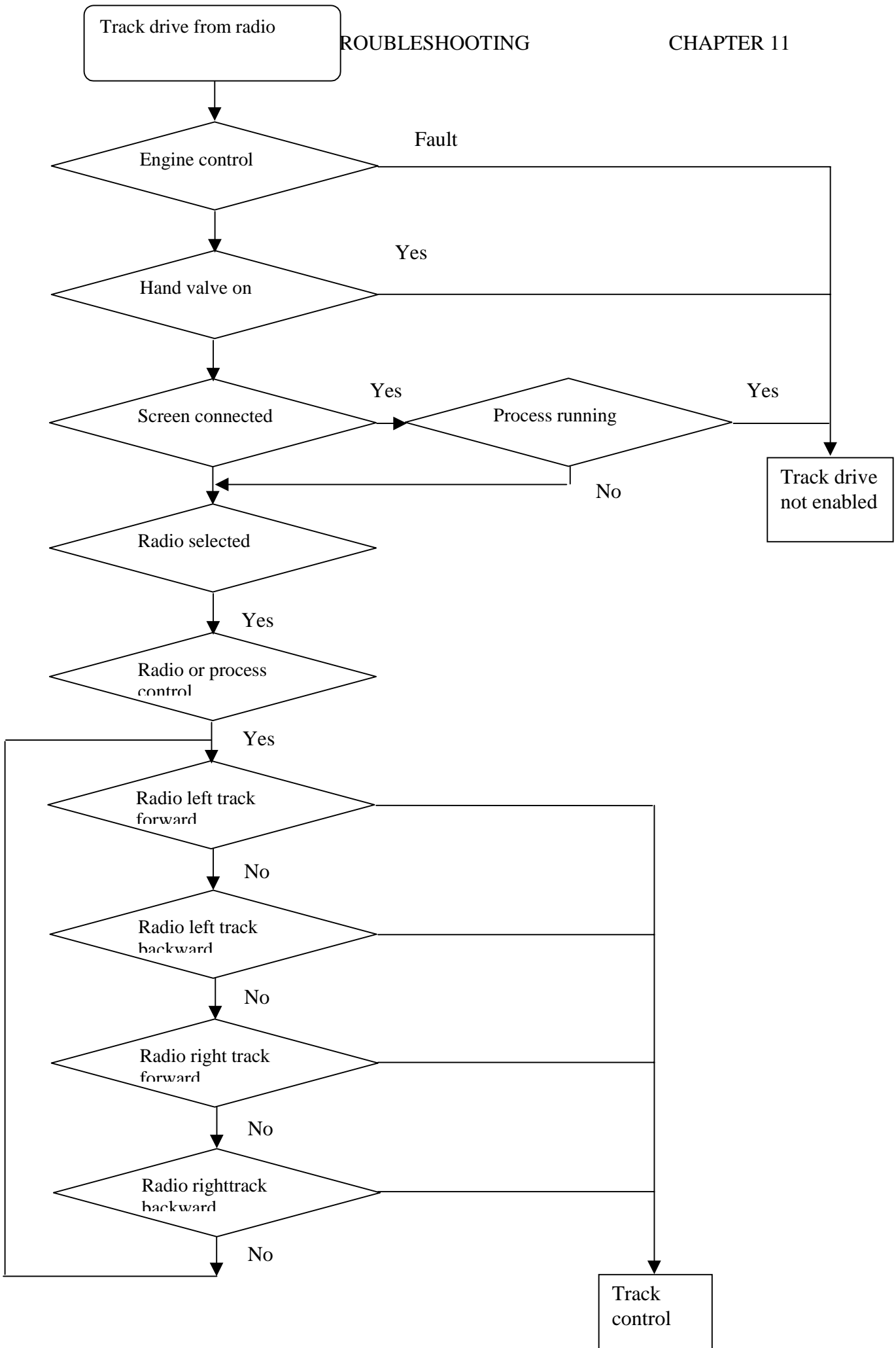

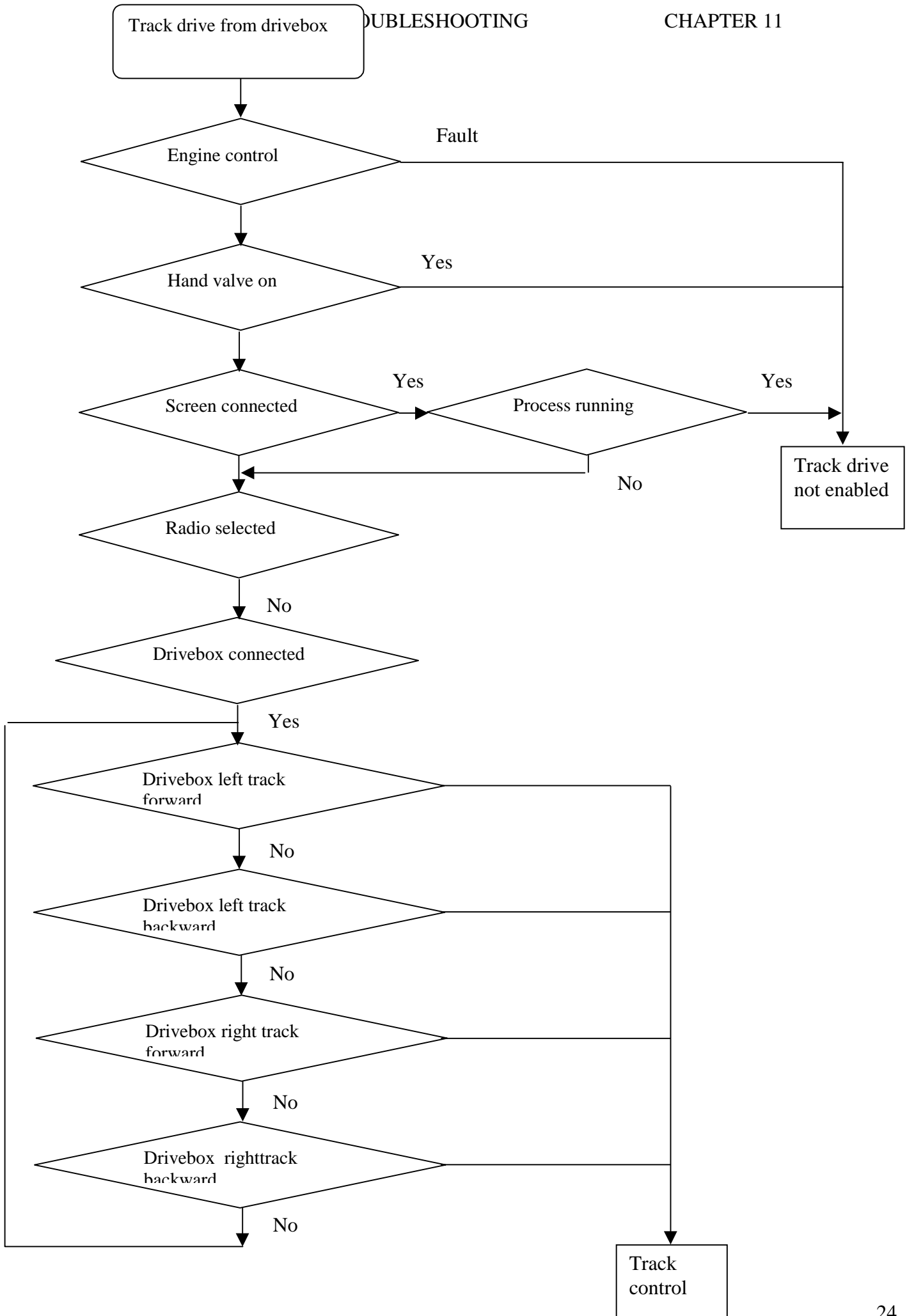

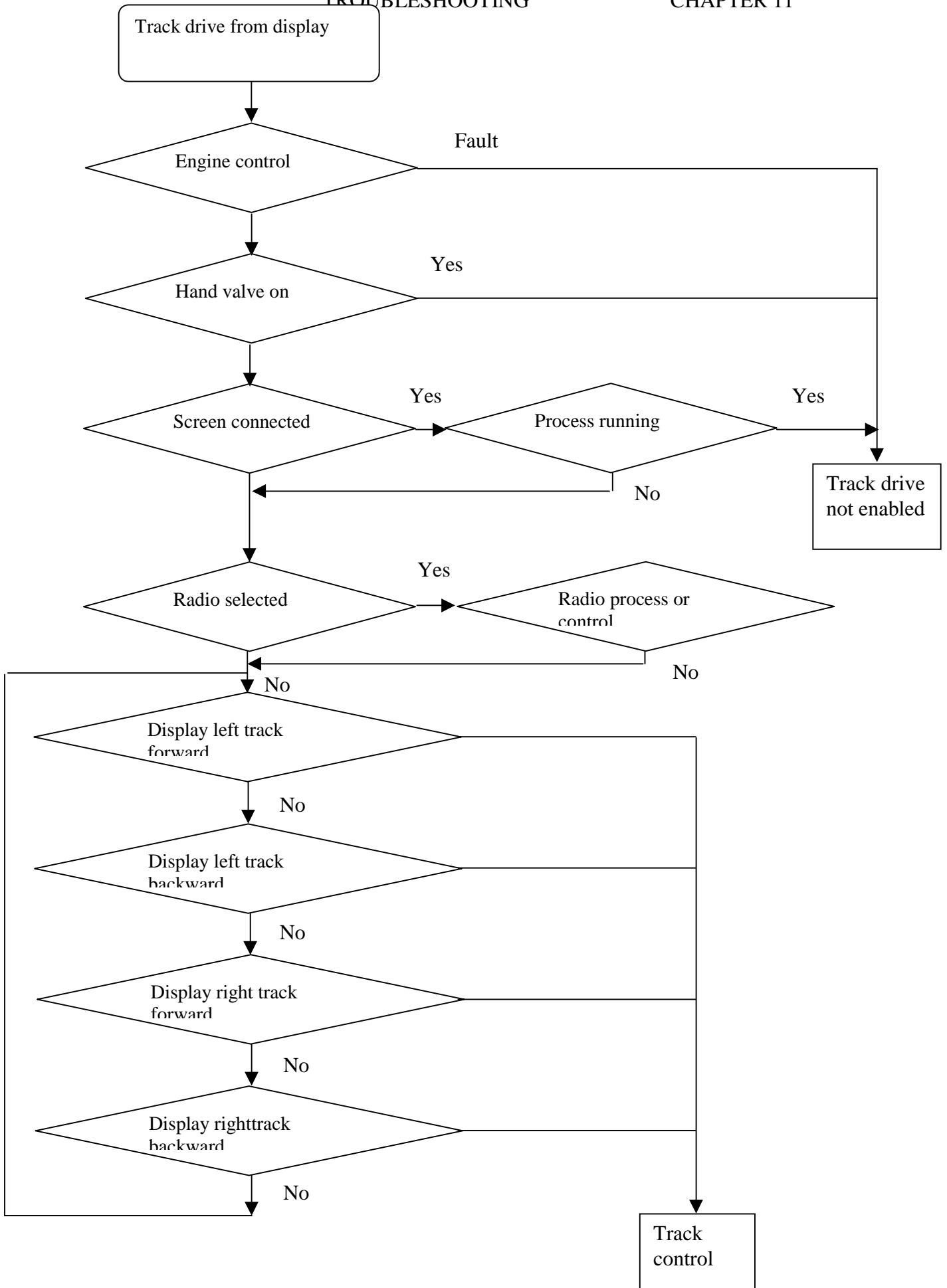

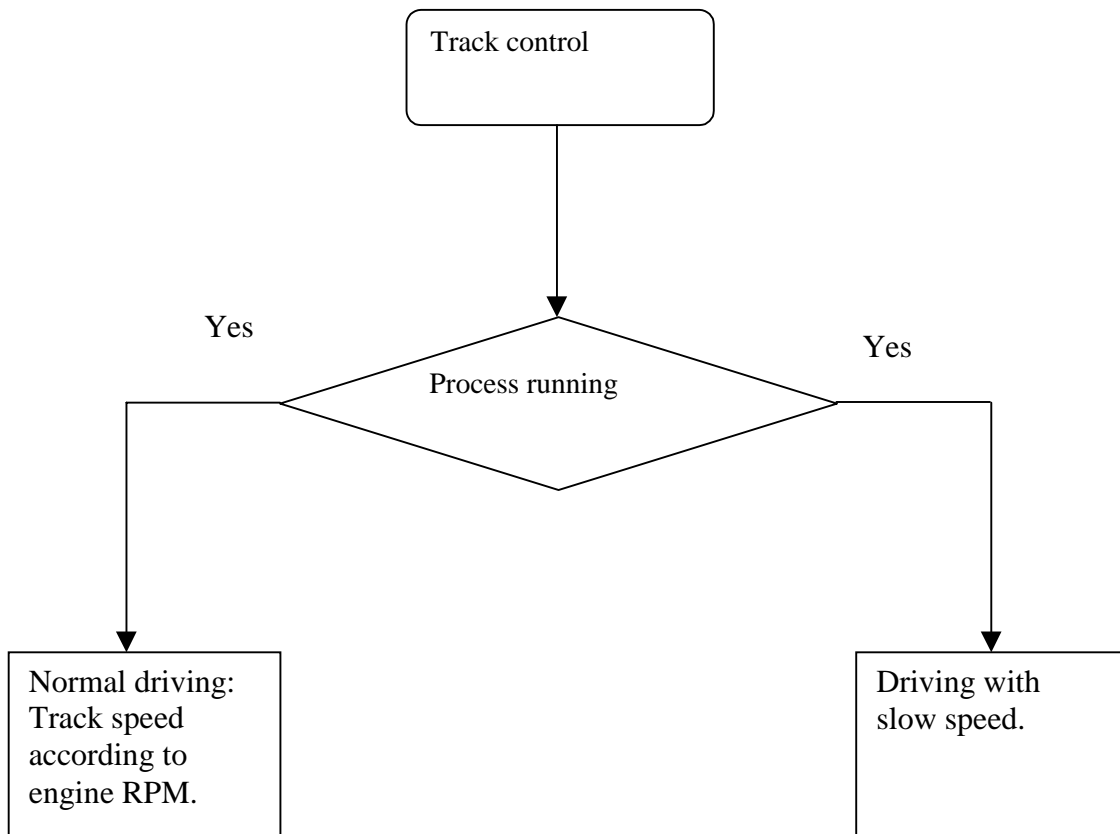

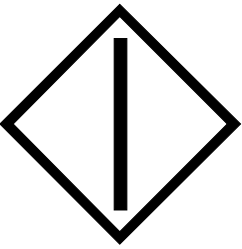
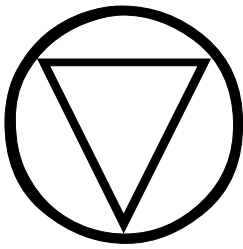
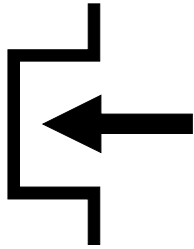
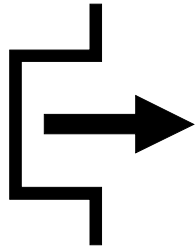
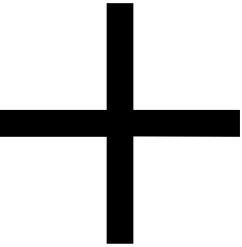



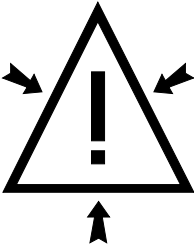
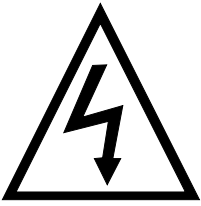

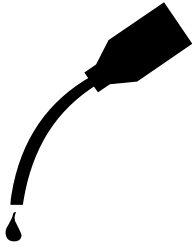
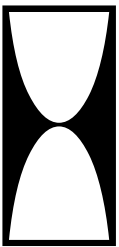
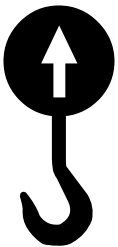

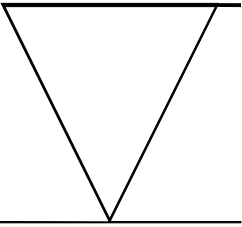
1.General symbols			
			
1. On/Start	2. Off/Stop	3. Connecting	4. Disconnecting
			
5. Increase	6. Decrease	7. Stepless adjustable movement	8. Warning
			
9. Warning: pressurized	10. Warning: electric danger	11. Grease lubrication point	12. Oil lubrication point
			
13. Running hours	14. Lifting point	15. Horn	16. Level

1. General symbols

17. Belt conveyor	18. Feeding	20. Check	21. Max. temperature

2. Electric symbols





1. Remote control	2. Battery charging indicator

3. Lights

1. Work light	2. Driving lights

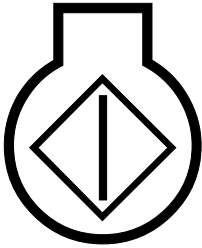
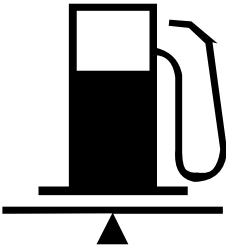
4. Engine

1. Engine emergency stop	2. Stopping of engine	3. Engine running speed	4. Combustion engine

4. Engine			
			
5. Starting of engine			
5. Fuel			
			
1. Fuel volume	2. Fuel pressure	3. Fuel filter	4. Fuel shut-off
			
5. Fuel refill			

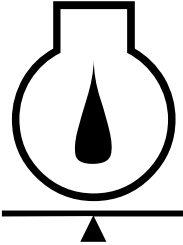
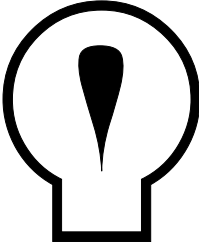
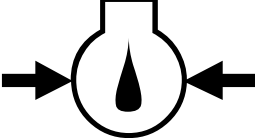
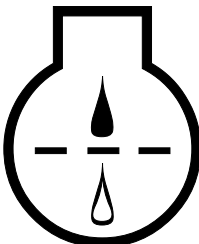

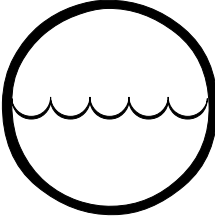
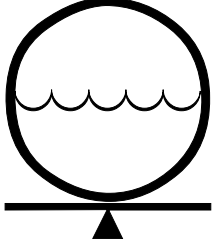
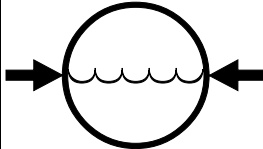
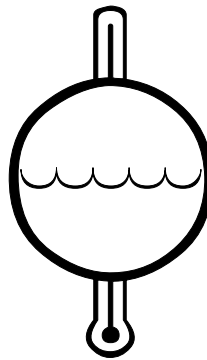
6. Engine oil			
			
1. Oil level	2. Oil refill	3. Oil pressure	4. Oil temperature
			
5. Oil filter			

7. Cooler system			
			
1. Coolant refill	2. Coolant level indicator	3. Coolant pressure	4. Coolant temperature

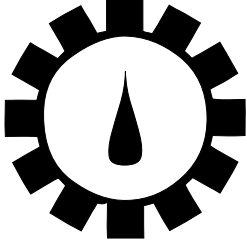
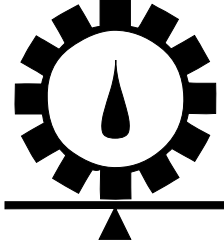
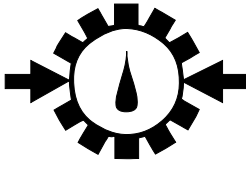
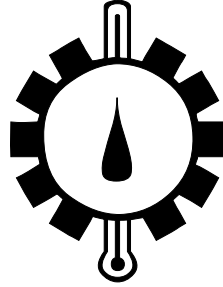
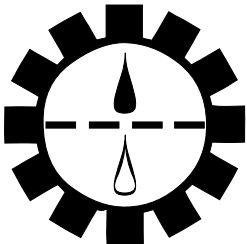
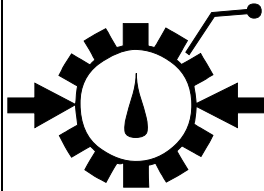
8. Transmission oil

			
1. Oil refill	2. Oil level indicator	3. Oil pressure	4. Oil temperature
			
5. Oil filter	6. Testing point: oil pressure		

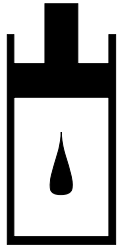
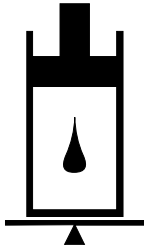
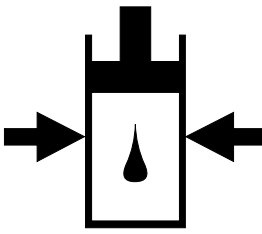
9. Hydraulic oil

			
1. Hydraulic oil refill	2. Hydraulic oil level	3. Hydraulic oil pressure	4. Hydraulic oil temperature

9. Hydraulic oil

<p>5. Hydraulic oil filter</p>	<p>6. Pressure testing</p>	<p>7. Shut-off valve</p>	

10. Air

<p>1. Air intake</p>	<p>2. Air pressure</p>	<p>3. Air filter</p>	

11. Symbols not included in the ISO standard

<p>1. Tensioning of power transmission belt</p>	<p>2. Tightening of nuts and bolts</p>	<p>3. Remove / install transport locking</p>	<p>4. Check / tighten concave bolts</p>

NOISE AND VIBRATION

Noise levels

Noise levels in excess of 85 dBA around the Lokotrack while running are shown in the table below. **Ear protection must be worn in this area.**

Property	Measured value	Standard	Notes
A-weighted sound power level L_{WA}	126 dB	ISO 3746 (1995)	during crushing
A-weighted sound power level L_{WA}	119 dB	ISO 3746 (1995)	during idling
Equivalent A-weighted sound pressure level L_{Aeq}	109 dB	ISO 11202 (1995)	at service platform
Equivalent C-weighted peak sound pressure level L_{Cpeak}	133 dB	ISO 11202 (1995)	at service platform
Equivalent A-weighted sound pressure level L_{Aeq}	96..106 dB	ISO 11202 (1995)	at the distance of 1 m and height of 1,6 m around the LT (maximum level by the crusher)
Equivalent C-weighted peak sound pressure level L_{Cpeak}	120..128 dB	ISO 11202 (1995)	at the distance of 1 m and height of 1,6 m around the LT (maximum level by the crusher)

Vibration

Property	Measured value	Standard	Notes
Weighted r.m.s. acceleration a_w	2,2 m/s^2	ISO/DIS 2631-1 (1994)	vertical direction
Weighted r.m.s. acceleration a_w	0,54 m/s^2	ISO/DIS 2631-1 (1994)	transversal direction
Weighted r.m.s. acceleration a_w	0,32 m/s^2	ISO/DIS 2631-1 (1994)	longitudinal direction
Vibration total value a_v of weighted r.m.s. acceleration	2,3 m/s^2	ISO/DIS 2631-1 (1994)	calculated according to chapter 8.2 of the standard

ADDITIONAL INFORMATION

GUARDS AND PROTECTION DEVICES

- Belt drives are guarded.
- The feed opening to the crusher is guarded.
- Conveyor head and tail drum nip points are guarded.
- Conveyors are equipped with emergency stop cables and safety switches or valves.
- Emergency stop buttons are provided on the remote control box and service platform and in the electrical centre and cabin.

EMERGENCY STOP

If a dangerous situation occurs, pull the nearest emergency stop cable or push an emergency stop button. After pulling an emergency stop cable, the trip switch will remain engaged and a signal light will show. To reset, push the button in the switch. To reset an emergency stop button, pull the red button to its outer position. Before restarting the machine ensure the area is clear around the unit and that no one will be endangered by your action. Start the machine according to the instruction manual.

DISPOSAL OF WASTE

Waste materials, such as oil, battery acids and cleaning fluids etc. must be removed carefully using suitable containers to prevent any hazard to people, animals or environment. The hazardous material must be removed to a suitable waste collection plant for disposal or recycling.

FIRE

The Manufacturer has not provided this machine with a fire extinguisher, and recommends that the user equips the machine with an extinguisher of a type approved by his local authorities. Inflammable materials used in the construction and use of this machine include: diesel and lubricating oils, conveyor belting and skirts, electrical cables and fittings, etc.

STORAGE OF THE MACHINES

The machine must be stored in a dry and covered area.

DISPOSAL OF THE MACHINE

Whenever a machine is taken out of use, being dismantled or disposed of, all hazardous materials, such as oils, battery acids, fuels etc. must be carefully removed first to eliminate any danger to life and the environment. The hazardous materials must be removed to a suitable waste collection plant for disposal or recycling. Dispose of the machine so that there is no danger to life or the environment.

RECYCLING

If the machine is used for recycling, pay attention to the following:

1. Preprocessing of the feed material

Break the feed material small enough and cut the metal bars to 0.5 - 1 metres long depending on the machine. Too long bars may damage the conveyor belt.

2. Feeding the material

Remove the metal objects from the feed, if possible. At least remove the loose metal. The metal objects larger than the crusher setting must not enter the crusher. When removing the metal objects be very careful. Never go to the feeder when the machine is running. Observe the feed material. Never let the uncrushable objects enter the crusher.

3. Removal of the blocking

Be very careful when clearing the blocking. Stop the machine and use safety valve or switch during clearing.

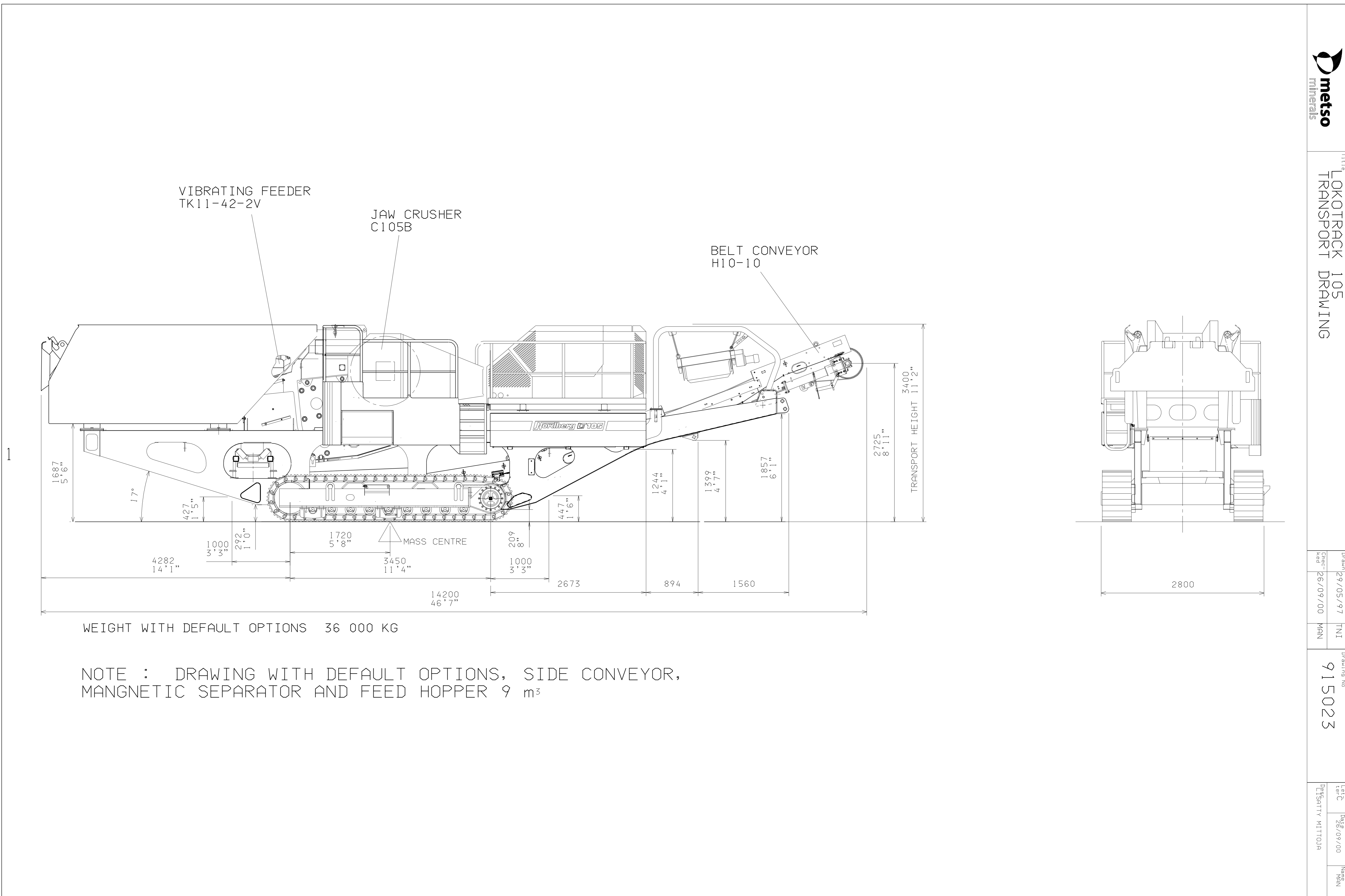

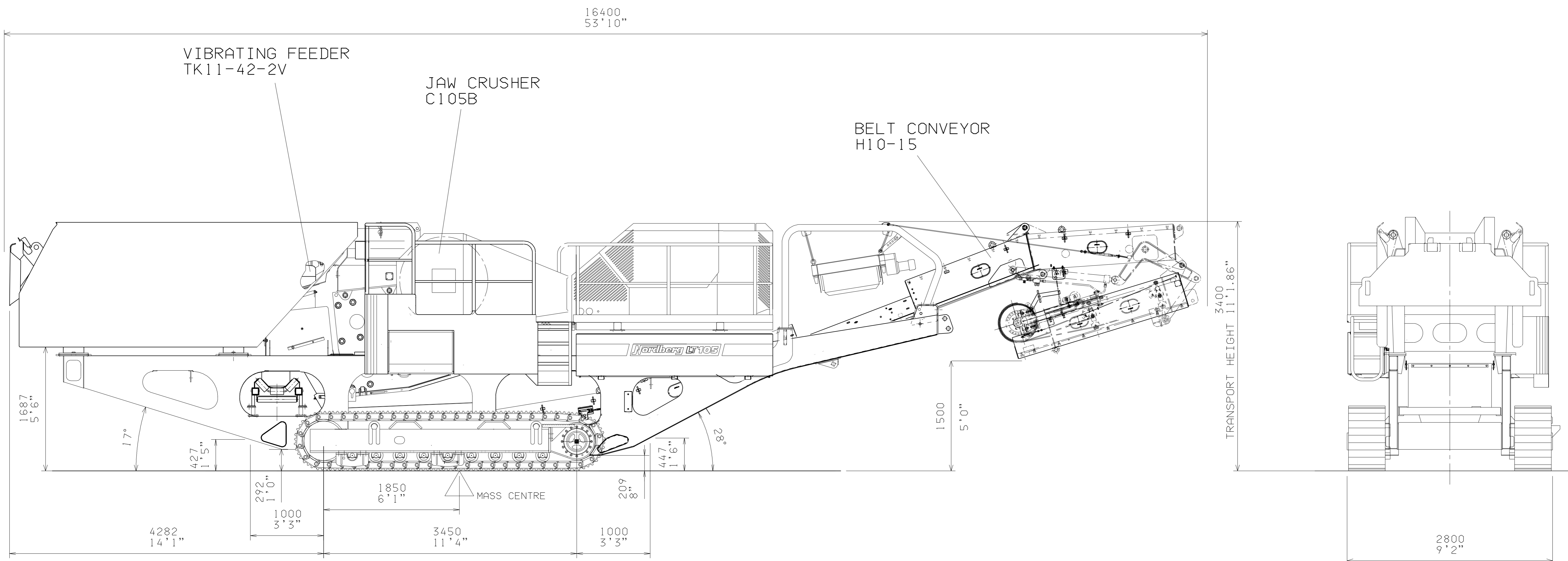

WEIGHT WITH DEFAULT OPTIONS AND BELT CONVEYOR H10-15 37 200 KG

NOTE : DRAWING WITH DEFAULT OPTIONS,
SIDE CONVEYOR, BELT CONVEYOR H10-15
MANGNETIC SEPARATOR AND FEED HOPPER 9 m³

Drawn	29/05/97	TNI
Check	26/09/00	MAN

Drawing No
915023

Author	Date	Name
LIISA-MITTOJA	26/09/00	MAN

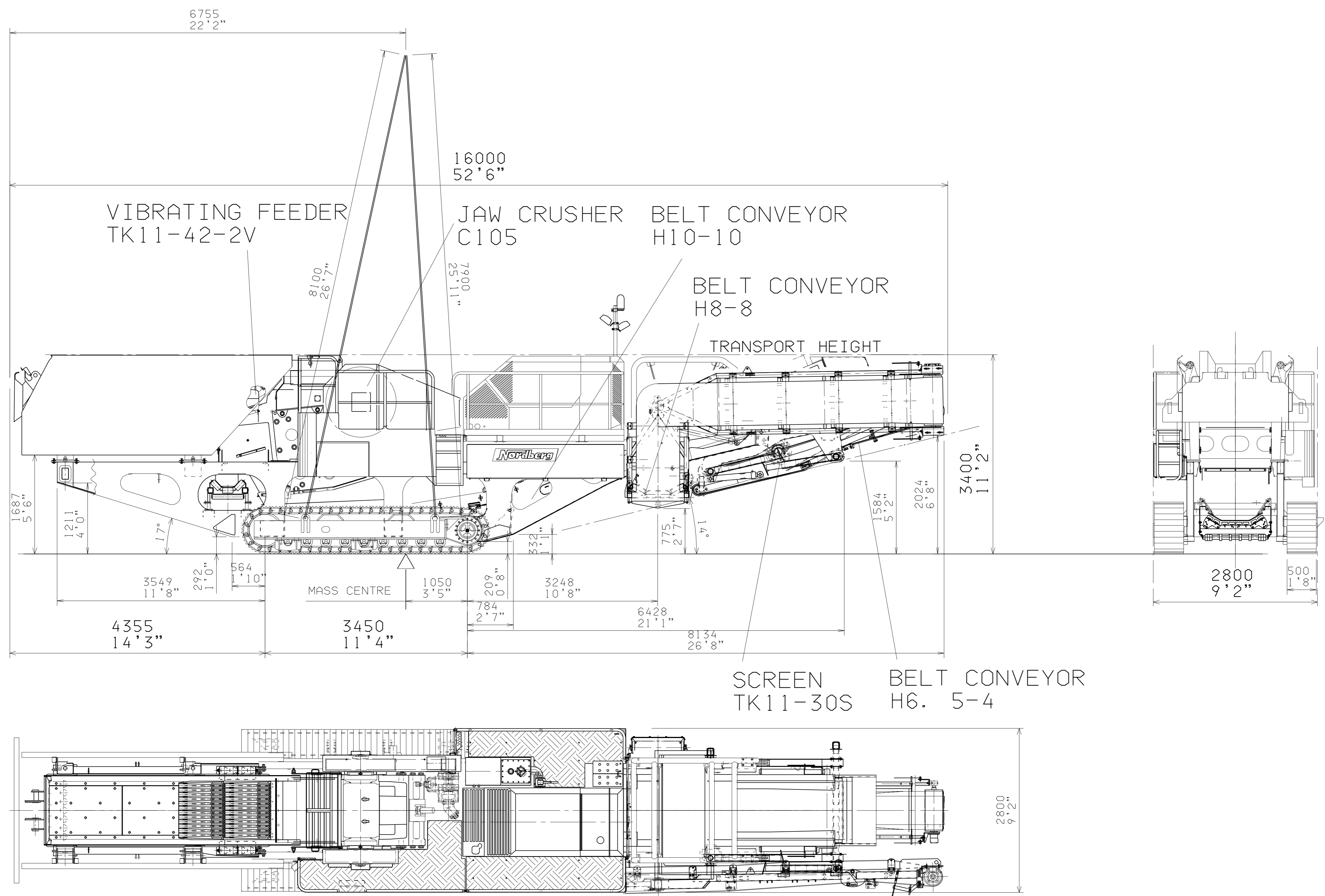

WEIGHT WITH DEFAULT OPTIONS 41600 KG / 91700 lbs

NOTE : DRAWING WITH DEFAULT OPTIONS AND SIDE CONVEYOR,
MAGNETIC SEPARATOR AND FEED HOPPER 9 m³

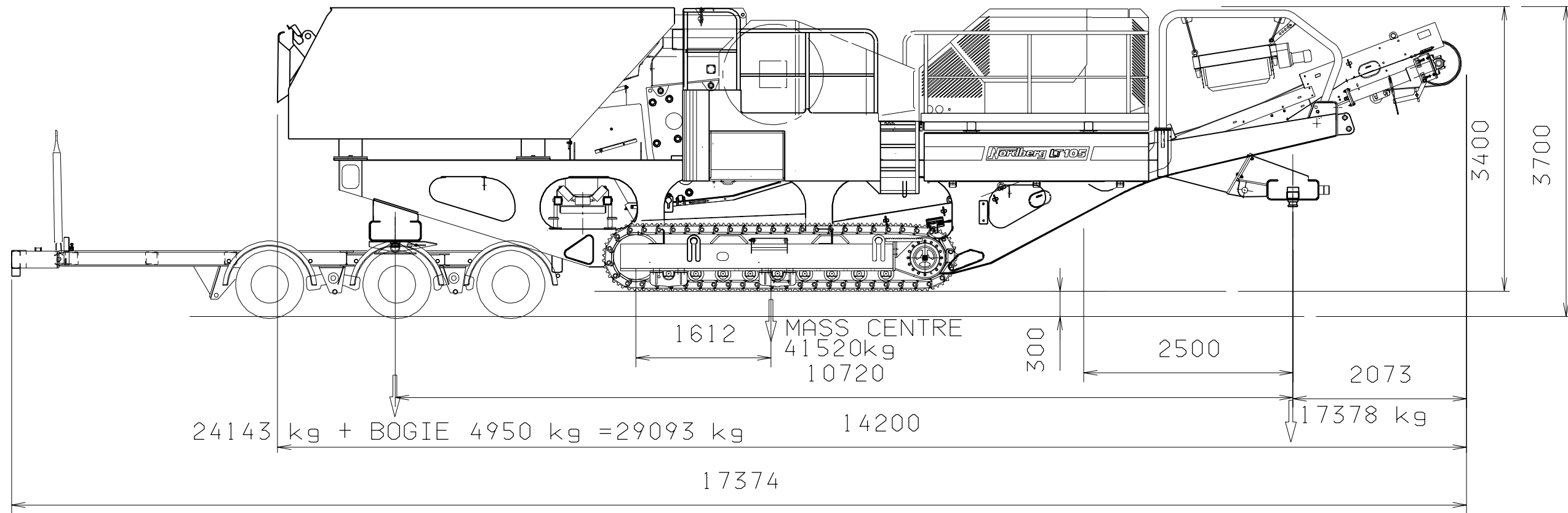

TRANSPORT WIDTH: 2800 mm
 TOTAL WEIGHT 41520 KG + BOGIE 4950 KG

Rev.	No of	Date	Name	Description	Dimensions	Welding symbols	ISO	Surfaces	Re (mm)
0	0				mm				
Used on				Material		Welding symbols		Surfaces	
Material				Drawn	22/03/01	TN	Approved for production	22/03/01	TN
Mass				Checked	22/03/01	TN	for serial production		
Type				Title		Page/Of pages			
0				TRANSPORT DRAWING		1 / 1			
Lok				LOKOTRACK 105				metso minerals	