



## 5 Maintenance

### 5.1 Introduction

Operational readiness and the service life of machines are heavily dependent on maintenance.

It is therefore in the interest of the machine owner to perform the prescribed maintenance work.

Before performing service and maintenance work, always read, understand and follow the instructions given in:

- Chapter 2 “SAFETY INSTRUCTIONS” of this Operator’s Manual
- The Operator’s Manuals of the attachments.

Perform the prescribed inspections and rectify any disorders before putting the machine into service.

Secure open (engine) covers appropriately. Do not open (engine) covers on slopes or in strong wind.

Dirt may be blown away and cause severe injuries when using compressed air. Always wear protective goggles, masks and clothing.

Daily service and maintenance work, and maintenance according to maintenance plan “A” must be performed by a specifically trained operator. All other maintenance work must be performed by trained technicians only.

The maintenance plans indicate when the maintenance work mentioned below must be carried out – see *Maintenance plan (overview)* on page 5-35.

## 5.2 Fuel system

### Refueling

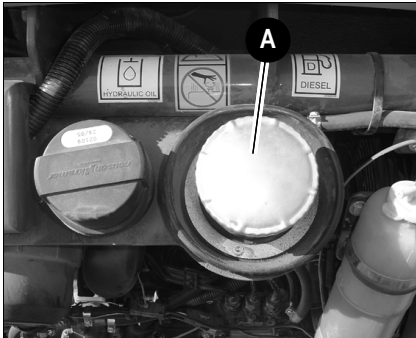


Fig. 102: Fuel filler inlet



### Warning!

Fire and fume inhalation hazards.

- ☞ Do not refuel in closed spaces.
- ☞ Never perform maintenance or repair work on the fuel system in the vicinity of open flames or sparks.
- ☞ Never smoke when working on the fuel system or when refueling.
- ☞ Before refueling, stop the engine and remove the starting key.
- ☞ Wipe up any fuel spills immediately.
- ☞ Remove spilled fuel from the machine components and surfaces before use to reduce the risk of fire.

The fuel fill inlet **A** in Fig. 102 is located in the engine compartment, on the left side in driving direction.



### Environment!

Use a suitable container to collect the fuel as it drains and dispose of it in an environmentally friendly manner!



### Important!

Do not run the fuel tank completely dry. Otherwise, air is drawn into the fuel system. This requires bleeding the fuel system – see *Bleeding the fuel system* on page 5-4.



### Important!

Fill up the tank with the correct fuel type at the end of each working day. This prevents condensation water from forming in the fuel tank over night. Do not fill the tank completely but leave some space for the fuel to expand.

## Draining the fuel

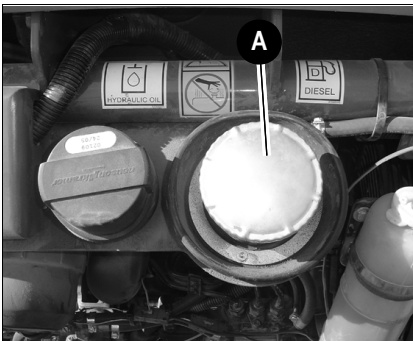


Fig. 103: Fuel tank



### Environment!

Use a suitable container to collect the fuel as it drains and dispose of it in an environmentally friendly manner!

Filler inlet **A** for the fuel tank is located in the engine compartment, on the left in driving direction.

Proceed as follows:

- Open filler inlet **A**.
- Pump out the fuel with a suitable pump.
  - ➡ Collect the fuel in a suitable container.

## Stationary fuel pumps

### General

Only refuel from stationary fuel pumps. Fuel from barrels or cans is usually contaminated. Even the smallest particles of dirt can cause.

- Increased engine wear.
- Malfunctions in the fuel system and.
- Reduced effectiveness of the fuel filters.

### Refueling from barrels

If refueling from barrels cannot be avoided, note the following points (see fig. 104):

- Barrels must neither be rolled nor tilted before refueling.
- Protect the suction pipe opening of the barrel pump with a fine-mesh strainer.
- Immerse the suction pipe into the barrel until there is 15 cm (6") of clearance from the end of the pipe to the bottom of the barrel.
- Only fill the tank using refueling aids (funnels or filler pipes) with integral microfilter.
- Keep all refueling containers clean at all times.

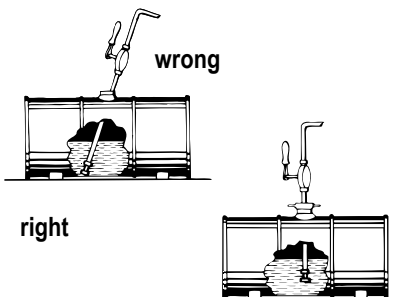


Fig. 104: Refueling from a barrel

Diesel fuel specification

Use only high-grade fuels

Grade	Use
• 2-D ASTM D975 – 94	USA
• 1-D ASTM D975 – 94	
• EN 590 : 96	EU
• ISO 8217 DMX	International
• BS 2869 – A1	England
• BS 2869 – A2	

Bleeding the fuel system



**Warning!**

Fire and burn hazard. Draining fuel may ignite if it comes into contact with hot engine parts or the muffler system. Hot fuel may cause burns.

- ☞ *Stop the engine before draining fuel.*
- ☞ *Always wear protective equipment and safety glasses when working with fuel.*
- ☞ *Never bleed the fuel system if the engine is hot.*

Bleed the fuel system in the following cases:

- After removing and fitting the fuel filter, prefilter or the fuel lines back on again.
- After running the fuel tank empty.
- After running the engine again, after it has been out of service for a longer period of time.

☞ *Bleed the fuel system as follows:*

- Fill the fuel tank.
- Turn the starting key to the first position.
- Wait about 5 minutes while the fuel system bleeds itself automatically.
- Start the engine.

If the engine runs smoothly for a while, and then stops; or if it does not run smoothly:

- Stop the engine.
- Bleed the fuel system again as described above.
- Have this checked by a qualified technician if necessary.

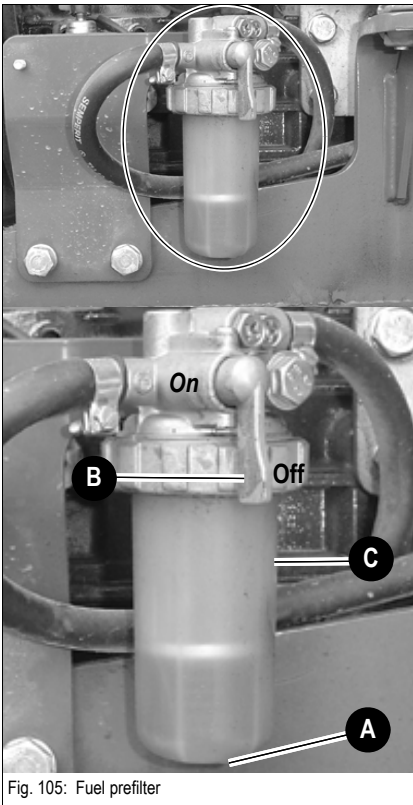
**Fuel prefilter with water separator**

Fig. 105: Fuel prefilter

Interrupt fuel supply as follows:

- ☞ Turn ball-type cock **B** to the **OFF** mark
  - Fuel supply is interrupted
- ☞ Turn ball-type cock **B** to the **ON** mark
  - Fuel supply is open again

Check the fuel prefilter as follows:

- ☞ If the red indicator ring rises to position **C**
- ☞ Unscrew thread **A**
  - The water drains
  - Wait until the indicator ring returns to the bottom of the water separator
- ☞ Screw thread **A** back on again

**Environment!**

Thread **A** is fitted with a hose. Collect the water as it drains with a suitable container and dispose of it in an environmentally friendly manner.

## 5.3 Engine lubrication system

### NOTICE

Possible engine damage or power loss due to improper oil management. If the engine oil level is too low or if an oil change is overdue, this may cause engine damage or a loss of power.

- ☞ Have the oil changed by an authorized service facility.
- ☞ Refer to chapter 5.14 Maintenance plan (overview) on page 5-35.

### Checking the oil level

#### **i** Important!

Check the oil level once a day.  
We recommend checking it before starting the engine. After switching off a warm engine, wait at least 5 minutes before checking.

#### Checking the oil level

☞ Proceed as follows:

- Park the machine on level ground.
- Stop the engine!
- Fold the control lever base up.
- Let the engine cool down.
- Open the engine cover.
- Clean the area around the oil dipstick with a lint-free cloth.
- Oil dipstick **A**:
  - ☞ Pull it out.
  - ☞ Wipe it with a lint-free cloth.
  - ☞ Push it back in as far as possible.
  - ☞ Withdraw it and read off the oil level.

☞ Do not allow the engine oil level to fall below the MIN mark on the dipstick. **A**

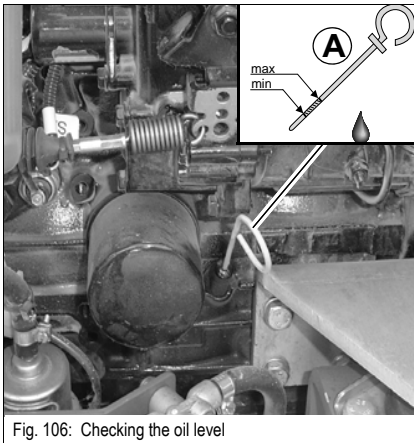


Fig. 106: Checking the oil level



## Draining engine oil



### **Environment!**

Use a suitable container to collect the engine oil as it drains and dispose of it in an environmentally friendly manner!

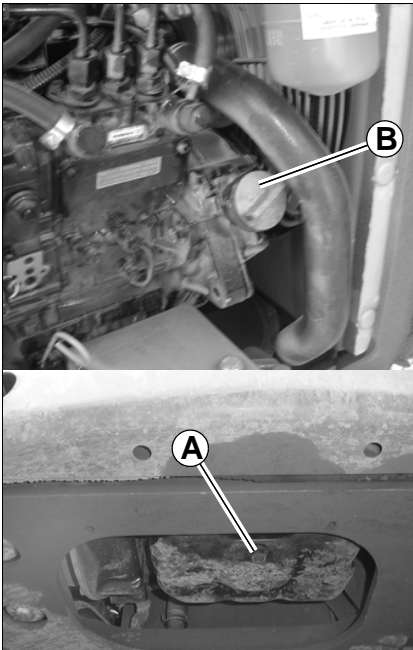


Fig. 107: Oil drain plug

The oil drain plug is located under the engine and is unscrewed through a recess in the chassis at the lower rear of the machine.

### **Draining engine oil**

**ⓘ** Proceed as follows:

- Clean the area around oil filler cap **B** with a lint-free cloth.
- Open filler cap **B**.
- Place a suitable container under oil drain plug **A** to collect the oil as it drains.
- Unscrew oil drain plug **A**.
- ➔ Let the oil drain.
- Then dispose of the oil by an ecologically safe method.
- Screw the oil drain plug back on again.

## Adding engine oil

---

### NOTICE

Possibility of engine damage from too much oil or incorrect engine oil.

- ☞ Do not add engine oil above the MAX mark of oil dipstick 108/A.
  - ☞ Use only the specified engine oil.
- 



### Environment!

Use a suitable container to collect the engine oil as it drains and dispose of it in an environmentally friendly manner!

---

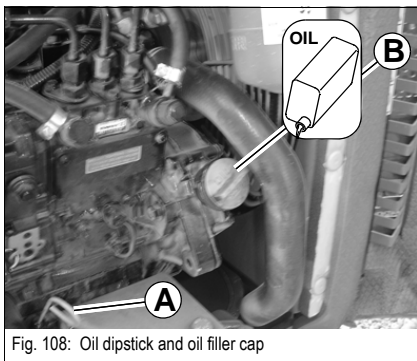


Fig. 108: Oil dipstick and oil filler cap

### Filling up engine oil

☞ Proceed as follows:

- Clean the area around oil filler cap B with a lint-free cloth.
- Open filler cap B.
- Raise oil dipstick A slightly to allow any trapped air to escape.
- Add engine oil.
- Wait about 3 minutes until all the oil has run into the oil sump.
- Check the oil level – see *Checking the oil level* on page 5-6.
- Add oil if necessary and check the oil level again.
- Close filler cap B.
- Push oil dipstick A back in as far as possible.
- Completely remove all oil spills from the engine.





## 5.4 Engine cooling system

The radiator is located in the engine compartment, on the right-hand side of the engine, and cools the diesel engine.

The expansion tank for the coolant is also located in the engine compartment, behind the engine.

### Checking / filling up coolant

---

#### **NOTICE**

Improperly maintaining the cooling system can cause engine damage.

- Dirt on the radiator fins reduces the cooler's heat dissipation capacity.
- Clean the outside of the radiator at regular intervals. Use oil-free compressed air (2 bar max.) to clean. Maintain a certain distance to the radiator to avoid damage to the radiator fins. Refer to the maintenance plans in the appendix for the cleaning intervals.
  - In dusty or dirty work conditions, clean more frequently than indicated in the maintenance plans.
- An insufficient coolant level reduces the heat dissipation capacity and can lead to engine damage:
  - Check the coolant level at regular intervals. Refer to the maintenance plans for the intervals.
  - If coolant must be added frequently, check the cooling system for leaks and/or contact your dealer.
  - Never add cold water/coolant if the engine is warm.
  - After filling the expansion tank, make a test run with the engine and check the coolant level again after switching off the engine.
- The use of the wrong coolant can destroy the engine and the cooler.
  - Add enough antifreeze compound to the coolant – but never more than 50 %. If possible use brand-name antifreeze compounds with anticorrosion additives.
  - Observe the coolant compound table .
  - Do not use cooler cleaning compounds if an antifreeze compound has been added to the coolant – otherwise this causes sludge to form, which can damage the engine.



#### **Environment!**

Use a suitable container to collect the coolant as it drains and dispose of it in an environmentally friendly manner!

---

## Specific safety instructions



### Caution!

Burn hazard. The coolant in the system is hot under normal operating conditions and under about 1 bar (15 psi) pressure.

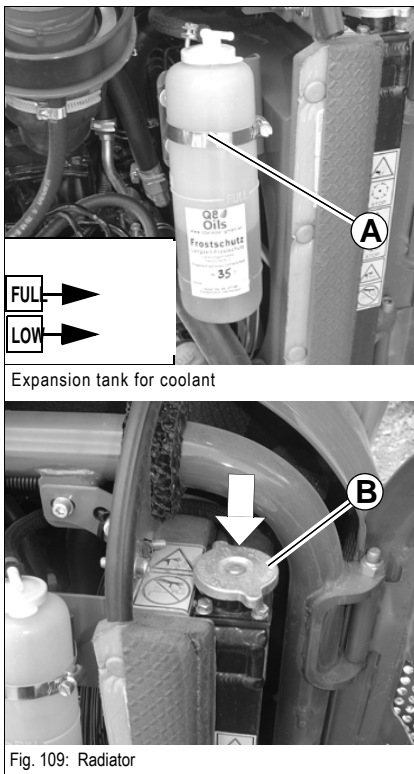
- ⓘ *Never open the coolant tank or drain coolant if the engine is hot.*
- ⓘ *Wait at least 15 minutes after stopping the engine.*
- ⓘ *Wear protective glasses, gloves and clothing.*
- ⓘ *Open filler cap B figure 102 to the first notch and allow the pressure to escape.*
- ⓘ *Do not proceed with checking, maintaining or repairing the cooling system unless the components are comfortable to touch (less than 49°C (120°F)).*



### Caution!

Hazardous material. Coolant mixtures are poisonous and flammable. Contact with skin and eyes should be avoided.

- ⓘ *Wash skin immediately to remove coolant mixture from the skin to avoid irritation.*
- ⓘ *Wash eyes immediately if coolant comes in contact with the eye. Seek medical attention immediately.*
- ⓘ *Store coolant concentrate and mixtures in a secure space to prevent unauthorized contact.*
- ⓘ *Do not store or use coolant or coolant mixtures near open flames including smoking materials.*
- ⓘ *Dispose of used coolant through approved methods for recycling. Do not dispose of coolant or mixtures in sewers, toilets or dumping on the ground.*



### Checking the coolant level

➤ Proceed as follows:

- Park the machine on level ground.
- Switch off the engine!
- Fold up the control lever base.
- Remove the key and carry it with you.
- Let the engine and the coolant cool down.
- Open the engine cover.
- Check the coolant level on the transparent coolant tank **A** and on the radiator **B**.

➤ If the coolant level is below the **LOW** seam or if there is no coolant at the radiator's filler inlet:

➡ Add coolant.



### Important!

Check the coolant level once a day.  
We recommend checking it before starting the engine.

### Filling up coolant

After the engine has cooled down:

- Release pressure in the radiator.
- Carefully open cap **B** to the first notch and allow the pressure to fully escape.
- Open filler cap **B**.
- Add coolant up to the lower edge of the filler inlet (radiator).
- Close filler cap **B**.
- Start the engine and let it warm up for about 5 – 10 minutes.
- Stop the engine.
- Remove the key and carry it with you.
- Let the engine cool down.
- Check the coolant level again.
  - ➡ The coolant level must be between the **LOW** and **FULL** tank seams.
- If necessary, add coolant and repeat the procedure until the coolant level remains constant.



### Important!

Check the antifreeze every year before the cold season sets in.

## 5.5 Air filter

### NOTICE

Possible equipment damage. The filter cartridge will be damaged if it is washed or brushed out.

Keep in mind the following to avoid premature engine wear:

- ☞ Do not clean the filter cartridge.
- ☞ Replace the filter cartridge when the indicator light comes on.
- ☞ Never reuse a damaged filter cartridge.
- ☞ Ensure cleanliness when replacing the filter cartridge.

Replace the air filter element(s) as specified by the maintenance schedule or more often if fouling indicator **B** drops to "Service"!



### Important!

For applications in especially dusty environment, the air filter is fitted with an extra inside filter **C**. Do not clean inside filter **C**.

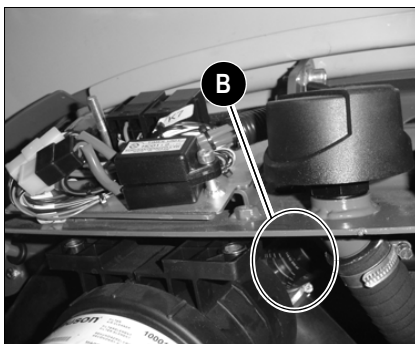


Fig. 110: Indicator for air filter contamination

### NOTICE

Filter cartridge degradation. Filter cartridges degrade prematurely in environments with acidic air, such as acid production facilities, steel and aluminium mills, chemical plants and other nonferrous-metal plants.

- ☞ Replace the filter cartridge after no more than 50 service hours in acidic air.

General instructions for air filter maintenance:

- Store filters in their original packaging and in a dry place!
- Do not knock the filter against other objects as you install it!
- Check air filter attachments, air intake hoses and air filters for damage, and immediately repair or replace if necessary!
- Check the screws at the induction manifold and the clamps for tightness!
- Check the function of the dust valve, replace if necessary!

### Air intake



Fig. 111: Engine air intake

### NOTICE

Possibility of engine damage from water intake.

- ☞ When crossing water, make sure that the engine air intake slits are always above the water level.
- ☞ See chapter "Air intake" on page 5-12.
- ☞ Check the air intake slits once a day for cleanliness before operating the machine.

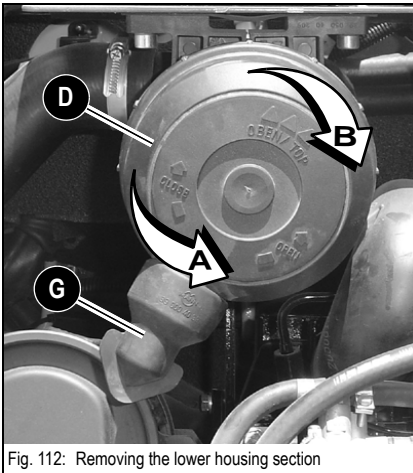
**Replacing the filter**


Fig. 112: Removing the lower housing section

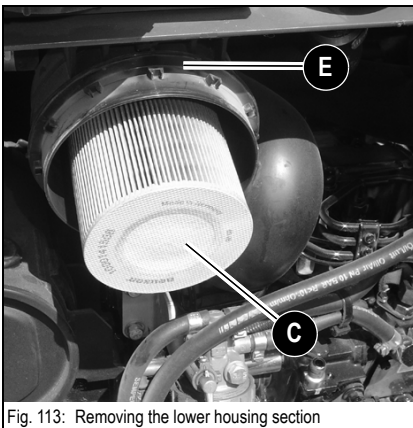


Fig. 113: Removing the lower housing section

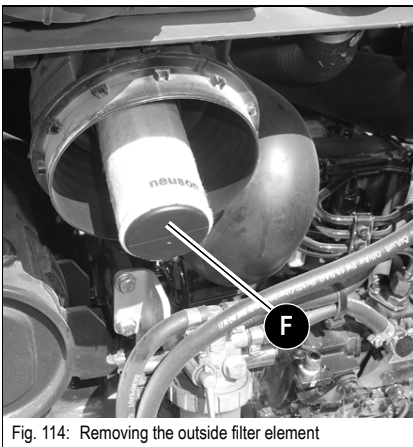


Fig. 114: Removing the outside filter element

- Replace primary filter **C** as follows:

- ☞ Stop the engine.
- ☞ Remove the key and carry it with you.
- ☞ Let the engine cool down.
- ☞ Open the engine cover.
- ☞ Remove dirt and dust from the air filter and the area around the air filter.
- ☞ Rotate the filter end housing **D** (Fig. 112) counter-clockwise (**A**) to remove it..
- ☞ Remove the lower housing section **D**.
- ☞ Carefully remove air filter **C** with slightly turning movements.
- ☞ **Make sure** all dirt (dust) inside the upper and lower housing sections (**E** and **D**), including dust valve **G**, has been removed.
  - ☞ Clean the parts with a clean lint-free cloth, do not use compressed air.
- ☞ Check the air filter cartridges for damage, install only a new or undamaged serviceable primary filter element.
- ☞ Carefully insert the new primary filter element **C** in the upper housing section **E**.
- ☞ Position lower housing section **D** (make sure it is properly seated).
- ☞ Install the filter end housing **D** with the dust ejector valve **G** aimed downward.
  - ☞ To complete the installation, align the notches in the end and body housing and rotate the end housing clockwise (**B**) until the joint is tightly seated.

- Replace secondary filter **F** as follows:

- ☞ Remove the primary filter to access the secondary filter.
  - ☞ Use the previous instructions for removing the primary filter.
- ☞ Carefully extract secondary filter **F**.
  - ☞ Cover the air supply at the end of the filter with a clean lint-free cloth to prevent dust from entering the engine.
- ☞ **Make sure** all dirt (dust) inside the upper and lower housing sections (**E** and **D**), including dust valve **G**, has been removed.
  - ☞ Clean the parts with a clean lint-free cloth, do not use compressed air.
  - ☞ Remove the cloth from the air supply.
- ☞ Check the air filter cartridges for damage, install only a new or undamaged serviceable secondary filter element.
- ☞ Carefully insert the new secondary filter element **F** in the upper housing section **E**.
- ☞ Carefully insert the primary air filter **C** in the upper housing section **E**.
- ☞ Position lower housing section **D** (make sure it is properly seated).
- ☞ Install the filter end housing **D** with the dust ejector valve **G** aimed downward.
  - ☞ To complete the installation, align the notches in the end and body housing and rotate the end housing clockwise (**B**) until the joint is tightly seated.


**Important!**

Make sure the dust ejector valve **G** (Fig. 112) is aimed downward after installation.

## 5.6 V-belt



### Warning!

Crushing, cutting, or burn hazards.

- ⓘ Stop the engine and permit a cool down time. Wait until the engine is comfortable to touch.
- ⓘ Only check, retighten, or replace the V-belt when the engine is stopped.
- ⓘ Disconnect the battery or the battery master switch before proceeding with work on the V-belt.

### NOTICE

Cracked and stretched V-belts cause engine damage.

- ⓘ Have the V-belt replaced by an authorized service facility.

Check the V-belt once a day or every 10 service hours, and retighten if necessary!  
Retighten new V-belts after about 15 minutes of running time.

### Checking V-belt tension

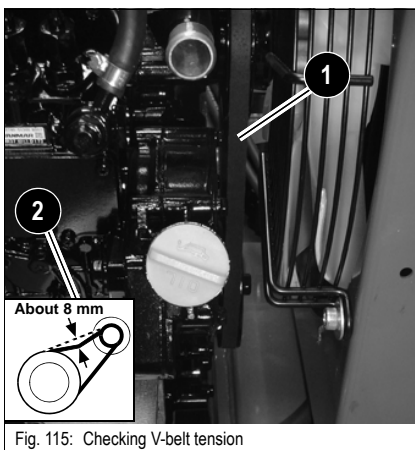


Fig. 115: Checking V-belt tension

- Check as follows:
  - ⓘ Stop the engine.
  - ⓘ Fold up the control lever base.
  - ⓘ Remove the key and carry it with you.
  - ⓘ Open the engine cover.
  - ⓘ Disconnect the battery or the battery master switch.
  - ⓘ Let the engine cool down.
  - ⓘ Carefully check V-belt 1 for damage, cracks or cuts.
  - ⓘ Replace the V-belt if it touches the base of the V-belt groove or the discs of the pulley.
- If the V-belt is damaged:
  - ⓘ Have the V-belt replaced by authorized staff.
  - ⓘ Press with your thumb about 100 N (22.5 lbs) to check the deflection of the V-belt between the crankshaft disc and the fan wheel. A new V-belt should have a deflection of 6 to 8 mm (0.24" to 0.31"), a used V-belt (after about 5 minutes running time) should have a deflection of 7 to 9 mm (0.28" to 0.35") (fig. 115/2).
  - ⓘ Retighten the V-belt if necessary.

**Tightening the V-belt (generator)****NOTICE**

Possible engine damage. Overtightening the V-belt can damage the V-belt, the V-belt guide and the water pump bearing.

- ☞ Avoid contact of oil, grease or similar substances.
- ☞ Check V-belt tension. See "Checking V-belt tension" on page 5-14.

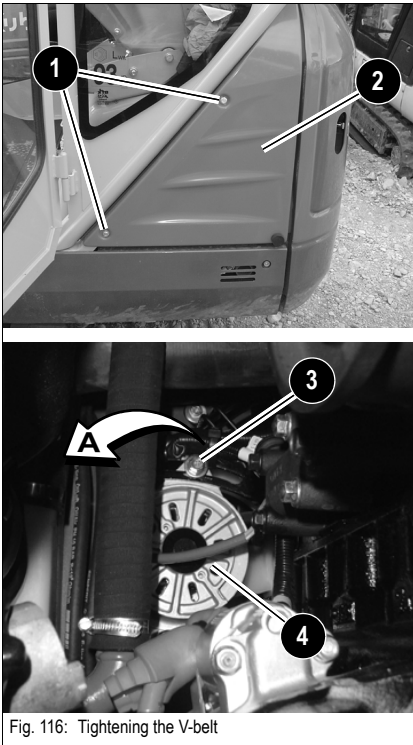


Fig. 116: Tightening the V-belt

- Retighten as follows:
  - ☞ Stop the engine.
  - ☞ Fold up the control lever base.
  - ☞ Remove the key and carry it with you.
  - ☞ Open the engine cover.
  - ☞ Disconnect the battery or the battery master switch.
  - ☞ Let the engine cool down.
  - ☞ Loosen fastening screws 1 of cover 2.
    - ➔ Remove cover 2.
  - ☞ Loosen fastening screw 3 of dynamo 4.
  - ☞ Use a suitable tool to push the generator in the direction of arrow A until reaching the correct V-belt tension – see chapter *Checking V-belt tension* on page 5-14.
  - ☞ Keep the generator in this position, and at the same time retighten fastening screw 3.
  - ☞ Check V-belt tension again and adjust it if necessary.
  - ☞ Tighten fastening screws 1 of cover 2.
  - ☞ Connect the battery or the battery master switch.
  - ☞ Close the engine cover.

## Tightening the V-belt (alternator)

**NOTICE**

Possible engine damage. Overtightening the V-belt can damage the V-belt, the V-belt guide and the water pump bearing.

- ⚠ Avoid contact of oil, grease or similar substances.
- ⚠ Check V-belt tension. See "Checking V-belt tension" on page 5-14.

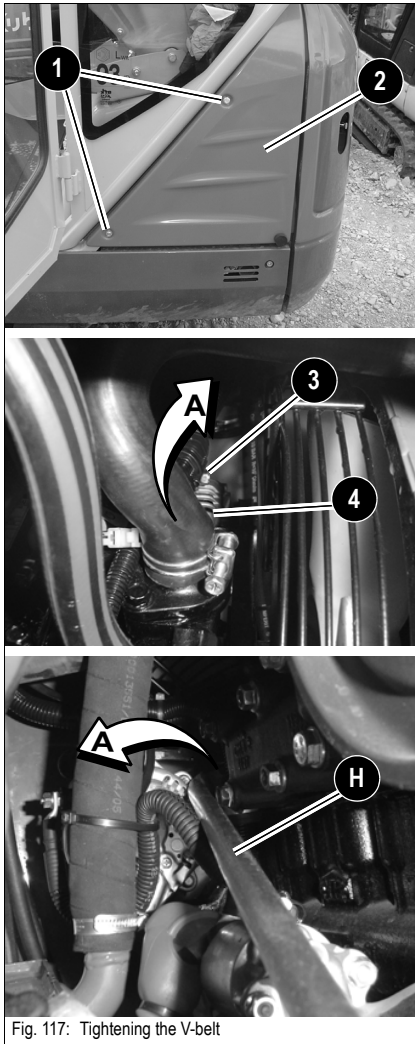


Fig. 117: Tightening the V-belt

- Retighten as follows:
  - ⚠ Stop the engine.
  - ⚠ Fold up the control lever base.
  - ⚠ Remove the key and carry it with you.
  - ⚠ Open the engine cover.
  - ⚠ Disconnect the battery or the battery master switch.
  - ⚠ Let the engine cool down.
  - ⚠ Loosen fastening screws **1** of cover **2**.
    - ➔ Remove cover **2**.
  - ⚠ Loosen fastening screw **3** of alternator **4**.
  - ⚠ Use a suitable tool **H** to push the alternator in the direction of arrow **A** until reaching the correct V-belt tension – see chapter *Checking V-belt tension* on page 5-14.
  - ⚠ Keep the alternator in this position, and at the same time retighten fastening screw **3**.
  - ⚠ Check V-belt tension again and adjust it if necessary.
  - ⚠ Tighten fastening screws **1** of cover **2**.
  - ⚠ Connect the battery or the battery master switch.
  - ⚠ Close the engine cover.



## 5.7 Hydraulic system

### Specific safety instructions



#### Warning!

Pressurized hydraulic oil hazard. Hydraulic oil escaping under high pressure can catch fire, damage property, penetrate the skin and cause severe burns and injuries.

- ☞ Do not operate the machine with leaking or damaged hydraulic system components.
- ☞ Use a piece of cardboard to diagnose the source of hydraulic leaks.
- ☞ Hydraulic oil can be hot and can cause serious burns if contact is made with skin. If contact occurs with hot oil, seek immediate medical attention and treatment for the burn.
- ☞ Wear safety glasses/goggles to avoid eye contact. If oil contacts the eye flush immediately with clean water and seek emergency medical treatment.
- ☞ Seek immediate medical attention if oil penetrates the skin. Oil can cause serious infections.

- Release the pressure in all lines carrying hydraulic oil prior to any maintenance and repair work. To do this:
  - Lower all hydraulically controlled attachments to the ground
  - Move all control levers of the hydraulic control valves several times
- Fold up the control lever base.
- If the hydraulic oil in the sight glass is cloudy, this indicates that water or air has penetrated the hydraulic system. This may cause damage to the hydraulic pump!
- Replace the hose or line if one of the problems mentioned below is detected.
  - ☞ Damaged or leaky hydraulic seals.
  - ☞ Worn or damaged hose covering or uncovered reinforcement branches.
  - ☞ Bulging hose coverings in several positions.
  - ☞ Entangled or crushed movable parts.
  - ☞ Foreign bodies jammed or stuck in protective layers.

---

### NOTICE

Possible equipment damage. Contaminated hydraulic oil, a lack of oil, or the wrong hydraulic oil can severely damage the hydraulic system.

- ☞ Take care to avoid contamination when working.
- ☞ To avoid dirt contamination, use the screened inlet when adding oil.
- ☞ Only use authorized oils of the same type. See chapter 5.13 "Fluids and lubricants" on page 5-33.
- ☞ Always add hydraulic oil before the level gets too low – see chapter Adding oil to the hydraulic reservoir on page 5-20.
- ☞ If the hydraulic system is filled with biodegradable oil, then only use biodegradable oil of the same type for filling. Refer to the label on the hydraulic oil tank.
- ☞ Contact your Wacker Neuson dealer immediately if the hydraulic system filter is contaminated with metal shavings.



---

### Environment!

Collect drained hydraulic oil and biodegradable oil in a suitable container!

Dispose of drained oil and used filters by an ecologically safe method.

Always contact the relevant authorities or commercial establishments in charge of oil disposal before disposing of biodegradable oil.

---

**Checking the hydraulic oil level**

**Warning!**

Pressurized hydraulic oil hazard. Overfilling the hydraulic system with hydraulic oil can lead to high pressures and escaping hydraulic oil. This escaping hydraulic oil can cause severe injury

- ☞ Do not overfill the hydraulic system.
- ☞ Check the hydraulic oil level each time the machine is put into service or once a day.

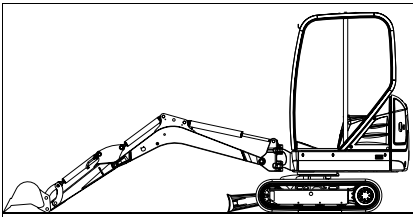


Fig. 118: Parking the excavator

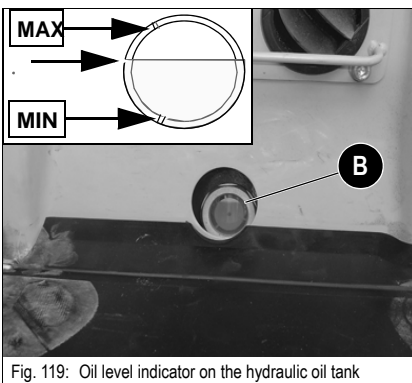


Fig. 119: Oil level indicator on the hydraulic oil tank

- If the attachment is not positioned as shown:
  - ☞ Start the engine and let it run at idling speed.
  - ☞ Retract the bucket and boom hydraulic cylinders, lower the boom and the bucket teeth to the ground.
  - ☞ Extend the stabilizer blade hydraulic cylinder, lower the stabilizer blade to the ground.
  - ☞ Stop the engine again.
- ☞ Proceed as follows:
  - Park the machine on level ground.
  - Retract the bucket and boom hydraulic cylinders, lower the boom and the bucket teeth to the ground.
  - Extend the stabilizer blade hydraulic cylinder, lower the stabilizer blade to the ground.
  - Straighten the boom.
  - Stop the engine.
  - Fold up the control lever base.
  - Sight glass **B** is located at the rear of the machine in the trim.
  - Check the oil level on sight glass **B**.
  - The oil level must be about 1 cm (0.4") over the center, between positions **MIN** and **MAX**, as shown by the arrows in fig. 119.
    - ➡ The **MIN** level is marked by the lower joint.
    - ➡ The **MAX** level is marked by the upper joint.

If the oil level is lower

- Fill up hydraulic oil.

The oil level varies according to the machine's operating temperature:

Machine condition	Temperature	Oil level
• Before putting into service	Between 10 and 30 °C - (50 and 86 °F)	<b>LOW</b> mark
• Normal operation	Between 50 and 90 °C -(122 and 194 °F)	<b>FULL</b> mark


**Important!**

Measure the oil level of the hydraulic system only after the machine reaches its operating temperature.

Adding oil to the hydraulic reservoir



**Warning!**

Personal injury hazard. Escaping oil may cause serious injuries. Removing the hydraulic filter plug can cause pressurized oil to escape. Escaping oil may cause serious injuries.

- ☞ Permit the hydraulic oil to cool to a temperature that is comfortable to the touch.
- ☞ Slightly loosen the breather plug on the hydraulic reservoir enough to relieve pressure in the tank.

Do not fill up the hydraulic oil unless the engine is stopped. Otherwise, hydraulic oil will run out of the filler opening on the hydraulic reservoir.

☞ Fill up as follows:

- Park the machine on level ground.
- Retract the bucket and boom hydraulic cylinders, lower the boom and the bucket teeth to the ground.
- Lower the stabilizer blade to the ground.
- Straighten the boom.
- Stop the engine.
- Fold up the control lever base.
- Let the engine cool down.
- Slowly open breather filter **C**.
- Check the hydraulic oil level on sight glass **B**.
- Add oil if necessary and check again.
- Firmly tighten breather filter **C** again.

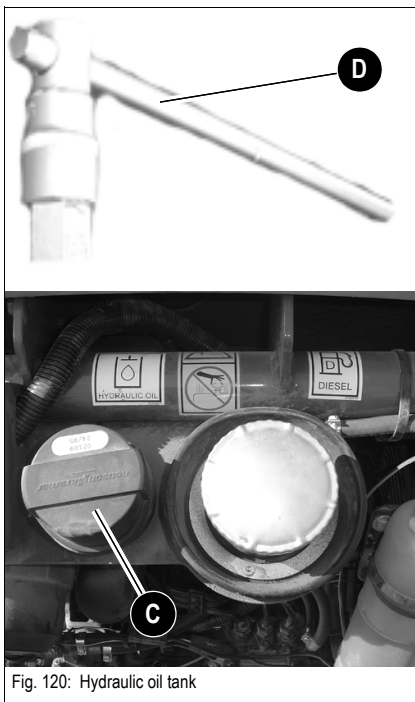


Fig. 120: Hydraulic oil tank

**Important information for the use of biodegradable oil**

- Use only the biodegradable hydraulic fluids which have been tested and approved by Wacker Neuson Linz GmbH. Always contact Wacker Neuson Linz GmbH for the use of other products which have not been recommended. In addition, ask the oil supplier for a written declaration of guarantee. This guarantee is applicable to damage occurring on the hydraulic components, which can be proved to be due to the hydraulic fluid.
- Use only biodegradable oil of the same type for filling. In order to avoid misunderstandings, a label providing clear information is located on the hydraulic oil tank (next to the filler inlet) regarding the type of oil currently used. Replace missing labels!  
The combined use of two different biodegradable oils can affect the quality of one of the oil types. Therefore, make sure the remaining amount of initial hydraulic fluid in the hydraulic system does not exceed 8 % when changing biodegradable oil (manufacturer indications).
- Do not fill with mineral oil – the content of mineral oil should not exceed 2 % in order to avoid foaming problems and to ensure biological degradability.
- When running the machine with biodegradable oil, the same oil and filter replacement intervals are valid as for mineral oil – see [chapter 5.14 Maintenance plan \(overview\)](#) on page 5-35.
- Always have the condensation water in the hydraulic oil tank drained by an authorized service facility before the cold season. The water content may not exceed 0.1 % by weight.
- The instructions in this Operator's Manual concerning environmental protection are also valid for the use of biodegradable oil.
- If additional hydraulic attachments are mounted or operated, use the same type of biodegradable oil for these attachments to avoid mixtures in the hydraulic system.

Subsequent change from mineral oil to biodegradable oil must be performed by an authorized Wacker Neuson service center.

## 5.8 Pilot valve (starting serial number AF01441)

### NOTICE

Possible equipment damage. Dirty oil can damage the piston valves within the pilot valves.

- ☞ Check and if necessary, clean the pilot control filter every 1000 service hours.

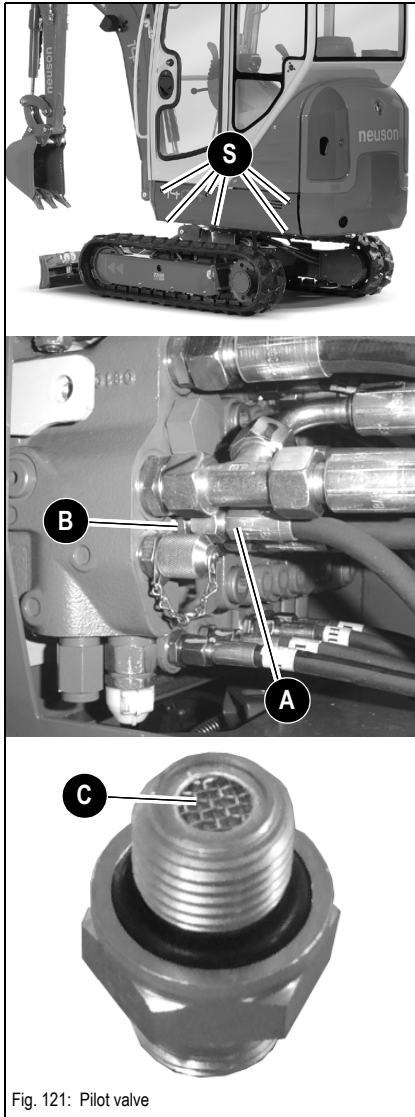


Fig. 121: Pilot valve

Check the pilot valve as follows:

- ☞ Park the machine on level ground.
- ☞ Retract the bucket and boom hydraulic cylinders, lower the boom and the bucket teeth to the ground.
- ☞ Lower the stabilizer blade to the ground.
- ☞ Straighten the boom.
- ☞ Stop the engine.
- ☞ Move the control levers in all directions repeatedly.
- ☞ Stop the engine and remove the starter key.
- ☞ Fold up the control lever base.
- ☞ Let the engine cool down.
- ☞ Slowly open breather filter **C**.
  - ➔ Release the pressure.
- ☞ Install the vacuum pump.
- ☞ Engage the pump before routing hoses.
- ☞ Remove the side panel on the left-hand side of the excavator.
  - ☞ To remove the panel, loosen the 6 fastening screws **S** and remove the trim.
- ☞ Remove pilot control hose **A** from the control valve.
- ☞ Remove pilot control filter **B** from the control valve.
- ☞ Check pilot control filter screen **C** for dirt and clean it if necessary. Replace it by a new filter if it is damaged!
- ☞ Re-assemble in the reverse order.

## Checking hydraulic pressure lines



### Warning!

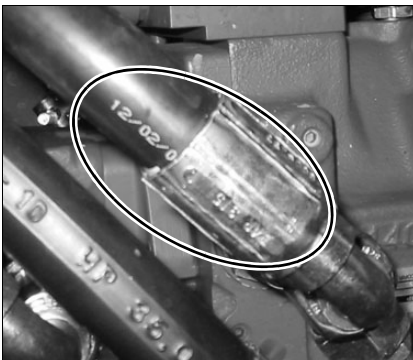
Pressurized hydraulic oil hazard. Hydraulic oil escaping under high pressure can catch fire, damage property, penetrate the skin and cause severe burns and injuries.

- ☞ Do not operate the machine with leaking or damaged hydraulic system components.
- ☞ Use a piece of cardboard to diagnose the source of hydraulic leaks.
- ☞ Hydraulic oil can be hot and can cause serious burns if contact is made with skin. If contact occurs with hot oil, seek immediate medical attention and treatment for the burn.
- ☞ Wear safety glasses/goggles to avoid eye contact. If oil contacts the eye flush immediately with clean water and seek emergency medical treatment.
- ☞ Seek immediate medical attention if oil penetrates the skin. Oil can cause serious infections.
- ☞ Retighten leaking threaded fittings and hose connections only when the system is not under pressure; i.e. release the pressure before working on pressurized lines.
- ☞ Never weld or solder damaged or leaking pressure lines and threaded connections. Replace damaged parts with new ones.
- ☞ Do not check for leaks with an incandescent light or open flame due to explosive fire risk from vaporized oil mist.

- Leaks and damaged pressure lines must be immediately repaired or replaced by a trained technician or your Wacker Neuson dealer. This not only increases the operating safety of your machine but also helps to protect the environment.
- Replace hydraulic hoses every 6 years from the date of manufacture, even if they do not seem to be damaged.

In this respect, we recommend that you observe all the relevant safety standards for hydraulic lines, as well as the safety regulations regarding accident prevention and occupational health and safety in your country.

The article number is marked on the clamping section, and the date of manufacture is indicated on the hose of each hose connection.



## 5.9 Tracks

- Track wear may vary according to work and ground conditions.
  - ☞ We recommend checking track wear and tension once a day.
  - ☞ Park the machine on firm and level ground to check and perform maintenance.

### Checking track tension



#### Warning!

Crushing hazard. Do not work under the machine unless it has been raised and supported properly.

- ☞ *Raising the machine with the stabilizer and working attachments is not an acceptable stable platform to elevate the machine for work underneath the machine!*

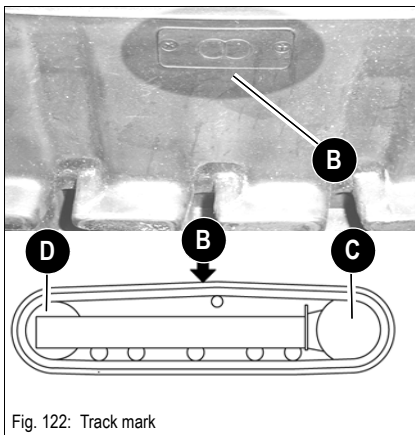


Fig. 122: Track mark

Check track tension as follows:

- The track has a mark **B** as shown in [Fig. 122](#)
- ☞ Place the excavator so that mark **B** of the track is between the drive pinion **C** and the track tension roller **D**

- ☞ Park the machine on firm and level ground.
- ☞ Raise the excavator with the boom and the stick.
  - ☞ Slowly and carefully actuate the control levers.
- ☞ Stop the engine.
- ☞ Remove the key and carry it with you.
- ☞ Fold up the control lever base.
- ☞ Support the raised machine with blocks and cribbing adequate to provide a stable position while working on the track system.
- Standard play between the sliding block's shoulder and the contact area of the second support roller of the drive pinion is 20 – 25 mm (0.78 in. - 0.98 in.).
  - ☞ Set the tension as follows if it is not in accordance with the rated value.

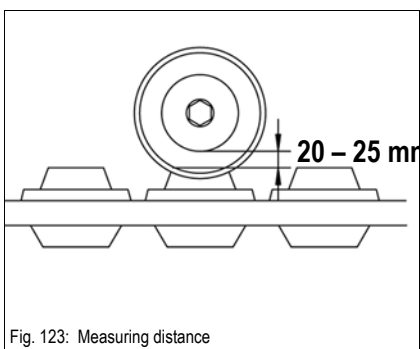


Fig. 123: Measuring distance





**Adjusting the track tension**



**Caution!**

Projectile hazard. The grease fitting for track adjustment is subject to high pressure. The grease fitting can become a projectile if pressure caused by track tension is not properly relieved.

- ☞ Do not remove the grease fitting.
- ☞ Wear safety goggles, gloves and protective clothing to reduce skin exposure to grease. Wipe grease from skin and seek immediate attention if grease contacts eyes.
- ☞ When relieving the pressure in the track tension system, do not turn the grease fitting farther than one counter-clockwise turn.
- ☞ Do not loosen any part of the track tension system until the pressure has been released from the track tension system.
- ☞ Keep your face away from the lubricating valve connection.
- ☞ Do not use auxiliary force on the track or idler in an effort to force grease from the loosened fitting. Contact your Wacker Neuson dealer and wait for a qualified technician to determine the problem and how to solve it.

**NOTICE**

Possibility of equipment damage. Excessive tension of the tracks causes severe damage to the ram and the track.

- ☞ Tighten the tracks only up to the prescribed measuring distance.

**Tightening the tracks**

- ☞ Inject grease with the gun **X** through lubricating valve **A**
- ☞ Check the tension is correct by starting the engine, letting it run at idling speed and slowly moving the machine forwards and reverse and switching it off again
- ☞ Check the tension of the track tracks again.
  - ➔ If it is not correct:
    - ☞ Adjust again
- ☞ Contact your Wacker Neuson dealer if the procedure for tightening the tracks does not correct the track tension.

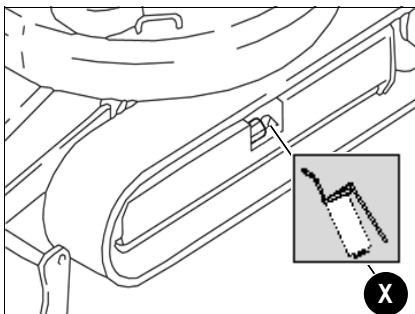


Fig. 124: Tightening the tracks

**Reducing tension**

- Draining grease in a way different from the one described below is very dangerous. Also bear in mind the safety instructions on this page
- ☞ Place a suitable container underneath to collect the grease
- ☞ Slowly open the lubricating valve **A** by 1 turn to allow the grease to flow out.
  - ➔ The grease flows out of the groove of the lubricating valve
- ☞ Retighten the lubricating valve **A**
- ☞ Check the tension is correct by starting the engine, letting it run at idling speed and slowly moving the machine forwards and reverse and switching it off again
- ☞ Check the tension of the track tracks again
  - ➔ If it is not correct:
    - ☞ Adjust again

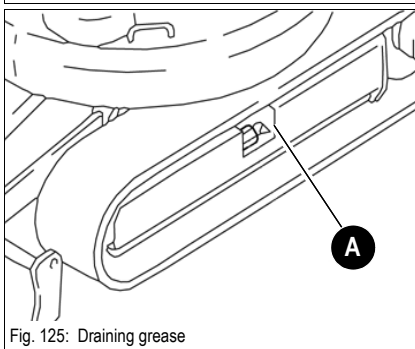


Fig. 125: Draining grease



**Environment!**

Use a suitable container to collect the grease as it flows out and dispose of it in an environmentally friendly manner.

## 5.10 Track propulsion final drive



### Warning!

Burn hazard. The traveling drive and the oil inside can remain hot and under pressure even after the engine has been switched off. This hot oil may leak from the traveling drive.

- ☞ Wait until the engine has cooled down before performing maintenance work.

### Checking the oil level and filling up oil

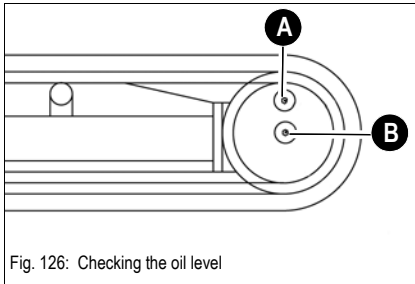


Fig. 126: Checking the oil level

- ☞ Park the machine on firm and level ground.
- ☞ Place the machine so that filler plug **A** is at the top.
- ☞ Stop the engine.
- ☞ Let the engine cool down.
- ☞ Fold the control lever base up.
- ☞ Loosen and remove screws **A** and **B** with a suitable tool.
- ☞ A small quantity of oil must flow out of opening **B**.
- ➔ If the oil does not flow out of opening **B**, fill up oil:
  - ☞ Add oil at opening **A**,
  - ➔ until a small quantity of oil flows out of opening **B**.
- ☞ Screw screws **A** and **B** back in again.
- ☞ Move the machine a few meters or feet.
- ☞ Check the oil level again.
  - ➔ If the oil level is not correct:
  - ☞ Repeat the procedure.

### Draining oil

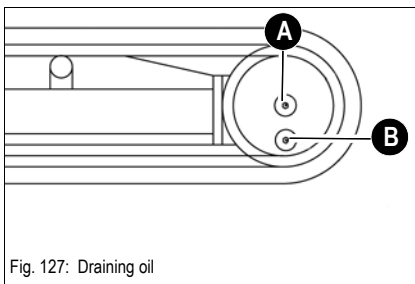


Fig. 127: Draining oil

- ☞ Park the machine on firm and level ground.
- ☞ Place the machine so that filler plug **B** is at the bottom.
- ☞ Switch off the engine.
- ☞ Let the engine cool down.
- ☞ Fold the control lever base up.
- ☞ Loosen and remove screws **A** and **B** with a suitable tool.
  - ➔ The oil now flows out of opening **B**.
- ☞ Use a suitable container to collect the oil as it drains.



### Environment!

Collect the oil with a suitable container and dispose of it in an environmentally friendly manner.

### Maintenance of attachments



### Important!

Correct maintenance and service is absolutely necessary for smooth and continuous operation, and for an increased service life of the attachments. Please observe the lubrication and maintenance instructions in the attachments' Operator's Manuals.



## 5.11 Electric system

### Specific safety instructions



#### **Warning!**

Batteries can explode or cause chemical burns. A battery contains sulfuric acid and emits explosive gases when heavily discharged.

- ☞ Do not smoke or use an open flame near the battery.
- ☞ Do not handle the battery recklessly, causing acid to leak or spill.
- ☞ Do not add circuits or electrical accessories that exceed the system capacity.
- ☞ Do not connect a circuit without a correctly-rated fuse or circuit breaker.

#### **NOTICE**

Possible equipment damage from improper battery connections.

- ☞ Use only 12 V power sources. Higher voltages will damage the electric components.
- ☞ When connecting the battery leads, make sure the poles +/– are not reversed, otherwise sensitive electric components will be damaged.
- ☞ Do not interrupt voltage-carrying circuits at the battery terminals because of the risk of sparking.
- ☞ To prevent short circuits, never place tools or other conductive articles on the battery.
- ☞ Disconnect the negative (–) battery terminal from the battery before starting repair work on the electric system.



#### **Important!**

Dispose of used batteries properly.

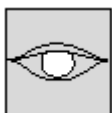
### Service and maintenance work at regular intervals



#### **Before operating the machine**

☞ Check every time before operating the machine:

- Is the light system OK?
- Is the signalling and warning system OK?



#### **Every week**

☞ Check once a week:

- Electric fuses
- Cable and ground connections
- Batter charge condition – see *Battery* on page 5-29
- Condition of battery terminals



## Instructions concerning specific components

### Cables, bulbs and fuses

#### Always observe the following instructions:

- Defective components of the electric system must always be replaced by a trained technician.
- When performing maintenance work on the electric system, pay particular attention to ensuring good contact in leads and fuses.
- Blown fuses indicate overloading or short circuits. The electric system must therefore be checked before installing the new fuse.
- Only use fuses with the specified load capacity (amperage).

## Alternator

#### Always observe the following instructions:

- Only test run the engine with the battery connected.
- When connecting the battery, make sure the poles (+/-) are not reversed.
- Always disconnect the battery before performing welding work or connecting a quick battery charger.
- Replace defective charge indicator lights immediately.  
– see [chapter Indicator lights and warning lights: overview](#) on page 3-10

**Battery****Warning!**

Battery acid hazard. The battery contains highly caustic sulphuric acid. This acid must not be allowed to come into contact with the skin, the eyes, clothing, or the machine.

- ☞ *When recharging and/or working near the battery, always wear goggles and protective clothing with long sleeves.*
- ☞ *If acid is spilled, thoroughly rinse affected skin immediately with clean water and seek medical attention immediately.*

**Warning!**

Battery explosion hazard. Lead acid batteries can generate a potentially explosive hydrogen and oxygen mixture. Batteries can explode or rupture during jump starting, particularly if the electrolyte is low or has been frozen.

- ☞ *Avoid open flames and sparks in the vicinity of the battery. Do not smoke.*
- ☞ *Before jump-starting, take the battery to the dealer for appraisal by a qualified technician.*
- ☞ *Replace a dead battery with a new one equivalent to the original.*
- ☞ *Always disconnect the negative terminal (-) from the battery before starting repair work on the electric system.*

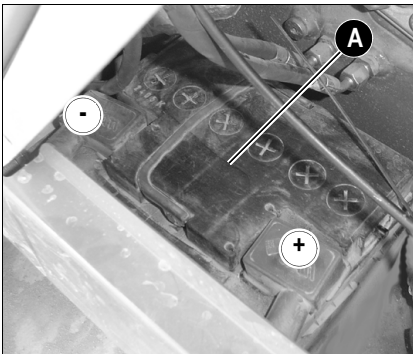


Fig. 128: Battery

Battery **A** is located behind the rear left side trim. The battery is "maintenance-free". However have the battery checked at regular intervals to make sure the electrolyte level is between the MIN and MAX marks.

Checking the battery requires it to be removed and must be performed by an authorized workshop.

Always follow the specific battery safety instructions!

**Important!**

Do not disconnect the battery while the engine is running.



## 5.12 General maintenance work

### Cleaning

Cleaning the machine is divided into 3 separate areas:

- Inside the cab
- Exterior of the machine
- Engine compartment

To avoid personal injury and damage to the machine, always follow the recommendations for cleaning the machine.

### General instructions for all areas of the machine

#### When using washing solvents

- Ensure adequate room ventilation.
- Wear suitable protective clothing.
- Do not use flammable liquids, such as petrol or diesel.

#### When using compressed air

- Work carefully.
- Wear goggles and protective clothing.
- Do not aim the compressed air at the skin or at other people.
- Do not use compressed air for cleaning your clothing.

#### When using a high-pressure cleaner or steam jet

- Electric components and damping materials must be covered and not directly exposed to the jet.
- Cover the vent filter on the hydraulic oil tank and the filler caps for fuel, hydraulic oil etc.
- Protect the following components from moisture:
  - Engine
  - Electric components such as the alternator etc.
  - Control devices and seals.
  - Air intake filters etc.

#### When using volatile and easily flammable anticorrosion agents and sprays:

- Ensure adequate room ventilation.
- Do not use unprotected lights or open flames.
- Do not smoke!



**Inside the cab**

---

**NOTICE**

Possible equipment damage from high pressure cleaning. Water under high pressure may penetrate the electric system and cause short circuits, damage seals and disable the controls.

☞ *Never use high-pressure cleaners, steam jets or high-pressure water to clean inside the cab.*

---

We recommend using the following aids to clean the cab:

- Broom
- Vacuum cleaner
- Damp cloth
- Bristle brush
- Water with mild soap solution

**Cleaning the seat belt:**

- Clean the seat belt (which remains fitted in the machine) only with a mild soap solution; do not use chemical agents as they may destroy the fabric!

**Exterior of the machine**

The following articles are generally suitable:

- High-pressure cleaner
- Steam jet

**Engine compartment**



**Caution!**

Cutting, crushing, or burn hazards.

☞ *Stop the engine before cleaning.*

---

**NOTICE**

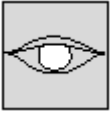
Possibility of sensor damage. Water or steam jet cleaners can penetraet sensitive electrical components, leading to sensor failure and possible engine damage.

☞ *Allow the machine to cool completely before cleaning the engine with a water or steam jet.*

☞ *Do not point the jet directly at electric sensors such as the oil pressure switch.*

---

### Threaded connections and fasteners



All screw connections must be checked regularly for tightness, even if they are not listed in the maintenance schedules.

- ☞ *Engine fastening screws.*
- ☞ *Fastening screws on the hydraulic system.*
- ☞ *Line, bucket teeth and pin attachments on the attachment.*

Retighten loose connections immediately. Contact an authorized workshop if necessary.

### Pivots and hinges



All mechanical pivot points on the machine (e.g. door hinges, joints) and fittings (e.g. door arresters) must be lubricated regularly, even if they are not listed in the lubrication plan.



**5.13 Fluids and lubricants**

Component / application	Engine / machine fluid	Specification	Season / temperature	Capacities <sup>1</sup>
Diesel engine	Engine oil	API CD, CF, CF-4, CI-4	-15 °C(5°F) +45 °C(113°F)	2.5 l (0.6 gal)
		ACEA: E3, E4, E5 (SAE 10W40) <sup>2</sup>		
Travelling drive	Gearbox oil <sup>3</sup>	Q8 T 55, SAE85W-90	Year-round	About 0.4 l (0.1gal) each
		FINA PONTONIC GLS, SAE85W-90		
Hydraulic oil tank	Hydraulic oil	HVLP46 <sup>4</sup> 200 Hydraulic	Year-round	35 l (9.24 gal)
	Biodegradable oil <sup>5</sup>	PANOLIN HLP Synth 46		
		FINA BIOHYDRAN SE 46		
		BP BIOHYD SE-46 404 Biodegradeable Hydraulic 32/46		
Grease	Roller and friction bearings <sup>6</sup>	FINA Energrease L21M Mobilgrease CM-P	Year-round	As required
	Open gear <sup>7</sup> (live ring gears)	BP Energrease MP-MG2	Year-round	As required
Grease nipples	Multipurpose grease <sup>8</sup>	FINA Energrease L21M Mobilgrease CM-P	Year-round	As required
Battery terminals	Acid-proof grease <sup>9</sup>	FINA Marson L2 Mobilux EP2	Year-round	As required
Fuel tank	Diesel fuel	2-D ASTM D975 – 94 (USA)	Depending on outside temperatures Summer or winter diesel fuel	24 l (6.34 gal)
		1-D ASTM D975 – 94 (USA)		
		EN 590 : 96 (EU)		
		ISO 8217 DMX (International)		
		BS 2869 – A1 (GB)		
		BS 2869 – A2 (GB)		
Radiator	Coolant	Soft water + antifreeze ASTM D4985	Year-round	4 l (1.05 gal)
		Distilled water + antifreeze ASTM D4985		
Washer system	Cleaning agent	Water + antifreeze	Year-round	1.2 l (0.3 gal)

1. The capacities indicated are approximative values; the oil level check alone is relevant for the correct oil level  
Capacities indicated are no system fills
2. According to DIN 51511
3. Hypoid gearbox oil based on basic mineral oil (SAE85W-90 according to DIN 51502), (API GL-4, GL5)
4. According to DIN 51524 section 3
5. Hydraulic ester oils (HEES)
6. KF2K-25 according to DIN 51502 multipurpose lithium grease with MoS<sup>2</sup> additive
7. KP2N-20 according to DIN 51502 EP multipurpose calcium sulphonate complex grease
8. KF2K-25 according to DIN 51502 multipurpose lithium grease with MoS<sup>2</sup> additive
9. Standard acid-proof grease



Oil grades for the diesel engine, depending on temperature

Engine oil grade	Ambient temperature (C°)														
	°C	-20	-15	-10	-5	0	5	10	15	20	25	30	35	40	
	SAE 10W														
					SAE 20W										
	SAE 10W-30														
	SAE 10W-40														
	API: CH4, CE/SJ ACEA: A3, B3, E3	SAE 15W-40													
						SAE 20									
								SAE 30							
											SAE 40				
	°F	-4	5	14	23	32	41	50	59	68	77	86	95	104	

**Additional oil change and filter replacement (hydraulics)**

**NOTICE**

An additional oil change and filter replacement may be required depending on how the machine is used. Failure to observe these replacement intervals can cause damage to hydraulic components.

☞ Observe the following intervals:

Application	Hydraulic oil	Hydraulic oil filter insert
Normal work (excavation work)	Every 1000 s/h	Replace the first time after 50 s/h, then every 500 s/h
Percentage of hammer work	20 %	300 s/h
	40 %	
	60 %	100 s/h
	Over 80 %	



**Important!**

Please refer to the maintenance plan on page 5-35 for additional maintenance work.





## 5.14 Maintenance plan (overview)

### Work description

For service and maintenance work on the attachment, please refer to the operation and maintenance manual of the attachment manufacturer as well.

### Maintenance plan/service hours (s/h)

	Maintenance work (once a day)	Every 50 s/h	Every 500 s/h	Every 1000 s/h once a year	Customer	Authorized workshop
<b>Fluid and filter changes (  ):</b>						
Perform the following oil and filter changes (check oil levels after test run):						
• Engine oil <sup>1</sup>		●	●			●
• Engine oil filter <sup>2</sup>		●	●			●
• Fuel filter <sup>3</sup>		●	●			●
• Air filter element if fouling indicator is at "Service"					●	
• Coolant				●		●
• Hydraulic oil filter insert <sup>4</sup>		●	●			●
• Hydraulic oil <sup>5</sup>			●	●		●
• Hydraulic oil tank breather filter				●		●
• Gearbox oil <sup>6</sup>		●		●		●
<b>Inspection work (  ):</b>						
Check the following material. Refill if necessary:						
• Engine oil	●				●	
• Engine coolant	●				●	
• Hydraulic oil	●				●	
• Gearbox oil		●				●
Clean water ducts <sup>7</sup>				●		●
Check engine/hydraulic oil radiator and air conditioning for contamination. Clean if necessary	●				●	
Check cooling systems, heating and hoses for leakages and pressure (visual check)	●				●	
Check the pilot control filter on the safety valve for dirt, clean it if necessary				●		
Replace the cab filter of the heating system (option)			●			●
Air filter (damage)	●				●	
Prefilter with water separator: drain water	●				●	

## 5.14 Maintenance plan (overview)

### Work description

For service and maintenance work on the attachment, please refer to the operation and maintenance manual of the attachment manufacturer as well.

- Clean

Check V-belt condition and tension

Check muffler system for damage and condition

Check valve tip clearance. Adjust if necessary

Clean and adjust the fuel injection pump<sup>8</sup>

Check and adjust the injection pressure of the injection nozzles, clean the injection needles/nozzles

Check and adjust injection time<sup>9</sup>

Empty diesel fuel tank

Check battery electrolyte. Fill up with distilled water if necessary

Check alternator, starter and electric connections, bearing play and function

Check preheating system and electric connections

Pressure check of primary pressure limiting valves<sup>10</sup>

Check tracks for cracks and cuts

Check track tension. Retighten if necessary

Check bearing play of tread rollers, track carrier rollers, front idlers

Check piston rods for damage

Check screws for tightness<sup>8</sup>

Check pin lock

Check line fixtures

Check indicator and indicator lights for correct function

Couplings, dirt pile-up on hydraulic system dust caps if necessary

Check insulating mats in the engine compartment for damage/condition

Check labels and Operator's Manual for completeness and condition

### Maintenance plan/service hours (s/h)

	Maintenance plan/service hours (s/h)					
	Maintenance work (once a day)	Every 50 s/h	Every 500 s/h	Every 1000 s/h once a year	Customer	Authorized workshop
• Clean			●		●	
Check V-belt condition and tension	●				●	
Check muffler system for damage and condition	●				●	
Check valve tip clearance. Adjust if necessary				●		●
Clean and adjust the fuel injection pump <sup>8</sup>				●		●
Check and adjust the injection pressure of the injection nozzles, clean the injection needles/nozzles				●		●
Check and adjust injection time <sup>9</sup>				●		●
Empty diesel fuel tank			●			●
Check battery electrolyte. Fill up with distilled water if necessary		●	●		●	
Check alternator, starter and electric connections, bearing play and function			●			●
Check preheating system and electric connections			●			●
Pressure check of primary pressure limiting valves <sup>10</sup>		●	●			●
Check tracks for cracks and cuts	●				●	
Check track tension. Retighten if necessary	●				●	
Check bearing play of tread rollers, track carrier rollers, front idlers			●			●
Check piston rods for damage	●				●	
Check screws for tightness <sup>8</sup>		●	●			●
Check pin lock	●				●	
Check line fixtures	●				●	
Check indicator and indicator lights for correct function		●	●			●
Couplings, dirt pile-up on hydraulic system dust caps if necessary	●				●	
Check insulating mats in the engine compartment for damage/condition		●			●	
Check labels and Operator's Manual for completeness and condition		●			●	



## 5.14 Maintenance plan (overview)

### Work description

For service and maintenance work on the attachment, please refer to the operation and maintenance manual of the attachment manufacturer as well.

### Lubrication service ( ):

Lubricate the following assemblies/components: – see *Maintenance label* on page 5-38

	Maintenance work (once a day)	Every 50 s/h	Every 500 s/h	Every 1000 s/h once a year	Customer	Authorized workshop
• Stabilizer blade	●				●	
• Swivelling console	●				●	
• Boom	●				●	
• Stick	●				●	
• Attachments	●				●	
• Grease strip on chassis – see <i>Maintenance label</i> on page 5-38	●				●	

### Functional check ( ):

Check the function of the following assemblies/components. Rectify if necessary:

• Lights, signalling system, acoustic warning system <sup>11</sup>		●	●			●
• Heating function <sup>10</sup>		●	●			●

### Leakage check ( ):

Check for tightness, leaks and chafing: pipes, flexible lines and screw connections of the following assemblies and components. Rectify if necessary:

• Visual check	●				●	
☞ Engine, hydraulic system and hydraulic components	●				●	
☞ Cooling circuit	●				●	
☞ Travelling drive	●				●	

1. Drain engine oil the first time after 50 s/h, then every 250 s/h
2. Replace the engine oil filter the first time after 50 s/h, then every 250 s/h
3. Replace the fuel filter the first time after 50 s/h, then every 500 s/h
4. Replace the hydraulic oil filter insert the first time after 50 s/h, then every 500 s/h
5. Drain the hydraulic oil the first time after 500 s/h, then every 1000 s/h
6. Drain the gearbox oil the first time after 50 s/h, then every 1000 s/h
7. Clean the water ducts every other 1000 s/h servicing
8. Clean and adjust the fuel injection pump every other 1000 s/h servicing
9. Check and adjust injection time every other 1000 s/h servicing
10. First check after 50 s/h, then every 500 s/h
11. Check the first time at 50 s/h, then every 500 s/h

### Maintenance plan/service hours (s/h)

Maintenance work (once a day)	Every 50 s/h	Every 500 s/h	Every 1000 s/h once a year	Customer	Authorized workshop
-------------------------------	--------------	---------------	----------------------------	----------	---------------------

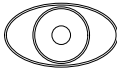


















**WACKER  
NEUSON**

Maintenance

## 5.15 Maintenance label

Explanation of symbols on the maintenance label

Symbol	Assembly	Explanation
	General	Visual check
	General	Grease instructions
	Fuel system	Drain condensation water
	Fuel system	Replace the fuel filter, clean the fuel prefilter
	Radiator	Check the coolant level
	Radiator	Drain and fill in new coolant
	Engine	Check valve tip clearance. Adjust if necessary
	Engine	Check the engine oil level
	Engine	Change the engine oil
	Engine	Replace the oil filter
	Engine	Check V-belt tension
	Hydraulic system	Check oil level
	Hydraulic system	Change the hydraulic oil
	Hydraulic system	Replace the hydraulic oil filter, replace the breather filter
	Radiator fins	Clean
	Heating, air conditioning	Replace the recirculated air filter
	Undercarriage	Check track tension



