

F10000910

MODEL CODE



ESCORTS

PARTS CATALOGUE FARMTRAC



FARMTRAC 675 - TIER II EXPORT

NOTICE

The Description and Illustrations in this Parts Catalogue may not necessarily match with the appearance of the actual Parts. Escorts Ltd. reserves the right to carry out modifications on the Product, Parts or Accessories, as may be considered necessary from time to time, without being obliged to update this Parts Catalogue immediately.

No part of this publication may be reproduced without the written consent of Escorts Ltd.

Model Code : F10000910

Publication No : EPC-147

Revision : 0

Issue Date : Mar 05

FARMTRAC

TRACTOR PARTS CATALOGUE

Model : FARMTRAC 675 - TIER II EXPORT

Code : F10000910

FARMTRAC 675 - TIER II PERKINS ENGINE, EXPORT

ESCORTS LIMITED

**Agri Machinery Marketing Division
(Parts & Service)**

Plot No. : 115, Sector-24, Faridabad-121 005, India

Phone 2440084-88, Fax : 2442833

e-mail : SPD_query@Escorts.co.in

FOREWORD

This Parts Catalogue lists all parts of the Specified Model which are offered as spares. The Catalogue has been specially designed to assist in quoting the correct Part Number and the Part Description.

Modifications or additions which may be carried out in the Product after the release of this Catalogue, will be conveyed through our regular Service Technical Bulletins and Updates to this Publication. It is recommended that necessary corrections are made in the parts Catalogue and always kept updated.

PRODUCT SUPPORT
ESCORTS LTD. (AMMD)

CATALOGUE ORGANISATION

CATALOGUE

This comprehensive Parts Catalogue has been prepared to cover the specified models.

The parts catalogue is organised as 'Illustration' on the left hand side and 'Table' on the right hand side, each with a unique Sheet Number. The contents page lists these 'Sheet Numbers' along with the corresponding Figure Numbers used in earlier catalogues.

ILLUSTRATION

The Illustration shows the shape and assembly sequence of individual Parts. The purpose of the Illustration is to identify the part number and relate it to the Table.

- Each part in the illustration has an 'Item Number' which corresponds to the item number in the Table.
- Parts which are available as 'Assembly' or 'Kit' are also identified by an 'Item Number' for the Group.

TABLE

The Table contains the following information

■ ITEM NO

It Indicates the number in the Illustration. eg.

- 1, 1a, etc. : Signifies Item number of the current Part.
- 1-1, 1a-1, etc. : Signifies Item No of the Superseded Part.
- 1-S0, 1a-S1, etc. : Signifies Item number of Variant - Size Specific
- 1-M0, 1a-M1, etc. : Signifies Variant of the Part - Brand Specific

■ PART NUMBER

It is the unique number identifying the Item. Parts are to be ordered based on this number alone. Items shown in Illustration but not assigned a Part No are not Serviced Separately. They are serviced as a KIT or assembly.

■ DESCRIPTION

Denotes the Part name.

■ QUANTITY

This indicates the quantity of the Part as applicable to the specified 'Assembly'.
'AR' Indicates Quantity to be used "As Required".

CATALOGUE ORGANISATION

■ REMARKS

This column contains additional information about the Part.

The standard remarks are as follows.

- NSS-XX Part not serviced separately. Order the part under Item no XX and corresponding Part No.
- KIT Kit consists of more than one Parts Packed Together
- ASSY Assembly or Sub-Assembly consisting of more than one Parts Assembled Together
- FROM-YYYY Indicates Part applicability from TSN/Date
- TO -YYYY Indicates that the part is applicable up to (TSN - Tractor Serial Number)

ABBREVIATIONS

The following abbreviations have been used in the catalogue.

AR	AS REQUIRED	STD	STANDARD
ADJ	ADJUSTING	SSPL	SOUTH SPECIAL
AFA	ADJUSTABLE FRONT AXLE	STRNG	STEERING
ALR	ALUMINIUM RADIATOR	TEMP	TEMPERATURE
ASSY	ASSEMBLY	TPT	TAPPET
AUXH	AUXILIARY HYDRAULICS	TSN	TRACTOR SERIAL NUMBER
BLS	BOTTOM LINK SENSING	TLS	TOP LINK SENSING
BRG	BEARING	UPR	UPPER
BRK	BRAKE	U/S	UNDER SIZE
BRKT	BRACKET	WHL	WHEEL
E	ESCORT	W/O	WITHOUT
CL	CLUTCH	(C)	COLOUR VARIANT
CON ROD	CONNECTING ROD	(P)	PILOT
C/SHFT	CRANKSHAFT	Dxxxxxxx	ESCORT PART NUMBER
CRB	CARRARO BACKEND	*xx...x	PROPRIETORY PART NUMBER
CVR	COVER		
DAC	DRY AIR CLEANER		
DC	DUAL CLUTCH		
DDA	DOUBLE DROP ARM		
DL	DIFFERENTIAL LOCK		
DPTO	DUEL SPEED PTO		
ENG	ENGINE		
EXH	EXHAUST		
FIG	FIGURE		
FIP	FUEL INJECTION PUMP		
FT	FARMTRAC		
GR	GEAR		
HDH	HEAVY DUTY HYDRAULIC		
HSG	HOUSING		
HYD	HYDRAULIC		
IND	INDIGENOUS		
INL	INLET		
INT'BLE	INTERCHAGEABLE		
LH	LEFT HAND		
LPTO	LIVE PTO		
LWR	LOWER		
MS	MANUAL STEERING		
MNTG	MOUNTING		
NO	NUMBER		
NSS-XX	NOT SERVICED SEPERATELY (SERVICED AS PART OF ITEM XX)		
O/S	OVERSIZE		
OSH	OLD SHEET METAL		
PDL	PEDAL		
PS	POWER STEERING		
PT	POWERTRAC		
PTO	POWER TAKE OFF		
RH	RIGHT HAND		
REPL	REPLACES		
RPM	REVOLUTION PER MINUTES		
SC	SINGLE CLUTCH		
SL	STRUT LINKAGE		
SDA	SINGLE DROP ARM		
SHFT	SHAFT		

CONTENTS

SHEET NO	OLD NO	DESCRIPTION	PAGE NO
102101-1	P1	CYLINDER BLOCK AND LINERS	1
102102-1	P2	CRANKSHAFT, MAIN AND BIG END BEARINGS	3
102104-1	P2-1	PISTONS AND RINGS AND CONNECTING RODS	5
102106-1	P3	CYLINDER HEAD ASSEMBLY	7
102121-1	P3-1	CYLINDER HEAD COVER AND BREATHER	9
102108-1	P4	ROCKER SHAFT ASSEMBLY AND CAMSHAFT	11
102139-1	P5	TIMING CASE	13
102141-1	P6	TIMING GEARS	15
102142-1	P6-1	DRIVE ADAPTOR	17
102109-1	P7	FUEL INJECTION PUMP	19
102115-1	P8	ALTERNTOR AND STARTER MOTOR	21
102116-1	P9	FAN DRIVE	23
102118-1	P10	SUMP, DIPSTICK	25
102126-1	P11	OIL FILTER	27
102125-1	P12	OIL COOLER	29
102130-1	P13	WATER PUMP	31
102133-1	P14	WATER OUTLET HOUSING	33
102144-1	P15	LUBRICATING OIL PUMP AND DELIVERY HOUSING	35
102147-1	P19	EXHAUST MANIFOLD	37
102149-1	P20	LIFT PUMP	39
102157-1	P21	FUEL FILTER	41
102160-1	P22	THROTTLE STOP CONTROL AND KITS	43
101964-7	B2	AIR CLEANER (DRY ELEMENT TYPE)	45
101965-1	B3	MANIFOLD INTAKE AND EXHAUST SYSTEM	47
101968-4	B5	FUEL SYSTEM	49
101979-6	C1	RADIATOR	51
101981-2	D1	FRONT WHEEL ASSEMBLY	53
101982A-1	D2	FRONT AXLE AND STEERING PARTS	55
103107A-1	D4	PUMP HYDRAULIC / STEERING AND MOTOR	59
101989-3	E2	CLUTCH HOUSING	63
101990-1	E3	CLUTCH INNER CONTROLS	65
101991-2	E4	CLUTCH OUTER CONTROLS	67
101992-2	E5	PTO CLUTCH OUTER CONTROL	69
101993-1	E6	CLUTCH ASSEMBLY	71
101994-1	E7	CLUTCH SHAFTS	73
101995-1	F1	HOUSING GEAR BOX	75
101996-1	F2	LEVERS COVER	77
101997-1	F3	TRANSMISSION OUTER CONTROL	79
101998A-1	F4	REVERSE OUTER CONTROL	81
101999-1	F5	GEAR BOX INNER CONTROLS	83
102000-1	F6	REDUCER INNER CONTROLS	85
102001-1	F7	REVERSE INNER CONTROLS	87
102002-1	F8	PRIMARY SHAFT, GEARS	89
102003-1	F9	SECONDARY SHAFT, GEARS	91
102004-1	F10	REVERSE GEARS	93
102005-1	G1	REAR DIFFERENTIAL	95
102006A-1	G2	BEVEL GEAR SET, DIFFERENTIAL	97
102007-1	G3	REAR DIFFERENTIAL LOCK	99
102008-1	G4	DIFFERENTIAL LOCK LINKAGE	101
102009-1	G5	PTO INNER GEAR AND SHAFT	103
102010-1	G6	PTO OUTER CONTROLS	105
102011-1	G7	PTO 540 RPM	107
102012-1	G8	PTO 540/1000 RPM	109

CONTENTS

SHEET NO	OLD NO	DESCRIPTION	PAGE NO
102013-3	G9	PTO OUTER CONTROLS 540/1000	111
102014-4	G10	PTO GUARD	113
102015-1	G11	AXLE SHAFTS	115
102016-1	G12	FINAL DRIVE HOUSING	117
102017-7	G13	REAR WHEELS	119
102018-1	H1	BRAKE ASSEMBLY	121
102019-3	H2	BRAKE PEDAL	123
102020-1	H3	BRAKE RELEASE SYSTEM	125
102021-1	H4	HAND BRAKE SYSTEM	127
102022-1	I1	HYDRAULIC BODY	129
102023-1	I2	RAM CYLINDER	131
102024-1	I3	INSIDE LIFTING CONTROLS	133
102025-1	I4	YOKE TOP LINK SENSING	135
102026-1	I5	OUTER LIFTING CONTROLS	137
102027-5	I6	OUTER LIFTING CONTROL LEVERS	139
102028-1	I7	MAIN DISTRIBUTOR VALVE	141
102029-4	I8	HYDRAULIC LIFT LINKAGE	143
102030-5	I10	DOUBLE ACTING TWO WAY SPOOL VALVE (VV)	145
102035-3	J3	BATTERY AND BATTERY SUPPORT	147
102036-5	J4	ELECTRICAL SWITCHES AND CONTROLS	149
102037-2	J5	INSTRUMENT CLUSTER AND TACHO DRIVE	151
102038-4	J6	WIRING HARNESS SYSTEM	153
102039-7	J7	HEAD LAMP AND WORK LAMP	155
102047-11	K2	RUNNING BOARD	157
102048A-6	K3	FENDERS	159
102049-4	K4	DELUXE SEAT ASSEMBLY	161
102050A-11	K5	DECALS AND TOOL KIT	163
102051-2	K6	TOW HOOK	165
102054A-3	K9	SWINGING DRAW BAR	167

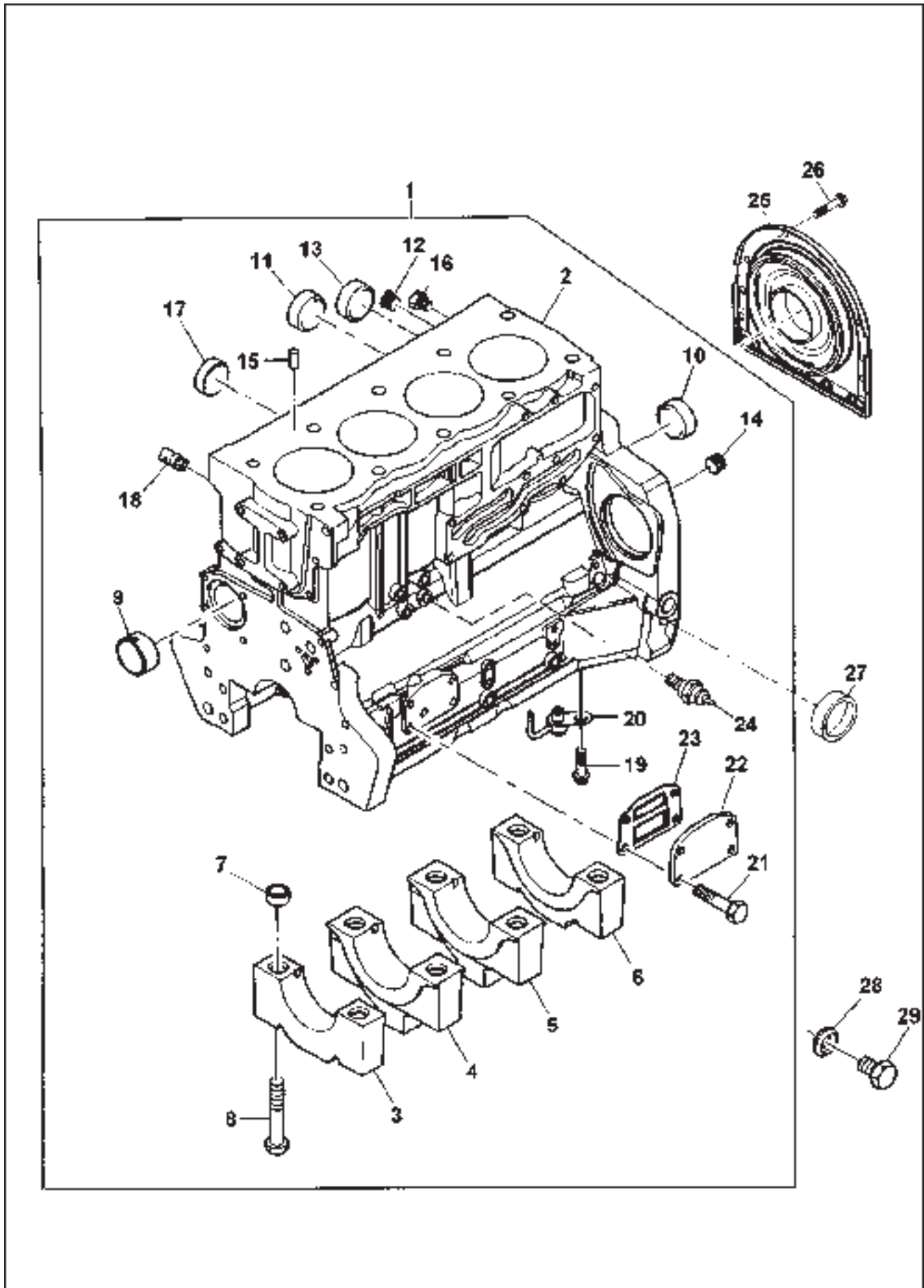

ITEM No.	PART NO.	DESCRIPTION	QTY	REMARKS
1	*ZZ50312	CYLINDER BLOCK KIT	1	
2		CYLINDER BLOCK	1	NSS-1
3		BEARING CAP	1	NSS-1
4		BEARING CAP	2	NSS-1
5		BEARING CAP	1	NSS-1
6		BEARING CAP	1	NSS-1
7		THIMBLE	10	NSS-1
8	*32166329	SCREW	10	
9	*3112D071	CAMSHAFT BUSH	1	
10	*3241A012	PLUG	1	
11	*3241A011	PLUG	2	
12	*0650588	PLUG	1	
13	*0650710	PLUG	1	
14	*3212P008	PLUG	1	
15	*3244A009	DDOWEL	2	
16	*32141316	PLUG	2	
17	*2485A108	BLANKING PLUG	1	
18	*3212V006	PLUG	1	
19	*2314F001	SCREW	4	
20	*2113A001	PISTON COOLING JET	4	
21	*2314H033	SCREW	4	
22	*3623A009	BLANKING PLATE	1	
23	*3688A039	JOINT	1	
24	*2848062	OIL PRESSURE SWITCH	1	
25	*2418F704	REAR OIL SEAL HOUSING	1	
26	*3211C002	METRIC BOLT	10	
27	*2485A109	CORE PLUG	1	
28	*2415D053	PLAIN WASHER	1	
29	*2314C049	SCREW	1	
* - REFER ABBREVIATIONS PAGE				

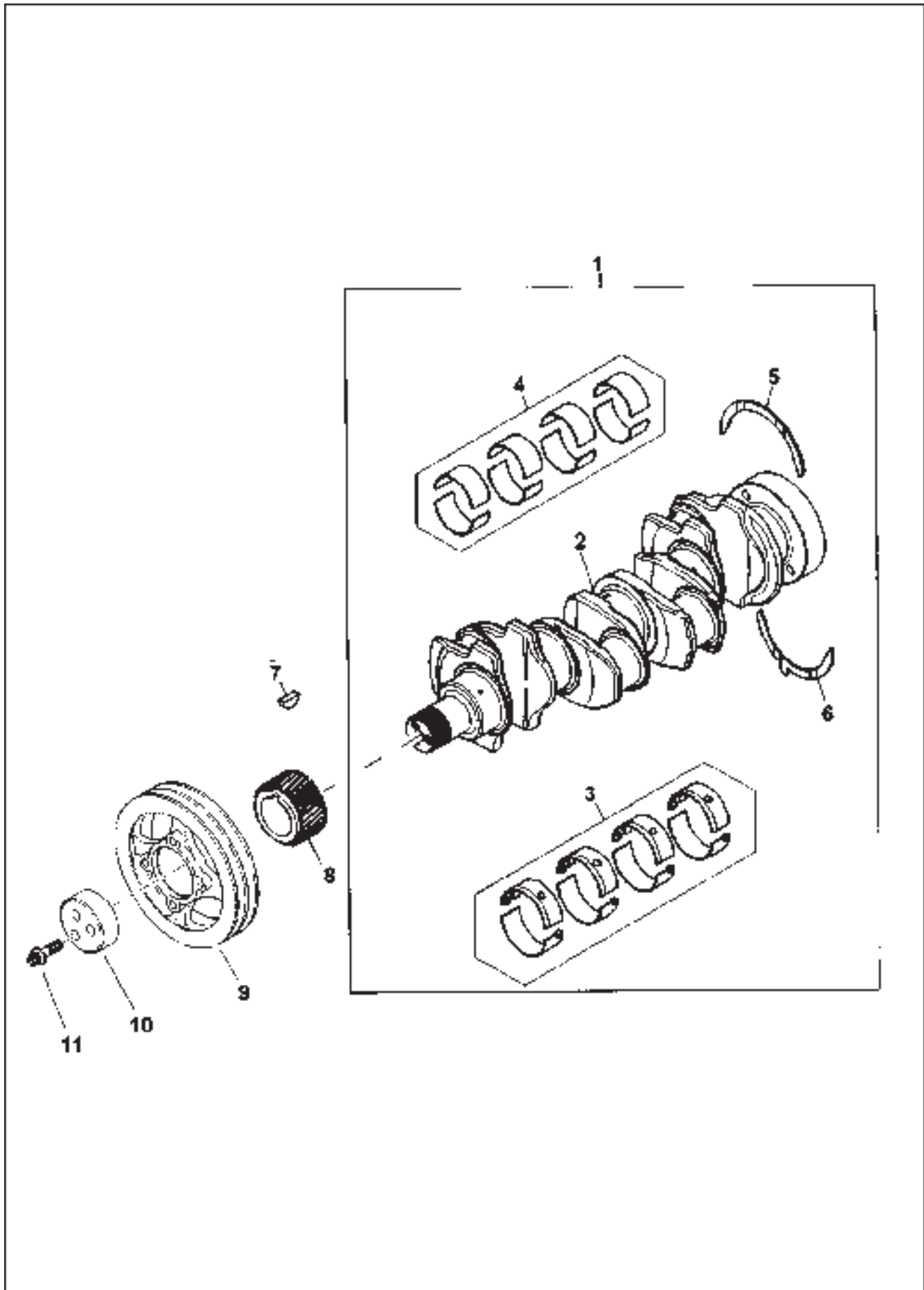

ITEM No.	PART NO.	DESCRIPTION	QTY	REMARKS
1	*ZZ90224	CRANKSHAFT KIT	1	NSS-1
2		CRANKSHAFT	1	
3	*U5MB0019	MAIN BEARING KIT	1	
4	*U5ME0013	BIG END BEARING KIT	1	
5	*31137551	THRUST WASHER	2	
6	*31137561	THRUST WASHER	2	
7	*500012	WOODRUFF KEY	1	
8	*3117C221	CRANKSHAFT GEAR	1	
9	*3115T051	CRANKSHAFT PULLEY	1	
10	*3241N001	BLOCK	1	
11	*32186137	BOLT	3	
12	*ZZ90224P	CRANKSHAFT KIT	1	
3-S1	*USMB0019A	MAIN BEARING KIT(-) 0.25MM	1	
3-S2	*U5MB0019B	MAIN BEARING KIT(-) 0.50MM	1	
3-S3	*U5MB0019C	MAIN BEARING KIT(-) 0.75MM	1	
4-S1	*U5MB0013A	BIG END BEARING KIT(+) 0.010"	1	
4-S2	*U5MB0013B	BIG END BEARING KIT(+) 0.020"	1	
4-S3	*U5ME0013C	BIG END BEARING KIT(+) 0.030"	1	
5-S1	*31137312	THRUST WASHER(+) 0.007"	2	
6-S1	*3113322	THRUST WASHER(+) 0.007"	2	
* - REFER ABBREVIATIONS PAGE				

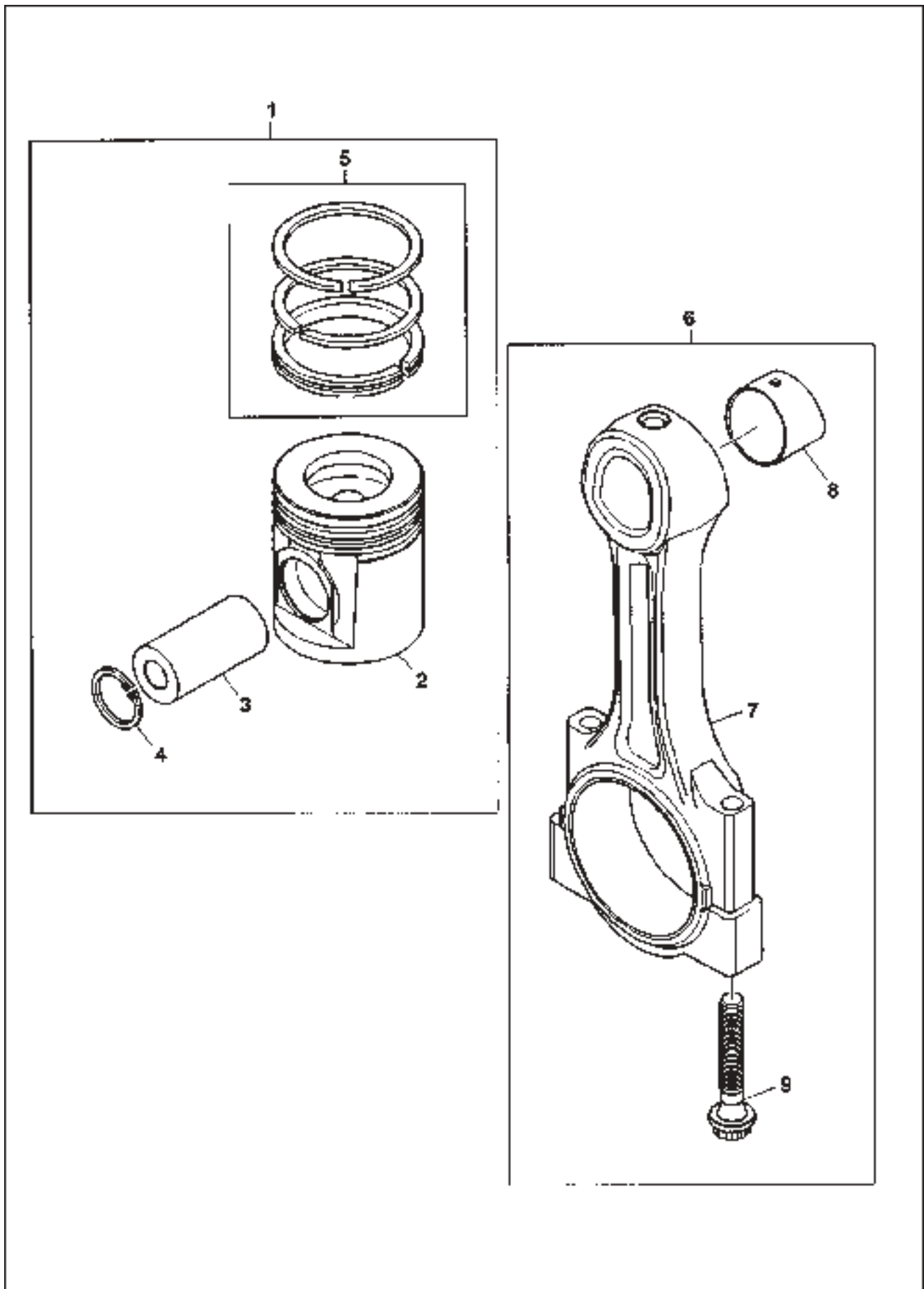

ITEM No.	PART NO.	DESCRIPTION	QTY	REMARKS
1	*4115P011	PISTON AND RING KIT	4	
2		PISTON	1	NSS-1
3		PISTON PIN	1	NSS-1
4	*271332	CIRCLIP	2	
5	*UPRK0003	PISTON RING KIT	1	
6		CONROD KIT	4	NSS-S6
7		CONROD	1	NSS-S6
8	*3112A005	SMALL END BUSH	1	
9	*3212V003	CON ROD BOLT	2	
6	*4115C311	CONROD KIT	4	
6	*4115C312	CONROD KIT	4	
6	*4115C313	CONROD KIT	4	
6	*4115C314	CONROD KIT	4	
6	*4115C315	CONROD KIT	4	
6	*4115C316	CONROD KIT	4	
* - REFER ABBREVIATIONS PAGE				

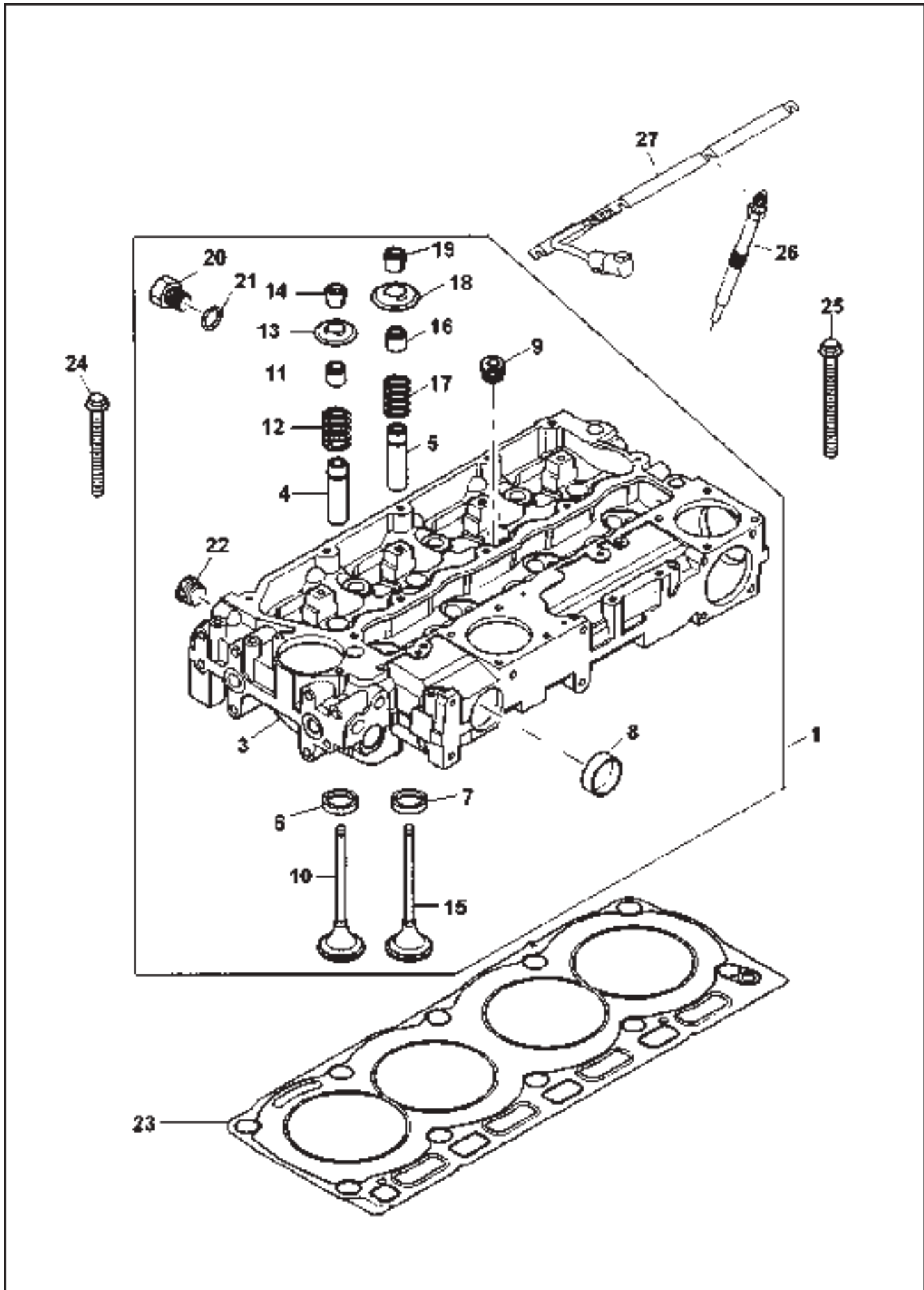

ITEM No.	PART NO.	DESCRIPTION	QTY	REMARKS
1	*ZZ80270	CYLINDER HEAD KIT	1	
2	*ZZ80270	CYLINDER HEAD ASSEMBLY	1	NSS-1
3		CYLINDER HEAD	1	NSS-1
4	*3313E021	VALVE GUIDE	4	
5	*3313E021	VALVE GUIDE	4	
6	*3314A151	INLET VALVE INSERT	4	
7	*3314A161	EXHAUST VALVE INSERT	4	
8	*32416117	PLUG	2	
9	*0650588	PLUG	4	
10	*3142H071	INLET VALVE	4	
11	*2418M519	VALVE STEM SEAL	4	
12	*3174A016	VALVE SPRING	4	
13	*3342A011	VALVE CAP	4	
14	*3342W004	COTTER	8	
15	*3142A151	EXHAUST VALVE	4	
16	*2418M514	VALVE STEM SEAL	4	
17	*3174A016	VALVE SPRING	4	
18	*3342A011	VALVE CAP	4	
19	*3142W004	COTTER	8	
20	*3278A006	PLUG	1	
21	*241H003	O RING	1	
22	*2431154	PLUG	1	
23	*3681E051	CYLINDER HEAD GASKET	1	
24	*3218A011	SCREW	7	
25	*3218A012	SCREW	3	
26	*2666A016	GLOW PLUG	4	
27	*3161C015	BAR	1	
* - REFER ABBREVIATIONS PAGE				

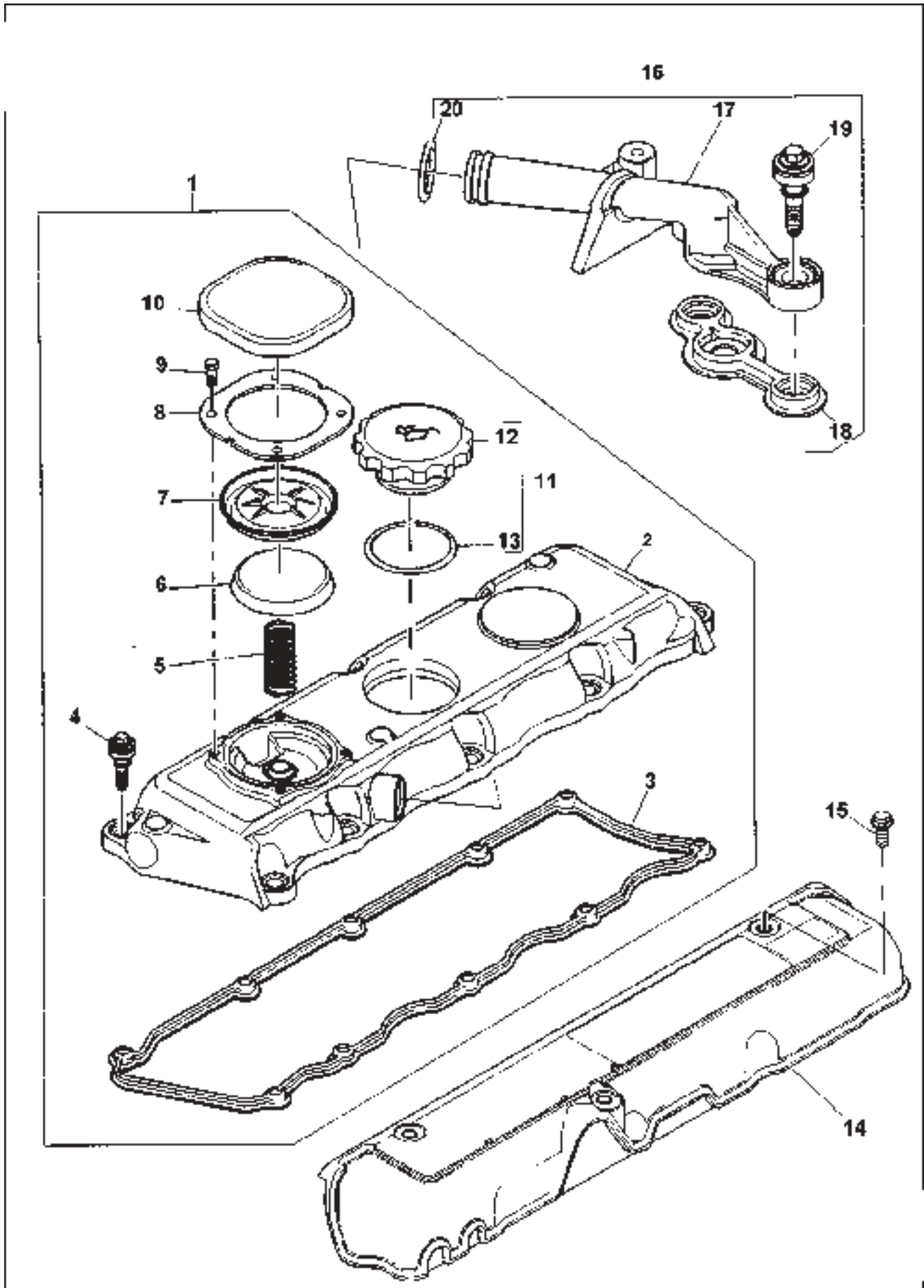

ITEM No.	PART NO.	DESCRIPTION	QTY	REMARKS
1	*4142X292	CYLINDER HEAD COVER ASSY	1	NSS-1
2		CYLINDER HEAD COVER	1	
3	*3681A055	ROCKER COVER JOIN	1	
4	*2161A011	SCREW	10	
5	*3174A017	SPRING	1	
6	*3788A002	CAP	1	
7	*3789A001	DIAPHRAGM	1	
8	*3615A009	COVER PLATE	1	
9	*2151A001	SCREW	4	
10	*3788A003	CAP	1	
11	*4142X099	OIL FILLER CAP	1	NSS-11
12		OIL FILLER CAP	1	
13	*2415A131	O RING	1	
14	*3788N003	COVER	1	
15	*2314F003	SCREW	3	
16	*4134K014	BREATHER PIPE	1	NSS-16
17		BREATHER PIPE	1	
18		JOINT	1	
19		SCREW	2	
20		O RING	1	
		* - REFER ABBREVIATIONS PAGE		

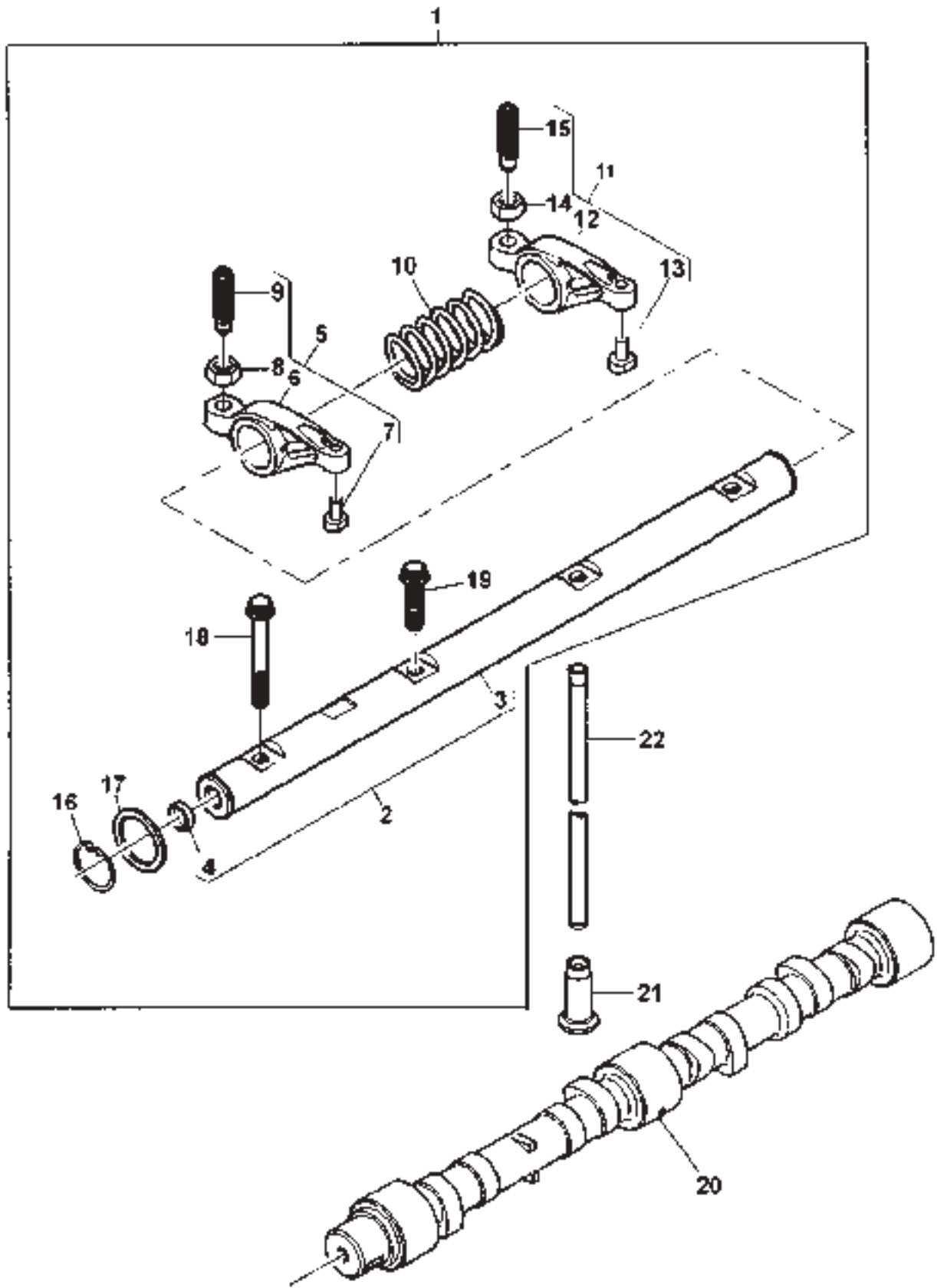

ITEM No.	PART NO.	DESCRIPTION	QTY	REMARKS
1	*4115R612	ROCKER ASSEMBLY	1	NSS-2
2	*4115R703	ROCKER SHAFT ASSEMBLY	1	
3		ROCKER ARM SHAFT	1	
4	*2485A104	PLUG	2	
5	*4115R314	ROCKER ARM ASSEMBLY	4	
6		ROCKER ARM	1	NSS-5
7		PAD	1	NSS-5
8	*O576052	NUT	1	
9	*32114145	SCREW	1	
10	*3174A015	ROCKER SHAFT SPRING	3	
11	*4115R315	ROCKER ARM ASSEMBLY	4	NSS-11 NSS-11
12		ROCKER ARM	1	
13		PAD	1	
14	*O576052	NUT	1	
15	*32114145	SCREW	1	
16	*2722A022	CIRCLIP	2	
17	*2134A302	WASHER	2	
18	*2316A901	SCREW	1	
19	*231A902	SCREW	3	
20	*3141D212	CAMSHAFT	1	
21	*3142U031	TAPPET	8	
22	*31434307	PUSHROD	9	
* - REFER ABBREVIATIONS PAGE				

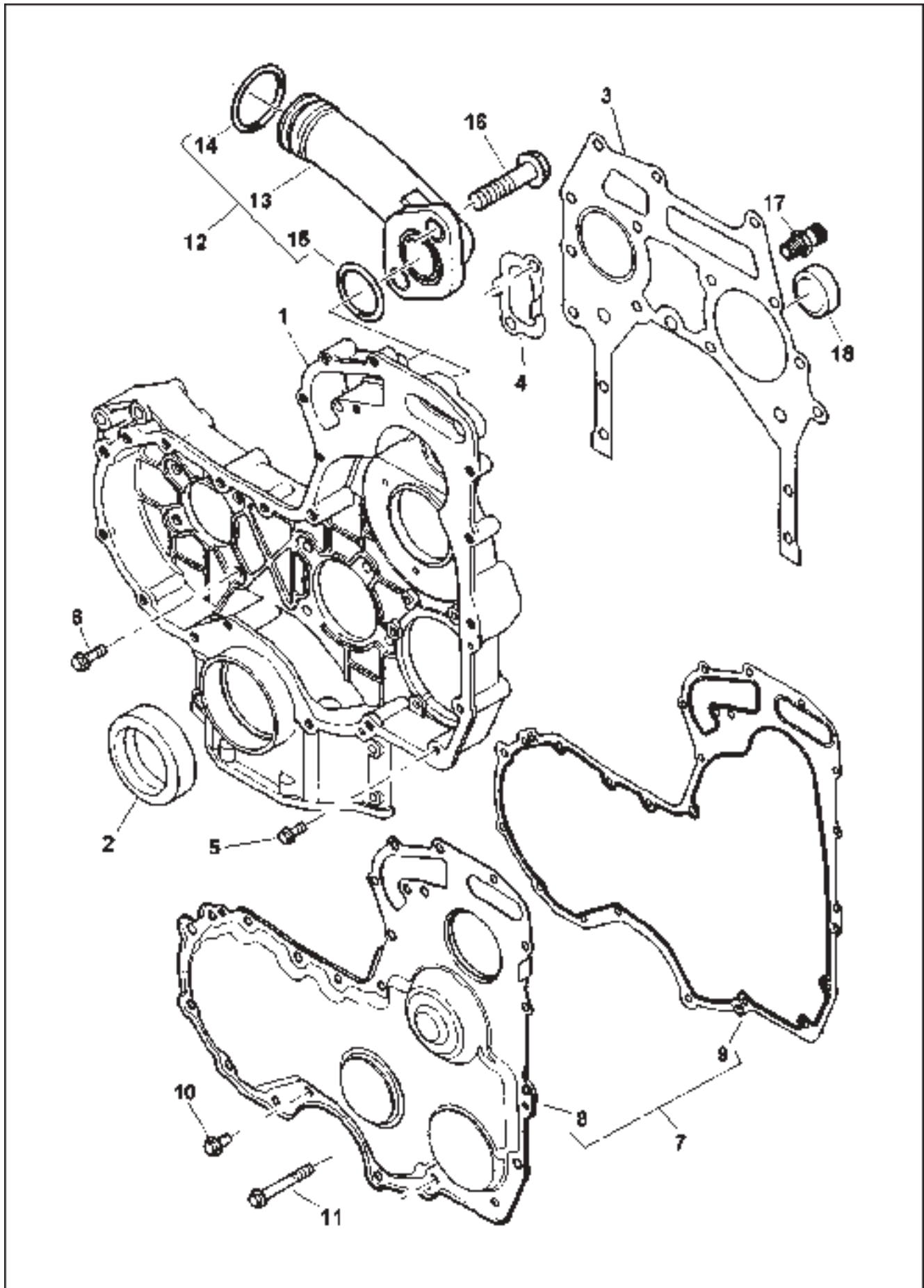

ITEM No.	PART NO.	DESCRIPTION	QTY	REMARKS
1	*3716C471	TIMING CASE	1	
2	*2418F436	FRONT OIL SEAL	1	
3	*3617V015	TIMING CASE JOINT	1	
4	*3617V016	TIMING CASE JOINT	1	
5	*2314H003	SCREW	8	
6	*2314H034	SCREW	4	
7	*4142A504	TIMING GEAR COVER	1	
8		TIMING COVER	1	NSS-7
9	*3681P047	COVER JOINT	1	
10	*2314H002	SCREW	9	
11	*2314H012	SCREW	6	
12	*4133L048	CONNECTION	1	
13		CONNECTION	1	NSS-12
14	*2418F002	O RING	1	
15	*2418F001	O RING	1	
16	*2314H003	SCREW	2	
17	*33552414	ADAPTOR	1	
18	*2485A124	CUP PLUG	1	
* - REFER ABBREVIATIONS PAGE				

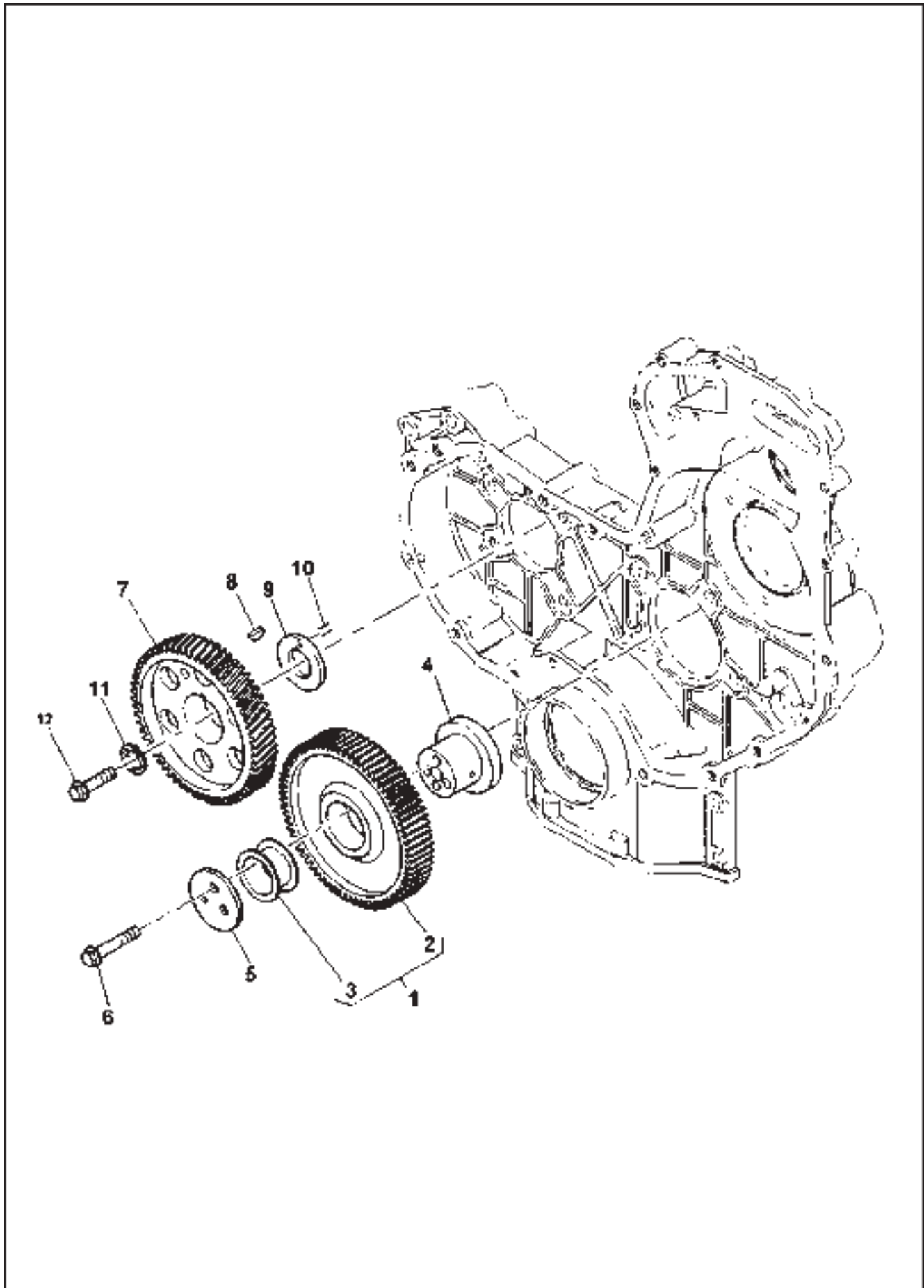

ITEM No.	PART NO.	DESCRIPTION	QTY	REMARKS
1	*4111A034	IDLER GEAR	1	NSS-1
2		IDLER GEAR	1	
3	*0050345	BUSH	2	
4	*33426161	HUB	1	
5	*3241H009	PLATE	1	
6	*2314J010	SCREW	3	
7	*3117N001	CAMSHAFT GEAR	1	
8	*0500012	WOODRUFF KEY	1	
9	*3321A003	WASHER	1	
10	*2116053	DOWEL	1	
11	*3112X011	THRUST WASHER	1	
12	*2314J606	SCREW	1	
* - REFER ABBREVIATIONS PAGE				

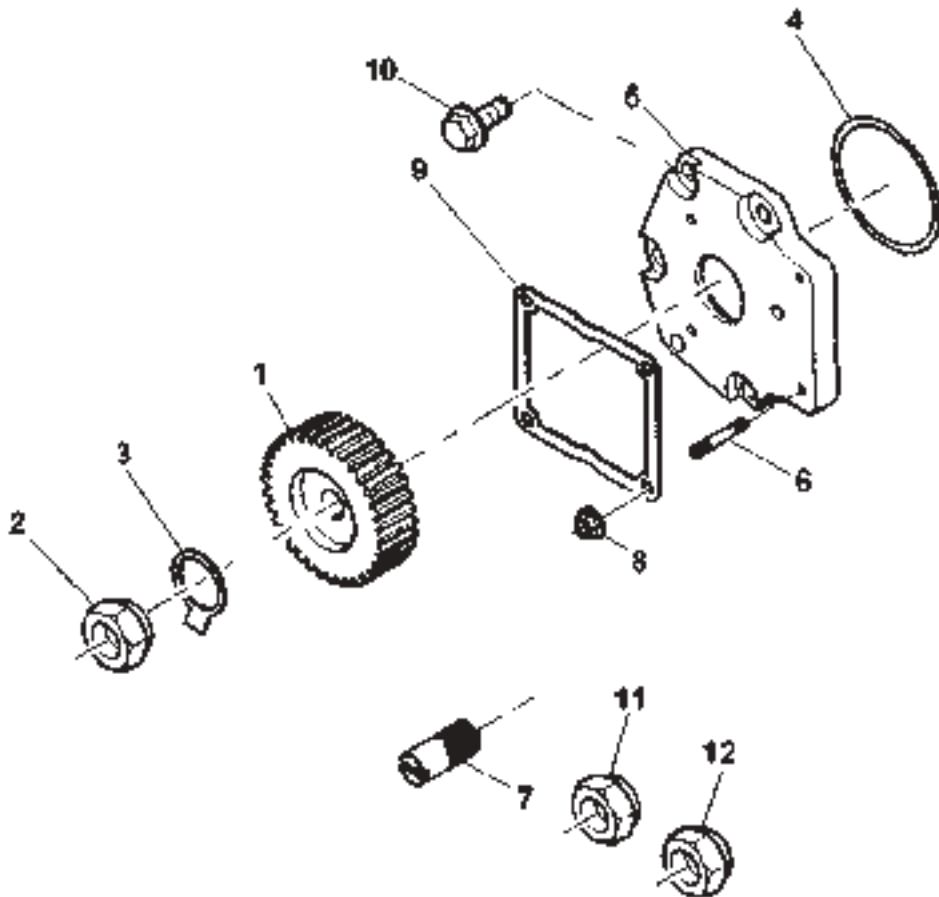

ITEM No.	PART NO.	DESCRIPTION	QTY	REMARKS
1	*3117C231	GEAR	1	
2	*33531119	NUT	1	
3	*31733509	WASHER	1	
4	*2415B167	O RING	1	
5	*3751K082	ADAPTOR	1	
6	*2313M058	STUD	4	
7	*3211C001	PIN	1	
8	*2308A603	NUT	4	
9	*490373	JOINT	1	
10	*2314F037	SCREW	4	
11	*33531137	NUT	1	
12	*33531115	NUT	1	
1	*33531115	NUT	1	
2	*33531137	NUT	1	
* - REFER ABBREVIATIONS PAGE				

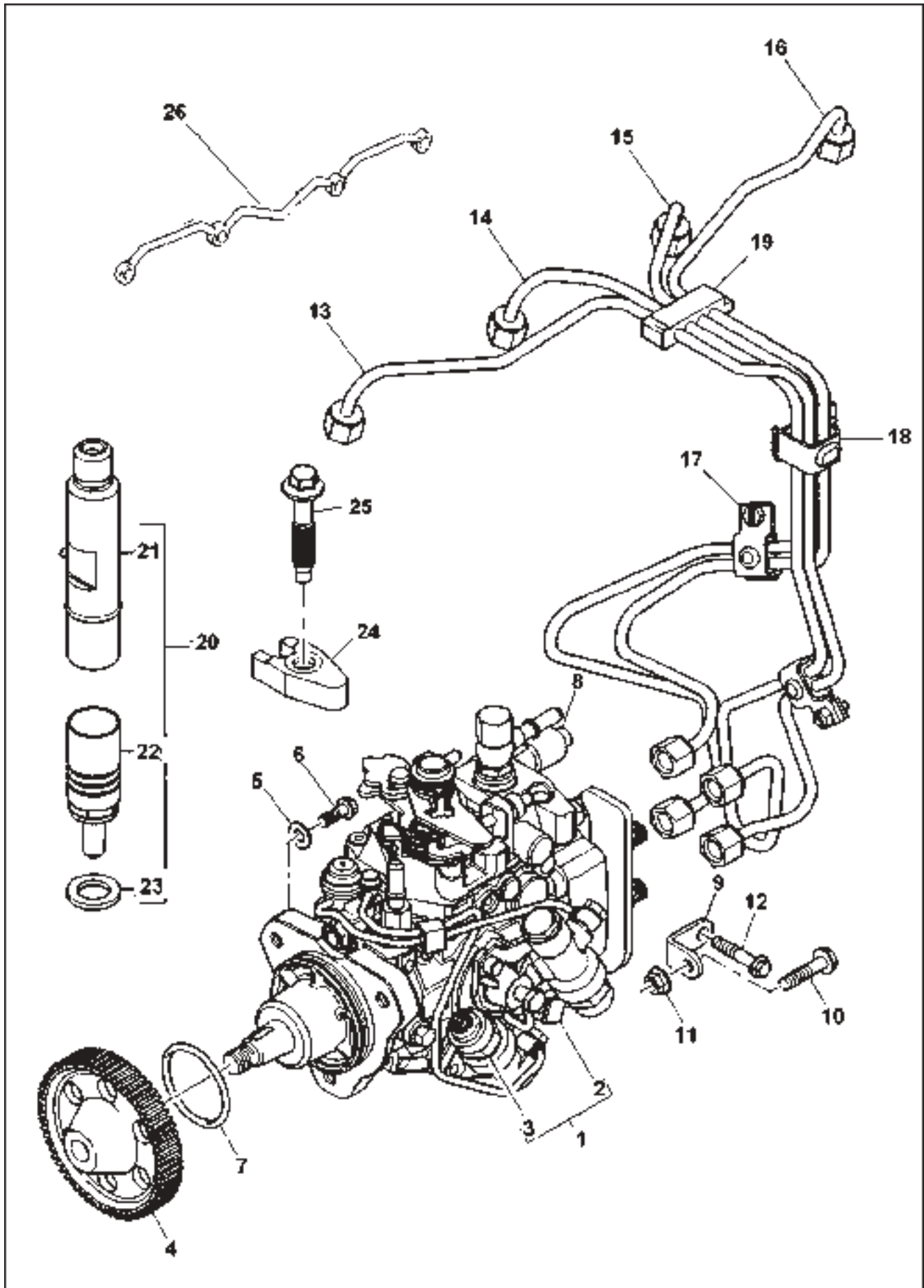

ITEM No.	PART NO.	DESCRIPTION	QTY	REMARKS
1	*2644N202/22	FUEL INJECTION PUMP	1	
2		FUEL INJECTION PUMP	1	NSS-1
3		SOLENOID	1	NSS-1
4	*3117L251	FUEL INJECTION PUMP GEAR	1	
5	*2411D008	WASHER	3	
6	*2314H004	SCREW	3	
7	*2415787	O RING	1	
8	*2487D002	CAP	1	
9	*3641A007	BRACKET	1	
10	*2314H003	SCREW	1	
11	*2318A603	NUT	1	
12	*2314J002	SCREW	1	
13	*3525A091	FUEL INJECTION PIPE - NO.1	1	
14	*3525A092	FUEL INJECTION PIPE - NO.2	1	
15	*3525A093	FUEL INJECTION PIPE - NO.3	1	
16	*3525A094	FUEL INJECTION PIPE - NO.4	1	
17	*2481Y011	CLIP	2	
18	*2481Y012	CLIP	1	
19	*2646E019	CLIP	1	
20	*2645K013	ATOMISER	4	
21		ATOMISER HOLDER	4	NSS-20
22		NOZZLE	4	NSS-20
23	*L311FF02	INJECTOR WASHER	4	
24	*3751A241	INJECTOR CLAMP	4	
25	*231W009	SCREW	4	
20		EXCHANGE ATOMISER	4	
		* - REFER ABBREVIATIONS PAGE		

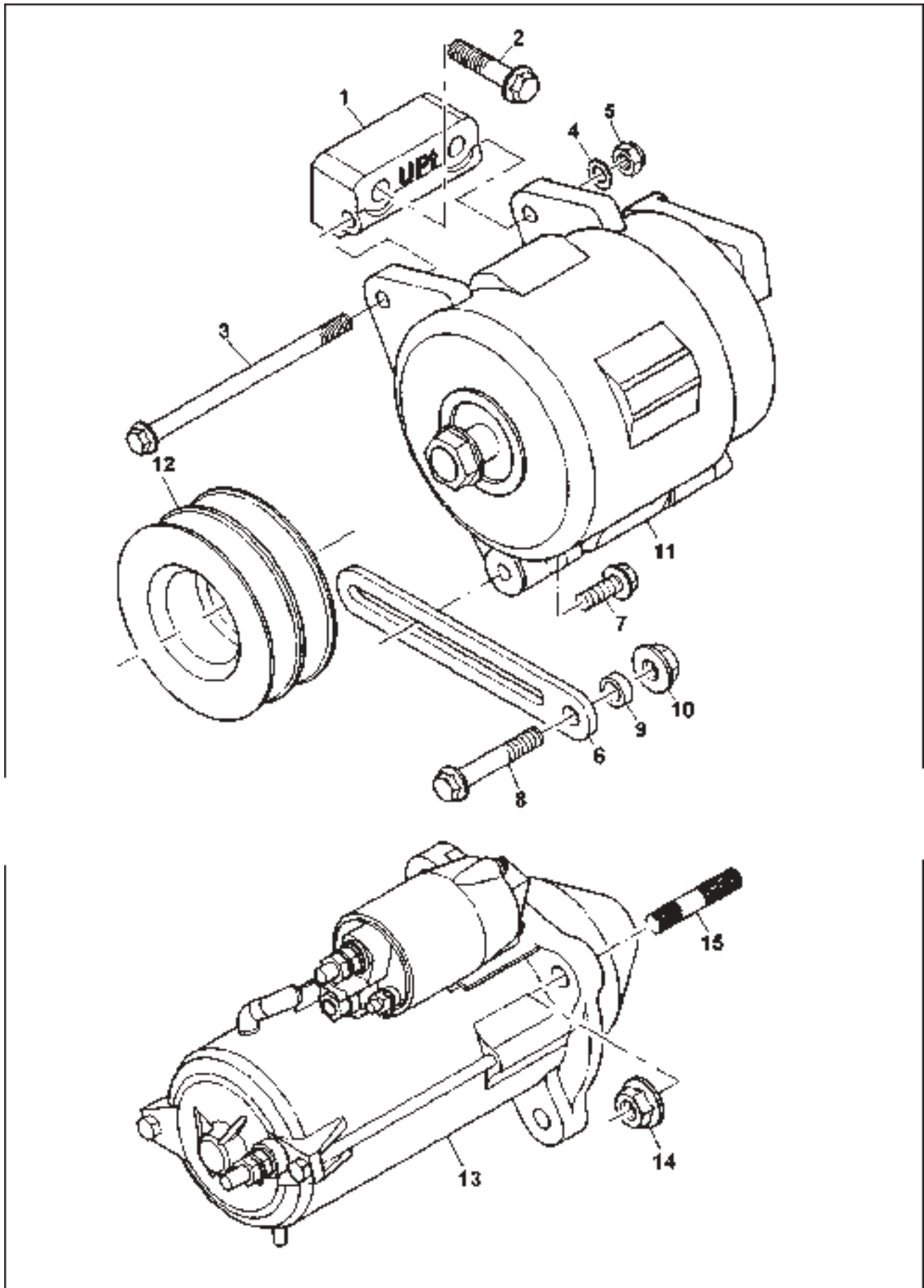

ITEM No.	PART NO.	DESCRIPTION	QTY	REMARKS
1	*3824A071	ALTERNATOR BRACKET	1	
2	*2314J007	SCREW	2	
3	*2314H052	SCREW	1	
4	*2131A008	WASHER	1	
5	*2318D208	NUT	1	
6	*36155429	LEVER	1	
7	*2314H103	SCREW	1	
8	*2314J012	SCREW	1	
9	*0920465	SPACER	1	
10	*2318A604	NUT	1	
11	*2871A301	ALTERNATOR	1	
12	*3115A049	2 GROOVE ALTERNATOR PULLEY	1	
13	*2873K405	STARTER MOTOR	1	
14	*2313C078	STUD	3	
15	*2318A604	NUT	3	
* - REFER ABBREVIATIONS PAGE				

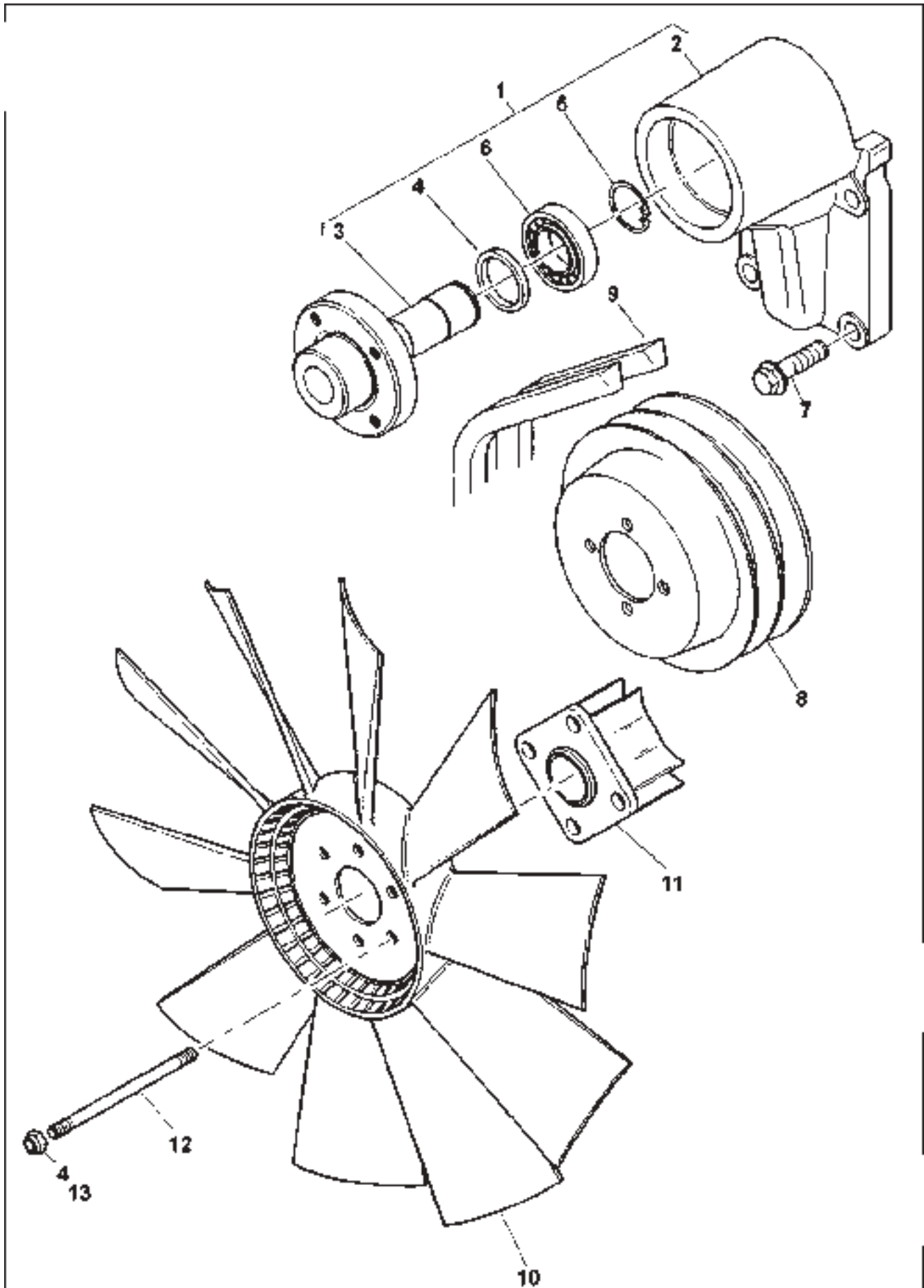

ITEM No.	PART NO.	DESCRIPTION	QTY	REMARKS
1	*4113K006	FAN DRIVE HOUSING	1	
2		FAN DRIVE HOUSING	1	NSS-1
3		HUB	1	NSS-1
4		SPACER	1	NSS-1
5	*2722A022	CIRCLIP	1	
6		BALL BEARING	2	NSS-1
7	*2314J005	SCREW	4	
8	*3115C113	FAN PULLY	1	
9	*2614B662	FAN BELT	1	
10	*2485C522	FAN	1	
11	*3748W232	EXTENSION	1	
12	*2313H233	STUD	4	
13	*2318D208	NUT	4	
* - REFER ABBREVIATIONS PAGE				

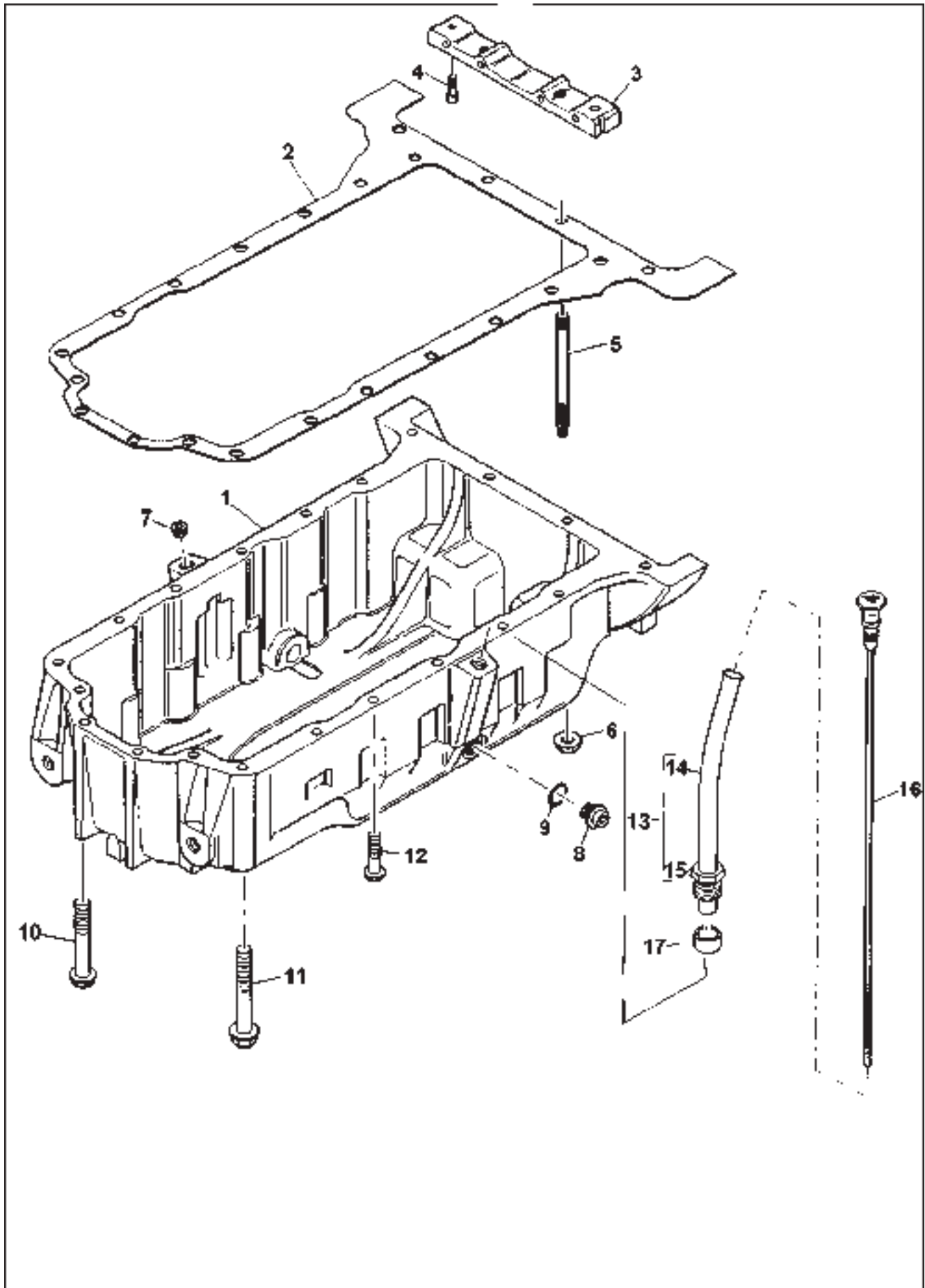

ITEM No.	PART NO.	DESCRIPTION	QTY	REMARKS
1	*3717E271	SUMP	1	
2	*3681K036	SUMP JOINT	1	
3	*3627[041	BRIDGE PIECE	1	
4	*2311D039	SCREW	2	
5	*3211P013	STUD	2	
6	*2318A603	NUT	2	
7	*2431A016	PLUG	1	
8	*32186405	PLUG	2	
9	*2415715	O RING	2	
10	*2314H023	SCREW	5	
11	*2314H022	SCREW	1	
12	*231H015	SCREW	12	
13	*3577A125	TUBE ASSEMBLY	1	
14		TUBE	1	NSS-13
15	*3533D005	NUT	1	
16	*3178C081	DIPSTICK	1	
17	*33812116	OLIVE	1	
* - REFER ABBREVIATIONS PAGE				

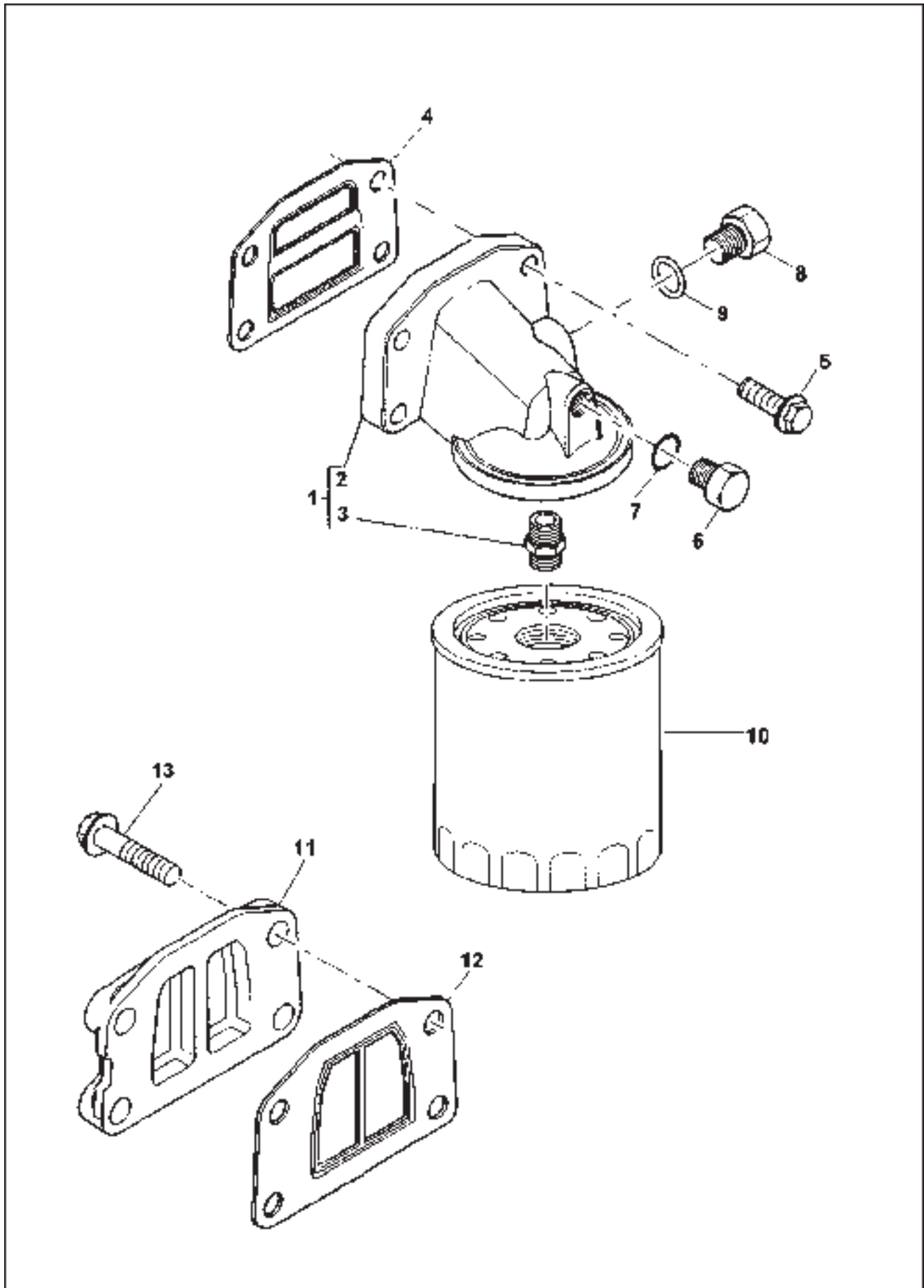

ITEM No.	PART NO.	DESCRIPTION	QTY	REMARKS
1	*4134E058	OIL FILTER HEAD	1	NSS-1
2		OIL FILTER HEAD	1	
3	*33554128	CONNECTION	1	
4	*3688A039	JOINT	1	
5	*2314H034	SCREW	4	
6	*3278A007	PLUG	1	
7	*2415H009	O RING	1	
8	*3278A004	PLUG	1	
9	*2415H002	O RING	1	
10	*2654407	OIL FILTER	1	
11	*3753A071	BLANKING COVER	1	
12	*3688A041	JOINT	1	
13	*2314H034	SCREW	4	
		* - REFER ABBREVIATIONS PAGE		

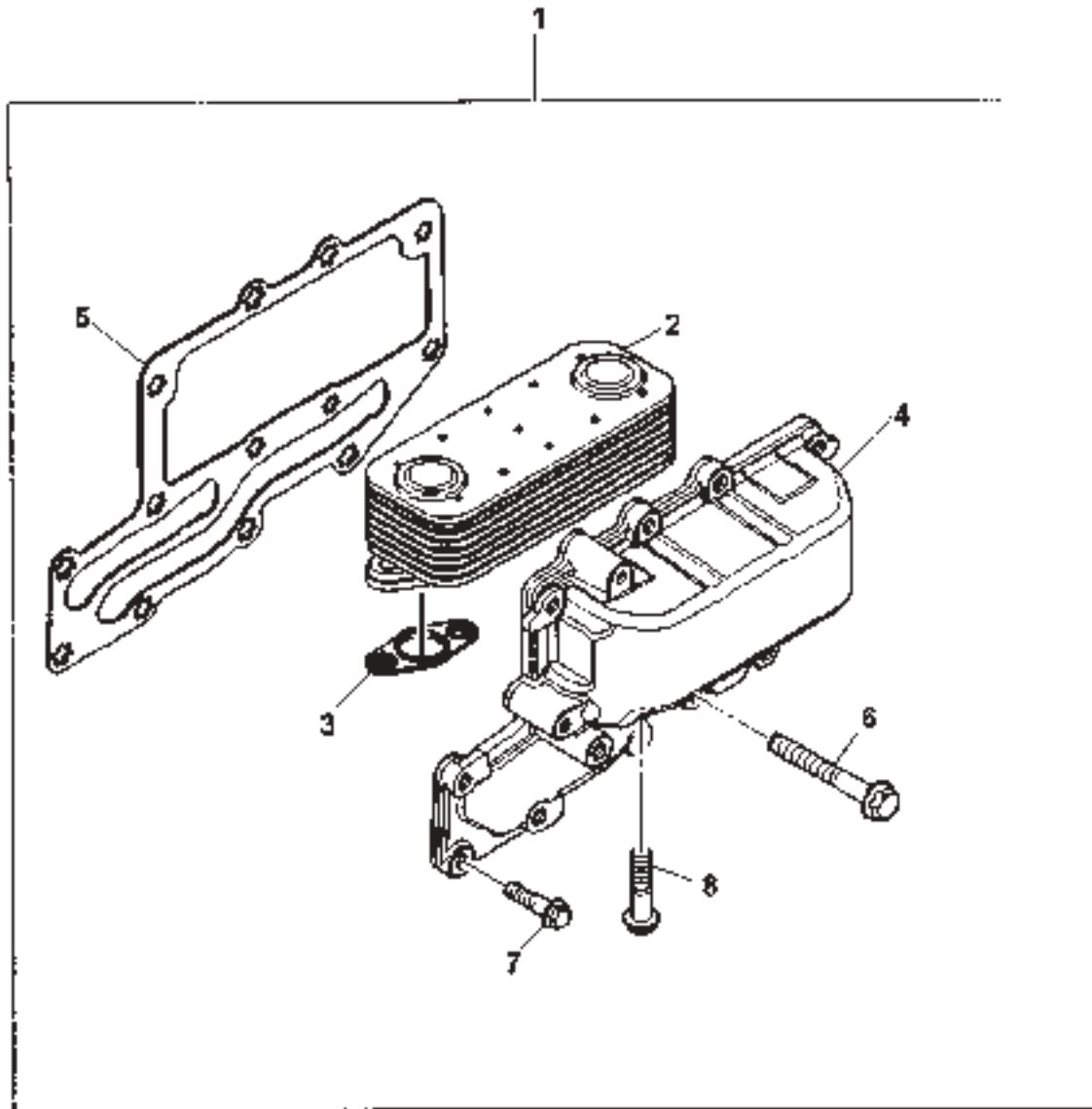

ITEM No.	PART NO.	DESCRIPTION	QTY	REMARKS
1	*4134W003	OIL COOLER	1	NSS-1
2	*2486A215	OIL COOLER	1	
3	*3685A025	JOINT	2	
4		COOLER		
5	*3685A024	JOINT	1	
6	*2314K161	SCREW	3	
7	*2314H004	SCREW	10	
8	*2314H006	SCREW	4	
* - REFER ABBREVIATIONS PAGE				

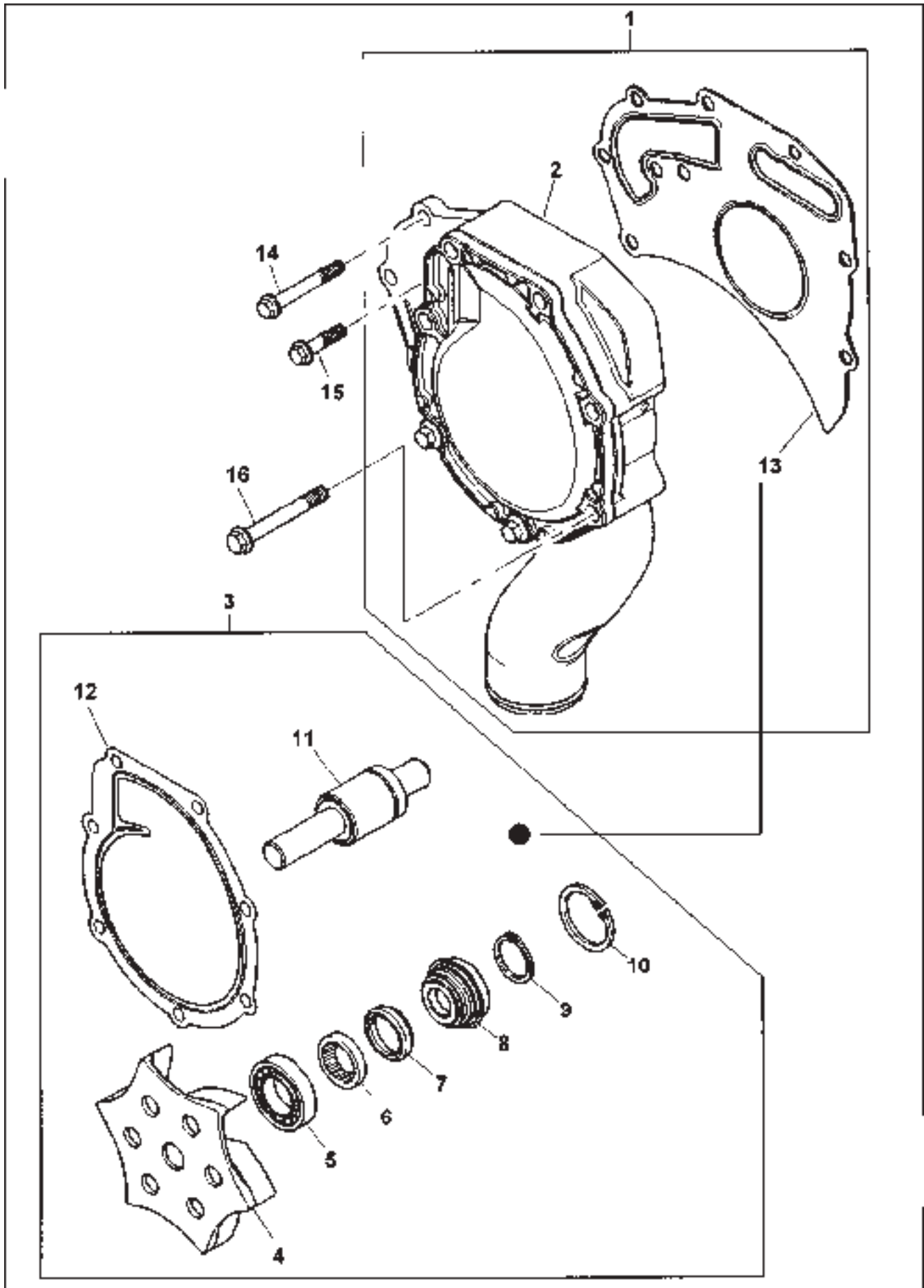

ITEM No.	PART NO.	DESCRIPTION	QTY	REMARKS
1	*U5MW0194	WATER PUMP KIT	1	
2		WATER PUMP	1	NSS-1
3	*U7LW0172	WATER PUMP REPAIR KIT	1	
4		IMPELLER	1	NSS-3
5		ROLLER BEARING	1	NSS-3
6		BEARING	1	NSS-3
7		OIL SEAL	1	NSS-3
8		SEAL	1	NSS-3
9		CIRCLIP	1	NSS-3
10		CIRCLIP	1	NSS-3
11	*24880234	COVER JOINT	1	
12		DRIVE SHAFT	1	NSS-3
13	*3682A011	WATER PUMP JOINT	1	
14	*2314K164	SCREW	2	
15	*2314H005	SCREW	2	
16	*2314H012	SCREW	5	
* - REFER ABBREVIATIONS PAGE				

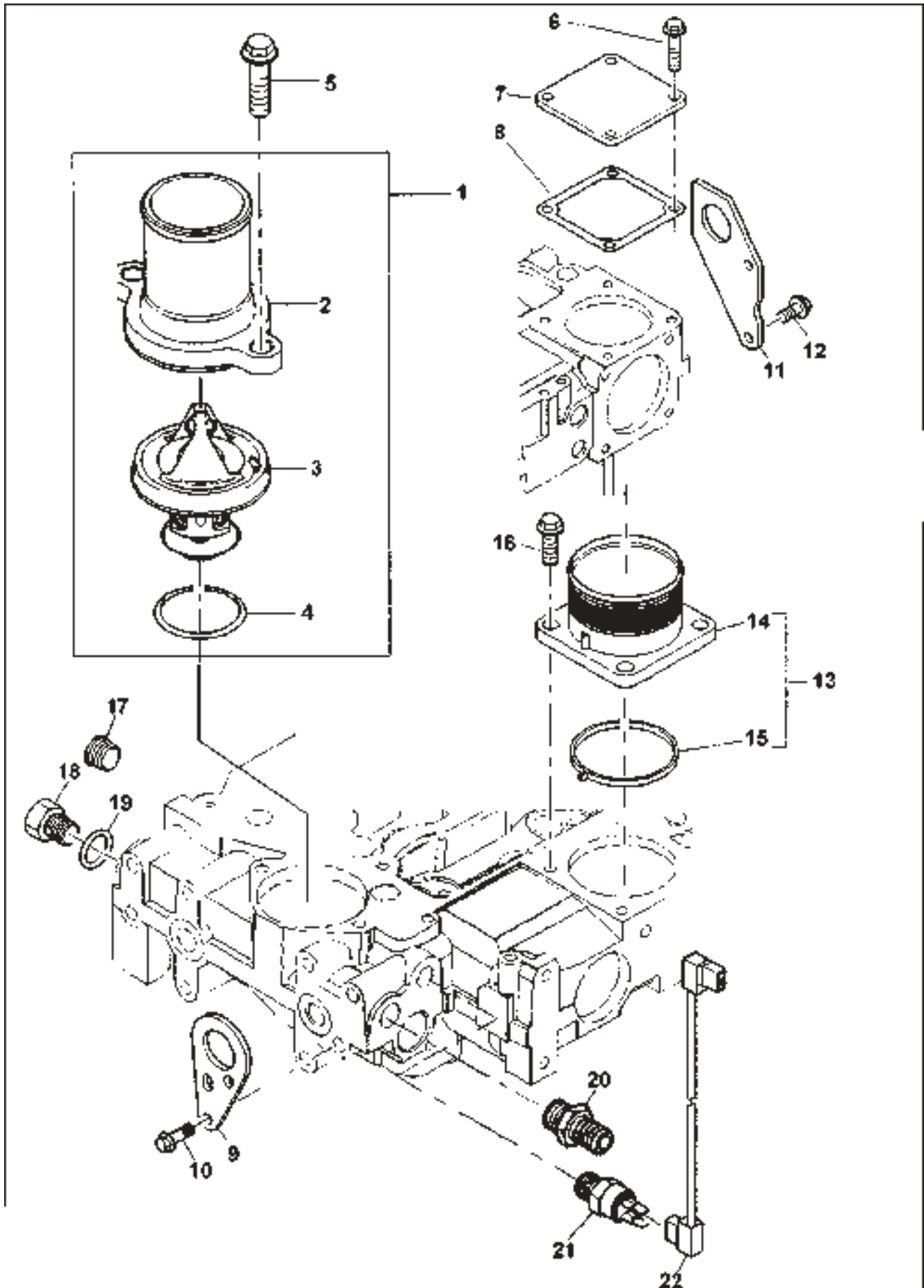

ITEM No.	PART NO.	DESCRIPTION	QTY	REMARKS
1	*4133L501	CONNECTION	1	NSS-1
2		CONNECTION	1	
3	*2485C041	THERMOSTAT	1	
4	*2415H008	O RING	1	
5	*2314H004	SCREW	2	
6	*2314H033	SCREW	12	
7	*3611M006	PLATE	3	
8	*3684N503	JOINT	3	
9	*3617A015	LIFTING BRACKET	1	
10	*2314J002	SCREW	2	
11	*3624A016	LIFTING BRACKET	1	NSS-13
12	*2314J002	SCREW	2	
13	*4148K007	CONNECTION	1	
14		CONNECTION	1	
15	*3682A013	INLET MANIFOLD JOIN	1	
16	*2314H034	SCREW	4	
17	*2431154	PLUG	1	
18	*3278A006	PLUG	1	
19	*2415H003	O RING	1	
20	*33552414	ADAPTOR	1	
21	*2848A127	SENDER	1	
22	*3161C018	CABLE	1	
* - REFER ABBREVIATIONS PAGE				

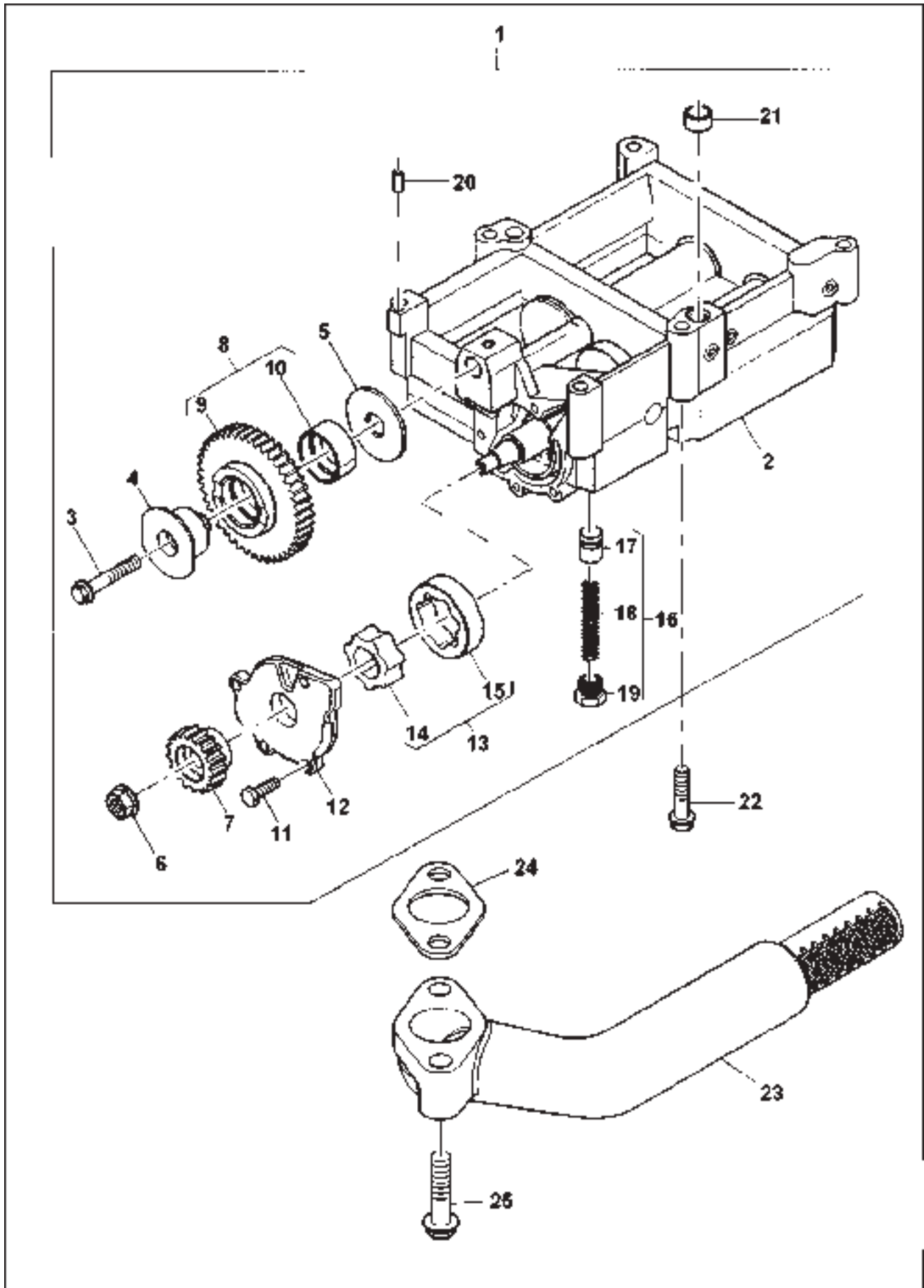

ITEM No.	PART NO.	DESCRIPTION	QTY	REMARKS
1	*4111K073	BALANCER	1	NSS-1
2		FRAME	1	
3	*2314H951	BOLT	1	
4	*3272A022	SHAFT	1	
5	*3321A006	THRUST WASHER	1	
6	*2318F605	NUT	1	NSS-8
7	*3117A101	BALANCER GEAR	1	
8	*4111A029	BALANCER GEAR	1	
9		GEAR	1	
10	*3112D031	BEARING	1	
11	*2314C945	SCREW	5	NSS-13 NSS-13
12	*3753R351	COVER	1	
13	*4111K068	ROTOR	1	
14		ROTOR	1	
15		ROTOR	1	
16	*U5MK0695	RELIEF VALVE	1	
17	*324A002	CONTACT	1	
18	*3174A021	SPRING	1	
19	*3218A013	PLUG	1	
20	*3244A013	DOWEL	1	
21	*33137409	THIMBLE	1	
22	*2314J012	SCREW	6	
23	*3765A091	SUCTION PIPE	1	
24	*3682137	JOINT	1	
25	*2314H006	SCREW	2	
* - REFER ABBREVIATIONS PAGE				

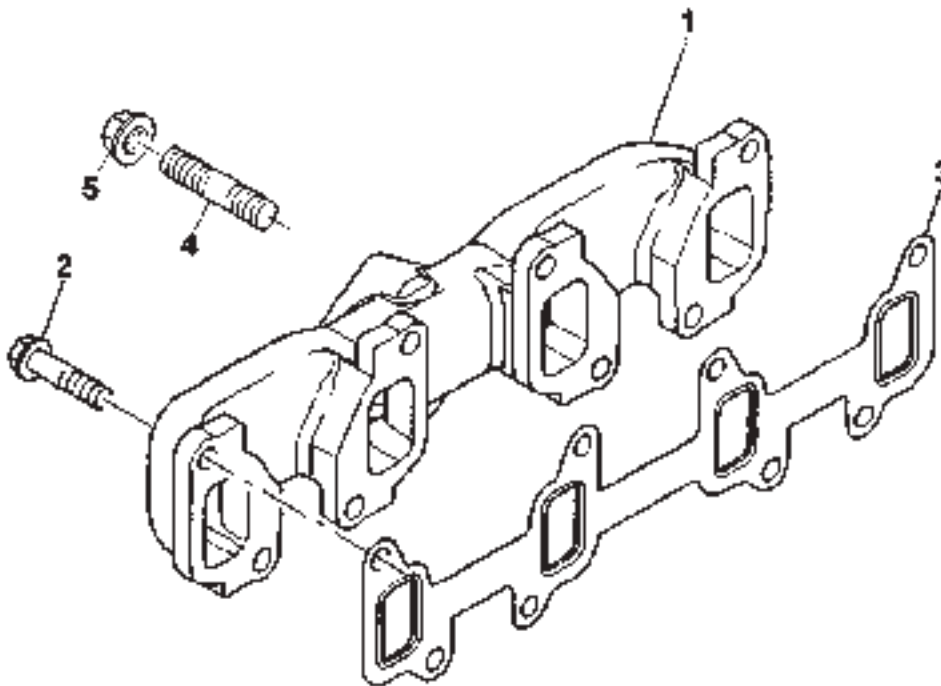

ITEM No.	PART NO.	DESCRIPTION	QTY	REMARKS
1	*3778E232	EXHAUST MANIFOLD	1	
2	*3218J013	SCREW	8	
3	*3681V512	EXHAUST MANIFOLD JOINT	1	
4	*2313C077	STUD	3	
5	*2318A634	NUT	3	
		* - REFER ABBREVIATIONS PAGE		

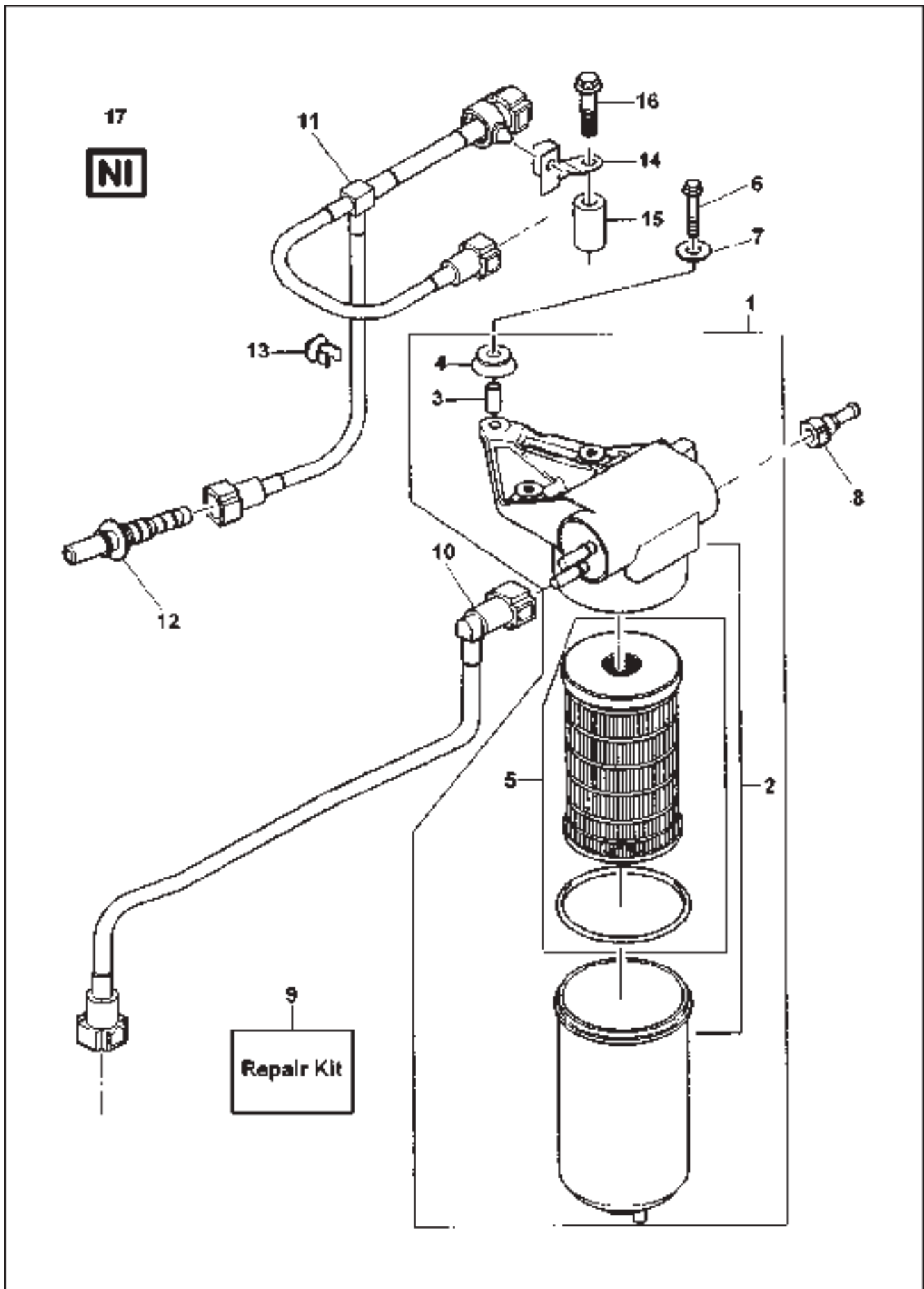

ITEM No.	PART NO.	DESCRIPTION	QTY	REMARKS
1	*4132A008	LIFT PUMP	1	
2		LIFT PUMP	1	NSS-1
3		SPACER	3	NSS-9
4		MOUNTING	3	NSS-9
5	*26560201	FUEL FILTER ELEMENT KIT	1	
6	*2314F909	SCREW	3	
7	*2131A507	WASHER	3	
8	*3763A046	CONNECTION	1	
9	*U5MK0696	MOUNTING KIT	1	
10	*2646F003	FUEL FEED PIPE	1	
11	*2646F004	FUEL FEED PIPE	1	
12	*3763A045	CONNECTION	1	
13	*2481D456	CLIP	1	
14	*3733A008	BRACKET	1	
15	*3313A006	SPACER	1	
16	*2314H008	SCREW	1	
		* - REFER ABBREVIATIONS PAGE		

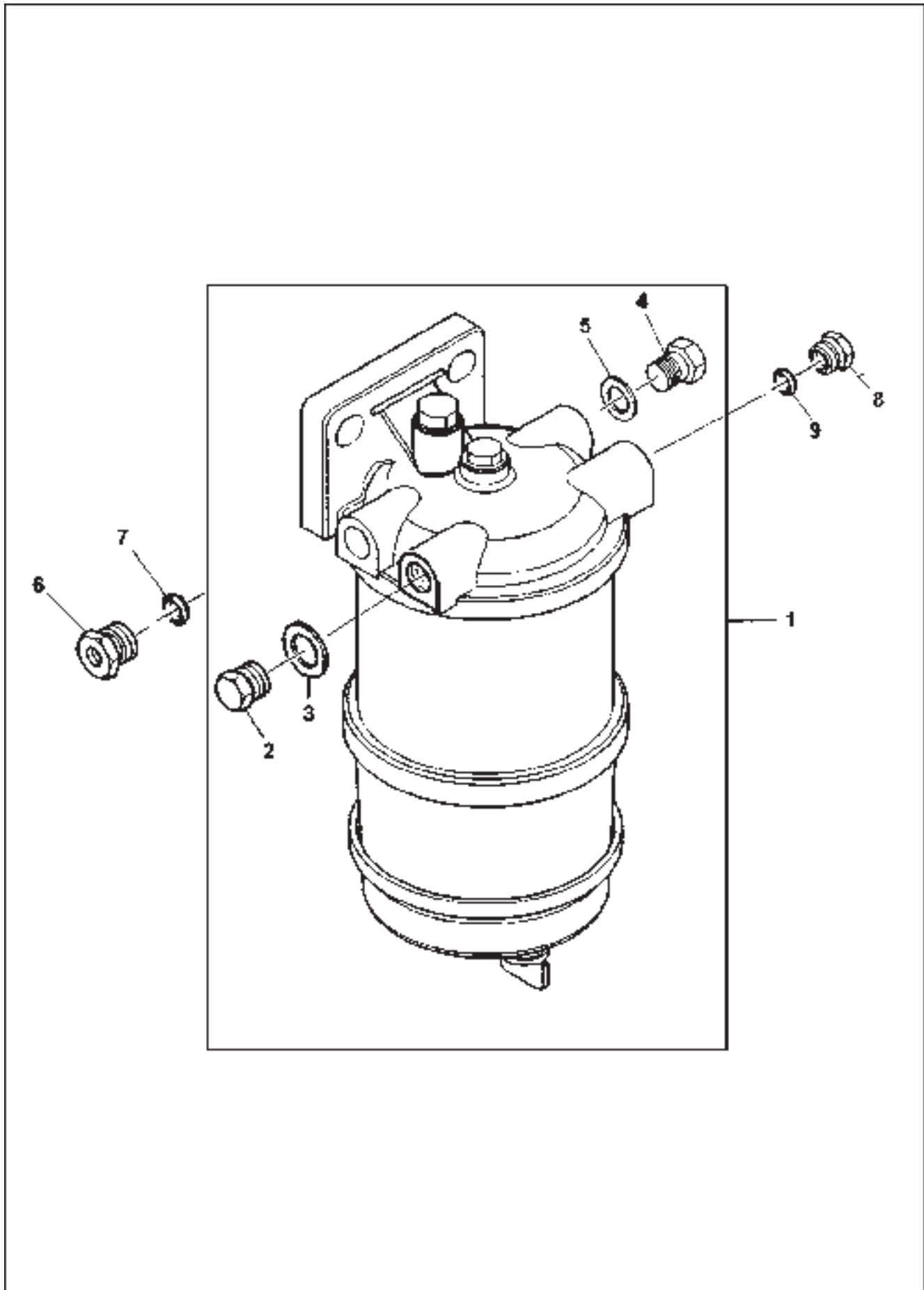

ITEM No.	PART NO.	DESCRIPTION	QTY	REMARKS
1	*2656F823	FUEL FILTER	1	
2	*0650204	PLUG	1	
3	*2411D013	PLAIN WASHER	1	
4	*0650204	PLUG	1	
5	*2411D013	PLAIN WASHER	1	
6	*33532129	NUT	1	
7	*0566004	OLIVE	1	
8	*33532129	NUT	1	
9	*0566004	OLIVE	1	
* - REFER ABBREVIATIONS PAGE				

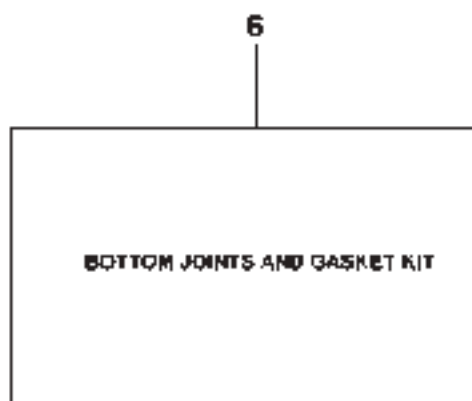
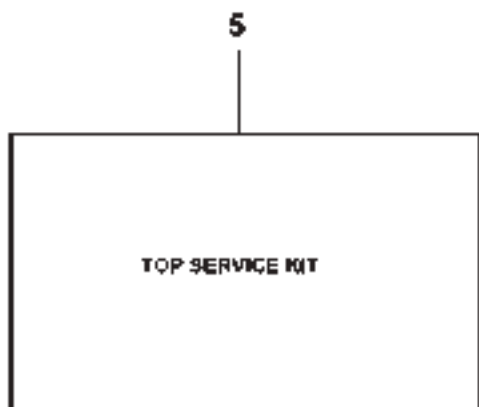
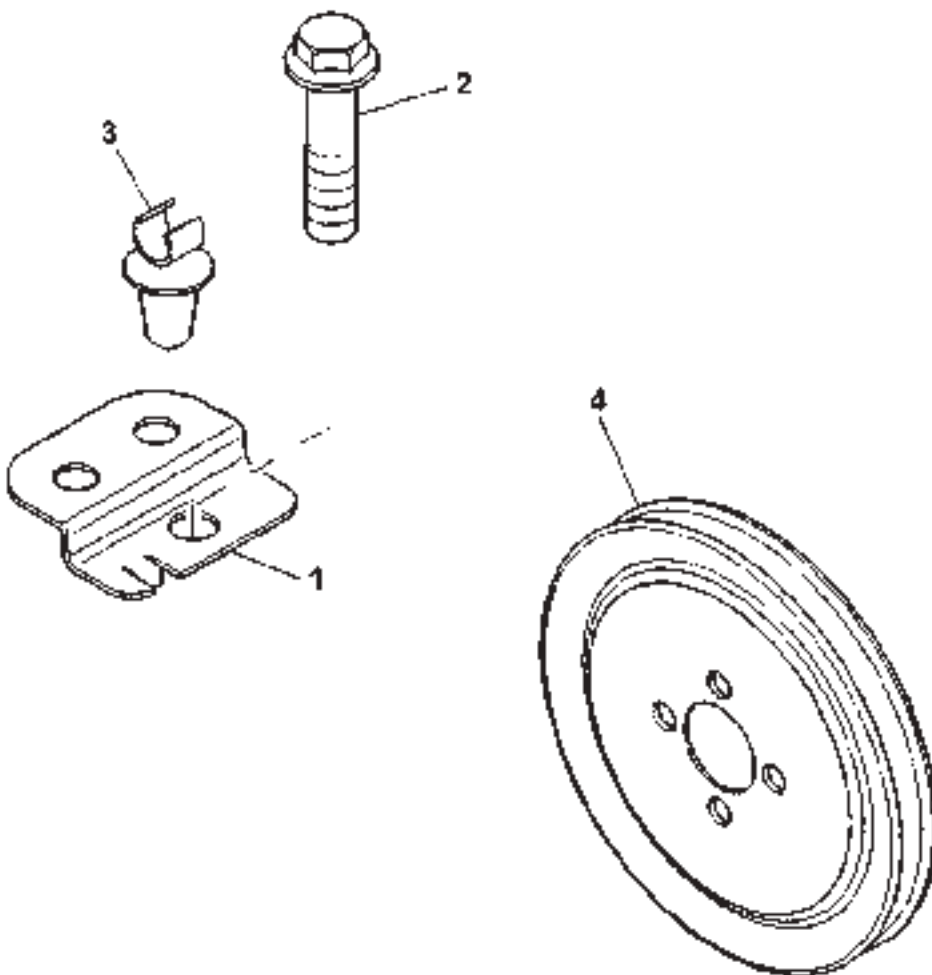

ITEM No.	PART NO.	DESCRIPTION	QTY	REMARKS
1	*3651A016	SUPPORT BRACKET	1	
2	*2314H002	SCREW	1	
3	*2481D556	CLIP	1	
4	*3114X191	1 GROOVE PULLEY	1	
5	*U5LT0350	TOP JOINT AND GASKET KIT	1	
5a	*3681E046	CYLINDER HEAD GASKET	1	
6	*U5LB0377	BOTTOM JOINT AND GASKET	1	
6a	*3681K036	SUMP JOINT	1	
6b	*2415715	O RING	1	
6c	*36832137	JOINT	1	
6d	*3617V015	TIMING CASE JOINT	1	
6e	*3617V016	TIMING CASE JOINT	1	
6f	*3681P046	TIMING CASE COVER JOINT	1	
6g	*26420318	O RING	1	
6h	*3688A041	JOINT	1	
6i	*3688A039	JOINT	1	
6j	*3682A011	WATER PUMP JOINT	1	
6k	*3688A035	JOINT	1	
6l	*3685A024	JOINT	1	
6m	*3685A025	BOLT M8X20 HEX	4	
* - REFER ABBREVIATIONS PAGE				

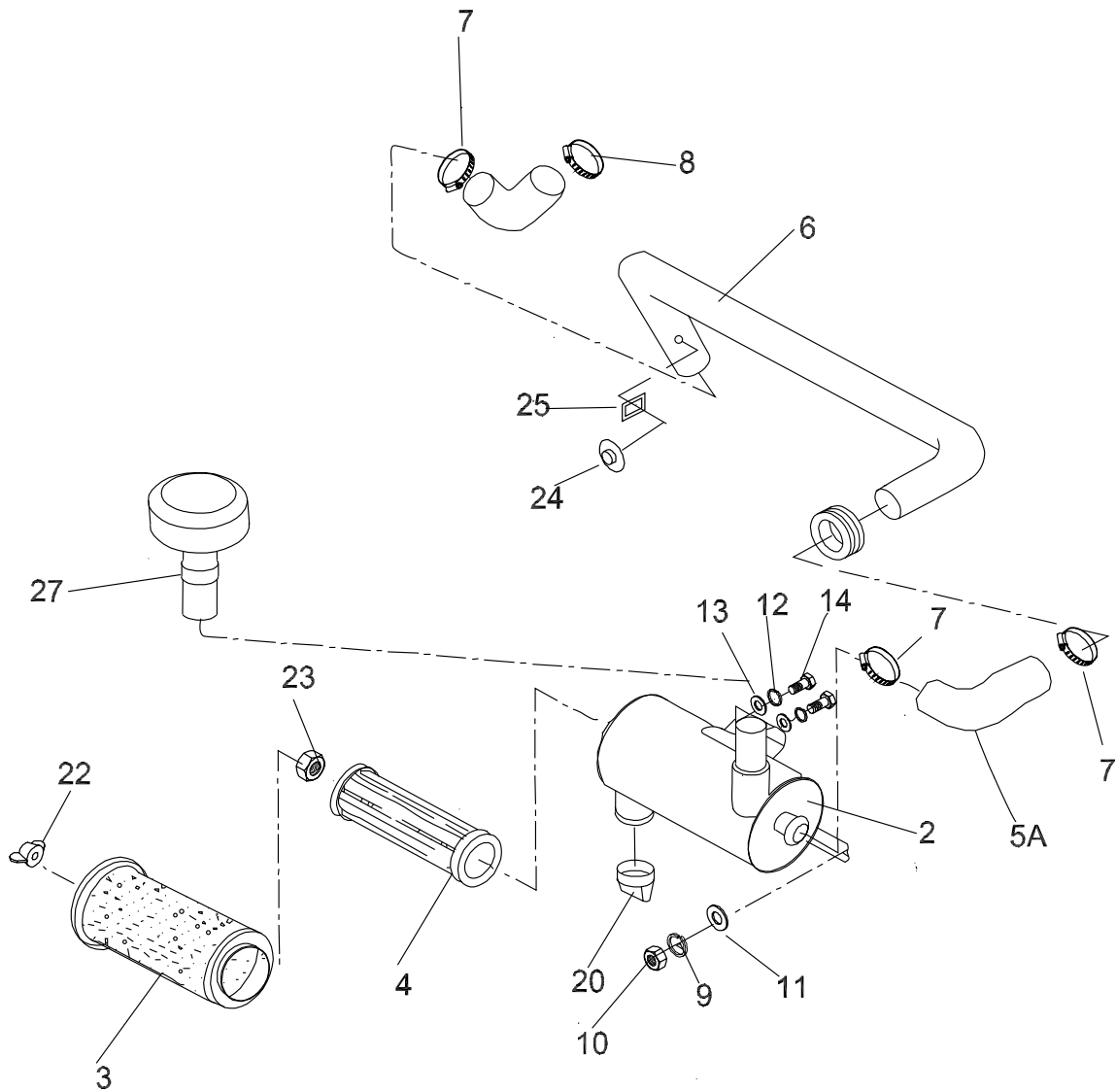

ITEM No.	PART NO.	DESCRIPTION	QTY	REMARKS
1	D10026730	CLEANER ASSY ENG AIR (DRY TYPE)	1	
2	-	HSG - DRY AIR CLEANER	1	
3	D10093670	ELEMENT PRIMARY FILTER	1	
4	D10102340	FILTER SECONDRY DRY AIR CLEANER	1	
5	D10026720	HOSE ENG AIR CLEANER OUTLET	1	
6	D10046420	HOSE AIR CLEANER TO INTAKE MANIFOLD FT80	1	
7	D10132820	TUBE ASSY ENG AIR CLEANER	3	
8	D10017630	CLAMP ASSY AIR CLEANER HOSE	1	
9	D10017170	CLAMP ASSY 70MM DIAMETER	2	
10	D86500090	WASHER M10 SPRING LOCK	1	
11	D83500210	NUT M10x1.50-5 HEX	1	
12	D85500140	WASHER M10 FLAT	1	
13	D86000010	WASHER 3/8" SPRING LOCK	2	
14	D85000010	WASHER 3/8" FLAT	2	
15	D81000150	BOLT 3/8"-16x0.75" HEX HEAD	2	
21	D10115740	CAP DUST DRY AIR CLEANER	1	
22	D83500210	NUT M10x1.50-5 HEX	1	
23	D10034130	NUT M10x1.50 NYLOCK	1	
26	D10026760	GROMMET AIR CLEANER	1	
27	D10026740	CAP AND EXTENSION ASSY AIR CLEANER	1	

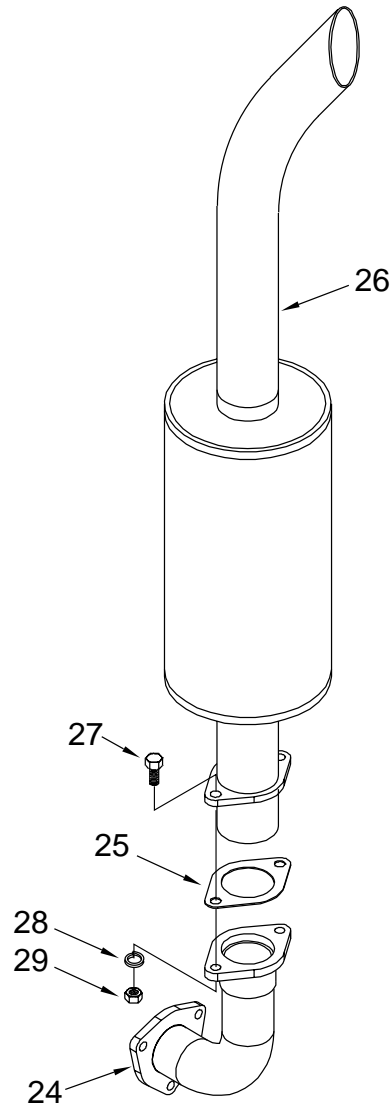

ITEM No.	PART NO.	DESCRIPTION	QTY	REMARKS
7	D10047470	ADAPTOR WATER TEMP GAUGE SENSOR	1	
8	D10011480	SENSOR UNIT WATER TEMP GAUGE	1	
24	D10117570	ELBOW EXH MANIFOLD FT80 (TIER II)	1	
25	D10046940	GASKET MUFFLER	1	
26	D10046050	MUFFLER ASSY VERTICAL-FT80	1	
27	D81500370	BOLT M10x1.50x30-6G HEX HEAD	2	
28	D86500090	WASHER M10 SPRING LOCK	2	
29	D83500210	NUT M10x1.50-5 HEX	2	

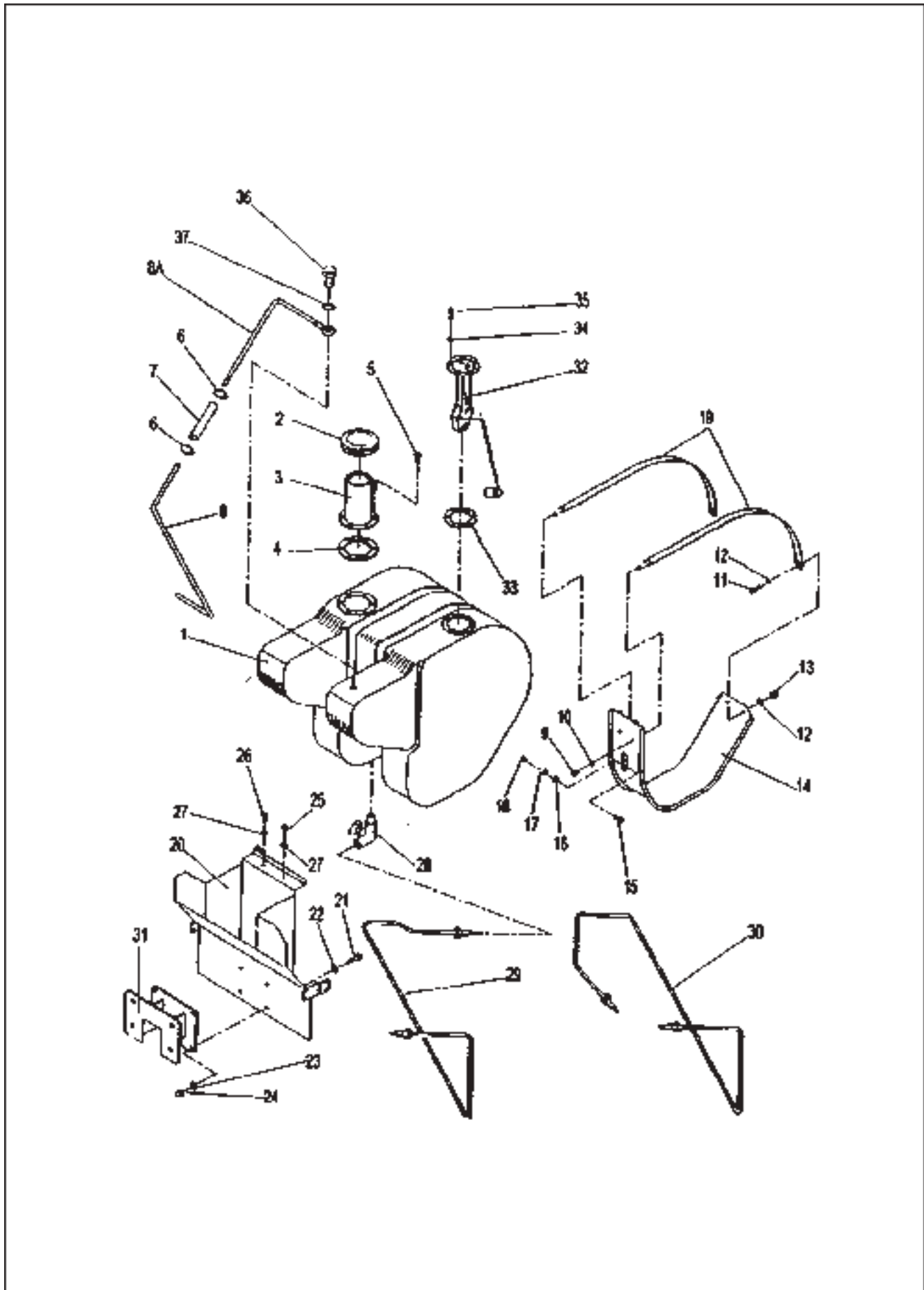

ITEM No.	PART NO.	DESCRIPTION	QTY	REMARKS
1	D10120520	TANK ASSY FUEL PLASTIC (FT80 SIMPSON ENG)	1	
2	D10026020	CAP ASSY FUEL TANK	1	
3	D10046310	FLANGE ASSY FUEL TANK FT80	1	
4	D10046430	GASKET FUEL TANK NECK FT80	2	
5	D81500730	BOLT M4x0.7x10	8	
6	D10017460	CLAMP ASSY FUEL TUBE	2	
8	D10131870	TUBE ENG OVERFLOW	1	
9	D83500210	NUT M10x1.50-5 HEX	4	
10	D85500140	WASHER M10 FLAT	4	
11	D81000140	BOLT 5/16"-18x0.88" HEX HEAD	2	
12	D85000040	WASHER 5/16" FLAT	4	
13	D10019410	NUT 5/16"-24 HEX	2	
14	D10045970	BRACKET TANK HOLDING	1	
15	D81000610	BOLT 5/16"-18x0.625" HEX HEAD	2	
16	D85000040	WASHER 5/16" FLAT	2	
17	D86000110	WASHER 5/16" LOCK EXTERNAL TOOTH	2	
18	D83000060	NUT 5/16"-18 HEX	2	
19	D10046290	BELT FUEL TANK HOLDING	2	
20	D10116140	BRACKET FUEL TANK SHIELD	1	
21	D81500280	BOLT M10x1.50x25-6G HEX HEAD	6	
22	D85500140	WASHER M10 FLAT	6	
23	D86500090	WASHER M10 SPRING LOCK	4	
24	D83500210	NUT M10x1.50-5 HEX	4	
25	D82000080	SCREW #10-24x1.25" HEX HEAD	1	
26	D10039900	SCREW 1/4"-28x1.50" PAN HEAD	1	
27	D85000030	WASHER 1/4" FLAT	2	
28	D10114590	COCK ASSY FUEL CONTROL	1	
29	D10131860	TUBE ASSY FUEL COCK ASSY TO FILTER	1	
31	D10116150	SHIELD BRACKET FUEL TANK	1	
32	D10047590	FLOAT ASSY FUEL TANK	1	
33	D10021980	GASKET FUEL TANK SENDER	1	
34	D10021990	WASHER FUEL TANK FLOAT	5	
35	D10026030	SCREW #10-32x0.625" HEX HEAD	5	
35a	D10026010	CLIP FUEL TANK SENSOR WIRE	1	
36	D10047580	BOLT HEX HEAD PIPE UNION	1	
37	D10017510	WASHER FIP LEAK OFF TUBE (TYPE 603)	2	
38	D10018360	SPACER FUEL TANK MNTG LWR	1	

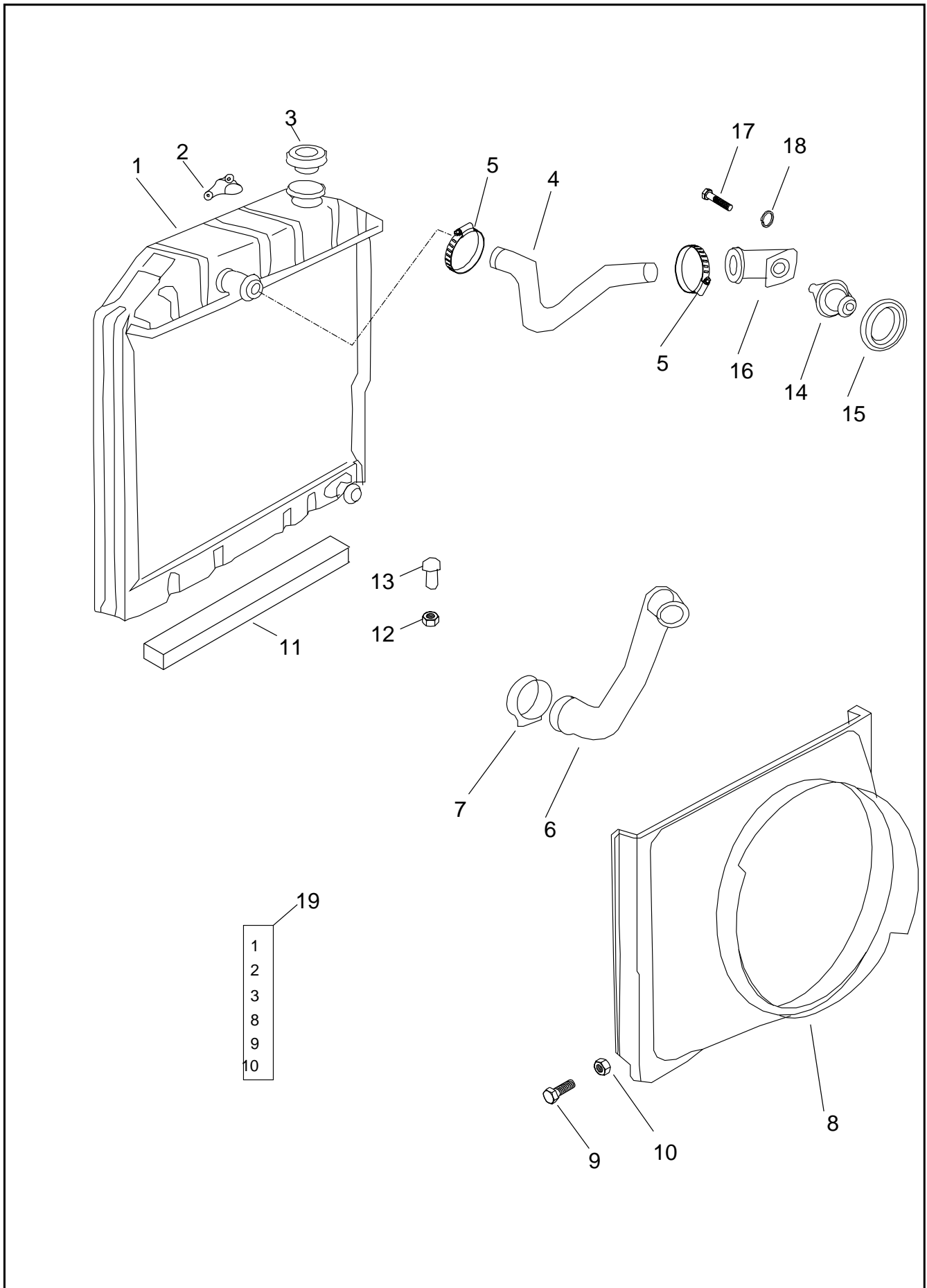

ITEM No.	PART NO.	DESCRIPTION	QTY	REMARKS
1	D10045780	RADIATOR ASSY	1	
2	D10062810	TAP ASSY RADIATOR DRAIN	1	
3	D10105080	CAP ASSY RADIATOR PRESSURE	1	
4	D10026240	HOSE RADIATOR UPR	1	
5	D10017540	HOSE CLAMP UPR	2	
6	D10026250	HOSE RADIATOR LWR	1	
7	D10017620	CLAMP RADIATOR HOSE LWR	2	
8	D10103760	SHROUD RADIATOR FAN	-	
9	D10107940	SCREW AND LOCK WASHER ASSY #8-32x3/8"	6	
10	D86500160	WASHER #8 FLAT	6	
11	D10018340	INSULATOR RADIATOR SUPPORT	2	
12	D10019060	NUT 7/16"-14 NYLOCK	2	NSS-1
13	D10017300	BOLT 7/16"-14x3.50" ROUND HEAD	2	
17	D81000640	BOLT 5/16"-18x1.125" HEX HEAD	2	
18	D86000040	WASHER 5/16" SPRING LOCK	2	

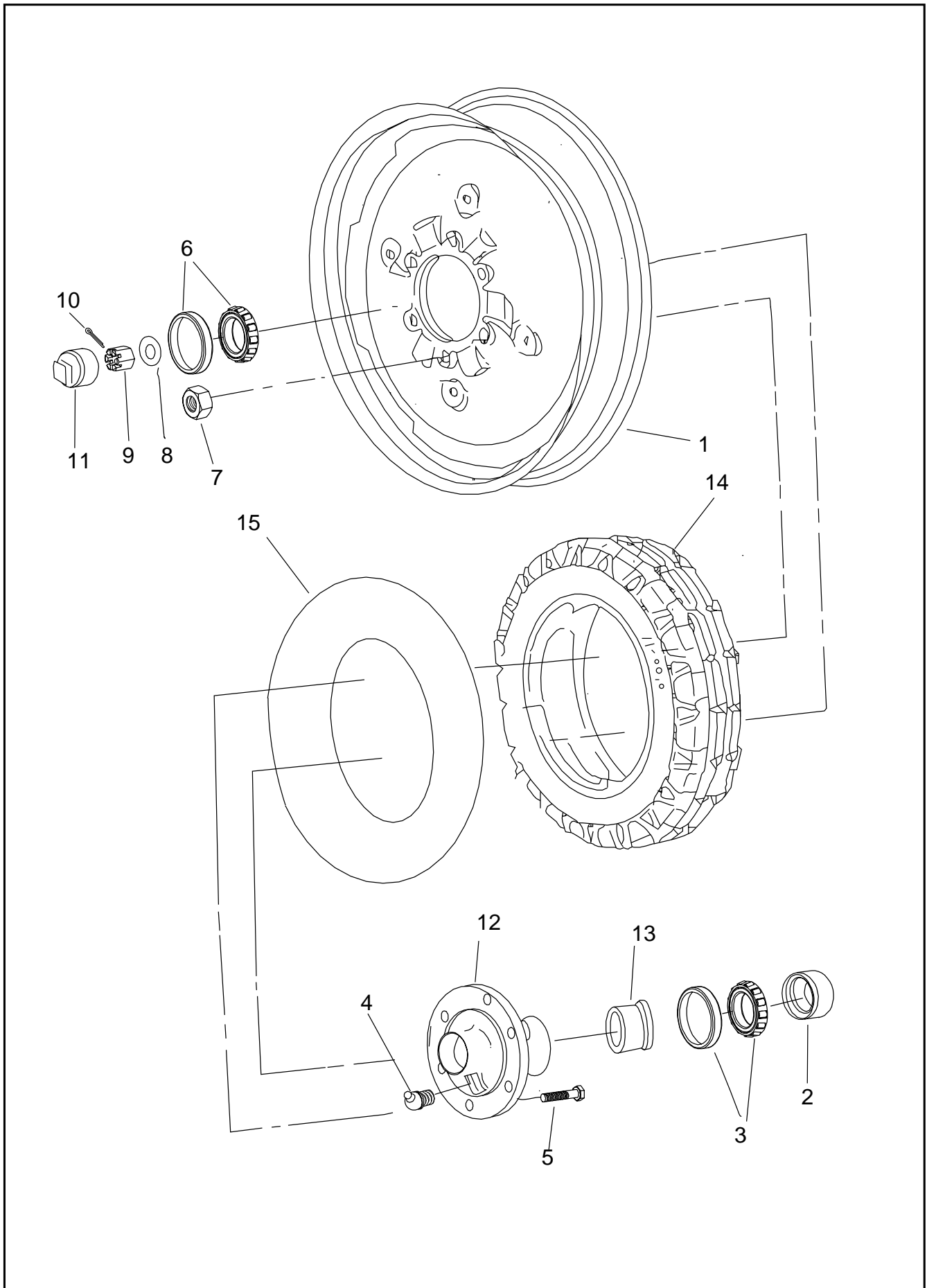

ITEM No.	PART NO.	DESCRIPTION	QTY	REMARKS
1	D10026220	WHL ASSY FRONT W/O PRIMER	2	
2	D10012700	SEAL FRONT AXLE HUB	2	
3	D10013290	BRG ASSY FRONT WHL INNER	2	
4	D92000020	GREASE NIPPLE 1/2"-27 STRAIGHT FITTING	2	
5	D10012000	BOLT FRONT WHL HUB	12	
6	D10012100	BRG ASSY FRONT WHL OUTER	2	
7	D10018200	NUT FRONT WHL BOLT	12	
8	D10012970	WASHER FRONT HUB BRG RETAINER	2	
9	D10012980	NUT 1"-12 SLOTTED HEX	2	
10	D88400080	PIN 5/32"x1.75" COTTER	2	
11	D10012960	CAP HUB GREASE	2	
12	D10012110	HUB FRONT WHL	2	
13	D10012060	BUSH FRONT WHL HUB	2	

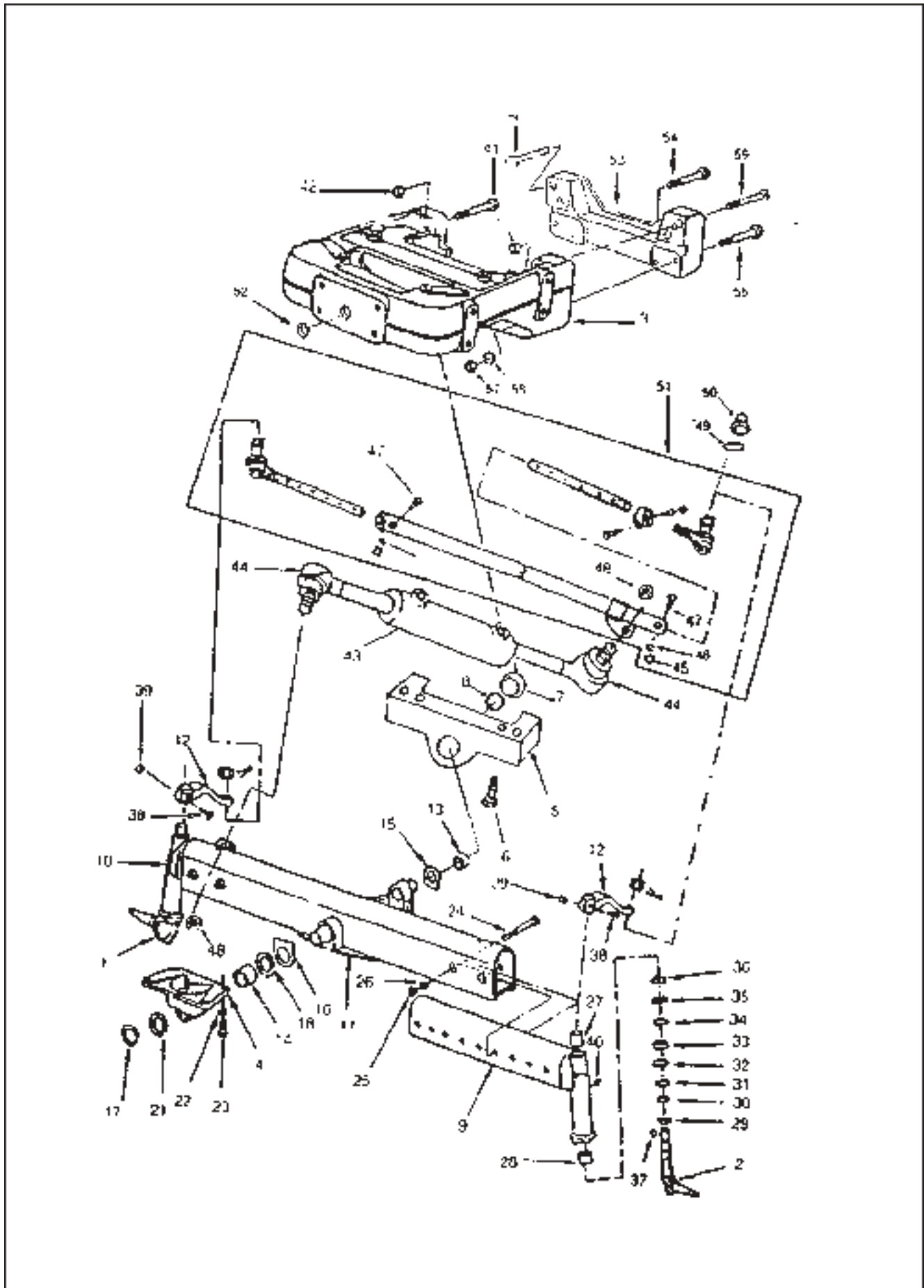

ITEM No.	PART NO.	DESCRIPTION	QTY	REMARKS
1	D10043630	SPINDLE ASSY FRONT AXLE RH	1	
2	D10043640	SPINDLE ASSY FRONT AXLE LH	1	
3	D10045840	SUPPORT FRONT AXLE	1	
4	D10039790	BRACKET FRONT AXLE TRUNION	1	
5	D10042780	BRACKET FRONT AXLE TRUNION REAR	1	
6	D10012670	BOLT TRUNION BRACKET MNTG	2	
7	D10042560	PLUG AND NUT ASSY TRUNION REAR	1	
8	D10042660	CIRCLIP TRUNION REAR	1	
9	D10039510	AXLE FRONT LH	1	
10	D10039520	AXLE FRONT RH	1	
11	D10039310	AXLE FRONT CENTRE	1	
12	D10042540	ARM STRNG SPINDLE FRONT AXLE	2	
13	D10021330	BUSH FRONT AXLE SUPPORT	1	
14	D10021360	BUSH BRACKET FRONT AXLE TRUNION	1	
15	D10021400	WASHER FRONT AXLE THRUST REAR	1	
16	D10021410	WASHER FRONT AXLE THRUST FRONT	1	
17	D10021370	PLUG FRONT AXLE TRUNION POWER STRNG	1	
18	D10021430	SHIM FRONT AXLE CENTRE POWER STRNG (0.015")	AR	
19	D10021420	SHIM FRONT AXLE CENTRE POWER STRNG (0.005")	AR	NI,
20	D10021420	SHIM FRONT AXLE CENTRE POWER STRNG (0.005")	AR	NI,
21	D10021380	CIRCLIP TRUNION POWER STRNG	1	
22	D10003580	WASHER 1/2" FLAT	4	
23	D81000610	BOLT 5/16"-18x0.625" HEX HEAD	4	
24	D81000940	BOLT 5/8"-11x4.50" HEX HEAD	4	
25	D83000090	NUT 5/8"-11 HEX	4	
26	D10103070	SPACER FRONT AXLE	4	
27	D10042920	BUSHING FRONT AXLE	2	
28	D10012300	BUSHING FRONT WHL SPINDLE PIN LWR	2	
29	D10042940	CVR SEAL DUST UPR	2	
30	D10042930	SPACER FRONT WHL SPINDLE	2	
31	D10042900	SEAL O RING FRONT SPINDLE	2	
32	D10042910	SEAL ASSY LWR FRONT AXLE SPINDLE	2	
33	D10039800	BRG SPINDLE FRONT AXLE (51108)	2	
34	D10012810	SEAL FRONT AXLE SPINDLE UPR	2	
35	D10012850	CVR FRONT AXLE SPINDLE SEAL DUST UPR	2	
36	D10012310	SEAL SPINDLE FRONT AXLE UPR	2	
37	D91000070	KEY 1/4"x7/8" WOODRUFF	2	
38	D81000490	BOLT 7/16"-14x2.25" HEX HEAD	2	
39	D83000040	NUT 7/16"-14HEX	2	
40	D92000020	GREASE NIPPLE 1/2"-27 STRAIGHT FITTING	2	
41	D81000410	BOLT 3/4"-10x4.00" HEX HEAD	4	
42	D83000070	NUT 3/4"-10 HEX	4	
43	D10021090	CYLINDER ASSY POWER STRNG	1	
44	D10021100	END ASSY CYLINDER POWER STRNG	2	
45	D83500220	NUT M6x1.00-5 HEX	2	
46	D85500110	WASHER M6 FLAT	2	
47	D82500050	SCREW M6x1.00x12-6.8 HEX HEAD	2	
48	D10021110	NUT M18x1.50 LOCK	2	
49	D10105490	RING RETAINING	4	
50	D10105100	CAP STRNG DRAG LINK END DUST	4	

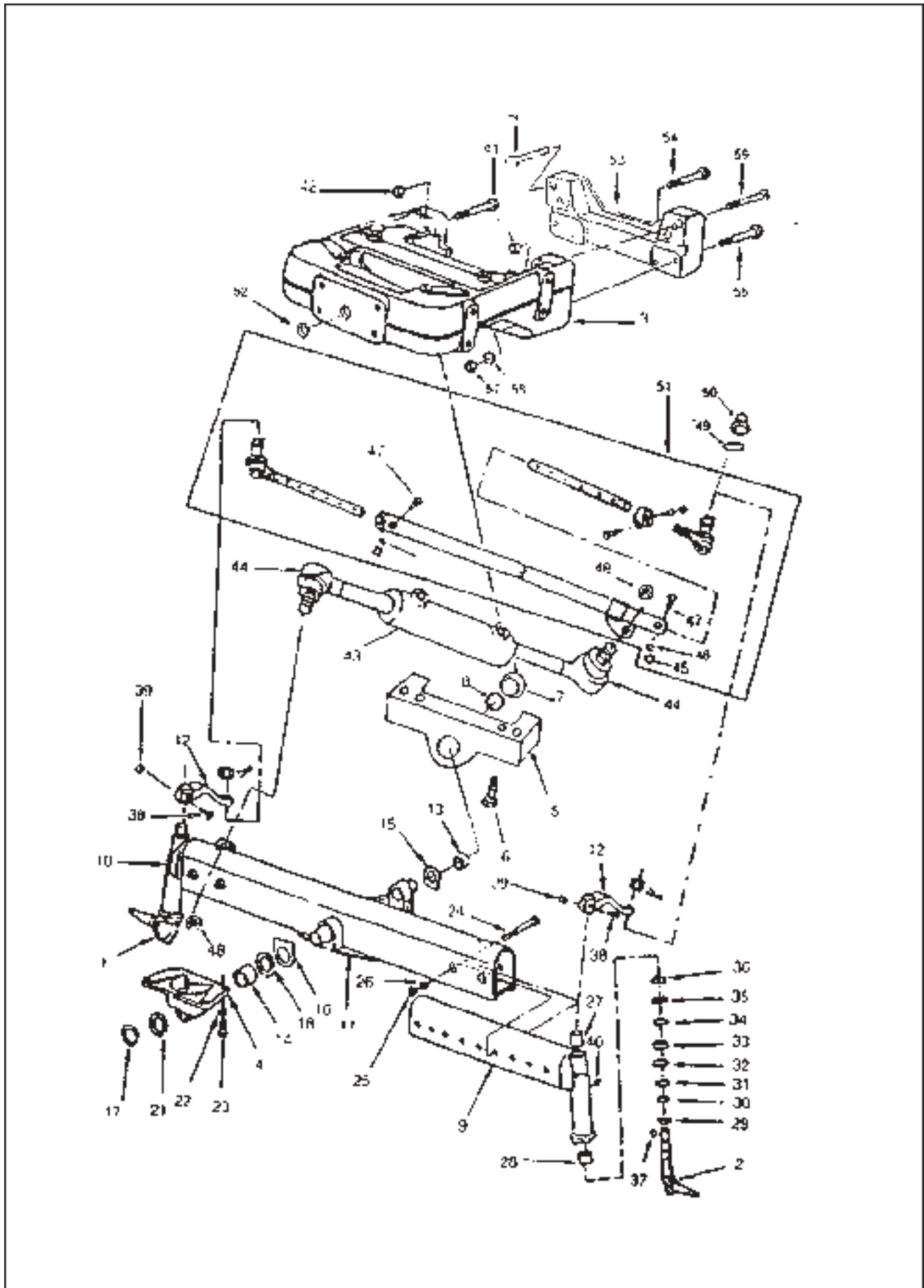

ITEM No.	PART NO.	DESCRIPTION	QTY	REMARKS
51	D10039330	LINK ASSY STRNG DRAG	1	
52	D10019450	PLUG DUST FRONT SUPPORT	1	
53	D10046130	ADOPTER FRONT AXLE FT80	1	
54	D10046840	BOLT M16x2.0x75	2	
55	D10046850	BOLT M16x2.0x95	2	
56	D10046860	BOLT M16x2.0x125	4	
57	D83500270	NUT M16x2.00-5 HEX	4	
58	D86500120	WASHER M16 SPRING LOCK	8	
59	D10047800	BOLT M16x2.00x130 HEAX HEAD	2	
60	D83000070	NUT 3/4"-10 HEX	2	
61	D81000410	BOLT 3/4"-10x4.00" HEX HEAD	2	
62	D10017820	CVR DUST 3/4"	24	
63	D10017830	CVR DUST 7/16"	6	NI,

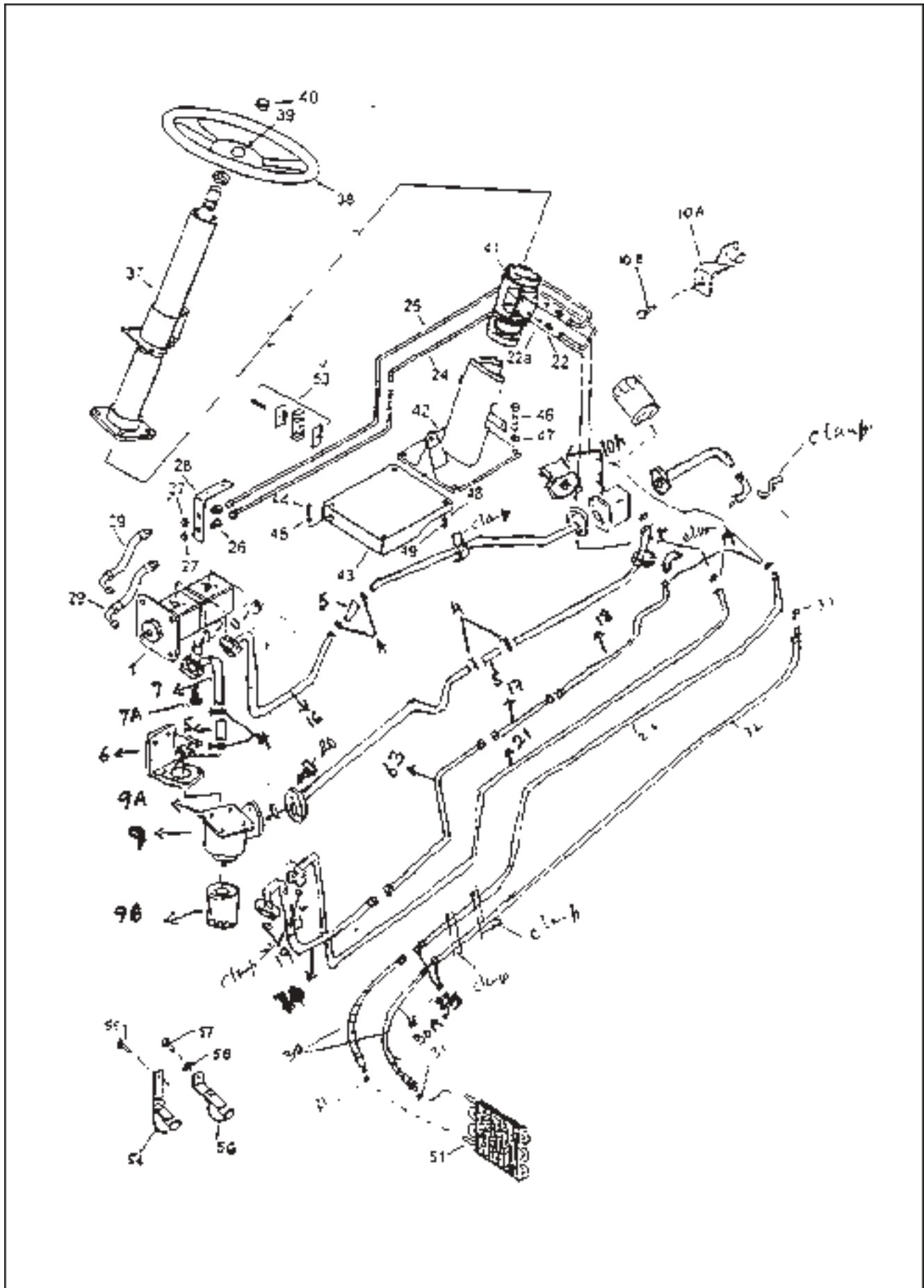

ITEM No.	PART NO.	DESCRIPTION	QTY	REMARKS
1	D10047250	PUMP ASSY HYD LIFT OIL (FT80US)	1	
2	D93600150	SEAL O RING 0.103"x0.937"	1	
3	D93600140	SEAL O RING 0.070"x0.656"	1	
4	D10131750	CLAMP HYD PUMP	2	
5	D10124600	HOSE HYD LIFT OIL	3	
5a	D81500490	BOLT M6x1.0x20-6G HEX HEAD	2	
6	D10131710	BRACKET ASSY HYD PUMP FILTER MNTG	1	
7	D10131730	TUBE ASSY HYD FILTER INL	1	
7a	D10046870	BOLT M8x1.25x45 SOCKET HEAD	2	
7e	D93600020	SEAL O RING 0.139"x1.250"	1	
7f	D81500560	BOLT M12x1.75x30-6G HEX HEAD	1	
7g	D10012190	GROMMET HYD PUMP INL PIPE	1	
7h	D10012210	GROMMET HYD PUMP INL PIPE	1	
8a	D10034950	SCREW M6x1.00x20-6.6 HEX HEAD	3	
9a	D10013260	ADAPTOR OIL FILTER	1	
9b	D10139860	FILTER ASSY HYD LIFT OIL INTAKE	1	
10a	D10012140	ADAPTER HYD OIL FILTER	1	
10b	D82500090	SCREW M12x1.75x25-6.6 HEX HEAD	1	
10c	D10016780	FILTER ASSY HYD LIFT OIL INTAKE	1	
15	D93600110	SEAL O RING 0.103"x0.437"	1	
16	D10131810	TUBE ASSY EXTENSION STRNG FILTER INL TO STRNG PUMP	1	
17	D10131770	TUBE ASSY HYD TAP OFF	1	
18	D10044230	TUBE ASSY SPOOL VALVE INL-CDS	1	
19	D93600110	SEAL O RING 0.103"x0.437"	1	
20	D10046870	BOLT M8x1.25x45 SOCKET HEAD	9	
21	D10131840	TUBE ASSY EXTENSION STRNG PUMP TO STRNG UNIT	1	
21a	D10131850	TUBE ASSY EXTENSION TO STRNG UNIT	1	
22	D10021160	CONNECTER 1/2" FLX 3/4"-16 STRAIGHT THREAD	2	
22a	D93600070	SEAL O RING 0.087"x0.644"	4	
23	D10046990	TUBE ASSY RETURN TO COOLER FT80-CDS	1	
24	D10047020	TUBE ASSY RIGHT TURN POWER STRNG FT80	1	
25	D10047010	TUBE ASSY LEFT TURN POWER STRNG FT80	1	
26	D10021280	ADAPTOR 9/16"-18 HIGH PRESSURE TUBE FITTING	2	
27	D10021270	NUT 9/16"-18 HEX	2	
28	D10046790	BRACKET HOSE TO OIL SUMP	1	
29	D10021130	HOSE ASSY POWER STRNG CYLINDER	2	
30	D10092550	HOSE TRANSMISSION OIL COOLER	1	
30a	D10092560	HOSE TRANSMISSION OIL COOLER RETURN	1	
31	D10017460	CLAMP ASSY FUEL TUBE	4	
32	D10047000	TUBE ASSY RETURN TO HSG FT80-CDS	1	
33	D10090900	ADAPTER 1/2" BSP OIL COOLER RETURN	1	
37	D10013170	HOSE HYD LIFT PUMP INL TUBE	1	
38	D10039690	WHL ASSY POWER STRNG	1	
39	D10016560	CAP STRNG WHL	1	
40	D10018500	NUT NYLOCK STRNG WHL RETAINING	1	
41	D10098750	STRNG MOTOR (O N TYPE)	1	
42	D10046760	BRACKET ASSY POWER STRNG MNTG	1	
43	D10046680	BRACKET STRNG MNTG EXTENSION	1	
44	D81500740	BOLT M14x2.0x35	4	
45	D86500110	WASHER M14 SPRING LOCK	4	

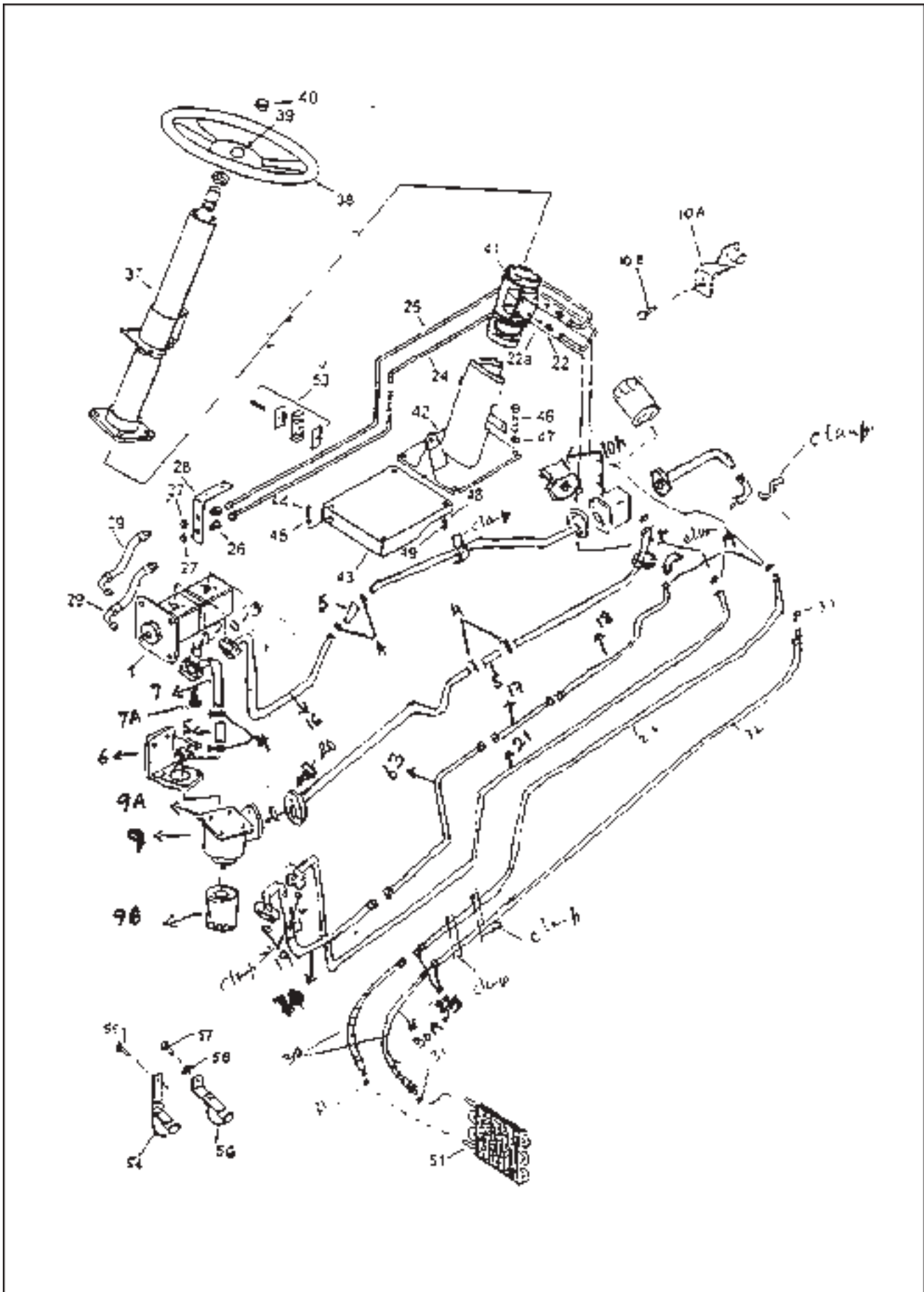

ITEM No.	PART NO.	DESCRIPTION	QTY	REMARKS
46	D81000350	BOLT 1/2"-13x1.75" HEX HEAD	4	
47	D10003580	WASHER 1/2" FLAT	4	
48	D86000060	WASHER 1/2" SPRING LOCK	4	
49	D83000050	NUT 1/2"-13 HEX	4	
51	D10039260	COOLER ASSY HYD OIL	1	
52	D10046780	PLATE	2	
52a	D10046260	PAD TUBING POWER STRNG	2	
52b	D10047080	PLATE TUBING POWER STRNG	2	
52c	D81500340	BOLT M6x1.00x35-6G HEX HEAD	4	
53	D10042690	CLAMP ASSY TUBING POWER STRNG	1	
54	D10084110	CLAMP ASSY TUBE FRONT	1	
55	D81500580	BOLT M14x2.00x25-6G HEX HEAD LOCK	1	
56	D10084120	CLAMP ASSY TUBE REAR	1	
57	D81500540	BOLT M12x1.75x40-6G HEX HEAD	1	
60	D10039720	ADAPTER RETURN	1	
61	D10100140	PLUG	1	
62	D10124600	HOSE HYD LIFT OIL	1	
63	D10131770	TUBE ASSY HYD TAP OFF	1	
64	D10021080	ADAPTOR 3/4" POWER STRNG	4	
65	D10021080	ADAPTOR 3/4" POWER STRNG	2	
66	D10046800	BRACKET TUBING POWER STRNG	1	
67	D10046810	BRACKET TUBING POWER STRNG	2	
68	D10021630	ADAPTOR 9/16"-18 HIGH PRESSURE TUBE FITTING	1	
69	D10047070	STRIP HYD CLAMP MNTG	1	
70	D10131760	TUBE ASSY OIL DELIVERY HYD PUMP TO TAP OFF	1	
71	D10042570	ELBOW HYD TUBE INL	1	
72	D10131740	TUBE EXTENSION ASSY HSG TO HYD FILTER	1	
73	D10131820	TUBE ASSY STRNG PUMP SUCTION	1	
74	D10131790	TUBE EXTENSION ASSY HSG TO STRNG FILTER	1	
75	D10135290	TUBE ASSY HYD FILTER TO HYD PUMP	1	

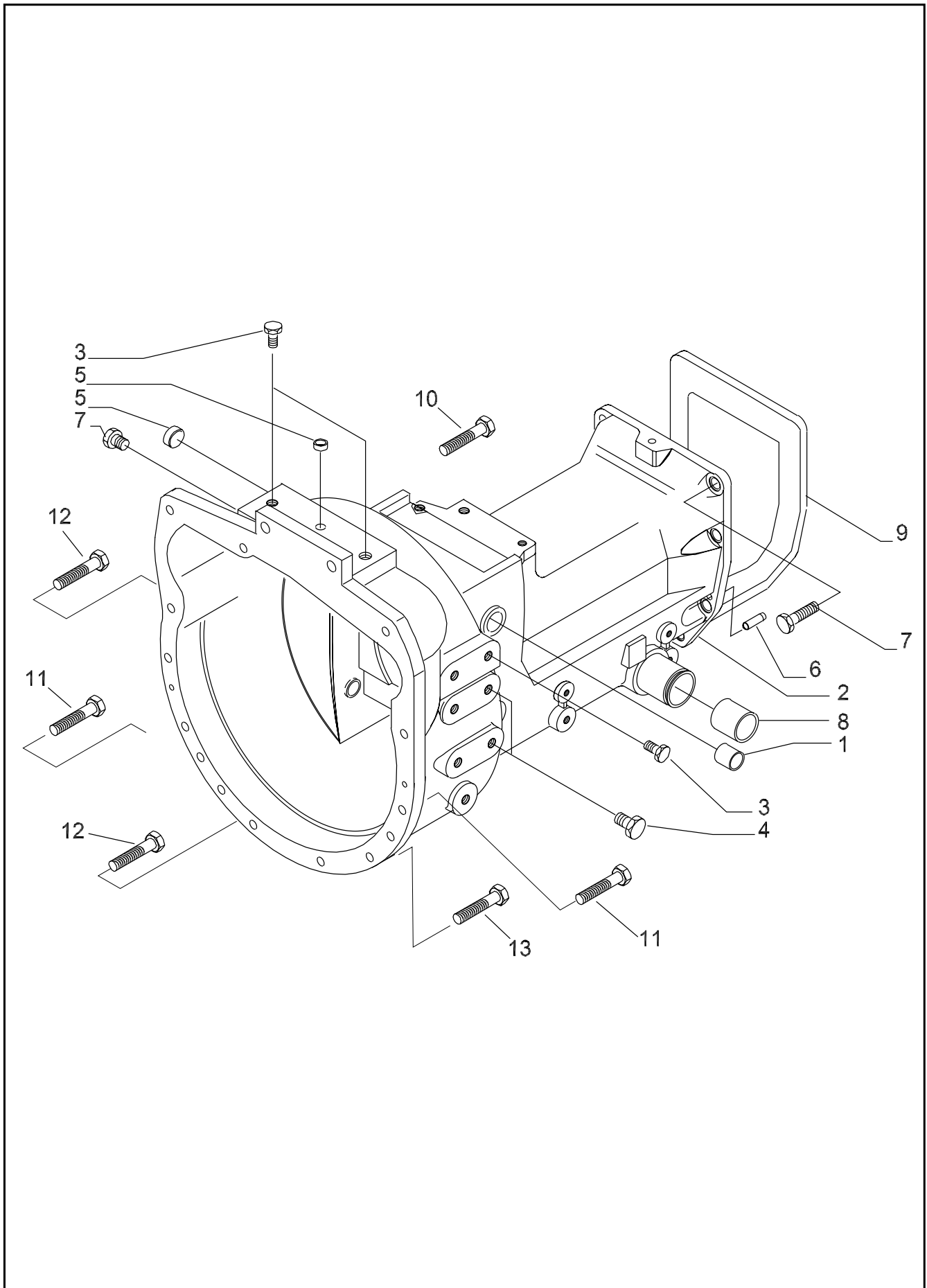

ITEM No.	PART NO.	DESCRIPTION	QTY	REMARKS
1	D10042950	BUSH CL RELEASE CONTROL SHAFT	4	
2	D10099000	HSG ASSY CL	1	
3	D81500580	BOLT M14x2.00x25-6G HEX HEAD LOCK	5	
4	D10042760	BOLT M16x2.00x35	4	
5	D10042960	PLUG CUP	2	
6	D10060850	PIN DOWEL	2	
7	D81500620	BOLT M14x2.00x45-6G HEX HEAD	8	
8	D10067010	BUSH CL PDL	2	
9	D10066360	GASKET CL HSG TO TRANSMISSION	1	
10	D81500680	BOLT M12x1.75x35	3	
11	D81500700	BOLT M12x1.75x60	5	
12	D81500690	BOLT M12x1.75x50	3	
13	D81500710	BOLT M12x1.75x75	4	

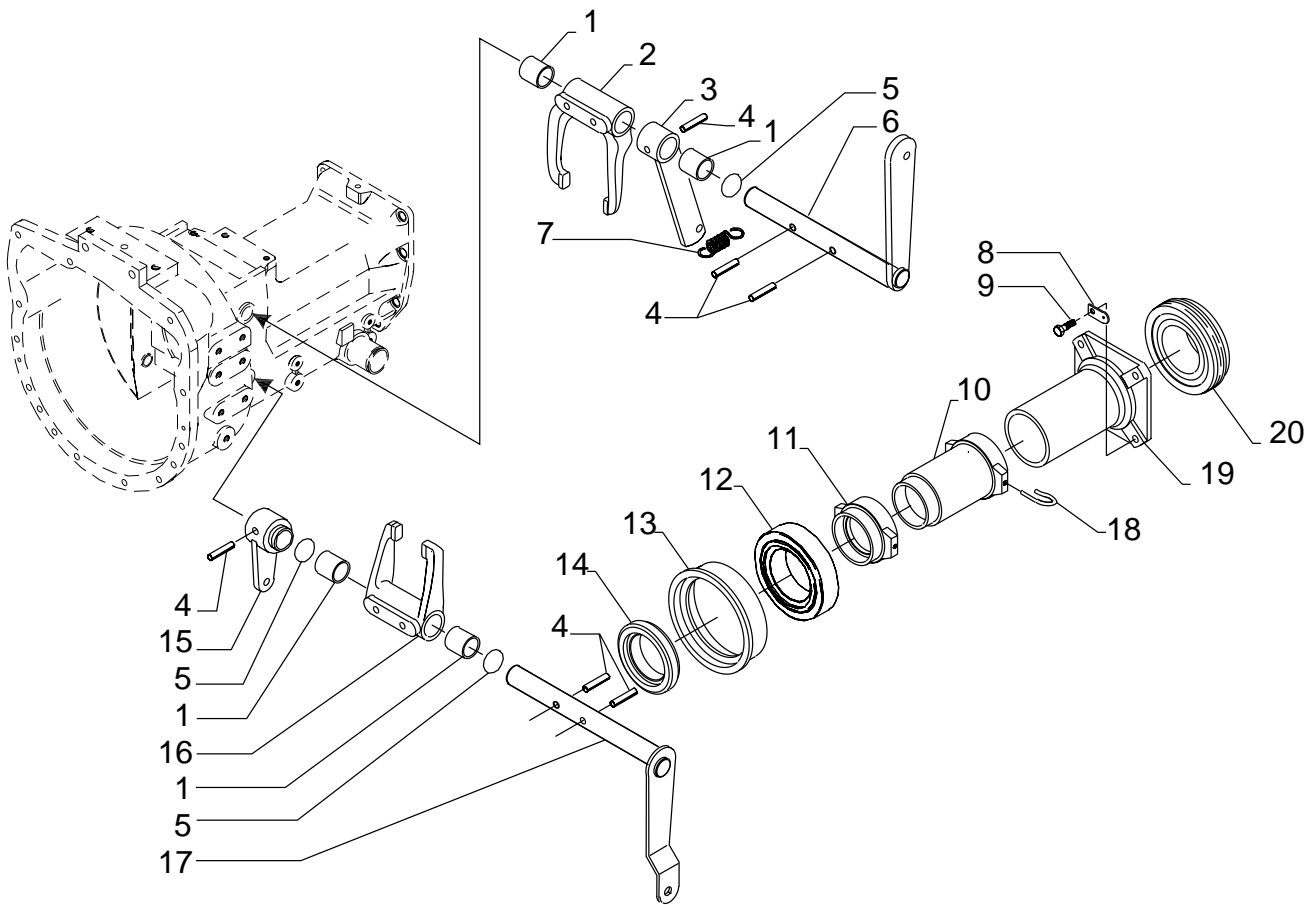

ITEM No.	PART NO.	DESCRIPTION	QTY	REMARKS
1	D10103790	BUSH CL RETURN PTO	4	
2	D10061210	FORK	1	
3	D10061180	LEVER	1	
4	D87000130	PIN 8x35 SPRING	4	
5	D10042990	SEAL O RING CL RELEASE SHAFT	3	
6	D10042870	SHAFT AND LEVER ASSY PTO CL RELEASE	1	
7	D10061150	SPRING	1	
8	D10103820	BRACKET SPRING RETAINING	1	
9	D81501370	BOLT M8x30 HEX HEAD	4	
10	D10061230	SLEEVE PTO	1	
11	D10061240	SLEEVE	1	
12	D10061270	BRG	1	
13	D10061260	SLEEVE	1	
14	D10061250	BRG	1	
15	D10063100	LEVER	1	
16	D10061200	FORK CL	1	
17	D10103810	SHAFT AND LEVER ASSY CL RELEASE(CIL 141206)	1	
18	D10061160	SPRING	4	
19	D10103800	RETAINER CL RELEASE	1	
20	D10061140	BRG 6308 2RS1(SKF)	1	
21	D10060850	PIN DOWEL	1	

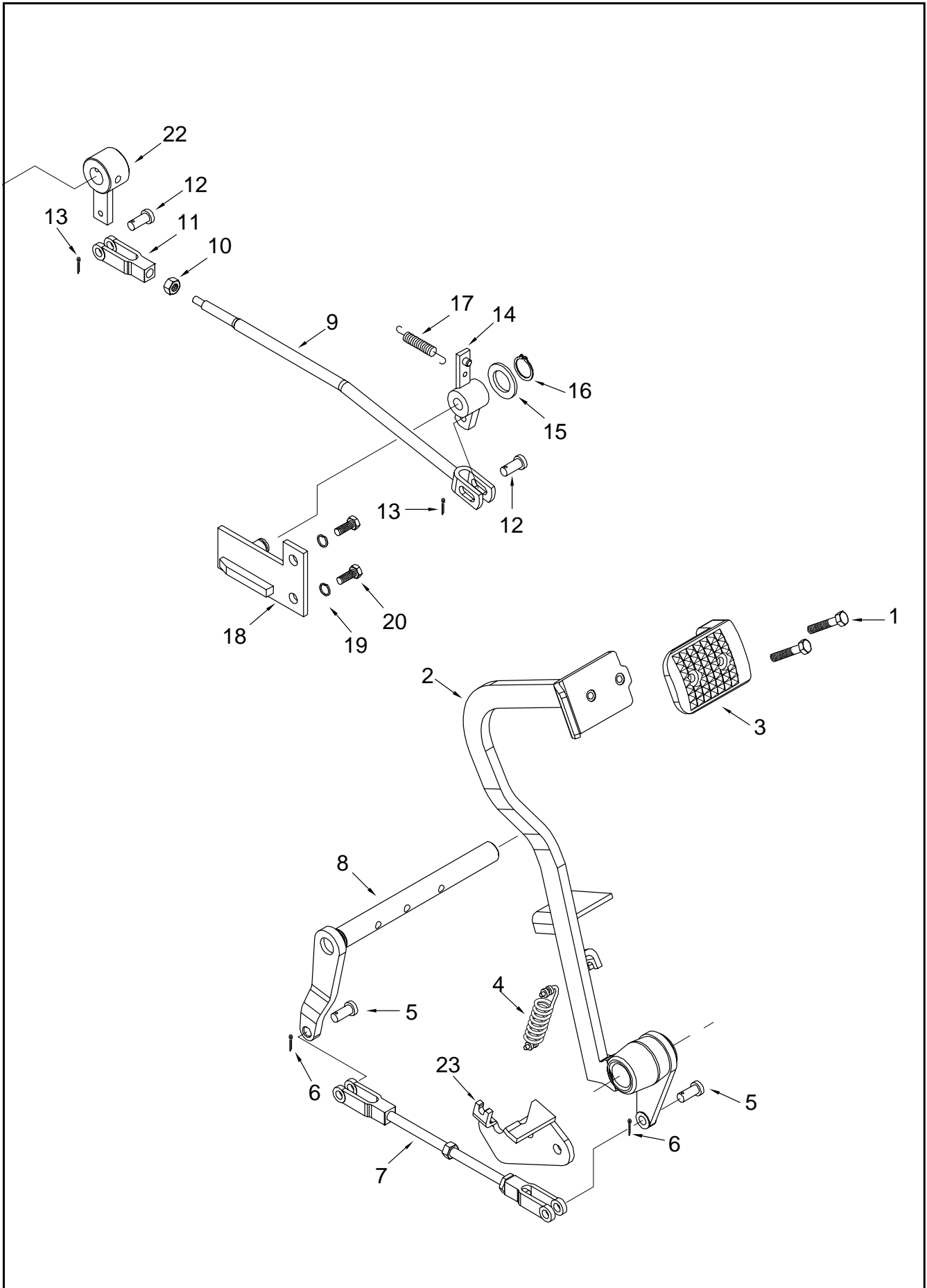

ITEM No.	PART NO.	DESCRIPTION	QTY	REMARKS
1	D81501020	BOLT M8x1.25x35-8.2 HEX HEAD	2	
2	D10046020	PDL ASSY CL	1	
2a	D10067010	BUSH CL PDL	1	NI,
2c	D10046750	SPACER CL PDL FT80	2	
3	D10042840	PAD PDL	1	
4	D10046920	SPRING CL PDL RETAINING FT80	1	
5	D93400070	PIN 10x27.5 CLEVIS	2	
6	D10013460	PIN 1/8"x0.75" COTTER	2	
7	D10047040	ROD AND CLEVIS ASSY CL RELEASE	1	
8	D10103810	SHAFT AND LEVER ASSY CL RELEASE(CIL 141206)	1	
9	D10046480	ROD FORWARD REVERSE LOCK	1	
10	D83500450	NUT M10x1.50 HEX	2	
11	D93400060	CLEVIS 10x47.62 ADJUSTABLE	1	
12	D93400070	PIN 10x27.5 CLEVIS	2	
13	D93400110	PIN 3.2x25.0 COTTER	2	
14	D10043370	HUB AND LEVER ASSY FORWARD REVERSE	1	
15	D10042730	WASHER THRUST	1	
16	D90000180	CIRCLIP A15x0.90 SB	1	
17	D10046920	SPRING CL PDL RETAINING FT80	1	
18	D10043390	BRACKET ASSY PIVOT	1	
19	D86000060	WASHER 1/2" SPRING LOCK	2	
20	D82500090	SCREW M12x1.75x25-6.6 HEX HEAD	2	
21	D92500050	GREASE NIPPLE 1/4"-28 STRAIGHT FITTING	1	
22	D10063100	LEVER	1	
23	D10046740	BRACKET CL PDL SPRING PIVOT REAR	1	
24	D81500610	BOLT M10x1.50x40-6G HEX HEAD	-	NI,
25	D85000050	WASHER 3/8" FLAT	1	NI,

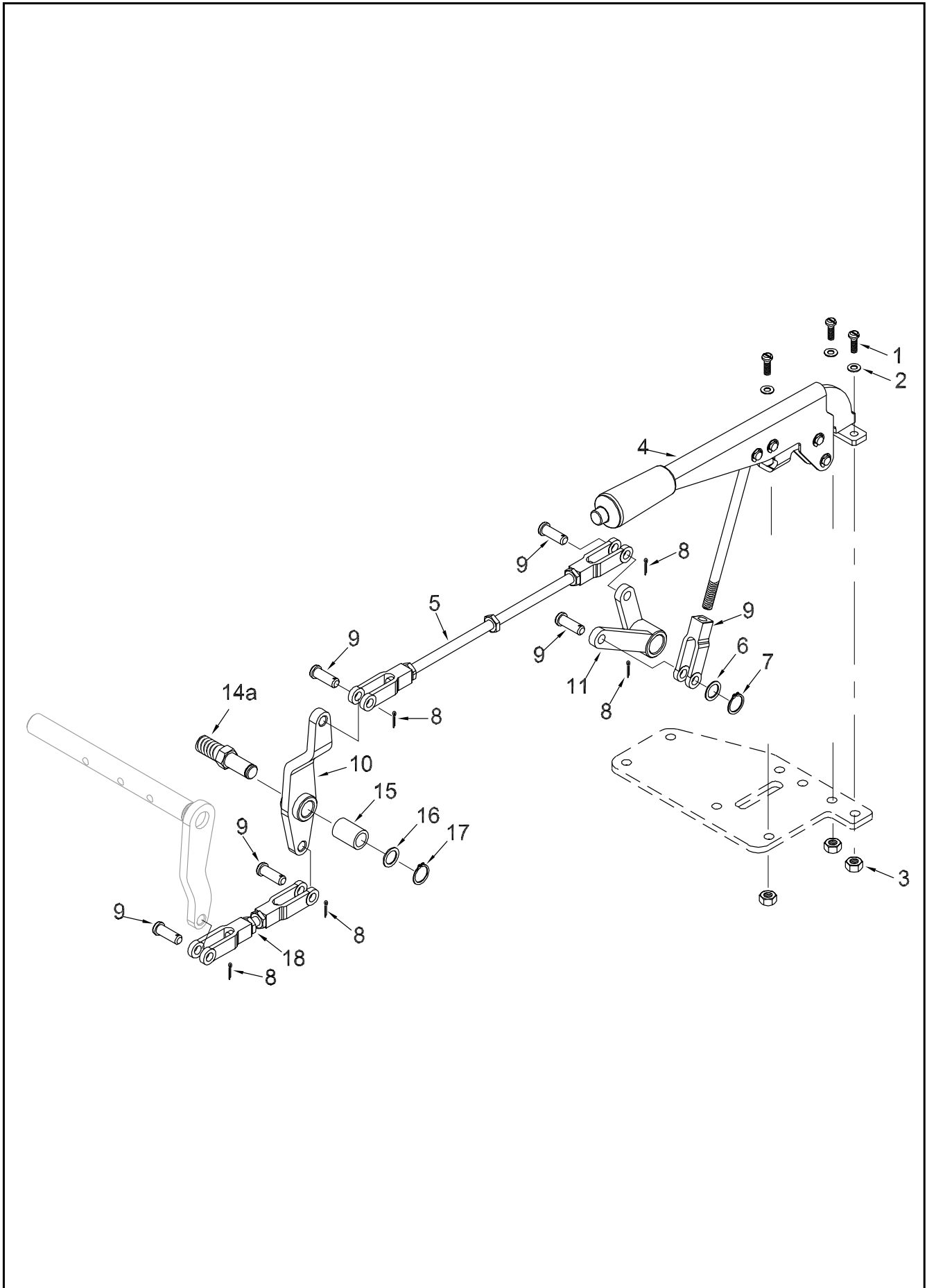

ITEM No.	PART NO.	DESCRIPTION	QTY	REMARKS
1	D81500490	BOLT M6x1.0x20-6G HEX HEAD	3	
2	D85500110	WASHER M6 FLAT	3	
3	D83500220	NUT M6x1.00-5 HEX	3	
4	D10039780	LEVER ASSY PTO CL	1	
5	D10047050	ROD CLEVIS ASSY PTO	1	
6	D10012260	WASHER BRK PDL CROSS SHAFT THRUST	1	
7	D10012470	RING CLUCH AND BRK CROSS SHAFT LOCK	1	
8	D10013460	PIN 1/8"x0.75" COTTER	5	
9	D93400030	PIN 3/8"x1.14" CLEVIS	5	
10	D10042890	HUB LEVER ASSY	1	
11	D10042250	SLEEVE PTO CL	1	
11a	D10042980	BUSH	1	
14a	D10043480	PIN PTO CL	1	
15	D10042700	BUSH	1	
16	D10042730	WASHER THRUST	1	
17	D90000180	CIRCLIP A15x0.90 SB	1	
18	D10043140	LINK ASSY PARKING BRK	1	
19	D93400060	CLEVIS 10x47.62 ADJUSTABLE	1	NI,
20	D10042770	HOSE OIL COOLER	1	

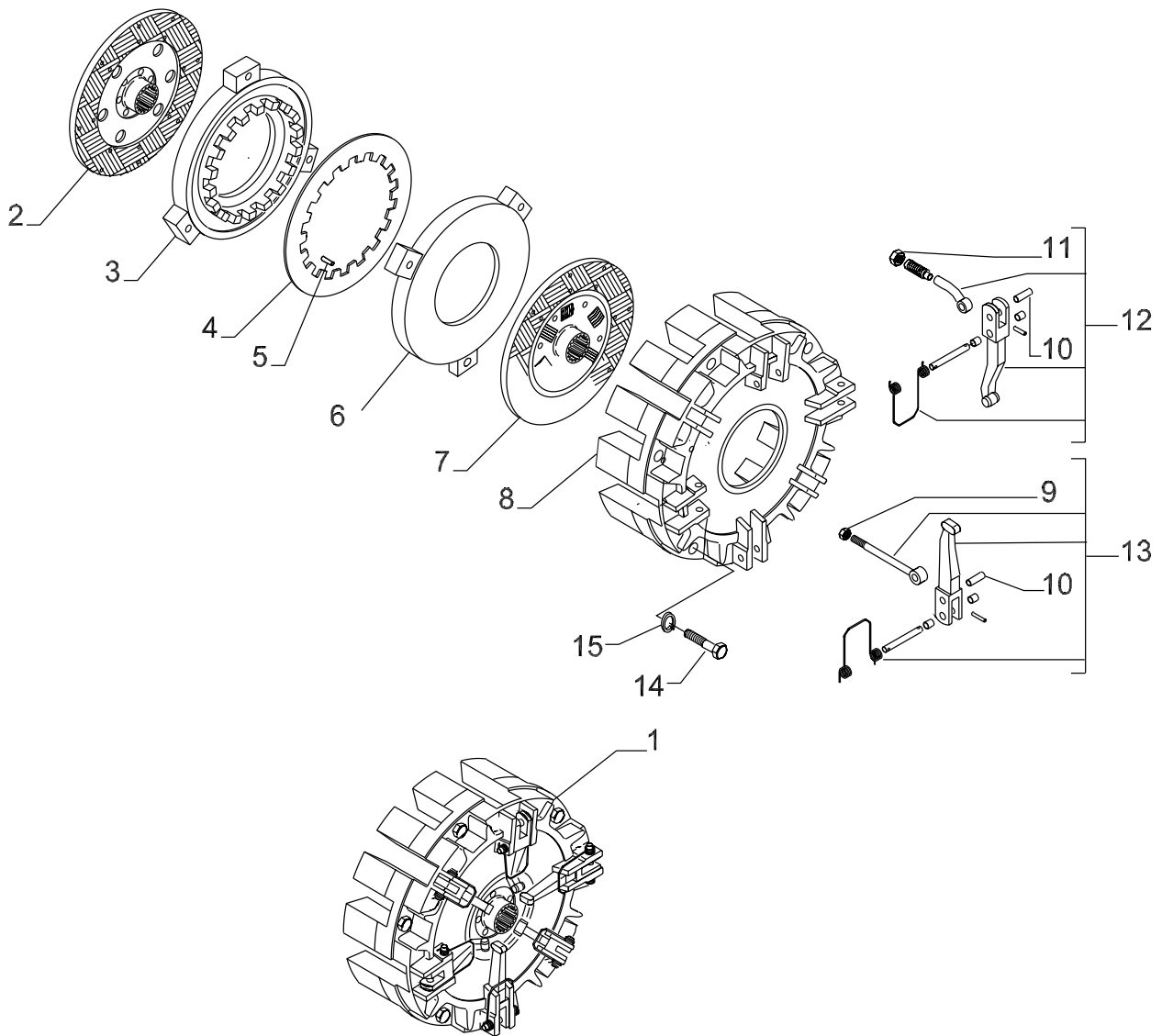

ITEM No.	PART NO.	DESCRIPTION	QTY	REMARKS
1	D10045800	CL ASSY DUAL	1	
2	D10017990	PLATE ASSY FRICTION DISC	1	
3	D10072580	PLATE	1	
4	D10072540	WASHER BELLEVILLE	1	
5	D10072550	PIN	3	
6	D10072590	PLATE	1	
7	D10103850	DISC CL MAIN DRIVE	1	
8	D10072600	HSG	1	
9	D10072610	NUT	3	
10	D10072570	PIN SPRING	6	
11	D10072560	NUT	3	
12	D10077150	KIT LEVER (CARRARO)	1	
13	D10077160	KIT LEVER (CARRARO)	1	
14	D81500670	BOLT M10x1.50x60-6G HEX HEAD	6	
15	D86500090	WASHER M10 SPRING LOCK	6	
16	D10045790	FLY WHL ASSY	1	
17	D10010460	BRG CL PILOT	1	
18	D10046150	RETAINER FLYWHL MNTG BOLT	3	
19	D81000990	BOLT 1/2"-20x1.375"	6	

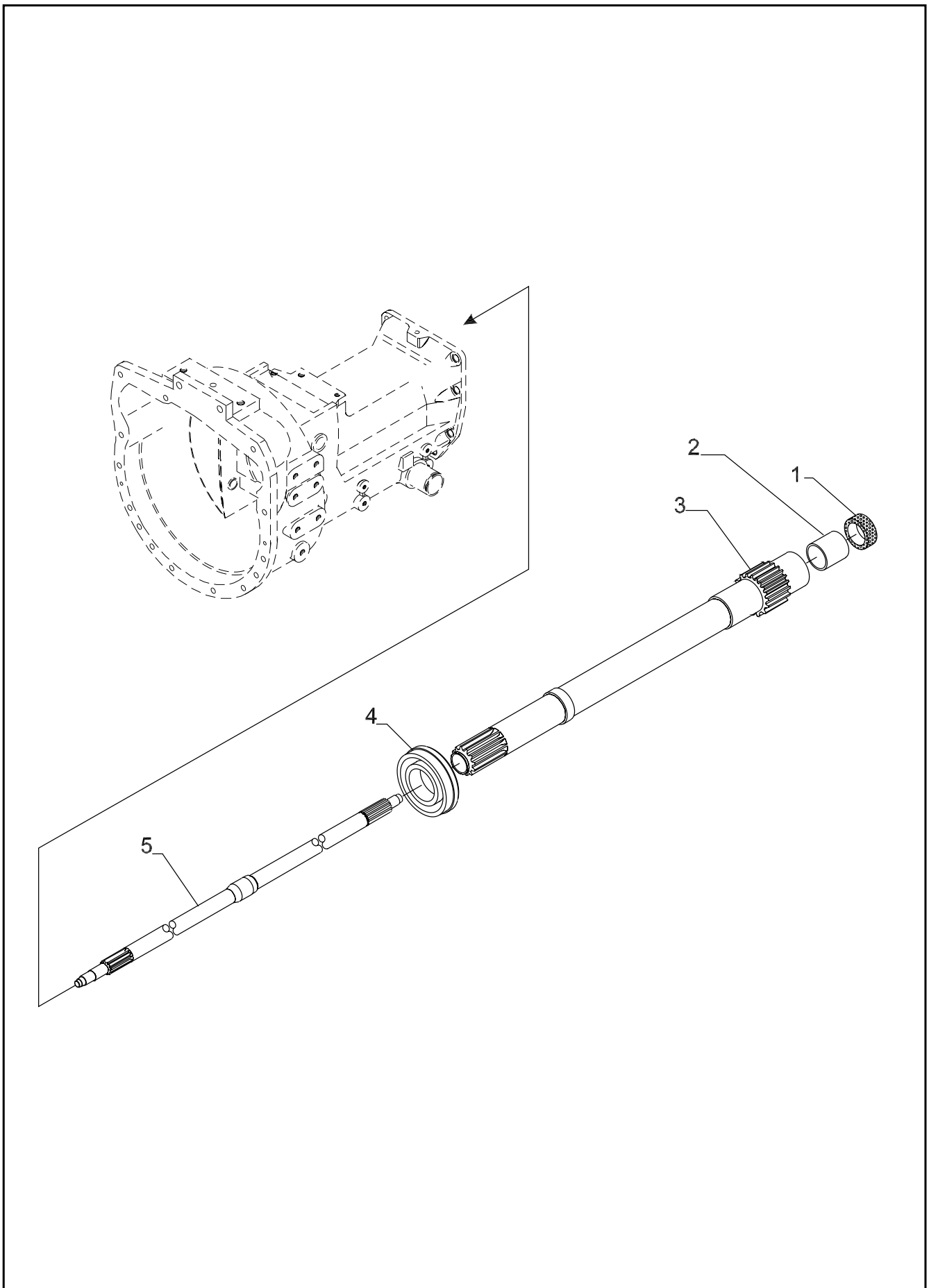

ITEM No.	PART NO.	DESCRIPTION	QTY	REMARKS
1	D10062520	SEAL OIL	1	
2	D10062540	BUSH	1	
3	D10103860	SHAFT	1	
4	D10061140	BRG 6308 2RS1(SKF)	1	
5	D10103870	SHAFT	1	

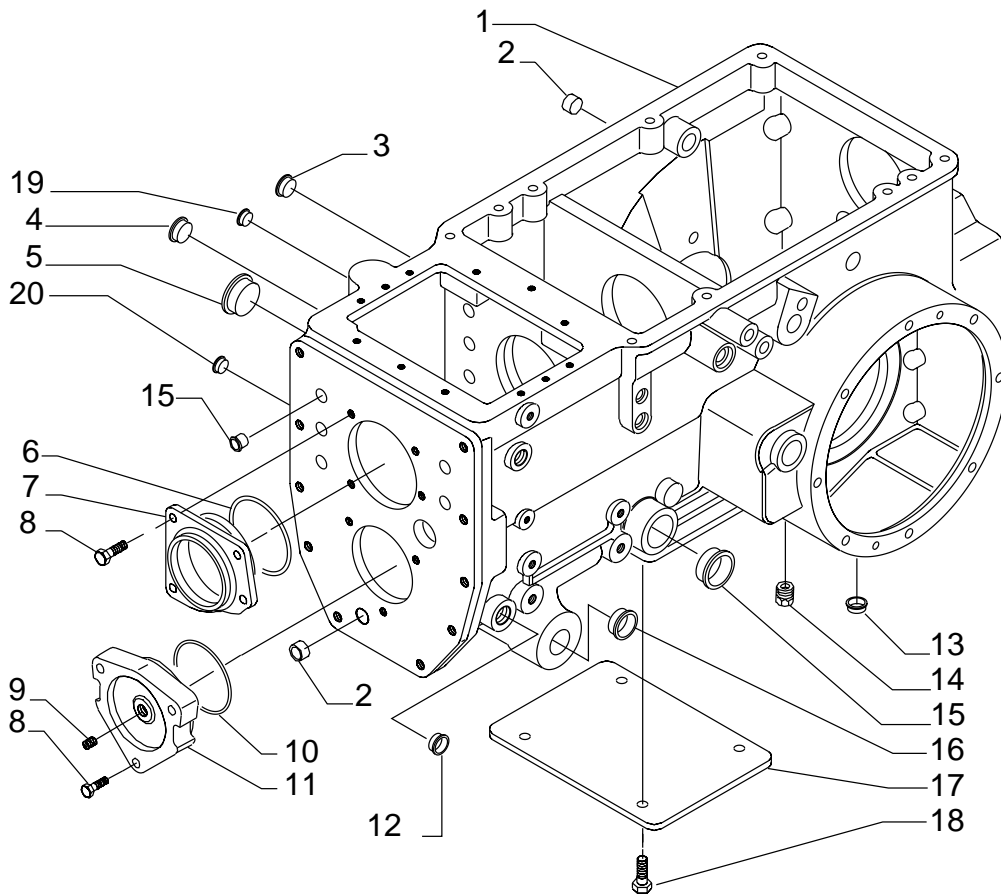

ITEM No.	PART NO.	DESCRIPTION	QTY	REMARKS
1	D10062560	HSG TRANSMISSION	1	
2	D10062570	PLUG D2035	2	
3	D10062590	PLUG D155	3	
4	D10062600	PLUG D205	1	
5	D10062610	PLUG D39	1	
6	D10062620	SEAL O RING	1	
7	D10062630	CVR	1	
8	D81501040	BOLT M8x1.25x25-9.8 HEX HEAD	7	
9	D10062660	PLUG	1	
10	D10062670	ORING	1	
11	D10062690	CVR	1	
12	D10062710	PLUG	1	
13	D10062720	PLUG D145	12	
14	D10084970	PLUG M24X1.5	1	NI,
15	D10062610	PLUG D39	1	
16	D10062760	PLUG D26	4	
17	D10062770	CVR	1	
18	D81500840	BOLT M12x35 HEX HEAD	4	
19	D10062780	PLUG D7	3	
20	D10062790	PLUG D11	10	

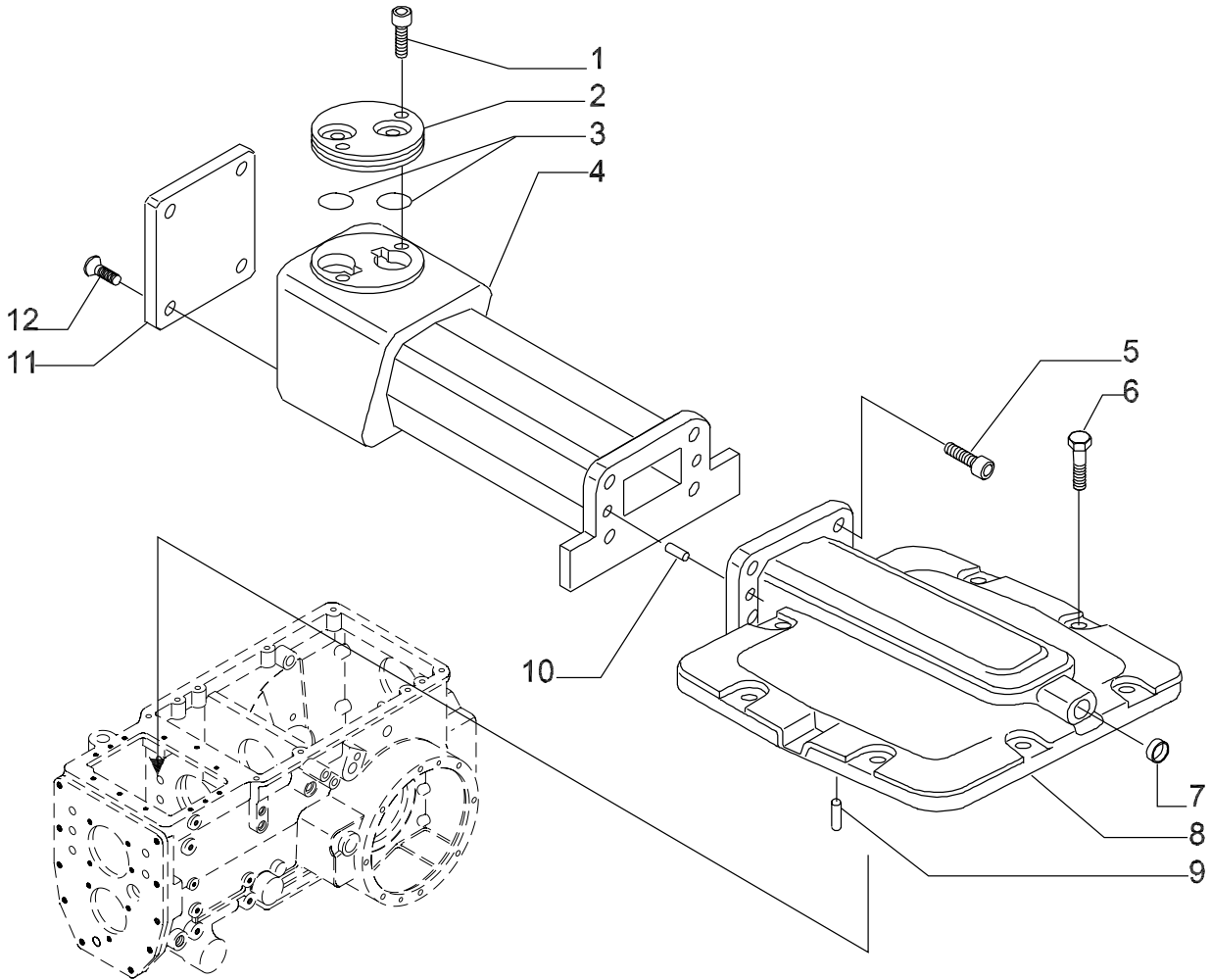

ITEM No.	PART NO.	DESCRIPTION	QTY	REMARKS
1	D82500420	SCREW M8X16	2	
2	D10062820	CVR	1	
3	D10062860	SEAL O RING	2	
4	D10062870	LEVER SUPPORT	1	
5	D82500440	SCREW M8X25	4	
6	D81500280	BOLT M10x1.50x25-6G HEX HEAD	8	
7	D10062880	PLUG	1	
8	D10062890	CVR	1	
9	D10062900	PIN	2	
10	D10062910	PIN	2	
11	D10062920	CVR	1	
12	D81500980	BOLT M6X12	4	

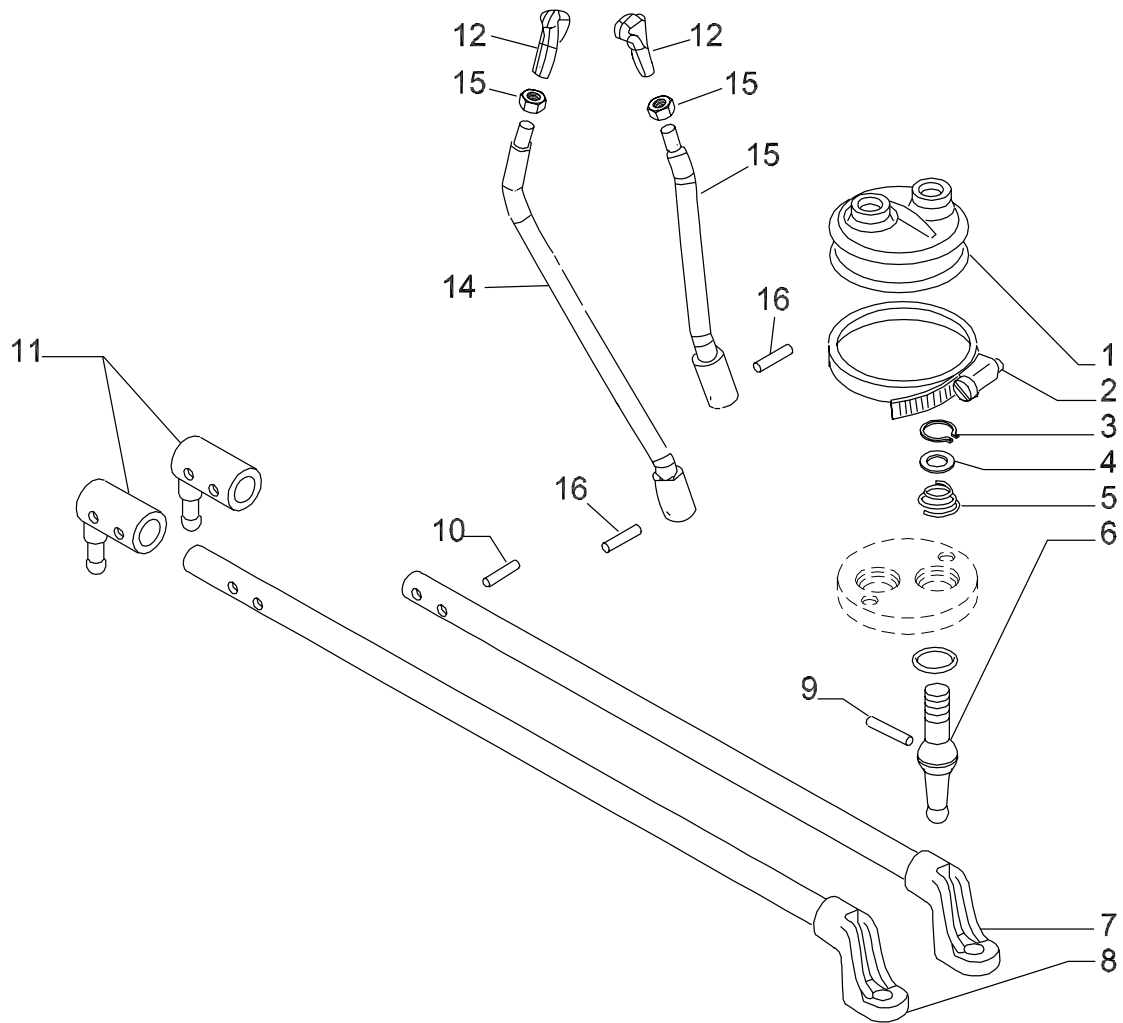

ITEM No.	PART NO.	DESCRIPTION	QTY	REMARKS
1	D10062940	BOOTH	1	
2	D10062960	CLAMP HOSE	1	
3	D90000340	RING SNAP D16	1	
4	D10063030	SHIM 26x165x1	5	
5	D10063040	SPRING	1	
6	D10063050	LEVER	2	
7	D10063060	INNER ROD	4	
8	D10063070	ROD INNER	4	
9	D10062910	PIN	1	
10	D93400250	PIN 6X25 COTTER	2	
11	D10063120	LEVER INNER	2	
12	D10042300	KNOB GR SHIFT	1	
13	D10042100	NUT M10x1.00 HEX	1	
14	D10043030	LEVER AND HUB ASSY TRANSMISSION	1	
15	D10043060	LEVER AND HUB ASSY GR SHIFT	1	
16	D87000110	PIN 6x25 SPRING	1	
17	D10042400	BOOT TRANSMISSION LEVER	1	

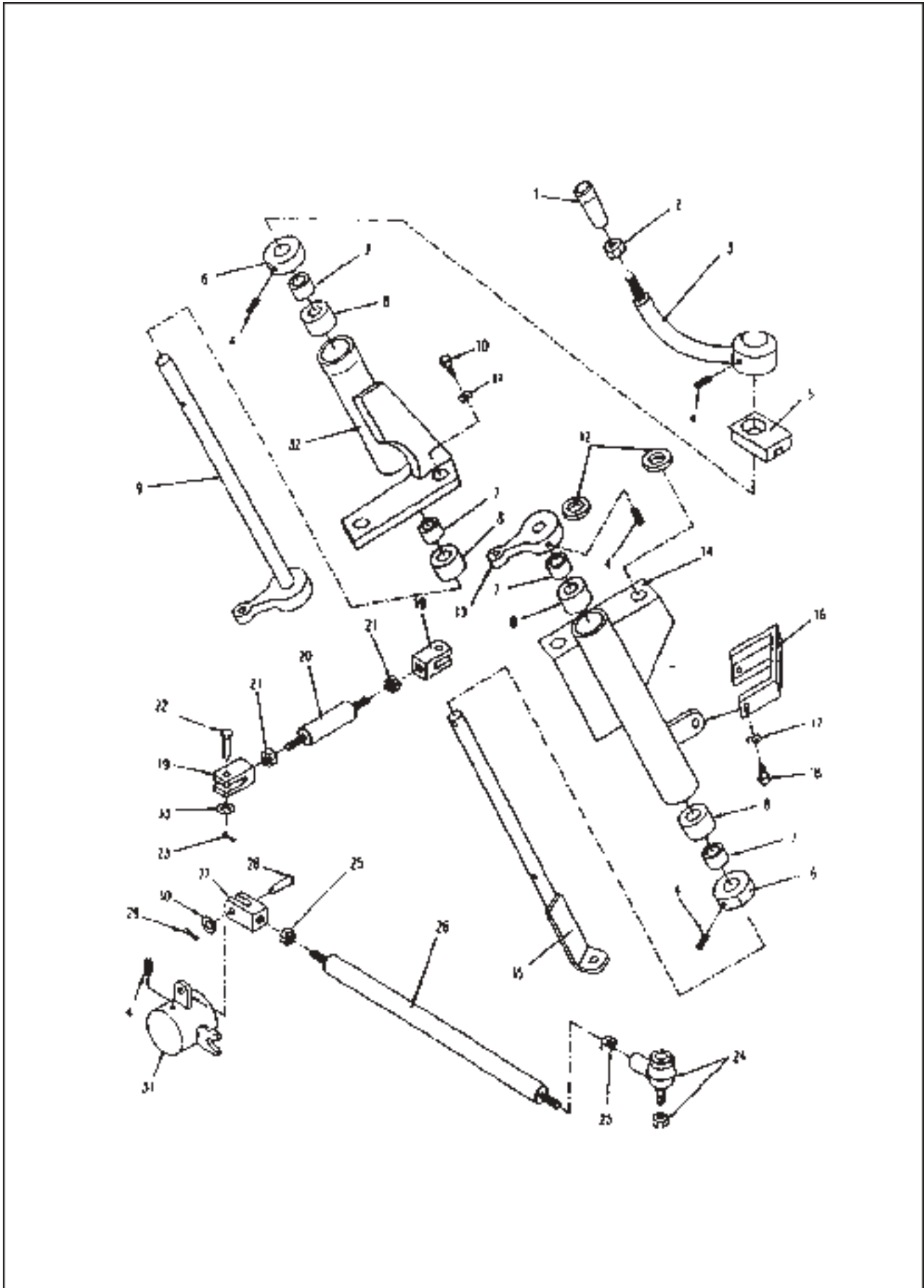

ITEM No.	PART NO.	DESCRIPTION	QTY	REMARKS
1	D10042300	KNOB GR SHIFT	1	
2	D10042100	NUT M10x1.00 HEX	1	
3	D10042090	HANDLE FORWARD REVERSE GR SHIFTER	1	
4	D87000120	PIN 6x30 SPRING	5	
5	D10042220	GROMMET SHAFT FORWARD REVERSE CABLE	1	
6	D10042080	RETAINER SHAFT GR SHIFT	2	
7	D10042980	BUSH	4	
8	D10043270	ADAPTER TUBE FORWARD REVERSE	4	
9	D10043330	SHAFT FORWARD REVERSE LH	1	
10	D81500610	BOLT M10x1.50x40-6G HEX HEAD	2	
11	D86500090	WASHER M10 SPRING LOCK	2	
12	D10042070	SPACER	1	
13	D10043350	LEVER FORWARD REVERSE SHAFT RH	1	
14	D10043340	BRACKET AND TUBE ASSY FORWARD REVERSE RH	1	
15	D10046490	SHAFT FORWARD REVERSE RH FT80	1	
16	D10043290	SUPPORT BRACKET AND TUBE ASSY RH	1	
17	D86500090	WASHER M10 SPRING LOCK	1	
18	D81500370	BOLT M10x1.50x30-6G HEX HEAD	1	
19	D10102360	CLEVIS 3/8"	2	NSS-34
20	D10103880	ROD ASSY BRK CONTROL	1	NSS-34
21	D83000010	NUT 3/8-24 HEX	1	
22	D93400030	PIN 3/8"x1.14" CLEVIS	2	
23	D10013460	PIN 1/8"x0.75" COTTER	2	
24	D10042110	BALL JOINT	1	
25	D83000010	NUT 3/8-24 HEX	2	
26	D10046470	ROD FORWARD REVERSE GR SHIFTER RH	1	
27	D10043280	CLEVIS FORWARD REVERSE GR	1	
28	D10042120	PIN FRONT LEVER	1	
29	D10013470	PIN 1/8"x1.00" COTTER	1	
30	D85500140	WASHER M10 FLAT	1	
31	D10043370	HUB AND LEVER ASSY FORWARD REVERSE	1	
32	D10039770	BRACKET AND TUBE ASSY	1	
33	D85000050	WASHER 3/8" FLAT	2	
34	D10017720	ROD AND CLEVIS ASSY BRK CONTROL	1	

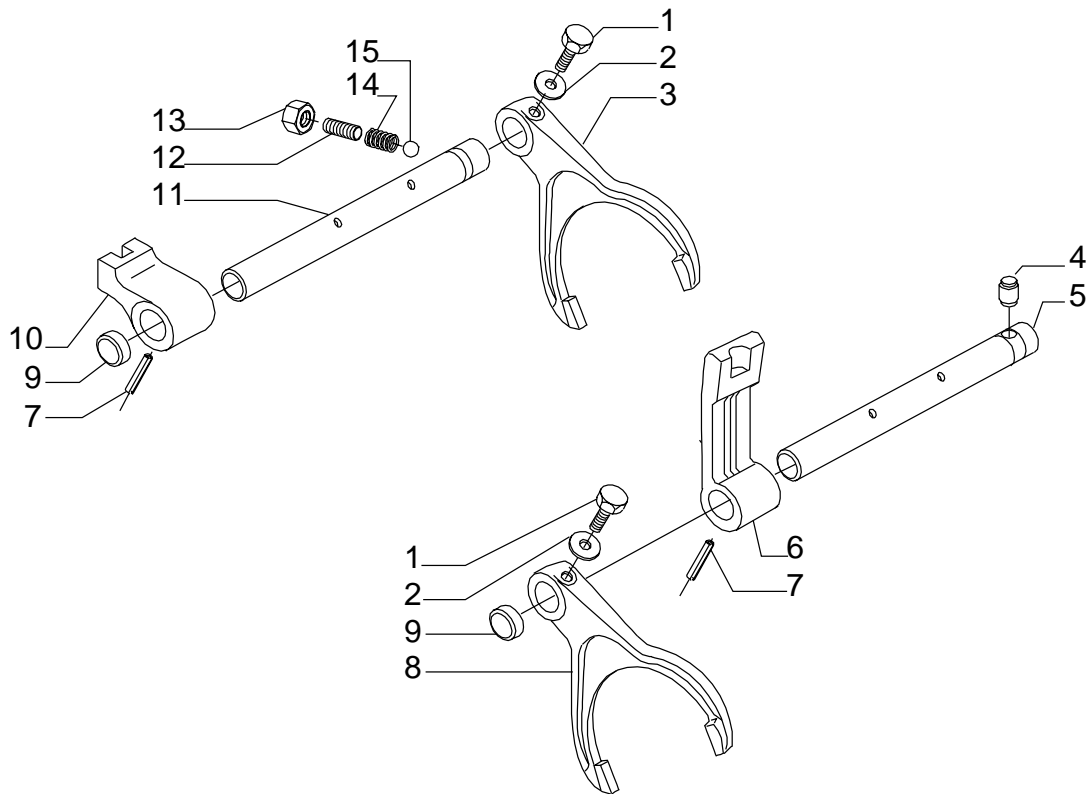

ITEM No.	PART NO.	DESCRIPTION	QTY	REMARKS
1	D81500850	BOLT	2	
2	D10063140	WASHER	2	
3	D10063250	FORK 1-2	1	
4	D10063260	PIN LOCK	1	
5	D10063280	ROD	1	
6	D10063290	BLOCK	1	
7	D10063300	PIN	2	
8	D10063320	FORK 3-4	1	
9	D10062570	PLUG D2035	2	
10	D10063330	BLOCK	1	
11	D10063340	ROD	1	
12	D10086240	GRUB SVREW M12X25	2	
13	D10086250	NUT M.12	2	
14	D10086230	SPRING	2	
15	D10063380	BALL	2	

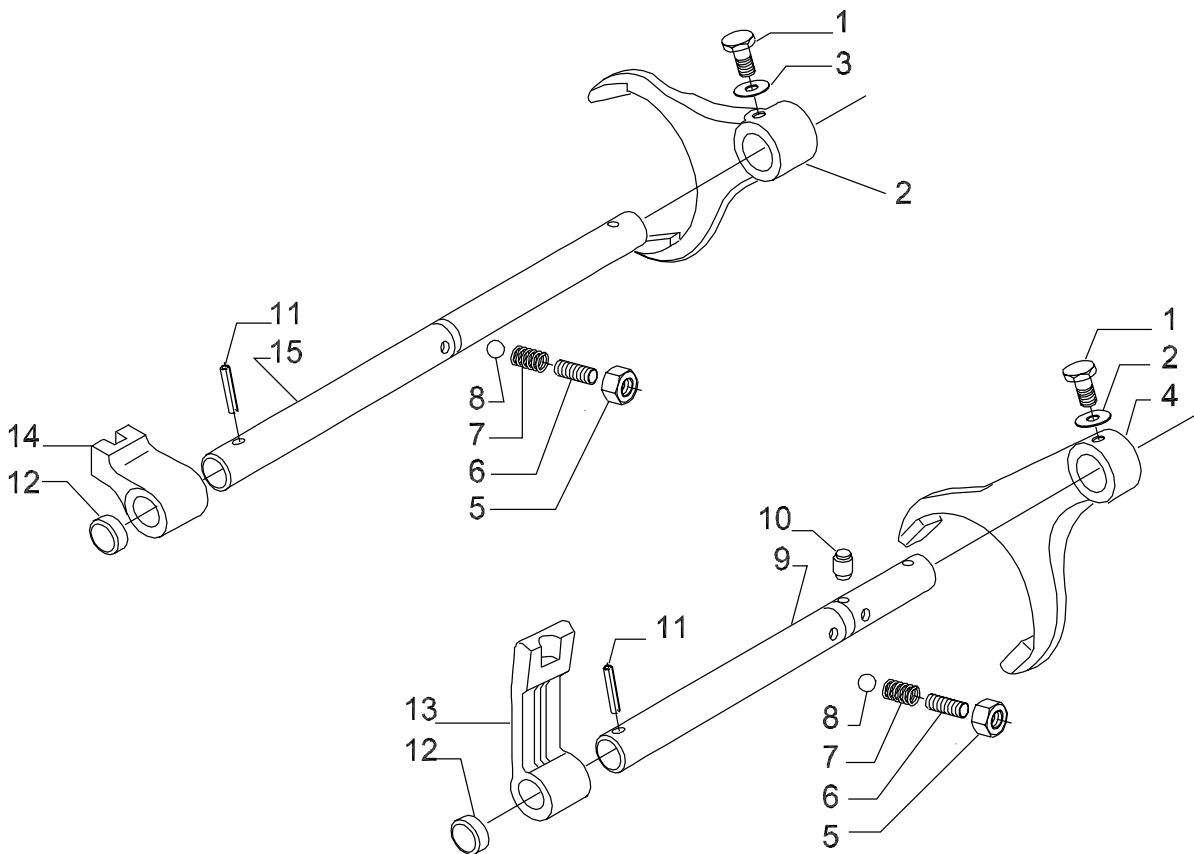

ITEM No.	PART NO.	DESCRIPTION	QTY	REMARKS
1	D81500850	BOLT	2	
2	D10063140	WASHER	2	
3	D10063390	FORK	1	
4	D10063450	FORK	1	
5	D10086250	NUT M.12	2	
6	D10086240	GRUB SVREW M12X25	2	
7	D10086230	SPRING	2	
8	D10063380	BALL	2	
9	D10063440	ROD	1	
10	D10063260	PIN LOCK	1	
11	D10063300	PIN	2	
12	D10062570	PLUG D2035	2	
13	D10063290	BLOCK	1	
14	D10063330	BLOCK	1	
15	D10063430	ROD	1	

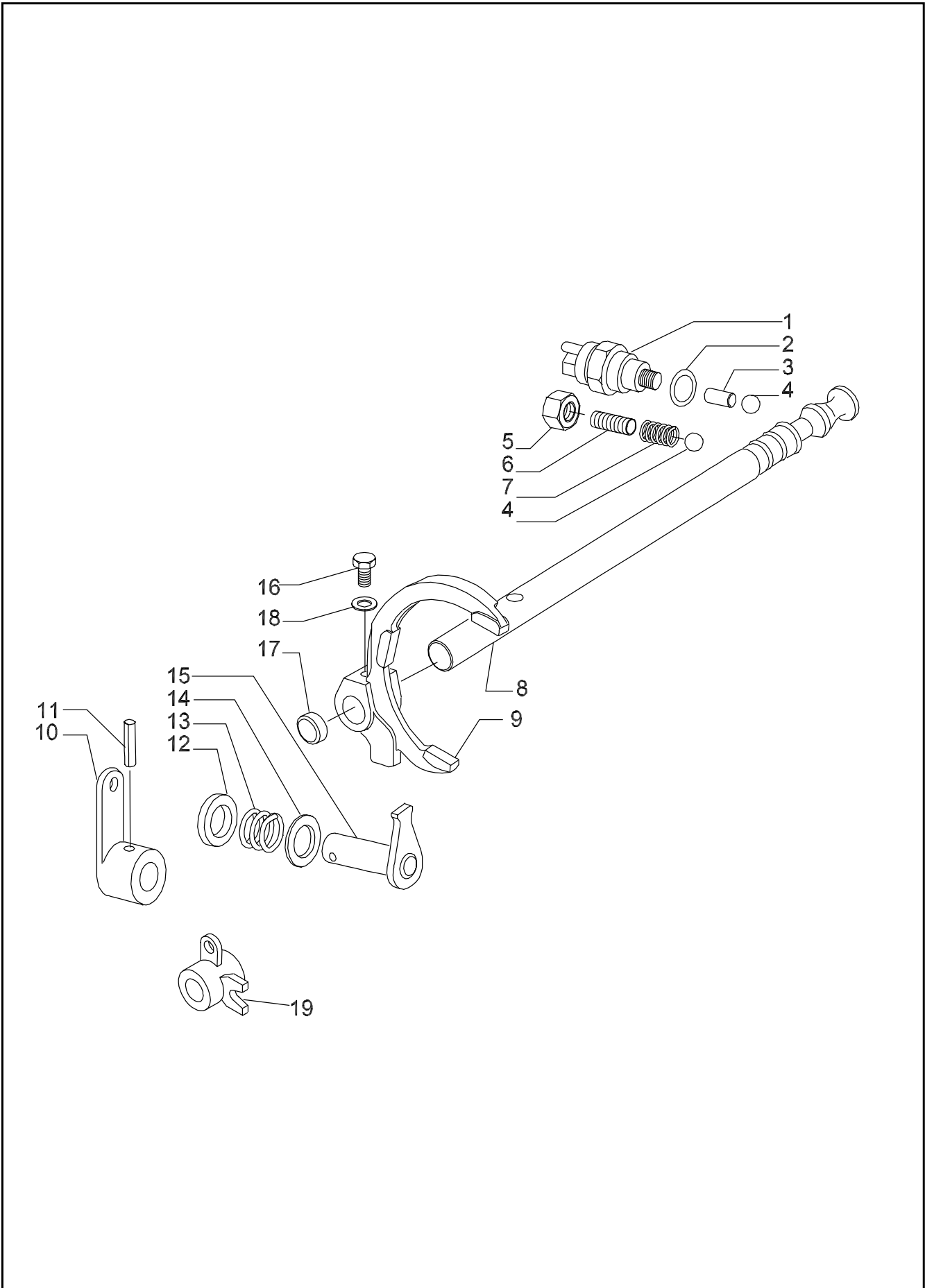

ITEM No.	PART NO.	DESCRIPTION	QTY	REMARKS
1	D10063460	SENSOR	1	
2	D10063470	WASHER	1	
3	D10063480	PIN D9X17	1	
4	D10063280	ROD	2	
5	D10086250	NUT M.12	1	
6	D10086240	GRUB SVREW M12X25	1	
7	D10086230	SPRING	1	
8	D10072640	ROD	1	
9	D10072630	FORK	1	
10	D10043310	LEVER AND HUB ASSY FORWARD REVERSE RH	1	
11	D93400200	SPLIT PIN	1	
12	D10063500	SEAL OIL	1	
13	D10063510	SPRING	1	
14	D10063520	WASHER	1	
15	D10063540	LEVER	1	
16	D81500850	BOLT	1	
17	D10062570	PLUG D2035	1	
18	D10063140	WASHER	1	
19	D10043310	LEVER AND HUB ASSY FORWARD REVERSE RH	1	

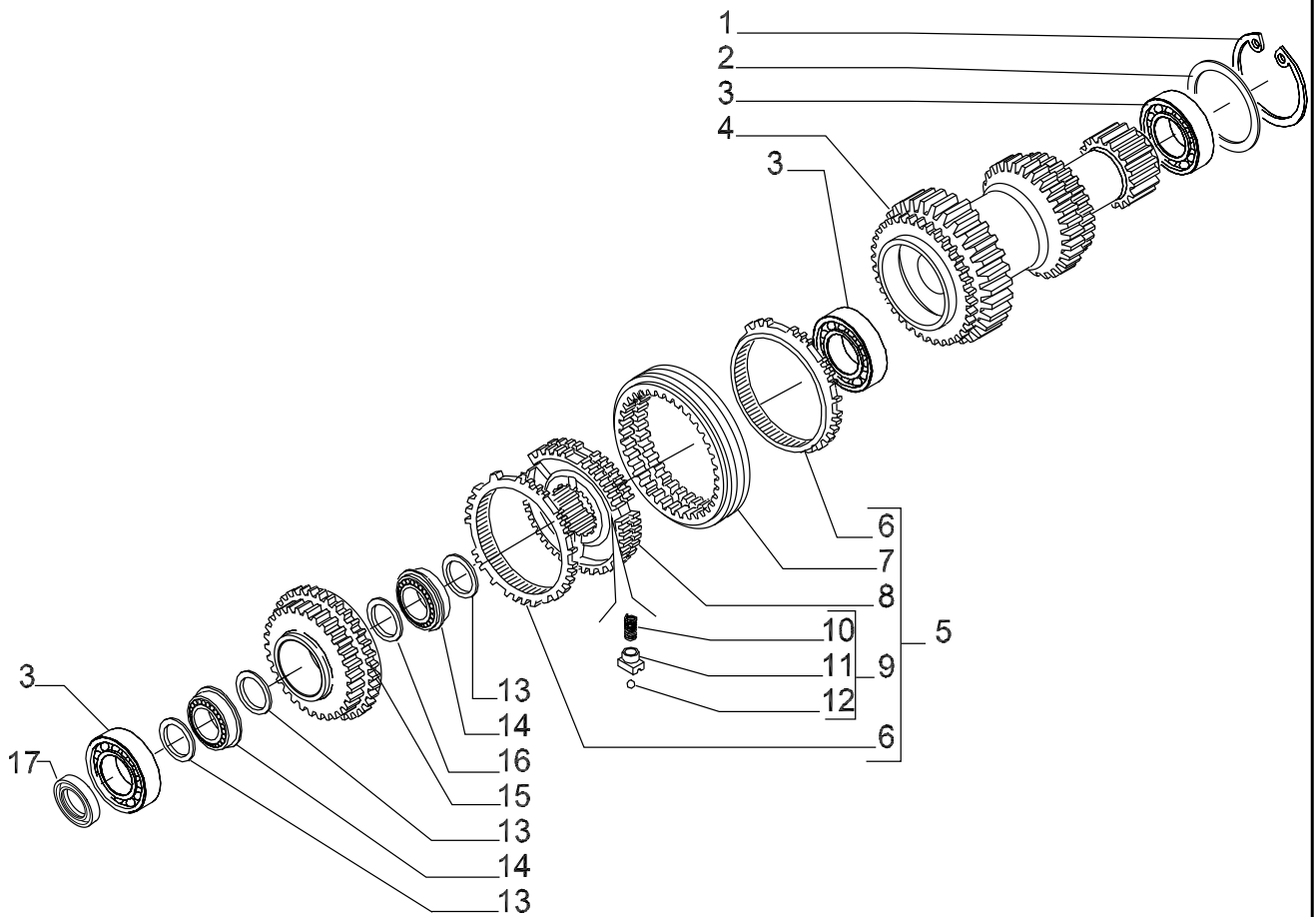

ITEM No.	PART NO.	DESCRIPTION	QTY	REMARKS
1	D90000280	RING SNAP	1	
2	D10065170	SHIM 005MM	AR	
2	D10063550	SHIM 1.0MM	AR	
2	D10063560	SHIM 3.0MM	AR	
3	D10063570	BRG	3	
4	D10063580	SHAFT PRIMARY	1	
5	D10076790	KIT SYNCHRONIZER	1	
6	D10103890	RING	2	NSS-5
7	D10103900	SLEEVE	1	NSS-5
8	2670184AA	HUB	1	
9	D10081580	KIT SPRING (CIL)	3	
10	D10103910	SPRING	3	NSS-9
11	D10103920	PAD	3	NSS-9
12	D10103930	BALL	3	NSS-9
13	D10063600	SHIM 5.0 MM	3	
14	D10063610	BRG	2	
15	D10063620	GR Z=26	1	
16	D10063600	SHIM 5.0 MM	AR	
16	D10063640	SHIM 3.0MM	AR	
16	D10063660	SHIM 1.0MM	AR	
17	D10063670	SEAL OIL	1	

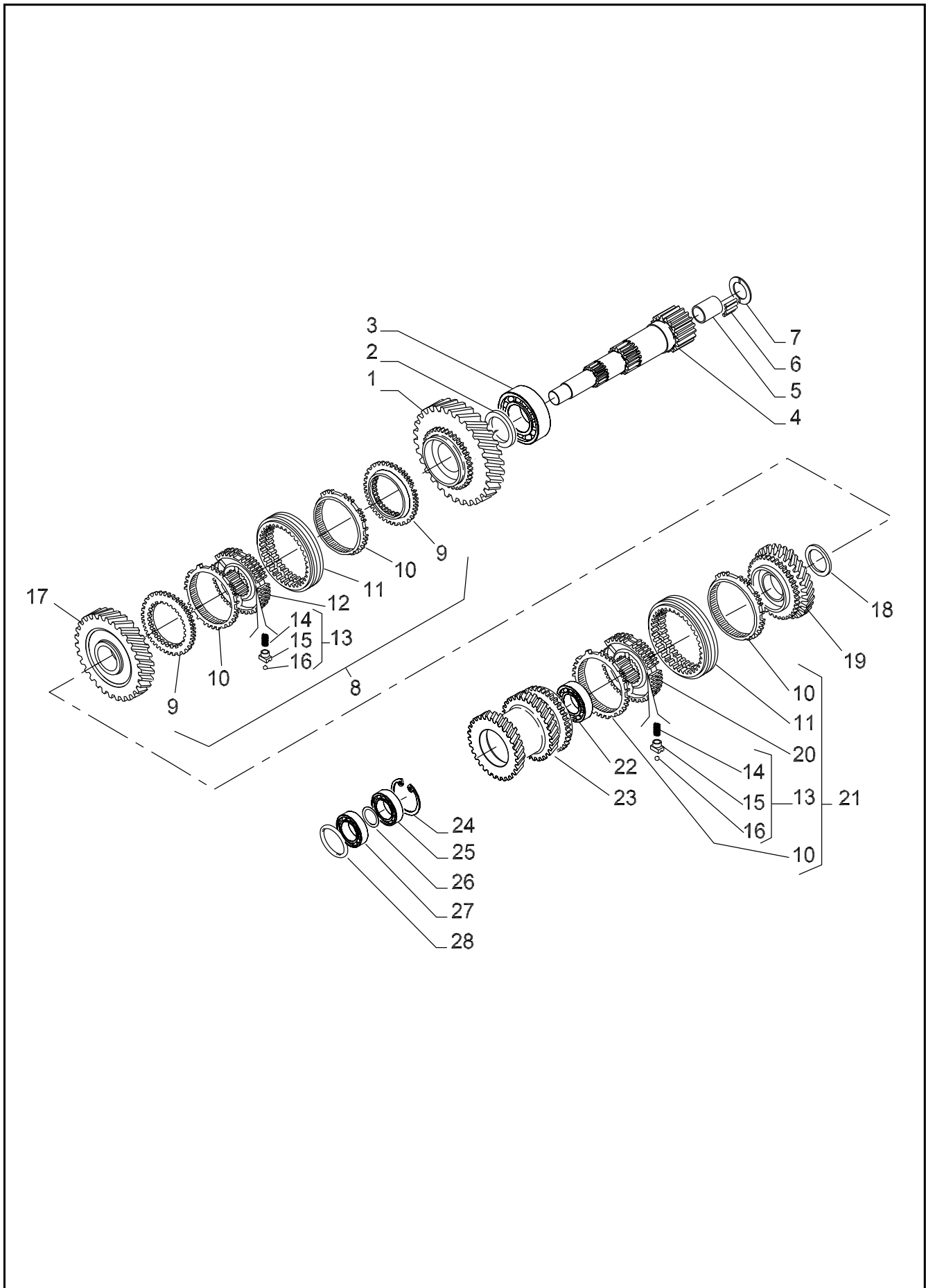

ITEM No.	PART NO.	DESCRIPTION	QTY	REMARKS
1	D10063680	GR Z=44	1	
2	D10063690	SPACER	1	
3	D10063700	BRG	1	
4	D10063710	SHAFT SECONDARY Z=20	1	
5	D10063720	BUSH	1	
6	D10063730	BRG NEEDLE ROLLER (BY TENS)	19	
7	D10063740	WASHER THRUST	1	
8	D10076800	KIT SYNCHRONIZER	1	
9	D10103940	RING	2	NSS-8
10	D10103950	RING	4	NSS-8
11	D10103900	SLEEVE	2	NSS-8
12	2670206AA	HUB	1	
13	D10081580	KIT SPRING (CIL)	6	
14	D10103910	SPRING	6	NSS-13
15	D10103920	PAD	6	NSS-13
16	D10103930	BALL	6	NSS-13
17	D10063750	GR Z=39	1	
18	D10063760	SPACER	1	
19	D10063770	GR Z=33	1	
20	2670214AA	HUB	1	
21	D10076810	KIT SYNCHRONIZER	1	
22	D10063780	BRG	1	
23	D10063790	GR Z=28/28	1	
24	D90000290	RING SNAP	1	
25	D10063800	BRG	1	
26	D10063810	SPACER	1	
27	D10063820	BRG	1	
28	D10063830	SHIM 01MM	AR	
28	D10063840	SHIM 03MM	AR	
28	D10063850	SHIM 05MM	AR	

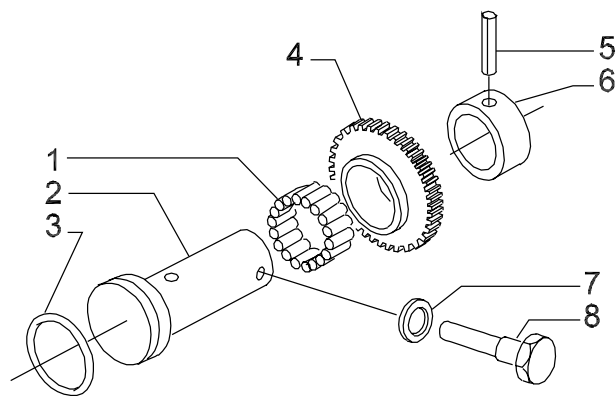

ITEM No.	PART NO.	DESCRIPTION	QTY	REMARKS
1	D10063860	BRG NEEDLES	1	
2	D10063870	SHAFT	1	
3	D10085560	O RING	1	
4	D10063890	GR Z=21	1	
5	D93400210	PIN COTTER	1	
6	D10063900	BUSH	1	
7	D10063900	BUSH	1	
8	D82500360	SCREW M12X47	1	

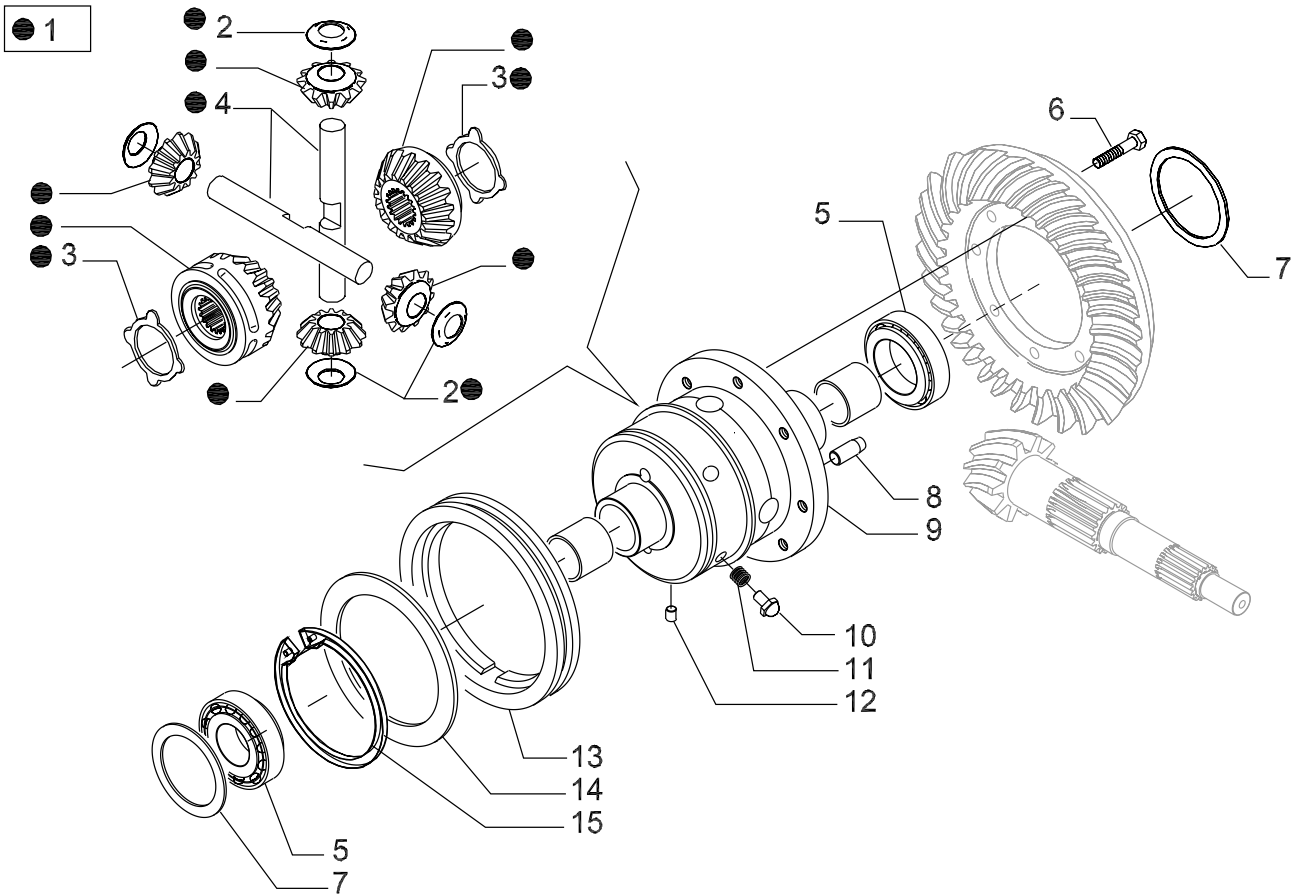

ITEM No.	PART NO.	DESCRIPTION	QTY	REMARKS
1	D10081590	KIT DIFFRENTIAL (CIL)	1	
2	D10064160	WASHER THRUST	4	
3	D10064170	WASHER THRUST	2	
4	D10064180	SHAFT	2	
5	D10064190	BRG	2	
6	D81500940	BOLT M12X80	8	
7	D10064200	SHIM 01MM	AR	
7	D10064210	SHIM 03MM	AR	
7	D10064220	SHIM 05MM	AR	
7	D10064230	SHIM 005MM	AR	
8	D10081640	PIN DOWEL	1	
9	D10064250	BOX DIFFERENTIAL	1	
10	D10064260	PIN	4	
11	D10064270	SPRING	4	
12	D10064280	PIN	1	
13	D10064290	SLEEVE	1	
14	D10064300	FLANGE	1	
15	D90000310	RING SNAP	1	

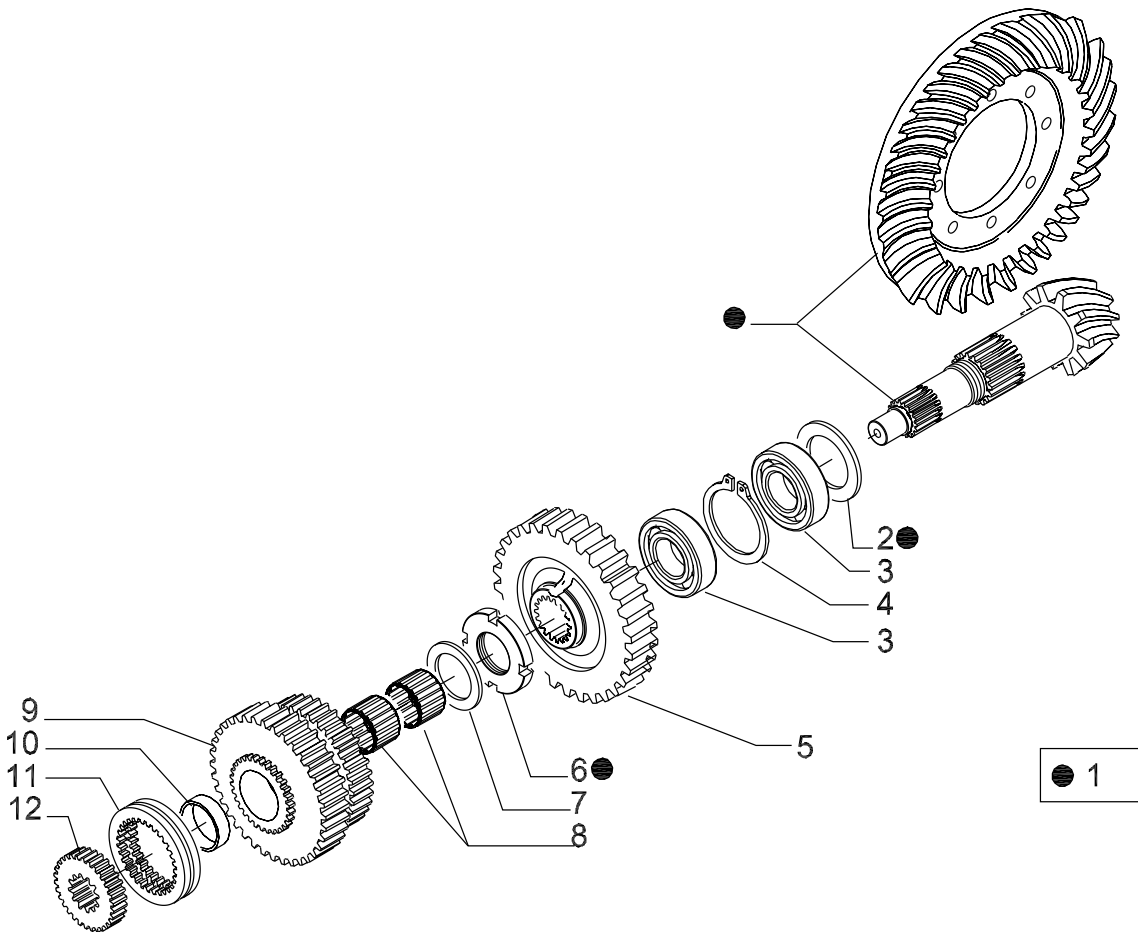

ITEM No.	PART NO.	DESCRIPTION	QTY	REMARKS
1	D10081610	SET FINAL DRIVE REDUCTION GRS (Z-12/38)	1	
2	D10063930	SHIM 250MM	4	
2	D10063940	SHIM 260MM	AR	
2	D10063950	SHIM 270MM	AR	
2	D10063960	SHIM 280MM	AR	
2	D10063970	SHIM 290MM	AR	
2	D10063990	SHIM 300MM	AR	
2	D10064000	SHIM 310MM	AR	
2	D10064010	SHIM 320MM	AR	
2	D10064020	SHIM 330MM	AR	
2	D10064030	SHIM 340MM	AR	
2	D10064040	SHIM 350MM	AR	
3	D10064060	BRG	2	
4	D90000300	RING SNAP	1	
5	D10064070	GR Z=40	1	
6	D10064080	RING NUT M45X15	1	
7	D10064090	WASHER THRUST	1	
8	D10064100	BRG NEEDLES	2	
9	D10064110	GR Z=34/26	1	
10	D10064120	SPACER	1	
11	D10064130	COLLAR	1	
12	D10064140	CL CENTRAL	1	

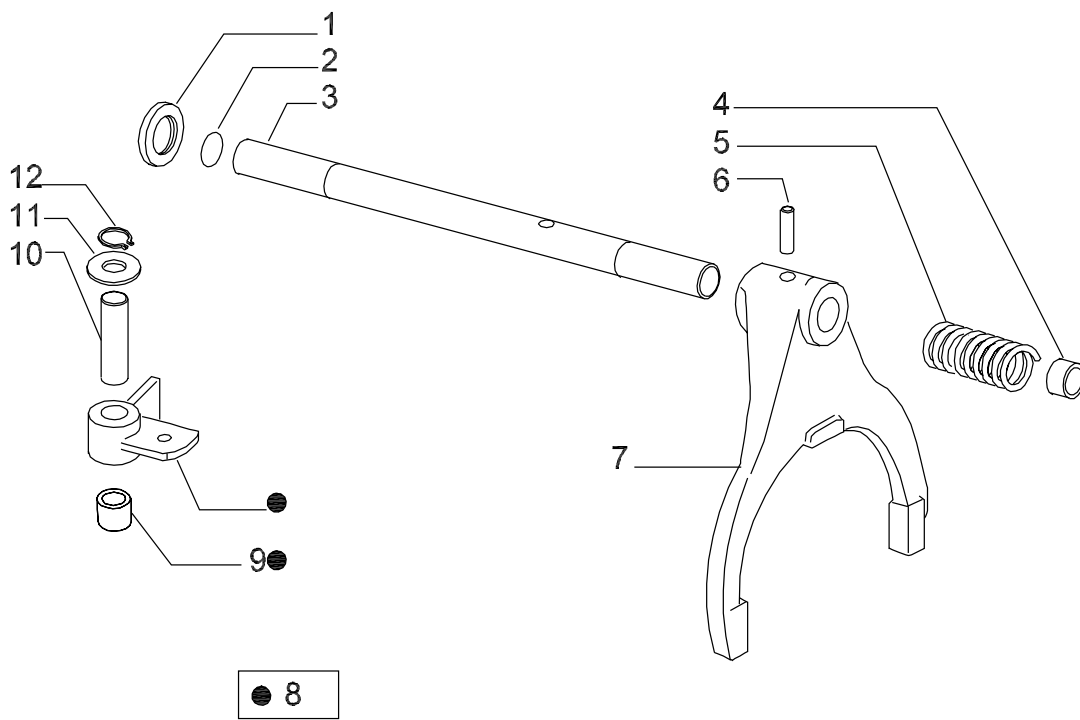

ITEM No.	PART NO.	DESCRIPTION	QTY	REMARKS
1	D10064310	RING SEAL	1	
2	D10064330	SEAL O RING	1	
3	D10064340	DIFFERENTIAL BLOCK DRIVE	1	
4	D10062570	PLUG D2035	1	
5	D10064350	SPRING	1	
6	D87000130	PIN 8x35 SPRING	1	
7	D10064370	DIFFERENTIAL BLOCK FORK	1	
8	D10081620	KIT LEVER (CIL - 066722)	1	
9	D10042700	BUSH	1	
10	D10064390	PIN 15X51	1	
11	D10042730	WASHER THRUST	1	
12	D90000180	CIRCLIP A15x0.90 SB	1	

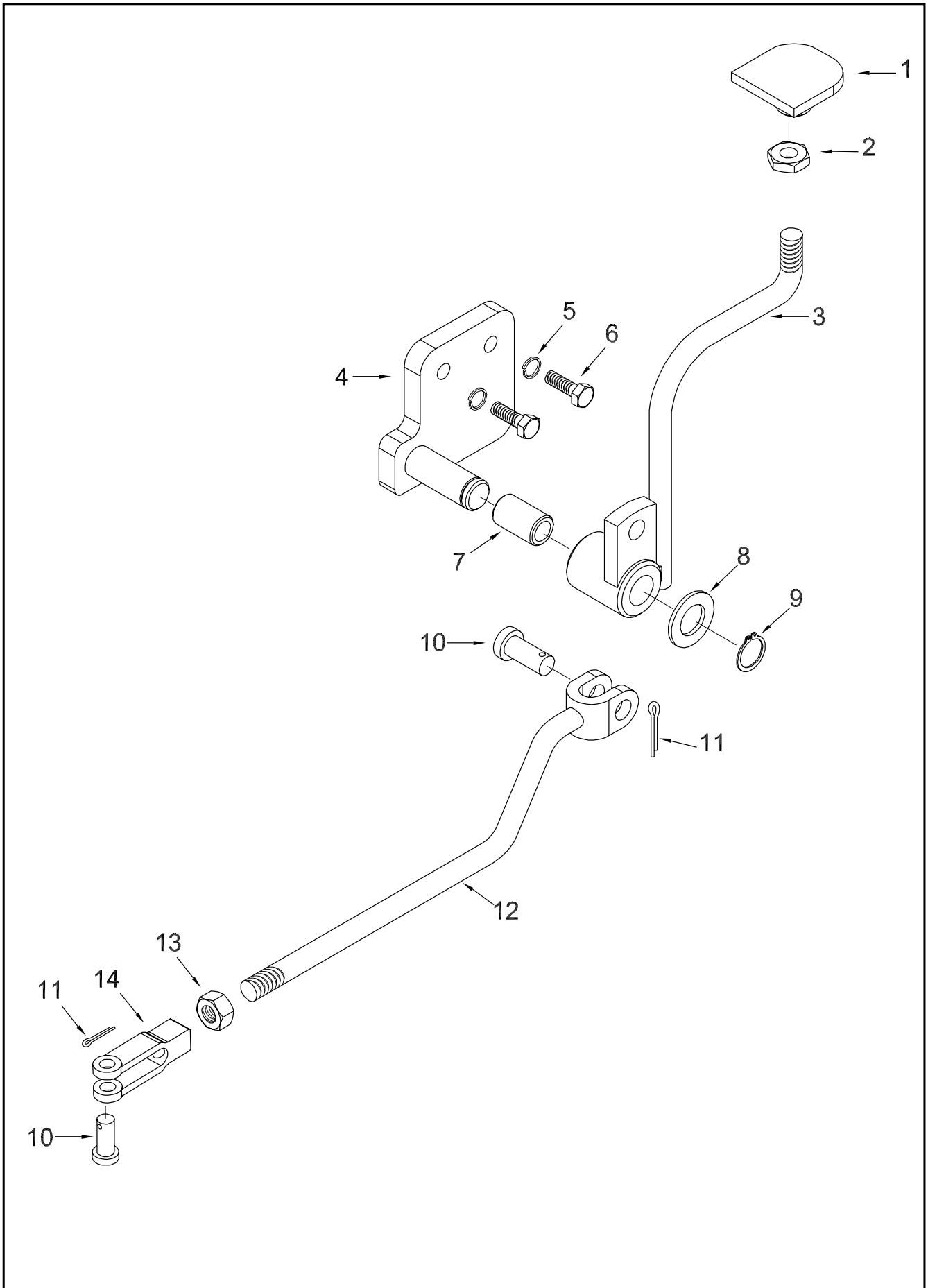

ITEM No.	PART NO.	DESCRIPTION	QTY	REMARKS
1	D10043430	PDL DIFFERENTIAL LOCK	1	NSS-3
2	D83500520	NUT M10x1.50-6 HEX HEAD THIN (CHROME PASSIVATED)	1	NSS-3
3	D10039750	PDL ASSY DIFFERENTIAL LOCK	1	
3a	D10105380	SPRING REAR AXLE DIFFERENTIAL LOCK	1	NI,
4	D10042480	BRACKET ASSY DIFFERENTIAL LOCK	1	
5	D86500150	WASHER M8 SPRING LOCK	2	
6	D81500590	BOLT M8x1.25x25-6.6 HEX HEAD	2	
7	D10042700	BUSH	1	
8	D10042730	WASHER THRUST	1	
9	D90000180	CIRCLIP A15x0.90 SB	1	
10	D93400030	PIN 3/8"x1.14" CLEVIS	2	
11	D10013460	PIN 1/8"x0.75" COTTER	2	
12	D10042720	ROD AND CLEVIS ASSY	1	
13	D83500450	NUT M10x1.50 HEX	1	
14	D93400060	CLEVIS 10x47.62 ADJUSTABLE	1	NSS-12

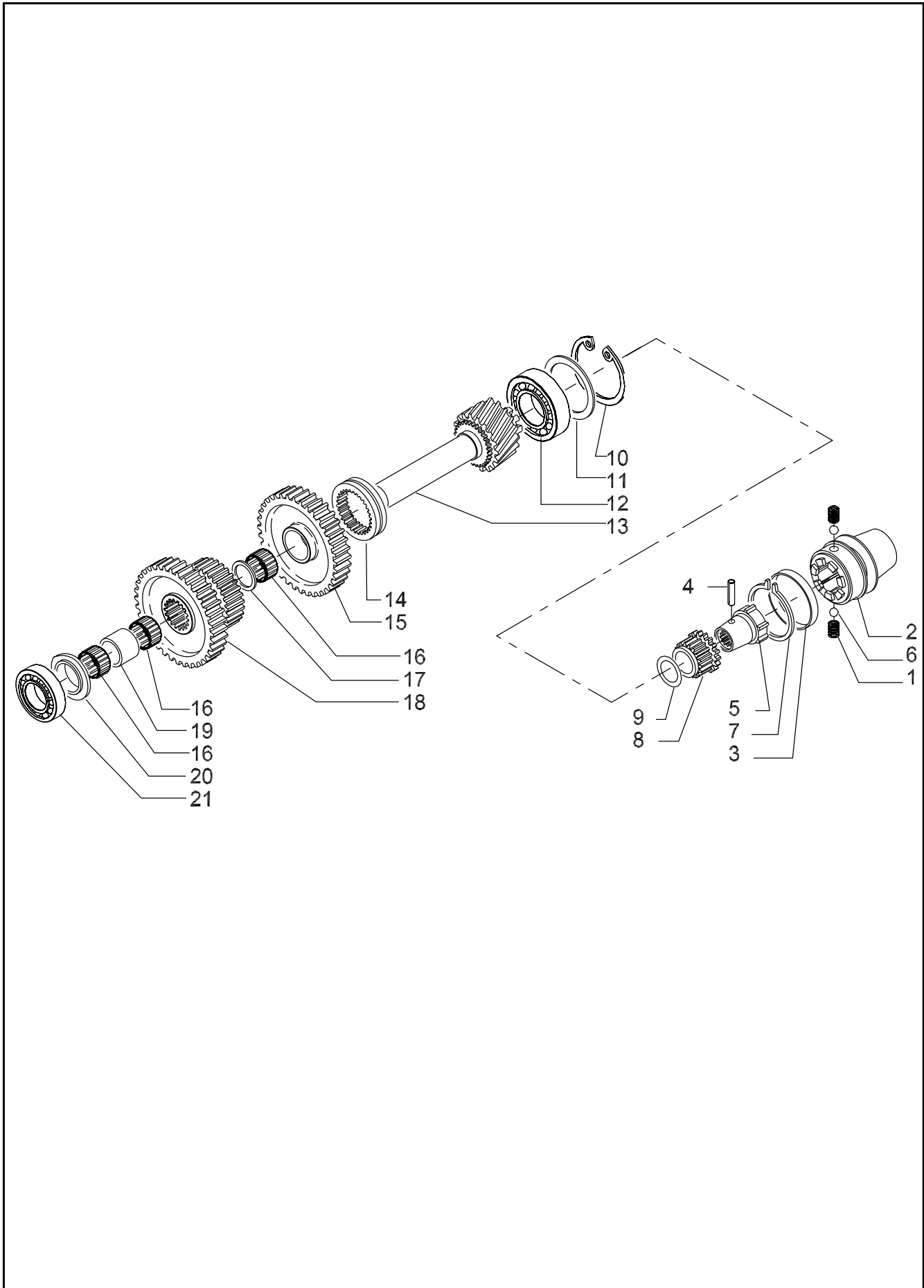

ITEM No.	PART NO.	DESCRIPTION	QTY	REMARKS
1	D10064400	SPRING	2	
2	D10064410	CL PTO SYNCHRONISING	1	
3	D10064420	RING LOCK	1	
4	D10064430	PIN D5X26	2	
5	D10064440	CL PTO	1	
6	D10064450	BALL D1/4"	2	
7	D90000320	RING SNAP	1	
8	D10064460	RING PTO LOCK	1	
9	D10064470	WASHER	1	
10	D90000360	RING SNAP D90	1	
11	D10064200	SHIM 01MM	AR	
11	D10064210	SHIM 03MM	AR	
11	D10064220	SHIM 05MM	AR	
12	D10064480	BRG	1	
13	D10064490	SHAFT GR Z-20	1	
14	D10064500	COLLAR	1	
15	D10064510	GR Z-33	1	
16	D10064520	BRG NEEDLES	3	
17	D10064530	SPACER	1	
18	D10064540	GR Z-25/39	1	
19	D10064550	SPACER	1	
20	D10064560	WASHER	1	
21	D10063570	BRG	1	

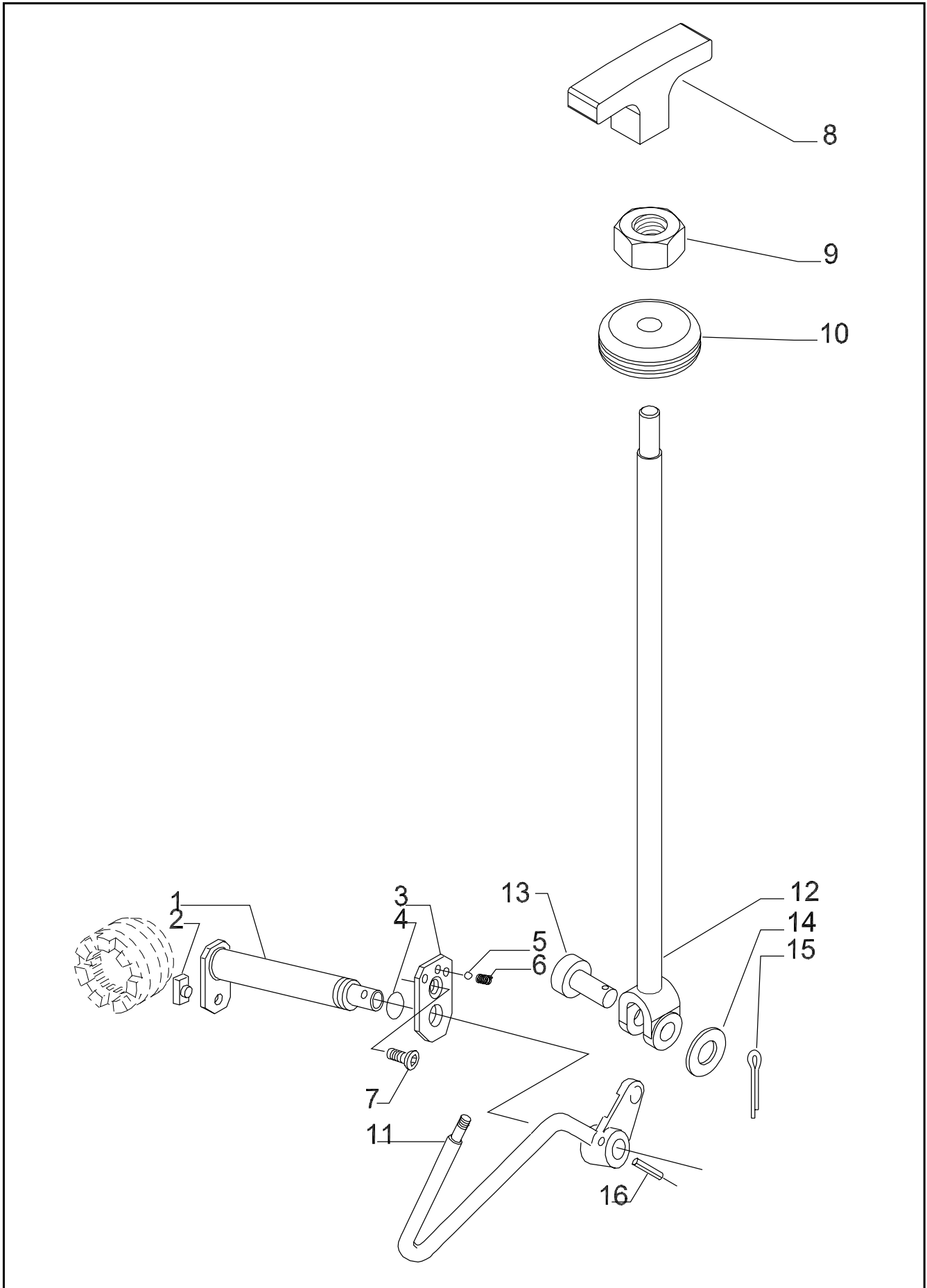

ITEM No.	PART NO.	DESCRIPTION	QTY	REMARKS
1	D10064570	SHAFT	1	
2	D10064580	PAD	1	
3	D10064590	PLATE	1	
4	D10064330	SEAL O RING	1	
5	D10064450	BALL D1/4"	1	
6	D10064400	SPRING	1	
7	D82500430	SCREW M8X16	1	
8	D10042460	KNOB PTO	1	
9	D83500450	NUT M10x1.50 HEX	1	
10	D10018640	GROMMET	1	
11	D10081630	LEVER FRONT PTO (CIL)	1	
12	D10042470	ROD ASSY PTO ENGAGE	1	
13	D10017560	PIN 3/8"x13/16" CLEVIS	1	
14	D85000010	WASHER 3/8" FLAT	1	
15	D10013450	PIN 3/32"x0.75" COTTER	1	
16	D10064610	PIN 6x28 COTTER	1	

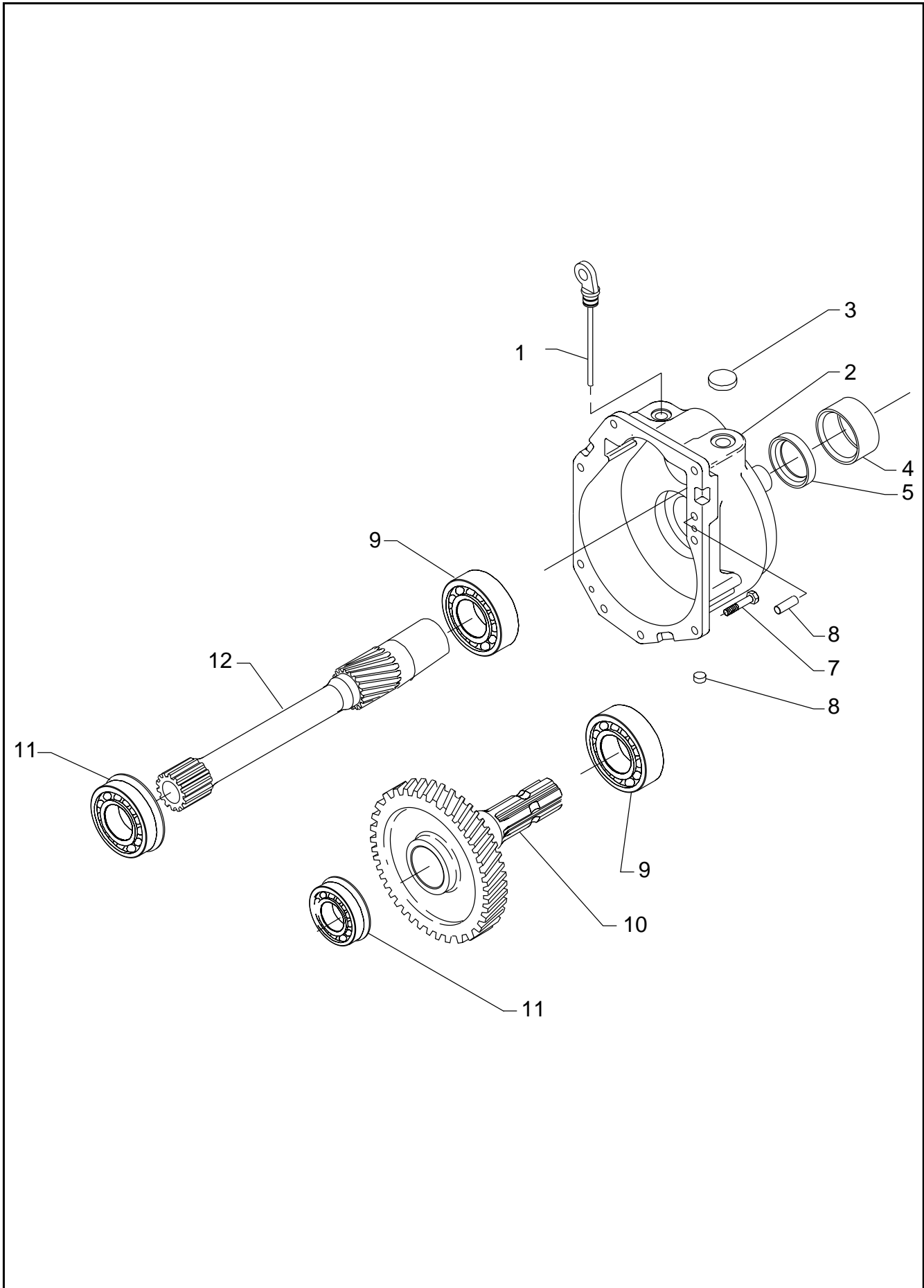

ITEM No.	PART NO.	DESCRIPTION	QTY	REMARKS
1	D10064680	STICK OIL DIP (CARRARO PART NO 133813)	1	
2	D10064690	CVR	1	
3	D10065160	PLUG	1	
4	D10061060	SEAL OIL (126403)	1	
5	D10061050	SEAL OIL (25150)	1	
6	D10081640	PIN DOWEL	2	
7	D81500280	BOLT M10x1.50x25-6G HEX HEAD	7	
8	D10064700	PLUG (CARRARO PART NO 114973)	1	
9	D10063570	BRG	2	
10	D10061070	SHAFT PTO (139674)	1	
11	D10064630	BRG	2	
12	D10099160	SHAFT PTO	1	

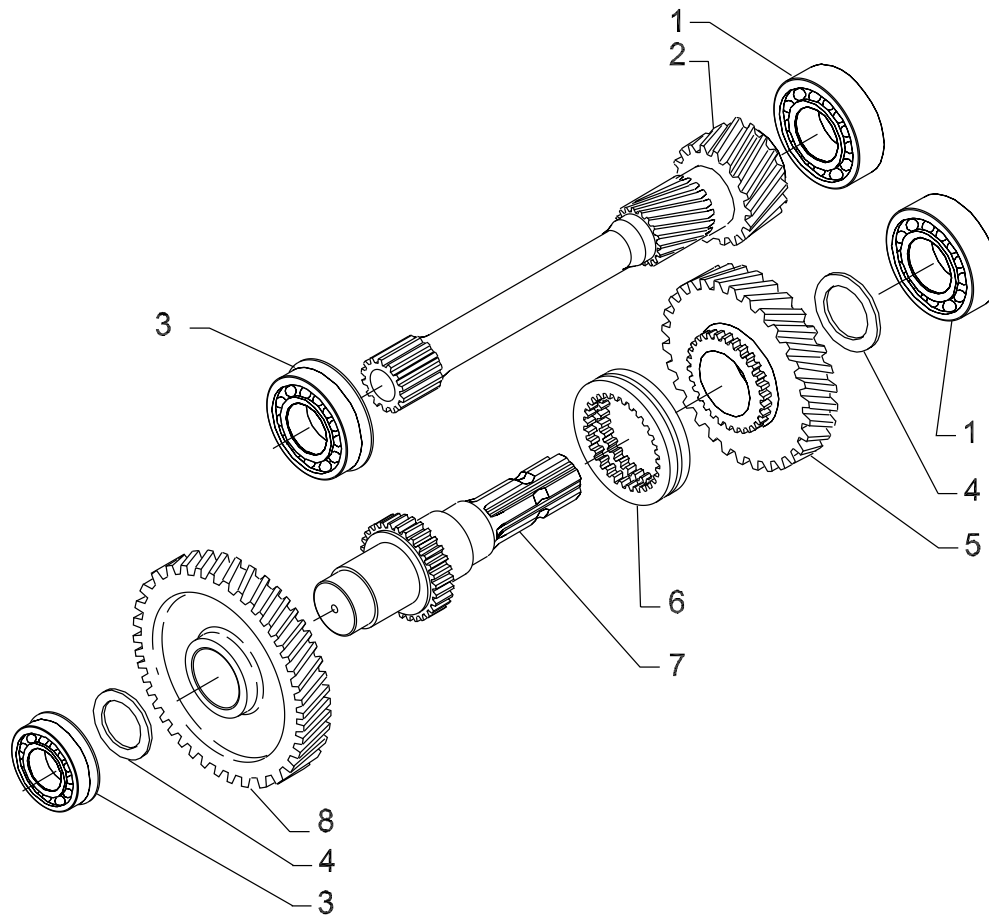

ITEM No.	PART NO.	DESCRIPTION	QTY	REMARKS
1	D10063570	BRG	2	
2	D10064620	SHAFT PTO Z-12/19	1	
3	D10064630	BRG	2	
4	D10064640	WASHER	2	
5	D10064650	GR Z-40	1	
6	D10064130	COLLAR	1	
7	D10064660	SHAFT PDF	1	
8	D10064670	GR Z-47	1	

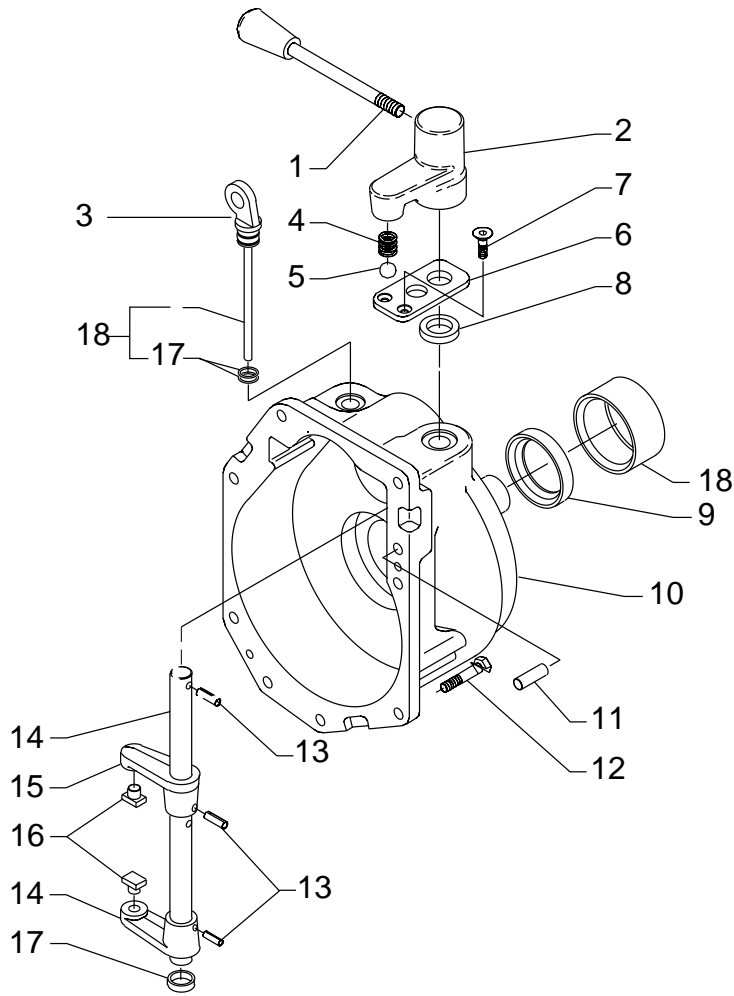

ITEM No.	PART NO.	DESCRIPTION	QTY	REMARKS
1	2670301AA	PTO LEVER	1	
2	2670302AA	PTO LEVER	1	
3	D10064680	STICK OIL DIP (CARRARO PART NO 133813)	1	
4	D10064400	SPRING	1	
5	D10064450	BALL D1/4"	1	
6	2670304AA	PLATE	1	
7	D82500430	SCREW M8X16	1	
8	D10105870	SEAL OIL DISTRIBUTOR	1	
9	D10061050	SEAL OIL (25150)	1	
10	D10064690	CVR	1	
11	D10081640	PIN DOWEL	2	
12	D81500280	BOLT M10x1.50x25-6G HEX HEAD	7	
13	D10064430	PIN D5X26	3	
14	2670310AA	DRIVE SHAFT	1	
15	2670311AA	LEVER	2	
16	2670312AA	PAD	2	
17	D10064700	PLUG (CARRARO PART NO 114973)	1	
18	D10061060	SEAL OIL (126403)	1	

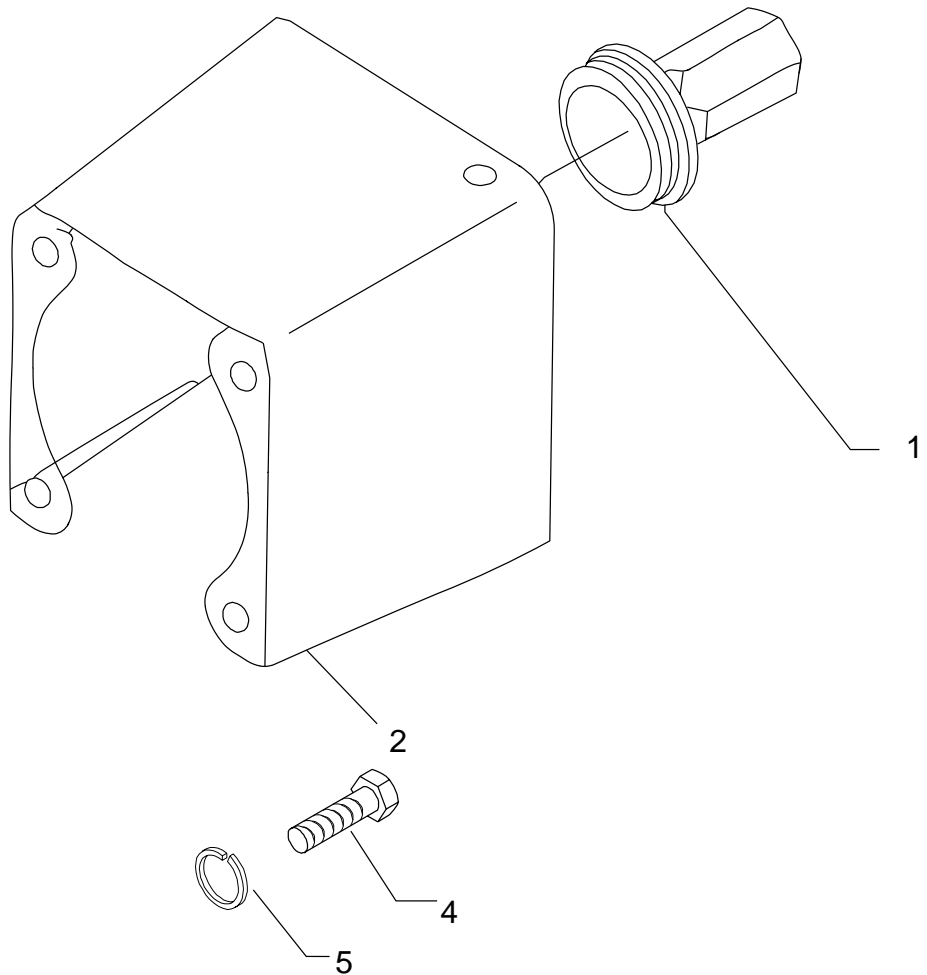

ITEM No.	PART NO.	DESCRIPTION	QTY	REMARKS
1	D10042010	CAP PTO	1	
2	D10039730	GUARD PTO	1	
4	D82500090	SCREW M12x1.75x25-6.6 HEX HEAD	4	
5	D86000060	WASHER 1/2" SPRING LOCK	2	

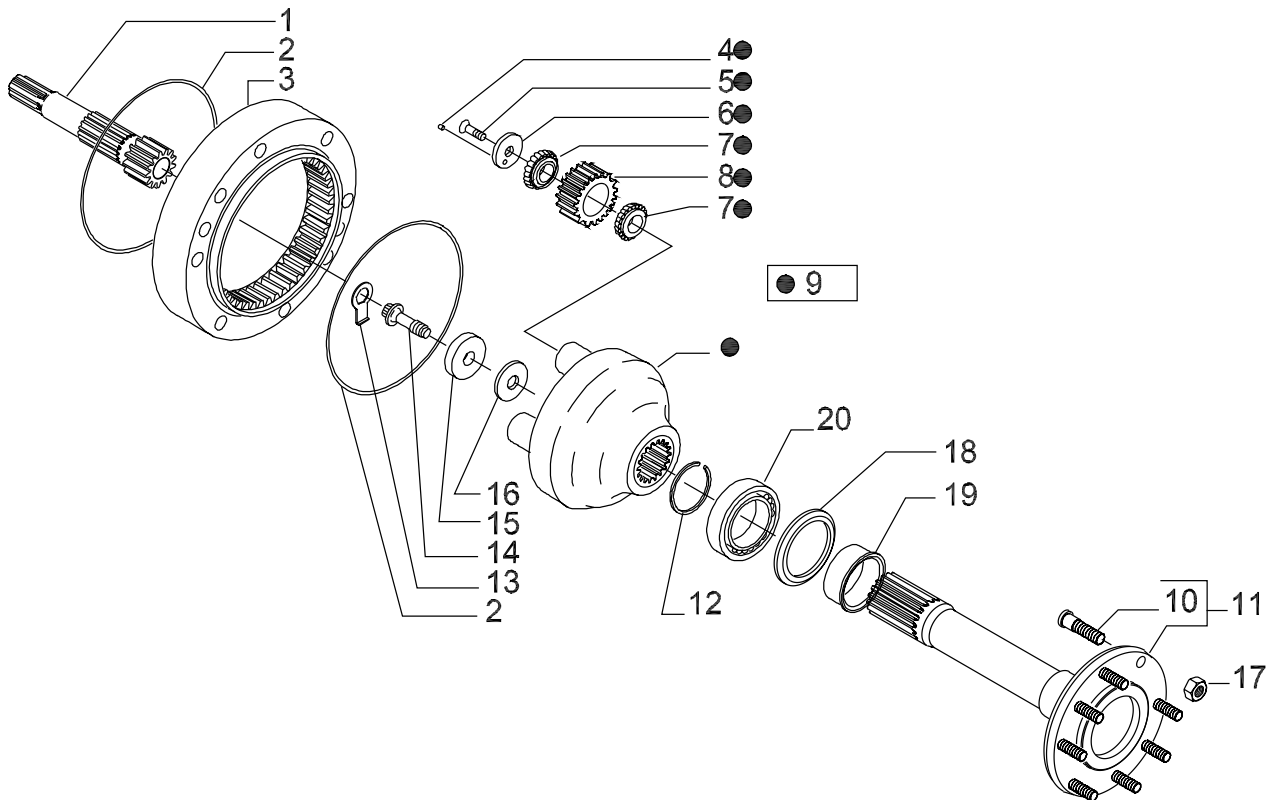

ITEM No.	PART NO.	DESCRIPTION	QTY	REMARKS
1	D10064780	SHAFT HALF WITH GR	2	
2	D10064790	SEAL O RING	4	
3	D10064800	RING GR EPIC Z82	2	
4	D10081650	WASHER	6	
5	D10065690	SCREW	6	
6	2670329AA	WASHER	6	
7	D10081660	BRG	12	
8	D10081670	GR EPICYCLIC (Z-33)	6	
9	D10081680	CARRIER ASSY PLANETARY GR	2	
10	D10081690	BOLT REAR WHL	16	
11	D10081700	SHAFT ASSY WHL	2	
12	D10064820	RING LOCK	2	
13	D10064830	STOP SCREW	2	
14	D10064840	SPECIAL BOLT M16X2	2	
15	D10064850	WASHER	2	
16	D10064860	SHIM 01MM	AR	
16	D10064870	SHIM 03MM	AR	
16	D10064880	SHIM 05MM	AR	
16	D10064890	SHIM 005MM	AR	
17	D10043020	NUT REAR WHL BOLT	16	
18	D10064900	SEAL	2	
19	D10064910	BUSH	2	
20	D10064750	BRG	2	

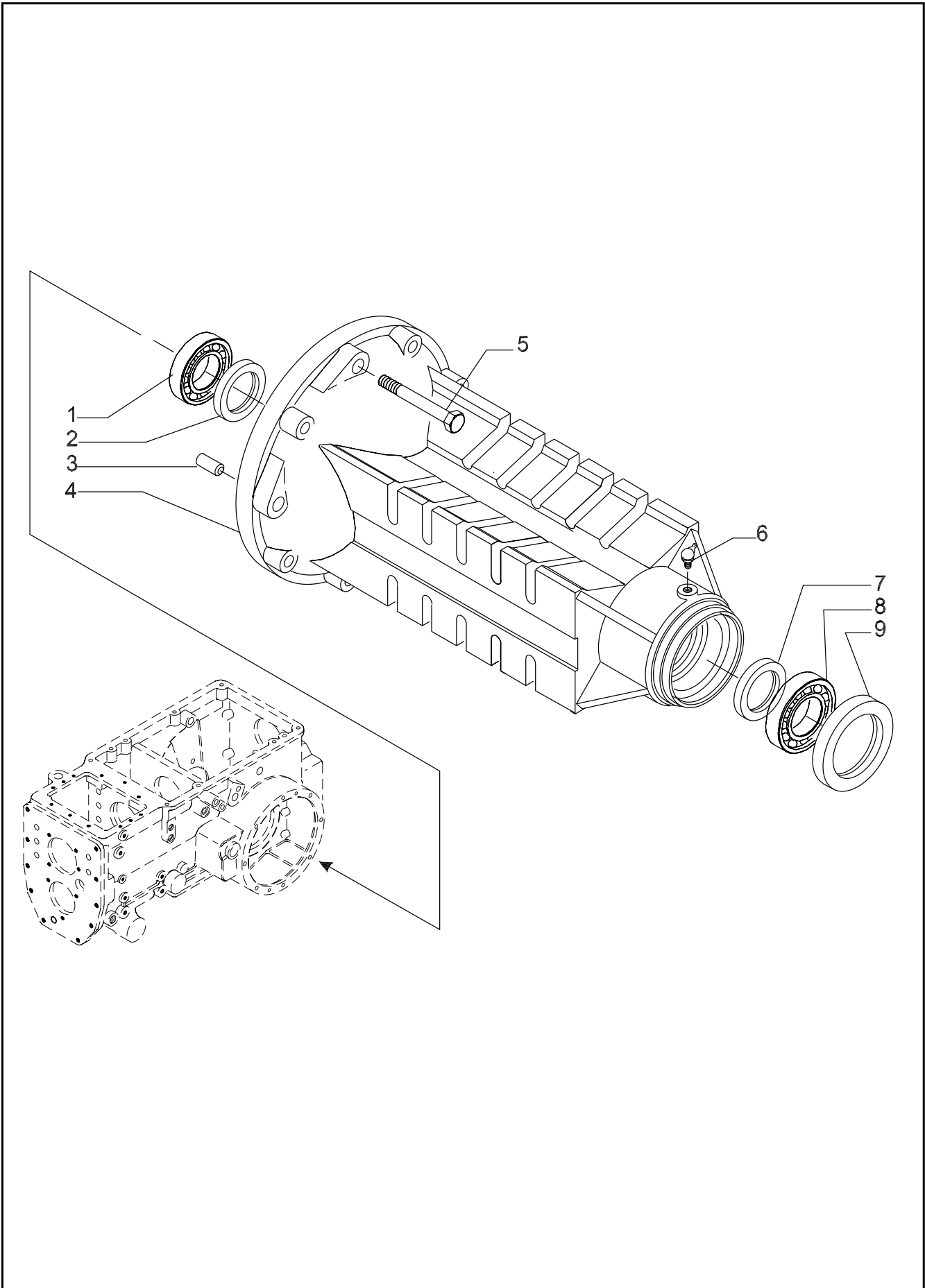

ITEM No.	PART NO.	DESCRIPTION	QTY	REMARKS
1	D10064720	BRG	2	
2	D10064710	SEAL	2	
3	D10064730	PIN D15x75	4	
4	D10081600	KIT REAR AXLE SHAFT HSG (CIL)	2	
5	D81500950	BOLT M14X100	16	
6	D92500080	GREASE NIPPLE M8X1	2	
7	D10064740	SEAL	2	
8	D10064750	BRG	2	
9	D10064760	SEAL	2	

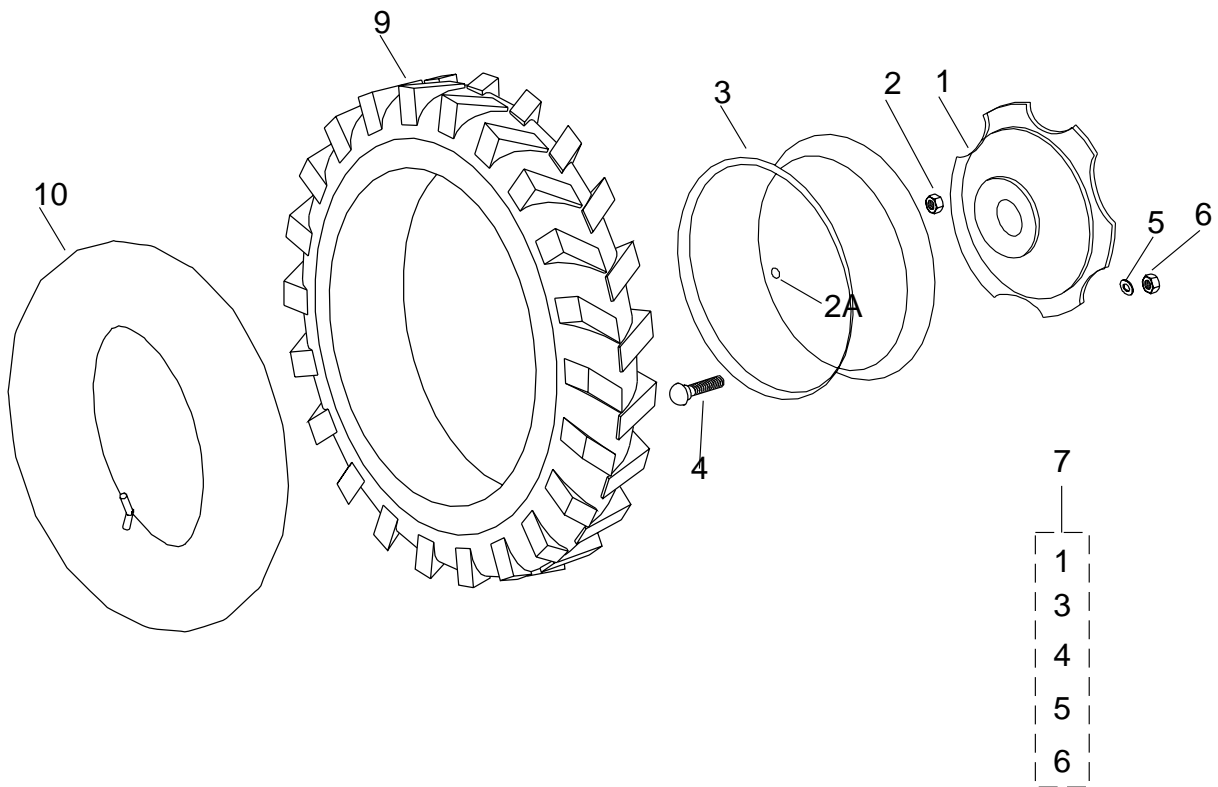

ITEM No.	PART NO.	DESCRIPTION	QTY	REMARKS
1	-	DISC - REAR WHL	2	
2	D10043020	NUT REAR WHL BOLT	16	
3	-	RIM - REAR WHL	2	
4	D10107160	BOLT REAR WHL	12	
5	D10059680	WASHER REAR WHL DISC	12	
6	D10107170	NUT REAR WHL	12	
7	D10109500	WASHER REAR WHL NUT (FT70)	16	
8	D10039230	REAR WHL ASSY W15Lx28 W/O PRIMER	2	

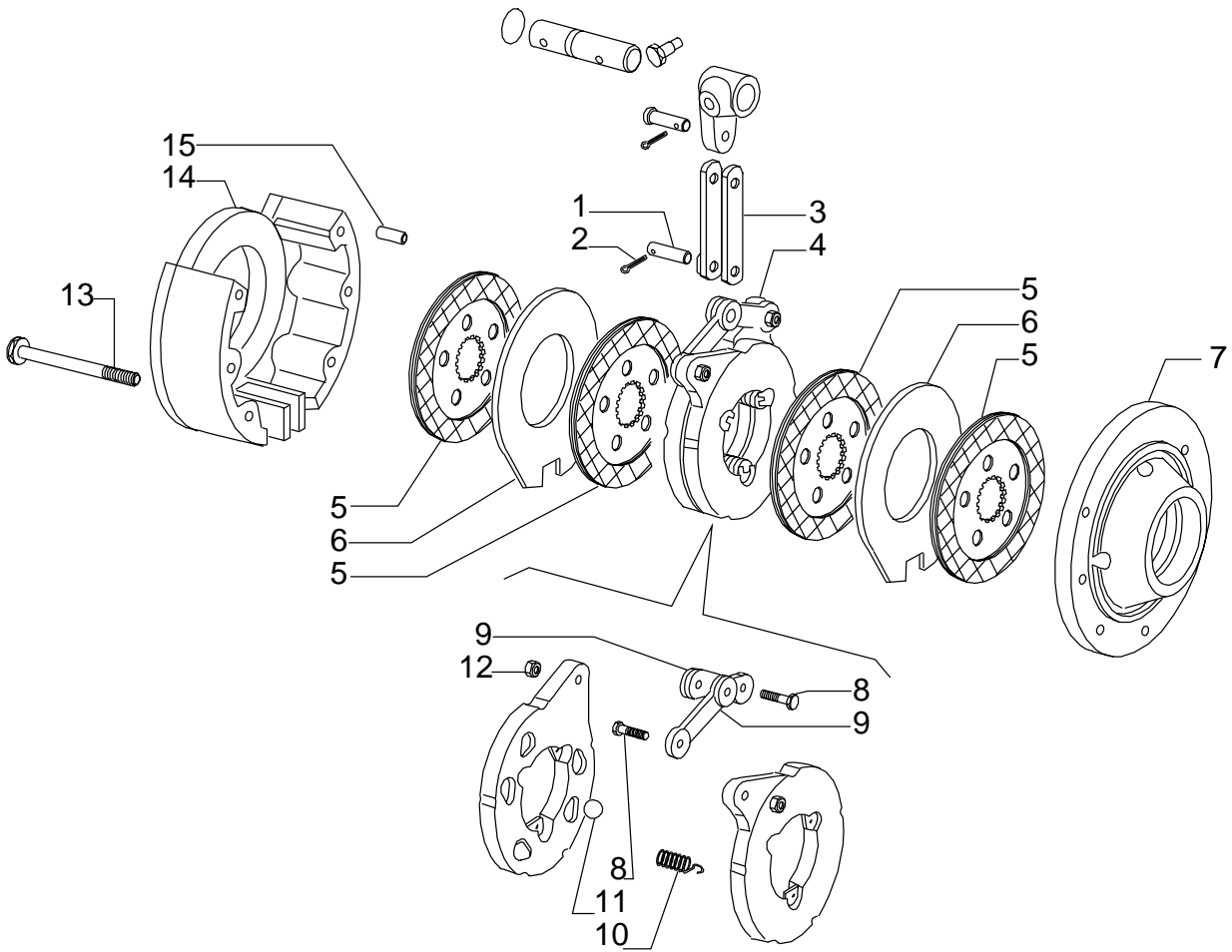

ITEM No.	PART NO.	DESCRIPTION	QTY	REMARKS
1	D10064930	PIN D11	2	
2	D93400240	SPLIT PIN D32X32	2	
3	D10081710	TIE BAR	2	
4	D10064940	BRK MECHANISM	2	
5	D10064950	BRK DISC	8	
6	D10064960	PLATE BRK DRIVE	4	
7	D10064970	SUPPORTING FLANGE	2	
8	2670349AA	BOLT	4	
9	2670350AA	TIE ROD	4	
10	D10103960	SPRING	6	
11	D10103970	BALL	10	
12	D10098140	NUT	4	
13	D81500910	BOLT M12X110	10	
14	D10064980	FLANGE BRKS	2	
15	D10064990	PIN D12X50	4	

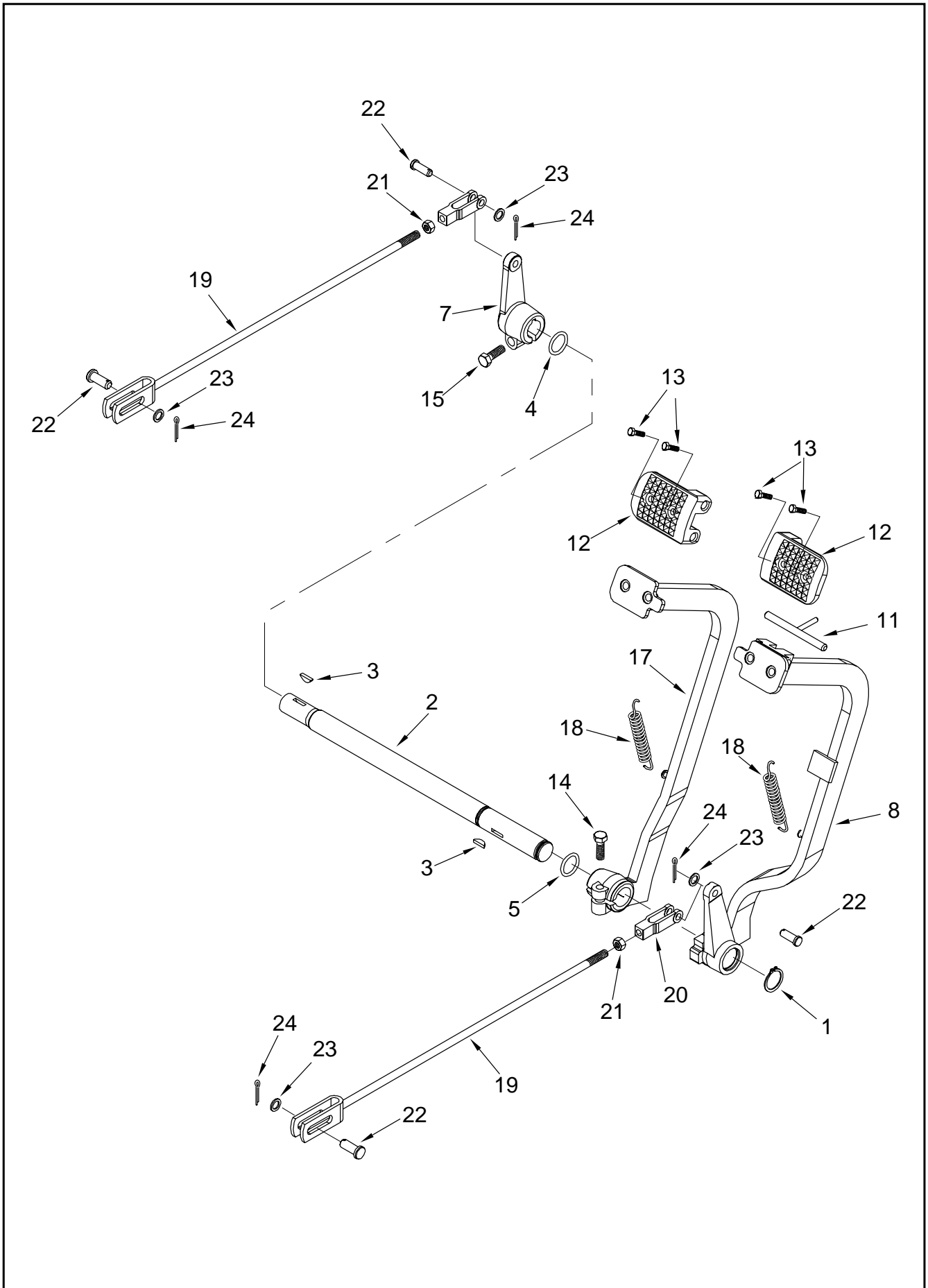

ITEM No.	PART NO.	DESCRIPTION	QTY	REMARKS
1	D10012470	RING CLUCH AND BRK CROSS SHAFT LOCK	1	
2	D10046030	SHAFT BRK PDL FT80	1	
3	D91000070	KEY 1/4"x7/8" WOODRUFF	2	
4	D10012260	WASHER BRK PDL CROSS SHAFT THRUST	3	
4a	D10012480	WASHER BRK PDL CROSS SHAFT THRUST	1	
5	D93600080	SEAL O RING 0.139"x1.125"	4	
7	D10042490	LEVER BRK OPERATING LH	1	
8	D10046000	PDL ASSY BRK RH	1	
9	D10002040	BUSH BRK PDL SHAFT	1	NI,
10	D92500050	GREASE NIPPLE 1/4"-28 STRAIGHT FITTING	1	
11	D10042290	LATCH ROD	1	
12	D10042840	PAD PDL	2	
13	D81501020	BOLT M8x1.25x35-8.2 HEX HEAD	4	
14	D81000460	BOLT 7/16"-14x1.38" HEX HEAD	2	
15	D81000470	BOLT 7/16"-14X1.50" HEX HEAD	1	
16	D10013460	PIN 1/8"x0.75" COTTER	4	
17	D10046010	PDL ASSY BRK LH	1	
18	D10012250	SPRING BRK PDL RETURN	2	
19	D10042790	ROD ASSY BRK LINK	2	
20	D93400060	CLEVIS 10x47.62 ADJUSTABLE	2	NSS-25
21	D83000010	NUT 3/8-24 HEX	2	
22	D93400080	PIN 12x30.8 CLEVIS	4	
23	D85500160	WASHER M12 FLAT	4	
24	D88400080	PIN 5/32"x1.75" COTTER	4	
25	D10017720	ROD AND CLEVIS ASSY BRK CONTROL	2	

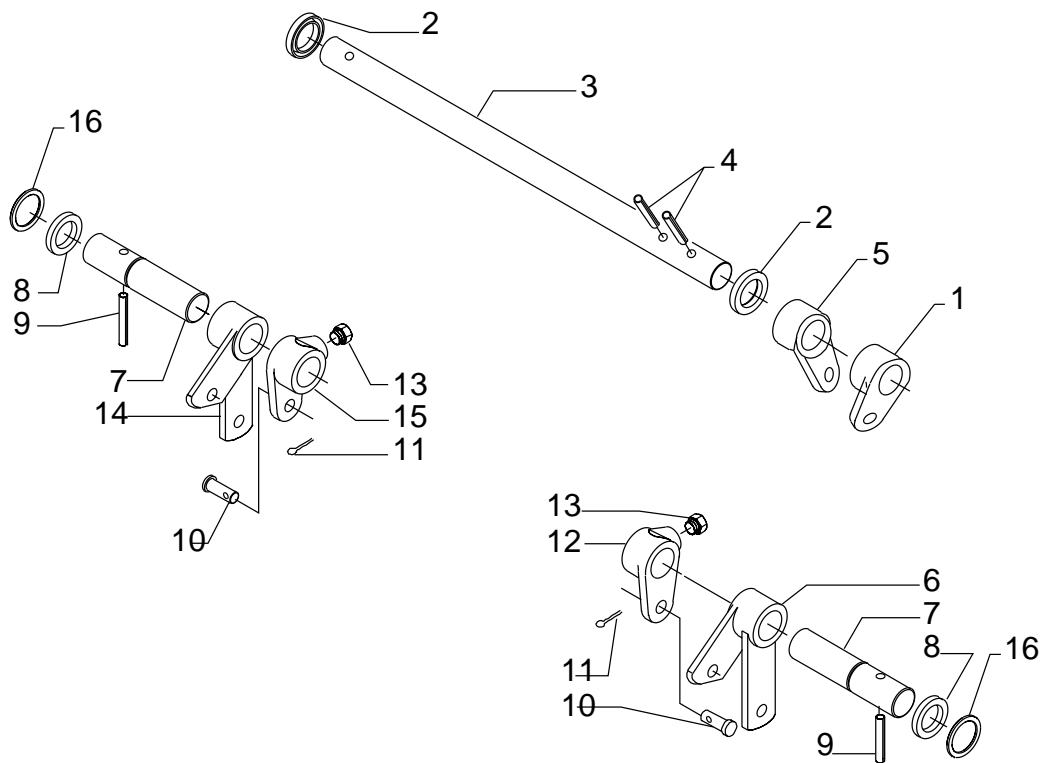

ITEM No.	PART NO.	DESCRIPTION	QTY	REMARKS
1	D10065000	LEVER BRKS	2	
2	D10063500	SEAL OIL	2	
3	D10065020	SHAFT HAND BRK	1	
4	D10065030	PIN D8X36	3	
5	D10065040	LEVER HAND BRK	1	
6	D10065050	LEVER BRK LH	1	
7	D10065060	BRK SHAFT	2	
8	D10065070	SEAL RING	2	
9	D10065090	PIN 10X45	2	
10	D10065100	PIN D11	2	
11	D93400240	SPLIT PIN D32X32	2	
12	D10065110	LEVER (DX)	1	
13	D10065120	BOLT SPECIAL	2	
14	D10065130	LEVER BRK RH	1	
15	D10065140	LEVER (LH)	1	
16	D10065150	WASHER THRUST	2	

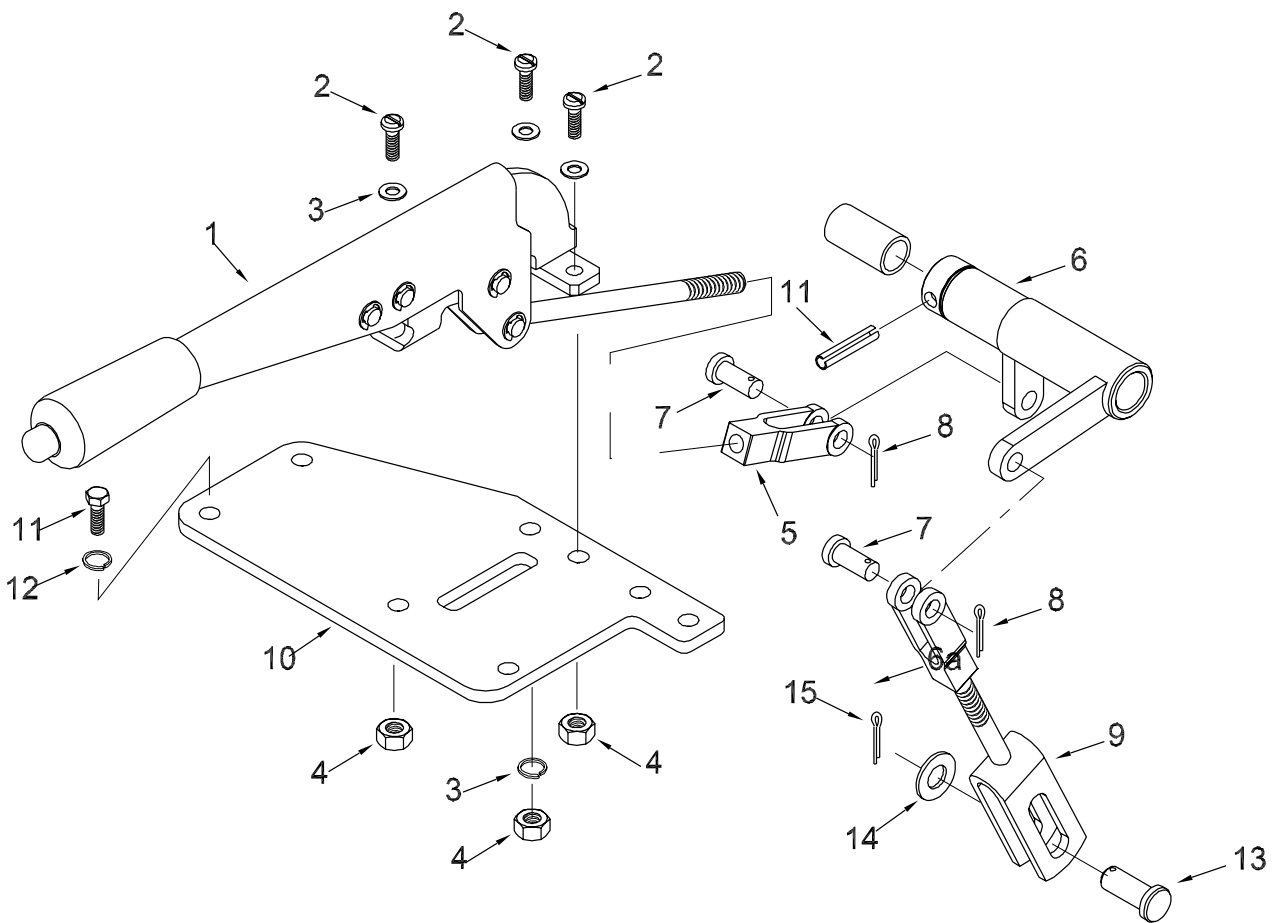

ITEM No.	PART NO.	DESCRIPTION	QTY	REMARKS
1	D10042050	LEVER ASSY PARKING BRK	1	
1a	D10042060	LEVER PARKING BRK RH	1	
2	D81500490	BOLT M6x1.0x20-6G HEX HEAD	3	
3	D85500110	WASHER M6 FLAT	3	
4	D83500220	NUT M6x1.00-5 HEX	3	
5	D10102360	CLEVIS 3/8"	1	
6	D10042040	SHAFT PARKING BRK EXTENSION	1	
6a	D10042980	BUSH	1	
7	D93400030	PIN 3/8"x1.14" CLEVIS	2	
8	D10013460	PIN 1/8"x0.75" COTTER	2	
9	D10042820	ROD AND CLEVIS ASSY	2	
10	D10042210	BRACKET PARKING BRK	1	
11	D81500310	BOLT M8x1.25x30 HEX HEAD	2	
12	D86500150	WASHER M8 SPRING LOCK	2	
13	D93400080	PIN 12x30.8 CLEVIS	1	
14	D85500160	WASHER M12 FLAT	1	
15	D87000100	PIN 5/32"x1.25" COTTER	1	

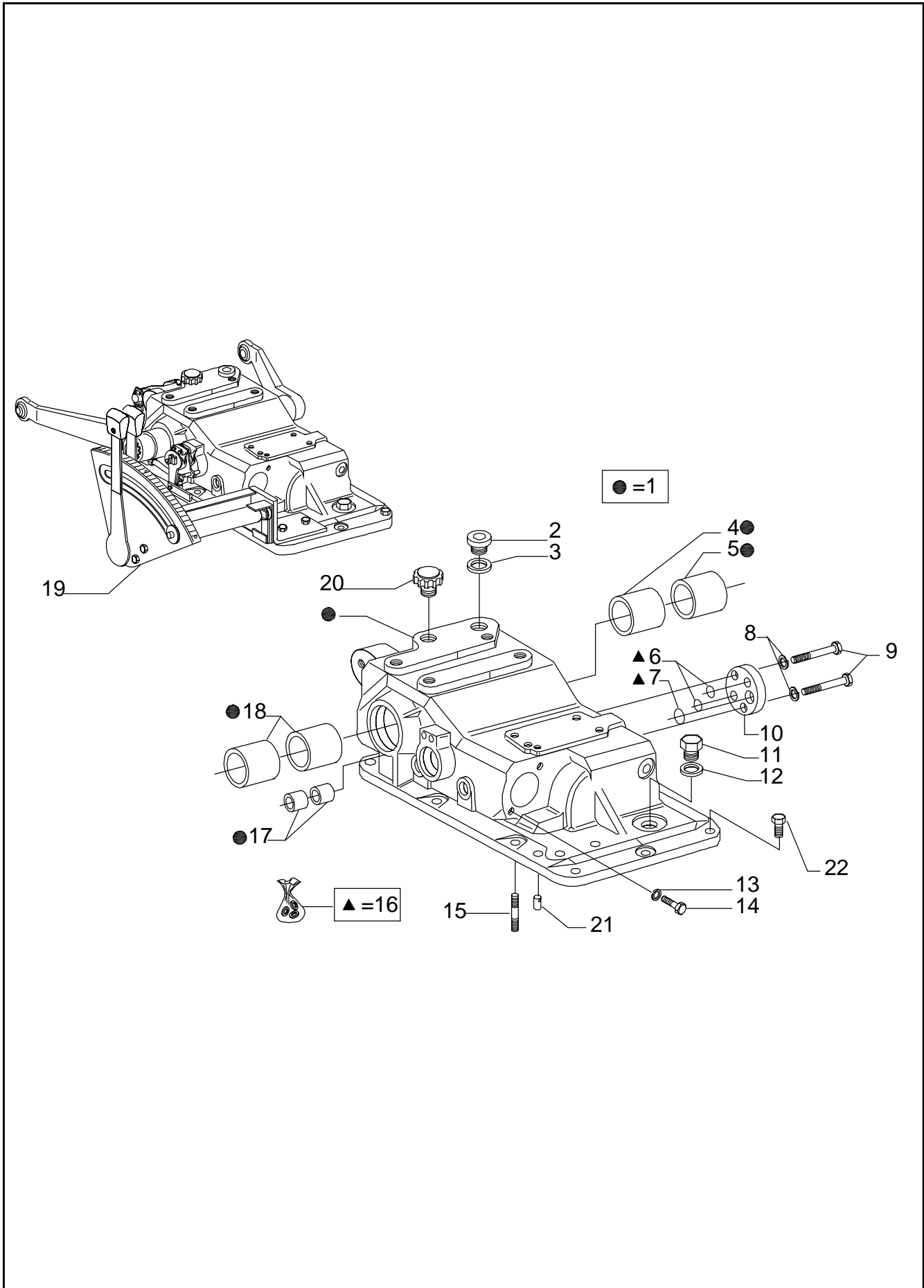

ITEM No.	PART NO.	DESCRIPTION	QTY	REMARKS
1	D10039490	LIFT ASSY HYD	1	
2	D10062150	PLUG 1/2"	1	
3	D10062220	WASHER	1	
4	D10061580	BUSH	1	
5	D10061530	BUSH	1	
6	D10061540	SEAL O RING	2	
7	D10103980	O RING	1	
8	D10061350	WASHER SPLIT	2	
9	D81500880	BOLT M10x1.5x35-8.8 HEX HEAD	2	
10	D10098050	FLANGE	1	
11	D10039720	ADAPTER RETURN	1	
12	D10061420	WASHER COPPER SEALING	1	
13	D86500150	WASHER M8 SPRING LOCK	2	
14	D81501080	BOLT M8x1.25x35	2	
15	D10098080	STUD M14x61	6	
16	D10098110	KIT SEAL	1	KIT
17	D10062160	BUSH	2	
18	D10061510	BUSH	2	
19	D10039490	LIFT ASSY HYD	1	
20	D10081720	PLUG	1	
21	D10064240	PIN 12x30	2	
22	D81500920	BOLT M12x30	9	
23	D10043150	ELBOW HYD PUMP	1	
23a	D10044180	ADAPTER HYD LIFT INL	1	
24	D10042180	BRACKET ASSY LEVER GUIDE	1	
25	D83500290	NUT M12x1.75 HEX	1	
26	D93600070	SEAL O RING 0.087"x0.644"	1	

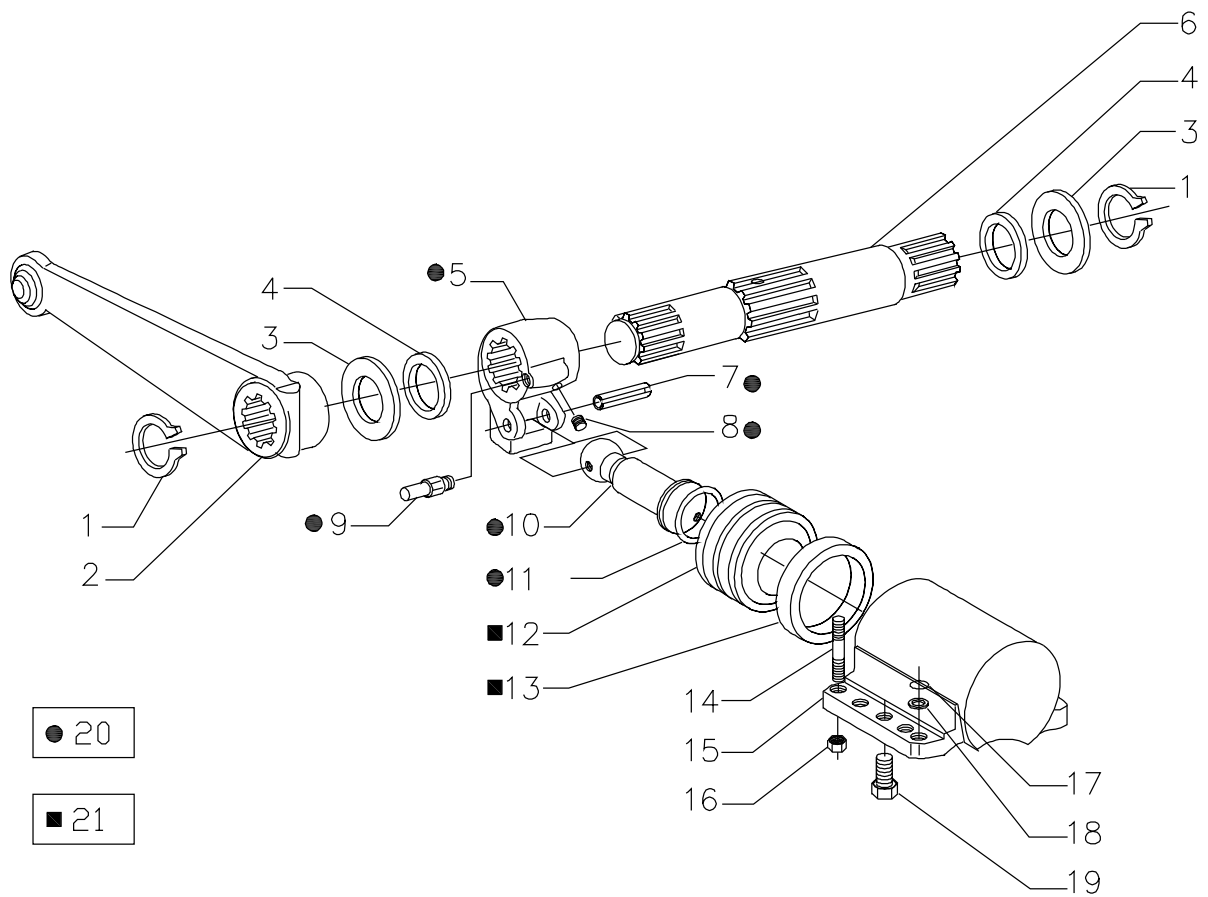

ITEM No.	PART NO.	DESCRIPTION	QTY	REMARKS
1	D90000350	RING SNAP D55	2	
2	D10062510	ARM LIFTING	2	
3	D10067440	SPACER	2	
4	D10061850	SEAL OIL	2	
5	D10062040	LEVER	1	
6	D10062060	SHAFT LIFTING	1	
7	D93400260	PIN 10x65 COTTER	1	
8	D10062180	GRUB M10x20	1	
9	D10062050	PIN	1	
10	D10062030	ROD CONNECTING	1	
11	D10061520	SEAL O RING	1	
12	D10062020	PISTON	1	
13	D10062170	PACKING PISTON	1	
14	D10098080	STUD M14x61	6	
15	D10061990	CYLINDER	1	
16	D83500470	NUT M14	6	
17	D10061540	SEAL O RING	1	
18	D10105290	RING	1	
19	D81500960	BOLT M14x35	2	
20	D10098120	KIT LEVER AND CON ROD	1	KIT
21	D10081730	PISTON AND RING ASSY	1	

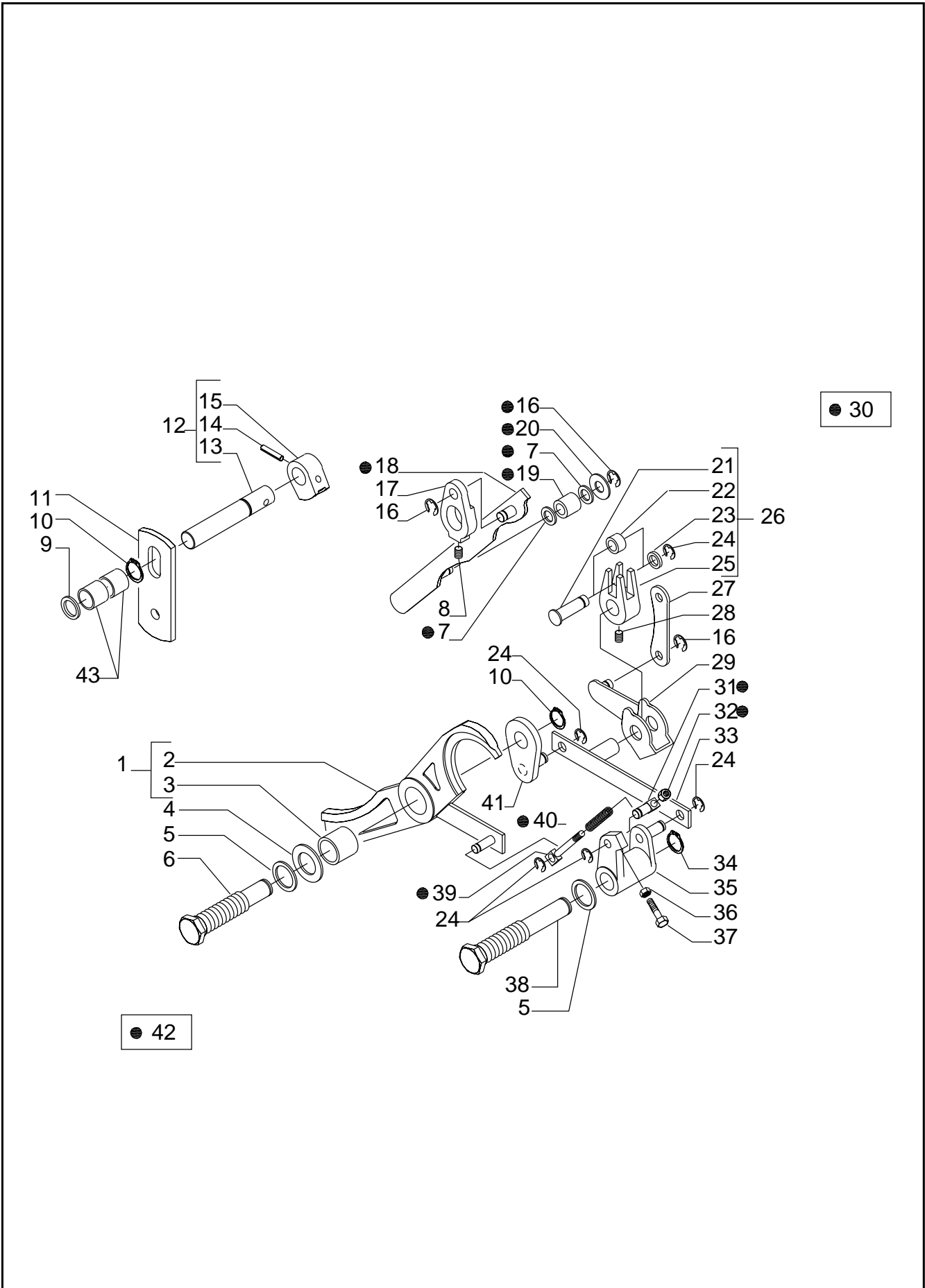

ITEM No.	PART NO.	DESCRIPTION	QTY	REMARKS
1	D10099090	EQUILIZER	1	
2	D10067450	EQUALIZER	1	
3	D10105030	BRG	1	
4	D10099150	WASHER	1	
5	D10061420	WASHER COPPER SEALING	2	
6	D10067430	PIN SUPPORT	1	
7	D10099140	WASHER	2	
8	D10067350	GRUB M8x9	1	
9	D10067330	RING SEAL	1	
10	D90000330	RING SNAP	2	
11	D10067340	PLATE	1	
12	D10099120	CAM	1	
13	D10067460	SHAFT	1	
14	D10063900	BUSH	1	
15	D10111110	CAM CONTROL VALVE	1	
16	D90000340	RING SNAP D16	3	
17	D10067360	CAM	1	
18	2605477AA	PLATE	1	
19	D10067370	WASHER	1	
20	D10067310	WASHER	1	
21	D10067380	PIN	1	
22	D10067390	WASHER	1	
23	D10067320	WASHER	1	
24	D10099080	RING SNAP	5	
25	D10067400	ROD CONNECTING	1	
26	D10099130	ROD CONNECTING	1	
27	D10067480	ROD LINK	1	
28	D10067420	SCREW M8x12 GRUB	1	
29	D10067470	CAM	1	
30	D10099110	PLATE	1	
31	D10067500	SHAFT	1	
32	D83500220	NUT M6x1.00-5 HEX	1	
33	D10067510	PLATE	1	
34	D90000180	CIRCLIP A15x0.90 SB	1	
35	D10067520	LEVER	1	
36	D83500230	NUT M8x1.25-5 HEX	1	
37	D81501050	BOLT M8x1.25x25	1	
38	D10067550	PIN SUPPORT	1	
39	D10067570	PIN	1	
40	D10067610	SPRING	1	
41	D10067620	SHACKLE	1	
42	D10105370	SPRING (PRE ASSEMBLED)	1	
43	D10062160	BUSH	2	

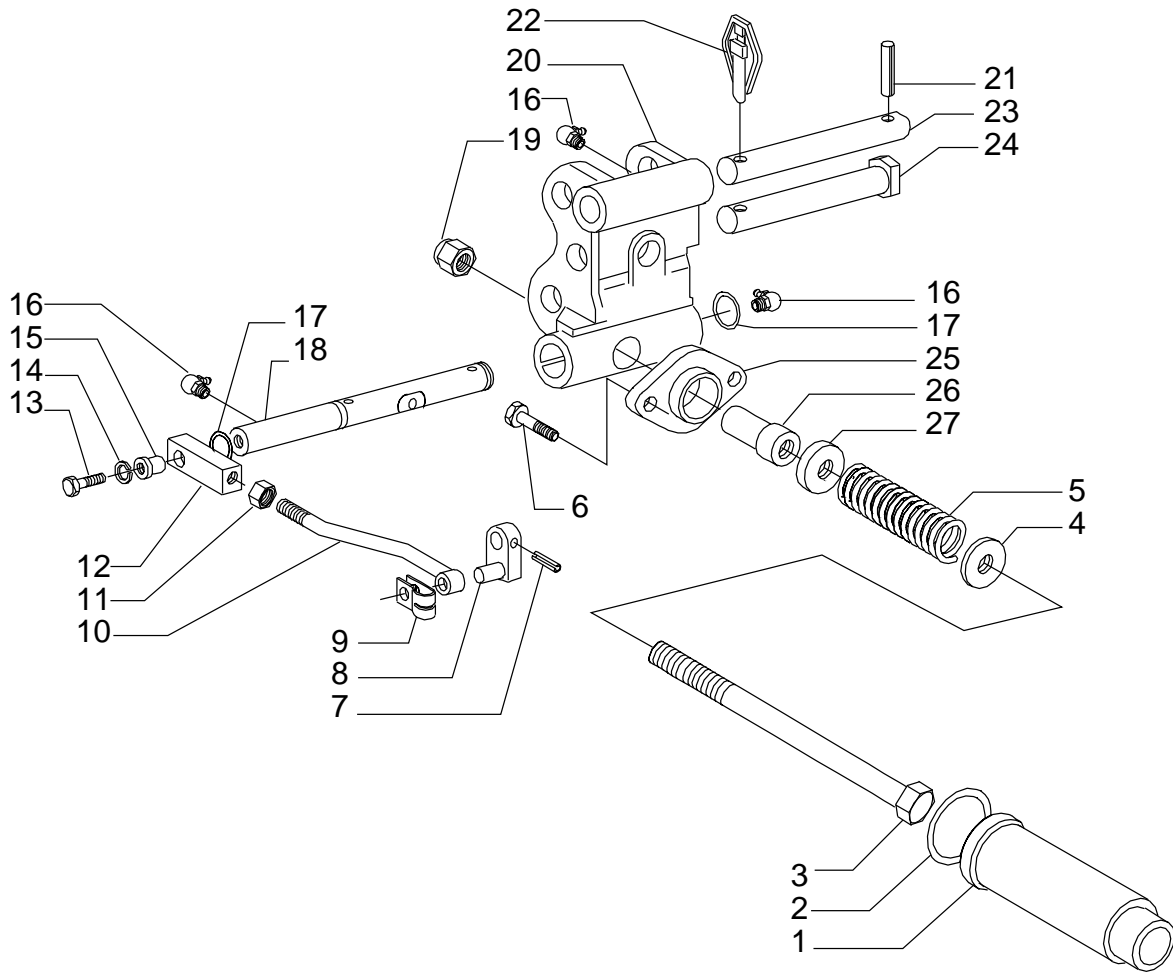

ITEM No.	PART NO.	DESCRIPTION	QTY	REMARKS
1	D10061640	CVR SPRING	1	
2	D10061700	SEAL O RING	1	
3	D10062190	ROD	1	
4	D10061710	WASHER	1	
5	D10062480	SPRING	1	
6	D81500560	BOLT M12x1.75x30-6G HEX HEAD	2	
7	D10064610	PIN 6x28 COTTER	1	
8	D10062430	LEVER	1	
9	D10061790	WASHER LOCK	1	
10	D10062070	ROD	1	
11	D83000130	NUT #10-24 HEX	1	
12	D10061800	PLATE	1	
13	D81501080	BOLT M8x1.25x35	1	
14	D86500150	WASHER M8 SPRING LOCK	1	
15	D10061840	BUSH	1	
16	D92500060	GREASE NIPPLE M10x1-45DEGREE	3	
17	D10061460	SEAL O RING	2	
18	D10062090	SHAFT	1	
19	D83500470	NUT M14	1	
20	D10061500	BRACKET 3RD POINT	1	
21	D10063900	BUSH	2	
22	D10098130	PIN DIA-10mm LOCK	1	
23	D10062410	PIN 3RD POINT	1	
24	D10098090	PIN 3RD POINT	1	
25	D10061730	FLANGE	1	
26	D10062420	BUSH	1	
27	D10061740	WASHER	1	

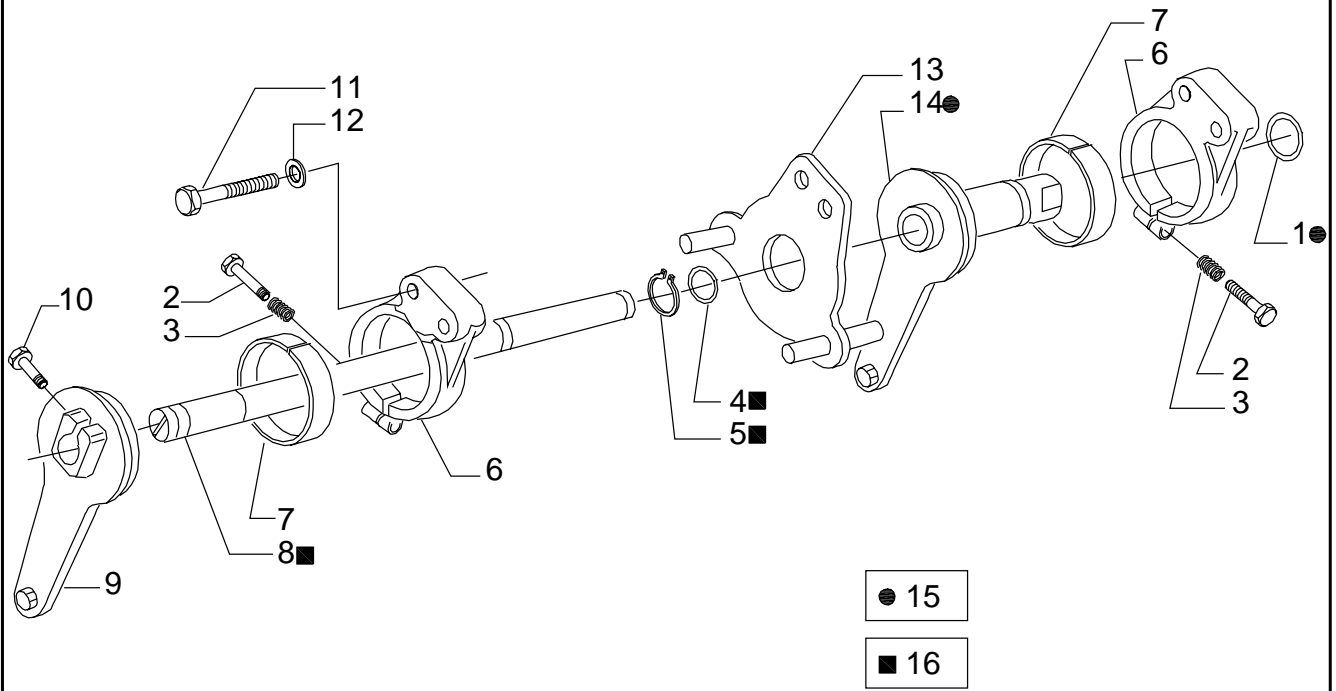

ITEM No.	PART NO.	DESCRIPTION	QTY	REMARKS
1	D10061450	SEAL O RING	1	
2	D81501010	BOLT M6x40	2	
3	D10061600	SPRING	2	
4	D10061540	SEAL O RING	1	
5	D90000340	RING SNAP D16	1	
6	D10061630	SUPPORT	2	
7	D10061590	RING CL	2	
8	D10062110	SHAFT POSITION DRIVE	1	
9	D10062120	LEVER	1	
10	D10103670	BOLT M10x1.25x30 HEX	1	
11	D81501100	BOLT M8x1.25x55	2	
12	D86500150	WASHER M8 SPRING LOCK	2	
13	D10062200	FLANGE	1	
14	D10062390	SHAFT STRESS DRIVE	1	
15	D10116880	SHAFT DRIVE STRESS (CIL PART NO 046488)	1	KIT
16	2605430AA	DRIVE SHAFT [PRE-ASSEMBLED]	1	

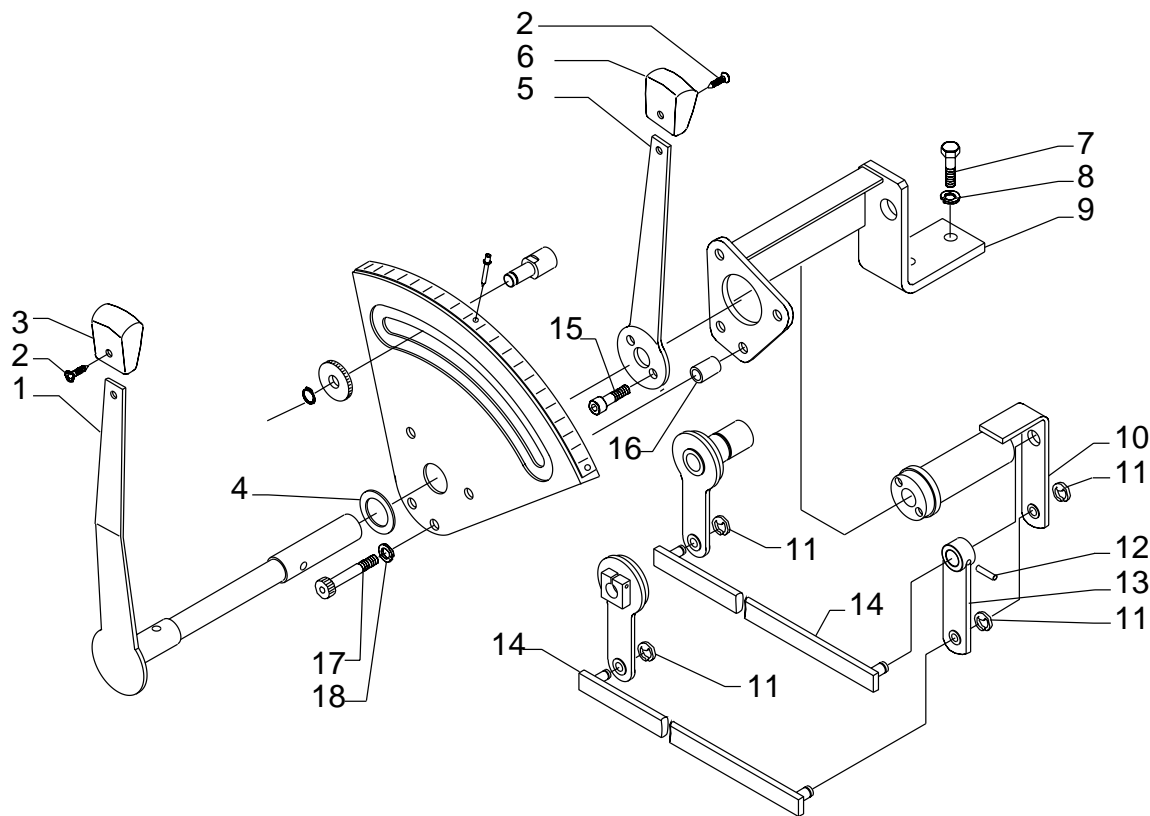

ITEM No.	PART NO.	DESCRIPTION	QTY	REMARKS
1	D10061490	LEVER DRIVE	1	
2	D82500380	SCREW M35x13	2	
3	D10043470	KNOB HYD CONTROL LEVER (YELLOW)	1	
4	D10062330	WASHER	1	
5	D10098040	LEVER DRIVE	1	
6	D10043460	KNOB HYD CONTROL LEVER (RED)	1	
7	D81500280	BOLT M10x1.50x25-6G HEX HEAD	2	
8	D10061350	WASHER SPLIT	2	
9	D10062490	SUPPORT	1	
10	D10062130	SHAFT DRIVE	1	
11	D10081740	RING SNAP	4	
12	D93400250	PIN 6X25 COTTER	1	
13	D10062140	LEVER	1	
14	D10062140	LEVER	2	
15	D81500360	BOLT M6x1.00x16-6G HEX HEAD	2	
16	D10098060	SPACER	4	
17	D81501020	BOLT M8x1.25x35-8.2 HEX HEAD	4	
18	D86500150	WASHER M8 SPRING LOCK	4	
19	D10044000	STOP ASSY LIFT CONTROL LEVER	1	

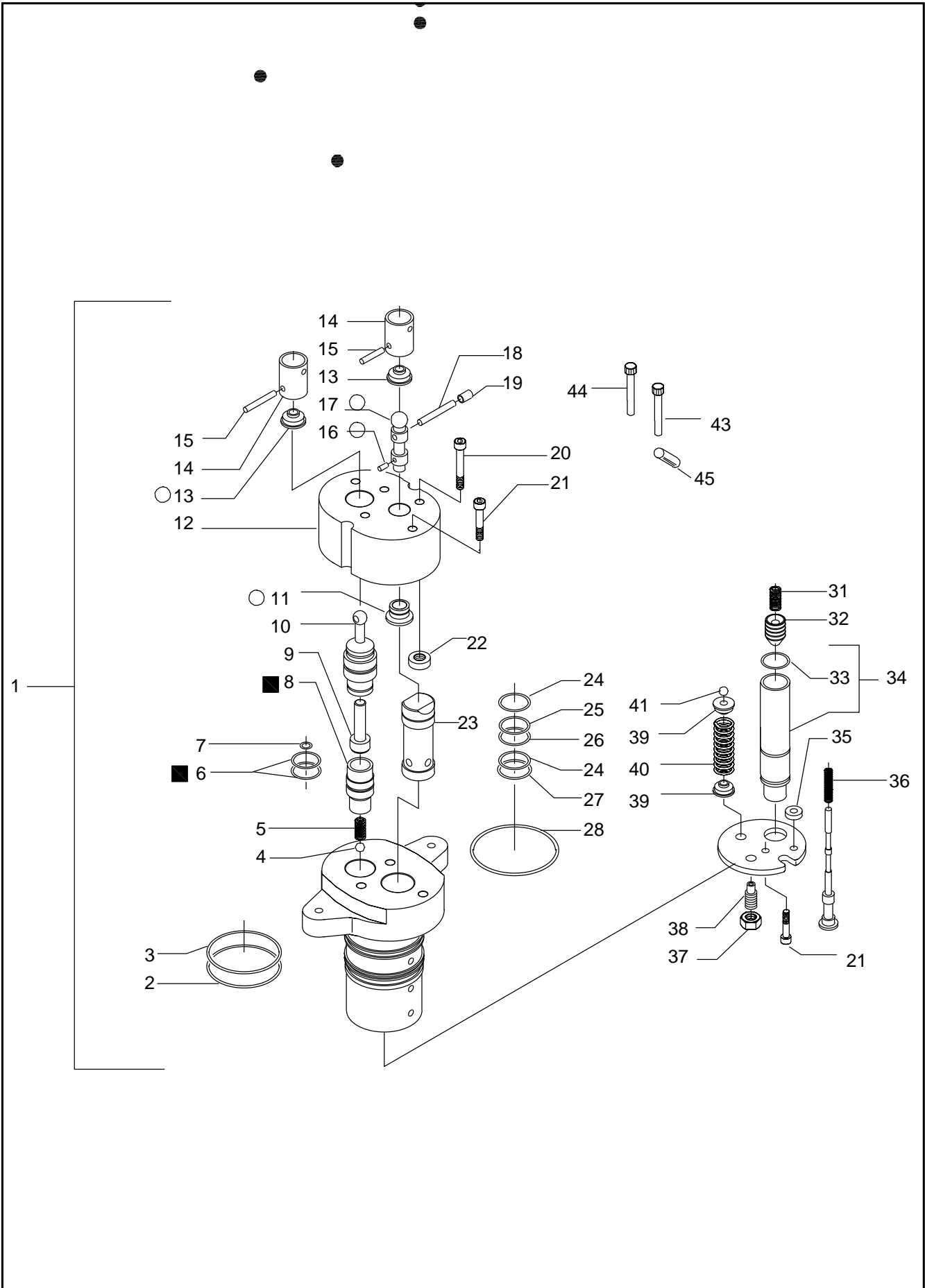

ITEM No.	PART NO.	DESCRIPTION	QTY	REMARKS
1	D10068010	DISTRIBUTOR	1	
2	D10116850	RING (CIL PART NO 046567)	1	
3	D93600340	SEAL O RING (CARRARO PART NO 046731)	2	
4	D10119690	BALL 11/32" (CIL PART NO 046724)	1	
5	D10119680	SPRING (CIL PART NO 046723)	1	
6	D93600350	SEAL O RING (CARRARO PART NO 046721)	2	
7	D93600390	SEAL O RING (CARRARO PART NO 46720)	1	
8	D10116190	SEAL BLOCK (CARRARO PART NO 046484)	1	
9	2605491AA	PISTON	1	
10	2605490AA	PUSH ROD	1	
11	2605537AA	RING NUT	1	
12	D10116160	RING NUT (CARRARO PART NO 046882)	1	
13	D10105370	SPRING (PRE ASSEMBLED)	2	
14	2605539AA	JOINT	2	
15	2605416AA	SPLIT PIN	2	
16	D10116170	PIN (CARRARO PART NO 046885)	2	
17	D10116180	ROD PUSH (CARRARO PART NO 046886)	1	
18	2605417AA	SPLIT PIN	1	
19	2605567AA	CAP	1	
20	D81500360	BOLT M6x1.00x16-6G HEX HEAD	2	
21	D81500270	BOLT M6x1.00x25-6G HEX HEAD	5	
22	2605543AA	BUSH	2	
23	2605544AA	VALVE	1	
24	D93600380	SEAL O RING (CARRARO PART NO 46727)	2	
25	D93600430	SEAL O RING (CARRARO PART NO 46728)	1	
26	D93600410	SEAL O RING (CARRARO PART NO 46729)	1	
27	D93600420	SEAL O RING (CARRARO PART NO 46564)	1	
28	D93600400	SEAL O RING (CARRARO PART NO 46730)	1	
29	D10105850	KIT DISTRIBUTOR SENSITIVITY REGULARISATION GROUP	1	KIT
30	D10105860	KIT DISTRIBUTOR BLOCK SEAT ASSY	1	KIT
31	2605451AA	SPRING	1	
32	2605545AA	DIFFERENTIAL VALVE	1	
33	D93600360	SEAL O RING (CARRARO PART NO 046735)	1	
34	2605426AA	DIFFERENTIAL VALVE SEAL ASSY	1	
35	2605450AA	SPRING	2	
36	2605503AA	SPRING	1	
37	D83500080	NUT M10x1.00-8 HEX	2	
38	2605448AA	GRUB M8x16	2	
39	D10116860	GUIDE SPRING (CIL PART NO 046568)	4	
40	D10116870	SPRING (CIL PART NO 046569)	2	
41	D10118330	BALL DIA 5/16" (CARRARO PART NO 046732)	2	
42	D10098070	KIT OIL SEAL	1	KIT
43	D10043420	LEVER AND KNOB ASSY FLOW CONTROL VALVE	1	
44	D10043410	LEVER AND KNOB ASSY FLOW CONTROL VALVE	1	
45	D87000100	PIN 5/32"x1.25" COTTER	2	

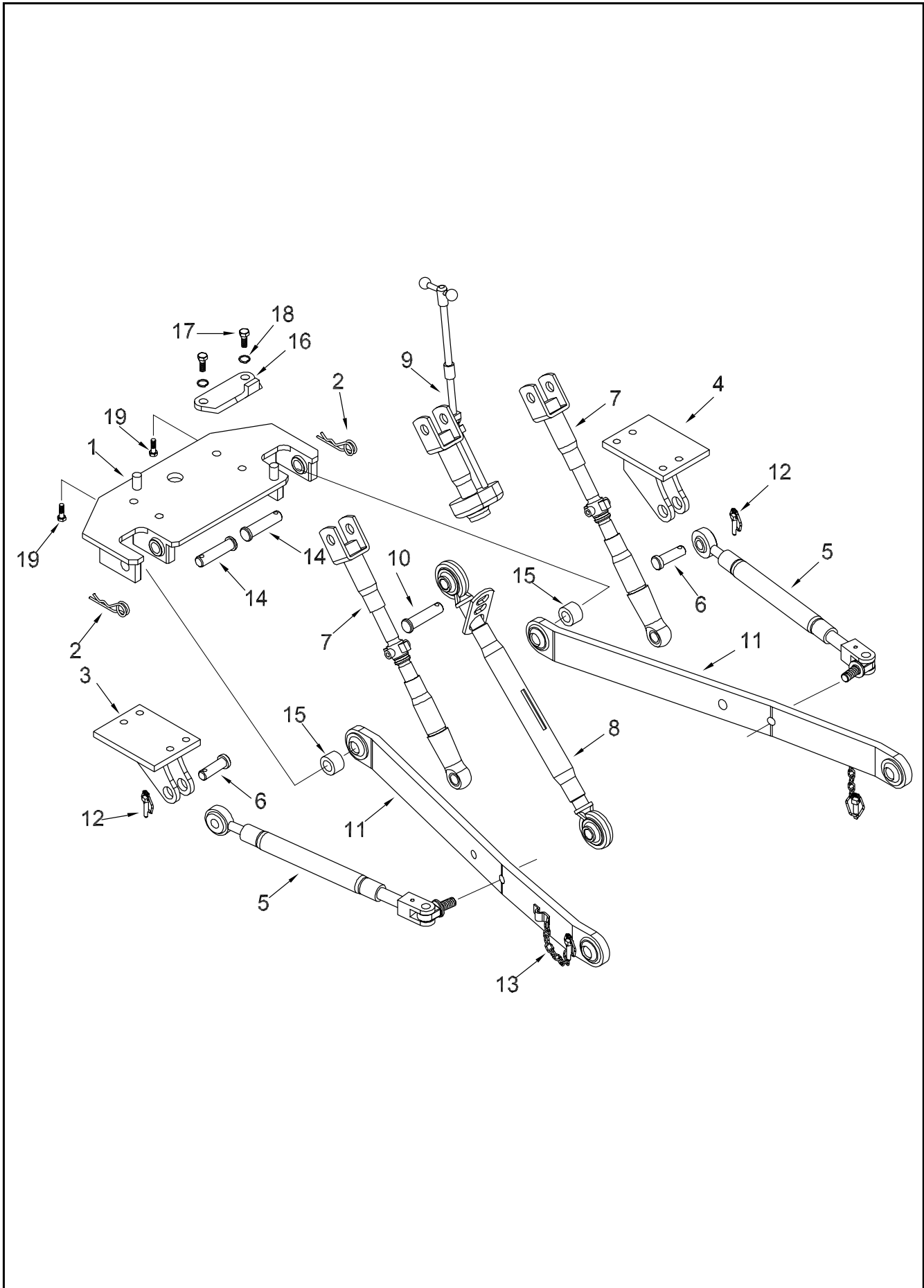

ITEM No.	PART NO.	DESCRIPTION	QTY	REMARKS
1	D10039480	SUPPORT LWR LINK MNTG	1	
2	D87000130	PIN 8x35 SPRING	2	
5	D10039460	BAR ASSY STAY	2	
6	D10043010	PIN	2	
7	D10039440	ROD ASSY HYD LIFT LEVELLING	1	
8	D10039430	LINK ASSY HYD UPR LIFT	1	
9	D10039450	BOX ASSY HYD LIFT LEVELLING	1	
10	D10043230	PIN UPR LINK	2	
11	D10039470	LINK ASSY LWR HYD LIFT	2	
12	D10042600	PIN SAFETY SPLIT	12	
13	D10043220	CHAIN AND CLIP ASSY	4	
14	D10042610	PIN FULCRUM	2	
15	D10042630	SPACER LWR LINK	2	
16	D10042590	BRACKET TOP LINK	1	
17	D81500370	BOLT M10x1.50x30-6G HEX HEAD	2	
18	D86500090	WASHER M10 SPRING LOCK	2	
19	D10042620	SCREW M16 SELF LOCKING	4	
23	D10047760	BRACKET TOP LINK HOLDING	1	NI,
24	D10134630	HANGER TOP LINK HOLDING	1	NI,

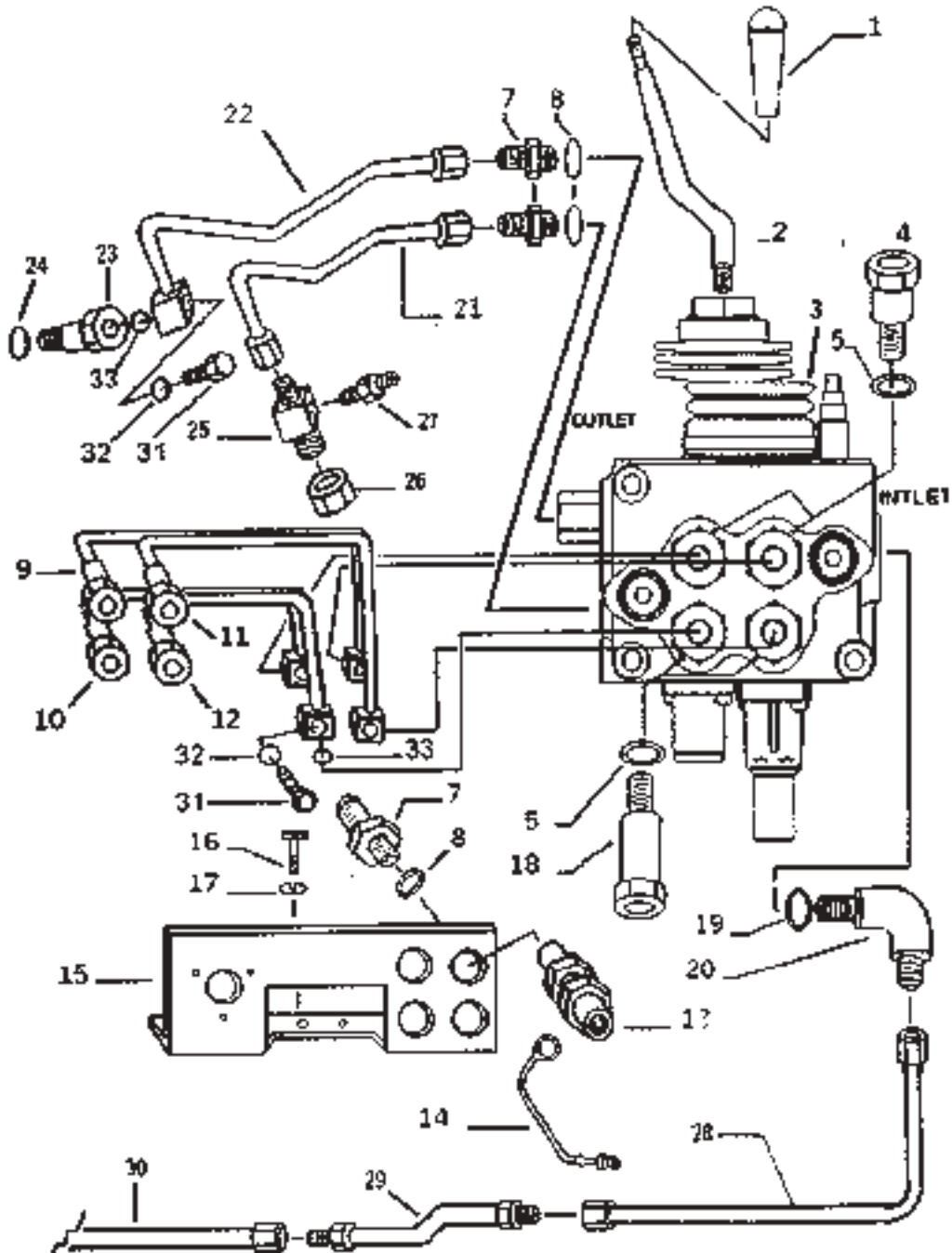

ITEM No.	PART NO.	DESCRIPTION	QTY	REMARKS
1	D10042450	KNOB	1	
2	D10044060	LEVER VALVE HYD CONTROL	1	
3	D10044310	VALVE ASSY HYD CONTROL DOUBLE SPOOL	1	
4	D10044150	ADAPTER VALVE HYD CONTROL	2	
5	D93600110	SEAL O RING 0.103"x0.437"	4	
6	D10044230	TUBE ASSY SPOOL VALVE INL-CDS	1	
7	D10044040	CONNECTOR	6	
8	D93600070	SEAL O RING 0.087"x0.644"	6	
9	D10044110	TUBE ASSY HYD CONTROL VALVE LWR LH-CDS	1	
10	D10044090	TUBE ASSY HYD CONTROL VALVE UPR LH-CDS	1	
11	D10044100	TUBE ASSY HYD CONTROL VALVE UPR RH-CDS	1	
12	D10044120	TUBE ASSY HYD CONTROL VALVE LWR RH-CDS	1	
13	D10026100	COUPLING ASSY VALVE HYD REMOTE	2	
13a	D10026110	COUPLING ASSY VALVE HYD REMOTE	2	
14	D10105250	PLUG DUST (BLUE)	4	
15	D10044170	BRACKET COUPLING MNTG	1	
16	D81500370	BOLT M10x1.50x30-6G HEX HEAD	2	
17	D86500090	WASHER M10 SPRING LOCK	2	
18	D10044160	ADAPTER VALVE HYD CONTROL	2	
19	D10044200	WASHER SEALING	7	
20	D10044030	ELBOW SPOOL VALVE	1	
21	D10044220	TUBE ASSY SPOOL VALVE TO HSG-CDS	1	
22	D10044210	TUBE ASSY SPOOL VALVE TO HYD LIFT-CDS	1	
23	D10044180	ADAPTER HYD LIFT INL	1	
24	D10044190	WASHER SEALING	1	
25	D10039720	ADAPTER RETURN	1	
26	D10042150	NUT LOCK	1	
27	D10021160	CONNECTER 1/2" FLX 3/4"-16 STRAIGHT THREAD	1	
28	D10043130	EXTENSION TUBE RETURN TO HSG-CDS	1	
29	D10044260	TUBE ASSY TAP OFF-CDS	1	
31	D10027150	BOLT HYD REMOTE CONTROL HOSE FITTING	5	
32	D93600070	SEAL O RING 0.087"x0.644"	5	
33	D10027170	SEAL CONTROL VALVE	5	

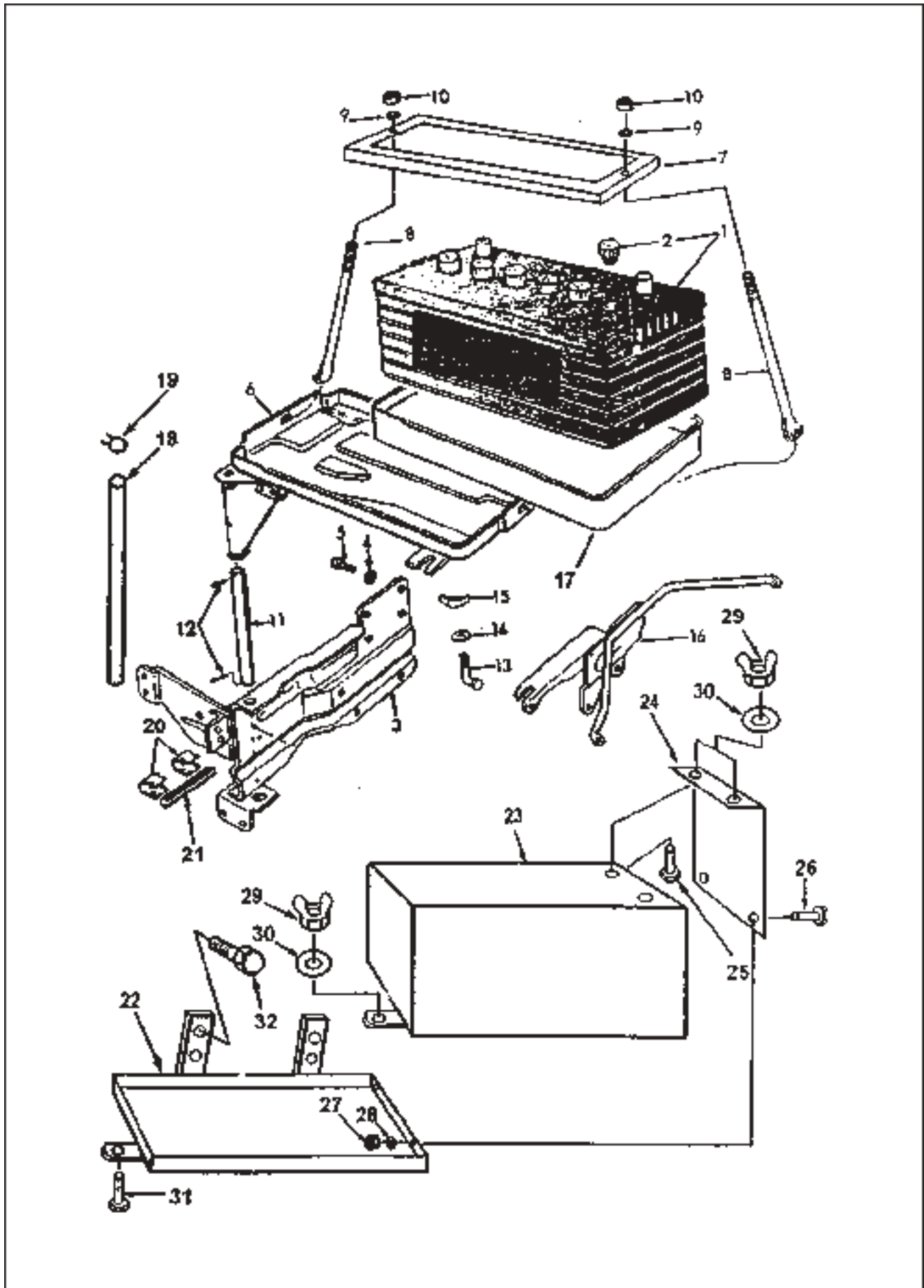

ITEM No.	PART NO.	DESCRIPTION	QTY	REMARKS
21	D10026290	PAD BATTERY	3	
22	D10047270	TRAY BATTERY SUPPORT	1	
23	D10047280	CVR ASSY BATTERY	1	
24	D10047290	PLATE ASSY BATTERY	1	
25	D81000140	BOLT 5/16"-18x0.88" HEX HEAD	2	
26	D81000390	BOLT 1/4"-28x0.62" HEX HEAD	2	
27	D81000400	NUT 1/4"-28 HEX	2	
28	D85000030	WASHER 1/4" FLAT	2	
29	D10018710	NUT 5/16"-18 WING	3	
30	D85000070	WASHER 5/16" FLAT	3	
31	D81000330	BOLT 5/16"-18x1.00" HEX HEAD	1	
32	D81500560	BOLT M12x1.75x30-6G HEX HEAD	2	
33	D10047720	CABLE ASSY BATTERY TO STARTER SOLENOID	1	
34	D10017420	STRAP BATTERY CABLE	6	

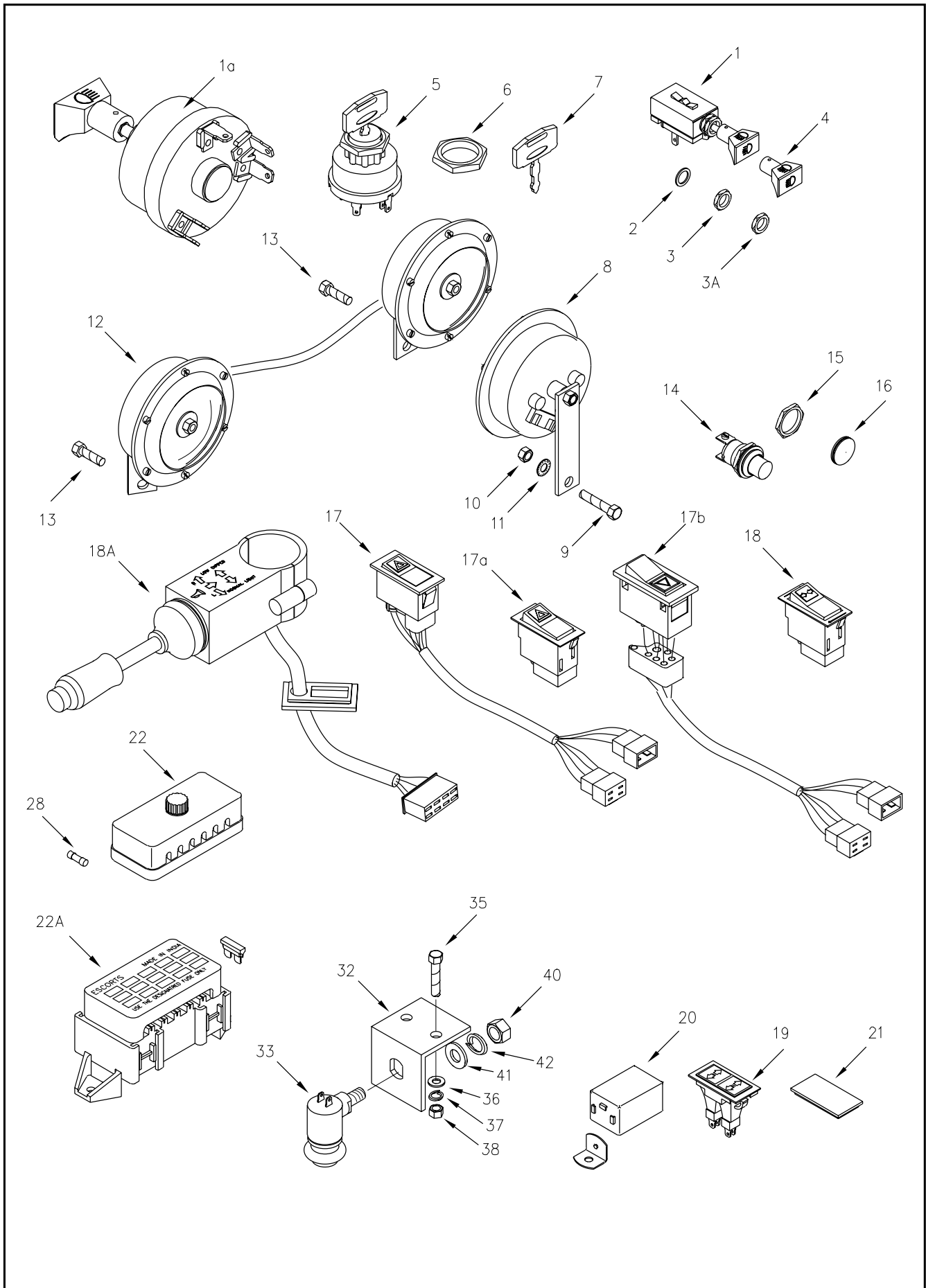

ITEM No.	PART NO.	DESCRIPTION	QTY	REMARKS
1	D10019310	SWITCH ASSY LIGHTING	1	
2	92NH11N654A	WASHER	1	
3	92NH11662A	NUT - LIGHTING SWITCH	1	
4	D10113120	KNOB LIGHT SWITCH	1	
5	D10048140	SWITCH ASSY HEATER AND STARTER	1	
6	C5NN11N496A	NUT - STARTER SWITCH	1	
7	D10071110	KEY FOR IGNITION SWITCH	1	
8	D10028020	HORN AND BRACKET ASSY	1	
9	D81500110	BOLT M8x1.25x20-8.8 HEX HEAD	1	
9a	D83000060	NUT 5/16"-18 HEX	1	
9b	D86000110	WASHER 5/16" LOCK EXTERNAL TOOTH	1	
10	D10016460	SWITCH ASSY HORN BLOWING	1	
12	D10026990	GROMMET ROUND FLANGE	1	
13	D10026490	SWITCH ASSY EMERGENCY WARNING	1	
15	D10098700	SWITCH ASSY WORK LAMP	1	
16	D10026570	FLASHER ASSY INDICATOR	1	
18	D10026970	BOX ASSY FUSE	1	
20	D82000030	SCREW #10-24x0.62" PAN HEAD	2	
21	D83000130	NUT #10-24 HEX	2	
22	D86000080	WASHER #10 SPRING LOCK	2	
23	D10042260	BRACKET BRK SWITCH MNTG	1	
24	D10016930	SWITCH ASSY STOP LAMP	1	
25	D81500320	BOLT M8x1.25x20 CARRIAGE	2	
26	D85000040	WASHER 5/16" FLAT	2	
27	D86500150	WASHER M8 SPRING LOCK	2	
28	D83500230	NUT M8x1.25-5 HEX	2	
29	D83000020	NUT 3/8"-16 HEX	1	
30	D85000090	WASHER 7/16" FLAT	1	
31	D86000010	WASHER 3/8" SPRING LOCK	1	
32	D10026380	SOCKET ASSY TRAILER ELECTRICAL	1	
33	D82000020	SCREW #10-24x0.44" HEX HEAD	3	
34	D83000130	NUT #10-24 HEX	3	
35	D86000140	WASHER #10 LOCK INTERNAL TOOTH	3	
36	D10026980	CVR FUSE BOX	1	
37	D10082740	CVR SWITCH ASSY	2	

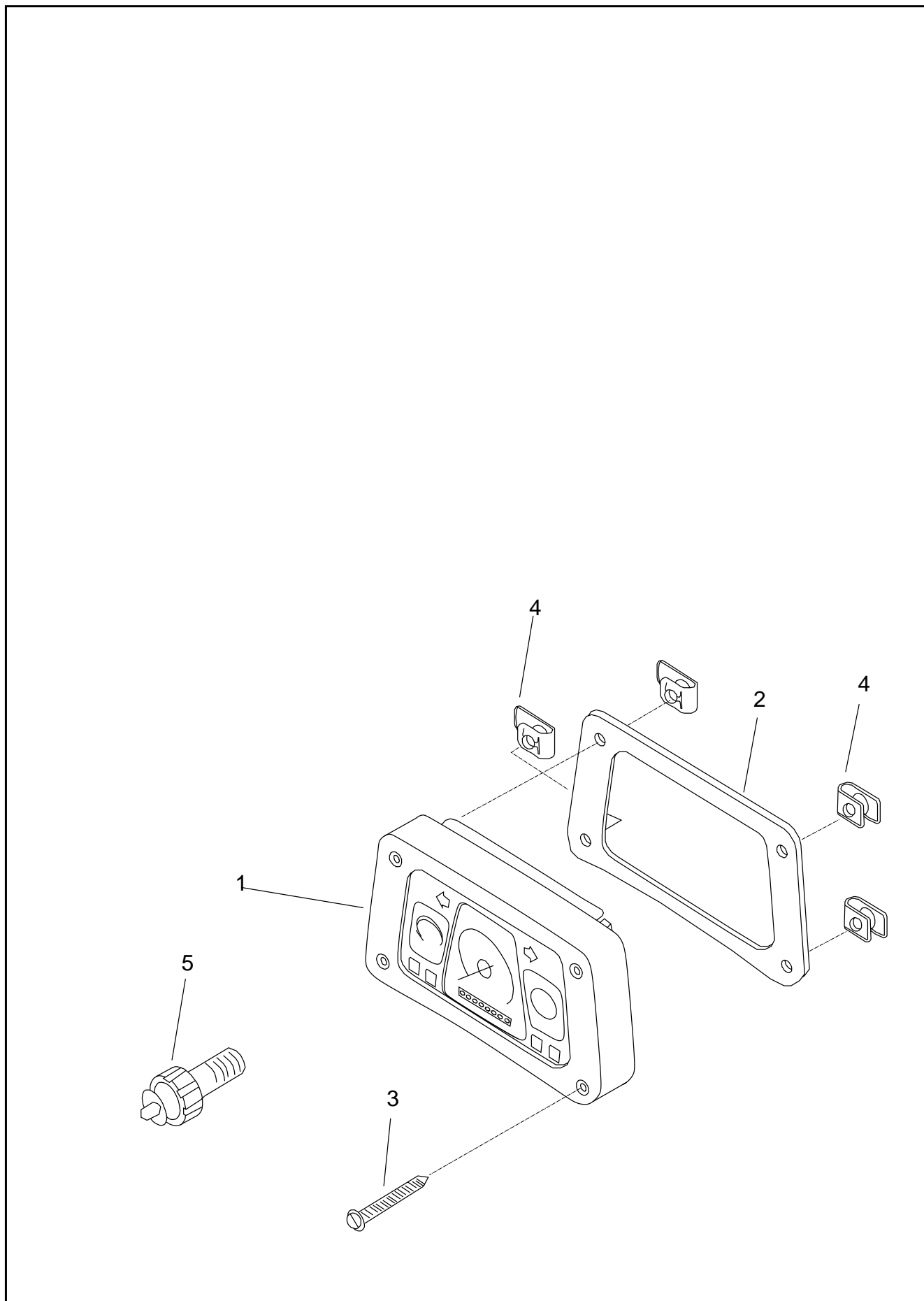

ITEM No.	PART NO.	DESCRIPTION	QTY	REMARKS
1	D10047310	CLUSTER ASSY INSTRUMENT-FT80	1	
2	D10026480	GASKET INSTRUMENT CLUSTER	1	
3	D10016830	SCREW TAPPING #10-16x1.25" CROSS RECESSED PAN HEAD	4	
4	D10016820	NUT INSTRUMENT CLUSTER RETAINING	4	
7	D10021980	GASKET FUEL TANK SENDER	1	
8	D10026010	CLIP FUEL TANK SENSOR WIRE	1	
9	D10026030	SCREW #10-32x0.625" HEX HEAD	5	
13	D81500110	BOLT M8x1.25x20-8.8 HEX HEAD	1	
20	D10017790	LAMP ASSY WARNING INDICATOR	1	
21	D10017840	LAMP ASSY HIGH BEAM AND TURN INDICATOR WARNING	1	

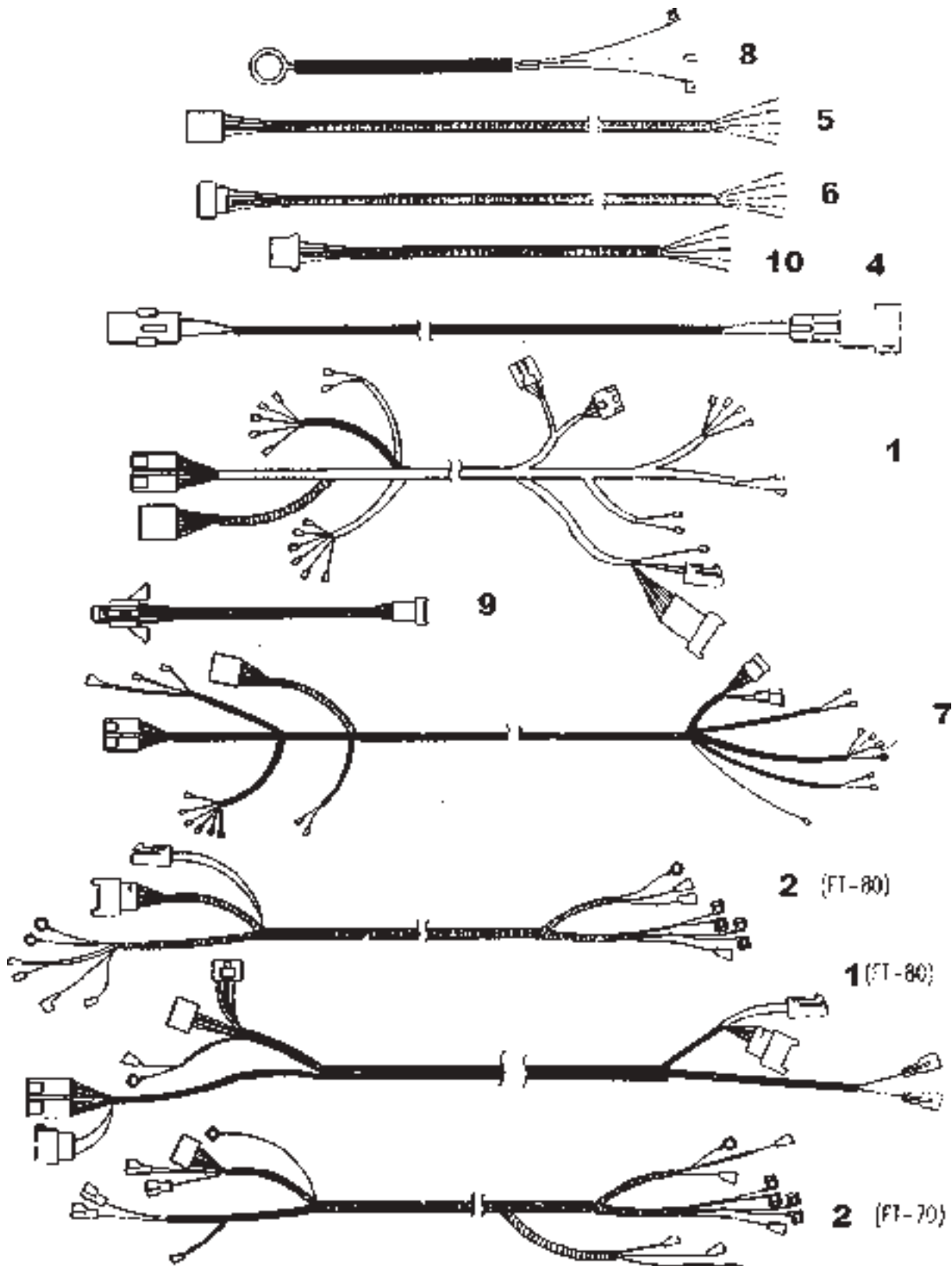

ITEM No.	PART NO.	DESCRIPTION	QTY	REMARKS
1	D10135300	HARNESS INSTRUMENT PANEL (FT80US TIER II)	1	
2	D10117580	HARNESS ASSY MAIN FT80US (TIERII)	1	
3	D10043910	HARNESS TAIL	1	
4	D10044080	HARNESS ASSY WORK LAMP	1	
5	D10026630	HARNESS ROPS LAMP LH	1	
6	D10026620	HARNESS ROPS LAMP RH	1	
8	D10026640	HARNESS WIRING EARTH	1	
9	D10026970	BOX ASSY FUSE	1	
10	D10026370	HARNESS ASSY TRAILER SOCKET	1	
11	D10004160	CLIP WIRING HARNESS RH	1	
12	D10018230	CLIP HARNESS	2	
13	D10117590	HARNESS SWITCHES PANEL FT80US (TIER II)	1	
14	D10019390	CLIP WIRE CONDUIT	1	
16	D10017430	CLIP WIRE CONDUIT	2	
18	D10018400	CLIP BATTERY CABLE	2	

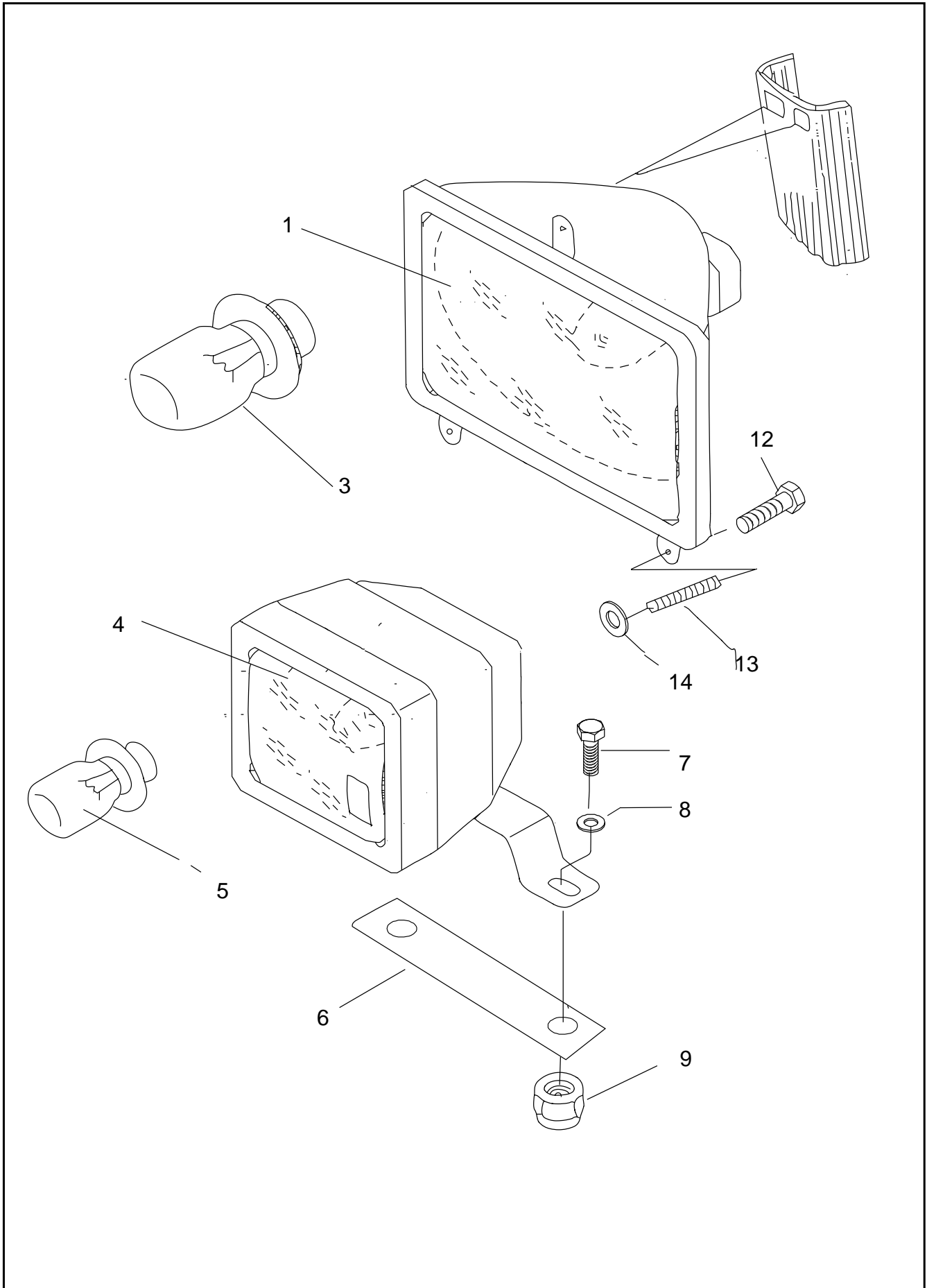

ITEM No.	PART NO.	DESCRIPTION	QTY	REMARKS
3	D10105050	BULB HEADLAMP (12VOLTS)	2	
4	D10026390	LAMP ASSY WORK	1	
5	D10105060	BULB PLOUGH LAMP	1	
6	D10017520	PLATE PLOUGH LAMP	1	
7	D10018380	BOLT 3/8"-24x0.87" DRIVER SEAT HINGE TO SPRING	2	
8	D85000010	WASHER 3/8" FLAT	2	
9	D10016890	NUT 3/8"-24 HEX	2	
10	D10026980	CVR FUSE BOX	1	NI,
11	D10026670	BEADING RADIATOR GRILL	1	NI,
12	2513011AA	SCREW	6	
13	2513012AA	SPRING	6	
14	2513013AA	FIBRE WASHER	6	
1/2	D10026910	HEAD LAMP ASSY	2	NI,

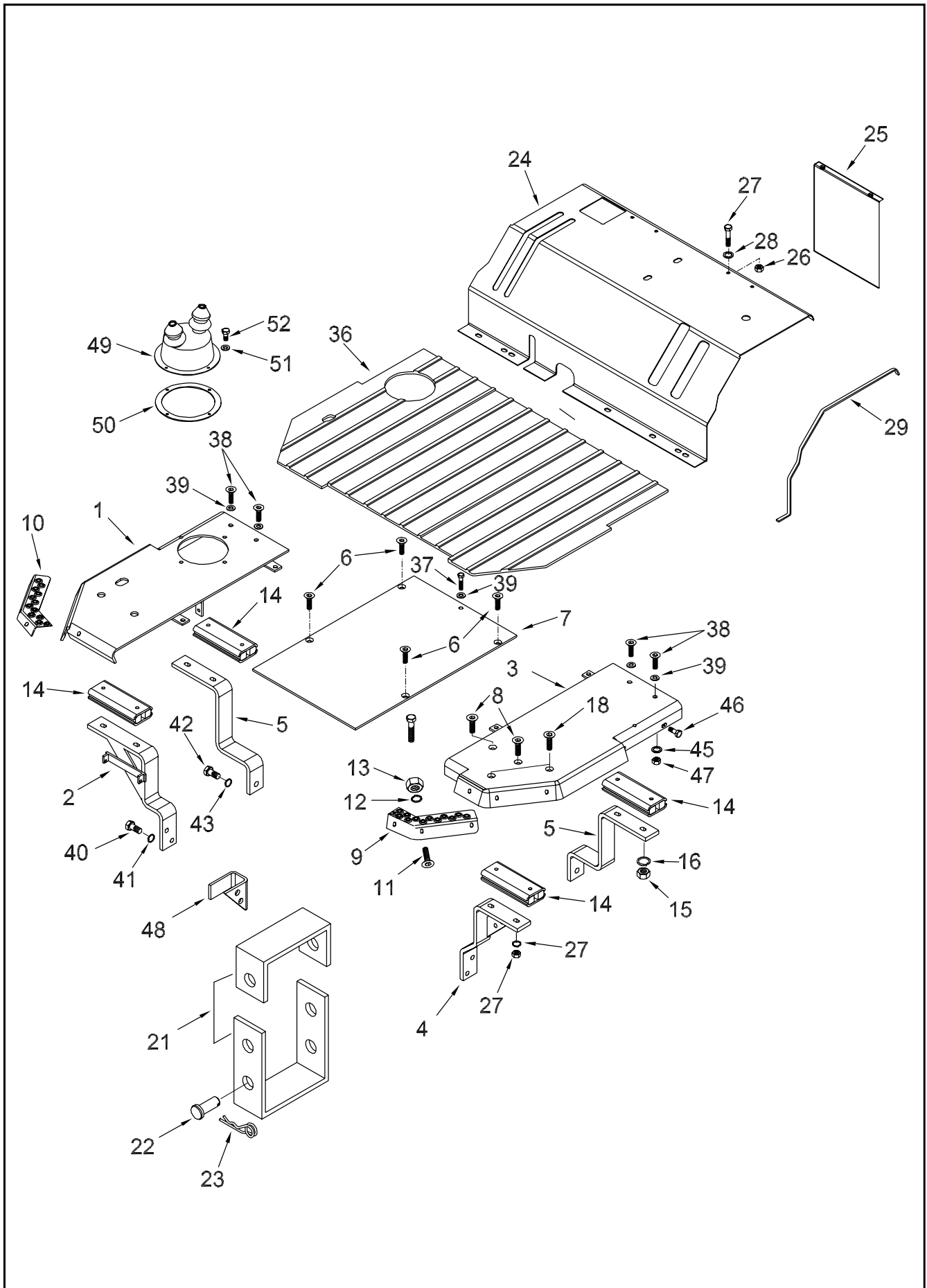

ITEM No.	PART NO.	DESCRIPTION	QTY	REMARKS
1	D10046060	BOARD ASSY RUNNING RH	1	
2	D10047110	BRACKET PLATFORM MNTG FRONT RH	1	
3	D10046070	BOARD ASSY RUNNING LH	1	
4	D10047090	BRACKET PLATFORM MNTG FRONT LH	1	
5	D10039850	BRACKET PLATFORM MNTG REAR	2	
6	D10035370	SCREW M8x1.25x20 COUNTERSUNK HEAD	4	
7	D10046080	PLATE CENTRE PLATFORM	1	
8	D10035370	SCREW M8x1.25x20 COUNTERSUNK HEAD	4	
9	D10046390	STRIP PLATFORM LH	1	
10	D10046400	STRIP PLATFORM RH	1	
11	D82000030	SCREW #10-24x0.62" PAN HEAD	6	
12	D85500140	WASHER M10 FLAT	6	
13	D83000130	NUT #10-24 HEX	6	
14	D10042270	PAD ISOLATOR	4	
15	D83500230	NUT M8x1.25-5 HEX	8	
16	D85500130	WASHER M8 FLAT	8	
18	D10042170	SCREW M10x1.5x25.0 COUNTERSUNK HEAD	2	
19	D83500210	NUT M10x1.50-5 HEX	2	
20	D86500090	WASHER M10 SPRING LOCK	2	
21	D10118190	STEP PLATFORM	1	
22	D82500090	SCREW M12x1.75x25-6.6 HEX HEAD	3	
23	D85500160	WASHER M12 FLAT	3	
24	D10043920	CONSOLE REAR	1	
25	D10042850	CVR REAR CONSOLE	1	
26	D81000400	NUT 1/4"-28 HEX	2	
27	D81000390	BOLT 1/4"-28x0.62" HEX HEAD	2	
28	D85000030	WASHER 1/4" FLAT	2	
29	D10042380	BEADING CONSOLE SIDE	2	
30	D10042390	BEADING CONSOLE	1	
36	D10045980	FOOT MAT PLATFORM	1	
37	D81500110	BOLT M8x1.25x20-8.8 HEX HEAD	1	
38	D81500330	BOLT M8x1.25x40-6G HEX HEAD	4	
39	D85500130	WASHER M8 FLAT	5	
40a	D81500540	BOLT M12x1.75x40-6G HEX HEAD	2	
40b	D81500560	BOLT M12x1.75x30-6G HEX HEAD	2	NI,
41	D86000010	WASHER 3/8" SPRING LOCK	4	
42	D82500090	SCREW M12x1.75x25-6.6 HEX HEAD	2	
43	D86000060	WASHER 1/2" SPRING LOCK	2	
45	D85500130	WASHER M8 FLAT	8	
46	D81000390	BOLT 1/4"-28x0.62" HEX HEAD	6	
47	D83500230	NUT M8x1.25-5 HEX	6	
48	D10017420	STRAP BATTERY CABLE	1	
49	D10042400	BOOT TRANSMISSION LEVER	1	
50	D10042860	RING BOOT TRANSMISSION LEVER	1	
51	D85500110	WASHER M6 FLAT	4	
52	D81500490	BOLT M6x1.0x20-6G HEX HEAD	4	

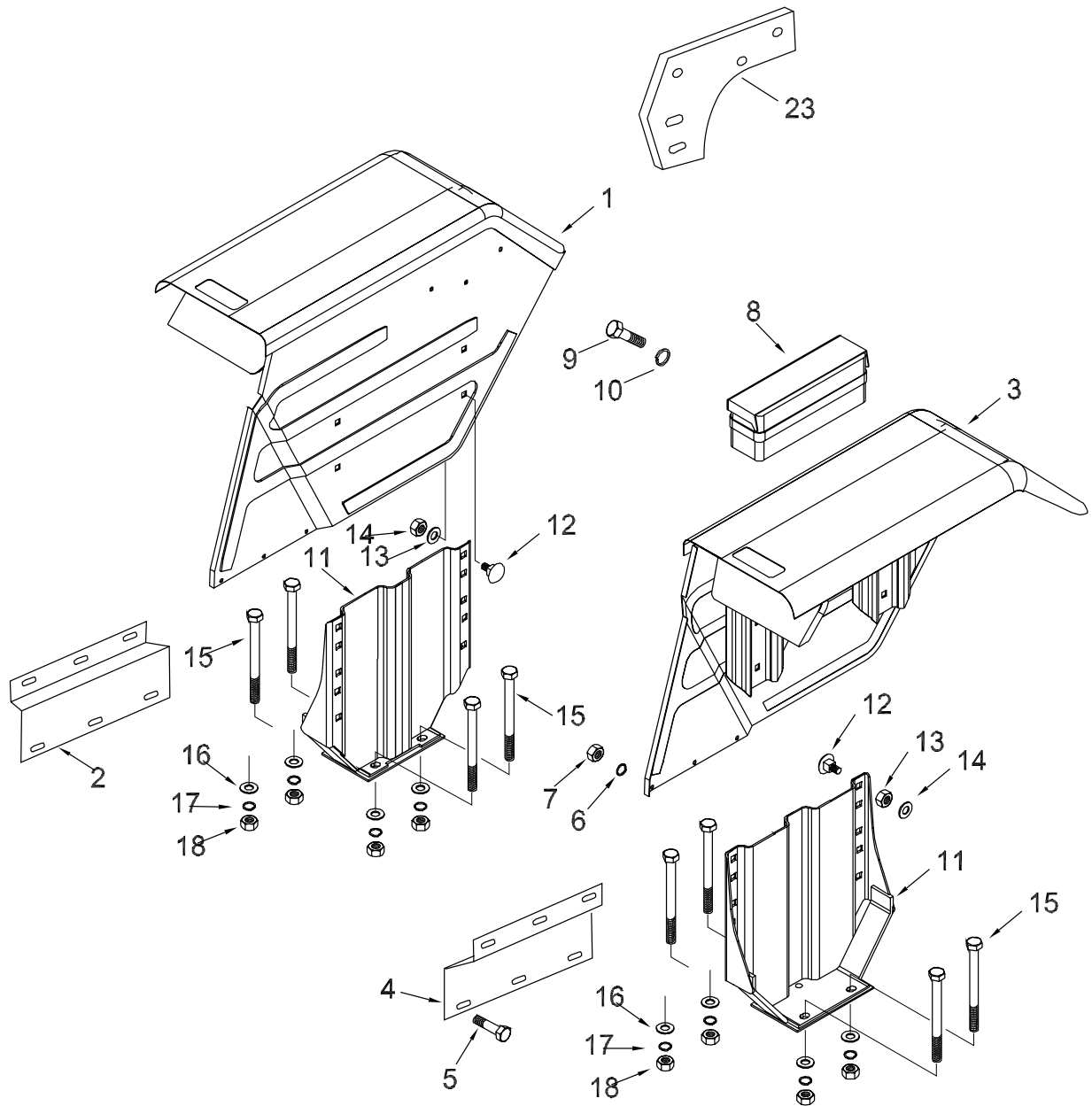

ITEM No.	PART NO.	DESCRIPTION	QTY	REMARKS
1	D10043860	BODY ASSY REAR FENDER RH	1	
2	D10047120	EXTENSION FENDER REAR RH	1	NI,
3	D10043870	BODY ASSY REAR FENDER LH	1	
4	D10047130	EXTENSION FENDER REAR LH	1	NI,
5	D81000390	BOLT 1/4"-28x0.62" HEX HEAD	6	
6	D85000030	WASHER 1/4" FLAT	6	
7	D81000400	NUT 1/4"-28 HEX	6	
9	D81000390	BOLT 1/4"-28x0.62" HEX HEAD	3	
10	D86000110	WASHER 5/16" LOCK EXTERNAL TOOTH	3	
11	D10039810	SUPPORT REAR FENDER	2	NSS-1
12	D81000930	BOLT 1/2"-13x1.25" CARRIAGE	8	
13	D10003580	WASHER 1/2" FLAT	8	
14	D83000050	NUT 1/2"-13 HEX	8	
15	D81000920	BOLT 5/8"-18x8.00" HEX HEAD	8	
16	D10058510	WASHER 5/8" FLAT	8	
17	D86000120	WASHER 5/8" SPRING LOCK	8	
18	D83000160	NUT 5/8"-18 HEX	8	
21	D86000040	WASHER 5/16" SPRING LOCK	2	
22	D81000330	BOLT 5/16"-18x1.00" HEX HEAD	2	
23	D10044270	BRACKET TOOL BOX MNTG	1	NI,
24	D10044290	PAD ROPS	4	NI,

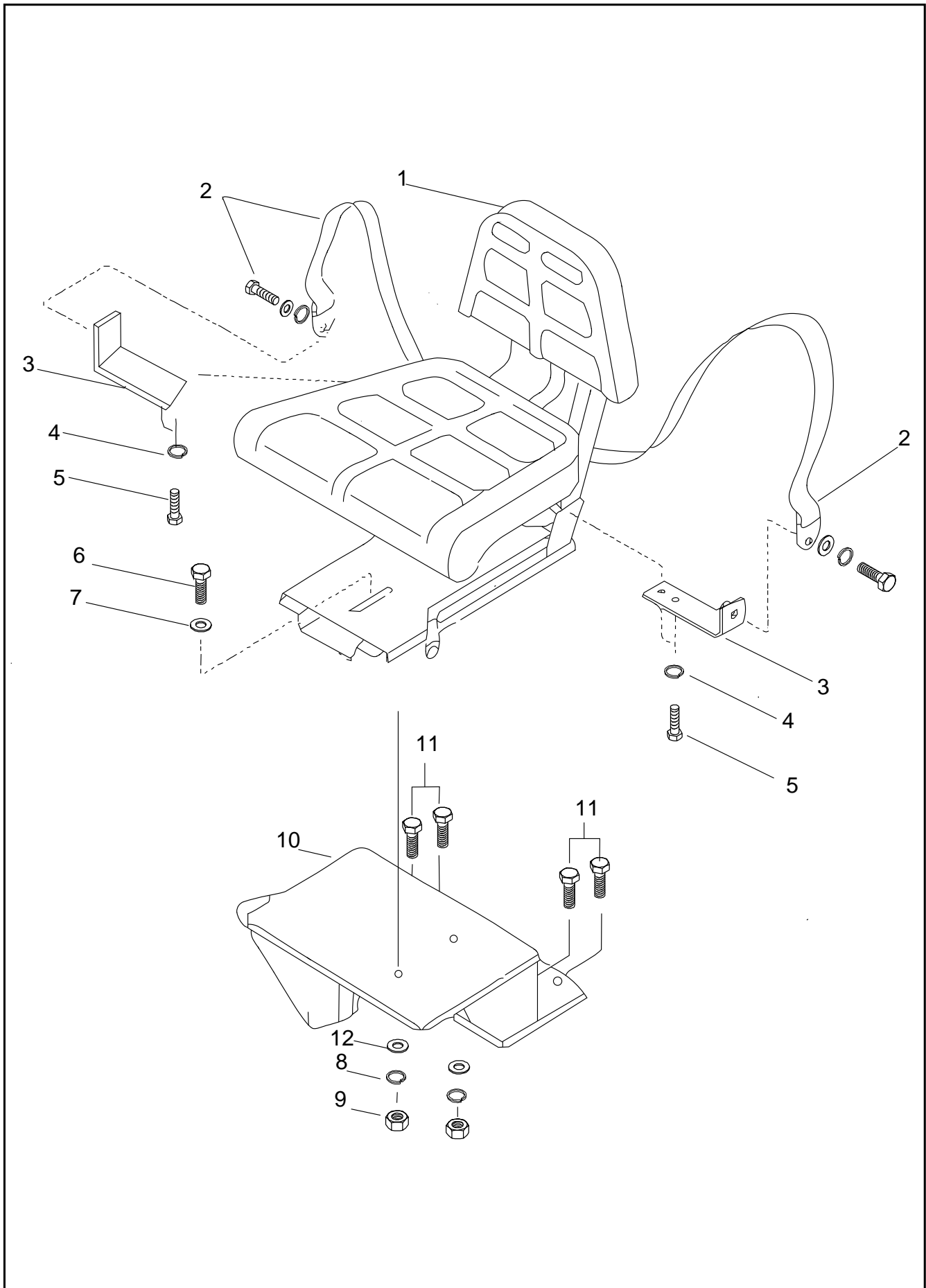

ITEM No.	PART NO.	DESCRIPTION	QTY	REMARKS
1	D10026430	SEAT ASSY DRIVER	1	
2	D10026440	BELT ASSY DRIVER SEAT	1	
3	-	BRACKET ASSY	2	
4	-	SPRING WASHER	4	
5	-	BOLT	4	
6	D81000090	BOLT 7/16"-14x1.25" HEX HEAD	2	
7	D85000090	WASHER 7/16" FLAT	2	
8	D85000040	WASHER 5/16" FLAT	2	
9	D83000040	NUT 7/16"-14HEX	2	
10	D10047300	SUPPORT SEAT MNTG FT-80US	1	
11	D81500580	BOLT M14x2.00x25-6G HEX HEAD LOCK	4	

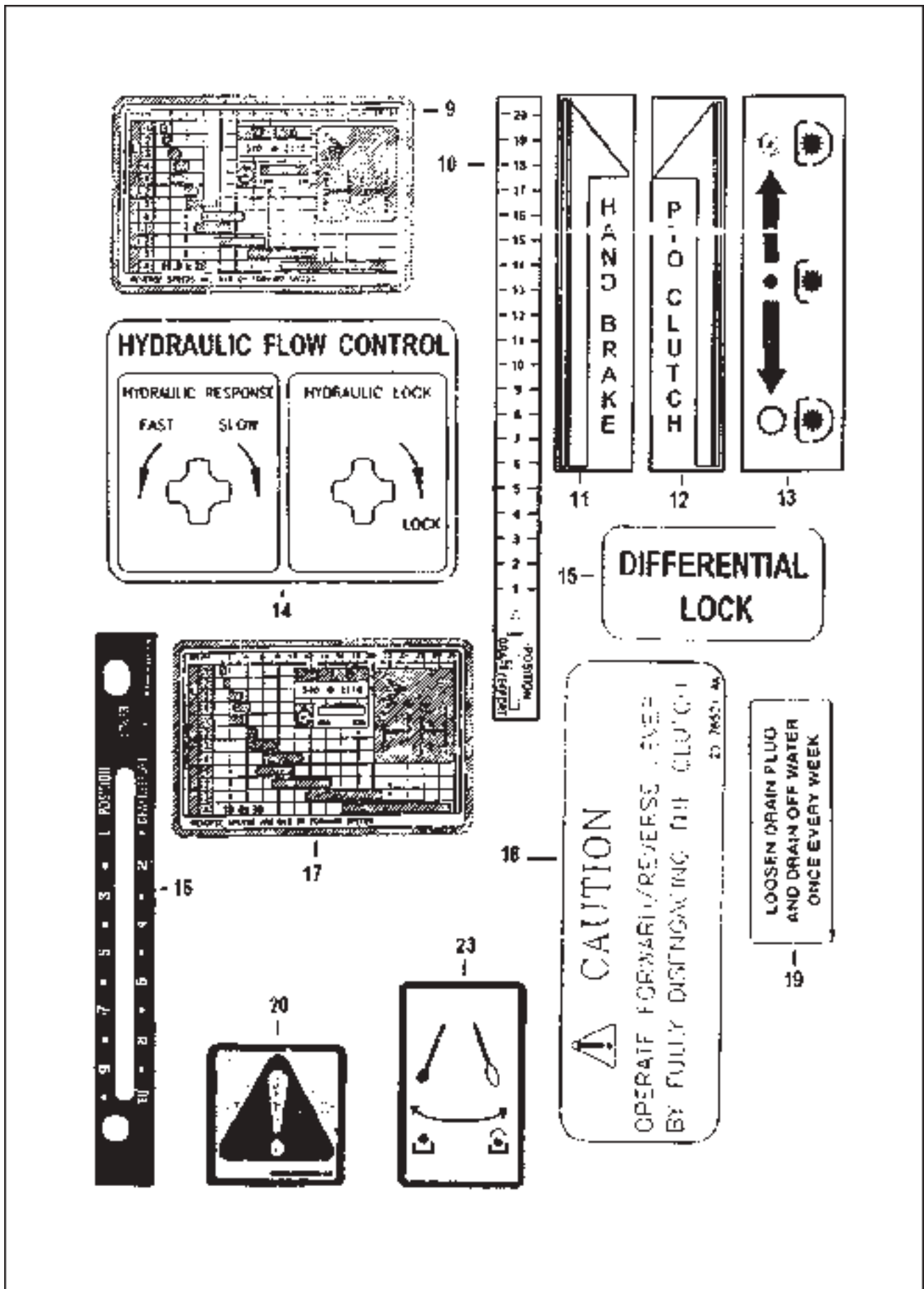

ITEM No.	PART NO.	DESCRIPTION	QTY	REMARKS
1	D10116510	DECAL MODEL IDENTIFICATION HOOD FRONT (FT675)	1	
3	D10046330	DECAL MODEL IDENTIFICATION CENTRE RH	1	
4	D10046320	DECAL MODEL IDENTIFICATION CENTRE LH	1	
7	D10019120	DECAL MODEL IDENTIFICATION REAR LH	1	
8	D10019130	DECAL MODEL IDENTIFICATION REAR RH	1	
9	D10046190	DECAL TRANSMISSION SHIFT PATTERN 18.4"x30"	1	
17	D10017890	DECAL OPERATING INSTRUCTION	1	
18	D10018620	DECAL BATTERY WARNING	1	
19	D10017640	DECAL FILTER CLEANER	1	
20	D10018580	DECAL VEHICLE WARNING	1	
21	D10019110	DECAL TRACTOR MAINTENANCE SERVICE	1	
22	D10019210	DECAL TRACTOR SAFETY INSTRUCTIONS	1	
23	D10019220	DECAL PTO CONTROL	1	
25	D10042410	GR SHIFT PATTERN FORWARD REVERSE	1	
26	D10042430	GR SHIFT PATTERN MAIN	1	
27	D10042420	GR SHIFT PATTERN RANGE	1	
28	D10043940	DECAL PTO GUARD	1	
29	D10026770	DECAL STARTING WARNING	1	
30	D10026780	DECAL TORQUE INSTRUCTION	1	
31	D10026790	DECAL TRACTOR WARNING INSTRUCTIONS	1	
32	D10026800	DECAL SEAT BELT INSTRUCTION	1	
33	D10026810	DECAL CAUTION LONG	1	
34	D10026850	DECAL THERMO START	1	
35	D10026860	PLATE MODEL AND CHASSIS IDENTIFICATION	1	
38	D10108040	DECAL CAUTION ALTERNATOR	1	
39	D10077680	TOOL KIT W/O KEYS	1	KIT
40	D10047350	DECAL RADIATOR FT80	1	
41	D10042310	DECAL FORWARD REVERSE WARNING	1	
42	D10042350	DECAL HYD PUMP AND LIFT QUADRANT	1	

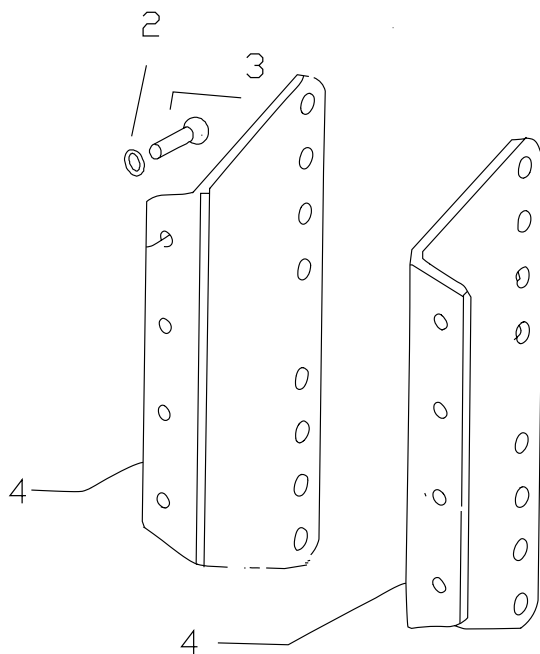

ITEM No.	PART NO.	DESCRIPTION	QTY	REMARKS
2	D86500120	WASHER M16 SPRING LOCK	8	
3	D10042760	BOLT M16x2.00x35	8	
4	D10039390	BRACKET TOW HOOK MNTG	2	
6	D10027320	PIN SAFETY SPLIT	2	
7	D10081260	PIN AND RING ASSY	2	

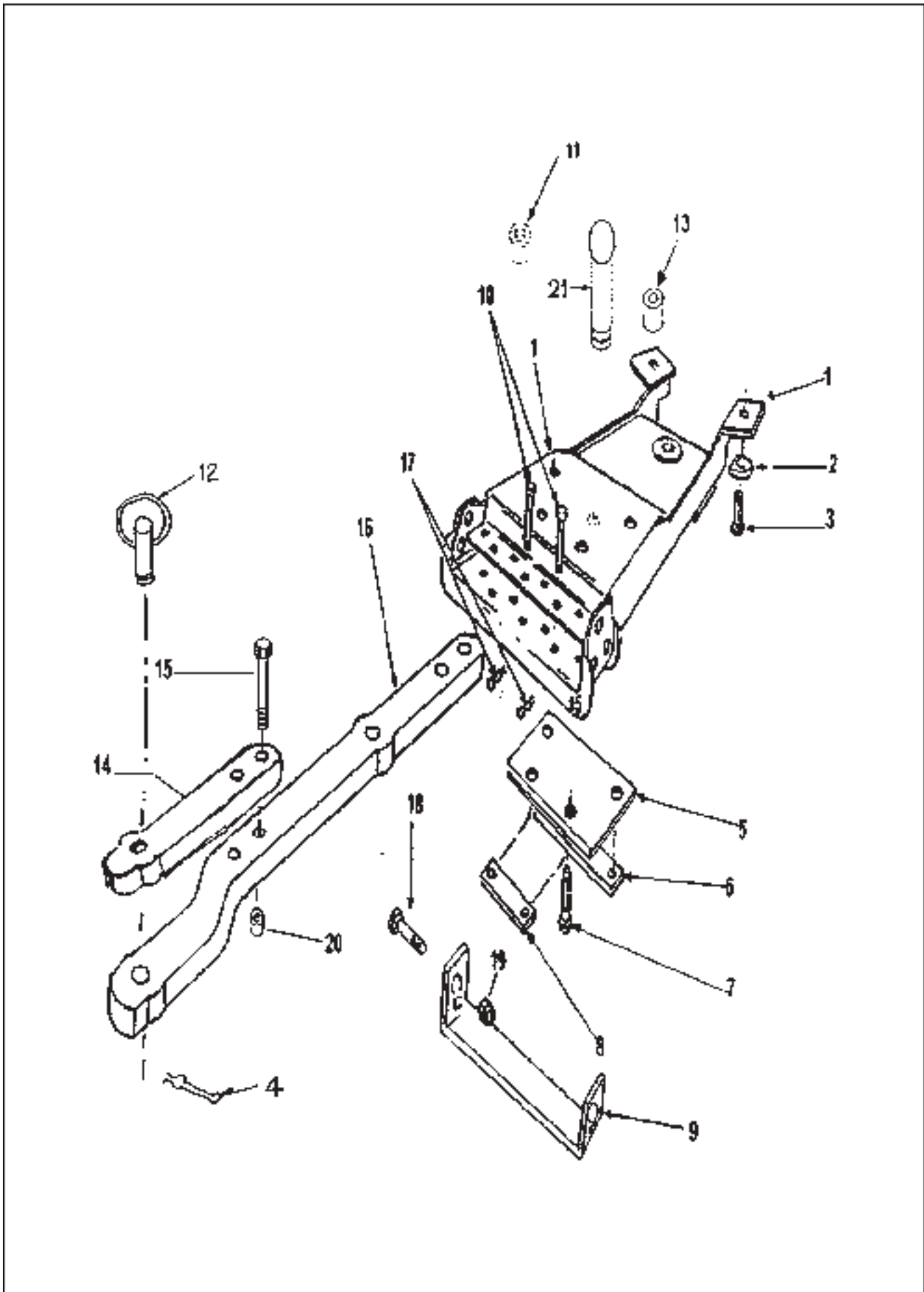

ITEM No.	PART NO.	DESCRIPTION	QTY	REMARKS
1	D10106750	HANGER ASSY DRAWBAR-FT70/80 Export	1	
2	D86000120	WASHER 5/8" SPRING LOCK	2	
3	D81000960	BOLT 5/8"-18x2.25" HEX HEAD	2	
4	D10027270	SPRING DRAWBAR PIN	1	
5	D10027220	PLATE DRAWBAR HANGER	1	
6	D10027300	STRAP DRAWBAR HANGER REINFORCEMENT LOCK	1	
7	D81000760	BOLT 5/8"-11x2.00" HEX HEAD	4	
8	D10027290	STRAP DRAWBAR HANGER REINFORCEMENT LOCK	1	
9	D10043970	BRACKET HANGER SUPPORT	1	
10	D10087780	PIN DRAWBAR ADJ-FT70/80 EXPORT	2	
11	D83000090	NUT 5/8"-11 HEX	4	
12	D10027260	PIN DRAWBAR	1	
13	D10043960	SPACER	2	
14	D10087770	STRAP DRAWBAR-FT70/80	1	
15	D81000450	BOLT 7/16"-14x0.75 HEX HEAD	2	
16	D10087750	DRAWBAR SWINGING-FT70/80	1	
17	D10026210	CLIP DRAWBAR	2	
18	D10043980	BOLT HANGER SUPPORT	4	
19	D83500270	NUT M16x2.00-5 HEX	4	
20	D83000040	NUT 7/16"-14HEX	2	
21	D10027260	PIN DRAWBAR	2	
22	D10047700	PIN DRAWBAR	1	

FARMTRAC



FARMTRAC



NUMERICAL INDEX

PART NO	SHEET	ITEM	PART NO	SHEET	ITEM	PART NO	SHEET	ITEM	PART NO	SHEET	ITEM
D93600410	102028-1	26	D10046070	102047-11	3	D81500560	102047-11	40b			
D93600420	102028-1	27	D10046080	102047-11	7	D81500560	103107A-1	7f			
D93600430	102028-1	25	D10046190	102050A-11	9	D81500580	102049-4	11			
D10003580	102048A-6	13	D10046260	103107A-1	52a	D81500580	103107A-1	55			
D10003580	103107A-1	47	D10046320	102050A-11	4	D81500740	103107A-1	44			
D10012140	103107A-1	10a	D10046330	102050A-11	3	D82000030	102047-11	11			
D10012190	103107A-1	7g	D10046390	102047-11	9	D82500090	102047-11	22			
D10012210	103107A-1	7h	D10046400	102047-11	10	D82500090	102047-11	42			
D10013170	103107A-1	37	D10046680	103107A-1	43	D82500090	103107A-1	10b			
D10013260	103107A-1	9a	D10046760	103107A-1	42	D83000040	102049-4	9			
D10016560	103107A-1	39	D10046780	103107A-1	52	D83000040	102054A-3	20			
D10016780	103107A-1	10c	D10046790	103107A-1	28	D83000050	102048A-6	14			
D10017420	102047-11	48	D10046800	103107A-1	66	D83000050	103107A-1	49			
D10017460	103107A-1	31	D10046810	103107A-1	67	D83000090	102054A-3	11			
D10017640	102050A-11	19	D10046870	103107A-1	7a	D83000130	102047-11	13			
D10017890	102050A-11	17	D10046870	103107A-1	20	D83000160	102048A-6	18			
D10018500	103107A-1	40	D10046990	103107A-1	23	D83500210	102047-11	19			
D10018580	102050A-11	20	D10047000	103107A-1	32	D83500230	102047-11	15			
D10018620	102050A-11	18	D10047010	103107A-1	25	D83500230	102047-11	47			
D10019110	102050A-11	21	D10047020	103107A-1	24	D83500270	102054A-3	19			
D10019120	102050A-11	7	D10047070	103107A-1	69	D85000030	102047-11	28			
D10019130	102050A-11	8	D10047080	103107A-1	52b	D85000030	102048A-6	6			
D10019210	102050A-11	22	D10047090	102047-11	4	D85000040	102049-4	8			
D10019220	102050A-11	23	D10047110	102047-11	2	D85000090	102049-4	7			
D10021080	103107A-1	64	D10047120	102048A-6	2	D85500110	102047-11	51			
D10021080	103107A-1	65	D10047130	102048A-6	4	D85500130	102047-11	16			
D10021130	103107A-1	29	D10047250	103107A-1	1	D85500130	102047-11	39			
D10021160	103107A-1	22	D10047300	102049-4	10	D85500130	102047-11	45			
D10021270	103107A-1	27	D10047350	102050A-11	40	D85500140	102047-11	12			
D10021280	103107A-1	26	D10047700	102054A-3	22	D85500160	102047-11	23			
D10021630	103107A-1	68	D10058510	102048A-6	16	D86000010	102047-11	41			
D10026210	102054A-3	17	D10077680	102050A-11	39	D86000040	102048A-6	21			
D10026430	102049-4	1	D10081260	102051-2	7	D86000060	102047-11	43			
D10026440	102049-4	2	D10084110	103107A-1	54	D86000060	103107A-1	48			
D10026770	102050A-11	29	D10084120	103107A-1	56	D86000110	102048A-6	10			
D10026780	102050A-11	30	D10087750	102054A-3	16	D86000120	102048A-6	17			
D10026790	102050A-11	31	D10087770	102054A-3	14	D86000120	102054A-3	2			
D10026800	102050A-11	32	D10087780	102054A-3	10	D86500090	102047-11	20			
D10026810	102050A-11	33	D10090900	103107A-1	33	D86500110	103107A-1	45			
D10026850	102050A-11	34	D10092550	103107A-1	30	D86500120	102051-2	2			
D10026860	102050A-11	35	D10092560	103107A-1	30a	D93600020	103107A-1	7e			
D10027220	102054A-3	5	D10098750	103107A-1	41	D93600070	103107A-1	22a			
D10027260	102054A-3	12	D10100140	103107A-1	61	D93600110	103107A-1	15			
D10027260	102054A-3	21	D10106750	102054A-3	1	D93600110	103107A-1	19			
D10027270	102054A-3	4	D10108040	102050A-11	38	D93600140	103107A-1	3			
D10027290	102054A-3	8	D10116510	102050A-11	1	D93600150	103107A-1	2			
D10027300	102054A-3	6	D10118190	102047-11	21						
D10027320	102051-2	6	D10124600	103107A-1	5						
D10034950	103107A-1	8a	D10124600	103107A-1	62						
D10035370	102047-11	6	D10131710	103107A-1	6						
D10035370	102047-11	8	D10131730	103107A-1	7						
D10039260	103107A-1	51	D10131740	103107A-1	72						
D10039390	102051-2	4	D10131750	103107A-1	4						
D10039690	103107A-1	38	D10131760	103107A-1	70						
D10039720	103107A-1	60	D10131770	103107A-1	17						
D10039810	102048A-6	11	D10131770	103107A-1	63						
D10039850	102047-11	5	D10131790	103107A-1	74						
D10042170	102047-11	18	D10131810	103107A-1	16						
D10042270	102047-11	14	D10131820	103107A-1	73						
D10042310	102050A-11	41	D10131840	103107A-1	21						
D10042350	102050A-11	42	D10131850	103107A-1	21a						
D10042380	102047-11	29	D10135290	103107A-1	75						
D10042390	102047-11	30	D10139860	103107A-1	9b						
D10042400	102047-11	49	D81000090	102049-4	6						
D10042410	102050A-11	25	D81000330	102048A-6	22						
D10042420	102050A-11	27	D81000350	103107A-1	46						
D10042430	102050A-11	26	D81000390	102047-11	27						
D10042570	103107A-1	71	D81000390	102047-11	46						
D10042690	103107A-1	53	D81000390	102048A-6	5						
D10042760	102051-2	3	D81000390	102048A-6	9						
D10042850	102047-11	25	D81000400	102047-11	26						
D10042860	102047-11	50	D81000400	102048A-6	7						
D10043860	102048A-6	1	D81000450	102054A-3	15						
D10043870	102048A-6	3	D81000760	102054A-3	7						
D10043920	102047-11	24	D81000920	102048A-6	15						
D10043940	102050A-11	28	D81000930	102048A-6	12						
D10043960	102054A-3	13	D81000960	102054A-3	3						
D10043970	102054A-3	9	D81500110	102047-11	37						
D10043980	102054A-3	18	D81500330	102047-11	38						
D10044230	103107A-1	18	D81500340	103107A-1	52c						
D10044270	102048A-6	23	D81500490	102047-11	52						
D10044290	102048A-6	24	D81500490	103107A-1	5a						
D10045980	102047-11	36	D81500540	102047-11	40a						
D10046060	102047-11	1	D81500540	103107A-1	57						

NUMERICAL INDEX

PART NO	SHEET	ITEM	PART NO	SHEET	ITEM	PART NO	SHEET	ITEM	PART NO	SHEET	ITEM
---------	-------	------	---------	-------	------	---------	-------	------	---------	-------	------

NUMERICAL INDEX

PART NO	SHEET	ITEM	PART NO	SHEET	ITEM	PART NO	SHEET	ITEM	PART NO	SHEET	ITEM
---------	-------	------	---------	-------	------	---------	-------	------	---------	-------	------



ESCORTS

ESCORTS LIMITED

**Agri Machinery Marketing Division
(Parts & Service)**

**Plot No. : 115, Sector-24, Faridabad-121 005, India
Phone 2440084-88, Fax : 2442833
e-mail : SPD_query@Escorts.co.in**