

AGCO ALLIS

OPERATOR'S MANUAL

1700 SERIES

16 HP Gear

Mfg. No. 1692444

Mfg. No. 1692567

16 HP Hydro

Mfg. No. 1692446

Mfg. No. 1692574

Mfg. No. 1692633

Mfg. No. 1692837

18 HP Hydro

Mfg. No. 1692448

Mfg. No. 1692578

Mfg. No. 1692841

44" Mower Deck

Mfg. No. 1692035

Mfg. No. 1692687

50" Mower Deck

Mfg. No. 1692038

Mfg. No. 1692689

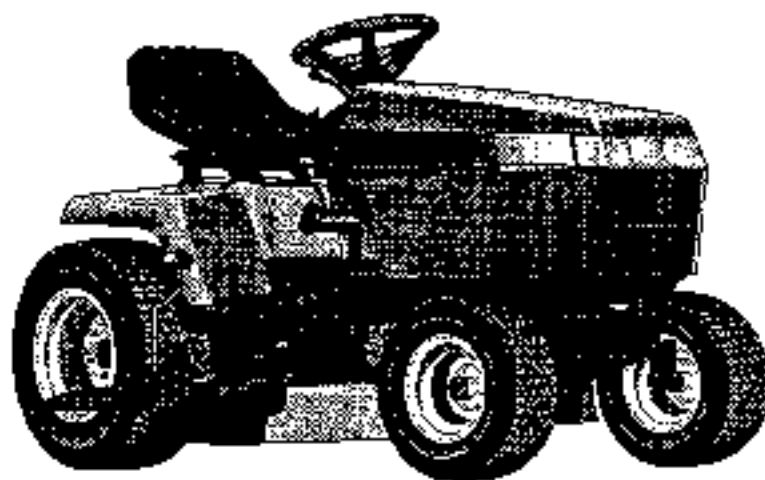

Table Of Contents

TRACTOR & MOWER IDENTIFICATION	2	STORAGE	21
SAFETY RULES	3	Temporary Storage.....	21
SAFETY DECALS	5	Long Term Storage.....	21
FEATURES & CONTROLS	6	Starting After Storage.....	22
Tractor Controls.....	6	TROUBLESHOOTING & REPAIR	23
Tractor & Mower Features.....	7	General.....	23
Engine Compartment.....	8	Troubleshooting The Tractor.....	23
Safety Interlock System.....	8	Troubleshooting The Mower.....	24
OPERATION	9	Checking the Battery.....	24
General.....	9	Charging A Completely	
Mower Installation.....	9	Discharged Battery.....	24
Mower Removal.....	10	Jump Starting with	
Operating The Mower.....	10	Auxiliary (Booster) Battery.....	25
Checks Before Starting.....	11	ADJUSTMENTS	27
Clutch/Brake Pedal - Hydro Models.....	11	Seat Adjustment.....	27
Clutch & Brake Pedals - Gear Models.....	11	Brake Adjustment - Gear Models.....	27
Starting The Engine.....	12	Brake Adjustment - Hydro Models.....	27
Selecting Ground Speed & Engine Speed.....	12	PTO (Electric Clutch) Adjustment.....	27
Stopping the Tractor.....	12	Steering Gear Adjustment.....	28
Pushing the Tractor by Hand.....	14	Steering Wheel Adjustment.....	28
MOWING PATTERN & TIPS	15	Mower Adjustments.....	28
NORMAL CARE	17	Leveling the Mower.....	28
Schedule.....	17	Blade Brake Adjustment.....	29
Raising the Hood.....	17	BELT REPLACEMENT	30
Checking/Adding Gasoline.....	17	Tractor Drive Belt.....	30
Checking Tire Pressure.....	17	Mower Deck-To-PTO Belt.....	31
Checking the Fuel Filter.....	17	Mower Arbor Belt.....	31
Lubrication.....	18	SPECIFICATIONS	33
Lubricating the Tractor.....	18	PARTS & ACCESSORIES	35
Lubricating the Mower.....	19	Common Replacement Parts.....	35
Battery Maintenance.....	19	Maintenance Items.....	35
Checking Battery Fluid.....	19	Optional Accessories.....	36
Cleaning the Battery and Cables.....	19	Technical Literature.....	36
Servicing the Mower Blades.....	19	International Symbols.....	36
Checking Transmission Fluid.....	20		
Changing Transmission Fluid & Filter.....	20		

NOTE: In this manual, "left" and "right" are referred to as seen from the operating position.

WARNING

Engine exhaust from this product contains chemicals known, in certain quantities, to cause cancer, birth defects, or other reproductive harm.

Tractor & Mower Identification

IDENTIFICATION NUMBERS

Record your model number, manufacturer number and engine serial number in the space provided for easy reference. The models and manufacturer numbers covered in this manual are listed on the front cover.

The tractor I.D. tag is located on the left-side, front of the frame, as shown below. The mower deck I.D. tag is also on the left side, on top of the mower deck.

Refer to the engine Owner's Manual for location of engine serial number.

Be sure to fill out and return the Warranty Registration Card supplied with your tractor.

MODEL REFERENCE	
Model Number:	_____
Manufacturer Number:	_____
Engine I.D. Number:	_____
Dealer Name/Date Purchased:	_____

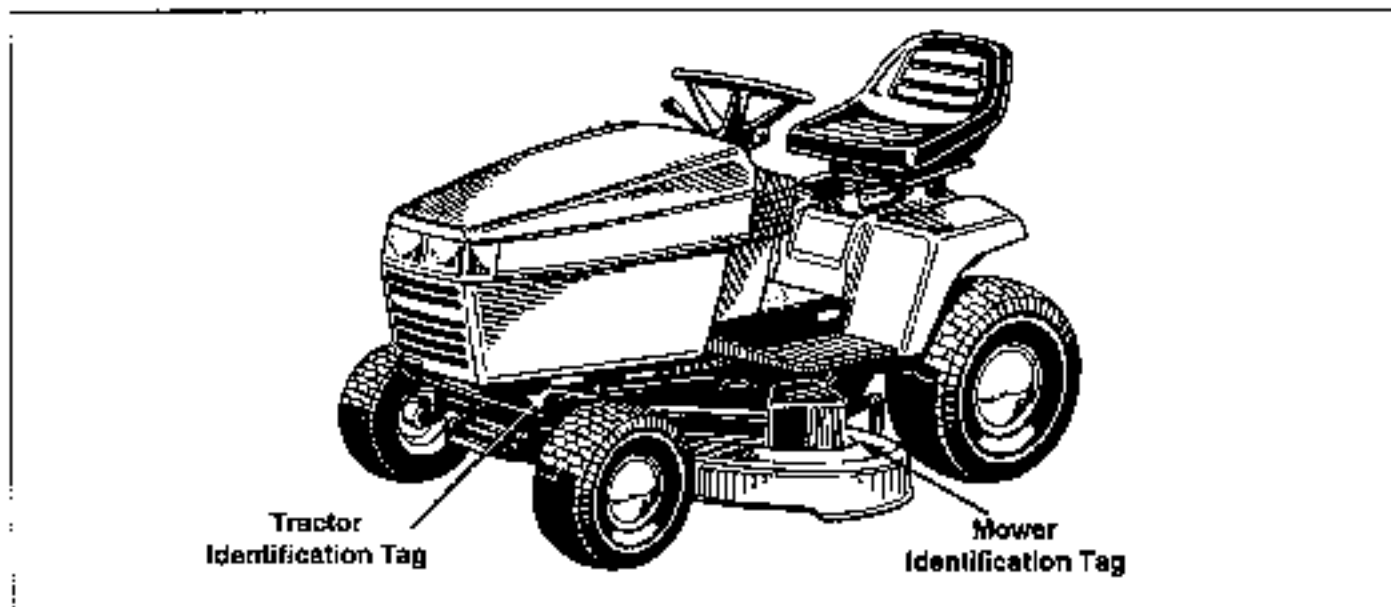



Figure 1. Tractor & Mower Identification Tags



Read these safety rules and follow them closely. Failure to obey these rules could result in loss of control of rider, severe personal injury or death to you, or bystanders, or damage to property or equipment. **This mowing deck is capable of amputating hands and feet and throwing objects.** The triangle  in text signifies important cautions or warnings which must be followed.

GENERAL OPERATION

- Read, understand, and follow all instructions in the manual and on the unit before starting.
- Only allow responsible adults, who are familiar with the instructions, to operate the unit.
- Clear the area of objects such as rocks, toys, wire, etc., which could be picked up and thrown by the blade(s).
- Be sure the area is clear of other people before mowing. Stop unit if anyone enters the area.
- Never carry passengers.
- Do not mow in reverse unless absolutely necessary. Always look down and behind before and while traveling in reverse.
- Be aware of the mower discharge direction and do not point it at anyone. Do not operate the mower without either the entire grass catcher or the deflector in place.
- Slow down before turning.
- Never leave a running unit unattended. Always disengage the PTO, set parking brake, stop engine, and remove keys before dismounting.
- Turn off the PTO switch to disengage the blades when not mowing.
- Stop engine before removing grass catcher or unclogging chute.
- Mow only in daylight or good artificial light.
- Do not operate the unit while under the influence of alcohol or drugs.
- Watch for traffic when operating near or crossing roadways.
- Use extra care when loading or unloading the unit onto a trailer or truck.

SLOPE OPERATION

Slopes are a major factor related to loss-of-control and tip-over accidents, which can result in severe injury or death. All slopes require extra caution. If you cannot back up the slope or if you feel uneasy on it, do not mow it.

WARNING - SLOPE OPERATION

Never operate on slopes greater than 30 percent (16.7°) which is a rise of three feet vertically in 10 feet horizontally. When operating on slopes that are greater than 15 percent (8.5°) but less than 30 percent use front counterweights and rear wheel weights (see your dealer). Select slow ground speed before driving onto slope. In addition to front and rear weights, use extra caution when operating on slopes with rear-mounted grass catcher. Mow UP and DOWN the slope, never across the face, use caution when changing directions and DO NOT START OR STOP ON SLOPE.

Do

- See your authorized dealer for recommendations of wheel weights or counterweights to improve stability.
- Mow up and down slopes, not across.
- Remove obstacles such as rocks, tree limbs, etc.
- Watch for holes, ruts, or bumps. Uneven terrain could overturn the unit. Tall grass can hide obstacles.
- Use slow speed. Choose a low gear so that you will not have to stop or shift while on the slope.
- Use extra care with grass catchers or other attachments. These can change the stability of the unit.
- Keep all movement on the slopes slow and gradual. Do not make sudden changes in speed or direction.

Do Not

- Do not start or stop on a slope. If tires lose traction, disengage the blade(s) and proceed slowly straight down the slope.
- Do not turn on slopes unless necessary, and then, turn slowly and gradually downhill, if possible.
- Do not mow near drop-offs, ditches, or embankments. The mower could suddenly turn over if a wheel is over the edge of a cliff or ditch, or if an edge caves in.
- Do not mow on wet grass. Reduced traction could cause sliding.
- Do not try to stabilize the unit by putting your foot on the ground.
- Do not use grass catcher on steep slopes.

Safety Rules

CHILDREN

Tragic accidents can occur if the operator is not alert to the presence of children. Children are often attracted to the unit and the mowing activity. Never assume that children will remain where you last saw them.

- Keep children out of the mowing area and under the watchful care of another responsible adult.
- Be alert and turn unit off if children enter the area.
- Before and when backing, look behind and down for small children.
- Never carry children. They may fall off and be seriously injured or interfere with safe unit operation.
- Never allow children to operate the unit.
- Use extra care when approaching blind corners, shrubs, trees, or other objects that may obscure vision.

TRANSPORTING AND STORAGE

- Always observe safe refueling and fuel handling practices when refueling the tractor after transportation or storage.
- Always follow the engine manual instructions for storage preparations before storing the tractor for both short and long term periods.
- Always follow the engine manual instructions for proper start-up procedures when returning the unit to service.
- Never store the unit or fuel container inside where there is an open flame or pilot light, such as in a water heater. Allow unit to cool before storing.

SERVICE AND MAINTENANCE

- Use extra care in handling gasoline and other fuels. They are flammable and vapors are explosive.
 - a) Use only an approved container.
 - b) Never remove gas cap or add fuel with the engine

running. Allow engine to cool before refueling. Do not smoke.

- c) Never refuel the unit indoors.
 - Never run a unit inside a closed area.
- Keep nuts and bolts, especially blade attachment bolts, tight and keep equipment in good condition.
- Never tamper with safety devices. Check their proper operation regularly.
- Keep unit free of grass, leaves, or other debris build-up. Clean up oil or fuel spillage.
- Stop and inspect the equipment if you strike an object. Repair, if necessary, before restarting.
- Never make adjustments or repairs with the engine running unless specified otherwise in the engine manufacturer's manual.
- Grass catcher components are subject to wear, damage, and deterioration, which could expose moving parts or allow objects to be thrown. Frequently check components and replace with manufacturer's recommended parts, when necessary.
- Mower blades are sharp and can cut. Wrap the blade(s) or wear gloves, and use extra caution when servicing them.
- Check brake operation frequently. Adjust and service as required.
- Use only factory authorized replacement parts when making repairs.
- Always comply with factory specifications on all settings and adjustments.
- Only authorized service locations should be utilized for major service and repair requirements.
- Never attempt to make major repairs on this unit unless you have been properly trained. Improper service procedures can result in hazardous operation, equipment damage and voiding of manufacturer's warranty.

GENERAL

This unit has been designed and manufactured to provide you with the safety and reliability you would expect from an industry leader in outdoor power equipment manufacturing.

Although reading this manual and the safety instructions it contains will provide you with the necessary basic knowledge to operate this equipment safely and effectively, we have placed several safety labels on the unit to remind you of this important information while you are operating your tractor.

All WARNING, CAUTION and instructional messages on your tractor and mower should be carefully read and obeyed. Personal bodily injury can result when these instructions are not followed. The information is for your safety and it is important! The safety decals shown below are on your tractor and mower.

If any of these decals are lost or damaged, replace them at once. See your local dealer for replacements.

These labels are easily applied and will act as a constant visual reminder to you, and others who may use the equipment, to follow the safety instructions necessary for safe, effective operation.

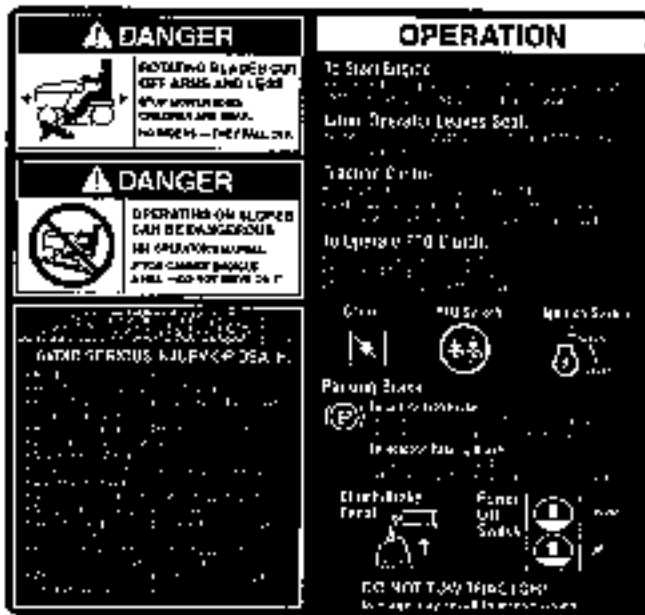

Decal - Operating Information
Part No. 1716529



Decal - Danger
Part No. 1704276



Decal - Danger
Part No. 1704277

Features & Controls

TRACTOR CONTROLS

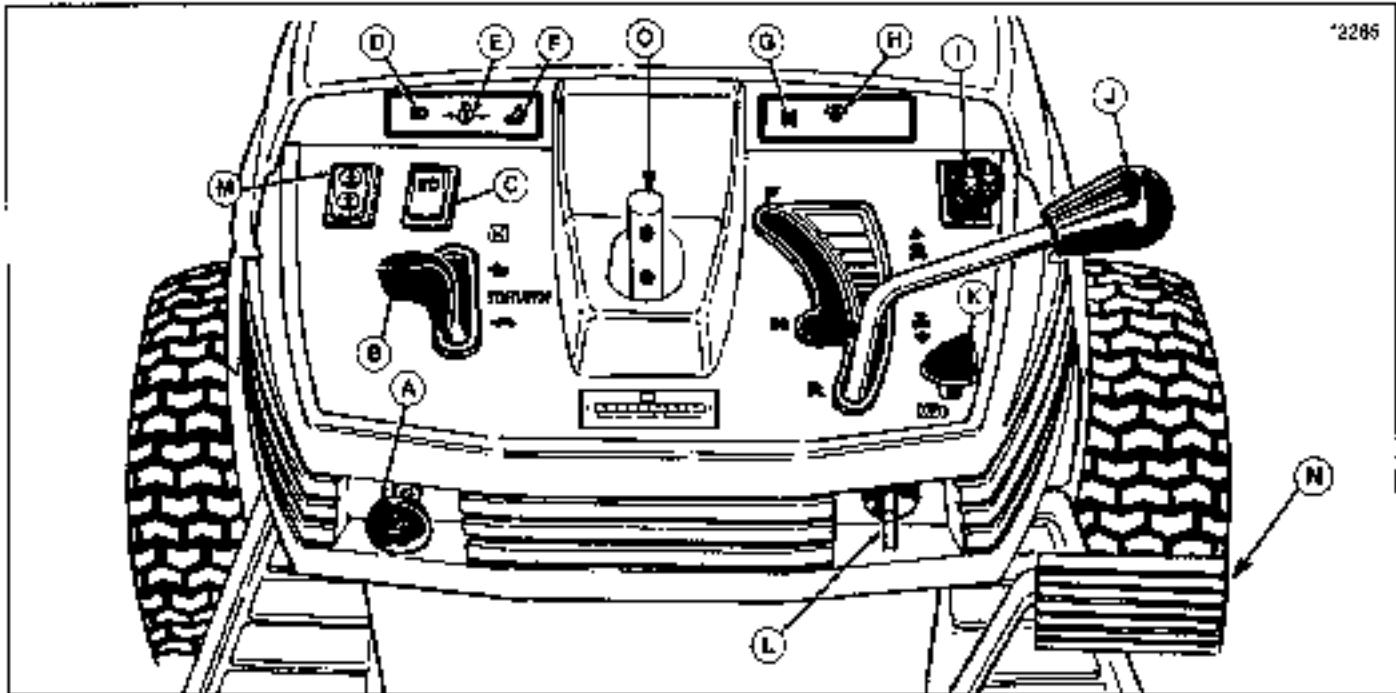

Figure 2. Tractor Controls (Hydro Model Shown)

REF	NAME	FUNCTION
A	Choke	Pull out to close choke. Aids in starting a cold engine.
B	Engine Speed Control Lever	Controls engine speed. On single cylinder models, push fully forward to close choke. For warm starts & stopping, move control lever to START/STOP position.
C	Headlight Switch	Push front down to turn headlight on, push back to turn headlight off.
D	Headlight Indicator Light (Blue)	Indicates headlights on when lit.
E	Oil Pressure Indicator Light (Red) (not on Briggs & Stratton 15 HP)	Indicates low oil pressure (when engine is running). Lights up with ignition key (L) turned on. Should go out immediately after engine starts.
F	Operator Seated Indicator Light (Green)	Indicates operator present and seat switch engaged. Must be lit for engine to start. For more details, refer to Safety Interlock System.
G	Neutral Indicator Light (Green)	Indicates transmission lever (J) is in neutral gear. Must be lit for engine to start.
H	PTO Indicator Light (Red)	Indicates PTO switch (I) is on. Must be off for engine to start.
I	PTO (Electric Clutch) Switch	Controls PTO for attachments. Pull up to engage clutch, push down to disengage. Activates PTO light (H).
J	Ground Speed Control Lever	Controls ground speed and forward/reverse motion. Push forward to go forward; pull back to go in reverse. On hydro models, ground speed is controlled by how far lever is in forward or reverse position.
K	Parking Brake Control Knob	Engages parking brake. Depress clutch/brake pedal (N) fully and pull up knob to engage parking brake. To disengage brake, depress pedal and push knob down.
L	Ignition Switch	Starts and stops the engine.
M	Mower Lift Control Lever - Electric (Standard on hydro models, optional on gear models)	Lifts and locks mower into transport position when lever is raised and moved into top position.
N	Clutch/Brake Pedal (Hydro models) Brake Pedal (Gear models, clutch pedal is located on left footrest)	Press down to disengage clutch (hydro models) and apply brake (both models). On gear models, depress clutch pedal (left side) to disengage clutch. For parking brake, depress brake pedal fully and lift control knob (K).
O	Dual Position Steering Shaft (Shown with steering wheel removed)	Steering wheel can be installed in two different positions for operator comfort.

TRACTOR & MOWER FEATURES

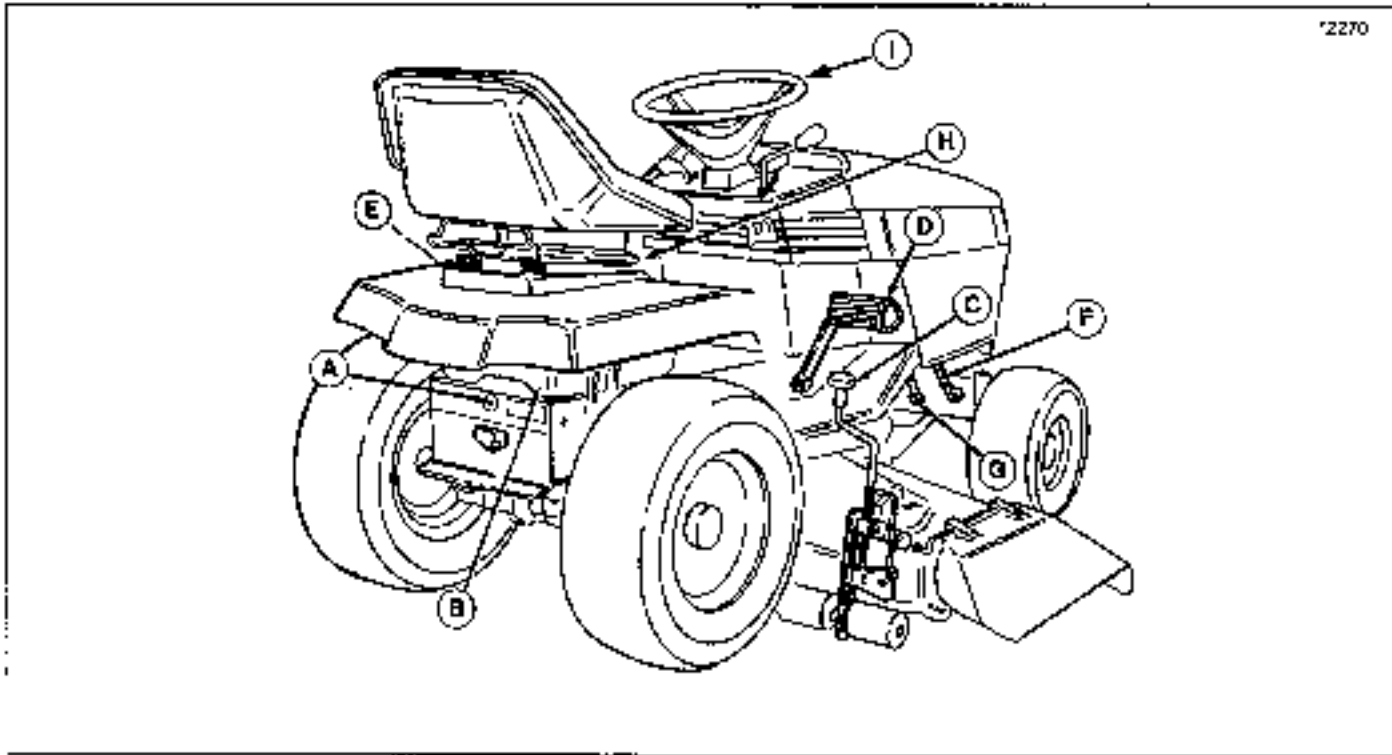

Figure 3. Tractor & Mower Features

REF.	NAME	FUNCTION
A	Transmission Release Lever (Hydro models only)	Disengages transaxle in order to push tractor by hand. See PUSHING TRACTOR BY HAND in the Operation section.
B	Fuel Tank with Gauge	4 gallon (15.1L) fuel tank with built-in gauge in filler cap (located under the seat).
C	Mower Height Adjuster	Controls height of mower cut. Infinitely adjustable from 1" to 3-5/8" cutting heights.
D	Clutch/Brake Pedal (Hydro)	Depressing pedal disengages drive belt and applies tractor brake. Depressing the pedal (in forward gears) returns the ground speed control lever (J, figure 1) to neutral. Depress pedal fully and lift control knob (K, figure 1) to lock parking brake.
D	Brake Pedal (Gear)	Depressing the pedal applies tractor brake. Depress pedal fully and lift control knob (K, figure 1) to lock parking brake.
E	Clutch Pedal (Gear)	The clutch pedal is located on the left-hand footrest. Depressing the pedal disengages the drive belt and engages the shift lockout in order to move the ground speed control lever (J, figure 1). Clutch pedal must be depressed along with the brake pedal to stop the tractor.
F	Hood Latch	Rubber straps secure hood to frame. Release strap on each side to raise engine hood.
G	Oil Drain	Oil drain extension tube allows for engine oil to be drained from underneath tractor frame.
H	Seat Lever	Releases seat for forward/back seat position.
I	Dual Position Steering Wheel	Steering wheel can be installed in two separate positions for operator comfort. See Adjustments section.

Features & Controls

ENGINE COMPARTMENT

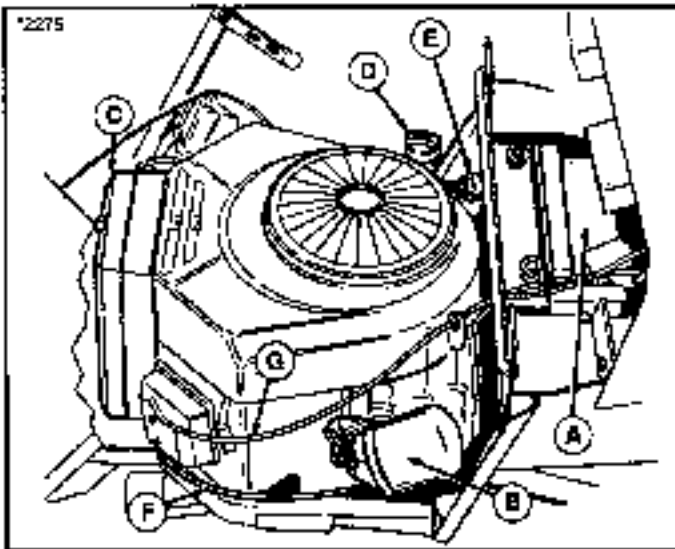

Figure 4. Engine Compartment

- A. Battery
- B. Oil Filter
- C. Air Filter
- D. Oil Fill/Dipstick
- E. Fuel Filter
- F. Throttle Cable
- G. Choke Cable

SAFETY INTERLOCK SYSTEM

Your tractor is equipped with a seat switch safety system that will automatically shut the engine off when the operator leaves the seat with the transmission control lever in gear or PTO engaged. Once the engine has stopped, the electric PTO switch must be turned off after operator returns to the seat in order to start the engine.

Check operation of dash safety lights. With operator in seat and ignition switch turned to ON (engine not running):

- A. Neutral Indicator Light (G, figure 2) should go on with transmission lever in neutral gate and should go out when lever is moved to either the forward or reverse gate.
- B. PTO Indicator Light (H, figure 2) should go on and off with operation of PTO switch.
- C. Oil Pressure Indicator Light (E, figure 2) should be on and should go out immediately after engine starts.
- D. Operator Seated Indicator Light (F, figure 2) should go on when operator is present in the seat and should go off as operator rises out of the seat.

Check the seat switch (A, figure 5) every fall and spring with the following four tests:

Test 1 - Engine should NOT crank if:

- A. seat is not occupied or

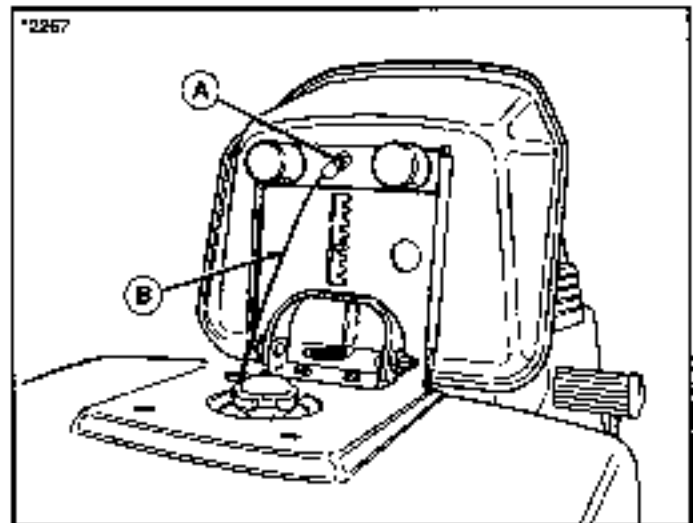

Figure 5. Seat Switch

- A. Switch
- B. Wiring Harness

- B. transmission lever out of neutral or
- C. PTO switch engaged or
- D. clutch/brake pedal not fully depressed.

Test 2 - Engine should crank if:

- A. seat is occupied and
- B. transmission lever is in neutral and
- C. PTO switch is disengaged and
- D. clutch/brake pedal is fully depressed.

Test 3 - Engine should shut off if:

- A. operator rises off seat with transmission lever in gear or
- B. operator rises off seat with clutch/brake pedal not depressed (parking brake on) or
- C. operator rises off seat with PTO engaged.

NOTE: If operator returns to seat before engine stops, the engine will re-start and electric PTO clutch will re-engage.

Test 4 - PTO will disengage if:

- A. operator rises off seat with engine running.

NOTE: If operator returns to seat before engine stops, the engine will resume speed and electric PTO clutch will re-engage.

WARNING

If the tractor does not pass the test, do not operate tractor. See your authorized dealer. Under no circumstance should you attempt to defeat the purpose of the safety system.

GENERAL

Before operating this tractor for the first time, the owner should operate in an open area without mowing, to become accustomed to the unit. The left side of the mower can be used to trim close to objects. Be sure to read all information in the Safety and Operation sections before attempting to operate this tractor and mower.

⚠ WARNING

Never allow passengers to ride on the unit.

To reduce fire hazard, keep the engine and mower free of grass, leaves and excess grease.

The interlock safety switches are for your safety. Do not attempt to bypass them.



DO NOT TOW TRACTOR

Towing the tractor will cause transmission damage. Do not use another vehicle to push or pull tractor.

⚠ WARNING - SLOPE OPERATION

Never operate on slopes greater than 30 percent (16.7°) which is a rise of three feet vertically in 10 feet horizontally. When operating on slopes that are greater than 15 percent (8.5°) but less than 30 percent use front counterweights and rear wheel weights (see your dealer). Select slow ground speed before driving onto slope. In addition to front and rear weights, use extra caution when operating on slopes with rear-mounted grass catcher. Mow UP and DOWN the slope, never across the face, use caution when changing directions and DO NOT START OR STOP ON SLOPE.

MOWER INSTALLATION

⚠ WARNING

Stop engine and remove key. Do not engage PTO until mower is completely installed and operator is seated.

NOTE: Perform mower installation on a hard, level surface such as a concrete floor.

1. Park tractor and turn off PTO switch and engine, remove the key and apply parking brake. Turn the wheels fully to the left.
2. Place mower in the lowest cutting position using the mower height adjuster (B, figure 10). Place the mower lift lever (M, figure 2 or A, figure 10) in the lowest position, also. Slide mower deck under right side of tractor so that mower hitch is aligned with front tractor hitch.
3. See figure 6. Turn wheels straight. Pull back on the spring-loaded lever (B) while lifting up on the mower hitch. Install mower hitch onto tractor hitch brackets (A). When properly installed, the spring-loaded lever should seat fully underneath the brackets.
4. **Manual Lift.** See figure 7. Position the left and right mower lift cables (A) over the lift pulleys (B) and fasten each cable to the tractor lift arm (C) using the clevis pins (D) and safety clips (E). Install clevis pins from the left side of tractor lift arms with safety clips installed on the right side of lift arms.

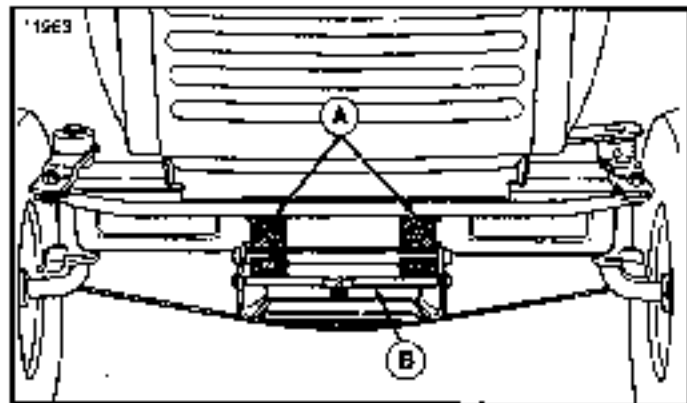

Figure 6. Mower Hitch

A. Tractor Hitch Brackets

B. Spring-Loaded Lever Brackets

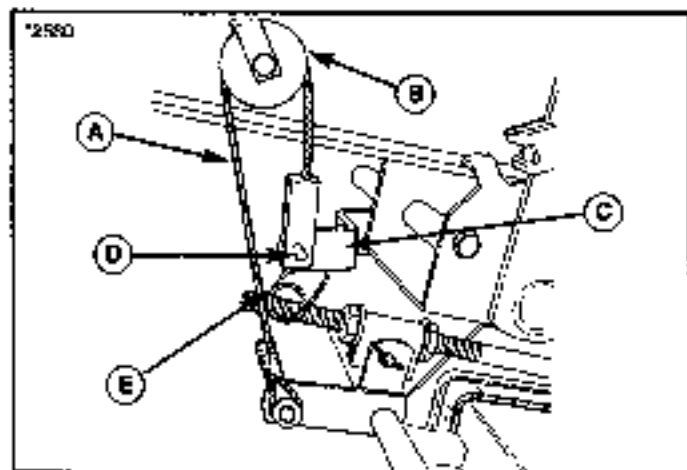

Figure 7. Mower With Manual Lift (Left Side Shown)

A. Mower Lift Cable

D. Clevis Pin

B. Lift Pulley

E. Safety Clip

C. Tractor Lift Arm

Operation

Electric Lift. See figure 8. Connect the mower lift chains (A & E) to the tractor lift arm (B) using the clevis pins, washers and safety clips. Install the shorter clevis pin (F, figure 8) on the left side as shown.

5. See figure 9. From left side of tractor, pull idler arm (A) towards you to relieve belt tension. Install belt onto the PTO pulley (B).

MOWER REMOVAL

⚠ WARNING

Stop engine and remove key. Do not engage PTO until mower is completely removed and operator is seated.

1. Park tractor on a hard, level surface such as a concrete floor. Turn off PTO switch and engine, remove the key and apply parking brake. Turn the wheels fully to the left.
2. Place mower in the lowest cutting position using the mower height adjuster (B, figure 10).
3. Place the mower lift lever (A, figure 10 or M, figure 13) in the lowest position.
4. Disconnect the mower lift arms from the tractor lift arm (figure 7 & 8). Re-install clevis pins, washers and safety clips on mower lift arms for storage.
5. Remove belt from PTO pulley.
6. Turn wheels straight ahead. Pull back on spring-loaded idler arm (A, figure 9) and lift mower hitch off of the tractor brackets.
7. Turn wheels fully left, and slide mower deck out right side of tractor.

OPERATING THE MOWER

1. When traveling to or from the work site, fully raise the mower using the mower lift lever (A, figure 10 or M, figure 13). At the work site, lower mower using the lift lever.
2. Use the mower height adjuster (B, figure 10) to set the proper mowing height. See Mowing Patterns & Tips section for cutting height recommendations.

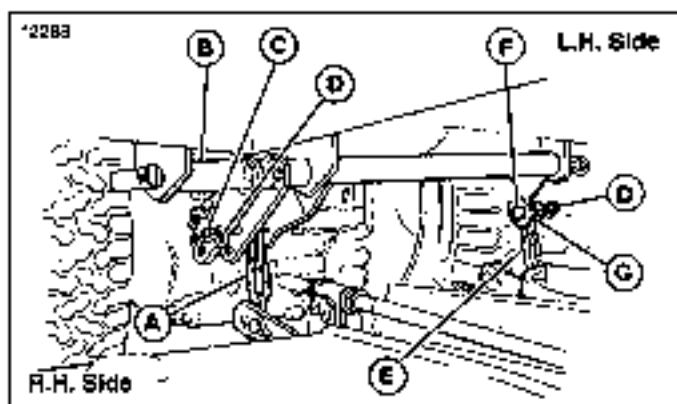

Figure 8. Mower With Electric Lift

- | | |
|---------------------------|---------------------------|
| A. Mower Lift Chain, R.H. | E. Mower Lift Chain, L.H. |
| B. Tractor Lift Arm | F. Clevis Pin, Short |
| C. Clevis Pin, Long | G. Washer |
| D. Safety Clip | |

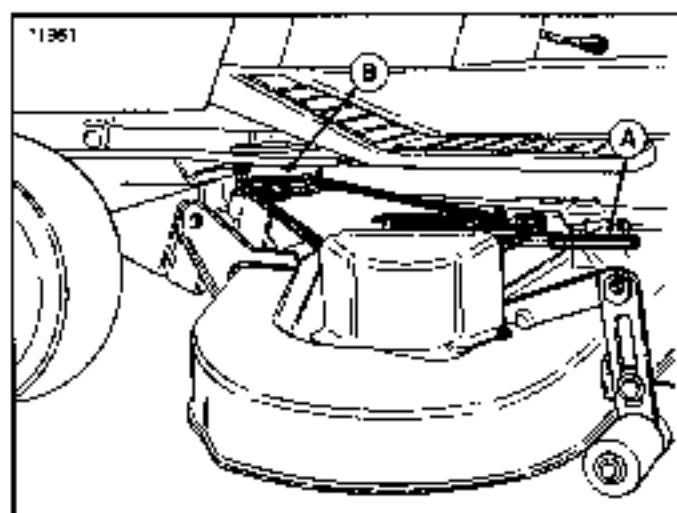

Figure 9. Installing Belt

- | | |
|--------------|---------------|
| A. Idler Arm | B. PTO Pulley |
|--------------|---------------|

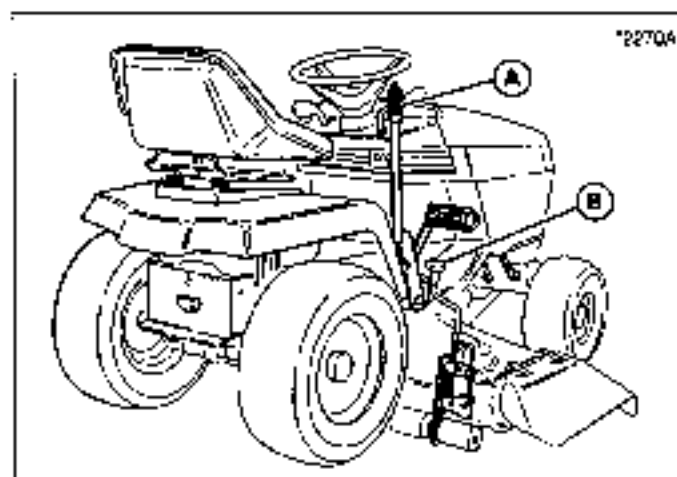

Figure 10. Mower Operation - Manual Lift

- | | |
|---------------|--------------------|
| A. Lift Lever | B. Height Adjuster |
|---------------|--------------------|

CHECKS BEFORE STARTING

1. Make sure you have proper wheel or counterweights if required. See **SLOPE OPERATION** in the Safety Rules section. Make sure any slopes are within required limits.
2. Check that crankcase is filled to full mark on dipstick. See the engine Operator's Manual for instructions and oil recommendations.
3. Make sure all nuts, bolts, screws and pins are in place and tight.
4. Make sure you can reach all controls from operator's positions. If not, see **SEAT ADJUSTMENT**.
5. Fill the gasoline tank with fresh gasoline. Fill to bottom of filler neck to avoid spillage and overflow. **DO NOT** mix oil with gasoline. Refer to engine manual for gasoline recommendations.

⚠ WARNING

Gasoline is highly flammable and must be handled with care. Never fill the tank when the engine is still hot from recent operation. Do not allow open flame, smoking or matches in the area. Avoid over-filling and wipe up any spills.

CLUTCH/BRAKE PEDAL - HYDRO MODELS

1. See figure 11. Depressing the pedal to position A disengages the transmission drive and, when in a forward gear, returns the transmission control lever to neutral. Fully depressing the pedal to position B applies the tractor brake.
2. Parking brake is applied at pedal position B when parking brake control knob (C, figure 11) is pulled up with pedal fully depressed.

CLUTCH & BRAKE PEDALS - GEAR MODELS

1. See figure 12. Depressing the clutch pedal from position A to B activates neutral start circuit, disengages the transmission drive belt and allows the gear lever to be shifted. Clutch pedal must be used with the brake pedal to stop the tractor.
2. See figure 11. Depressing the brake pedal from position A to B applies the tractor brake. Parking brake is applied at position B when parking brake control knob (C) is pulled up with pedal depressed.

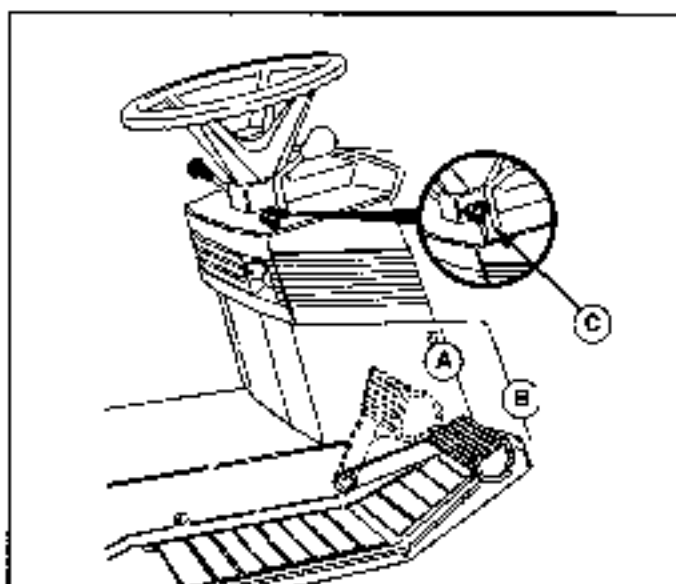

Figure 11. Clutch/Brake Pedal and Parking Brake (Brake Pedal Only - Gear Models)

- A. Clutch disengages
B. Brake is applied
C. Parking Brake Knob

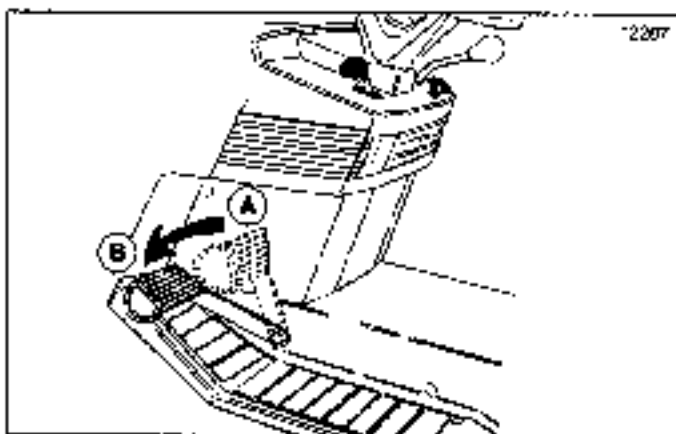

Figure 12. Clutch Pedal - Gear Models

Operation

STARTING THE ENGINE

Refer to figure 13.

1. Seat yourself on the tractor seat in the operating position. Set the parking brake using the brake pedal (N) and parking brake knob (K).
2. Push down on the switch (I) to disengage the PTO and place the ground speed control lever (J) in neutral.
3. For cold starts, pull choke knob (A) to the choke position. For warm starts, leave choke knob pushed in.
4. Turn the key (L) to start and release when engine has started.
5. Move the engine speed control lever (B) to the slow position. Warm up the engine by running it for at least a minute before engaging the PTO or driving the tractor.

SELECTING GROUND & ENGINE SPEED

On hydro models, ground speed is infinitely variable according to how far the control lever (J, figure 13) is moved in the forward or reverse position.

On gear models, ground speed is selected by depressing the clutch pedal and moving the control lever (J, figure 13) to the appropriate gear selection.

Most mowing is done in 3rd or 4th gear with engine speed between 3/4 and full speed. If the terrain is rough, hilly or sloping, use first or second gear. If the grass is wet or over 3" (76mm) high, use full engine speed (with low gear) so the mower will have enough power to cut the grass.

WARNING

Make sure desired direction of travel is clear of objects, people and animals.

1. If you are ready to mow, lower the mower from the transport position using mower lift lever (A, figure 11 or M, figure 13) and set the mowing height using the

mowing height adjuster (B, figure 11).

2. Set the engine speed control lever (B, figure 13) for full speed.
3. Use the PTO switch (I) to engage the PTO.
4. Release the parking brake by depressing brake pedal (N, figure 13) and pushing knob (K) down.
5. On hydro models, move the ground speed control lever (J, figure 13) to the desired direction and speed of travel to set the tractor in motion.

On gear models, depress clutch pedal, use the ground speed control lever to select the proper gear for conditions, then slowly release clutch pedal to set the tractor in motion.
6. Adjust engine speed control lever (B, figure 13) to the desired speed. Between 3/4 and full speed is recommended for mowing.

STOPPING THE TRACTOR

1. **On hydro models,** move the ground speed control lever (J, figure 13) into the NEUTRAL position to make a gradual stop. To make a more rapid stop, depress the clutch/brake pedal (N, figure 13).

NOTE: On hydro models, the ground speed control lever will return to neutral from a forward gear when the clutch/brake pedal is depressed.

On gear models, press the clutch pedal (N, figure 13) down to disengage the clutch for a gradual stop. For a more rapid stop, press the brake pedal down to apply the brake while also depressing clutch pedal to disengage the PTO. Move the ground speed control lever to NEUTRAL before releasing the pedals.

2. Engage the parking brake by fully depressing brake pedal and pulling up on parking brake knob (K, figure 13).
3. Use the PTO switch (I, figure 13) to disengage the PTO.
4. Set the engine speed control lever (B, figure 13) to 1/2 throttle setting and allow the engine to idle for 20 seconds. Stopping a hot engine too fast may cause engine damage.
5. Turn key (L, figure 13) to OFF and remove it.

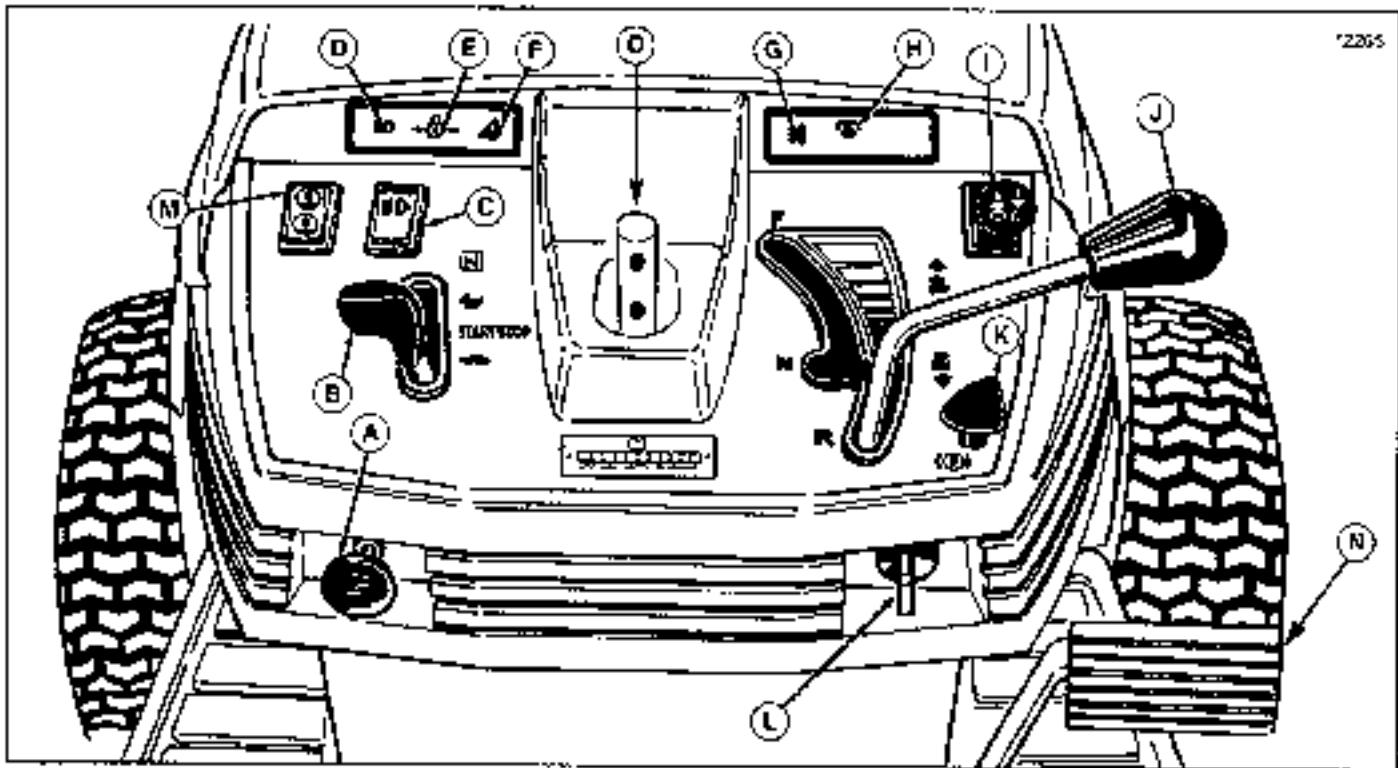

Figure 13. Tractor Controls (Hydro Model Shown)

- A. Choke
- B. Engine Speed Control Lever
- C. Headlight Switch
- D. Headlight Indicator Light (Blue)
- E. Oil Pressure Indicator Light (Red)
- F. Operator Seated Indicator Light (Green)
- G. Neutral Indicator Light (Green)
- H. PTO Indicator Light (Red)
- I. PTO Switch
- J. Ground Speed Control Lever
- K. Parking Brake Knob
- L. Ignition Switch
- M. Electric Mower Lift Lever (Hydro only)
- N. Clutch/Brake Pedal (Hydro models)
Brake Pedal (Gear models)
- O. Dual Position Steering Shaft

⚠ WARNING

Before leaving the operator's position for any reason, engage the parking brake, disengage the PTO, stop the engine and remove the key.

⚠ WARNING

To reduce fire hazard, keep the engine, tractor and mower free of grass, leaves and excess grease. Do not stop or park tractor over dry leaves, grass or combustible materials.

Operation

PUSHING THE TRACTOR BY HAND

Hydro Models

1. With engine off and key removed, use the PTO switch (I, figure 13) to disengage the PTO.
2. Place the mower in the transport position (up) using the mower lift lever (A, figure 10 or M, figure 13).
3. See figure 14A. To push the tractor by hand, the release lever must be placed in the PUSH position. Pull release lever handle out and down until lever locks in fully released position.
4. See figure 14B. To drive the tractor, release lever must be moved to the DRIVE position by pushing lever up and in until lever locks in DRIVE position.

Gear Model

1. With engine off and key removed, use the PTO switch (I, figure 13) to disengage the PTO.
2. Place the mower in the transport position (up) using the mower lift lever (A, figure 10 or M, figure 13).
3. Place the ground speed control lever (J, figure 13) in the neutral position.
4. Unlock the parking brake.

WARNING

Do not tow the tractor. Damage will result to the transmission/transaxle.

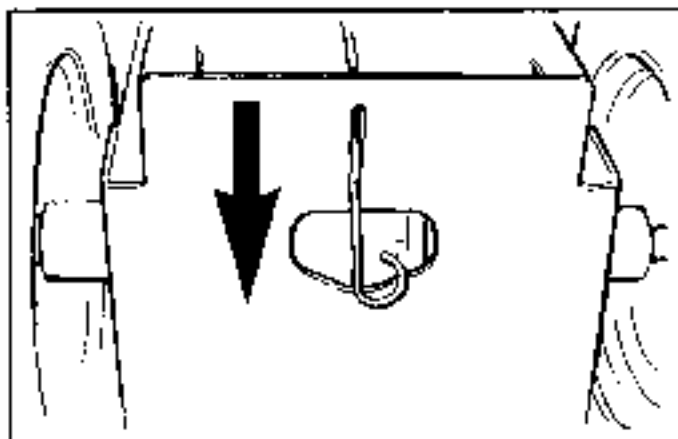

Figure 14A. Hydro Transaxle Release Lever - Push Position

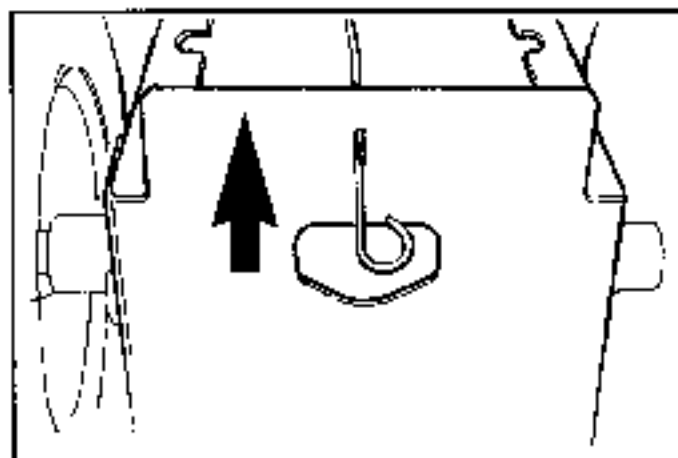

Figure 14B. Hydro Transaxle Release Lever - Drive Position

Mowing Patterns & Tips

GENERAL

For the first use of the mower, choose a smooth level area. Cut long straight strips overlapping slightly.

The size and type of area to be mowed determines the best mowing pattern to use. Obstructions such as trees, fences and buildings must also be considered. Where possible, make one or two passes in a counterclockwise direction around the outside of the area to keep the cut grass off fences and walks. The remainder of the mowing should be done in a clockwise direction so the clippings are dispersed on the cut area.

Keep in mind the following lawn care and mowing tips:

- Too much maintenance is as detrimental to your lawn as neglect.
- Mow when grass is 3-5 inches tall. Don't cut shorter than 2 to 2-1/2 inches. Cut only the top one-third of the grass blade. Cutting below this level can lead to thatch problems. Your mower has a cutting height adjustment that can help you maintain a proper length.
- For extremely tall grass, set the cutting height at maximum for the first pass, and then reset to the desired height and mow again.
- Mow often. Short clippings of an inch or less decompose more quickly than longer blades.
- Keep the blades on your mower sharp for finer clippings.
- Let grass grow a bit longer when it is hot to reduce heat build-up and protect grass from heat damage.
- Use slow-release fertilizer for slow, even growth.
- Don't cover grass surface with a heavy layer of clippings. Consider using a grass collection system and starting a compost pile.
- Aerate lawn in spring, consider renting an aerator which removes cores of soil from the lawn. This increases the speed of clipping decomposition and deep root growth by opening up the soil and permitting greater movement of water, fertilizer and air.
- Don't over-water. Too much water can encourage disease development.
- Mow when the grass is dry, preferably in the late afternoon when the temperatures are cooler.
- Where possible, change patterns occasionally to eliminate matting, graining or a corrugated appearance.
- For wet grasses, grasses prone to wheel tracking and for collecting clippings:
 - a. Use sharp blades.
 - b. Raise deck 1/4" higher in front than in rear.
 - c. Run at maximum engine speed but slow ground speed.
 - d. Clean deck of built-up material/caked-on grass.
 - e. Check for free movement of mower idler pulley.

- For dry conditions where grass blow-out is a problem:
 - a. Use sharp blades.
 - b. Raise deck so the front is even with, or 1/8" lower than, rear.
 - c. Use 3/4 engine speed.
 - d. Clean deck of built-up material/caked-on grass.

MULCHING MOWER OPERATION (OPTIONAL KIT ATTACHMENT)

Mulching

Mulching consists of actually cutting and recutting clippings into tiny particles and blowing them into the lawn. These tiny particles decompose rapidly into by-products your lawn can use. Under proper conditions, your mulching mower will virtually eliminate noticeable clippings on the lawn surface.



Keep in mind these mulching tips:

- Use mulching mower or mulcher kit without shredders for grass mulching.
- Install shredders for leaf shredding.
- Use maximum engine speed.
- Raise height of cut if excessive power is used.
- Must use sharp blades. Do not use lift tabs or high lift blade when mulching.
- Adjust to lower ground speeds in heavy grass or if windrow is present.
- Clean deck of built-up material/caked-on grass.
- Check for free movement of mower idler pulley.

Mowing Conditions

The best mulching results from mowing when lawn is dry and grass blades are not over 5" long. Follow these guidelines for best results:

- Do not use the mower as a mulching mower during the first two or three mowings in the spring. The long grass blades, quick growth, and often wetter conditions are more suitable for side-discharge (broadcasting) or grass bagging operation.
- Avoid mulching after rain or heavy dew. It may be better to mow later in the day or early evening when lawn is drier.
- Change the mowing pattern each time.

Mowing Patterns & Tips

- If mulching baffles are removed, the original deflector must be in operating position for safe side-discharge mowing.

How Much Grass To Cut Off

Removing too much grass height in one cutting may result in an unsatisfactory cut: windrowing, clumping, or uneven dispersal of clippings may result. It is best to mow when the grass is between 3" - 5" tall, although this will depend on your personal preference for lawn appearance. A good rule to follow is to cut only the top one-third of the grass blade at a time (maximum of 1-1/2"). Cutting more off the grass blade, particularly in wet spring conditions, can lead to thatch problems.

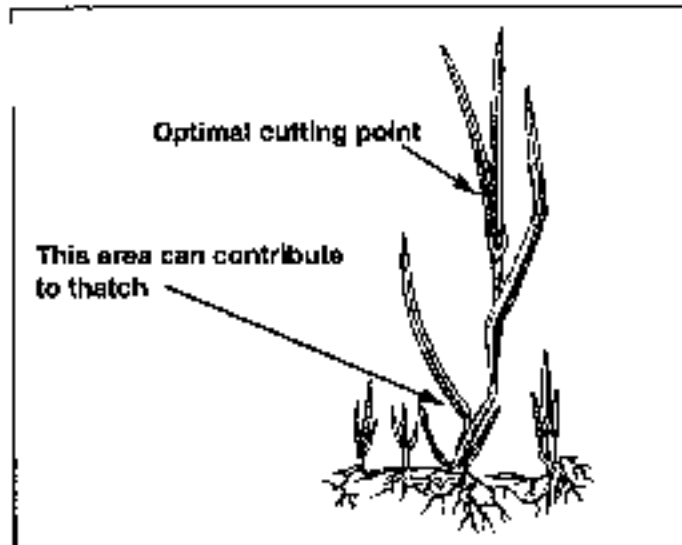

Engine Speed & Ground Speed

Use full engine throttle matched with a slower ground speed so that clippings will be finely cut. A better cut may result from cutting the same area in two passes, each time cutting only 3/4" of grass blade. Short clippings of 1" or less decompose more quickly than longer blades.

NOTE: When mulching under heavy cutting conditions, a rumbling sound may be present and is normal.

The Proper Equipment

Always keep the mower blades sharp and balanced. Blades should be sharpened at the beginning of every mowing season. If the tips of grass blades brown after cutting, this may be a sign of dull blades tearing, rather than cutting, the grass blades.

Keep the underside of the mower deck and baffles clean so that clippings are properly circulated, chopped, and discharged back into the lawn.

The Best Combination

We recommend that you experiment with the height of cut position and tractor ground speed that will give you the best cut. Start with a higher cutting height and try increasing lower settings until you find a cutting height that is matched to your mowing conditions and preferences. Since mulching requires more horsepower than side-discharging, using a slower ground speed is important for proper mulching operation.

Clippings Are Beneficial

A common misconception about clippings is that they automatically lead to thatch. However, clippings produced by mulching methods actually contribute to a healthy lawn because they:

- Act as a safe, non-polluting and inexpensive fertilizer that nourishes your lawn. Fresh cut blades are a rich source of nitrogen which is essential to lush growth. And one garbage bag of clippings contains about 1/4 lb. of usable organic nitrogen.
- Reduce the evaporation of water from your lawn.
- Provide a cushioning layer to reduce lawn wear.
- Moderate soil temperature.
- Save money normally spent on trash bags.

Leaf Shredding

(For use with Mulcher Kit Only)

Patented Shredder Blades virtually eliminate raking leaves. Up to 512 cutting edges pulverize leaves into tiny particles, which quickly and naturally decompose into food for your lawn. Shredder Blades must be removed when you choose to mulch grass clippings.

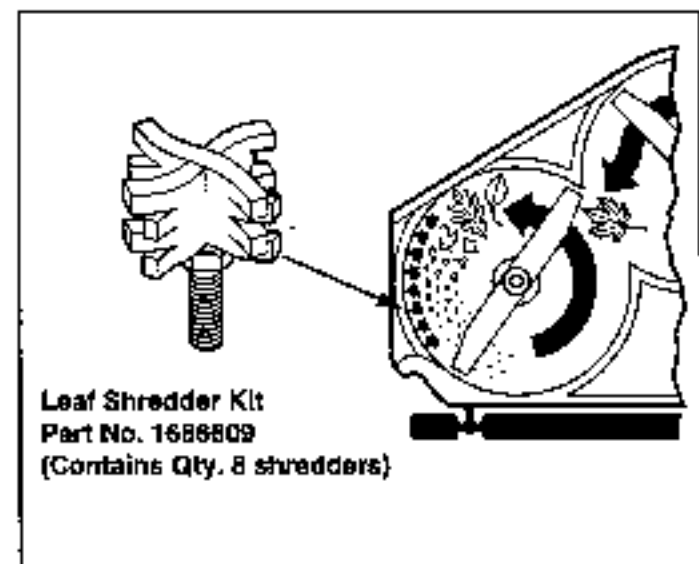

SCHEDULE

The following schedule should be followed for normal care of your tractor and mower. You will need to keep a record of your operating time. Determining operating time is easily accomplished by multiplying the time it takes to do one job by the number of times you've done the job, or you can install the optional hour meter.

Safety Items	See Page	Before First Use	Before Each Use	Every 5 Hours	Every 25 Hours	Every 100 Hours	Spring & Fall	
Check safety interlock system.	8	•					•	
Check tractor brakes.	27	•					•	
Check mower blade stopping time.	29	• After adjustment or service of electric PTO clutch •						
Normal Care Items								
Check tractor & mower for loose hardware.	-	•	•	•				
Check engine oil level.	*	•	•	•			•	
Check engine & air filter.	*				***			
Change engine oil and filter.**	*				**Every 50 hrs		***•	
Lubricate tractor & mower.	18-19				***•			
Check fluid levels & tire pressure	17	•	•		**•			
Change transmission fluid. (Hydro only)****	-	Only if transaxle is serviced or every 400 hours.						
Check fuel filter.	18					•		
Clean battery & cables	19					•		
Clean/sharpen blades.	20					•		
Inspect spark plug(s).	*					•		

* See the engine manufacturer's owner's manual.

** Change original engine oil after first 5 hours of operation.

*** More often in hot (over 85° F; 30° C) weather or dusty operating conditions.

**** Fluid and filter should be changed when performing repair work or if fluid has become discolored from overheating or contamination.

RAISING THE HOOD

To gain access to the engine compartment, release the rubber strap (D, figure 3) on each side of the hood and raise the hood.

CAUTION

Do not run the engine with the hood raised. Engine heat will cause damage to the headlight bezel and hood.

CHECKING/ADDING GASOLINE

Check the gas gauge/cap to be sure there is enough gasoline to complete the job. To add gasoline, remove the gas gauge/cap. Do not overfill. Leave room in the tank for fuel expansion. Refer to your engine manual for gasoline recommendations. Install and hand tighten the gas gauge/cap.

CAUTION

Never use gasoline containing METHANOL, gasoline containing more than 10% ethanol, gasoline additives, premium gasoline, or white gas because engine/fuel system damage could result.

CHECKING TIRE PRESSURE

Front tire pressure should be 12 to 15 psi (82 to 103 kPa). Rear tire pressure should be 6 to 8 psi (41 to 55 kPa).

CHECKING FUEL FILTER

WARNING

Do not remove fuel filter when engine is hot, as spilled gasoline may ignite. DO NOT spread hose clamps further than necessary. Ensure clamps grip hoses firmly over filter after installation.

The fuel filter is located in fuel line between fuel tank and carburetor. If filter is dirty or clogged, replace as follows. Place a container below filter to catch spilled gasoline.

- Using a pliers, open and slide hose clamps from fuel filter.
- Remove hoses from filter.
- Install new filter in proper flow direction in fuel line. Secure with hose clamps. See warning at beginning of procedure.

Normal Care

LUBRICATION

Lubricate the tractor and mower deck as shown in figures 15 - 21. When a grease gun is shown, wipe the fitting clean, apply two or three shots of lithium base automotive grease, and wipe off excess grease. When an oil can is shown, wipe the area clean, apply a few drops of oil (SAE 30), then wipe up drips or spills.

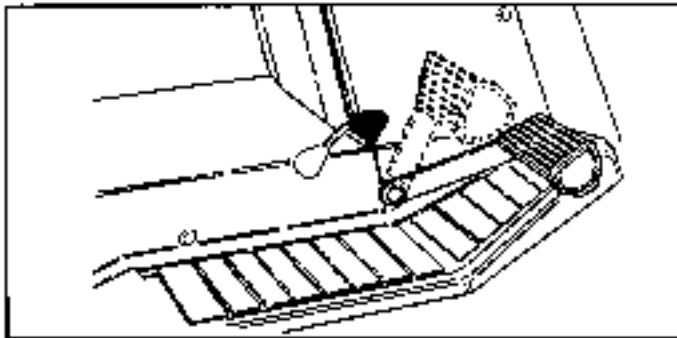

Figure 15. Brake Pedal Pivot Point

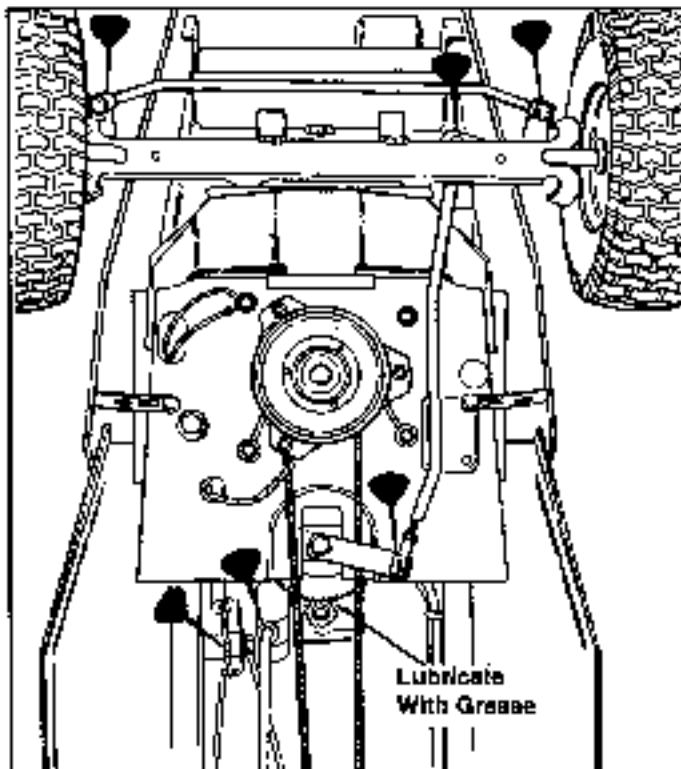

Figure 16. Tractor Lubrication Points - Front Half

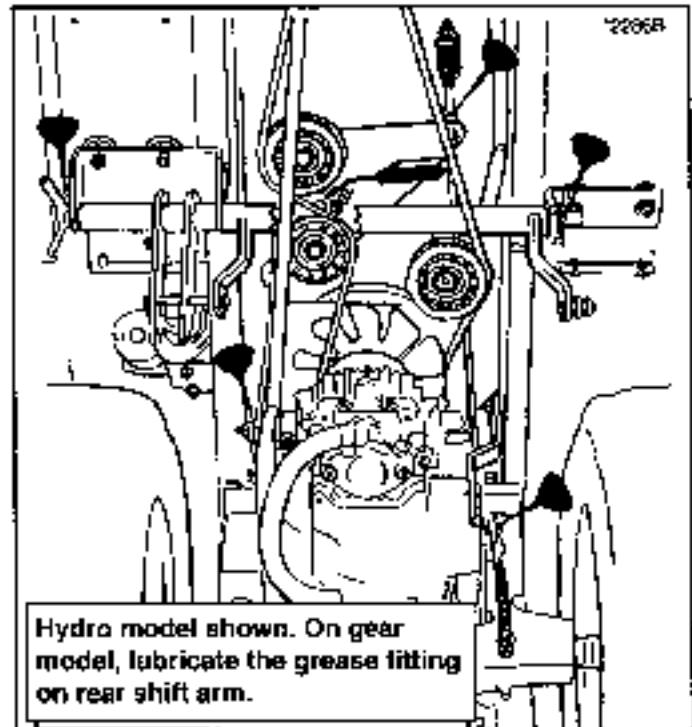

Figure 17. Tractor Lubrication Points - Rear Half

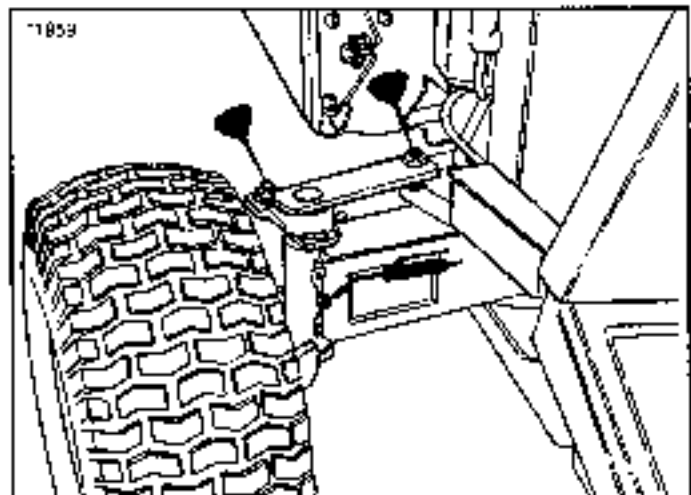

Figure 18. Front Axle Lubrication Points

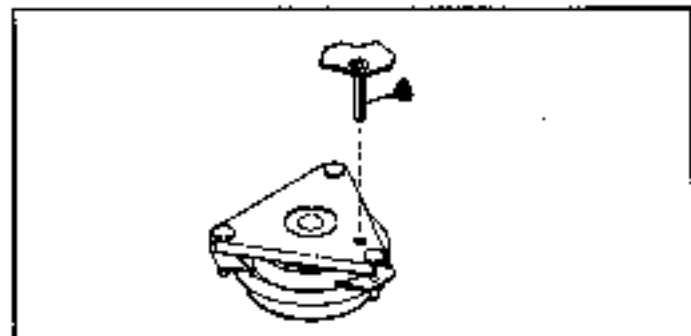

Figure 19. PTO Lubrication

BATTERY MAINTENANCE

Checking the Battery Fluid

1. Raise the hood.
2. Remove battery filler cap. Fluid must be even with spilling full mark. If not, add distilled water.
3. Reinstall filler cap.

Cleaning the Battery and Cables

⚠ WARNING

Be careful when handling the battery. Avoid spilling electrolyte. Keep flames and sparks away from the battery.

⚠ WARNING

When removing or installing battery cables, disconnect the negative cable FIRST and reconnect it LAST. If not done in this order, the positive terminal can be shorted to the frame by a tool.

1. Disconnect the cables from the battery, negative cable first (B, figure 22).
2. Remove the battery clamp, then remove the battery.
3. Scrub the battery, cables and battery compartment with baking soda and water.
4. Clean the battery terminals and cable clamps with a wire brush and battery post terminal cleaner.
5. Reinstall battery and clamp.
6. Connect cables, positive cable first.
7. Coat cable clamps and terminals with grease or petroleum jelly.

SERVICING THE MOWER BLADES

⚠ WARNING

For your personal safety, do not handle the sharp mower blades with bare hands. Careless or improper handling of blades may result in serious injury.

1. Remove mower from the tractor.
2. Blades should be sharp and free of nicks and dents. If not, sharpen blades as described in following steps.
3. To remove blade for sharpening, use wooden block to hold blade while removing the blade mounting cap-screw (figure 23).
4. Use a file to sharpen blade to fine edge. Remove all nicks and dents in blade edge. If blade is severely damaged, it should be replaced.

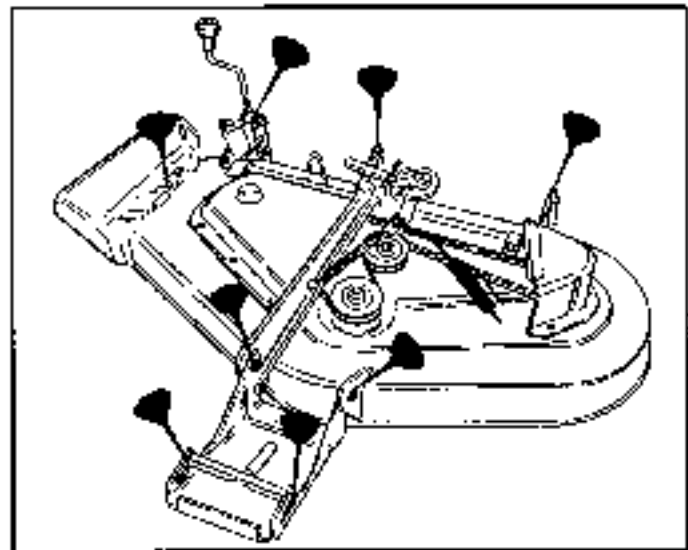

Figure 20. Mower Lubrication Points

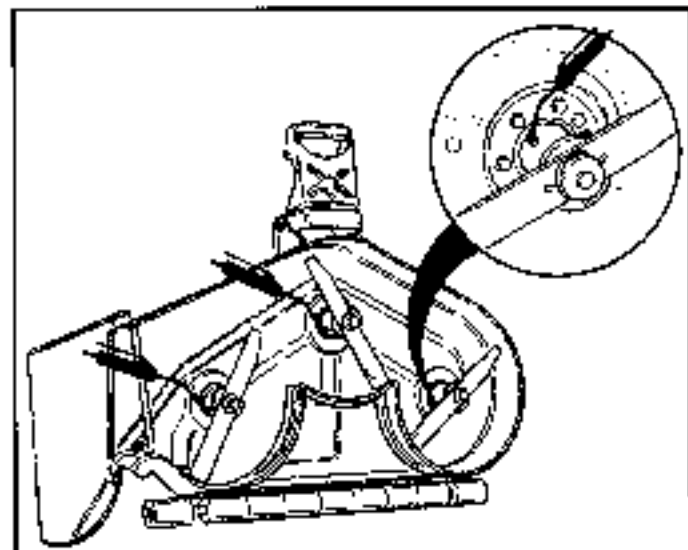

Figure 21. Arbor Lubrication Points

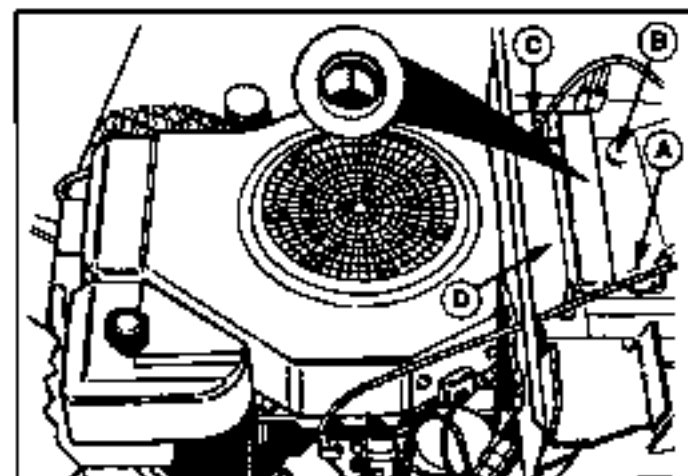

Figure 22. Battery
 A. Positive Battery Terminal C. Hold Down Rod
 B. Negative Battery Terminal D. Battery Clamp

Normal Care

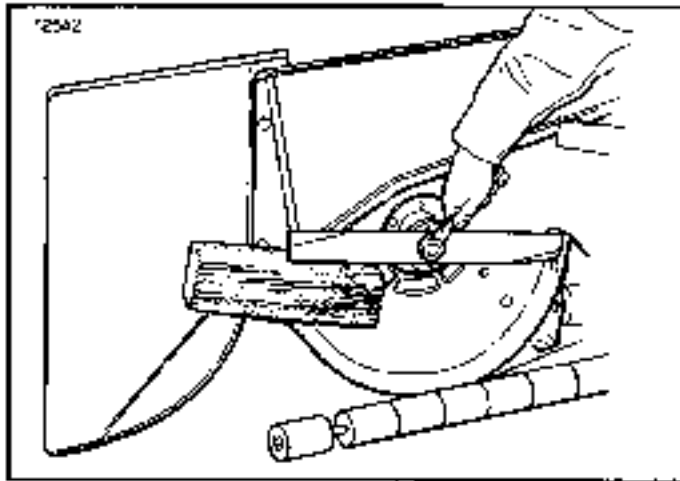

Figure 23. Removing The Blade

5. Balance the blade as shown in figure 24. Center the blade's hole on a nail lubricated with a drop of oil. A balanced blade will remain level.
6. Reinstall each blade with the tabs pointing up toward deck as shown in figure 25. Secure with a cap screw (D), cup washer (C) and spline washer (B). Use a wooden block to prevent blade rotation and torque cap screws to 50-70 ft. lbs. (67-95 N.m.).

⚠ WARNING

For your personal safety, blade mounting cap screws must each be installed with a cup washer and spline washer, then securely tightened. Torque blade mounting cap screw to 50-70 ft. lbs. (67-95 N.m.)

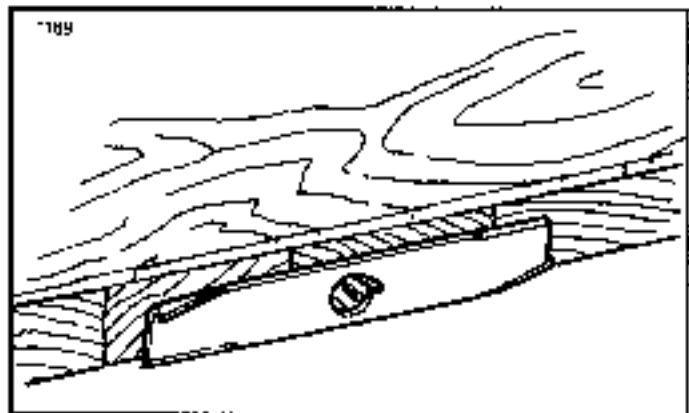

Figure 24. Balancing The Blade

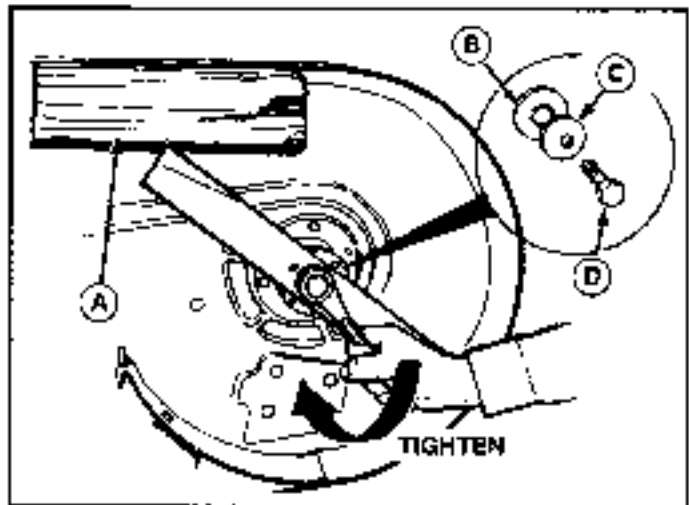

Figure 25. Installing The Blade

- | | |
|------------------|---------------|
| A. Wooden Block | C. Cup Washer |
| B. Spline Washer | D. Cap screw |

CHECKING TRANSMISSION FLUID

Transmission fluid should be checked with the engine off. Remove plug (figure 26A). Fluid level should be to the bottom of the hole. If fluid level is low, add fluid (10W 40 oil) to the fill tube (figure 26B) until proper level is reached, then reinstall drain plug.

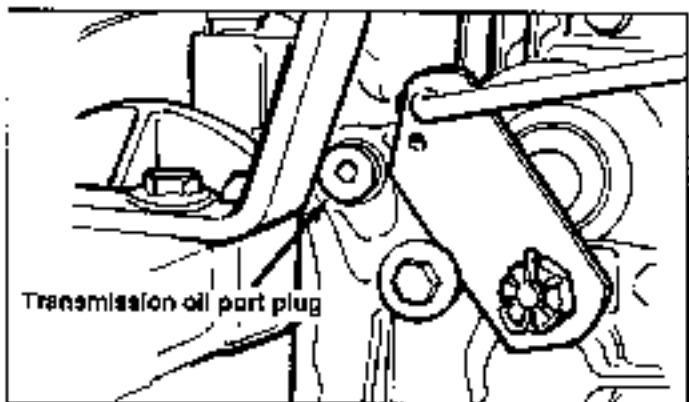

Figure 26A. Transmission Oil Port Plug

CHANGING TRANSMISSION FLUID & FILTER

Transmission fluid and filter should be changed when performing repair work or if fluid has become discolored from overheating or contamination. Perform fluid and filter change every 400 hours of operation if no other service to the transmission has been performed.

Replace the transmission filter whenever changing transmission fluid. Make sure filter base and surrounding area is absolutely clean before removing and replacing filter.

To drain transmission fluid:

1. Remove transmission filter and drain fluid into suitable container. Reinstall new filter.
2. Remove oil port plug (figure 26A).
3. Add 10W 40 oil (76 oz.) to the transmission fluid fill tube (figure 26B) until oil just starts to run out of the oil port (figure 26A). Reinstall oil port plug.
4. Run the tractor for several minutes until transmission is warm, then re-check fluid level as described previously under CHECKING TRANSMISSION FLUID.

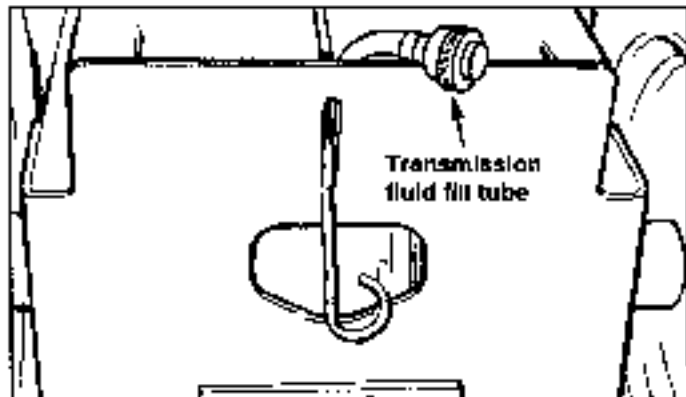

Figure 26B. Transmission Fluid Fill Tube Located at Rear of Tractor

Storage

WARNING

Never store the tractor, with gasoline in engine or fuel tank, in a heated shelter or in enclosed, poorly ventilated enclosures. Gasoline fumes may reach an open flame, spark or pilot light (such as a furnace, water heater, clothes dryer, etc.) and cause an explosion.

Handle gasoline carefully. It is highly flammable and careless use could result in serious fire damage to your person or property.

Drain fuel into an approved container outdoors away from open flame or sparks.

TEMPORARY STORAGE (30 Days Or Less)

Remember, the fuel tank will still contain some gasoline, so never store the tractor indoors or in any other area where fuel vapor could travel to any ignition source. Fuel vapor is also toxic if inhaled, so never store the tractor in any structure used for human or animal habitation.

Here is a checklist of things to do when storing your tractor temporarily or in between uses:

- Keep the tractor in an area away from where children may come into contact with it. If there's any chance of

unauthorized use, remove the spark plug (s) and put in a safe place. Be sure the spark plug opening is protected from foreign objects with a suitable cover.

- If the tractor can't be stored on a reasonable level surface, check the wheels.
- Clean all grass and dirt from the mower.

NOTE: If storing your tractor between winter snow removal jobs in a cold area, we suggest that you fill the fuel tank at the completion of each job to prevent water condensation in the fuel tank. Wait for engine to cool before filling tank.

Storage

LONG TERM STORAGE (Longer Than 30 Days)

Before you store your tractor for the off-season, read the Maintenance and Storage instructions in the Safety Rules section, then perform the following steps:

1. Drain crankcase oil while engine is hot and refill with a grade of oil that will be required when tractor is used again.
2. Prepare the mower deck for storage as follows:
 - a. Remove mower deck from the tractor.
 - b. Clean underside of mower deck
 - c. Coat all bare metal surfaces with paint or light coat of oil to prevent rusting.
3. Clean external surfaces and engine.
4. Prepare engine for storage. See engine owner's manual.
5. Clean any dirt or grass from cylinder head cooling fins, engine housing and air cleaner element.
6. Cover air cleaner and exhaust outlet tightly with plastic or other waterproof material to keep out moisture, dirt and insects.
7. Completely grease and oil tractor as outlined in the Normal Care section.
8. Clean up tractor and apply paint or rust preventative to any areas where paint is chipped or damaged.
9. Be sure the battery is filled to the proper level with water and is fully charged. Battery life will be increased if it is removed, put in a cool, dry place and fully charged about once a month. If battery is left in tractor, disconnect the negative cable.
10. Drain fuel system completely or add a gasoline stabilizer to the fuel system. If you have chosen to use a fuel stabilizer and have not drained the fuel system, follow all safety instructions and storage precautions in this manual to prevent the possibility of fire from the ignition of gasoline fumes. Remember, gasoline fumes can travel to distant sources of ignition and ignite, causing risk of explosion and fire.

NOTE: Gasoline, if permitted to stand unused for extended periods (30 days or more), may develop gummy deposits which can adversely affect the engine carburetor and cause engine malfunction. To avoid this condition, add a gasoline stabilizer to the fuel tank or drain all fuel from the system before placing unit in storage.

11. Transport the tractor to a suitable, dry, indoor location. If the tractor is to be stored 6 months or longer, block the tractor up off the wheels to relieve weight and also to keep the tires off a damp floor. Protect tires from prolonged exposure to direct sunlight

STARTING AFTER LONG TERM STORAGE

Before starting the tractor after it has been stored for a long period of time, perform the following steps.

1. Remove the blocks from under the tractor.
2. Install the battery if it was removed.
3. Unplug the exhaust outlet and air cleaner.
4. Fill the fuel tank with fresh gasoline. See engine manual for recommendations.
5. Check crankcase oil level and add proper oil if necessary.
6. Inflate tires to proper pressure. Check fluid levels.
7. Start the engine and let it run slowly. DO NOT run at high speed immediately after starting. Be sure to run engine only outdoors or in well ventilated area.

GENERAL

WARNING

To avoid serious injury, perform maintenance on the tractor or mower only when the engine is stopped and the parking brake engaged. Always remove the ignition key, disconnect spark plug wire and fasten away from the plug before beginning the maintenance, to prevent accidental starting of the engine.

This section of the manual provides troubleshooting and repair instructions for the more common and easily corrected problems. For other problems, it is recommended that you contact your dealer. Locate the problem that best describes the trouble that you have encountered. Check the possible causes one at a time, in the order that they are listed.

TROUBLESHOOTING THE TRACTOR

Engine will not turnover or start.

1. Ground speed control lever not in neutral-start position. Shift into neutral.
2. PTO (electric clutch) switch in ON position. Place in OFF position.
3. Out of fuel. If engine is hot, allow it to cool, then refill the fuel tank.
4. Engine flooded. Push choke knob in (twin cylinder models) or move throttle control out of CHOKE position (single cylinder models).
5. Circuit breaker tripped. Wait one minute for automatic reset. Replace if defective (see your dealer).
6. Battery terminals require cleaning. See Normal Care section.
7. Battery discharged or dead. Recharge or replace.
8. Wiring loose or broken. Visually check wiring & replace broken or frayed wires. Tighten loose connections.
9. Solenoid or starter motor faulty. Repair or replace.
10. Safety interlock switch or module faulty. Replace if needed (see your dealer.)
11. Spark plug(s) faulty, fouled or incorrectly gapped. Clean and gap or replace. See engine manual.
12. Water in fuel. Drain fuel & refill with fresh fuel.
13. Old stale gas. Drain fuel & replace with fresh fuel.
14. Foot pedal not depressed.

Engine starts hard or runs poorly.

1. Fuel mixture too rich. Clean air filter. Check choke

- adjustment (engine speed control). See engine manual.
2. Carburetor adjusted incorrectly. See engine manual.
3. Spark plug(s) faulty, fouled, or incorrectly gapped. Clean and gap or replace. See engine manual.

Engine knocks.

1. Low oil level. Check/add oil as required.
2. Using wrong grade oil. See engine manual.

Excessive oil consumption.

1. Engine running too hot. Clean engine fins, blower screen and air cleaner.
2. Using wrong weight oil. See engine manual.
3. Too much oil in crankcase. Drain excessive oil.

Engine exhaust is black.

1. Dirty air filter. Clean air filter. See engine manual.
2. Check engine speed control adjustment (choke) See engine manual.

Engine runs, but tractor will not drive.

1. Ground speed control lever in neutral. Shift in forward or reverse.
2. (Hydro models only) Transmission release lever in "push" position. Move into drive position.
3. Belt is broken. See Drive Belt Replacement.
4. Drive belt slips. See problem and cause below.
5. Brake is not fully released. See Brake Adjustment.

Tractor drive belt slips.

1. Clutch is out of adjustment. See your dealer.
2. Pulleys or belt greasy or oily. Clean as required.
3. Belt stretched or worn. Replace with correct belt.
4. Idler pulley pivot bracket "frozen" in declutched position. Remove idler pulley, clean and lubricate.

Brake will not hold.

1. Brake is incorrectly adjusted. See Brake Adjustment.
2. Internal brake disc on transaxle worn. See your dealer.

Tractor steers hard or handles poorly.

1. Steering linkage is loose. Check and tighten any loose connections. See Steering Gear Adjustment.
2. Improper tire inflation. Check and correct.
3. Spindle bearings dry. Grease spindles. See Lubricating the Tractor.

Troubleshooting & Repair

Drive belt does not stop when clutch/brake pedal depressed.

1. Belt stops or belt tension out of adjustment. See Tractor Drive Belt in Belt Replacement section.

TROUBLESHOOTING THE MOWER

Mower will not raise.

1. Lift arms or lift link not properly attached or damaged. Attach or repair.

Mower cut is uneven.

1. Mower not leveled properly. See Mower Adjustment.
2. Tractor tires not inflated equally or properly. See Normal Care.

Mower cut is rough looking.

1. Engine speed too slow. Set for three-fourths to full speed.
2. Ground speed too fast. Set ground speed control lever at a slower ground speed.
3. Blades dull and require sharpening. See Servicing the Mower Blades.
4. Mower drive belt slipping. Belt oily or worn. Clean or replace belt as necessary.
5. Check PTO (Electric Clutch) Adjustment. Clutch may need to be adjusted.
6. Blades not properly fastened to arbors. See Servicing the Mower Blades.

Engine stalls easily with mower engaged.

1. Engine speed too slow. Set for 3/4 to full throttle.
2. Ground speed too fast.
3. Carburetor not adjusted properly.
4. Cutting height set too low when mowing tall grass. Cut tall grass at maximum cutting height during first pass.
5. Discharge chute jamming with cut grass. Cut grass with discharge pointing toward previously cut area.

Excessive mower vibration.

1. Blade mounting screws are loose. Tighten to 50-70 ft.lbs. (68-76 N.m.).
2. Mower blades, arbors, or pulleys are bent. Check and replace as necessary.
3. Mower blades are out of balance. Remove, sharpen and balance blades. See Servicing the Mower Blades.

4. Belt installed incorrectly. See Belt Replacement.

Excessive belt breakage.

1. Belt tension too tight. Adjust belt tension.
2. Bent or rough pulleys. Repair or replace.
3. Using incorrect belt. See your dealer.

Mower drive belt slips or fails to drive.

1. Idler pulley spring broken or not properly attached. See your dealer.
2. Belt stops out of adjustment. Check.
3. Mower drive belt broken. Replace.

CHECKING THE BATTERY

The voltmeter can be used to determine condition of battery. When engine is off, the voltmeter shows battery voltage, which should be 12 volts. When engine is running, the voltmeter shows voltage of charging circuit which normally is 13 to 14 volts.

A dead battery or one too weak to start the engine may not mean the battery needs to be replaced. It may, as an example, mean that the alternator is not charging the battery properly. If there is any doubt about the cause of the problem, see your dealer. If you need to replace the battery, follow the steps under Cleaning the Battery & Cables in the Normal Care Section.

CHARGING A COMPLETELY DISCHARGED BATTERY

WARNING

Do not attempt to charge a frozen battery. Allow the battery to warm to 60° F (15.5° C) before placing on charge.

1. Be aware of all the safety precautions you should observe during the charging operation. If you are unfamiliar with the use of a battery charger and hydrometer, have the battery serviced by your dealer.
2. Add water sufficient to cover the plate (fill to the proper level near the end of the charge). If the battery is extremely cold, allow it to warm before adding water because the water level will rise as it warms. Also, an extremely cold battery will not accept a normal charge until it becomes warm.
3. Always unplug or turn the charger off before attaching or removing the clamp connections.

WARNING

Keep open flames and sparks away from the battery; the gasses coming from it are highly explosive. Ventilate the battery well during charging.

- Carefully attach the clamps to the battery in proper polarity (usually red to [+] positive and black to [-] negative).
- While charging, periodically measure the temperature of the electrolyte. If the temperature exceeds 125° F (51.6° C), or if violent gassing or spewing of electrolyte occurs, the charging rate must be reduced or temporarily halted to prevent battery damage.
- Charge the battery until fully charged (i.e. until the specific gravity of the electrolyte is 1.250 or higher and the electrolyte temperature is at least 60° F). The best method of making certain a battery is fully charged, but not over charged, is to measure the specific gravity of a cell once per hour. The battery is fully charged when the cells are gassing freely at low charging rate and less than 0.003 change in specific gravity occurs over a three hour period.
- Wear safety glasses and shield eyes and face from batteries at all times. Be sure vent caps are tight. Place damp cloth over vent caps on both batteries.
- Connect positive (+) cable to positive post of discharged battery (wired to starter or solenoid).
- Connect the other end of same cable to same post marked positive (+) on booster battery.
- Connect the second cable negative (-) to other post of booster battery.
- Make final connection on engine block of stalled vehicle away from battery. Do not lean over batteries.
- Start the engine of the vehicle with the booster battery. Wait a few minutes, then attempt to start the engine of the vehicle with the discharged battery.
- If the vehicle does not start after cranking for thirty seconds, STOP PROCEDURE. More than thirty seconds seldom starts the engine unless some mechanical adjustment is made.
- After starting, allow the engine to return to idle speed. Remove the cable connection at the engine or frame. Then remove the other end of the same cable from the booster battery.
- Remove the other cable by disconnecting at the discharged battery first and then disconnect the opposite end from the booster battery.
- Discard the damp cloths that were placed over the battery vent caps.

JUMP STARTING WITH AUXILIARY (BOOSTER) BATTERY

WARNING

For your personal safety, use extreme care when jump starting. Never expose battery to open flame or electric spark – battery action generates hydrogen gas which is flammable and explosive. Do not allow battery acid to contact skin, eyes, fabrics, or painted surfaces. Batteries contain a sulfuric acid solution which can cause serious personal injury or property damage.

Jump starting is not recommended. However, if it must be done, follow these directions. Both booster and discharged batteries should be treated carefully when using jumper cables. Follow the steps below EXACTLY, being careful not to cause sparks. Refer to figure 26.

- Both batteries must be of the same voltage (6, 12, etc.).
- Position the vehicle with the booster battery adjacent to the vehicle with the discharged battery so that booster cables can be connected easily to the batteries in both vehicles. Make certain vehicles do not touch each other.

WARNING

To avoid engine damage, do not disconnect battery while engine is running. Be sure terminal connections are tight before starting.

WARNING

Any procedure other than the preceding could result in: (1) personal injury caused by electrolyte squirting out the battery vents, (2) personal injury or property damage due to battery explosion, (3) damage to the charging system of the booster vehicle or of the immobilized vehicle.

Do not attempt to jump start a vehicle having a frozen battery because the battery may rupture or explode. If a frozen battery is suspected, examine all fill vents on the battery. If ice can be seen or if the electrolyte fluid cannot be seen, do not attempt to start with jumper cables as long as the battery remains frozen.

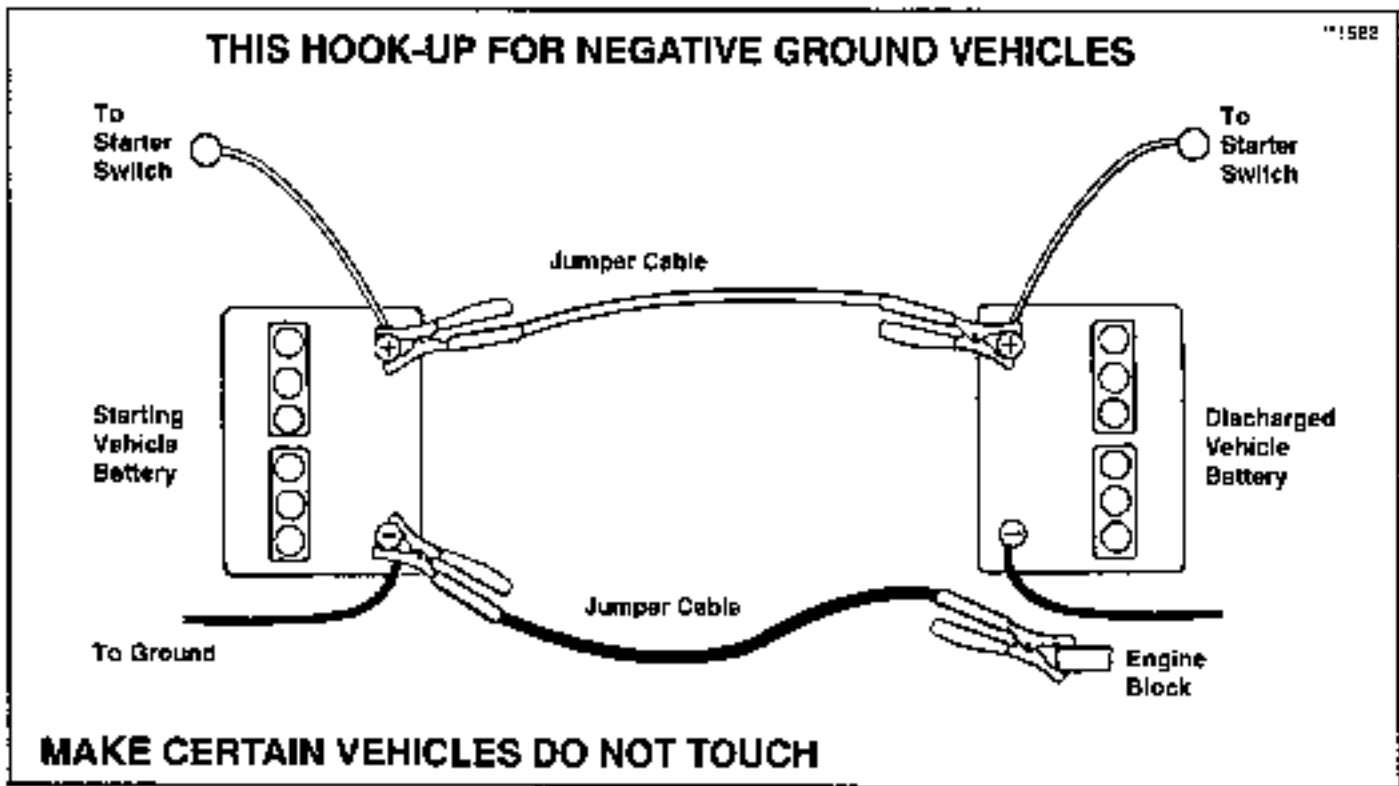

Figure 26. Battery Jump Starting Diagram

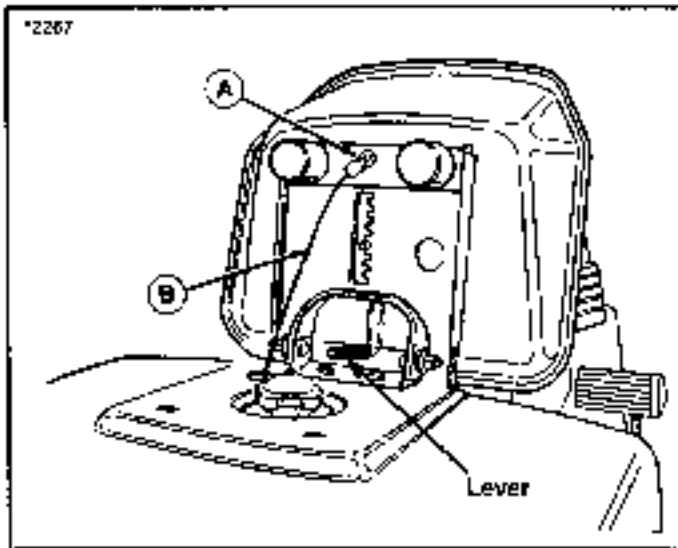

Figure 27. Seat Adjustment

WARNING

To avoid serious injury, perform adjustments only with engine stopped, key removed and tractor on level ground.

SEAT ADJUSTMENT

See figure 27. Use the lever to adjust the seat forward or rearward for best rider comfort.

BRAKE ADJUSTMENT - GEAR MODELS

1. Fully depress the brake pedal and lock the parking brake by pulling up on the parking brake rod (K, figure 2).
2. See figure 28. The spring should be compressed to 3-1/4". Turn the adjustment nut (A) as necessary to achieve correct spring length.

BRAKE ADJUSTMENT - HYDRO MODELS

1. Fully depress the clutch/brake pedal and lock the parking brake by pulling up on the parking brake knob (K, figure 2).
2. See figure 29. The brake rod spring should measure 3" (2-3/32" to 3-3/64") when compressed. Turn the adjustment nut to achieve correct spring length.

PTO (ELECTRIC CLUTCH) ADJUSTMENT

1. Make sure engine is off and key removed.
2. Use a 0.010 - 0.012 feeler gauge to check the PTO at three places. See figure 30. Insert the gauge between the drive spring rivets. There should be a slight resistance as gauge is moved in and out of slot.

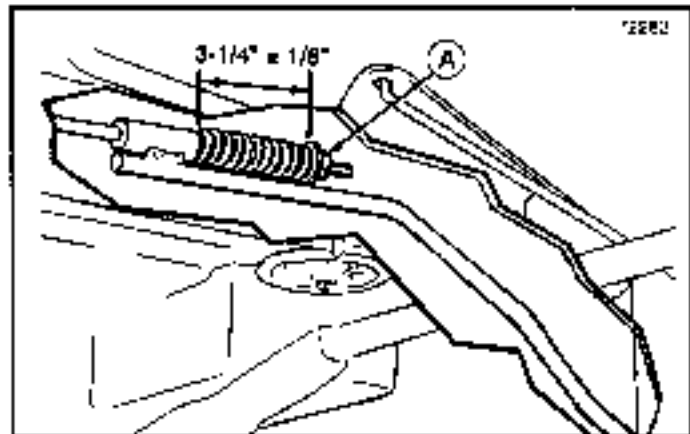

Figure 28. Brake Adjustment - Gear Models

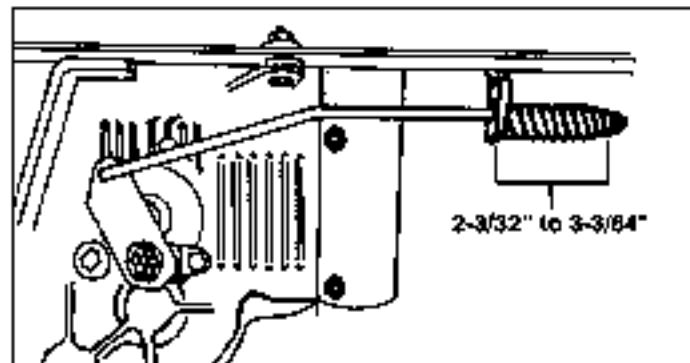

Figure 29. Brake Adjustment - Hydro Models

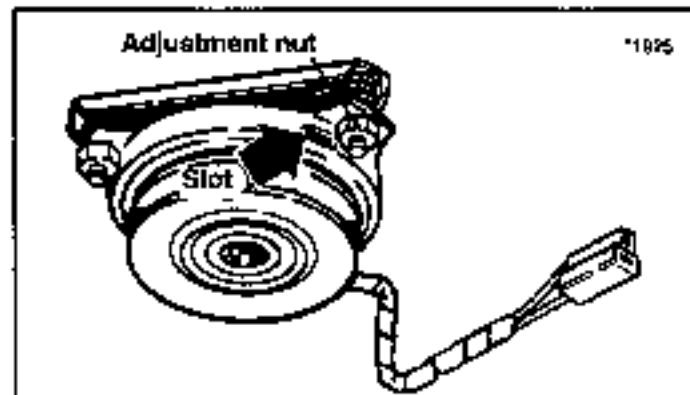

Figure 30. PTO Clutch Adjustment

Adjustments

If adjustment is required, proceed to step 3.

- Loosen or tighten one of the nuts as required to obtain the specified clearance. Loosen the nuts to increase the gap, tighten the nuts to decrease the gap.
- After adjusting one nut, check the other two with a feeler gauge. Adjustment at one location will change the measurement at the other two locations. Make sure all three locations have proper adjustment.
- Perform Blade Brake Adjustment. See procedure on page 29.

STEERING GEAR ADJUSTMENT

If there is excessive slack in the steering system, the steering gear backlash can be removed.

- See figure 31. Loosen the two capscrews and adjust the bracket so the gear teeth are closely meshed.
- Tighten nuts after adjustment.

STEERING WHEEL ADJUSTMENT

- Pull down on the rubber boot to expose the two holes in the steering shaft (M, figure 2).
- Use a suitable drift to remove the roll pin at the base of the steering wheel.
- Align the hole in the steering wheel with the appropriate steering shaft hole and install the roll pin.

NOTE: Steering wheel is factory installed with the roll pin in the bottom hole.

MOWER ADJUSTMENT

WARNING

Before checking mower, shut off PTO and engine. Allow all moving parts to stop. Remove ignition key, then disconnect the spark plug wire and fasten it away from the spark plug.

Leveling The Mower

If the cut is uneven, the mower may need leveling. Unequal or improper tire pressure may also cause an uneven cut. Make sure tire pressure is correct as specified in Checking Tire Pressure.

- With the mower installed, place the tractor on a smooth, level surface such as a concrete floor. Turn the front wheels straight forward.
- Check for bent blades and replace if necessary.
- Place the mower in mid-cut position. Arrange the outside mower blades so that they are pointing from side-to-side.

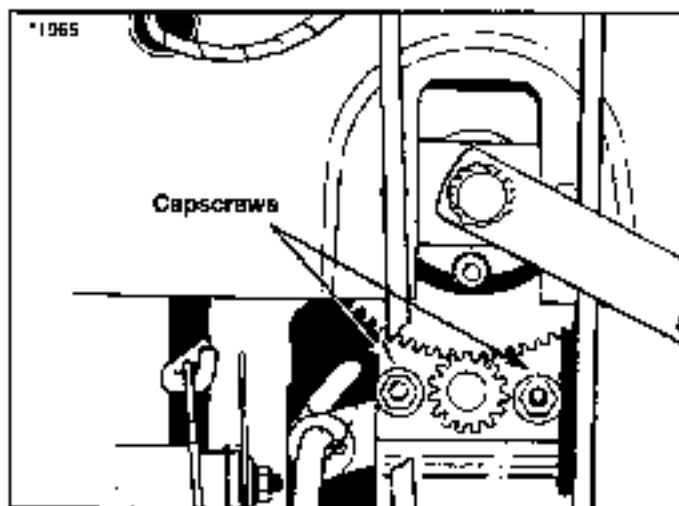

Figure 31. Steering Gear Adjustment

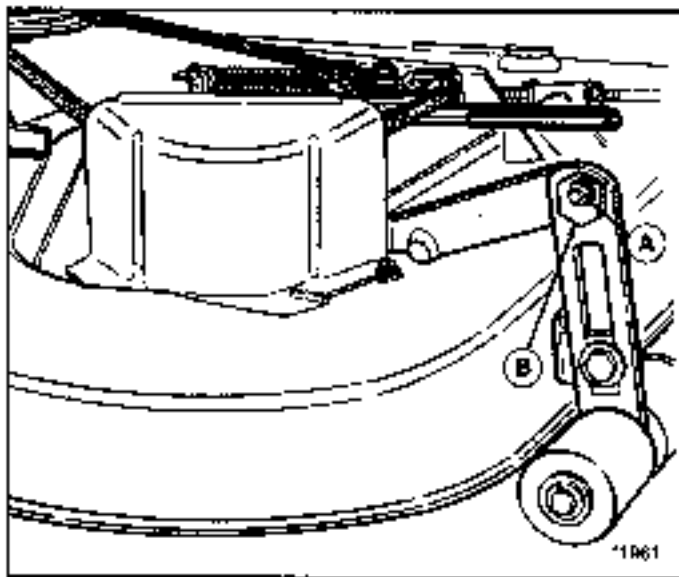

Figure 32. Leveling The Mower Side-to-Side
A. Outside Nut B. Eccentric Nut

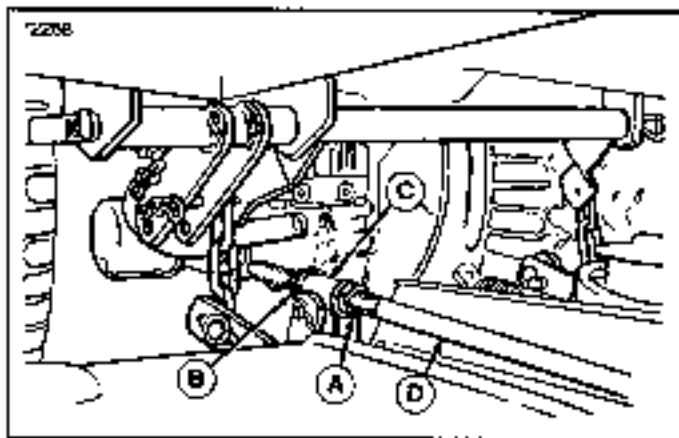

Figure 33. Leveling The Mower Front-To-Back
A. Front Nut C. Mower Bracket
B. Rear Nut D. Adjustment Rod

4. Measure the distance between the outside tips of each blade and the ground. If there is more than 1/8" (3mm) difference between the measurements on each side, proceed to step 5. If the difference is 1/8" (3mm) or less, proceed to step 6.
5. See figure 32. Loosen the outside nut (A). Turn the eccentric nut (B) to raise or lower left-hand side of mower. When mower is level, hold the eccentric nut while tightening the outside nut.

NOTE: When using a turbo collection system, raise the discharge side of the mower approximately 1/4" to compensate for turbo assembly weight. Check the level of the cut grass and adjust the 1/4" measurement as necessary for a smooth, even cut.

6. Arrange the blades so they face front-to-back.
7. Measure the distance from the ground to the front tip of the center blade, and from the ground to rear tips of left-hand and right-hand blades.
Front tip of the center blade should be 1/4" higher than rear tips of left-hand and right-hand blades. If not, proceed with steps 8 - 10.

8. See figure 33. To raise front of mower deck, loosen front nut (A) and turn rear nut (B) against bracket (C).
9. To lower front of mower deck, loosen rear nut (B) and bracket (C) will move backwards to lengthen rod.
10. Re-check measurement before tightening front nut (A) against bracket.

Blade Brake Adjustment

Mower blades and mower drive belt should come to a complete stop within five seconds after electric PTO switch is turned off.

1. With tractor in neutral, PTO disengaged and operator in seat, start the tractor engine.
2. Look over the left-hand footrest at the mower drive belt. Engage the PTO and wait several seconds. Disengage the PTO and check the amount of time it takes for the mower drive belt to stop.
3. If mower drive belt does not stop within five seconds, perform the steps described under PTO (Electric Clutch) Adjustment. Repeat steps 1 and 2. If belt still does not stop within 5 seconds, see your dealer.

Belt Replacement

CAUTION

To avoid damaging belts, do not pry belts over pulleys.

TRACTOR DRIVE BELT

1. Park the tractor on a smooth, level surface such as a concrete floor. Disengage the PTO, turn off the engine and lock the parking brake. Remove the key.
On gear models, depress (or clamp) the clutch pedal fully forward to relieve belt tension.
On hydro models, lock the parking brake to relieve belt tension.
2. Remove the mower as described under Mower Removal in the Operation section.
3. See figure 34. Loosen capscrews (A). Slip belt from between front V-pulley (B) and belt stop and from between rear idler pulley (C) and belt stop.
4. See figure 35. To remove belt from engine pulley, the PTO (electric clutch) must be removed and the belt slid over the top of the pulley. Disconnect the PTO wire. Remove the capscrew (A) along with the hex washer and lockwasher securing the PTO to the engine crankshaft. Slide belt over the top of the engine pulley.
5. See figure 35. Install new belt over engine pulley before re-installing the electric clutch. Install hex washer, lockwasher and capscrew (A). Lubricate weld tab on underside of tractor (D). Make sure tab is aligned with hole in top of electric clutch, then tighten capscrew to 45-50 ft. lbs. (61-68 N.m.).

NOTE: Check capscrew torque after 1 hour of operation.

6. See figure 35. On left-hand side of tractor, remove nut from capscrew (E) securing drag link (B) to steering arm (C). Drop old belt below drag link. Route new belt above drag link before re-installing nut on drag link, then tighten nut.
7. See figure 36. Slip belt from transaxle pulley and fixed idler pulley (hydro models). Remove belt.

NOTE: On hydro models, spin the transaxle cooling fan counterclockwise and slip belt through the blade.

8. Install new belt to the transaxle pulley and fixed idler pulley (hydro models).
9. Install new belt to idler pulleys as shown in figure 36.
10. Install new belt to the idler pulleys as shown in figure 36. Make sure belt is properly routed on flat and V sides. Tighten capscrews (A, figure 32) securing pulleys. Adjust belt stops for 1/8" clearance from pulleys.
12. See figure 36. Check belt routing around engine pulley, idler pulleys, and transaxle pulley. Check that the electric clutch, drag link and idler pulley spring are all correctly installed.

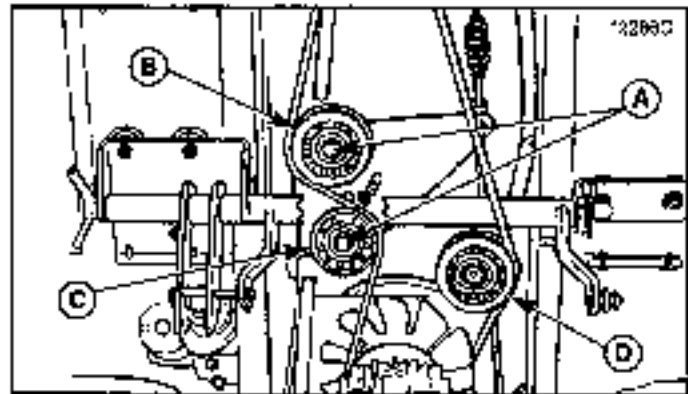

Figure 34. Drive Belt Idler Pulley

- | | |
|--------------|-----------------------|
| A. Capscrews | C. Idler Pulley |
| B. V-Pulley | D. Fixed Idler Pulley |

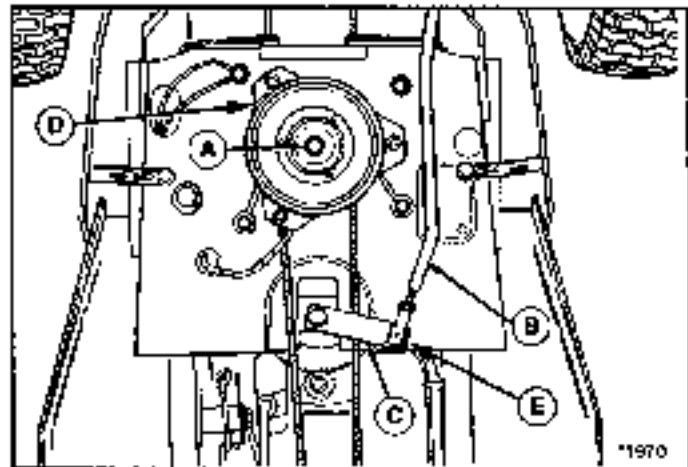

Figure 35. Drive Belt PTO Pulley

- | | |
|------------------|----------------------|
| A. Capscrew, PTO | D. Weld Tab Location |
| B. Drag Link | E. Capscrew |
| C. Steering Arm | |

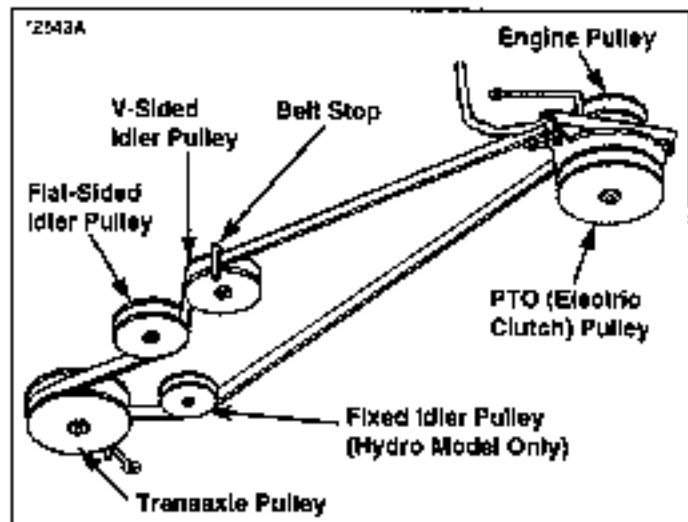

Figure 36. Tractor Drive Belt Routing

13. Start tractor engine and check operation of belt by placing ground speed lever in gear and engaging/disengaging the clutch/brake pedal.

MOWER DECK-TO-PTO BELT

NOTE: It is not necessary to remove the mower to install a new belt. However, for easier access mower can be removed. See Mower Removal in the Operation section.

1. Park the tractor on a smooth, level surface such as a concrete floor. Disengage the PTO, turn off the engine and lock the parking brake. Remove the key.
2. If mower is not removed, place the mower in the lowest cutting position.
3. Push the idler arm (A, figure 37) away from you to relieve belt tension. Drop belt from the PTO (electric clutch) pulley.
4. Loosen nut and lockwasher securing bracket belt stop (C, figure 38) on idler pulley. Remove three cap-screws securing left-hand arbor cover (D, figure 38).
5. Remove old belt and replace with new belt. Make sure V-side of belt runs in arbor pulley grooves.
6. Position the bracket belt stop (C, figure 37) up against arm (A) so that there is a 1/8" gap between pulley and belt stop.
8. Install mower on tractor if it was removed. See Operation section, Mower Installation. Install belt to PTO pulley.
9. Run the mower under no-load condition for about 5 minutes. Check blade brake adjustment after 1 hour of operation.

MOWER ARBOR BELT

1. Park the tractor on a smooth, level surface such as a concrete floor. Disengage the PTO, turn off the engine and lock the parking brake. Remove the key.
2. Remove the mower from the tractor. See Mower Removal in the Operation section.
3. See figure 3B7. Remove the two capscrews securing upstop (A) and remove the upstop.
4. Remove four additional capscrews securing right-hand arbor cover (B). Remove three capscrews securing left-hand arbor cover (D).
5. Using a vise-grip or pliers, remove idler pulley spring (C) from slot in deck.
6. Loosen capscrew (E) securing idler pulley to bracket. Belt can be slipped between pulley and idler bracket hub.

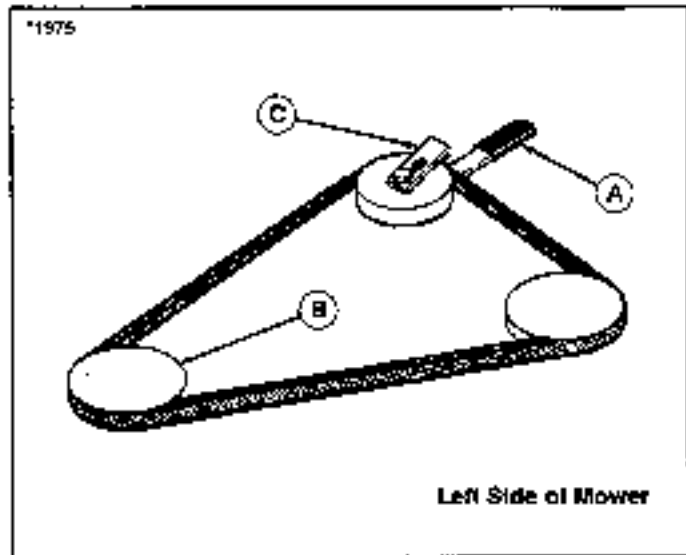

Figure 37. Mower Belt Routing - 44" Mower Deck
A. Idler Pulley Arm C. Bracket Belt Stop
B. PTO Pulley

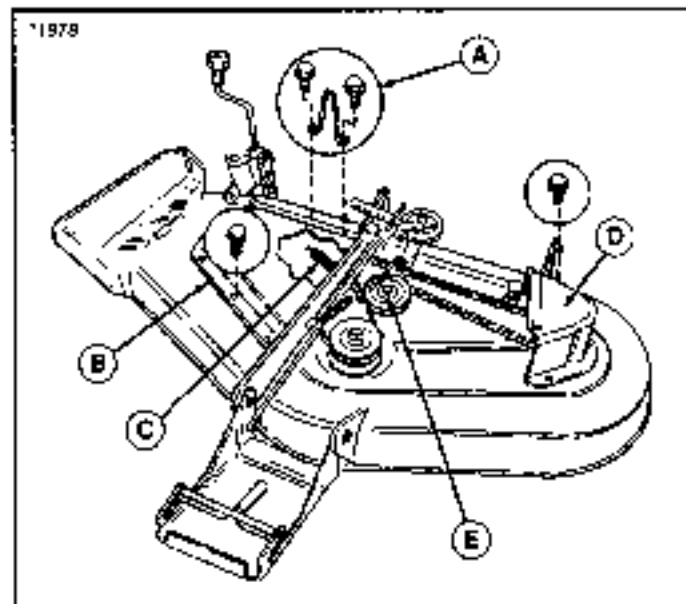

Figure 38. Mower Deck
A. Upstop
B. Right-hand Arbor Cover
C. Spring
D. Left-hand Arbor Cover
E. Capscrew

7. Install new belt as shown in figure 39. Make sure that V-side of belt runs in arbor pulley grooves and flat side of belt runs against idler pulley.
8. Install spring (C, figure 38) to slot in mower deck. Tighten capscrew securing idler pulley.

Belt Replacement

9. Install left and right arbor covers and upstop using original hardware.
10. Install mower to tractor.

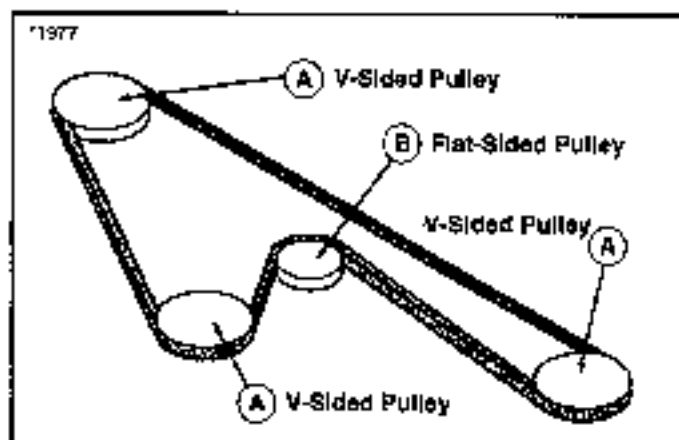

Figure 3B. Mower Arbor Belt Routing
A. Arbor Drive Pulley (V-sided)
B. Idler Pulley (Flat-sided)

NOTE: Specifications are correct at time of printing and are subject to change without notice.

ENGINE

16 HP Briggs & Stratton

Make	Briggs & Stratton
Model	Vanguard V-Twin
Horsepower	16 HP @ 3600 rpm
Cylinders	2
Bore	2.62 in. (66 mm)
Stroke	2.60 in. (66 mm)
Displacement	29.3 Cu. In. (480 cc)
Construction	Overhead Valve, Cast Iron Sleeves, Aluminum Crankcase
Electrical System	12 Volt, 16 Amp Alternator Regulated Battery; 340 Cold Cranking Amps, 41 min. Reserve Capacity, Industrial Rated Starter Motor
Ignition	Magneton Electronic Ignition
Air Cleaner	Ducted Paper Cartridge and Foam Pre-cleaner; large 325 sq. in. Air Filtering System
Lubrication	Full Pressure Lube w/ Oil Filter
Oil Capacity	3.5 Pints w/Filter (1.6 L)
Fuel Tank	Material: Non-Corrosive Polyethylene Fuel Tank Gauge Built into Filter Cap Capacity: 4 Gallons (15.1 L)
Muffler	Quiet Compact, Low Back Pressure

18 HP Briggs & Stratton

Make	Briggs & Stratton
Model	Vanguard V-Twin
Horsepower	18 HP @ 3600 rpm
Cylinders	2
Bore	3.00 in. (77 mm)
Stroke	2.64 in. (67 mm)
Displacement	38 Cu. In. (624 cc)
Construction	Cast Iron Sleeves, Aluminum Crankcase
Electrical System	12 Volt, 15 Amp Alternator Regulated Battery; 340 Cold Cranking Amps, 41 min. Reserve Capacity, Industrial Rated Starter Motor
Ignition	Magneton Electronic Ignition
Air Cleaner	Replaceable Paper with Oiled Foam Pre-cleaner
Lubrication	Full Pressure Lube with Oil Filter
Oil Capacity	2 Quarts (1.9 L)
Fuel Tank	Material: Non-Corrosive Polyethylene Fuel Tank Gauge Built into Filter Cap Capacity: 3 Gallons (11.1 L)
Muffler	Quiet Compact, Low Back Pressure

TRANSMISSION

Gear Models

Type	Spur Gear
Material	Gear: Heat Treated Shaft: Hardened and Ground Bearings: Needle Roller, Sealed Ball and Bushings
Lubrication	7.7 Pints (3.7 L) SAE #0W-30 Premium Grade Engine Oil
Speeds	Six Forward, One Reverse
Speeds @ 3400 RPM	1st: 0.6 MPH (1.0 km/h) 2nd: 1.1 MPH (1.8 km/h) 3rd: 1.8 MPH (2.9 km/h) 4th: 2.7 MPH (4.3 km/h) 5th: 3.9 MPH (6.3 km/h) 6th: 5.5 MPH (8.8 km/h) Reverse: 2.2 MPH (3.5 km/h)
Differential	Bevel Gear Type

Hydro Models

Type	Hydrostatic
Pump	Variable Displacement Piston
Motor	Fixed Displacement Piston
Hydraulic Fluid	
- Tuff Torq K215A	5.8 Pints SAE 10W-30 Premium Grade Engine Oil
- Hydro Gear 3010L	76 oz. SAE 13W-40 Premium Grade Engine Oil
Control	Single Lever w/Neutral Detent, Release Lever for Manual Tractor Movement, Continuously Variable, Forward & Reverse, without Braking
Speeds @ 3400 RPM	
- Tuff Torq K215A	Forward: 0-6 MPH (0-9.7 km/h) Reverse: 0-2.6 MPH (0-3.9 km/h)
- Hydro Gear 3010L	Forward: 0-6.6 MPH (0-10.1 km/h) Reverse: 0-3.1 MPH (0-5 km/h)

Differential	
- Tuff Torq K215A	Bevel Gear Type
- Hydro Gear 3010L	Heavy Duty Spur Gear

CONTROLS

Steering	Full Circle Steering Wheel System Gear and Sector
Hydro Clutch/ Brake Pedal	Location Right Front Combination Clutch/Brake/Parking Brake Pedal Standard Equipment

Specifications

Gear Brake Pedal	Location Right Front
Gear Clutch Pedal	Location Left Front
Location	-Electric Mower Lift Lever; switch on dash -Manual Mower Lift Lever; tractor right side -PTO Clutch Electric, Dash Mounted -Ground Speed Lever Dash Mounted -Ignition Key Switch on dash panel -Throttle Lever and Choke Lever on dash panel -Light Switch on dash panel -Separate Indicator Lights for Safety -Interlock Switch Operator Present -Transmission Neutral, PTO Disengaged, Clutch/Brake Pedal Depressed -Low Oil Pressure Warning Light

CHASSIS

Frame	Heavy Gauge Steel Channel Power Take-Off Point Front Engine Mounting Above Front Axle Pivot Point Location Front Axle
Rear Wheels	Tire Size 23 x 10.5-12 Turf Type Pneumatic Inflation Pressure 6-8 psi (41-55 kPa)
Front Wheels	Tire Size 16 x 6.50-8 Pneumatic Inflation Pressure 12-15 psi (82-103 kPa)
Front Axle	1-3/4" x 3" 12 Ga. Fabricated Rectangular Tube
Accessibility	Hood Tips Forward
Seat	Type Bucket, High Back, Adjustable w/ Spring Suspension Adjustable to Suit Different Size Operators
Turning Radius	Inside Rear Tire 24 in. (61 cm)

DIMENSIONS

Tractor

Overall Length	72 in. (183 cm)
Overall Width	39 in. (99.1 cm)
Height	To Top of Steering Wheel 42.5 in. (108 cm) To Top of Engine Cover 36 in. (91.4 cm)
Wheel Base	51.5 in. (131 cm)
Weight (approx.) without mower	Net: 670 lbs. (304.5 kg) Shipping: 815 lbs. (370 kg)

Mower - 44"

Effective Cutting Width	44 in. (111.8 cm)
Overall Width with Deflector	58 in. (147.2 cm)
Weight	115 lbs. (52 kg)
Variable Cutting Ht.	1-3.6 in. (2.5 to 91 cm)
Blade Arrangement	Three Staggered Blades
Mower Drive	V-Belt From Tractor PTO Pulley
Spindle Bearings	Lubricated and Sealed Ball Bearings

Mower - 50"

Effective Cutting Width	50 in. (127 cm)
Overall Width with Deflector	62 in. (157.5 cm)
Weight	135 lbs. (61.4 kg)
Variable Cutting Ht.	1-3.6 in. (2.5 to 91 cm)
Blade Arrangement	Three Staggered Blades
Mower Drive	V-Belt From Tractor PTO Pulley
Spindle Bearings	Lubricated and Sealed Ball Bearings

COMMON REPLACEMENT PARTS

Listed below are the more common replacement parts. Only genuine factory replacement parts will assure optimum performance and safety. Do not attempt repairs or maintenance unless proper procedures and safety precautions are followed. For assistance in any area, see your dealer.

QTY.	DESCRIPTION	PART NO.
	Mower Blades	
3	- 44" Standard Lift	1704100
3	- 44" High Lift (Optional)	1704056
3	- 50" Standard Lift	1708229
3	- 50" High Lift (Optional)	1708094
	Mower Belts	
1	- 44" Mower Drive	1601672
1	- 44" Arbor Drive	1607813
1	- 50" Mower Drive	1707740
1	- 50" Arbor Drive	1703836
	Tractor Drive Belt	
1	- Gear (Tuff Torq Model K210A)	1707381
1	- Gear (Peerless)	1714814
1	- Hydro (Tuff Torq Model K215A)	170164
1	- Hydro (Hydro Gear Model 216-3010L)	1707381
1	Safety Clip - Mower Lift	178012
1	Key, Ignition	1714054
2	Interlock Switch, Neutral	1701521
1	Interlock Switch, Seat	1704379
1	Battery	1685215
1	Solenoid	1685290
1	Switch, PTO (Electric Clutch)	1713487
1	Headlamp Bulb	1677371
1	Oil Filler (Hydro Pump)	1707873

MAINTENANCE ITEMS

DESCRIPTION	PART NO.
• Simplicity Engine Oils	
Case of 12 qts. (Your dealer has 1 qt. cans)	
-SAE 5W-30 SF/CD (Cold Weather 30" & under)	1685576
-SAE 30 3G/CC (Warm weather 32" & up)	1685659
• Touch-Up Paint	
Deep Orange Spray Paint, 13 oz. Can	1685611
Deep Orange Paint, 1 qt.	1685612
Black Spray Paint, 13 oz. Can	1685639
Red Spray Paint, 13 oz. Can	1685722
Metallic Gray, 13 oz. Can (Wheels)	1685718
• Touch-Up Daubers	
Deep Orange 1/2 oz. w/Brush Cap	1685615
• Grease Gun Kit w/8 oz. Grease Tube	1685510
Replacement 8 oz. Grease Tube for above	103077
• Tire Sealant-Stops Tire Leaks. Prevents Flats.	
11 oz. Tube	1685523
• Gas Can-No Tip Design. Durable Polyethylene.	
1 gallon	1685587
2-1/2 gallon	1685555
5-1/4 gallon	1685558
• Cleaner, Polish, Sealant & Protectant	
8 oz. Bottle	1685696
• Degreaser/Degreaser	
32 oz. Bottle w/Trigger Spray	1685619
1 gallon	1685621

**USE ONLY GENUINE
FACTORY REPLACEMENT PARTS**
Available Through Your Local
Authorized Dealer

Parts & Accessories

OPTIONAL ACCESSORIES

See your dealer to purchase these items.

Turbo Clean Sweep Twin Catcher

Clean Sweep Twin Catcher

Turbo Quad Bagger™

Front Counterweights

Dump Cart

Rear Wheel Weights/Weight/Tote
Box

40" & 42" Snowthrower

42" Dozer Blade

Hubcaps

36" Tiller

Tire Chains

Snow Cab

Grass Mulcher & Leaf Shredder Kit



TECHNICAL MANUAL AVAILABILITY

Manuals are fully illustrated. All of the assemblies are shown in exploded views which show the relationship of the parts and how they go together. Important assembly notes and special torque values are included in the illustrations. Standard hardware and torque specification charts are also included.

For the manuals applicable for your model, contact the Customer Publications Department at 414-264-8519. Have the following information available when phoning in your request.

Model: _____

Mfg. No.: _____

Your Name: _____

Address: _____

City, State, Zip: _____

Visa/Mastercard No.: _____

Card Expiration Date: _____



INTERNATIONAL SYMBOLS



Fast



Slow



Operator Present
Switch (Seat)



PTO Engaged

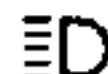

Lights



Oil Pressure



Forward



Reverse



Parking Brake



Clutch



Engine Running





500 N. Spring Street, P.O. Box 997
Port Washington, WI 53074-0997 USA

Form Nos. 1715803-00
1714300-03

Rev. 6/95
© Copyright 1996 Simplicity Manufacturing, Inc.
All Rights Reserved. Printed in USA.
TP 340-E00E-03-LL-A