



福田零部件图册

(FT254A-CK1)

福田雷沃重工国际贸易有限公司

目录 CONTENTS

序号 No.	代码 Code	名称 Description		页次 Page
1	FT250.11B.001	11-空气滤清系总成	11-AIR CLEANER ASSEMBLY	1
2	FT250.13.001	13-冷却系总成	13-COOLING SYSTEM ASSEMBLY	3
3	FT250.20B.001-1	20.1-发动机操纵机构总成-1	20.1ENGINE CONTROL MECHANISM ASSEMBLY-1	5
4	FT250.20B.001-2	20.2-发动机操纵机构总成-2	20.2ENGINE CONTROL MECHANISM ASSEMBLY-2	7
5	FT250.21B.001-1	21.1-离合器总成-1	CLUTCH ASSEMBLY-1	11
6	FT250.21B.001-2	21.2-离合器总成-2	CLUTCH ASSEMBLY-2	15
7	FT250.22B.001	22-排气系总成	22-EXHAUST SYSTEM ASSEMBLY	19
8	FT250.24.001	24-蓄电池安装总成	24-BATTERY INSTALLATION ASSEMBLY	21
9	FT254.32.001	32-前驱动轮总成	32-FRONT DRIVING WHEEL ASSEMBLY	23
10	FT250.34.001	34-驱动轮总成	34-DRIVING WHEEL ASSEMBLY	25
11	FT250.35.001	35-牵引装置装配总成	35-TRACTION EQUIPMENT MOUNTING ASSEMBLY	27
12	FT250.36B.001-1	36.1-离合器壳总成-1	CLUTCH HOUSING ASSEMBLY -1	29
13	FT250.36B.001-2	36.2-离合器壳总成-2	CLUTCH HOUSING ASSEMBLY -2	33
14	FT250.37C.001-1	37.1-传动箱总成-1	TRANSMISSION CASE ASSEMBLY-1	35
15	FT250.37C.001-2	37.2-传动箱总成-2	TRANSMISSION CASE ASSEMBLY-2	39
16	FT250.37C.001-3	37.3-传动箱总成-3	TRANSMISSION CASE ASSEMBLY-3	43
17	FT250.37C.001-4	37.4-传动箱总成-4	TRANSMISSION CASE ASSEMBLY-4	47
18	FT250.37C.001-5	37.5-传动箱总成-5	TRANSMISSION CASE ASSEMBLY-5	49
19	FT250.37C.001-6	37.6-传动箱总成-6	TRANSMISSION CASE ASSEMBLY-6	51
20	FT250.37C.001-7.1	37.7.1-传动箱总成-7.1	TRANSMISSION CASE ASSEMBLY-7.1	53
21	FT250.37C.001-7.2	37.7.2-传动箱总成-7.2	TRANSMISSION CASE ASSEMBLY-7.2	55
22	FT250.37C.001-8	37.8-传动箱总成-8	TRANSMISSION CASE ASSEMBLY-8	59
23	FT254.40.001-1	40.1-全液压转向总成-1	40FULL HYDRAULIC STEERING ASSEMBLY-1	63
24	FT254.40.001-2	40.2-全液压转向总成-2	40FULL HYDRAULIC STEERING ASSEMBLY-2	65
25	FT250.41A.001-1	41.1-动力输出总成-1	POWER TAKE-OFF ASSEMBLY-1	67

目录 CONTENTS

序号 No.	代码 Code	名称 Description		页次 Page
26	FT250.41A.001-2	41.2-动力输出总成-2	POWER TAKE-OFF ASSEMBLY-2	69
27	FT254.42.001-1	42.1-分动箱总成-1	TRANSFER CASE ASSEMBLY-1	73
28	FT254.42.001-2	42.2-分动箱总成-2	TRANSFER CASE ASSEMBLY-2	77
29	FT250.43.001-1	43-制动器及操纵机构-1		81
30	FT250.43.001-2	43-制动器及操纵机构-2		83
31	FT250.44B.001	44-座椅总成	44-SEAT ASSEMBLY	87
32	FT250.46.001a	46-安全架总成	46-SAFETY FRAME ASSEMBLY	89
33	FT250.48D.001-1	48.1-电气系统总成-1	ELECTRICAL SYSTEM ASSEMBLY-1	91
34	FT250.48D.001-2	48.2-电器系统总成-2	ELECTRICAL SYSTEM ASSEMBLY-2	95
35	FT250.49A.001	49-工具箱安装总成	49-TOOL BOX INSTALLATION ASSEMBLY	97
36	FT250.50.001	50-燃油箱总成		99
37	FT250.55.001-1	55.1-提升器总成-1	LIFTER ASSEMBLY-1	101
38	FT250.55.001-2	55.2-提升器总成-2	LIFTER ASSEMBLY-2	105
39	FT250.55.001-3	55.3-提升器总成-3	LIFTER ASSEMBLY-3	107
40	FT250.56.001-1	56.1-悬挂机构总成-1	SUSPENSION MECHANISM ASSEMBLY-1	111
41	FT250.56.001-2	56.2-悬挂机构总成-2	SUSPENSION MECHANISM ASSEMBLY-2	115
42	FT250.57.001	57-分配器总成		119
43	FT254.58.001-1	58.1-多路阀油泵油管总成-1	MULTI-WAY VALVE OIL PUMP OIL PIPE ASSEMBLY-1	123
44	FT254.58.001-2	58.2-多路阀油泵油管总成-2	MULTI-WAY VALVE OIL PUMP OIL PIPE ASSEMBLY-2	127
45	FT250.62.001ZC	62-安全带总成	62-SAFETY BELT ASSEMBLY	131
46	FT250.74.001	74-前配重总成	74-FRONT BALLAST ASSEMBLY	133
47	FT250.21B.011	离合器分总成	CLUTCH SUBASSEMBLY	135

FT250.11B.001 空气滤清系总成

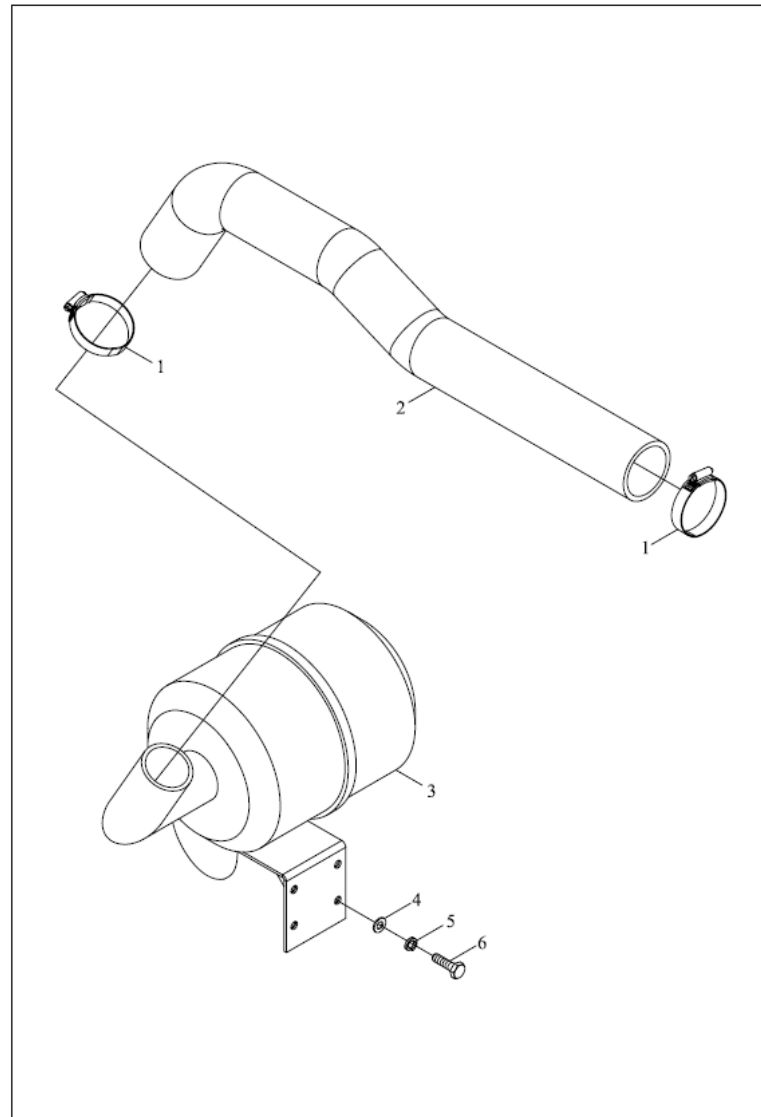

FT250.11B.001 11-空气滤清系总成 11-AIR CLEANER ASSEMBLY

标号 No.	代号 Code	名称 Description		数量 Quantity	备注 Remark
1	Q67664	B型蜗杆传动式软管环箍	B-TYPE WORM TRANSMISSION HOSE CLAMP	2	2011-11_
2	FT250.11B.101	进气管	AIR INLET PIPE	1	2011-11_
2	TE250.11B-01	进气软管	AIR INLET HOSE	1	2012-12_
3	FT250.11B.010	空滤器总成	AIR FILTER ASSEMBLY	1	2011-11_
3.1	FT250.11B.010-05	空滤芯	AIR FILTER ELEMENT	0	2011-11_
4	GBT97.1-8-A0P	平垫圈	WASHER	4	2011-11_
5	GBT93-8-A0P	垫圈	WASHER	4	2011-11_
6	GBT5783-M8X25-A2L	螺栓	BOLT	4	2011-11_

FT250.13.001 冷却系总成

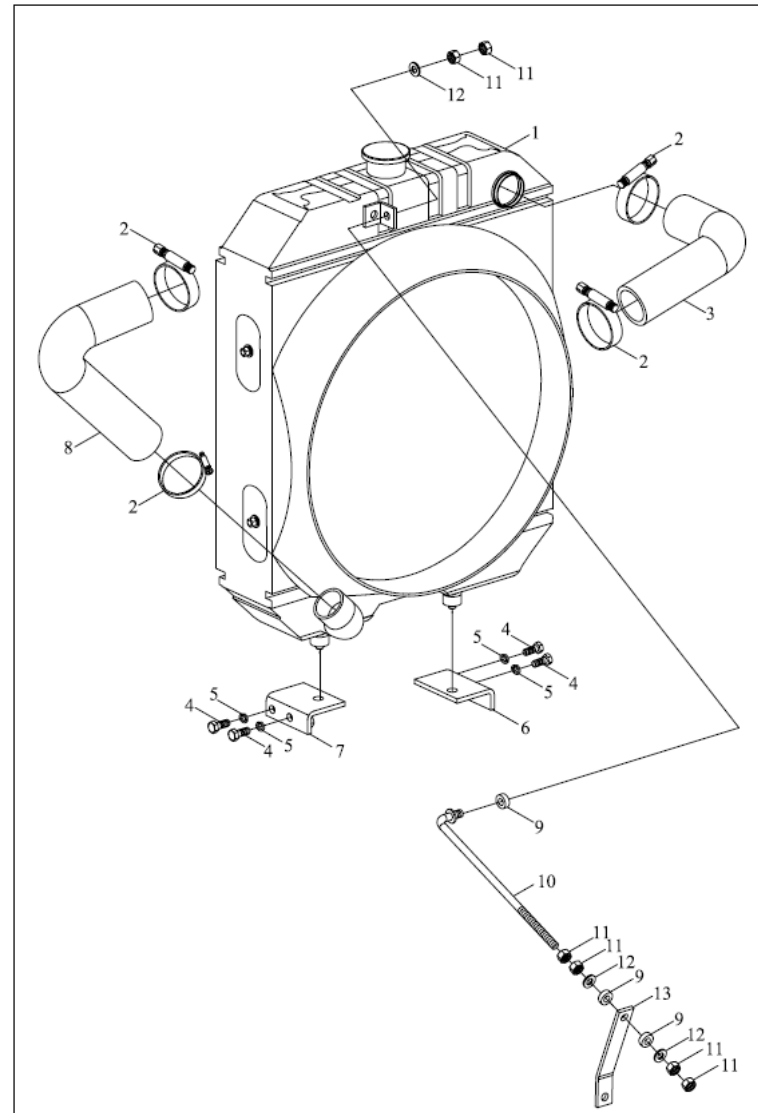

FT250.13.001 13-冷却系总成 13-COOLING SYSTEM ASSEMBLY

标号 No.	代号 Code	名称 Description		数量 Quantity	备注 Remark
1	FT250.13.010	散热器总成	RADIATER ASSEMBLY	1	2011-11_
10	FT250.13.030	散热器拉杆焊合	RADIATOR PULL ROD WELDMENT	1	2011-11_
11	GBT6172.1-M8-A2L	螺母	NUT	6	2011-11_
12	GBT97.1-8-A0P	平垫圈	WASHER	3	2011-11_
13	FT250.13.016	散热器拉杆支架合件	RADIATOR PULL ROD BRACKET UNIT	1	2011-11_
2	Q67650	B型蜗杆传动式软管环箍	B-TYPE WORM TRANSMISSION HOSE CLAMP	4	2011-11_
3	FT250.13.101	水箱进水管	WATER TANK WATER INLET HOSE	1	2011-11_
4	GBT5783-M8X30-A2L	螺栓	BOLT	4	2011-11_
5	GBT93-8-A0P	垫圈	WASHER	4	2011-11_
6	FT250.13.012	散热器右支架焊合	RADIATOR RIGHT BRACKET WELDMENT	1	2011-11_
7	FT250.13.011	散热器左支架焊合	RADIATOR LEFT BRACKET WELDMENT	1	2011-11_
8	FT250.13.102	水箱出水管	WATER TANK OUTLET HOSE	1	2011-11_
9	FT650.13.135	橡胶垫块	RUBBER PAD BLOCK	3	2011-11_

FT250.20B.001 发动机操纵机构总成-1

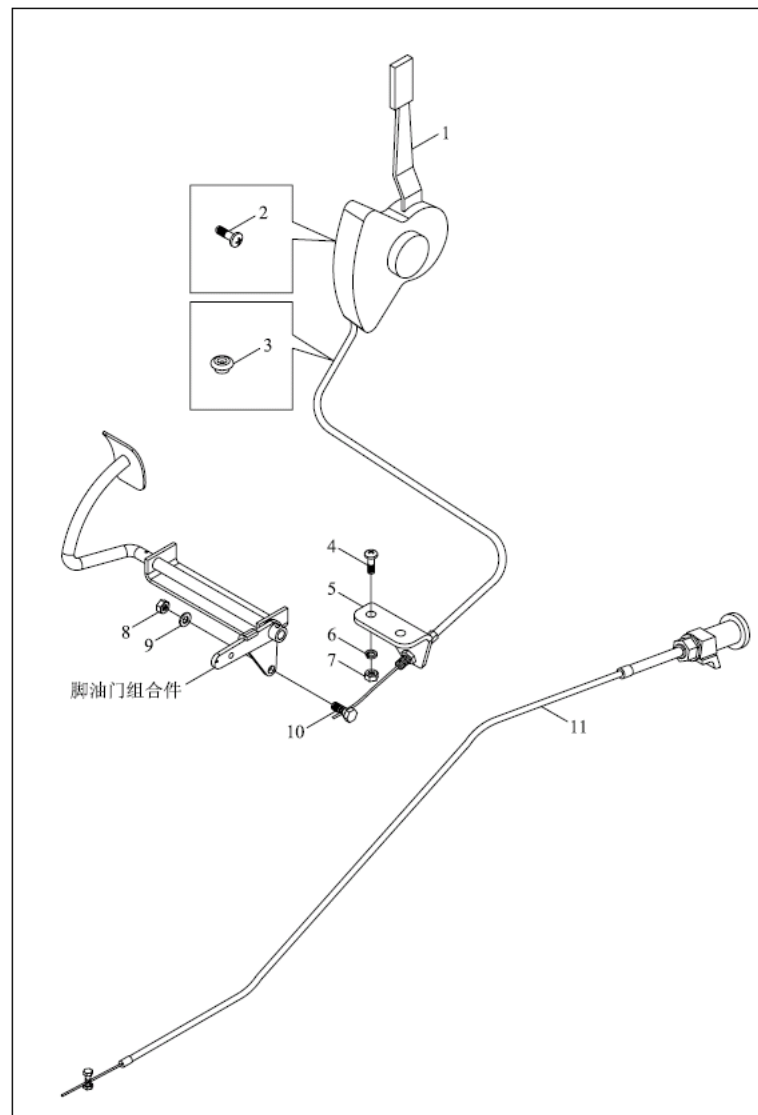

FT250.20B.001-1 20.1-发动机操纵机构总成-1 20.1ENGINE CONTROL MECHANISM ASSEMBLY-1

标号 No.	代号 Code	名称 Description		数量 Quantity	备注 Remark
1	TE250.20.4	手油门总成	HANDLE THROTTLE ASSEMBLY	1	2004-01_
1	TE250.201.1	手油门总成	HANDLE THROTTLE ASSEMBLY	1	2008-01_
1	TE250.201.1	手油门总成	HANDLE THROTTLE ASSEMBLY	1	2008-01_
10	FT650.20.133	紧固螺钉	LOCKING SCREW	1	2011-11_
11	FT250.20B.017	熄火拉线总成	EXTINGUISH WIRE ASSEMBLY	1	2011-11_
2	GBT68-M8X20-A0P	开槽沉头螺钉	SCREW	3	2004-01_
3	TD800.484B-03	过线胶圈	RUBBER RING	1	2004-01_
3	TE324.20A-01	过线胶圈	RUBBER RING	1	2008-12_
4	GBT818-M8X20-A2L	十字槽盘头螺钉	SCREW	2	2011-11_
5	FT250.20.104	手油门拉线支架	PULL WIRE BRACKET OF HAND THROTTLE	1	2011-11_
6	GBT93-8-A0P	垫圈	WASHER	2	2011-11_
7	GBT6172.1-M8-A2L	螺母	NUT	2	2011-11_
8	GBT6170-M8-A2L	螺母	NUT	1	2011-11_
9	GBT97.1-8-A0P	平垫圈	WASHER	1	2011-11_

FT250.20B.001 发动机操纵机构总成-2

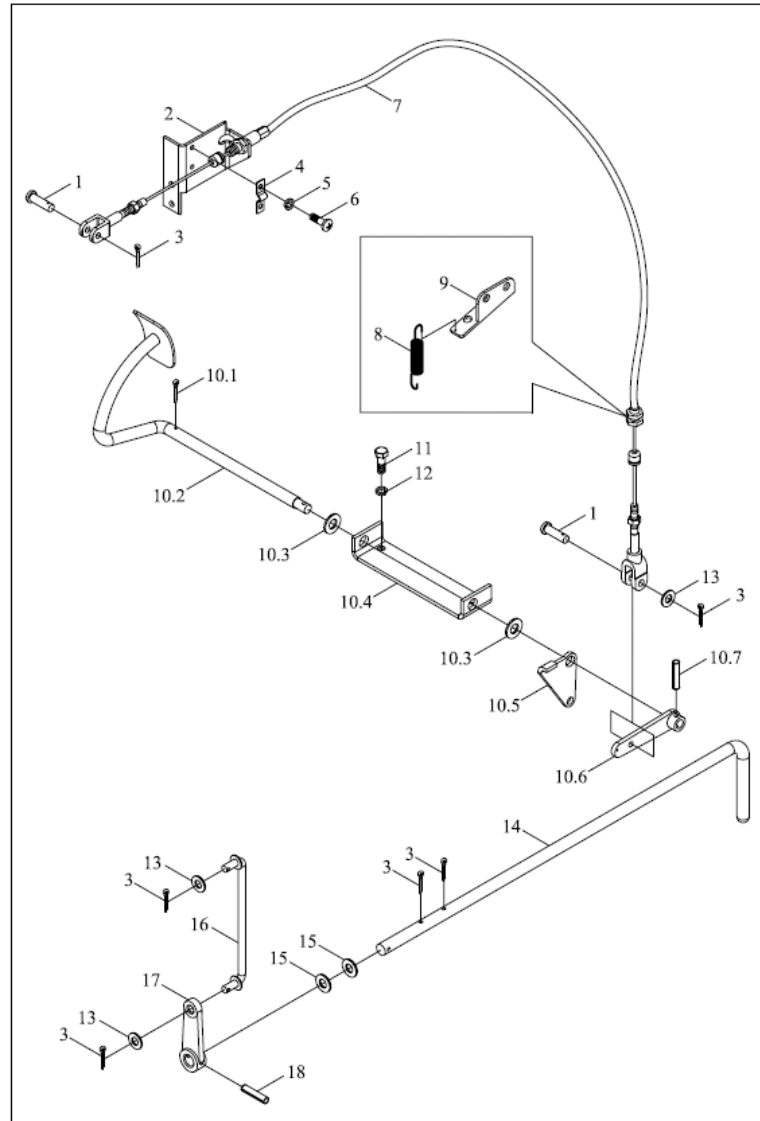

FT250.20B.001-2 20.2-发动机操纵机构总成-2 20.2ENGINE CONTROL MECHANISM ASSEMBLY-2

标号 No.	代号 Code	名称 Description		数量 Quantity	备注 Remark
1	GBT882-B5X20-A0P	销轴	PIN	1	2004-01_
10	TE250.20.3	脚油门组合件	FOOT THROTTLE UNIT	1	2011-11_
10.1	GBT91-2.5X25-A0P	开口销	PIN	1	2011-11_
10.2	FT250.20.021	脚油门传动轴焊合件	FOOT THROTTLE TRANSMISSION SHAFT	1	2011-11_
10.3	GBT97.1-12-A0P	平垫圈	WELDMENT WASHER	2	2011-11_
10.4	FT250.20.122	支撑板		1	2011-11_
10.5	FT250.20.106	手油门摇臂	SUPPORTING BOARD	1	2011-11_
10.6	TE250.20.3.1	脚油门摇臂焊合	HAND THROTTLE ROCKER	1	2011-11_
10.7	GBT879.1-4X16	弹性圆柱销	FOOT THROTTLE ROCKER ARM WELDMENT	1	2011-11_
11	GBT5781-M8X20-A2L	六角头螺栓	PIN BOLT	2	2011-11_
11	GBT5781-M8X20-A2L	六角头螺栓		2	2011-11_
12	GBT93-8-A0P	垫圈	BOLT	2	2011-11_
13	GBT97.1-6-A0P	平垫圈	WASHER	3	2011-11_
14	FT250.20B.117	减压手柄	WASHER	1	2011-11_
15	GBT97.1-10-A0P	平垫圈	DECOMPRESSION HANDLE WASHER	2	2011-11_
16	FT250.20.018	减压拉杆焊合		1	2011-11_
17	FT250.20.118	减压摇臂	DECOMPRESSION PULL ROD WELDMENT	1	2011-11_
18	GBT879.1-3X20	弹性圆柱销	DECOMPRESSION ROCKER	1	2011-11_
2	FT250.20.107	支架	PIN	1	2011-11_
3	GBT91-2X16-A0P	开口销	SUPPOT BRACKET PIN	6	2011-11_
4	FT250.20.127	固定夹		1	2011-11_
5	GBT93-5-A0P	标准型弹簧垫圈	LOCKING CLAMP	2	2011-11_
6	GBT818-M5X10-A2L	十字槽盘头螺钉	WASHER	2	2011-11_
7	FT250.20.015	脚油门拉线总成	SCREW	1	2011-11_
8	FT250.20.112	回位弹簧	FOOT THROTTLE WIRE ASSEMBLY	1	2011-11_

FT250.20B.001 发动机操纵机构总成-2

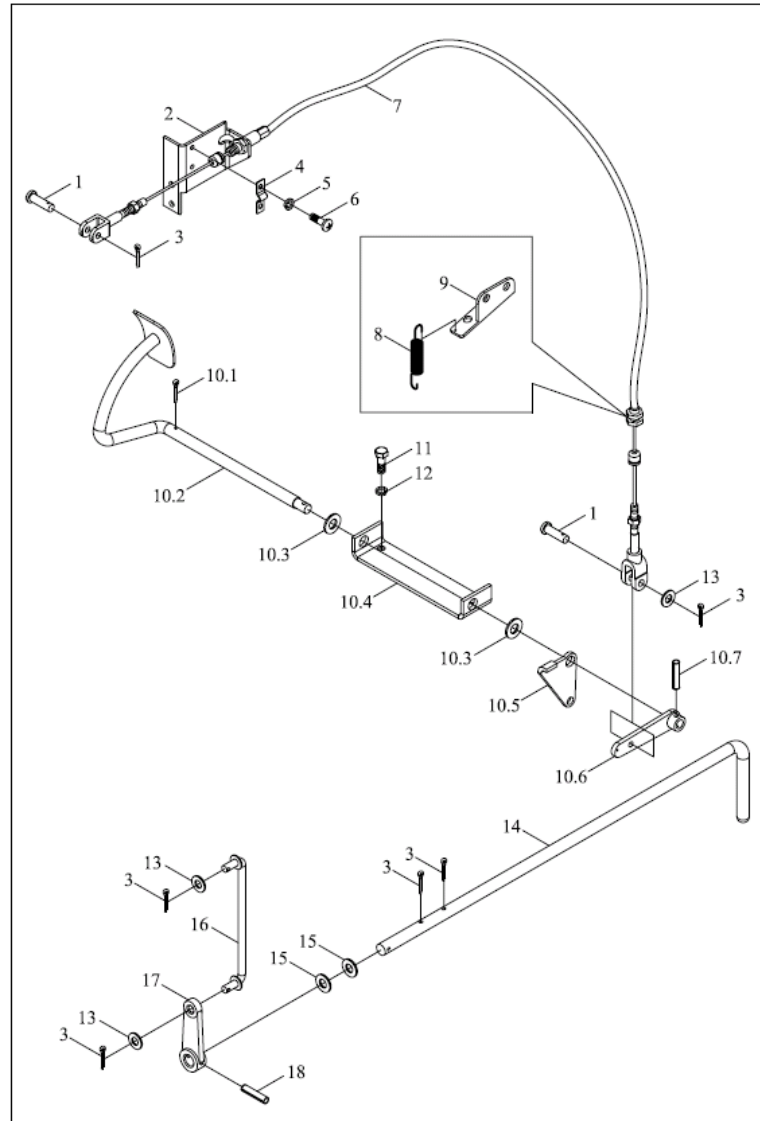

FT250.20B.001-2 20.2-发动机操纵机构总成-2(续)

标号 No.	代号 Code	名称 Description		数量 Quantity	备注 Remark
9	TE250.20-04	拉线支架	PULL WIRE BRACKET	1	2011-11_

FT250.21B.001 离合器总成-1

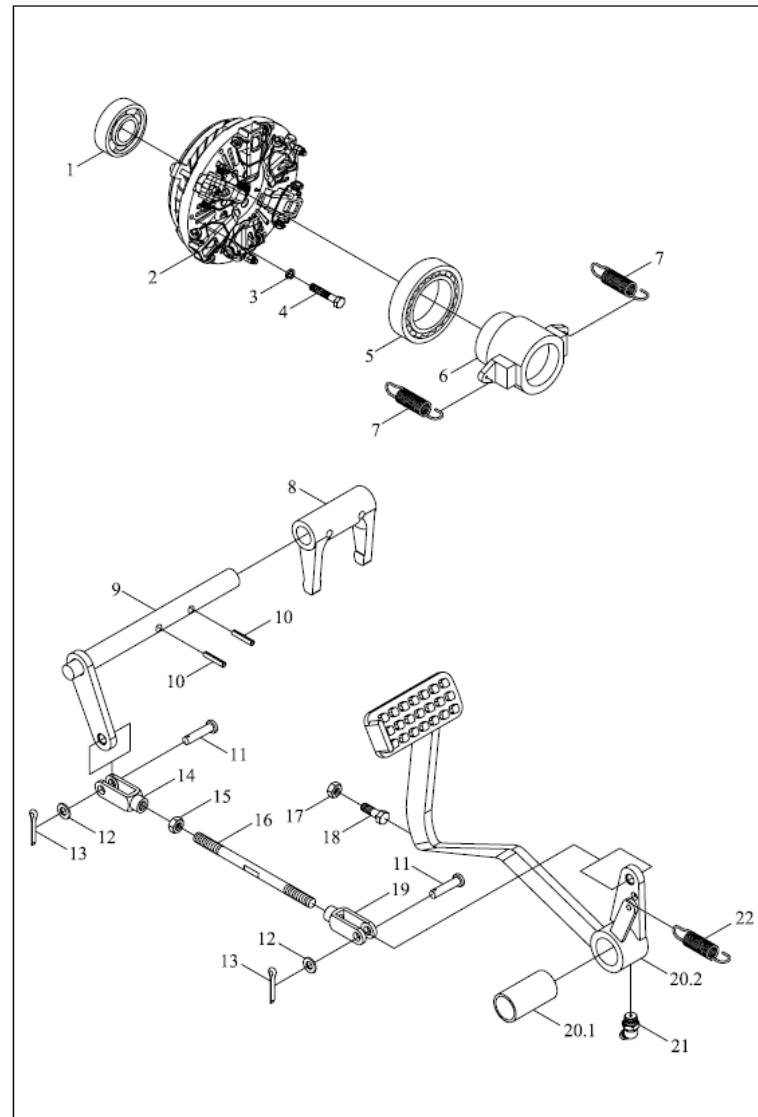

FT250.21B.001-1 21.1-离合器总成-1 CLUTCH ASSEMBLY-1

标号 No.	代号 Code	名称 Description		数量 Quantity	备注 Remark
1	GBT276-6203-2Z	深沟球轴承	BEARING	1	2011-11_
10	GBT879-8X32	销	PIN	2	2011-11_
11	GBT882-B10X28	销轴	PIN	2	2011-11_
12	GBT97.1-10-Zn.D	平垫圈	WASHER	2	2011-11_
13	GBT97.1-10-A0P	平垫圈	WASHER	2	2004-01_
14	FT300.43.108	拉杆前叉	PULL ROD FRONT FORK	1	2011-11_
15	GBT6172-M10-Zn.D	1型六角螺母	NUT	1	2011-11_
16	FT200.21.102	拉杆	PULL ROD	1	2011-11_
17	GBT6172-M12-Zn.D	1型六角螺母	NUT	1	2011-11_
18	GBT5783-M12X30-Zn.D	螺栓	BOLT	1	2011-11_
18	GBT5783-M12X30-Zn.D	螺栓	BOLT	1	2011-11_
19	FT300.43.110	拉杆后叉	PULL ROD REAR FORK	1	2011-11_
2	FT250.21B.011	离合器分总成	CLUTCH SUBASSEMBLY	1	2011-11_
20	FT200.21.014	离合器踏板总成	CLUTCH PEDAL ASSEMBLY	1	2011-11_
20.1	FT200.21.129	离合器踏板轴衬套	CLUTCH PEDAL SHAFT BUSH	1	2011-11_
20.2	FT200.21.020	离合器踏板焊合件	CLUTCH PEDAL WELDMENT	1	2011-11_
21	GBT1153-45° M10X1	油杯	OIL CUP	1	2011-11_
21	GBT1153-45° M10X1	油杯	OIL CUP	1	2011-11_
22	FT200.21.101	离合器踏板弹簧	CLUTCH PEDAL SPRING	1	2011-11_
3	GBT93-8-A0P	垫圈	WASHER	6	2004-01_
4	GBT5783-M8X65-8.8-A2L	六角头螺栓	BOLT	6	2004-01_
5	TE250.212B-01	分离轴承	BEARING	1	2004-01_
6	FT200.21B.103	分离轴承座	RELEASE BEARING SEAT	1	2011-11_
7	FT200.21.106	分离轴承座回位弹簧	RETURN SPRING OF RELEASE BEARING SEAT	2	2011-11_
8	FT200.21.105	离合器拨叉	CLUTCH FORK	1	2004-01_

FT250.21B.001 离合器总成-1

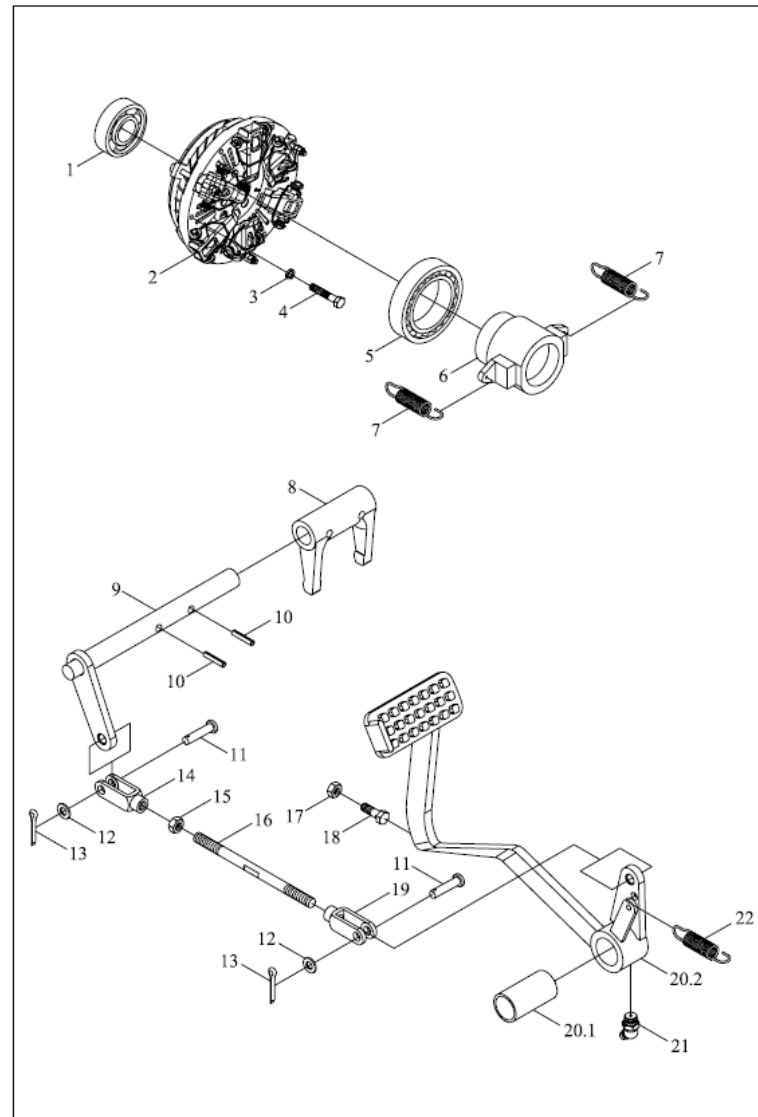

FT250.21B.001-1 21.1-离合器总成-1(续)

标号 No.	代号 Code	名称 Description		数量 Quantity	备注 Remark
8	FT200.21.105a	离合器拨叉	CLUTCH FORK	1	2009-04_
9	FT200.21.013	离合器分离摇臂合件	CLUTCH RELEASE ROCKER UNIT	1	2004-01_
9	FT200.21.013a	离合器分离摇臂合件	CLUTCH RELEASE ROCKER UNIT	1	2009-04_

FT250.21B.001 离合器总成-2

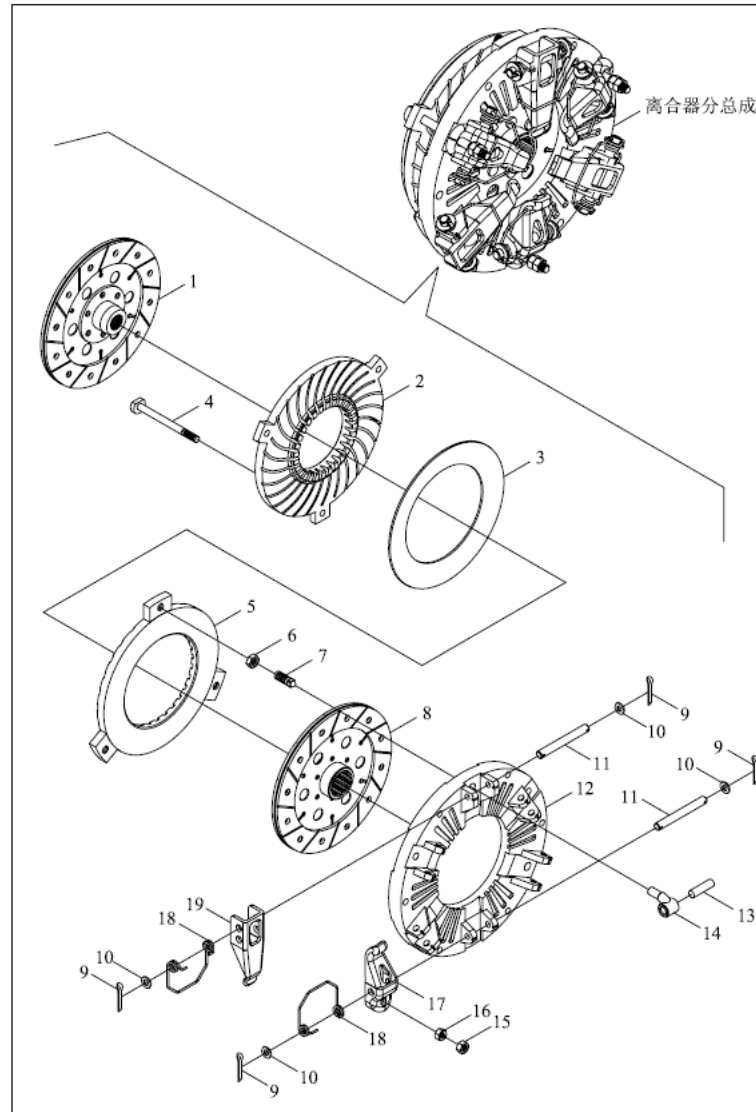

FT250.21B.001-2 21.2-离合器总成-2 CLUTCH ASSEMBLY-2

标号 No.	代号 Code	名称 Description		数量 Quantity	备注 Remark
0	FT250.21B.011	离合器分总成	CLUTCH SUBASSEMBLY	1	2011-11_
1	FT250.21B.014	副摩擦片总成	AUXILIARY FRICTION PIECE ASSEMBLY	1	2013-02_
1	FT200.21B.014	副离合器从动盘总成	AUXILIARY CLUTCH DRIVEN PLATE ASSEMBLY	1	2011-11_
10	GBT848-10-Zn.D	平垫	WASHER	12	2011-11_
11	FT300.21B.111	长销	LONG PIN	6	2011-11_
12	FT200.21B.115	离合器盖	CLUTCH COVER	1	2011-11_
13	FT300.21B.109	销轴	PIN	3	2011-11_
14	FT200.21B.114	主离合器分离推杆	MAIN CLUTCH RELEASE PULL ROD	1	2011-11_
15	GBT6171-M8X1-Zn.D	1型六角螺母	NUT	3	2011-11_
16	FT300.21B.105	球头螺母	BALL NUT	3	2011-11_
16	FT300.21B.105	球头螺母	BALL NUT	3	2011-11_
17	FT200.21B.118	副离合器分离杠杆	AUXILIARY CLUTCH RELEASE LEVER	3	2011-11_
17	FT250.21B.118	副离合器分离杠杆	AUXILIARY CLUTCH RELEASE LEVER	3	2013-02_
18	FT250.21B.121	分离杆弹簧	RELEASE ROD SPRING	6	2013-02_
18	FT200.21B.116	离合器分离杠杆弹簧	CLUTCH RELEASE LEVER SPRING	6	2011-11_
19	FT250.21B.117	主离合器分离杠杆	MAIN CLUTCH RELEASE LEVER	3	2013-02_
19	FT200.21B.117	主离合器分离杠杆	MAIN CLUTCH RELEASE LEVER	3	2011-11_
19	FT200.21B.117	主离合器分离杠杆	MAIN CLUTCH RELEASE LEVER	3	2011-11_
2	FT250.21B.112	副离合器压盘	AUXILIARY CLUTCH PRESSURE PLATE	1	2011-11_
3	FT250.21B.105	碟形弹簧	DISC SPRING	1	2011-11_
3	FT250.21B.105	碟形弹簧	DISC SPRING	1	2011-11_
4	FT400.21B.104	副离合器拉杆	AUXILIARY CLUTCH PULL ROD	3	2011-11_
5	FT250.21B.113	主离合器压盘	MAIN CLUTCH PRESSURE PLATE	1	2011-11_
5	FT250.21B.126	主压板	PRESSURE PLATE	1	2011-11_
6	GBT6173-M10X1-Zn.D	六角薄螺母	NUT	3	2011-11_

FT250.21B.001 离合器总成-2

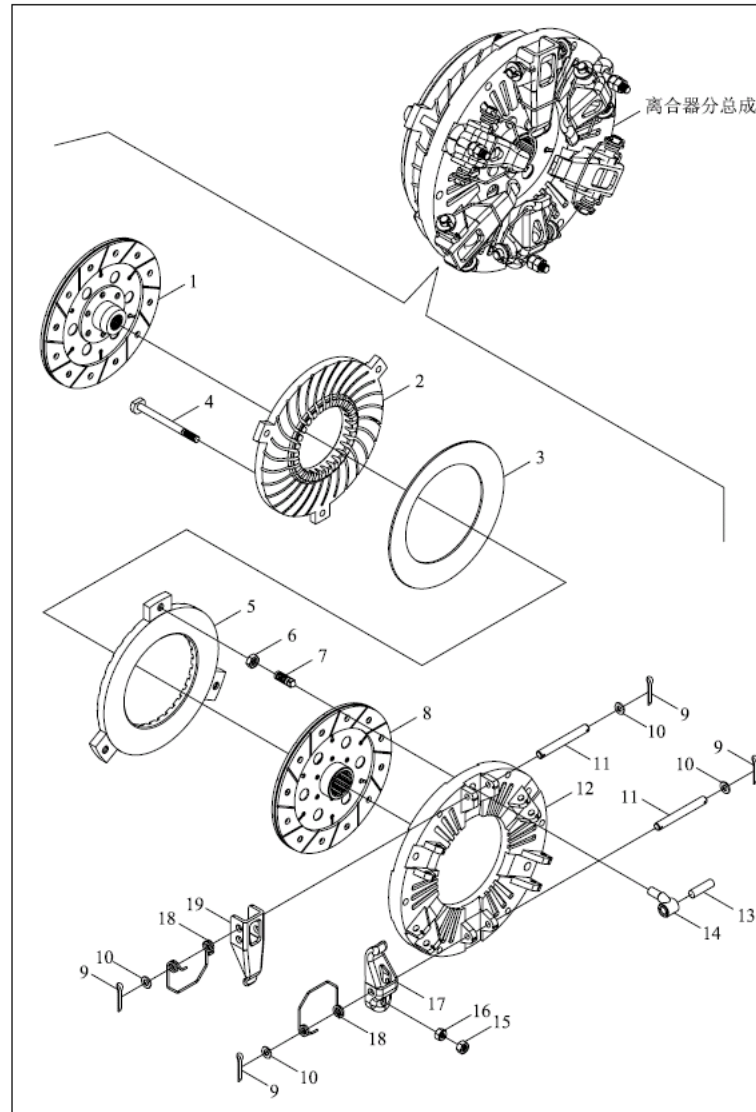

FT250.21B.001-2 21.2-离合器总成-2(续)

标号 No.	代号 Code	名称 Description		数量 Quantity	备注 Remark
6	GBT6173-M10X1-Zn.D	六角薄螺母	NUT	3	2011-11_
7	FT200.21B.110	主离合器调整螺钉	MAIN CLUTCH ADJUSTING SCREW	3	2011-11_
8	FT250.21B.017	主离合器从动盘总成	MAIN CLUTCH DRIVEN PLATE ASSEMBLY	1	2011-11_
9	GBT91-3.2X20	销	PIN	12	2004-01_

FT250.22B.001 排气系总成

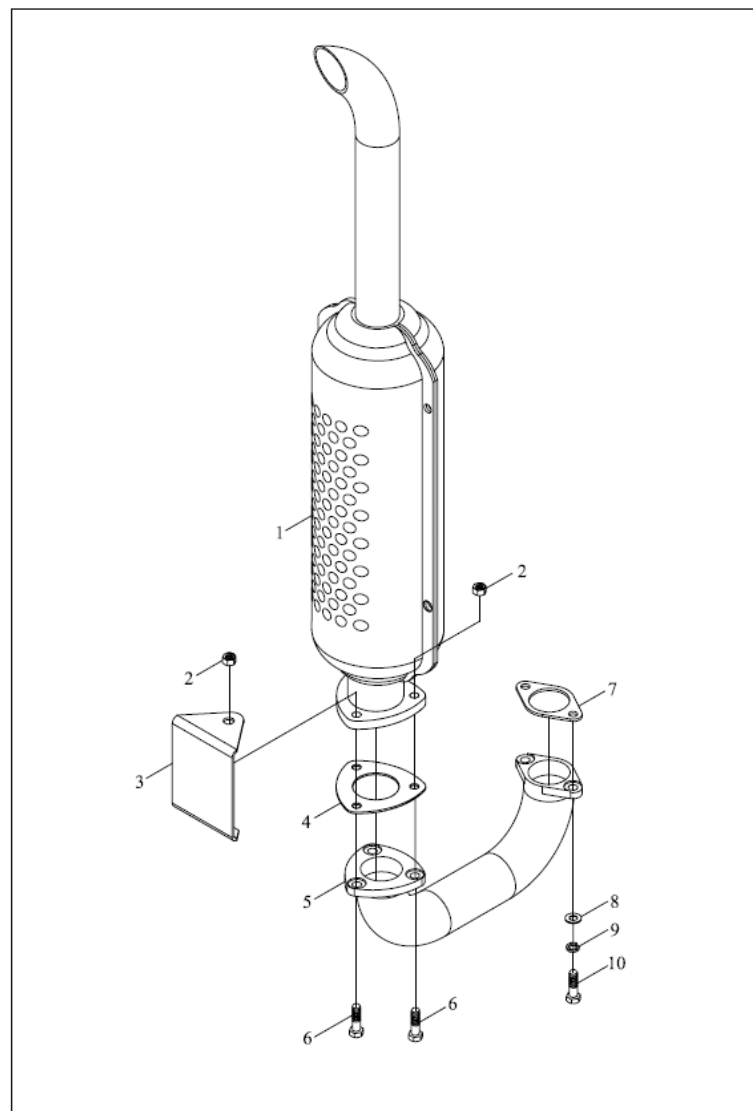

FT250.22B.001 22-排气系总成 22-EXHAUST SYSTEM ASSEMBLY

标号 No.	代号 Code	名称 Description		数量 Quantity	备注 Remark
1	FT250.22.010	消音器总成	MUFFLE ASSEMBLY	1	2011-11_
10	GBT5783-M10X30-A3L	螺栓	BOLT	2	2011-11_
3	FT250.22B.125	排气系标识架	EXHAUST SYSTEM SIGN BRACKET	1	2011-11_
4	FT250.22.030	密封垫合件	SEAL GASKET UNIT	1	2011-11_
5	TE250.22-01	排气弯管	EXHAUST BENDING PIPE	1	2007-12_
5	FT250.22B.111	排气弯管	EXHAUST BENDING PIPE	1	2011-11_
6	GBT5783-M8X16-A2L	螺栓	BOLT	4	2004-01_
7	FT250.22C.030	密封垫合件	SEAL GASKET UNIT	1	2011-11_
8	GBT97.1-10-A0P	平垫圈	WASHER	2	2011-11_
9	GBT93-10-A0P	标准型弹簧垫圈	WASHER	2	2011-11_

FT250.24.001 蓄电池安装总成

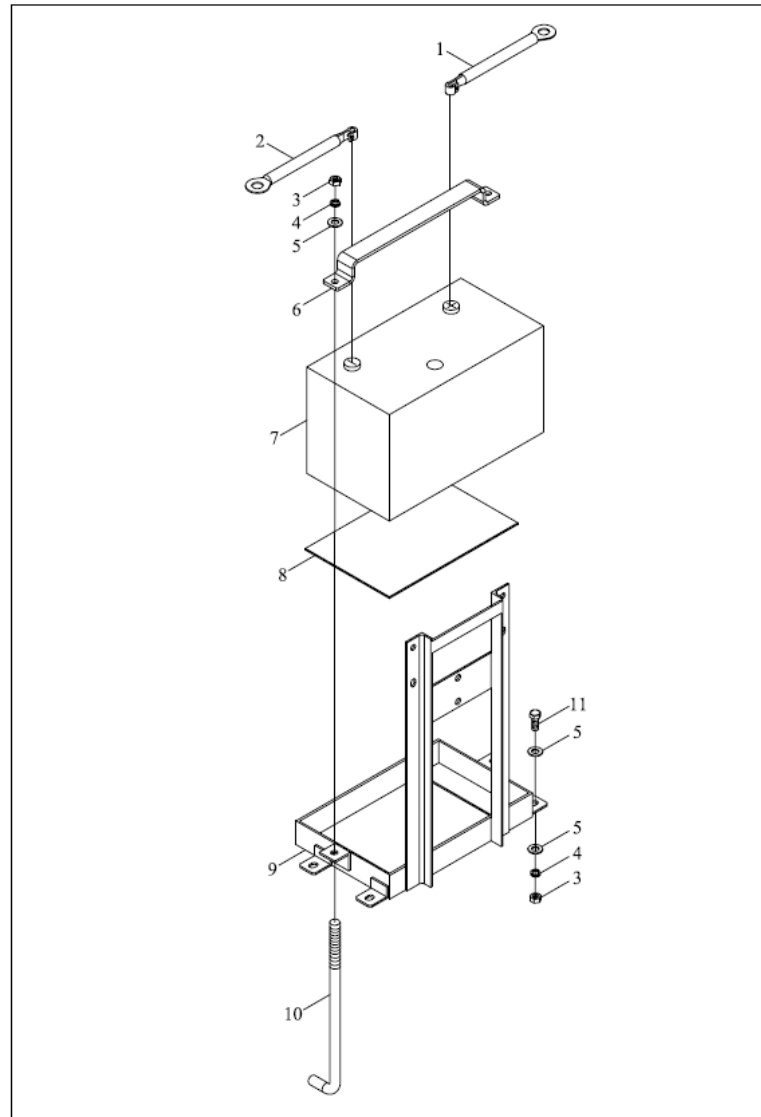

FT250.24.001 24-蓄电池安装总成 24-BATTERY INSTALLATION ASSEMBLY

标号 No.	代号 Code	名称 Description		数量 Quantity	备注 Remark
1	FT250.48.027	蓄电池正极电缆总成	BATTERY POSITIVE CABLE ASSEMBLY	1	2011-11_
10	FT250.24.102	电瓶拉杆	BATTERY PULL ROD	2	2011-11_
11	GBT5783-M8X20-A2L	螺栓	BOLT	4	2011-11_
2	FT250.48.028	蓄电池负极电缆总成	BATTERY CATHODE CABLE ASSEMBLY	1	2011-11_
3	GBT6170-M8-A2L	螺母	NUT	6	2011-11_
4	GBT93-8-A0P	垫圈	WASHER	6	2011-11_
5	GBT97.1-8-A0P	平垫圈	WASHER	10	2011-11_
6	FT250.24.101	电瓶压板	BATTERY PRESS PLATE	1	2011-11_
7	FT250.48.029	蓄电池总成	BATTERY ASSEMBLY	1	2011-11_
8	FT250.24.103	橡胶皮	RUBBER SKIN	1	2011-11_
9	FT250.24.011a	电瓶固定架	BATTERY FIXING BRACKET	1	2011-11_

FT254.32.001 前驱动轮总成

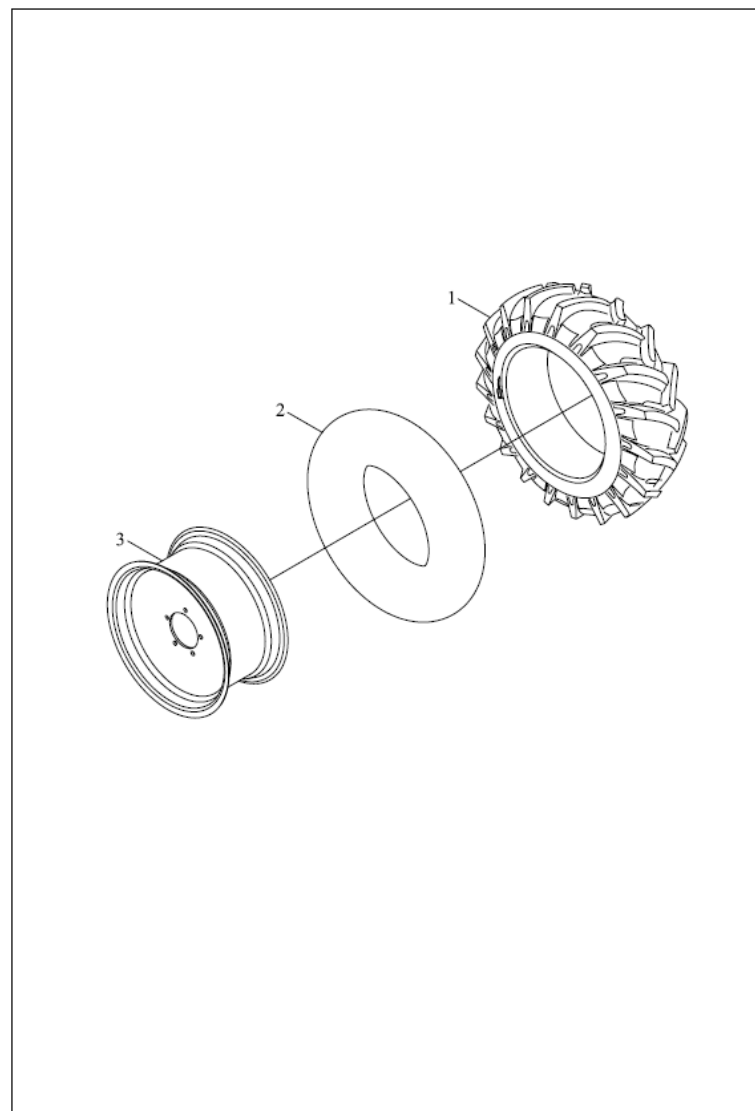

FT254.32.001 32-前驱动轮总成 32-FRONT DRIVING WHEEL ASSEMBLY

标号 No.	代号 Code	名称 Description		数量 Quantity	备注 Remark
1	GBT2979-6.00-14-6PR	拖拉机驱动轮普通断面斜交结构外胎	DRIVING WHEEL OUTER TUBE	1	2011-11_
2	GBT2979-6.00-14	拖拉机驱动轮内胎	DRIVING WHEEL INNER TUBE	1	2011-11_
3	FT254.32.011	前轮辋总成	FRONT WHEEL RIM ASSEMBLY	1	2011-11_

FT250.34.001 驱动轮总成

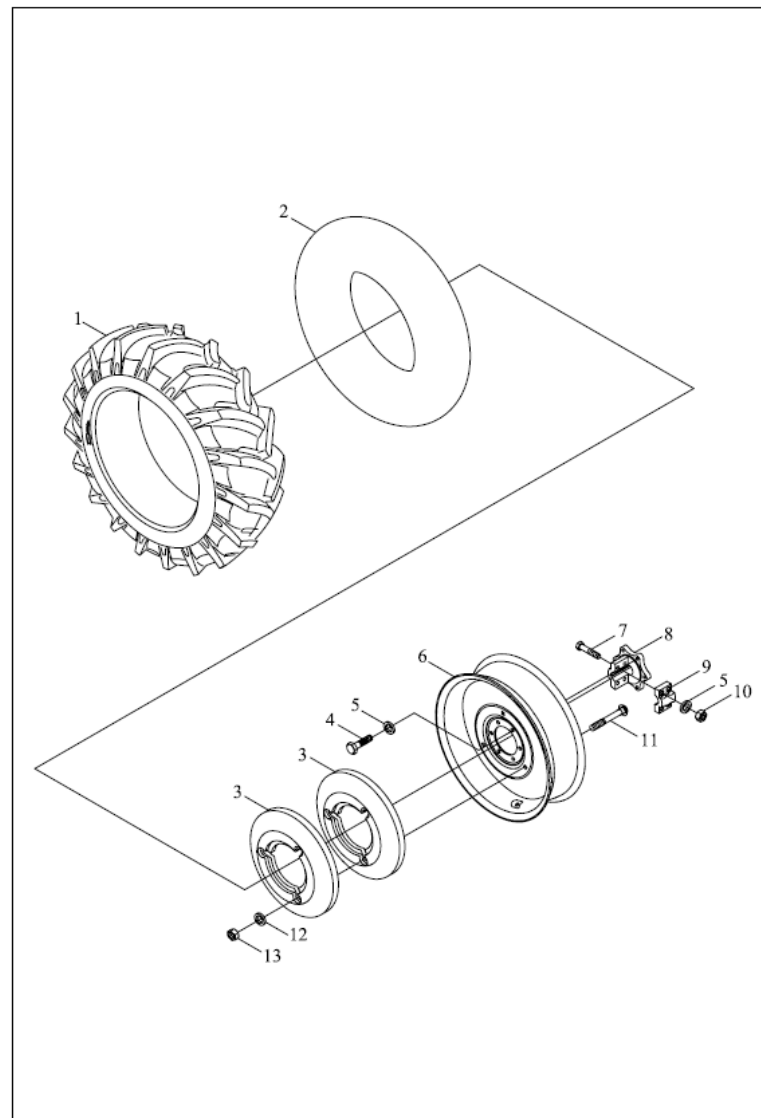

FT250.34.001 34-驱动轮总成 34-DRIVING WHEEL ASSEMBLY

标号 No.	代号 Code	名称 Description	数量 Quantity	备注 Remark
1	GBT2979-9.5-24-6PR	拖拉机驱动轮普通断面斜交结构外胎	1	2011-11_
10	GBT6171-M14X1.5-10-A3L	1型六角螺母	4	2011-11_
11	GBT12-M14X85-10.9-A3L	半圆头方颈螺栓	3	2011-11_
12	FT250.34.107	垫圈	3	2011-11_
13	GBT6170-M14-10-A3L	1型六角螺母	3	2011-11_
13	GBT6170-M14-10-A3L	1型六角螺母	3	2011-11_
2	GBT2979-9.5-24	拖拉机驱动轮内胎	1	2011-11_
3	FT250.34.101	驱动轮配重	2	2011-11_
3	FT250.34.101	驱动轮配重	2	2011-11_
4	GBT5786-M14X1.5X35-10.9-A3L	六角头螺栓	6	2011-11_
5	FT250.34.108	轮毂垫圈	10	2011-11_
6	FT250.34.011	轮辋合件	1	2011-11_
7	GBT5785-M14X1.5X80-10.9-A3L	六角头螺栓	4	2011-11_
8	FT250.34.102	驱动轮轮毂	1	2011-11_
8	FT250.34.102a	驱动轮轮毂	1	2013-04_
9	FT250.34.103	驱动轮轮毂盖	1	2011-11_
9	FT250.34.103a	驱动轮轮毂盖	1	2013-04_

FT250.35.001 牵引装置装配总成

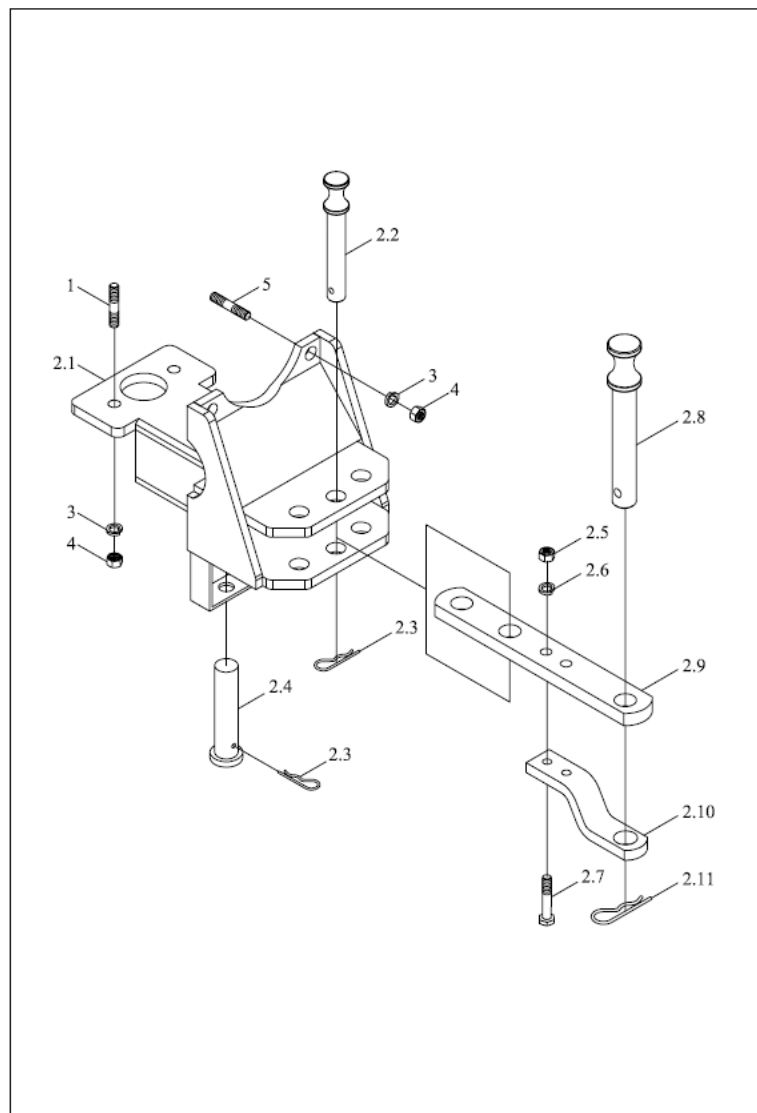

FT250.35.001 35-牵引装置装配总成 35-TRACTION EQUIPMENT MOUNTING ASSEMBLY

标号 No.	代号 Code	名称 Description		数量 Quantity	备注 Remark
1	GBT5783-M12X35-8.8-A3L	六角头螺栓	BOLT	2	2011-07_
1	GBT899-GM12-M12X35-A3L	双头螺柱	8.8-A3L STUD	2	2011-11_
2	FT250.35.011	牵引装置总成	TRACTION DEVICE ASSEMBLY	1	2011-11_
2.1	FT250.35.010	牵引架焊合	TRACTION FRAME	1	2011-11_
2.1	FT300.35A.101	连接摆杆	CONNECTING SWING ROD	1	2011-11_
2.11	FT800.35.112	弹性锁销	SPRING LOCK PIN	1	2011-11_
2.2	FT250.35.103	限位销	LIMITING PIN	1	2011-11_
2.3	FT65.35.103	弹性锁销	SPRING LOCK PIN	2	2011-11_
2.3	FT65.35.103	弹性锁销	SPRING LOCK PIN	2	2011-11_
2.4	FT250.35.101	连接销	CONNECTING PIN	1	2011-11_
2.5	GBT6170-M16-A3L	螺母M16-A3L	NUT M16-A3L	2	2011-11_
2.6	GBT93-16-AOP	垫圈	WASHER	2	2008-05_
2.7	GBT5782-M16X80-A3L	六角头螺栓	BOLT	2	2011-11_
2.8	FT300.35A.105	摆销	SWING PIN	1	2011-11_
2.9	FT250.35.102	摆杆	UPPER PART U-HOOK	1	2011-11_
3	GBT93-12-AOP	垫圈	WASHER	4	2011-11_
4	GBT6170-M12-A3L	螺母	NUT	4	2011-11_
5	GBT899-GM12-M12X35-A3L	双头螺柱	8.8-A3L STUD	2	2011-07_
5	GBT16674.1-M12X30-8.8-A3L	六角法兰面螺栓	BOLT	2	2012-02_

FT250.36B.001 离合器壳总成-1

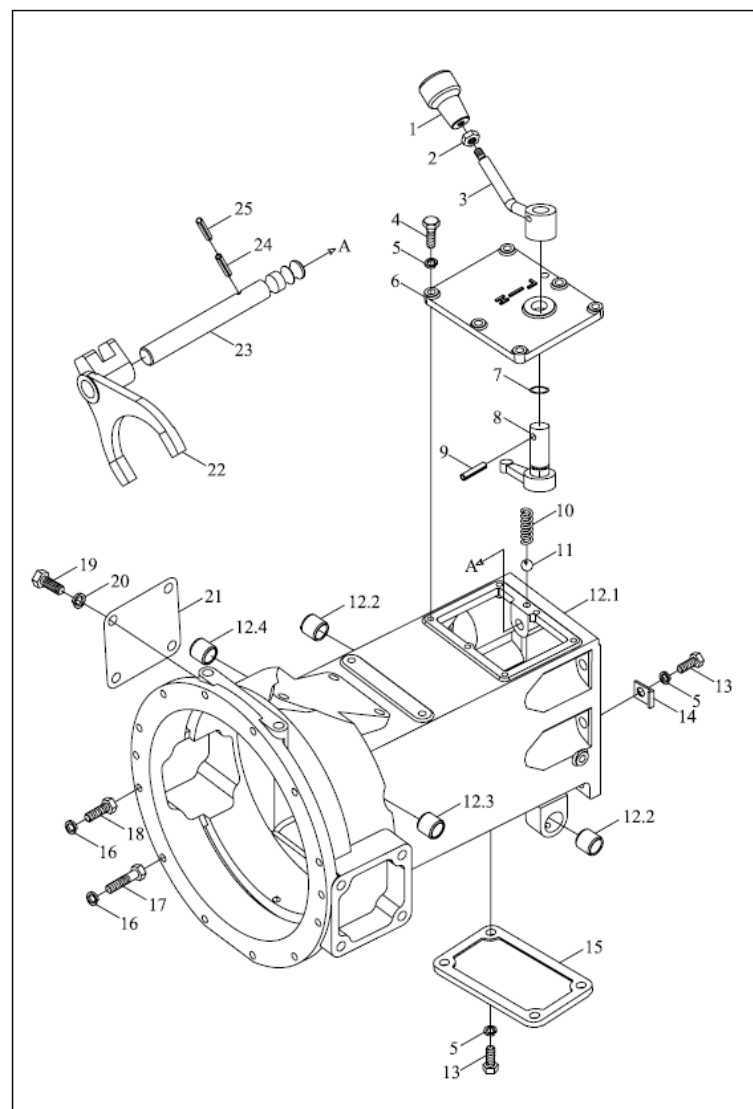

FT250.36B.001-1 36.1-离合器壳总成-1 CLUTCH HOUSING ASSEMBLY -1

标号 No.	代号 Code	名称 Description		数量 Quantity	备注 Remark
1	FT250.36B.020	爬行档操纵手柄	CREEPER GEAR CONTROL HANDLE	1	2011-11_
10	FT250.37.148	拨叉轴锁定弹簧	FORK SHAFT LOCKING SPRING	1	2011-11_
10	FT250.37.148	拨叉轴锁定弹簧	FORK SHAFT LOCKING SPRING	1	2011-11_
12	FT250.36.011	离合器壳分总成	CLUTCH HOUSING SUBASSEMBLY	1	2011-11_
12.1	FT250.36.101	离合器壳	CLUTCH HOUSING	1	2011-11_
12.2	FT250.36.104	踏板轴衬套	PEDAL SHAFT BUSH	2	2011-11_
12.3	FT250.36.103	摇臂轴长衬套	ROCKER SHAFT LONG BUSH	1	2011-11_
12.4	FT250.36.102	摇臂轴短衬套	ROCKER SHAFT SHORT BUSH	1	2011-11_
13	GBT5783-M8X20-A2L	螺栓	BOLT	6	2011-11_
14	FT250.36B.115	挡片	RETAINER PIECE	2	2011-11_
15	FT250.36.108	盖板	COVER PLATE	1	2011-11_
16	GBT93-10-A0P	标准型弹簧垫圈	WASHER	11	2011-11_
17	GBT5782-M10X85-A2L	六角头螺栓	BOLT	10	2011-11_
18	GBT5783-M10X35-A3L	螺栓	BOLT	1	2011-11_
19	GBT5781-M14X20-A2L	六角头螺栓	BOLT	4	2011-11_
2	GBT6172.1-M10-A3L	螺母	NUT	1	2011-11_
20	GBT93-14-A0P	弹簧垫圈	SPRING WASHER	4	2011-11_
20	GBT93-14-A0P	弹簧垫圈	SPRING WASHER	4	2011-11_
21	FT250.36.110	检查孔侧盖	INSPECTION HOLE SIDE COVER	1	2011-11_
22	FT250.36B.123	爬行档拨叉	CREEPER GEAR FORK	1	2011-11_
22	FT250.36B.123	爬行档拨叉	CREEPER GEAR FORK	1	2011-11_
23	FT250.36B.119	爬行档拨叉轴	CREEPER GEAR FORK SHAFT	1	2011-11_
24	GBT879.1-3X24	弹性圆柱销	PIN	1	2011-11_
25	GBT879.1-5X24	弹性圆柱销	PIN	1	2011-11_
3	FT250.36B.018	爬行档变速杆焊合	CREEPER GEARSHIFT LEVER WELDMENT	1	2011-11_

FT250.36B.001 离合器壳总成-1

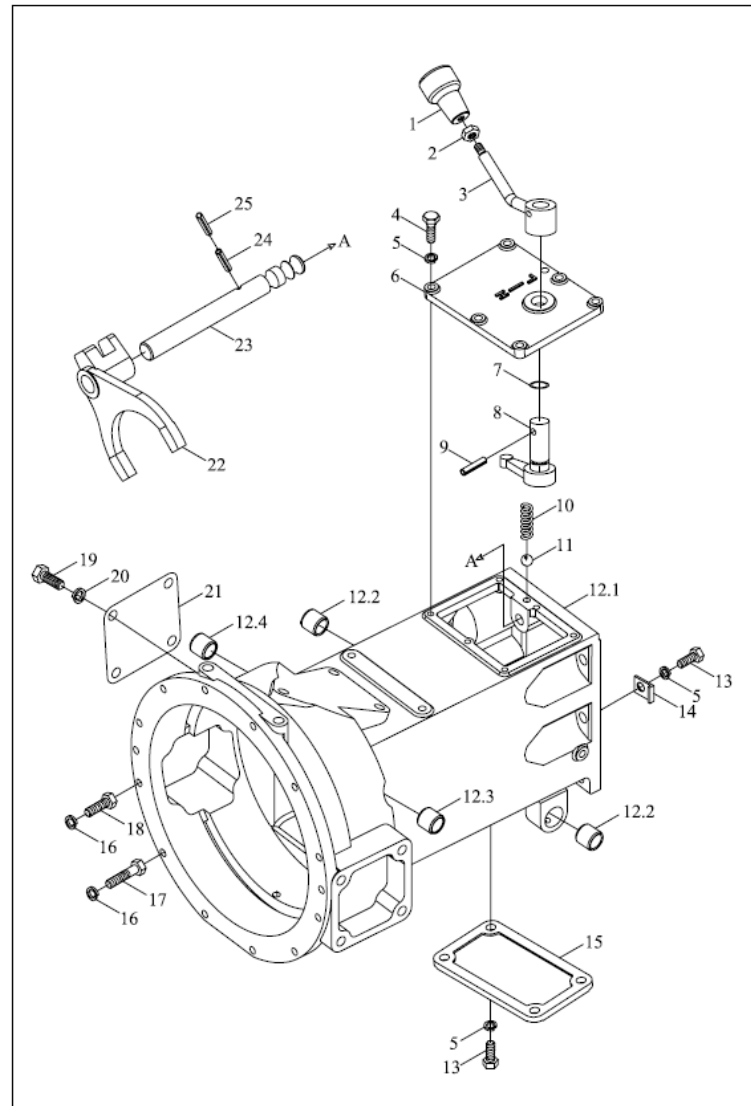

FT250.36B.001-1 36.1-离合器壳总成-1(续)

标号 No.	代号 Code	名称 Description		数量 Quantity	备注 Remark
4	GBT5783-M8X25-A2L	螺栓	BOLT	6	2011-11_
5	GBT93-8-A0P	垫圈	WASHER	12	2011-11_
6	FT250.36B.121	爬行档变速盖	CREEPER GEARSHIFT COVER	1	2011-11_
7	GBT3452.1-13.2X2.65G	液压气动用O形橡胶密封圈	O-SEAL RING	1	2011-11_
8	FT250.36B.124	副变速摇臂	AUXILIARY GEARSHIFT ROCKER	1	2011-11_
9	GBT879.1-6X35	弹性圆柱销	PIN	1	2011-11_

FT250.36B.001 离合器壳总成-2

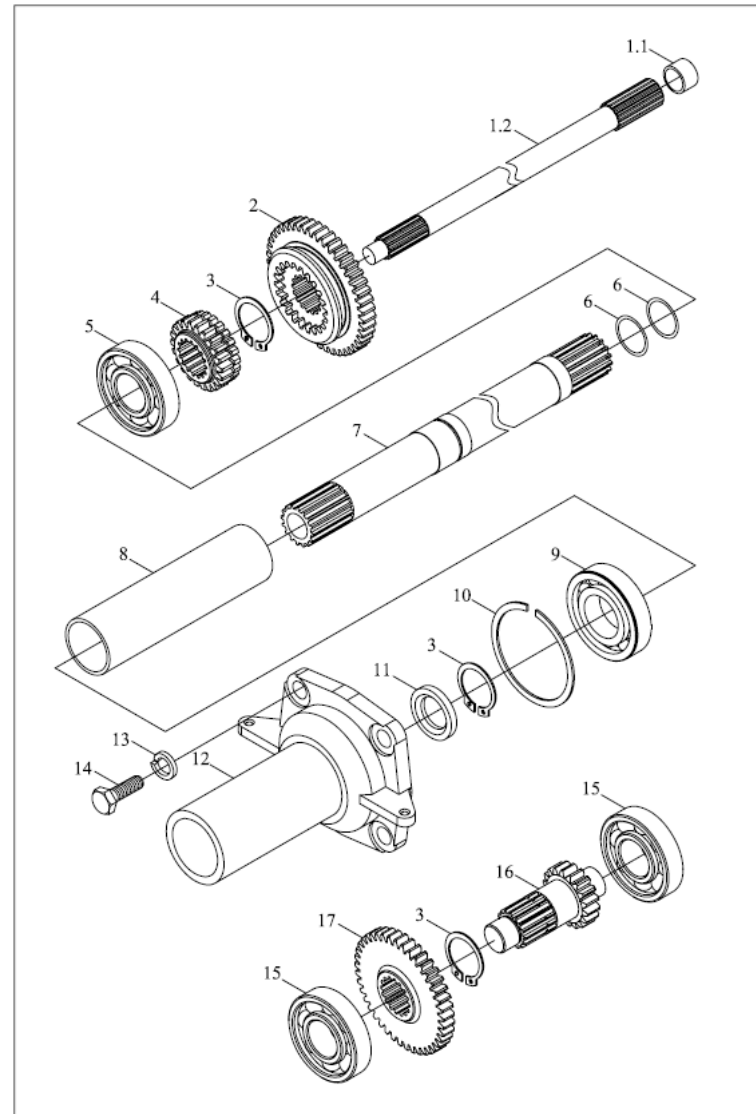

FT250.36B.001-2 36.2-离合器壳总成-2 CLUTCH HOUSING ASSEMBLY -2

标号 No.	代号 Code	名称 Description		数量 Quantity	备注 Remark
1	FT250.36B.016	功率输出离合器轴总成	PTO CLUTCH SHAFT ASSEMBLY	1	2011-11_
1.1	FT250.36B.128	轴套	SHAFT SLEEVE	1	2011-11_
1.2	FT250.36B.125	功率输出离合器轴	PTO CLUTCH SHAFT	1	2011-11_
10	GBT305-72/78.6	止推环	PLATE;THRUST	1	2011-11_
11	GBT9877.1-G35X55X8	内包骨架旋转轴唇形密封	O RING	1	2011-11_
12	FT250.36B.109	分离轴承座支座	RELEASE BEARING SEAT SUPPORT	1	2011-11_
13	GBT93-10-A0P	标准型弹簧垫圈	WASHER	4	2011-11_
14	GBT5783-M10X25-A3L	螺栓	BOLT	4	2011-11_
15	GBT276-6305	轴承	BEARING	2	2011-11_
16	FT250.36B.114	爬行档固定齿轮	CREEPER FIXING GEAR	1	2011-11_
17	FT250.36B.113	爬行档从动齿轮	CREEPER DRIVEN GEAR	1	2011-11_
2	FT250.36B.116	爬行档滑动齿轮	CREEPER SLIDE GEAR	1	2011-11_
3	GBT894.1-34	轴用弹性挡圈	SNAP RING	3	2011-11_
4	FT250.36B.117	爬行档主动齿轮	CREEPER GEAR DRIVING GEAR	1	2011-11_
5	GBT276-6207	轴承	BEARING	1	2011-11_
6	GBT3452.1-20X2.65G	液压气动用O形橡胶密封圈	O-SEAL RING	2	2011-11_
7	FT250.36B.111	爬行档主动轴	CREEPER DRIVING SHAFT	1	2011-11_
8	FT250.36B.112	定位套	LOCATING SLEEVE	1	2011-11_
9	GBT276-6207N	轴承	BEARING	1	2011-11_

FT250.37C.001 传动箱总成-1

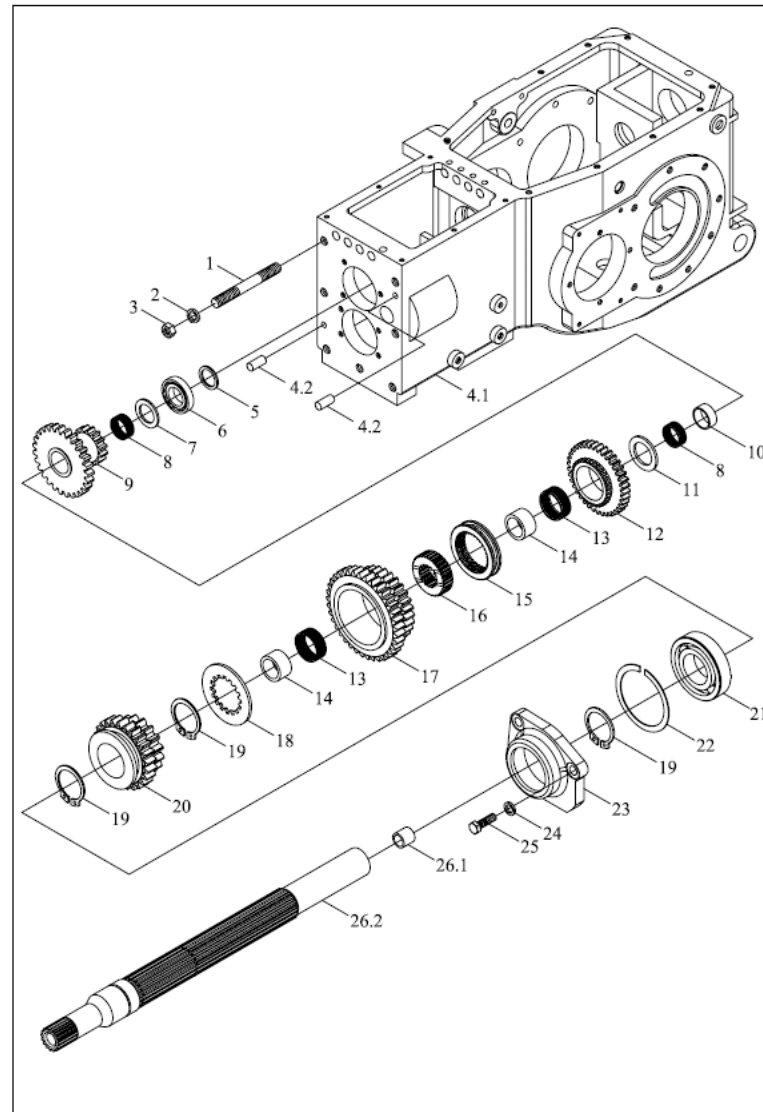

FT250.37C.001-1 37.1-传动箱总成-1 TRANSMISSION CASE ASSEMBLY-1

标号 No.	代号 Code	名称 Description		数量 Quantity	备注 Remark
1	GBT898-AM14-M14X1.5X35-A3L	双头螺柱	8.8-A3L STUD	7	2011-11_
10	FT250.37.139	短隔套	SHORT SPACER	1	2011-11_
11	FT250.37.138	IV档主动齿轮挡圈	IV DRIVING GEAR RETAINING RING	1	2011-11_
12	FT250.37.140	IV档主动齿轮	IV DRIVING GEAR	1	2011-11_
14	FT250.37.134	齿轮滑套	GEAR SLIDING SLEEVE	2	2011-11_
15	FT250.37.136	啮合套	SHIFT COLLAR	1	2011-11_
16	FT250.37.135	啮合齿座	MESH GEAR SEAT	1	2011-11_
17	FT250.37.144	III档主动齿轮	III DRIVING GEAR	1	2011-11_
18	FT250.37.133	III档主动齿轮挡圈	III DRIVING GEAR RETAINER RING	1	2011-11_
19	GBT894.1-34	轴用弹性挡圈	SNAP RING	3	2011-11_
2	GBT93-14-A0P	弹簧垫圈	SPRING WASHER	7	2011-11_
2	GBT93-14-A0P	弹簧垫圈	SPRING WASHER	7	2011-11_
20	FT250.37.130	I-II档滑动齿轮	I-II SLIDING GEAR	1	2011-11_
21	GBT276-6207N	轴承	BEARING	1	2011-11_
22	GBT305-72-78.6	止动环	THRUST RING	1	2004-01_
23	FT250.37.128	一轴前轴承盖	1ST SHAFT FRONT BEARING COVER	1	2011-11_
24	GBT93-10-A0P	标准型弹簧垫圈	WASHER	3	2011-11_
25	GBT5783-M10X25-A2L	六角头螺栓	BOLT	3	2011-11_
26	FT250.37A.014	第一轴总成	FIRST SHAFT ASSEMBLY	1	2011-11_
26.1	FT250.37A.137	轴套	SHAFT SLEEVE	1	2011-11_
26.2	FT250.37A.132	第一轴	FIRST SHAFT	1	2011-11_
3	GBT6171-M14X1.5-A3L	1型六角螺母	NUT	7	2011-11_
4	FT250.37B.011a	传动箱壳总成	TRANSMISSION CASE SHELL ASSEMBLY	1	2011-08_
4	FT250.37B.011	传动箱壳总成	TRANSMISSION CASE SHELL ASSEMBLY	1	2004-01_
4	FT250.37.011	传动箱壳总成	TRANSMISSION CASE SHELL ASSEMBLY	1	2004-01_

FT250.37C.001 传动箱总成-1

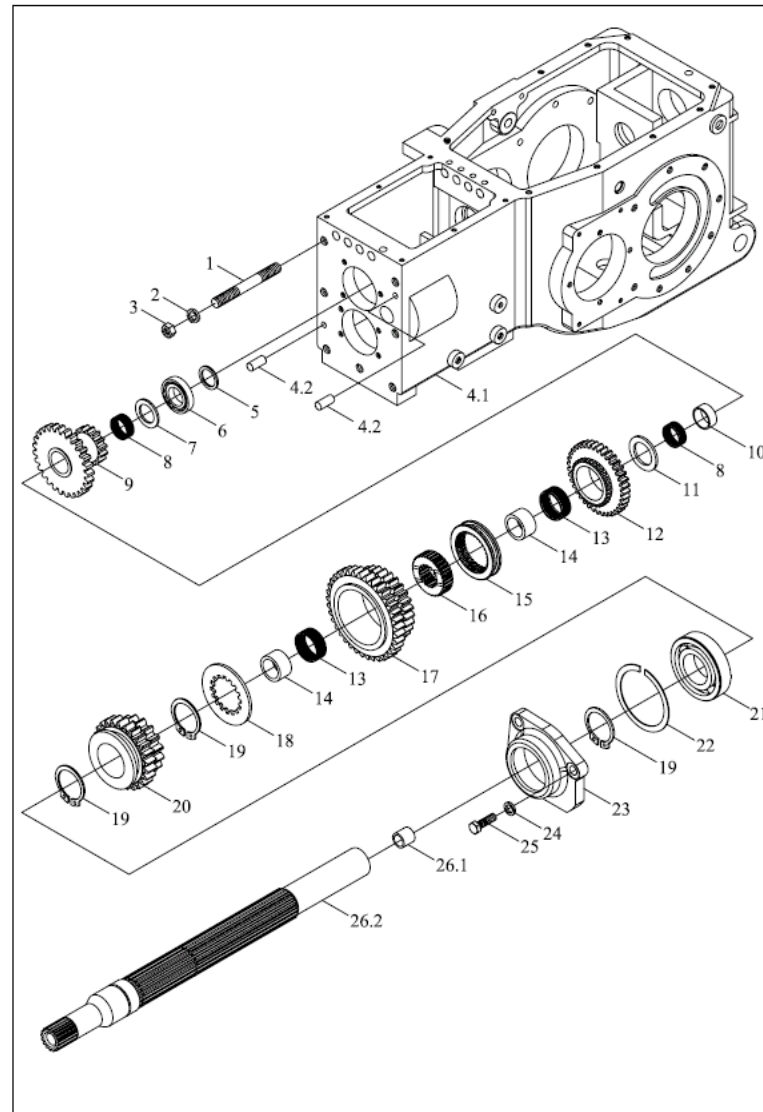

FT250.37C.001-1 37.1-传动箱总成-1(续)

标号 No.	代号 Code	名称 Description	数量 Quantity	备注 Remark
4	FT250.37.011	传动箱壳总成	1	2004-01_
4	FT250.37.011a	传动箱壳总成	1	2011-08_
4.1	FT250.37.101	传动箱壳	1	2011-11_
4.2	GBT119.1-10m6X26-A0P	圆柱销	2	2011-11_
5	FT250.37A.272	止推环	1	2011-11_
6	GBT283-NJ206E	轴承	1	2011-11_
7	FT250.37A.147	一轴副变速隔套	1	2011-11_
8	JBT7918-K30X35X27	向心滚针和保持架组件	2	2004-01_
9	FT250.37.146	高低档固定齿轮	1	2011-11_

FT250.37C.001 传动箱总成-2

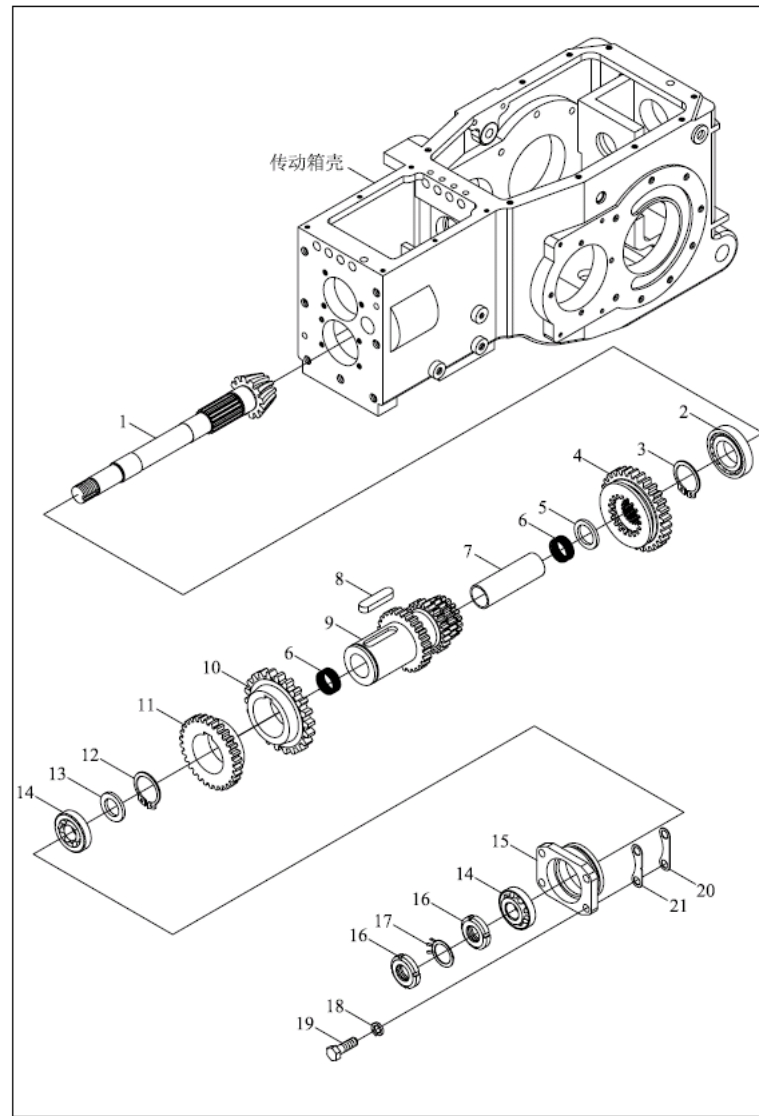

FT250.37C.001-2 37.2-传动箱总成-2 TRANSMISSION CASE ASSEMBLY-2

标号 No.	代号 Code	名称 Description		数量 Quantity	备注 Remark
1	FT250.37.102a	第二轴	II SHAFT	1	2011-08_
1	FT250.37.102	第二轴	II SHAFT	1	2004-01_
10	FT250.37.119	I 档从动齿轮	I DRIVEN GEAR	1	2011-11_
11	FT250.37.120	II 档从动齿轮	II DRIVEN GEAR	1	2011-11_
12	GBT894.1-55	轴用弹性挡圈	SNAP RING	1	2011-11_
13	FT250.37.110	二轴前止推环	SHAFT-2 FRONT THRUST RING	1	2004-01_
13	FT250.37.110a	二轴前止推环	SHAFT-2 FRONT THRUST RING	1	2011-08_
14	GBT297-31306	圆锥滚子轴承	BEARING	2	2011-11_
14	GBT297-31306	圆锥滚子轴承	BEARING	2	2011-11_
15	FT250.37.121	二轴前轴承座	SHAFT-2 FRONT BEARING SEAT	1	2011-11_
16	GBT812-M24X1.5	圆螺母	ROUND NUT	2	2011-11_
17	GBT858-24	圆螺母用止动垫圈	THRUST RING	1	2011-11_
18	GBT93-10-A0P	标准型弹簧垫圈	WASHER	4	2011-11_
19	GBT5783-M10X25-A2L	六角头螺栓	BOLT	4	2011-11_
2	TE250.371C-02	圆柱滚子轴承	BEARING	1	2011-08_
2	GBT283-NUP2207E	圆柱滚子轴承	BEARING	1	2004-01_
20	FT250.37.122	二轴调整垫片	SHAFT-2 ADJUSTING WASHER	999	2011-11_
21	FT250.37.123	二轴调整垫片	SHAFT-2 ADJUSTING WASHER	999	2011-11_
3	GBT894.1-34	轴用弹性挡圈	SNAP RING	1	2011-11_
4	FT250.37.103a	高低挡滑动齿轮	HIGH AND LOW GEAR SLIDING GEAR	1	2011-08_
4	FT250.37.103	高低挡滑动齿轮	HIGH AND LOW GEAR FIXING GEAR	1	2004-01_
5	FT250.37.104a	二轴后止推环	SHAFT-2 REAR THRUST RING	1	2011-08_
5	FT250.37.104	二轴后止推环	SHAFT-2 REAR THRUST RING	1	2004-01_
7	FT250.37.105	长隔套	LONG SPACER BUSH	1	2004-01_
7	FT250.37.105	长隔套	LONG SPACER BUSH	1	2004-01_

FT250.37C.001 传动箱总成-2

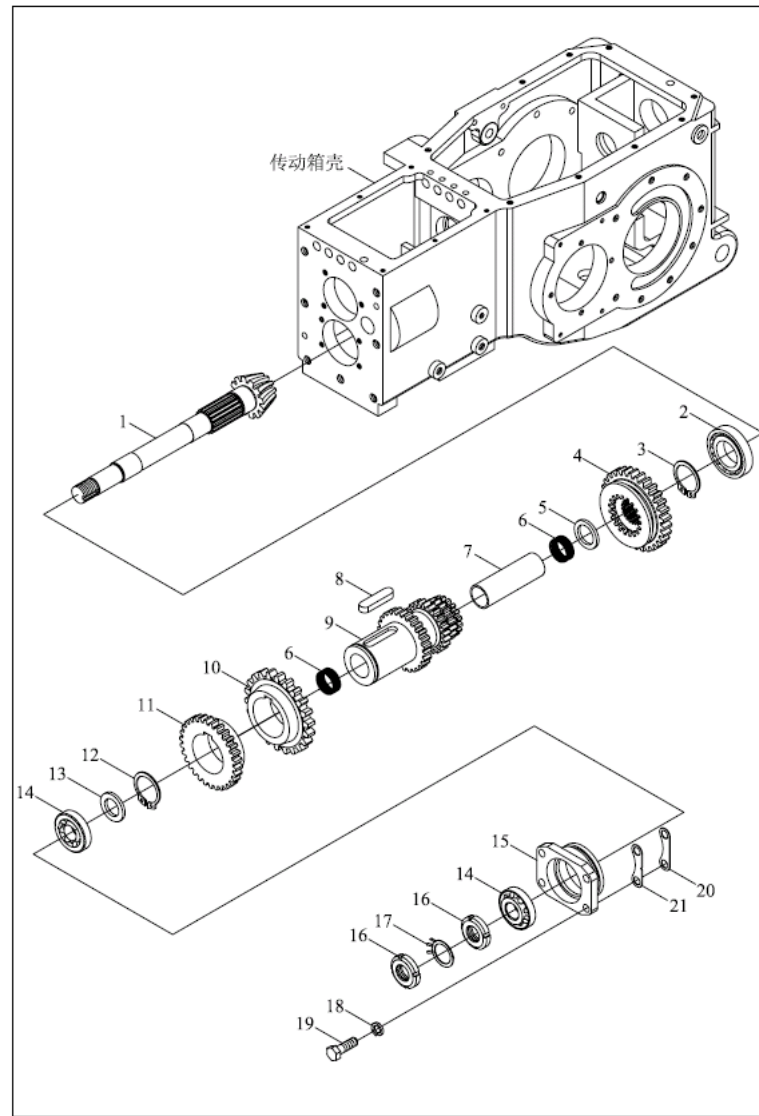

FT250.37C.001-2 37.2-传动箱总成-2(续)

标号 No.	代号 Code	名称 Description		数量 Quantity	备注 Remark
7	FT250.37.105a	长隔套	LONG SPACER BUSH	1	2011-08_
8	GBT1096-14X9X56	平键	FLAT KEY	1	2011-11_
9	FT250.37.106	Ⅲ-Ⅳ档从动齿轮	Ⅲ-Ⅳ DRIVEN GEAR	1	2004-01_
9	FT250.37.106a	Ⅲ-Ⅳ档从动齿轮	Ⅲ-Ⅳ DRIVEN GEAR	1	2011-08_

FT250.37C.001 传动箱总成-3

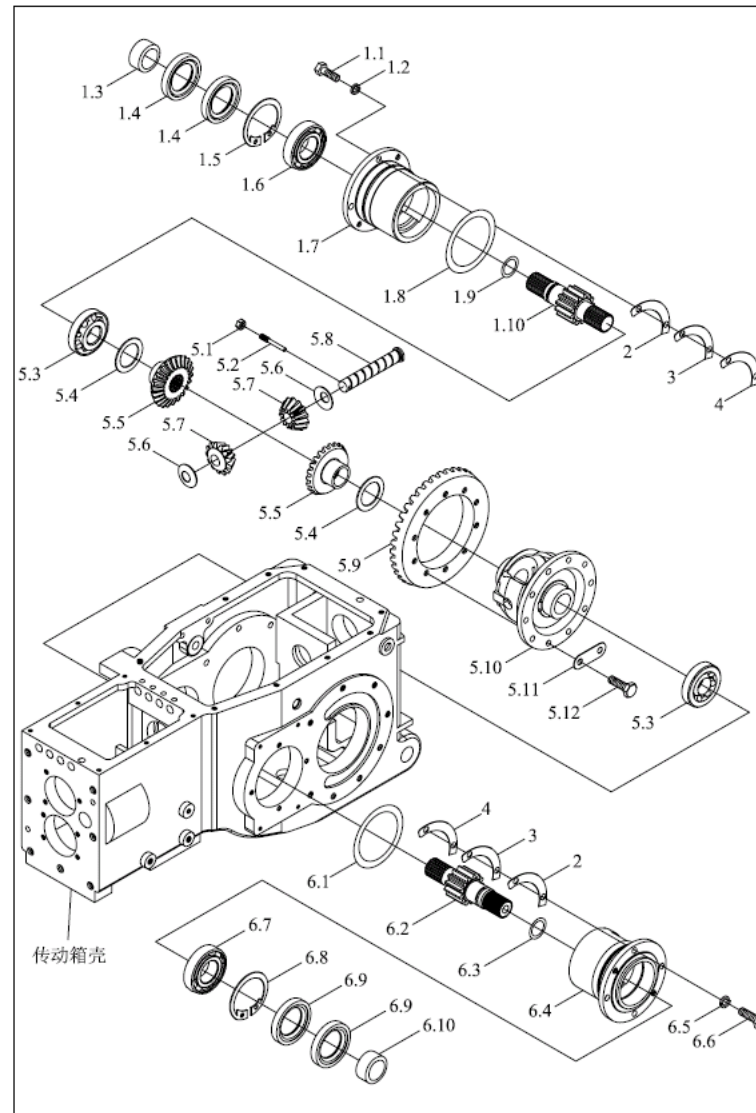

FT250.37C.001-3 37.3-传动箱总成-3 TRANSMISSION CASE ASSEMBLY-3

标号 No.	代号 Code	名称 Description		数量 Quantity	备注 Remark
1	FT250.37.023	右短半轴总成	RIGHT SHORT HALF SHAFT ASSEMBLY	1	2011-11_
1	FT250.37.023	右短半轴总成	RIGHT SHORT HALF SHAFT ASSEMBLY	1	2011-11_
1.1	GBT5783-M10X25-A3L	螺栓	BOLT	4	2011-11_
1.1	FT250.37.209	最终传动主动齿轮	FINAL TRANSMISSION DRIVING GEAR	1	2011-11_
1.2	GBT93-10-AOP	标准型弹簧垫圈	WASHER	4	2011-11_
1.3	FT250.37.208	油封套圈	OIL SEAL COLLAR	1	2011-11_
1.4	FT250.37.112	油封	OIL SEAL	2	2011-11_
1.5	GBT893.1-80	孔用挡圈	RETAINER RING FOR HOLE	1	2011-11_
1.6	GBT276-6307	深沟球轴承	BEARING	1	2011-11_
1.7	FT250.37.207	轴承座	BEARING SEAT	1	2011-11_
1.8	GBT3452.1-103X3.55G	液压气动用O形橡胶密封圈	O-SEAL RING	1	2011-11_
1.9	GBT3452.1-28X3.55G	液压气动用O形橡胶密封圈	O-SEAL RING	1	2011-11_
2	FT250.37.204	调整垫片	ADJUSTING WASHER	999	2011-11_
3	FT250.37.205	调整垫片	ADJUSTING WASHER	999	2011-11_
4	FT250.37.206	调整垫片	ADJUSTING WASHER	999	2011-11_
5	FT250.37.013	差速器总成	DIFFERENTIAL ASSEMBLY	1	2011-11_
5.1	GBT6170-M8-A2L	螺母	NUT	1	2011-11_
5.1	FT250.37.197	差速器壳	DIFFERENTIAL HOUSING	1	2011-11_
5.11	FT250.37.195	锁片	LOCK SHIM	5	2011-11_
5.12	GBT5786-M10X1.25X25-A2L	六角头螺栓	BOLT	10	2011-11_
5.2	FT250.37.201	固定螺钉	FIXING SCREW	1	2011-11_
5.3	GBT297-32011	圆锥滚子轴承	BEARING	2	2011-11_
5.4	FT250.37.203	半轴齿轮垫片	HALF SHAFT GEAR WASHER	2	2011-11_
5.5	FT250.37.202	半轴齿轮	HALF SHAFT GEAR	2	2011-11_
5.6	FT250.37.199	行星齿轮垫片	PLANET GEAR WASHER	2	2011-11_

FT250.37C.001 传动箱总成-3

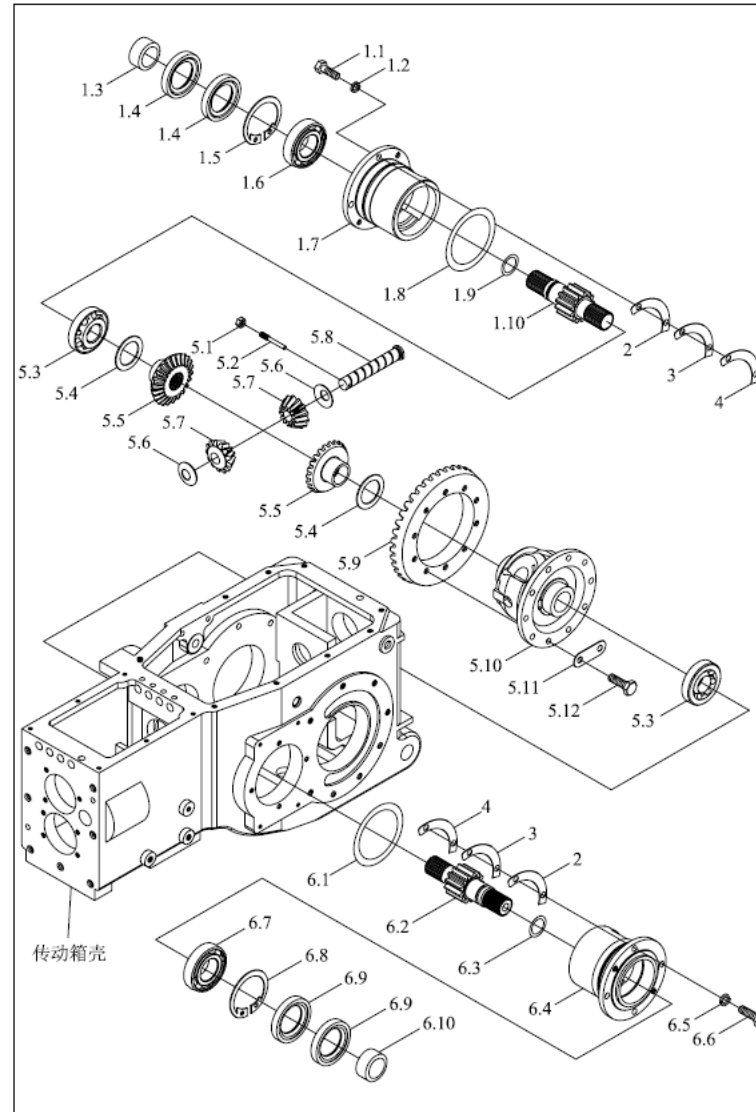

FT250.37C.001-3 37.3-传动箱总成-3(续)

标号 No.	代号 Code	名称 Description		数量 Quantity	备注 Remark
5.7	FT250.37.200	行星齿轮	PLANETARY GEAR	2	2011-11_
5.8	FT250.37.198	行星齿轮轴	PLANET GEAR SHAFT	1	2011-11_
5.9	FT250.37.196	从动螺旋锥齿轮	DRIVEN SPIRAL BEVEL GEAR	1	2011-11_
6	FT250.37.022	左短半轴总成	LEFT SHORT HALF SHAFT ASSEMBLY	1	2011-11_
6.1	GBT3452.1-103X3.55G	液压气动用O形橡胶密封圈	O-SEAL RING	1	2011-11_
6.1	FT250.37.208	油封套圈	OIL SEAL COLLAR	1	2011-11_
6.2	FT250.37.209	最终传动主动齿轮	FINAL TRANSMISSION DRIVING GEAR	1	2011-11_
6.3	GBT3452.1-28X3.55G	液压气动用O形橡胶密封圈	O-SEAL RING	1	2011-11_
6.4	FT250.37.207	轴承座	BEARING SEAT	1	2011-11_
6.5	GBT93-10-AOP	标准型弹簧垫圈	WASHER	4	2011-11_
6.6	GBT5783-M10X25-A3L	螺栓	BOLT	4	2011-11_
6.7	GBT276-6307	深沟球轴承	BEARING	1	2011-11_
6.8	GBT893.1-80	孔用挡圈	RETAINER RING FOR HOLE	1	2011-11_
6.9	FT250.37.112	油封	OIL SEAL	2	2011-11_

FT250.37C.001 传动箱总成-4

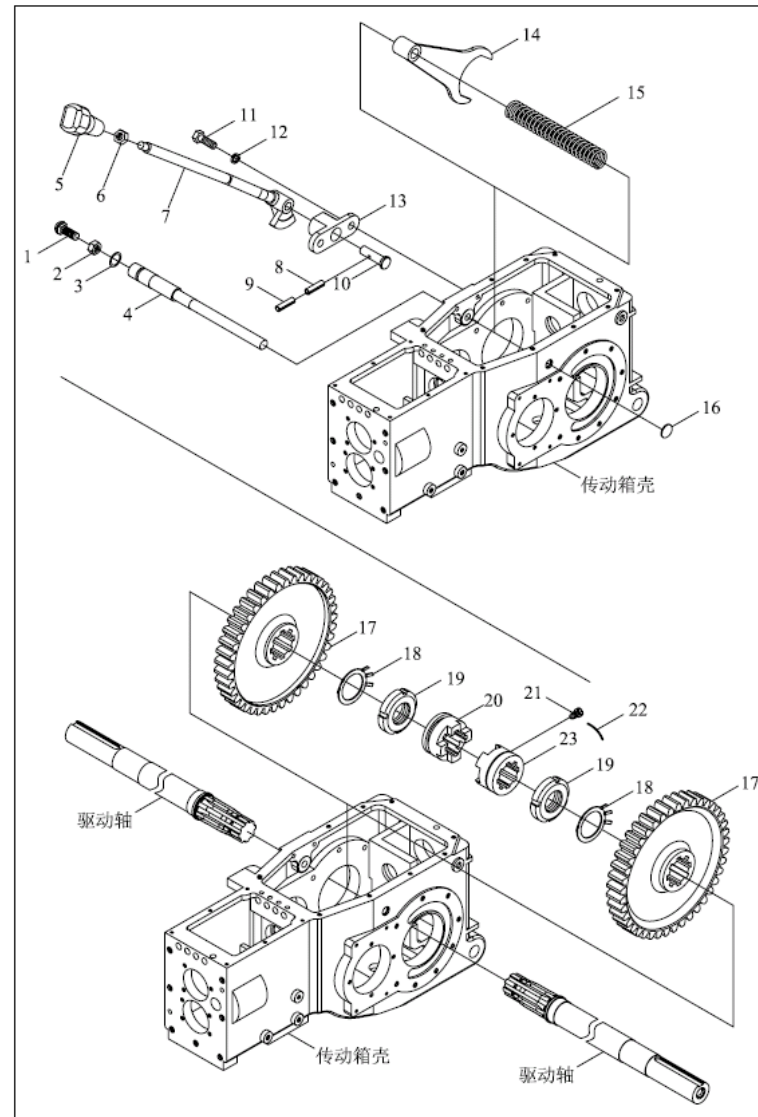

FT250.37C.001-4 37.4-传动箱总成-4 TRANSMISSION CASE ASSEMBLY-4

标号 No.	代号 Code	名称 Description		数量 Quantity	备注 Remark
1	FT250.37.323	球头螺栓	BALL BOLT	1	2011-11_
10	FT250.37.322	销轴	PIN	1	2011-11_
11	GBT93-10-A0P	标准型弹簧垫圈	WASHER	2	2004-01_
11	GBT5783-M10X25-A2L	六角头螺栓	BOLT	2	2004-01_
13	FT250.37.320	固定座	FIXING SEAT	1	2011-11_
14	FT250.37.262	差速锁拨叉	DIFFERENTIAL LOCK FORK	1	2011-11_
15	FT250.37.263	差速锁弹簧	DIFFERENTIAL LOCK SPRING	1	2011-11_
16	FT250.37.232	堵片	PLIUG PIECE	1	2011-11_
17	FT250.37.210	最终传动从动齿轮	FINAL TRANSMISSION DRIVEN GEAR	2	2011-11_
2	GBT6172.1-M10-A3L	螺母	NUT	1	2004-01_
20	FT250.37.261	右牙嵌	RIGHT JAW	1	2011-11_
21	FT250.37.264	锁紧螺钉	LOCKING NUT	1	2011-11_
22	TF1004.374-02	低碳钢丝	LOW CARBON STEEL WIRE	1	2011-11_
23	FT250.37.265	左牙嵌	LEFT JAW	1	2011-11_
3	GBT3452.1-15X2.65G	液压气动用O形橡胶密封圈	O-SEAL RING	1	2004-01_
4	FT250.37.267	差速锁拨叉轴	DIFFERENTIAL LOCK FORK SHAFT	1	2011-11_
5	FT250.41.011	动力输出分离操纵手柄	PTO RELEASE CONTROL HANDLE	1	2011-11_
6	GBT6170-M10-A3L	螺母	NUT	1	2004-01_
7	FT250.37.050	差速锁操纵杆焊合	DIFFERENTIAL LOCK CONTROL ROD WELDMENT	1	2011-11_

FT250.37C.001 传动箱总成-5

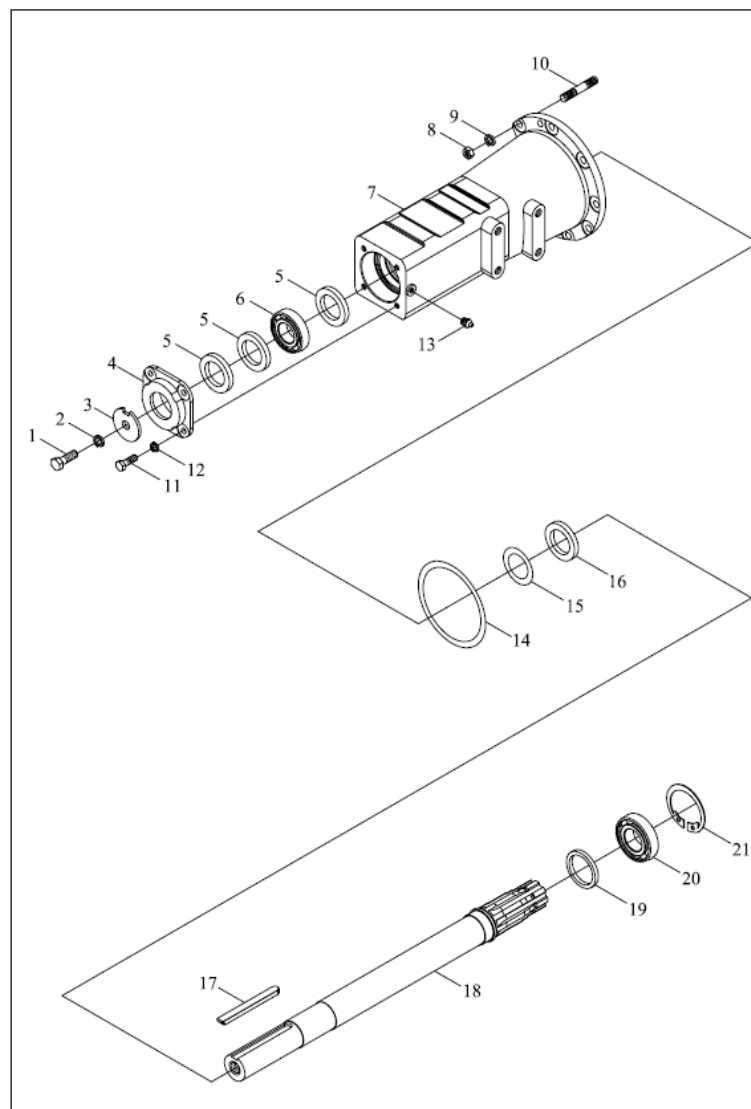

FT250.37C.001-5 37.5-传动箱总成-5 TRANSMISSION CASE ASSEMBLY-5

标号 No.	代号 Code	名称 Description		数量 Quantity	备注 Remark
0	FT250.37B.029	左半轴总成	LEFT HALF SHAFT ASSEMBLY	1	2011-11_
1	GBT5783-M16X35-Zn.D	六角头螺栓	BOLT	1	2011-11_
10	GBT898-AM12-M12X1.25X30-Zn.D	双头螺柱	8.8-A3L STUD	8	2011-11_
11	GBT5783-M10X25-Zn.D	六角头螺栓	BOLT	4	2011-11_
12	GBT93-10-Zn.D	标准型弹簧垫圈	WASHER	4	2011-11_
13	JBT7940.1-M10X1	直通式压注油杯	STRAIGHT PRESSURE FILLING OIL CUP	1	2011-11_
14	GBT3452.1-112X3.55G	液压气动用O形橡胶密封圈	O-SEAL RING	1	2011-11_
15	FT250.37.242	油封隔圈	OIL SEAL SPACER RING	1	2011-11_
16	GBT3452.1-B55X75X8	液压气动用O形橡胶密封圈	O-SEAL RING	1	2011-11_
17	FT250.37.215	平键	FLAT KEY	1	2011-11_
18	FT250.37B.212	驱动轴	DRIVING SHAFT	1	2011-11_
19	FT250.37.218	轴承挡圈	BEARING RETAINER RING	1	2011-11_
2	GBT93-16-Zn.D	标准型弹簧垫圈	WASHER	1	2011-11_
20	GBT276-6211	深沟球轴承	BEARING	1	2011-11_
21	GBT893.1-100	孔用弹性挡圈	SNAP RING	1	2011-11_
3	FT250.37.216	挡圈	RETAINER RING	1	2011-11_
4	FT250.37.214	驱动轴轴承盖	DRIVING SHAFT BEARING COVER	1	2011-11_
5	GBT9877.1-B50X72X8	内包骨架旋转轴唇形密封	O RING	3	2011-11_
6	GBT276-6210	深沟球轴承	BEARING	1	2011-11_
7	FT250.37B.226	左驱动轴套管	LEFT DRIVING SHAFT SLEEVE	1	2011-11_
8	GBT6171-M12X1.5-Zn.D	1型六角螺母	NUT	8	2011-11_
9	GBT93-12-Zn.D	标准型弹簧垫圈	WASHER	8	2011-11_

FT250.37C.001 传动箱总成-6

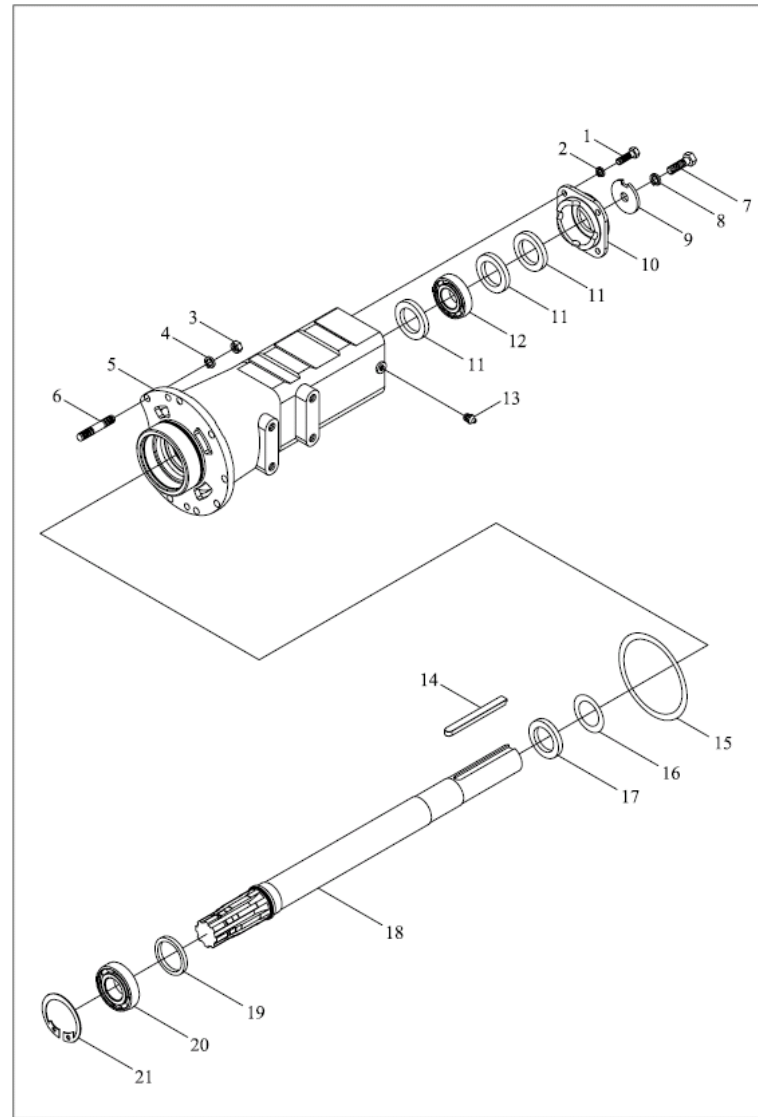

FT250.37C.001-6 37.6-传动箱总成-6 TRANSMISSION CASE ASSEMBLY-6

标号 No.	代号 Code	名称 Description		数量 Quantity	备注 Remark
0	FT250.37B.028	右半轴总成	RIGHT HALF SHAFT ASSEMBLY	1	2011-11_
1	GBT5783-M10X25-Zn.D	六角头螺栓	BOLT	4	2011-11_
10	FT250.37.214	驱动轴轴承盖	DRIVING SHAFT BEARING COVER	1	2011-11_
11	GBT9877.1-B50X72X8	内包骨架旋转轴唇形密封	O RING	3	2011-11_
12	GBT276-6210	深沟球轴承	BEARING	1	2011-11_
13	JBT7940.1-M10X1	直通式压注油杯	STRAIGHT PRESSURE FILLING OIL CUP	1	2011-11_
14	FT250.37.215	平键	FLAT KEY	1	2011-11_
15	GBT3452.1-112X3.55G	液压气动用O形橡胶密封圈	O-SEAL RING	1	2011-11_
16	FT250.37.242	油封隔圈	OIL SEAL SPACER RING	1	2011-11_
17	GBT9877.1-B55X75X8	内包骨架旋转轴唇形密封	O RING	1	2011-11_
18	FT250.37B.212	驱动轴	DRIVING SHAFT	1	2011-11_
19	FT250.37.218	轴承挡圈	BEARING RETAINER RING	1	2011-11_
2	GBT93-10-Zn.D	标准型弹簧垫圈	WASHER	4	2011-11_
20	GBT276-6211	深沟球轴承	BEARING	1	2011-11_
21	GBT893.1-100	孔用弹性挡圈	SNAP RING	1	2011-11_
3	GBT6171-M12X1.5-Zn.D	1型六角螺母	NUT	8	2011-11_
4	GBT93-12-Zn.D	标准型弹簧垫圈	WASHER	8	2011-11_
5	FT250.37B.217	右驱动轴套管	RIGHT DRIVING SHAFT SLEEVE	1	2011-11_
6	GBT898-AM12-M12X1.25X30-Zn.D	双头螺柱	8.8-A3L STUD	8	2011-11_
7	GBT5783-M16X35	螺栓 M16*35	BOLT	1	2004-01_
8	GBT93-16-Zn.D	标准型弹簧垫圈	WASHER	1	2011-11_
9	FT250.37.216	挡圈	RETAINER RING	1	2011-11_

FT250.37C.001 传动箱总成-7.1

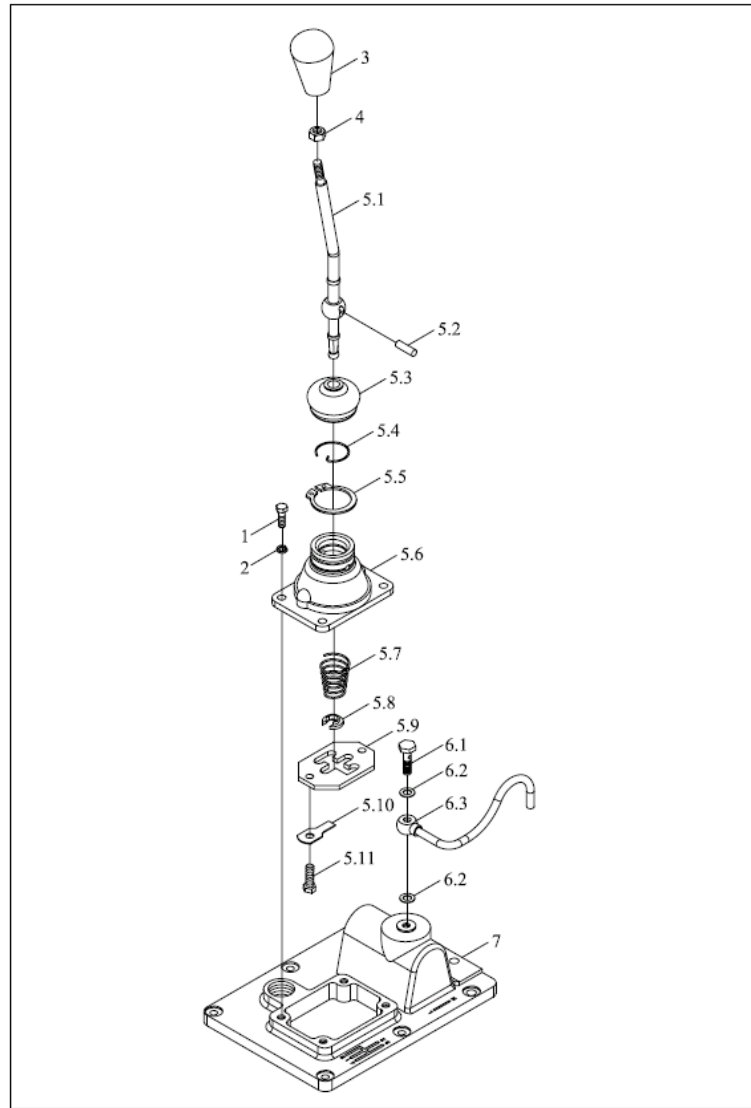

FT250.37C.001-7.1 37.7.1-传动箱总成-7.1 TRANSMISSION CASE ASSEMBLY-7.1

标号 No.	代号 Code	名称 Description		数量 Quantity	备注 Remark
0	FT250.37.016	变速箱盖总成	GEAR BOX COVER ASSEMBLY	1	2011-11_
1	GBT5783-M8X25-A2L	螺栓	BOLT	4	2011-11_
2	GBT93-8-A0P	垫圈	WASHER	4	2011-11_
3	FT250.37.040	主变速操纵手柄	MAIN GEARSHIFT CONTROL HANDLE	1	2011-11_
4	GBT6170-M10-A3L	螺母	NUT	1	2011-11_
5	FT250.37.019	主变速杆总成	MAIN GEARLEVER ASSEMBLY	1	2011-11_
5.1	FT250.37.180	变速杆	GEARLEVER	1	2011-11_
5.2	GBT119.1-D6X42	圆柱销	PIN	1	2011-11_
5.2	GBT119.1-D6X42	圆柱销	PIN	1	2011-11_
5.3	FT250.37.181	变速杆密封罩	GEARLEVER SEAL HOOD	1	2011-11_
5.4	FT250.37.248	钢丝挡圈	SNAP RING	1	2011-11_
5.5	GBT894.1-45	挡圈	RETAINER RING	1	2011-11_
5.6	FT250.37.211	主变速杆座	MAIN GEARLEVER SEAT	1	2011-11_
5.7	FT250.37.183	变速杆弹簧	GEARLEVER SPRING	1	2011-11_
5.7	FT250.37.183	变速杆弹簧	GEARLEVER SPRING	1	2011-11_
5.8	FT300.37.164	变速杆弹簧挡圈	GEARLEVER SPRING RETAINER RING	1	2011-11_
5.9	FT250.37.185	变速杆导板	GEARLEVER GUIDE BOARD	1	2011-11_
6	FT250.37.031a	呼吸器总成		1	2011-11_
6.1	FT250.37.402	空心螺栓	HOLLOW BOLT	1	2011-11_
6.2	JBT982-8	组合垫圈	COMBINED GASKET	2	2011-11_
6.3	FT250.37.061	呼吸硬管总成	BREATHING PIPE ASSEMBLY	1	2011-11_
7	FT250.37.182a	变速箱盖	GEARBOX COVER	1	2011-11_

FT250.37C.001 传动箱总成-7.2

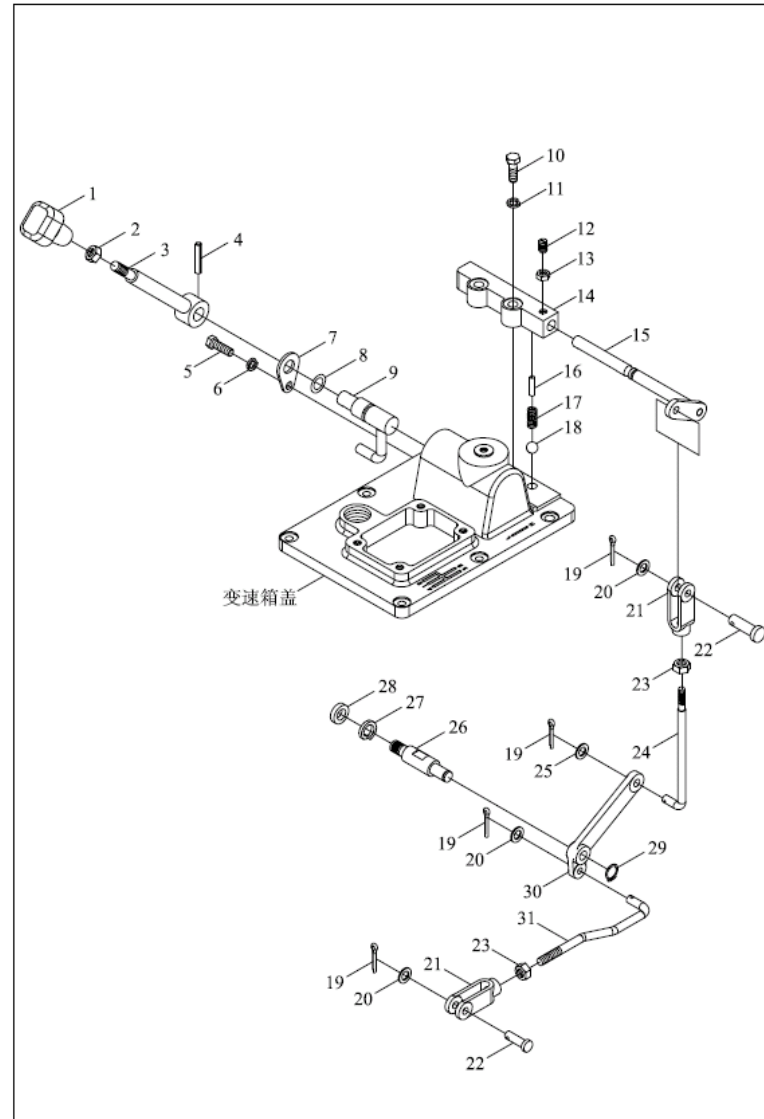

FT250.37C.001-7.2 37.7.2-传动箱总成-7.2 TRANSMISSION CASE ASSEMBLY-7.2

标号 No.	代号 Code	名称 Description		数量 Quantity	备注 Remark
0	FT250.37.016	变速箱盖总成	GEAR BOX COVER ASSEMBLY	1	2011-11_
1	FT250.37.037	副变速操纵手柄	AUXILIARY GEARSHIFT CONTROL HANDLE	1	2011-11_
10	GBT5783-M10X40-A3L	螺栓	BOLT	2	2011-11_
11	GBT93-10-A0P	标准型弹簧垫圈	WASHER	2	2011-11_
12	FT250.37.249	固定螺钉	FIXING SCREW	1	2011-11_
13	GBT6173-M8X1-A2L	1型六角螺母	NUT		2011-01_
14	FT250.37.254	联锁压座	INTERLOCKING PRESS SEAT	1	2011-11_
15	FT250.37.027	联锁轴焊合	INTERLOCKING SHAFT WELDMENT	1	2011-11_
16	FT250.37.250	固定销	FIXING PIN	4	2011-11_
17	FT250.37.148	拨叉轴锁定弹簧	FORK SHAFT LOCKING SPRING	4	2011-11_
17	FT250.37.148	拨叉轴锁定弹簧	FORK SHAFT LOCKING SPRING	4	2011-11_
18	GBT308-8.7321-G200-b	钢球	BALL	4	2011-11_
19	GBT91-3.2X20-A0P	开口销	PIN	4	2011-11_
19	GBT91-3.2X20-A0P	开口销	PIN	4	2011-11_
2	GBT6170-M10-A3L	螺母	NUT	1	2011-11_
20	GBT97.1-8-A0P	平垫圈	WASHER	3	2011-11_
21	FT250.43.103	制动拉杆调整叉	BRAKE PULL ROD ADJUSTING FORK	2	2011-11_
22	GBT6170-M8-A2L	螺母	NUT	2	2011-11_
23	GBT882-B8 × 28	销轴	PIN	2	2004-01_
24	FT250.37.328	拉杆 (二)	PULL ROD (2)	1	2011-11_
25	GBT97.1-10-A0P	平垫圈	WASHER	1	2011-11_
26	FT250.37.329	螺柱	STUD	1	2011-11_
27	GBT93-12	垫圈	WASHER	1	2011-11_
28	FT250.37.330	垫片	WASHER	1	2011-11_
29	GBT894.1-12	轴用弹性挡圈	SNAP RING	1	2011-11_

FT250.37C.001 传动箱总成-7.2

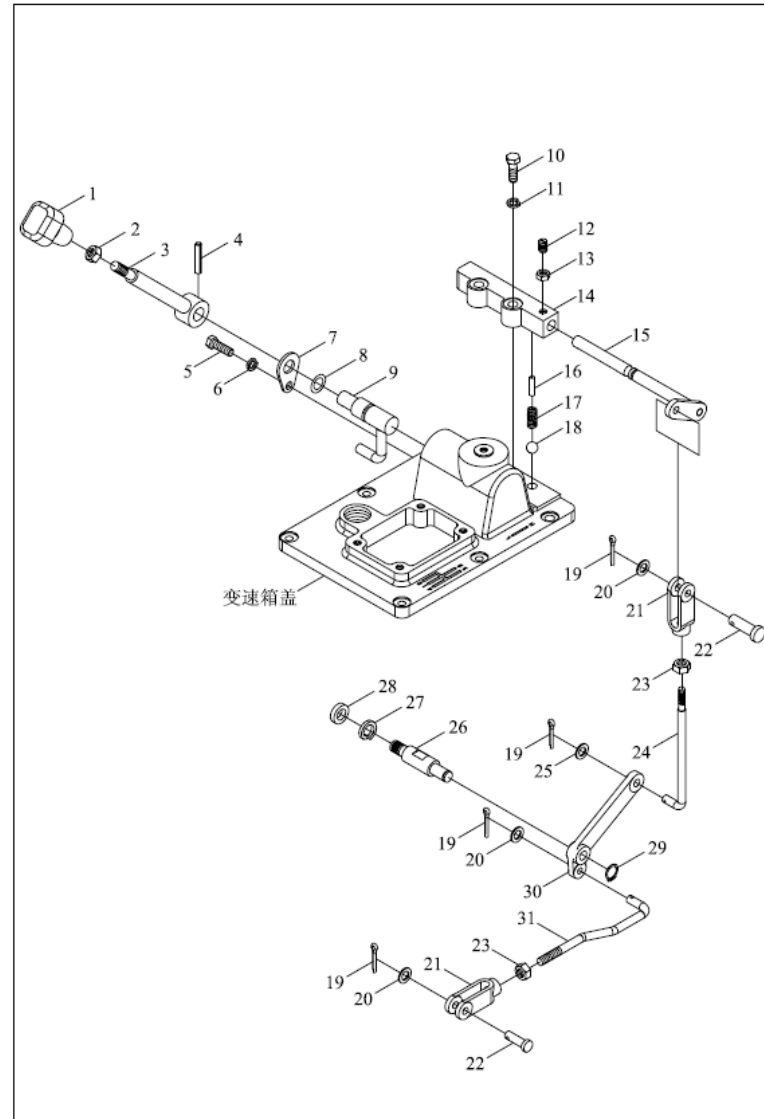

FT250.37C.001-7.2 37.7.2-传动箱总成-7.2(续)

标号 No.	代号 Code	名称 Description		数量 Quantity	备注 Remark
3	FT250.37.020	副变速操纵杆焊接	AUXILIARY GEARSHIFT CONTROL ROD	1	2011-11_
30	FT250.37.326	联锁杠杆	WELDMENT	1	2011-11_
31	FT250.37.327	拉杆(一)	INTERLOCKING LEVER	1	2011-11_
4	GBT879.1-5X30	弹性圆柱销	PULL ROD (1)	1	2011-11_
5	GBT5783-M8X20-A2L	螺栓	PIN BOLT	1	2011-11_
6	GBT93-8-A0P	垫圈		1	2011-11_
7	FT250.37.313	压板	WASHER	1	2011-11_
8	GBT3452.1-15X2.65G	液压气动用O形橡胶密封圈	PRESSURE PLATE	1	2011-11_
9	FT250.37.038	副变速拨杆总成	O-SEAL RING AUXILIARY DIAL ROD ASSEMBLY	1	2011-11_

FT250.37C.001 传动箱总成-8

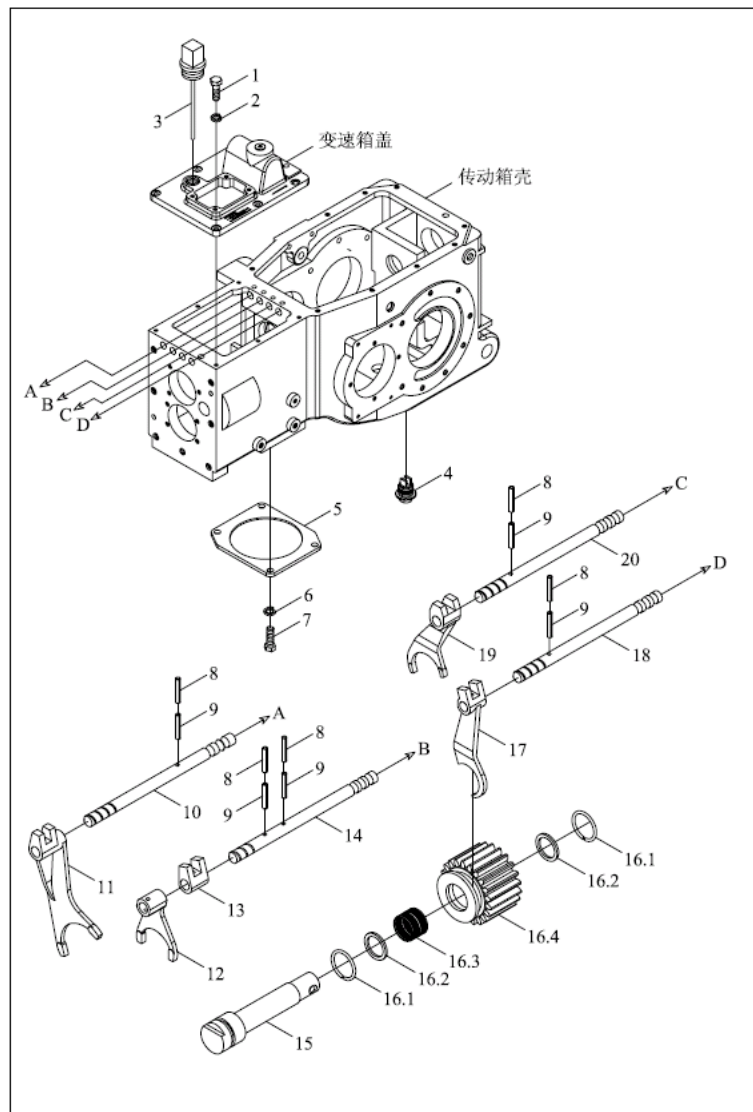

FT250.37C.001-8 37.8-传动箱总成-8 TRANSMISSION CASE ASSEMBLY-8

标号 No.	代号 Code	名称 Description		数量 Quantity	备注 Remark
1	GBT5783-M8X25-A2L	螺栓	BOLT	6	2011-11_
10	FT250.37.188	高低档拨叉轴	HIGH AND LOW GEAR FORK SHAFT	1	2011-11_
11	FT250.37.145	高低档拨叉	HIGH AND LOW GEAR FORK	1	2011-11_
12	FT250.37.143	Ⅲ-Ⅳ档拨叉	Ⅲ-Ⅳ FORK	1	2011-11_
13	FT250.37.142	Ⅲ-Ⅳ档拨头	Ⅲ-Ⅳ FORK HEAD	1	2011-11_
14	FT250.37.187	Ⅲ-Ⅳ档拨叉轴	Ⅲ-Ⅳ FORK SHAFT	1	2011-11_
15	FT250.37.111a	倒档轴	REVERSE SHAFT	1	2011-11_
15	FT250.37.111a	倒档轴	REVERSE SHAFT	1	2011-11_
16	FT250.37.012a	倒档齿轮总成	REVERSE GEAR ASSEMBLY	1	2011-11_
16.1	GBT895.1-26	轴用钢丝挡圈	SNAP RING	2	2011-11_
16.2	FT250.37.331	滚针隔套	NEEDLE SPACER BUSH	2	2011-11_
16.3	QSFZB019-K20X26X34ZW	滚针轴承	NEEDLE BEARINGS	1	2011-01_
16.4	FT250.37.108a	倒档齿轮	DRIVING AXLE ASSEMBLY	1	2011-11_
17	FT250.37.118	倒档拨叉	REVERSE FORK	1	2011-11_
18	FT250.37.190	倒档拨叉轴	REVERSE FORK SHAFT	1	2011-11_
19	FT250.37.131	I-II档拨叉	I-II GEAR FORK	1	2011-11_
2	GBT93-8-A0P	垫圈	WASHER	6	2011-11_
20	FT250.37.186	I-II档拨叉轴	I-II GEAR FORK SHAFT	1	2011-11_
3	FT250.37.030	油尺总成	DIPSTICK ASSEMBLY	1	2011-11_
4	FT65.38.026	油塞总成	Oil Plug assembly	1	2011-11_
4	FT65.38.026	油塞总成	Oil Plug assembly	1	2011-11_
5	FT250.37.237	分动箱口堵盖	TRANSFER CASE BLOCK COVER	1	2011-11_
6	GBT93-10-A0P	标准型弹簧垫圈	WASHER	4	2011-11_
7	GBT5783-M10X25-A2L	六角头螺栓	BOLT	4	2011-11_
8	GBT879.1-3X24	弹性圆柱销	PIN	5	2011-11_

FT250.37C.001 传动箱总成-8

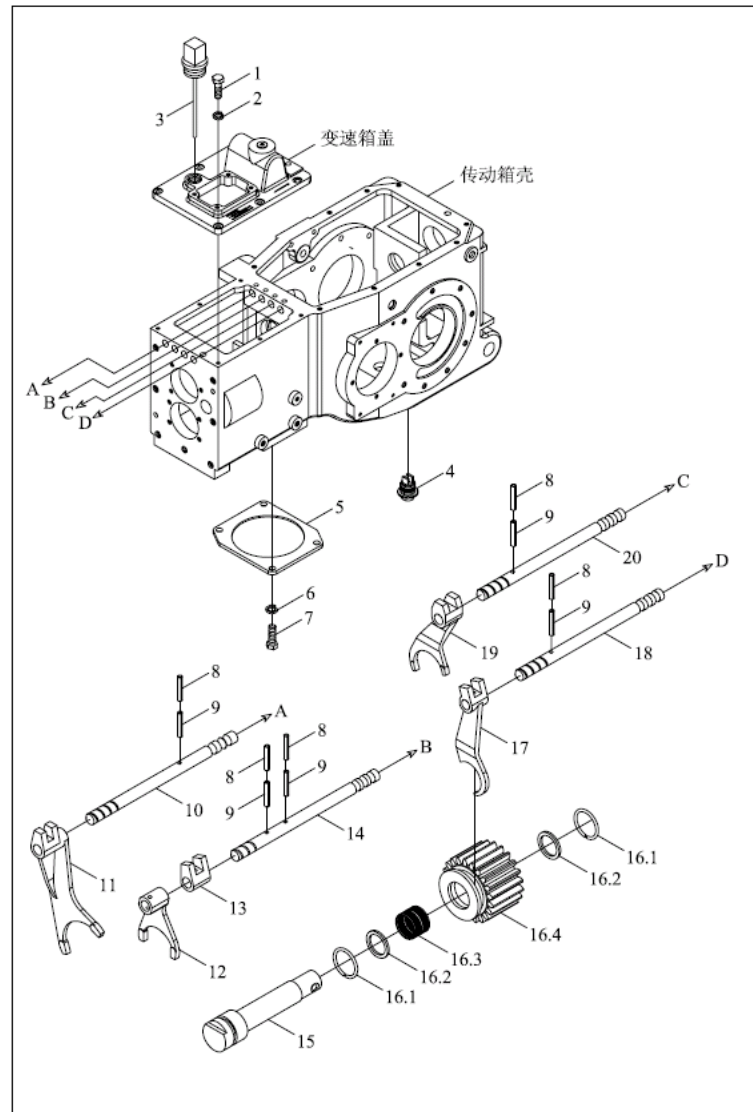

FT250.37C.001-8 37.8-传动箱总成-8(续)

标号 No.	代号 Code	名称 Description		数量 Quantity	备注 Remark
9	GBT879.1-5X24	弹性圆柱销	PIN	5	2011-11_

FT254.40.001 全液压转向总成-1

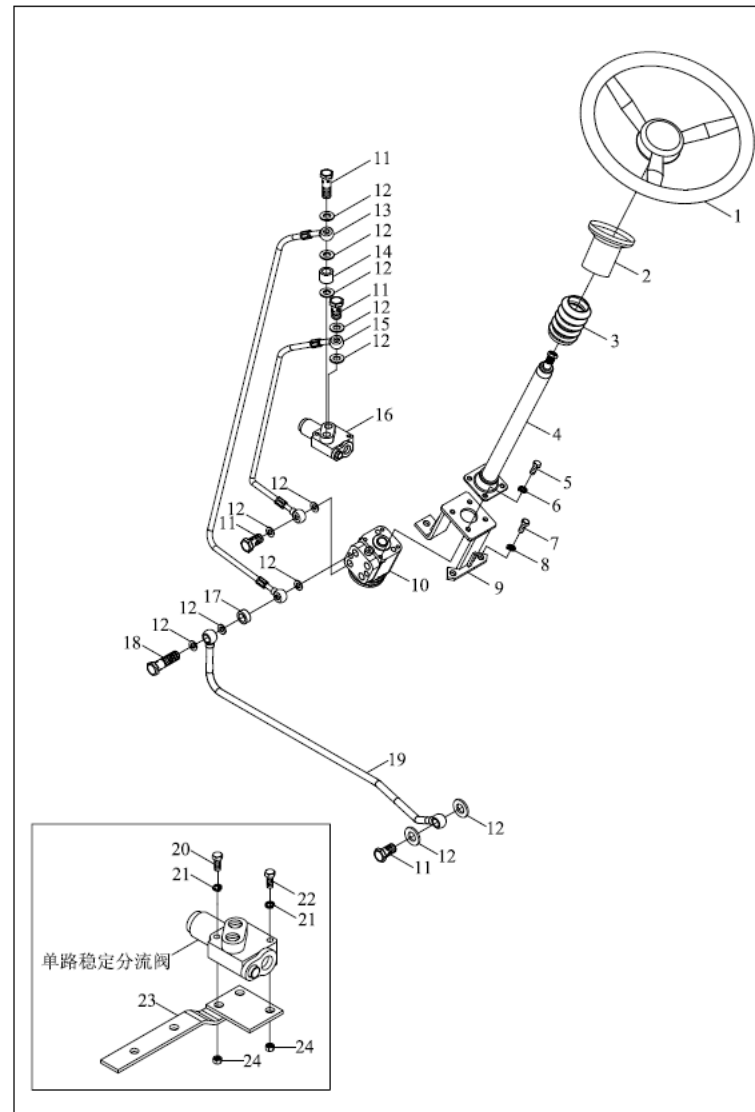

FT254.40.001-1 40.1-全液压转向总成-1 40FULL HYDRAULIC STEERING ASSEMBLY-1

标号 No.	代号 Code	名称 Description		数量 Quantity	备注 Remark
1	FT220.40.015	转向盘总成	STEERING WHEEL ASSEMBLY	1	2011-11_
10	FT254.40.028	液压转向器总成	HYDRAULIC STEERING MECHANISM ASSEMBLY	1	2011-11_
11	FT254.40.102	空心螺栓	HOLLOW BOLT	4	2011-11_
12	JB T982-20	组合密封垫圈	COMBINED SEAL GASKET	12	2011-11_
13	FT254.40.020	分流阀回油管总成	DIVERTER VALVE OIL RETURN PIPE ASSEMBLY	1	2011-11_
14	FT354.40C.108	短接管	SHORT CONNECTING PIPE	1	2011-11_
15	FT254.40.018	转向器进油管总成	REDIRECTOR OIL INLET PIPE ASSEMBLY	1	2011-11_
16	FT254.40.030	单路稳定分流阀	SINGLE-WAY STABILIZER DIVERTER VALVE	1	2011-11_
17	FT254.40.127	隔套	SPACER BUSH	1	2011-11_
18	FT254.40.106	空心螺栓	HOLLOW BOLT	1	2011-11_
19	FT254.40.031	回油管总成	OIL RETURN PIPE ASSEMBLY	1	2011-11_
2	FT650.40.014	喇叭电刷座总成	HORN BRUSH SEAT ASSEMBLY	1	2011-11_
20	GB T5782-M8X55	六角头螺栓	BOLT	1	2011-11_
21	GB T93-8	垫圈8	WASHER 8	3	2011-11_
22	GB T5782-M8X65	六角头螺栓	BOLT	2	2011-11_
23	FT254.40.013	分流阀支架焊合	DIVERTER VALVE BRACKET WELDMENT	1	2011-11_
24	GB T6170-M8	螺母M8	NUT M8	3	2011-11_
3	FT220.40.301	转向杆护套	STEERING ROD SLEEVE	1	2011-11_
4	FT254.40.029	转向管柱总成	STEERING PIPE COLUMN ASSEMBLY	1	2011-11_
5	GB T5781-M10X30	六角头螺栓全螺纹C级		4	2011-11_
6	GB T93-10	垫圈10	WASHER 10	4	2011-11_
8	GB T93-14	垫圈	WASHER	3	2011-11_
8	GB T93-14	垫圈	WASHER	3	2011-11_
9	FT254.40.011	转向器支架焊合	REDIRECTOR BRACKET WELDMENT	1	2011-11_

FT254.40.001 全液压转向总成-2

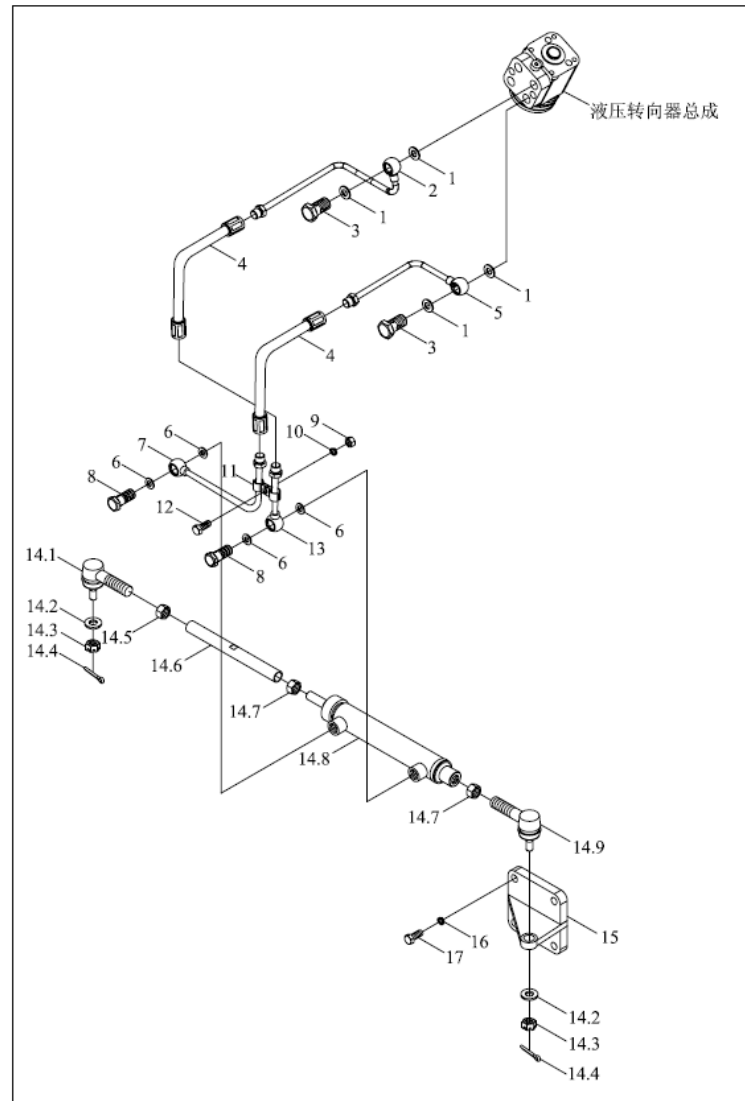

FT254.40.001-2 40.2-全液压转向总成-2 40FULL HYDRAULIC STEERING ASSEMBLY-2

标号 No.	代号 Code	名称 Description	数量 Quantity	备注 Remark
1	JBT982-20	组合密封垫圈	4	2011-11_
10	GBT93-8	垫圈8	1	2011-11_
11	FT254.40.128	双管夹	2	2011-11_
13	FT254.40.033	油缸左过渡管总成	1	2011-11_
13	FT254.40.033	油缸左过渡管总成	1	2011-11_
14	FT254.40.012	纵拉杆及转向油缸总成	1	2011-11_
14.1	FT254.40.027	拉杆总成接头(左)	1	2011-11_
14.3	GBT6181-14	六角开槽薄螺母	2	2011-11_
14.6	FT254.40.146	调节螺杆	1	2011-11_
14.7	GBT6173-M16X1.5	六角螺母	2	2011-11_
14.8	FT254.40.022	转向油缸	1	2011-11_
14.9	FT254.40.026	拉杆接头总成(右)	1	2011-11_
15	FT254.40.101	油缸支座	1	2011-11_
16	GBT93-14	垫圈	4	2011-11_
16	GBT93-14	垫圈	4	2011-11_
2	FT254.40.016	油缸左导管总成	1	2011-11_
3	FT254.40.102	空心螺栓	2	2011-11_
4	FT254.40.015	油缸软管总成	2	2011-11_
5	FT254.40.017	油缸右导管总成	1	2011-11_
6	JBT982-14	组合密封垫圈	4	2011-11_
6	JBT982-14	组合密封垫圈	4	2011-11_
7	FT254.40.032	油缸右过渡管总成	1	2011-11_
8	FT354.40E.172	空心螺栓	2	2011-11_
9	GBT6170-M8	螺母M8	1	2011-11_

FT250.41A.001 动力输出总成-1

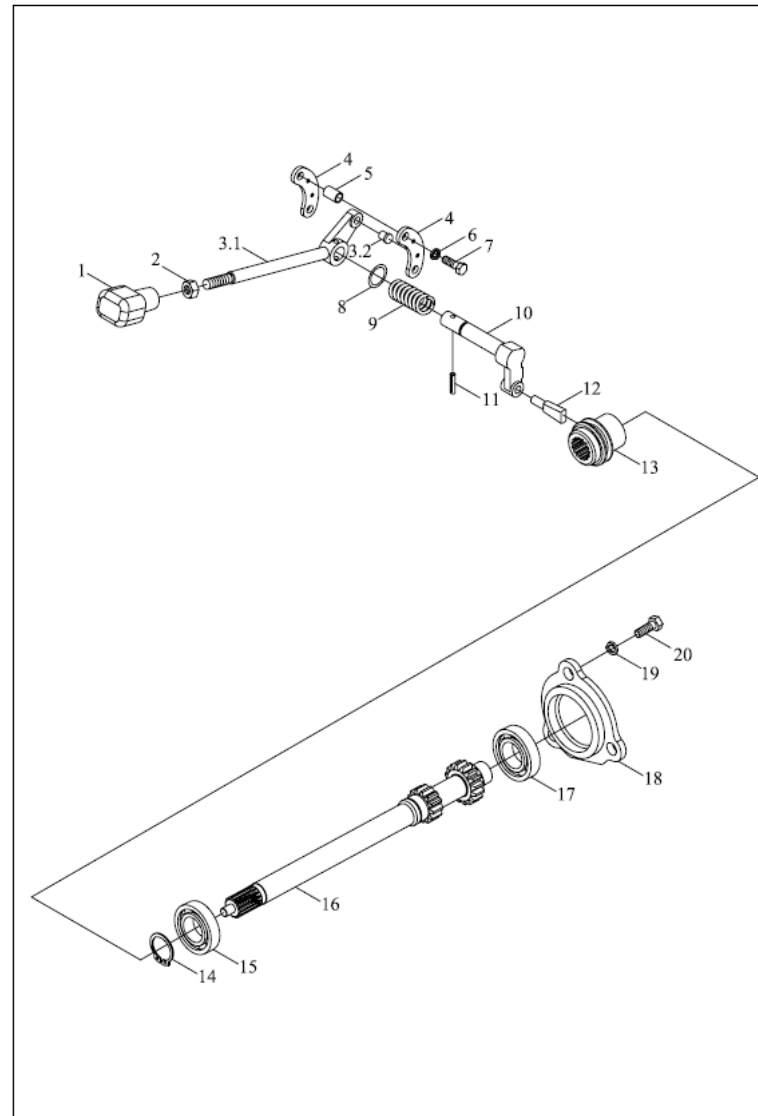

FT250.41A.001-1 41.1-动力输出总成-1 POWER TAKE-OFF ASSEMBLY-1

标号 No.	代号 Code	名称 Description		数量 Quantity	备注 Remark
1	FT250.41.011	动力输出分离操纵手柄	PTO RELEASE CONTROL HANDLE	1	2011-11_
10	FT250.41.110	动力输出拨叉轴	PTO FORK SHAFT	1	2011-11_
11	GBT879-5X24	销	PIN	1	2011-11_
12	FT250.41.109	动力输出轴拨叉头	PTO SHAFT FORK HEAD	1	2011-11_
13	FT250.41.101	花键套	SPLINE BUSH	1	2011-11_
14	GBT894.1-30	挡圈	RETAINER RING	1	2011-11_
15	GBT276-6006	轴承	BEARING	1	2011-11_
16	FT250.41A.102	动力输出传动轴	PTO TRANSMISSION SHAFT	1	2011-11_
17	GBT276-6006	轴承	BEARING	1	2011-11_
18	FT250.41.103	传动轴轴承盖	TRANSMISSION SHAFT BEARING COVER	1	2011-11_
19	GBT93-10-A0P	标准型弹簧垫圈	WASHER	3	2011-11_
2	GBT6170-M10-A2L	螺母	NUT	1	2011-11_
20	GBT5783-M10X25-A2L	六角头螺栓	BOLT	3	2011-11_
3	FT250.41.012	分离杆及销总成	RELEASE ROD AND PIN ASSEMBLY	1	2011-11_
3.1	FT250.41.017	分离杆总成	RELEASE ROD ASSEMBLY	1	2011-11_
3.1	FT250.41.017	分离杆总成	RELEASE ROD ASSEMBLY	1	2011-11_
3.2	FT250.41.128	限位销	LIMITING PIN	1	2011-11_
4	FT250.41.112	分离杆定位片	RELEASE ROD FIXING PIECE	2	2011-11_
5	FT250.41.111	隔套	SPACER BUSH	2	2011-11_
6	GBT93-8-A0P	垫圈	WASHER	2	2011-11_
7	GBT5781-M8X35-A2L	六角头螺栓	BOLT	2	2011-11_
8	GBT3452.1-11.8X1.8G	液压气动用O形橡胶密封圈	O-SEAL RING	1	2011-11_
9	FT250.41.114	分离杆弹簧	RELEASE ROD SPRING	1	2011-11_
9	FT250.41.114	分离杆弹簧	RELEASE ROD SPRING	1	2011-11_

FT250.41A.001 动力输出总成-2

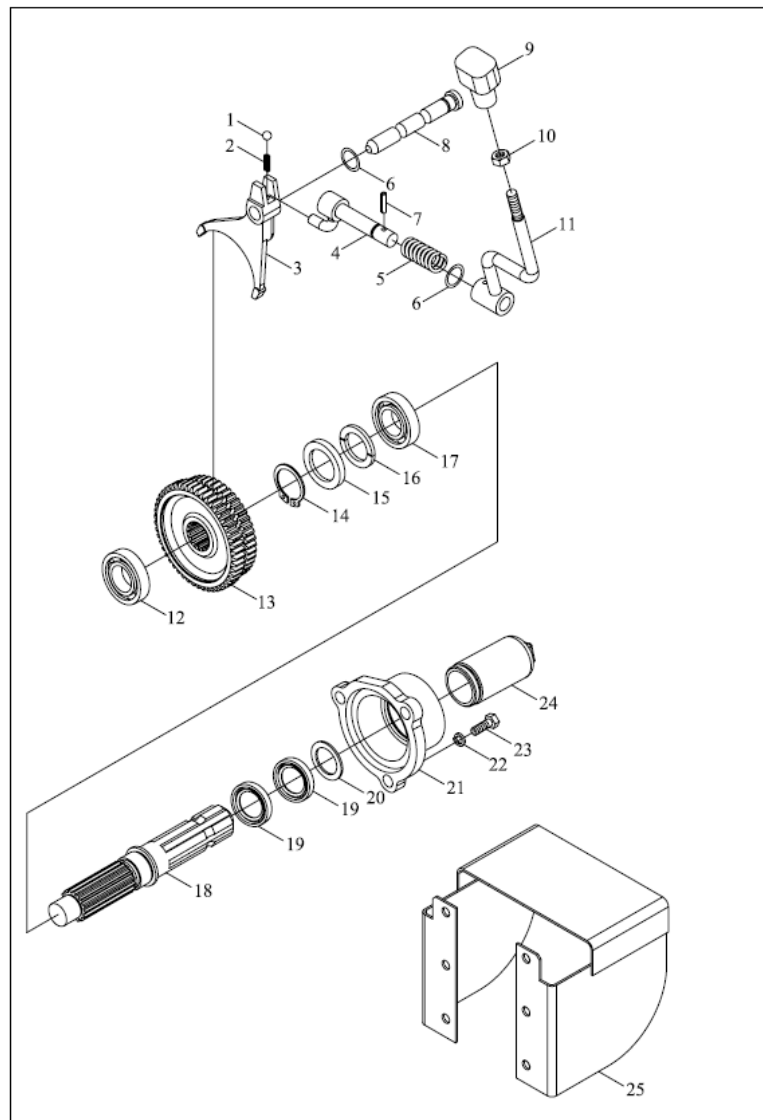

FT250.41A.001-2 41.2-动力输出总成-2 POWER TAKE-OFF ASSEMBLY-2

标号 No.	代号 Code	名称 Description		数量 Quantity	备注 Remark
10	GBT6170-M10-A2L	螺母	NUT	1	2011-11_
11	FT250.41.014	动力输出换挡操纵杆焊接	PTO GEARSHIFT CONTROL ROD WELDMENT	1	2011-11_
12	GBT276-6305	轴承	BEARING	1	2011-11_
13	FT250.41A.108	动力输出从动齿轮	PTO DRIVEN GEAR	1	2011-11_
13	FT250.41A.108	动力输出从动齿轮	PTO DRIVEN GEAR	1	2011-11_
14	GBT894.1-34	轴用弹性挡圈	SNAP RING	1	2011-11_
15	FT250.41.132	止推片挡环	THRUST WASHER RETAINER RING	1	2011-11_
16	FT250.41.131	止推片	THRUST SHIM	1	2011-11_
17	GBT276-6207	轴承	BEARING	1	2011-11_
18	FT250.41.106	动力输出轴	PTO SHAFT	1	2011-11_
19	GBT9877.1-FB35X55X8	内包骨架旋转轴唇形密封	O RING	2	2011-11_
2	FT250.37.148	拨叉轴锁定弹簧	FORK SHAFT LOCKING SPRING	1	2011-11_
2	FT250.37.148	拨叉轴锁定弹簧	FORK SHAFT LOCKING SPRING	1	2011-11_
20	FT250.41.133	垫片	WASHER	1	2011-11_
21	FT250.41.104	动力输出轴轴承盖	PTO SHAFT BEARING COVER	1	2011-11_
22	GBT93-10-A0P	标准型弹簧垫圈	WASHER	3	2011-11_
23	GBT5783-M10X25-A2L	六角头螺栓	BOLT	3	2011-11_
24	FT250.41.107	动力输出轴护罩	PTO SHAFT HOOD	1	2011-11_
25	FT250.41.018a	动力输出防护罩焊接	PTO BONNET WELDMENT	1	2011-11_
3	FT250.41.115	动力输出换挡拨叉	PTO GEARSHIFT FORK	1	2011-11_
4	FT250.41.013	动力输出换挡拨杆总成	PTO GEARSHIFT DIAL ROD ASSEMBLY	1	2011-11_
5	FT250.41.114	分离杆弹簧	RELEASE ROD SPRING	1	2011-11_
5	FT250.41.114	分离杆弹簧	RELEASE ROD SPRING	1	2011-11_
6	GBT3452.1-11.8X1.8G	液压气动用O形橡胶密封圈	O-SEAL RING	2	2011-11_
7	GBT879-5X24	销	PIN	1	2011-11_

FT250.41A.001 动力输出总成-2

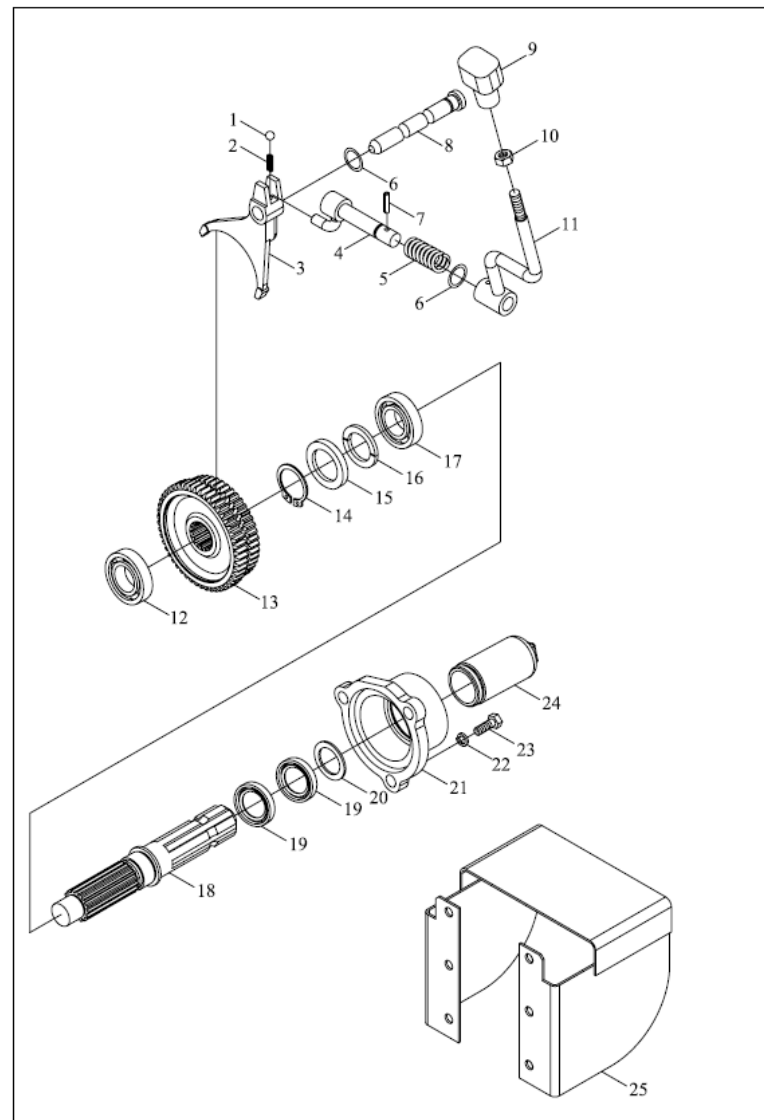

FT250.41A.001-2 41.2-动力输出总成-2(续)

标号 No.	代号 Code	名称 Description		数量 Quantity	备注 Remark
8	FT250.41.116	动力输出换挡拨叉轴	PTO GEARSHIFT FORK SHAFT	1	2011-11_
8	FT250.41.116	动力输出换挡拨叉轴	PTO GEARSHIFT FORK SHAFT	1	2011-11_
9	FT250.41.016	动力输出换挡手柄	PTO GEARSHIFT HANDLE	1	2011-11_

FT254.42.001 分动箱总成-1

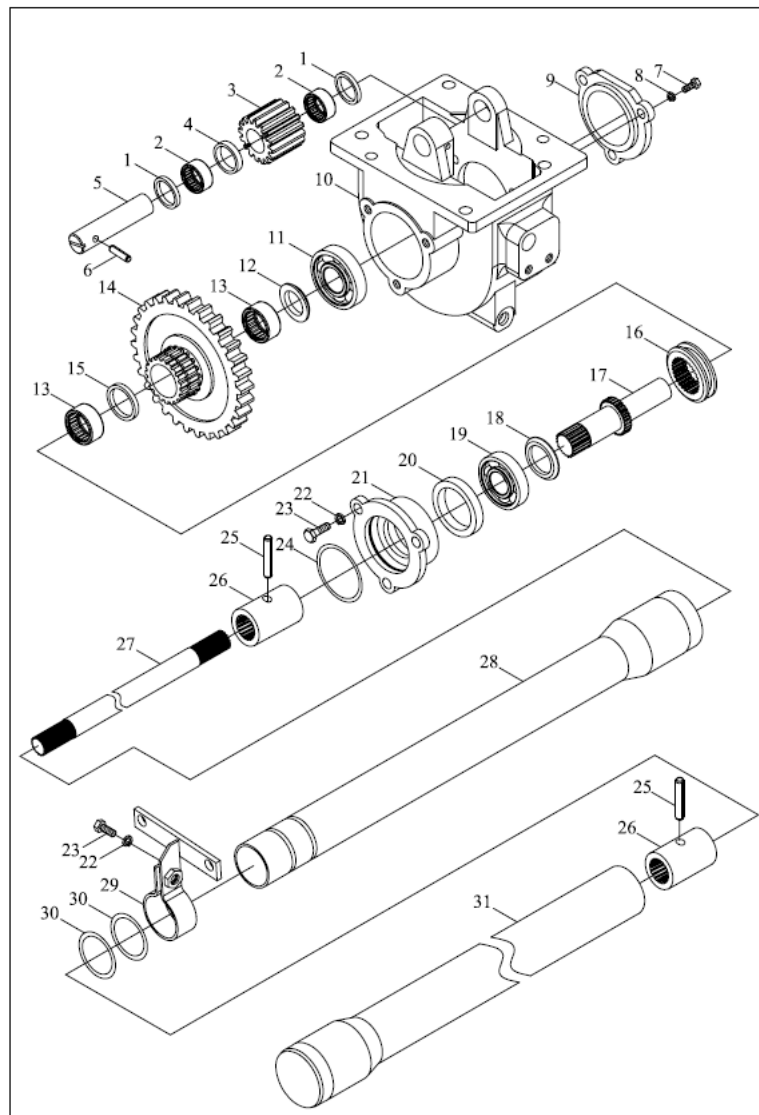

FT254.42.001-1 42.1-分动箱总成-1 TRANSFER CASE ASSEMBLY-1

标号 No.	代号 Code	名称 Description		数量 Quantity	备注 Remark
1	FT254.42.115	中间轴止推环	MIDDLE SHAFT THRUST RING	2	2011-11_
10	FT254.42.101	分动箱壳体	TRANSFER CASE HOUSING	1	2011-11_
11	GB/T276-6305	轴承	BEARING	1	2011-11_
12	FT254.42.107	输出轴后止推环	OUTPUT SHAFT REAR THRUST RING	1	2011-11_
12	FT254.42.107	输出轴后止推环	OUTPUT SHAFT REAR THRUST RING	1	2011-11_
14	FT254.42.104	分动箱从动齿轮	TRANSFER CASE DRIVEN GEAR	1	2011-11_
15	FT254.42.108	输出轴滚针轴承隔套	OUTPUT SHAFT ROLLING BEARING SPACER	1	2011-11_
16	FT254.42.103	啮合套	BUSH	1	2011-11_
17	FT254.42.102	输出轴	SHIFT COLLAR	1	2011-11_
18	FT254.42.109	输出轴前止推环	OUTPUT SHAFT OUTPUT SHAFT FRONT THRUST RING	1	2011-11_
19	GB/T276-6206	深沟球轴承		1	2011-11_
20	JBT2600-SG30X45X8	骨架油封	BEARING	1	2011-11_
21	FT254.42.111	前轴承盖	SHAFT SEAL	1	2011-11_
22	GB/T93-10-A0P	标准型弹簧垫圈	FRONT BEARING COVER	4	2011-11_
23	GB/T5783-M10X25-A3L	螺栓	WASHER BOLT	4	2011-11_
24	GB/T3452.1-53.0X2.65G	液压气动用O形橡胶密封圈		1	2011-11_
25	GB/T879.1-6X40	弹簧圆柱销	O-SEAL RING	2	2011-11_
26	FT254.42.113	花键套	SPRING COLUMN PIN	2	2011-11_
27	FT254.42.114	传动轴	SPLINE BUSH	1	2011-11_
28	FT254.42.011	后护套焊合件	TRANSMISSION SHAFT REAR SLEEVE WELDMENT	1	2011-11_
29	FT254.42.012	护套支架焊合件		1	2011-11_
3	FT254.42.118	分动箱中间齿轮	GUARD SLEEVE BRACKET WELDMENT	1	2011-11_
30	GB/T3452.1-36.5X2.65G	液压气动用O形橡胶密封圈	TRANSFER CASE MIDDLE GEAR	2	2011-11_
31	FT254.42.013	前护套焊合件	O-SEAL RING	1	2011-11_
4	FT254.42.117	中间轴滚针轴承隔套	FRONT SLEEVE WELDMENT	1	2011-11_

FT254.42.001 分动箱总成-1

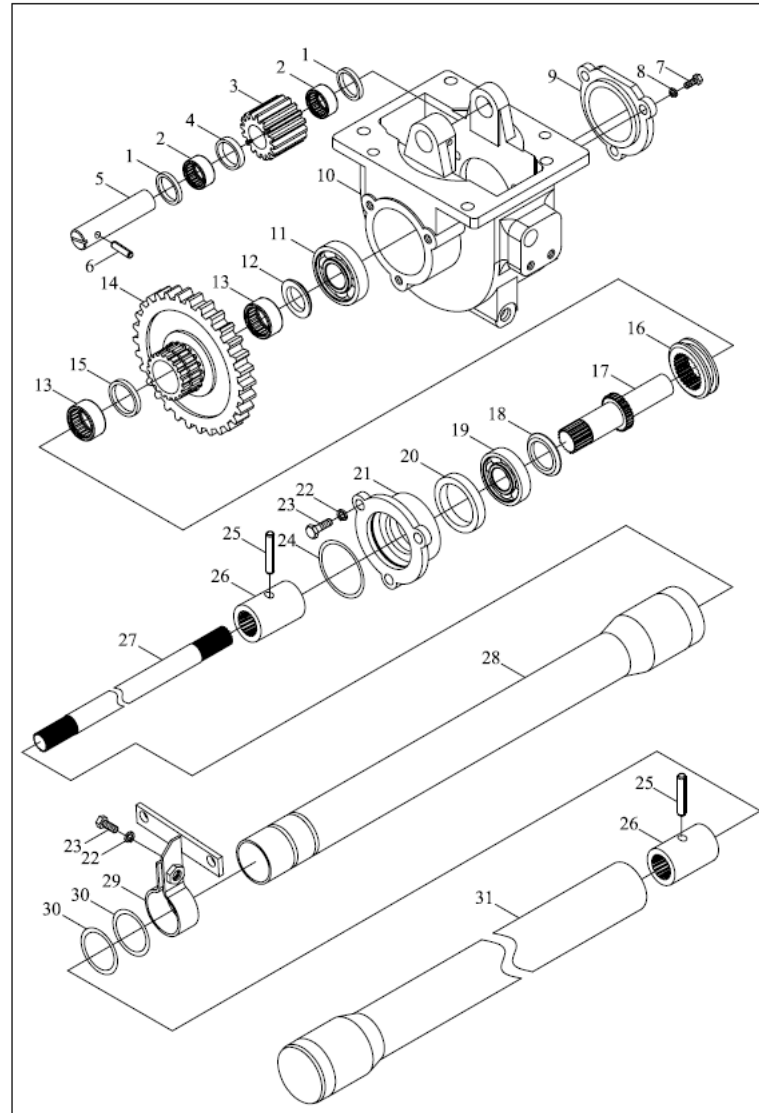

FT254.42.001-1 42.1-分动箱总成-1(续)

标号 No.	代号 Code	名称 Description		数量 Quantity	备注 Remark
5	FT254.42.116	中间轴	MIDDLE SHAFT	1	2011-11_
6	GBT879.1-6X35	弹性圆柱销	PIN	1	2011-11_
7	GBT5783-M8X20-A2L	螺栓	BOLT	3	2011-11_
8	GBT93-8-A0P	垫圈	WASHER	3	2011-11_
9	FT254.42.105	后轴承盖	REAR BEARING COVER	1	2011-11_
9	FT254.42.105	后轴承盖	REAR BEARING COVER	1	2011-11_

FT254.42.001 分动箱总成-2

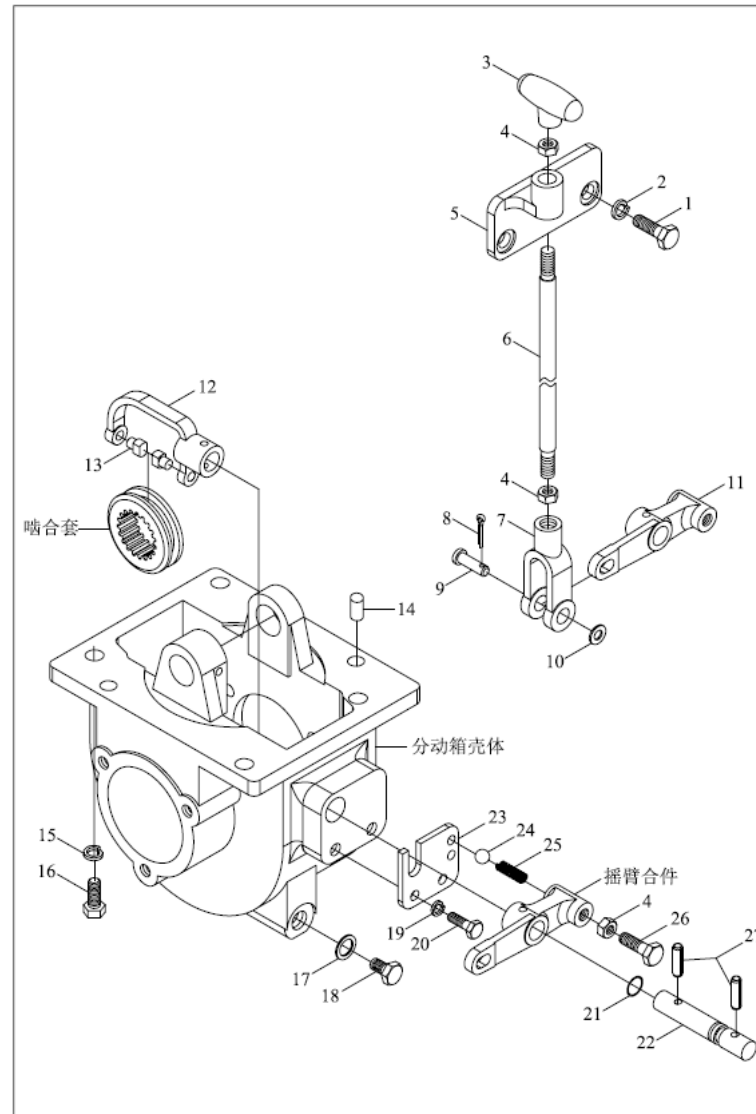

FT254.42.001-2 42.2-分动箱总成-2 TRANSFER CASE ASSEMBLY-2

标号 No.	代号 Code	名称 Description		数量 Quantity	备注 Remark
1	GBT5783-M12X25-A3L	六角头螺栓	BOLT	1	2011-11_
10	GBT97.1-8-A0P	平垫圈	WASHER	1	2011-11_
11	FT254.42.014	摇臂合件	ROCKER UNIT	1	2011-11_
12	FT254.42.123	分动箱拨叉	TRANSFER CASE FORK	1	2011-11_
13	FT254.42.121	分动箱拨叉头	TRANSFER CASE FORK HEAD	1	2011-11_
14	GBT119.1-10m6X18-A0P	圆柱销	PIN	2	2011-11_
15	GBT93-10-A0P	标准型弹簧垫圈	WASHER	4	2011-11_
16	GBT5783-M10X30-A3L	螺栓	BOLT	4	2011-11_
17	JBT982-12	组合密封垫圈	COMBINED SEAL GASKET	1	2011-11_
18	JBT3798-M12X1.5	螺塞	SCREW PLUG	1	2011-11_
19	GBT93-8-A0P	垫圈	WASHER	2	2011-11_
2	GBT93-12-A0P	弹簧垫圈	SPRING WASHER	1	2011-11_
20	GBT5783-M8X20-A2L	螺栓	BOLT	2	2011-11_
21	GBT3452.1-12.5X1.80G	液压气动用O形橡胶密封圈	O-SEAL RING	1	2011-11_
22	FT254.42.122	分动箱拨叉轴	TRANSFER CASE FORK SHAFT	1	2011-11_
23	FT254.42.119	定位板	LOCATING PLATE	1	2011-11_
24	GBT308-8	钢球8	STEEL BALL	1	2011-11_
25	FT304.42.124	定位弹簧	LOCATING SPRING	1	2011-11_
27	GBT879.1-6X24	弹性圆柱销	PIN	1	2011-11_
3	FT65.38.051	拉压手柄	PULL/PRESS HANDLE	1	2011-11_
4	GBT6170-M10-A3L	螺母	NUT	3	2011-11_
5	FT254.42.142	导向座	GUIDE SEAT	1	2011-11_
6	FT254.42.141	操纵杆	CONTROL ROD	1	2011-11_
7	FT804.42.150	拉杆前叉	PULL ROD FRONT FORK	1	2011-11_
8	GBT91-3.2X20-A0P	开口销	PIN	1	2011-11_

FT254.42.001 分动箱总成-2

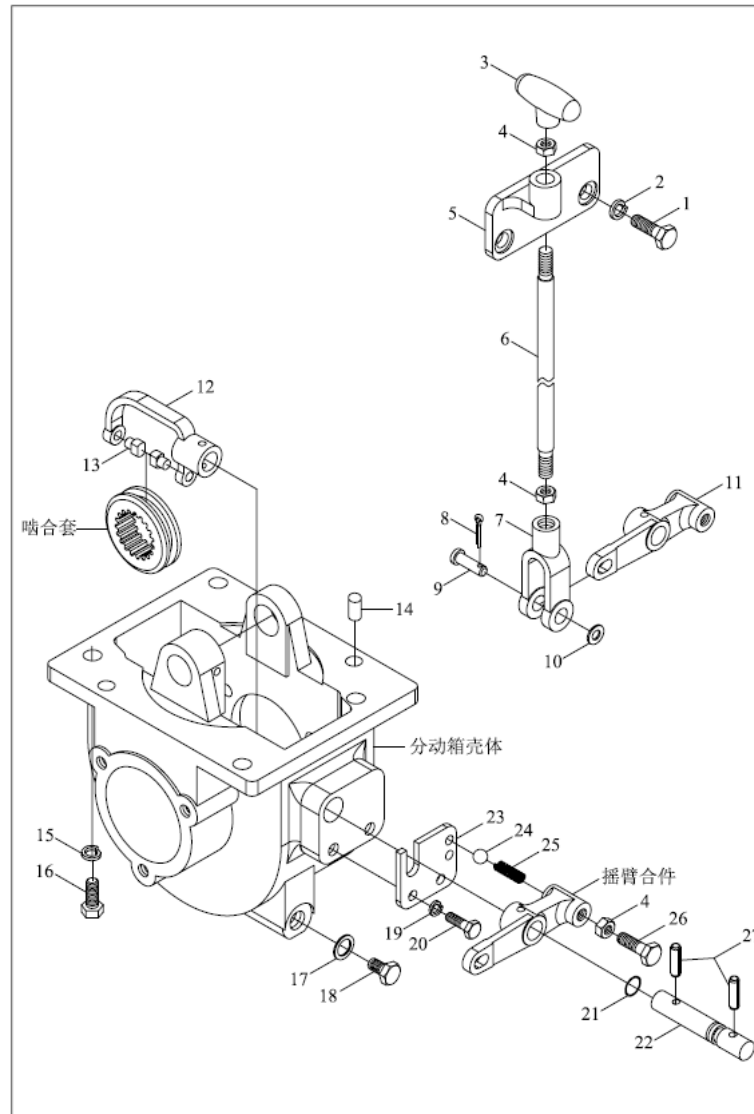

FT254.42.001-2 42.2-分动箱总成-2(续)

标号 No.	代号 Code	名称 Description		数量 Quantity	备注 Remark
8	GBT91-3.2X20-A0P	开口销	PIN	1	2011-11_
9	GBT882-B8X26	销轴	PIN	1	2011-11_

FT250.43.001 制动器及操纵机构-1

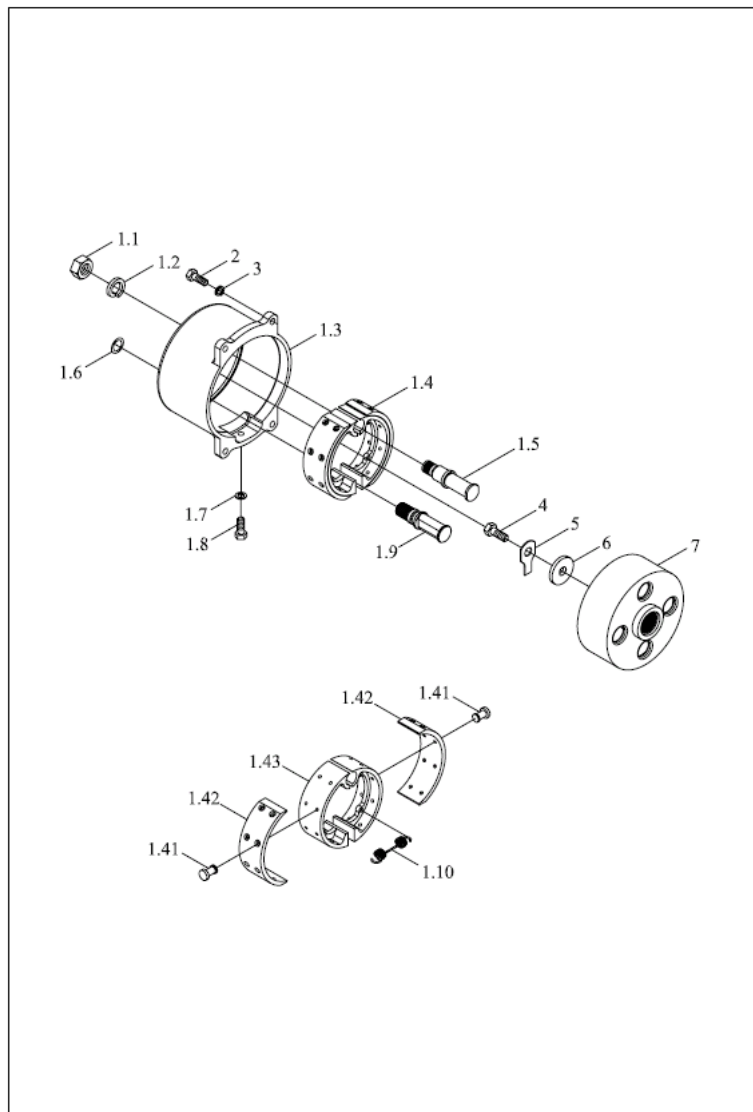

FT250.43.001-1 43-制动器及操纵机构-1

标号 No.	代号 Code	名称 Description		数量 Quantity	备注 Remark
1	FT250.43.011	制动器总成	BREAK ASS.	2	2011-11_
1.1	GBT6170-M16	螺母	NUT	1	2011-11_
1.2	GBT93-16-Zn.D	标准型弹簧垫圈	WASHER	1	2011-11_
1.3	FT250.43.121	制动器壳	BRAKE HOUSING	1	2011-11_
1.4	FT250.43.012	制动蹄总成	BRAKE HOOF ASSEMBLY	4	2011-11_
1.41	GBT109-4X13	平头铆钉	RIVET	16	2011-11_
1.42	FT250.43.129	制动摩擦片	BRAKE FRICTION PLATE	2	2011-11_
1.43	FT250.43.128	制动蹄	BRAKE SHOE	1	2011-11_
1.5	FT250.43.122	制动器销轴	BRAKE PIN SHAFT	1	2011-11_
1.6	GBT3452.1-15X2.65G	液压气动用O形橡胶密封圈	O-SEAL RING	1	2011-11_
1.7	GBT97.1-8-A0P	平垫圈	WASHER	1	2011-11_
1.8	GBT5783-M8X16-8.8-A3L	六角头螺栓	BOLT	1	
1.9	FT250.43.124	制动凸轮	BRAKE CAM	1	2011-11_
2	GBT5783-M8X25-8.8-A2L	六角头螺栓	BOLT	4	2004-01_
3	GBT93-8-Zn.D	标准型弹簧垫圈	WASHER	4	2004-01_
4	GBT5783-M12X25-8.8-A3L	六角头螺栓	BOLT	1	2004-01_
5	FT250.43.104a	单耳止动垫圈	STOPPING WASHER	1	2010-08_
5	FT250.43.104	单耳止动垫圈	STOPPING WASHER	1	2004-01_
6	FT250.43.101	垫圈	WASHER	1	2011-11_
7	FT250.43.105	制动鼓	BRAKE DRUM	1	2011-11_

FT250.43.001 制动器及操纵机构-2

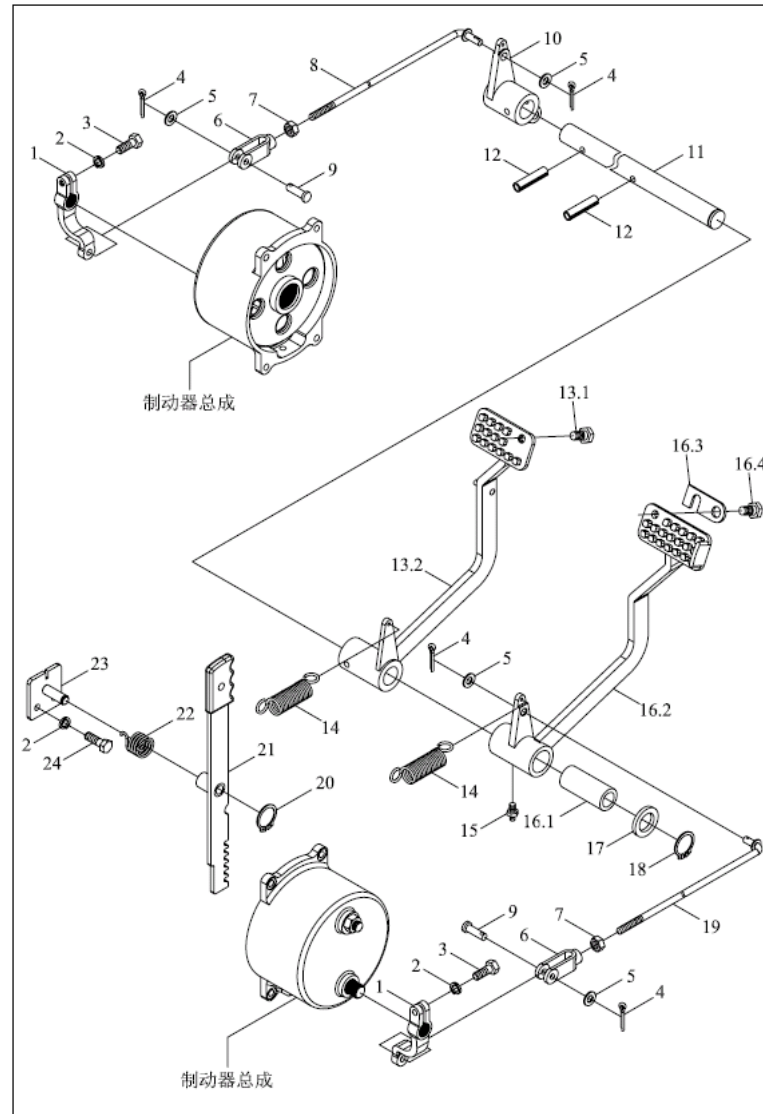

FT250.43.001-2 43-制动器及操纵机构-2

标号 No.	代号 Code	名称 Description		数量 Quantity	备注 Remark
1	FT250.43.102	制动摇臂	BRAKE ROCKER	2	2011-11_
10	FT250.43.111	左制动短摇臂	LEFT BRAKE SHORT ROCKER	1	2011-11_
11	FT250.43.113	制动器踏板轴	BRAKE PEDAL SHAFT	1	2011-11_
11	TE250.433-01	制动器踏板轴	BRAKE PEDAL SHAFT	1	2010-10_
12	GBT879.1-8X40	弹性圆柱销	PIN	2	2011-11_
13	TE250.433.1	左制动踏板总成	LEFT BRAKE PEDAL ASSEMBLY	1	2010-10_
13	FT250.43.018	左制动踏板总成	LEFT BRAKE PEDAL ASSEMBLY	1	2011-11_
13.1	FT65.43.132	螺钉	SCREW	1	2011-11_
13.2	FT250.43.021	左制动踏板焊合	LEFT BRAKE PEDAL WELDMENT	1	2011-11_
14	FT200.21.101	离合器踏板弹簧	CLUTCH PEDAL SPRING	2	2011-11_
15	JBT7940.1-M10X1	直通式压注油杯	STRAIGHT PRESSURE FILLING OIL CUP	1	2011-11_
16	TE250.433.2	右制动踏板总成	RIGHT BRAKE PEDAL ASSEMBLY	1	2010-10_
16	FT250.43.019	右制动踏板总成	RIGHT BRAKE PEDAL ASSEMBLY	1	2011-11_
16.1	FT250.43.162	制动踏板毂衬套	BRAKE PEDAL HUB BUSH	1	2011-11_
16.2	FT250.43.020	右制动踏板焊合	RIGHT BRAKE PEDAL WELDMENT	1	2011-11_
16.3	FT65.43.130	连锁板	INTERLOCKING PLATE	1	2011-11_
16.4	FT65.43.132	螺钉	SCREW	1	2011-11_
17	FT250.43.112	挡圈	RETAINER RING	1	2011-11_
18	GBT894.1-25	挡圈	RETAINER RING	1	2011-11_
19	FT250.43.013	右制动拉杆焊合	RIGHT BRAKE PULL ROD WELDMENT	1	2011-11_
2	GBT93-8-Zn.D	标准型弹簧垫圈	WASHER	4	2004-01_
20	GBT894.1-12	轴用弹性挡圈	SNAP RING	1	2011-11_
21	FT250.43.015	制动器锁定板组件	BRAKE LOCKING PLATE COMBINATION	1	2011-11_
22	FT250.43.157	扭力弹簧	TORQUE SPRING	1	2011-11_
23	FT250.43.025	固定板焊合	FIXING PLATE WELDMENT	1	2011-11_

FT250.43.001 制动器及操纵机构-2

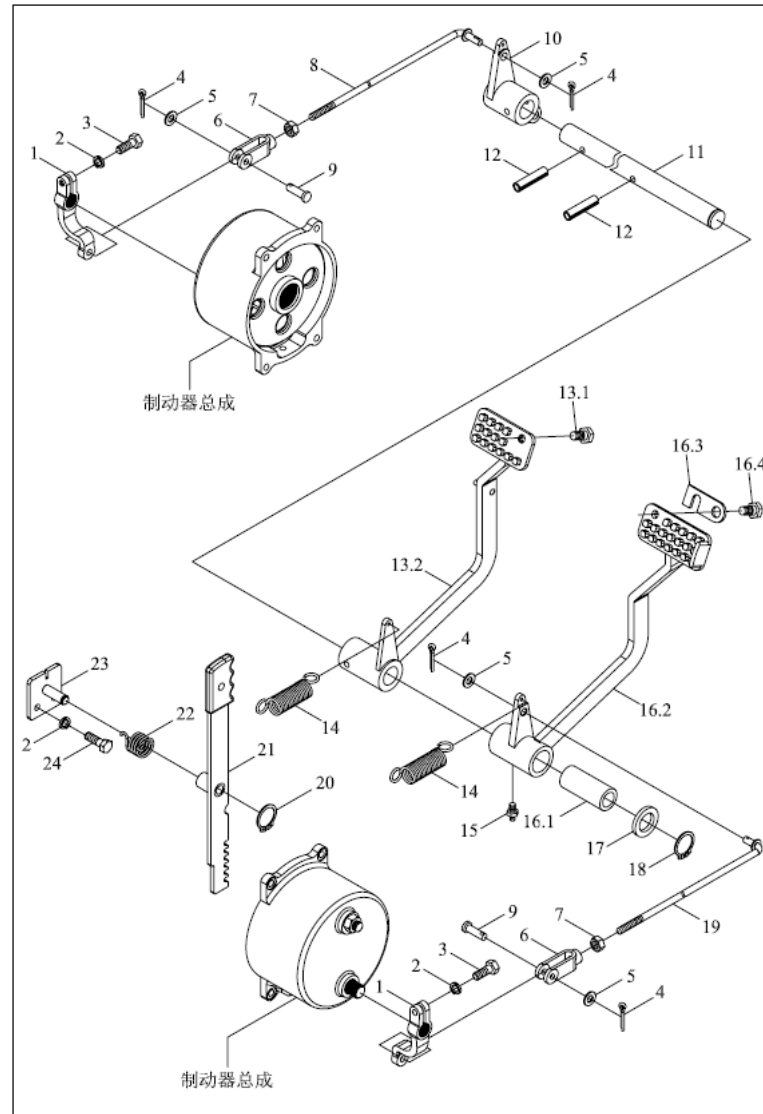

FT250.43.001-2 43-制动器及操纵机构-2(续)

标号 No.	代号 Code	名称 Description		数量 Quantity	备注 Remark
3	GBT5783-M8X25-8.8-A2	六角头螺栓	BOLT	2	2004-01_
4	GBT91-3.2X16-Zn.D	开口销	PIN	5	2011-11_
5	GBT97.1-8	垫圈	WASHER	5	2004-01_
6	FT250.43.103	制动拉杆调整叉	BRAKE PULL ROD ADJUSTING FORK	2	2011-11_
7	GBT6170-M8-Zn.D	1型六角螺母	NUT	2	2011-11_
8	FT250.43.014	左制动拉杆焊合	LEFT BRAKE PULL ROD WELDMENT	1	2011-11_
9	GBT882-B8 × 30-A0P	销轴	PIN	2	2011-04_
9	GBT882-B8 × 30-A0P	销轴	PIN	2	2011-04_

FT250.44B.001 座椅总成

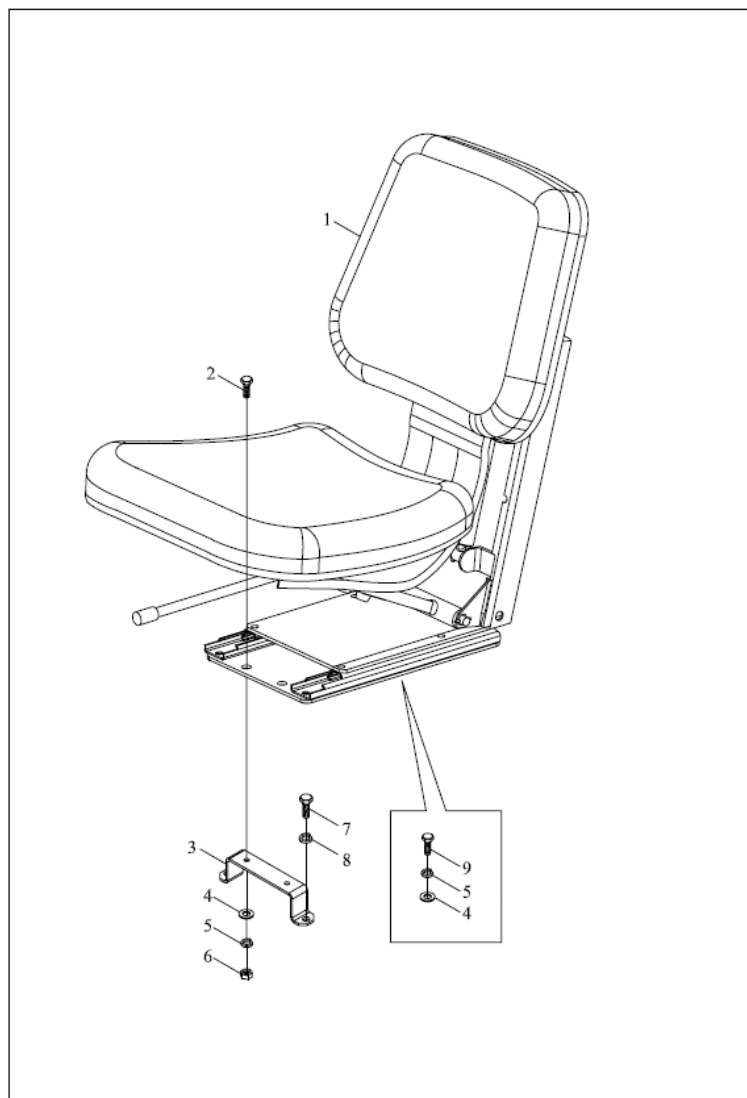

FT250.44B.001 44-座椅总成 44-SEAT ASSEMBLY

标号 No.	代号 Code	名称 Description		数量 Quantity	备注 Remark
1	FT250.44B.010	座椅	SEAT	1	2011-11_
2	GBT5783-M8X25-Zn.D	六角头螺栓	BOLT	2	2004-01_
3	FT250.44.144	座椅前支架	SEAT FRONT BRACKET	1	
4	GBT97.1-8	垫圈	WASHER	4	2011-11_
5	GBT93-8-Zn.D	标准型弹簧垫圈	WASHER	4	2004-01_
6	GBT6170-M8-Zn.D	1型六角螺母	NUT	2	2011-11_
7	GBT5783-M10X20-Zn.D	六角头螺栓	HEXAGON BOLT	2	2011-01_
8	GBT93-10-Zn.D	标准型弹簧垫圈	WASHER	2	2011-11_
9	GBT5783-M8X20-Zn.D	螺栓	BOLT	2	

FT250.46.001a 安全架总成

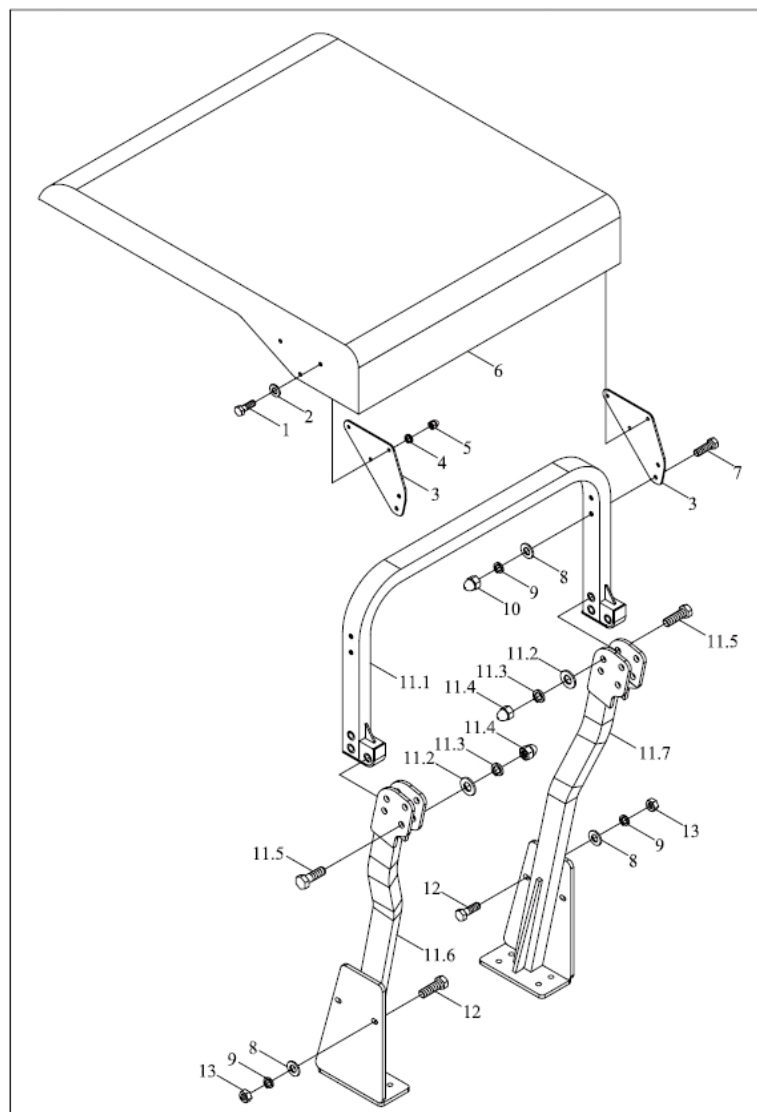

FT250.46.001a 46-安全架总成 46-SAFETY FRAME ASSEMBLY

标号 No.	代号 Code	名称 Description		数量 Quantity	备注 Remark
0	TB400.46C-01	堵盖	PLUG COVER	8	2010-10_
1	GBT5783-M10X30-A3L	螺栓	BOLT	6	2011-11_
10	GBT802-M12-A3L	组合式盖形螺母	NUT	4	2011-01_
11	FT250.46.010	支撑梁安装总成	SUPPORT BEAM INSTALLATION ASSEMBLY	1	2011-11_
11.1	FT250.46.011	上梁焊合	UPPER BEAM WELDMENT	1	2011-11_
11.2	GBT95-16-A0P	垫圈	WASHER	6	2011-11_
11.3	GBT93-16-A0P	弹簧垫圈	SPRING WASHER	6	2011-11_
11.5	GBT5782-M16X80-A3L	六角头螺栓	BOLT	6	2011-11_
11.6	FT250.46.013	左支撑梁焊合	LEFT SUPPORTING BEAM WELDMENT	1	2011-11_
11.7	FT250.46.014	右支撑梁焊合	RIGHT SUPPORTING BEAM WELDMENT	1	2011-11_
12	GBT5783-M12X35-A3L	螺栓	BOLT	4	2011-11_
12	GBT5783-M12X35-A3L	螺栓	BOLT	4	2011-11_
2	FT400.46.021	垫圈合件	WASHER UNIT	6	2011-11_
3	FT250.46.106	遮阳棚固定板	SHADOW LOCKING PLATE	2	2011-11_
4	GBT93-10-A0P	标准型弹簧垫圈	WASHER	6	2011-11_
5	GBT802-M10-A3L	组合式盖形螺母	NUT	6	2004-01_
6	FT300.46.012	遮阳棚总成	SHADOW ASSEMBLY	1	2011-11_
7	GBT5782-M12X65-10.9-A2L	六角头螺栓	BOLT	4	2004-01_
7	GBT5782-M12X65-10.9-A2L	六角头螺栓	BOLT	4	2004-01_
8	GBT95-12-A0P	垫圈12-A0P	WASHER	8	2011-11_
9	GBT93-12-A0P	弹簧垫圈	SPRING WASHER	8	2011-11_

FT250.48D.001 电器系统总成-1

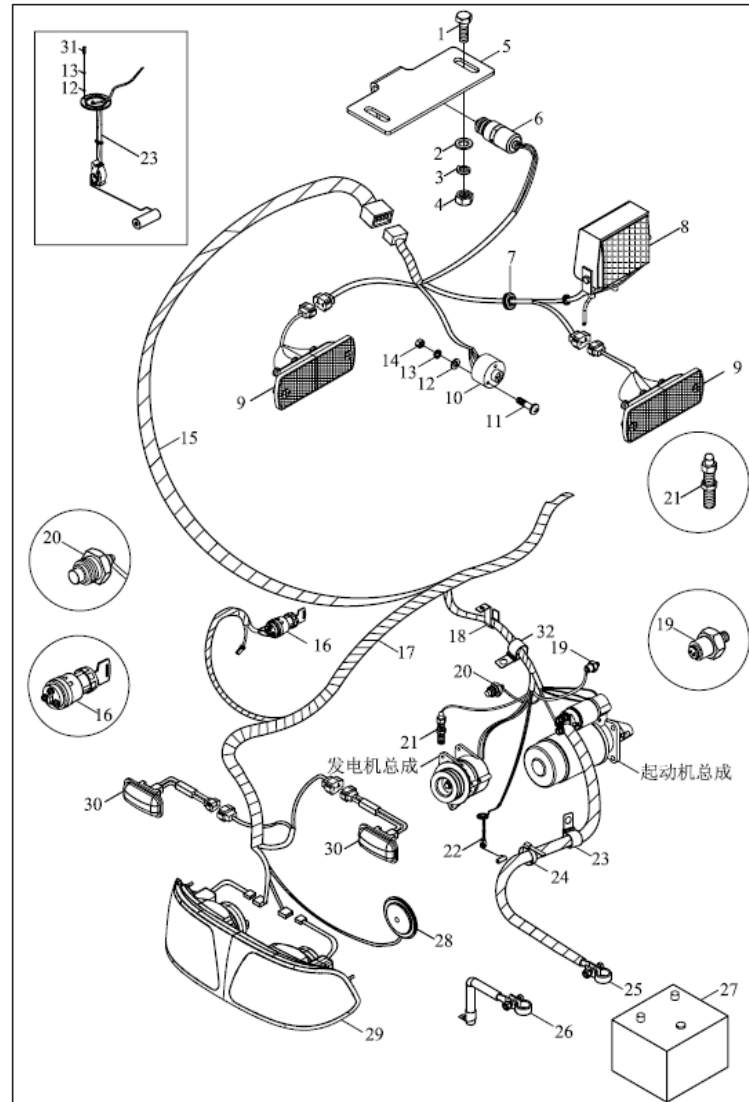

FT250.48D.001-1 48.1-电气系统总成-1 ELECTRICAL SYSTEM ASSEMBLY-1

标号 No.	代号 Code	名称 Description	数量 Quantity	备注 Remark
10	FT65.48.080	后挂车插座	1	2011-11_
11	GBT818-M5X35-Zn.D	十字槽盘头螺钉	3	2011-11_
11	GBT818-M5X35-Zn.D	十字槽盘头螺钉	3	2011-11_
12	GBT97.1-5	平垫圈	14	2011-11_
15	FT250.48.018	右后灯线束总成	1	2011-11_
16	FT300.48.064	点火锁	1	2011-11_
17	FT250.48.016	主线束总成	1	2011-11_
18	FT304.48L.203	线束紧固夹	6	2011-11_
19	FT250.48.036	机油压力传感器	1	2011-11_
2	GBT97.1-8	垫圈	2	2011-11_
20	FT300.48.072	水温传感器	1	2011-11_
21	FT300.48.074	转速传感器	1	2011-11_
22	FT250.48.037	油量传感器	1	2011-11_
23	FT250.48.101	线束紧固夹	1	2011-11_
24	3724D01-201	可松式扎带	6	2011-11_
25	FT250.48.027	蓄电池正极电缆总成	1	2011-11_
26	FT250.48.028	蓄电池负极电缆总成	1	2011-11_
27	FT250.48.029	蓄电池总成	1	2011-11_
28	FT65.48.340	电喇叭	1	2011-11_
29	FT250.48.045	前灯组合总成	1	2011-11_
30	FT250.48.023	转向灯总成	2	2011-11_
31	GBT68-M5X10-Zn.D	开槽沉头螺钉	5	2011-11_
32	FT300.48.105	线束紧固夹(3)	2	2011-11_
4	GBT6170-M8-Zn.D	1型六角螺母	2	2011-11_
5	FT250.48.134	刹车开关固定架	1	2011-11_

FT250.48D.001 电器系统总成-1

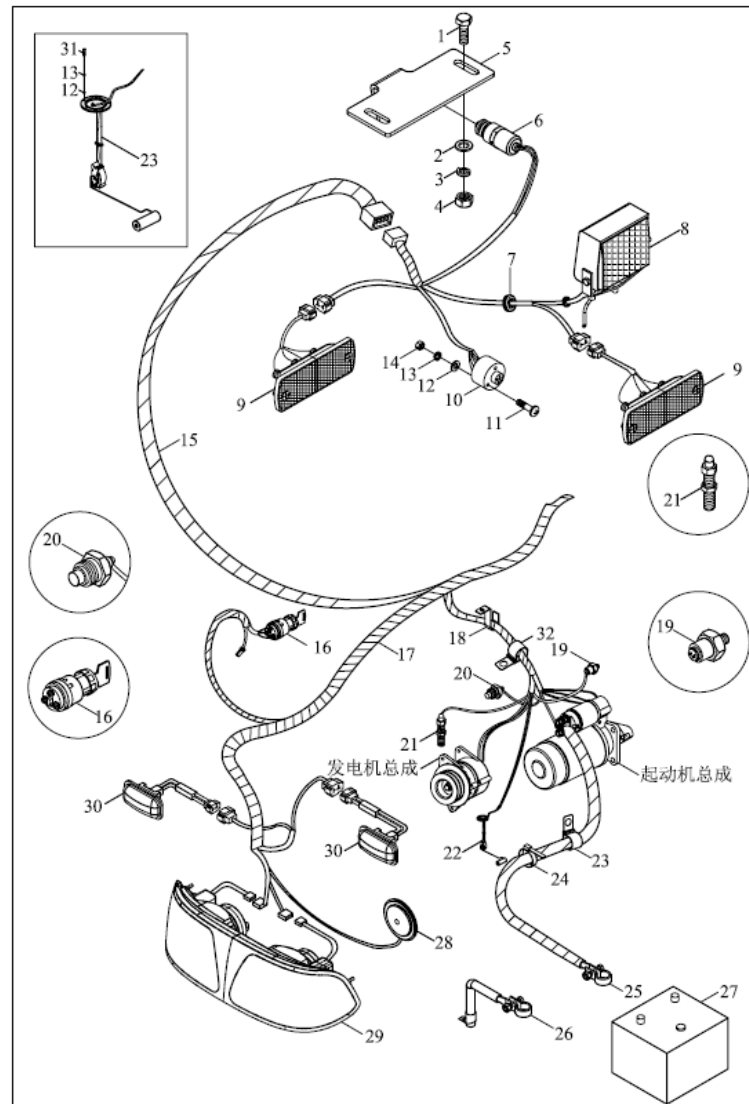

FT250.48D.001-1 48.1-电气系统总成-1(续)

标号 No.	代号 Code	名称 Description		数量 Quantity	备注 Remark
6	FT300.48.033	制动灯开关	BRAKE LIGHT SWITCH	1	2011-11_
7	FT65.48.101	穿线胶圈(四)	THROUGH HARNESS WASHER (4)	1	2011-11_
8	FT250.48.025	后工作灯总成	REAR WORKING LIGHT ASSEMBLY	1	2011-11_
9	FT250.48.024	后尾灯总成	TAIL LAMP ASSEMBLY	1	2011-11_
9	FT250.48.024	后尾灯总成	TAIL LAMP ASSEMBLY	1	2011-11_

FT250.48D.001 电器系统总成-2

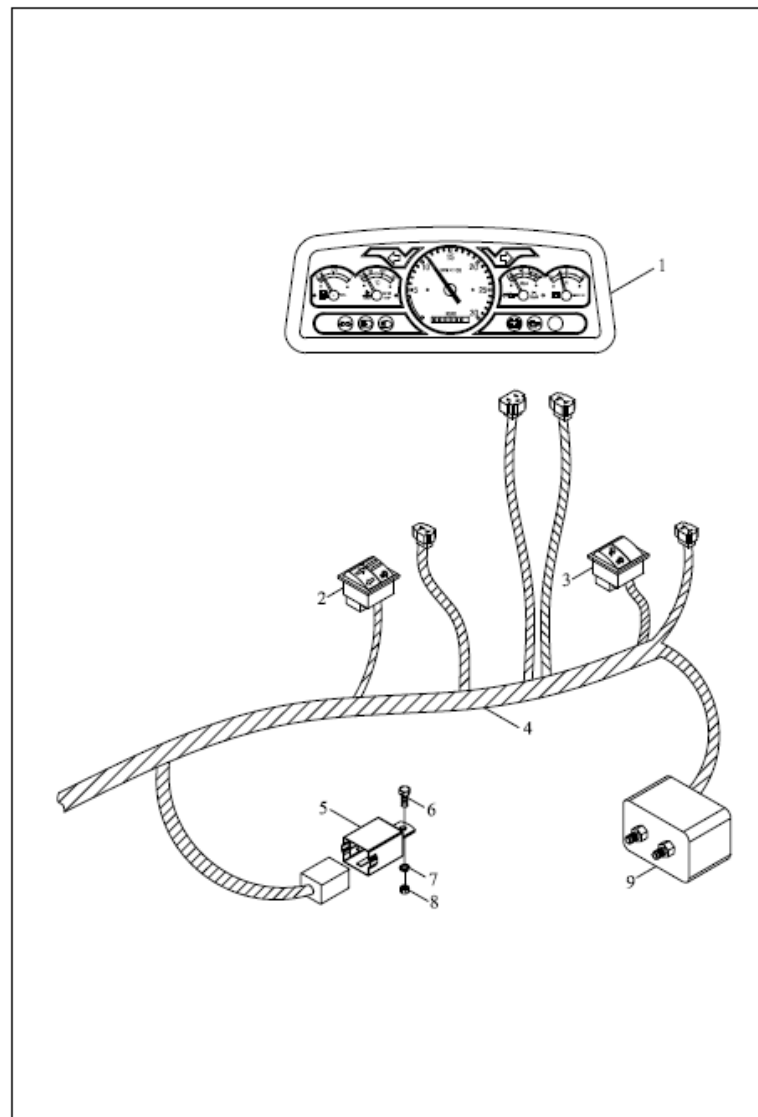

FT250.48D.001-2 48.2-电器系统总成-2 ELECTRICAL SYSTEM ASSEMBLY-2

标号 No.	代号 Code	名称 Description		数量 Quantity	备注 Remark
1	FT250.48D.030	组合仪表总成	COMBINED INSTRUMENT ASSEMBLY	1	2011-11_
1.1	FT250.48D.031	组合仪表总成	COMBINED INSTRUMENT ASSEMBLY	1	2011-11_
2	FT250.48.038	左翘板开关	LEFT PADDLE SWITCH	1	2011-11_
3	FT250.48.039	右翘板开关	RIGHT BUTTON SWITCH	1	2011-11_
4	FT250.48D.017	仪表线束总成	INSTRUMENT HARNESS ASSEMBLY	1	2011-11_
5	FT250.48.043	电子闪光器	ELECTRIC FLASH	1	2011-11_
9	FT250.48.042	保险丝盒总成	FUSE BOX ASSEMBLY	1	2011-11_

FT250.49A.001 工具箱安装总成

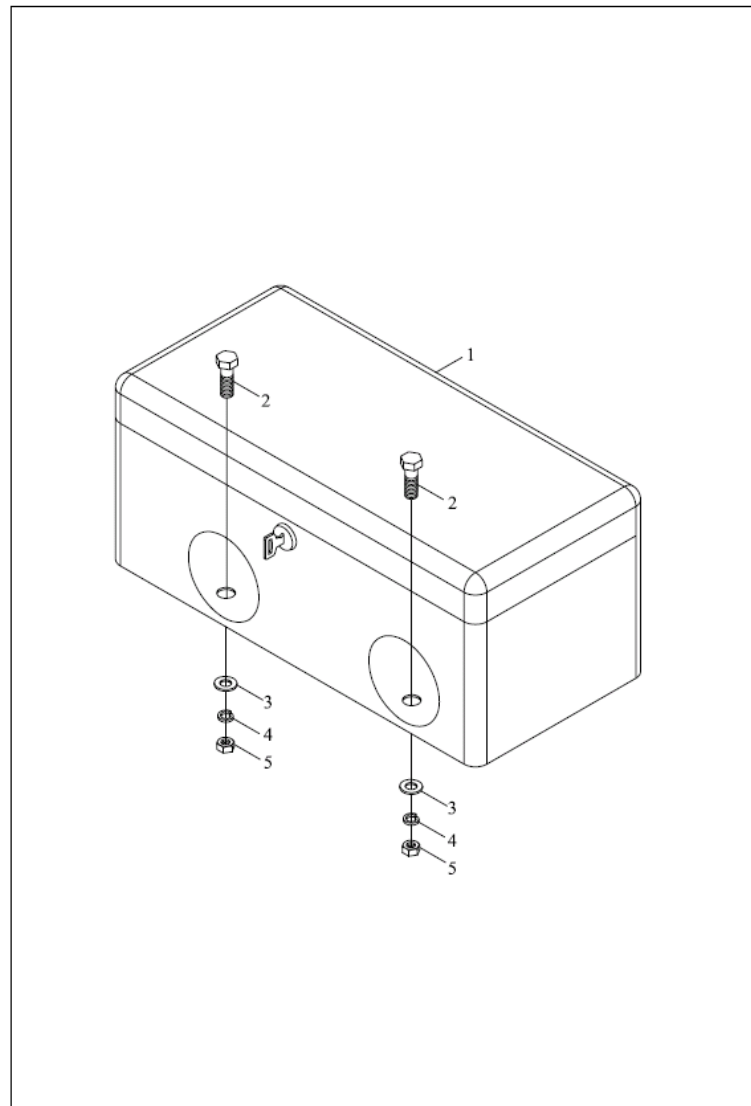

FT250.49A.001 49-工具箱安装总成 49-TOOL BOX INSTALLATION ASSEMBLY

标号 No.	代号 Code	名称 Description		数量 Quantity	备注 Remark
1	FT250.49.010	工具箱总成	TOOL BOX ASSEMBLY	1	2011-11_
2	GBT5781-M8X16-A2L	六角头螺栓	BOLT	2	2011-11_
3	GBT97.1-8-A0P	平垫圈	WASHER	2	2011-11_
5	GBT6170-M8-A2L	螺母	NUT	2	2011-11_

FT250.50.001 燃油箱总成

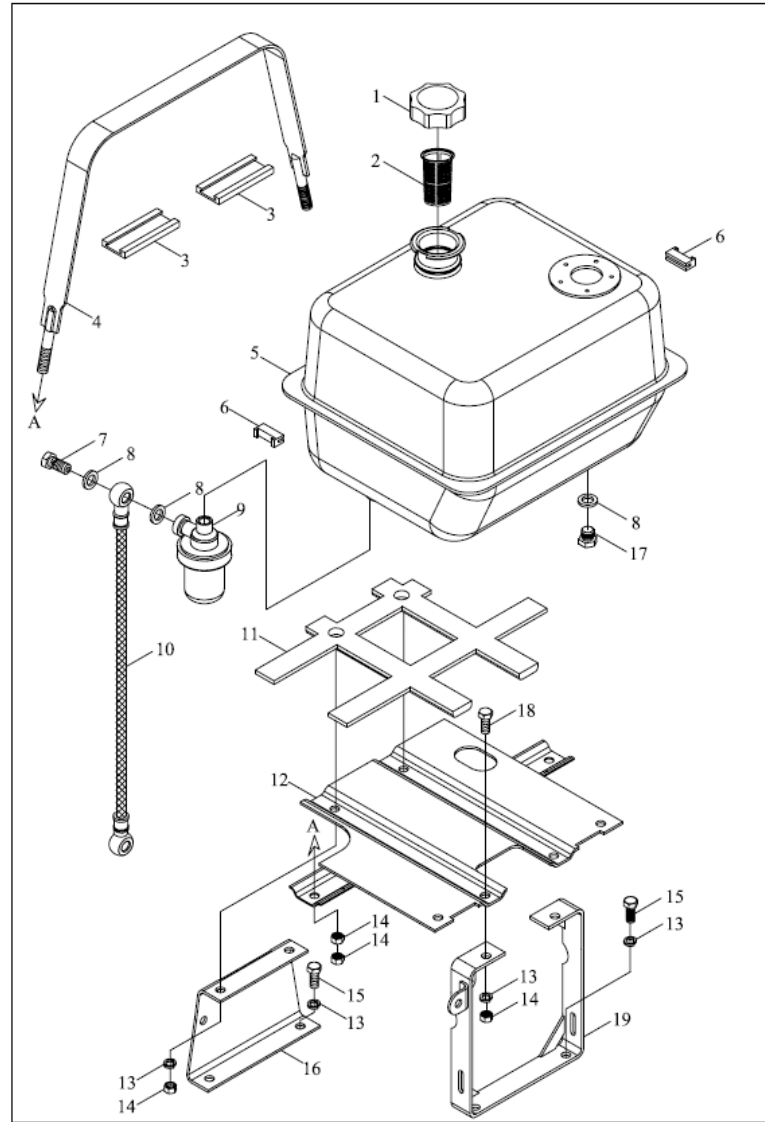

FT250.50.001 50-燃油箱总成

标号 No.	代号 Code	名称 Description		数量 Quantity	备注 Remark
0	FT250.50.017	油箱后支架焊合件 (二)	OIL TANK REAR BRACKET WELDMENT (2)	1	2011-11_
1	TA650.502.3	油箱盖总成	OIL TANK COVER ASSEMBLY	1	2011-11_
10	FT250.50.023	输油管总成	OIL CONVEYING PIPE ASSEMBLY	1	2011-11_
11	FT250.50.103	油箱胶垫	OIL TANK RUBBER WASHER	1	2011-11_
12	FT250.50.011	油箱支撑板焊合件	OIL TANK SUPPORT PLATE WELDMENT	1	2011-11_
13	GBT93-10-A0P	标准型弹簧垫圈	WASHER	8	2011-11_
14	GBT6170-M10-A3L	螺母	NUT	8	2011-11_
15	GBT5783-M10X20-A3L	螺栓	BOLT	6	2011-11_
16	FT250.50.106	油箱前支架	OIL TANK FRONT BRACKET	1	2011-11_
17	FT250.50.107	放油塞	OIL DISCHARGING PLUG	1	2011-11_
18	GBT5783-M10X35-A3L	螺栓	BOLT	2	2011-11_
19	FT250.50.016	油箱后支架焊合件	OIL TANK REAR BRACKET WELDMENT	1	2011-11_
2	FT250.50.015a	滤网总成	FILTER MESH ASSEMBLY	1	2011-11_
3	FT250.50.102	钢带胶垫	STEEL BAND RUBBER WASHER	2	2011-11_
4	FT250.50.013	钢带焊合件	STEEL BAND WELDMENT	1	2011-11_
5	FT250.50.012b	油箱体焊合件	OIL TANK BODY WELDMENT	1	2011-11_
6	FT250.50.104	钢带胶卡	STEEL BAND RUBBER CLAMP	2	2011-11_
7	FT65.50.106	空心螺栓	HOLLOW BOLT	1	2011-11_
8	JBT982-14	组合密封垫圈	COMBINED SEAL GASKET	3	2011-11_
8	JBT982-14	组合密封垫圈	COMBINED SEAL GASKET	3	2011-11_
9	FT65.50.033	沉淀杯总成	SEDIMENT CUP ASSEMBLY	1	2011-11_
9	FT65.50.033	沉淀杯总成	SEDIMENT CUP ASSEMBLY	1	2011-11_

FT250.55.001 提升器总成-1

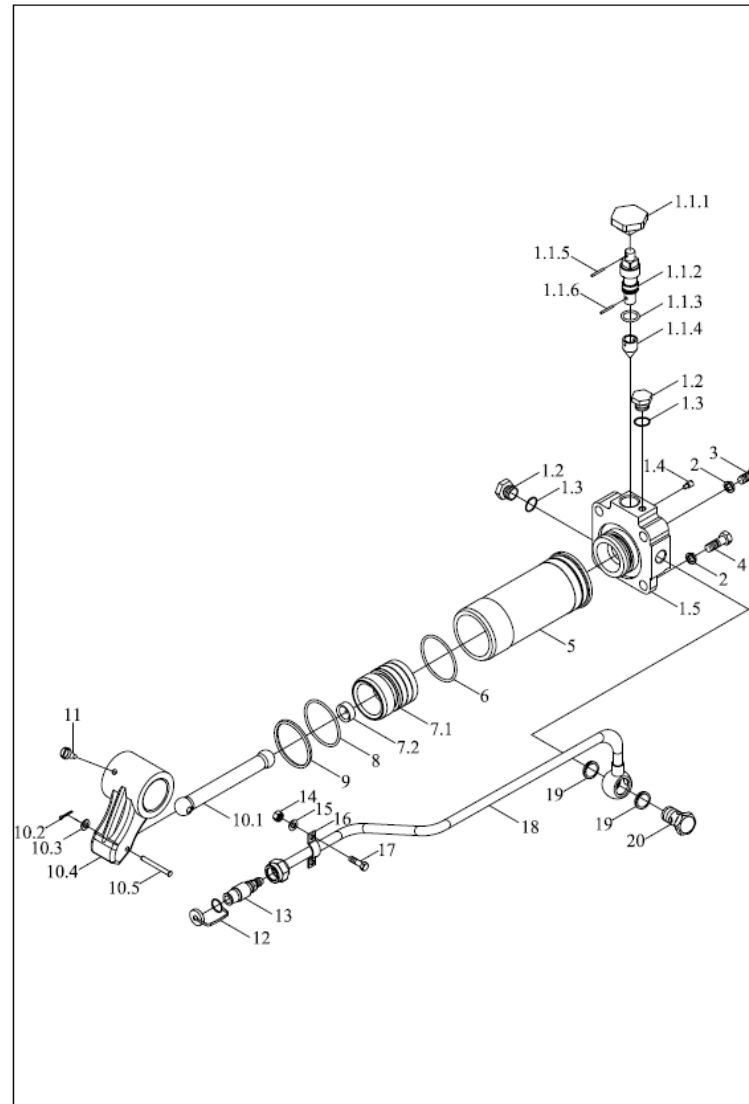

FT250.55.001-1 55.1-提升器总成-1 LIFTER ASSEMBLY-1

标号 No.	代号 Code	名称 Description		数量 Quantity	备注 Remark
1	FT250.55.010	缸头总成	CYLINDER HEAD ASSEMBLY	1	2011-11_
1.1	FT250.55.019	调节阀总成	ADJUSTING VALVE ASSEMBLY	1	2011-11_
1.11	FT65.55.140	手轮	HANDLE WHEEL	1	2011-11_
1.12	FT250.55.128	调节阀杆	ADJUSTING VALVE ROD	1	2011-11_
1.13	GBT3452.1-17X2.65G	液压气动用O形橡胶密封圈	O-SEAL RING	1	2011-11_
1.14	FT250.55.129	调节阀	ADJUSTING VALVE	1	2011-11_
1.15	GBT879-4X20	销	PIN	1	2011-11_
1.16	GBT879-3X20	销	PIN	1	2011-11_
1.2	JBZQ4450-M10X1	螺塞	SCREW PLUG	2	2011-11_
1.3	JBZQ4454-10X13.5	密封圈	SEAL RING	2	2011-11_
1.4	GBT829-M5X6X4	螺钉	SCREW	1	2011-11_
1.5	FT250.55.126	缸头	CYLINDER HEAD	1	2011-11_
10	FT250.55.012	内提升臂总成	INNER LIFT ARM ASSEMBLY	1	2011-11_
10.1	220.55.132	顶杆	TOP ROD	1	2011-11_
10.3	GBT95-6	垫圈	WASHER	1	2011-11_
10.4	220.55.133	内提升臂	INNER LIFTING ARM	1	2011-11_
10.5	GBT882-B6X50	销轴	PIN	1	2011-11_
12	FT354.58A.103	防尘盖	DUSTPROOF COVER	1	2011-11_
13	FT354.58A.030	快换接头	QUICK CHANGING JOINT	1	2011-11_
14	GBT6170-M8	螺母M8	NUT M8	2	2011-11_
15	GBT97.1-8	垫圈	WASHER	2	2011-11_
16	FT250.55.120	管夹	PIPE CLAMP	1	2011-11_
17	GBT5781-M8X20	六角头螺栓全螺纹C级		2	2011-11_
18	FT250.55.016	液压输出管焊合	HYDRAULIC OUTPUT PIPE WELDMENT	1	2011-11_
19	JBZQ4454-18X22	密封垫	SEAL GASKET	2	2011-11_

FT250.55.001 提升器总成-1

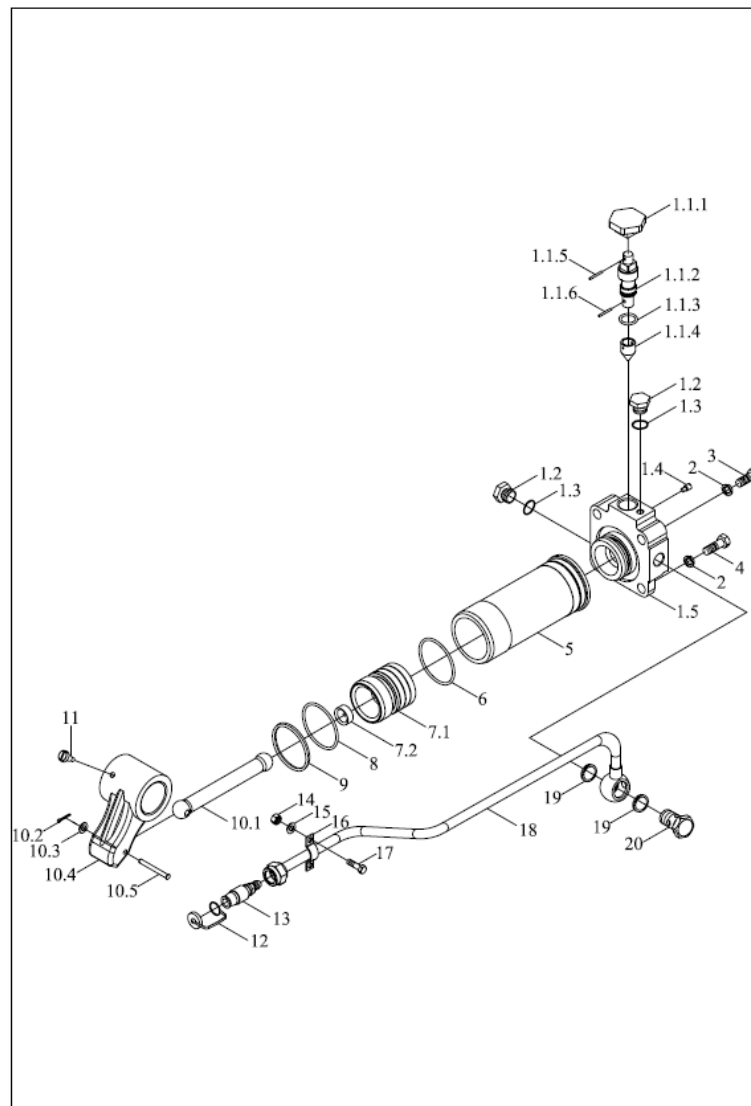

FT250.55.001-1 55.1-提升器总成-1(续)

标号 No.	代号 Code	名称 Description		数量 Quantity	备注 Remark
2	GBT93-14	垫圈	WASHER	4	2011-11_
2	GBT93-14	垫圈	WASHER	4	2011-11_
20	FT250.55.119	空心螺栓	HOLLOW BOLT	1	2011-11_
5	FT250.55.102	油缸筒	OIL CYLINDER CANISTER	1	2011-11_
6	GBT3452.1-71X2.65	液压气动用O形橡胶密封圈	O-SEAL RING	1	2011-11_
6	GBT3452.1-71X2.65	液压气动用O形橡胶密封圈	O-SEAL RING	1	2011-11_
7	FT250.55.011	活塞总成	PISTON	1	2011-11_
7.1	FT250.55.130	活塞	PISTON	1	2011-11_
7.2	FT250.55.131	通气塞体焊接加油口螺堵	SCREW PLUG	1	2011-11_
8	GBT3452.1-53X5.3G	液压气动用O形橡胶密封圈	O-SEAL RING	2	2011-11_
9	FT250.55.104	垫圈	WASHER	1	2011-11_

FT250.55.001 提升器总成-2

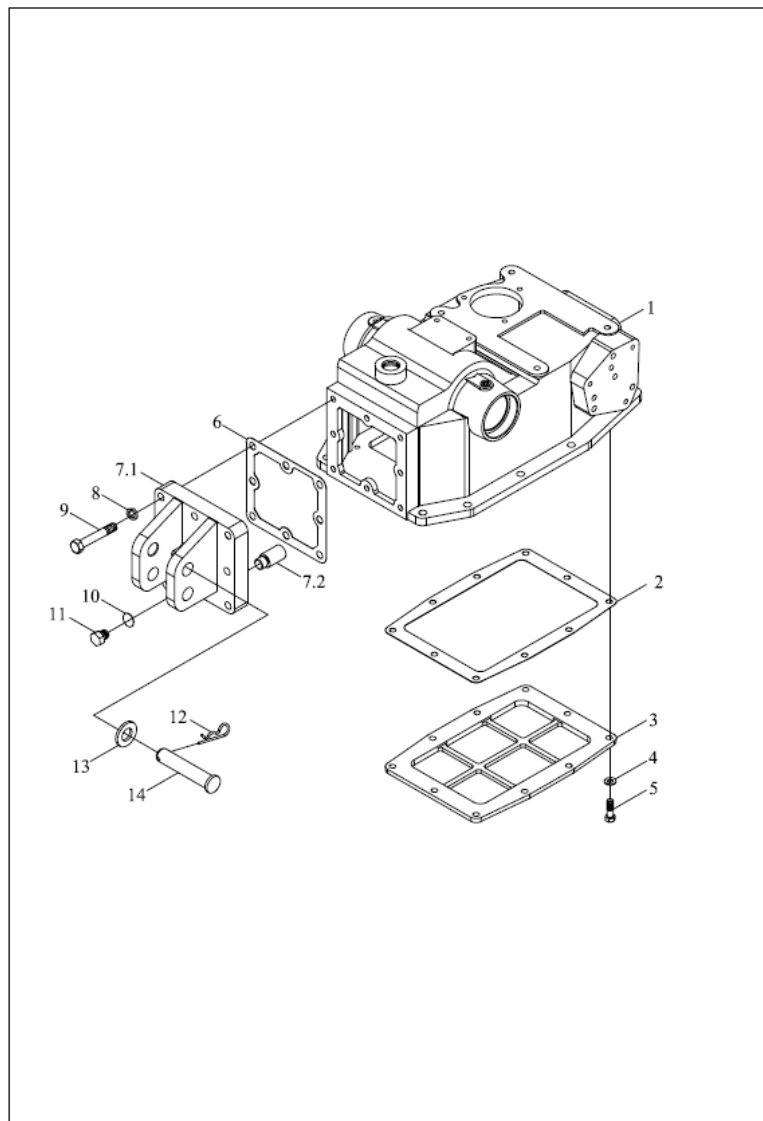

FT250.55.001-2 55.2-提升器总成-2 LIFTER ASSEMBLY-2

标号 No.	代号 Code	名称 Description		数量 Quantity	备注 Remark
1	FT250.55.101	提升器壳体	LIFTER HOUSING	1	2011-11_
10	JBZQ4454-10X13.5	密封圈	SEAL RING	1	2011-11_
11	FT250.55.108	放油塞	OIL DISCHARGING PLUG	1	2011-11_
12	220.31.105	弹簧锁销	SPRING LOCK PIN	1	2011-11_
13	GBT97.1-20	垫圈	WASHER	1	2011-11_
14	FT250.55.107	上拉杆前连接销	UPPER PULL ROD FRONT CONNECTING PIN	1	2011-11_
2	FT250.55.116	底板纸垫	BOTTOM PLATE PAPER GASKET	1	2011-11_
3	FT250.55.115	提升器壳体底板	LIFTER HOUSING BOTTOM PLATE	1	2011-11_
4	GBT97.1-8	垫圈	WASHER	10	2011-11_
5	GBT5783-M8X20	螺栓	BOLT	10	2011-11_
5	GBT5783-M8X20	螺栓	BOLT	10	2011-11_
6	FT250.55.117	后端盖纸垫	REAR END COVER PAPER GASKET	1	2011-11_
7	FT250.55.015	后端盖总成	REAR END COVER ASSEMBLY	1	2011-11_
7.1	FT250.55.140	后端盖	REAR END COVER	1	2011-11_
7.2	FT250.55.141	限位销	LIMITING PIN	1	2011-11_
8	GBT93-10	垫圈10	WASHER 10	8	2011-11_

FT250.55.001 提升器总成-3

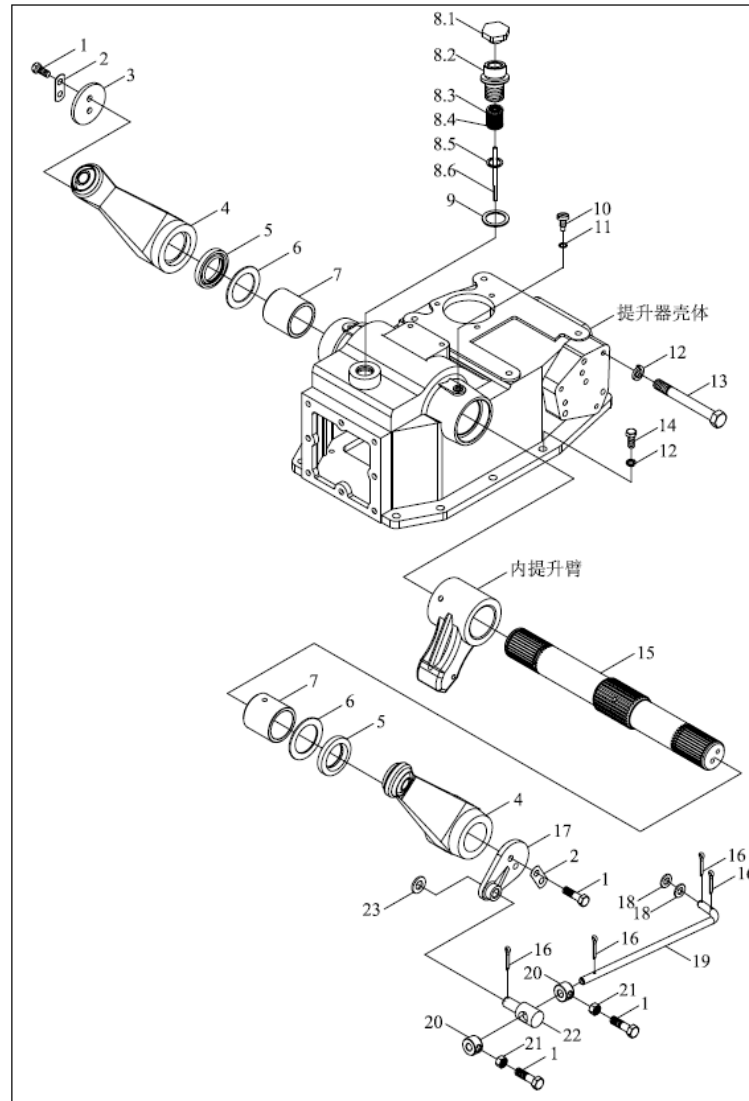

FT250.55.001-3 55.3-提升器总成-3 LIFTER ASSEMBLY-3

标号 No.	代号 Code	名称 Description		数量 Quantity	备注 Remark
1	GBT5783-M8X20	螺栓	BOLT	6	2011-11_
1	GBT5783-M8X20	螺栓	BOLT	6	2011-11_
11	JBZQ4454-8X11.5	密封垫	SEAL GASKET	2	2011-11_
12	GBT93-10	垫圈10	WASHER 10	13	2011-11_
14	GBT5783-M10X30	六角头螺栓	BOLT	10	2011-11_
15	FT250.55.103	提升轴	LIFTING SHAFT	1	2011-11_
17	FT250.55.136	回位挡板	RETURN RETAINER PLATE	1	2011-11_
18	GBT97.1-8	垫圈	WASHER	2	2011-11_
19	FT250.55.113	回位推杆	RETURN PUSH ROD	1	2011-11_
2	FT250.55.111	止动垫片	THRUST WASHER	2	2011-11_
20	FT250.55.110	挡块	RETAINER BLOCK	2	2011-11_
20	FT250.55.110	挡块	RETAINER BLOCK	2	2011-11_
21	GBT6170-M8	螺母M8	NUT M8	2	2011-11_
22	FT250.55.105	挡销	RETAINER PIN	1	2011-11_
23	GBT97.1-12	垫圈	WASHER	1	2011-11_
3	FT250.55.109	提升轴压板	LIFTING SHAFT PRESSURE PLATE	1	2011-11_
4	FT250.55.013	提升臂总成	LIFTING ARM ASSEMBLY	2	2011-11_
5	JBT2600-PD42X62X10	骨架油封	SHAFT SEAL	2	2011-11_
6	FT250.55.114	密封挡片	SEAL RETAINER PIECE	2	2011-11_
7	FT250.55.106	轴套	SHAFT SLEEVE	2	2011-11_
8	FT250.55.014	加油通气螺塞总成	REFUELING AND AIRING PLUG ASSEMBLY	1	2011-11_
8.1	FT300.38.102	通气塞盖	AIR PLUG COVER	1	2011-11_
8.2	FT300.38.172a	加油螺塞	OIL REFILLING PLUG	1	2011-11_
8.3	FT300.38.103	呼吸器滤芯	BREATH FILTER ELEMENT	1	2011-11_
8.4	FT650.40.167	座板	SEAT PLATE	1	2011-11_

FT250.55.001 提升器总成-3

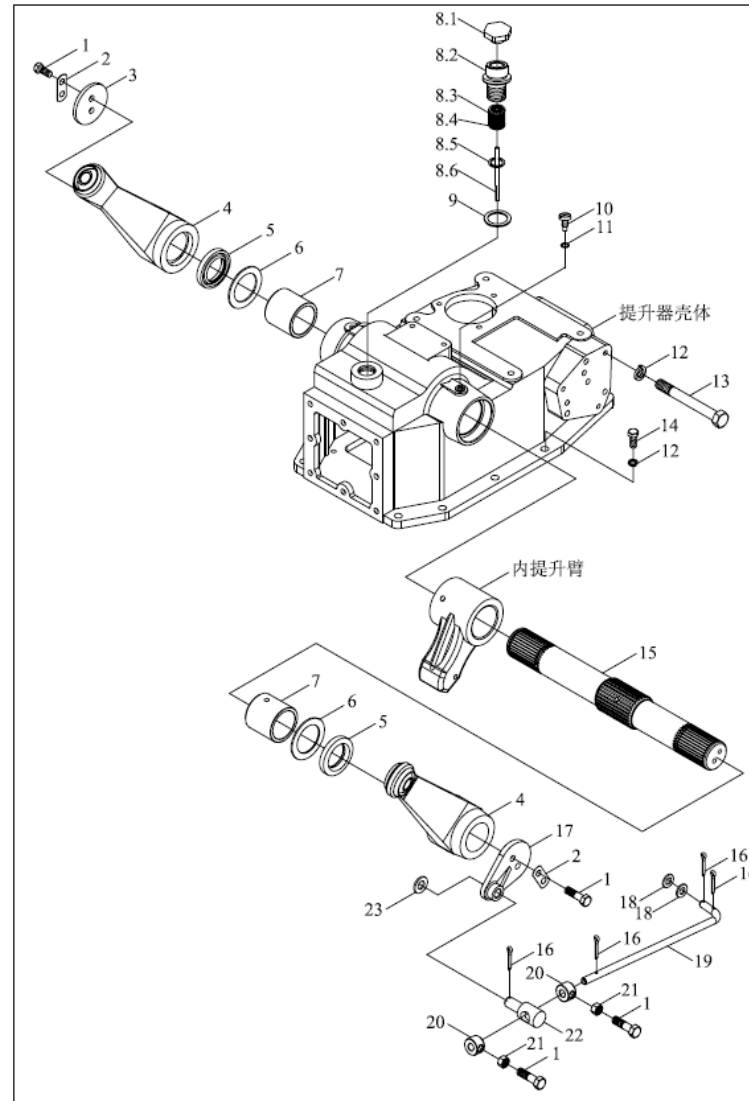

FT250.55.001-3 55.3-提升器总成-3(续)

标号 No.	代号 Code	名称 Description		数量 Quantity	备注 Remark
8.5	GBT893.1-26	孔用弹性挡圈	SNAP RING	1	2011-11_
8.6	FT250.55.017	油尺焊合	OIL DIPSTICK WELDMENT	1	2011-11_
9	JBZQ4454-36X42	密封垫	SEAL GASKET	1	2011-11_

FT250.56.001 悬挂机构总成-1

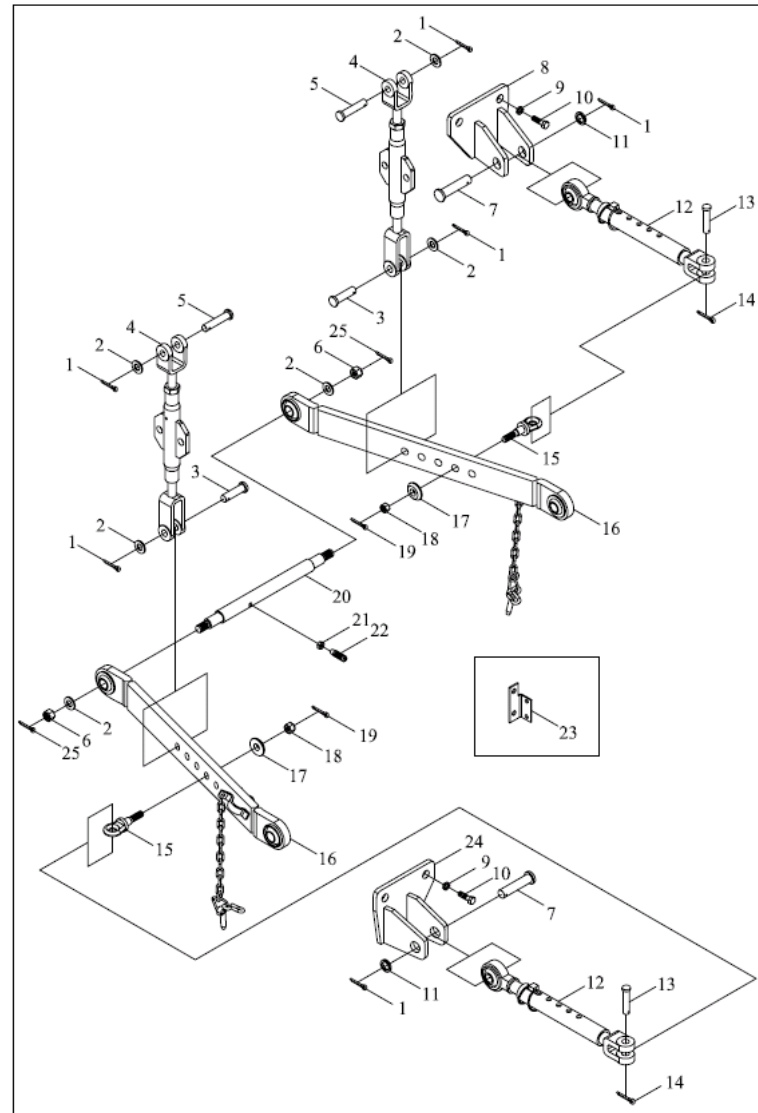

FT250.56.001-1 56.1-悬挂机构总成-1 SUSPENSION MECHANISM ASSEMBLY-1

标号 No.	代号 Code	名称 Description		数量 Quantity	备注 Remark
0	FT250.56.148	限位杆后联接销	LIMITING ROD REAR CONNECTING PIN	2	2014-07_
1	GBT91-4X28-A0P	开口销	PIN	6	2011-11_
10	GBT5783-M14X35-A3L	六角头螺栓	BOLT	4	2011-11_
11	FT250.56.103	套	COVER	4	2011-11_
12	FT250.56.016a	限位杆总成	LIMIT ROD ASSEMBLY	2	2011-11_
13	GBT882-B16X55-A0P	销轴	PIN	2	2011-11_
14	GBT91-5X32-A0P	开口销	PIN	2	2011-11_
15	FT250.56.138	限位杆后联接销	LIMITING ROD REAR CONNECTING PIN	2	2004-01_
15	FT250.56.138a	限位杆后联接销	LIMITING ROD REAR CONNECTING PIN	2	2011-11_
16	FT250.56.013	下拉杆总成	LOWER PULL ROD ASSEMBLY	2	2011-11_
17	FT250.56.139a	圆板	ROUND BOARD	2	2011-11_
17	FT250.56.139	圆板	ROUND BOARD	2	2004-01_
18	GBT6178-M14-A3L	开槽螺母	SLOTTED NUT	2	2011-11_
19	GBT91-3.2X28-A0P	开口销	PIN	2	2004-01_
2	GBT97.1-16-A0P	垫圈	WASHER	6	2011-11_
20	FT250.56.102	下拉杆固定轴	LOWER PULL ROD FIXING SHAFT	1	2011-11_
21	GBT6172.1-M12-A3L	螺母	NUT	1	2011-11_
22	FT250.56.125	止动螺钉	THRUST SCREW	1	2004-01_
22	FT250.56.125	止动螺钉	THRUST SCREW	1	2004-01_
23	FT250.56.144	油管支架	OIL PIPE BRACKET	1	2011-11_
24	FT250.56.018	左限位杆支架焊合件	LEFT LIMITING ROD BRACKET WELDMENT	1	2011-11_
25	GBT91-4X36-A0P	开口销	PIN	2	2011-11_
3	FT250.56.104	提升杆下联接销	LIFTING ROD LOWER CONNECTING PIN	2	2011-11_
4	FT250.56.011	提升杆总成	LIFTING ROD ASSEMBLY	2	2011-11_
5	FT250.56.101	提升杆上联接销	LIFTING ROD UPPER CONNECTING PIN	2	2004-01_

FT250.56.001 悬挂机构总成-1

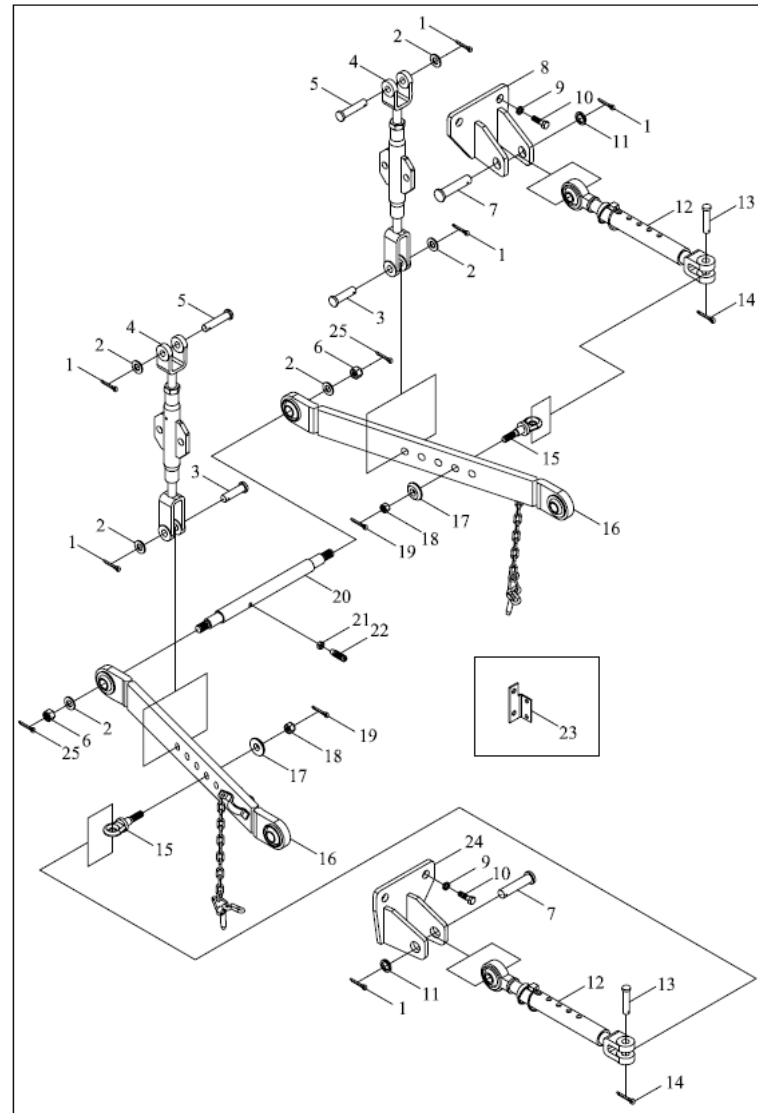

FT250.56.001-1 56.1-悬挂机构总成-1(续)

标号 No.	代号 Code	名称 Description		数量 Quantity	备注 Remark
5	FT250.56.101a	提升杆上联连接销	LIFTING ROD UPPER CONNECTING PIN	2	2008-01_
6	GBT6178-M16-A3L	1型六角开槽螺母	NUT (PAGE81)	2	2011-11_
7	FT250.56.106	限位杆连接销	LIMITING ROD CONNECTING PIN	2	2011-11_
8	FT250.56.015	右限位杆支架焊合件	RIGHT LIMITING ROD BRACKET WELDMENT	1	2011-11_
9	GBT93-14-A0P	弹簧垫圈	SPRING WASHER	4	2011-11_
9	GBT93-14-A0P	弹簧垫圈	SPRING WASHER	4	2011-11_

FT250.56.001 悬挂机构总成-2

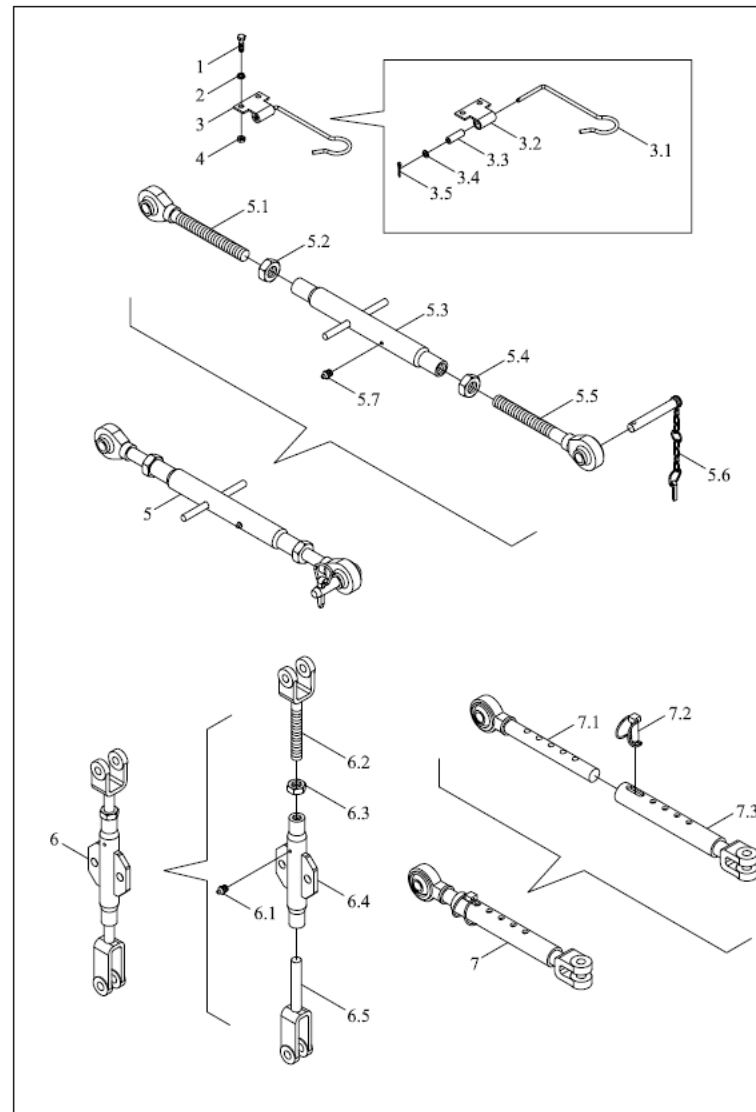

FT250.56.001-2 56.2-悬挂机构总成-2 SUSPENSION MECHANISM ASSEMBLY-2

标号 No.	代号 Code	名称 Description		数量 Quantity	备注 Remark
1	GBT5783-M8X16-A2L	螺栓	BOLT	2	2011-11_
2	GBT93-8-AOP	弹簧垫圈	SPRING WASHER	2	2011-11_
3	TE300.56.6	上拉杆固定卡组合	UPPER PULL ROD FIXED CLIP COMBINATION	1	2011-11_
3.1	TE300.56.6-02	上拉杆固定卡	UPPER PULL ROD FIXING CLIP	1	2011-11_
3.2	TE300.56.6-01	固定座	FIXING SEAT	1	2011-11_
3.3	TE300.56.6-03	尼龙衬套	NYLON BUSH	1	2011-11_
3.4	GBT96.1-6-A0P	垫圈	WASHER	1	2011-11_
3.5	GBT91-2X14-A0P	开口销	PIN	1	2011-11_
4	GBT6170-8-A2L	1型六角螺母	NUT	2	2011-11_
5	FT250.56.012a	上拉杆总成	UPPER PULL ROD ASSEMBLY	1	2011-11_
5.1	FT250.56.017	上拉杆前调节杆总成	UPPER PULL ROD FRONT ADJUSTING ROD ASSEMBLY	1	2011-11_
5.2	GBT6171-M22X1.5-A3L	1型六角螺母	NUT	1	2011-11_
5.3	FT250.56.031	调节螺管焊合	ADJUSTING SCREW WELDMENT	1	2011-11_
5.4	GBT6171-M22X1.5LH-A3L	1型六角螺母	NUT	1	2011-11_
5.5	FT250.56.019	上拉杆后调节杆总成	UPPER PULL ROD REAR ADJUSTING ROD ASSEMBLY	1	2011-11_
5.6	FT300.56A.113	锁销链总成	LOCKING PIN CHAIN ASSEMBLY	1	2011-11_
6	FT250.56.011	提升杆总成	LIFTING ROD ASSEMBLY	1	2011-11_
6.1	JBT7940.1-M6	直通式压注油杯	STRAIGHT PRESSURE FILLING OIL CUP	1	2011-11_
6.2	FT250.56.107	提升杆上联接叉	LIFTING ROD UPPER CONNECTING FORK	1	2004-01_
6.2	FT250.56.107a	提升杆上联接叉	LIFTING ROD UPPER CONNECTING FORK	1	2008-01_
6.3	GBT6171-M18X1.5-A3L	1型六角螺母	NUT	1	2011-11_
6.4	FT250.56.022a	提升杆螺管总成	LIFTING ROD SOLENOID ASSEMBLY	1	2008-01_
6.4	FT250.56.022	提升杆螺管总成	LIFTING ROD SOLENOID ASSEMBLY	1	2004-01_
6.5	FT250.56.108	提升杆下联接叉	LIFTING ROD LOWER CONNECTING FORK	1	2004-01_
6.5	FT250.56.108a	提升杆下联接叉	LIFTING ROD LOWER CONNECTING FORK	1	2008-01_

FT250.56.001 悬挂机构总成-2

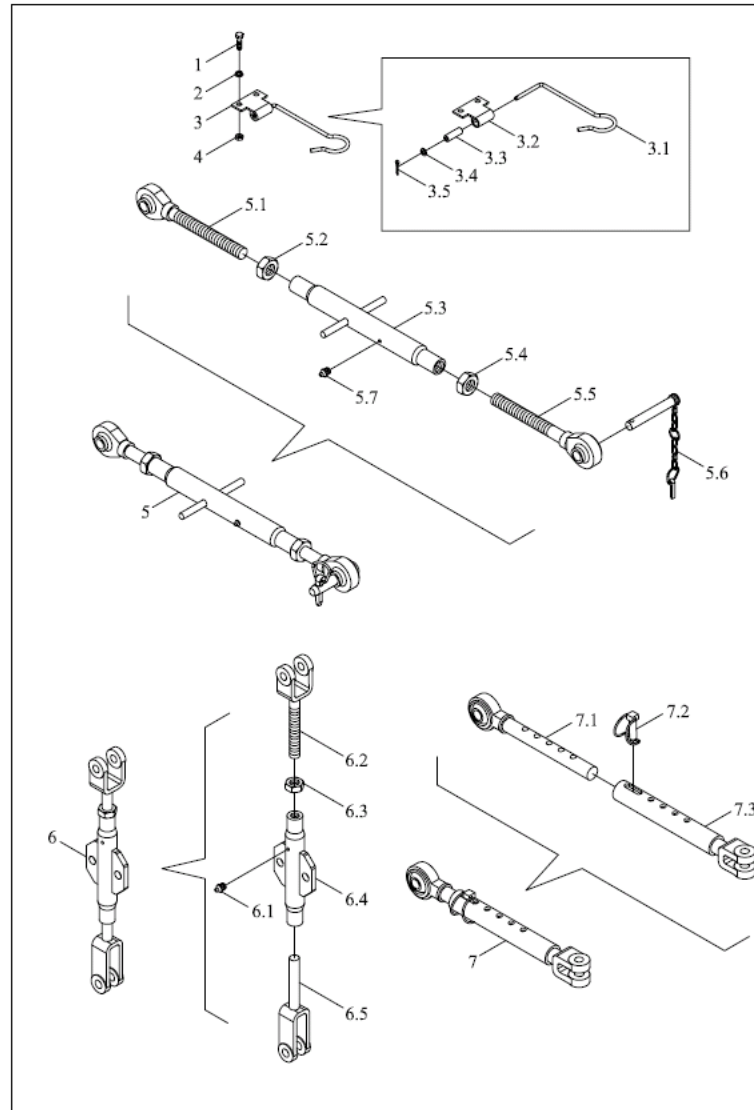

FT250.56.001-2 56.2-悬挂机构总成-2(续)

标号 No.	代号 Code	名称 Description		数量 Quantity	备注 Remark
7	FT250.56.016a	限位杆总成	LIMIT ROD ASSEMBLY	1	2011-11_
7.1	FT250.56.023a	伸缩导杆总成	EXTENSIBLE GUIDE ROD ASSEMBLY	1	2008-02_
7.1	FT250.56.023B	伸缩导杆总成	EXTENSIBLE GUIDE ROD ASSEMBLY	1	2011-07_
7.1	FT250.56.023	伸缩导杆总成	EXTENSIBLE GUIDE ROD ASSEMBLY	1	2004-01_
7.11	FT250.56.126b	套管	SLEEVE	1	2011-07_
7.2	FT250.56.021a	限位杆锁销总成	LIMIT ROD LOCK PIN ASSEMBLY	1	2011-11_
7.3	FT250.56.025a	伸缩套管总成	EXTENSIBLE PIPE ASSEMBLY	1	2004-01_
7.3	FT250.56.025b	伸缩套管总成	EXTENSIBLE PIPE ASSEMBLY	1	2008-02_
7.7	FT250.56.129	螺纹套管	THREAD SLEEVE	1	
7.8	FT250.56.126	伸缩导管	EXTENSIBLE GUIDE PIPE		
7.9	FT250.56.126a	伸缩导管	EXTENSIBLE GUIDE PIPE	1	2008-02_

FT250.57.001 分配器总成

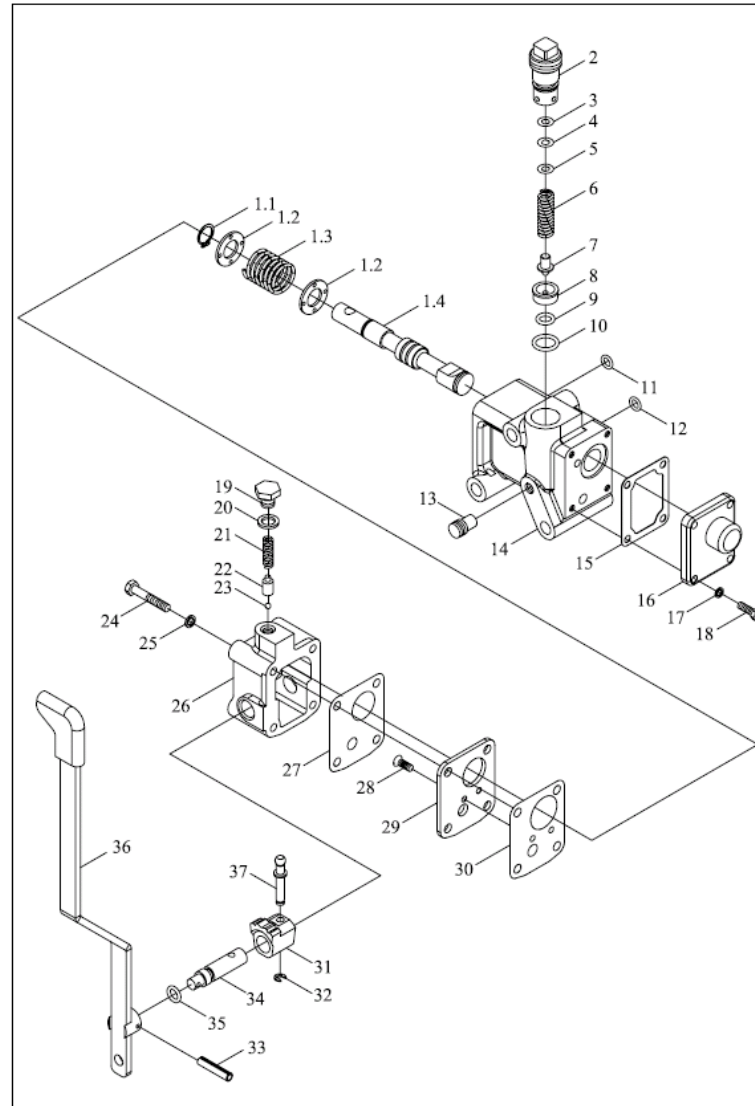

FT250.57.001 57-分配器总成

标号 No.	代号 Code	名称 Description		数量 Quantity	备注 Remark
1	FT250.57.010	滑阀总成	SLIDING VALVE ASSEMBLY	1	2011-11_
1.1	GBT894.1-15	轴用弹性挡圈	SNAP RING	1	2011-11_
1.2	FT250.57.115	弹簧挡片	SPRING RETAINER PIECE	2	2011-11_
1.3	FT250.57.114	滑阀回位弹簧	SLIDING VALVE RETURN SPRING	1	2011-11_
1.4	FT250.57.113	滑阀	SLIDING VALVE	1	2011-11_
10	GBT3452.1-15X2.65G	液压气动用O形橡胶密封圈	O-SEAL RING	1	2011-11_
11	GBT3452.1-13.2X2.65G	液压气动用O形橡胶密封圈	O-SEAL RING	1	2011-11_
12	GBT3452.1-19X2.65G	液压气动用O形橡胶密封圈	O-SEAL RING	1	2011-11_
13	JBZQ4447-Z1-8	螺塞	SCREW PLUG	1	2011-11_
14	FT250.57.104	分配器壳体	DISTRIBUTOR HOUSING	1	2011-11_
15	FT250.57.103	前盖纸垫	FRONT COVER PAPER GASKET	1	2011-11_
16	FT250.57.102	前盖	FRONT COVER	1	2011-11_
17	GBT93-5	垫圈	WASHER	4	2004-01_
18	GBT5781-M5X16-A2L	六角头螺栓	BOLT	4	2004-01_
19	FT250.57.123	螺堵	SCREW PLUG	1	2011-11_
2	FT250.57.128	压紧螺塞	PRESSURE PLUG	1	2011-11_
20	FT250.57.124	调整垫片	ADJUSTING WASHER	1	2011-11_
21	FT250.57.122	定位弹簧	LOCATING SPRING	1	2011-11_
22	FT250.57.121	定位弹簧座	LOCATING SPRING SEAT	1	2011-11_
23	GBT308-5-G100b	钢球	BALL	1	2004-01_
24	GBT5780-M6X55-A1L	六角头螺栓	BOLT	4	2004-01_
25	GBT93-6	垫圈	WASHER	4	2004-01_
26	FT250.57.108	后盖	COVER REAR	1	2011-11_
27	FT250.57.107	后盖纸垫	REAR COVER GASKET	1	2011-11_
28	GBT68-M4X10-A2L	开槽双头螺钉		2	

FT250.57.001 分配器总成

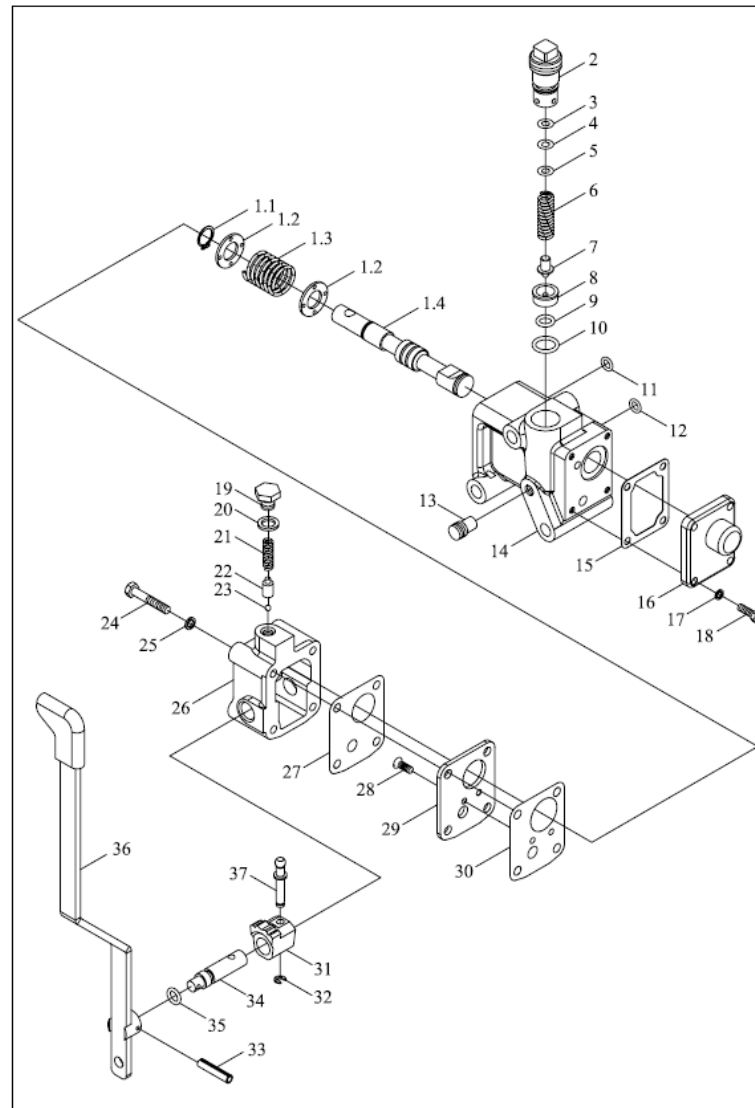

FT250.57.001 57-分配器总成(续)

标号 No.	代号 Code	名称 Description		数量 Quantity	备注 Remark
29	FT250.57.106	挡板	RETAINER PLATE	1	2011-11_
3	FT250.57.110	调整垫片	ADJUSTING WASHER	1	2011-11_
30	FT250.57.105	挡板纸垫	RETAINER PLATE PAPER GASKET	1	2011-11_
31	FT250.57.119	定位块	LOCATING BLOCK	1	2011-11_
32	GBT896-4	开口挡圈	SNAP RING	1	2011-11_
33	GBT879-4X22	销	PIN	1	2011-11_
34	FT250.57.109	手柄轴	HANDLE SHAFT	1	2011-11_
34	FT250.57.109	手柄轴	HANDLE SHAFT	1	2011-11_
35	GBT3452.1-9.5X2.65G	液压气动用O形橡胶密封圈	O-SEAL RING	1	2011-11_
36	FT250.57.011	手柄总成	HANDLE ASSEMBLY	1	2011-11_
36	FT250.57.011	手柄总成	HANDLE ASSEMBLY	1	2011-11_
37	FT250.57.120	拨销	DIAL PIN	1	2011-11_
4	FT250.57.111	调整垫片	ADJUSTING WASHER	1	2011-11_
5	FT250.57.112	调整垫片	ADJUSTING WASHER	1	2011-11_
6	FT250.57.129	安全阀弹簧	SAFETY VALVE SPRING	1	2011-11_
7	FT250.57.131	安全阀阀芯	SAFETY VALVE CORE	1	2011-11_
8	FT250.57.101	安全阀阀座	SAFETY VALVE SEAT	1	2011-11_
9	GBT3452.1-9X2.65G	液压气动用O形橡胶密封圈	O-SEAL RING	1	2011-11_

FT254.58.001 多路阀油泵油管总成-1

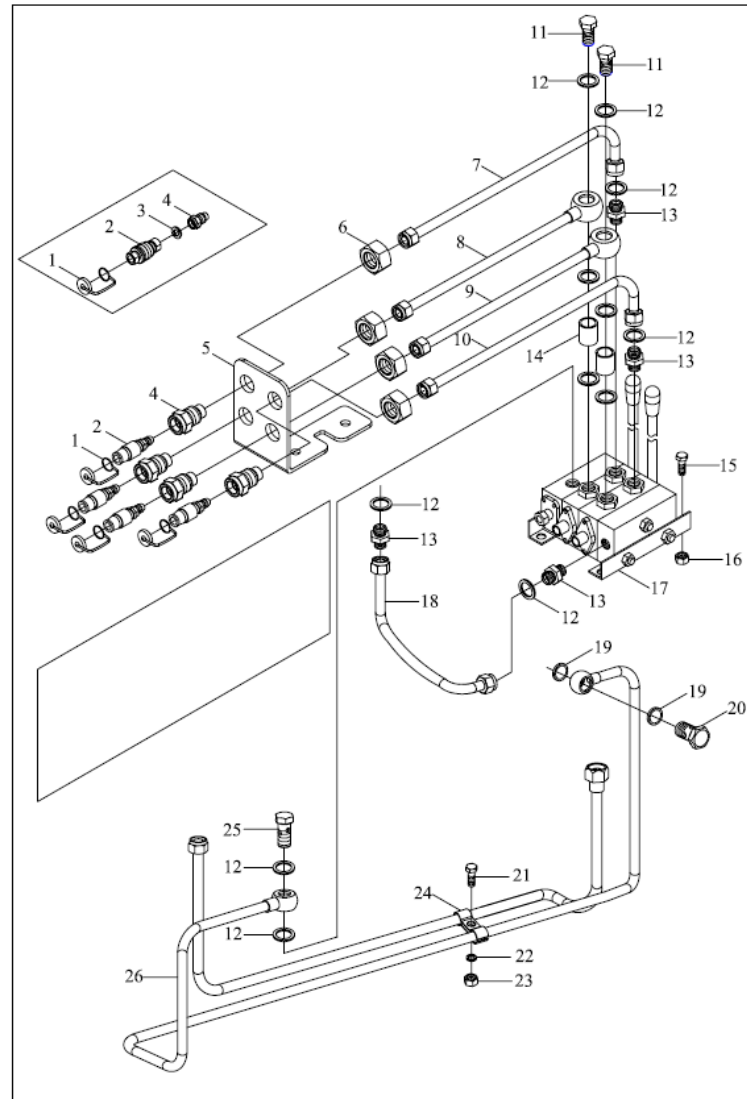

FT254.58.001-1 58.1-多路阀油泵油管总成-1 MULTI-WAY VALVE OIL PUMP OIL PIPE ASSEMBLY-1

标号 No.	代号 Code	名称 Description	数量 Quantity	备注 Remark
1	FT354.58A.103	防尘盖	4	2011-11_
10	FT254.58.016	输出油管总成2	1	2011-11_
11	FT654.58.113	空心螺栓-4	2	2011-11_
12	JBT982-18	组合密封垫圈	9	2011-11_
12	JBT982-18	组合密封垫圈	9	2011-11_
13	FT804.58.112	卡套式端直通接头体	4	2011-11_
14	FT654.58.114	厚垫圈-2	2	2011-11_
15	GBT5781-M10X25	六角头螺栓	4	2011-11_
15	GBT5781-M10X25	六角头螺栓	4	2011-11_
16	GBT41-M10	六角螺母	4	2011-11_
17	FT254.58.017	多路换向阀	1	2011-11_
18	FT254.58.011	分配器进油管总成	1	2011-11_
19	JBT982-20	组合密封垫圈	2	2011-11_
2	FT354.58A.030	快换接头	4	2011-11_
2.1	FT654.58.010	快换接头	4	2011-11_
20	FT650.40.102	空心螺栓M20X1.5	1	2011-11_
22	GBT93-6	垫圈	2	2011-11_
23	GBT6170-M6	螺母	2	2011-11_
24	FT254.58.018	油管夹与胶垫胶合	4	2011-11_
25	FT700.58G.103	空心螺栓-2	1	2011-11_
26	FT254.58.014	多路阀进油管焊合	1	2011-11_
3	FT654.58.106a	垫圈	4	2011-11_
4	FT754.58.102	油管接头	4	2011-11_
4.1	FT654.58B.101a	油管接头	4	2011-11_
5	FT254.58.101	油管支架	1	2011-11_

FT254.58.001 多路阀油泵油管总成-1

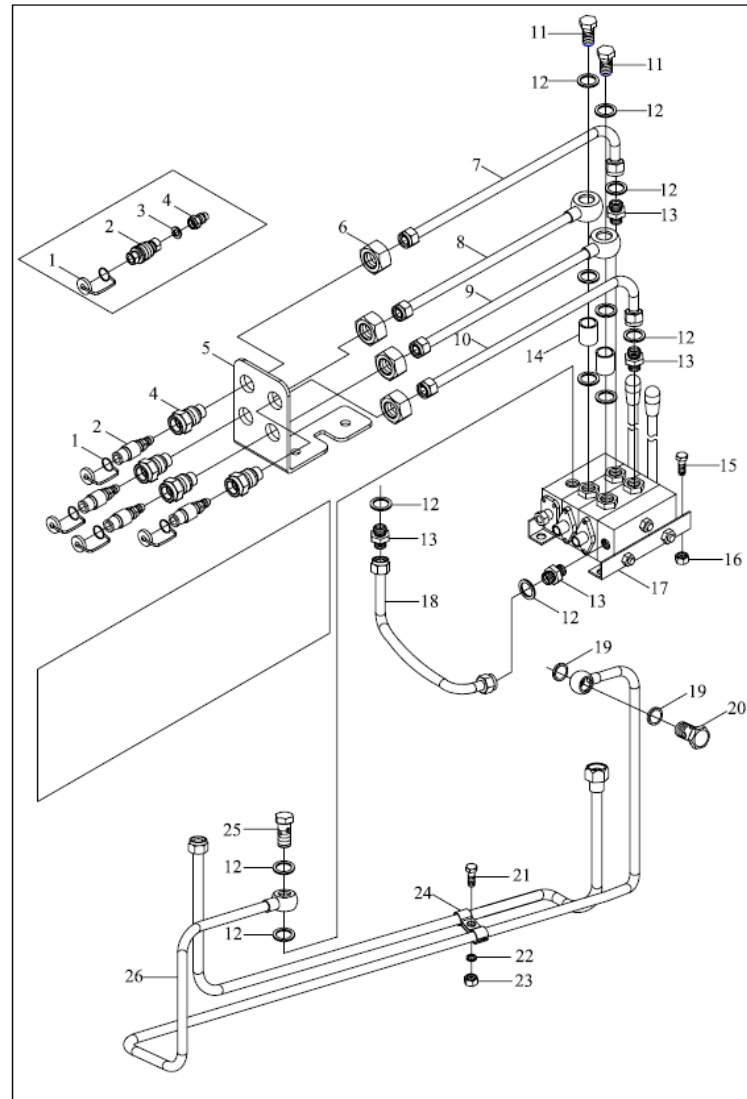

FT254.58.001-1 58.1-多路阀油泵油管总成-1(续)

标号 No.	代号 Code	名称 Description		数量 Quantity	备注 Remark
6	GBT6173-M27X2-Zn.D	六角薄螺母	NUT	4	2011-11_
7	FT254.58.015	输出油管总成1	OIL OUTLET PIPE ASSEMBLY-1	1	2011-11_
8	FT254.58.022	输出油管总成1	OIL OUTLET PIPE ASSEMBLY-1	1	2011-11_
9	FT254.58.023	输出油管总成2	OIL OUTLET PIPE ASSEMBLY 2	1	2011-11_

FT254.58.001 多路阀油泵油管总成-2

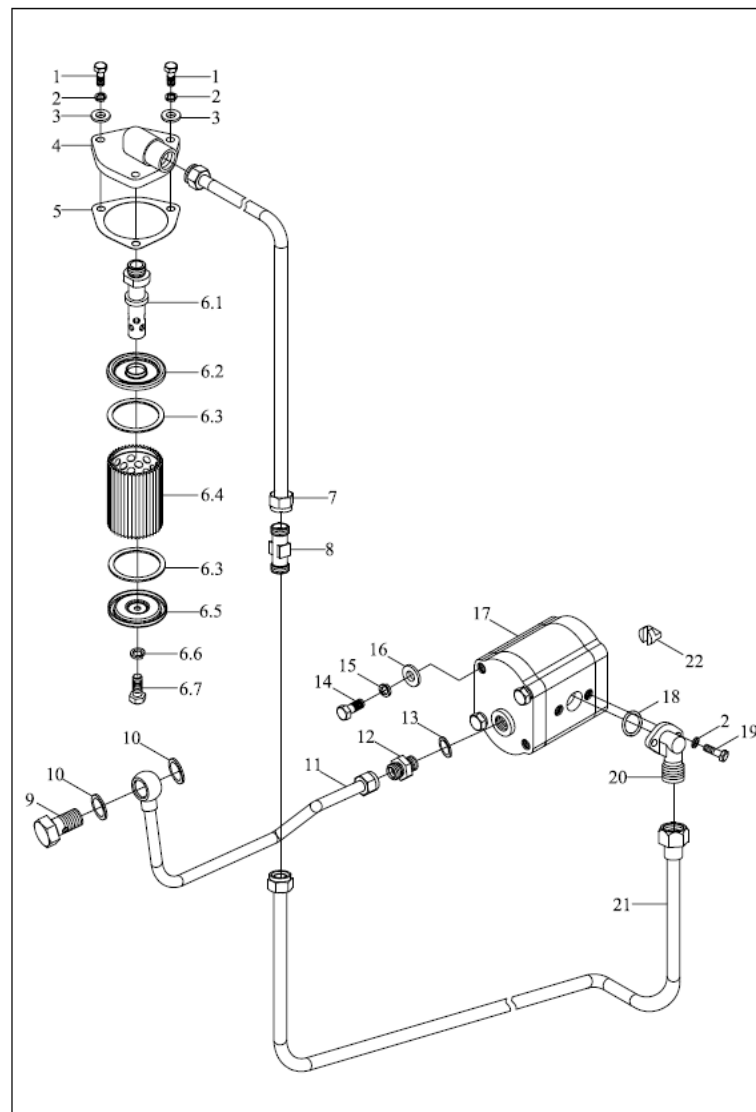

FT254.58.001-2 58.2-多路阀油泵油管总成-2 MULTI-WAY VALVE OIL PUMP OIL PIPE ASSEMBLY-2

标号 No.	代号 Code	名称 Description		数量 Quantity	备注 Remark
1	GBT5783-M8X25	螺栓	BOLT	3	2011-11_
10	JBT982-24	组合密封垫圈	COMBINED SEAL GASKET	2	2011-11_
11	FT254.58.013	压力油管总成	PRESSURE OIL PIPE ASSEMBLY	1	2011-11_
12	FT804.58.112	卡套式端直通接头体	STRAIGHT PIPE JOINT BODY	1	2011-11_
13	JBT982-18	组合密封垫圈	COMBINED SEAL GASKET	1	2011-11_
13	JBT982-18	组合密封垫圈	COMBINED SEAL GASKET	1	2011-11_
15	GBT93-10	垫圈10	WASHER 10	2	2011-11_
16	GBT97.1-10	垫圈10	WASHER 10	2	2011-11_
17	FT254.58.010	齿轮泵	GEAR PUMP	1	2011-11_
18	GBT3452.1-18X2.65G	液压气动用O形橡胶密封圈	O-SEAL RING	1	2011-11_
19	GBT5783-M8X30	六角头螺栓	BOLT	2	2011-11_
2	GBT93-8	垫圈8	WASHER 8	5	2011-11_
20	FT254.58.126	前置油泵油管接头	FRONT OIL PUMP PIPE JOINT	1	2011-11_
21	FT254.58.021	吸油管焊合2	OIL SUCTION PIPE WELDMENT 2	1	2011-11_
22	FT254.58.127	十字滑块	CROSS SLIDE BLOCK	1	2011-11_
3	GBT97.1-8	垫圈	WASHER	3	2011-11_
4	FT254.58.115	滤油器盖	OIL FILTER COVER	1	2011-11_
5	FT254.58.114	纸垫	GASKET 0.5	1	2011-11_
6	FT254.58.019	吸油滤清器	OIL ABSORPTION FILTER	1	2011-11_
6.1	FT254.58.116	滤油器中心油管	OIL FILTER CENTRAL PIPE	1	2011-11_
6.2	FT254.58.117	滤网上盖	FILTER MESH UPPER COVER	1	2011-11_
6.3	FT254.58.119	密封垫片	SEAL WASHER	2	2011-11_
6.4	FT254.58.020	滤网总成	FILTER MESH ASSEMBLY	1	2011-11_
6.5	FT254.58.118	滤网下盖	FILTER MESH LOWER COVER	1	2011-11_
6.6	GBT97.1-6	垫圈 6	WASHER 6	1	2011-11_

FT254.58.001 多路阀油泵油管总成-2

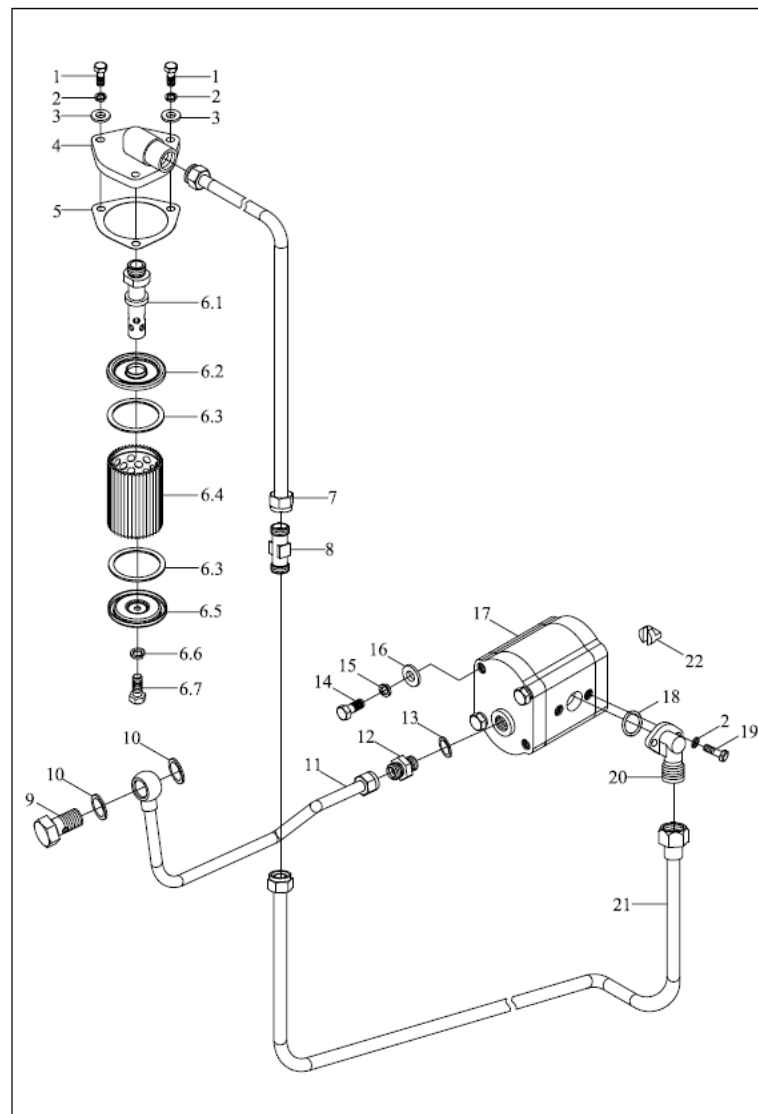

FT254.58.001-2 58.2-多路阀油泵油管总成-2(续)

标号 No.	代号 Code	名称 Description		数量 Quantity	备注 Remark
7	FT254.58.012	吸油管焊合1	OIL SUCTION PIPE WELDMENT 1	1	2011-11_
8	FT254.58.102	油管接头1	OIL PIPE JOINT 1	1	2011-11_
9	FT254.58.132	空心螺栓	HOLLOW BOLT	1	2011-11_

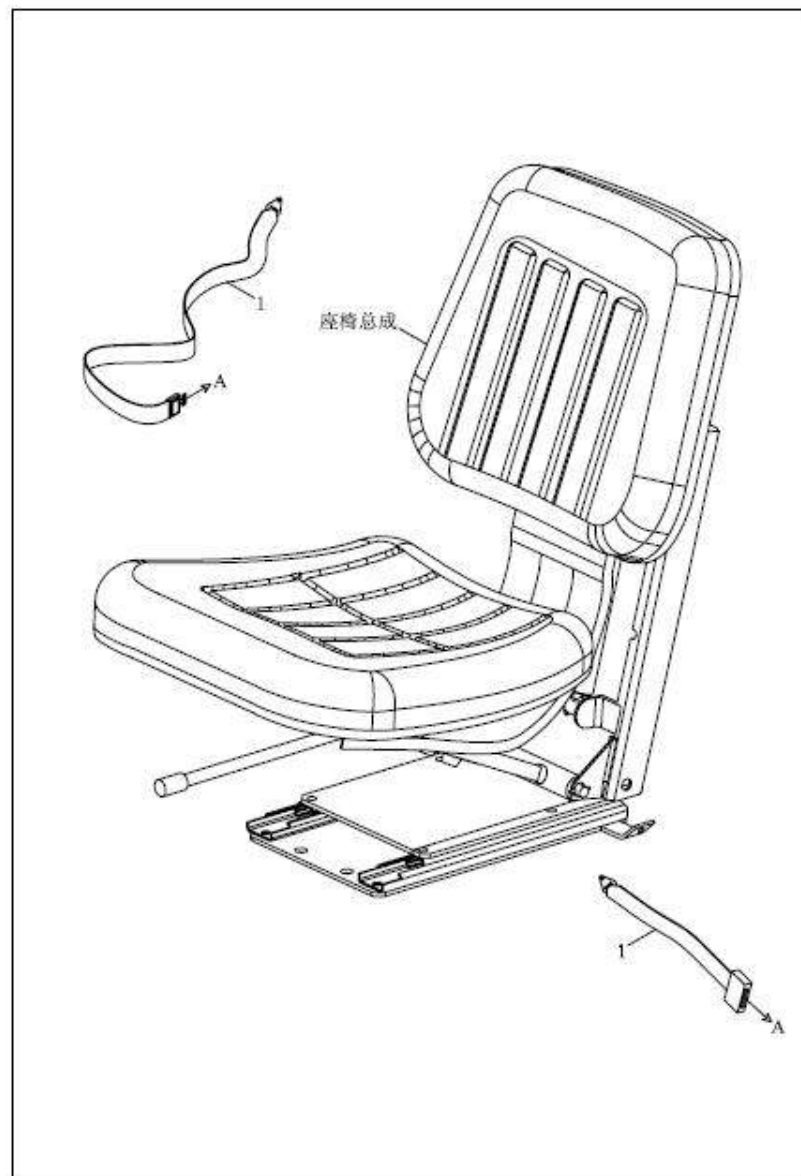

FT250.62.001ZC 62-安全带总成 62-SAFETY BELT ASSEMBLY

标号 No.	代号 Code	名称 Description		数量 Quantity	备注 Remark
1	FT250.62.001	安全带安装总成	SAFETY BELT INSTALLATION ASSEMBLY	1	2004-01_

FT250.74.001 前配重总成

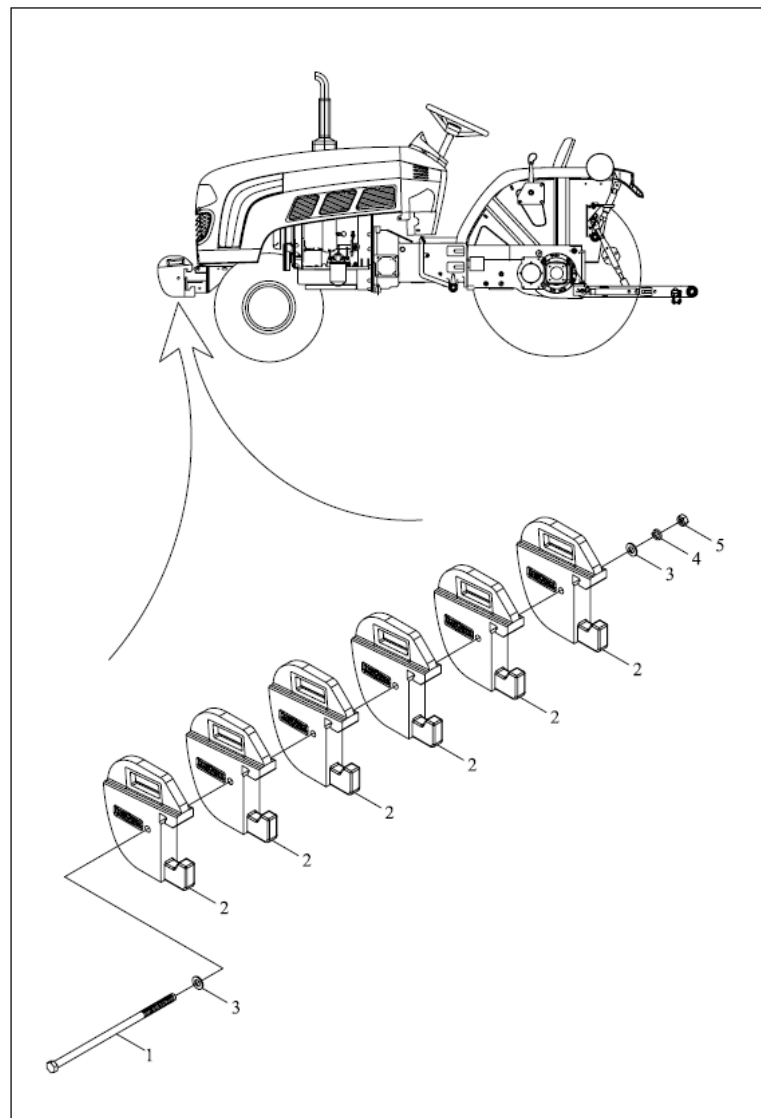

FT250.74.001 74-前配重总成 74-FRONT BALLAST ASSEMBLY

标号 No.	代号 Code	名称 Description		数量 Quantity	备注 Remark
1	FT250.74.102	配重固定螺栓	BALLAST FIXING BOLT	1	2011-11_
2	FT250.74.101a	前配重	FRONT BALLAST	6	2006-12_
3	GBT97.1-12-A0P	平垫圈	WASHER	2	2011-11_
4	GBT93-12-A0P	弹簧垫圈	SPRING WASHER	1	2011-11_
5	GBT6170-M12-A3L	螺母	NUT	1	2011-11_

FT250.21B.011 离合器总成

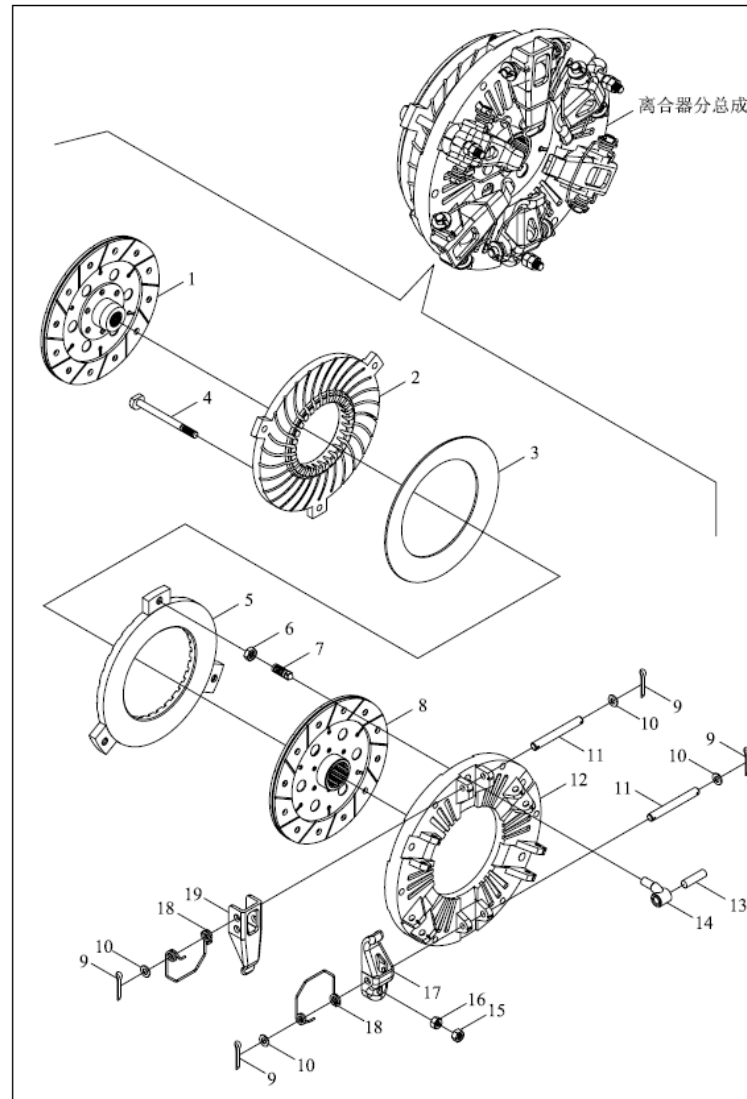

FT250.21B.011 离合器分总成 CLUTCH SUBASSEMBLY

标号 No.	代号 Code	名称 Description		数量 Quantity	备注 Remark
1	FT250.21B.014	副摩擦片总成	AUXILIARY FRICTION PIECE ASSEMBLY	1	
1	FT200.21B.014	副离合器从动盘总成	AUXILIARY CLUTCH DRIVEN PLATE ASSEMBLY	1	
10	GBT848-10-Zn.D	平垫	WASHER	12	
11	FT300.21B.111	长销	LONG PIN	6	
12	FT250.21B.115	离合器盖	CLUTCH COVER	1	
12	FT200.21B.115	离合器盖	CLUTCH COVER	1	
13	FT300.21B.109	销轴	PIN	3	
14	FT250.21B.114	顶杆	TOP ROD	1	
14	FT200.21B.114	主离合器分离推杆	MAIN CLUTCH RELEASE PULL ROD	1	
15	GBT6171-M8X1-Zn.D	1型六角螺母	NUT	3	
16	FT300.21B.105	球头螺母	BALL NUT	3	
16	FT300.21B.105	球头螺母	BALL NUT	3	
17	FT200.21B.118	副离合器分离杠杆	AUXILIARY CLUTCH RELEASE LEVER	3	
17	FT250.21B.118	副离合器分离杠杆	AUXILIARY CLUTCH RELEASE LEVER	3	
18	FT250.21B.121	分离杆弹簧	RELEASE ROD SPRING	6	
18	FT200.21B.116	离合器分离杠杆弹簧	CLUTCH RELEASE LEVER SPRING	6	
19	FT200.21B.117	主离合器分离杠杆	MAIN CLUTCH RELEASE LEVER	3	
19	FT200.21B.117	主离合器分离杠杆	MAIN CLUTCH RELEASE LEVER	3	
19	FT250.21B.117	主离合器分离杠杆	MAIN CLUTCH RELEASE LEVER	3	
2	FT250.21B.112	副离合器压盘	AUXILIARY CLUTCH PRESSURE PLATE	1	
3	FT250.21B.105	碟形弹簧	DISC SPRING	1	
3	FT250.21B.105	碟形弹簧	DISC SPRING	1	
4	FT400.21B.104	副离合器拉杆	AUXILIARY CLUTCH PULL ROD	3	
5	FT250.21B.126	主压板	PRESSURE PLATE	1	2011-11_
5	FT250.21B.113	主离合器压盘	MAIN CLUTCH PRESSURE PLATE	1	

FT250.21B.011 离合器总成

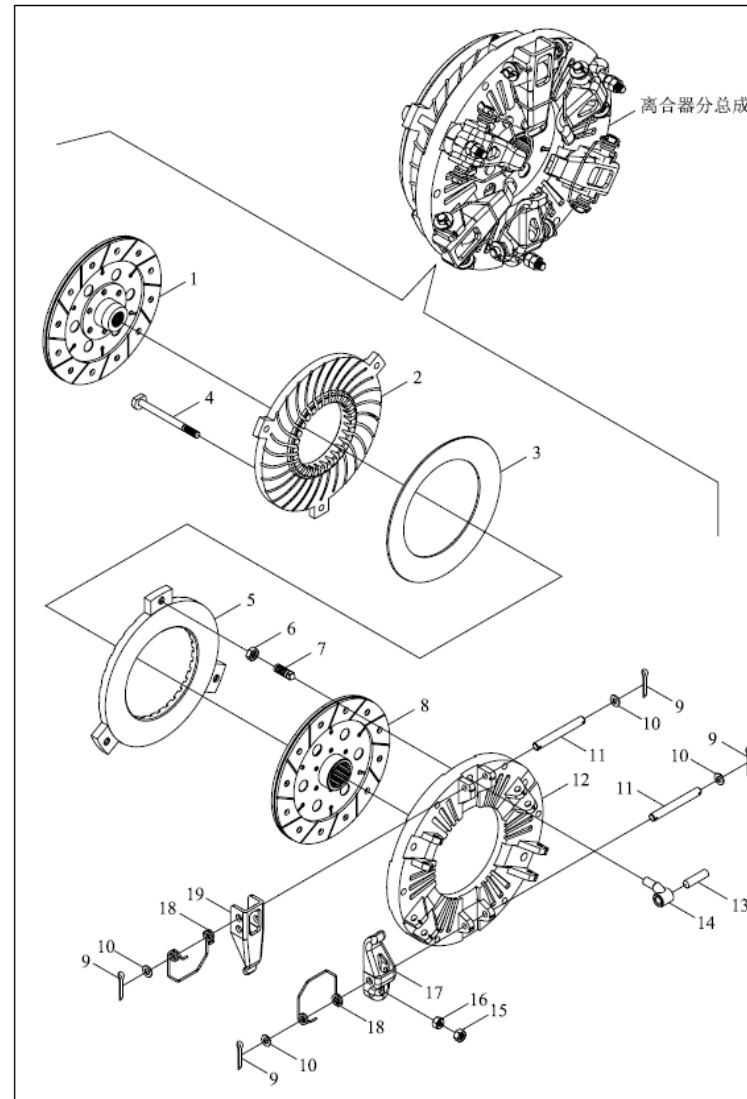

FT250.21B.011 离合器分总成(续)

标号 No.	代号 Code	名称 Description		数量 Quantity	备注 Remark
5	FT200.21B.113	主离合器压盘	MAIN CLUTCH PRESSURE PLATE	1	
6	GBT6173-M10X1-Zn.D	六角薄螺母	NUT	3	
6	GBT6173-M10X1-Zn.D	六角薄螺母	NUT	3	
7	FT200.21B.110	主离合器调整螺钉	MAIN CLUTCH ADJUSTING SCREW	3	
8	FT200.21B.015/017	离合器主从动盘	в е д о м ы й д и с к	1	
8	FT250.21B.017	主离合器从动盘总成	MAIN CLUTCH DRIVEN PLATE ASSEMBLY	1	
9	GBT91-3.2X20-A0P	开口销	PIN	12	
9	GBT91-3.2X20-A0P	开口销	PIN	12	

