

## Operation Description

### 2. Operator Instruction



**Note:** operating the tractor properly can bring efficiency of the tractor into full play to reduce tractor wear and prevent an accident and ensure operator to complete farm and road operations fast, efficiently, in low consumption and safety mode

Table 2-1 Common symbols

Symbols	Definition	Symbols	Definition	Symbols	Definition
	Safety warning identifier		Four-wheel drive		Horn
	High beam		Dipped headlight		Quick
	Engine oil pressure		Charging and discharging indication		Slowly
	Steering light indicator		Syringe		Position lamp
	Engine preheated		Rear windscreen wiper		wiper
	Air filter blockage warning		Hydraulic oil air separator		Pneumatic braking invalid/failure
	Engine coolant temperature		Quantity of fuel oil		Parking brake
	Differential lock		Warning for danger		Warning lamp

# Operation Description

## 2.1 Description of Products

The following information will help you use, maintain, and troubleshoot the Foton FT series tractors, including: FT20 and FT25

The Foton FT series of tractors is a medium-sized tractor that can be used in a variety of land types. The tractor has a compact structure and is easy to control with responsive steering, a high lift capacity and low maintenance.

## 2.2 Tractor Operating Mechanism and Instrumentation

### 2.2.1 Tractor Operation Mechanism

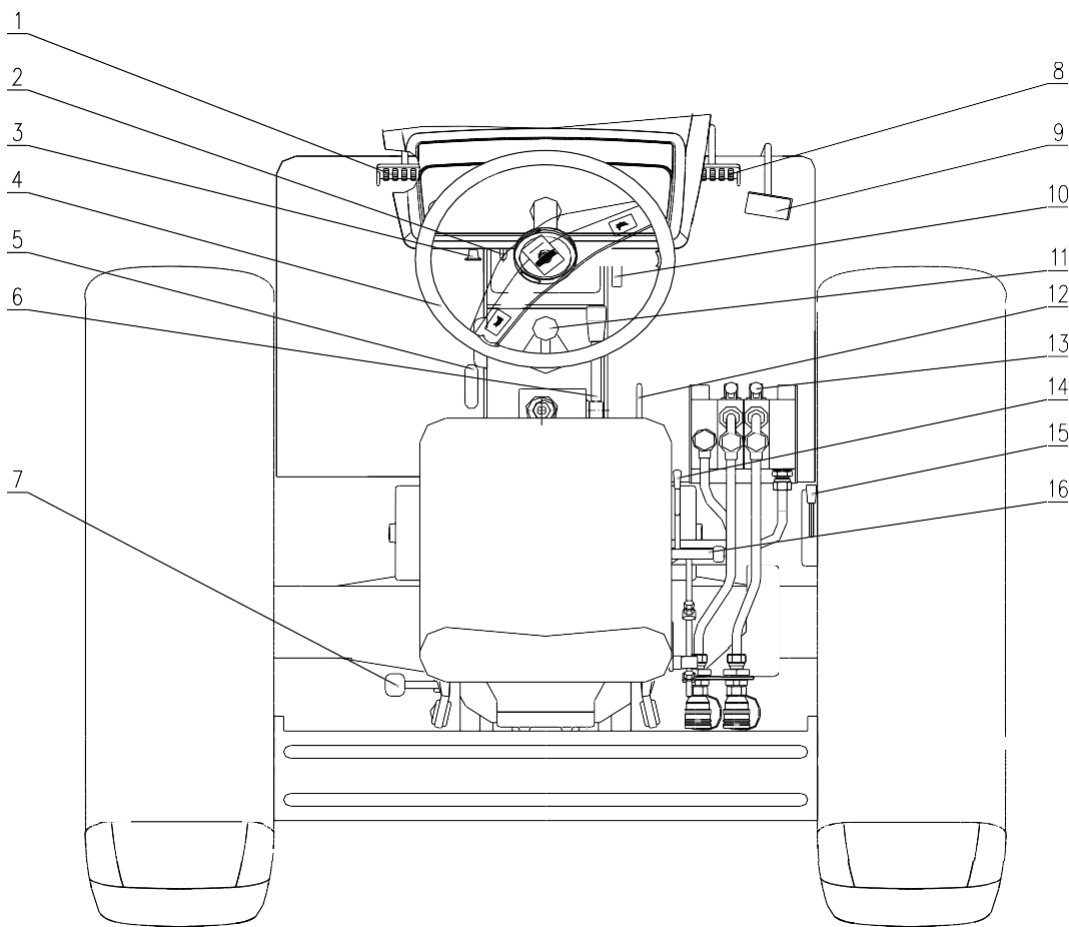

Figur. 2-1 Tractor Operation Mechanism

1. Clutch pedal
2. Decompression lever
3. Ignition-cut-off pull rod
4. Steering wheel
5. Front drive axle operation handle
6. Auxiliary shift lever
7. Power take-off (PTO) speed lever
8. Parking brake pedal
9. Foot-operated throttle pedal
10. Parking brake handle
11. Main shift lever
12. Power take-off (PTO) lever
13. Multi-way valve control handle
14. Differential lock control handle
15. Hand operated throttle control handle
16. Distributor control handle

# Operation Description

## Instrumentation and Switches

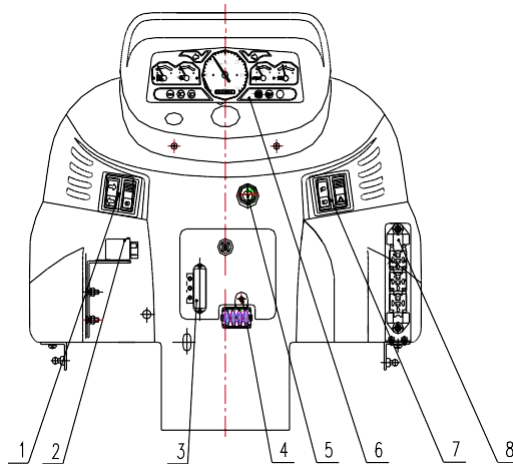

Figure 2-2 Instrumentation and Switches

1. Left rocker switch assembly
2. Start relay
3. Pressure regulator
4. Fuse box assembly
5. Ignition switch
6. Combined instrument
7. Right rocker switch assembly
8. Fuse box assembly

**IMPORTANT NOTES:** Observe all warning lights and pay attention to the instrument panel during operations.

### Fuel Gauge

The fuel gauge indicates the amount of fuel in the tank. When the indicator is in the far right position, it indicates the fuel tank is full of fuel; when the indicator is in the left red area, it means the fuel tank is low and should be filled immediately.

Note: Never allow tractor to run out of fuel, it can damage the fuel pump.

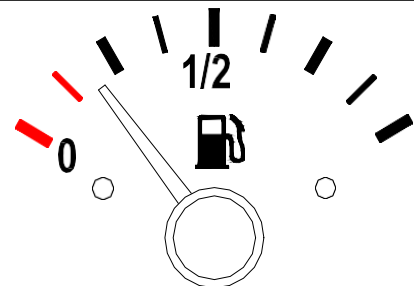

Figure 2-3 Fuel Gauge

### Water Temperature Gauge

The Water Temperature Gauge marks the engine cooling liquid temperature, moving from left to right with the red area indicating high temperature.

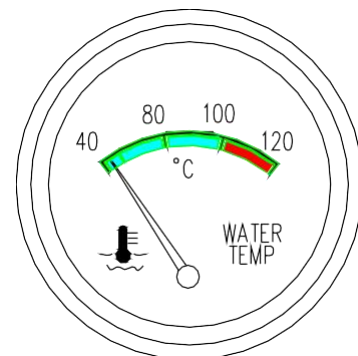

Figure 2-4 Water Temperature Gauge

## Operation Description

### Engine tachometer

The engine tachometer shows the operating rotary speed of the engine once the tractor is started. Tractor running hours are displayed in the lower box.

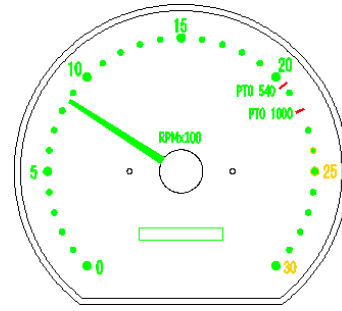

Figure 2-5

Engine Tachometer

### Amp meter

The Amp meter is used to indicate the status of the battery. The indicator will be in the + when the battery is properly charged.

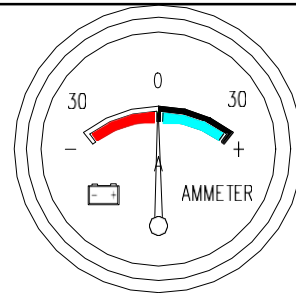
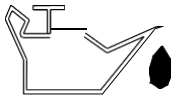

Figure 2-6 Amp meter,

### Engine Oil Pressure Warning Lamp is Red.



When the key is turned to the ignition position, the lamp is lit. After the engine starts, the lamp will be extinguished. It means the oil lube system pressure is normal. When the engine is idling, the light may be illuminating because it is normal that pressure in the lubrication system is low during the idling period. If the lamp is lit under normal engine rpm, it should be checked immediately after engine shut down.

Figure 2-7 Engine Oil Pressure Warning Lamp

## Operation Description

### Left Rocker Switch Assembly



1. Signal switch
2. Light switch

Figure 2-9 Left Rocker Switch Combination

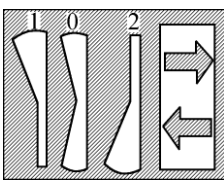

#### Signal Switch

Position 1: Left signal lamps are on.

Position 0: Power supply off.

Position 2: Right signal lamps are on.

Figure 2-10 Signal Switch

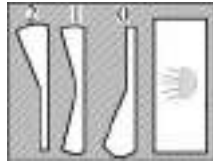

#### Work Lamp Switch

Position 2: Both position lamp and rear lights are on.

Position 1: Position lamp is on.

Position 0: Power supply off.

Figure 2-11 Work Lamp Switch

### Right Rocker Switch Combination



1. Dimmer switch ; 2. Hazard alarm switch

Figure 2-12 Right Rocker Switch Combination

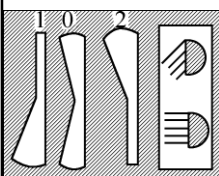

#### High/Low Dimmer Switch

Position 1: Spare.

Position 0: Low headlight on.

Position 2: High beam on.

Figure 2-13 Dimmer Switch

## Operation Description

### Hazard Warning Switch

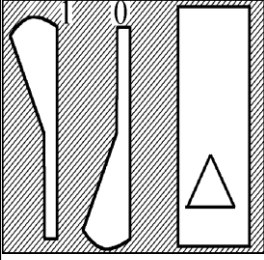

The hazard warning switch should be used in case of a tractor malfunction where the tractor is stopped in a potentially dangerous area.

Figure 2-14 Hazard Warning Switch

### Horn Switch

Horn switches are located on both arms of the steering wheel.



Figure 2-15 Horn Switch

### Ignition Switch

Put the key into the electric switch and turn it clockwise to the following positions:

- Turn the key clockwise to ACC shift, which will turn on the auxiliary electrical devices.
- Turn the key to ON shift and the control circuit will be activated.
- When the key is turned to H shift, the preheating device will be turned on.
- Once preheated, turn the key to ST shift to start the engine. After the engine is started release the key immediately, so that the key returns to the “ON” position automatically.

To avoid burning out the starter, avoid turning the key to ST shift for more than 5 seconds.

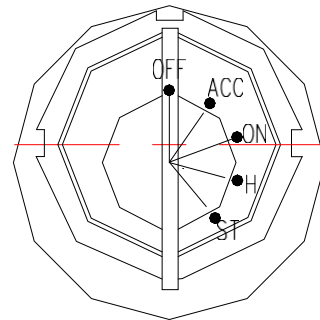

Figure 2-16 ignition lock

## Operation Description

### 2.3 Starting the Engine



**WARNING:** Before operating, the tractor should be checked over thoroughly to eliminate potential accidents or breakdowns.

#### 2.3.1 Engine Starting Preparations

- Before starting the tractor, inspect for damaged or loose parts and leakage.
- Check the engine oil pan, the gearbox, the rear axle and the lube oil level on the hydraulic system. The radiator should be filled with antifreeze and the fuel tank should be full.



Figure 2-17 throttle lever

- Check the control lever of the gearbox and the PTO control handle. The main shift lever, PTO control handle and front drive axle control handle should be in the neutral position. The distributor control lever should be in the lowering position.
- Turn the fuel shut-down knob to fuel shut-down cable. The oil-spraying pump should be in the oil-supplying position.
- The throttle handle should be set at mid range.
- Before starting a tractor that is new, recently overhauled or one that hasn't been used for a long time, first discharge the air in fuel line to ensure that the diesel engine can start smoothly. The procedure is as follows: Release the bleeder screw on the diesel filter, then discharge the air in fuel line from fuel tank to the diesel filter using a hand pump until there are no bubbles in the discharged fuel. Then, unfasten the bleeder screw on the fuel pump to release the air until there are no air bubbles in the flow of fuel.

#### **IMPORTANT NOTES:**

1. Clean contaminants from the radiator screen regularly to avoid over heating the engine.

#### 2.3.2 The Starter

#### **IMPORTANT NOTES:**

1. Release the key immediately after starting of engine. The key will return to the ON position automatically (see Figure Igniting Lock). If not released, the engine will continue to rotate the starter, causing damage.
2. The key should be turned no longer than 5 seconds and you should allow 15 seconds of time between starts. To maintain the charging ability of the battery, do not try to start the tractor more than three times and troubleshoot in order to find the problem.

## Operation Description

### 2.3.2.1 Battery Start

- Starting at ambient temperature (above 23°F): Turn the key to the ON position to start the auxiliary and the control circuit. Then turn the key to the ST position to start the engine. Release the key immediately after starting (the key will return to the ON position automatically); When you have a safety start switch, first step on main clutch pedal and then turn the key to start the engine.
- Preheating start (for models with a preheating circuit)

When starting the tractor in low temperatures (below 23°F), use the preheating starting instructions. Put the throttle handle in the acceleration position, turn the key clockwise to H position and leave it on H for 15–20 seconds. Turn the key to the ST position to start the starter. Release it immediately after starting and the key will automatically return to the ON position.

Start with a traction tractor: When starting a traction tractor, the traction tractor uses High III or High IV gearing; for safety, the speed of traction tractor should not be higher than 15km/h.

**Note:** When starting a traction tractor, once the engine is started, step on main clutch pedal immediately and throttle down.

### 2.3.3 Running the Engine

- After the engine is started, ease up on the throttle immediately to allow the engine run at idle. Check the engine oil pressure to ensure that the indicator on the oil pressure gauge is in the green zone.
- After the engine is started, do not run a full-load immediately. The engine should be run at idle to medium speed to heat the engine. When the coolant temperature rises above 140°F, you can then increase to high speed and operate at full load capacity.
- The engine rotary speed and load should be slowly increased or decreased, especially for a recently started engine; never use the throttle handle to run at high speed.
- When the tractor is running the engine oil pressure and coolant temperature shall be checked regularly. During normal operations of the engine, the indicator on the oil pressure gauge and water thermometer should be in the green zone.

**IMPORTANT NOTES:** When the engine is running, the indicator on the engine oil pressure gauge should never be in the red zone. Troubleshoot immediately.



## Operation Description

### 2.4 Starting the Tractor

- With the engine running at low speed, step on the clutch pedal. Then, put the gear box shift level in the right position.
- Release the brake pedal lock device.
- Check for obstructions and honk your horn.
- Release the clutch pedal immediately after starting to avoid the clutch slipping. Gradually accelerated, so that the tractor can reach the required operation speed.

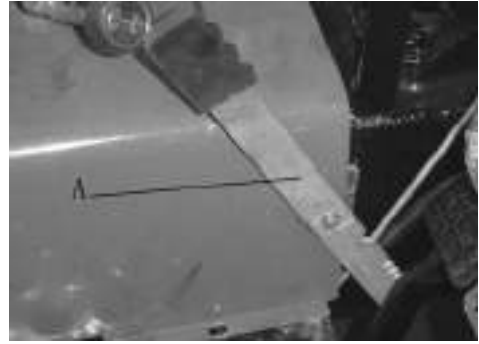

Figure 2-18 Starting the Tractor

- During use, never drive with the clutch semi-engagement in order to lower the tractor speed. Keep the clutch pedal free of obstructions in order to avoid accelerating the releasing rod and friction disc wear.

**IMPORTANT NOTES:** To prevent damage to the drive gear in the gearbox or early clutch damage, do not start in high gear.

### 2.5 Steering the Tractor

2.5.1 When driving the tractor on the road, press the turn switch to light the indicator, and finally, make the turn. Reduce the speed before making a turn. If you have to make a large turn, make the turn at a slow speed.

2.5.2 When turning the tractor tightly or on loose/soft ground, you may experience some sideslip on the front wheel. When this happens, step on the corresponding brake pedal and rotate the wheel to make the turn.



**WARNING:**

1. Never make sharp turns when the tractor is moving at a high speed. When turning the front wheel sharply, to prevent damage to the hydraulic steering system, the steering wheel may pull back slightly. This is to prevent the hydraulic steering system from being overloaded.
2. Before making turns or backing up during field work, make sure that any machinery is lifted from the soil to avoid damage.

## Operation Description

### 2.6 Shifting the Tractor

#### Shift 28+2, Shift Shuttle 8+8, Shift Creeping 16+4

- The main and auxiliary gear shift is controlled by one control handle to achieve 8+2 shifts. The main gear shift lever (A) has four gears (3 and one reverse shift-R. The auxiliary gear shift lever (B) has two speed ranges, L is low speed and H is high speed.

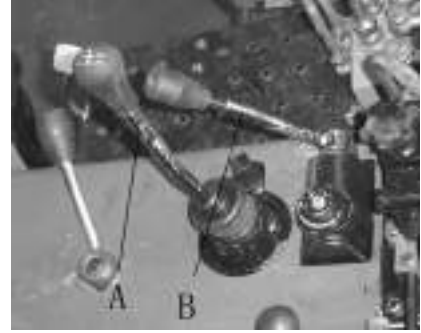

Figure 2-19 Differential Operation (20FT)

- Step on the clutch pedal and operate the auxiliary gear shift lever (B). Push down from the neutral position; low shift, L. If lifting up use the high shift, H.
- Figure 2-19 Shifting the Tractor
- Step on the clutch pedal, push forward on the main shift lever (A) from the neutral position. Shift 1: pull backward. Shift 2: move to the left from neutral and then pull backward. Shift 3: push forward. Shift 4: move to the right from neutral and then push forward. Reverse gear shift (R).
- If the shuttle shift is mounted as an option, one shuttle shift handle will be added on the left top of the instrument combined with the main/auxiliary gearshift rod (main gearshift rod cancels backward shift), 8 forward shifts and 8 backward shifts can be obtained.
- Select the operating speed to obtain optimum productivity and economy and prolongation of service life. When working in field, the selected speed of the tractor should leave the engine load at 80%. When the tractor does light-duty operations at a low speed, high shift 1 can be used to save fuel by throttling down.

### 2.7 Differential Lock Operation

#### Differential Lock Operation

If the tractor is stuck, you can engage the differential lock using the following sequence, which will connect the left and right drive axle:

- Step on the main clutch pedal and engage the low gear.
- Push the throttle control handle to increase the supply position.
- Push forward on the differential lock operation rod (A) on the right bottom of the driver's seat



Figure 2-20 Differential Lock Operation

- Release the clutch pedal smoothly to operate the tractor.
- After getting out of the obstruction, pull the differential lock lever (A) and operate in reverse to release.

**IMPORTANT NOTES:** When the tractor is running on normal surfaces, never use the differential lock. This will help you avoid damage to components and reduce tire wear.

## Operation Description

### 2.8 Front Drive Axle Use

The Foton FT series of 4-wheel drive tractors can be used for normal operations in the field and on wet and soft soil. If only rear wheel drive is used, the traction performance of the tractor may not be enough. When this is the case, the front drive axle can be used to increase the traction force and decrease the slippage. In order to engage and release the front axle, the following operation sequence should be followed:

#### Connecting the Front Drive Axle

Step on the main clutch pedal, engage the gear and then release clutch pedal slowly. After the tractor moves a little, immediately pull the front drive axle control handle backward to change the two-wheel drive into four-wheel drive.

#### Disconnecting the Front Drive Axle

When you need to disengage the front drive axle, push downwards on the front drive axle handle to disengage.

**IMPORTANT NOTES:** When using the tractor to transport on a hard-surface road, never connect the front drive axle. Connecting the front drive axle can result in early wear of the front tire and excessive fuel consumption. In conditions where traction is a concern the front drive axle should be engaged. Once the tractor is back on a stable surface, the front drive axle should be disengaged.

**NOTE:** When performing a transportation operation, the front wheel tires will wear rapidly and the left and right sides of tire tread patterns will worn unevenly. For this reason, it is a good practice to switch the left and right tires on occasion.

### 2.9 Tractor Braking

#### 2.9.1 Tractor Braking

1. Reduce throttle, step on the clutch pedal, and then gradually step on the brake to stop and park the tractor.
2. In an emergency, step on the clutch and brake pedal simultaneously. Never step on the brake without stepping on the clutch. This can cause the engine to stall.
3. When running the tractor on the road, lock both the left and right brake pedals together with a locking plate.

#### 2.9.2 Left/Right Brake Pedal Interlocking

When tractor is used on the road, lock both the left and right brake pedals together with a lock plate.



#### **WARNING:**

1. Prior to operating the tractor, make sure that the brakes are functioning properly. When the brakes are not in working order, this can result in an accident and/or serious injury.
2. When operating the tractor on the road, the left and right brake pedals should be interlocked to prevent the tractor from operating erratically or overturning when applying the brake.

## Operation Description

### 2.10 Stopping the Tractor and Engine Flameout Procedures

1. Throttle down to decrease the tractor's running speed.
2. Step on the clutch pedal, the brake pedal and lock the braking handle. When the tractor stops, put the gearshift in neutral.
3. Release the clutch/brake pedal, and reduce the throttle to make the engine run smoothly.
4. Pull the fuel shut-down cable back, which stops the fuel pump from supplying fuel.
5. Turn starting switch key to the OFF position and shut off all power supply.

### 2.11 Tire Usage and Assembly/Disassembly

#### 2.11.1 Tire Use

- The Tire is a consumable. Attention should be paid to its use and maintenance in order to prolong its service life.
- The tire has a specified loading value. If overloaded, the tire can wear excessively and possible rupture.
- Running a tire below its recommended pressure will cause the tire to wear unevenly and make the tractor difficult to operate. Pressure in the tire should be measured with a pressure gage in ambient temperature. Don't measure tire pressure immediately after operation because the tire will heat during use. Improper operation can wear or damage the tires prematurely. Avoid going over obstacle at high speed, emergency stopping or hard steering. When running over a gravel road, tire slippage should be avoided as much as possible.
- During use, the tires should be kept clean of any oil, acid, alkaline chemicals or corrosives. Keep the tires out of bright sunshine as much as possible, in order to avoid rubber aging and degrading.
- The front wheel alignment and toe-in should be checked regularly for correctness, in order to avoid tire wear. When tires wear is nonuniform, the left and right tires can be switched.

**Important notes:** The inflation pressure for the front and rear tires on a 4-wheel drive tractor should be the same in order to prevent the tires from being worn.

#### 2.11.2 Tire Removal and Refit

##### Tire Removal

Special tools are needed to assemble and disassemble a tire. Contact a qualified tire service center to replace tires.



**WARNING:** When inflating the tire, never remove the lug nuts from the hub. This could cause the tire to fall off and may result in damage to the tractor and serious personal injury.

### 2.12 Counterweight

Counterweight is added or reduced according to the requirements of tractor. When traction force has to be increased for operating in a dry field or for transport operations, counterweight should be added. When the tractor is used in a hilly area, the front counterweight should be increased appropriately to maintain traction. Rear counterweights are round iron castings with the weight being per piece is 68lbs. Two pieces can be installed, respectively making the total weight of the rear counterweight 136lbs. Each front counterweight is 20lbs. and a total of six pieces can be mounted, with the total mass of front counterweight at around 120lbs.

## Operation Description



**NOTE:** Remove the counterweights from the wheel before removing the rear wheel from the tractor to avoid injury or damage.

### 2.13 Driver's Seat Adjustment

The driver seat for series FT tractors can be adjusted in both a front and rear direction. During the course of adjusting, turn the adjustment handle (A) on the outside lower left of the driver's seat (see diagram). At the same time, move the seat forward or backward. Release the handle once the required position is achieved.

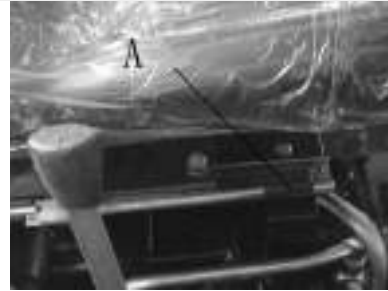

Figure 2-23 Driver's Seat Adjustment



**Note :** For safety, the seat cannot be adjusted while the tractor is in motion.

### 2.14 Hydraulic Suspension Operation

The Series FT tractor uses a semi-separate hydraulic lifting system with two types of adjustment modes: position adjustment and height adjustment. Farm machinery is lifted and lowered through the distributor control handle. When the handle is pressed forward, the farm machinery will lower; when the handle is pulled back, the farm machinery will lift. For the highest lifting position and the lowest position of farm machinery, see “hydraulic lifting system adjustment”

#### 2.14.1 Position Adjustment

When the tractor doesn't have a land wheel, the position adjustment is used. The tilling depth of farm machinery is determined by the position of the lowering stopper in the reset push rod. When using, the lower stopper should be adjusted to the preset position. When the farm machinery lowers to a suitable depth, touch the lower stopper and the shift end of the handle will be pushed back to the neutral position. The farm machinery will stop lowering and work at the set depth (the adjustment method is shown in the adjustment on the hydraulic lift system).

#### 2.14.2 Height Adjustment

When the tractor has a land wheel, height adjustment is used. The tilling depth of farm machinery is controlled by adjusting the height from the ground level to the plow bottom. When using, the lower stopper should be adjusted to the lower limit, and the handle set on the lower position. When the farm machine is lowered to the required depth (adjustment method is shown in the adjustment on the hydraulic lift system), the farm machinery will operate at the tilling depth.

**NOTE:** Adjust draft control according to implement specifications.

## Operation Description

### 2.14.3 Lowering Speed Adjustment

Select a suitable lower speed for the farm implement to keep from being damaged by heavy impact when it contacts the ground. Before delivery, the descending speed regulating valve was adjusted. The owner/operator can readjust the valve according to the weight of farm machinery and ground hardness.

- The farm machine will lower when the adjustment valve (A) is turned in a clockwise direction.
- When turning the regulating valve (A) counterclockwise, the lowering speed of the farm machinery will increase. (See figure 2-23)

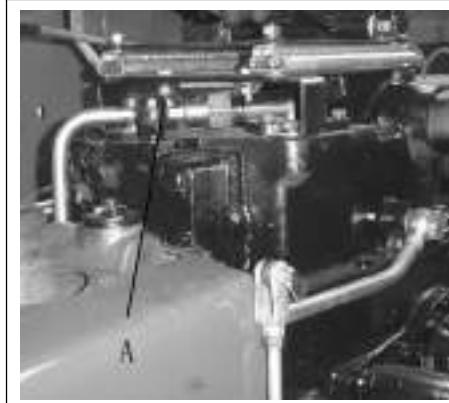

Figure 2-24 Adjustment Valve Diagram

### 2.14.4 Application of the Hydraulic Output and Lock

- Turn the adjustment valve (B) in a counterclockwise direction until the valve is closed. This will also close the adjustment valve on the inlet and outlet of the oil cylinder. The male connector on the quick change coupler is connected with the oil inlet of the farm machinery. The hydraulic output female connector (A) is connected with the male connector on the farm machinery. Push the distributor control handle to the lifting position to achieve the appropriate hydraulic output. Simple hydraulic output can only control a single-action oil tank.
- When using the hydraulic output, the farm implement should be in the lift position, if the lower speed adjustment valve (B) is closed and the oil in the tank can not return. The farm implement should be locked in the transport position and the adjustment valve can act as the hydraulic lock.



Figure 2-25 Hydraulic Output Diagram



**Note:** When traveling a long distance with farm machinery, they should be locked with the hydraulic valve to prevent the distributor control handle from being touched during the course of driving to avoid an accident.

## Operation Description

### 2.14.5 Use of multiway valve (Optional)

- Switch off the engine.
- Put the lifter in lowering position.
- Move the hydraulic output valve operation handle forward and backward, in order to eliminate the pressure in the hydraulic adapter seat.
- Take out the sealing cover of the adapter seat and clean the adapter.
- Connect the spare male connector to the female connector with the quick change coupler, and then connect the oil inlet and outlet of the double-action oil tank on the farm machine. The multi-way valve has four quick change couplers, with female connections (AB1 and AB2). The control handle (C) controls the first hydraulic output (AB1) and control handle D controls the second hydraulic output (AB2).

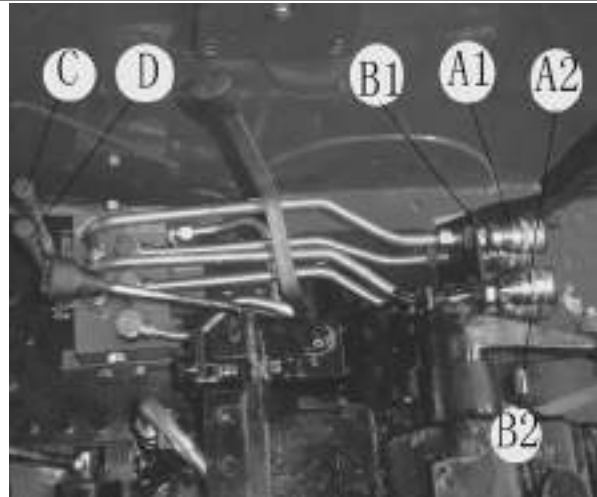

Figure 2-26 Multi-Way Valve (25FT)

### IMPORTANT NOTES:

- 1 When a hydraulic output device is used, the connector seat should be covered with a seal cover to avoid dust.
- 2 After the hydraulic output device is used, the operating handle should be set to the neutral position, otherwise, the hydraulic system may overheat.

## Operation Description

### Suspension Mechanism Application

During tilling operations, the plow is adjusted vertically and horizontally to ensure that the tilling depth is the same.

- Adjusting the horizontal in a longitudinal direction: Adjust the upper pull bar's (A) length to keep the plow frame horizontal in a longitudinal direction for an equal tilling depth of each plow. When the front blade is deep and rear blade is shallow or the plow heel is away from the bottom of trench, the upper pull rod should be extended. When the front blade is shallow and the rear blade is deep or the plow heel compacts the bottom of the trench, the upper pull rod should be shortened.
- Horizontal adjustment: Adjust the length of the right and left lifting rod to keep the plow frame level. When the right lifter rod (B) is extended, the tilling depth of the first plow will be deeper. When the rod (B) is shortened, the tilling depth of the first plow will be shallower. Usually, the left lifting bar (C) is not adjusted, except when the adjustment amount of the right lifting bar is not enough. The left rod is adjusted for a same tilling depth of each plow.



Figure 2-27 Suspension Mechanism

### Important notes

1. When plowing, never adjust the deflective traction of the farm machinery by fixing the limit rod. This will help you avoid damaging the suspension mechanism.
2. When plowing, in order to avoid the suspension mechanism damage, the tractor should never be turned without lifting the farm machinery.

**Note:** The limit rod is use to prevent the lower pull rod from hitting the rear wheel of the tractor due to excessive swinging when the tractor lifts the farm machinery and turns at the end of field. When the farm machinery is in the tilling position, the limit rod is in a loose state. A certain oscillating quantity between the tractor and farm machinery is allowed



## Operation Description

### 2.14.7.2 Power Take-Off (PTO) Shaft Use (with a dual-function clutch)

Power for the PTO shaft is switched on and off by a 2-stage clutch, the PTO disengagement control handle and the power output gear shift knob on the left rear of the gearbox. When the power output disengagement control handle is pushed downwards from the front position, the control lever pushes the engagement sleeve in the gearbox back. The PTO is engaged and disengaged with a reverse movement. Push the PTO gear shift handle forward for a high-speed shift and pull the handle backward for a low-speed shift. The procedure is as follows:

- Remove the traction frame and the power output cover, then install the required farm machinery.
- The power output gearshift handle is set in the required gear.
- Step on the clutch pedal to the lowest position to disengage the power output clutch. Then push the power output clutch disengagement control handle to the “engaged” position.
- Release the clutch pedal slowly. First throttle down to run at low speed and check if the operation is normal, and then start operating.
- When short-time repetitive activity in one place is needed, it is necessary to step on the clutch pedal lightly to disengage the main clutch. At this time, power for the tractor gearbox is disconnected, the tractor stays in place, however, the farm machinery in the rear is still working normally.
- When you need power output, the power output operation handle should be in the release position, and the cover for the power output shaft should be remounted.



**WARNING:** When transporting farm machinery over long distances, the PTO control handle should be pushed to the “disengaged” position to power off and prevent personal injury and/or the farm machinery from being damaged.

### 2.14.8 Electrical Equipment Usage

The electrical system for the series FT tractor is a 12V negative ground system. For components and circuit of electrical system, see Diagram 2-30

#### 2.14.8.1 Battery

The battery is used to store the alternator energy. When the alternator does not work or runs in low speed, the stored energy can be provided to the power-using equipment and as a secondary short-term power supply for an overload.

- Series FT tractors use a maintenance-free battery.
- You should clean the dust and oil stains on the battery cover to avoid electric leakage. Check if there are any cracks and leaking electrolyte fluid. Good contact between the poles and the conducting wire is vital. The air vent in the plastic cover should be smooth to avoid an explosion.
- Starting time shouldn't exceed 5 seconds each time to prevent battery drain.
- If the tractor is not used for a long time, the battery should be removed and maintained.

## Operation Description

---

### 2.14.8.2 Alternator

- The alternator should be used together with the regulator.
- The alternator has a negative ground. Positive and negative poles of the alternator, regulator and battery need to be connected properly. If not, the alternator and the regulator will be damaged.
- Never check if the alternator is generating power by grounding the ignition.
- After parking the tractor, remove the ignition key to cut off the connection between the motor and battery, so that the battery will not discharge.

### 2.14.8.3 Starter

- The starter cannot keep on working for long amounts of time. Each starting time should not exceed 5 seconds to avoid starter damage.
- When starting the tractor, avoid engaging the key if the tractor is already running.
- During starting, if the starter keeps on running when the key resets, you need to pull the shut-down cable immediately. Troubleshoot before starting.

### **2.15 Tractor Break-In**

Before using, the tractor should run for a certain period with proper lubrication, at a certain rpm and without a full load. After the warm up period, the tractor should be checked and adjusted. This period of time is called running-in.

#### **2.15.1 Preparations prior to break-in**

- During break-in, technical maintenance per shift and per 50 hours should be made on the tractor. See Operation Manual 4 Maintenance.
- Apply emergency brake.
- Check and tighten the bolts, nuts and screws outside the tractor.
- Fill lube grease into the grease fittings of the front wheel hub and front axle. Check the oil levels in the oil pan, drive train, hydraulics, front drive axle, central drive and final drive. If not adequate, fill them according to the specification.
- Fill the diesel fuel and coolant to specifications.
- Check the tire pressure.
- Check the electrical circuits.
- Lubricate all grease fittings.
- Put the operation handles (PTO, transmission, hydraulics) in neutral.

#### **2.15.2 Engine break-in without a load**

Perform idle running-in for 15 minutes. Start the engine according to the sequence specified in the “Diesel Engine Operation & Maintenance Instructions”, and run the engine in a sequence at low speed first, then at mid-speed and finally at high speed (5 minutes each).

During the idle break-in, check the working conditions of engine, and the hydraulic oil pump. Observe if there is abnormal operations and sounds. Check for any water, oil or fuel leakage. Check the instrumentation. When any abnormal conditions occur, stop immediately and troubleshoot. Repeat break-in procedure.

The following break-in cannot be started until the engine is working normally.

#### **2.15.3 Power take-off (PTO) shaft break-in without a load**

The engine throttle control handle is set at the medium position, and the engine runs at medium speed. Set the PTO shaft at low speed and high speed for 5 minutes respectively, then checked for any abnormalities. The PTO shaft should be in the neutral position after break-in.

#### **2.15.4 Hydraulic system break-in**

Start the engine and run it with the throttle in the middle power position. Operate the handle of distributor and lift and lower the suspension mechanism several times. Install implement (a piece of farm machinery or similar) on the suspension mechanism, run the engine on the throttle position and operate the distribution handle to make the suspension mechanism lift up and down 20 times. Check that the hydraulic suspension mechanism can be fixed at the highest position, at the required position and check for the lifting time and leakage.

With the tractor stationary, run the engine at low and high speed, and turn the steering wheel to the left and to the right smoothly 10 times in each direction. While turning the wheel, listen for any sounds and smooth operation.

## Operation Description

### **2.15.5 Tractor break-in without a load and with a load**

After completing the PTO shaft and hydraulic system has been broke-in, proceed with tractor break-in procedures according to Table 2-2-3 on the condition that everything on the tractor checks out. Break-in time is 10 hours in total.

Load break-in can be done after the idle running-in and only after everything checks out. The load and the speed of the load running-in should be from low to high. During the break-in, pay attention to:

- Check if the electrical equipment and the readings for various instruments is normal.
- Is the engine running normally or not?
- Check if the clutch engages smoothly, and disengaged completely.
- Does the tractor shift easily and with/without random shifting or popping out of gear?
- Are the brakes working correctly?
- Check to ensure that the differential lock engagement and disengagement are working correctly.
- Check to ensure that the engagement/release of the front axle is working correctly.
- When a fault occurs, stop the break-in process and troubleshoot.

### **2.15.6 Maintenance after break-in**

After break-in, you will need to drain system and replace all lubrication oils and hydraulic fluids and conduct the necessary preventative maintenance according to recommended schedule, then you can put the engine into normal operation.

The maintenance of engine after break-in in is as follows:

- After parking, drain the warm lube oil in the diesel engine oil pan, change the oil filter and engine oil air separator, and fill with fresh lube oil as required.
- Drain transmission and hydraulic system and replace fluids.
- Perform technical maintenance on diesel motor according to “Maintenance Instruction of Diesel Motor”
- Drain the cooling water and clean the cooling system of the engine with water and then replace with new coolant.
- Check the toe-in and free strokes of the clutch and brake. Adjust if necessary.
- Check and tighten all bolts, nuts and screws outside.
- Fill lubrication grease to each lubrication point of the tractor according to Maintenance Chart.

### **IMPORTANT NOTES:**

- 1 Tractor can not be put into service until the break-in is complete and any maintenance is performed. Ignoring the break-in procedure can shorten the service life of the tractor.
- 2 The owner/operator should familiarize themselves with the tractor before performing the break-in procedures.

## Operation Description

Table 2-2 Running-in time for each stage (8F+2R shift bottom unit: h)

Tractor stopper	Forward Shift								Reverse Shift	
	Low gear 1	Low gear 2	Low gear 3	Low gear 4	H-1	H-2	H-3	H-4	R-1	R-2
Idle	0.5	0.5	0.5	0.5	0.5	0.5	0.5	0.5	0.5	0.5
When loading 1 ton on a trailer, road transportation should be used.				4	4.5	5	5	2.5		
Operating on sandy soil with a plow, working depth 14cm.		5	5	5	5	4				

Table 2-3 Running-in time for each stage (8F+8R shift bottom unit: h)

Tractor stopper	Forward Shift								Reverse Shift							
	Low gear 1	Low gear 2	Low gear 3	Low gear 4	H-1	H-2	H-3	H-4	R-1	R-2	R-3	R-4	R-5	R-6	R-7	R-8
Driving without load	0.5	0.5	0.5	0.5	0.5	0.5	0.5	0.5	0.5	0.5	0.5	0.5	0.5	0.5	0.5	0.5
When loading 1 ton with a trailer, road transportation should be used.				4	4.5	5	5	2.5								
Operating on sandy soil with a plough, working depth 14cm		5	5	5	5	4										

### 2.16 Tractor Common Faults and Troubleshooting

#### 2.16.1 Chassis Faults and Troubleshooting

##### 2.16.1.1 Clutch Faults and Troubleshooting

Table 2-4 Clutch Faults and Troubleshooting

Fault	Fault Reasons	Troubleshooting
Clutch slipping	<ol style="list-style-type: none"> <li>(1) Oil stain on friction lining and pressure plate.</li> <li>(2) Friction lining worn or burnt.</li> <li>(3) Belleville spring press reduced.</li> <li>(4) Free pedal travel too small, or no free travel.</li> <li>(5) Clutch plate severely deformed.</li> </ol>	<ol style="list-style-type: none"> <li>(1) Wash with solvent, locate the cause and do troubleshooting.</li> <li>(2) Replace the friction lining.</li> <li>(3) Replace the butterfly spring.</li> <li>(4) Readjust the free travel of the pedal according to the requirements.</li> <li>(5) Replace the clutch plate.</li> </ol>
The separation of clutch is not disengaging, and there is noise when it is engaged.	<ol style="list-style-type: none"> <li>(1) Free pedal travel is too large, or the operation travel too small.</li> <li>(2) The clutch plate is warped.</li> <li>(3) Disengaging lever heads are not on the same plane.</li> </ol>	<ol style="list-style-type: none"> <li>(1) Adjust the free stroke of the pedal according to requirements.</li> <li>(2) Replace the driven disk.</li> <li>(3) Adjust according to the requirements.</li> </ol>

## Operation Description

Fault	Fault Reasons	Troubleshooting
3. Tractor shakes when starting.	<ul style="list-style-type: none"> <li>(1) Disengaging lever heads are not on the same plane.</li> <li>(2) Oil stain on the friction lining and clutch plate.</li> <li>(3) The clutch plate is severely warped.</li> <li>(4) The bolt for the flywheel and the clutch is loose.</li> </ul>	<ul style="list-style-type: none"> <li>(1) Adjust according to requirements.</li> <li>(2) Clean friction lining and clutch plate.</li> <li>(3) Replace driven disk.</li> <li>(4) Immediately stop the vehicle and troubleshoot.</li> </ul>

### 2.16.1.2 Gearbox fault and troubleshooting

Table 2-5 Gearbox Faults and Troubleshooting

Fault	Fault Reasons	Troubleshooting
1 Putting the tractor in to gear is difficult or impossible.	<ul style="list-style-type: none"> <li>(1) Clutch is not disengaged completely.</li> <li>(2) Gearbox interlocking pull rod is too long.</li> <li>(3) Shift lever fork is severely worn.</li> <li>(4) The meshing bush end surface and gear end surface is worn or broken.</li> </ul>	<ul style="list-style-type: none"> <li>(1) Troubleshoot according to the clutch type.</li> <li>(2) Shorten the gearbox interlocking pull rod.</li> <li>(3) Replace the shift lever.</li> <li>(4) Replace or repair.</li> </ul>
2 Shift disengages automatically.	<ul style="list-style-type: none"> <li>(1) The gearbox interlocking pull rod is too short.</li> <li>(2) Locating slot of the shift fork severely worn.</li> <li>(3) The pressure of interlocking pin spring is inadequate.</li> <li>(4) The bearing on the gear shaft is worn.</li> <li>(5) Spline of tooth seat worn.</li> </ul>	<ul style="list-style-type: none"> <li>(1) Lengthen the gearbox interlocking pull rod.</li> <li>(2) Replace the shift fork.</li> <li>(3) Adjust or replace the interlocking pin spring.</li> <li>(4) Replace the bearing.</li> <li>(5) Replace the tooth holder.</li> </ul>
3 Random shift.	<ul style="list-style-type: none"> <li>(1) Shift lever fork is worn.</li> <li>(2) Gearbox guide plate is severely worn.</li> <li>(3) The fork slot of the fork and meshing bush is worn.</li> <li>(4) Locating pin of interlocking pin and shift fork is severely worn.</li> </ul>	<ul style="list-style-type: none"> <li>(1) Repair or replace the shift lever.</li> <li>(2) Replace the gearbox guide plate.</li> <li>(3) Replace the fork and meshing bush.</li> <li>(4) Replace the interlocking pin and shift fork shaft.</li> </ul>
5. Noise or knocking sound in the gearbox.	<ul style="list-style-type: none"> <li>(1) The gear wear is severe, the tooth surface is peeled or the wheel tooth is broken.</li> <li>(2) Bearing is worn or damaged.</li> <li>(3) Lube oil is not efficient, or the quality is not in compliance with the requirements.</li> </ul>	<ul style="list-style-type: none"> <li>(1) Replace gear.</li> <li>(2) Replace bearing.</li> <li>(3) Fill or replace lube oil.</li> </ul>

### 2.16.1.3 Rear Axle and Brake Faults and Troubleshooting

2 Rear Axle and Brake Faults and Troubleshooting

Fault	Fault reasons	Troubleshooting
1. An increase in noise in the central drive.	<ul style="list-style-type: none"> <li>(1) The bearing play of the small conical gear is too large.</li> <li>(2) Gear engagement is abnormal.</li> <li>(3) Bearing of conical gear pair or the actual gear is damaged.</li> <li>(4) Differential gear shaft is worn or stuck.</li> <li>(5) Planetary gear or gasket is worn.</li> <li>(6) Differential gear broken or damaged.</li> </ul>	<ul style="list-style-type: none"> <li>(1) Adjust according to requirements.</li> <li>(2) Readjust according to requirements.</li> <li>(3) Replace bearing or gear.</li> <li>(4) Replace the differential gear shaft.</li> <li>(5) Replace the planetary gear or shims.</li> <li>(6) Replace the differential bearing.</li> </ul>

## Operation Description

Fault	Fault reasons	Troubleshooting
2. Small conical gear and differential bearing is hot.	(1) The pre-tightening force is too much. (2) Lubrication is poor. (3) The backlash at gear pair side of conical gear is too small.	(1) Readjust the bearing pre-tightening force. (2) Check the oil level, add if necessary. (3) Readjust the backlash.
3. Abnormal noises from the final drive.	(1) Bearing, gear or shaft damage.	(2) Replace bearing, gear or shaft.
4. No braking control.	(1) Free stroke of the brake pedal is too large. (2) Friction lining is worn severely or unevenly. (3) The free stroke of the pedal is too large.	(1) Readjust the free stroke of the pedal. (2) Replace the friction lining. (3) Adjust the free stroke of pedal according to requirements.
5 Brakes gets hot.	(1) Brake friction disk does not return. (2) Friction plate and brake hub don't disengage completely.	(1) Replace the return spring. (2) Adjust according to the requirements.
6. The tractor pulls in one direction when braking.	(1) The travel of the left and right brake pedals are not consistent. (2) Brake friction lining on one side is damaged. (3) Pressure in two rear tires is uneven.	(1) Adjust. (2) Replace friction lining. (3) Check and fill tires with air according to requirement.

### 2.16.14 Four-Wheel Drive System Faults and Troubleshooting

#### 2-7 Four –Wheel Drive System Faults and Troubleshooting

Sequence No.	Fault	Fault Reasons	Troubleshooting
1.	Front wheel tire has excessive wear.	(1) Front wheel rim or the spoke is severely deformed. (2) Toe-in of the front wheel is abnormal. (3) Steering knuckle and two pin shafts of the oil tank are worn. (4) Tire pressure is not adequate. (5) Front axle does not release before transportation. (6) Drive tire thread mounted backwards.	(1) Calibrate front wheel rim or spoke. (2) Adjust the toe-in. (3) Replace axis pin. (4) Fill tire with air according to requirement. (5) Disconnect the front drive axle. (6) Refit the wheel according to the requirements.
2	Front wheel shakes.	(1) Set nuts or bolts for the ball pin, oil cylinder and the steering arm are loose. (2) Toe-in of the front wheel is abnormal. (3) Bearing gap too large or severely worn. (4) Knuckle pin is severely worn. (5) Front wheel rim is deformed.	(1) Check and tighten. (2) Adjust the toe-in. (3) Adjust or replace the bearing. (4) Replace the knuckle pin. (5) Replace the front wheel rim.
3	Loud noise (four-wheel drive tractors).	(1) Engagement trace of the front central drive gear is abnormal. (2) Clearance between the central drive bearing is too large or destroyed. (3) Differential axle is worn or damaged. (4) Planetary gear or gasket is worn. (5) Final meshing of planetary gear pair is faulty.	(1) Readjust the meshing lash. (2) Adjust or replace. (3) Replace the differential gear shaft. (4) Replace the planetary gear or shims. (5) Replace the planetary drive gear.

## Operation Description

4	Drive shaft and sleeve become hot (4-wheel drive tractor).	(1) The drive shaft is severely bent or deformed creating friction.	(1) Replace the drive shaft
5	Auxiliary box noise (4-wheel drive tractor).	(2) Speed gear is too high. (3) Bearing or gear is severely worn.	(2) Put into low gear. (3) Replace

### 2.16.15 Hydraulic Steering System Faults and Troubleshooting

Table 2-8 Hydraulic System Faults and Troubleshooting

Sequence No.	Fault	Fault Reasons	Troubleshooting
1	Oil leakage.	(1) Rubber o-rings or bolts at various pipe joints are damaged or loose. (2) Hydraulic steering gear valve body, stator and rear cover rubber o-rings are damaged. (3) Rubber o-ring at the axle journal is damaged. (4) Leaks in hub subassembly	(1) Replace the rubber ring or tighten the bolt. (2) Replace the rubber ring. (3) Replace the rubber o-rings. (4) Tighten the bolts.
2	Heavy steering.	(1) Not enough oil delivery to the gear oil pump. The gear oil pump leaks inside or the oil screen inside the steering oil tank is blocked (light at low speed and heavy at high speed). (2) Erratic steering cylinder movement when the steering wheel is rotated. (3) The oil level in the steering oil cylinder is insufficient. (4) Spring tension in the relief valve becomes weak, or the steel ball is not sealed, light load is steering lightly, and steering becomes heavier if load is increased. (5) Oil viscosity is too high. (6) Steel ball check valve in the valve body fails; the steering wheel is heavy when turning it slowly or weak when turning sharply. (7) Oil leakage from steering system, both inside and outside.	(1) Check the gear oil pump. Clean the filter screen. (2) Discharge the air in the system and check if air exists in the oil suction pipe. (3) Fill oil to specified height, clean the relief valve and adjust the spring pressure in the valve. (4) Replace parts and components. (5) Drain oil and replace with specified oil (6) Replace valve. (7) Troubleshoot the point of the oil leakage and repair or replce.
3	Steering column failure.	(1) Linkage shaft opening is broken or deformed. (2) Rotor and linkage shafts are improperly mounted. (3) Steering oil cylinder piston or piston seal ring is damaged.	(1) Replace the coupled axle. (2) Refit. (3) Replace
4.	Hydraulic steering without power.	(1) Clearance between the rotor and stator is too big on pump. (2) Driver does not feel endpoint strongly when steering with the oil cylinder piston in the extreme position; when manual steering, the steering wheel rotates and oil cylinder does not move.	(1) Replace pump. (2) Replace
5.	Steering is hard to turn.	(1) The gap between valve inside and the valve sleeve is too large. (2) The gap between interlocking shaft and fork pin is too large. (3) The gap between the interlocking shaft and the rotor is too large. (4) The return spring plate is broken or too soft.	(1) Replace. (2) Replace. (3) Replace. (4) Replace.



## Operation Description

### 2.16.16 Hydraulic Suspension System Faults and Troubleshooting

Table 2-9 Hydraulic Suspension System Faults and Troubleshooting

Sequence No.	Fault	Fault Reasons	Troubleshooting
1	Cannot lift the load.	(1) Oil level inside the lifter is low. (2) The strainer of the oil filter is blocked. (3) Air getting in the suction pipe. (4) Gear oil pump failure. (5) The spring pin on the outside/inside end of the operation handle dropped. (6) The swing rod inside the distributor dropped. (7) The main control valve seized at the middle or lowering position, or the oil return valve seized in the open position. (8) Main control valve seized. (9) Lowering valve seized. (10) Pin shortened, or lowering valve assembly loose, making it unable to open the lowering valve. (11) Oilway from the cylinder end to the oil cylinder is closed.	(1) Add oil to the specified oil level (2) Clean or replace the strainer of oil filter (3) Check for leaks (4) Replace gear oil pump (5) Refit spring pin (6) Open distributor, and fit swing rod (7) Dismantle distributor, and clean valves (8) Clean main control valve (9) Clean lowering valve (10) Remove plug for lowering valve, readjust the gap of lowering valve push pin or tighten lowering valve assembly (11) Open the oil way
2	Lift should be in light load or is slow in heavy load.	(1) The oil suction line sucks air or air enters the line. (2) The adjustment pressure for the system safety valve is too low. (3) The adjustment pressure for oil cylinder safety valve is too low. (4) Gear oil pump is worn or pressure is inadequate. (5) Oil cylinder seal ring is leaking.	(1) Check the oil suction line and oil filter. (2) Replace the system safety valve. (3) Replace oil cylinder safety valve. (4) Replace the gear oil pump. (5) Replace the oil cylinder seal ring.
3	Farm machine shakes or lifts slowly.	(1) Oil filter blocked. (2) Air getting into the suction pipe. (3) Gear oil pump failure. (4) Hydraulic oil level is too low.	(1) Replace the filter element. (2) Replace the O-seal ring. (3) Replace the gear oil pump. (4) Add lube oil according to the requirements.
4	Implement slowly drops after being lifted and after turning off the engine.	(1) The tightness of the check valve of the distributor is poor. (2) The lowering valve is loose. (3) The oil cylinder safety valve is leaking or improperly adjusted. (4) O-ring for the oil cylinder is damaged or leaking. (5) The seal ring between the distributor or the cylinder end and the lifter case is improperly installed, peeled or damaged.	(1) Clean the check valve. (2) Clean the lowering valve. (3) Readjust the oil cylinder safety valve. (4) Replace the O-ring. (5) Replace the seal ring.
5	When the handle is in	(1) Because of improper adjustment, the inner lifting arm props against	(1) First measure the lifting height of implement, then readjust. Shorten

## Operation Description

Sequence No.	Fault	Fault Reasons	Troubleshooting
	lift position the distributor emits a loud noise.	the lifter case to open the safety valve.	the force/position adjusting rod to make the lift height lower than the original position.
6	Hydraulic lifter has no hydraulic output or weak output.	<ol style="list-style-type: none"> <li>(1) The oil inlet pipe of the oil cylinder is cut off.</li> <li>(2) Front cone and conical hole of speed lowering control valve have not been sealed tightly.</li> <li>(3) Lifter is in the neutral lifting position.</li> </ol>	<ol style="list-style-type: none"> <li>(1) Fasten the control handle to lower the speed.</li> <li>(2) Replace the valve.</li> <li>(3) Push the lifter control handle to the lowering position to lower the outer lifting arm to the lowest position. Shut off the inlet oil line to the oil tank, then put the operation handle in the lift position.</li> </ol>

### 2.16.2 Electrical System Fault and Troubleshooting

#### 2.16.2.1 Starter Faults and Troubleshooting

Table 2-11 Starter Faults and Troubleshooting

Sequence No.	Fault	Fault Reasons	Troubleshooting
1.	The starter doesn't work.	<ol style="list-style-type: none"> <li>(1) Battery capacity is insufficient.</li> <li>(2) Battery pole is dirty or the cable is loose.</li> <li>(3) Cable connector is loose.</li> <li>(4) The wires in control circuits such as the start switch are broken.</li> <li>(5) No contact between the carbon brush.</li> <li>(6) Circuit broken or a short in the starter.</li> </ol>	<ol style="list-style-type: none"> <li>(1) Charge the battery according to the specifications.</li> <li>(2) Remove dirt and tighten the connecting parts.</li> <li>(3) Tighten connectors.</li> <li>(4) Check circuit and connection.</li> <li>(5) Replace starter.</li> <li>(6) Replace starter.</li> </ol>
2	Starter failure.	<ol style="list-style-type: none"> <li>(1) Battery capacity is insufficient.</li> <li>(2) Poor wire connections.</li> <li>(3) Rectifier surface burnt or contaminated by oil.</li> <li>(4) The carbon brush is worn or the spring pressure is insufficient.</li> <li>(5) Bad contact with rectifier.</li> <li>(6) Main contact of the solenoid switch is burned, resulting in a poor connection.</li> <li>(7) Bearing severely worn. Armature rubs against the case.</li> </ol>	<ol style="list-style-type: none"> <li>(1) Charge the battery.</li> <li>(2) Tighten the wire connections.</li> <li>(3) Replace commutator or remove the oil stains.</li> <li>(4) Replace</li> <li>(5) Replace.</li> <li>(6) Replace.</li> <li>(7) Replace</li> </ol>
3	After the engine has been started, it continues to run, but emits a sharp noise.	<ol style="list-style-type: none"> <li>(1) Circuit breaker copper contact disc and the two contacts on the starter are stuck.</li> <li>(2) Starter lever disengaged or loose bolts.</li> <li>(3) Lever return spring is broken or loose.</li> <li>(4) Starter motor armature shaft is broken or bent.</li> <li>(5) Tooth surface snapped or locked.</li> <li>(6) Contact(s) of the starting relay are stuck.</li> <li>(7) Igniting switch doesn't return automatically after starting.</li> </ol>	<ol style="list-style-type: none"> <li>(1) Replaces tarter</li> <li>(2) Readjust or replace.</li> <li>(3) Replace starter</li> <li>(4) Replace starter</li> <li>(5) Replace starter</li> <li>(6) Replace starting relay.</li> <li>(7) Replace igniting switch.</li> </ol>

## Operation Description

### 2.16.2.2 Alternator Faults and Troubleshooting

Table 2-12 Motor Faults and Troubleshooting

Sequence No.	Fault	Fault Reasons	Troubleshooting
1	The alternator doesn't work.	<ol style="list-style-type: none"> <li>(1) Wiring is wrong, broken or not making good contact.</li> <li>(2) Rotor circuit broken.</li> <li>(3) Rectified diode damaged.</li> <li>(4) Carbon brush is not making proper contact.</li> <li>(5) Regulator is damaged.</li> </ol>	<ol style="list-style-type: none"> <li>(1) Check &amp; repair the circuits.</li> <li>(2) Replace alternator.</li> <li>(3) Replace alternator.</li> <li>(4) Replace alternator.</li> <li>(5) Replace alternator.</li> </ol>
2	The alternator is not charging properly.	<ol style="list-style-type: none"> <li>(1) The drive V-belt is loose.</li> <li>(2) Bad contact with the carbon brush and the slide ring contaminated by oil.</li> <li>(3) The regulator is damaged.</li> <li>(4) Not enough electrolytes in the battery or it is sulfurized or too old.</li> </ol>	<ol style="list-style-type: none"> <li>(1) Adjust the tension of the drive V-belt</li> <li>(2) Replace alternator.</li> <li>(3) Replace alternator.</li> <li>(4) Replace battery.</li> </ol>
3	The alternator is overcharged.	<ol style="list-style-type: none"> <li>(1) Regulating voltage for the regulator is too high.</li> </ol>	<ol style="list-style-type: none"> <li>(1) Replace the voltage regulator.</li> </ol>

### 2.16.2.3 Battery Faults and Troubleshooting

Table 2-13 Battery Faults and Troubleshooting

Sequence No.	Fault	Fault Reasons	Troubleshooting
1	Battery capacity is low and the engine is difficult to start.	<ol style="list-style-type: none"> <li>(1) The electrolyte level is too low.</li> <li>(2) Short circuit between electrode plates.</li> <li>(3) Sulphurization of the electrode plate.</li> <li>(4) Poor circuit connector contact, or oxide on pole is too much.</li> </ol>	<ol style="list-style-type: none"> <li>(1) Replace battery.</li> <li>(2) Replace battery.</li> <li>(3) Replace battery.</li> <li>(4) Connect, fasten, deoxidize and coat a layer of Vaseline on the pole head.</li> </ol>
2	Excessive battery discharging.	<ol style="list-style-type: none"> <li>(1) Impurities in the electrolytes.</li> <li>(2) Short circuit in the exterior wiring of the battery.</li> <li>(3) Electrolyte overflows from battery surface, short circuit positive/negative poles.</li> <li>(4) Short circuit is caused by placement of metal tool or bar between positive/negative poles.</li> <li>(5) Active substance on pole breaks off. The pole short circuit caused by deposits or by isolation plate damaged; positive/negative pole is short circuited by pole wrap.</li> </ol>	<ol style="list-style-type: none"> <li>(1) Replace battery.</li> <li>(2) Troubleshoot and repair.</li> <li>(3) Replace battery.</li> <li>(4) Replace battery.</li> <li>(5) Replace battery.</li> </ol>

## Operation Description

---

### 2.16.24 Instrument Faults and Troubleshooting

Table 2-14 Instrument Faults and Troubleshooting

Sequence No.	Fault	Fault Reasons	Troubleshooting
1	The water temperature gauge always indicates a low temperature.	(1) Circuit opened and contact at plug-in is poor. (2) Water temperature sensor damage. (3) Water temperature meter ineffective.	(1) Check & repair the circuits. Remove dirt at plug-in. (2) Replace water temperature sensor. (3) Replace water temperature meter.
2	The water temperature gauge always indicates a high temperature.	(1) Water temperature sensor short circuit or damage. (2) Short circuit. (3) Water temperature meter ineffective.	(4) Replace water temperature sensor. (5) Check and repair or remove shorted circuit faults. (6) Replace water temperature meter.
3	Oil gauge indication abnormal.	(1) Circuit opened or shorted (2) Oil volume sensor circuit broken, short or not in good contact (3) Oil pressure meter ineffective.	(1) Check and repair, then troubleshoot. (2) Repair or replace sensor. (3) Replace oil pressure meter.

### 2.16.25 Light Faults and Troubleshooting

Table 2-15 Light Faults and Troubleshooting

Sequence No.	Fault	Fault Reasons	Troubleshooting
1	Head lamp has no high beam or dimmed light.	(1) Circuit broken, short circuit fuse (2) Bad contact or damage to the (3) Filament broken.	(1) Check and repair, then connect. (2) Check and repair. Replace if necessary. (3) Replace bulb.
2	Rear light not lit.	(1) Circuit open. (2) Poor contact or damage to the rear light switch.	(1) Check and repair, then connect. (2) Check and repair. Replace if necessary.

## Operation Description

### 3. Accessories, Spare Parts and Consumables

#### 3.1 Accessories

##### 3.1.1 Safety Frame (optional)

The FT series tractor can be equipped with an OSHA safety frame to prevent the driver from being hurt by an accidental turnover.

##### 3.1.2 Swing Traction Rod (optional)

The swing traction rod is used for traction type farm machinery. The traction rod rear end connects with the farm machinery by a traction pin. The traction rod can swing right or left, making it more convenient for mounting farm machinery. When the tractor is towing farm machinery backward, however, the positioning pin (1) must be inserted into the hole of the traction plate, in order to stabilize the traction rod (2) (Figure 3-1).

The traction point can be changed to a suitable height by turning the traction rod, in order to connect the matched farm machinery .

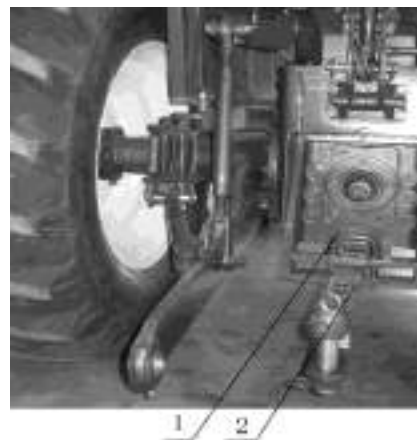

Figure 3-1 Swing Traction Application

1. Positioning Pin 2. Traction Rod

#### 3.2 List of consumables (not included with tractor purchase)

Consumables for the Foton FT series wheeled tractor include: all bearings listed in appendix 10-2, all oil seals and sealing rings listed in appendix 10-3, all fuses listed in table 3-2, and the components listed in following table:

Table 3-4 List of consumables, such as bulbs and glass products, etc

Sequence No.	Code	Description	Quantity	Remark
1	12V-1141-28W	Rear lamp bulb	1	2 pieces applied to 3rd generation model
2	12V-1141-21W	Front/rear steering lamp bulbs	4	
3	12V-89-5W	Positioning lamp bulb	2	
4	12V-H4-55/60W	Double-filament bulb for high beam and dipped headlight	1	
5	12V-1141-21W	Braking lamp bulb	2	
6	TE324.20A-01	O-ring for wire-roller	1	
7	FT220.40.301	Steering rod seal boot	1	
8	TE250.362D-01	Dust ring	1	Used for the type with shuttle shifter
9	FT250.47C.230	Machine cover seal	1	
10	TE250.475B-01	Rubber sealing strip	1	
11	YFKM385T10500	Fuel Filter Element	1	
12	YFKM385T09300	Oil filter Element	1	

## 4. Maintenance Instruction

### 4.1 Technical Maintenance Regulation

Carrying out the technical maintenance specifications of the tractor is the effective way to prolong the service life of the tractor and reduce accidents.

The technical maintenance schedule for FT series tractors is based on the accumulated work hours, which includes maintenance for: every shift, every 10 work hours, every 50 work hours, every 250 work hours, every 500 work hours, every 1000 work hours, every 1600 work hours, winter and long-term storage.

#### **Important notes:**

1. All maintenance work should be carried out by the owner/operator or a trained service professional, who is familiar with the tractor.
2. In order to keep the tractor Running-In a normal operation and prolong its service life, the technical maintenance regulations should be strictly observed.
3. The tractor warranty can be voided at any time should damage happen as the result of any operator who is unfamiliar with the tractor or when specified maintenance procedures are not performed according to manufacturer specified timelines.
4. Opening the engine and hydraulic system safety valve, the relief valve, and the voltage regulator are prohibited, without prior manufacturer authorization. Making adjustments to these sensitive areas may cause damage to the tractor, and invalidate the warranty.

#### **4.1.1 Maintenance for every shift**

- (1) Remove the dust, oil and dirt on the tractor, and clean air separator under dusty working conditions.
- (2) Check the tightness of each fastener outside of the tractor and tight them if necessary, especially the front/rear wheel nut.
- (3) Check the oil level of the engine oil pan, radiator, fuel tank, hydraulic steering oil tank, and hydraulic lifter; when checking the oil level of engine oil pan, the tractor should be parked for at least 30 minutes on a level plane.
- (4) Grease according to table 1 technical maintenance.
- (5) Check if the engine has any air/oil/water leakage. If any, eliminate the leakage.
- (6) Check front/rear tire pressure, and adjust as required.
- (7) Check and adjust the free travel of the clutch and the driving brake pedal.
- (8) Maintain the diesel engine according to the requirement of daily- maintenance described in the engine manual.

## Maintenance Instruction

### 4.1.2 Maintenance for every 50 hours

- (1) Perform all of the technical maintenance after every working shift.
- (2) Check the tightness of the fan belt (press down the belt with your hand and measure the sag (15–20mm), and make adjustments if necessary.
- (3) Spread the grease lubricant on the electrode contact of the storage battery to prevent corrosion.
- (4) Maintain the diesel engine according to the requirement of level 1 technical maintenance described in the engine manual.

### 4.1.3 Maintenance for every 200 hours

- (1) Perform all technical maintenance required for every 50 work hours.
- (2) Fill lubricating grease according to Maintenance Table 4-1.
- (3) Replace lube oil in the diesel engine oil pan and clean the oil pan and filter screen.
- (4) Replace the engine oil filter element and replace engine oil.
- (5) Replace the air filter element.
- (6) Maintain the diesel engine according to the requirements of level 2 technical maintenance specified in the engine manual.

### 4.1.4 Maintenance for every 400 hours

- (1) Perform all technical maintenance after 1-hour running.
- (2) Check the oil level of the transmission case and add if necessary.
- (3) Check the oil level of the front drive axle and add if necessary.
- (4) Check and adjust the tightness of the toe-in on the front wheel and the front wheel bearing and conduct adjustment as necessary. Replace the lubricating oil in the front wheel hub.
- (5) Check the free running angle of the front tires and conduct adjustment if necessary.
- (6) Clean and maintain the hydraulic system filter.
- (7) Maintain the diesel according to the requirement of level 3 technical maintenance described in the engine manual.

### 4.1.5 Maintenance for every 800 hours

- (1) Perform all technical maintenance after 1-hour running.
- (2) Change the hydraulic system oil.
- (3) Flush cooling system and radiator. Replace fluids.
- (4) Clean the transmission case and change the lubrication oil when the tractor is warm.
- (5) Clean the oil suction filter screen of the hydraulic system, check the cleanliness of the oil, rinse the internal cavity of the lift housing with solvent and drain, if necessary, and change the engine oil.
- (6) Check and adjust the valve clearance of the engine.

## Maintenance Instruction

---

- (7) Rinse the fuel tank and the filter in the fuel tank with solvent.
- (8) Maintain the diesel engine according to the requirement of level 4 technical maintenance described in the engine manual,

### **4.1.6 Maintenance for every 1600 hours**

- (1) Perform all technical maintenance after 1-hour running.
- (2) Check engine to manufactures specifications.
- (3) Change the lube oil in the front drive axle central drive and the final drive.
- (4) Check for bearing noise in clutch and front-end.
- (5) Check if the gap of the central drive gears and the contact footprint are normal; check the gap of the bearings and the pre-tightening. Adjust if necessary.
- (6) After maintenance, assembly and a short running-in time, check and adjust each mechanism.

### **4.1.7 Special maintenance in winter**

When the air temperature is below freezing, along with completing “the technical maintenance per shift”, the following regulations shall be strictly abided by:

- (1) Replace the lube oil and the fuel used for winter.
- (2) Check strength of coolant, if necessary add anti-freeze to the coolant system as required.
- (3) Before every shift, the engine should be started according to winter requirements.
- ( 4 ) It is recommended when the tractor is not in operation to park it in a shed that is warm and protected from the elements.

### **4.1.8 Maintenance of the long-term stored tractors**

If the tractor has been stored for less than one month, and the time does not exceed 100 hours since the engine oil was replaced, special technical maintenance is not required. If the tractor has been stored for more than one month, special technical maintenance should be performed according to Section 5- Storage specified in this manual.



## Maintenance Instruction

Table 4-1 Maintenance Table of FT Series Tractors

No.	Maintenance Part	Operation Content	Number of Points	Maintenance Period
1	Engine oil pan	Check the oil level	1	Per shift
2	Oil filter	Check the oil filter	1	Per shift
3	Hydraulic pump	Check the oil level	1	Per shift
4	Battery	Check the connectors	1	Per shift
5	Radiator	Check the coolant level	1	Per shift
6	Injection pump	Check the oil level	1	Per shift
7	Rear wheel hub	Inject the grease lubricant (2 pumps only)	1	Per shift
8	Clutch	Adjust the free travel	1	Per shift
9	Brake	Check function	2	Per shift
10	Fan belt	Check the tightness	1	Per 50 hours
11	Steering cylinder	Inject the grease lubricant	1	Per 50 hours
12	King pin	Inject the grease lubricant	2	Per 50 hours
13	Four-wheel drive front axle pendulum shaft	Inject the grease lubricant	2	Per 50 hours
14	Front wheel central balance pin bushing	Inject the grease lubricant	1	Per 50 hours
15	Fuel filter	Replace the filter element	1	Per 200 hours
	Engine oil filter	Replace the filter	1	Per 200 hours
17	Hydraulic oil filter	Clean or replace the filter	1	Per 200 hours
18	Injection pump	Change the lubricating oil	1	Per 200 hours
19	Engine oil pan	Replace the lubricating oil	1	Per 200 hours
20	Transmission case and raiser	Check the oil level height	2	Per 200 hours
21	Front wheel	Inject the grease lubricant	2	Per 400 hours
	Clutch pedal hub	Inject the grease lubricant	1	Per 400 hours
23	Brake pedal hub	Inject the grease lubricant	2	Per 400 hours
24	Front drive axle	Check the oil level height	1	Per 400 hours
25	King pin	Fill up the grease lubricant	2	Per 400 hours
26	Fuel tank	Cleaning and maintenance	1	Per 800 hours
27	Inlet valve and exhaust valve of the engine	Adjust the valve clearance	4	Per 800 hours
28	Transmission case and hydraulics	Replace the lubricating oil	2	Per 800 hours
29	Cooling system of the engine	Cleaning and maintenance	1	Per 1600 hours
30	Engine cooling system adopting anti-freeze fluid	Change the anti-freeze fluid	1	Per 1600 hours

## Maintenance Instruction

No.	Maintenance Part	Operation Content	Number of Points	Maintenance Period
31	Front drive axle central drive	Replace the lubricating oil	1	Per 1600 hours
32	Front drive axle final drive	Replace the lubricating oil	1	Per 1600 hours

## 4.2 Clutch Pedal Adjustment

### 4.2.1 Clutch Adjustment

The adjustment method of the clutch pedal working stroke is as follows:

Loosen the nut (1) (as shown in Figure 4.2, unmarked dimension unit: mm), turn the stop screw (2) to make the working stroke below the clutch rocker arm (3) 23-26mm and then lock the nut (1).

1. Lock nut
2. Stop screw
3. Release rocker arm
4. Pull rod front fork
5. Screw nut
6. Clutch pedal
7. Locknut
8. Interlock pull rod

Figure 4-2 Schematic drawing of the operating system of the clutch

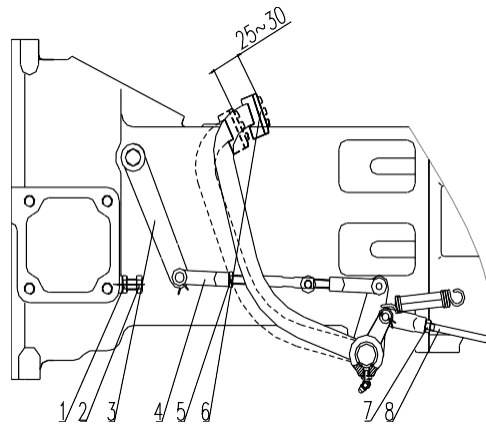

## Maintenance Instruction

### 4.2.2 Adjustment of the clutch (double action)

In order to ensure the normal operation of the clutch, the clearance between the master clutch disengaging lever 4's working surface and the release bearing 5's end face must be kept within 2 to 2.5mm; that between the end faces of the slave clutch disengaging lever in 25-to-28 horse power model and the release bearing 5 must be kept within  $B=(10\sim10.5)\text{mm}$  ( $B= (10.5\sim11)$  mm for 30-to-32 horse power model). Since the clutch friction plate constantly abrades during its operation, the aforementioned clearance will gradually diminish and even disappear. therefore, a regular inspection and adjustment must be applied.

(1) The adjustment method of the clutch pedal free stroke is as follows:

First loosen the locknut (3) on the adjusting nut (2) (as seen in Figure 4-3), then turn the adjusting nut (2) for the adjustment, making the distance between the working face of the three main clutch release lever (4) and the working face of the clutch pressure plate (1)  $A=86.5+0.2\text{mm}$  for 25-28hp models;  $A=101.5+0.2\text{mm}$  for 30-32hp models; and finally lock the locknut (3). Loosen the nut (7 and 8), turn the adjusting nut (8) to make the distance between the working face of the auxiliary clutch release lever (6) and the working face of the clutch pressure plate (1)  $C=78.5+0.2\text{mm}$  for 25-28hp models;  $C=93+0.2\text{mm}$  for 30-32hp models; and screw down the nut (8). Adjust the clutch push rod control fork 4 (as seen in Figure 4-2) to guarantee the free stroke of the clutch pedal is (25-30)mm and lock the screw nut (5) after the adjustment (see Figure 4-2).

(2) The adjustment method of the clutch pedal working storke is as follows:

Loosen the screw nut (1) (as shown in Figure 4-2), turn the stop screw (2) to make the working stroke below the clutch rocker arm (3) 35–37mm and then lock the screw nut (1).

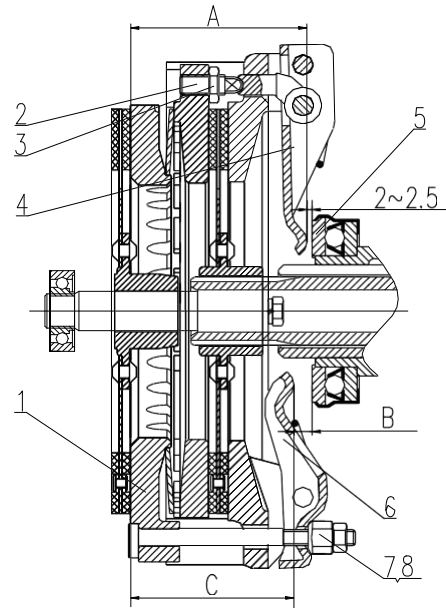

Figure 4-3 Double-action clutch

1. Clutch pressure plate
2. Set screw
3. Lock nut
4. Main clutch release lever
5. Release bearing
6. Auxiliary clutch release lever
- 7/8. Nut

## Maintenance Instruction

### IMPORTANT NOTES:

1. Adjusting the clutch requires technical skills and specific tools. If uncomfortable completing this task call Foton Technical Support.
2. In order to keep the friction plate from the oil, keep drain hole clear of any blockage below the flywheel casing. If serious leakage is found, repair immediately. Use solvent to clean the friction plate if necessary.
3. In order to avoid friction plate abrasion, the clutch should be maintained and adjusted frequently; don't release and engage the clutch randomly; when releasing the clutch, step on the clutch pedal rapidly to set the limit. Never run the tractor when the clutch is semi-engaged as this will damage the clutch.
4. Never use the tractor when the clutch is not adjusted properly. This will speed up abrasion of the clutch friction plate and possibly burn the friction plate.
5. When installing the clutch, fill with lithium base grease in the internal cavity of the release bearing support
- (6). When dismantling the clutch, replace the release bearing (5) (Figure 4-3). Replace through-out bearing.

### 4.3 Brake Adjustment

#### 4.3.1 If one the following should occur, the brake should be adjusted:

- The free stroke of the brake pedal is too large, which can cause a braking failure.
- The free stroke of the brake pedal is too small, which can cause too little clearance between the friction plate and the brake hub and semi-braking state.
- Inconsistent braking force in left and right, which causes the tractor to pull.

#### 4.3.2 Brake Adjustment Method:

- Adjustment on the brake pedal free path Loosen the lock nut (3) in the brake rod and turn the brake rod control fork (2) to change the length of the brake rod. Adjust the free stroke of the brake pedal (displacement of the brake pedal between the highest position and the position where the clearance between the brake hub (5) and friction plate (4) disappears) within 20–30mm. Make the length of brake rod (6) consistent. Then fasten the lock nut (3).
- Adjustment to equalize left and right braking (deviation) In case of inconsistent adjustment of the left and right brake and hard braking of the tractor during high-speed driving, the impression length of the left and right tires will become irregular, i.e. "deviation". Adjust the shorter brake rod by the side, shortening the impression length, or the longer brake rod by the side, lengthening the impression length, until the impression length of left and right tire are consistent, and braking is reliable. Then fasten the nut (3).

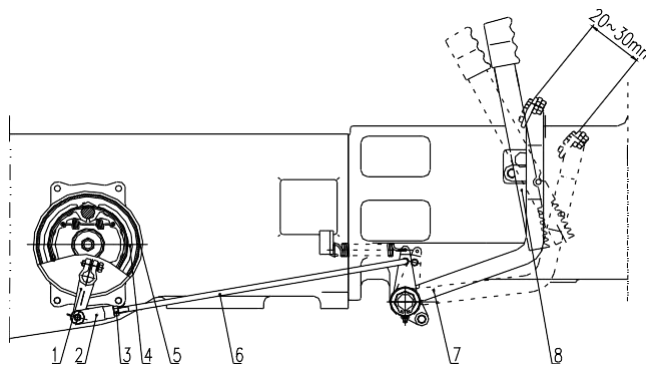

Figure 4-4 Brake System

1. Brake arm   2. Control fork   3. Lock nut   4. Friction plate  
5. Brake hub   6. Brake rod   7. Brake pedal   8. Lock plate components



**Warning:** Adjust the free strokes so that the left and right brake pedals are consistent, or the tractor will turn to one side during hard braking, which can cause an accident.

### 4.4 Differential Lock Adjustment

Adjustment of differential lock is performed through adjustment of the bolts (1 and 2). During the adjustment, the clearance between the right coupling (3) and left coupling (4) is about 2mm. Loosen the nut (2) and rotate the bolt (1) in, and the clearance increases. Rotate the bolt (1) out, and the clearance is reduced. After adjustment, fasten the nut (2).

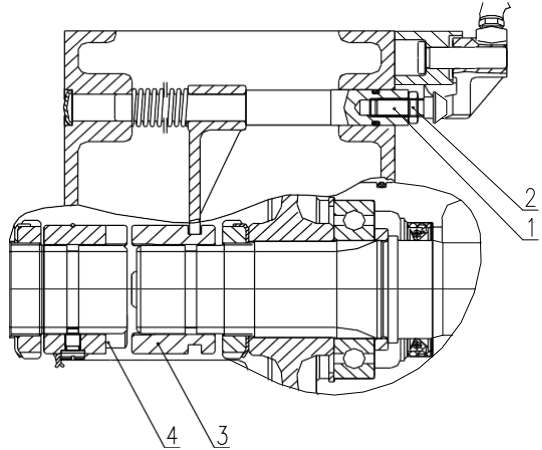

Figure 4-7 Differential Lock Adjustment

1. Adjustment bolt 2. Lock nut 3. Right coupling 4. Left coupling

## 4.5 Steering System Adjustment

### 4.5.1 Full Hydraulic Steering System Cautions

The FT series four-wheel drive tractor uses a full hydraulic steering system, as shown in the figure. Before leaving the factory, the steering system of the tractor is adjusted. Pay attention to the followings during use:

- Check the threaded connections **frequently** and tighten them if there is any looseness. There should not be any leakage at the connection when the full hydraulic steering system is working.
- If any steering difficulty is found or there is a steering failure during operation, inspect for the cause first. Do not turn the steering wheel too hard or dismantle the steering gear to prevent the parts from being damaged. Never have two people turn the steering wheel together.
- While installing the full hydraulic steering system, the steering gear should be coaxial to the steering shaft and there should be some clearance between the axial directions. Check the steering wheel for flexible resetting after the installation.
- Ensure that the oil is clean. Check the condition of the core and oil of the filter frequently. Checking method: dribble a drop of oil onto the a paper towel, and change the oil if there is a black spot in the center of the oil mark.
- The diverter valve is a precise part which should not be removed except in a clean environment. It should be cleaned with clean solvent.
- Before leaving the factory, the pressure of the diverter valve is adjusted. Do not dismantle or adjust it by yourself. Replace if bad.

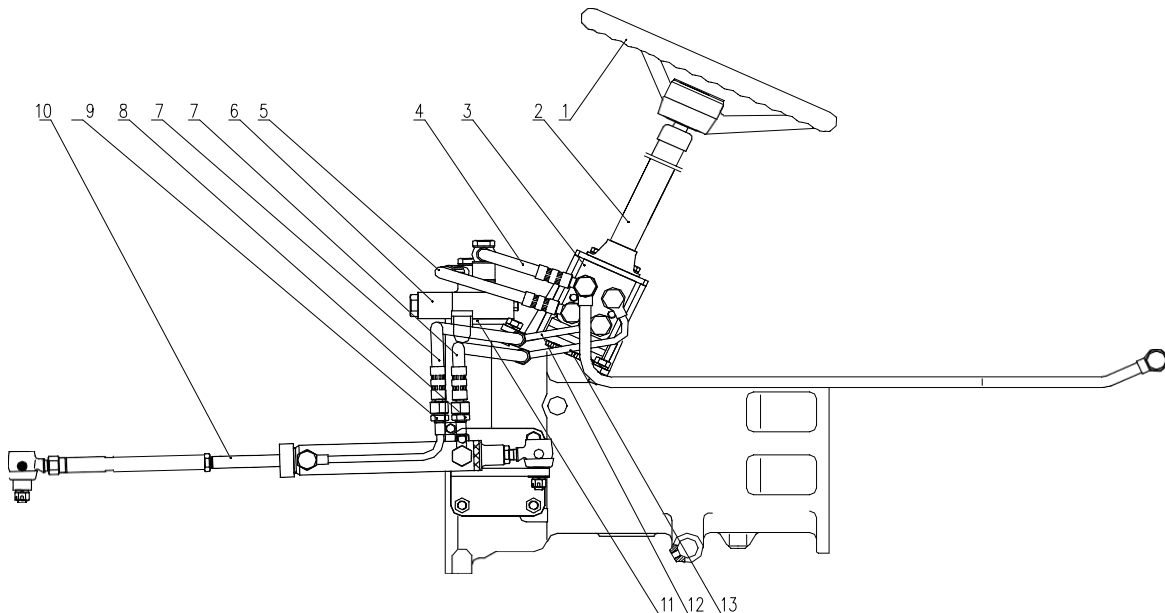

Figure 4-9 Full Hydraulic Steering System

1. Steering assembly    2. Steering cylinder column assembly    3. Hydraulic steering gear assembly    4. Overflow pipe assembly of the diverter assembly    5. Fuel intake pipe of the steering gear  
6. Single way stable diverter valve    7. Hose assembly of the oil cylinder  
8. Left transitional pipe of the oil cylinder    9. Right transitional pipe of the oil cylinder  
10. Drag link and steering oil cylinder assembly    11. Diverter valve bracket  
12. Right duct assembly of the oil cylinder    13. Left duct assembly of the oil cylinder

### 4.6 Front Drive Axle Adjustment

#### 4.6.1 Front Drive Axle Side Drive Adjustment

Adjustment of the mesh mark and meshing-teeth side clearance of the initiative gear and passive gear of the first level intermediate drive of side drive of the front drive axle can be realized by adjusting the adjusting shim (1).

Adjustment of the mesh mark and the meshing-teeth side clearance of the initiative gear and passive gear of the second level end drive can be accomplished by adjusting the adjusting shim (5). Clearance of the two meshing-teeth side clearances should be 0.25-0.45mm.

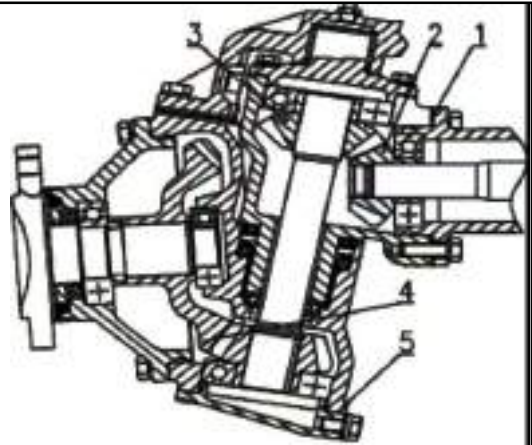

Figure 4-16 Front Drive Axle Side Drive Adjustment

1. Adjusting shim
2. Driving gear of intermediate drive
3. Driven gear of intermediate drive
4. Final driven gear
5. Adjusting shim

#### 4.6.2 Track Front of the Four-Wheel Drive Model

The track of front drive axle can be: 1073mm, 1193mm and 1257mm.

## 4.7 Hydraulic Lifting Mechanism Adjustment

Position the farm implement lifting handle in the neutral position, as shown in the figure, and then adjust the distance between the block on the push rod and the bumper pin fixed on the lifting shaft. The lifting position of the farm implement can then be controlled.

### 4.7.1 Highest Lifting Position

#### Adjustment of Farm Implements

During the adjustment, turn the external lifting arm (2) outwards first to adjust the distance between the lower end of the internal lifting arm (3) and the limiting pin (4) of the cover of back end of the riser to be 5mm (insert a block of about 5mm thick at the air plug (5)). Adjust the distance between the lifting bstop (6) and bumper pin (7) to be 9-10mm, and fix the block (6) on the return rod (8) with the bolt, and lock the nut with the bolt.

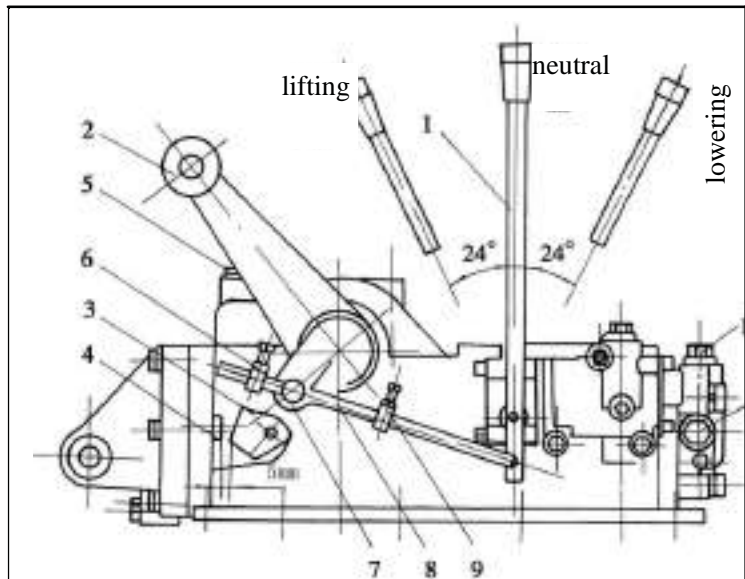

Figure 4-17 Adjustment of Lifting Position

1. Handle
2. External lifting arm
3. Internal lifting arm
4. Limiting pin
5. Air plug
6. Lifting stop
7. Bumper pin
8. Push rod
9. Lowering stop
10. Hydraulic output plug screw
11. Adjusting valve

### 4.7.2 Lowest Position Adjustment of Farm Implements

During the adjustment, turn the external lifting arm (2) downwards to the lowest position (at this time, the piston in the oil cylinder is pushed nearly to the lowest point). Adjust the distance between the lowering stop (5) on the return push rod (3) and bumper pin (4) to be 9-10mm, and then fix the stop (4) on the push rod with the bolt and nut.

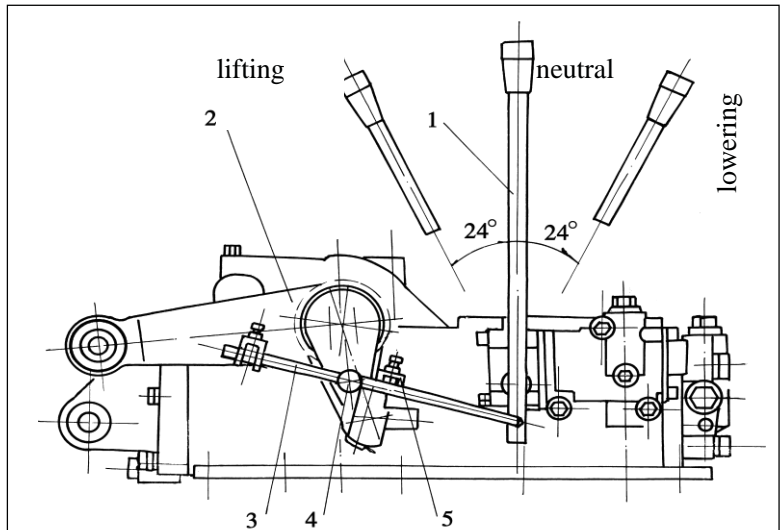

Figure 4-18 Lowering Position Adjustment

1. Handle
2. External lifting arm
3. Push rod
4. Bumper pin
5. Lowering stop



### 4.8 Battery Maintenance

#### 4.8.1 Maintenance of Maintenance-free Battery

- State Inspection of the Battery.

Normally the maintenance-free battery does not require any special maintenance. You can observe the power levels from the view hole of the liquid densimeter: Green=full power; Grey=lack of power; Dark=no power.

- The battery should be charged when the inspection hole becomes grey. It should be replaced when the inspection hole becomes dark.

- Battery Maintenance

- ☞ The battery should be stored in a clean, dry and well-ventilated area, the temperature range between 32–104°F. The battery should be handled with care and stored right side up.
- ☞ The battery terminal should be securely fixed to the power socket. Petroleum jelly should be used on the terminals to avoid fusion with the connectors and corrosion.
- ☞ Keep the battery outer terminals clean.
- ☞ Check the alternator output voltage regularly. The voltage should be  $(14.2\pm 0.25)V$ .

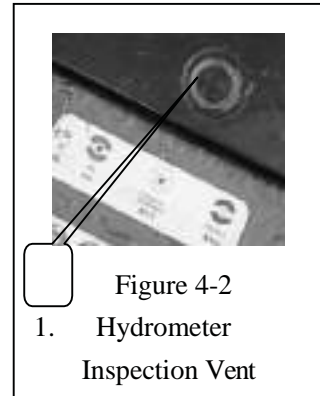

#### CAUTIONS:

1. When charging the battery, keep it in a ventilated area and far from open flames. Do not spill electrolytes on your clothing or your skin. This can cause serious injury.
2. Over charging can create over-heating of the battery. In order to avoid a potentially dangerous situation, the charging current should be reduced by half or charging should be stopped to lower the temperature. When the temperature is safe, charging can begin again. When charging is over, shut off the power in order to avoid a fire or explosion.

## Maintenance Instruction

### 4.9 Dry Air Cleaner Maintenance

#### 4.9.1 Dry Air Cleaner Instructions

- The main filter needs to be maintained every 50 to 100 hours in normal environments.
- In dusty environments, keep up the maintenance on the filter elements per 8 hours or per each work sequence.
- When the main filter element can not be cleaned or is worn out, it should change out with a new filter element.

#### 4.9.2 Dry Air Cleaner Maintenance Method

- Remove the filter element, clean the air cleaner with a brush and discard the dust in the rubber filter bag
- Rotate the filter element and blow the dust off from the inside of the filter element to the outside with less than 70 PSI of compressed air.
- Reinstall the filter element.

#### IMPORTANT NOTES:

The correct use and maintenance of the air cleaner directly relates to the service life of the engine, so it must be kept clean.

### 4.10 Fan Belt Tightening Adjustment

Press down on the middle part of the fan belt with your thumb and an applied force of 29.4-49.0N and a pushing distance is  $15 \pm 3$  mm. If the belt does not conformed, adjustment is required, with the method shown as follows:

Release the fixing nut on the alternator adjusting bracket, rotate the alternator away from engine to achieve proper tension, make the adhesive tape tense and then screw down the fixing nut on the alternator bracket.



Figure 4-21 Fan Belt Tightening Adjustment

### 4.11 Engine Oil Sump Level Check and Oil Replacement

(1) Remove the oil dipstick (A) on the left front of the oil pan and check if the oil level is between the upper scale mark and lower scale mark. If the oil level doesn't reach the lower scale mark, add oil to the recommended level.

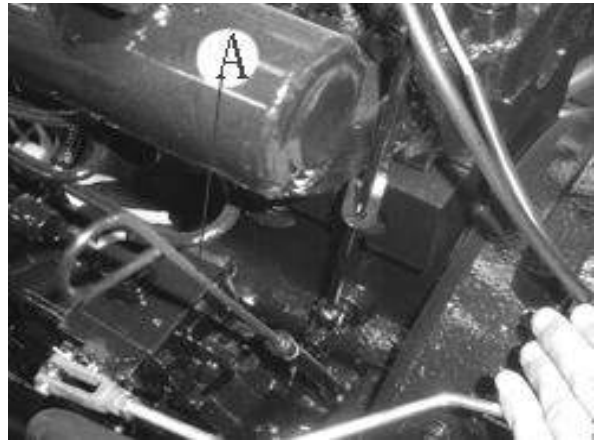

Figure 4-22 Engine Oil Quantity Check

(2) Before maintenance and replacement of the oil, preheat the engine. When the engine oil temperature reaches 50°C~60°C, unscrew the drain plug (A) below the oil pan, discharge all of the dirty oil, and refill with new oil.



Figure 4-23 Changing the Oil in the Engine Oil Pan

**IMPORTANT NOTE:** Never mix new and old engine oil or blend different brands of oil, as this can damage the engine. Replace the engine oil strictly in accordance with time limits recommended in the Operation Instruction of the Diesel Engine.

### 4.12 Fuel Filter Maintenance

The fuel filter is in the front upper area on the left side of the engine. Cleaning the paper filter element of the cleaner is not allowed. The filter element should be replaced when the engine works for 200 hours. The detailed maintenance process is implemented according to the regulations of the shop instructions.



Figure 4-24 Fuel Filter Maintenance

## Maintenance Instruction

### 4.13 Engine Oil Filter Maintenance

The engine oil filter (A) is located in the middle lower part on the left side of the engine. The oil filter should be replaced according to the recommended maintenance schedule.



Figure 4-25 Engine Oil Filter Maintenance

### 4.14 Lifter Hydraulic Oil Filter Maintenance

The lifter hydraulic oil filter (A) is located inside the left upper part of the raiser shell (below the driver seat). The cleaning method is as follows: Loosen the 3 M8 bolts. Take out the reticulated filter element, clean with solvent and let air dry. When it becomes hard to clean the filter element or the filter element is damaged, it should be replaced.

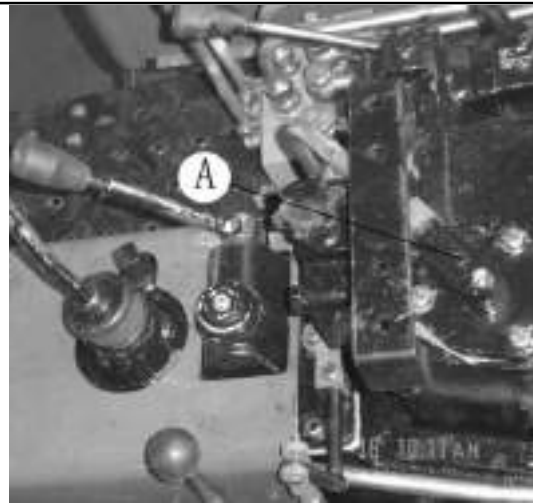

Figure 4-26 Lifter Hydraulic Oil Filter Maintenance

### 4.15 Front Drive Oil Level Check

When checking the front drive oil level, the assembly parts (A) measuring the oil dipstick should be unscrewed and the oil level should fall within the scale range of the dipstick, otherwise engine oil needs to be added. When replacing the engine oil, unscrew the main drive drain plug and the final drive drain plugs on the left and right. Discharge all of the dirty oil, retighten the plug screw and add new engine oil to (A). After a waiting period, if there is engine oil leaking from (B), this means that the engine oil is full.

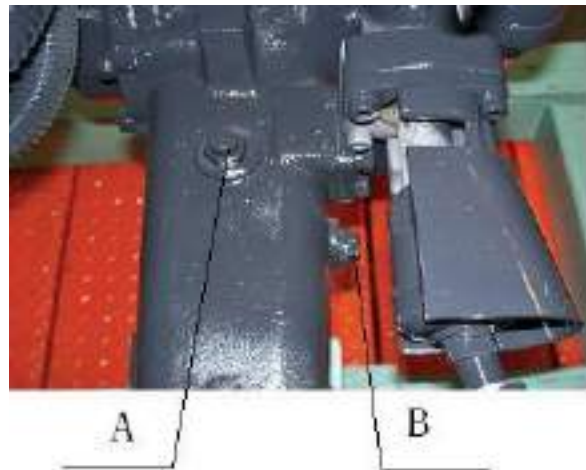

Figure 4-27 Front Drive Oil Level Check

## Instruction on maintenance

### 4.16 Transmission Mechanism Maintenance

Pull out the oil dipstick on the right of the main gear lever (as show in in the figure), wipe it clean and then insert the oil dipstick. If the oil level is lower than the lower scale mark, refill the transmission oil to a level between the upper scale mark and the lower scale mark of the dipstick (measure the level 5 minutes after adding the oil). When replacing the transmission oil, remove the drain plug at the bottom of the transmission case, discharge all of the dirty oil and then tighten the drain plug and refill with new transmission oil.

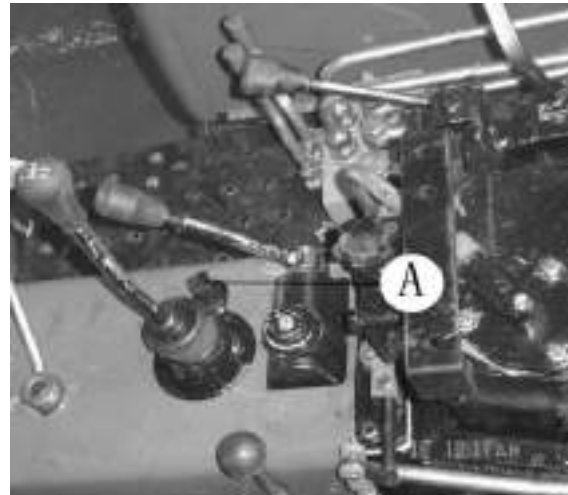

Figure 4-28 Transmission Mechanism Maintenance

**Note:** When checking the oil level, stop the tractor on level ground and switch off the engine.

### 4.17 Lifter Assembly Maintenance

- Unscrew the fill plug at the back upper part of the lifter shell (as shown in the figure). If the oil level is lower than the upper scale mark of the dipstick refill.



Figure 4-29 Lifter Oil Dipstick

- When replacing the trans-hydraulic oil, unscrew the drain plug (A) on the back lower part of the lifter, drain the dirty oil, tighten the plug and refill with new trans-hydraulic oil.

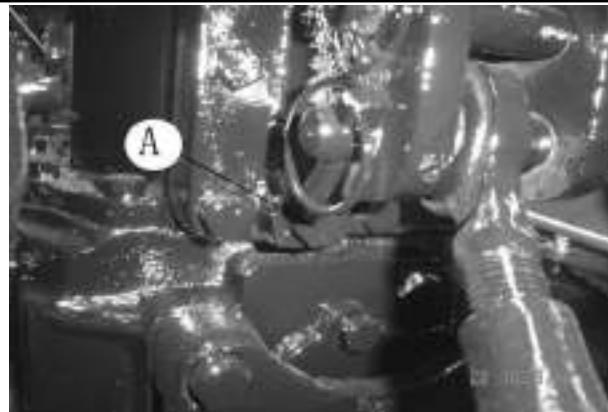

Figure 4-30 Lubrication Oil Oil Plug

**NOTE:** Stop the tractor on level ground, descend the lift arm to the lowest position, switch off the engine and then check the oil level.

## Maintenance Instruction

### 4.18 Fuel Tank Maintenance

- Stop the tractor on level ground, switch off the engine and then remove the drain plug below the fuel tank. Discharge the sedimented dirt at the bottom of the fuel tank.



Figure 4-31 Fuel Tank Maintenance

- The sediment bowl of the fuel tank gathers water and impurities. When maintaining the fuel tank, the sedimented dirt in the sediment bowl B at the bottom of the fuel tank should be discharged simultaneously.

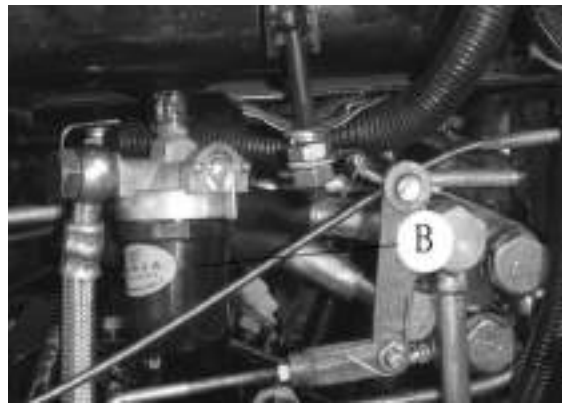

Figure 4-32 Fuel Tank Sediment Bowl

### 4.19 Tire Inflation Pressure

Check the tire pressure with the an air pressure guage. The tire inflation pressure is shown in the Technical Specifications of FT Series Tractor.



**NOTE:** If the tire pressure is too high or too low, it will shorten the service life of the tires, influence the tractor's operation and potentially cause accidents.



## Maintenance Instruction

### 4.20 Engine Cooling System Maintenance

The engine cooling system uses antifreeze only. In general, antifreeze is good for a period of 2 years or 1600 hours and then should be replaced, the cooling system should be flushed before new antifreeze is added. (Note : Antifreeze must be used to prevent freezing in winter) Close the radiator drain valve, add a 50/50 anti-freeze mix and run the engine for 20 minutes. Check for leaks and fluid level once engine has cooled down.



Picture 4-33 Engine Cooling System Maintenance

**NOTE:** During winter, water in the radiator can freeze, causing the engine block to crack. Always use antifreeze in the radiator.

### 4.21 Bleeding the Fuel System

If a tractor is out of commission for a long time, after replacing the diesel engine filter or with an empty fuel tank, air could enter the fuel line, making it difficult to start the engine. This problem can be fixed by following the steps below but first the fuel tank should be filled and the fuel cutoff switch turned on:

- Unscrew the bleeder screw (A) on the fuel filter and toggle the fuel supply pump draw knob (B) up and down until the diesel is discharged out of the hole of the bleeder screw and there are no bubbles.
- Tighten the bleeder screw (A), then unscrew the fuel injection pump bleeder screw. Pump the fuel supply hand primer knob (B) until the diesel is discharged out of the hole of the bleeder screw and there are no bubbles, then tighten the bleeder screw (C).

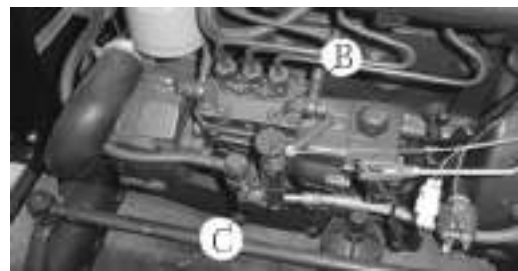

Picture 4-34 Exhausting the Fuel System

**NOTE:** The engine runs on high-quality light diesel fuel and must meet specifications. Generally, light diesel No. 2 is applied during the summer while No.1 is used during the winter.

## Storage

### 5. Storage

When the tractor needs to be stored for a period of time (more than one month) it should be kept in proper storage building. The storage facility should provide protection from the elements so as to prevent dirt rust and corrosion.

Before storing the tractor, it must undergo a thorough cleaning, adjustment and tightening of various joint parts, subject to the technical maintenance requirements, in compliance with the duty hours, so that the tractor remains on good technical condition.

**IMPORTANT NOTE:** During long periods of non-use, it is very important to preserve and maintain the tractor. If special steps are not taken, the life of the tractor could be shortened and parts could deteriorate.

#### 5.1 Causes of the Damages

There are several main causes of tractor damage while in storage:

- **Rust:** During the storage period, dust and moisture in the air get in to the tractor. This can cause contamination and rusting of the components. When pistons, valves, bearing and gears, etc. stay in one place for an extended period of time, they will lose lubricant film protection, which produces rust and causes parts to stick and seize up.
- **Aging:** Some components are made with rubber and plastic. Rubber and plastic will age and deteriorated, growing brittle and rot under ultraviolet light.
- **Distortion:** Components such as drive belt and tires etc may become distorted in shape.
- **Others:** Electric parts are more easily affected in damp conditions and the battery can discharge over time.

#### 5.2 Tractor Storage

- Prior to storing the tractor, give the tractor and its surroundings a good once over to ensure that the tractor can be stored with minimal effect
- Remove the battery, coat the terminals with petroleum jelly and keep it in a dark, well-ventilated room with a consistent moderate temperature.
- Drain the machine oil from the engine before it has a chance to cool. Replace the oil with fresh oil and run the tractor for 10 minutes to allow the lubricant to stick to the parts and components.
- Add lubricant to the various lubrication points.
- Coat the contact surface of the electric appliances, tie-ins and non-painted metal parts with anti-corrosion spray.
- Loosen the engine fan belt and remove them if necessary. Wrap the belts up securely and spray the pulley groove with a rust-proof agent. If possible, cover all chips and unpainted spots on the tractor with a preservative.
- Drain the diesel fuel from the tank or add diesel fuel conditioner.
- Seal any engine opening such as intakes/outlets with the protective material to prevent foreign matter, dust and moisture from getting in.
- Place all control handles in the neutral gear position (including electrical system switches and the stationary brake system).



## Storage

- The tractor should be parked in a dry, well-ventilated area. Never store your tractor around flammables or corrosive materials. If you don't have access to such an area, make sure that you cover the tractor with a waterproof covering.
- Any parts taken from the tractor should be cleaned, wrapped and stored in a dry area.

### 5.3 Tractor Storage Maintenance

- Check on the tractor and its parts at least once a month to see whether there is any rust, corrosion, aging and distortion happenings
- Start the tractor bi-monthly and allow the engine to run. This will prevent interior rust.
- If possible, drive the tractor once every three months at low speed for 20 to 30 minutes. This is a great way to see how the tractor is fairing in storage.
- Clean dust off the top of the battery with dry cloth, and check the charge level. The battery can go dead even when not in use. Recharge the battery once a month.
- When transporting long distances by train, truck, or trailer the gears should not be engaged. Transporting the tractor with the gears engaged, will drive the parts such as the gears, bearings, crankshaft and pistons, which can rub without lubricant and cause damage.

**IMPORTANT:** If you cannot carry out the anti-rust treatment and the tractor needs to be out of use for several months or longer, at a minimum, replace the machine oil and oil filter. Start the tractor once every month and run the tractor at low speed for 20–23 minutes at a minimum. Check to make sure everything is operating properly and keep the tractor clean and try to limit the amount of corrosion that could result from dust and wet conditions.

### 5.4 Removing Tractor from Storage

- Remove the grease used for anti-rusting
- Reopen the various sealed up nozzles and clean the tractor
- Check coolant, machine oil, and diesel fuel and lubricate all of the lubrication points according to the provisions.
- Remove any anti-rust agent in the belt grooves and reinstalls and/or adjust the belts. (See: Engine Instruction for Use and Maintenance)
- Reinstall the battery and check the terminals.
- Check that all of the circuits, hoses and lines are properly connected.
- Check air pressure in tires.

**NOTE:** Please refer to the “Engine Instruction for Use and Maintenance” for details on engine storage and removing tractor from storage.

## Storage

---

### 6. Transportation

If the tractor is displaced by self-drive, local traffic regulations should be strictly observed with at least 180 feet of distance maintained between vehicles. If the tractor is being transported, the following points should be satisfied:

1. A smooth, level spot should be selected for loading and unloading the tractor.

If available, a special unloading platform should be used.

3. Have one helper available for guiding and make sure the area is clear of all others.
4. After loading, the lift should be placed at the lowest position, the hand brake set, the reverse gear engaged, the key taken out, and the master switch turned off.
5. The front and rear tires should be fixed in place with straps in an 8 pattern. Both front and rear tires should be blocked and the rear axle secured with straps.
6. The tractor should be pulled inside as far as possible and the rear view mirror may be taken down when necessary
7. When tunnels and bridges are encountered, full attention must be paid to the load height, and speed should be adjusted for road safety.
8. While unloading, the hand brake should be released first. The drive gear should then be engaged and the tractor should be unloaded slowly and carefully.

## Technical Specifications for XT Series Tractors

### 7. Technical Specifications for FT Series Tractors

#### 7.1 Technical Specifications for 2W Drive FT Series Tractors

Type		Unit	20FT	22FT	25FT
Type		—	Wheeled 4x4		
Outline size	Length (incl. rear suspension)	mm	2890/3030(excl. front counterweight)		
	Width	mm	1470		
	Height(up to the top of muffler)	mm	1907,or1933/1863,or1889		
Wheelbase		mm	1577/1690		
Tread	Front wheel	mm	1100、1200、1300(adjustable)		
	Rear wheel	mm	1150~1200、1300~1350(adjustable)		
Ground clearance		mm	320(tires 8.3-24),or 347.5(tires 9.5-240[gearbox, down-side to ground])		
Turning circle radius	Single sided brake	m	2.5±0.2/2.6±0.2		
	Non-single sided brake	m	2.9±0.2/3.0±0.3		
Structural mass		kg	990/1040		
Minimum used mass		kg	1100/1150		
Mass distribution	Front wheel	kg	470		
	Rear wheel	kg	680		
Counterweight	Front counterweight	kg	54		
	Rear counterweight	kg	124		
Nominal traction power		kN	4.3	4.5	4.8
PTO shaft power		kW	13	14.5	16
Number of gears		—	8F+2R、8F+8R、16F+4R		
Theory speed (calculated with the rear wheels 9.5-24)	Common gear	Drive gears	2.06, 3.14 4.92, 6.79 9.52, 14.5 22.76, 31.37		
			Reverse gear	2.71 12.53	
	Shuttle gear	Drive gears	2.06, 3.14 4.92, 6.79 9.52, 14.5 22.76, 31.37		
			Reverse gear	1.92, 2.92 4.59, 6.32 8.87, 13.51 21.2, 29.22	
	Clamping gear	Drive gears	2.06, 3.14 4.92, 6.79 9.52, 14.5 22.76, 31.37		
			Clamping drive gear	0.44, 0.67 1.06, 1.46 2.04, 3.11 4.88, 6.73	
		Reverse gear	2.71 12.53		

## Technical Specifications for XT Series Tractors

Type			Unit	20FT	22FT	25FT	
		Clamping reverse gear		0.58, 2.69			
Engine	Type		—	KM385T		KM385T	
	Type		—	Vertical, water cool, 4 strokes diesel			
	Number of cylinders		—	2/3			
	Cylinder diameter x stroke		mm	95×105/80×90		100×105/85×90	
	Combustion chamber mode			straight-injection or swirl			
	Nominal power		kW	14.7	16.2	18.4	
	Nominal rotate speed		r/min	2350	2350	2350	
	Nominal fuel consumption rate on the operating condition		g/kWh	≤266.6/≤278.8 or ≤268 (KM385BT)			
	Nominal oil consumption rate on the operating condition			≤2.04/≤2.72			
Auxiliary turning brake system	Frame assembly		—	Frame/semi-frame			
	Front shaft		—	Invert U tube			
	Tire pressure	Transport	Front wheel	kPa	200~250		
			Rear wheel		120~150		
		Plough	Front wheel		200~250		
			Rear wheel		100~120		
	Tire specification		Front wheel	—	4.00-16, or 5.00-16		
			Rear wheel	—	8.3-24(paddy field tires), or 9.5-24(conventional)		
	Front wheel toe-in		mm	4~10			
	Steering gear		—	Worm-roller or hydraulic steering gears			
	Max. rotating angle, front wheels			50°			
Brake		—	Shoe brake				
Trailer brake		—	Pneumatic brake				
Working device	Deep plough control mode		—	Position and floating control			
	Hydraulic oil pump		—	CBJ30-E06-W5B, or pump CBJ30-E14-W5B / pump CBJ30-E14L			
	Oil cylinder diameter x stroke		mm	63×100			
	Opening pressure of the system safety valve		Mpa	17.5-18			
	Max. lifting power (610mm behind rear suspension point)		kN	3.3	3.3	3.3	
	Suspension system		mm	Rear-mounted, three-point Spherical Hinge, Cat. I			
Working device	Pin hole diameter of upper suspension point		mm	Φ19			
	Pin hole diameter of bottom suspension point		mm	Φ22			
	Hydraulic power take-off	Simple hydraulic power take-off	—	Rapid exchange joint 1pc			
		Multiple direction valve hydraulic power take-off	—	Rapid exchange joint 2pcs			
	PTO shaft(r/min)			Non-independent, 540/720(540/1000 optional)			
	PTO shaft diameter		mm	ø35, 6 teathed rectangle spline shaft			
	PTO shaft position		mm	Ground clearance 468, or 494			
	PTO shaft revolving direction		—	Clockwise(viewed from the tractor tail)			
	Height of towing pothook		mm	Ground clearance 468, or 494			

## Technical Specifications for XT Series Tractors

Type		Unit	20FT	22FT	25FT
	Diameter of pothook	mm	φ20		
Transmission system	Clutch	—	Single-plate, dry type, spiral spring pressed, constant joint, single action or non-independent double actions.		
	Gearbox	—	Combined (4+1) x 2; 8 drive gears; 2 reverse gears, clamping gear available for option (i.e.16F+4R)		
	Central transmission	—	Spiral bevel gear		
	Differential	—	2 planet bevel gears		
	Differential lock	—	Jaw positive-contact		
	Final transmission	—	Built-in, single straight-toothed Spur Gear		
Electric appliance instrument system	Electric appliance system	—	12 volts, negative earth, twin-wire		
	Battery	—	6-QA-90(or 6—QW-70 service-free battery)		
	Regulator	—	FT141,or JFT149		
	Head lamp	—	12V, 45W/40W: 2 pcs		
	Front direction indicator	—	12V, 5WL 2 pcs		
	Rear combined lamps	—	12V, 21W/21W/5W, reflector(red):		
	Rear working lamp	—	2 pcs, each.		
	12V, 28W: 1pc	—	Instrument Ampere meter, oil pressure meter, and water temp. meter		
	Starter switch	—	JK430G		
	Cold start device	—	Preheating plug		
Perfusion volume capacity	Water tank radiator	L	10		
	Fuel tank		21		
	Engine oil pan		3.5		
	Oil, gearbox		11		
	Hoister oil		9		
	Water tank radiator		10		

**NOTE:**

Data behind refer to the parameters required for the 3 cylinder engine

## Technical Specifications for XT Series Tractors

### 7.2 Technical Specifications for 4W Drive FT Series Tractors

Type		Unit	FT204A	FT224A	FT254A
Type		—	Wheeled 4x4		
Outline size	Length (incl. rear suspension)	mm	3030(excl. front counterweight)		
	Width	mm	1470		
Wheelbase		mm	1673/1743		
Tread	Front wheel	mm	1150		
	Rear wheel	mm	1150~1200、1300~1350(adjustable)		
Ground clearance		mm	228 (tires 8.3-24), or 254 (tires 9.5-24[gearbox, down-side to ground])		
Turning circle radius	Single sided brake	m	2.6±0.2		
	Non-single sided brake	m	3.1±0.3		
Structural mass		kg	1080/1130		
Min. used mass		kg	1180/1230		
Mass distribution	Front wheel	kg	500		
	Rear wheel	kg	680		
Counterweight	Front counterweight	kg	54		
	Rear counterweight	kg	124		
Nominal traction power		kN	5.4	5.8	6.5
PTO shaft power		kW	13	14.5	16
Number of gears		—	8F+2R, or 16F+4R		
Estimated speed (calculated with the rear wheels 9.5-24)	Common gear	Drive gears	2.06, 3.14 4.92, 6.79 9.52, 14.5 22.76, 31.37		
		Reverse gear	2.71 12.53		
	Shuttle gear	Drive gears	2.06, 3.14 4.92, 6.79 9.52, 14.5 22.76, 31.37		
		Reverse gear	1.92, 2.92 4.59, 6.32 8.87, 13.51 21.2, 29.22		
	Clamping gear	Drive gears	2.06, 3.14 4.92, 6.79 9.52, 14.5 22.76, 31.37		
		Clamping drive gear	0.44, 0.67 1.06, 1.46 2.04, 3.11 4.88, 6.73		
		Reverse gear	2.71 12.53		
		Clamping reverse gear	0.58, 2.69		

## Technical Specifications for XT Series Tractors

Type		Unit	FT204A	FT224A	FT254A	
Engine	Type	—	TY295IT/Y380T,or LL380T		Y385T or KM385BT	
	Type	—	Vertical, water cool, 4 strokes diesel			
	Number of cylinders	—	2/3			
	Cylinder diameter x stroke	mm	95×105/80×90		100×105/85×90	
	Combustion chamber mode	—	straight-injection or swirl			
	Nominal power	kW	14.7	16.2	18.4	
	Nominal rotate speed	r/min	2200	2300,or 2350	2350	
	Nominal fuel consumption rate on the operating condition	g/kW h	≤266.6/≤278.8 or ≤268 (KM385BT)			
	Nominal oil consumption rate on the operating condition		≤2.04/≤2.72			
Transmission system	Clutch	—	Single-plate, dry type, spiral spring pressed, constant joint, single action or non-independent double actions.			
	Gearbox	—	Combined (4+1) x 2; 8 drive gears; 2 reverse gears, clamping gear available for option (i.e.16F+4R)			
	Central transmission	—	Spiral bevel gear			
	Differential	—	2 planet bevel gears			
	Differential lock	—	Jaw positive-contact			
	Final transmission	—	Built-in, single straight-toothed Spur Gear			
	Front drive axle	Central transmission, front	—	Spiral bevel gear		
		Differential	—	2 planet bevel gears		
		Final transmission, front	—	Single straight-toothed Spur Gear		
Transfer case	—	Straight-toothed column gear joint separation device				
Auxiliary turning system	Tire specification	Front wheel	—	6.00-14		
		Rear wheel	—	9.5-24(conventional)		
	Tire pressure	Transport	kPa	120~150		
		Plough	kPa	100~120		
	Front wheel toe-in	mm	6~12			
	Steering mode	—	Hydraulic pressure steering			
Max. rotating angle, front wheels	angle	50°				
Perfusion volume capacity	Water tank radiator	L	10			
	Fuel tank		21			
	Engine oil pan		3.5			
	Oil, gearbox		11			
	Hoister oil		9			
	Oil, frontal drive axle		4.5			

Note:

Data behind refer to the parameters required for the 3 cylinder engine

---

## 8. Disassembly and disposal

After the machine reaches the end of its service life, for your personal safety and the protection of the environment, please deliver it to the licensed company specialized in the disassembly and recycle of such products.

When done, the tractor should be disassembled in a sequence, from top to bottom, outside to inside. In case of large objects or heavy mass, a special hoisting mechanism should be used. Please take the battery to a battery recycling company and collect all waste oil for proper treatment.



**WARNING:** The battery electrolyte is corrosive. Take precautions to ensure that it does not get in your eyes or on your skin or clothes. If this were to happen, clean the affected area immediately with water and seek medical treatment as soon as possible.



**ATTENTION:** Battery acid and machine oil are contaminants. Contaminants should be disposed of properly following local laws so as not to cause any damage to the environmental.

Breaking down a retired tractor requires special tools and practical experience. A lack of either of these can add up to serious injury to damage to the environment.



**WARNING:** When disassembling large or heavy objects (i.e., a tractor) a special hoisting mechanism must be used and care should be taken to ensure safety at all times.



## 10. Appendixes

### 10.1 Tractor Fuel, Oils and Solutions

Table 10-1 Tractor Fuel Oils and Solutions

Application Locations of Oils and Solutions	Fuel, Oils and Solutions	
Fuel Tank	International standard	Adopt ASTM D-975 fuel. Under general air temperatures, use 2-D grade fuel; when ambient temperatures are below 32 F, use 1-D grade fuel.
Engine Sump	International standard	Engine sump, injection pump, and governor use viscosity grades compliant with SAE viscosity classifications. Use all-season SAE 15W/40 multi-grade oil. Quality class should comply with API CD grade standard.
Water radiator	Use a 50/50 blend of antifreeze and water.	
Gearbox-rear axle, hydraulic lifter, and front drive axle	International standard	Drive system and lifter, hydraulic steering, and central and final drives of front drive axle can use MF1135 (Massey Ferguson), M2C 86A (Ford), or J20A (John Deer) general-purpose oil.
Steering fluid	International standard	Same as above.
Oil Fittings/ zirks	International standard	Use a multipurpose grease.
Battery		Maintenance free
<p><b>IMPORTANT NOTES:</b></p> <p>Hybrid use of oils of different brands and manufacturers can affect the service performance of the machine. Their use is not recommended.</p>		



**NOTE:**

1. Never fill fuel into the fuel tank while the diesel engine is running, as doing so, could cause an accident.
2. When working in severe sunlight, the fuel tank should not be filled up, or the fuel may overflow as a result of expansion. The overflowed fuel should be cleaned up immediately.

## 10.2 Major Bolts and Nuts Tightening Torque Table

Table 10-2 Major Bolts and Nuts Tightening Torque Table

Name and Assembly Position	Thread Specification	Tightening Torque[N·m]	Tightening Torque [LB FT]
Connecting bolt and nut for the engine and the clutch housing	M10	41~51	30~37
Connecting bolt for the clutch housing and the rear axle casing	M14×1.5	123~154	90~113
Fixing bolt for one- and two-axle bearings	M10	41~51	30~37
Fixing bolt for the interlocking wedge	M10	50~70	36~51
Fixing bolt for the driven spiral bevel gear	M10×1.25	45~55	33~40
Connecting bolt for the drive shaft housing and rear axle casing	M12×1.5	73~89	53~65
Connecting bolt for the drive wheel hub and radials	M18×1.5	397~457	293~337
Lock nut for the front axle tie rod	M16X1.5	122~149	90~110
Connecting bolt for the front outer shaft and front inner shaft	M14	122~149	90~110
Connecting bolt for the front drive wheel, front wheel hub and radials	M14×1.5	178~218	131~160
Connecting bolt for the front axle and bracket	M16	182~222	134~164
Connecting bolt for the front bracket and battery tray	M12	73~89	53~65
Connecting bolt for the bracket and engine	M12	73~89	53~65
Connecting bolt for the bracket and engine	M14X1.5	126~154	93~114
Connecting bolt for the raiser housing and rear axle casing	M10	41~51	30~37
Connecting bolt for the direction converter and clutch housing	M14	122~149	90~110
Connecting bolt for the gag lever post bracket	M14	122~149	90~110



**WARNING:** When tightening the major bolts and nuts on the tractor, torque wrenches should be used to avoid a reduction in machine performance and personal injury, which is caused by a failure to meet the requirements for the tightening torques.

### 103 Tractor Rolling Bearing

Table 10-3 Schedule of Tractor Rolling Bearings

Sequence No.	Code	Bearing Code	Name of Bearing	Installation Position	Quantity
1	GB/T 276	6203-Z	Deep groove ball bearing	Front end of clutch axle	1
2	GB/T 276	6006	Deep groove ball bearing	Front end of power take-off drive shaft	1
3	GB/T 276	6206	Deep groove ball bearing	Front end of transfer case output shaft	1
4	GB/T 276	6207	Deep groove ball bearing	Back end of power take-off shaft	1
				Intermediate drive driving gear	2
5	GB/T 276	6208	Deep groove ball bearing	Front drive axle back-end reduction driving gear	2
				Front drive axle intermediate drive driven gear	2
6	GB/T 276	6210	Deep groove ball bearing	External end of drive shaft	2
7	GB/T 276	6211	Deep groove ball bearing	Internal end of drive shaft	2
8	GB/T 276	6305	Deep groove ball bearing	Back end of power take-off drive shaft	1
				Front end of power take-off drive shaft	1
				Back end of transfer case output shaft	1
9	GB/T 276	6307	Deep groove ball bearing	External end of semi-minor axis	2
10	GB/T 276	6207N	Deep groove ball bearing	Front end of the first shaft of gearbox	1
11	GB/T 283	NT305E (for single-action clutch)	Cylindrical roller bearing	Back end of the first shaft of gearbox	1
		NT206E (for double-action clutch)			
12	GB/T 283	NUP2207E	Cylindrical roller bearing	Back end of the second shaft of gearbox	1
13	GB/T 297	31305	Conical roller bearing	Front end of the second shaft of gearbox	2
14	GB/T 297	32011	Conical roller bearing	Both ends of differential gear	2
15	GB/T 297	977907	Bearing	Lower end of direction converter worm	1
		977907K	Bearing	Upper end of direction converter worm	1
16	GB/T 297	30205	Conical roller bearing	External end of front wheel hub	2
17	GB/T 297	30206	Conical roller bearing	Internal end of front wheel hub	2
18	GB/T 301	51106	One-way thrust ball bearing	Steering knuckle vertical shaft	2
				Lower end of front final drive housing	2
19		688808 (for single-action clutch)	Release bearing	Release bearing for clutch	1

Sequence No.	Code	Bearing Code	Name of Bearing	Installation Position	Quantity
		688711 (for double-action clutch)			
20	GB/T 5846	K202417	Rolling needle bearing	Transfer-case idle shaft	2
21	GB/T 5846	K253120	Rolling needle bearing	Transfer-case output shaft	2
22	GB/T 5846	K283327	Rolling needle bearing	~ Gear of driven gear	2
23	GB/T 5846	K303527	Rolling needle bearing	Range stationary gear	2
24	GB/T 292	7206AC	Angular contact ball bearing	Internal end of front drive shaft	2
25	GB/T 292	7208AC	Angular contact ball bearing	External end of front drive shaft	2
26	GB/T 297	32007	Tapered roller bearing	Middle part of driving bevel gear shaft	1
27	GB/T 297	32010	Tapered roller bearing	Front axle differential carrier	2
28	GB/T 297	32207	Tapered roller bearing	Front end of driving bevel gear shaft	1
29	GB/T 5846	K424822	Rolling needle bearing	IV gear of driving gear	1
				III gear of driving gear	1

#### 10.4 Tractor Chassis Sealing Member

Table 10-4 Schedule of Tractor Chassis Sealing Member

Part	Specification		Installation Position	Quantity
Gearbox	GB/T 9877.1 Self-seal packing for revolving shaft	B35×55×8	Front end of the first shaft	2
		FB35×55×8	Inside the bearing cap of power take-off shaft	2
		B50×72×8	Outer flank of drive shaft	6
		B55×75×8	Inner flank of drive shaft	4
	JB/T2600 reinforced seal	PD50×80×12	Final drive driving gear shaft	2
	GB/T3452.1 O-rings	11.8×1.8G	PTO shift fork shaft	1
		15×2.65G	Differential lock declutch shift shaft	1
		22.4×2.65G	Reverse gear shaft	1
		28×3.55G	Final drive driving gear shaft	2
		67×3.55G	2 <sup>nd</sup> -shaft front bearing saddle	1
103×3.55G		Rear-axle bearing saddle	2	
	112×3.55G	Drive shaft sleeve	2	
Brake	GB/T3452.1 O-rings	15×2.65G	Brake camshaft	2
Front shaft	Non standard (see the drawing)	Vertical shaft oil seal 40×48×6.5	Lower end of steering knuckle	2
		Half shaft oil seal 38×74×11.5	Front wheel hub	2
	GB/T3452.1 O-rings	30×3.55G	Upper ends of left and right steering knuckles	2

Part	Specification		Installation Position	Quantity
			Both ends of rocking shaft	2
Raiser	JB/T2600 reinforced seal	PD42×62×10	Lift shaft	2
	JB/T 982 Sealing gasket	10×13.5	Bleeder plug	1
		10×13.5	Cylinder head	2
		18×22	Hydraulic output hollow bolt	1
		36×42	Oiling ventilation plug assembly	1
		GB/T3452.1 O-rings	71×2.65G	Sealing part of cylinder sleeve and housing
	17×2.65G		Cylinder head regulating vavle	1
	53×5.3G		Piston and oil cylinder tube	1
	53×5.3G		Piston and oil cylinder tube	1
	Distributor	GB/T3452.1 O-rings	9×2.65G	Handle shaft, safety valve seat
Composition face between distributor and lifter housing				1
13.2×2.65G			Safety valve holddown screwed-in plug	1
15×2.65G			Composition face between distributor and lifter housing	1
19×2.65G			Composition face between distributor and lifter housing	1
Oil pump and oil circuit	GB/T3452.1	O-rings 18×2.65G	Oil pickup	1
Transfer case	JB/T2600 oil seal	SG30×45×8	Transfer-case output shaft	1
	GB/T3452.1 O-rings	12.5×1.8G	Transfer-case shift shaft	1
		36.5×2.65G	Front end of rear-jacket welding case	2
		53×2.65G	Back end of rear-jacket welding member	1
Front drive axle	JB/T2600 Skeleton oil seal	PG45×65×10	Oil seal housing washer	2
		SD45×70×10	Front drive shaft	2
		SD50×70×12	Lower end of vertical shaft sleeve	2
		W50×72×7	Lower end of vertical shaft sleeve	2
	GB/T 3452.1 O-rings	33.5×3.55G	Driving bevel gear shaft	2
		34.5×3.55G	Bearing cap	2
		40×3.55G	Front pendulum shaft	2
		56×2.65G	Dust-proof pipe saddle	1
		67×3.55G	Front pendulum shaft	2

Part	Specification	Installation Position	Quantity
	75×2.65G	Bearing cap	2
		External end of half shaft sleeve	2
	80×3.55G	Rear bearing	2
	85×3.55G	Driving bevel gear bearing saddle	2
	170×3.55G	Drive shaft cap	2
	175×3.55G	Internal end of half shaft sleeve	2



**NOTICE:** Before using a supporting farm implement, the owner/operator should read the machines “operation and maintenance manual” carefully and become familiar with the construction, performance and method of operation to avoid machine damage and personal injury caused by accident.