

Menzi Muck A20

Menzi Muck A40



**menzi**  
**muck**

# The Mini Allterrain Excavator Menzi Muck A20 with 2000 kg.

## Engine

Kubota Diesel engine  
3-cylinder, water cooled  
Displacement 1123 ccm  
Output max. 24 PS (17.6 kW)  
governed to 21 PS (15.8 kW) @ 2400 rpm

## Hydraulic system

3-circuit-system  
Total capacity 48 l/min.  
Auxiliary hydraulic connection  
Working pressure 180 bar

## Swing

Hydro engine with planetary gear  
Multi-disc brake with brake pressure valve  
Slewing speed 9 rpm

## Electrical equipment

12 volts  
Alternator 1.0 kW  
Battery 60 Ah

## Measurements and dimensions

Weight	2'000 kg
Excavation height	3'900 mm
Excavation depth	2'600 mm
Discharge height	2'900 mm
Jib Range	4'600 mm
Transport width	960 mm
Transport height	2'500 mm
Dipper length	500 mm
Smallest swivelling radius	1'750 mm

## Traction

Hydrostatic wheel hub drive  
Speed up to 2.6 km/h  
Multi-disc brake  
Mechanical uncoupling of traction

## Forces

Ripping force 18.kN  
Breakout force 11 kN

## Standard equipment

Protective roof ROPS-tested  
Armrests with control lever  
Euro-Control  
Hydr. telescope dipper 500 mm  
Mec. telescope feet (3 positions)  
Working headlights  
Hydraulic chassis control cpl.  
Swivelable arm

## Options

Cab with heating  
Customer paint colour

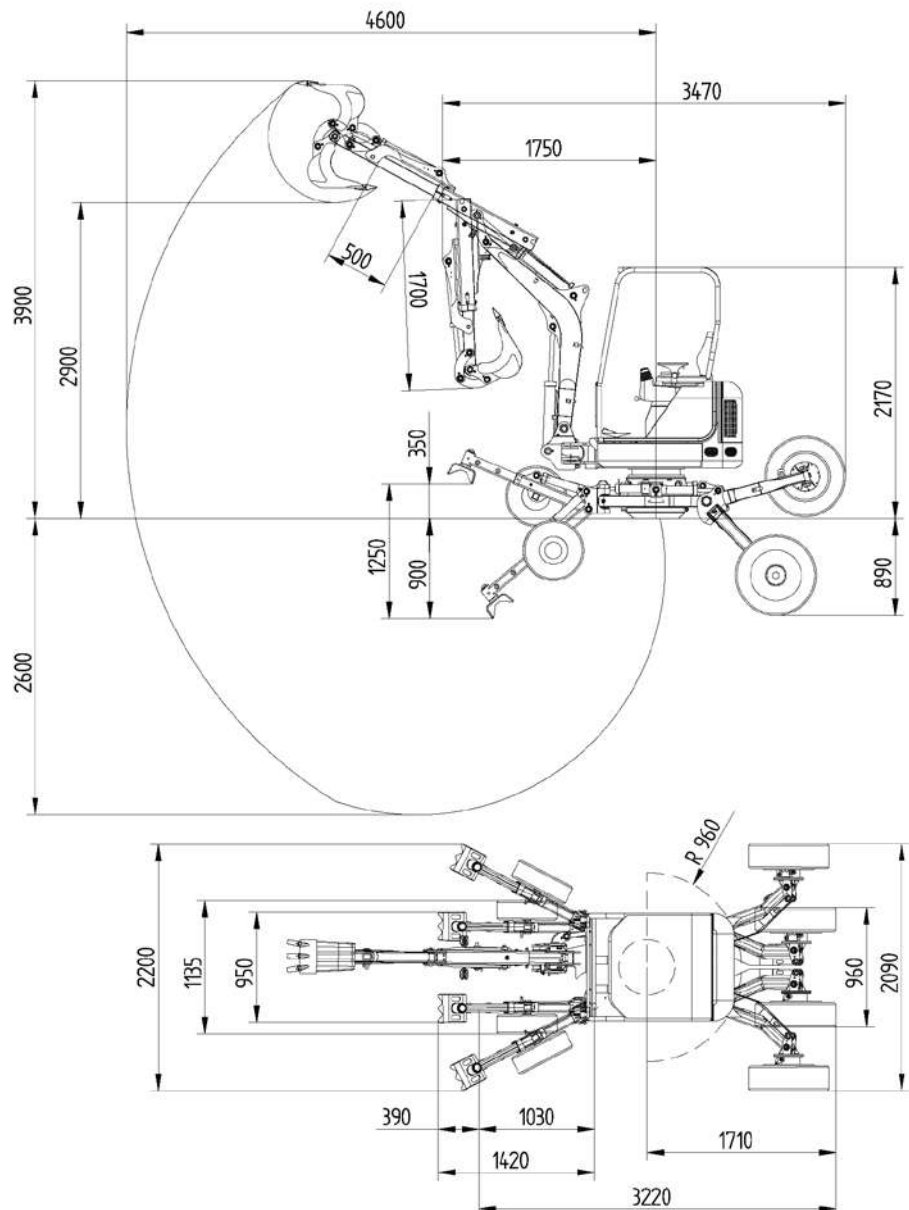

# The Mini Allterrain Excavator Menzi Muck A40 with 4500 kg.

## Engine

Turbo-Diesel engine Kubota V2607  
4-cylindre, water cooled  
Displacement 2615 ccm  
max. output 67 PS (49 kW)

## Hydraulic system

1 Regulated power axial piston pump 90 l / min.  
1 gear pump 43 l/min.  
Capacity 140 l/min.  
Working pressure 220 bar  
1 auxiliary hydr. connection on the boom 65 l/min.  
2. auxiliary hydr. connection  
3. hydr. circuit (hydr. quick changer)

## Swing

Hydro engine with planetary gear  
Multi-disc brake with brake pressure valve  
Slewing speed 10 min<sup>-1</sup>  
Slewing force 12 kN

## Elektrical system

12 volts  
Alternator 1.0 kW  
Battery 60 Ah

## Measurements and dimensions

Weight	4'500 kg
Excavation height	5'850 mm
Excavation depth	3'370 mm
Jib Range	6'023 mm
Transport width	1'400 mm
Transport height	2'550 mm
Dipper length	900 mm
Smallest swivelling radius	2'160 mm

## Traction

Hydrostatic 2-stage wheel hub drive  
1. stage up to 2.3 km/h  
2. stage up to 4.6 km/h  
Multi-disc brake  
Mechanical uncoupling of traction

## Forces

Ripping force 31 kN  
Breakout force 23 kN

## Standard equipment

Cab with heating  
Protective roof ROPS-tested  
Armrests with control lever  
Euro-Control  
Mec. telescope feet (3 positions)  
Working headlights  
Hydraulic chassis control cpl.

## Options

Costumer paint colour

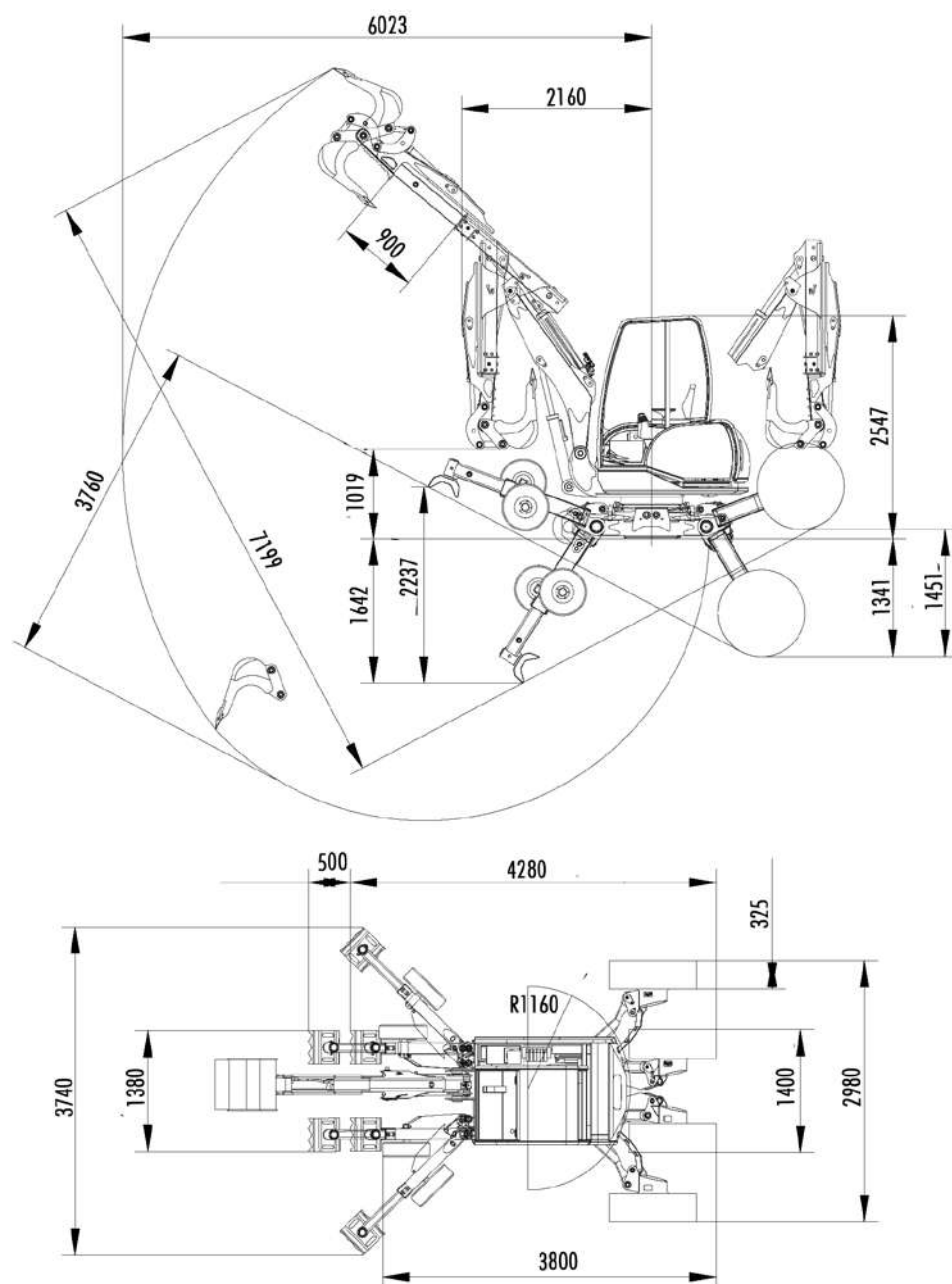

# Accessories

Menzi Muck AG is convinced that the quality of the accessories is also important. All buckets, quick changers and universal grabs are of our own design and manufacture.

The following accessories are available for the mini-allterrain mobile excavators Menzi Muck A20 and A40:

- Standard Bucket 300 mm
- Standard Bucket 400 mm
- Standard Bucket 500 mm
- Standard Bucket 600 mm
- Hydraulic Grading Bucket
- Rigid Grading Bucket
- Powertilt Swivel Head (BG 06)
- Mecanical Quick Changer SWM-010
- Hydraulic Hammer
- Universal Grab UG-04

