

Hydraulic Mining Excavator | RH 200

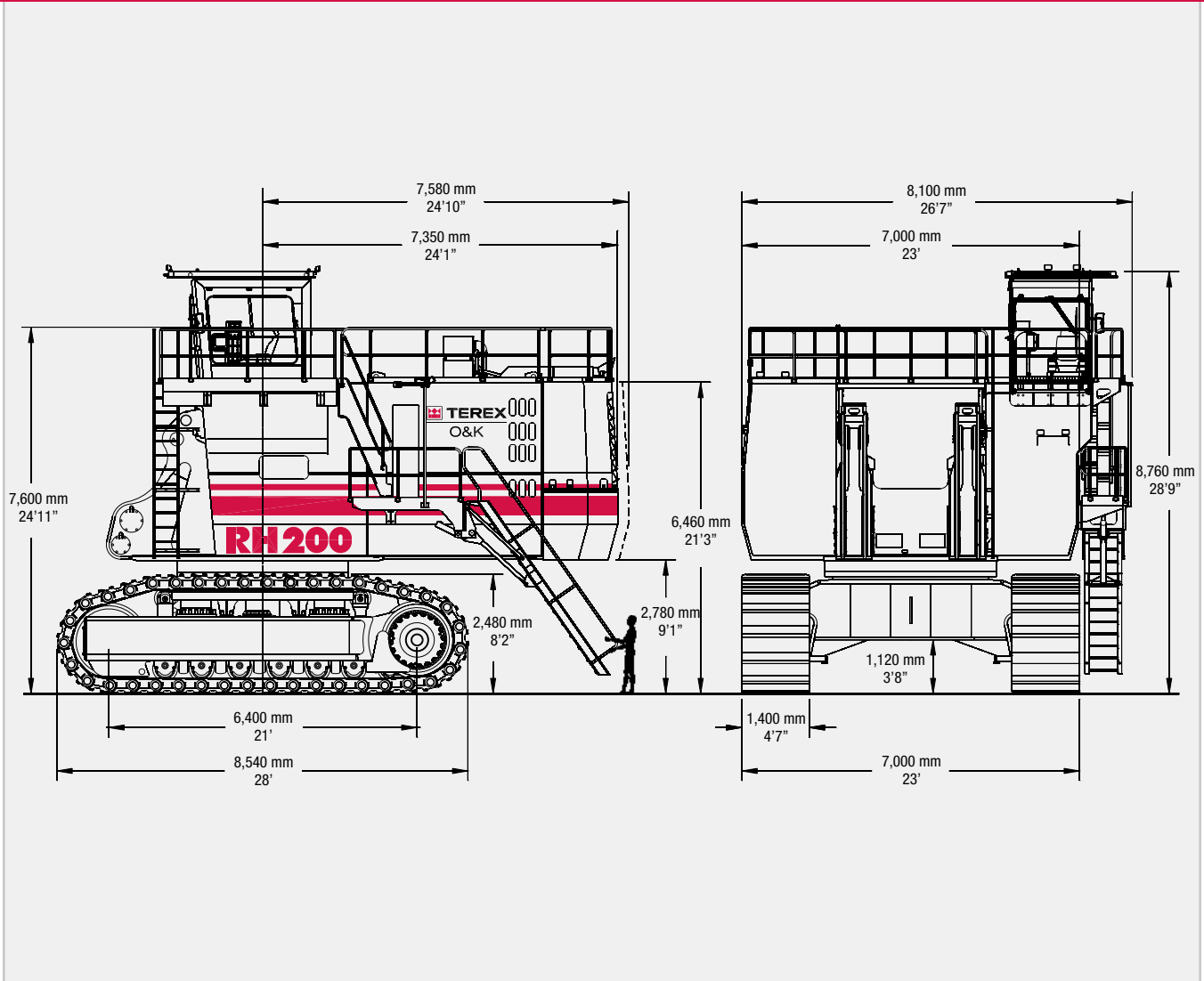

RH 200

General Data:

Operating weight		
Face Shovel	525 t	579 sht
Backhoe	534 t	589 sht
Engine output		
SAE J 1995	1,880 kW	2,520 HP
Standard bucket capacity		
Face Shovel (SAE 2:1)	26.0 m ³	34.0 yd ³
Backhoe (SAE 1:1)	28.0 m ³	36.6 yd ³

Features:

- TriPower shovel attachment
- Independent oil cooling system
- Spacious walk-through machine house
- 5-circuit-hydraulic system
- Electronic-hydraulic servo control
- Board Control System (BCS)
- Torque control in closed-loop swing circuit
- Automatic central lubrication system
- Xenon working light

Operating Weight

Shovel

Standard track pads	1,400 mm (4'7")
Operating weight	525,000 kg (1,157,420 lb)
Ground Pressure	25.7 N/cm ² (37.3 psi)
Further track pads on request	

Backhoe

Standard track pads	1,400 mm (4'7")
Operating weight	534,000 kg (1,177,260 lb)
Ground Pressure	26.2 N/cm ² (38.0 psi)
Further track pads on request	

Electrical System (diesel drive)

System voltage	24V
Batteries	6 x 244 Ah - 12 V each in series/parallel installation 732 Ah - 24 V in total
Alternators	2 x 175 A each
Working spot lights	8 x high brightness Xenon lights
<ul style="list-style-type: none"> Battery isolation relays Emergency stop switches accessible from ground level, in engine module and in operator's cab 	

Hydraulic Oil Cooling

Oil flow of cooling pumps	
Diesel version	4 x 488 l/min (4 x 129 US gal/min)
Electric version	4 x 487 l/min (4 x 129 US gal/min)
Diameter of fans	4 x 1,170 mm (4 x 46")
<ul style="list-style-type: none"> Cooling system is fully independent of all main circuits, i.e. controlled cooling capacity is available whenever engine is running Gear type cooling pumps supplying high volume low pressure oil to fans and aluminium coolers Fan speed and flow of oil to the coolers are thermostatically controlled Extremely high cooling efficiency to ensure optimum oil temperature 	

Electric Motor (optional)

Type	Squirrel cage induction motor
Output	1,600 kW
Voltage	6.6 kV ± 10 % (other on request)
Rated current I _N	166 A
Frequency	50 Hz (60 Hz optional)
Revolutions	1,500 min ⁻¹ (1,800 min ⁻¹ optional)
Starting current	350% of I _N
<ul style="list-style-type: none"> Custom-made electric motor with increased gap between rotor and stator to withstand severe mining conditions Power limit control by Pump Management System 	

Diesel Engines

Engine features

- Hydraulically driven radiator fan with electronically controlled fan speed
- Microprocessed engine control
- Automatic rev. reduction
- Heavy duty air-filters, STRATA 1 with automatic dust evacuation
- Two-stage fuel filter incl. water separator
- Additional high capacity water separator
- Pre-lube starting system
- Eliminator with centrifuge for engine oil filtration

Version 1 - Cummins K 1500-E

Make and model	2 x Cummins K 1500-E
Total rated net power ISO 3046/1	1,880 kW (2,520 HP) 1,800 min ⁻¹
Total rated net power SAE J1349	1,880 kW (2,520 HP) 1,800 min ⁻¹
Total rated gross power SAE J1995	1,880 kW (2,520 HP) 1,800 min ⁻¹
No. of cylinders (each engine)	12
Bore	159 mm (6.25 in)
Stroke	159 mm (6.25 in)
Displacement	37.8 l (2,300 in ³)
Aspiration	Turbocharged and aftercooled
Max. altitude without deration	2,438 m (8,000 ft) a.s.l.
Emission certification	US EPA Tier 2
Fuel tank capacity	10,700 l (2,820 US gal)

Version 2 - Cummins KTTA 38 C (optional for high altitudes)

Make and model	2 x Cummins KTTA 38 C
Total rated net power ISO 3046/1	1,680 kW (2,250 HP) 1,800 min ⁻¹
Total rated net power SAE J1349	1,680 kW (2,250 HP) 1,800 min ⁻¹
Total rated gross power SAE J1995	1,680 kW (2,250 HP) 1,800 min ⁻¹
No. of cylinders (each engine)	12
Bore	159 mm (6.25 in)
Stroke	159 mm (6.25 in)
Displacement	37.8 l (2,300 in ³)
Aspiration	Turbocharged and aftercooled
Max. altitude without deration	4,500 m (14,800 ft) a.s.l.
Emission certification	not available

Hydraulic System with PMS

Main pumps (Diesel and electric version)	4 x variable flow axial piston pumps
Max. oil flow	Diesel version 4 x 912 l/min (4 x 241 US gal/min) Electric version 4 x 924 l/min (4 x 244 US gal/min)
Max. pressure, attachment	30 MPa = 300 bar (4,350 psi)
Max. pressure, travel	36 MPa = 360 bar (5,220 psi)
Swing pumps	Diesel version 4 x reversible swash plate pumps Electric version 3 x reversible swash plate pumps
Max. oil flow	Diesel version 4 x 351 l/min (4 x 93 US gal/min) Electric version 3 x 487 l/min (3 x 129 US gal/min)
Max. pressure, swing circuit	35 MPa = 350 bar (5,080 psi)
Total volume of hydraulic oil	approx. 8,400 l (2,220 US gal)
Hydraulic tank capacity	approx. 6,100 l (1,610 US gal)

- Pump Managing System (PMS) contains:
 - Electronic load limit control
 - Flow on demand from main pumps depending on joystick position
 - Automatic regulation of main pumps to zero flow without demand
 - Automatic rpm reduction of engine speed during working breaks
 - Reduced oil flow of main pumps at high hydraulic oil temperature or at high engine temperature
- Pressure cut-off for main pumps
- Cooling of pump transmission gear oil
- Filters:
 - Full-flow high-pressure filters (100 µm) for the main pumps, installed directly behind each pump
 - High pressure filters (100 µm) for the closed swing circuit
 - Full-flow filters (10 µm) for the complete return circuit
 - Pressure filters (40 µm and 6 µm) for servo circuit
 - Pressure filters (40 µm) for the feed pumps of the closed swing circuit
 - Transmission oil filters (40 µm)

Undercarriage

Travel speeds (2 stages)	1 st stage	Max. 2.3 km/h (1.44 mph)
	2 nd stage	Max. 1.6 km/h (0.99 mph)
Max. tractive force	2,520 kN (257 t = 566,320 lb)	
Gradability of travel drives	Max. 50 %	
Track pads (each side)	39	
Bottom rollers (each side)	6	
Support rollers (each side)	2 plus a skid plate in between	
Travel drives (each side)	1 planetary transmission with 2 two-stage axial piston motors	
Parking brakes	Wet multiple disc brake, spring applied / hydraulically released	
<ul style="list-style-type: none"> • Cast double-grouser combined pad-links with bushings connected by hardened full floating pins • All running surfaces of sprockets, idlers, rollers and pad links as well as teeth contact areas of sprocket and pad links are hardened • Fully hydraulic self-adjusting track tensioning system with membrane accumulator • Automatic hydraulic retarder valve to prevent over-speed on downhill travel • Acoustic travel alarm 		

Operator's Cab

Operator's eye level	approx. 7.6 m (24'11")	
Internal dimensions of cab	Length	2,200 mm (7'3")
	Width	1,600 mm (5'3")
	Height	2,150 mm (7'1")
<ul style="list-style-type: none"> • Pneumatically cushioned and multi-adjustable comfort seat with lumbar support, seat heating, safety belt, head and arm rests • Switch in seat cushion to neutralize automatically the hydraulic controls when operator leaves the seat • Joystick controls integrated in independently adjustable seat consoles • Fold-away auxiliary seat with safety belt • FOPS (rock guard; approved acc. to DIN ISO 3449) integrated into cab structure • All-round safety glass, armoured windshield and sliding side window • Windshield with parallel intermittent wiper/washer • Roller blind at windshield • Robust instrument panel incl. large colored BCS screen with transfective technology • Terex® O&K Board Control System (BCS) electronic monitoring and data logging system for vital signs and service data of engines, hydraulic and lubrication system • Machine access via retractable boarding ladder, hydraulically operated • Emergency ladder mounted at A-frame 		

Attachments

- Booms and sticks are torsion resistant, welded box design of high tensile steel with massive steel castings at pivot areas
- Welding procedures allow for internal counter-welding (double prep weld) wherever possible
- Booms and sticks are stress relieved after welding
- Inspection hole in booms
- Catwalks with rails at booms
- "Pressure-free lowering" of boom (FS and BH) and stick (FS) by means of a float valve
- Shovel attachment with Terex® O&K patented TriPower kinematics ensuring the following main features:
 - Horizontal automatic constant-angle bucket guidance
 - Vertical automatic constant-angle bucket guidance
 - Automatic roll-back limiter to prevent material spillage
 - Kinematic assistance to hydraulic forces
 - Constant boom momentum throughout the whole lift arc
 - Crowd force assistance
- All buckets (FS and BH) are equipped with a universal wear wear package suitable for all standard applications, which consists of:
 - Special liner material covering main wear areas inside and outside of bucket
 - Lip shrouds between teeth
 - Wing shrouds on side walls
 - Heel shrouds at bottom edges
- Special wear packages for highly abrasive materials on request

Swing System

Swing drives	4 compact planetary transmissions with axial piston motors	
Parking brakes	Wet multiple disc brake, spring loaded / hydraulically released	
Max. swing speed	Diesel version	3.9 rpm
	Electric version	4.1 rpm
Swing ring	Triple race roller bearing with sealed internal gearing	
<ul style="list-style-type: none"> • Closed-loop swing circuit with torque control • Hydraulic braking of the swing motion by counteracting control • All race ways of swing ring as well as grease bath for internal gearing supplied by automatic central lubrication system 		

Automatic Lubrication System

Capacity of grease container	1,000 l (264 US gal)
<ul style="list-style-type: none"> • Dual-circuit system with hydraulically driven heavy-duty pump and electronic time relay control to adjust the pause/lube times • Connected to the lubrication system are the swing roller bearing with internal gearing and all pivot points of attachment, bucket and cylinders • System failures displayed by Board Control System • Grease filters (200 µm) between service station and container as well as directly behind grease pump 	

Retractable Service Station

Retractable service station installed underneath the engine module and easily accessible from ground.

Equipped with:

- Quick couplings for:
 - Diesel fuel
 - Engine coolant - left/right
 - Pump transmission gear oil - left/right
 - Engine oil (oil pan) - left/right
 - Engine oil (additional tank - optional) - left/right
 - Hydraulic oil tank
 - Grease container
- CAT jump start socket
- Indicator lights for "fuel tanks left / right full" and "grease container full"

TriPower Face Shovel Attachment (FS)

Working Diagram - Boom 8.0 m (26'2") - Stick 5.1 m (16'9")

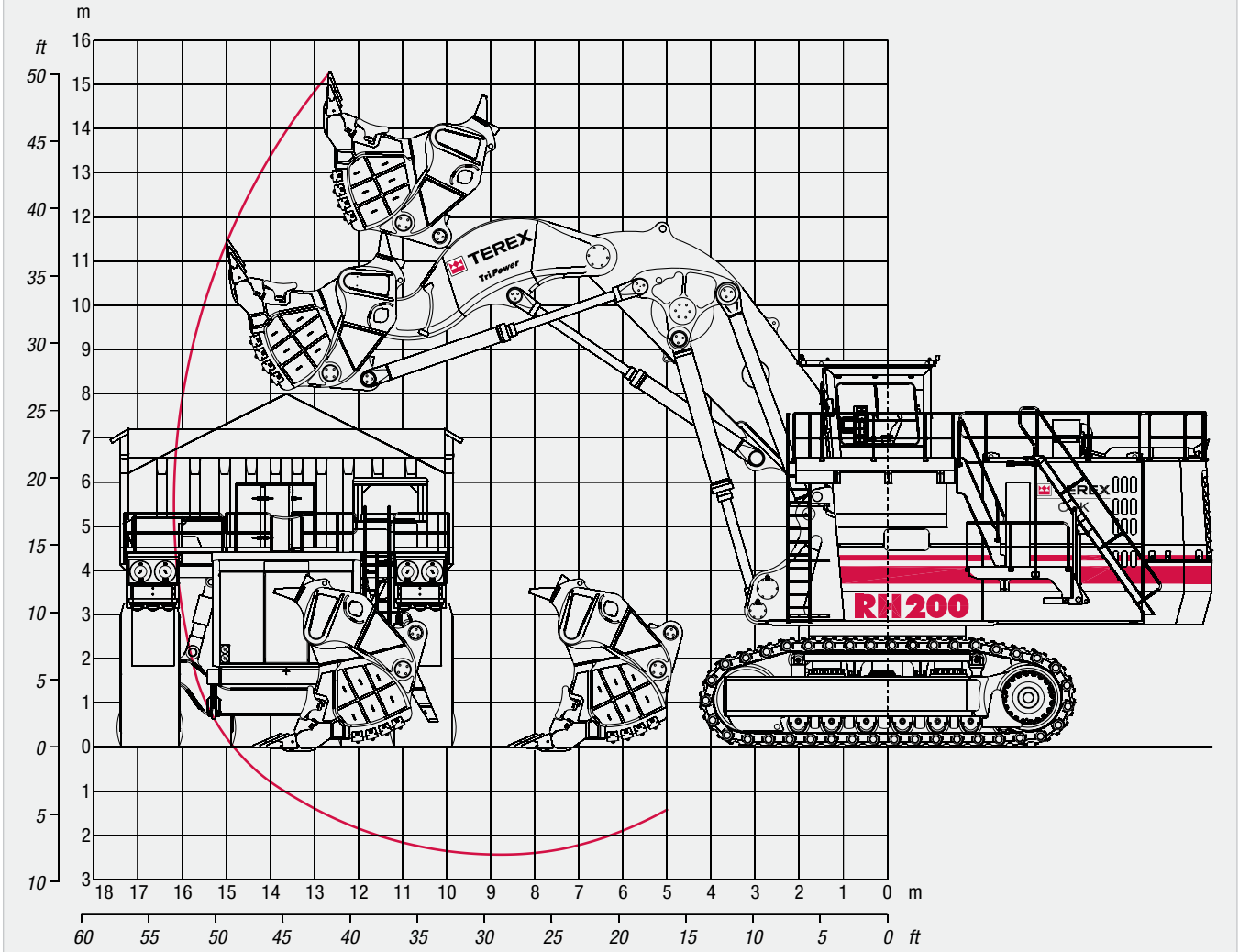

Working Range

Max. digging height	15.3 m	50'2"
Max. digging reach	16.2 m	53'2"
Max. digging depth	2.4 m	7'10"
Max. dumping height	11.8 m	38'9"
Crowd distance on level	5.5 m	19'

Digging Forces

Max. crowd force	1,890 kN	424,740 lb
Max. crowd force at ground level	1,650 kN	370,800 lb
Max. breakout force	1,500 kN	337,100 lb

Face Shovels

Type	Heavy rock shovel	Standard rock shovel
Tooth system	ESCO Posilok system S 130	ESCO Posilok system S 130
Capacity SAE/PCSA 1:1	24.5 m ³ (32.0 yd ³)	30.5 m ³ (39.9 yd ³)
Capacity SAE/CECE 2:1	21.0 m³ (27.5 yd³)	26.0 m³ (34.0 yd³)
Total width	4,800 mm (15'9")	4,800 mm (15'9")
Inner width	4,300 mm (14'1")	4,300 mm (14'1")
Opening width	2,500 mm (8'2")	2,500 mm (8'2")
No. of teeth	6	6
Weight incl. universal wear kit	42,400 kg (93,480 lb)	42,900 kg (94,580 lb)
Max. material density (loose)	2.2 t/m ³ (3,710 lb/yd ³)	1.8 t/m ³ (3,030 lb/yd ³)

Backhoe Attachment (BH)

Working Diagram - Boom 10.5 m (34'5") - Stick 5.5 m (18'1")

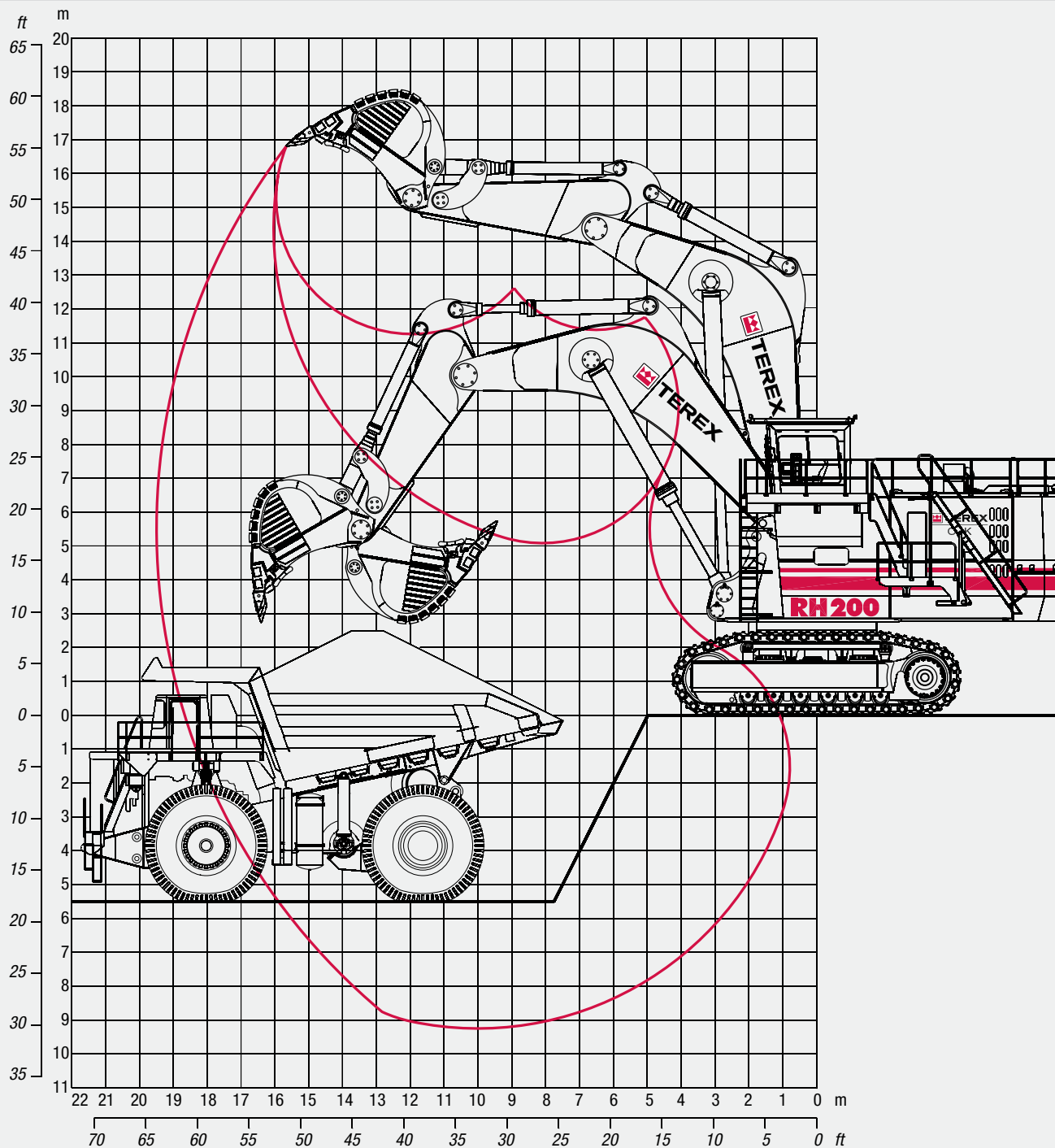

Backhoes

Type	Standard rock bucket	Other buckets on request
Tooth system	ESCO size 110	
Capacity SAE 1:1	28.0 m³ (36.6 yd³)	
Capacity CECE 2:1	24.6 m ³ (32.2 yd ³)	
Capacity struck	21.2 m ³ (27.7 yd ³)	
Total width	4,440 mm (14'7")	
Inner width	4,040 mm (13'3")	
No. of teeth	6	
Weight incl. universal wear kit	32,000 kg (70,550 lb)	
Max. material density (loose)	1.8 t/m ³ (3,030 lb/yd ³)	

Working Range

Max. digging depth	9.2 m	30'2"
Max. digging reach	19.5 m	64'
Max. digging height	16.8 m	55'1"

Digging Forces

Max. crowd force	1,200 kN	269,680 lb
Max. breakout force	1,200 kN	269,680 lb

General Packing List

Crawler side frame (2 units)

Width 2,140 mm (7'0") Gross weight 44,100 kg (97,220 lb)

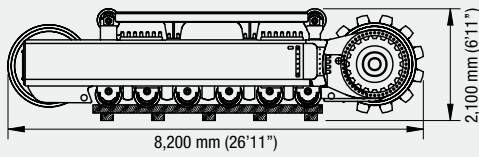

6 tracks consisting of 13 pad links; each:

Width 1,400 mm (4'7") Gross weight (each) 10,700 kg (23,590 lb)

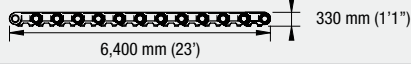

Undercarriage centre frame with swing roller bearing

Width 3,800 mm (12'6") Gross weight 42,300 kg (93,250 lb)

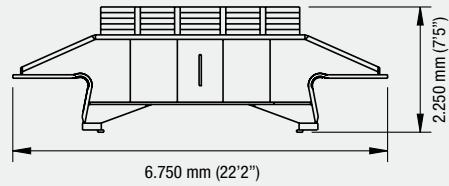

Superstructure centre frame

Width 3,600 mm (11'10") Gross weight 60,000 kg (132,280 lb)

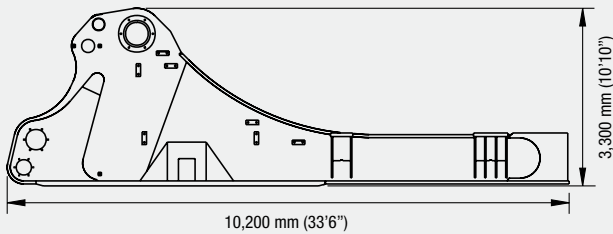

Engine module with diesel engines

Width 7,000 mm (23') Gross weight 42,640 kg (94,000 lb)

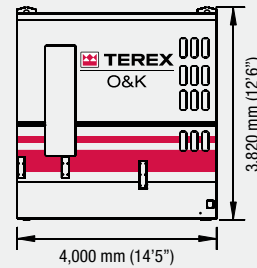

Cab pedestal module

Width 2,500 mm (8'2") Gross weight 6,500 kg (14,330 lb)

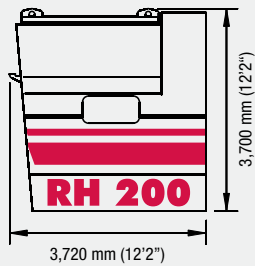

Oil cooler module

Width 2,000 mm (6'7") Gross weight 9,750 kg (21,490 lb)

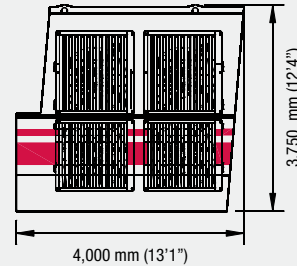

Crate with cabin and FOPS

Width 2,600 mm (8'7") Gross weight 3,500 kg (7,720 lb)

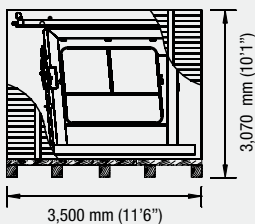

Counterweights

	Width	Gross weight
Lower part	7,000 (23')	36,900 kg (81,350 lb)
Upper part	7,000 (23')	19,300 kg (42,550 lb)

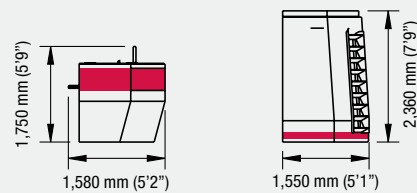

Crates

Content	Length	Width	Height	Gross weight
2 Radiators with fan; 2 crates each:	2,700 mm (8'10")	2,100 mm (6'11")	720 mm (2'4")	1,230 kg (2,710 lb)
Four swing gear	1,350 mm (4'5")	1,350 mm (4'5")	1,900 mm (6'3")	5,340 kg (11,770 lb)
Swing ring cover	2,200 mm (7'3")	1,300 mm (4'3")	1,030 mm (3'5")	390 kg (860 lb)
Swing ring bolts, access ladder, etc.	3,300 mm (10'10")	1,600 mm (5'3")	1,260 mm (4'2")	3,700 kg (8,160 lb)
Catwalks and other parts	4,960 mm (16'3")	1,900 mm (6'3")	1,740 mm (5'9")	3,500 kg (7,720 lb)
Grease container with pump	1,700 mm (5'7")	1,300 mm (4'3")	2,050 mm (6'9")	1,470 kg (3,240 lb)
Barrels (hydraulic oil; grease)	3,700 mm (12'2")	1,350 mm (4'5")	1,350 mm (4'5")	3,150 kg (6,940 lb)

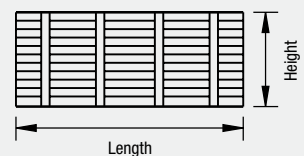

Above values are approximate. Details may vary depending on scope of supply and destination. Exact data subject to selected machine configuration and final packing list.

TriPower Shovel Attachment

Boom with main valve block, TriPower linkages and rods

Width 3,050 mm (10') Gross weight 46,800 kg (103,180 lb)

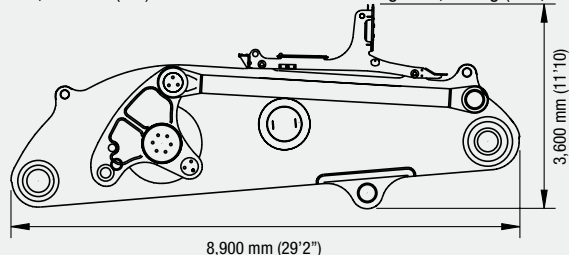

Stick

Width 2,800 mm (9'2") Gross weight 17,000 kg (37,480 lb)

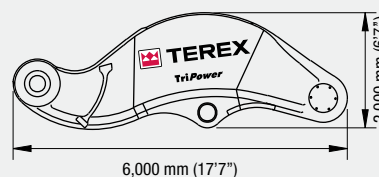

Face shovel incl. pin for stick

Capacity (2:1) Width Gross weight
26.0 m³ (34.0 yd³) 4,800 mm (15'9") 43,900 kg (96,780 lb)

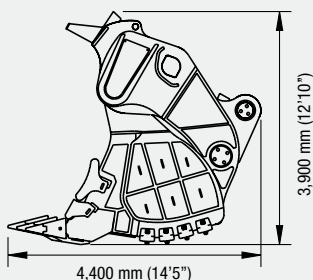

Crates with catwalks, railings and other parts

Length-mm (ft.in)	Width-mm (ft.in)	Height-mm (ft.in)	Gross weight-kg (lb)
3,900 (12'10")	1,900 (6'3")	1,600 (5'3")	3,300 (7,280)

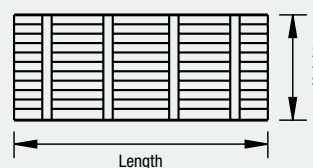

Bundle with 2 boom cylinders

Width 1,200 mm (3'11") Gross weight 7,100 kg (15,650 lb)

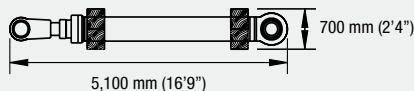

2 Bundles with 2 stick cylinders and 2 bucket cylinders, each:

Width 1,200 mm (3'11") Gross weight 5,200 kg (11,460 lb)

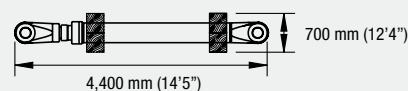

Backhoe Attachment

Monoboom without main valve block

Width 5,000 mm (16'5") Gross weight 46,000 kg (101,410 lb)

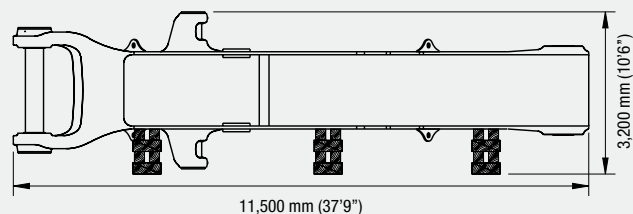

Stick with linkage and bucket cylinders

Width 2,300 mm (7'7") Gross weight 27,300 kg (60,190 lb)

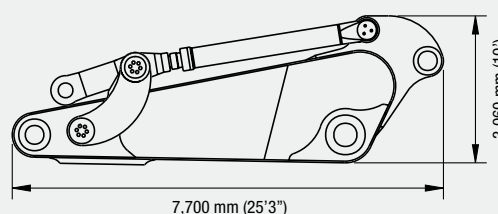

Backhoe bucket incl. pins for stick and linkage

Capacity (2:1) Width Gross weight
28 m³ (36.6 yd³) 4,440 mm (14'7") 34,100 kg (75,180 lb)

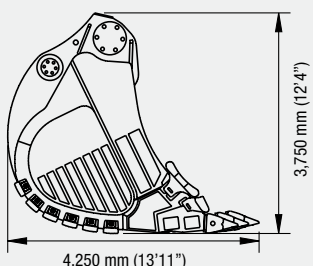

Crates with main valve block, catwalks, railings and other parts

Length-mm (ft.in)	Width-mm (ft.in)	Height-mm (ft.in)	Gross weight-kg (lb)
4,500 (14'9")	2,150 (7'1")	1,700 (5'7")	5,000 (11,020)
3,900 (12'10")	1,900 (6'3")	1,600 (5'3")	3,100 (6,830)

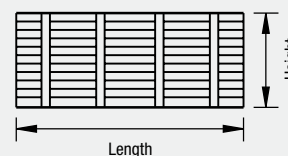

2 pallets with boom cylinders, each:

Width 800 mm (2'7") Gross weight 7,180 kg (15,830 lb)

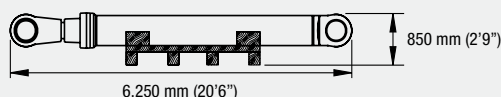

2 pallets with stick cylinders, each:

Width 800 mm (2'7") Gross weight 4,200 kg (9,260 lb)

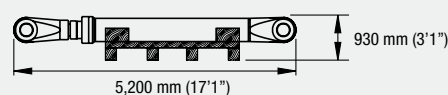

Above values are approximate. Details may vary depending on scope of supply and destination. Exact data subject to selected machine configuration and final packing list.

Component accessibility on superstructure

- | | | | |
|---|-------------------|-----------------------------------|---------------------|
| 1. Diesel engines | 4. Oil coolers | 7. Rotary distributor | 10. Operator's seat |
| 2. Gearboxes with hydraulic pumps | 5. Hydraulic tank | 8. Travel valves | 11. BCS tower |
| 3. Engine radiators with hydraulically driven fan | 6. Swing drives | 9. Switch cabinet and battery box | 12. Auxilliary seat |

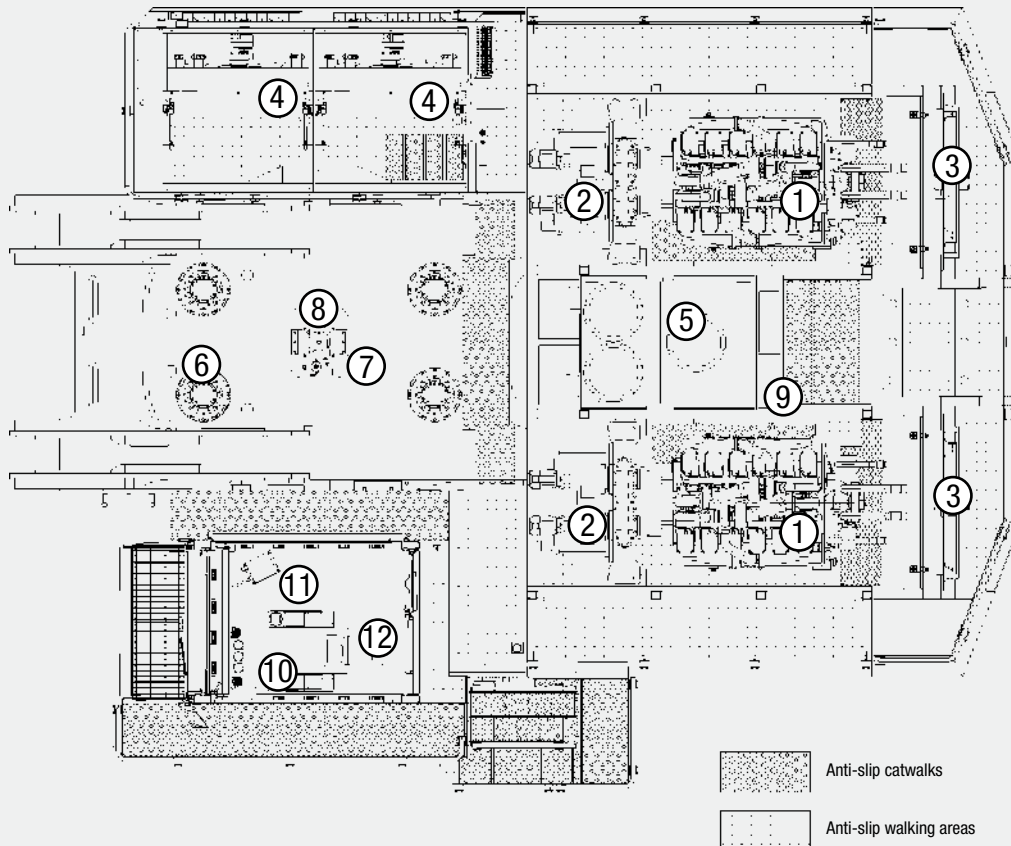

Optional Equipment

General

- Export crating
- Finishing as per enduser's corporate colours
- Customizing of logos as per customer's specification

Superstructure

- Hydraulic service crane on superstructure with auxilliary engine
- Mesabi radiators instead of standard radiators
- Oil change interval extension for engine oil up to 1000 hrs
- Engine oil burn system
- Folding access stairway, stairway angle approx. 45°
- Round container with a standard 200 l grease barrel (instead of 1000 l grease container)
- Lubricated pinion for greasing of internal gearing of swing ring
- Various cold weather packages
- Further optional equipment on request

Cab

- Various heating and airconditioning systems
- Roller blinds at all windows
- Outside mounted sun shields
- Rear windscreen wiper
- Additional instrumentation

Undercarriage

- Track pad width 1,600 mm or 1,800 mm
- Automatic lubrication of rollers by central lube system
- Cover plate under carbody (belly plate)

Attachment

- Guards for shovel cylinders of FS-attachment
- Xenon lighting on boom
- Special wear packages

The technical specifications mentioned in this data sheet may vary according to the specific equipment/options installed.

Effective Date: April 2008. Product specifications and prices are subject to change without notice or obligation. The photographs and/or drawings in this brochure are for illustrative purposes only. Refer to the appropriate Operator's Manual for instructions on the proper use of this equipment. Failure to follow the appropriate Operator's Manual when using our equipment or to otherwise act irresponsibly may result in serious injury or death. The only warranty applicable to our equipment is the standard written warranty applicable to the particular product and sale and Terex makes no other warranty, express or implied. Products and services listed may be trademarks, service marks or trade-names of Terex Corporation and/or its subsidiaries in the USA and other countries and all rights are reserved. Terex is a registered trademark of Terex Corporation in the USA and many other countries. Copyright 2008 Terex Corporation. M 123.2 e / PDF 0408

Terex GmbH
 Karl-Funke-Str. 36, D-44149 Dortmund, Germany
 Tel +49 (0) 231 922 3 Fax +49 (0) 231 922 5800
 info@terex-ok.com
 www.terex-ok.com