

MODEL AND FEATURES	OPTIONALS INCLUDED
<b>CAST 23T</b> Engine Kubota D902 Speed 10-12 Km/h Hydrostatic transmission 4WD Electric differential lock Water cooling 5- function Joystick Metal hood and rear hood	"Universal" coupling plate 12V power outlet: standard Ergonomic seat with belts: standard Rops/fops protection: standard Telescopic boom: standard Tractor wheels: 23x8.50-12 Weight: 1200 Kg
<b>CAST 28T</b> Engine Kubota D1105 Speed 12 Km/h Hydrostatic transmission 4WD Electric differential lock Water cooling 5- function Joystick Metal hood and rear hood	"Universal" coupling plate 12V power outlet Ergonomic seat with belts Rops/fops protection Telescopic boom Tractor wheels 23x10.50-12 Weight 1250 Kg
<b>CAST 30T</b> Engine Kubota D1105 Speed 14 Km/h Hydrostatic transmission 4WD Electric differential lock Water cooling 5- function Joystick Metal hood and rear hood Self levelling	<b>CAST 30T CARBON</b> LED working lights ( 2 on the front+1 on the back) "Universal" coupling plate 12 V power outlet + front aux electric outlet (165W) Ergonomic seat with belts Rops/fops protection Telescopic boom Tractor wheels 26x12.00-12 Weight 1270 Kg
<b>CAST 33T</b> Engine Kubota D1305 Speed 16 Km/h Hydrostatic transmission 4WD Electric differential lock Water cooling 5- function Joystick Metal hood and rear hood Self levelling	LED working lights ( 2 on the front+1 on the back) "Universal" coupling plate 12 V power outlet + front aux electric outlet (165W) Ergonomic seat with belts Rops/fops protection Telescopic boom Tractor wheels 26x12.00-12 Weight 1300 Kg
<b>CAST 33TLX Single Speed</b> Engine Kubota D1305 Speed 12 Km/h @ 26x12-12 (Poclain) Hydrostatic transmission 4WD Electric differential lock Water cooling 11- function Joystick Metal hood and rear hood Self levelling LED working lights ( 2 on front+1 on back)	<b>CAST 33TLX CARBON Dual Speed</b> Carbon Look dashboard Ergonomic Joystick Speed 9-20 Km/h @ 26,5x14-12 (Poclain) Heated comfort seat Special finishes with sable paint New layout

## 30 SERIES

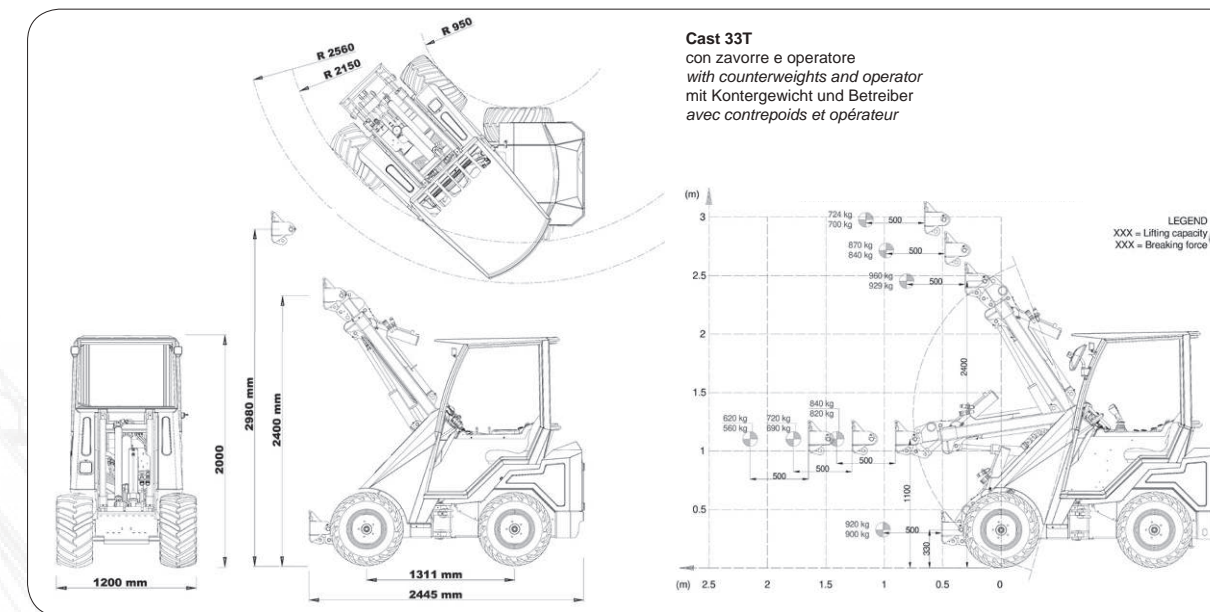

### WHEELS

SKID	TRAC MASTER	TRACTOR	TURF
23X8.50-12 23X10.50-12 26X12.00-12	8PR 300/60X12	23X8.50-12 23X10.50-12 26X12.00-12	23X8.50-12 23X10.50-12 24X13.00-12 26X12.00-12 26.5X14.00-12

### 30 SERIES MODELS

	LIFTING CAPACITY	ENGINE POWER	HYDRAULIC SYSTEM	BOOM HEIGHT
CAST 23T	850 Kg (with counterweights)	23 Hp	32 lt/min	2945 mm
CAST 28T	950 Kg (with counterweights)	25 Hp	42 lt/min	2945 mm
CAST 30T	950 Kg (with counterweights)	25 Hp	42 lt/min	2945 mm
CAST 33T	950 Kg (with counterweights)	25 Hp	46 lt/min	2980 mm
CAST 33TLX	950 Kg (with counterweights)	25 Hp	46 lt/min	2980 mm



**CASTGROUP**

CAST GROUP S.r.l. UNIPERSONALE  
 Via A. Meucci, 18  
 30035 Mirano VE Italia  
 ph. +39 041 5701827- fax +39 041 5726786  
 info@cast-group.it

PEDIA\_30 SERIES\_ENG\_05/2021

Data contained in this document is subject to change without notice and/or notification. Cast Group reserves the right to modify its products without obligation to communicators. The images in this document are only a demonstrative purpose.







30 Series is compactness. With its 2445mm in length, 1160mm in min. width and 1970mm in min. height, it is able to access the narrowest rooms and it is easily transportable.



The Carbon Line series is characterized by the "Carbon-Look" finishing of the dashboard which give the machine greater sportiness and more aggressive configuration. The latest-generation ergonomic joystick is standard on all Carbon line models.



Details make the difference.

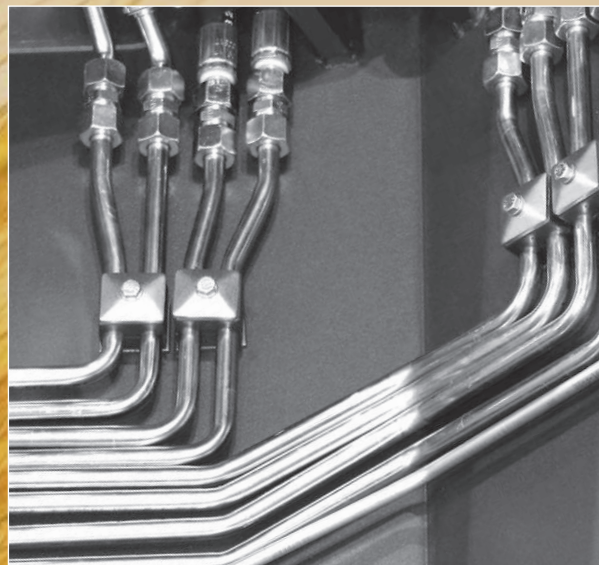

**30 SERIES**

**RPS**

RPS (Rigid Pipe System) is the hydraulic piping distribution system used on the whole 30 Series. The rigid pipes are made of the highest quality materials and guarantee an extraordinary resistance to wear and tear. They are arranged in an orderly manner and are easily accessible for maintenance.



Electronic display with warning lights indicating faults, engine, hydraulic oil gauge, and electric floating system.



Joystick 5 and 11 functions. 11-functions Joystick is standard on LX models.



Maximum speed : 12 Km/h (mod. LX ,Poclairn Single Speed). 20 Km/h (mod. LX Carbon, Poclairn Dual Speed).



Double-pump for a better performance, operating speed, comfort and fluidity of use.



Telescopic boom height up to 2980mm, the highest of its line.



Electric differential lock is standard on all models.



Series 30 Castloaders represents technology and innovation in the field of multifunctional loaders. Technical features make the difference and stand out to the advantage of improved performance, easiness of use and reduced maintenance.

The new rear hydraulic outlets are easily accessible. There is the possibility to add the hydraulic flow divider, typical of big municipal machinery, which allows to work simultaneously with front and rear equipment.

The controls of the hydraulic pumps are at hand and well arranged.

Up to 46 liters of oil are available for the functioning of hydraulic equipment, mulchers, lawnmowers, bigger tillers.

**CASTLOADERS**



A wide range of accessories is available for the models of 30 Series to meet the multiple needs in the agriculture, farming, forestry, construction and gardening sectors.



Insulated and heated cabin, for a comfortable and safe driving in all conditions.



**30 SERIES**