

CDM860.001
WHEEL LOADER

PARTS BOOK

Preface

Thank you for selecting our products.

The Parts Book is specifically for the CDM860.001 wheel loader with standard configuration, which provides relevant detailed information about all systems/assemblies/parts, including Chinese/English description, part number, specification and quantity per unit etc.

Non-standard products configured with other brand diesel engine, transmission, axles and optional parts, and modified loaders, e.g. coal loader, rock loader and high dump loader etc, can cause some changes in the systems/assemblies/parts, which are not listed in the Parts Book. Product improvement or supplier alteration might make parts different. If you have any question about the manual, please contact us or your nearest dealer.

In addition to parts description, specification and quantity, the Serial Number and Manufacture Date of specified machine should be supplied with spare parts order, so that we can deliver you correct parts in time.

Customers are sincerely requested to give us suggestions with contact information on the back cover.

Lonking Holdings Limited

May, 2010

Contents

I. Diesel Engine System	01	VIII. Service Brake System	109
1.1 Diesel engine system	01	IX. Parking Brake System	117
II. Torque Converter system	05	X. Frame System	121
2.1 Torque converter system	05	XI. Implement Assembly System	129
2.2 Torque converter and Transmission oil circuit assembly	07	XII. Cab System	133
III. Transmission System	09	XIII. Out Panel System	143
3.1 Transmission system	09	13.1 Out panel system	143
3.2 Transmission assembly	11	13.2 Hydraulic oil tank assembly	145
3.3 Torque converter assembly	15	13.3 Fuel tank assembly	149
3.4 Planet line assembly	21	XIV. Electrical System	153
3.5 Transfer case assembly	35	XV. Tool Kit	161
IV. Axle System	43	XVI. Warning Mark System	167
4.1 Axle system	43	XVII. Greasing Points Indication Layout	171
4.2 Front axle assembly	45	XVIII. Wiring Harness	172
4.3 Main reducer assembly	47		
4.4 Differential assembly	51		
4.5 Wheel-side reducer assembly	53		
4.6 Rear axle assembly	59		
4.7 Main reducer assembly	61		
4.8 Differential assembly	65		
4.9 Wheel-side reducer assembly	67		
V. Hydro-electric speed control System	73		
5.1 Hydro-electric speed control System	73		
VI. Steering Hydraulic System	75		
6.1 Steering hydraulic system	75		
6.2 Hydraulic steering gear	85		
6.3 Steering Cylinder	89		
VII. Implement Hydraulic System	93		
7.1 Implement hydraulic system	93		
7.2 Pilot control system	105		

柴油机系统 Diesel Engine system

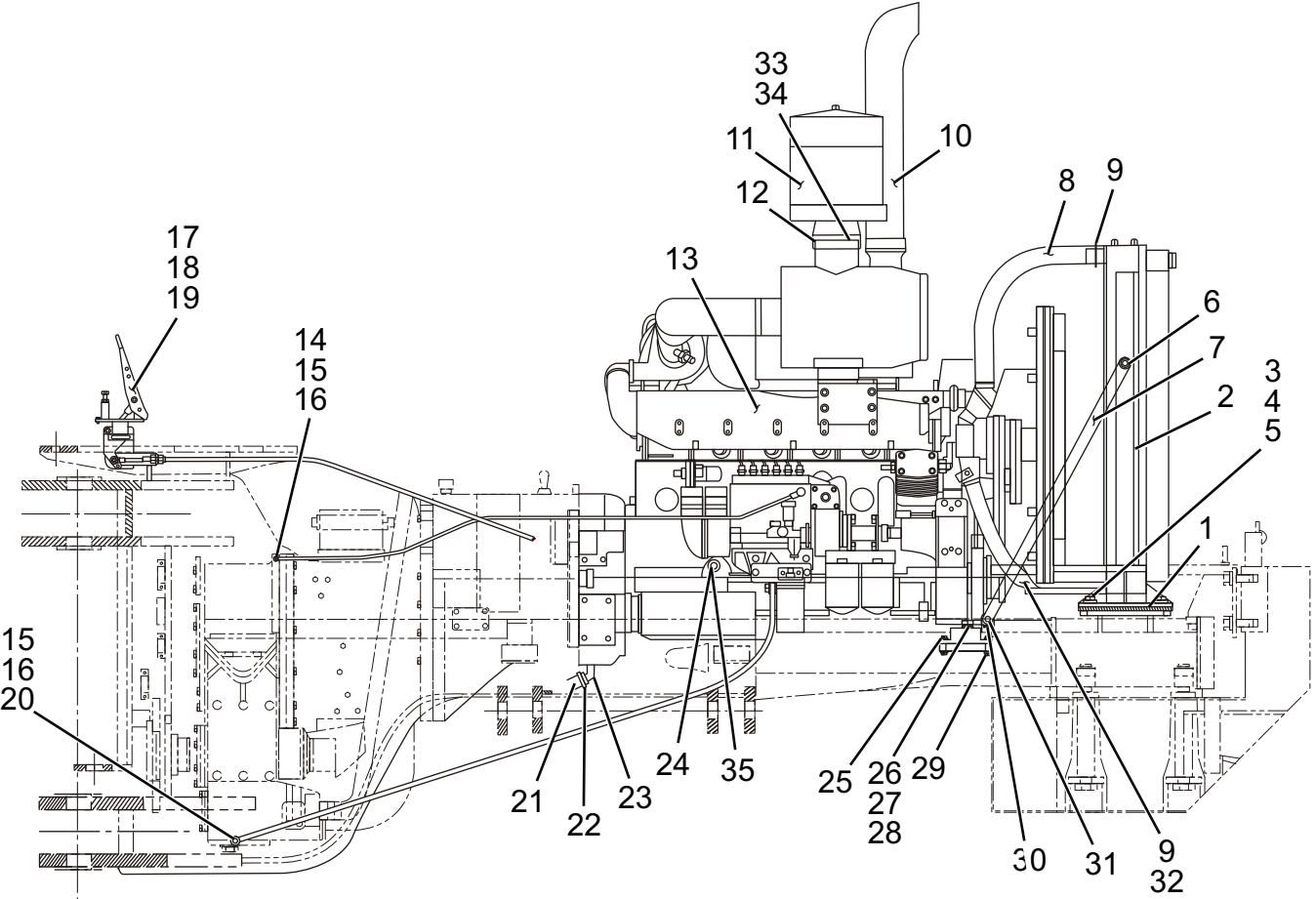

DIESEL ENGINE

Figure 01

柴油机系统 Diesel Engine system						
Item	Parts number	Chinese Description	English Description	Specification	Qty	Remarks
1	LG860.01-002	水箱胶垫	Radiator rubber pad		4	散热器带
2	CDM860.01.04	散热器总成	Radiator assembly		1	浙江银轮 S390407-01
3	GB/T5783-2000	螺栓	Bolt	M14X40	4	8.8
4	GB/T97.1-2002	垫圈	Washer	14	8	
5	GB/T93-1987	垫圈	Washer	14	8	
6	GB/T5783-2000	螺栓	Bolt	M12X30	4	8.8
7	LG860.01-003	水箱拉杆	Radiator poll rod		2	
8	CDM860.01-001	水箱进水胶管	Radiator water inlet hose		1	
9	90003989308	软管卡箍	Hose clamp		4	柴油机带
10	612600110506	消声器出气管	Muffle air outlet hose		1	柴油机带
11	LG860.01.02	空气预滤器总成	Air foreordain cleaner		1	外购 / 柴油机带
12	LG860.01.05-001	T 型抱箍	T- type anchor ear		1	
13	LG860.01.03	柴油机总成	Diesel engine assembly		1	DHD10G0046*01
14	612600080789	柴油机回油管	Fuel oil return pipe		1	柴油机带
15	90003962621	空心螺栓	Hollow bolt		2	柴油机带
16	612600080200	密封垫圈	Sealed washer		4	柴油机带
17	LG853.01.06	油门踏板总成	Throttle pedal assembly		1	
18	GB/T5783-2000	螺栓	Bolt	M6X16	3	8.8

柴油机系统 Diesel Engine system

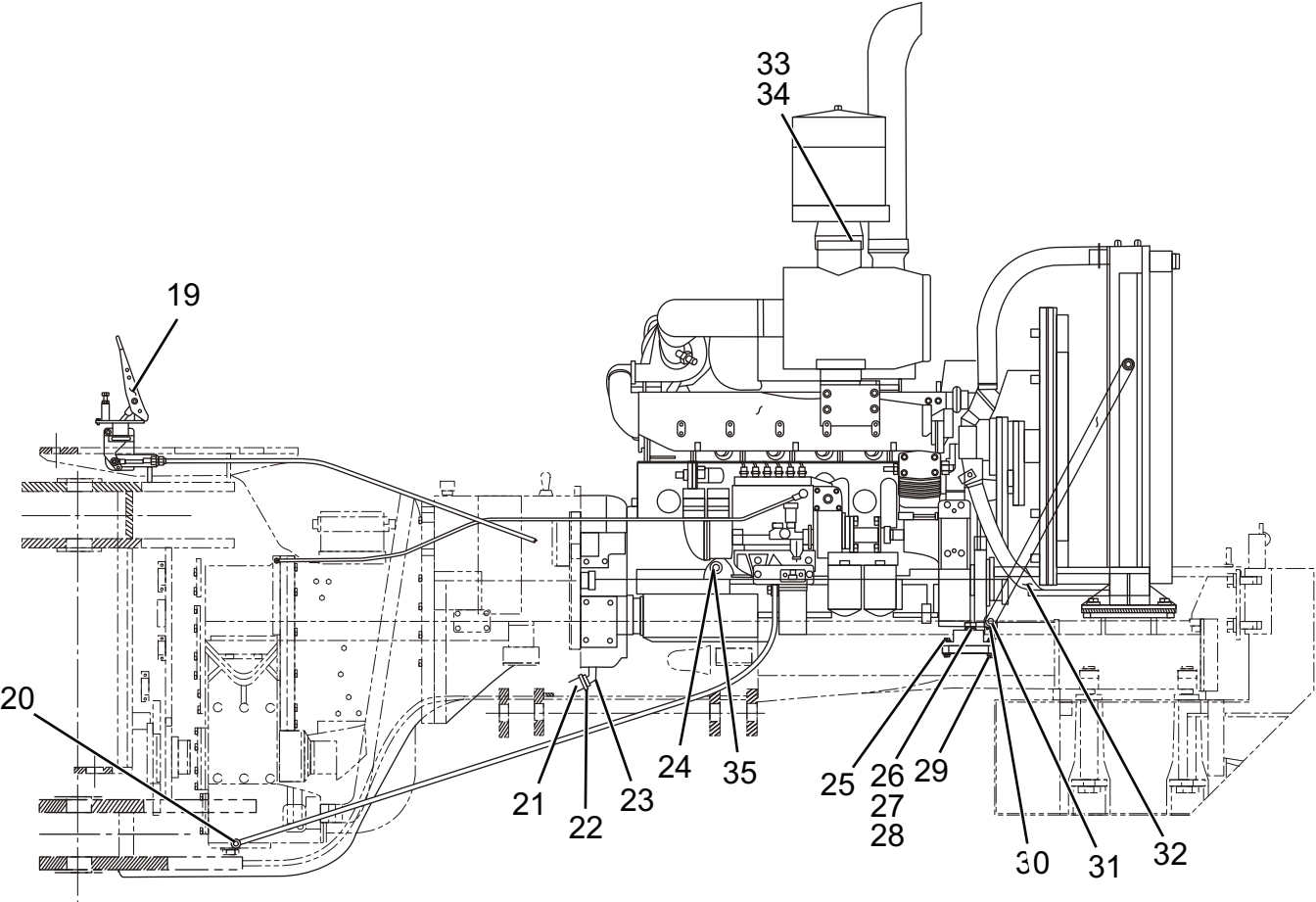

DIESEL ENGINE

柴油机系统 Diesel Engine system						
Item	Parts number	Chinese Description	English Description	Specification	Qty	Remarks
19	GB/T93-1987	垫圈	washer		3	
20	612600080790	柴油机进油管	Fuel inlet pipe		1	柴油机带
21	GB/T15329.1-2003	变矩器回油胶管	Torque converter oil return hose		1	
22	JB/T8870-1999	喉箍	Hoop	φ32-44	2	
23	LG853.01.02	变矩器回油接头	Torque converter oil return connector		1	401016-017B
24	LG853.01-002	测压接头	Pressure connector		1	403727
25	GB/T5782-2000	螺栓	Bolt	M14X70	4	8.8
26	GB/T5783-2000	螺栓	Bolt	M22X55	2	8.8
27	GB/T97.1-2002	垫圈	Washer	22	2	
28	GB/T93-1987	垫圈	Washer	22	2	
29	GB/T899.1-2000	锁紧螺母	Lockup nut	M14	4	8
30	LG860.01.06	E 型减震器	E-type absorber		2	EA-220
31	GB/T6170-2000	螺母	Nut	M12	2	8
32	612600160003	橡胶管	Rubber hose		1	柴油机带
33	CDM860.01.01	超强型卡箍	Clamp	(Φ180)	1	
34	CDM860.01-002	空气预滤器连接套	Air foreordain cleaner connecting sleeve		1	
35	LG853.01-002	测压接头	Pressure connector		1	403727

变矩器系统 (Torque converter system)

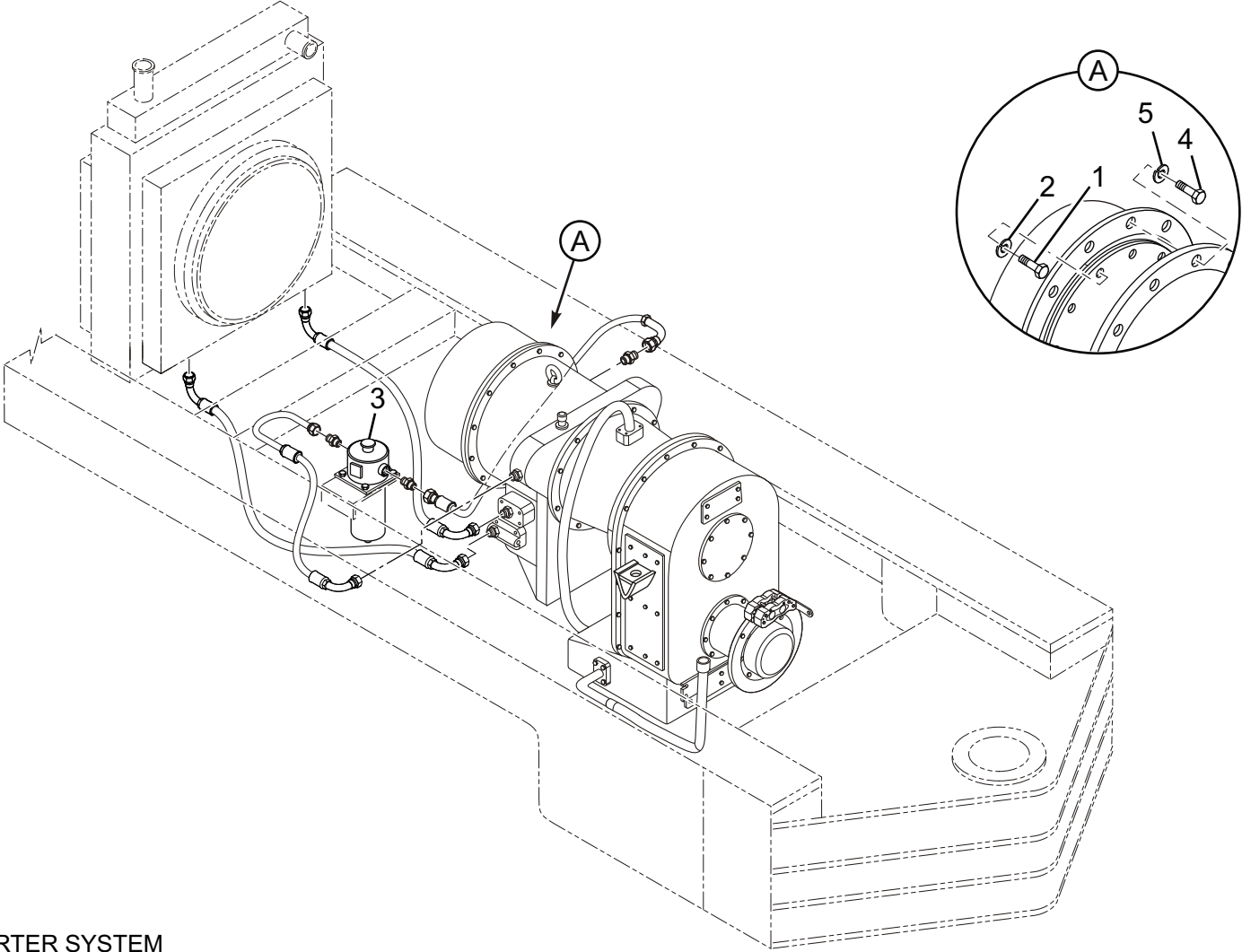

TORQUE CONVERTER SYSTEM

变矩器系统 Torque Converter System						
Item	Parts number	Chinese Description	English Description	Specification	Qty	Remarks
1	GB/T5785-2000	螺栓	Bolt	M10X1X40	12	变矩器自带
2	GB/T93-1987	垫圈	Washer	10	12	变矩器自带
3	CDM860.02.02	双变油路总成	Oil circuit of transmission and torque converter assembly		1	
4	GB/T5783-2000	螺栓	Bolt	M12X35	12	
5	GB/T93-1987	垫圈	Washer	12	12	

双变油路总成 (Oil circuit of transmission and torque assembly)

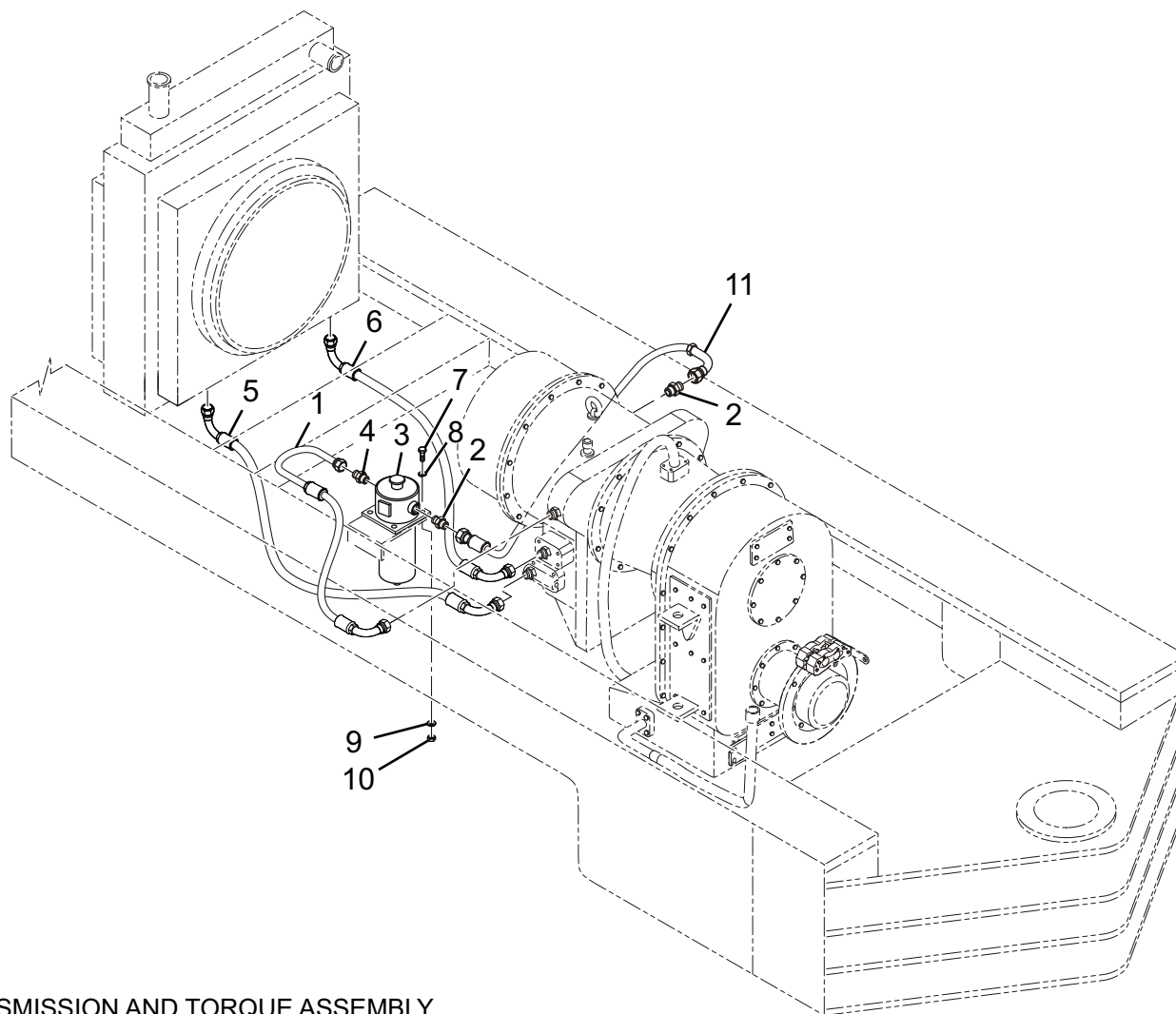

OIL CIRCUIT OF TRANSMISSION AND TORQUE ASSEMBLY

双变油路总成 Oil Circuit Of Transmission And Torque Assembly (CDM835E.02 I .02)						
Item	Parts number	Chinese Description	English Description	Specification	Qty	Remarks
1	20401-36T/20491-36T *2W16*900/270 °	变矩器到滤油器管	Hose from torque converter to oil filer		1	820
2	L1CH-36-27D	接头体	Adapter		2	
3	LG855.02.02.01	双变滤油器	Oil filter of transmission and torque converter		1	YFL-A400X25LS-G3
4	L1CH-36-30D	接头体	Adapter		1	
5	20491-36TGB*2W16 *2200/90 °	冷却器到变矩器胶管	Hose from cooler to torque converter	M8X35 8	1	
6	20491-36TGB*2W16 *2350/90 °	变矩器到冷却器胶管	Hose from torque converter to cooler	8 M8	1	2500
7	GB/T5783-2000	螺栓	Bolt		4	8.8
8	GB/T97.1-2002	垫圈	Washer		4	
9	GB/T93-1987	垫圈	Washer		4	
10	GB/T6170-2000	螺母	Nut		4	8
11	20491-36T/20411-36T *2W16*1600	滤油器到变速操纵阀胶管	Hose from oil filter to speed control valve		1	

变速箱系统 (Transmission system)

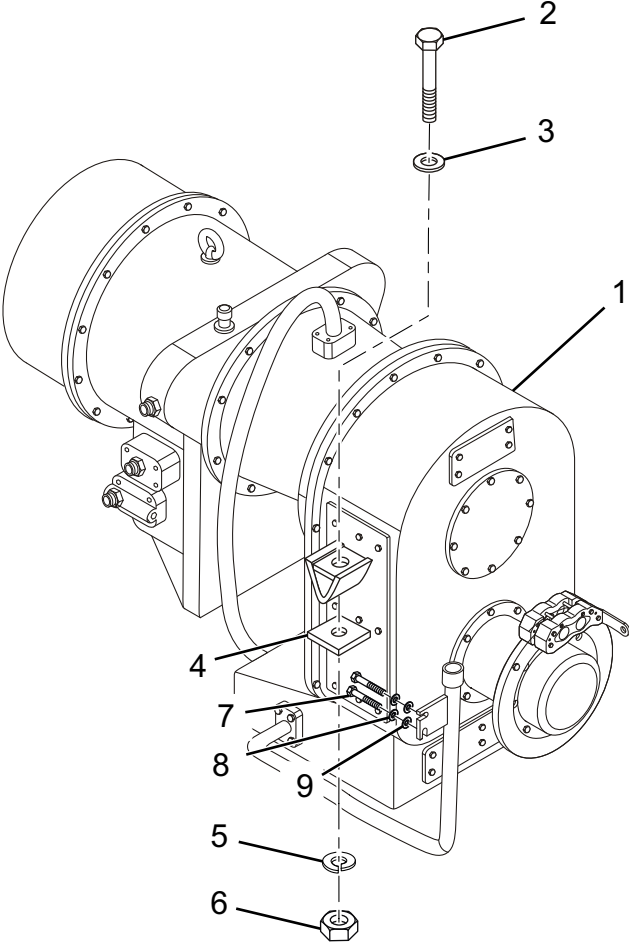

TRANSMISSION SYSTEM

变速箱系统 Transmission System						
Item	Parts number	Chinese Description	English Description	Specification	Qty	Remarks
1	LGS860C	液力变速箱总成	Hydraulic transmission assembly		1	
2	GB/T5782-2000	螺栓	Bolt	M18X140	2	8.8
3	GB/T97.1-2002	垫圈	Washer	18	2	
4	LG860.03-001	橡胶垫	Rubber pad		2	
5	LG860.03-002	弧形垫圈	Arc washer		2	
6	GB/T899.1-2000	螺母	Nut	M18	2	
7	GB/T5783-2000	螺栓	Bolt	M8X16	2	8.8
8	GB/T93-1987	垫圈	Washer	8	2	
9	GB/T97.1-2002	垫圈	Washer	8	2	

变速箱总成 Transmission Assembly (LGS860C)						
Item	Parts number	Chinese Description	English Description	Specification	Qty	Remarks
1	LGS18.02	分动箱总成	Transfer case		1	
2	GB/T119.2	销	Pin	12 × 60	1	
3	LGS860C.02	行星排总成	Planet lines assembly		1	8
4	LGS18-007	O 型圈	O-ring		12	
5	LGS18-003	插管	Cannula		6	
6	LGS18-004	密封垫	Seal gasket		1	
7	LGS18-002	过渡板	Transition plate		1	
8	LGS18-001	密封垫	Seal gasket		1	8.8
9	GB/T93	垫圈	Washer	10	30	
10	GB/T70.1	螺钉	Screw	M10 × 85	13	
11	4D180L	操纵阀	Control valve		1	
12	LGS860C-002	密封垫	Seal gasket	M10 × 85	1	
13	GB/T5782	螺栓	Bolt	M10 × 55	17	8
14	GB/T119.2	销	Pin	12 × 50	1	
15	GB1235-76	O 形圈	O-ring	42 × 3.5	2	
16	LGS860C.01	变矩器总成	Torque converter		1	
17	LGS860C-001	行星排壳体	Planet lines house		1	
18	GB/T5782	螺栓	Bolt	M14 × 70	13	

变速箱总成 Transmission Assembly (LGS860C)						
Item	Parts number	Chinese Description	English Description	Specification	Qty	Remarks
19	GB/T93	垫圈	Washer	14	13	
20	20491-52T*2W24 *1550/270°	吸油管	Oil suction pipe		1	

变矩器总成 Torque Converter Assembly LGS860C.01						
Item	Parts number	Chinese Description	English Description	Specification	Qty	Remarks
1	GB/T825	吊环螺钉	Eye screw	M20	1	
2	LGS860C.01-001	壳体	House		1	
3	LG853.03.01.12	透气管总成	Vent pipe		1	
4	GB/T894.1	轴用挡圈	Sprag for shaft	58	1	
5	GB/T5785	螺栓	Bolt	M10×1×40	12	
6	GB/T93	垫圈	Washer	10	36	
7	LGS18.01-002	齿圈	Ring gear		1	
8	LGS18.01-003	齿轮	Gear		1	
9	GB/T5783	螺栓	Bolt	M10×30	8	
10	GB/T5786	螺栓	Bolt	M12×1.5×30	8	
11	GB/T93	垫圈	Washer	12	10	
12	YJH340-13	变矩器机芯	Torque converter engine core		1	
13	GB/T5783	螺栓	Bolt	M12×45	3	
14	LGS18.01-004	压板 I	Press plate I		2	
15	LGS18.01-005	变速齿轮	Speed gear		2	
16	GB/T276	深沟球轴承	Deep channel ball bearing	6011	4	
17	LGS18.01-006	套筒	Sleeve		2	
18	LGS860C.01-002	变速轴	Speed shaft		1	

变矩器总成 Torque Converter Assembly LGS860C.01						
Item	Parts number	Chinese Description	English Description	Specification	Qty	Remarks
19	LG853.03.01.10-001	密封纸垫	Seal gasket		1	
20	GB/T276	深沟球轴承	Deep channel ball bearing	6012	2	
21	GB/T5782	螺栓	Bolt	M10×50	8	
22	GB/T5782	螺栓	Bolt	M10×90	2	
23	GB/T5782	螺栓	Bolt	M10×65	6	
24	CBG120/20	变速泵	Speed pump		1	
25	402111L	泵管接头	Pump pipe connector		1	
26	GB/T5625.1	管接头	Pipe connector	6	2	
27	LGS860C.01.01	油管组件	Oil pipe components		1	
28	GB/T5631.1	管接头	Pipe connector	6	1	
29	LGS18.01-008	输出齿轮	Output gear		1	
30	LGS18.01-009	输出轴	Output shaft		1	
31	LGS18.01-010	压板 II	press plate II		1	
32	JB/T8547	密封环	Seal ring	YH×65	1	
33	GB/T276	深沟球轴承	Deep channel ball bearing	6311	1	
34	GB/T893.1	孔用挡圈	Internal sprag	120	1	
35	LGS18.01-011	导轮座	Gear guide seat		1	
36	JB/T8547	密封环	Seal ring	YH×125	2	

变矩器总成 Torque Converter Assembly LGS860C.01						
Item	Parts number	Chinese Description	English Description	Specification	Qty	Remarks
37	LGS18.01-012	轴套	Shaft sleeve		1	
38	LGS18.01-013	推力轴承挡板	Thrust bearing baffle		1	
39	LGS18.01-014	调整垫片	Adjusting gasket		1 组	
40	GB/T301	推力球轴承	Thrust ball bearing	51113	1	
41	LGS18.01-015	隔圈	Separating ring		1	
42	LGS18.01-016	输入轴	Input shaft		1	
43	TY60A-3	润滑阀	Lubricating valve		1	
44	GB/T93	垫圈 8	Washer		8	
45	LGS18.01-019	纸垫	Paper gasket		1	
46	GB/T70.1	螺钉	Screw	M8×25	4	
47	LG853.02.01-005	管接头	Pipe connector		2	
48	LG853.02.01-016	油温感应塞	Oil temperature sensing plug	Z3/8	1	
49	JB/T982	组合垫圈	Combined washer	30	4	
50	LGS18.01-017	盖板纸垫	Cover plate paper gasket		1	
51	LGS18.01-018	盖板	Cover plate		1	
52	LGS860C.01-003	转向驱动轴	Steering drive shaft		1	
53	GB/T893.1	孔用挡圈	Internal sprag	95	1	
54	LG853.02.01-011	螺塞	Plug		1	

行星排总成 Planet Line Assembly						
Item	Parts number	Chinese Description	English Description	Specification	Qty	Remarks
1	GB/T812	圆螺母	Round nut	M45×1.5	1	
2	GB/T858	止动垫圈	Stop washer	45	1	
3	LGS18.03-002	输入齿轮	Input gear		1	
4	JB/T 8547	密封环	Seal ring	YH×35	2	
5	LGS18.03-001	油塞	Oil plug		1	
6	GB/T893.1	孔用挡圈	Internal sprag	130	1	
7	GB/T283	圆柱滚子轴承	Pillar roller bearing	NUP312E	1	
8	JB/T8547	密封环	Seal ring	YH×75	2	
9	LGS18.03-043	输入轴	Input shaft		1	
10	LGS860C.02-001	倒档油缸	Reverse cylinder		1	
11	GB/T119.2	销	Pin	12h6×40	2	
12	LGS18.03-004	倒档一档活塞	Reverse gear I piston		2	
13	LGS18.03.01	摩擦片主动片	Drive friction plate		18	
14	LGS18.03-006	摩擦片从动片	Driving friction plate		13	
15	GB/T893.1	孔用挡圈	Internal sprag	95	1	
16	GB/T276	深沟球轴承	Deep channel ball bearing	6012	1	
17	LGS18.03-070	弹簧	Spring		10	
18	LGS18.03-072	圆柱销	Pillar pin		10	

Figure 07

行星排总成 Planet Line Assembly						
Item	Parts number	Chinese Description	English Description	Specification	Qty	Remarks
19	LGS18.03-074	金属密封环	Metal seal ring		1	
20	LGS18.03-005	倒档行星架	Reverse gear planet carrier		1	
21	LGS18.03-007	倒档太阳轮	Reverse gear sun gear		1	
22	GB/T309	滚针	Needle	$\phi 5.5 \times 32$	72	
23	LGS18.03-075	倒档行星轮轴	Reverse gear planet gear shaft		3	
24	LGS18.03-073	倒档行星轮	Reverse gear planet gear		3	
25	LGS18.03-071	隔离套	Separating sleeve		10	
26	LGS18.03-069	止推垫片	Thrust gasket		6	
27	LGS18.03-009	倒档齿圈	Reverse gear ring gear		1	
28	LGS18.03-066	卡圈	Snap ring		1	
29	LGS18.03-008	方向档压盘	Steering gear press disc		1	
30	GB/T70.1	螺钉	Screw	M12 \times 120	2	
31	LGS18.03-063	止推垫片	Thrust gasket		12	
32	LGS18.03-065	隔离套	Separating sleeve		12	
33	LGS18.03-062	前档四档行星轮	Forward gear IV planet gear		6	
34	LGS18.03-068	前档四档行星轮轴	Forward gear IV planet gear gear		3	
35	GB/T309	滚针	Needle	$\phi 4 \times 24$	180	
36	LGS18.03-012	前档活塞	Forward gear piston		1	

Figure 07

行星排总成 Planet Line Assembly						
Item	Parts number	Chinese Description	English Description	Specification	Qty	Remarks
37	LGS18.03-011	前档齿圈	Forward gear ring gear		1	
38	LGS18.03-013	前档油缸	Forward gear cylinder		1	
39	GB/T893.1	孔用挡圈	Internal sprag	125	3	
40	GB/T894.1	轴用挡圈	Sprag for shaft	90	1	
41	LGS18.03-010	前档太阳轮	Forward gear sun gear		1	
42	GB/T894.1	轴用挡圈	Sprag for shaft	60	1	
43	LGS18.03-067	前档四档行星架	Forward gear IV planet carrier		1	
44	GB/T894.1	轴用挡圈	Sprag for shaft	82	2	
45	LGS18.03-014	四档太阳轮	Gear IV sun gear		1	
46	LGS18.03-015	金属密封环	Metal seal ring		1	
47	GB/T276	深沟球轴承	Deep channel ball bearing	61918	3	
48	LGS18.03-018	四档齿圈	Gear IV ring gear		1	
49	LGS18.03-016	四档活塞	Gear IV piston		1	
50	LGS18.03-017	卡圈	Snap ring		1	
51	LGS18.03-060	三档行星轮轴	Gear III planet gear shaft		3	
52	LGS18.03-059	止推垫片	Thrust gasket		6	
53	LGS18.03-058	隔离套	Separating sleeve		6	
54	GB/T309	滚针	Needle	φ 4 × 20	69	

Figure 07

行星排总成 Planet Line Assembly						
Item	Parts number	Chinese Description	English Description	Specification	Qty	Remarks
55	LGS18.03-056	三档行星轮	Gear III planet gear		3	
56	GB/T119.2	销	Pin	6s6×18 Pin	12	
57	LGS17.03-051	抱箍	Clamp	Clamp	10	
58	LGS18.03-061	三四档油缸	Gear III, IV cylinder		1	
59	LGS18.03-057	三四档前档内密封环	Forward gear III, IV inner seal ring		3	
60	LGS18.03-025	碟形弹簧	Belleville spring		3	
61	LGS18.03-027	二档活塞	Gear II piston		1	
62	LGS18.03-029	卡圈	Snap ring		1	
63	LGS18.03-028	三档齿圈	Gear III ring gear		1	
64	LGS18.03-030	螺钉	Screw		1	
65	GB/T308	钢球	Steel ball	5	1	
66	LGS18.03-031	二档油缸	Gear II cylinder		1	
67	LGS18.03-019	三档行星架	Gear III planet carrier		1	
68	LGS18.03-020	三档太阳轮	Gear III sun gear		1	
69	GB/T70.1	螺钉	Screw	M12×165	2	
70	LGS18.03-055	三档活塞	Gear III piston		1	
71	LGS18.03-054	弹簧	Spring		10	
72	LGS18.03-021	二档压盘	Gear II press plate		1	

Figure 07

行星排总成 Planet Line Assembly						
Item	Parts number	Chinese Description	English Description	Specification	Qty	Remarks
73	LGS18.03-023	二档摩擦片从动片	Gear II driven friction plate		3	
74	LGS18.03.02	二档摩擦片主动片	Gear II drive friction plate		4	
75	LGS18.03-022	二档离合器毂	Gear II clutch hub		1	
76	LGS18.03-076	轴用挡圈	Sprag for shaft		1	
77	LGS18.03-024	挡板	Sprag		1	
78	LGS18.03-053	二档外密封环	Gear II outer seal ring		1	
79	LGS18.03-052	二档内密封环	Gear II inner seal ring		1	
80	JB/T8547	密封环	Seal ring	YH×145	2	
81	LGS18.03-064	滑套	Sliding sleeve		1	
82	LGS18.03-042	输出轴	Input shaft		1	
83	GB/T70.1	螺钉	Screw	M12×140	2	
84	LGS18.03-026	油塞	Oil plug		3	
85	LGS18.03-044	滑套	Sliding sleeve		1	
86	GB/T276	深沟球轴承	Deep channel ball bearing	61926	1	
87	GB/T893.1	孔用挡圈	Internal sprag	180	1	
88	LGS18.03-032	金属密封环	Metal seal ring	72	1	
89	LGS18.03-041	一档行星架	Gear I planet carrier		1	
90	GB/T894.1	轴用挡圈	Sprag for shaft		2	

Figure 07

行星排总成 Planet Line Assembly						
Item	Parts number	Chinese Description	English Description	Specification	Qty	Remarks
91	LGS18.03-035	倒档一档内密封环	Reverse gear I seal ring		2	
92	LGS18.03-034	外密封环	Outer seal ring		5	
93	LGS18.03-033	螺栓	Bolt	M14	10	
94	GB/T97.1	垫圈	Washer	14	10	
95	GB/T119.2	销	Pin	12h6×25	6	
96	GB/T3452.1	O形密封圈	O-ring	92.5×3.55	1	
97	LGS860C.02-002	一档三档压盘	Gear I,III press disc		1	
98	GB/T3452.1	O形密封圈	O-ring	425×7	2	
99	GB/T119.2	销	Pin	4×12	1	
100	LGS18.03-051	二档轴套	Gear II shaft sleeve		1	
101	LGS18.03-039	压板	Press plate		2	
102	GB/T5783	螺栓	Bolt	M8×20	6	
103	LGS18.03-038	锁紧垫片	Lock gasket		6	
104	LGS18.03-040	一档太阳轮	Gear I sun gear		1	
105	LGS18.03-045	止推垫片	Thrust gasket		6	
106	LGS18.03-046	一档行星轮	Gear I planet gear		3	
107	LGS18.03-050	一档行星轮轴	Gear I planet gear shaft		3	
108		滚针轴承	Needle bearing	K28×35×18	6	

行星排总成 Planet Line Assembly						
Item	Parts number	Chinese Description	English Description	Specification	Qty	Remarks
109	LGS18.03-037	一档齿圈	Gear I ring gear		1	
110	LGS18.03-048	弹簧	Spring		20	
111	LGS18.03-047	圆柱销	Pillar pin		5	
112	LGS18.03-036	一档油缸	Gear I cylinder body		1	

分动箱总成 Transfer Case Assembly						
Item	Parts number	Chinese Description	English Description	Specification	Qty	Remarks
1	GB/T5783	螺栓	Bolt	M10×30	24	
2	GB/T93	垫圈	Washer	10	38	
3	LGS18.02.02-001	盖板	Cover plate		1	
4	LGS18.02.02-002	弹簧垫	Spring shim		1	
5	GB/T867	铆钉	Rivet	2.5×6	2	
6	GB/T3452.1	O 形圈	O-ring	92.5×3.55	1	
7	LGS18.02.04-002	磁铁	Magnet		3	
8	LGS18.02.04-001	磁铁支架	Magnet bracket		1	
9	LGS18.02.03	滤网	Filter screen		1	
10	402111L	泵管接头	Pump pipe connector		1	
11	JB/T982	组合垫圈	Combined washer	30	1	
12	LGS18.02-010	放油塞	Oil drain plug		1	
13	GB/T3452.1	O 形圈	O-ring	37.5×2.65	1	
14	GB1235-76	O 型圈	O-ring	45×3.5	1	
15	LG853.03.01-019	压盖	Press cover		1 副	
16	GB/T5783	螺栓	Bolt	M10×35	4	
17	LGS18.02-007	盖	Cover		1	
18	13050-10	检油塞	Oil check plug	NPT1/4	2	

分动箱总成 Transfer Case Assembly						
Item	Parts number	Chinese Description	English Description	Specification	Qty	Remarks
19	GB/T93	垫圈	Washer	20	12	
20	GB/T5783	螺栓	Bolt	M20×60	12	
21	403059-064D	加油管总成	Oil filling pipe assembly		1	
22	LGS18.02.01-006	输出被动齿轮	Driven output gear		1	
23	GB/T283	圆柱滚子轴承	Pillar roller bearing	NU2214E	1	
24	GB/T3452.1	O 形圈	O-ring	60×3.55	1	
25	LGS18.02.01-008	隔套	Separating sleeve		1	
26	GB1235-76	O 形圈	O-ring	145×3.1	1	
27	GB/T13871	骨架油封	Frame oil seal	B80×100×10	2	
28	GB/T13871	骨架油封	Frame oil seal	B80 × 100 × 10	2	
29	LGS18.02.01-007	前轴承座	Front bearing seat		1	
30	LGS18.02.07	制动器安装支架	Brake mounting bracket		1	
31	GB/T93	垫圈	Washer	14	8	
32	GB/T5782	螺栓	Bolt	M14 × 55	8	
33	LGS18.02.01.01-002	防尘盖	Dust proof cover		1	
34	LGS18.02.01.02-001	前输出法兰	Front output flange		1	
35	LG855.03.01-002	制动盘	Brake disc		1	
36	GB/T93	垫圈	Washer	16	8	

分动箱总成 Transfer Case Assembly						
Item	Parts number	Chinese Description	English Description	Specification	Qty	Remarks
37	GB/T5786	螺栓	Bolt	M16×1.5×35	8	
38	GB/T5780	螺栓	Bolt	M12×55	2	
39	GB/T93	垫圈	Washer	12	8	
40	LGS18.02.01-001	压板	Press plate		2	
41	LG855.03.01.03	驻车制动器	Parking brake		1	
42	GB/T5783	螺栓	Bolt	M12×35 (10.9)	4	
43	GB/T5783	螺栓	Bolt	M12 × 35	6	
44	LGS18.02-004	盖	Cover		1	
45	GB/T5782	螺栓	Bolt	M10 × 40	4	
46	GB/T3452.1	O 形圈	O-ring	170 × 5.3	1	
47	LGS18.02-002	吊耳板	Suspender plate		2	
48	LGS18.02-003	大端盖	Big end cover		1	
49	GB1235-76	O 形圈	O-ring	420 × 8.6	1	
50	LGS18.02-006	调整垫	Adjusting shim		1 组	
51	GB/T297	圆锥滚子轴承	Taper roller bearing	32926	2	
52	LGS18.02-005	输出主动齿轮	Drive output gear		1	
53	LGS18.02-001	分动箱箱体	Transfer case body		1	
54	LGS18.02.06	安装支架	Mounting bracket		2	

分动箱总成 Transfer Case Assembly						
Item	Parts number	Chinese Description	English Description	Specification	Qty	Remarks
55	GB/T3452.1	O 形圈	O-ring	115×3.55	1	
56	GB/T3452.1	O 型圈	O-ring	92.5×3.55	1	
57	LGS18.02.01-004	后轴承座	Rear bearing seat		1	
58	LGS18.02.01-005	输出轴	Output shaft		1	
59	LGS18.02-008	密封垫	Seal gasket		2	
60	LGS18.02-009	密封垫	Seal gasket		1	
61	LGS18.02.05	回油管组件	Oil return pipe components		1	
62	GB/T297	圆锥滚子轴承	Taper roller bearing	32014	2	
63	LGS18.02.01-003	调整垫	Adjusting shim		1 组	
64	GB/T3452.1	O 形圈	O-ring	112×3.55	1	
65	LGS18.02.01-002	油封座	Oil seal seat		1	
66	GB/T5782	螺栓	Bolt	M10×100	6	
67	LGS18.02.01.01-001	后输出法兰	Rear output flange		1	
68	GB/T3452.1	O 形圈	O-ring	54.5×5.3	1	

驱动桥系统 (Axle system)

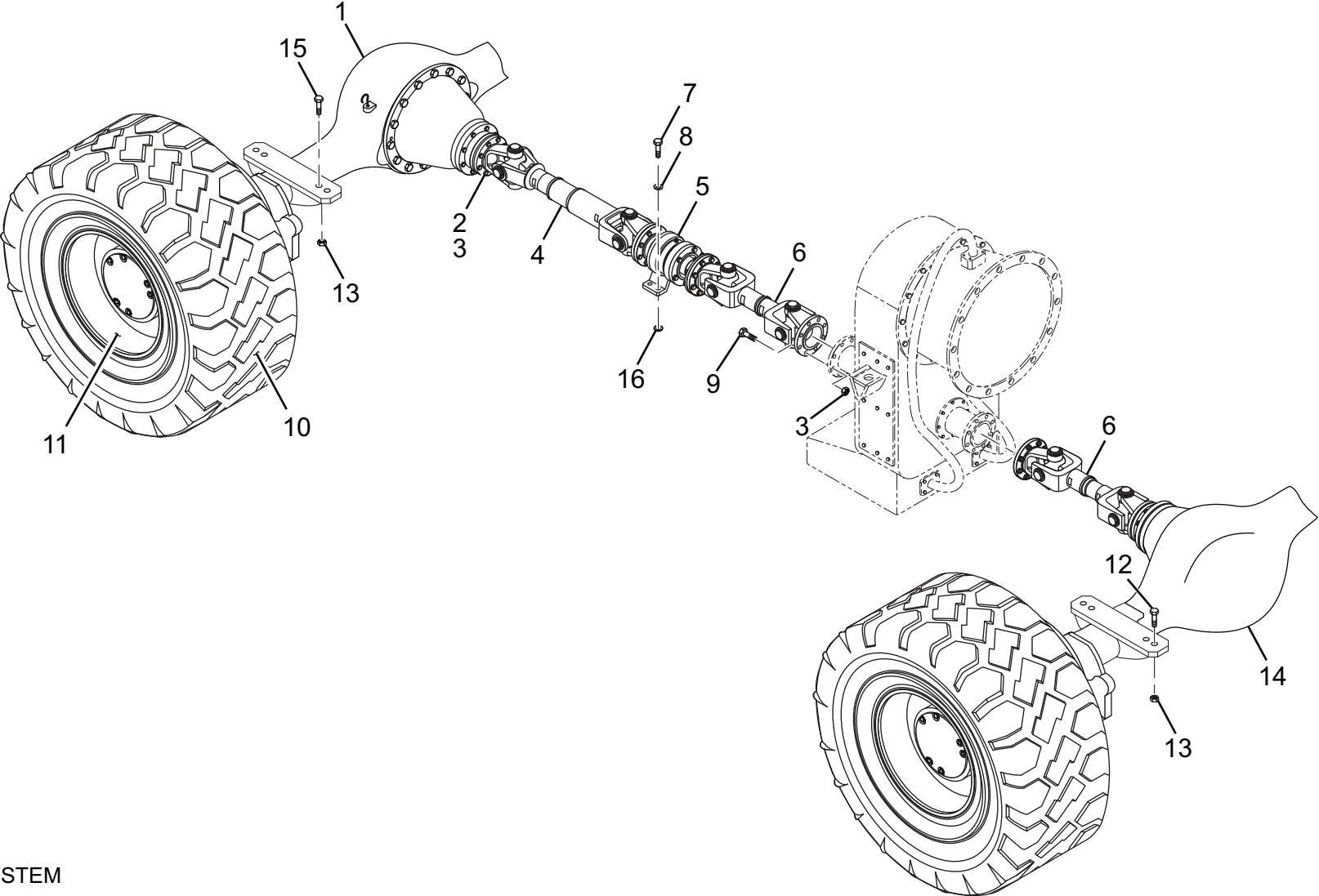

AXLE SYSTEM

驱动桥系统 Axle System						
Item	Parts number	Chinese Description	English Description	Specification	Qty	Remarks
1	LG860.04.01	前驱动桥总成	Front axle assembly		1	
2	GB/T5785-2000	螺栓	Bolt	14X1.5X50	16	
3	GB/T889.2-2000	防松螺母	Lock nut	M14X1.5	24	8
4	LG860.04.02	前传动轴总成	Front drive shaft assembly		1	
5	LG860.04.06	中间支承	Intermediate support		1	
6	LG860.04.03	中 / 后传动轴总成	Intermediate/Rear drive shaft assembly		2	
7	GB/T57832000	螺栓	Bolt	M16X50	4	8.8
8	GB/T93-1987	垫圈	Washer	16	4	
9	GB/T57852000	螺栓	Bolt	M14X1.5X55	8	
10	GB/T2980-2001	轮胎	Tyre	23.5-25-20PR TT E-3	4	
11	LG860.04.07	轮辋总成	Rim assembly		4	
12	LG860.04-002	后桥螺栓	Rear axle bolt		8	8
13	GB/T889.2-2000	防松螺母	Lock nut	M30X2	16	
14	LG860.04.05	后驱动桥总成	Rear axle assembly		1	
15	LG860.04-001	前桥螺栓	Front axle bolt		8	
16	GB/T97.1-2002	垫圈	Washer	16	4	

Figure 10

前驱动桥总成 Front Axle Assembly						
Item	Parts number	Chinese Description	English Description	Specification	Qty	Remarks
1	LG860.04.01.01	轮边减速器总成	Wheel- side reducer assembly		2	
2	LG853.04.01.03	钳盘式制动器总成	Caliper disc brake assembly		4	
3	LG853.04.01.03.02	制动片	Brake plate		8	
4	GB/T5785-2000	螺栓	Bolt	M20X1.5X56	16	
5	GB/T93-1987	垫圈	Washer	20	16	
6	LG860.04.01.02-003	制动盘支架	Brake disc bracket		2	
7	LG860.04.01.02-002	端轴	End shaft		2	
8	LG860.04.01-001	半轴	Axle shaft		2	
9	LG860.04.01.03	主减速器总成	Main reducer assembly		1	
10	LG860.04.01.02-001	桥壳	Axle case		1	
11	LG853.04.01.04	透气管	Vent pipe		1	
12	GB6173-86	螺母	Nut	M10X1	1	
13	GB/T5786-2000	螺栓	Bolt	M14X1.5X35	10	
14	GB/T93-1987	垫圈	Washer	14	14	
15	GB/T5786-2000	螺栓	Bolt	M14X1.5X45	2	
16	GB/T5786-2000	螺栓	Bolt	M14X1.5X60	2	
17	GB/T119.2	销	Pin	12X35	2	
18	LG853.04.01-023	螺塞	Plug		2	

Figure 11

主减速器总成 Main Reducer Assembly						
Item	Parts number	Chinese Description	English Description	Specification	Qty	Remarks
1	LG50F.04301A	锁紧螺母	Lock nut		1	
2	LG50F.04302A	垫圈	Washer		1	
3	LG860.04.01.03.01	输入法兰总成	Input flange assembly		1	
4	GB/T9877.1	油封	Oil seal	M20X1.5X56	2	
5	LG50F.04305A	密封盖	Seal cover	20	1	
6	GB/T5785	螺栓	Bolt		7	
7	GB/T93	垫圈	Washer		7	
8	GB/T297	轴承	Bearing		1	
9	LG50F.04307A	轴承隔套	Bearing separating sleeve		1 组	
10	LG50F.04308A	轴承座	bearing seat		1	
11	GB/T297	轴承	Bearing		1	
12	LG860.04.01.03.02-001	主动螺旋锥齿轮	Drive spiral bevel gear	M10X1	1	(前桥用)
13	GB/T894.1	档圈	Sprag	M14X1.5X35	1	
14		轴承	Bearing	14	1	
15	LG860.04.01.03.03-001	托架	Support	M14X1.5X45	1	
16	LG860.04.01.03-001	调整螺母	Adjusting nut	M14X1.5X60	2	
17	LG860.04.01.03.04	差速器总成	Differential assembly	12X35	1	
18	LG860.04.01.03.03-002	轴承套	Bearing sleeve	14	2	

主减速器总成 Main Reducer Assembly						
Item	Parts number	Chinese Description	English Description	Specification	Qty	Remarks
19	LG50F.04325A	螺栓	Bolt		4	
20	LG50F.04326A	铁丝	Iron wire	16#X500	2	
21	GB/T32.1	螺栓	Bolt	M10X1X20	2	
22	GB/T932	垫圈	Washer	10	2	
23	LG50F.04327A	锁紧片	Lock plate		2	
24	LG50F.04331A	调整垫	Adjusting shim		1 组	
25	LG50F.04332A	调整垫	Adjusting shim		1 组	
26	GB/T5785	螺栓	Bolt	M12X1.5X50	1	
27	GB/T93	垫圈	Washer	12	1	

Figure 12

差速器总成 Differential Assembly						
Item	Parts number	Chinese Description	English Description	Specification	Qty	Remarks
1		圆锥滚子轴承	Taper roller bearing	K580/K572X	2	
2	GB/T6187	螺母	Nut	M14X1.5	12	
3	LG860.04.01.03.04-001	差速器螺栓	Differential bolt		8	
4	LG860.04.01.03.04.01-001	差速器壳 II	Differential casell		1	
5	LG860.04.01.03.02-002	被动螺旋锥齿轮	Driven spiral bevel gear		1	
6	GB/T5785	螺栓	Bolt	M14X1.5X50	12	
7	LG50F.04318A	半轴齿轮垫片	Axle shaft gear gasket		2	
8	LG50F.04317A	半轴齿轮	Axle shaft gear		2	
9	LG50F.04320A	锥齿轮垫片	Bevel gear gasket		4	
10	LG50F.04321A	十字轴	Cross		1	
11	LG50F.04319A	锥齿轮	Bevel gear		4	
12	LG50F.04315A	差速器壳 I	Differential case I		1	
13	LG50F.04323A	差速器螺母	Differential nut		8	

Figure 13

轮边减速器总成 Wheel- Side Reducer Assembly						
Item	Parts number	Chinese Description	English Description	Specification	Qty	Remarks
1	GB/T5783	螺栓	Bolt	M12X25	7	
2	GB/T93	垫圈	Washer	12	7	
3	LG860.04.01.01-006	轮边端盖	Wheel-side end cover		1	
4	GB/T119.1	销	Pin	14m6X35	2	
5	LG50F.04413A	挡块	Block		1	
6	LG50F.04412A	半轴堵头	Axle shaft stopper		1	
7	LG50F.04411A	垫圈	Washer		2	
8	LG50F.04417A	垫圈	Washer		1	
9	LG50F.04418A	油塞	Oil plug		1	
10	LG860.04.01.01-004	行星架	Planet carrier		1	
11	LG860.04.01.01-001	行星轮架外壳	Planet gear bracket house		1	
12	GB/T894.1	档圈	Sprag	50	1	
13	LG860.04.01.01-007	太阳轮	Sun gear		1	
14	LG860.04.01.01-009	隔套	Separating sleeve		1	
15	LG860.04.01.01-010	圆螺母	Round nut		2	
16	GB/T858	垫圈	Washer	105	1	
17	LG860.04.01.01-011	锥套	Taper sleeve		1	
18	LG860.04.01.01.01-001	内齿圈支承盘	Inner ring gear support disc		1	

Figure 13

轮边减速器总成 Wheel- Side Reducer Assembly						
Item	Parts number	Chinese Description	English Description	Specification	Qty	Remarks
19	LG860.04.01.01.01-003	内齿圈	Inner ring gear		1	
20	LG860.04.01.01.01-002	卡环	Snap ring		1	
21	GB/T297	轴承	Bearing	32030	1	
22	LG860.04.01.01-016	轮辋螺栓	Wheel rim bolt		16	
23	LG860.04.01.01-012	轮毂	Wheel hub		1	
24	GB/T6171	螺母	Nut	M20X1.5	16	
25	GB/T93	垫圈	Washer	20	16	
26	LG860.04.01.01-013	制动盘	Brake disc		1	
27	GB/T93	垫圈	Washer	20	14	
28	GB/T5785-2000	螺栓	Bolt	M20X1.5X50-10.9	14	
29	LG860.04.01.01-015	轴套	Shaft sleeve		1	
30	GB/T9877.1	油封	Oil seal	FB180X210X15	2	
31	LG860.04.01.01-014	挡油板	Oil baffle		1	
32	GB/T297	轴承	Bearing	32028	1	
33	LG860.04.01.01-008	行星轮	Planet gear		4	
34	LG860.04.01.01-003	挡圈	Sprag		8	
35	GB/T309-84	滚针	Needle	6*30	248	
36	LG860.04.01.01-002	隔套	Separating sleeve		4	

Figure 13

轮边减速器总成 Wheel- Side Reducer Assembly						
Item	Parts number	Chinese Description	English Description	Specification	Qty	Remarks
37	LG860.04.01.01-005	行星轮轴	Planet gear shaft		4	
38	GB/T93	垫圈	Washer	14	24	
39	GB/T5785-2000	螺栓	Bolt	M14X1.5X40	24	
40	LG50F.04411A	垫圈	Washer		1	
41	LG50F.04416A	螺塞	Plug screw		1	
42	GB/T5783	螺栓	Bolt	M10X25	7	
43	GB/T93	垫圈	Washer	10	7	

后驱动桥总成 Rear Axle Assembly						
Item	Parts number	Chinese Description	English Description	Specification	Qty	Remarks
1	LG860.04.01.01	轮边减速器总成	Wheel-side reducer assembly		2	
2	LG853.04.01.03	钳盘式制动器总成	Caliper disc brake assembly		4	
3	LG853.04.01.03.02	制动片	Brake plate		8	
4	GB/T5785-2000	螺栓	Bolt	M20X1.5X56	16	
5	GB/T93-1987	垫圈	Washer	20	16	
6	LG860.04.01.02-003	制动盘支架	Brake disc bracket		2	
7	LG860.04.01.02-002	端轴	End cover		2	
8	LG860.04.01-001	半轴	Axle shaft		2	
9	LG860.04.05.02	主减速器总成	Main reducer assembly		1	
10	LG860.04.01.02-001	桥壳	Axle case		1	
11	LG853.04.01.04	透气管	Vent pipe		1	
12	GB6173-86	螺母	Nut	M10X1	1	
13	GB/T5786-2000	螺栓	Bolt	M14X1.5X35	10	
14	GB/T93-1987	垫圈	Washer	14	14	
15	GB/T5786-2000	螺栓	Bolt	M14X1.5X45	2	
16	GB/T5786-2000	螺栓	Bolt	M14X1.5X60	2	
17	GB/T119.2	销	Pin	12X35	2	
18	LG853.04.01-023	螺塞	Pulg		2	

Figure 15

主减速器总成 Main Reducer Assembly						
Item	Parts number	Chinese Description	English Description	Specification	Qty	Remarks
1	LG50F.04301A	锁紧螺母	Lock nut		1	
2	LG50F.04302A	垫圈	Washer		1	
3	LG860.04.01.03.01	输入法兰总成	Input flange assembly		1	
4	GB/T9877.1	油封	Oil seal	FB80X100X10	2	
5	LG50F.04305A	密封盖	Seal cover		1	
6	GB/T5785	螺栓	Bolt	M14X1.5X55	7	
7	GB/T93	垫圈	Washer	14	7	
8	GB/T297	轴承	Bearing	31313E/P6X	1	
9	LG50F.04307A	轴承隔套	Bearing separating sleeve		1 组	
10	LG50F.04308A	轴承座	Bearing seat		1	
11	GB/T297	轴承	Bearing	31314E/P6X	1	
12	LG860.04.05.02.01-001	主动螺旋锥齿轮	Driving spiral bevel gear		1	
13	GB/T894.1	档圈	Sprag	90	1	
14		轴承	Bearing	NJ2307X9	1	
15	LG860.04.01.03.03-001	托架	Support		1	
16	LG860.04.01.03-001	调整螺母	Adjusting nut		2	
17	LG860.04.01.03.04	差速器总成	Differential assembly		1	
18	LG860.04.01.03.03-002	轴承套	Bearing sleeve		2	

Figure 15

主减速器总成 Main Reducer Assembly						
Item	Parts number	Chinese Description	English Description	Specification	Qty	Remarks
19	LG50F.04325A	螺栓	Bolt		4	
20	LG50F.04326A	铁丝	Iron wire	16#X500	2	
21	GB/T32.1	螺栓	Bolt	M10X1X20	2	
22	GB/T932	垫圈	Washer	10	2	
23	LG50F.04327A	锁紧片	Lock plate		2	
24	LG50F.04331A	调整垫	Adjusting shim		1 组	
25	LG50F.04332A	调整垫	Adjusting shim		1 组	
26	GB/T5785	螺栓	Bolt	M12X1.5X50	1	
27	GB/T93	垫圈	Washer	12	1	

差速器总成 Differential Assembly						
Item	Parts number	Chinese Description	English Description	Specification	Qty	Remarks
1		圆锥滚子轴承	Taper roller bearing	K580/K572X	2	
2	GB/T6187	螺母	Nut	M14X1.5	12	
3	LG860.04.01.03.04-001	差速器螺栓	Differential bolt		8	
4	LG860.04.01.03.04.01-001	差速器壳 II	Differential case II		1	
5	LG860.04.05.02.01-002	被动螺旋锥齿轮	Driven spiral bevel gear		1	
6	GB/T5785	螺栓	Bolt	M14X1.5X50	12	
7	LG50F.04318A	半轴齿轮垫片	Axle shaft gear washer		2	
8	LG50F.04317A	半轴齿轮	Shaft gear		2	
9	LG50F.04320A	锥齿轮垫片	Bevel gear washer		4	
10	LG50F.04321A	十字轴	Cross		1	
11	LG50F.04319A	锥齿轮	Bevel gear		4	
12	LG50F.04315A	差速器壳 I	Differential case I		1	
13	LG50F.04323A	差速器螺母	Differential nut		8	

Figure 17

轮边减速器总成 Wheel-Side Reducer Assembly						
Item	Parts number	Chinese Description	English Description	Specification	Qty	Remarks
1	GB/T5783	螺栓	Bolt	M12X25	7	
2	GB/T93	垫圈	Washer	12	7	
3	LG860.04.01.01-006	轮边端盖	Wheel-side end cover		1	
4	GB/T119.1	销	Pin	14m6X35	2	
5	LG50F.04413A	挡块	Block		1	
6	LG50F.04412A	半轴堵头	Axle shaft stopper		1	
7	LG50F.04411A	垫圈	Washer		2	
8	LG50F.04417A	垫圈	Washer		1	
9	LG50F.04418A	油塞	Oil plug		1	
10	LG860.04.01.01-004	行星架	Planet bracket		1	
11	LG860.04.01.01-001	行星轮架外壳	Planet gear carrier house		1	
12	GB/T894.1	档圈	Sprag	50	1	
13	LG860.04.01.01-007	太阳轮	Sun gear		1	
14	LG860.04.01.01-009	隔套	Separating sleeve		1	
15	LG860.04.01.01-010	圆螺母	Round nut		2	
16	GB/T858	垫圈	Washer	105	1	
17	LG860.04.01.01-011	锥套	Taper sleeve		1	
18	LG860.04.01.01.01-001	内齿圈支承盘	Inner ring gear support		1	

Figure 17

轮边减速器总成 Wheel-Side Reducer Assembly						
Item	Parts number	Chinese Description	English Description	Specification	Qty	Remarks
19	LG860.04.01.01.01-003	内齿圈	Inner ring gear		1	
20	LG860.04.01.01.01-002	卡环	Snap ring		1	
21	GB/T297	轴承	Bearing	32030	1	
22	LG860.04.01.01-016	轮辋螺栓	Wheel rim bolt		16	
23	LG860.04.01.01-012	轮毂	Wheel hub		1	
24	GB/T6171	螺母	Nut	M20X1.5	16	
25	GB/T93	垫圈	Washer	20	16	
26	LG860.04.01.01-013	制动盘	Brake disc		1	
27	GB/T93	垫圈	Washer	20	14	
28	GB/T5785-2000	螺栓	Bolt	M20X1.5X50-10.9	14	
29	LG860.04.01.01-015	轴套	Shaft sleeve		1	
30	GB/T9877.1	油封	Oil seal	FB180X210X15	2	
31	LG860.04.01.01-014	挡油板	Oil baffle		1	
32	GB/T297	轴承	Bearing	32028	1	
33	LG860.04.01.01-008	行星轮	Planet gear		4	
34	LG860.04.01.01-003	挡圈	Sprag		8	
35	GB/T309-84	滚针	Needle	6*30	248	
36	LG860.04.01.01-002	隔套	Separating sleeve		4	

Figure 17

轮边减速器总成 Wheel-Side Reducer Assembly						
Item	Parts number	Chinese Description	English Description	Specification	Qty	Remarks
37	LG860.04.01.01-005	行星轮轴	Planet gear shaft		4	
38	GB/T93	垫圈	Washer	14	24	
39	GB/T5785-2000	螺栓	Bolt	M14X1.5X40	24	
40	LG50F.04411A	垫圈	Washer		1	
41	LG50F.04416A	螺塞	Plug screw		1	
42	GB/T5783	螺栓	Bolt	M10X25	7	
43	GB/T93	垫圈	Washer	10	7	

电液变速操纵系统 Electro-Hydraulic Shift Control System

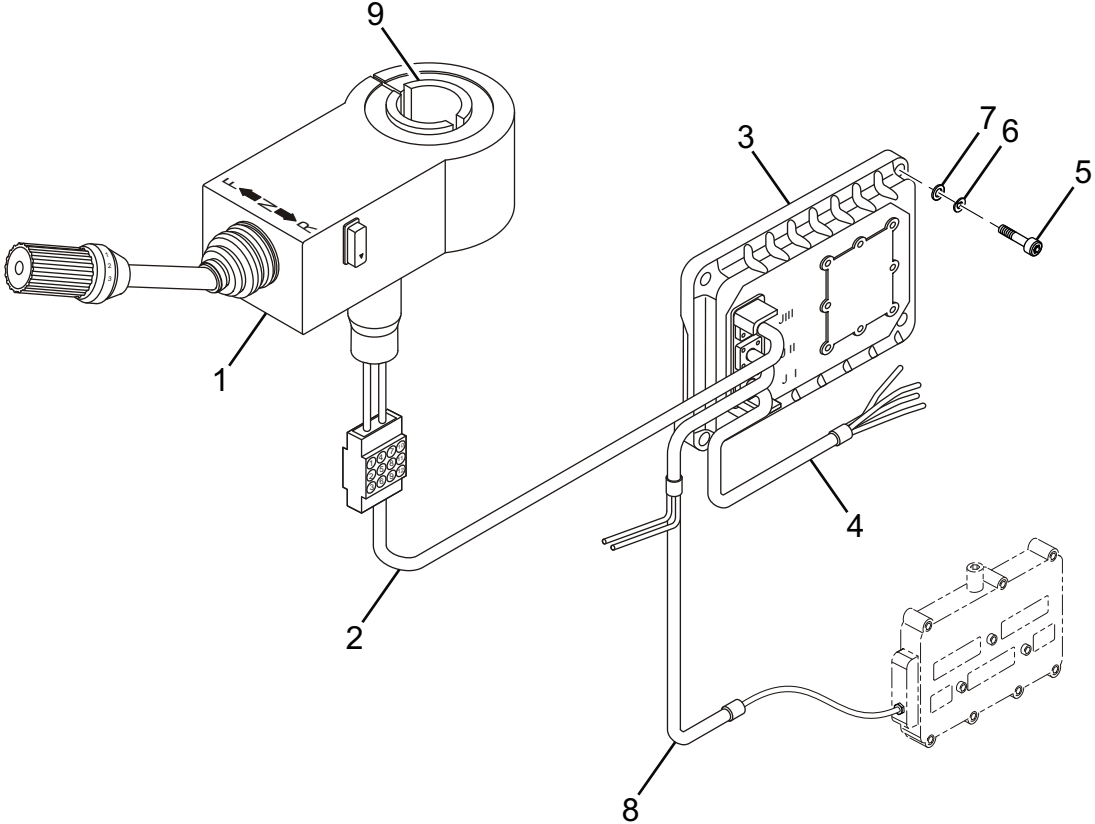

ELECTRO-HYDRAULIC SHIFT CONTROL SYSTEM

Figure 18

电液变速操纵系统 Electro-Hydraulic Shift Control System						
Item	Parts number	Chinese Description	English Description	Specification	Qty	Remarks
1	LG860.05.01	操纵手柄	Control handle		1	DW-3(前四后四)
2	LG856.05.08A	手柄线束	Handle harness		1	
3	LG860.05.04	控制器	Controller		1	
4	LG860.05.03	电源线束	Power harness		1	
5	GB/T70.1-1985	内六角圆柱头螺钉	Hexagon socket pillar head screw	M8X25	4	8.8
6	GB/T93-1987	垫圈	Washer		4	
7	GB/T97.1-2002	垫圈	Washer		4	
8	LG860.05.02	操纵阀线束	Control valve bundle		1	
9	LG856.05-001	手柄衬套	Handle bush		2	

Figure 19

转向液压系统 Hydraulic Steering system

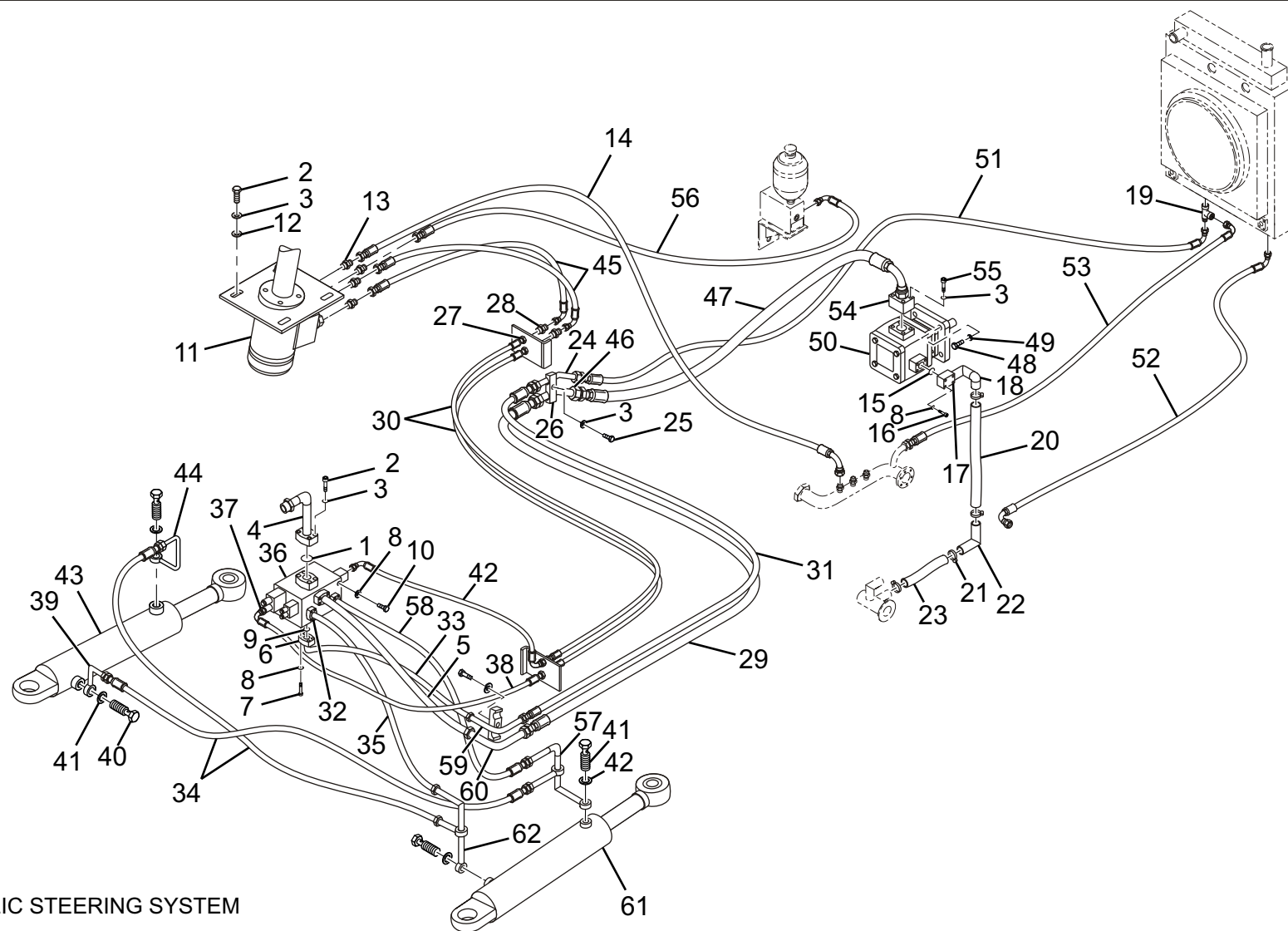

HYDRAULIC STEERING SYSTEM

Figure 19

转向液压系统 Hydraulic Steering system						
Item	Parts number	Chinese Description	English Description	Specification	Qty	Remarks
1	GB/T3452.1-2005	O 形圈	O-ring	32.5X3.55	3	
2	GB/T5783-2000	螺栓	Bolt	M10X30	16	8.8
3	GB/T93-1987	垫圈	Washer	10	30	
4	LG860.06.02	流量阀 PF 口钢管	Flow valve pipe for PF		1	
5	20411-36T/87311-20 *2N16*560	流量放大阀进油胶管	Flow amplifying valve oil inlet hose		1	
6	FL-20	法兰夹	Flange holder		3	
7	GB/T5783-2000	螺栓	Bolt	M12X40	8	8.8
8	GB/T93-1987	垫圈	Washer	12	19	
9	GB/T3452.1-2005	O 形圈	O-ring	37.5X3.55	3	
10	GB/T5782-2000	螺栓	Bolt	M12X110	3	8.8
11	LG860.06.01	全液压转向机	Hydraulic steering gear		1	
12	GB/T97.1-2002	垫圈	Washer	10	12	
13	L1DH-16-20	接头体	Adapter		4	
14	20511-16T*1W05*1250	转向器回油胶管	Steering gear oil return hose		1	
15	GB/T3452.1-2005	O 形圈	O-ring	47.5X3.55	1	
16	GB/T5783-2000	螺栓	Bolt	M12X35	4	8.8
17	FL-24	法兰夹	Flange holder		1	

Figure 19

转向液压系统 Hydraulic Steering system

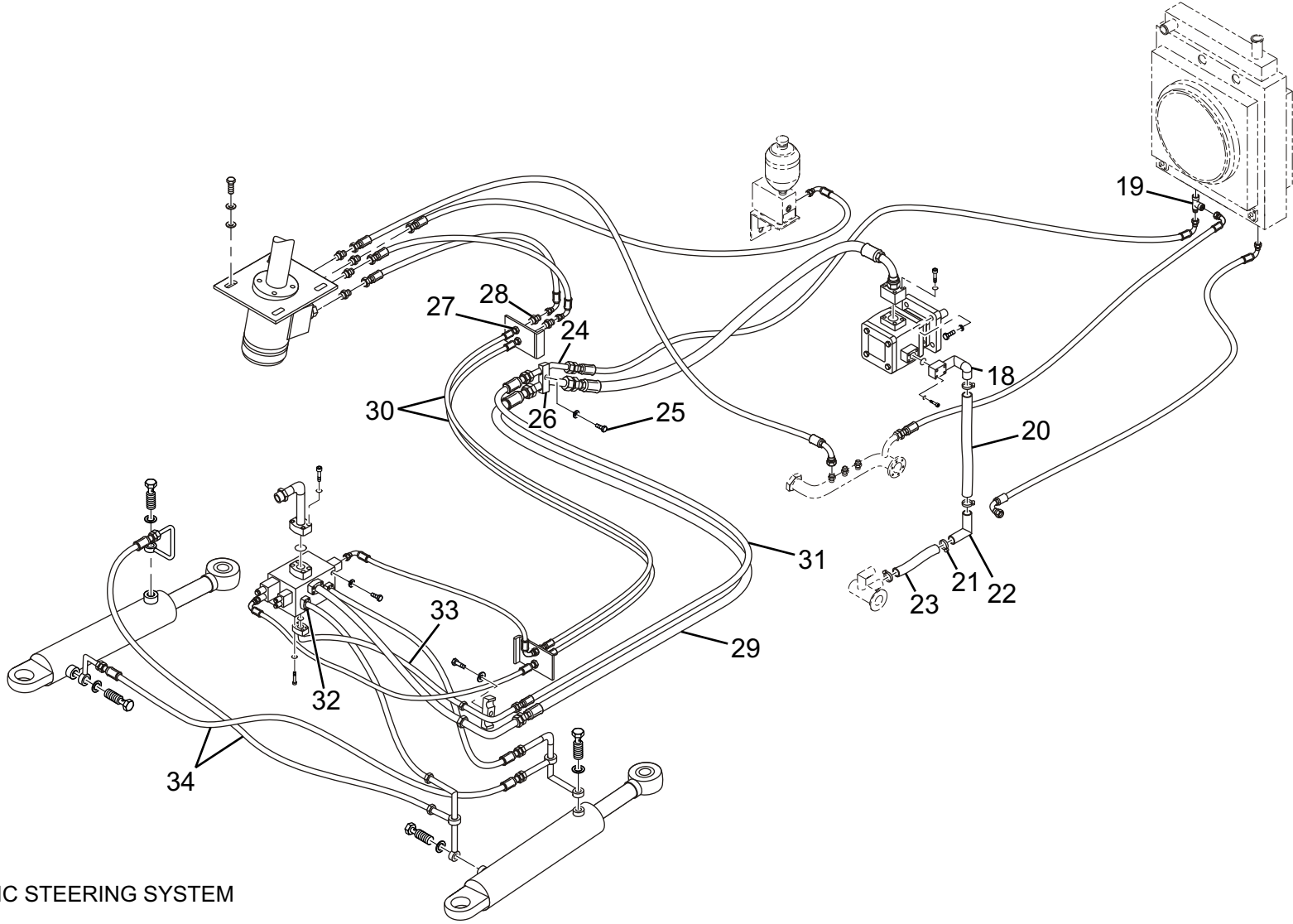

HYDRAULIC STEERING SYSTEM

Figure 19

转向液压系统 Hydraulic Steering system						
Item	Parts number	Chinese Description	English Description	Specification	Qty	Remarks
18	CDM860.06.03	转向泵进油钢管	Steering pump oil inlet pipe		1	
19	LCC-27	三通接头	T- connector		1	
20	φ51X4-L486	转向泵吸油胶管	Steering pump oil suction hose		1	
21	JB/T8870-1997	喉箍	Hoop	φ51~70	4	
22	CDM860.06.04	吸油过渡钢管	Oil suction transition pipe		1	
23	φ51X4-L520	过渡胶管	Transition hose		1	
24	LG860.06.05	后车架回油过渡钢管	Rear frame oil return transition pipe		1	
25	GB/T5783-2000	螺栓	Bolt	M10X40	2	8.8
26	LG860.06-001	压板	Press plate		1	
27	L8C-16	螺纹锁母	Nut		4	8
28	L6D-16	过板接头	Adapter		4	
29	20412-36T*2N16*1260	转向铰接进油胶管	Steering articulated oil inlet hose		1	
30	20511-16T*2W05*1152	先导控制胶管	Pilot control hose		2	
31	20411-27T*2W12*1260	转向铰接回油胶管	Steering articulated oil return hose		1	
32	FL-16	法兰夹	Flange holder		2	
33	20411-27T/87391-20	流量放大阀回油胶管	Flow amplifying valve oil return hose		1	
	*2W12*540					
34	20411-27T*2W12*650	转向油缸间胶管	Hose between steering cylinder		2	

转向液压系统 Hydraulic Steering system

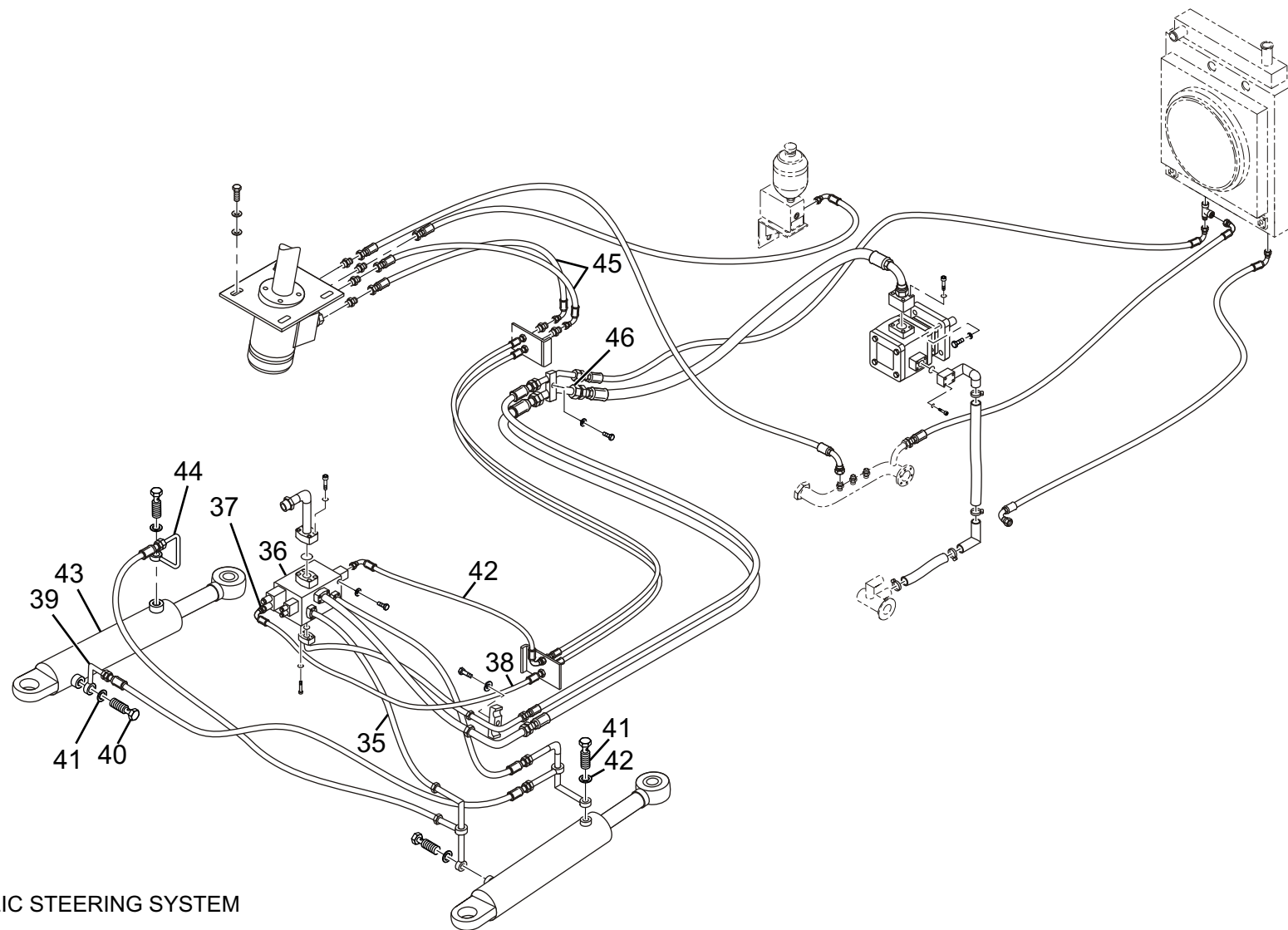

HYDRAULIC STEERING SYSTEM

转向液压系统 Hydraulic Steering system						
Item	Parts number	Chinese Description	English Description	Specification	Qty	Remarks
35	87311-16/20411-27T *2W12*550	流量放大阀 B 口胶管	Flow amplifying valve hose for B		1	
36	ZLF25A11	流量放大阀	Flow amplifying valve		1	临海海宏
37	L1DH-16-14	接头体	Adapter		2	
38	20511-16T/20591-16T *2W05*800	b 口先导胶管	Pilot hose for B		1	
39	LG860.06.06	右转向油缸大腔钢管	Big chamber pipe of right steering cylinder		1	
40	700M-22	铰接螺栓	Articulated bolt		4	
41	JB/T982-1977	垫圈	washer	22	8	
42	20591-16T*2W05*580 /180°	a 口先导胶管	Pilot hose for A		1	
43	CDM855.06.14	右转向油缸	Right steering cylinder		1	
44	LG860.06.07	右转向油缸小腔钢管	Small chamber pipe of right steering cylinder		1	
45	20511-16T/20591-16T *1W05*1152	转向器出油胶管	Steering gear oil outlet hose Rear frame oil inlet pipe		2	
46	LG860.06.08	后车架进油钢管	Steering pump oil outlet hose		1	

转向液压系统 Hydraulic Steering system

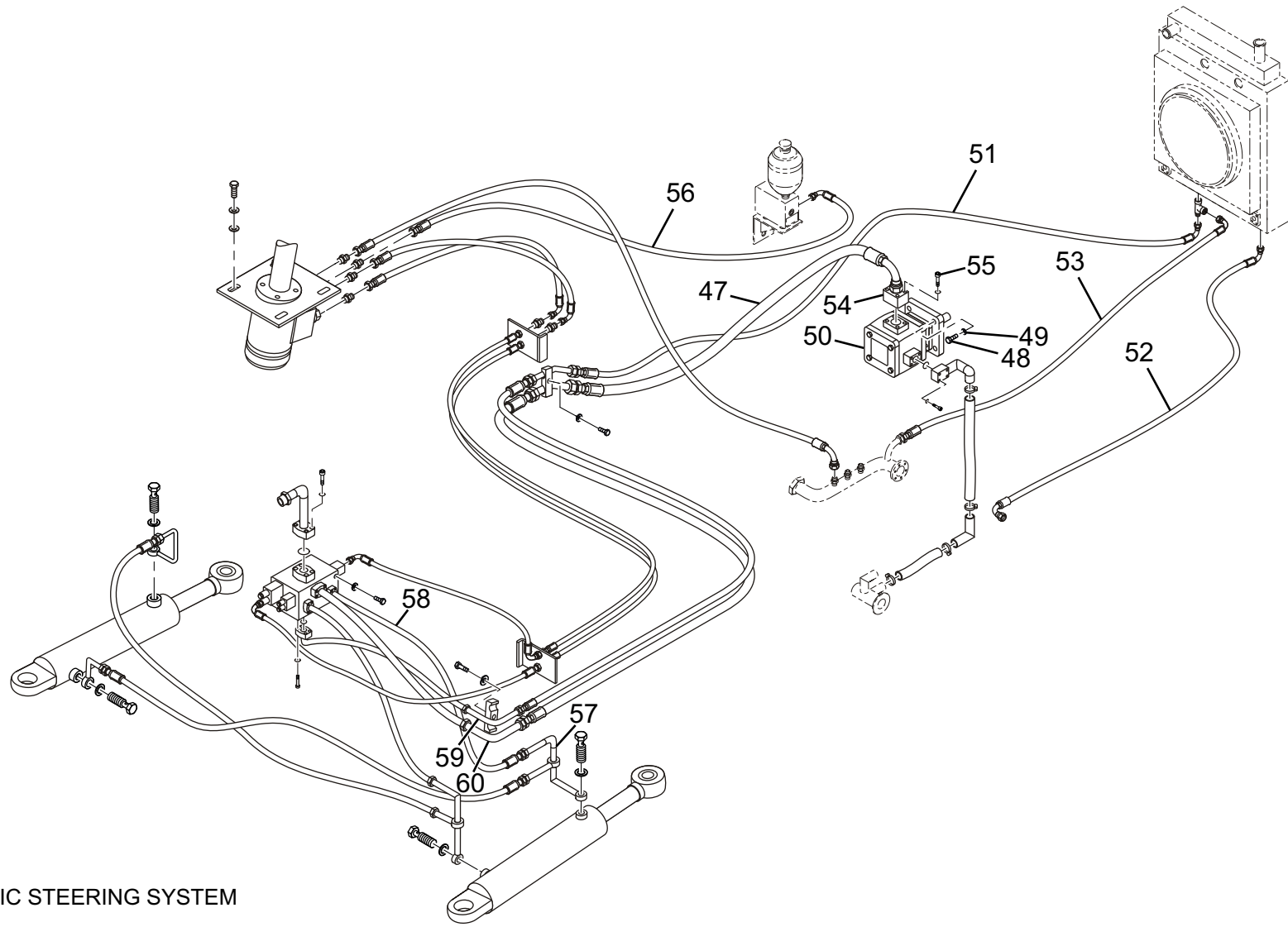

HYDRAULIC STEERING SYSTEM

Figure 19

转向液压系统 Hydraulic Steering system						
Item	Parts number	Chinese Description	English Description	Specification	Qty	Remarks
47	20411-36T/87311-20 *2N16*1850	转向泵出油胶管	Steering pump oil outlet hose		1	
48	GB/T5783-2000	螺栓	Bolt	M12X40	4	8.8
49	GB/T97.1-2002	垫圈	Washer	12	4	
50	P7600-F80NL467 6G	转向泵	Steering pump		1	泊姆克
51	20411-27T/20491-27T *1W12*3300	转向回冷却器胶管	Hose from steering gear to cooler		1	
52	20491-27T*1W12*3000 /90 °	冷却回油胶管	Cooling oil return hose		1	
53	20411-27T*1W12*3100	冷却胶管	Cooling hose		1	
54	LG860.06.09	转向泵出油过渡板	Steering pump oil outlet transition board		1	
55	GB/T5782-2000	螺栓	Bolt	M10X65	4	8.8
56	20511-16T*1W05*1600	转向器进油胶管	Steering gear oil inlet hose		1	
57	LG860.06.10	左转向油缸小腔钢管	Small chamber pipe of left steering cylinder		1	
58	20411-27T/87311-16 *2W12*640	流量放大阀 A 口胶管	Flow amplifying valve hose A		1	
59	LG860.06.11	前车架回油过渡钢管	Front frame oil return transition pipe		1	
60	LG860.06.12	前车架进油过渡钢管	Front frame oil inlet transition pipe		1	

Figure 19

转向液压系统 Hydraulic Steering system

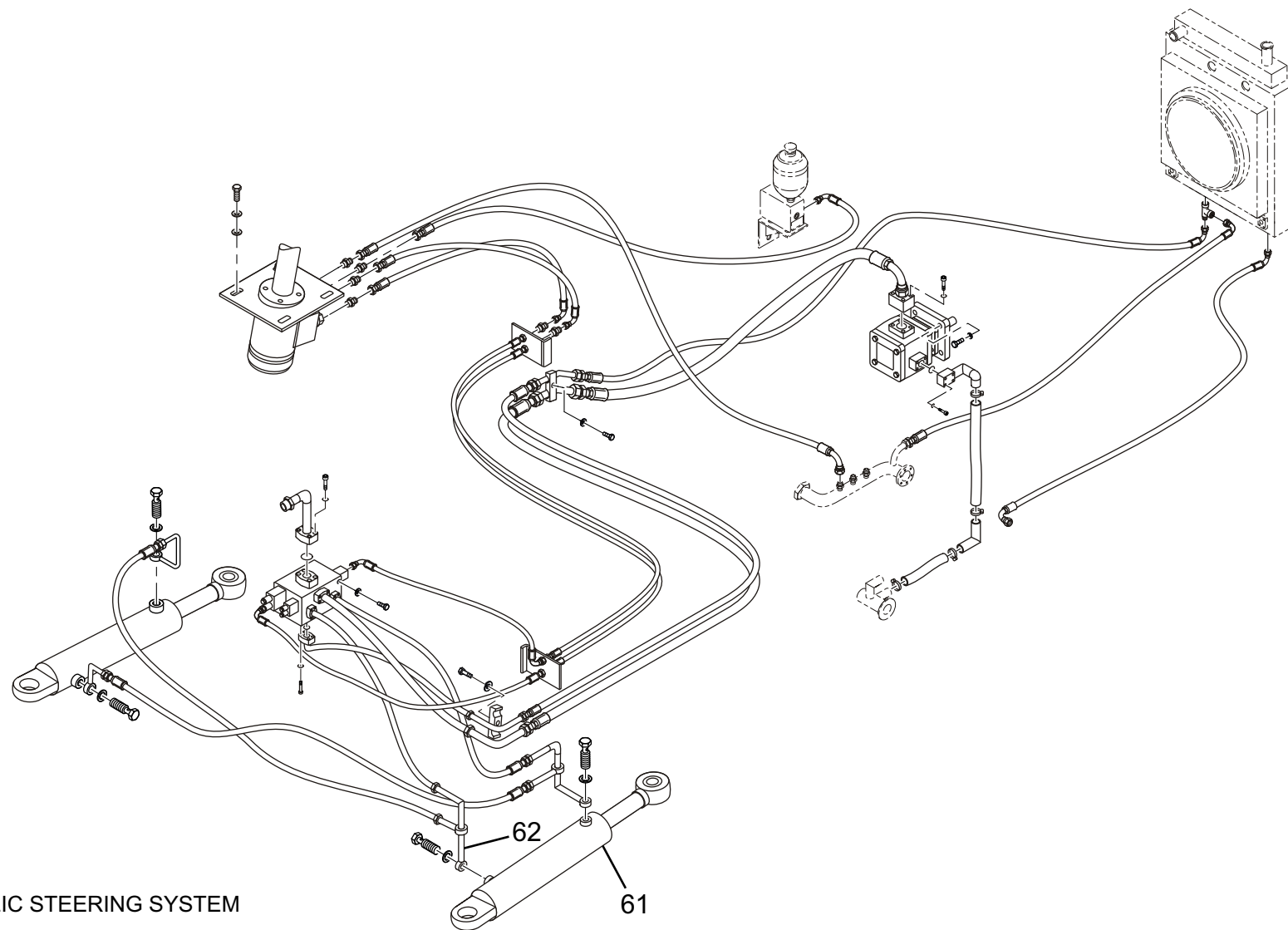

HYDRAULIC STEERING SYSTEM

转向液压系统 Hydraulic Steering system						
Item	Parts number	Chinese Description	English Description	Specification	Qty	Remarks
61	CDM855.06.13	左转向油缸	Left steering cylinder		1	
62	LG860.06.13	左转向油缸大腔钢管	Big chamber pipe of left steering cylinder		1	

全液压转向机 Hydraulic Steering Gear (LG860.06.01)

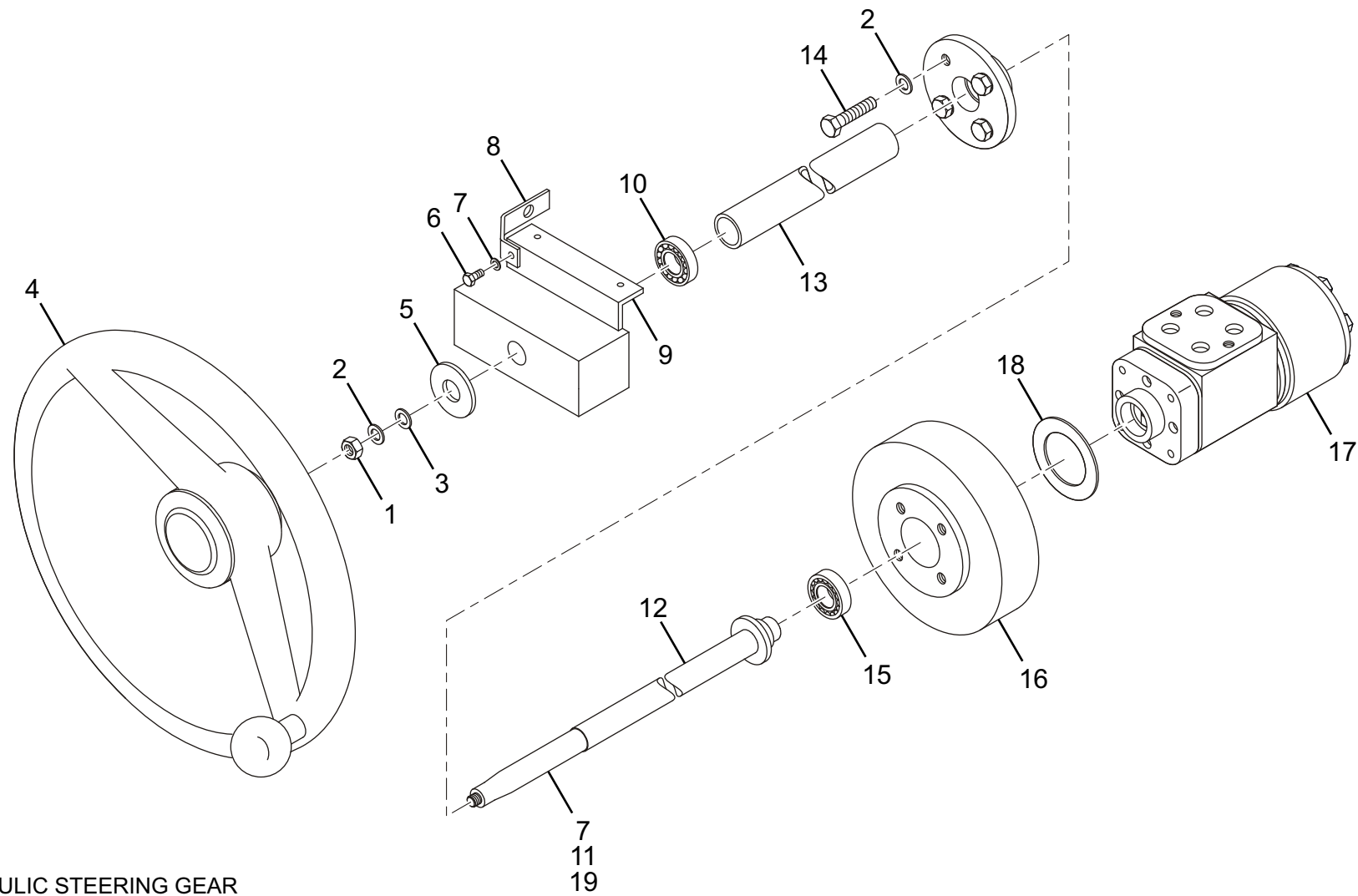

HYDRAULIC STEERING GEAR

全液压转向机 Hydraulic Steering Gear (LG860.06.01)						
Item	Parts number	Chinese Description	English Description	Specification	Qty	Remarks
1	GB/T6170	螺母	Nut	M10	1	
2	GB/T93	垫圈	Washer	10	5	
3	GB/T97.1	垫圈	Washer	10	1	
4	LG855.06.02.01	方向盘总成	Steering wheel assembly		1	
5	LG853.06.02.02	导电套	Conducting sleeve		1	
6	GB/T5783	螺栓	Bolt	M6 × 12	2	
7	GB/T93	垫圈	Washer	6	3	
8	LG853.06.02-001	电锁固定板	Electronic lock securing board		1	
9	LG853.06.02.03	组合开关固定板	Combined switch securing board		1	
10	GB276-89	单列向心球轴承	Single row radial ball bearing	104	1	
11	GB/T5783	螺栓	Bolt	M6 × 20	1	
12	LG853.06.02.04	转向轴	Steering shaft		1	
13	LG853.06.02.05	外套管	Outer sheath		1	
14	GB/T5782	螺栓	Bolt	M10 × 85	4	
15	GB/T301-1995	滚动轴承	Roller bearing	51106	1	
16	LG853.06.02.08	管座	Pipe seat		1	
17	BZZ3-E50C	全液压转向机	Hydraulic steering gear with valve block		1	

全液压转向机 Hydraulic Steering Gear (LG860.06.01)

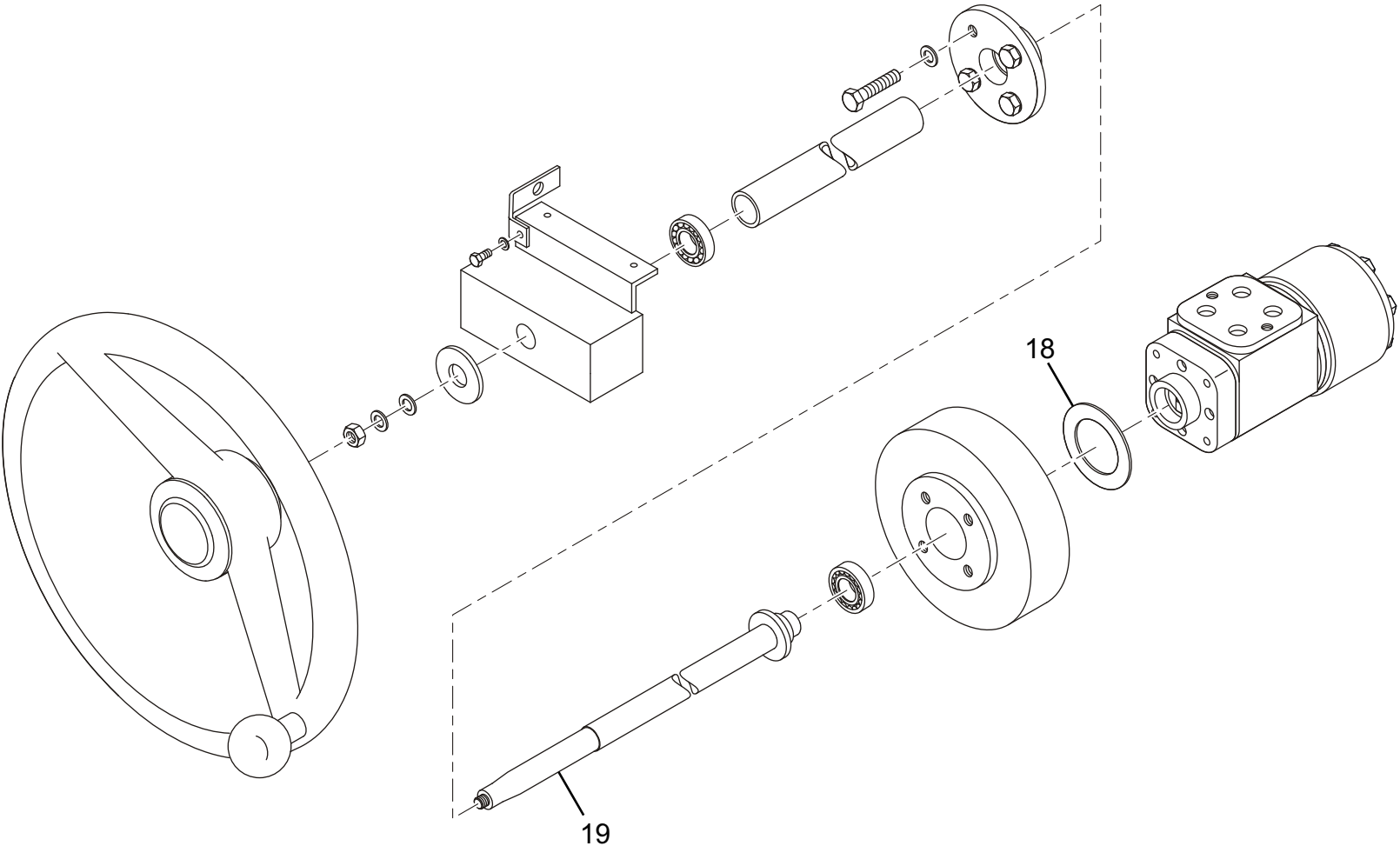

HYDRAULIC STEERING GEAR

全液压转向机 Hydraulic Steering Gear (LG860.06.01)						
Item	Parts number	Chinese Description	English Description	Specification	Qty	Remarks
18	LG853.06.02-003	调整垫	Adjusting gasket		1	
19	GB/T6170	螺母	Nut	M6	1	

Figure 21

转向油缸 Steering Cylinder (CDM855.06.13/CDM855.06.14)

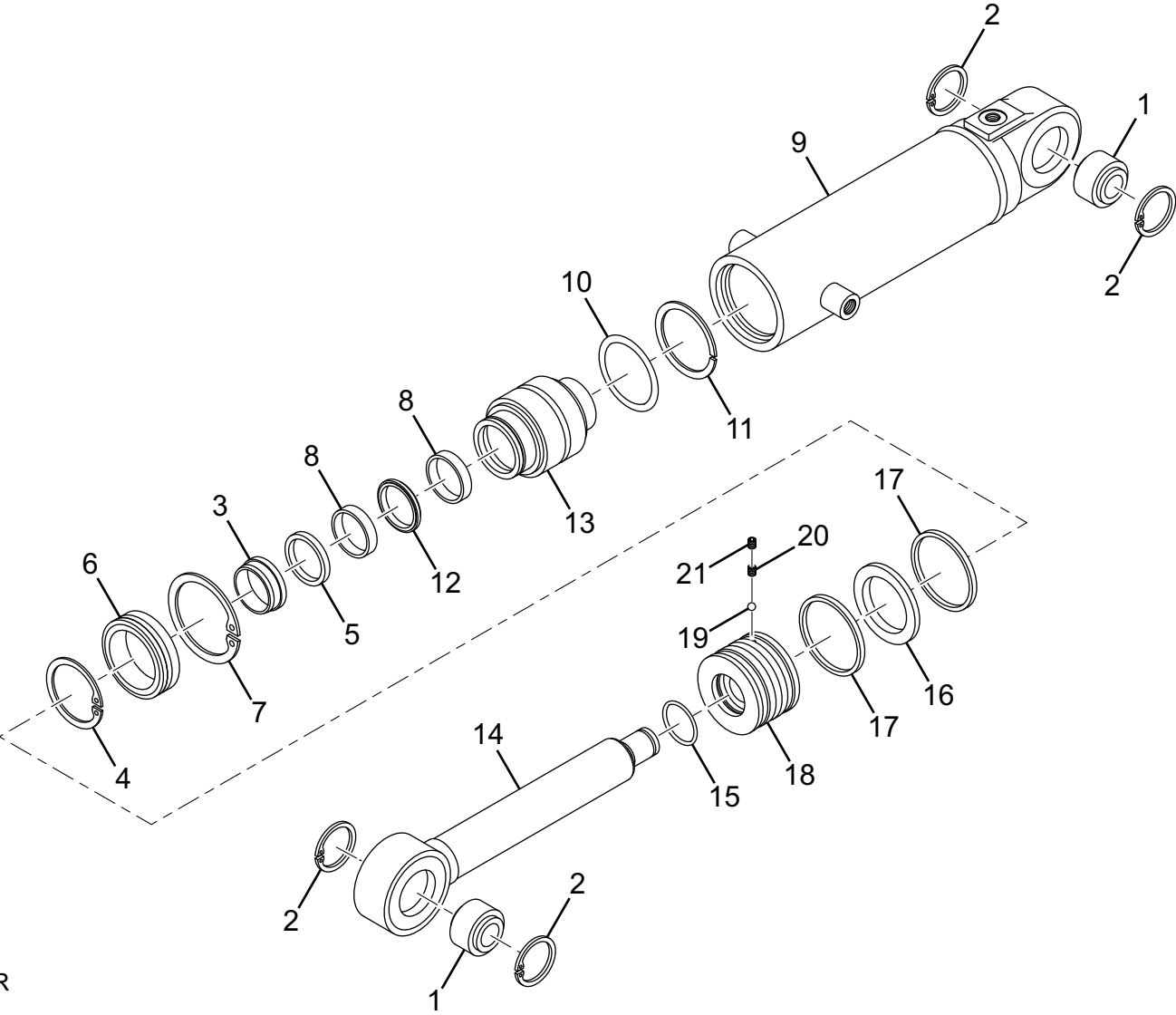

STEERING CYLINDER

Figure 21

转向油缸 Steering Cylinder (CDM855.06.13/CDM855.06.14)						
Item	Parts number	Chinese Description	English Description	Specification	Qty	Remarks
1	JB/T8879-2001	关节轴承	Joint bearing	GE50ES-C3	2	
2	GB/T893.1	孔用弹性挡圈	Circlip for hole	75	4	65Mn
3	AF 055A Z5071	防尘圈	Dust ring	55 × 69 × 8	1	金属骨架聚胺脂
4	GB/T894.1	轴用弹性挡圈 90	Circlip for shaft		1	65Mn
5	BS 5564 P5008	活塞杆密封圈	Piston seal ring	55 × 65 × 10	1	PU
6	ZL50F-630001B	环	Ring		1	45
7	ZL50F-630002A	弹簧挡圈	Circlip		1	碳素弹簧钢丝 II 组
8	FR 5507 Q5029	支承环	Support ring	55 × 60 × 9.7	2	增强酚醛夹布
9	ZL50F-631000B	缸体	Cylinder body		1	
10	2-341	O 形圈	O-ring	Φ88.27 × 5.33	1	NBR80
11		挡圈	Circlip	100 × 91 × 1.52	1	聚四氟乙烯
12	BR 055A 00601	缓冲圈	Bumper ring	55 × 70.5 × 6	1	PTFE+NBR
13	CDM855.06.13-01	导向套	Guide sleeve		1	QT450-10
14	CDM856.630001	活塞杆	Piston rod		1	45
15	2-227	O 形圈	O-ring	Φ53.57 × 3.53	1	NBR80
16	KR 0100 00701	活塞密封圈	Piston seal ring	100 × 84.5 × 6.3	1	PTFE+NBR
17	FR 9510 Q5029	支承环	Support ring	95 × 100 × 9.7	2	增强酚醛夹布
18	ZL50F-630005C	活塞	Piston		1	45

Figure 21

转向油缸 Steering Cylinder (CDM855.06.13/CDM855.06.14)

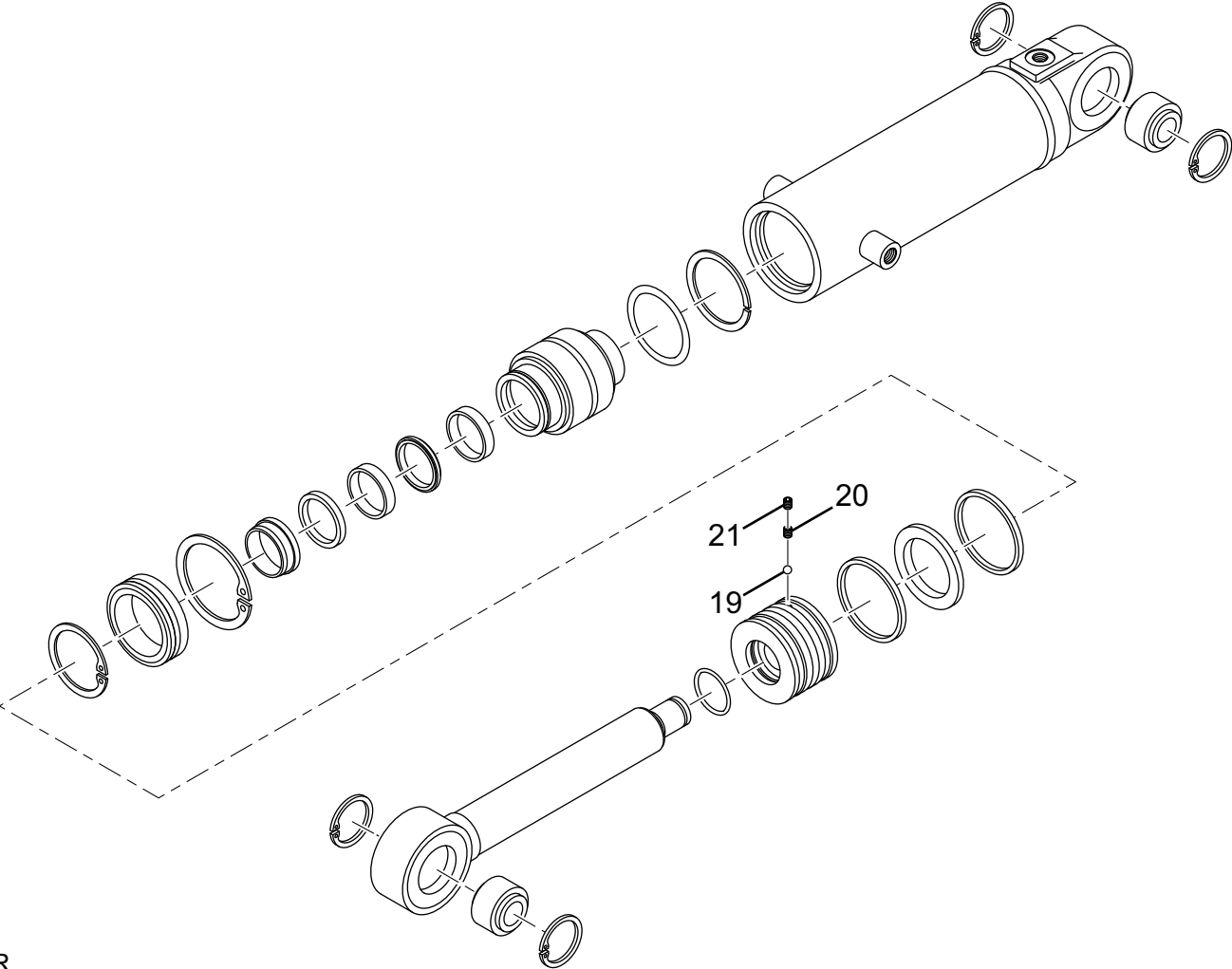

STEERING CYLINDER

转向油缸 Steering Cylinder (CDM855.06.13/CDM855.06.14)						
Item	Parts number	Chinese Description	English Description	Specification	Qty	Remarks
19	GB/T308-1989	钢球	Steel ball	SΦ5.5	1	
20	GB/T77-2000	螺钉	Screw	M8 × 16	1	
21	GB/T77-2000	螺钉	Screw	M8 × 10	1	

Figure 22

工作液压系统 (Implement Hydraulic system)

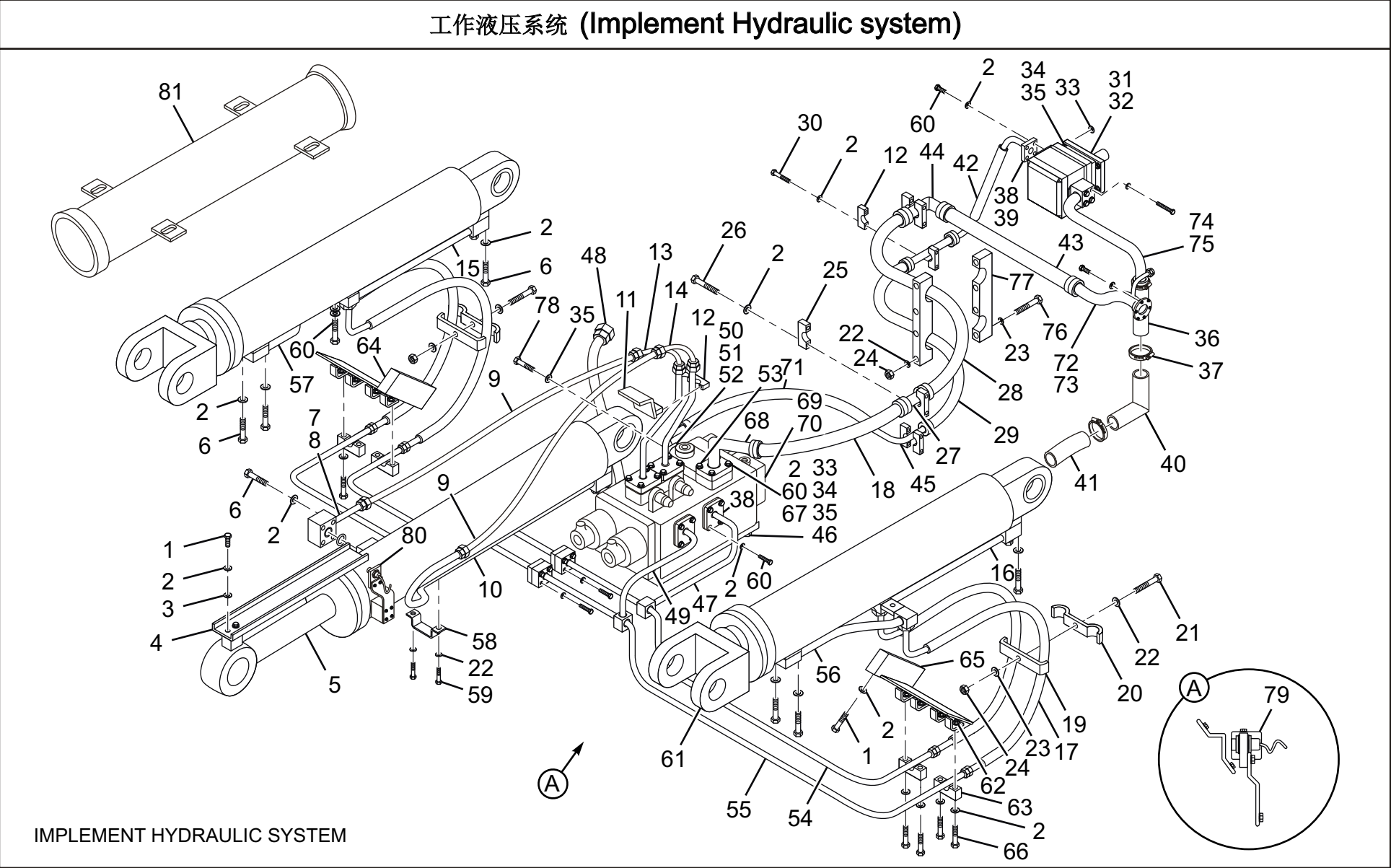

IMPLEMENT HYDRAULIC SYSTEM

Figure 22

工作液压系统 Implement Hydraulic System						
Item	Parts number	Chinese Description	English Description	Specification	Qty	Remarks
1	GB/T5783-2000	螺栓	Bolt	M10X20	6	8.8
2	GB/T93-1987	垫圈	Washer	10	84	
3	GB/T97.1-2002	垫圈	Washer	10	4	
4	CDM860.07.09	转斗油缸保护装置	Tilt cylinder guard device		1	
5	CDM860.07.01A	转斗油缸	Tilt cylinder	110X220X626	1	
6	GB/T5782-2000	螺栓	Bolt	M10X70	24	8.8
7	GB/T3452.1-2005	O 形圈	O-ring	32.5X3.55	6	
8	LG855.07.03	转斗油缸前腔钢管	Front chamber pipe of tilt cylinder		1	
9	20411-36T/20441-36T *2N16*1250	分配阀至转斗缸胶管	Hose from distribution valve to tilt cylinder		2	
10	LG860.07.10	转斗油缸后腔钢管	Rear chamber pipe of tilt cylinder		1	
11	LG855.07.25	钢管固定架	Pipe fixed plate		2	
12	LG853.07-002	压板	Press plate		4	
13	CDM860.07.05	多路阀至转斗大腔钢管	Big chamber pipe from distribution valve to tilt Small chamber pipe from distribution valve		1	
14	CDM860.07.06	多路阀至转斗小腔钢管	to tilt		1	
15	LG855.07.07	动臂油缸后腔钢管	Rear chamber pipe of lift cylinder		1	
16	LG855.07.08	动臂油缸后腔钢管	Rear chamber pipe of lift cylinder		1	

Figure 22

工作液压系统 (Implement Hydraulic system)

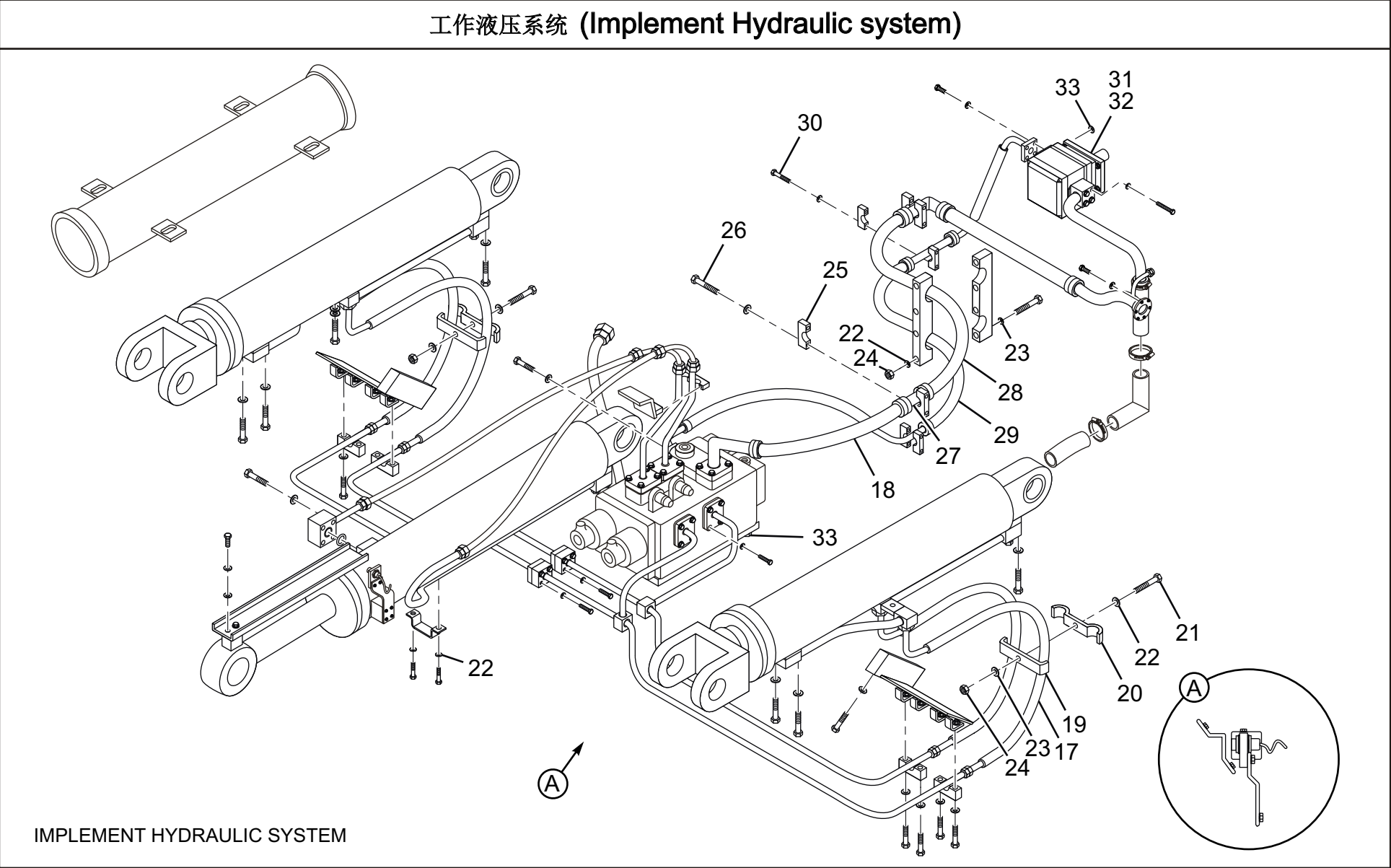
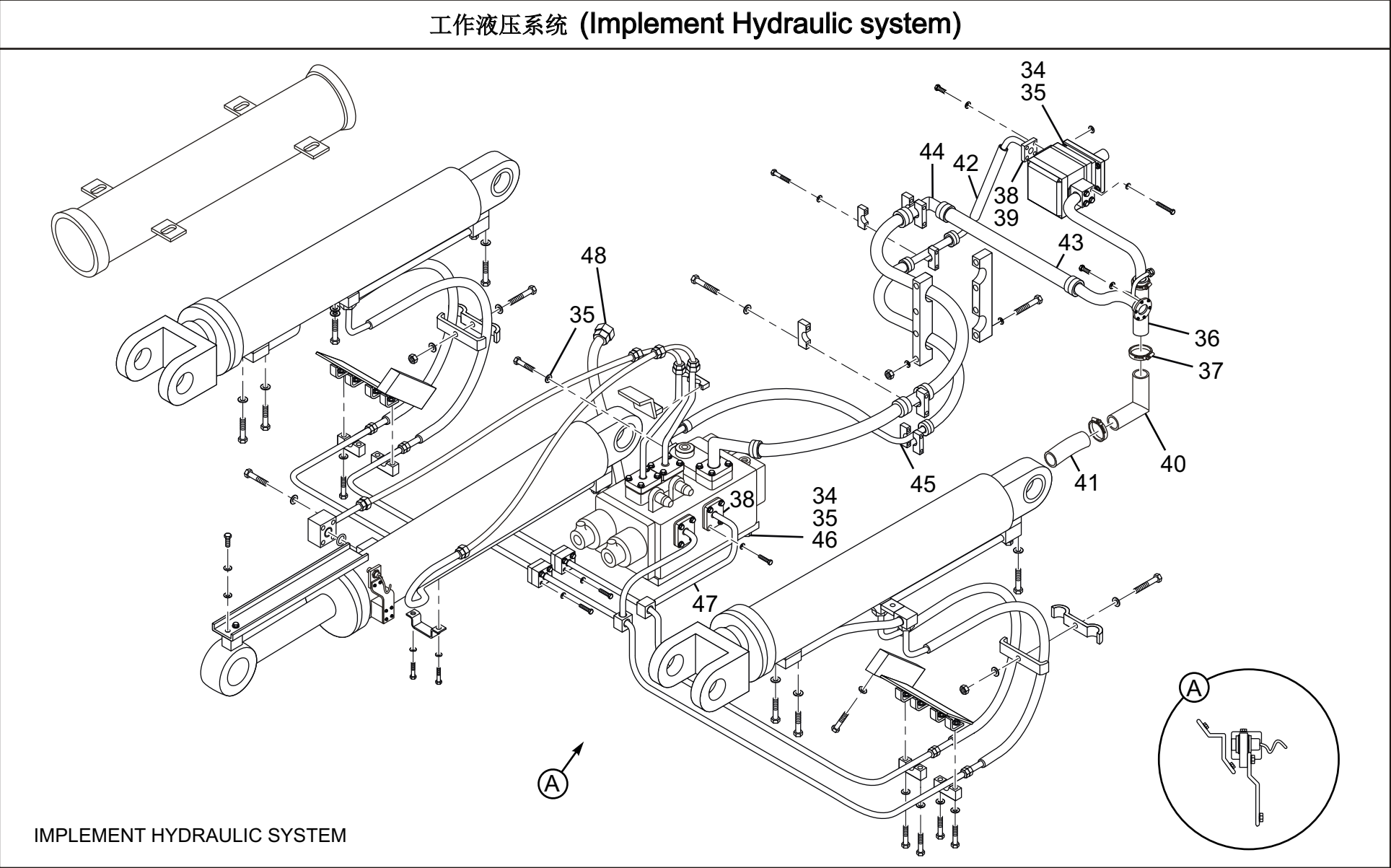

Figure 22

工作液压系统 Implement Hydraulic System						
Item	Parts number	Chinese Description	English Description	Specification	Qty	Remarks
17	20411-36T/20481-36T *2N16*1600	动臂缸胶管	Lift cylinder hose		4	
18	20411-52T*1W24*470	分配阀回油胶管	Distribution valve oil return hose		1	
19	LG855.07-001	管夹	Pipe clamp		2	
20	LG855.07-006	管夹压板	Pipe clamp press plate		4	
21	GB/T5783-2000	螺栓	bolt	M8X80	2	8.8
22	GB/T97.1-2002	垫圈	Washer	8	12	
23	GB/T93-1987	垫圈	Washer	8	4	
24	GB/T6170-2000	螺母	Nut	M8	12	8
25	LG853.07-004	压板	Press plate		2	
26	GB/T5782-2000	螺栓	Bolt	M10X50	4	8.8
27	LG855.07.09	回油过渡接头	Oil return transition connector		1	
28	20411-52T*1W24*1250	铰接回油胶管	Articulated oil return hose		1	
29	20411-36T*2N16*1250	铰接进油胶管	Articulated oil inlet hose		1	
30	GB/T5782-2000	螺栓	Bolt	M10X42	4	8.8
31	P7600-F125NM467 6G	齿轮泵	Gear pump		1	PERMCO
32	LG853.06-001	密封垫片	Seal gasket		1	
33	GB/T97.1-2002	垫圈	Washer	12	2	

Figure 22

工作液压系统 (Implement Hydraulic system)



IMPLEMENT HYDRAULIC SYSTEM

Figure 22

工作液压系统 Implement Hydraulic System						
Item	Parts number	Chinese Description	English Description	Specification	Qty	Remarks
34	GB/T6170-2000	螺母	Nut	M12	7	
35	GB/T93-1987	垫圈	Washer	12	15	
36	φ51X4-L520	吸油胶管	Oil suction hose		1	
37	JB/T8870-1999	喉箍	Hoop	φ51~70	4	
38	FL-20	法兰夹	Flange holder		7	
39	GB/T3452.1-2005	O 型圈	O-ring	37.5X3.55	7	
40	CDM860.06.04	吸油过渡钢管	Oil suction transition pipe		1	
41	φ51X4-L150	吸油胶管	Oil suction hose		1	
42	20411-36T/87341-20	工作泵出油胶管	Implement pump oil outlet hose		1	
43	*2N16*650					
	20411-52T*1W24*540	回油胶管	Oil return hose		1	
44	LG855.07.11	后车架回油过渡接头	Rear frame oil return transition connector		1	
45	LG860.07.07	前车架进油钢管	Front frame oil inlet pipe		2	
46	GB/T5782-2000	螺栓	Bolt	M12X180	3	8.8
47	LG860.07.08	分配阀动臂联后腔钢管 (一)	Pipe from distribution valve to lift cylinder rear chamber I		1	
48	20411-36T/87341-16 *2N16*420	合流胶管	Combined flow hose		1	

Figure 22

工作液压系统 (Implement Hydraulic system)

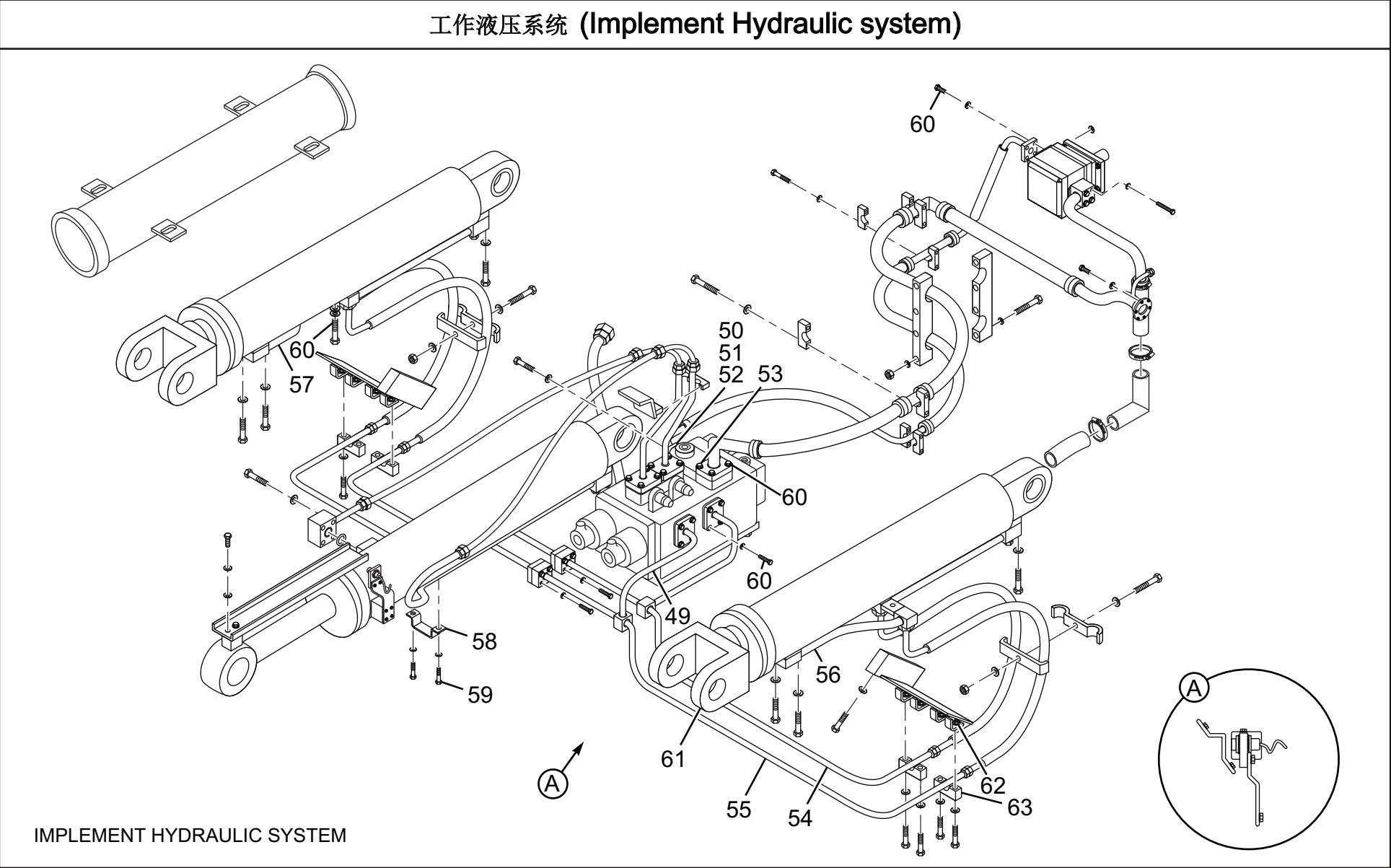

IMPLEMENT HYDRAULIC SYSTEM

Figure 22

工作液压系统 Implement Hydraulic System						
Item	Parts number	Chinese Description	English Description	Specification	Qty	Remarks
49	LG50EX.07.07	分配阀动臂联前腔钢管 (一)	Pipe from distribution valve to lift cylinder Front chamber I		1	
50	LG860.07-001	压块	Press block		1	
51	GB/T3452.1-2005	O 形圈	O-ring	47.5X3.55	3	
52	FL-24	法兰夹	Flange holder		1	
53	GB/T5783-2000	螺栓	Bolt	M12X45	4	8.8
54	LG860.07.09	分配阀动臂联后腔钢管 (二)	Pipe from distribution valve to lift cylinder rear chamber II		1	
55	LG50EX.07.09	分配阀动臂联前腔钢管 (二)	Pipe from distribution valve to lift cylinder Front chamber II		1	
56	LG860.07.12	动臂油缸前腔钢管 (左)	Lift cylinder front chamber pipe (left)		1	
57	LG860.07.13	动臂油缸前腔钢管 (右)	Lift cylinder front chamber pipe (right)		1	
58	LG855.07-003	管夹	Pipe clamp		1	
59	GB/T5783-2000	螺栓	Bolt	M8X30	2	8.8
60	GB/T5783-2000	螺栓	Bolt	M10X35	28	8.8
61	CDM860.07.02	动臂油缸	Lift cylinder		2	
62	GB/T6170-2000	螺母	Nut	M10	8	8
63	LG50EX.07-005	管夹	Pipe clamp		4	

Figure 22

工作液压系统 (Implement Hydraulic system)

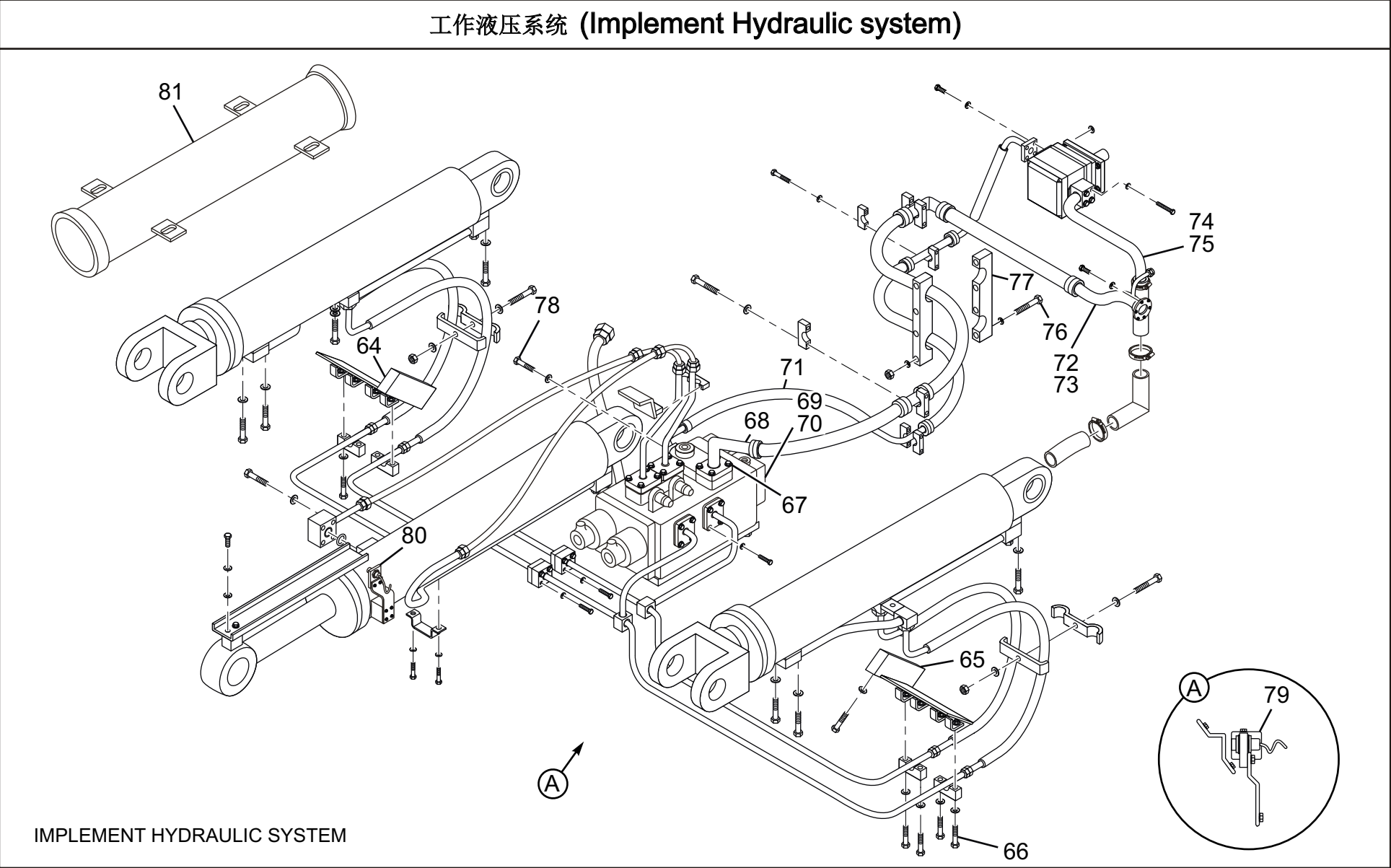

IMPLEMENT HYDRAULIC SYSTEM

Figure 22

工作液压系统 Implement Hydraulic System						
Item	Parts number	Chinese Description	English Description	Specification	Qty	Remarks
64	LG50EX.07.13	动臂钢管固定板	Lift arm pipe fixed plate		1	
65	LG50EX.07.14	动臂钢管固定板	Lift arm pipe fixed plate		1	
66	GB/T5782-2000	螺栓	Bolt	M10X60	8	8.8
67	FL-16	法兰夹	Flange holder		1	
68	LG50EX.07.10	分配阀回油钢管	Distribution valve oil return pipe		1	
69	D32	液控多路阀	Hydraulic control distribution valve		1	
70	LG860.07.11	先导操纵系统	Pilot control system		1	
71	20411-36T/87391-24 *2N16*800	分配阀进油胶管	Distribution valve oil inlet hose		1	
72	GB/T3452.1-2005	O 形圈	O-ring	58X3.55	2	
73	LG860.07.05	液压系统回油钢管	Hydraulic system oil return pipe		1	
74	CDM860.07.03	工作泵吸油钢管	Implement pump oil suction pipe		1	
75	FL-32	法兰夹	Flange holder		2	
76	GB/T5782-2000	螺栓	Bolt	M8X130	4	8.8
77	LG860.07-002	外购管夹	Purchased pipe clamp		1	
78	GB/T5782-2000	螺栓	bolt	M12X100	4	8.8
79	LG862.07.02	动臂限位装置	Lift cylinder locating device		1	
80	CDM856E.07 I .07	自动放平装置	Automatic level device		1	

Figure 22

工作液压系统 (Implement Hydraulic system)

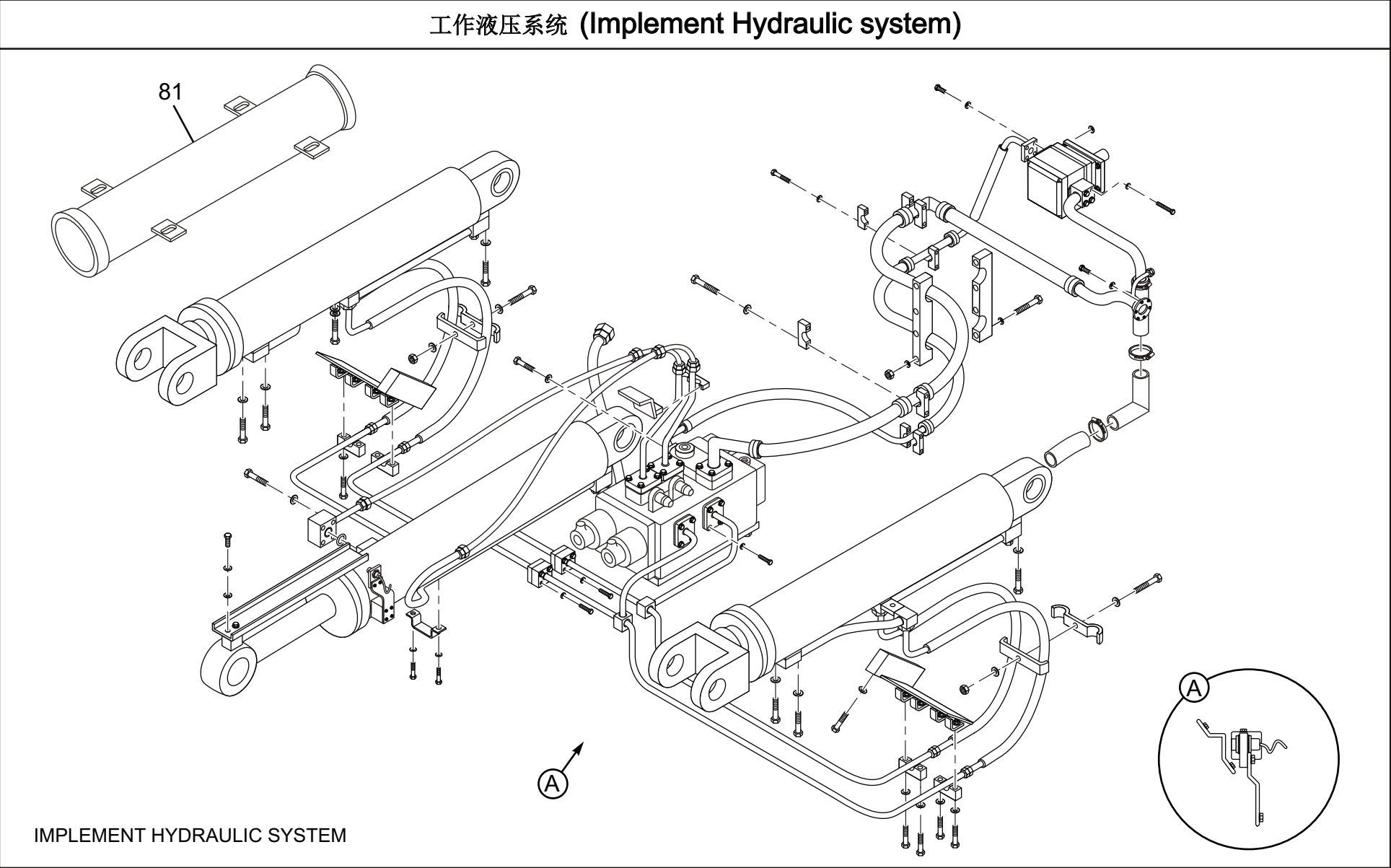

IMPLEMENT HYDRAULIC SYSTEM

Figure 22

工作液压系统 Implement Hydraulic System						
Item	Parts number	Chinese Description	English Description	Specification	Qty	Remarks
81	CDM856E.07 I .03	动臂油缸支撑架	Lift cylinder carriage		2	

先导操纵系统 Pilot Control System

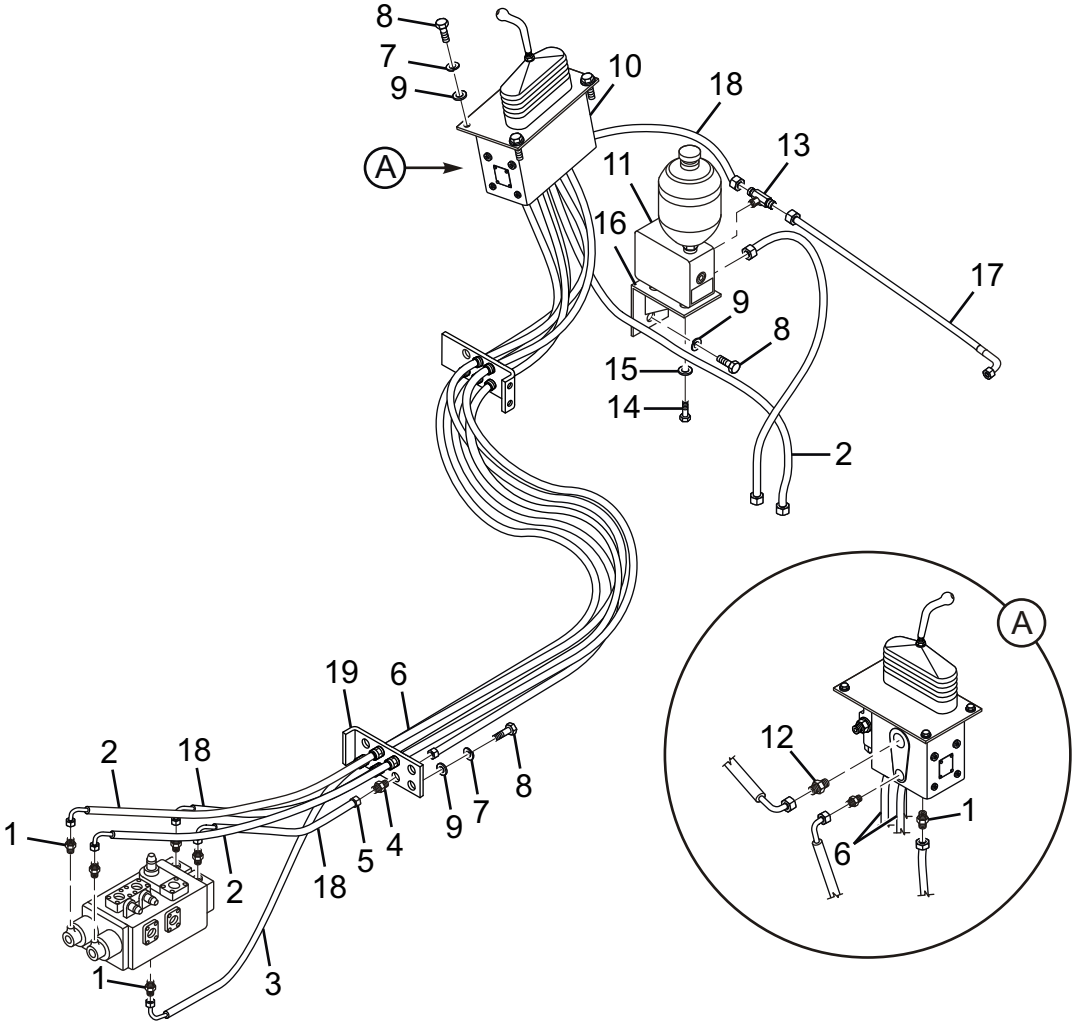

PILOT CONTROL SYSTEM

Figure 23

先导操纵总成 Pilot Control System						
Item	Parts number	Chinese Description	English Description	Specification	Qty	Remarks
1	L1DH-16-14	接头体	Adapter		13	
2	20591-16/20511-16* 1W05*1152	胶管总成	Hose assembly		5	
3	20591-16/20511-16* 1W05*800	胶管总成	Hose assembly		1	
4	L6D-16	隔板接头	Adapter		10	
5	L8C-16	隔板螺母	Nut		10	8
6	20511-16*1W05*1152	胶管总成	Hose assembly		9	
7	GB/T97.1-2002	垫圈	Washer	10	8	
8	GB/T5783-2000	螺栓	Bolt	M10X25	11	
9	GB/T93-1987	垫圈	washer	10	11	
10	DXS-00	单手柄先导操纵阀	Single handle pilot control valve		1	
11	WYF-65	供油阀	Oil supply valve		1	枫阳
12	L1CH-20GB-18	先导回油接头	Pilot oil return connector		1	
13	LADDH-16-16-14OG	三通接头	T-connector		1	
14	GB/T5783-2000	螺栓	Bolt	M8X20	2	8.8
15	GB/T93-1987	垫圈	Washer	8	2	
16	LG50EX.07.11.03	供油阀安装支架	Oil supply valve mounting bracket		1	借用

先导操纵系统 Pilot Control System

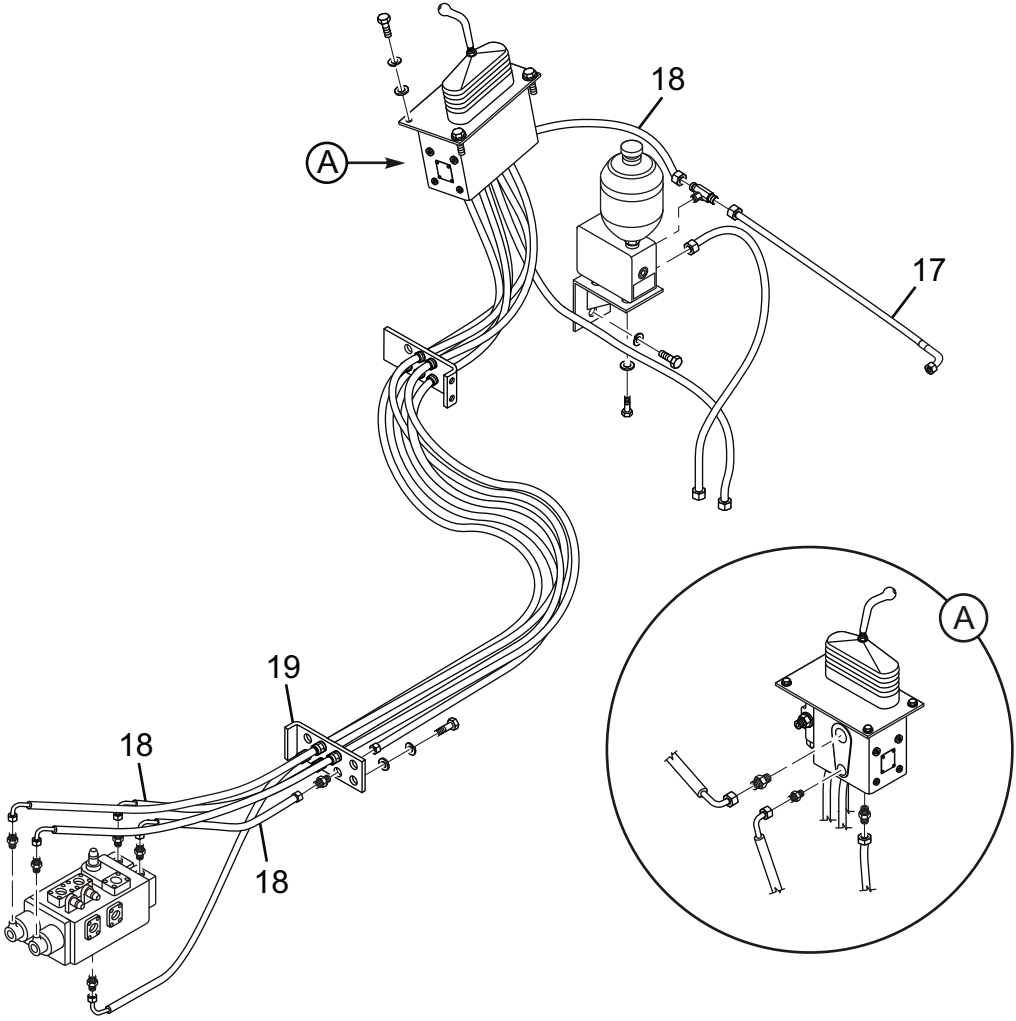

PILOT CONTROL SYSTEM

先导操纵总成 Pilot Control System						
Item	Parts number	Chinese Description	English Description	Specification	Qty	Remarks
17	20591-16*1W05*1000	供油阀进油胶管	Oil supply valve inlet hose		1	
18	20591-16/20511-16* 1W05*600	胶管总成	Hose assembly		3	
19	LG860.07.11-001	先导控制油管固定板	Pilot control oil pipe fixed plate		2	

Figure 24

脚制动系统 Service Brake System

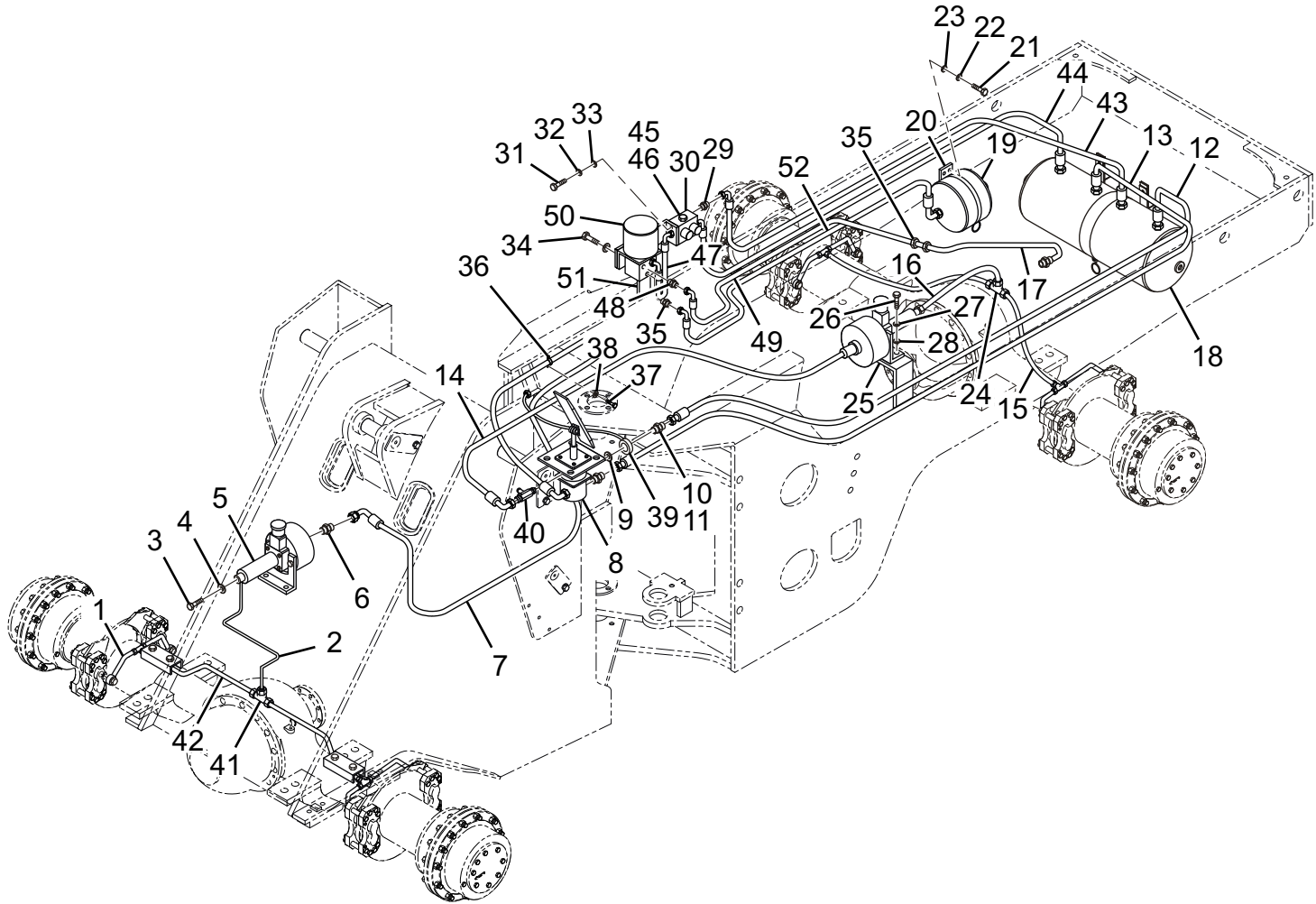

SERVICE BRAKE SYSTEM

Figure 24

脚制动系统 Service Brake System						
Item	Parts number	Chinese Description	English Description	Specification	Qty	Remarks
1	LG860.08.01	进油管	Oil inlet hose		4	
2	LG853.08.03	前加力泵出油管	Front booster oil outlet pipe		2	
3	700M-12	铰接螺栓	Articulated bolt		10	
4	JB/T982-1977	垫圈	Washer	12	11	
5	LG856.08.02	加力泵	Booster pump		2	HP3.5-90
6	L1QH-16-22	接头	Adapter		10	
7	90C-C/8/8-I-L3200	制动阀至前加力泵胶管	Hose from brake valve to front booster pump		1	
8	LG856.08.07	双腔气制动阀	Dual-chamber air brake valve		1	HP3514B
9	JB/T982-1977	垫圈	Washer	22	13	
10	LG853.08-007	测压接头座	Pressure connector seat		1	
11	LG853.08-006	进气接头	Air inlet connection		1	
12	90C-C/8/8-I-L3900	制动阀至右储气筒胶管	Hose from brake valve to right air tank		1	
13	90C-C/8/8-I-L3600	制动阀至左储气筒胶管	Hose from brake valve to left air tank		1	
14	90C-C/8/8-I-L1400	制动阀至后加力泵胶管	Hose from brake valve to rear booster pump		1	
15	LG853.08.06	后桥油管	Rear axle oil pipe		2	
16	LG853.08.11	制动软管	Brake hose		1	

Figure 24

脚制动系统 Service Brake System

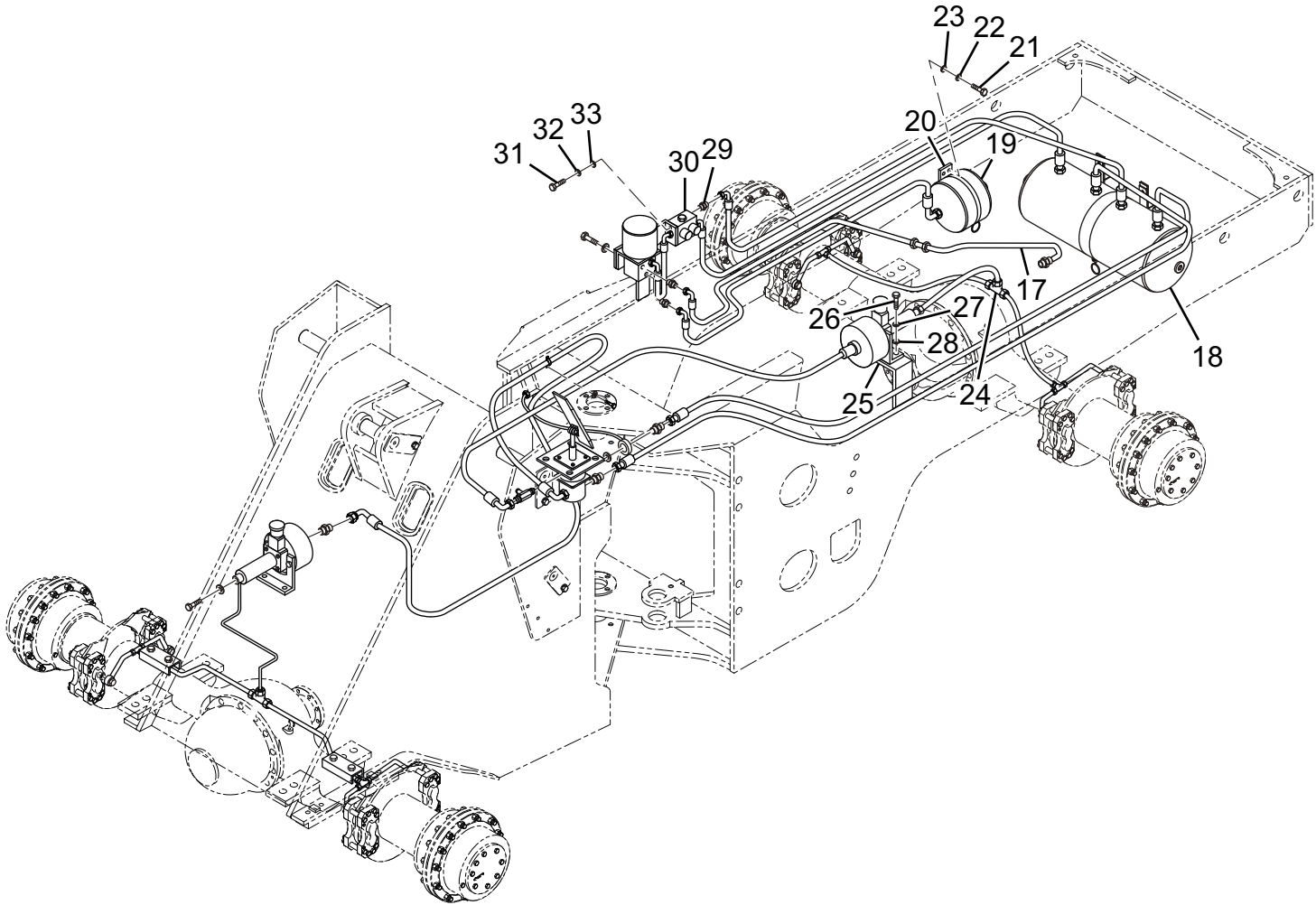

SERVICE BRAKE SYSTEM

Figure 24

脚制动系统 Service Brake System						
Item	Parts number	Chinese Description	English Description	Specification	Qty	Remarks
17	LG853.08.07	气泵至卸荷阀气管	Hose from air pump to relief valve		1	
18	LG856.08.01	储气筒总成	Air tank assembly		1	
19	LG856.08.03	反冲储气筒	Anti-inflatable tank		1	HP-3511CB-18
20	LG856.08-005	反充气筒固定板	Anti-inflatable tank fixed plate		1	
21	GB/T5783-2000	螺栓	Bolt	M10X20	6	
22	GB/T93-1987	垫圈	Washer	10	6	
23	GB/T97.1-2002	垫圈	Washer	10	6	
24	LG853.08-014	后桥油路三通接头	Rear axle oil channel T connector		1	
25	LG855.08.01	后加力泵支座	Rear booster pump support		1	
26	GB/T5783-2000	螺栓	Bolt	M12X30	4	8.8
27	GB/T93-1987	垫圈	Washer	12	7	
28	GB/T97.1-2002	垫圈	Washer	12	7	
29	LG856.08-001	四回路保护阀出气接头	Four circuit protection valve air outlet connector		2	
30	LG856.08.04	四回路保护阀	Four circuit protection valve		1	HP3518
31	GB/T5783-2000	螺栓	Bolt	M8X20	9	8.8
32	GB/T93-1987	垫圈	Washer	8	9	
33	GB/T97.1-2002	垫圈	Washer	8	9	

脚制动系统 Service Brake System

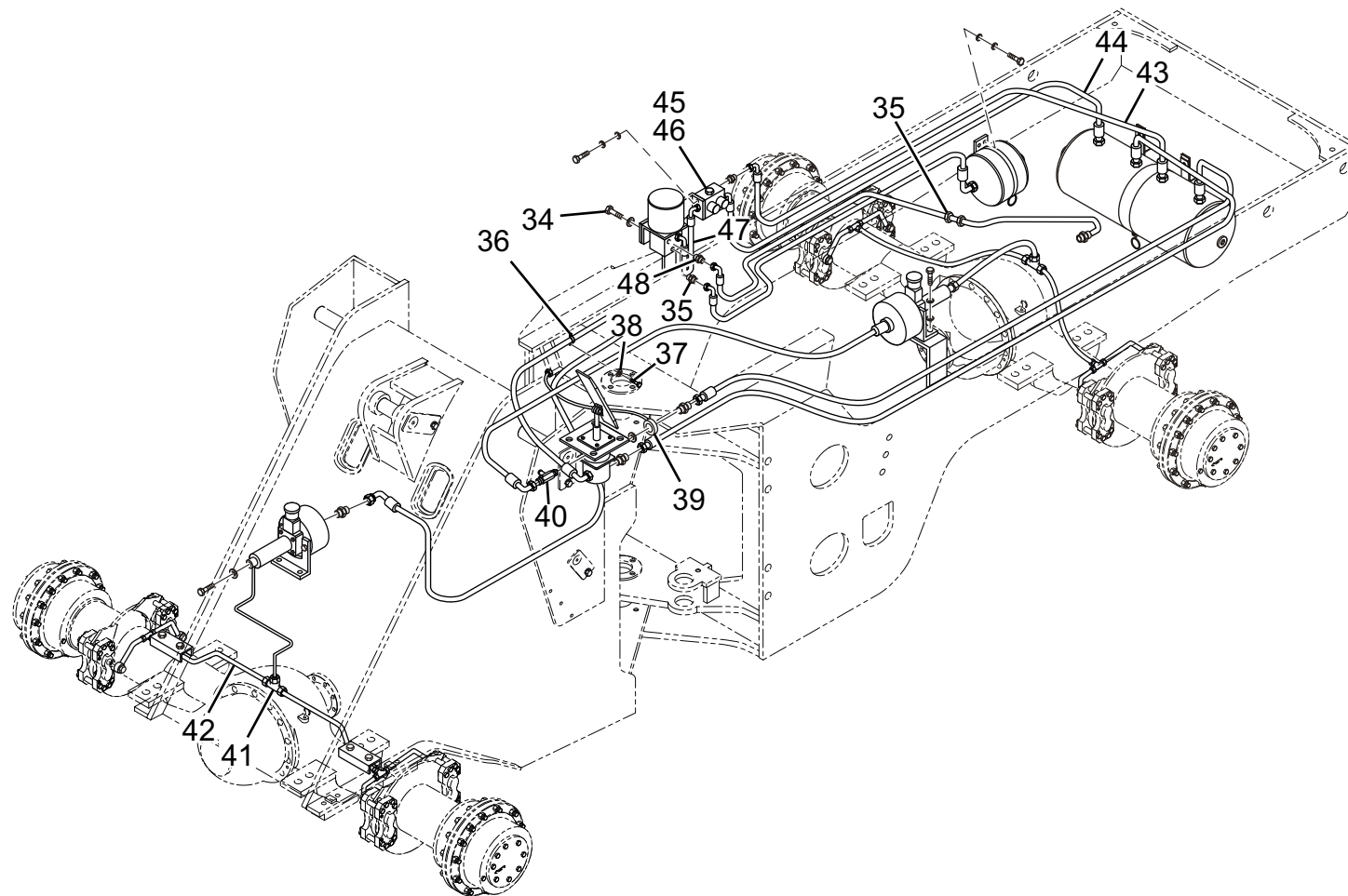

SERVICE BRAKE SYSTEM

Figure 24

脚制动系统 Service Brake System						
Item	Parts number	Chinese Description	English Description	Specification	Qty	Remarks
34	GB/T5786-2000	螺栓	Bolt	M12X1.5X30	3	8.8
35	L1QH-18-22	接头	Connector		2	
36	LG853.01-005	线夹	Wire clip		3	
37	GB/T5783-2000	螺栓	Bolt	M6X16	3	
38	GB/T93-1987	垫圈	Washer	6	3	
39	LG853.01-002	测压接头	Pressure connector		1	
40	LG853.08-008	制动灯开关三通接头	Brake lamp switch T-connector		1	
41	LG853.08-012	前桥油路三通接头	Front axle oil channel T-connector		1	
42	LG853.08.05	前桥油管	Front axle oil pipe		2	
43	90C-C/8/8-I-L1800	保护阀至右气筒胶管	Hose from protection valve to right air tank		1	
44	90C-C/8/8-I-L2100	保护阀至左气筒胶管	Hose from protection valve to left air tank		1	
45	JB/T982-1977	垫圈	washer	16	3	
46	L4H-16	堵头	Plug		1	
47	90C-90°-90C/8/8-I-L450	干燥器至保护阀胶管	Hose from drier to protection valve		1	
48	L1QH-16-12	接头	Connector		1	

脚制动系统 Service Brake System

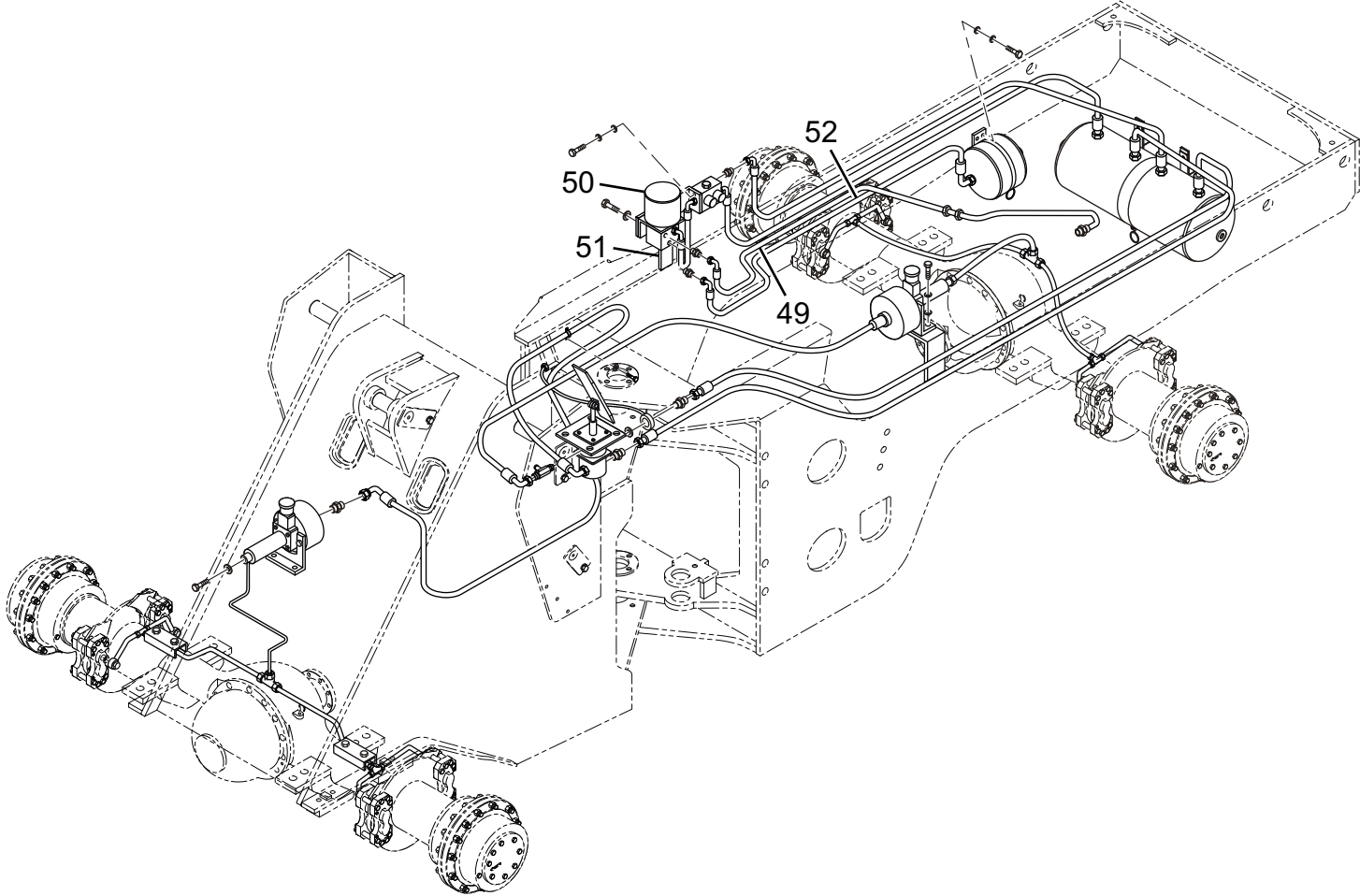

SERVICE BRAKE SYSTEM

脚制动系统 Service Brake System						
Item	Parts number	Chinese Description	English Description	Specification	Qty	Remarks
49	20791-18/20711-18 *JS805*1600	空压机至干燥器钢丝 软管	Wired hose from compressor to drier		1	耐高温管
50	LG856.08.05	干燥器	Drier		1	Hp3511
51	LG856.08.06	干燥器支架	Drier bracket		1	
52	90C-90°-90C/8/8-I -L1800	干燥器至反冲气筒 胶管	Hose from drier to recoil air tank		1	

Figure 25

手制动系统 Emergency and Parking Brake System

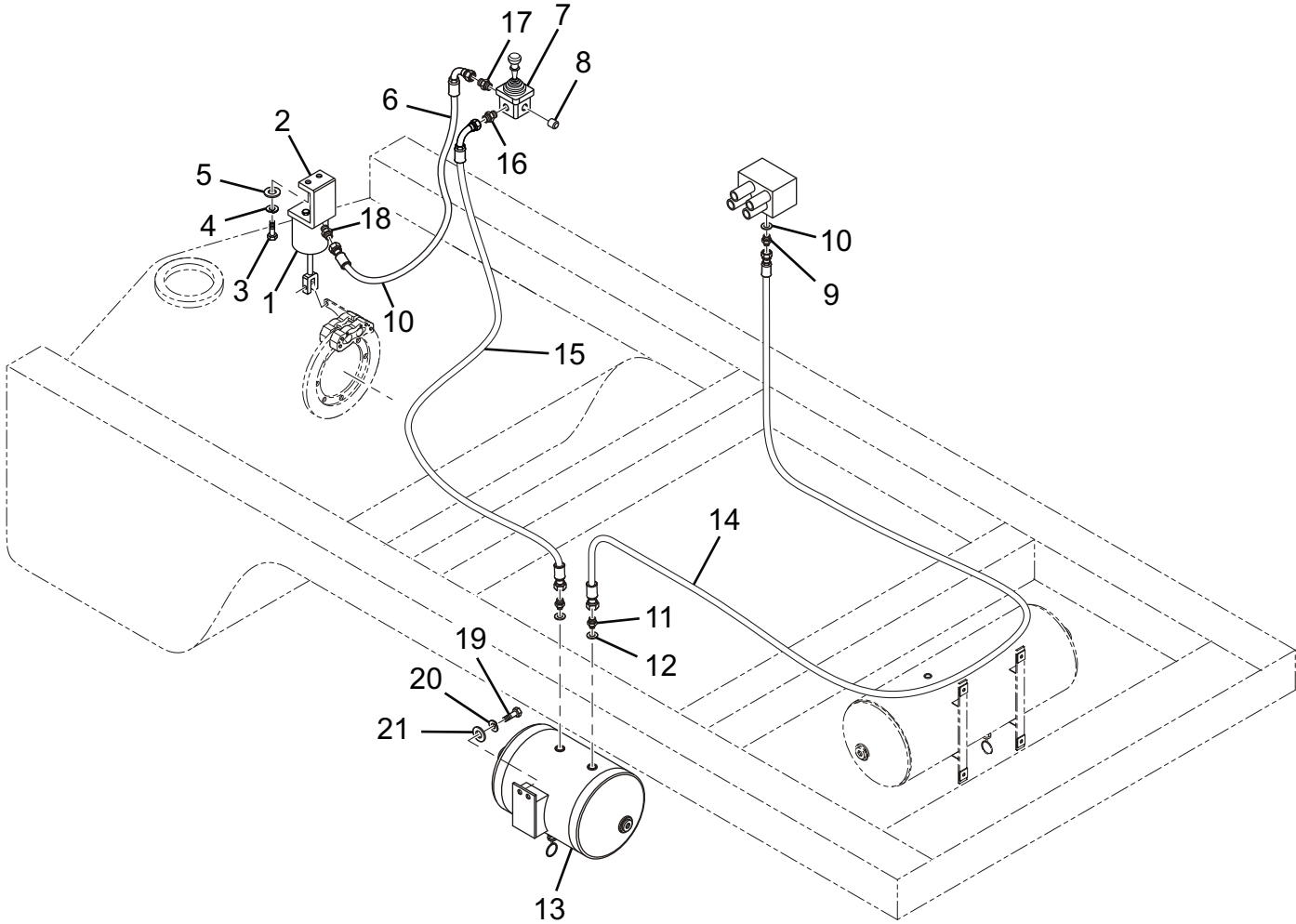

EMERGENCY AND PARKING BRAKE SYSTEM

手制动系统 Emergency and Parking Brake System						
Item	Parts number	Chinese Description	English Description	Specification	Qty	Remarks
1	LG50EX.09.02	驻车制动气室	Parking brake chamber		1	外购 QZ50-3507001
2	LG860.09.01	驻车制动气室固定支架	Parking brake chamber securing bracket		1	8.8
3	GB/T5783-2000	螺栓	Bolt	M16X45	2	
4	GB/T97.1-2002	垫圈	Washer	16	2	
5	GB/T93-1987	垫圈	Washer	16	2	
6	90C-C/8/8-I-L1800	手控制动阀至驻车制动气室胶管	Hose from manual brake valve to parking brake chamber		1	
7	LG856.09.02	手控制动阀	Manual brake valve		1	外购 Qz50
8	LG856.09-001	堵头	Plug		1	
9	L1QH-16	接头	Connector		1	
10	JB/T982-1977	垫圈	Washer	16	1	
11	L1QH-16-22	接头	Connector		2	
12	JB/T982-1977	垫圈	Washer	22	2	
13	LG856.09.01	驻车制动储气筒总成	Parking brake air tank assembly		1	
14	C-C/8/8-I-L3200	四回路保护阀至手制动气筒胶管	Hose from four circuit protection valve to parking brake air tank		1	

Figure 25

手制动系统 Emergency and Parking Brake System

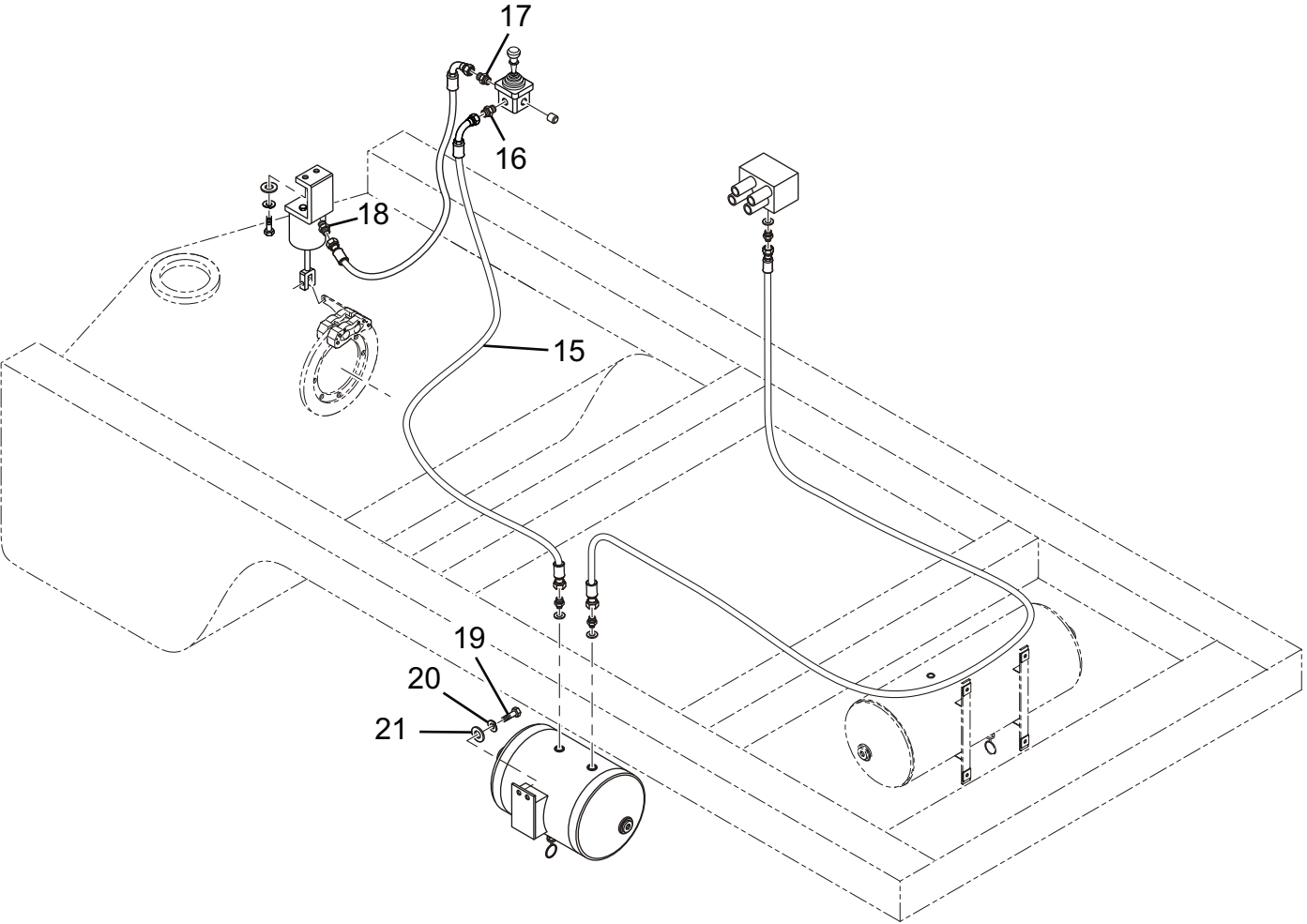

EMERGENCY AND PARKING BRAKE SYSTEM

Figure 25

手制动系统 Emergency and Parking Brake System						
Item	Parts number	Chinese Description	English Description	Specification	Qty	Remarks
15	C-C/8/8-I-L3200	手制动气筒至手控阀 胶管	Hose from manual brake air tank to manual brake valve		1	
16	LG50EX.09-002	手控制动阀进气接头	Manual brake valve air inlet connector		1	
17	LG50EX.09-001	手控制动阀出气接头	Manual brake valve air outlet connector		1	
18	L1QH-16-12	接头	Connector		1	
19	GB/T5783-2000	螺栓	Bolt	M10X20	2	8.8
20	GB/T97.1-2002	垫圈	Washer	10	2	
21	GB/T93-1987	垫圈	Washer	10	2	

Figure 26

车架系统 Frame System

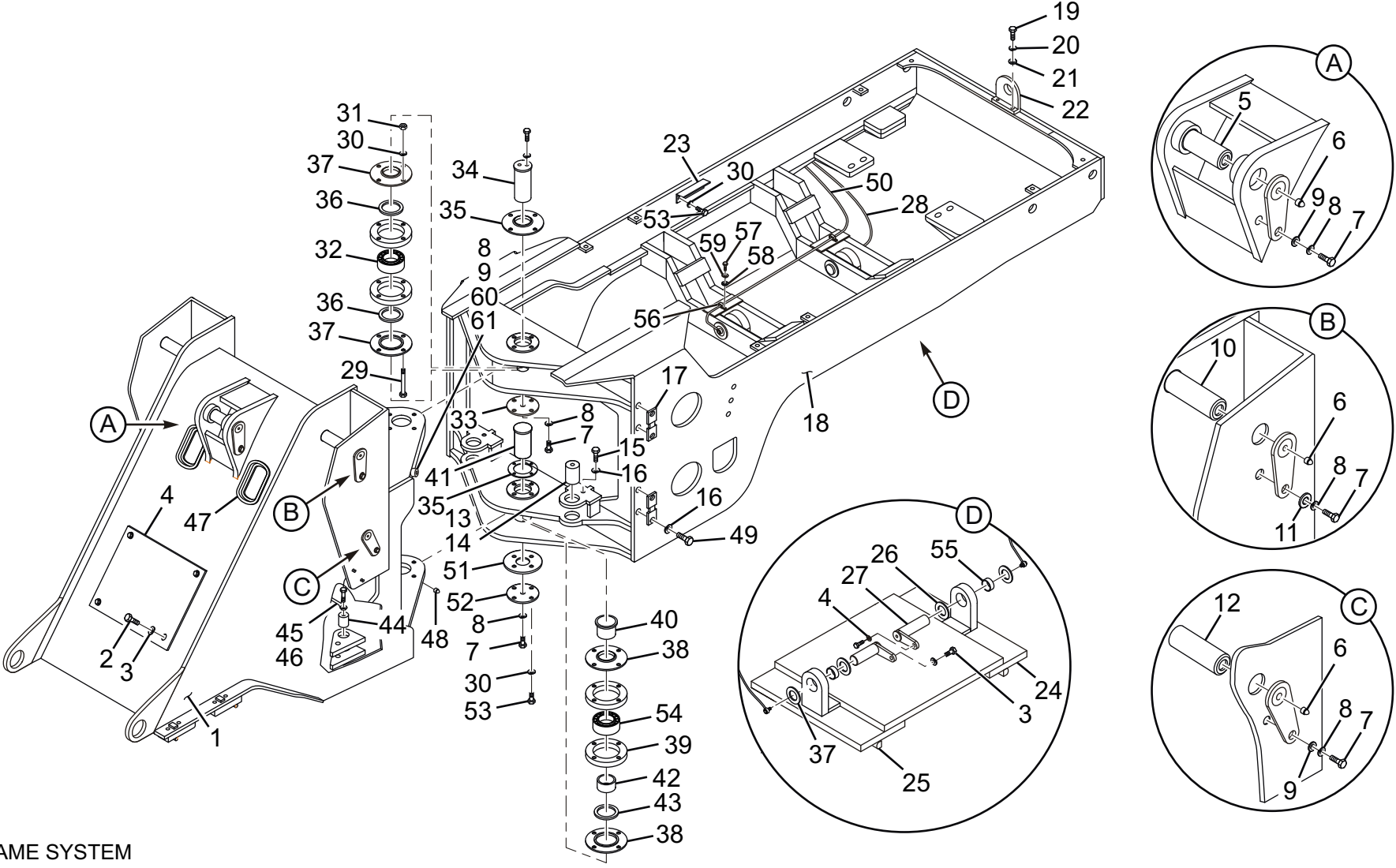

FRAME SYSTEM

Figure 26

车架系统 Frame System						
Item	Parts number	Chinese Description	English Description	Specification	Qty	Remarks
1	CDM860.10.01	前车架	Front frame		1	
2	GB/T5783-2000	螺栓	Bolt	M10×20	4	8.8
3	GB/T93-1987	垫圈	Washer	10	4	
4	LG860.10.07	盖板总成	Cover board assembly		1	
5	LG853.10.03	翻斗缸后销轴焊合	Tilt cylinder rear pin weldment		1	
6	JB/T7940.1-1995	油杯	Oil cup	M10×1	11	
7	GB/T5783-2000	螺栓	Bolt	M20×35	9	8.8
8	GB/T93-1987	垫圈	Washer	20	11	
9	GB/T97.1-2002	垫圈	Washer	20	7	
10	LG860.10.05	动臂上销轴焊合	Lift arm upper pin weldment		2	
11	LG855.10 I -001	垫板	Tie plate		2	
12	LG860.10.06	动臂缸后销轴焊合	Lift cylinder rear pin weldment		2	
13	LG855.10.07	后转向销轴焊合	Rear steering pin weldment		2	
14	LG855.10-002	转向缸后垫套	Steering cylinder rear crushion		2	
15	GB/T5783-2000	螺栓	Bolt	M16×35	4	8.8
16	GB/T93-1987	垫圈	Washer	16	12	
17	LG855.10.08	油箱固定座	Oil tank securing seat		2	
18	CDM860.10 I .02	后车架	Rear frame		1	

Figure 26

车架系统 Frame System

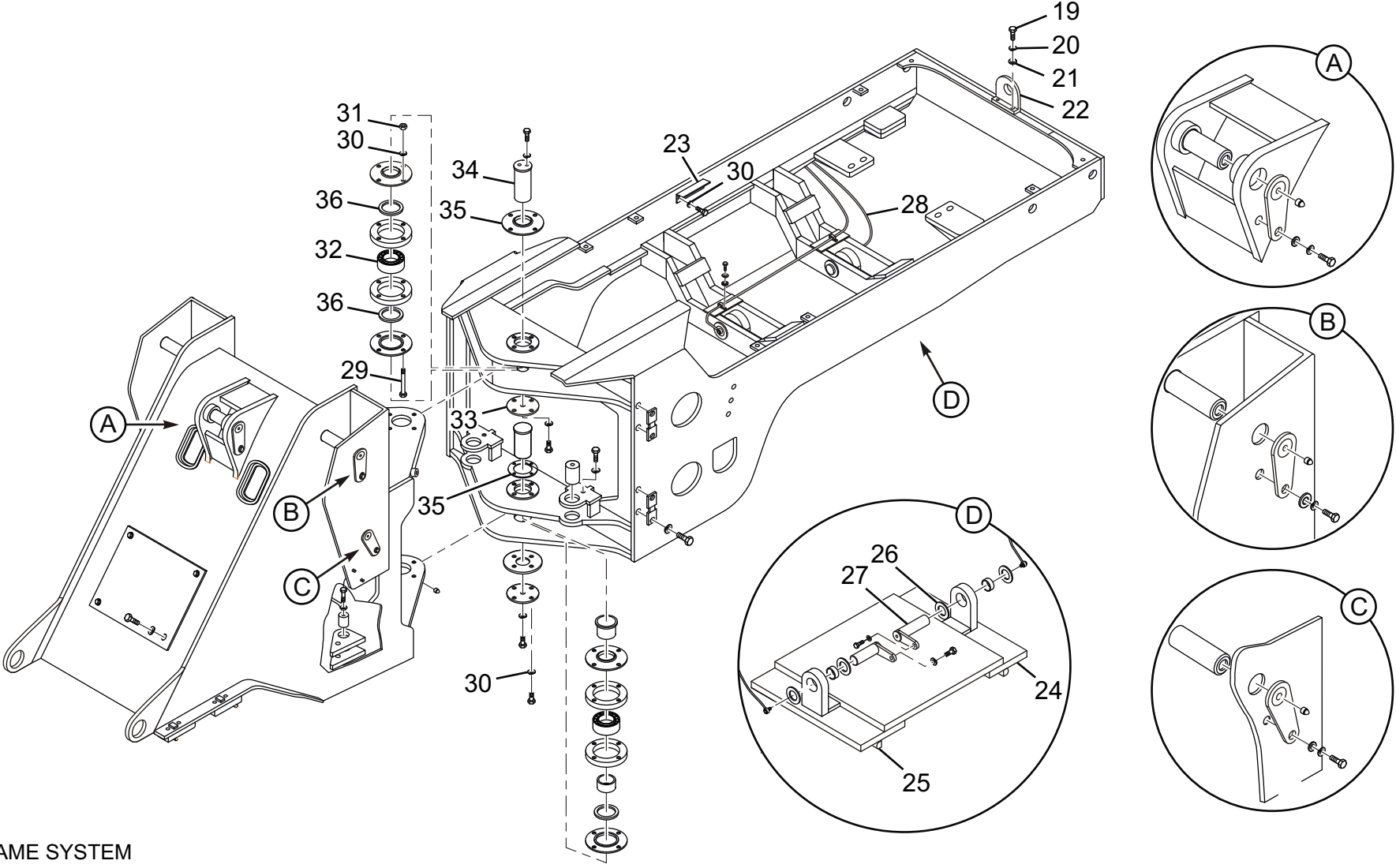

FRAME SYSTEM

Figure 26

车架系统 Frame System						
Item	Parts number	Chinese Description	English Description	Specification	Qty	Remarks
19	GB/T5783-2000	螺栓	Bolt	M6X25	2	8.8
20	GB/T97.1-2002	垫圈	Washer	6	2	
21	GB/T93-1987	垫圈	Washer	6	2	
22	CDM856E.10 I -002	电源总开关固定板	Main power switch fixed plate		1	
23	LG855.10-003	双变滤清器支架	Filter screen bracket		1	
24	LG860.10.03	副车架	Oscillating suspension		1	
25	LG853.10-018	挡块	Block		8	
26	LG855.10-004	铜垫	Copper pad		2	
27	LG855.10.09	副车架销	Oscillating suspension pin		2	
28	LG855.10.10	副车架注油管 1	Oscillating suspension oil filling pipe 1		1	
29	GB/T5782-2000	螺栓	Bolt	M12×110	16	8.8
30	GB/T93-1987	垫圈	Washer	12	22	
31	GB/T6170-2000	螺母	Nut	M12	8	8
32	GB/T297-1994	轴承	Bearing	32215	2	
33	LG853.10-008	端盖	End cover		1	
34	LG853.10-007	铰接销	Articulated pin		1	
35	LG853.10-006	压板	Press plate		2	
36	GB/T13871-2007	Fb 形油封	FB-type oil seal	75×100×12	2	

车架系统 Frame System

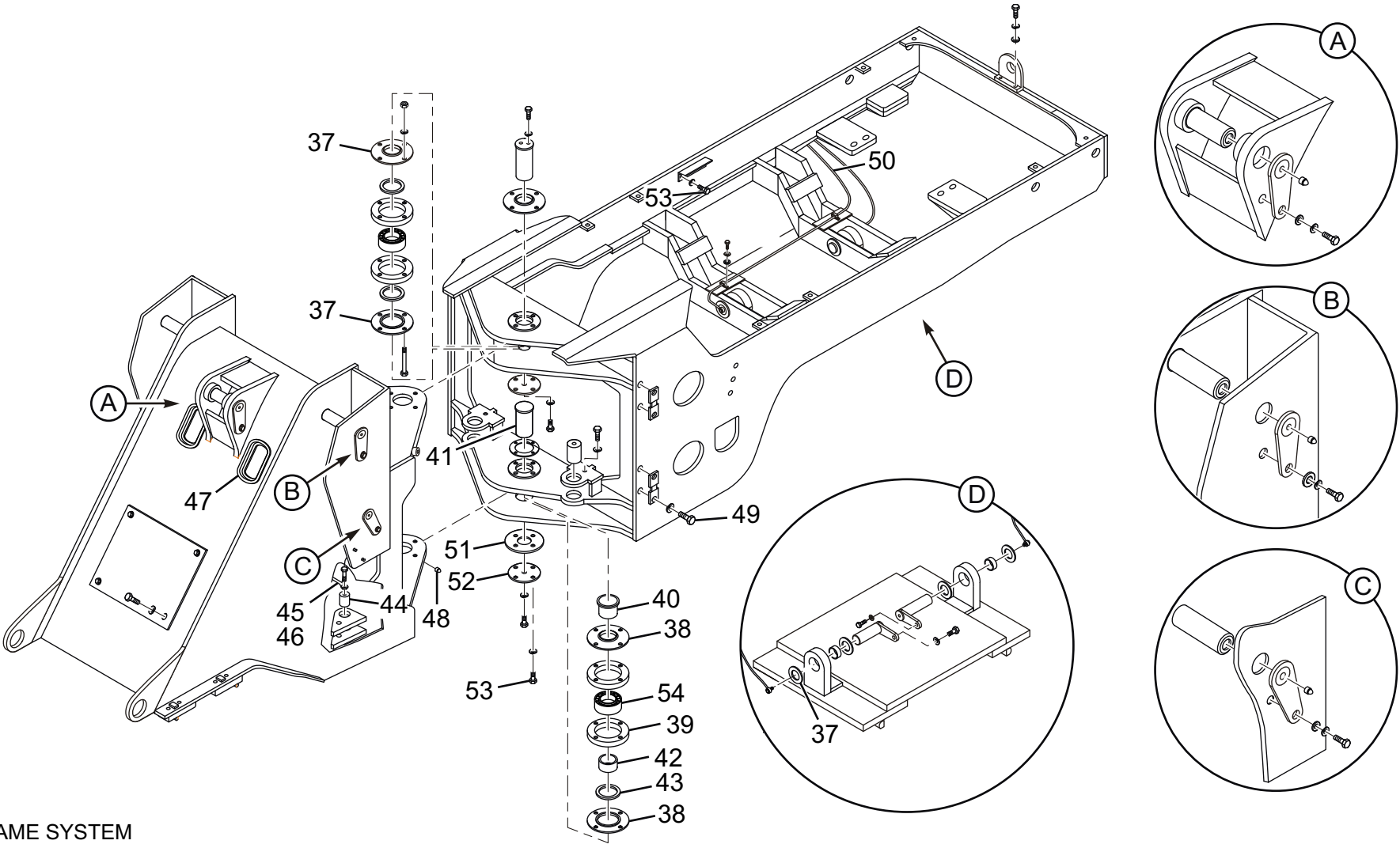

FRAME SYSTEM

Figure 26

车架系统 Frame System						
Item	Parts number	Chinese Description	English Description	Specification	Qty	Remarks
37	LG853.10 III -003	上轴承盖	Upper bearing cover		2	
38	LG853.10 III -002	下轴承盖	Lower bearing cover		2	
39	LG853.10 III -001	调整垫	Adjusting pad		二组	
40	LG860.10-004	上轴套	Upper shaft sleeve		1	
41	LG860.10-001	下铰接销	Lower articulated pin		1	
42	LG860.10-002	下轴套	Lower shaft sleeve		1	
43	GB/T13871-2007	FB 形油封	FB-type oil seal	85×110×12	2	
44	LG855.10.11	前转向销轴焊合	Front steering pin weldment		2	
45	LG860.10.12	右前转向销注油管	Right front steering pin oil filling pipe		1	
46	LG860.10.13	左前转向销注油管	Left front steering oil filling pipe		1	
47	LG860.10-003	胶管保护套	Hose sleeve		2	
48	JB/T7940.2-1995	油杯	Oil cup	M10×1	2	
49	GB/T5783-2000	螺栓	Bolt	M16×50	4	8.8
50	LG855.10.14	副车架注油管 2	Oscillating suspension oil filling pipe II		1	
51	LG855.10-006	调整垫圈	Adjusting washer		一组	
52	LG853.10-022	下端盖	Lower end cover		1	
53	GB/T5783-2000	螺栓	Bolt	M12×30	14	8
54	NTN	轴承	Bearing	NTN32215	2	

车架系统 Frame System

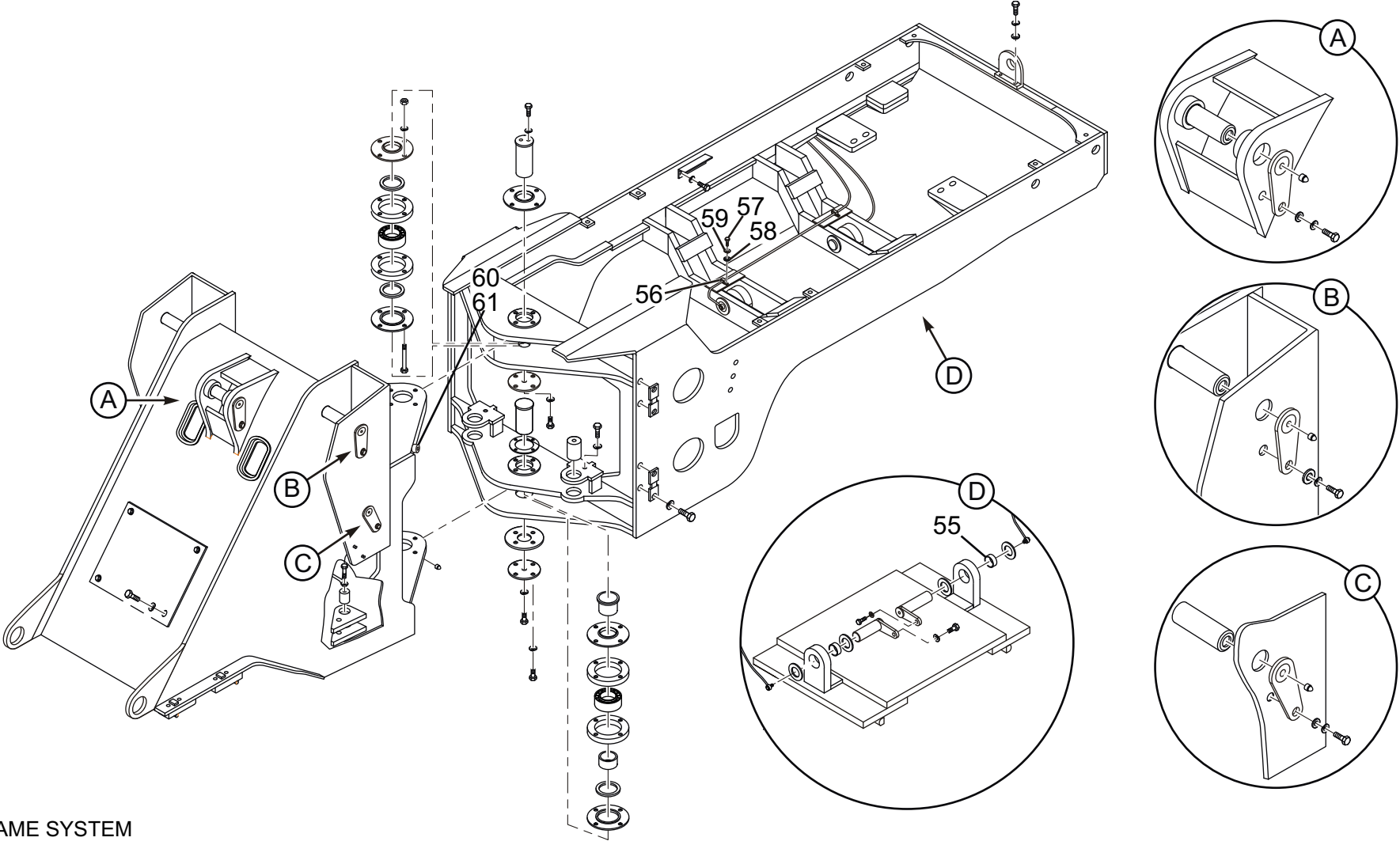

FRAME SYSTEM

Figure 26

车架系统 Frame System						
Item	Parts number	Chinese Description	English Description	Specification	Qty	Remarks
55	LG855.10-007	副车架销轴套	Oscillating suspension pin sleeve		2	
56	LG853.10-023	线夹	Wire clip		2	
57	GB/T5783-2000	螺栓	Bolt	M8×20	2	8.8
58	GB/T93-1987	垫圈	Washer	8	2	
59	GB/T97.1-2002	垫圈	Washer	8	2	
60	GB/5783-2000	螺栓	Bolt	M20×80	2	8.8
61	LG860.10.15	缓冲块	Bumper block		2	

Figure 27

工作装置系统 Implement system

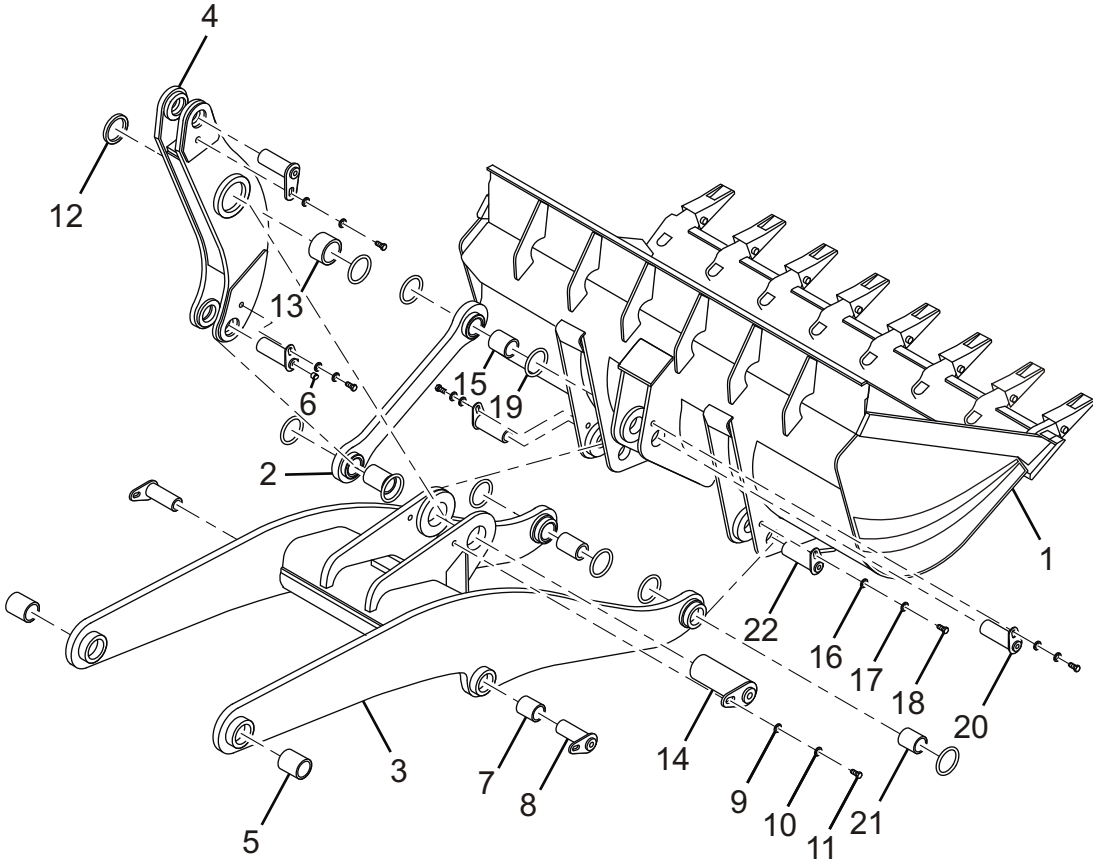

IMPLEMENT SYSTEM

Figure 27

工作装置系统 Implement system						
Item	Parts number	Chinese Description	English Description	Specification	Qty	Remarks
1	LG860.11.01	铲斗	Bucket		1	
2	LG860.11.02	拉杆	Pull rod		1	
3	CDM860.11.03	动臂	Lift arm		1	8.8
4	LG860.11.04	摇臂	Tilt arm	=	1	
5	CDM860.11-001	动臂上轴套	Lift upper pin sleeve		2	
6	JB/T7940.1	油杯	Oil cup	M10×1	8	8.8
7	CDM860.11-002	动臂缸上轴套	Lift cylinder upper pin sleeve		2	
8	LG860.11.05	动臂缸上销轴焊合	Lift cylinder upper pin weldment		2	
9	GB/T97.1	垫圈	Washer	24	1	
10	GB/T93	垫圈	Washer	24	1	
11	GB/T5783	螺栓	Bolt	M24×40	1	
12	GB9877.1-1988	油封	Oil seal	125×150×12	2	
13	CDM860.11-003	摇臂中轴套	Tilt arm middle shaft sleeve		2	
14	LG860.11.06	摇臂中销轴焊合	Tilt arm middle pin weldment		1	
15	CDM860.11-004	拉杆轴套	Pull rod bush		2	
16	GB/T93	垫圈	Washer	20	7	
17	GB/T97.1	垫圈	Washer	20	7	
18	GB/T5783	螺栓	Bolt	M20×40	7	

Figure 27

工作装置系统 Implement system

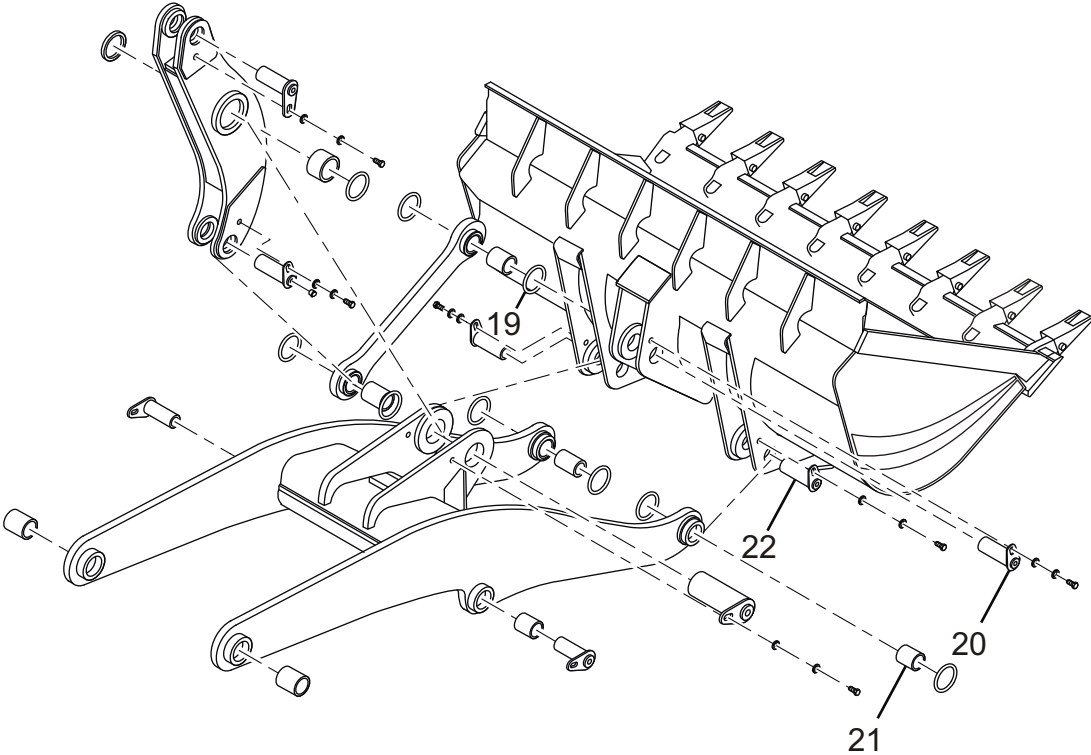

IMPLEMENT SYSTEM

Figure 27

工作装置系统 Implement system						
Item	Parts number	Chinese Description	English Description	Specification	Qty	Remarks
19	LG860.11-005	O 形密封圈	O-ring		8	
20	LG860.11.07	铲斗上销轴焊合	Bucket upper pin weldment		3	
21	CDM860.11-005	动臂下轴套	Lift arm lower shaft sleeve		2	
22	LG860.11.08	铲斗下销轴焊合	Bucket lower pin weldment		2	

Figure 28

驾驶室系统 Cab System

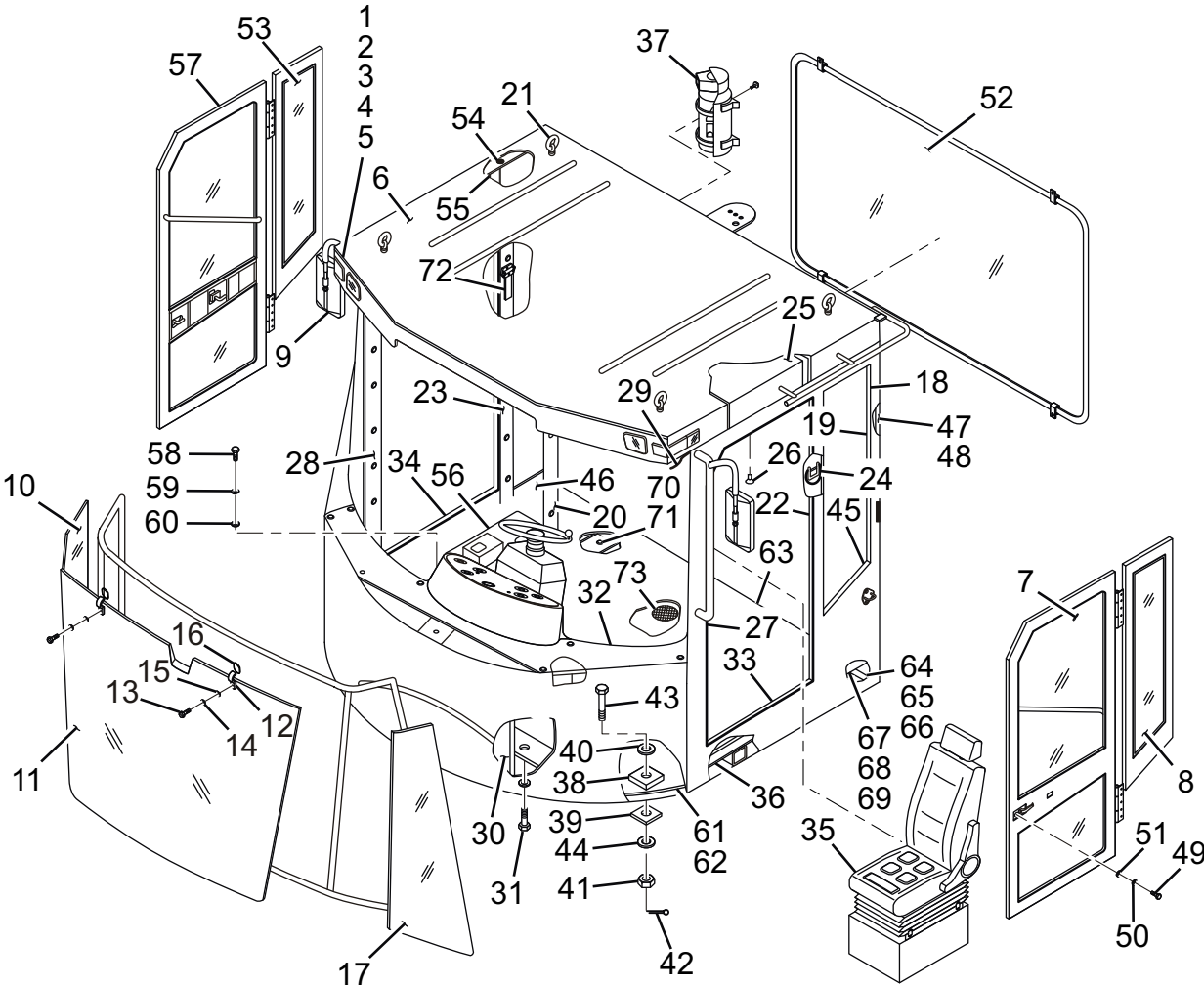

CAB SYSTEM

Figure 28

驾驶室系统 Cab System						
Item	Parts number	Chinese Description	English Description	Specification	Qty	Remarks
1	CDM856E.12 II .05	外顶灯前罩	Front lamp shade		1	
2	GB/T6170-2000	螺母	Nut	M6	9	8
3	GB/T96.2-2002	垫圈	Washer	6	9	
4	GB/T93-1987	垫圈	Washer	6	9	
5	GB/T5783-2000	螺栓	Bolt	M6X25	9	8.8
6	CDM856E.12 II .01	驾驶室	Cab		1	
7	CDM856E.12 II .03	左门	Left door		1	
8	CDM856E.12 II -001	左后侧玻璃	Left rear glass		1	
9	LG853.12.08	倒车镜	Rearview mirror		2	
10	LG863.12-003	右前侧玻璃	Right front glass		1	
11	LG863.12-001	前玻璃	Front glass		1	
12	LG853.12-002	玻璃压板	Glass press plate		8	
13	GB/T818-2000	螺钉	Screw	M5X10	16	8.8
14	GB/97.1-2002	垫圈	Washer	5	16	
15	GB/T93-1987	垫圈	Washer	5	16	
16	LG856.12-028	玻璃固定橡胶垫	Glass fixed rubber pad		8	
17	LG863.12-002	左前侧玻璃	Left front glass		1	
18	CDM856E.12 II -002	内顶衬	Roof lining		1	

Figure 28

驾驶室系统 Cab System

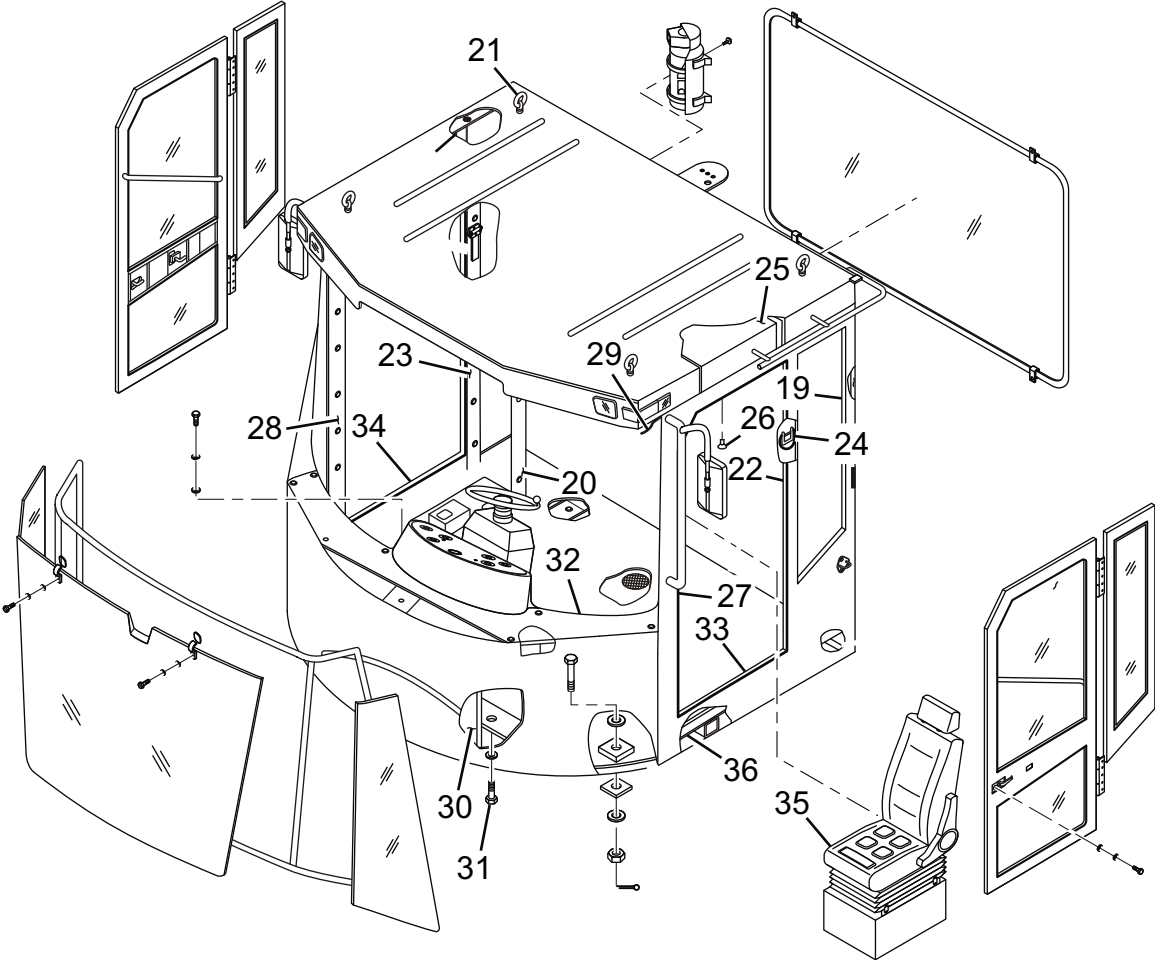

CAB SYSTEM

Figure 28

驾驶室系统 Cab System						
Item	Parts number	Chinese Description	English Description	Specification	Qty	Remarks
19	CDM856E.12 II -003	左后立柱	Left rear support		1	
20	CDM856E.12 II -004	右后立柱	Right rear support		1	
21	GB/T825-1988	吊环螺钉	Eye screw	M16	4	
22	CDM856E.12 II -006	左中立柱	Left middle support		1	
23	CDM856E.12 II -007	右后立柱	Right rear support		1	
24	LG856.12-019	衣帽勾	Hat-and-coat hook		1	
25	CDM856E.12 II -008	顶吸音海绵	Ceiling sound absorption sponge		1	
26	LG856.12-026	塑料铆钉	Plastic rivet		45	
27	CDM856E.12 II -009	左前立柱	Left front support		1	
28	CDM856E.12 II -010	右前立柱	Right front support		1	
29	LG30F.12-017	线束密封套	Wiring harness gland cover		2	
30	CDM856E.12 II -011	前吸音海绵	Front sound absorption sponge		1	
31	GB/T5783-2000	螺栓	Bolt	M16X60	10	8.8
32	CDM856E.12 II -012	仪表台下护板	Instrument platform down guard board		1	
33	CDM856E.12 II -013	左门下板	Left door lower board		1	
34	CDM856E.12 II -014	右门下板	Right door lower board		1	
35	CDM858A.12 I .07	司机座椅	Driver seat		1	
36	CDM856E.12 II -015	密封垫	Seal gasket		1	

驾驶室系统 Cab System

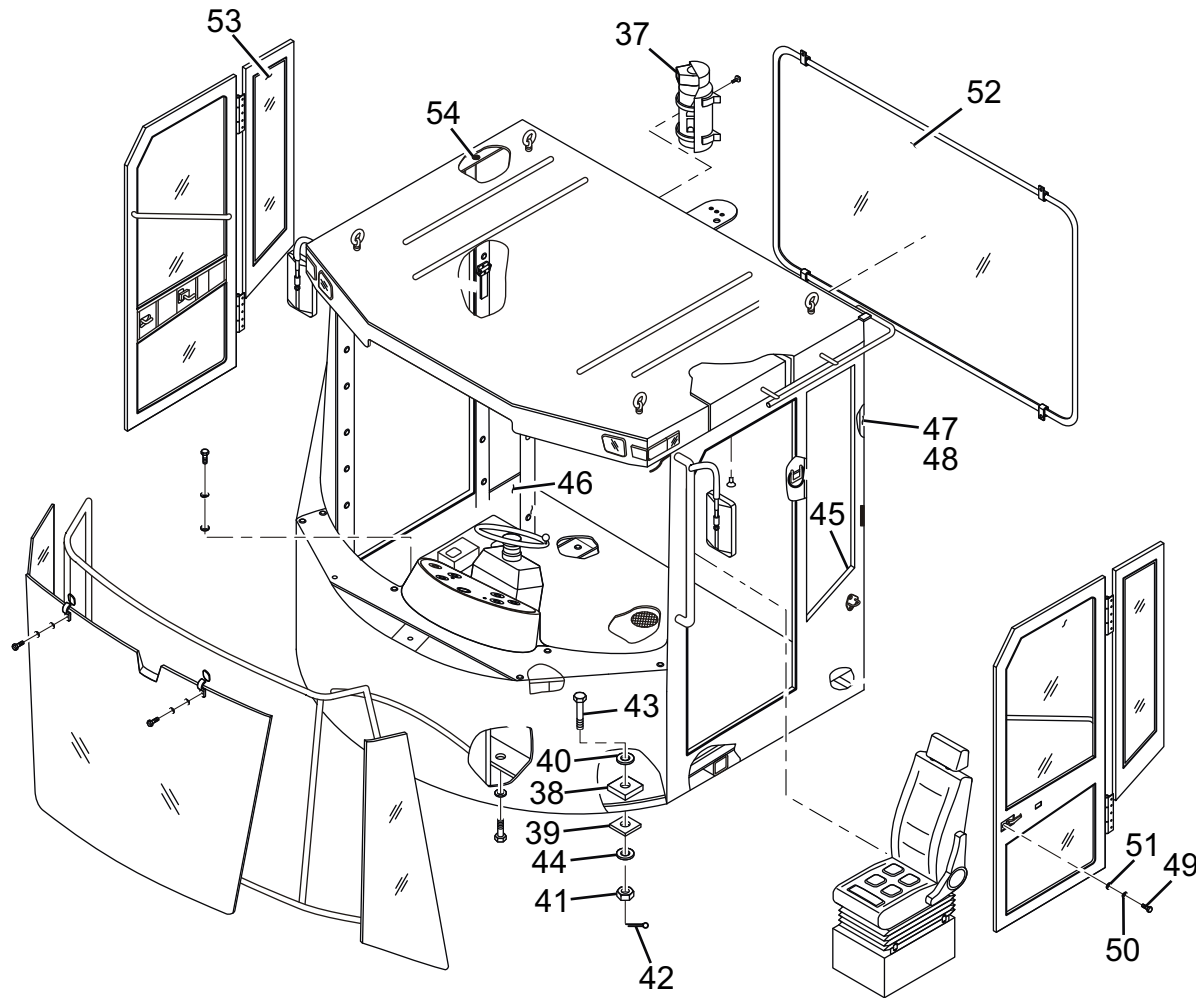

CAB SYSTEM

Figure 28

驾驶室系统 Cab System						
Item	Parts number	Chinese Description	English Description	Specification	Qty	Remarks
37	CDM858A.12 I .05	灭火器	Fire extinguisher		1	
38	LG853.12.05	橡胶垫	Rubber pad		4	
39	CDM856E.12 II -026	垫板	Tie plate		4	
40	LG855.12-009	垫圈	Washer		4	
41	GB/T9457-1986	螺母	Nut	M24X2	4	8
42	GB/T91-2000	开口销	Cotter pin	4X45	4	
43	GB/T31.3-1988	螺栓	Bolt	M24X2X170	4	8
44	GB/T96.1-2002	垫圈	Washer	24	4	
45	CDM856E.12 II -016	左后围板	Left rear boarding		1	
46	CDM856E.12 II -017	右后围板	Right rear boarding		1	
47	CDM856E.12 II -018	后围板	Rear boarding		1	
48	CDM856E.12 II -025	后吸音海绵	Rear sound absorption sponge		1	
49	GB/T5783-2000	螺栓	Bolt	M8X25	4	8.8
50	GB/T93-1987	垫圈	Washer	8	10	
51	GB/T97.1-2002	垫圈	Washer	8	10	
52	CDM856E.12 II -019	后玻璃	Rear glass		1	
53	CDM856E.12 II -020	右后侧玻璃	Right rear glass		1	
54	CDM856E.12 II -023	侧面吸音海绵	Side sound absorption		2	

驾驶室系统 Cab System

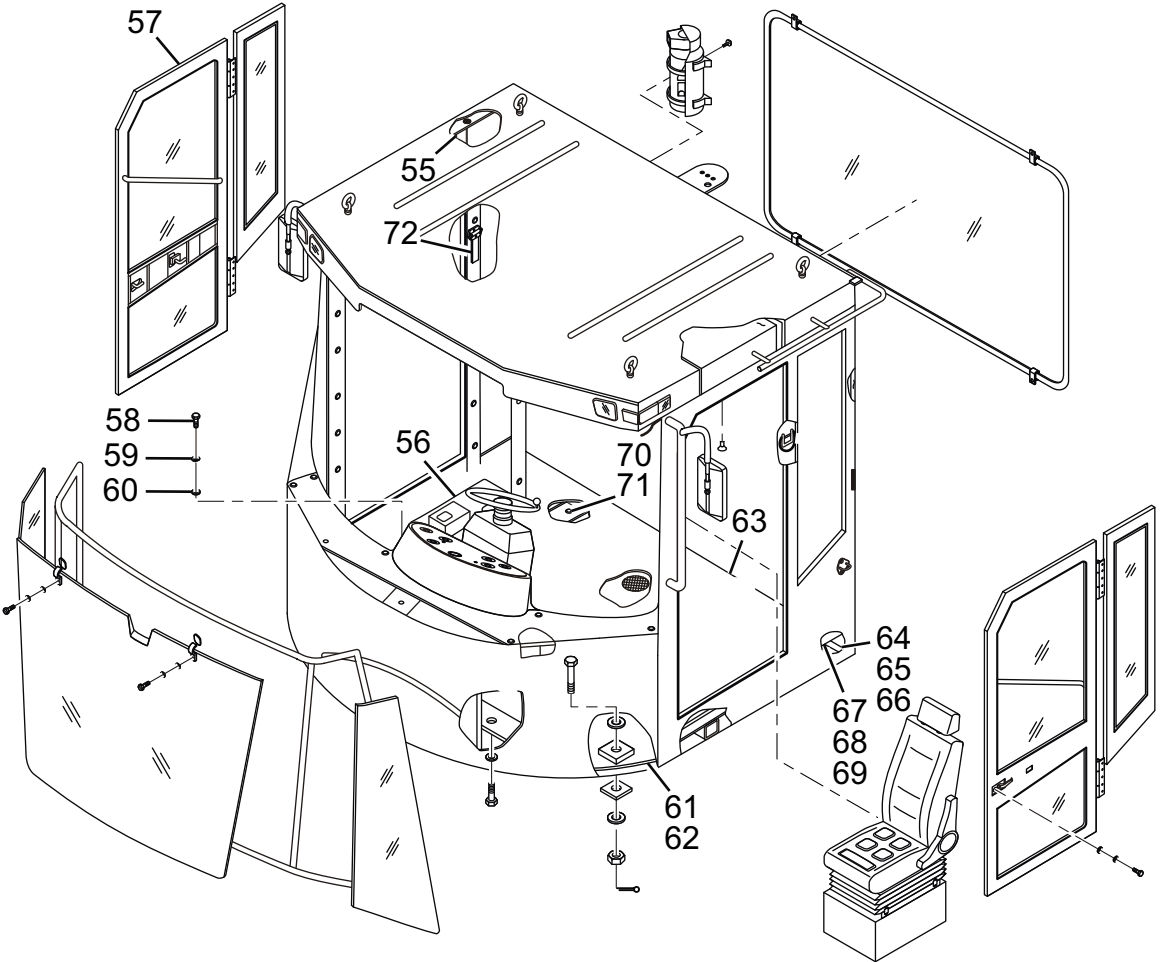

CAB SYSTEM

Figure 28

驾驶室系统 Cab System						
Item	Parts number	Chinese Description	English Description	Specification	Qty	Remarks
55	LG853.12.11	门框胶条	Doorframe rubber strip		2	
56	CDM855F.12.03	先导操纵箱	Pilot control box		1	
57	CDM856E.12 II .04	右门	Right door		1	
58	GB/T5783-2000	螺栓	Bolt	M16X75	10	8.8
59	GB/T93-1987	垫圈	Washer	16	20	
60	GB/T97.1-2002	垫圈	Washer	16	20	
61	CDM856E.12 II -021	地垫	Ground pad		1	
62	CDM856E.12 II -022	牛皮纸	Cowhide paper		1	
63	CDM860.12 I .02	底座	Seat		1	
64	CDM856E.12 I .12	空调出风后波纹管	Air-conditioned back wind bellows		1	
65	CDM856E.12 I .09	空调聚风罩	Wind hood		1	
66	GB/T845-2000	自攻螺钉	Taper screw	ST4.8X19	18	
67	CDM856E.12 I .11	空调出风波纹管	Air-conditioned back wind bellows		1	
68	CDM856E.12 I .10	风道安装板	Air channel mounting plate		1	
69	JB/T8870-1999	喉箍	Hoop	d80	5	
70	CDM856E.12 II -024	销	Pin		4	
71	GB/T93-1987	垫圈	Washer	30	2	
72	CDM858A.12 I .06	安全锤	Hammer		1	

Figure 28

驾驶室系统 Cab System

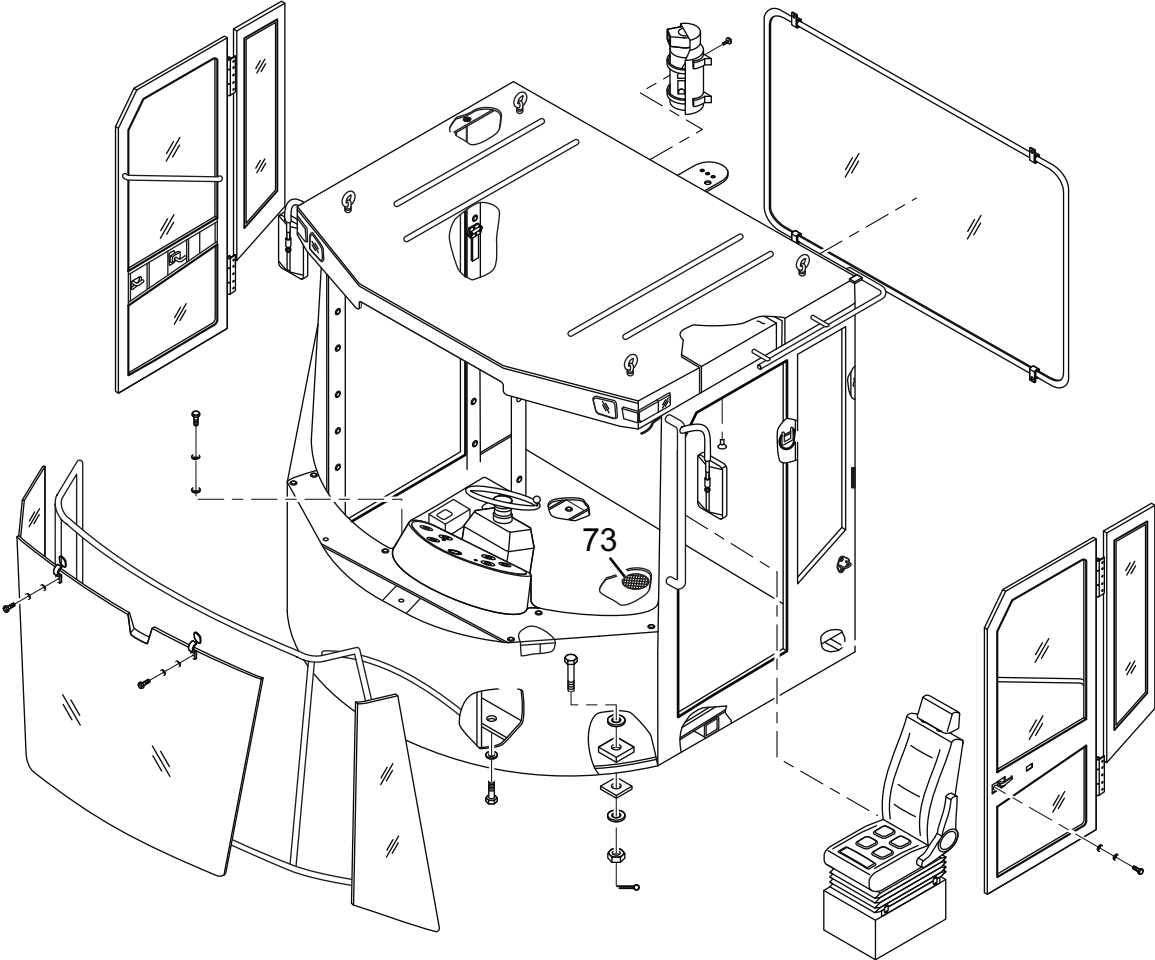

CAB SYSTEM

Figure 28

驾驶室系统 Cab System						
Item	Parts number	Chinese Description	English Description	Specification	Qty	Remarks
73	CDM856E.12 II .06	底板面吸音海绵	Lower panel sound absorption sponge		1	

覆盖件系统 Out panel system

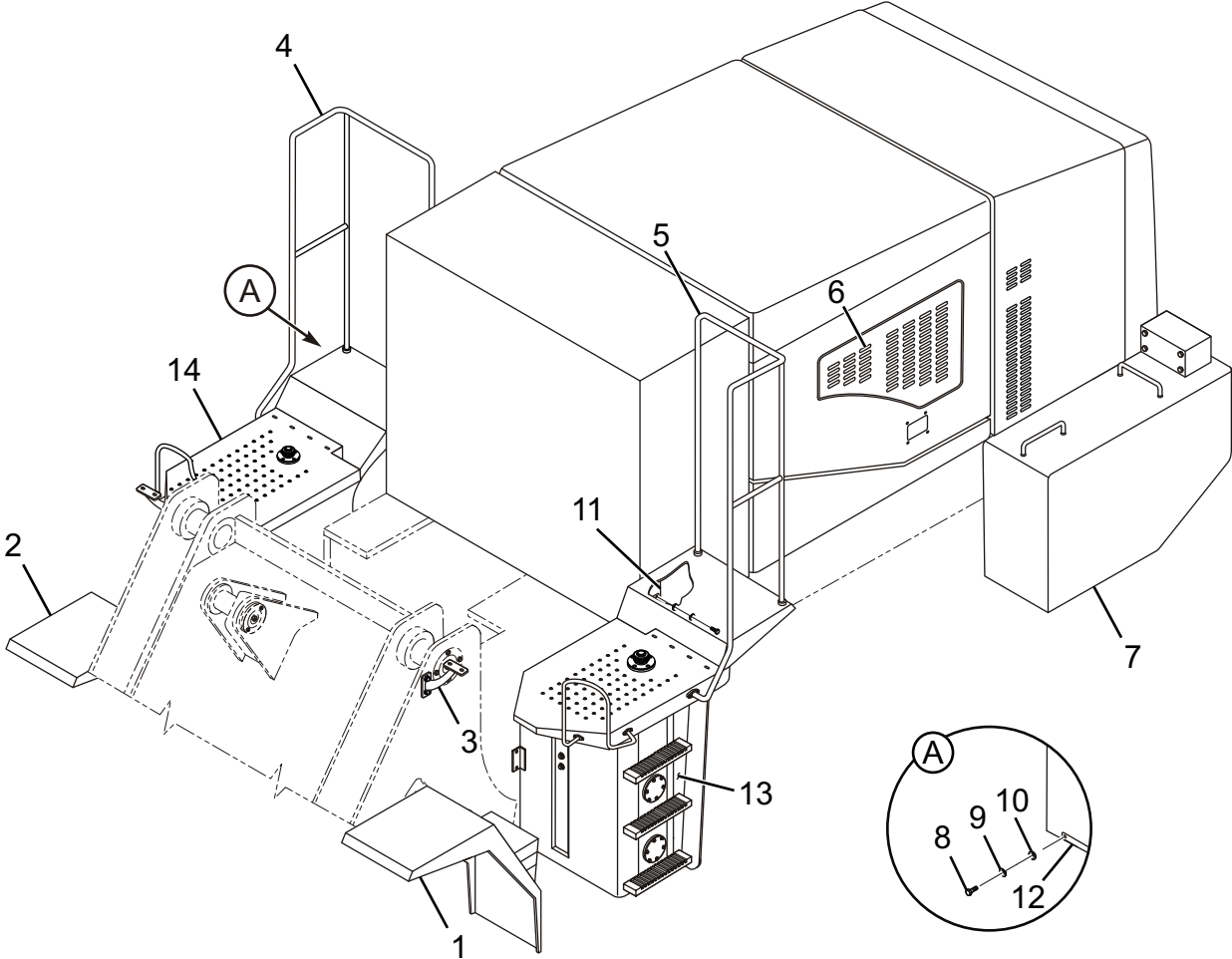

PANEL SYSTEM

Figure 29

覆盖件系统 Out Panel System						
Item	Parts number	Chinese Description	English Description	Specification	Qty	Remarks
1	CDM856E.13 I .01	前左挡泥板总成	Front left mud guard assembly		1	
2	CDM856E.13 I .02	前右挡泥板总成	Front right mud guard assembly		1	
3	LG853.13.03	组合灯支架	Combined lamp bracket		2	
4	LG50C.13 II .04	后右挡泥板总成	Rear right mud guard assembly		1	
5	LG50C.13 II .05	后左挡泥板总成	Rear left mud guard assembly		1	
6	CDM860.13 I .06	机罩总成	Engine hood assembly		1	
7	CDM860.13.07	平衡重	Counter weight assembly		1	
8	GB/T5783-2000	螺栓	Bolt	M8X20	10	8.8
9	GB/T93-1986	垫圈	Washer	8	10	
10	GB/T97.1-2002	垫圈	Washer	8	10	
11	CDM860.13 I .01	左封板	Left close board		1	
12	CDM860.13 I .02	右封板	Right close board		1	
13	CDM860.13.08	燃油箱总成	Fuel tank assembly		1	
14	CDM860.13.09	液压油箱总成	Hydraulic oil tank assembly		1	

Figure 30

液压油箱总成 Hydraulic Oil Tank Assembly (CDM860.13.09)

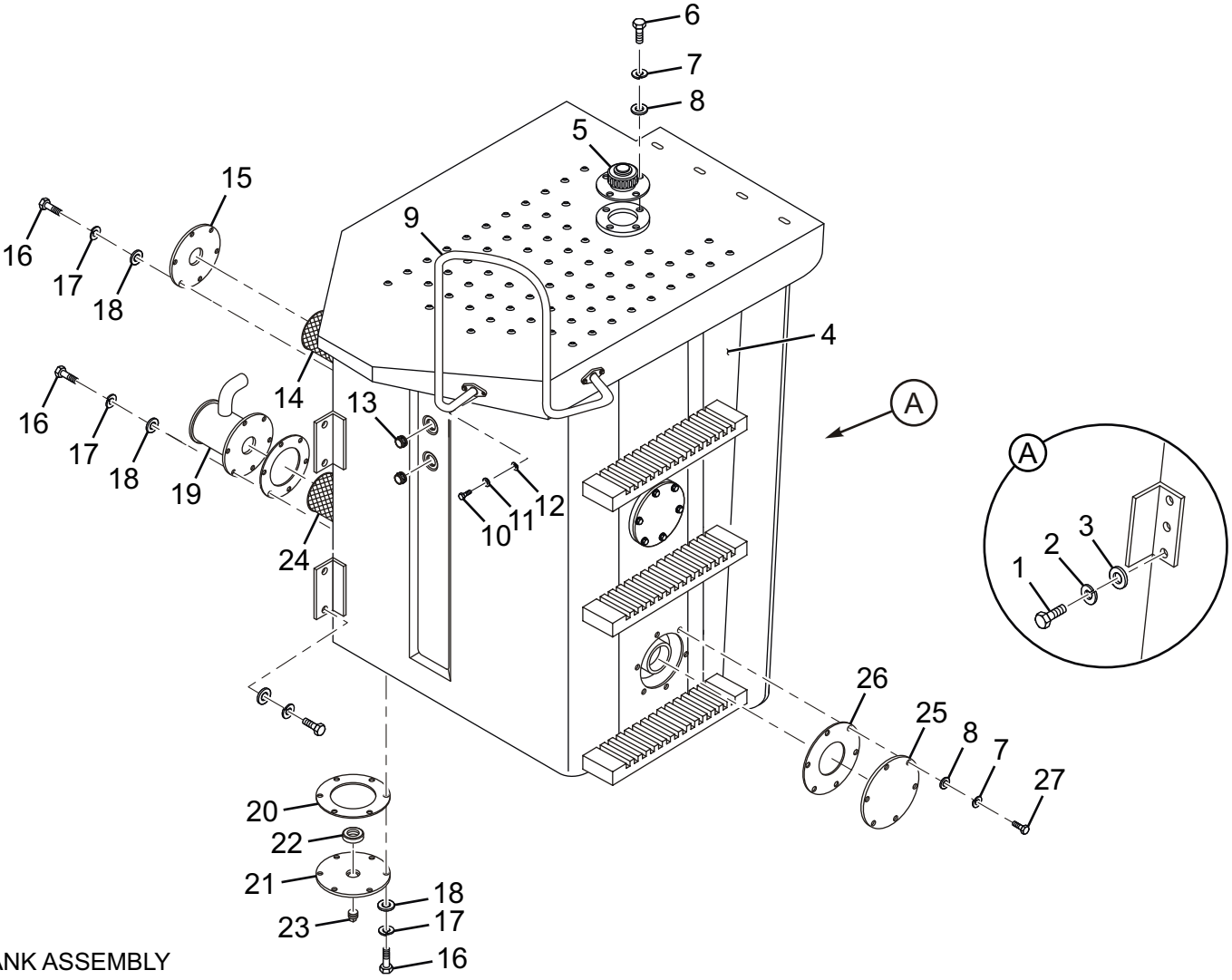

HYDRAULIC OIL TANK ASSEMBLY

Figure 30

液压油箱总成 Hydraulic Tank Assembly (CDM860.13.09)						
Item	Parts number	Chinese Description	English Description	Specification	Qty	Remarks
1	GB/T5783-2000	螺栓	Bolt	M16X40	3	8.8
2	GB/T93-1987	垫圈	Washer	16	3	
3	GB/T97.1-2002	垫圈	Washer	16	3	
4	CDM860.13.09.01	液压油箱体	Hydraulic oil tank body		1	
5	LG853.13.08.04	空气滤清器	Air filter		1	
6	GB/T5783-2000	螺栓	Bolt	M8X20	4	8.8
7	GB/T93-1987	垫圈	Washer	8	16	
8	GB/T97.1-2002	垫圈	Washer	8	16	
9	CDM860.13.09.02	左前扶手	Left front handrail		1	
10	GB/T5783-2000	螺栓	Bolt	M12X40	4	8.8
11	GB/T93-1987	垫圈	Washer	12	4	
12	GB/T97.1-2002	垫圈	Washer	12	4	
13	LG853.13.08.05	圆形油标	Round dip stick		2	
14	CDM856.13.09.01	回油滤芯	Oil return filter		1	
15	CDM860.13.09.04	法兰盖焊合	Flange cover weldment		1	
16	GB/T5783-2000	螺栓	Bolt	M10X25	18	8.8
17	GB/T93-1987	垫圈	Washer	10	18	
18	GB/T97.1-2002	垫圈	Washer	10	18	

液压油箱总成 Hydraulic Oil Tank Assembly (CDM860.13.09)

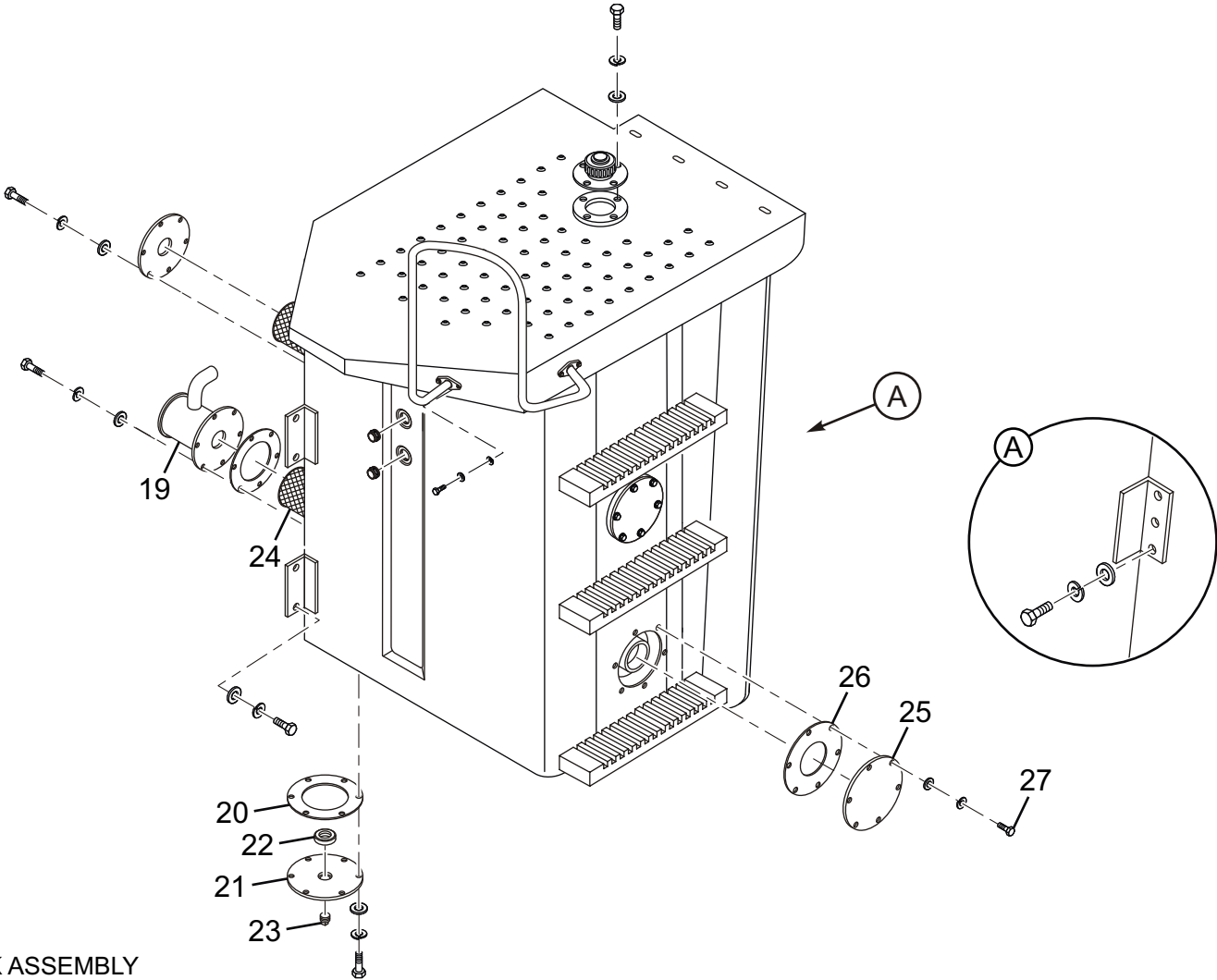

HYDRAULIC OIL TANK ASSEMBLY

液压油箱总成 Hydraulic Tank Assembly (CDM860.13.09)						
Item	Parts number	Chinese Description	English Description	Specification	Qty	Remarks
19	LG860.13.09.01	吸油管焊合	Oil suction pipe weldment		1	
20	LG853.13.08-002	垫片	Gasket		1	
21	LG853.13.08.03	放油盖	Oil drain cover		1	
22	LG853.13.08-003	磁铁	Magnet	φ80Xφ40X12	1	
23	LG853.13.08-001	堵头	plug		1	
24	CDM856.13.09.02	吸油滤芯	Oil suction filter core		1	
25	LG853.13.09.03	法兰盖	Flange cover		2	
26	LG853.13.09-002	垫片	Gasket		2	
27	GB/T5783-2000	螺栓	Bolt	M8X25	12	8.8

燃油箱总成 Fuel Tank Assembly (CDM860.13.08)

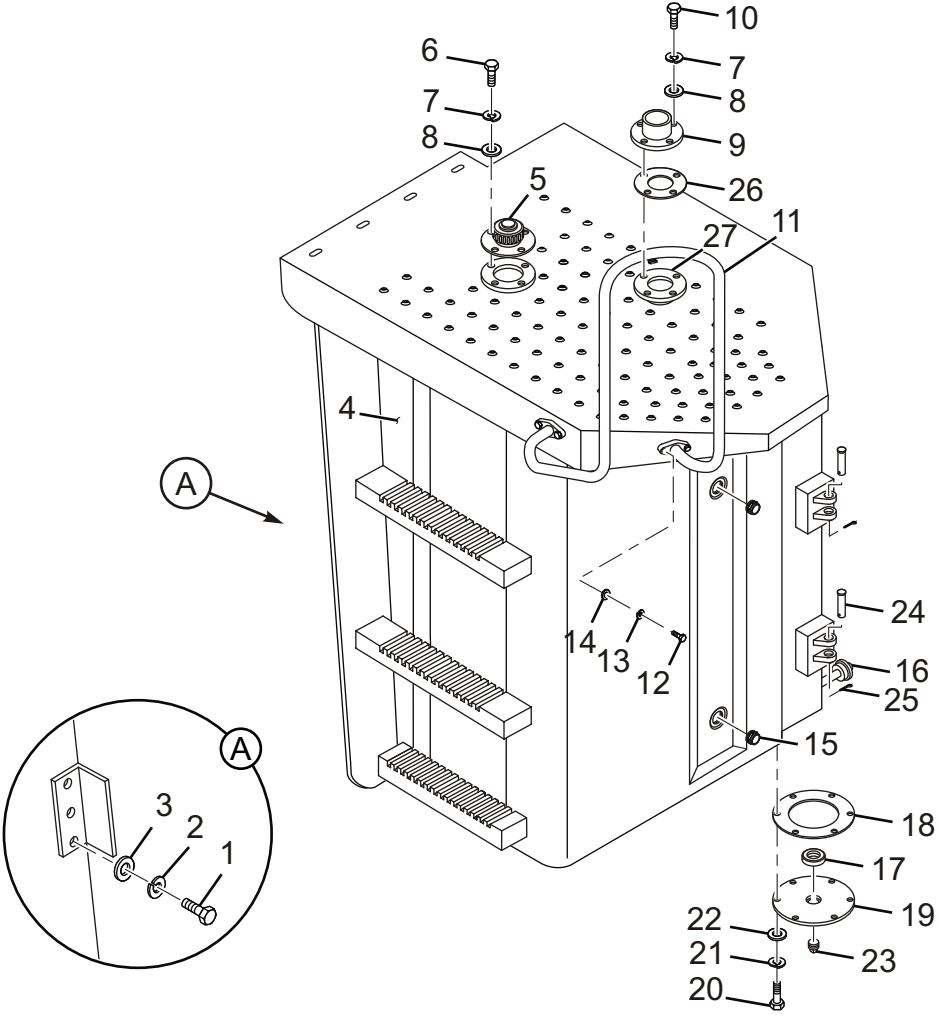

FUEL TANK ASSEMBLY

Figure 31

燃油箱总成 Fuel Tank Assembly (CDM860.13.08)						
Item	Parts number	Chinese Description	English Description	Specification	Qty	Remarks
1	GB/T5783-2000	螺栓	Bolt	M16X40	3	8.8
2	GB/T93-1987	垫圈	Washer	16	3	
3	GB/T97.1-2002	垫圈	Washer	16	3	
4	CDM860.13.08.01	燃油箱体	Fuel tank body		1	
5	LG853.13.08.04	空气滤清器	Air filter		1	
6	GB/T5783-2000	螺栓	Bolt	M8X20	4	8.8
7	GB/T93-1987	垫圈	Washer	8	7	
8	GB/T97.1-2002	垫圈	Washer	8	7	
9	CDM856E.13 I.08-001	液位计盖板	Liquid indicator cover board		1	
10	GB/T5783-2000	螺栓	Bolt	M8X16	3	8.8
11	CDM860.13.08.02	右前扶手	Right front handrail		1	
12	GB/T5783-2000	螺栓	Bolt	M12X40	4	8.8
13	GB/T93-1987	垫圈	Washer	12	4	
14	GB/T97.1-2002	垫圈	Washer	12	4	
15	LG853.13.08.05	圆形油标	Round dip stick		3	
16	LG853.13.08.02	吸油滤油器总成	Oil suction oil filter assembly		1	
17	LG853.13.08-003	磁铁	Magnet	φ80Xφ40X12	1	
18	LG853.13.08-002	垫片	Gasket		1	

燃油箱总成 Fuel Tank Assembly (CDM860.13.08)

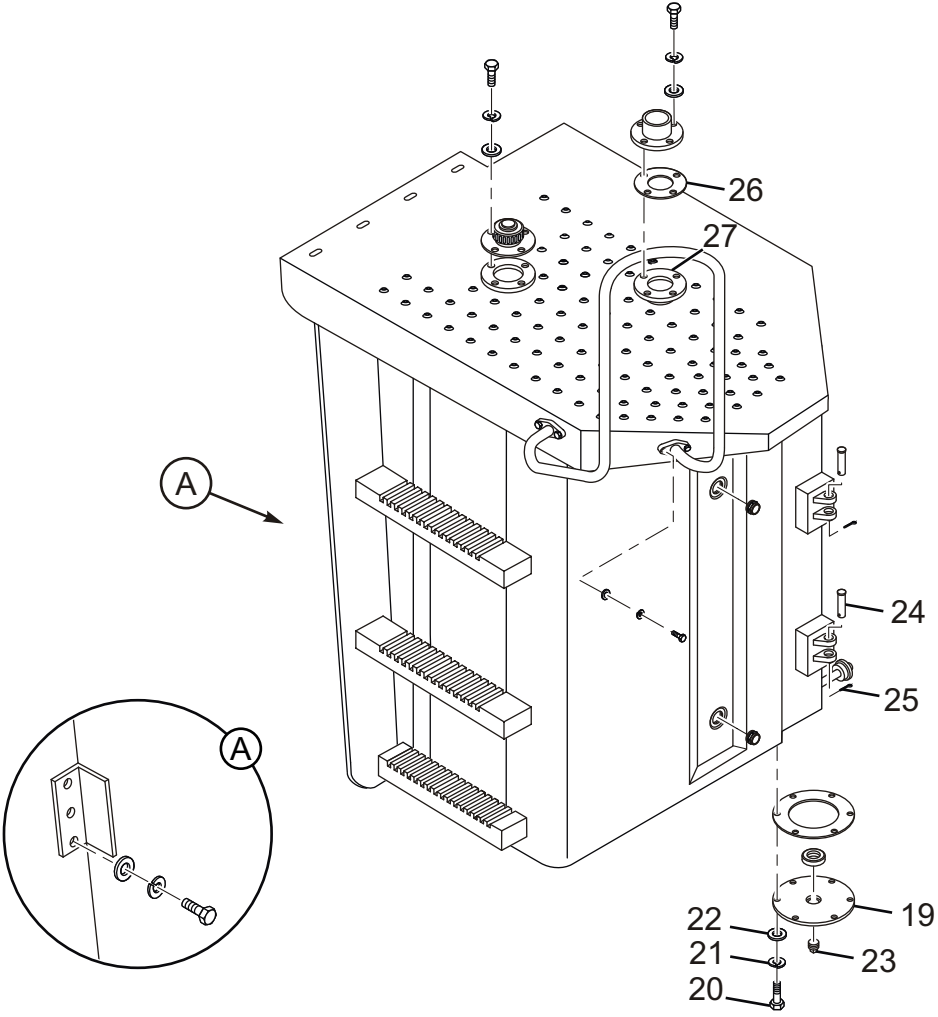

FUEL TANK ASSEMBLY

Figure 31

燃油箱总成 Fuel Tank Assembly (CDM860.13.08)						
Item	Parts number	Chinese Description	English Description	Specification	Qty	Remarks
19	LG853.13.08.03	放油盖	Oil drain cover		1	
20	GB/T5783-2000	螺栓	Bolt	M10X25	6	8.8
21	GB/T93-1987	垫圈	Washer	10	6	
22	GB/T97.1-2002	垫圈	Washer	10	6	
23	LG853.13.08-001	堵头	Plug		1	
24	LG855.13.08-001	销轴	Pin shaft		2	
25	GB/T91-2000	开口销	Cotter pin	4X50	2	
26	CDM860.13.08-001	垫片	Tie plate		1	
27	CDM860.13.08-002	盖板	Cover board		1	

Figure 32

电器系统 Electrical System

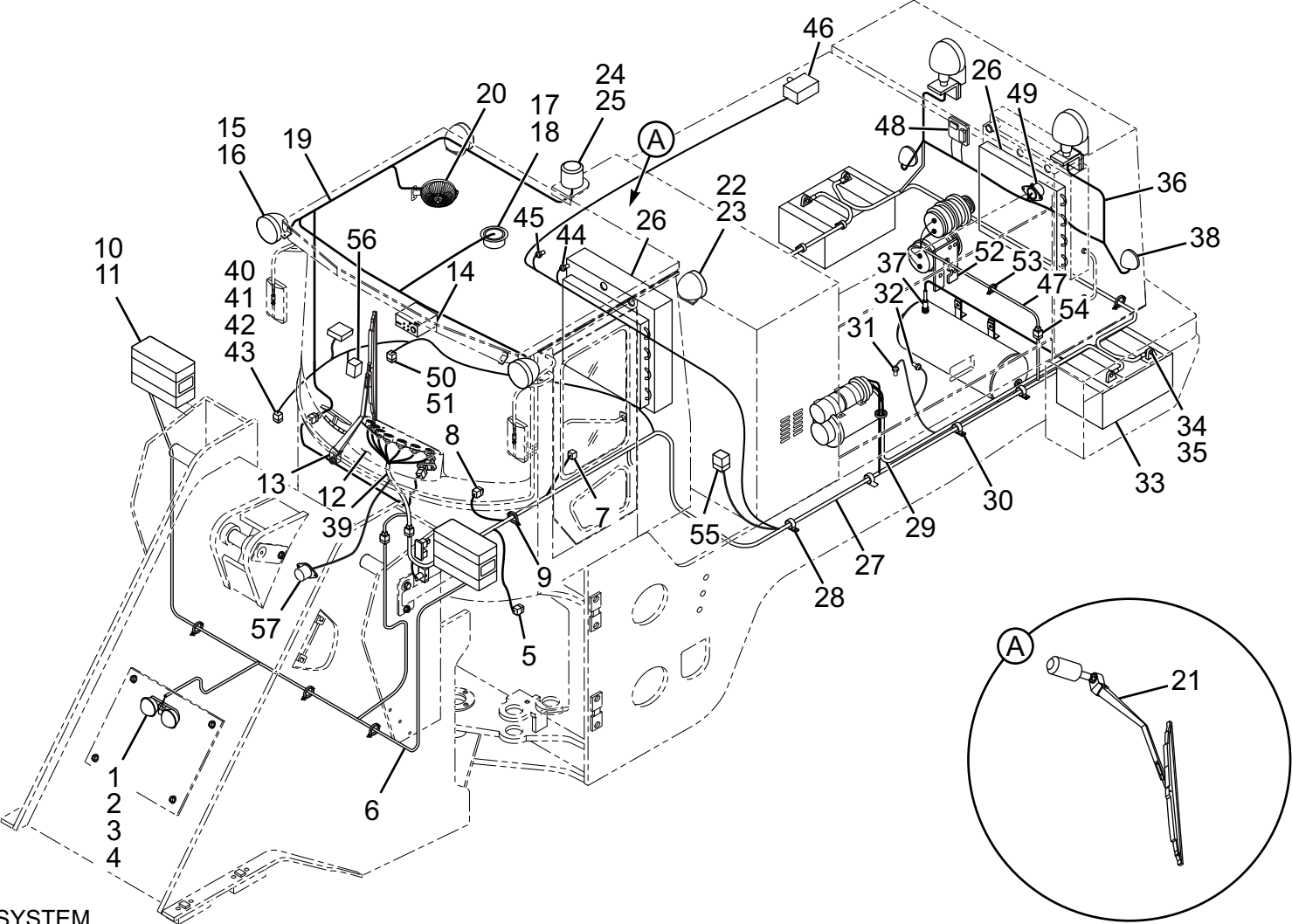

ELECTRICAL SYSTEM

Figure 32

电器系统 Electrical System						
Item	Parts number	Chinese Description	English Description	Specification	Qty	Remarks
1	LG853.15.09	电喇叭总成	Electrical horn assembly	DL50D-24	1	
2	GB/T5783-2000	螺栓	Bolt	M8X16	4	8.8
3	GB/T93-1987	垫圈	Washer	8	28	
4	GB/T97.1-2002	垫圈	Washer	8	32	
5	LG855.15.44	压力式发讯器	Pressure type message sender	CY-II	1	
6	CDM858.15 I .01	前车架线束	Front frame harness		1	
7	CDM856E.15 I .33	制动气压传感器	Brake air press sensor	R1/8	1	仪表台总成带
8	LG853.15.30	制动灯开关	Brake lamp switch	JN150	1	
9	LG853.15-001	尼龙扎带	Nylon strip	ZD250X5	40	
10	LG853.15.10	前组合灯	Front combined lamp	HDF-02D	2	左右各一
11	GB/T5783-2000	螺栓	Bolt	M8X25	8	
12	CDM860.15 I .60	仪表台总成	Instrument panel assembly		1	泰兴华骋
13	CDM856E.15 I .22	雨刮器总成	Wiper assembly	2D2531P	1	乐清汽车刮水器厂
14	LG856.15.18	MP3 播放机	MP3 player		1	
15	LG856.15.23	前工作灯（左、右）	Front working lamp (left, right)		2	左右各一
16	LG856.15.24	前转向灯（左、右）	Front steering lamp(left, right)		2	左右各一
17	LG856.15.25	吸顶灯	Rectangle ceiling lamp	D171	1	
18	GB/T845-2000	自攻螺钉	Taper screw	ST4.8X19	3	

Figure 32

电器系统 Electrical System

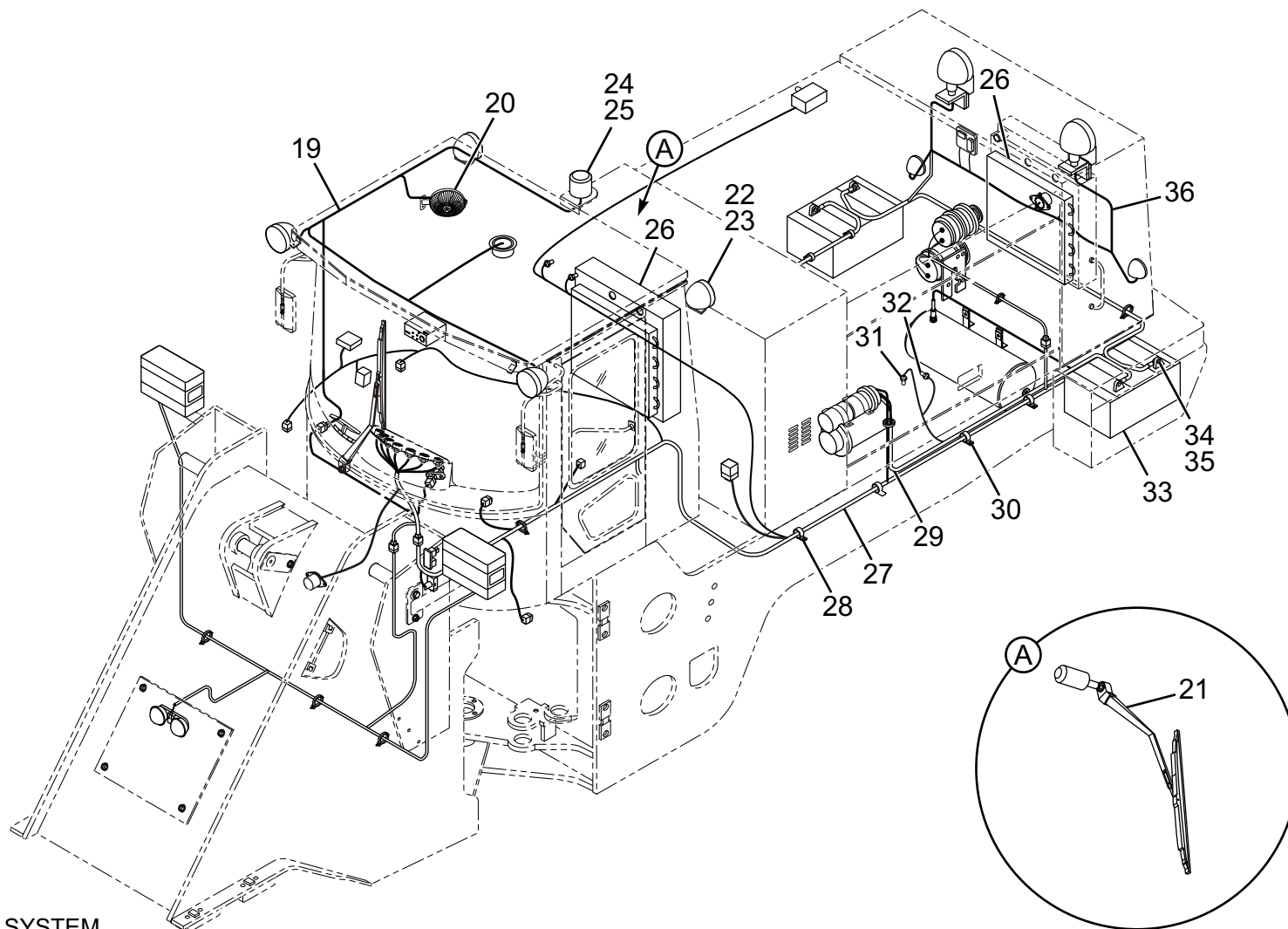

ELECTRICAL SYSTEM

Figure 32

电器系统 Electrical System						
Item	Parts number	Chinese Description	English Description	Specification	Qty	Remarks
19	CDM860.15 I .02	驾驶室线束	Cab harness		1	
20	LG855.15.45	电风扇	Fan	SGF-03A	1	
21	CDM856E.15 I .23	雨刮器总成	Wiper assembly	600×500 (95 °)	1	
22	GB/T923-88	盖形螺母	Cap nut	M12	2	
23	CDM835E.15.12	前照灯	Front lamp	WD105X105	4	
24	GB/T923-88	盖形螺母	Cap nut	M10	3	
25	CDM858A.15 II .48	警示灯	Warning lamp	SB4000	1	泰兴华骋
26	CDM855F.15.19	电装空调总成	Air-condition assembly		1	压缩机槽型为 A 型
27	CDM860.15 I .03	后车架线束	Rear frame harness		1	
28	CDM855.15 V .51	连教条喉箍	Hoop	Φ 30 (钢带宽 20mm)	3	
29	CDM860.15 I .05	电瓶线	Battery wire		1	
30	CDM855.15 V .53	连教条喉箍	Hoop	Φ 40 (钢带宽 20mm)	3	
31	LG856.15.29	机油压力传感器	Engine oil pressure sensor	Rc1/8	1	仪表台总成带
32	LG856.15.26	发动机水温传感器	Engine water temperature sensor	NPT3/8	1	仪表台总成带
33	LG853.15.26	蓄电池	Battery	N120(12V120Ah)	2	
34	GB/T5783-2000	螺栓	Bolt	M8X30	4	8.8
35	GB/T6170-2000	螺母	Nut	M8	4	8
36	CDM860.15.04	后罩灯线束	Rear hood light harness		1	

Figure 32

电器系统 Electrical System

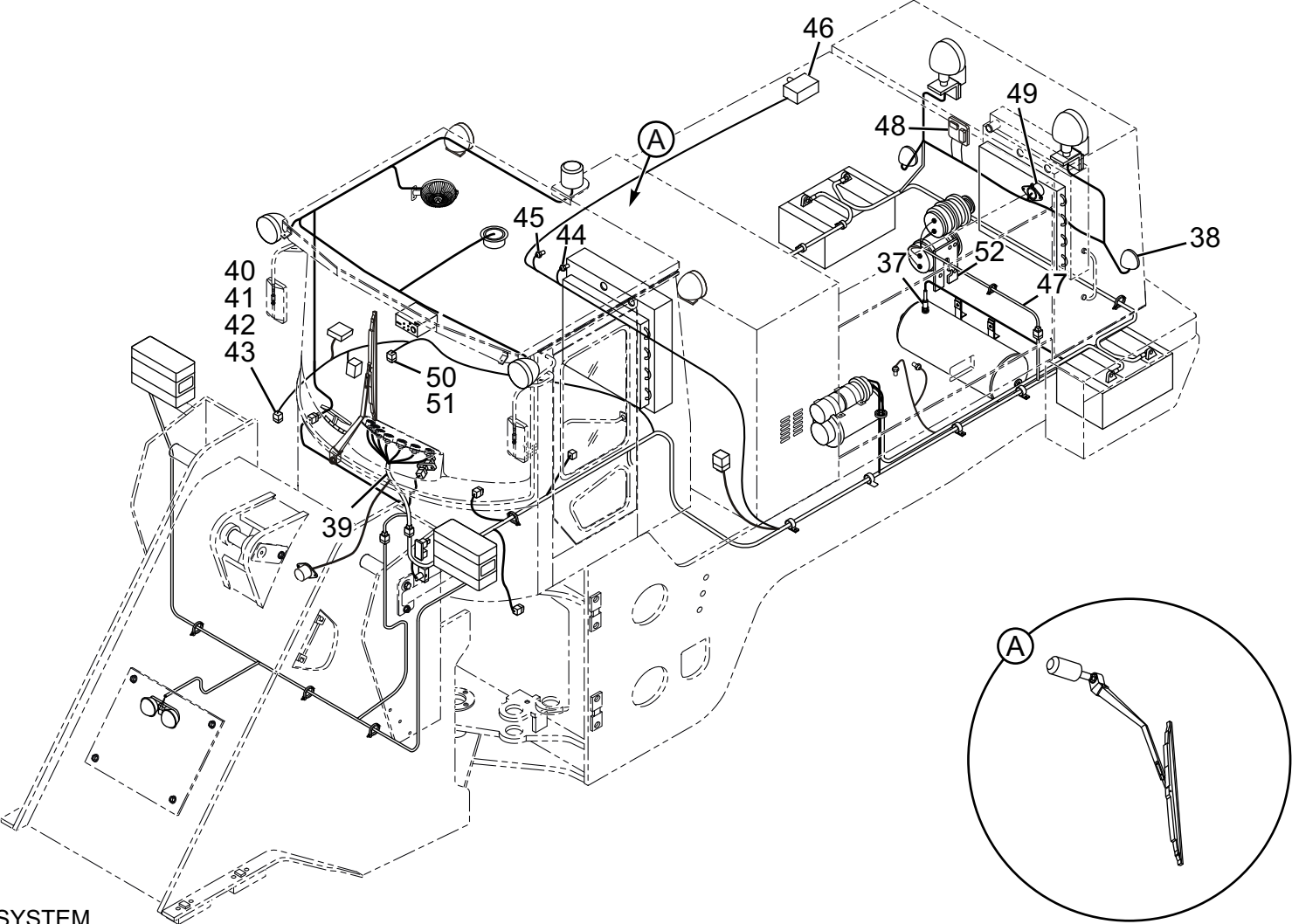

ELECTRICAL SYSTEM

Figure 32

电器系统 Electrical System						
Item	Parts number	Chinese Description	English Description	Specification	Qty	Remarks
37	CDM855F.15-001	螺堵	stud	M12X1.5	1	锐帆德 L4H-12
38	LG50C.15 I .28	后尾灯	Taillights	SY-022	2	左右各 1
39	CDM860.15 I .06	仪表台线束	Instrument platform harness		1	仪表台总成带
40	GB/T67-2000	螺钉	Screw	M5X16	4	
41	GB/T97.1-2002	垫圈	Washer	5	4	
42	GB/T93-1987	垫圈	Washer	5	4	
43	LG856.15.32	燃油油位传感器	Fuel level sensor		1	仪表台总成带
44	LG856.15.30	变速油温传感器	Transmission oil temperature sensor	NPT3/8	1	仪表台总成带
45	CDM858.15.31	变速油压报警开关	Transmission oil pressure alarm switch	M10X1	1	仪表台总成带
46	LG855.15.43	压差发讯器	Pressure difference message sender		1	
47	LG856.15 I .08	发电机线束	Engine harness		1	
48	CDM858A.15 II .50	电源总开关	Main power switch		1	上海金蔚
49	CDM855E.15 II .20	倒车蜂鸣器	Back up buzzer	JWL-FM212/24V	1	上海金蔚
50	CDM855E.15 II .50	冷启动系统	Cold start system	YRZZ2455-6	1	选配
51	CDM855E.15 II -001	冷启动安装板	Cold start fixing plate		2	选配
52	LG863.15.46	空调压缩机支架	Air conditioning compressor support		4	

Figure 32

电器系统 Electrical System

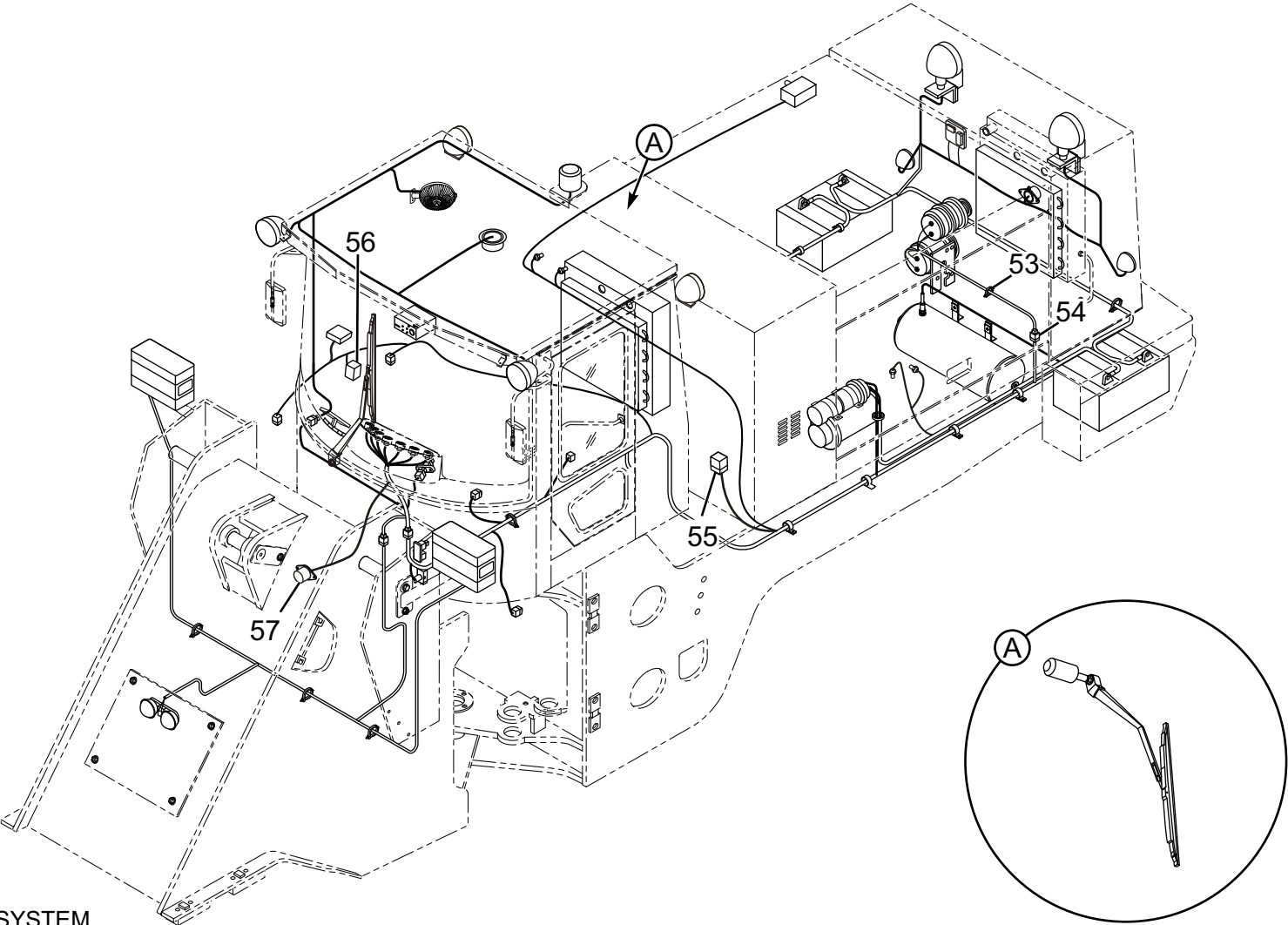

ELECTRICAL SYSTEM

Figure 32

电器系统 Electrical System						
Item	Parts number	Chinese Description	English Description	Specification	Qty	Remarks
53	LG853.15.15.05	喉箍	Hoop	Φ16-25	2	RFD-NF1-05010
54	LG853.15.15.04	暖风机水阀	Heater water valve		4	RFD-NF1-05030
55	CDM856E.15 I .09	空调线束	Air conditioning harness		1	
56	CDM835E.15 I .35	继电器	Replay	HD4195C/024-1H/9M1	1	上海沪工
57	LG853.15.31	低压报警蜂鸣器	Low pressure alarm buzzer	FM251	1	

Figure 33

随机工具 Tool kit

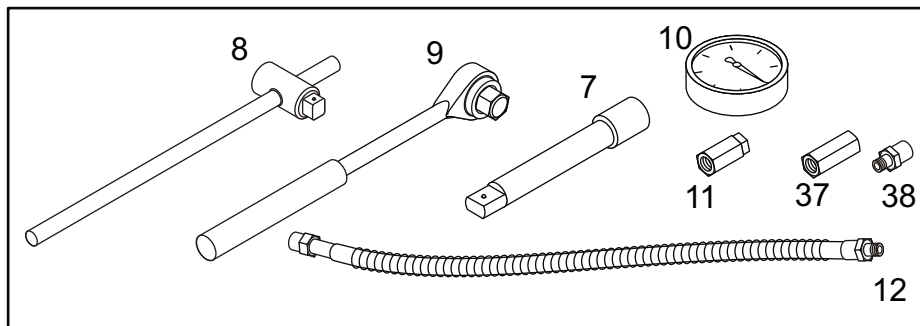
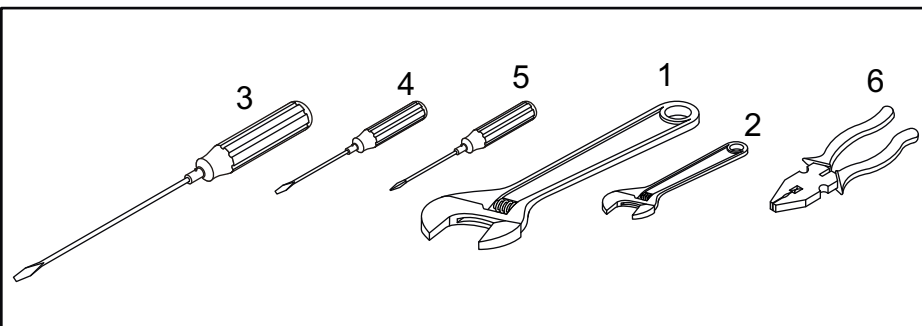
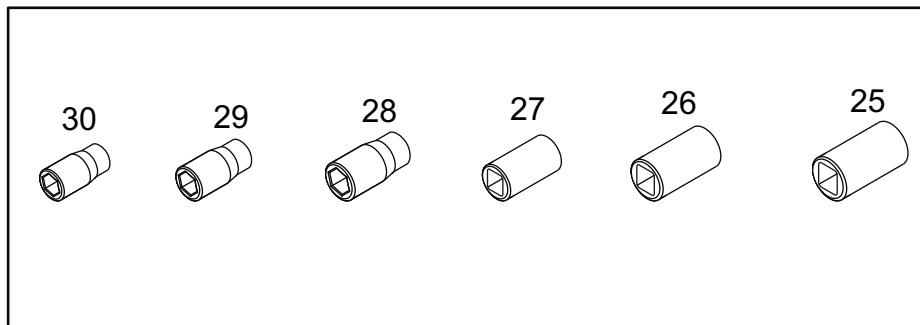
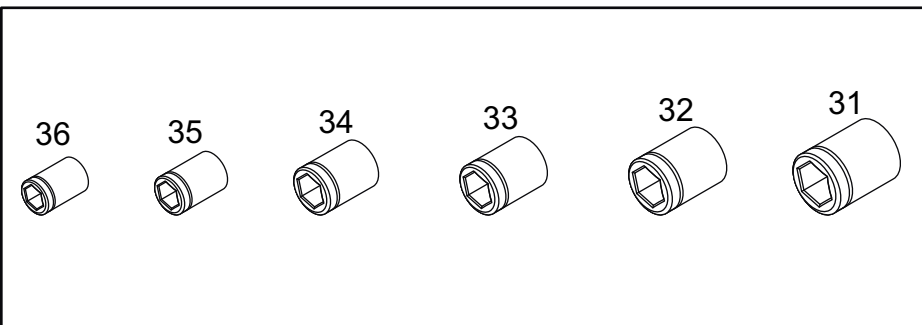
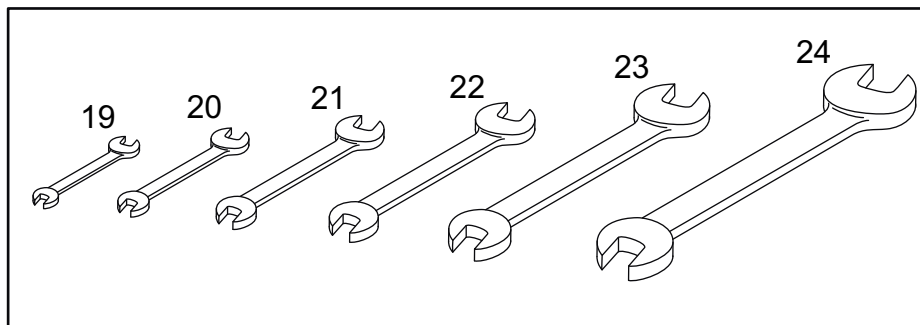
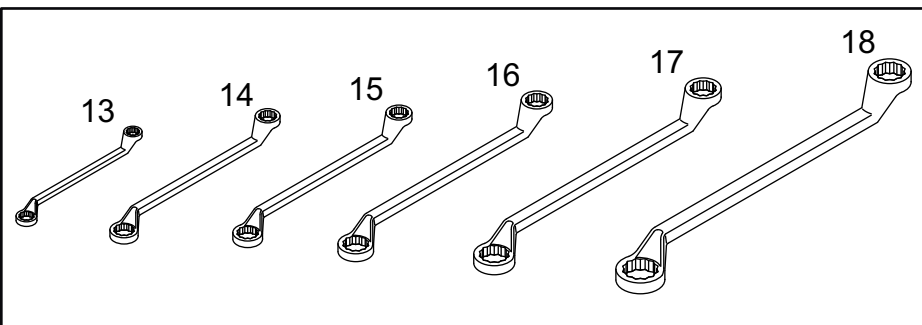

TOOL KIT

Figure 33

随机工具 Tool kit					
Item	Chinese Description	English Description	Specification	Qty	Remarks
1	活动扳手	Shifting spanner	375mm	1	
2	活动扳手	Shifting spanner	200mm	1	
3	一字螺丝刀	Flat screw driver	250mm	1	
4	一字螺丝刀	Flat screw driver	125mm	1	
5	十字螺丝刀	Cross screw driver	125mm	1	
6	钢丝钳	Pliers		1	
7	短接杆	Short connecting rod		1	
8	棘轮柄	Ratchet handle		1	
9	滑行柄	Sliding handle		1	
10	压力表	Pressure gauge		1	
11	压力表接头	Pressure gauge connector		1	
12	制动软管	Brake hose	NJ130	1	
13	梅花扳手	Offset ring spanner	10-12	1	
14	梅花扳手	Offset ring spanner	13-15	1	
15	梅花扳手	Offset ring spanner	14-17	1	
16	梅花扳手	Offset ring spanner	17-19	1	
17	梅花扳手	Offset ring spanner	22-24	1	
18	梅花扳手	Offset ring spanner	27-30	1	

Figure 33

随机工具 Tool kit

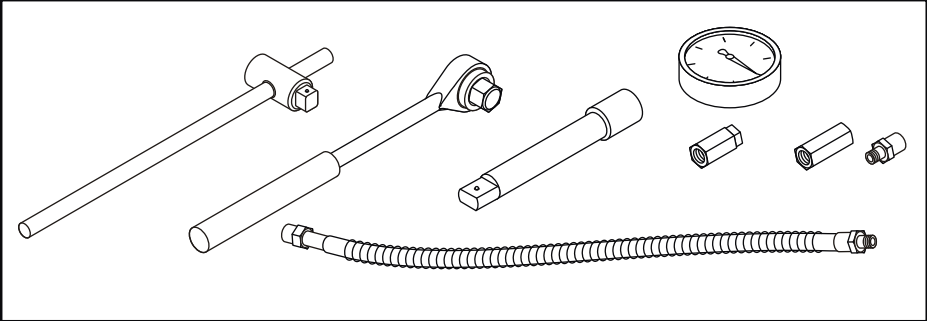
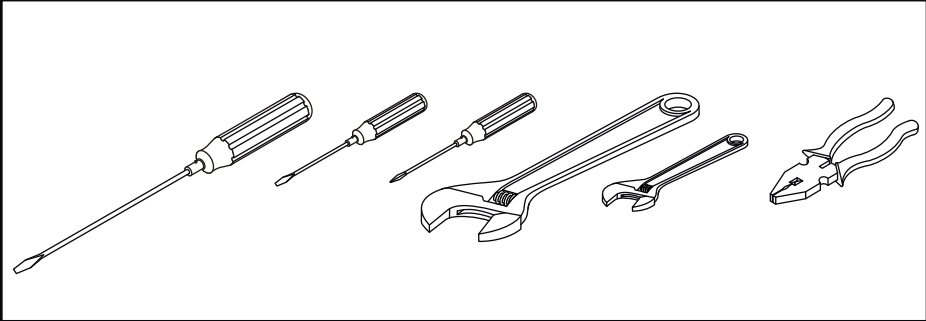
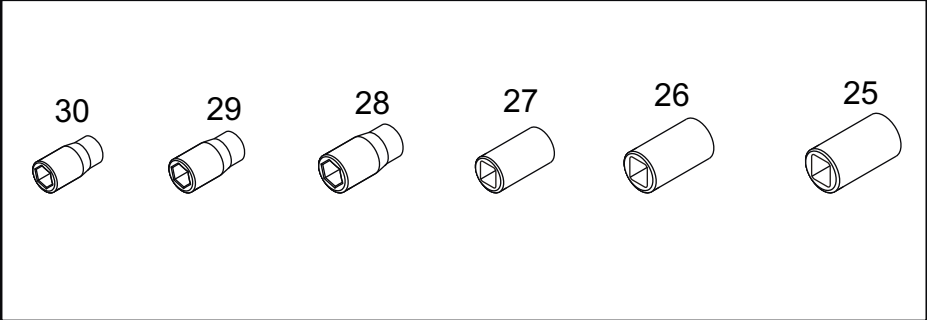
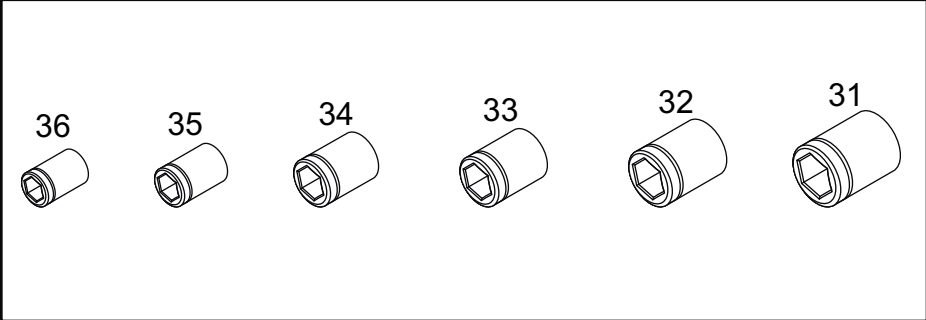
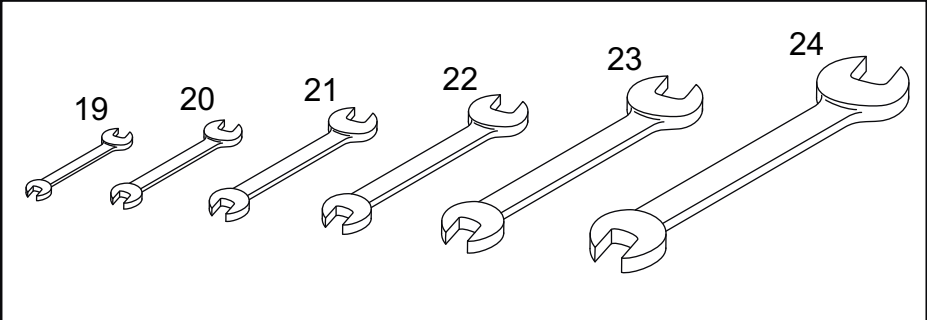
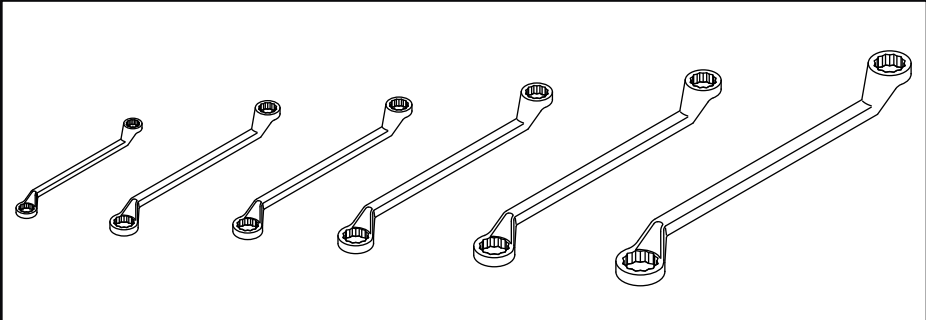

TOOL KIT

Figure 33

随机工具 Tool kit					
Item	Chinese Description	English Description	Specification	Qty	Remarks
19	呆扳手	Non-shifting spanner	10-12	1	
20	呆扳手	Non-shifting spanner	13-15	1	
21	呆扳手	Non-shifting spanner	14-17	1	
22	呆扳手	Non-shifting spanner	16-18	1	
23	呆扳手	Non-shifting spanner	22-24	1	
24	呆扳手	Non-shifting spanner	17-30	1	
25	套筒	Socket	Φ 32	1	
26	套筒	Socket	Φ 27	1	
27	套筒	Socket	Φ 24	1	
28	套筒	Socket	Φ 22	1	
29	套筒	Socket	Φ 19	1	
30	套筒	Socket	Φ 18	1	
31	套筒	Socket	Φ 17	1	
32	套筒	Socket	Φ 16	1	
33	套筒	Socket	Φ 14	1	
34	套筒	Socket	Φ 13	1	
35	套筒	Socket	Φ 12	1	
36	套筒	Socket	Φ 11	1	

Figure 33

随机工具 Tool kit

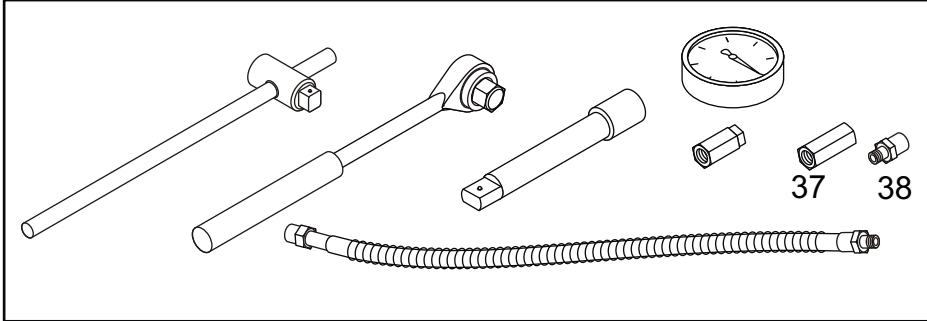
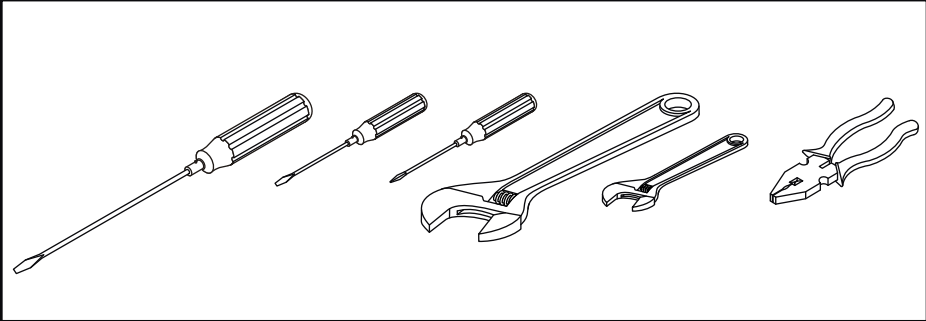
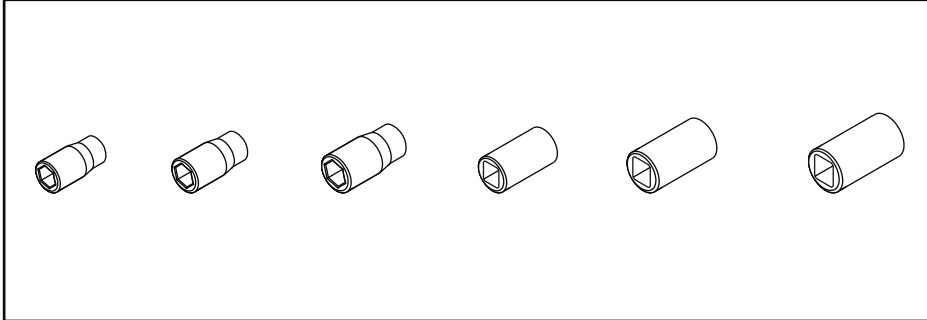
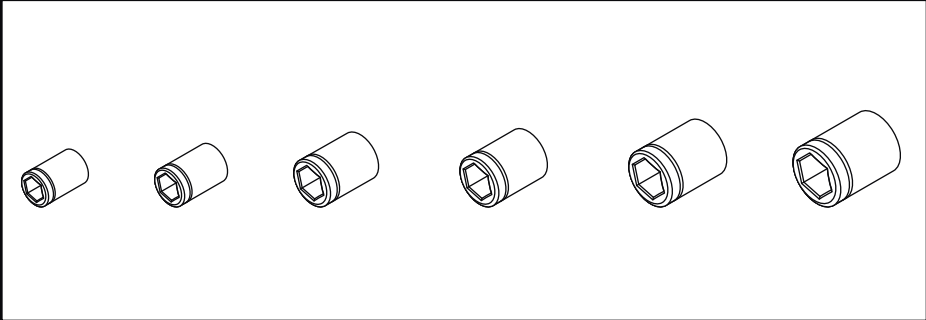
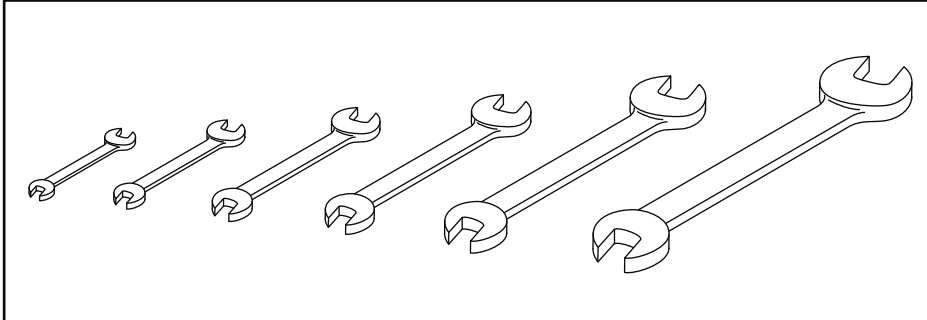
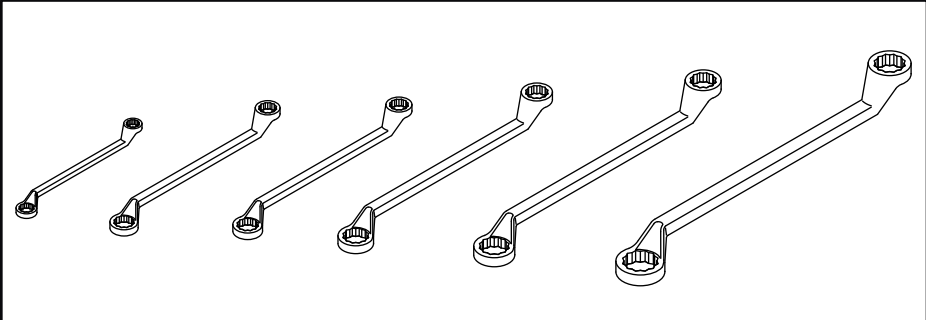

TOOL KIT

Figure 33

随机工具 Tool kit					
Item	Chinese Description	English Description	Specification	Qty	Remarks
37	直接头	Straight connector		1	
38	测压接头	Pressure connector		1	

标志标牌系统 (Warning mark system)

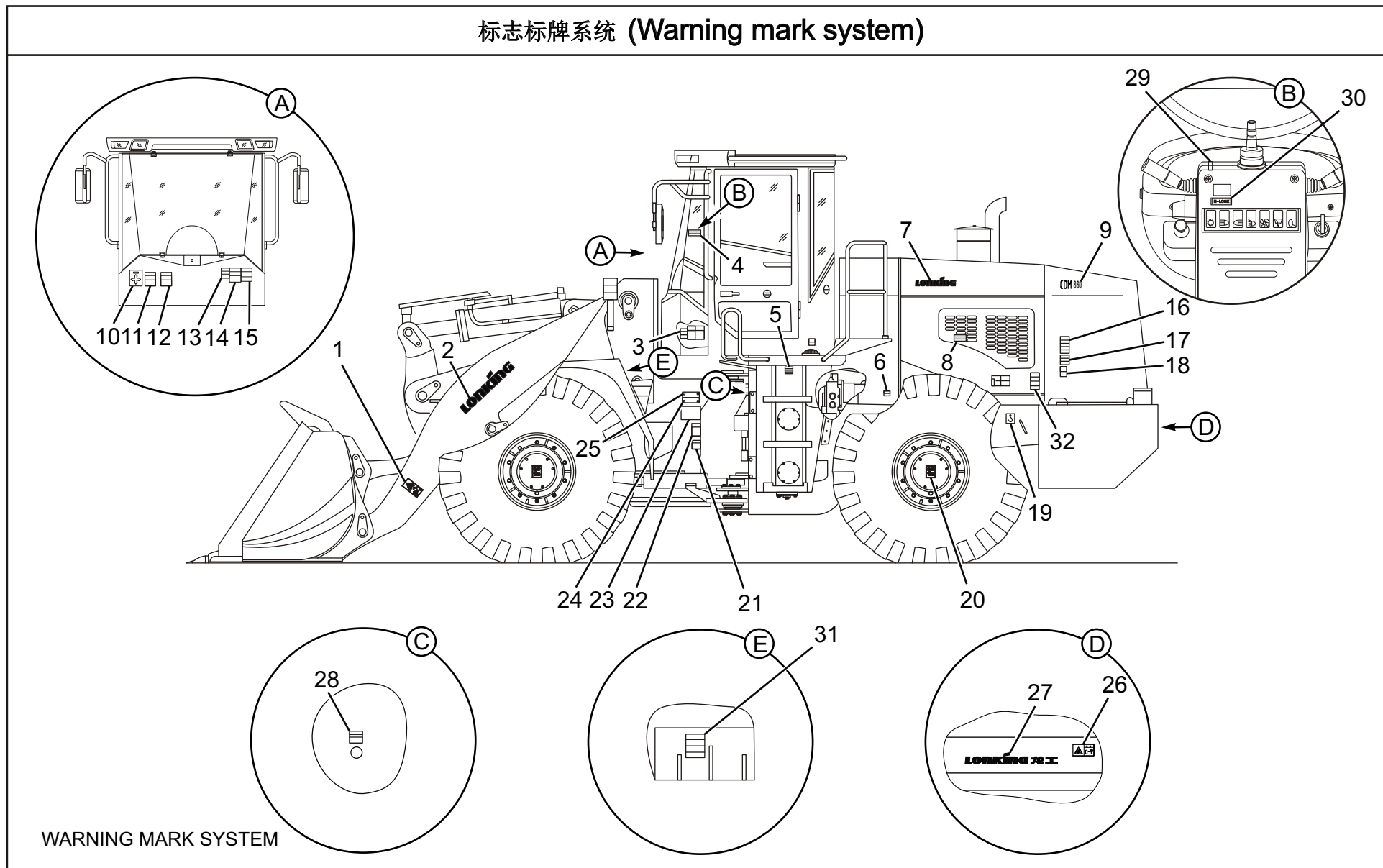

WARNING MARK SYSTEM

警告标识 Warning Mark System						
Item	Parts number	Chinese Description	English Description	Specification	Qty	Remarks
1	LG853.14-001	动臂安全标志	Lift arm warning label		2	
2	CDM858.14 I -003	动臂用 LONKING	"LONKING" on lift arm		2	
3	CDM856E.14 I -012	机体焊接警告标志	Machine welding warning label		1	
4	LG853.14-022	机器保养及定检要求	Maintenance and regular inspection requirement		1	
5	LG853.14-012	液压油标识	Hydraulic oil label		2	
6	LG856.14-008	洗涤剂水壶标识	Flusher container label		1	
7	CDM858.14 I -004	机罩用 LONKING	"LONKING" on engine hood		2	
8	CDM856E.14 I -004	高温处防烫伤警告标识	Prevent burning warning label		2	
9	CDM860.14-002	后罩标志	Rear hood label		2	
10	CDM856E.14 I -007	先导操纵标识	Implement control label		1	
11	CDM856E.14 I -005	油品使用说明	Instructions of oil use		1	
12	CDM856E.14 I -006	整机配件维修注意事项	Precautions of parts maintenance		1	
13	CDM856E.14 I -011	停车警告标志	Safe parking warning label		1	
14	CDM856E.14 I -013	起动前准备工作	Points to note before starting		1	
15	LG853.14-015	警告用户	Warning		1	
16	LG853.14-007	风扇警告标志	Fan warning label		2	
17	CDM856E.14 I -014	电瓶接线标志	Battery connecting wire label		2	

标志标牌系统 (Warning mark system)

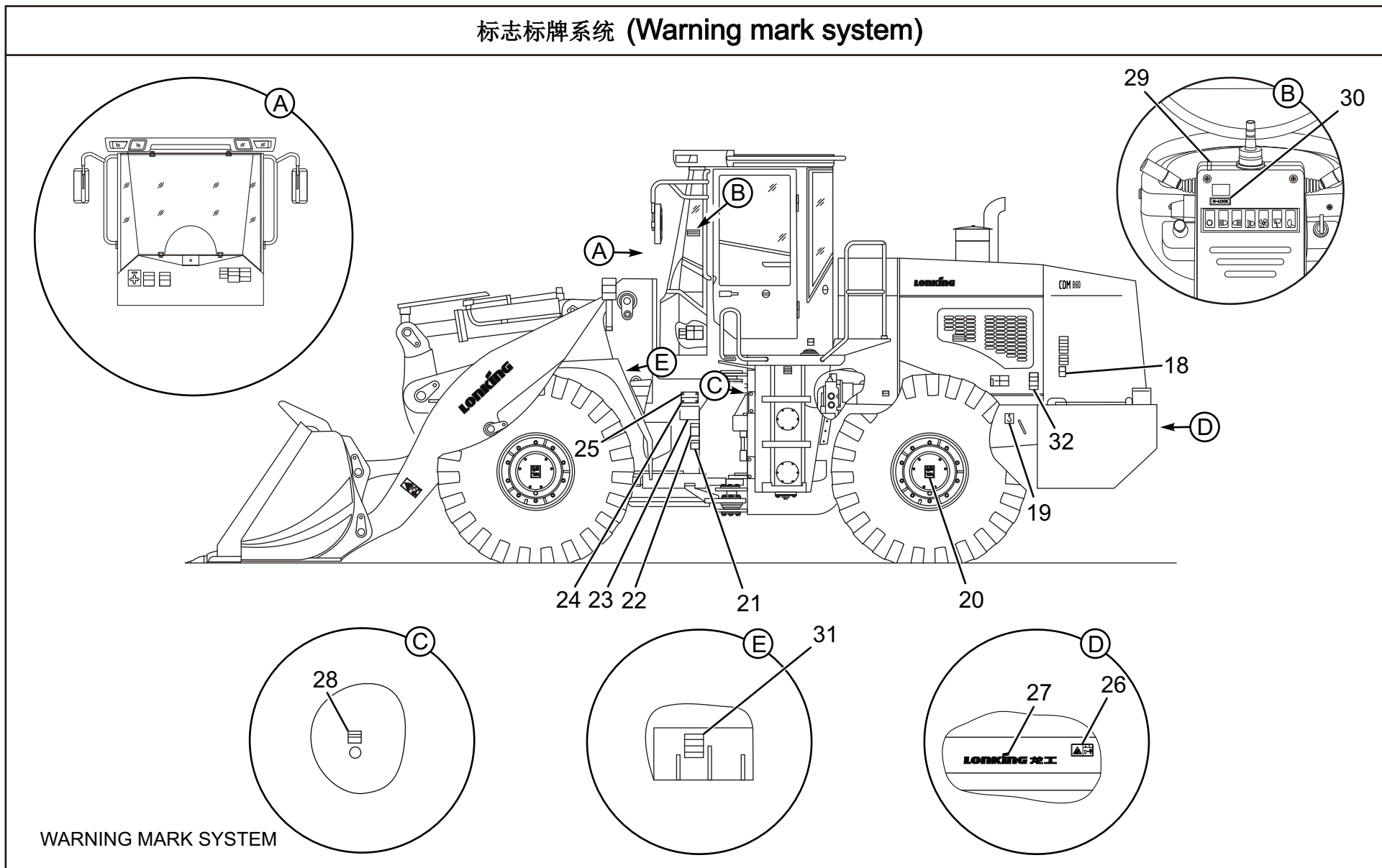

WARNING MARK SYSTEM

Figure 34

警告标识 Warning Mark System						
Item	Parts number	Chinese Description	English Description	Specification	Qty	Remarks
18	CDM856E.14 I -015	防冻液警告标识	Anti-freezing fluid warning label		2	
19	LG853.14-011	起吊标志	Lifting label		4	
20	CDM855E.14 I -010	轮边减速警告标志	Wheel side reduction label		4	
21	CDM856E.14 I -009	维修及运输警告标识	Maintain and transportation warning label		2	
22	CDM856E.14 I -010	铰接安全标志	Articulation safety label		2	
23	CDM856E.14 I -003	黄油嘴分布图	Grease fitting distribution map		1	
24	CDM860.14 I -001	铭牌	Nameplate		1	
25	GB/T12618	开口型扁圆头抽芯铆钉	Mushroom head break mandrel blind rivets		4	
26	CDM855E.14 I -005	倒车警告标志	Safe parking warning label		1	
27	CDM858.14 I -005	配重后 LONKING	"LONGKING" on counterweight		2	
28	LG853.14-017	燃油标识	Fuel label		2	
29	CDM858.14 I -006	档位标识	Gear label		1	
30	CDM858.14 I -007	档位锁标识	Gear lock label		1	
31	CDM856E.14 I -008	禁止踩踏警告标志	Don't step on it-warning label		2	
32	CDM858.14 I -008	发动机皮带轮警告标识	Engine strap wheel warning label		2	

GREASING POINTS INDICATION LAYOUT

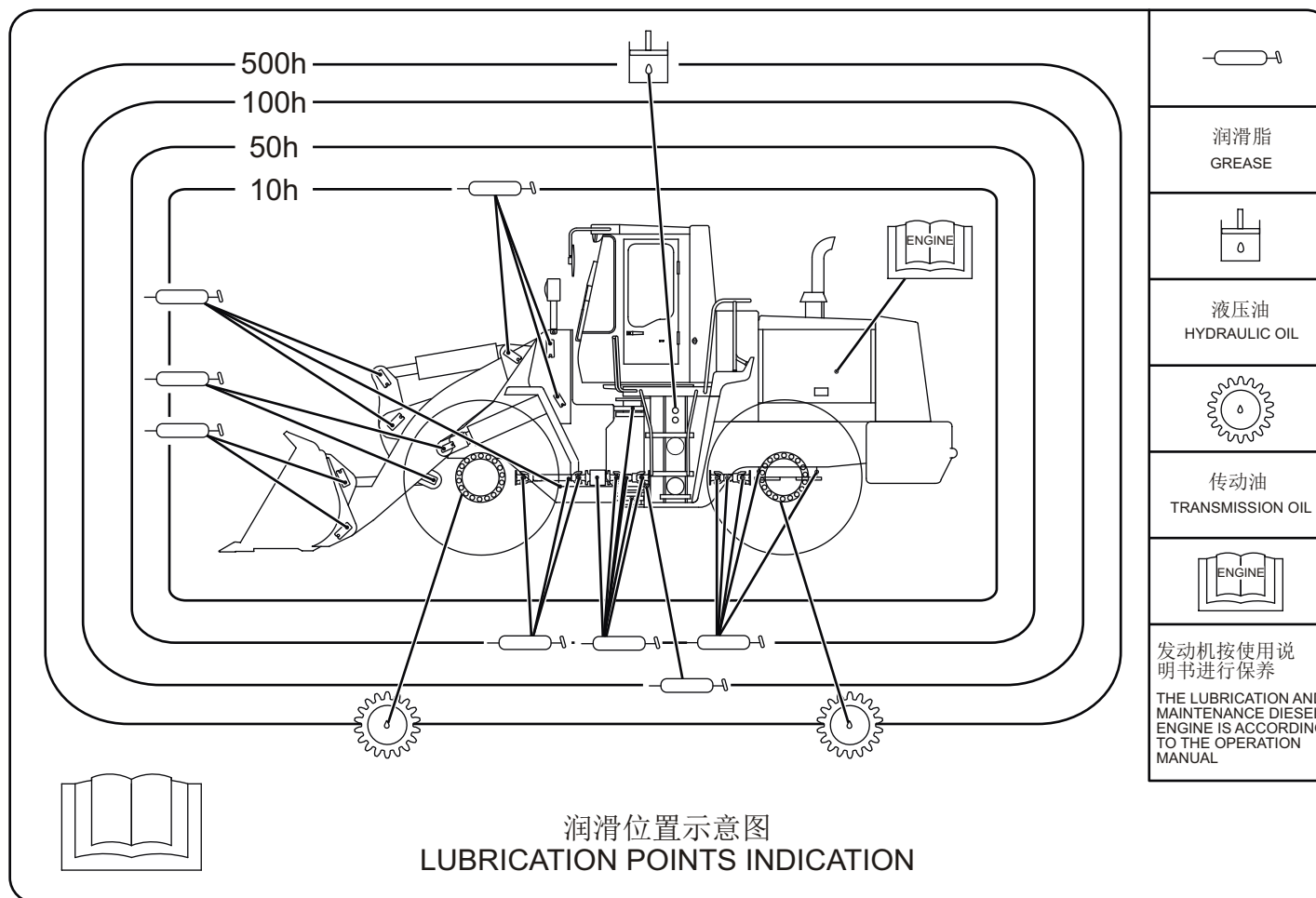

GREASING POINTS INDICATION LAYOUT

