

YUCHAI MACHINERY

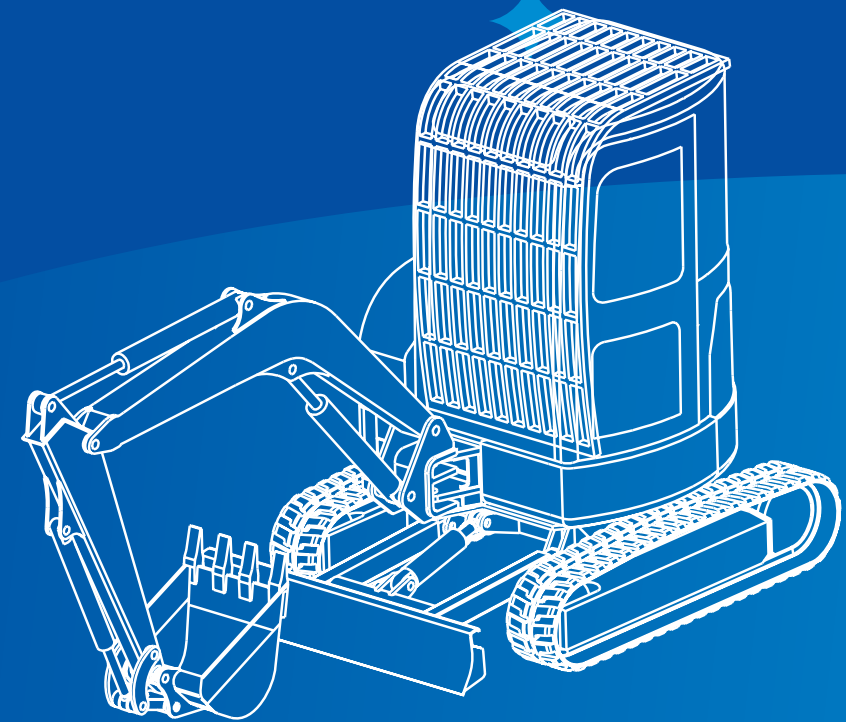

HYDRAULIC EXCAVATOR

YC35SR

OPERATION AND MAINTENANCE MANUAL

GUANGXI YULIN YUCHAI ENGINEERING MACHINERY COMPANY LIMITED

SJ008/835(E)-2007

GUANGXI YULIN YUCHAI ENGINEERING MACHINERY COMPANY LIMITED

Manufacturing Base: 168 Tianqiao Road, Yulin, Guangxi, 537005 P.R. China

Tel: 0086-775-3283502 3283505 3283507 3283510

Fax: 0086-775-3289578

Web-site: www.yuchai-excavator.com

E-mail: export@yuchai-excavator.com



If it operates the machine with wrong way,it will make some dangers.Before use the machine,it should do as follow:

- **Remember the operation manual and the use criterion**
- **Read & understand the content of the user manual about the safety operation**
- **Understand & know the safety sign of the machine**
- **Let the person leave the workplace who not the operator**
- **It should have a safety operation training before operates the machine**

You have the duty to observance the ordinance & laws, follow the relevant direction about machine operation & maintain from YUCHAI.

Contents

1.Prolegomena

To user -----	1-2
Product Information -----	1-3
Machine Direction-----	1-4
Machine Configuration-----	1-6
Technical Data-----	1-7

2.Safety Rules

General Rules-----	2-2
Safety Tips-----	2-3
Safety Equipment-----	2-4
Safety Signs- -----	2-5
Safety of the Workpaace-----	2-13
Operation Safety- -----	2-14
Transport&Loading and Unload---	2-24
Maintain-----	2-25
Fire-proof Explosion-proof& Antigas -----	2-26
Accumulator -----	2-27
Hydraulic System -----	2-29

3.Parts Introduction

Operating Equipment-----	3-2
Combined Digital Instrument-----	3-3
Switch Group Controlling Box-----	3-7
Panel Switch of Right Controlling Box -----	3-9
Safety Lock Part -----	3-10
Work Equipment and Swinging Control-----	3-11
Driving operation-----	3-13
Throttle Lever-----	3-14
Operator Seat-----	3-15

Safety Belt-----	3-16
Air-condition Control -----	3-17
Radio -----	3-18
Door and Window -----	3-19

4.Operation Manual

Preparation before Running Machine -----	4-2
Engine Operation -----	4-3
In & Out Machine -----	4-8
Moving of the Machine -----	4-9
Turning the machine -----	4-11
Rotating the Machine -----	4-12
Operate the Operating Device -----	4-13
Working On The Slope or In The Water -----	4-15
Out of The Muddy Condition -----	4-16
Operating Manual -----	4-17
Take-down & Installing The Bucket -----	4-20
Place The Machine -----	4-21
Check After Completion Work -----	4-23
Transportaion-----	4-24
Operate The Machine Under The Cold/Hot Weather -----	4-28
Long Term Storage-----	4-30
Peason for the Technical Trouble& Resolve -----	4-32

5.Maintenance

Maintenance Information-----	5-2
Maintenance Summary -----	5-4
Oil Choosing list-- -----	5-6
The Tighten Moment -----	5-7
Maintenance List of Time-check -----	5-10

Routine Check -----	5-12
Fuel System of the Engine -----	5-13
Cooling System of the Engine -----	5-17
Lubricating System of the Engine -----	5-20
Air Intake System of The Engine -----	5-22
Other Maintenances of The Engine -----	5-23
Hydraulic System -----	5-24
The Reducer -----	5-32
Support Roller, Carrier Roller& Leading Roller -----	5-34
Crawler -----	5-35
Lubricating -----	5-36
Air-condition(optional) -----	5-37
Replace The teeth of The Bucket -----	5-40
Washing The Plastic Mat of the floor -----	5-41

6.Attachment Manual

Safety Item-----	6-2
Installation & take-down of the attachment -----	6-4
Operation Manual of the attachment -----	6-5
Daily Check of Hydraulic Crush Hammer -----	6-10

Appendix:

Black Manual of The Certification

1

Prolegomenon

TO USER

Dear users,

You are welcome to use YUCHAI excavator, thank you for your support to our business.

This manual is for the operator and the service man of YUCHAI excavator. Hope you can read this manual carefully before operating and maintaining, and work strictly as the regulations of safety measures, operating guides, lubrication and periodic maintenance.

Correctly handle the operating method and maintain frequently are the necessary measures for the machine work reliably and efficiently, and also can lengthen machine use life.

Please send the machine to our company's service office or agent for important servicing and adjustment, and use the original parts supplied by our company. It will cause many problems if you install other parts on our machines even it is not clear effect for beginning.

We will not supply the warranty service if the machine broken as Used the unoriginal parts or repaired by the service department which is not authorized by Yuchai even it is during the warranty period.

According to the principle of "The customer is god", we will keep improving the machine for supplying the product to the user as best as we can. The improvement will be take in any minute, we will not responsible for sending the new manuals for the selling products and giving the notice in advance.

Hope this machine can supply the comfortable operating condition.

Product Information

If you want to know the basic information of the machine, please check the following picture:

● **Machine Information(The nameplate is on the left-front side of the platform)**

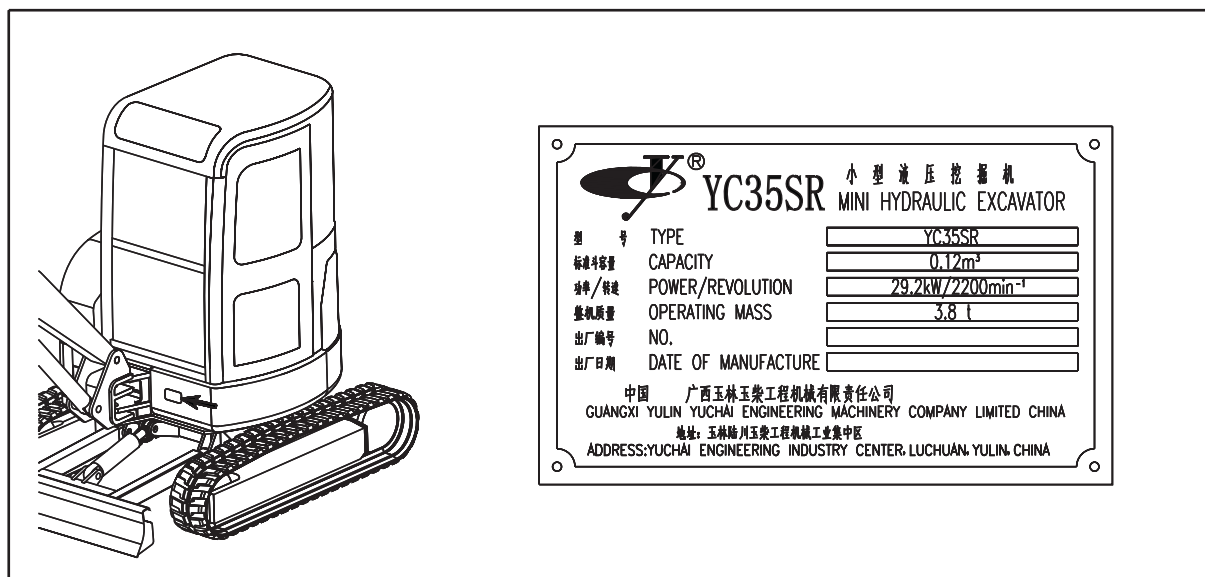

● **Engine Information(The nameplate is in the middle of the engine)**

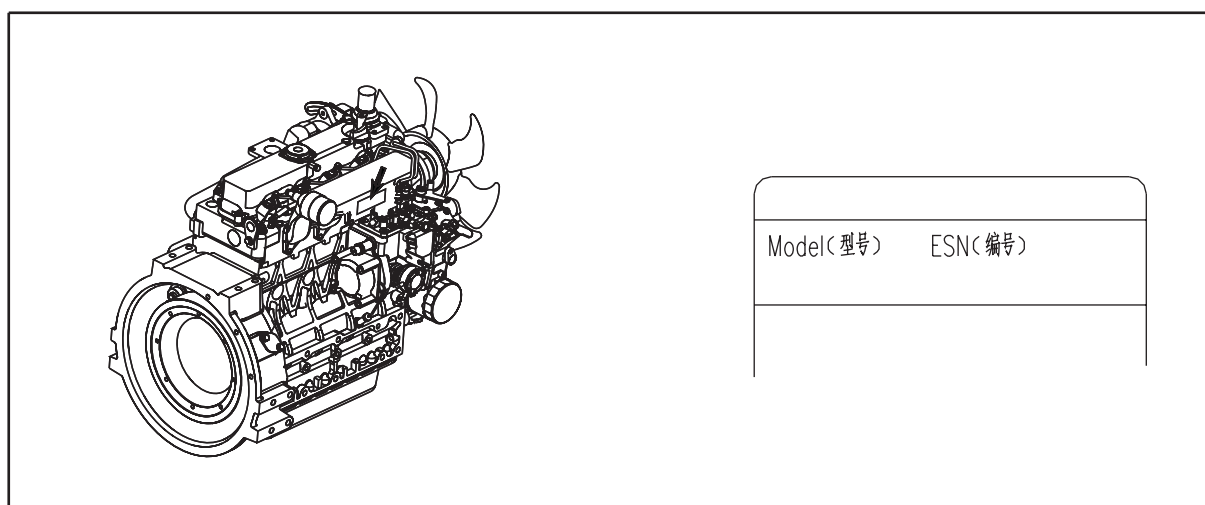

● Machine running Information(The time meter of the engine is on the digital instrument which is inside the cab)



Machine File

Please fill the machine series No. and engine series No. in the following table. If you need to buy the spare parts or related information, please advice YUCHAI these series numbers.

	<ul style="list-style-type: none"> ● Model: _____ ● Machine No: _____ ● Engine No: _____ ● Dealer Information: _____ _____ _____ _____
---	---

Machine Direction

Front, back, left, right, top, underside in the manual same as the direction as follow:

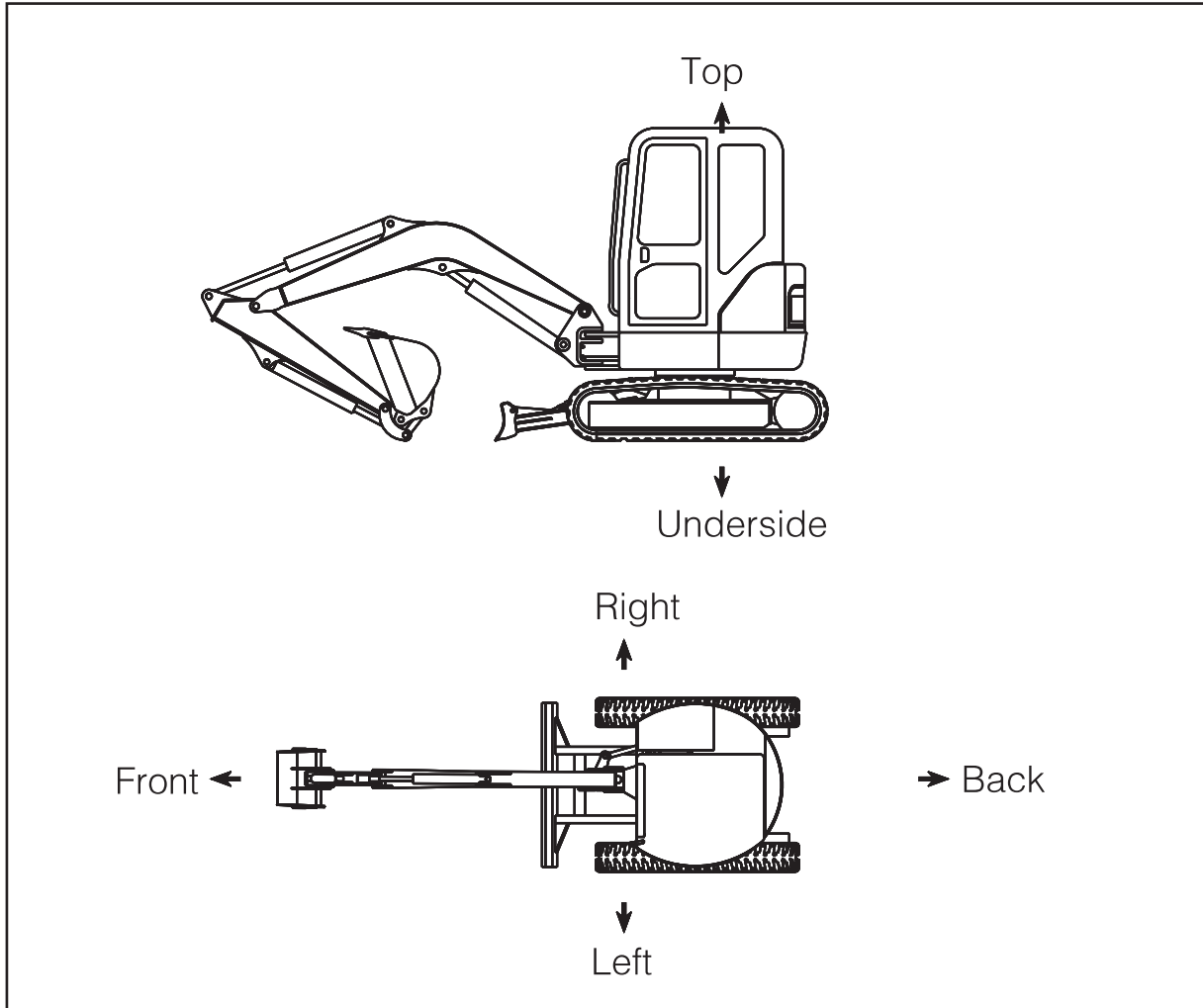

Machine Configuration

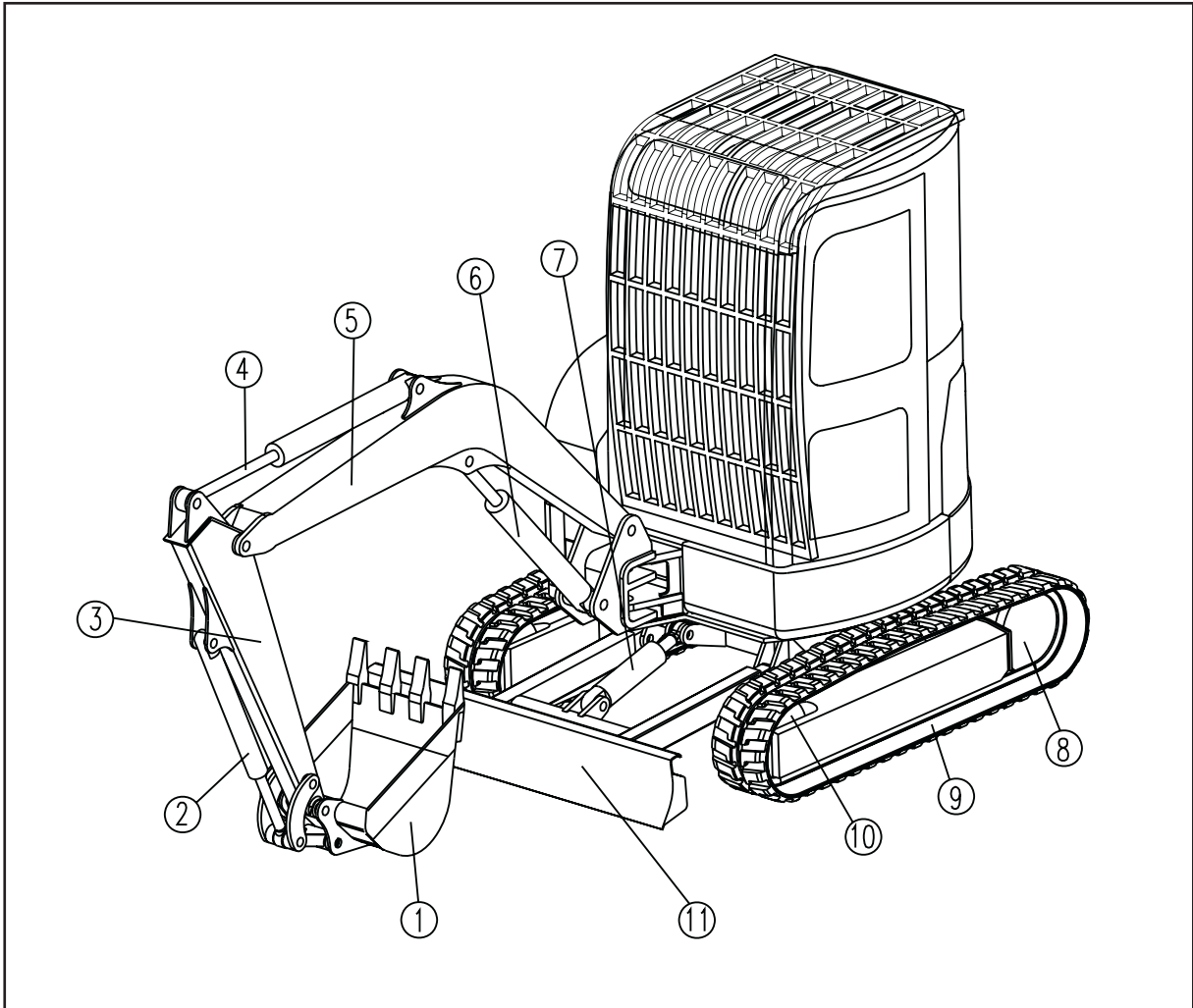

1. Bucket

2. Bucket cylinder

3. Arm

4. Arm cylinder

5. Boom

6. Boom cylinder

7. Dozer cylinder

8. Driving wheel

9. Crawler

10. Front Idler

11. Bull dozer plate

Technical Data

1.Dimension parameter

Code	Item	Unit	YC35SR
			835
	Operating Weight	Kg	3800
	Standard bucket capacity	m ³	0.12
	Name of engine		KUBOTA V2203
	Power of engine	KW/rpm	29.2/2200
A	Length	mm	4650
B	Height	mm	2550
C	Overall width	mm	1800
D	Width of padrail	mm	300
E	Rotating radii of platform	mm	900
F	Length of padrail	mm	2100
G	Distance of roller	mm	1620
H	Height from floor	mm	350
I	Height of moving-arm end	mm	1510
J	Width of the platform	mm	1740
K	Height of engine cover	mm	1425
L	Height from floor of platform	mm	575
	Width of bucket	mm	638
	Driving speed(low/hight)	Km/h	2.4/4.3
	Rotating speed of platform	rpm	11~13
	Cab		●
	Lookum		●
	Deflection angle(left/right)		
		0	54 ⁰ /80 ⁰

Note:Technical data are subject to replace without prior notice!

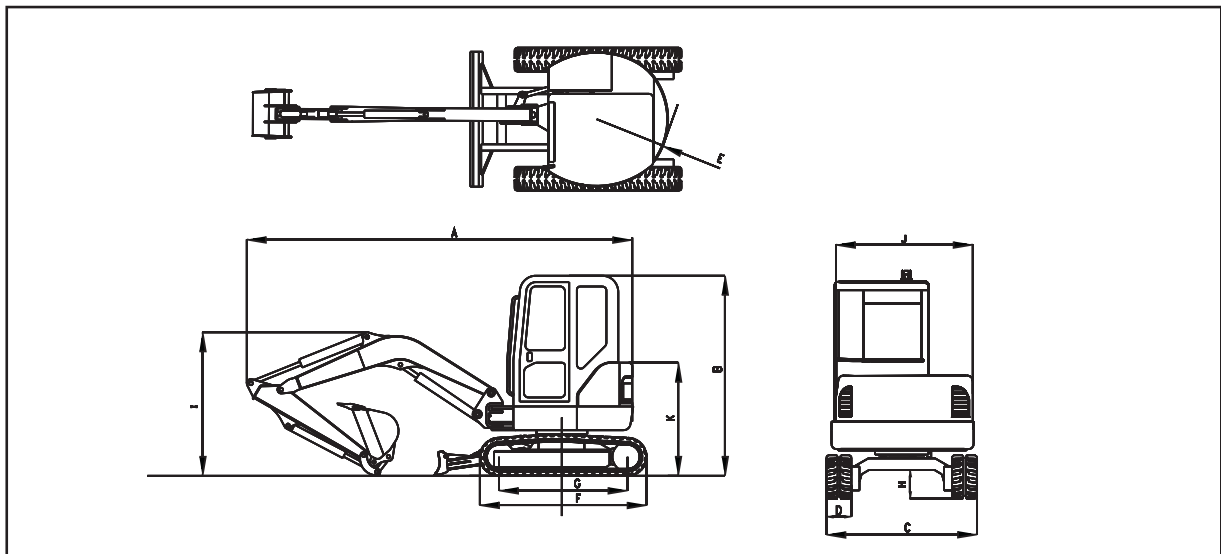

2.Operating parameters

Code	Item	Unit	YC35SR
			835
A	Max. digging height	mm	5100
B	Max.height of load&unload	mm	3630
C	Max. digging depth	mm	3120
D	Max. digging radii	mm	5460
D1	Max.digging distance of level floor	mm	5340
E	Digging radii of Max.digging height	mm	2948
F	Min. rotating radii	mm	2210
G	Max. bucket depth of Bulldozer	mm	450
H	Max. uplift height of Bulldozer	mm	389
	Max.dig power	kN	25.7

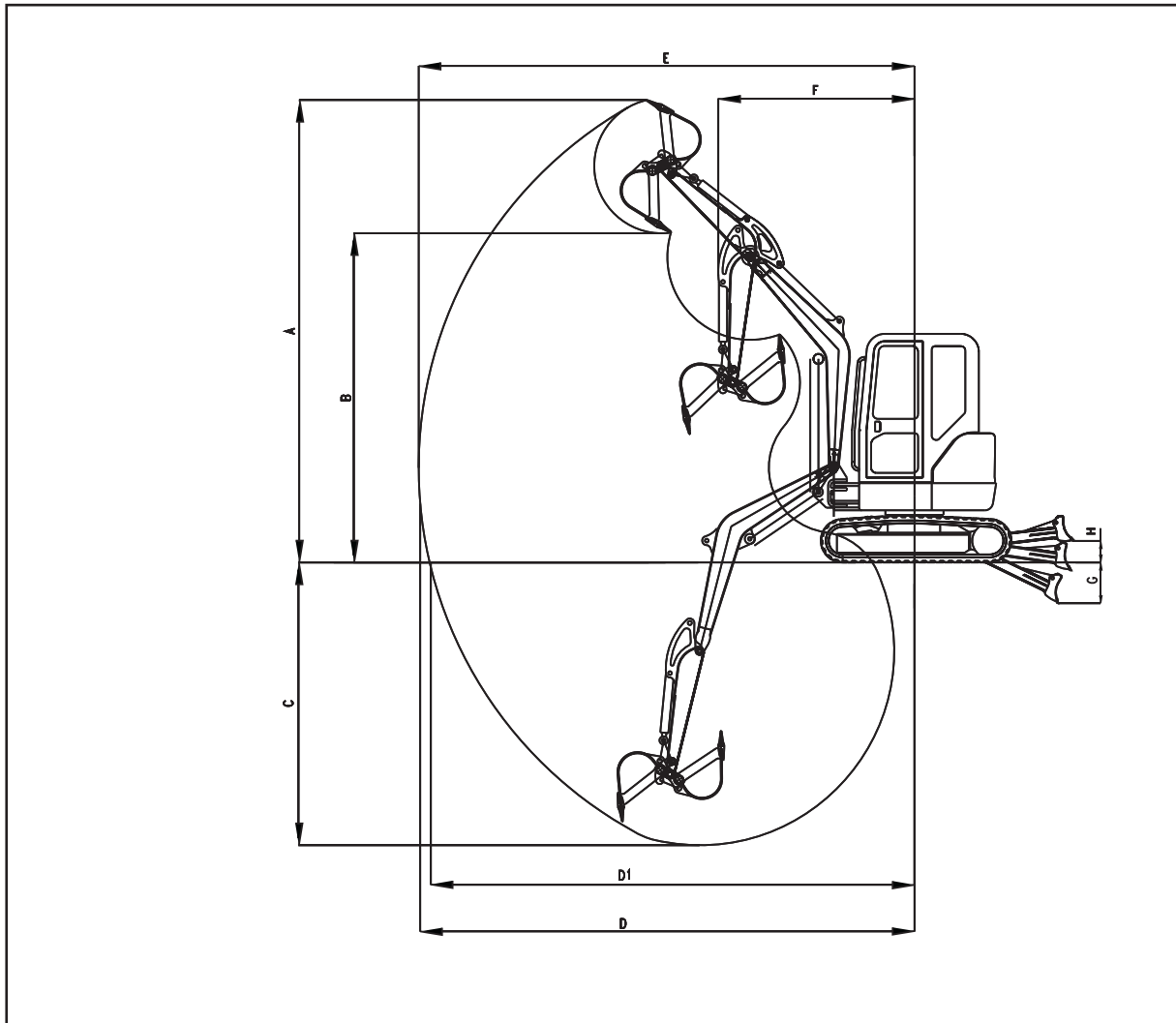

Note: Technical parameters are subject to change without prior notice!

3. Bucket

SN.	Capacity(m ³)	Bucket Width(mm)	Bucket Weight(kg)	Bucket teeth .
1	0.12	593	100	4

4. Traveling system

Traveling system is combined by Hydraulic traveling motor and multiple-planetary reducer, reducer is inside the crawler.

	Walking speed(km/h)	Max. pull force (kN)	Gradeability
High speed	4.5		58%(30°)
Low speed	2.4	2800kg	

5. Hydraulic system

Advance throttle hydraulic system

Main valve: Imported multiple valve

Pressure (mpa): 21mpa

Oil return filter: 10 um

Oil intake filter: 5 um

6. Electric system

Voltage: 12V

Battery: 80AH

2

Safety Rules

General Rules

Almost accidents about machines operation and maintenance will be avoided as per the related safety rules of this manual. It is required to read this book and all the safety information before the machines operation and maintenance.

The related safety contents of the manual indicate the possible things made during the machines normal run, and give the methods to solve it.

The related safety contents can see from the integrative guidelines of each chapter, including the contents of this chapter.

This manual shall not include all the potential risks and related solving methods. It is your responsibility to adopt the methods and keep safety if you use the methods and actions that not allowed in this book.

The Forbidden purposes and operations of this manual shall never be done in any circumstance.

This excavator shall be operated and maintained by trained and qualified persons.

It is required to check each function of the machines before work, and look for the reasons if finding the malfunction. It only can work after being repaired.

The machines shall be checked and maintained according to the manual. And the operators are required to follow the operation ways and safety regulations in the work scope.

Under the condition of alcohol and medicines, it is not allowed to operate and maintain the machines.

It is required to learn the expressive contents of related signals and gestures

It is required to know and obey the related laws and regulations of the countries or the regions when being on the road.

The machine can be operated only if make sure nobody around the work area.

Safety Tips

1.Warning sign



The sign in this manual indicates the important information about safety. You should carefully read the information and advice followed when you find this sign, to avoid the casualty accidents.

2. Safety Tips

The manual provides the security notices, signs and potential dangers conditions, the operators are required to carefully read this manual and the attached signs on the machines, and should work as per the related process.

The safety tips of this machine shall be expressed as: Danger, Caution and Notice, the explanations of these words are as follows:

Danger: It indicates that it can lead to casualty and serious hurts if the danger happens. It only appears in the most dangerous occasions.

Caution: It indicates that it can lead to casualty and serious hurts if the potential danger happens.

Notice: It indicates that it may lead to lower and medium hurts if he potential danger happens. And it can also give the advice of risky operation.

Safety Equipment

1. The safeguard for the operator

1) Operators should wear the skintight and suitable work clothes, safety helmets, work shoes and other related protective equipment before operation and maintenance work. (For example: Protective earplugs, grooves, protective glasses, safety belts and so on)

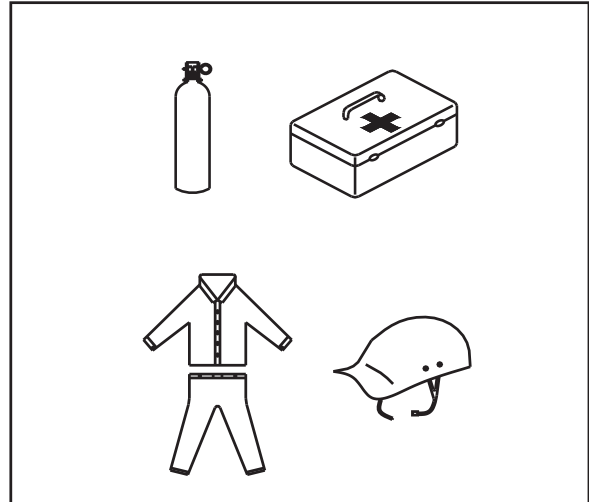

- 2) Long hair should be fastened and covered with safety helmets to prevent entanglement with any rotating.
- 3) Users should arrange the first aid medicines in the machine, check them periodically, and arrange more medicines if necessary.
- 4) It is required to check if the protective equipment are in normal before operation and maintenance work.

2. Escape Hammer and Fire Extinguisher

Escape hammer and fire extinguisher shall be installed in the driver's Cabs. It is required to hit the glass with hammerhead if the driver is trapped in cabs, under this condition, the driver shall notice to protect the eyes and face. It is required to put out the fire with the fire extinguisher if there is fire in cabs. It is required to read the users' manual of fire extinguisher carefully, and follow the requirements strictly. It is required to check and maintain fire extinguishers periodically.

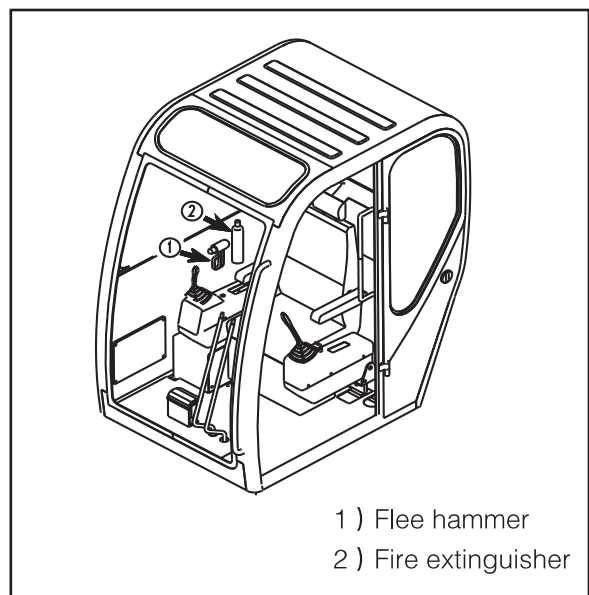

Safety Signs



Warning: Ignorant of safety signs or safety signs lost may lead to the casualty. Please replace the lost and damaged signs in time, and keep them clean.

Read the manual and caution signs attached on the machine before operation and maintenance work, and make sure to know and follow the contents.

Check the signs before operation every day, and clean them if dirty.

It can only use the calico, water and soap during the cleaning work. It is forbidden to use organic dissolvent or gas, because they can make the signs shed.

The signs shall be replaced if they are damaged, lost or unclear. New signs shall be attached on the new parts replaced. It can ask Yuchai agents for new safety signs.

1. Classifications of Safety Signs

Safety signs in this manual and on the machines shall be divided into: safety signs with picture and safety signs with picture & character

A. Safety Signs with Picture

This kind of safety sign can easily and clearly express the caution information with pictures.

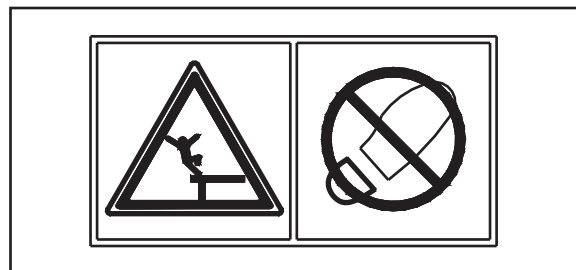

2.The way of the safety sign

The sign is the picture only show the “Safety sign” part of the sign,other will show in next section.

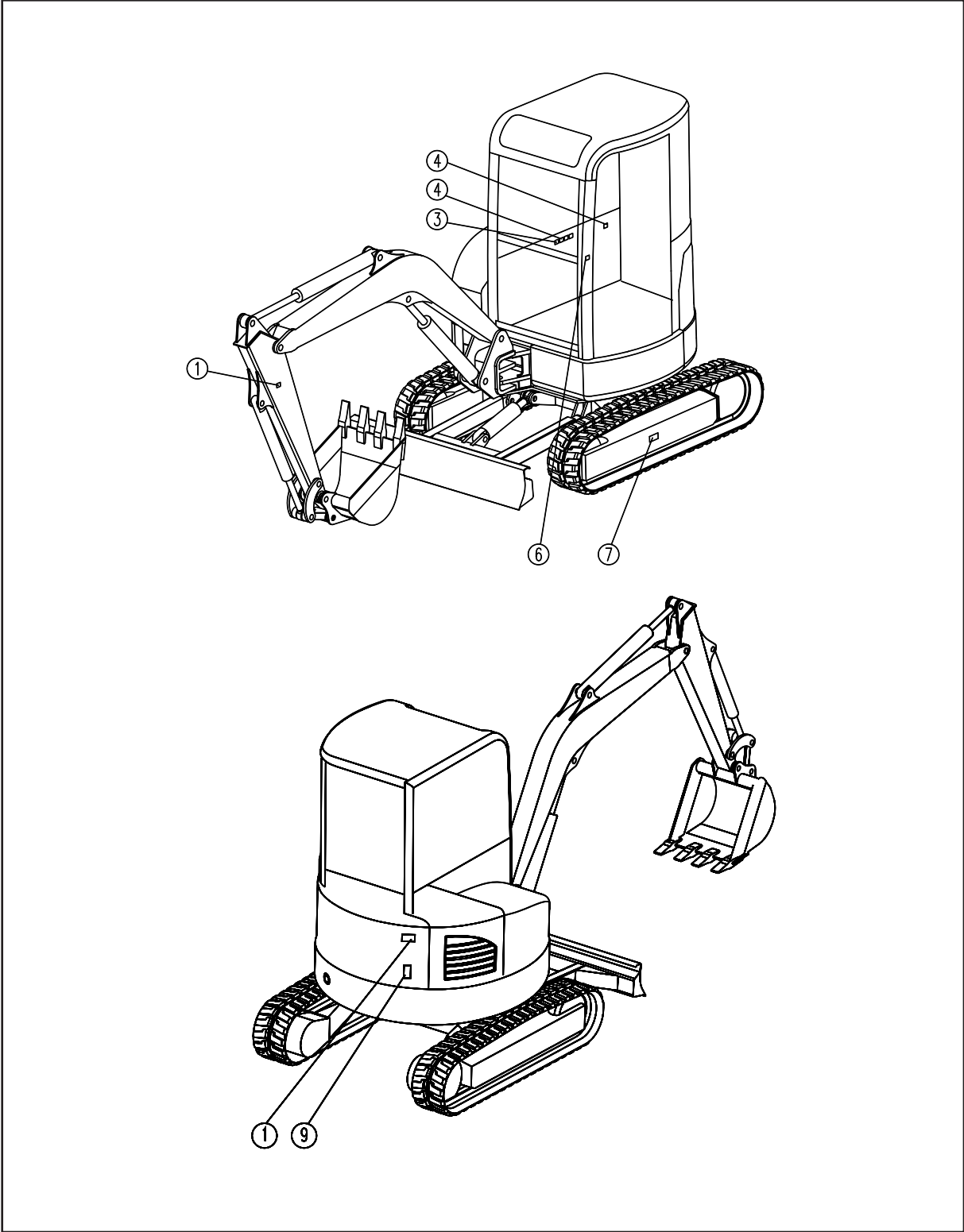

3 The position of the warning plates

1) Make sure do not run over people

The moving machine will hurt people.

Please keep safe distance from the machine

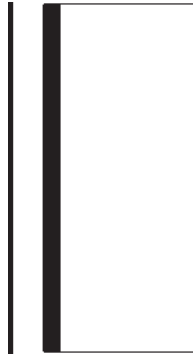

2) Precaution to lock the front windows when open it.

The unlock windows may suddenly fall down and hurt the people by machine shaking or other strength from outside.

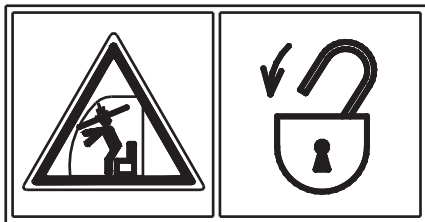

3) Please pay attention when up and down.

Please use the step and plates of the crawler,hold the bar and slowly get in the machine.



4) The notice of Escape hammer when in emergency.

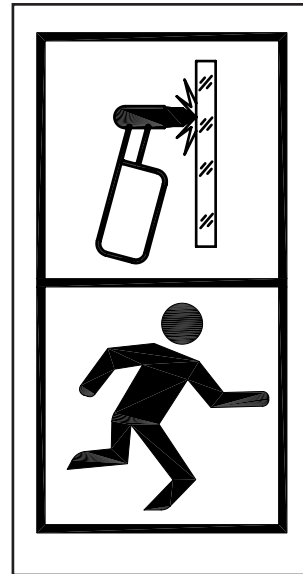

5) There might be spur the Hight-pressure hydraulic oil out from the tension assemble when adjust the tension pressure.



6) Waning plates.

 WARNING	
<p>PLEASE CHECK THE HYDRAULIC OIL LEVEL, ENGINE OIL LEVEL, COOLANT LEVEL BEFORE STARTING THE ENGINE.</p> <p>DRAIN THE WATER AND DEPOSIT IN THE OIL-WATER SEPARATOR EVERY DAY.</p> <p>LUBRICATING SYSTEM WARNING</p> <p>1. USE THE STANDARD ENGINE OIL THAT WAS NOT LOWER THAN CF.</p> <p>2. SUGGEST TO CHANGE ENGINE OIL AND ENGINE OIL FILTER PER 200 WORKING HOURS .</p>	<p>EVERY OIL CHANGING OR ENGINE OUT OF START WITHIN 30 DAYS,THE INITIAL ENGINE STARTING SHOULD BE NOTED:</p> <p>1.DISCONNECTED THE WIRE FROM THE FUEL INJECTING PUMP ELECTROMAGNETIC VALVE;</p> <p>2.TURNING THE CRANKSHAFT BY STARTING MOTOR TILL THE COMPRESSING WAS SHOWED ON THE INSTRUMENT OR THE ENGINE OIL WARNING LAMP WAS OFF;</p> <p>3.CONNECT THE WIRE WHICH IS LED TO THE FUEL INJECTING PUMP ELECTROMAGNETIC VALVE;</p> <p>4.START THE ENGINE BY USING THE STARTING MOTOR.</p>
<p>COOLANT SYSTEM WARNING</p> <p>1. PLEASE USE THE COOLANT AT ANY WEATHER.</p> <p>2. FILL IN THE WATER TANK WITH COOLANT TILL IT WAS REACHED THE BOTTOM OF INTAKE TANK COVER.</p> <p>3. MAKE SURE THAT THE WATER TANK COVER IS FIXED WHEN USING THE ENGINE.</p>	<p>AIR-INTAKE SYSTEM WARNING</p> <p>1. CHECK THE AIR-INTAKE SYSTEM PIPE AND HOOP, RUBBER SEAL AND FILTER PAPER, ENSURE THAT ALL KEEP IN GOOD STATE.</p> <p>2. CLEAN THE AIR FILTER ELEMENT PROPERLY ACCORDING TO THE STATUS OF AMBIENT CONDITION AND AIR FILTER BLOCK ALARM.</p>

7)It's forbidden to open the container's cover when Hydraulic oil or coolant are in high temperature



10)It's forbidden to start the engine by shorting alalternator.



11)Precaution the engine,radiators,muffler and some other hot or pressurized components.



8)Warning plates.



12)Hand,arm,skin and clothes may be damaged by blade fan or fan belt so never touch them if the are moving.

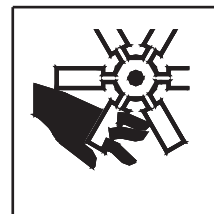

9)Please stop the engine when adjust the inner assembly of the machine.



13)It's forbidden to disassemble,drill and cut off the accumulator and air-spring. Those equipment is including the Hight-pressure air.

The wrong operation will cause human hurt.

Please ask the skillful people deal with such problem.



14) Please check the Operation Manual and file before maintenance.

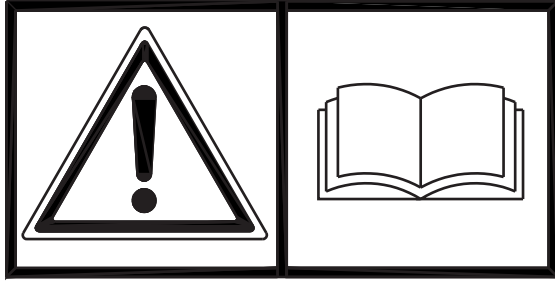

17) The warning plates for Electric shock.

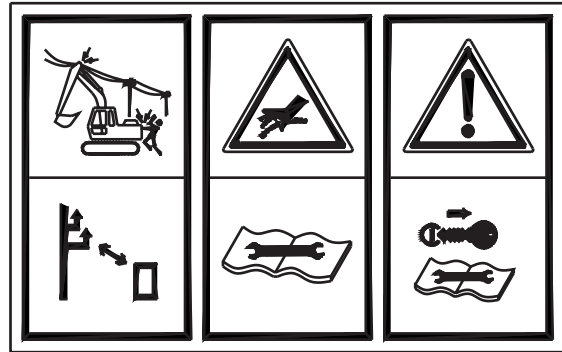

15) Warning plates on left box.

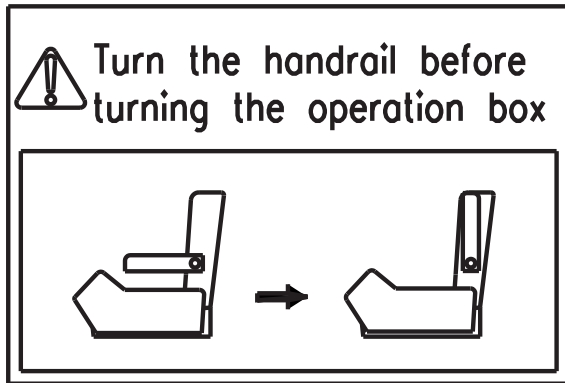

18) The system warning plates.

WARNING	
<p>PLEASE CHECK THE HYDRAULIC OIL LEVEL, ENGINE OIL LEVEL, COOLANT LEVEL BEFORE STARTING THE ENGINE.</p> <p>DRAIN THE WATER AND DEPOSIT IN THE OIL-WATER SEPARATOR EVERY DAY.</p>	<p>EVERY OIL CHANGING OR ENGINE OUT OF START WITHIN 30 DAYS, THE INITIAL ENGINE STARTING SHOULD BE NOTED :</p> <ol style="list-style-type: none"> 1. DISCONNECTED THE WIRE FROM THE FUEL INJECTING PUMP ELECTROMAGNETIC VALVE; 2. TURNING THE CRANKSHAFT BY STARTING MOTOR TILL THE COMPRESSION WAS SHOWN ON THE INSTRUMENT OR THE ENGINE OIL WARNING LAMP WAS OFF; 3. CONNECT THE WIRE WHICH IS LED TO THE FUEL INJECTING PUMP ELECTROMAGNETIC VALVE; 4. START THE ENGINE BY USING THE STARTING MOTOR.
<p>LUBRICATING SYSTEM WARNING</p> <ol style="list-style-type: none"> 1. USE THE STANDARD ENGINE OIL THAT WAS NOT LOWER THAN CF. 2. SUGGEST TO CHANGE ENGINE OIL AND ENGINE OIL FILTER PER 200 WORKING HOURS . 	<p>AIR-INTAKE SYSTEM WARNING</p> <ol style="list-style-type: none"> 1. CHECK THE AIR-INTAKE SYSTEM PIPE AND HOOP, RUBBER SEAL AND FILTER PAPER, ENSURE THAT ALL KEEP IN GOOD STATE. 2. CLEAN THE AIR FILTER ELEMENT PROPERLY ACCORDING TO THE STATUS OF AMBIENT CONDITION AND AIR FILTER BLOCK ALARM.
<p>COOLANT SYSTEM WARNING</p> <ol style="list-style-type: none"> 1. PLEASE USE THE COOLANT AT ANY WEATHER. 2. FILL IN THE WATER TANK WITH COOLANT TILL IT WAS REACHED THE BOTTOM OF INTAKE TANK COVER. 3. MAKE SURE THAT THE WATER TANK COVER IS FIXED WHEN USING THE ENGINE. 	

16) Lock-plates.

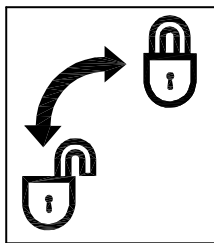

operation box lock-in

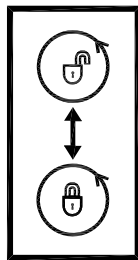

platform lock-in

19) Sign of transfuse the hydraulic oil.

<p>HYDRAULIC OIL</p>	<p style="text-align: center;">NOTICE</p> <ol style="list-style-type: none"> 1. PLEASE REPLACE THE HYDRAULIC OIL AND CLEAN THE FILTER EVERY 800 HOURS. 2. PLEASE REPLACE THE FILTER ELEMENT FOR OIL RETURN EVERY 400 HOURS. 3. PLEASE SELECT L-HM68 TYPE HYDRAULIC OIL.
-----------------------------	---

20) Sign of transfuse the fuel oil.

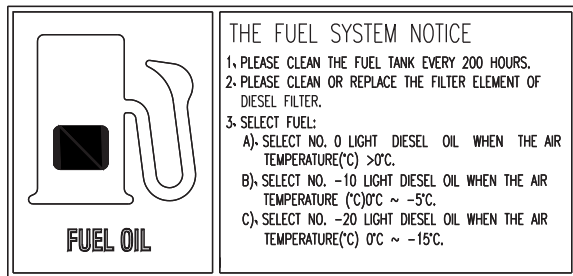

23) Accelerograph Mark.

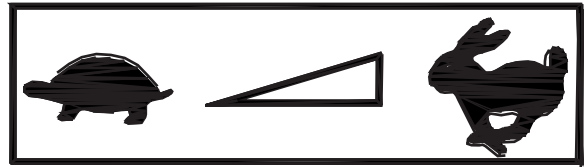

21) Lubricate mark

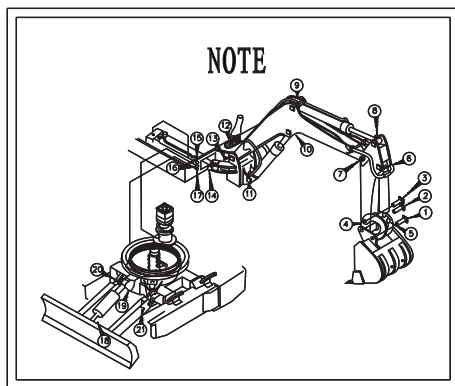

24) Sign of Reading Manual.

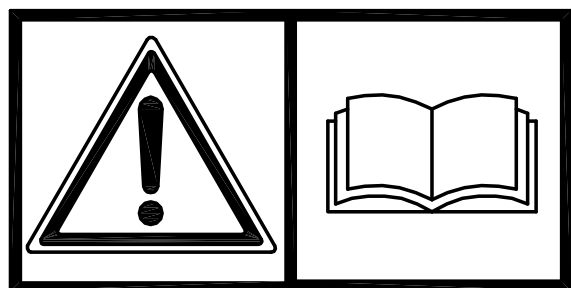

22) Hook mark.

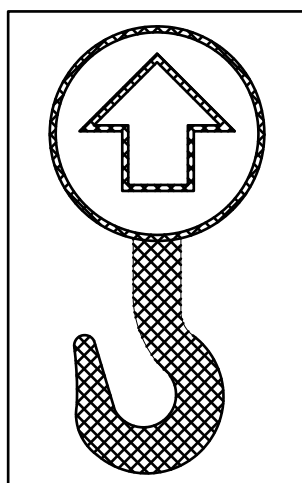

25) Noise Volume Mark (For Export).

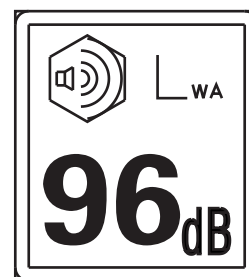

26) CE Mark



27) Grab Hook Mark.

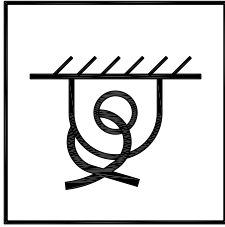

30) The sign on stern.



28) The sign of center of rotating.

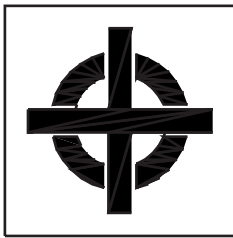

31) Binding sign.

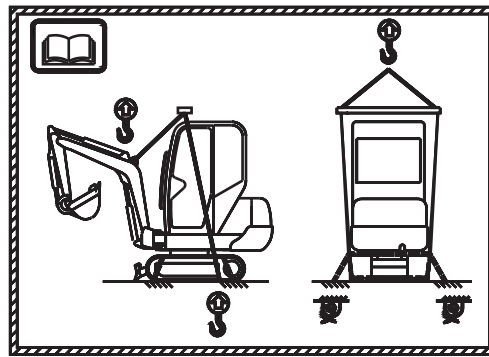

29) The sign of adjust Dozer and chassis

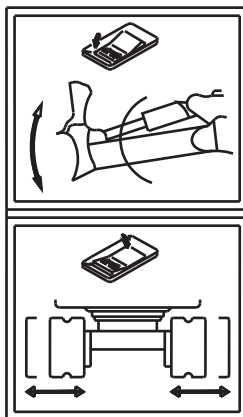

32) Door Lock mark.

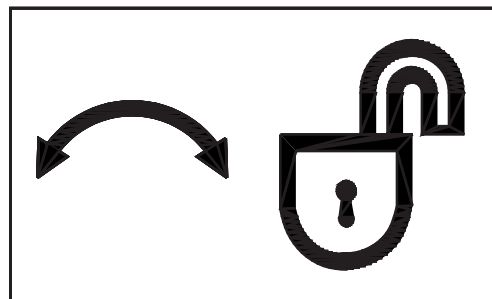

33)Escaping sign.

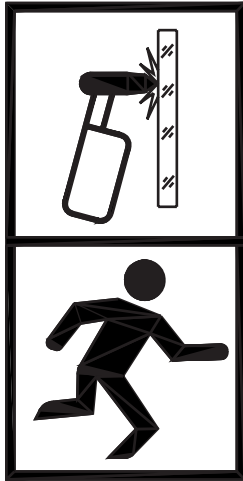

36)Maintenance Warnign Sign.

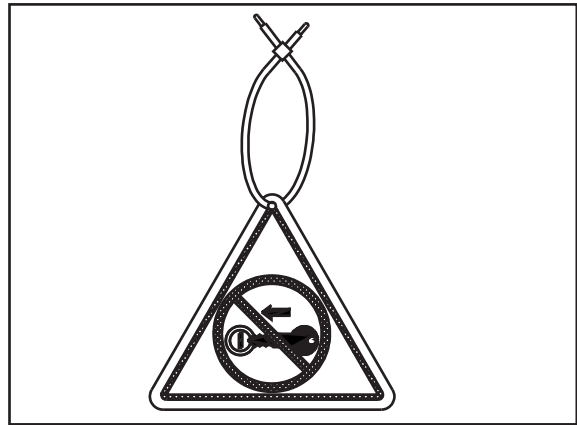

34)Release oil sign

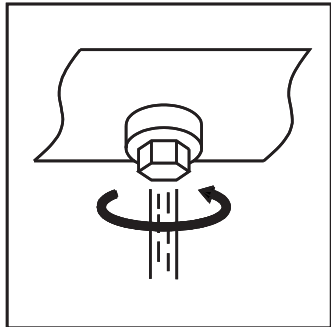

37)Glisten Sign

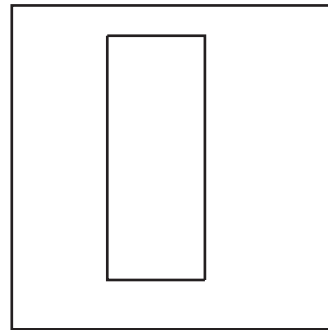

35)The sign of forward

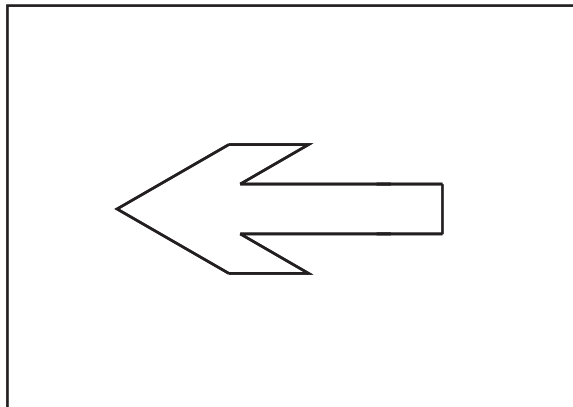

38)The sign of change gear

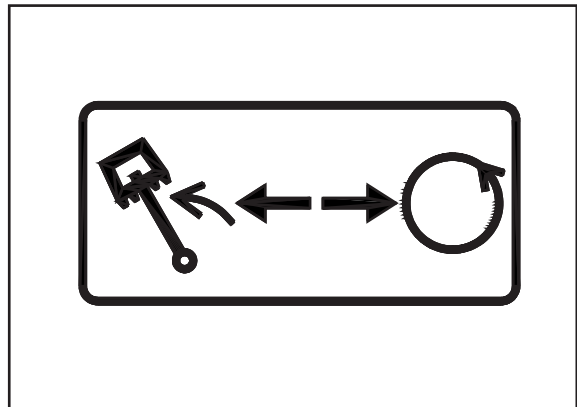

Safety of The Workplace

As far as possible to know the workplace, please check as follow:

- 1.The place of slope
- 2.The hole
- 3.The hanging
- 4.The agrotpe(soft or hard)
- 5.The plash or the fenland
- 6.The rock or stub
- 7.The groundsill which buried,the limit of the stub or wall.
- 8.The garbage which buried or the limit of the filling
- 9.The hole、 the roadblock、 the mud、 the water
- 10.The traffic
- 11.The dust、 the smother、 the fog
- 12.The place of the electric、 gas、 phone、 water、 sewage which hang or buried

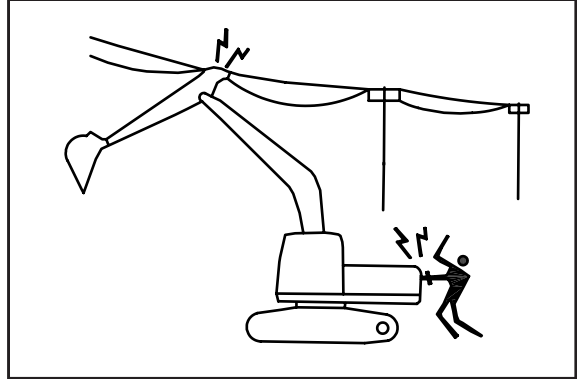

Warning:Before digging,please contact the public establishment service system or sector

- 13.When operating the machine in the building,you need to know the space of the door, aisle,the bearing capability of the floor.
- 14.Know the distance of the wire、 the line &the machine、 the machine & the floor.If possible,it's better to cut off the power.



Warning:Touch or close the power or close the machine which connect the power will shock.No let any part of the machine close the power line except have the preventive.

- 15.Keep the min.legal distance of the gas-main、 the cable、 the line、 water pipe



Warning:If you see the end of the broken cable,the cutting cable will hurt your eye.

Operation Safety



Warning: Before running the machine, please tie the safety belt, ring the trumpet, and confirm nobody in the workplace.

1. Start the machine

A. Safety detailed rules of start engine

- 1) Before to start the engine, it need to ring the trumpet.
- 2) Except the operator, it doesn't allow somebody to hitching
- 3) It only allow the operator sit on the seat to operate the machine
- 4) It's not allow to start the engine by short start motor.
- 5) In the cold day, the machine need to warm-up

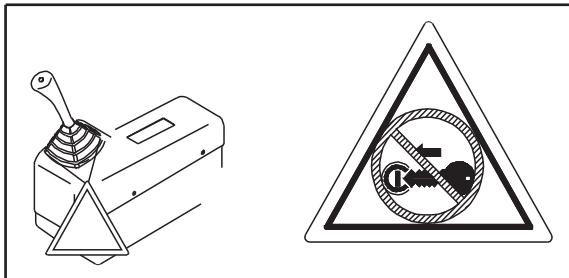

Warning: If the operation handle hangs the sign: no start the engine, it doesn't allow to start the engine

B. After start the engine

After start the engine, it needs to check the things as follow:

- 1) Whether tie the safety belt
- 2) Whether the part running well, like the operation device, the bulldozer, the driving device, the rotating device, the operation device deflecting
- 3) Whether the sound, the libration, the smell, the instrument are well
- 4) Whether the machine oil or the fuel leak

2.Travelling and rotating

1)Before the machine driving, please turn the top of the platform to the right way, make the operating device and the bulldozer to the same direction. If they don't the same direction, the operation will opposite

2)Before the machine driving &rotating, please ring the trumpet to warn the people

3)The digger operated on the hand ground which the width must more than 1.5 times.

4)Before driving, please lock the cab's door. The cab's window allows to open, but it needs to lock.

5)Before back off or rotating, if it not see the back, it need arrange the signal compere

● Safety rules of driving

1)when the machine drives on the flat road,it need to reduce the moving–arm, retract the lever,keep the best way for the barycenter, keep 40–50mm distance for the bucket with the ground.

2)When the machine drives on the uneven road,it adopts the low speed driving,and not allow to turn the machine.If do it,may be lead the machine overturn.

3)The machine doesn't drive on the roadblock which lopsided,it will lead the machine overturn.

4)When the machine drives or operates, it must keep a distance with the people、the building and other machines

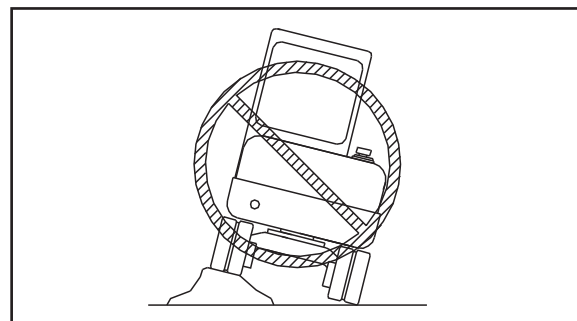
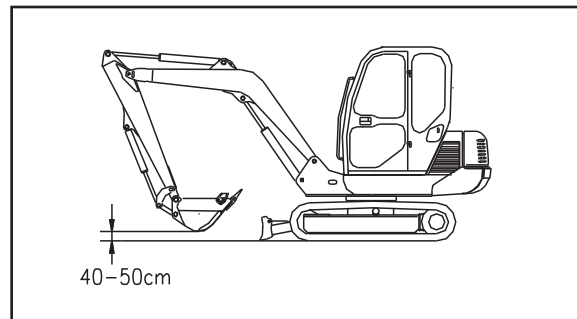
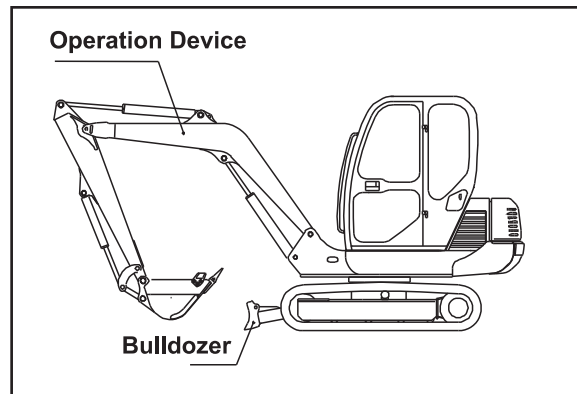

- 5)When the machine drives on the area which have the underpass、 the bridge、 the cable,it need have the sign command,keep a distance
- 6)Upgrade or downgrade,it need lock the platform
- 7)When the machine overpass the bridge、 the building、 the bearing,it should confirm whether they can bear the weight of the digger.
- 8)If the machine needs to drive on the calzada,it need to ask the local traffic section.

3.Driving or operating on the slope

It is dangerous to driving、 operating on the slope.Be care!

1)It suggests not upgrade or downgrade on the slope which the gradient more than 20°

2)When the machine works,it need to tie the safety belt especially on the uograde or downgrade and the danger area

3)When the digger upgrades, the drive wheel need towards the direction which under the slope. It should let the moving–arm、 lever with the slope parallel, the gear of the bucket have 20–30cm distance from the ground. And lock the platform then upgrade low speed.

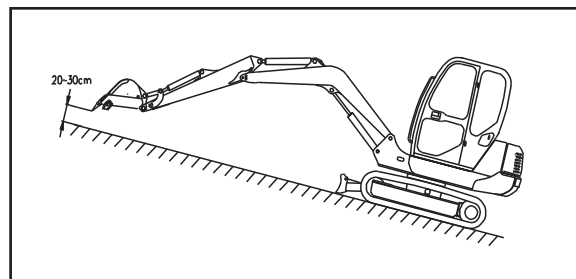

4)When the digger downgrade, it locks the platform. The drive wheel need towards the direction which up the slope. Elongate the moving–arm、 lever , and the gear of bucket have 20–30cm distance from the ground, then downgrade low speed.

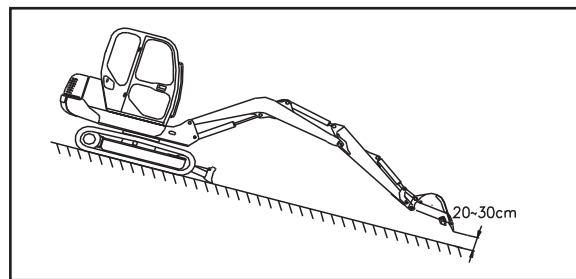

5)No allow to swerve on the slope or pass the slope, it must replace the machine's place on the next flat place, Then upgrand.

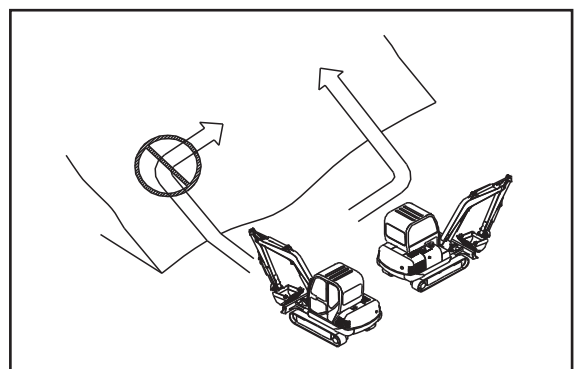

6)When the machine operates on the slope,it must start the high first ,then towards the direction of the downgrade. The Bulldozer back it,and press the ground,the place for remove the soil on the direction of the upgrade.

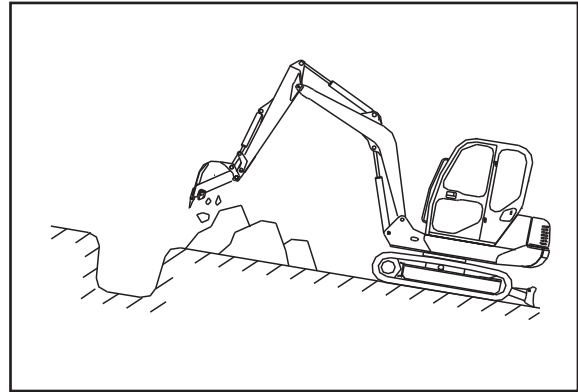

7)It need drives low speed on the lea、 the shatter 、 the wet armor plate

8)No allow to swerve when the machine upgrade or downgrade. Otherwise, the machine maybe overturn.

9)When the machine stops on the slope,it must make the bulldozer into the ground, and make the bucket into the groud,too. After it stop placidly,then stop the engine, and the operator out.

10)No driving or operating on the slope which the portrait gradient more than 25°

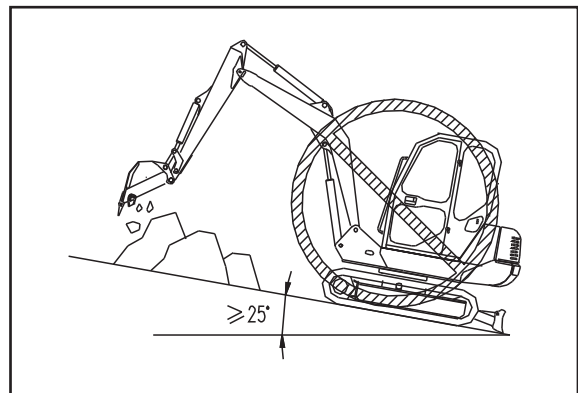

11)No driving or operating on the slope which the landscape orientation gradient more than 15°

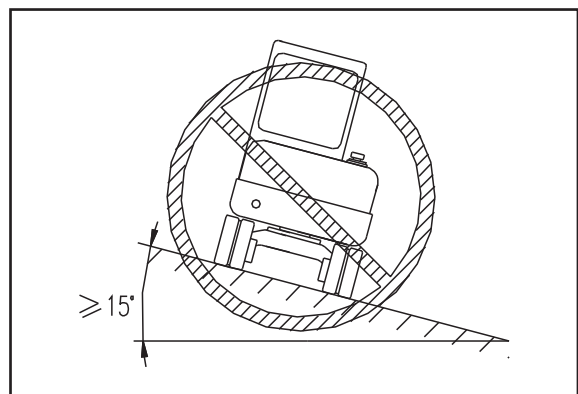

12)As far as possible to keep the machine balanceable,no driving on the rock or over the roadblock.

13)No swerve on the slope.

14)On the slope,the engine and the hydraulic oil must warm-up.

15)When the pedrail and the slope is 90° ,the machine is very dangerous if it rotating.If the machine must rotating,it should make the bucket close the ground, near the machine body,the padrial towards the top of the slope,and rotating low speed.

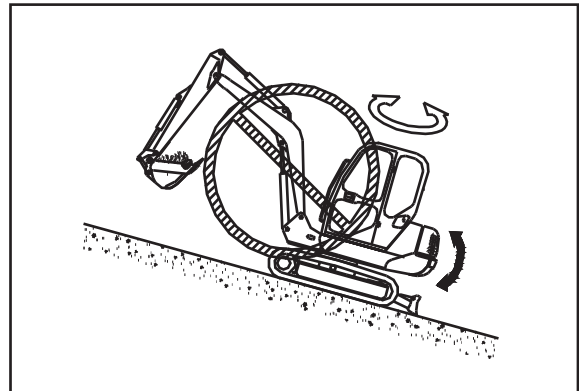

16)When the machine operates on the slope,operating the rotating or operation device, the machine maybe overturn.

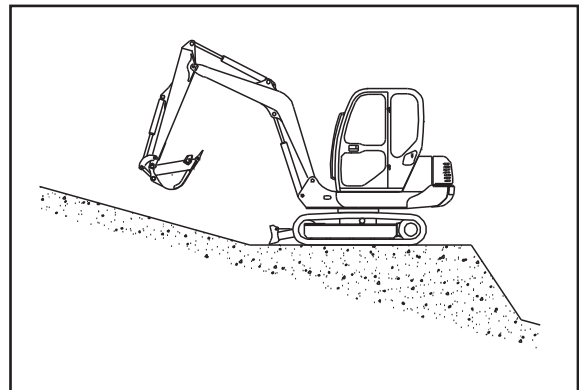

4.Safe to operation



Warning:the operation must remember the operation handles to avoid the wrong operation.



Warning:the wrong operation will make the machine overture. Remember the information can make a right guide to protect the body.

1)Before operating,it should remove all the things and the people.

2)To confirm the workplace can bear the machine,then let the machine enter.

3)As far as possible the two pedrails in the same plane,then it can operate.

4)To confirm the workplace no cable、 no windpipe、 no water pipe,the machine starts

5)When the machine back off,it should observe whether the moving line regular, whether it has the roadblock

6)When the bucket has the special resistance,it doesn't allow to driving or rotating.Otherwise,the machine broken.

7)When the machine operated,if the hydraulic oil tank reach the end–point of the driving,the power will act on the limit ring of the oil tank.It will reduce the use life of the machine.To avoid the case,when the hydraulic oil tank operated,it should have a little value.

8)When the machine digs deep,it need to avoid the bottom of the moving–arm or the oil tank's soft pipe of the bucket touch the ground.

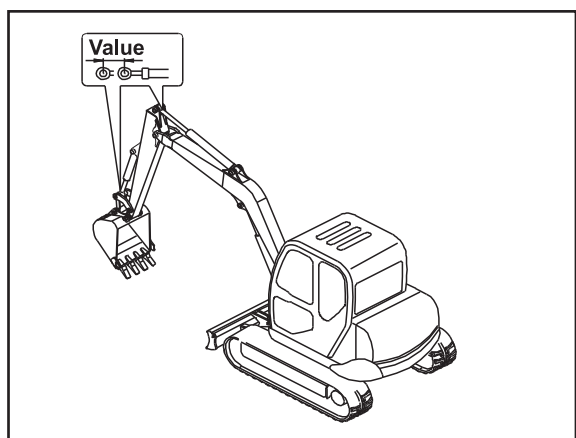
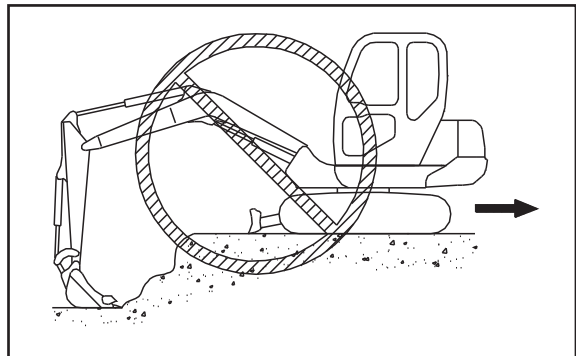
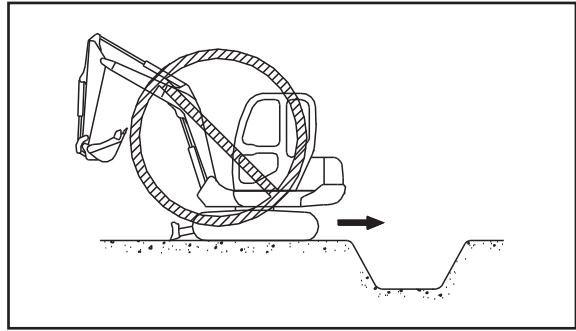

9)When the machine operated,it need to avoid the moving–arm、 the lever、 the bucke、 the cab(lookum) touch the nonego.

10)When the machine rotated,it need to avoid it touch the cover of the engine.

11)When the moving–arm reduced,it doesn't stop unexpected

12)Not dig to the machine body.

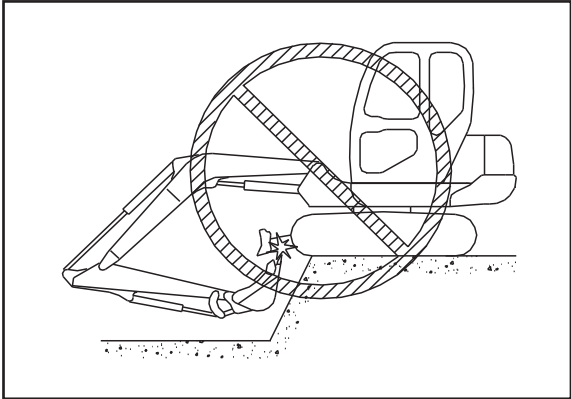

13)When the pedrail leave the ground,it doesn't dig.Otherwise,the machine and the frame will break.

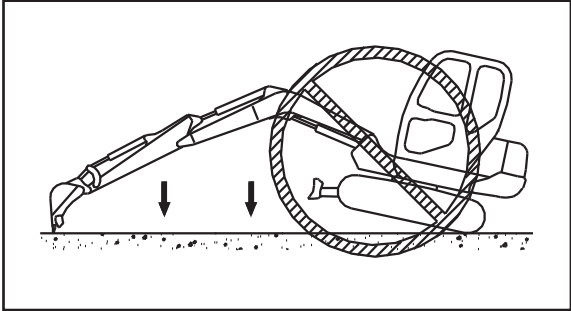

14)Not use the deadweight of the machine to increase the digging power.

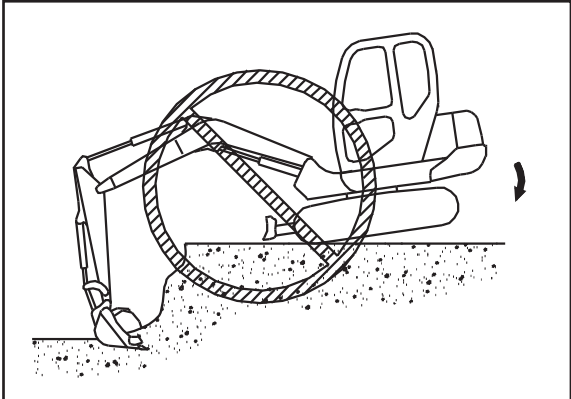

15)Not use the falling power of the bucket regard the handle、 the knapper、 the monkey.It will make the back of the machine bear over weight.

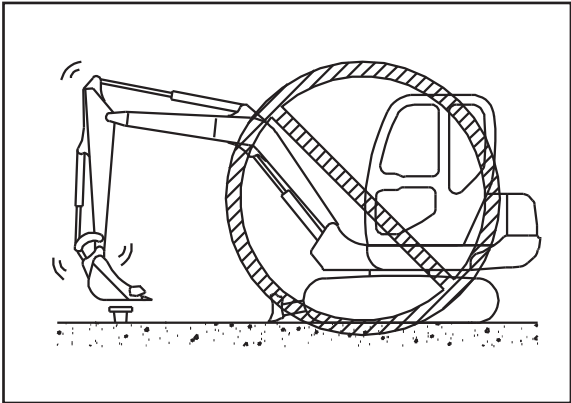

16)Not use the bucket to dig the road surface more. Otherwish, the parts will over load and break.

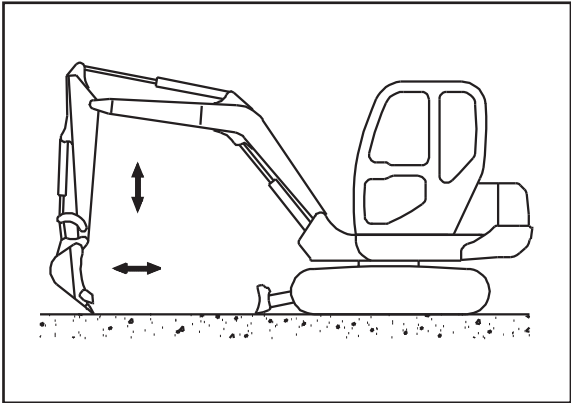

17)Not use the falling power of the machine. Otherwise, the machine broken.

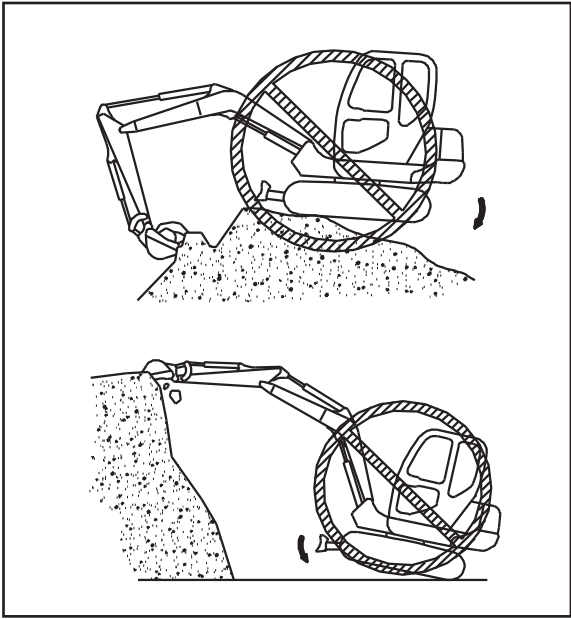

18)Not use the power of rotating to press the soil or destroy the rideau and the wall. When the machine rotates, it doesn't make the gear of the bucket into the soil.

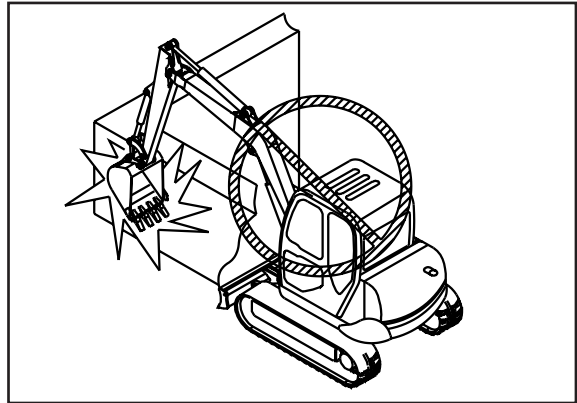

19)Not make the bucket into the soil, and not use the driving power to dig. It makes the back of the machine beat over weight.

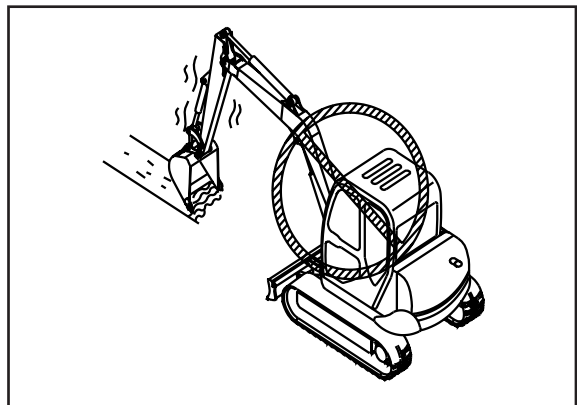

20)Not dig the working plane which under the hanging part. It maybe have the danger of the rockfall or the hanging part collapse.

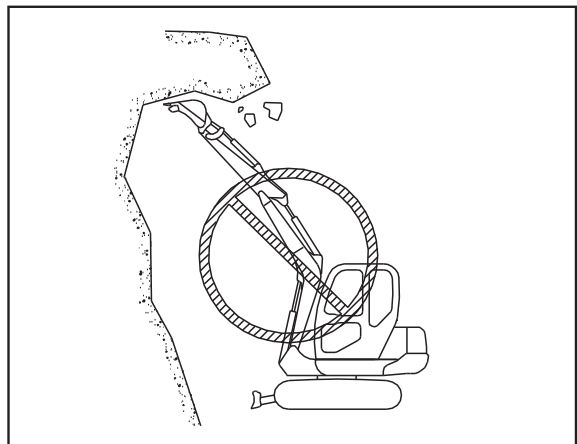

5. Prevent dumpage、ntiskid and the resolvent



Warning:1)If it need to swerve on the slope,it only use the big radian swerve.When the machine turn right,turn the lever of the moving-arm to left.The distance to the ground about 30cm,lock the platform.

2)When the machine slip,it need press the bulldozer and the bucket to the ground.

3)When the machine dumpage,the operator mustn' jump off .It must to fist the handrail or the pillar of the lookum.

Following,the machine is easy to overturn:

1)The machine moves on the uneven road,the two pedrail one side high one side low or half of the pedrail hangs.

2)One of the pedrail touch the soft soil, another touch the hard soil.

3)One side of the machine is Limestone cave or the slime

4)The machine operates on the slope which the portrait gradient more than 25° ,the thing towards the downgrade.

5)The machine operates on the slope which the landscape orientation gradient more than 15° the thing towards the downgrade.

6)On the slope,it is 90° for the two pedrail and the gradient,the rotating platform more than 90°

7)The machine operates on the slope,it swerves,the platform rotates fast or no power.

8)When the machine turn adown about 180° .

9)It is the uneven road for the back operation.

10)The machine dig the underside of the body when it depth digging.

11)The machine moves on the frost road.

12)The two pedrail have the machine oil or the lube

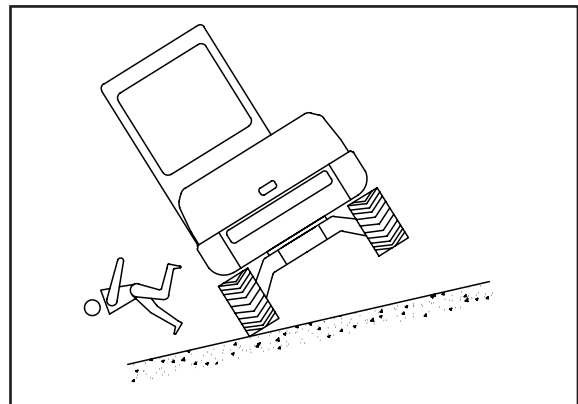

6.Stop the machine

See it at the chapter of parking machine.

Transport & Load and Unload

Transporting (unloading) the excavator must obey the safety rules strictly:

- When the excavator transported, it must obey the safety transport rules of the country (local) trade or the good habit.
- When the excavator transported, the cab can't hitch anybody or anything.
- When the excavator loaded & unloaded, there can't be anything or anybody within the moving radii area of the sling.
- When the excavator loaded & unloaded, there can't be anybody or anything within the traveling area of the loaded & unloaded excavator.
- Except using the sling or drives it from the port, it can use two laths which are strong enough to put in the transporter. The gradient of the laths should be less than 15° , The length of the gradient is 3.5 times of the height. The width of the lath is 1.2-1.5 times of the crawlers.

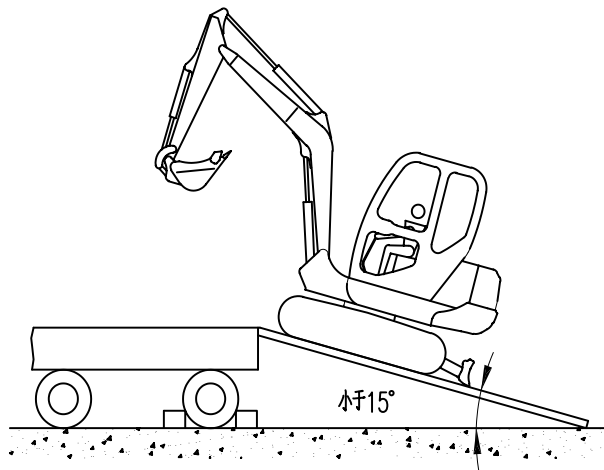

- Do not put down the orientation handle to avoid the platform rotating when it is up or down the slide.
- When the machine drives up or down the slide, do not operate any handle except for the driving handle.
- The machine should be unloaded on the smooth road.
- There should be flags, lights, warning signs when the machine drives on the road. And make sure the other people can see them. Make sure the car after it can see the sign of "Drive slowly".

The machines with crawlers may destroy the road. Please use truck to transport.

Maintain



Warning:When the machine is maintained,it should hang the warning sign"No operation" on the operation handle.

- Machines should stop on the smooth and hard road.
- After the excavator stops, it must put down the bucket, and run the engine 3 minutes with low speed, then stop it and pull out the key.
- Release all the power of the hydraulic system.
- If the machine should stop on the slope, there should be enough road-block under the crawlers.
- There should be enough distance between other machines when the machine stops.
- When the electric system or electric welding is maintained, it should take-down the cathode cable of the accumulator. Do avoid the current movement.
- After the machine starts, do not lubricate or maintain. Do not let the motion touch the running part.
- If the machine needs to maintain when the engine runs, there should be someone to see it.
- Do not put some small parts into the placket.
- The high-pressure liquid can hurt the eyes and the skin. Do avoid it when the machine maintains.
- Do clean all the sundries in the interior of the machine, it may hurt the operator or destroy the machine.
- Do deal with the waste liquid with correct way. Do not throw the oil into ground、 drain、 creek、 pond or lake. Letting oil、 fuel、 antifreeze、 plastic、 accumulator oil and other poisonous waste should obey environmental protection rules.

Fire-proof、Explosion-proof& Antigas

●When the excavator transported, driving, digging, it shouldn't touch the wire. Otherwise, it causes the casualty.

●The wiring and the line needs to check frequently. If it finds the broken, aging part, it must be replaced to avoid the fire.

● Keep the line linker clean and fix it firmly. Check the line everyday.

●Do not put the thing which is flammability or explosive into the excavator.

●Do stop the engine when it oils, and keep away from the fire and do not leave the machine.



●When it is oiling, the fuel can't overflow to the surface which is super heated or the parts of the electric system.

●After oiling, do clean the fuel or machine oil which overflow, and screw down the cover of the fuel or the machine oil.

●Clean out the slip, spill, lamina and other flammability thing which is in the engine*the vent-pipe, the muffler, the engine room.

●Do not put the dishcloth which is with the oil into the cab.

●There should be fire extinguisher in the cab, and put it on the place where can be easily to take from.

●When the machine is welded, do segregate the pipeline of the hydraulic oil and the fuel.

●Do avoid the fire caused by the hydraulic pipeline. Check all the soft pipe and the fastener*the cover*the block whether they fixed firmly.

●Accumulator should be far away from the fire. Do avoid the high temperature. Otherwise it will explode.

●The excavator with cabin should be checked with the sealed center clapboard. Do avoid the exhaust gas into the cab to cause the operator poison.

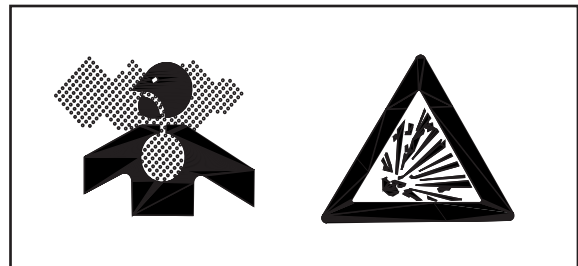

●Do not operate the machine on the area where the airiness system is not good.

●When the fire happens, do not use the water to put out the fire. Should use the powder extinguisher or the sand, or use the slipcover.

Accumulator

Safety rules of the accumulator

The electrolyte of the accumulator includes the vitriol and the hydrogen which is flammability and explosive. The wrong operation leads hurt or fire. Do as follow:

- Check the level of the electrolyte timely. Supply the distilled water to make the level of the electrolyte between the “top level” and the “low level” line. If the electrolyte of the accumulator is lower than the “low level” line, do not use the accumulator.

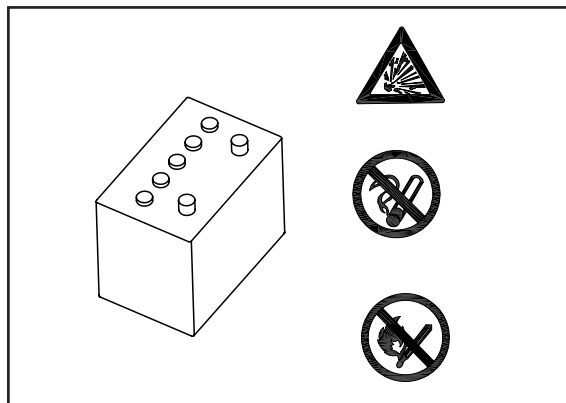

- Do wear the safety glass and the rubber glove when operate the accumulator.
- Do not smoke or fire near the accumulator.
- If the eyes、 cloth、 skin are bespattered by the vitriol, do use lots of water to wash and go to the hospital.
- Before operating the accumulator, it should turn the key to “OFF”.
- Do stop the starting system when use the electric torch to check the electrolyte of the accumulator.
- The end of the sealed accumulator dilates, it show the accumulator freezing. When the accumulator freezing, do not electricize or connect the starting engine. The temperature should be less than 15°C when heat up the freezing accumulator. Otherwise it explodes.

Explosion-proof of the accumulator



Warning:the electric spark or the flame can make the hydrogen of the accumulator explodes.Avoid explode please caution as follow:

- 1)Cut off the cable of the accumulator,it should cut the cathode cable first**
- 2)Connect the cable,it should connect the cathode cable first**
- 3)No use the metal element to connect the port of the accumulatort**
- 4)No welding、grind、smoking near the accumulator**

Because it has danger of spark, do as follow:

- Please fix the accumulator to the right place.
- The tool or other metal can't touch the port of the accumulator. Do not fall the tool or other metal near it
- Connect or cut off the sign of the accumulator follow the right order. The port of the accumulator should fix fast.
- When the accumulator electricized, it produces flammability hydrogen. So before electricized, it should unload the accumulator from the machine, and put it to the draughty place and remove the cover.
- Screw down the cover of the accumulator.

Caution: When maintaining the electric system or weld, it should remove the cathode port to avoid the current flowing.

Hydraulic System

1.Safety rule of high-pressure oil

The inside of the hydraulic system always have the pressure.When it checks or replaces the pipeline or the soft pipe,it must to check whether the pressure has release or not.If it has the pressure,it will make a serious hurt or destroy.Do as follow:

- 1)When the hydraulic system has the pressure,it doesn't check or replace
- 2)If the pipeline of the soft pipe has leak and around the area wet.Please check the pipeline or the soft pipe whether it broken,and the soft pipe whether it dilates. When the operator checks,it should wear the safety glass and the glove
- 3)If the high–pressure touch the eye,it will have the danger of the ablepsia.It need use the clean water to wash the eye or the skin which touch the

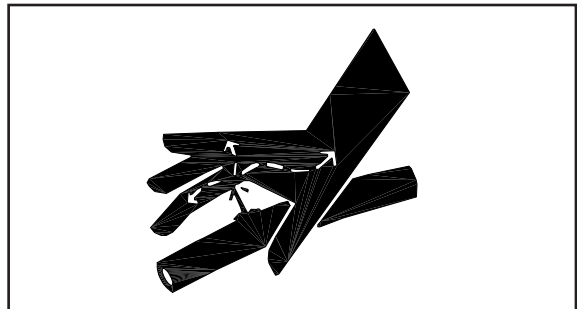
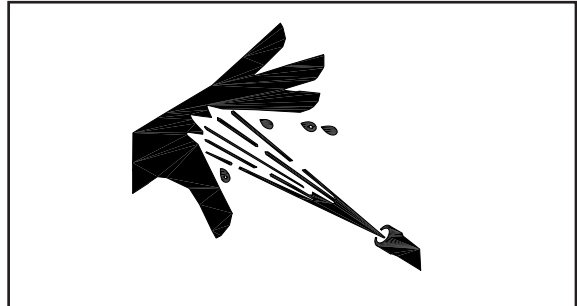

2.Safety operation of the high-pressure soft pipe

If the high–pressure leaks,it will make the fire or the operation trouble. And lead the serious hurt or destroy.If it finds the bolt become less crowded,it should stop the machine,and screw down it.No welding the machine when the hydraulic oil pipeline(soft pipe) not separate.If it finds the soft pipe has any broken,it need to stop operate,and contact us.

If it finds the problems,it need to replace the soft pipe:

- 1)The tie–in of hydraulic pipe has leaked or destroyed
- 2)The envelope broken or cut off,or the steel wire of the reinforcement out
- 3) Some parts of the envelope dilates
- 4)The moving part contorts
- 5)The envelope has the impurity

3.Safety rule of the high-temperature oil

The hydraulic oil doesn't cooling on the working or after working,it is high-temperature and high-pressure.To avoid the oil squirted or touch the hot part make scald when it checks or lets the oil.it should wait the oil cooling and the temperature can touch before do it.It need undo the cover or the bolt slow before unload the cover or the bolt even if the oil cooled.

4.Release the pressure of the hydraulic system

When the digger operates,the hydraulic oil of the hydraulic pipeline in the state of high-temperature and high-pressure.When it take-down the gun,the oil maybe squirts.So it need to turn the cover of the gun before take-down the gun and release the pressure.

1)If the operation device doesn't locate the state as like the picture,it need to start the engine and runs low speed,hold out the oil tank of the bucket.draw back the oil tank of the lever.Then down the bucket, put the bulldozer on the ground,stop the engine.

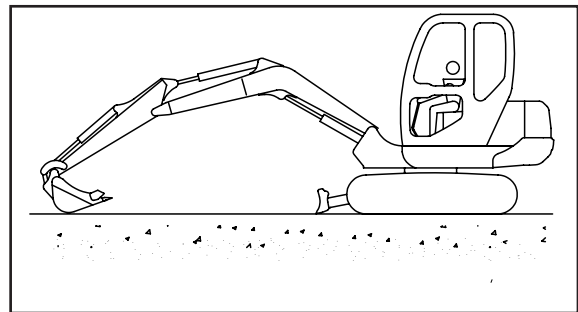

2)Within 15seconds after stop the engine,it turns the switch to “ON” and operates the joy stick to all the direction(operation device、 driving),to release the pressure.

5.Safety operation of the stored energy device



Warning:The stored energy device is the part which full of the high-pressure nitrogen gas.If it's wrong to use,it will explode.No take-down the stored energy device,no drilling and welding.No close the fire,no hit and impact.It deals it ,it would let the professional

The machine have the stored energy device in the control pipeline,It is a device which stores the pressure.When the machine has the device,after stop the engine,it can operates the control pipeline short time.

It operates the joy stick,it can down the operation device by the deadweight.

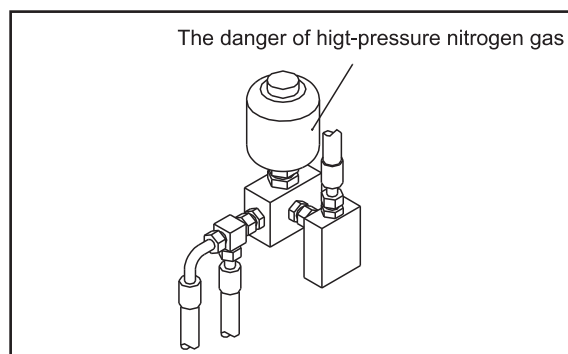

The way of the control pipeline to release the pressure which has the stored energy device:

1) Downing the operation device to the ground, and stop the hydraulic crush or other attachment.

2) Stopping the engine

3) Turning the start key to "ON" to make the current of the circuit moves

4) Turning the safety lock joy stick to the free place, driving the joy stick of the operation device to front、back、left、right and the attachment control pedal, to release the pressure of the control pipeline.

5) Turning the safety lock joy stick to the lock place to lock the job stick and the attachment control pedal.

3

Parts Description

Operating Equipment

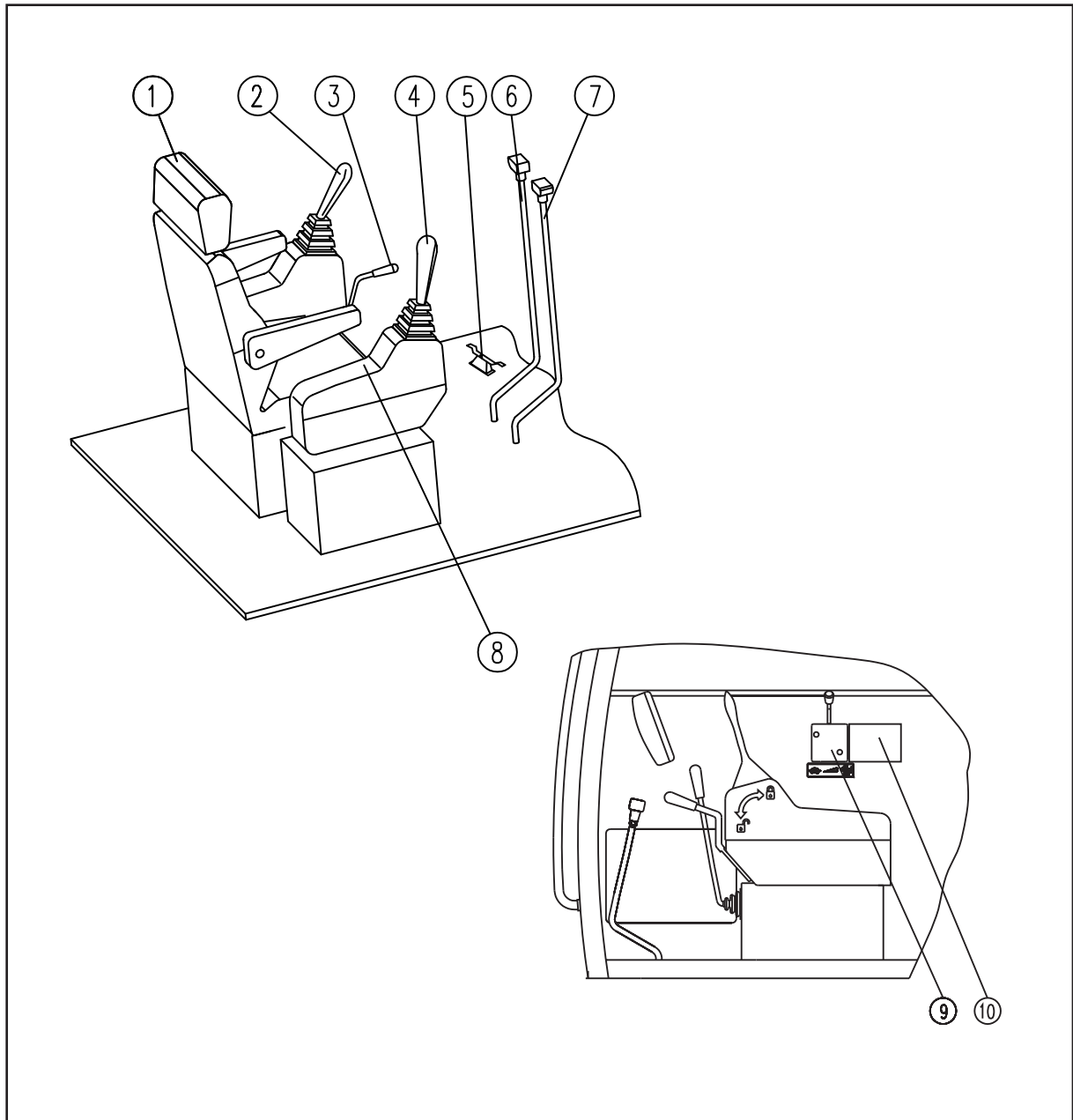

- | | |
|------------------------------|---------------------------------------|
| 1. Operator Seat | 6. Left travel speed level |
| 2. Left operating level | 7. Right travel speed level |
| 3. Blade level | 8. The Panel of right controlling box |
| 4. Right operating level | 9. Throttle level |
| 5. Accessories pedal control | 10. Radio |

Combined Digital Instrument

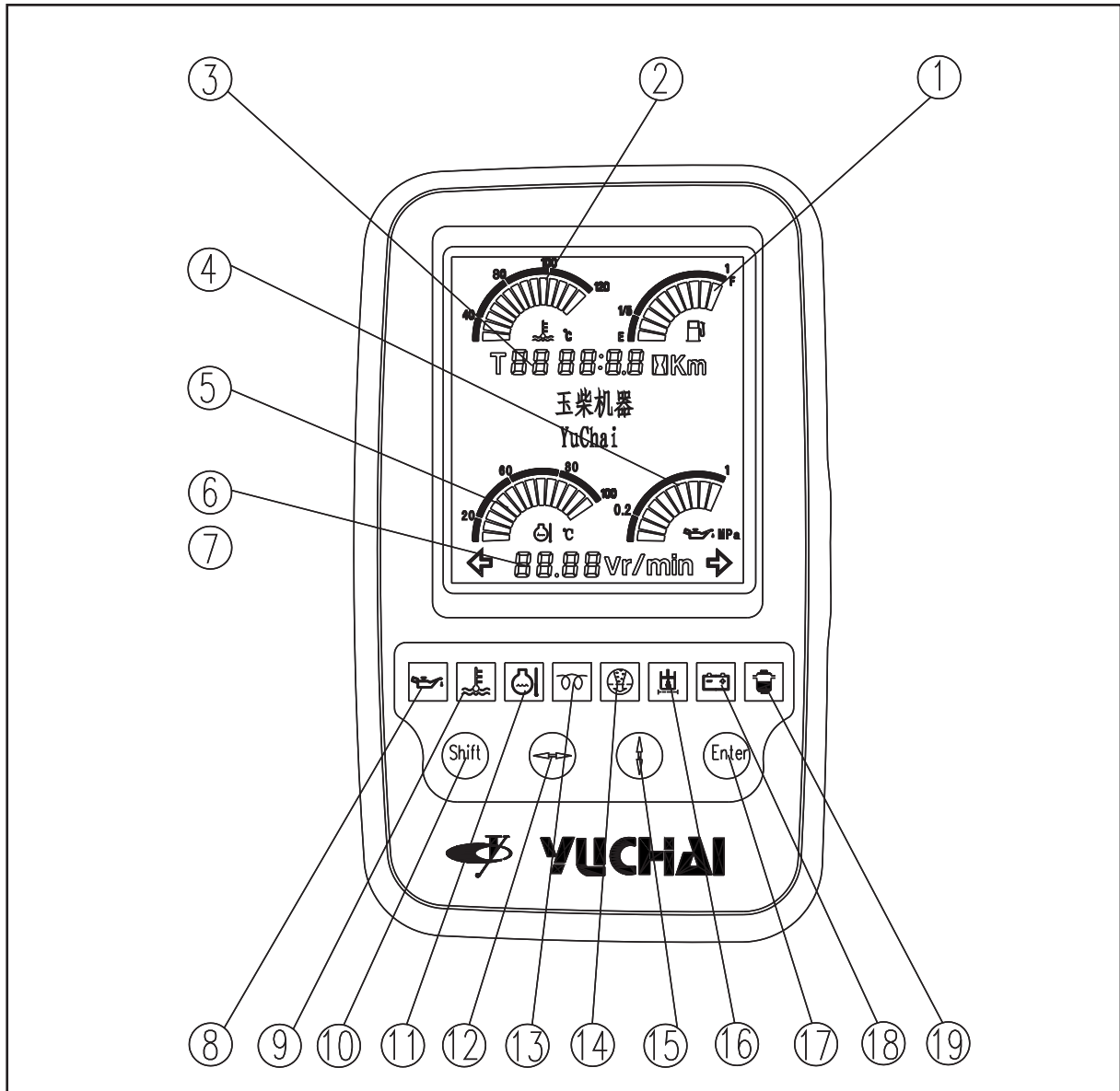

- | | |
|-------------------------------------|---|
| 1. Fuel gauge | 11. Hydraulic oil temperature warning lamp |
| 2. Coolant temperature gauge | 12. Push button clock setup |
| 3. Hour meter | 13. Glow lamp |
| 4. Engine oil pressure gauge | 14. Air filter obstruction warning lamp |
| 5. Hydraulic oil temperature gauge | 15. Push button clock setup |
| 6. Revolution meter | 16. Hydraulic oil filter obstruction warning lamp |
| 7. voltmeter | 17. Push button confirmation |
| 8. Engine oil pressure lamp | 18. Battery charge lamp |
| 9. Coolant temperature warning lamp | 19. Oily water separator |
| 10. Push button indication changer | |

A. Instrument



1. Fuel meter

It indicates the fuel quantity of the fuel tank. When the oil level is under 1/5 of the tank, the sign sparks. When the oil level is under 1/10 of the tank, the sign sparks and the buzzer rings

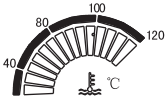

2. Water temperature mete

It indicates the state the water temperature of the engine.



3. Working hour meter

It indicates the accumulative total working time. And it can also indicate the working time of engine when the engine has gone wrong.



4. Oil pressure meter

It indicates the state the machine oil pressure of the engine.

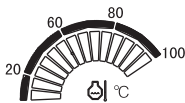

5. Hydraulic oil temperature meter

It indicates the state the oil temperature of the hydraulic oil



6. Rotation speed meter of engine

It indicates the rotational speed and it uses the switch key to replace the mode for indicate the rotational speed meter or voltmeter. And it also indicates the code of the trouble.

7. Voltmeter

It indicates the value of the volt. It can use the switch key to replace the mode for indicate the rotational meter or the voltmeter.

B. Alarming indicate



8. Oil pressure alarm

When the machine oil pressure of the engine under 0.1Mpa, the sign sparks, and the annunciator lights, the buzzer rings.

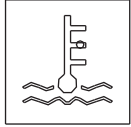

9. Water temperature alarm

When the water temperature higher than the standard value, the sign sparks, and the annunciator lights, the buzzer rings.



11. Hydraulic oil temperature alarm

When the temperature of the hydraulic coil is under 20°C or higher than 80°C but under 90°C, the sign sparks. When the temperature higher than 90°C, the annunciator lights, and the buzzer rings.

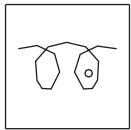

13. Indication in pre-heating status

When the engine warm up, the sign lights.

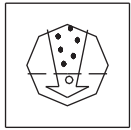

14. Alarm for blocked air filter.

It indicates the filter stopped, when the annunciator lights and the buzzer rings.



16. Alarm for blocked hydraulic oil filter

It indicates the hydraulic oil filter stopped when the annunciator lights and the buzzer rings.

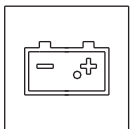

18. Alarm for high/low volt

Confirm the line need 12V or 24V. About the system of 24V, when the engine working, the volt under the alarming value, the electrification trouble annunciator lights. About the system of 12V, when the engine working, the volt under the alarming value, the electrification trouble annunciator lights.



19. Alarm for the separation of oil & water

When the water storage in the separator has reached to an extent, this sign lights.

C.The operation of functional buttons



10. Shift key

It uses to switch the clock or hour meter indicates

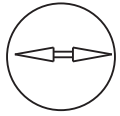

12. Left & right key

It uses the hour meter to indicate the code trouble,it indicates +key. Press the +,it will circle between 0X-----5X.When it indicates the clock state,it can replace the hour or minute.

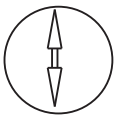

15. Top & bottom key

It uses the hour meter to indicate the code trouble,it indicates - key.Press the -,it will circle between 0-----9.When it indicates the clock state,it can replace the min.valuve(0023) or the minute state replace the minute(0059)



17. Enter key

After replace the time,press the key two,the replace time entered.

Note: "Enter"

D.Failure code list

When the machine has problem, you can know the case as the instruction sheet shows.

The bottom of the screen indicates the trouble code Er00-----Er59

The top of the screen indicates the working hour of the engine when the machine has problem.

Meaning of code:

Er00----Er09,it indicates the time when the hydraulic oil has trouble.The total is ten points.The instruction sheet can store 10 points of the latest.

Er10----Er19, it indicates the time when the volt over high .The total is ten points.The instruction sheet can store 10 points of the latest

Er20----Er29, it indicates the time when the water temperature has trouble.The total is ten points.The instruction sheet can store 10 points of the latest

Er30----Er39, it indicates the time when the oil temperature has trouble.The total is ten points.The instruction sheet can store 10 points of the latest

Er40----Er49, it indicates the time when then oil filter has trouble.The total is ten points.The instruction sheet can store 10 points of the latest

Er50----Er59, it indicates the time when the air filter has trouble.The total is ten points.The instruction sheet can store 10 points of the latest

Switch group on Right Controlling Box

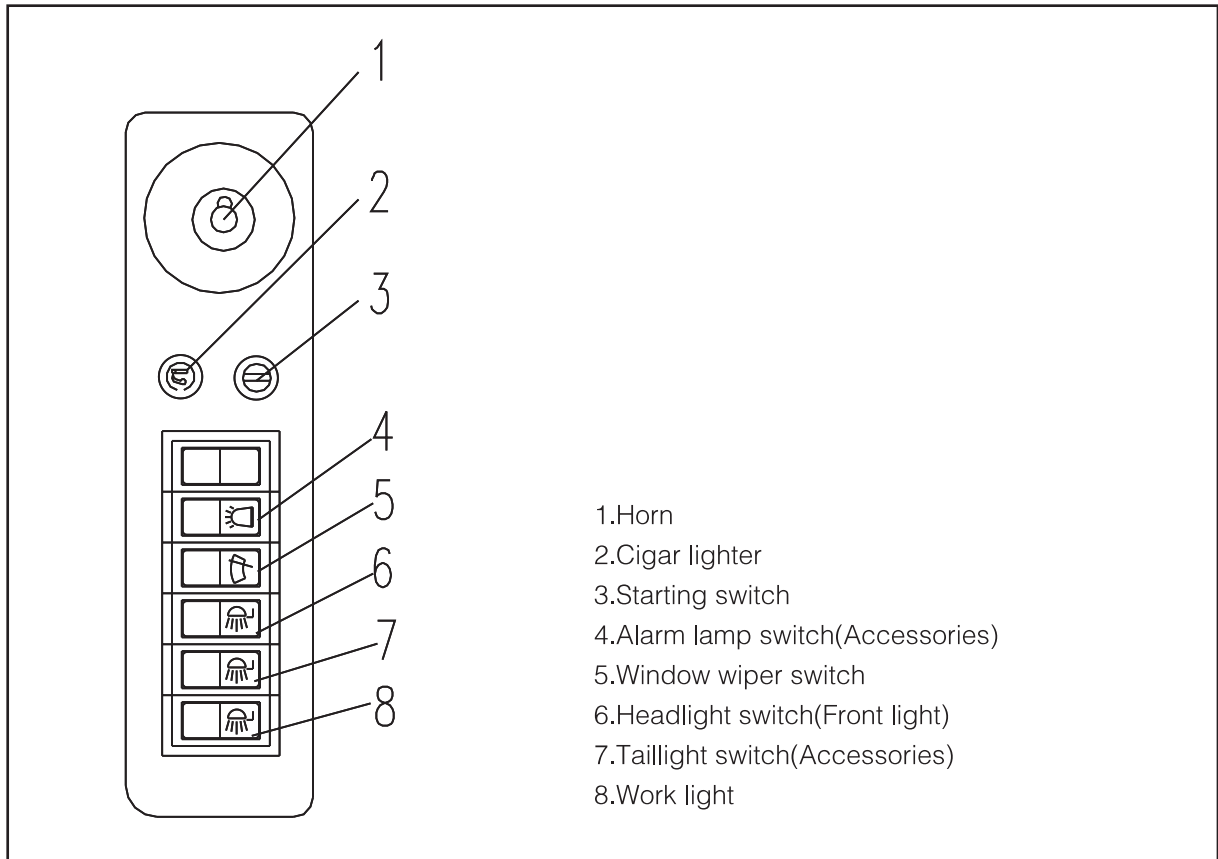

1.Horn

The horn will sound while you push it.



2.Cigar lighter

Directly connect the Cigar lighter, or use the cable of cigar lighter to supply the power for the other electrical equipment.

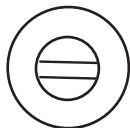

3.Starting switch

OFF Position:

In this set the machine is totally OFF, so you can remove the key from the socket.

ON Position:

After starting, the key came back in ON Position; Meanwhile the engine is running, leave the key in ON Position.

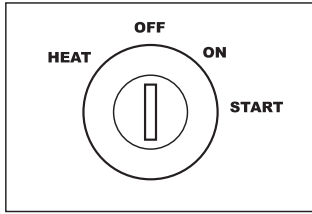

Start Position:

To start the engine move the key in Start Position. While starting the engine keep the key in this position, when the engine run suddenly release the key, which came back in On Position.

Preheating Position (HEAT):

Before started the engine, specially in winter, put the key in "HEAT" Position, so the preheating lamp (13) will flash. Leave the key in this position until the lamp turn off, then start the engine.



4. Alarm lamp switch (Accessories)

The switch of Alarm lamp on the roof.



5. Window wiper switch

When the key is in ON position, this switch control the window wiper on the front cabin's window.(It is not present for canopy setting).

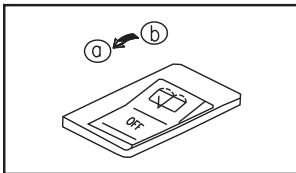

Notice: Do not turn On the window wiper when the window is dry, otherwise the rubber will be damaged.



6. Headlight switch (Front light)

When the start key is in ON position, each switch will control the arm and roof light ON/OFF.



7. Taillight switch (Accessories)

When the start key is in ON position, each switch will control the Taillight on the roof ON/OFF.

8. Work light

Notice: Do not turn on all of lights together.

Panel Switch of Left Controlling Box

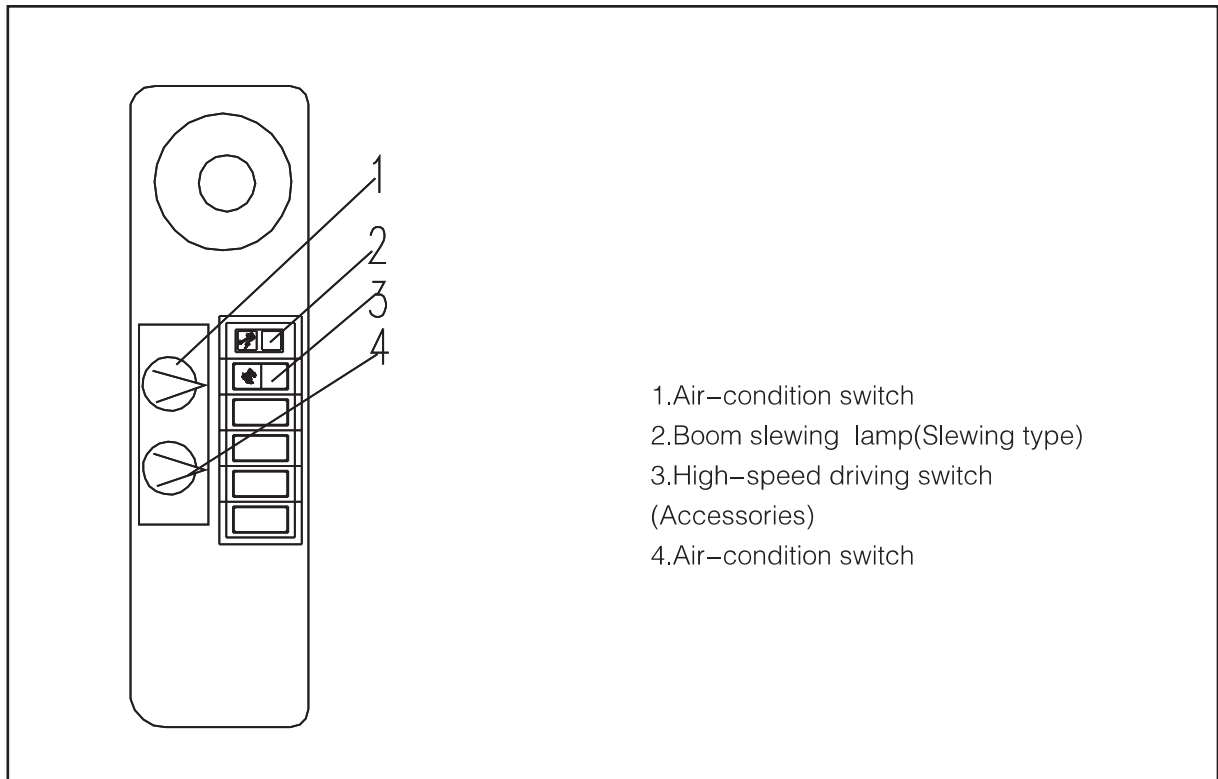

1. Air-conditioning Switch

2. Boom slewing lamp (Slewing type)

It will alight when the machine in the mode of boom slewing. It will off when the machine in the mode of platform slewing.

3. High-speed traveling switch (Accessories)

To select the speed of traveling , high or low.

Safety Lock Part

1.Safety lock



Warning:The safety lock part is the important part of the safety system.When the operator leave the cab,it must safety lock.If the safety lock handle doesn't stay the lock stations,the handle maybe moves and make the operation device or the platform move.

Put the safety lever lock in lock position and the working equipment and platform do not work (except left/right travel, dozer blade) to safeguard.

Put the safety lever lock in unlock position and the working equipment and platform work properly.

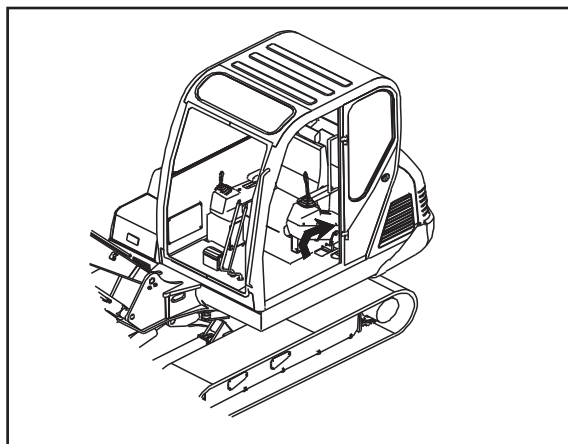

Work Equipment and Swinging Control

1. Digging and Platform swing Control (The Type Without Boom Slewing)

Control by right/left lever, as show in right figure

Left pilot-controlling valve Right pilot
–controlling valve

A. Left lever

Digging arm movement: Push forward and the arm out; Push backward and the arm in.

Platform Swinging movement: Push right and the platform right rotation; Push left and the platform left rotation.

B. Right lever

Arm movement: Push forward and the boom lower; Push backward and the boom raise
Bucket movement: Push right and the bucket dump; Push left and the bucket load.

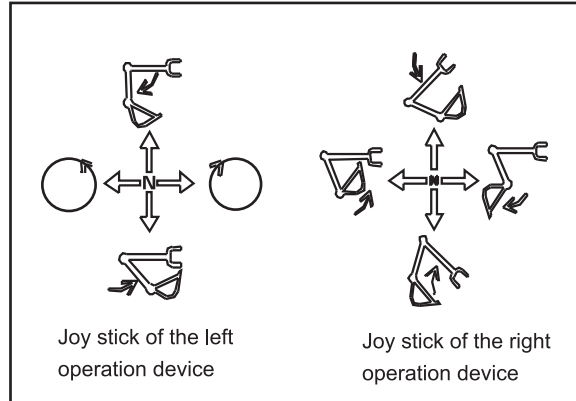

2. Digging and Platform swing Control (The Type With Boom Slewing)

A. Left lever

Left pilot-controlling valve Right pilot
–controlling valve

Digging arm movement: Push forward and the arm out; Push backward and the arm in.

Platform Swinging movement: Push right and the platform right rotation; Push left and the platform left rotation.

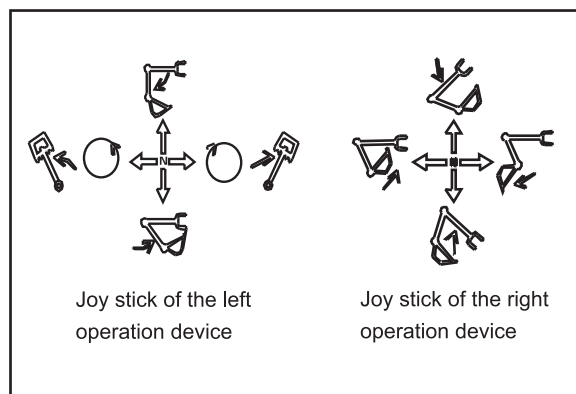

Boom Slewing movement: Push right and the boom right slewing; Push left and the boom right slewing

B. Right lever

Arm movement: Push forward and the boom lower; Push backward and the boom raise

Bucket movement: Push right and the bucket dump; Push left and the bucket load

● **Boom Slewing Selector**

After you have pushed the button on the left pilot valve handle, you can control the boom slewing or the platform swinging. Direct control the left lever to swing the Cab/Canopy under normally condition.

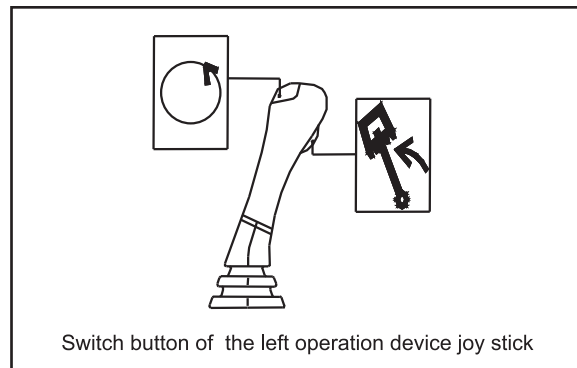

3. Operate the bulldozer

Push-down the joy stick, the bulldozer into the soil. Pull-up it, the bulldozer lift.

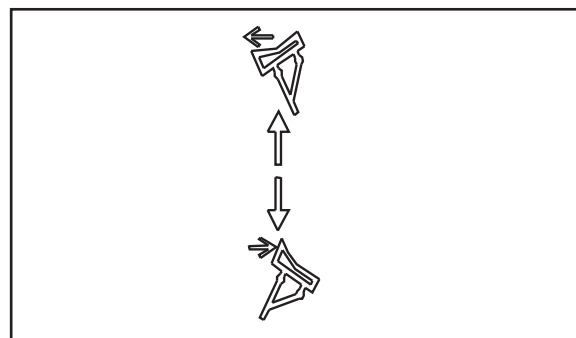

4. Operating the assistant operation device

When the machine has the assistant operation device, it opens the shift fore, pedal cover of the assistant operation lead valve, and step the pedal of the lead valve, it can connect the assistant oil.

Driving Operation

1. Control the direction

Operate the left、right driving joy stick to control the pedrail of the machine.

Operating one side of the joy stick,it can make machine to turn one side.

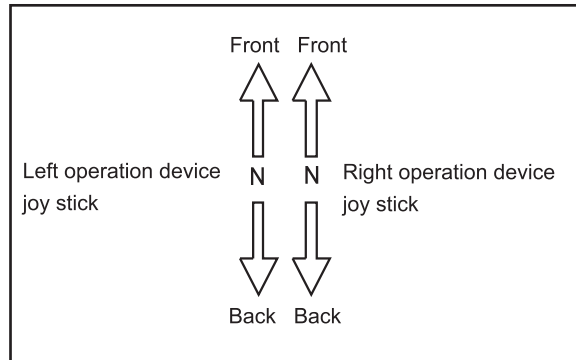

2. Control the speed

1)To the standard configuration:it use the assistant operate lead valve to control the speed. It opens pedal cover of the assistant operation lead valve,and step the pedal of the lead valve to make the machine driving high-speed.

2)To the electric and aptitude control:it use the high\low control button of the left operation box to control the driving speed.

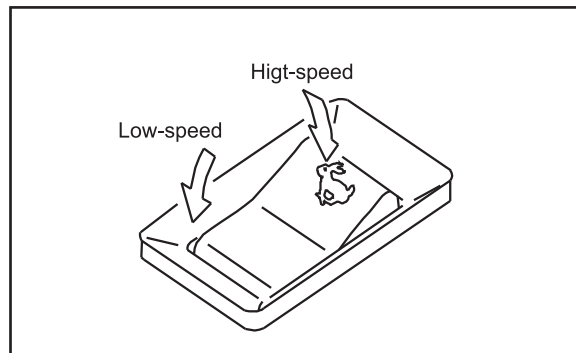

Throttle Lever

● Throttle Lever

- 1) Accelerate: Push backward the lever;
- 2) Push forward the lever before the engine stop and push back the lever after the engine stop.

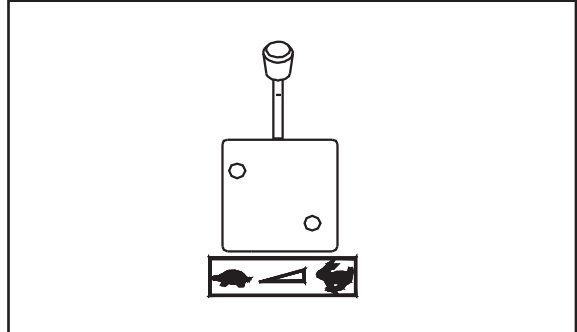

Operator Seat



Warning:If the machine to turn over or move suddenness,it will lead hurt.Rememeber ot tie the safety belt and adjust the seat before start the machine.

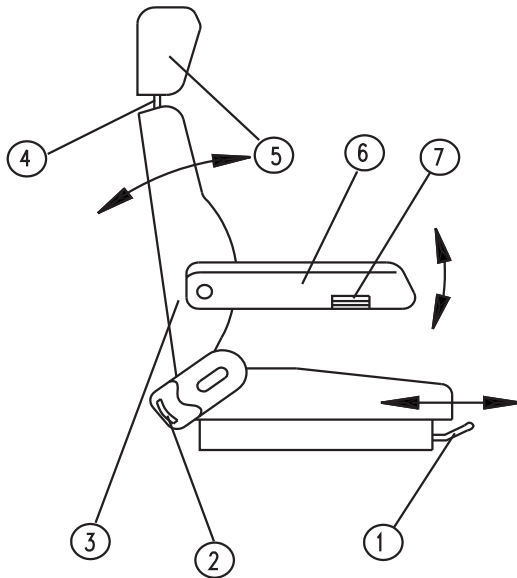

- 1.Front&back adjusting handle of the seat
- 2.Adjusting handle of the backrest
- 3.Backrest
- 4.Adjusting handle of the pillow
- 5.Pillow
- 6.Handrail
- 7.Stope adjusting handle of the handrail

- Front&back adjusting the seat:twist the front&back adjusting handle of the seat, it allows to move about 0-75mm.Loosen the handle, the seat locked.
- Adjusting the backrest:pull-up the adjusting handle of the backrest,the backrest can adjust about 5 grade,loosen the habdle,the backrest lock perchs.
- Adjusting the pillow:Moving the adjusting handle of the pillow back,and push&pull the pillow to the right place.
- Adjusting the slope of the handrail:turn the slope adjusting handle of the handrail,it adjusts the slope.

Caution:When it need to adjust the seat, it stops the machine. After adjusting, jiggle the seat to make sure the seat locked.

Safety Belt



Warning:The safety belt is the important part of the safety system.Before the operation,it must tie the safety belt.If the operator doesn't tie it,it will hurt him when the machine to turn over.



Warning:Before tie the safety belt, it need to check whether the safety belt unconventionality.If it fray or destroy,it need to replace it.

- If the safety belt doesn't have any unconventionality,it need replace the belt every three year.The product date indicates in the leave factory label
- Operating the machine,it must tie the safety belt.
- When the operator tie the safety belt,it doesn't make the belt twist.

1.Fix the safety belt

Holds the safety belt and checks the belt whether twists.Adjusts the length of the belt.Then puts it into the button.And pulls the belt lightly.Last checks the safety belt whether locked right.

2.Ravel the safety belt

Press the red button,it can ravel the safety belt.

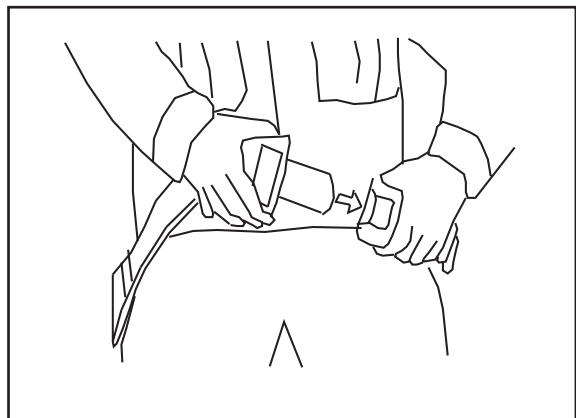

Air-condition Control

The plane of the air-condition lies on the plane switch ground of the left joy stick.

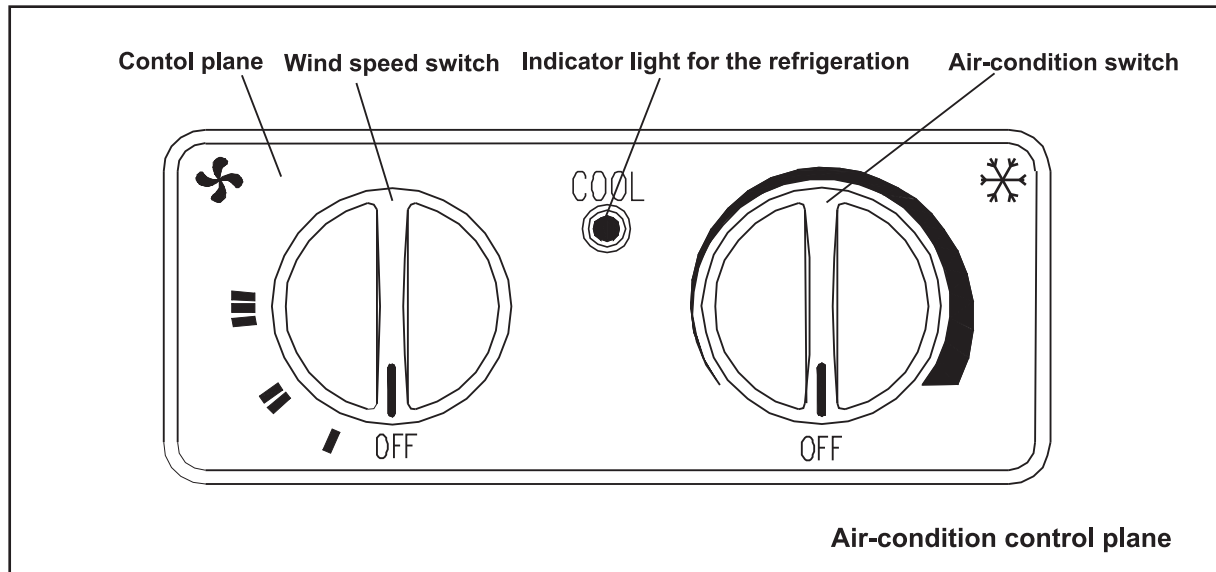

1.Basic operation of the aeration

- 1) Turn the air-condition switch to "OFF" anticlockwise;
- 2) Turn the wind speed switch to I、 II、 III deasil as need.
- 3) See the picture a、 b,turn the wind direction t the right place.
- 4) Turn the air-condition switch to "OFF" anticlockwise,it stop the air-condition.

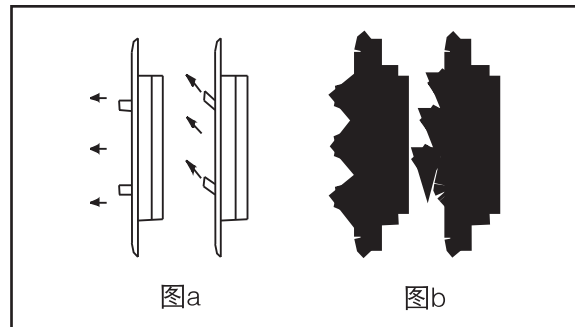

2.Basic operation of the refrigeration

- 1)Press "Basic operation of the refrigeration" to replace the wind speed and wind direction.
- 2)Turn the air-condition switch to the right place
- 3)Adjust the wind speed、 wind direction、 cooling to make a comfortable condition.
- 4)Turn the air-condition switch to "OFF" anticlockwise,and Turn the wind speed switch to "OFF " anticlockwise,it stop the refrigeration.

3.Basic operation of the warming

Press" basic operation of the warming,when the warm water valve.

Radio

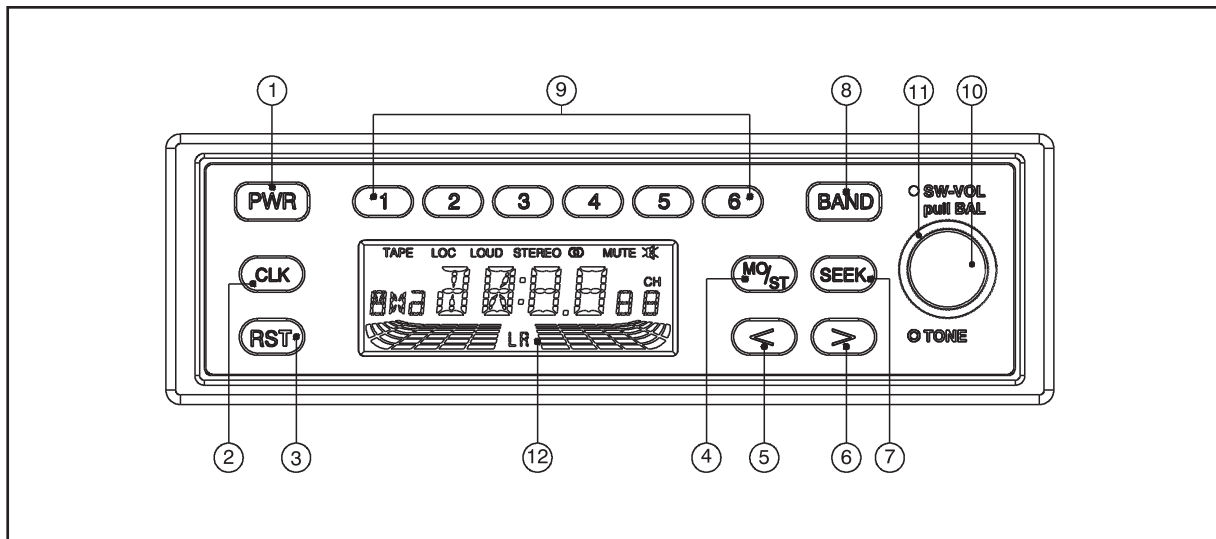

- | | |
|--|-----------------------------------|
| 1.Electrical source key | 7.Automatic channel selection key |
| 2.Time/ frequency switcher | 8.wave band switcher |
| 3.Replace key | 9.Channe preset keyl |
| 4.Stereo/mono mix switcher | 10. Volume/balance adjuster |
| 5.Manual downwards channel selection/time adjuster | 11.Volume adjuster |
| 6.Manual upwards channel selection/time adjuster | 12.Display |

Operation Manual of The Radio

1.Start & Stop

Press 1.PWP key,the electrical source open,the radio starts.Press it again,the electrical source close,the radio stops.(If the radio is the automatic electrical source,press any key to start the radio,press 1.PWP key stop it.)

2.Switch the wave band

Press 8.BAND key to switch the wave band,the order of the wave band:FM1–FM2–FM3–AM1–AM2

3.Channel selection by automatic

Press 7.SEEK key one time,the radio will select channel from low to high by itself.When it select the channel,it will lock and play.

4.Channel selection by manual

When the radio' s signal weak,it adopts channel selection by manual.Press5.<key or 6.>key to downwards or upwards channel selection.Press5.<key or 6.>key long time,it can downwards or upwards channel selection fast.

5.Memory channel by manual

When it selects the channel by automatic or by manual,press the preset key of memory channel long time (more than 3 seconds).

6.Stereo/mono mix switcher

Press 4.MO/ST to switch the stereo mix and mono mix.When the display "STEREO" lights,it is the stereo mix mode.If the display "∞" lights,it means the stereo channel.If the signal of the stereo mix weak,please switch to the mono mix mode to improve the effect.

7.Time/ frequency switcher

Press 3.CLK key to switch the time/frequency mode..When it is the time mode,press other key(except PWR key),it will return the frequency mode.It will return the time mode by automatic after 5 seconds

8.Time adjusting

Press 2.CL key long time(more than 3seconds),the time sparks.It mean it enter the time adjusting mode.Now press 5.<key to adjust the minute,press 6.>key to adjust the time.After adjusting,it will return the natural display mode in 5seconds.

9.Volume adjusting

Turn 10.to adjust the volume.

10.Tonality adjusting

Turn 11.to adjust the tonality.

11.Left&right balance adjusting

12.System replace

If the radio doesn't work good,please press 3.RST,it will renew the status when it produced.

Note1:The digger doesn't have the time function of the radio.

Note2:Because of the different radio,it has the different operation plane.

Door and Window

1. Door of the cab

It is the only way to enter the digger for the operator. When the operator leaves the cab, he needs to lock the door.

When open the door, it should the lock belcoks to the lockpin. When it needs to close the door, it shoild press the door pull rod. The lockpin open, and the door open.

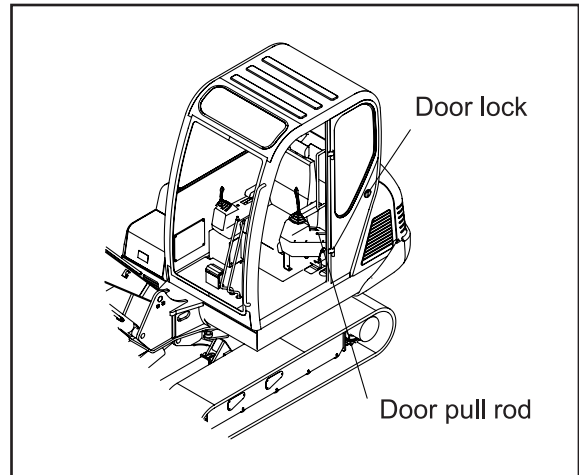

2. Rear window

The rear window can as a exit. When the door couldn't open, and the operator couldn't out and need get away from the cab, it can use the flee hammer to smash the rear window.

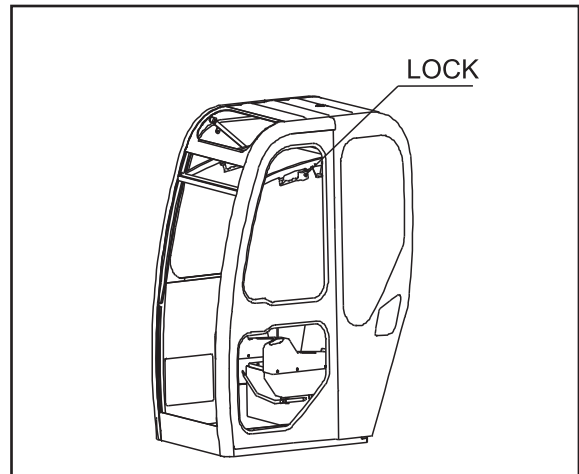

3. Fore window (Turnover window)

If it opens the turnover window, the operator can have a good condition.

If it wants to open the turnover window (fore window), it needs to pull the two commode handles of the turnover window. Operating the commode handles to glide the turnover window. When the turnover window glide to the right place, and push-up the turnover window to the lock place, loosen the commode handle lock, the turnover window locked. Whereas, the turnover lets down.

4

Operation Manual

Preparation for Running Machine

- 1)The digger is operated by the qualified driver.
- 2)Don't operate the machine before the operator read the user manual.
- 3)The operator need to put on the interrelated safeguard: sheathy work clothes、 motorcycle safety helmet、 work shoe and so on(safety glass、 safety earplug、 glove、 safe belt)
- 4)It needs to check the machine before running the machine every day.
- 5)Check whether the operation device、 the oil tank、 the rubber pipe destroy.
- 6)Clear the dust which around the engine、 the radiator、 the accumulator.
- 7)Check whether the hydraulic device、 the oil tank、 the rubble pipe、 the tie-in leak.
- 8)Check whether the infrastructure destroys ,whether the bolt loosens,Whether the bolt loosens which connect the frame and the platform.
- 9)Check whether the instrument destroys.
- 10)Clean the reaview mirror,check whetherdestroies and adjust the angle.
- 11)Check whether the safety belt destroys.
- 12)Make sure to do the maintenance with the right way.



Caution: Before operating the machine, make sure that you have read the safety concept and understand it well.

Engine Operation



Warning: Before start the engine, please reading the safety detail of the user manual. Reading the safety sign of the machine.

1. Check the machine before start the engine

- 1) Check whether ties the safety belt, rings the trumpet, make sure nobody on the workplace and the top/bottom of the machine.
- 2) Check whether the reaview mirror and the widow can supply good view.
- 3) Clear the dust which around the engine、 the radiator、 the accumulator
- 4) Check whether the operation device、 the oil tank、 the rubber pipe destroy
- 5) Check whether the hydraulic device、 the hydrualic oil tank、 the rubble pipe、 the tie-in leak
- 6) Check whether the infrastructure destroies , whether the bolt loosens or whether leaks.
- 7) Check whether the instrument destroies
- 8) Check whether the oil level of the hydraulic oil、 the fuel、 the electrolyte of the accumulator、 the machine oil of the engine between the upper limit and the lower limit.
- 9) In the cold day, it need to check whether the hydraulic oil、 the fuel、 the electrolyte of the accumulator、 the machine oil、 the lube freeze. If they freeze, it should start the engine after thaw.
- 10) Check whether the left joy stick on the lock state.
- 11) Check what the state、 the direction、 the station of the machine.

2. Start the engine



Warning: When the joy stick hangs the safety sign "No start engine", it doesn't allow to start the engine.



Warning: Before start the engine, it must to make sure the safety lock handle on the lock state.



Warning:In the cold day to start the engine,it need to warm-up.If it doesn't warm-up,the joy stick will slowness,and may be lead the accident.



Warning:If the electrolyte of the accumulator thaw,it doesn't electricize or use the different power to start the engine.Where as ,it will fire. Before the electrification or use the different power to start the engine,it makes the electrolyte of the accumulator unfreeze.

Before start the engine,it should the key insert the start switch.,and turn to “ON” ,check the display state of the indicate alarming light of the digital combination instruction sheet.If it has the alarming,it need to deal the trouble and then start the engine.

A.Normal temperature to start the engine

When the temperature of the condition exceeds 5 degree,turn the key to “ON” ,the indicator light wink,and it mean the machine can start.Then turn to “START” ,it keep the key on the place not exceed 10seconds.After starting the engine and loose the key,it will return to “ON” by itself.If it finds the engine not start,it should start the engine again after 30 seconds.

B.Cold temperature to start the engine

When the temperature of the condition under 5 degree, turn the key to “HEAT” to warm-up. About 6 seconds after warm-up finish, the warm-up indicator light wink. Then turn to “START” , and start the engine

Caution: the time of the warm-up not exceed 30 seconds.

Caution: continuous start it not exceed 10second;The time for start it again not under 1 minute.If it doesn't start the engine three time,it needs to check whether the system ok.

Warning:



- 1)When the engine runs,it hadn't to turn the key.
- 2)When it drags the digger,it haven't to start the engine.
- 3)Haven't to use the way to start the engine which start the motor short circuit

C.Use the assistant cable to start the engine



Warning:When the electrolyte of the battery freezes,if (1) it electricizes or(2) use the different power to start the engine,the battery will explode.To avoid the electrolyte of the battery or freeze,it keeps it have full electricity.



Warning:The battery can produce the explode air.It must keep away from the fire、 the spark.Electricize it in thesealing area or it keeps ventilated area when use the battery.Working need the battery,it need wear the eyepatch.

If the way for connect the assistant cable wrong,it will lead explode.It must do as follow:

1)When it uses the assistant cable to start,it need two persons to operate(one sit on the operator'seat,another operates the accumulator)

2)When it uses another machine to start,it haven't to the two machine touch.

3)When it connect the assistant cable,it need to turn the keys of the normal machine and the trouble machine to "OFF"

Whereas,when it has the power,the machine will move.

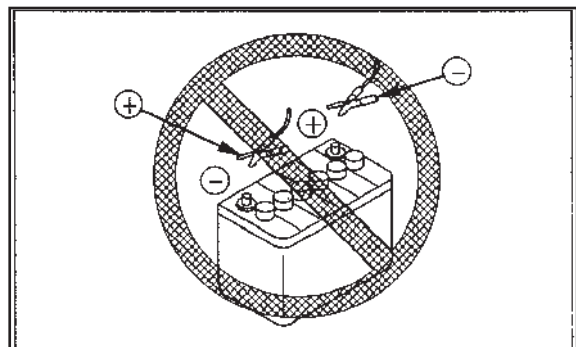

4)When it installs the assistant cable,it must connect the cathode(-) of the accumulator at last;When it removes the cable,it must off the cathode(-) of the accumulator first.

5)When it removes the assistant cable,it doesn't let the nip of the assistant cable touch one another or the nip of the cable touch the machine.

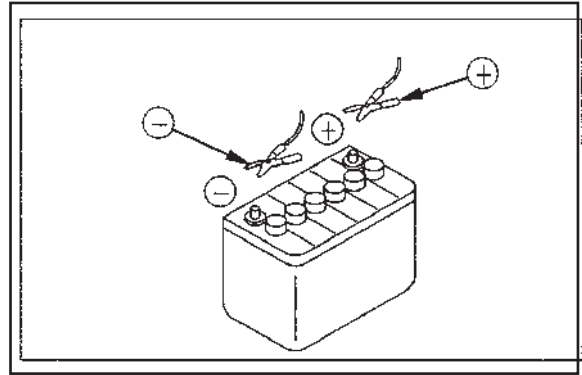

6)When it uses the assistant cable to start the engine,it must to wear the eyepatch and the rubber glove.

7)When the use the assistant cable to connect the normal machine and the trouble machine ,it needs to use the normal machine which has the same volt with the trouble machine.

3.After start the engine

A.Warning the engine and warn-up the machine

The normal temperature of the hydraulic oil is 50°C–80°C.If it operates the hydraulic oil under 20°C,it will destroy the hydraulic element.So before start to working, if the temperature under 20°C., it must warn–up as follow:

- 1)The engine runs 5 min with the speed exceed 200rpm
- 2)Put the gun of the engine to the median to run 5–10 min
- 3)Under the speed,flex each oil tank ,operate the rotating device and the driving motor to warn–up.When the oil temperature arrive 20°C,it can run.If it needs,it can flex the oil tank of the bucket to the travel end–point,warn–up the hydraulic oil.But the time for it not exceed 30seconds.It can repeat till arrive the request of the oil temperature.

B.Examining after start the engine

- 1)Check whether the indicator light wink.
- 2)Check whether leak oil(the lube、 the fuel) and leak water
- 3)Check whether the sound、 the libration、 the calefaction、 the smell、 the instrument have the unconventionality.

4.Stop the engine

Caution: If you shut down the engine before it cooling, it will shorten the use life. Except urgent, no stop the engine suddenly.

If the engine superheat, don't stop the engine, it need cooling the engine with the mid-speed running, then stop the engine.

- 1)Push the gun goes ahead to the end.
- 2)Make it cooling with the low-speed running about 5min.
- 3)Turn the key switch to “OFF” , stop the engine, and the indicator lights wink.
- 4)Take the key.

5.Examining after stop the engine.

- 1)Check whether the machine leaks oil or water.
- 2)Add the oil to the fuel tank
- 3)Check whether the engine cab has the wastepaper or the scrap. Clean the wastepaper and the scrap to avoid the fire.
- 4)Clear the soil of the underpan.

In&Out Machine

- 1) Make sure to grasp the handrail of the cab's door (see the arrowhead of the picture)
- 2) Make sure the feet step on the pedal placidly.
- 3) In&out the machine, it hasn't to use the joy stick instead of the handrail
- 4) Before in&out the machine, it makes sure whether the handrail、 the pedrail have the soil、 the oil. If they have, please clean them.
- 5) No jump up or down the machine, when the machine moves ,it doesn't allow to jump up or down the machine.
- 6) Before leave the machine, it must let the operation device down and use the safety lock handle to pull-up the control box, make the machine in the lock state, and stop the engine, and keep the state to the next operation.

Caution: When the operator leaves the cab, please take out the key and lock the door and the window.

No allow climb up the oil tank、 the cover of the engine、 the top of the cab.

Under any state, the operation devices (the bucket、 the lever、 the moving-arm、 the attachment) don't allow have the person.

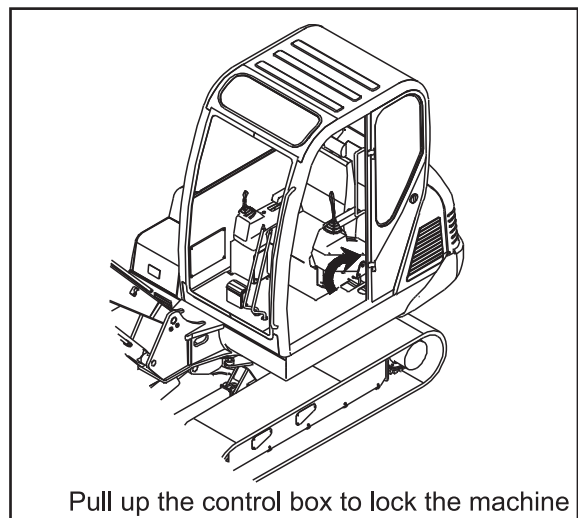
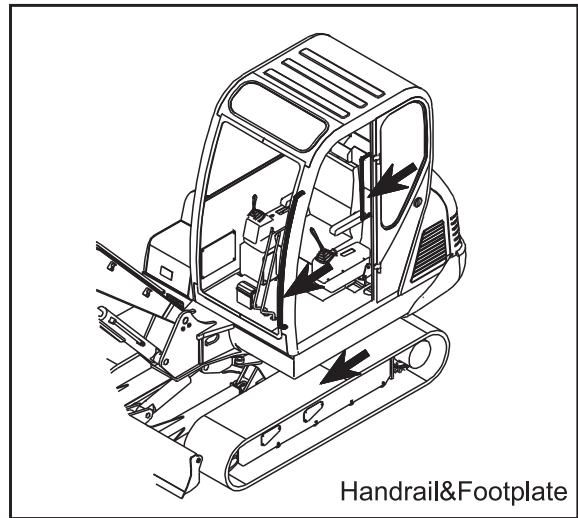

Moving of The Machine

1.Safety rules for moving the machine

- 1)Before start the digger,it need know the condition,know whether it has the passerby or the roadblock and know the bearing power of the ground.
- 2)Before start the digger,it need to ring the alarming to caution the passerby.
- 3)No start or operate the machine when the operator on the ground.
- 4)The digger must drive、 operate on the hard ground which the width must more than 1.5 times
- 5). When the machine drives on the area which have the underpass、 the bridge、 the cable,it need have the sign command.
- 6)When the machine drives,it must down the moving–arm、 the lever,and keep the best station of the barycenter.
- 7)When the machine drives,it only allow the operator in,not hitchhiking other persons.
- 8)When the machine drives on the smooth road long time,it can't lock the platform.But it up&dow slope,it has to lock the platform.
- 9)Before turn the joy stick,it should check the direction of the pedrail frame.
- 10)Don't allow the person in the area which the machine around
- 11)Clear the roadblock when the machine drives.
- 12)It is a blind spot which behind the machine,when it is back a car,and need caution.



Warning:When it is high-speed driving,it is dangerous to turn the joy stick suddenly.

- 1)No turn the joy stick suddenly,otherwise,it will make the machine starts suddenly.**
- 2)Avoid to replace the joy stick from go ahead to back off suddenly(or from back off to go ahead)**
- 3)Avoid the joy stick replaces suddenly,for example from the high-speed and stop suddenly(loosen the joy stick)**

2.Prepare for moving the machine

Put down the lock pin of the platform;
lock the rotating of the platform.

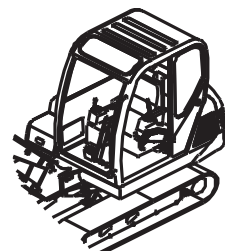

2) Make the gun handle run to the hi-speed, to increase the rotate speed.

3. Moving the machine forward

1) Adjust the safety lock handle and the control box to the free station, lift the operation device and off the ground 40cm to 50cm

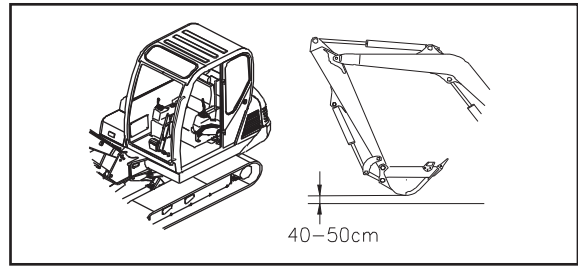

2) Operate the left&right driving joy stick as follow:

When the bulldozer in front, push the foreside of the joy stick forward slowly, and make the machine moves.

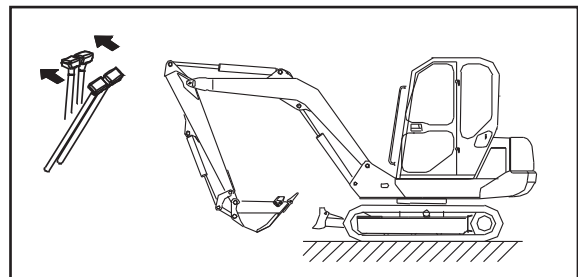

When the bulldozer in back, pull the joy stick backward slowly, and make the machine moves.

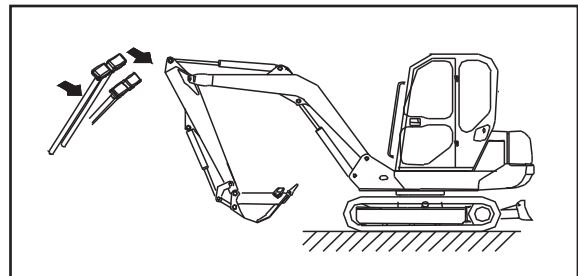

Caution: When it is the lower temperature, the driving speed of the machine doesn't right, it need to warm-up. Otherwise, if the bottom of the machine has the soil, the driving speed doesn't right, it need to clear the soil.

4. Moving the machine backward

1) Adjust the safety lock handle and the control box to the free station, lift the operation device and off the ground 40cm to 50cm

2) The operation is opposition forward

5. Stop the machine

Make the left&right joy stick to the middle, it stops the machine.

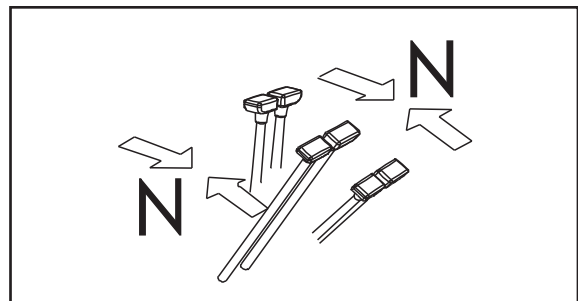

Caution: Avoid the machine stop suddenly, it need have enough space.

Turning The machine

Caution: Before operate the joy stick, it need to check the station of the bulldozer. If the bulldozer in back, the operation reverse

Use the left&right driving joy stick to replace the direction of the driving.
Avoide to replace the direction sudden as far as possible.

1. Turn the direction when the machine stops

Turn left:

Driving forward, pull the right driving joy stick, the machine will turn left. Driving backward, push the right driving joy stick, the machine will turn left.

Turn right: the mode same as turn left.

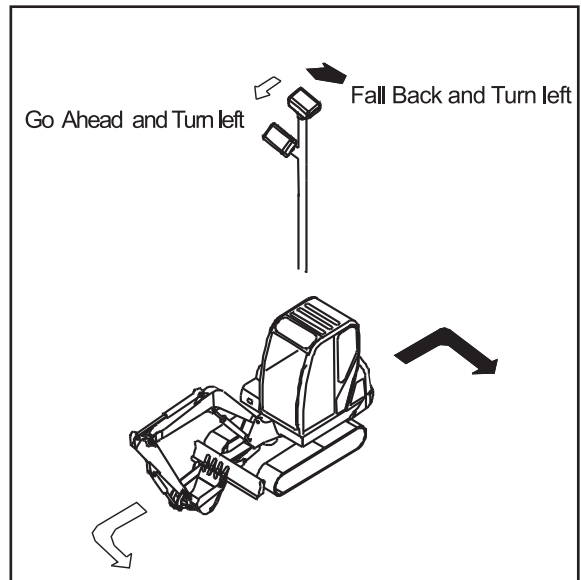

2. Turn the direction at the same place.

When the machine is turn left at the same place, push the left driving joy stick and pull the right driving joy stick.

When the machine is turn right at the same place, push the right driving joy stick and pull the left driving joy stick

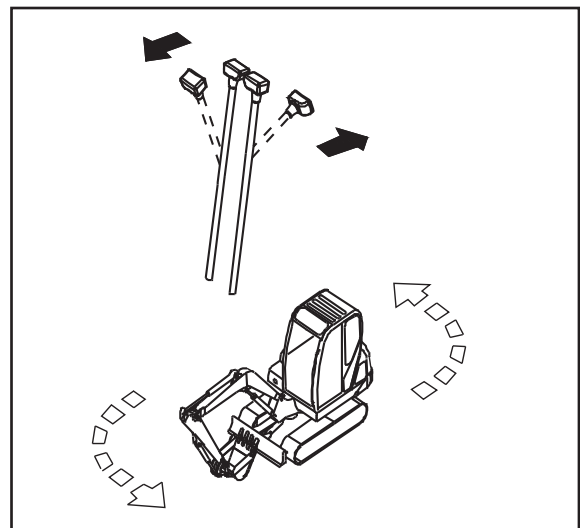

Rotating The Machine

- Before rotate the top frame, it need to check whether the area safe.
- Make sure already to lift up the lock pin of the platform, unlock the platform and the bottom plan.
- If it operates the rotating joy stick fast, the top frame turns fast, too. If it operates the rotating joy stick slowly, the top frame turns slowly, too.

1) Before do rotation operation, it needs to lift up the lock pin of the platform, unlock the platform and the chassis.

2) If the machine has the rotation head, it need to operate the choice button of the left operation device joy stick, to make sure the machine stay the station of the platform rotating.

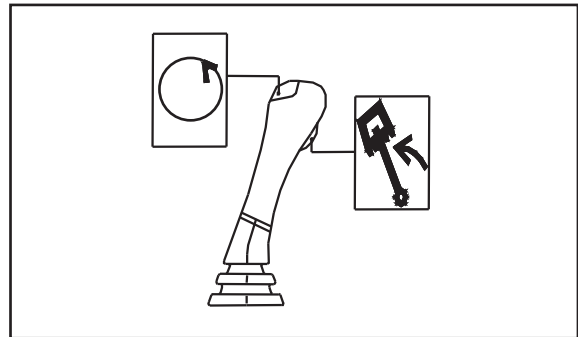

3) Operate the left operation device joy stick to do the rotating operation

4) If it doesn't do the rotating operation, it needs to insert the orientation pin of the platform, lock the platform rotate.

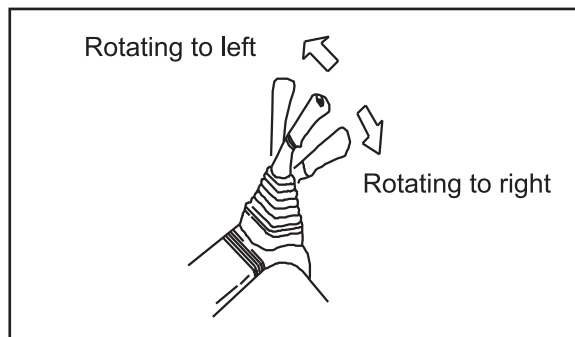

Operate The Operating Device

If it operates the joy stick of the operation device fast,the operation device moves fast,too. f it operates the joy stick of the operation device slowly,the operation device moves slowly ,too

The operation device operated by the left/right operation control valve.The left operation control valve operates the lever and the rotating(if it has the rotation head,the left operation control valve can operate the head move).The right operation control valve operates the moveing–arm and the bucket.

Lossen the joy stick,they will return the middle by automatic.The operation device keep on the original.

If it operates the control valve in 15 seconds when stop the engine,it can down the operation device.

And it also can operate the control valve to release the rest power of the hydraulic oil line and down the moving–arm after the machine has the trailer.

1.Control the lever

Operate the left operation control valve, push forward, the lever extends; Pull backward, the lever draw in

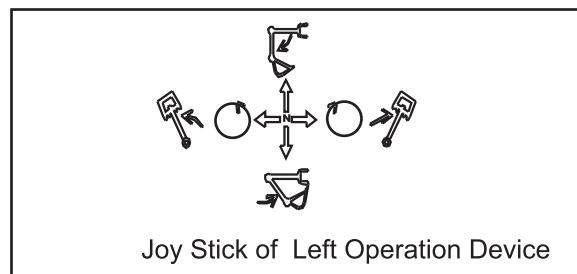

2.Control the rotating

Operate the left operation control valve, deflect to left,the platform turn left.Deflect to right,the platform turn right.

If the moving arm has the deflecting function,it must make sure the machine stay the rotating state before it rotating.

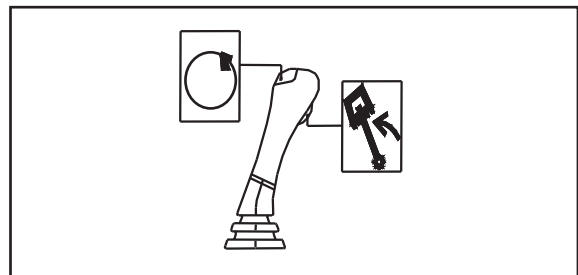

3.Control the moving-arm

Operate the right operation control valve, push forward,the moving–arm down;Pull backward,the moving–arm up.

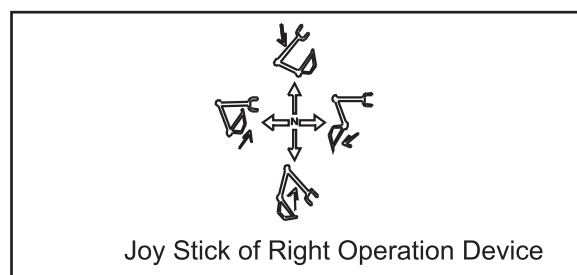

4. Control the bucket

Operate the right operation control valve, deflect to left, the bucket eversion. Deflect to right, it draw in

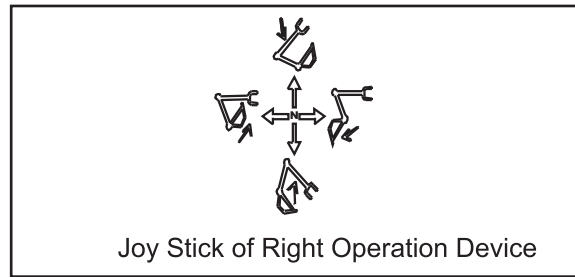

5. Control the moving-arm deflecting (the rotation head)

Operate the left operation control valve, deflect to left, the rotation head turn left. Deflect to right, the rotation head turn right.

If the moving arm has the deflecting function, it must make sure the machine stay the moving-arm deflecting mode before it rotating

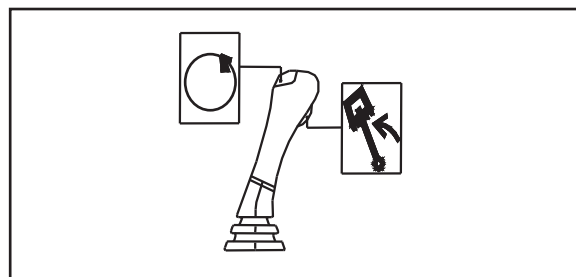

6. Control the bulldozer

Push-down the joy stick of the bulldozer, the bulldozer into the soil. And pull-up the joy stick, the bulldozer lift up.

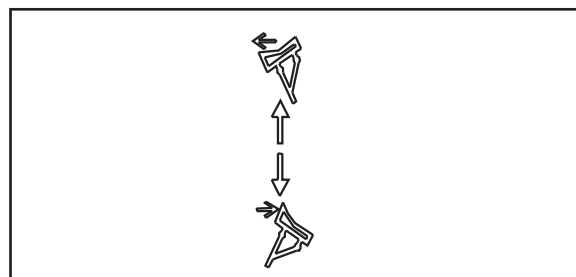

Caution: When the lever operated, it maybe pause. It doesn't the trouble, it is the normal phenomenon. When the lever moves, it maybe lack the oil because of the deadweight to make it move fast.

Working On The Slope or In The Water



Warning:It is dangerous to work near the slope of the piedmont.

- When the machine drives, the bucket should be away from the ground 20–30cm
- No back up on the slope.
- When the machine drives on the roadblock, it should make the operation device close to the ground and drives slowly.
- No swerve on the slope or cross the slope. It can turn the direction on the smooth ground.
- It will overturn when the machine swerves or operates the operation device on the slope. When the bucket overloads, it's very dangerous to rotate to the direction of the downgrade. If it must do, it needs to use the soil to stack a flat roof and to make the machine keep the balance.
- No up&down the slope, it maybe have the danger.
- When the machine is upgrade, if the pedrail skids or the power of the pedrial not enough to upgrade, no use the pull power of the lever to help it. Maybe the machine will overturn.
- When the machine upgrade, it needs to make sure the engine and the hydraulic oil warm-up.

The depth of the water which it allows

No drives the machine when the depth

No drives the machine when the depth of the water exceed the center line of the bracket.

It needs to lubricate the butter when the parts in the water long time, till the butter which used all out.

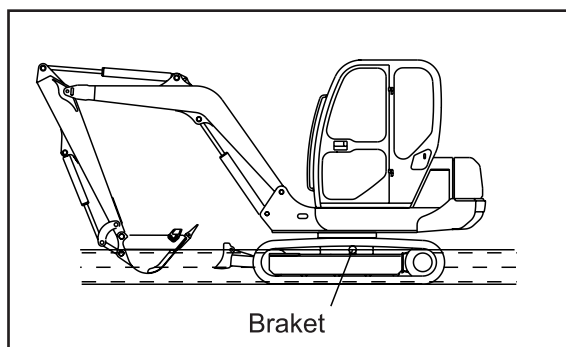

Out of The Muddy Condition

It needs to operate the machine careful to avoid get into the mud.If the machine gets into the mud,please do as follow:

A.One side of the pedrail gets into the mud

Caution:When it uses the moving-arm or the lever to uplift the machine,it must make the bottom of the bucket touch the ground.(No use the gear of the bucket to push).The angle of the moving-arm and lever is 90° to 110°

When it only one side of the pedrail gets into the mud,it uses the bucket to uplift the pedrail,and underlay the stow-wood, make the machine drive out.If it necessary it can underlay the board under the bucket.

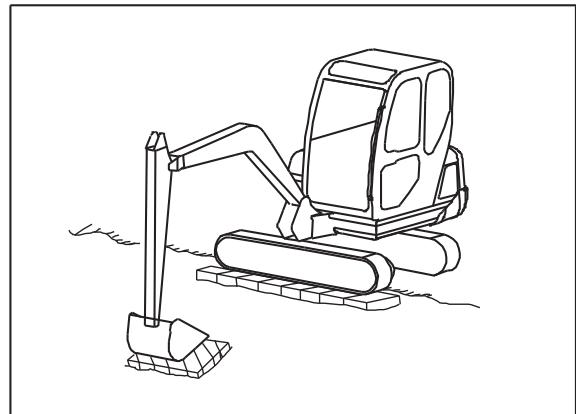

B.Double sides of the pedrail get into the mud

If the double sides of the pedrail get into the mud,and skip not to move.It can adopt the way which as A to underlay the stow-wood.It makes the bucket dig into the ground,and operate the joy stick same as the way which it digs.And adjust the joy stick of the driving to the station which go ahead to pull out the machine



Operating Manual

1.Operation when the bucket in reverse

The bucket in reverse suit for the station under the machine

When the machine stay the state which like the picture,when the angle is 90° for the oil tank of the bucket and the lever、 the oil tank of the lever and the lever,it can have the max. digging power of the bucket.

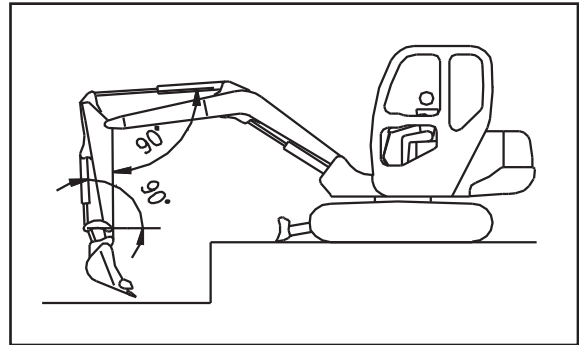

If it uses the angel effective when it digs,it has the best efficiency.

The dig area of the lever is 45° away the machine to 30° towards the machine.

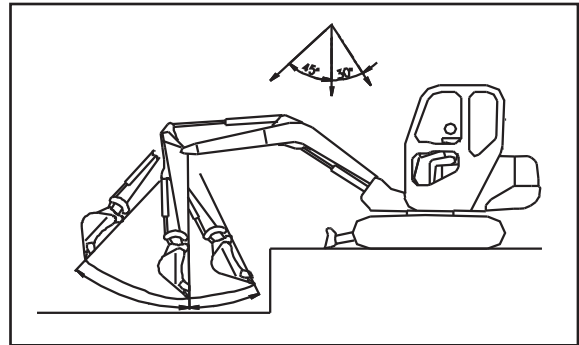

Caution:If the machine digs the hard ground,it is the best way to use other tools crash it then digs.

2.Operation when the machine loading

On the place which the angle of the rotating small, it let the truck stop the place which the operator can see easy. If the truck loads from the back easier than from the side,the loadage is more.

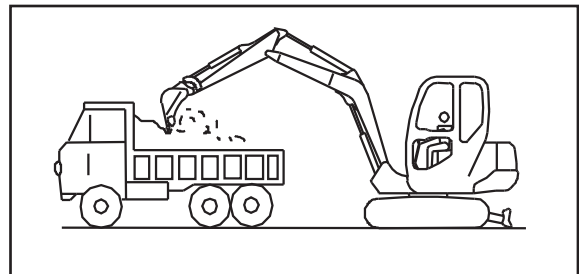

3.Operation of dig the ditch

Make the bulldozer back and anchor into the ground.

Throw out the moving–arm and the lever,and meke the gear of the bucket into the ground.

Use the oil tank of the lever to dig.It need to adjust the angle of cut–in and load the soil when it digs or choice the oil tank of the bucket to digs.It doesn't make the gear of the bucket into the soil too deep, lest should the hydraulic system overload and not have the power to dig.If it doesn't have the power to dig,it can uplift the moving–arm.After full of the bucket,lift up the moving–arm and the lever,make the bucket higher than the ground,and turn the platform the right place to unload the soil.

Caution:

1)No touch the wire

2)After make clear the under-pipe、 the cable,then start dig.

3)If it gets an electric shock,the driver dosen't leave the seat,and warn the person not close.After the machine on the safety area and cut off the electricity,then leave.

4.Backfill

For backfill the ditch,the driving direction of the digger should plumb the ditch.And after the bulldozer cut–in the soil to the certain depth, loosen the joy stick of the bulldozer,start the driving,and use the bulldozer push the soil into the ditch.

5.Shake down the sandy and the soil which in the bucket

Make the lever stay the level state,the bucket stay the unload state.If the sandy and the soil don't down,and operate the operation handle of the bucket some time with left&right,the sandy will shake down. Avoid use the driving end of the bucket's oil tank to percussive libration to shake down them.

6. Notice for relevant parts

A. Notice for crawler

- 1) Too many objects enter into the crawler will cause damage.
- 2) Avoid suddenly turning around the machine on a hard friction ground.
- 3) Try to avoid touch brine, it will erode the crawler.
- 4) If the crawler does no use for long, keep it in a dry and cool place.
- 5) When one of the crawlers is lifted, do not move the other crawler, this will cause the crawler fray.
- 6) when machine moving, do not loose the crawler, otherwise crawler may drop out.

B. Notice for using dozer blade.

1) Dozer blade could only be used to push the earth. Do not use it for other purpose, otherwise dozer blade and crawler may be damaged.

2) Dozer blade could not endure huge heavy object.

3) When machine traveling, do not hang any object on the blade.

4) When using blade to lift up the machine, make sure on a flat and reliable ground.

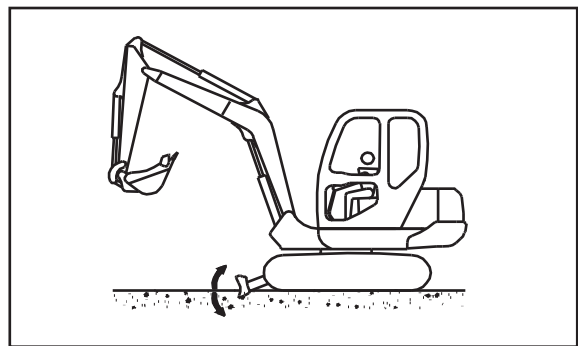

Take-down & Installing The Bucket

Safety rule

- When it uses the hammer to knock the pin bearing, the slug may be into the eye to make the hurt. When the person deal the operation, it need wear the safety glass、 motorcycle safety helmet、 the glove.
- When it take-down the bucket, it need to put it steady.
- When it uses the hammer to knock the pin bearing, it maybe fly off and hurt the person who in the around area. So before knock the pin bearing, it should make sure the are safe.
- When it take-down the pin bearing, no stand under the bucket, no let the foot or other parts of the body under the bucket.
- When it take-down or installing the pin bearing, caution no hurt the hand.
- When it make the hole in line, no put the finger into the pin bearing.

Installing

Stop the machine on the ground which hard and smooth. When it do the connect work, it should know the signal and work careful.

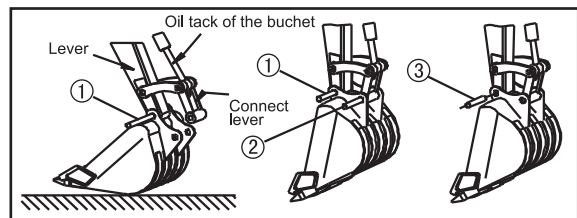

Make the digger stay the operation state, envisage the bucket, operate the lever till the hole of the lever and the bucket in line, and inset one steel stick ($\Phi 30\text{mm}$, ①) into the hole

Lift up the moving-arm and the lever to make the bucket hang on the lever vertical. Operate the oil tank of the lever to make the holes of the connect lever and the connect hole of the bucket in line. Installing the bearing ②, take out the steel stick ① and installing the bearing ③。

Take-down

Stop the machine on the ground which hard and smooth. It request to put the bucket to the place which can touch the ground. If the bucket fall down heavy, it will increase the resistance and difficult to take-down the pin bearing.

Take-down the double nuts of the lock bolt which connect the lever and the connect lever, and take-down the bolts, then tak-down the pin bearing ③ and the pin bearing of the connect lever ② and take-down the bucket

Place The Machine

Safe rule

1) Avoid to stoping the machine suddenly.
When it places the machine, it need have enough space.

2) Place the machine on the ground which hard and smooth. No place it on the slope. If it must places the machine on the slope, it need put the stow-wood under the pedrail make the operation device inset the ground.

3) If it touches the joy stick of the operation device incautious, the operation device or the machine moves, it will lead the accident. So before leave the seat, it must to lock the joy stick of the safety lock .

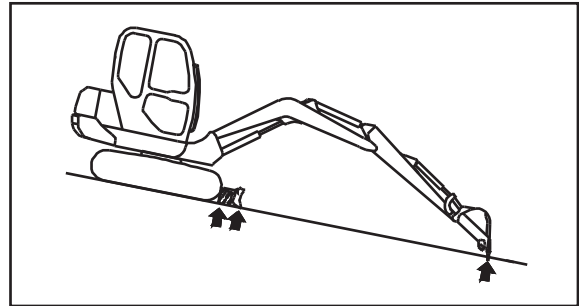

Machine stop

- 1) Put all levers in neutral position.
- 2) Don't stop the engine abruptly before it is cool enough. If the engine is over heated let it run at low speed for 5mins then stop it.
- 3) Lower bucket and dozer blade on the ground.
- 4) Put the throttle lever in low idle, and pull the stop lever rearwards in the end (If there is the stop lever).
- 5) Rotate the start key in "OFF" until the warning lamps go out.

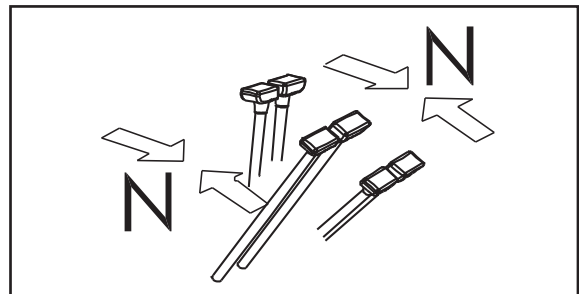

6) Move the engine stop lever in clockwise until the engine stop completely.

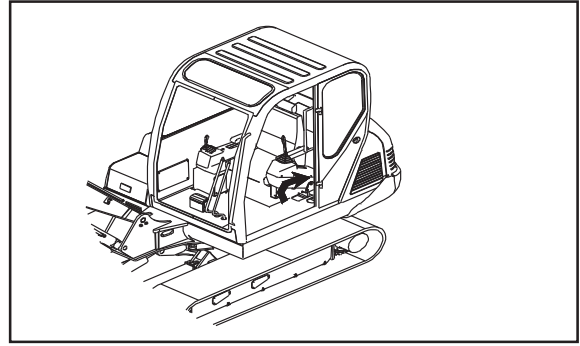

CHECK AFTER COMPLETION WORK

1.Check

Check the water temperature、 engine oil pressure、 fuel pressure、 the level of the fuel on the instrument panel.

2.Lock

After completion work , make sure the follow compartment is locked.

1)Cab's door. (And don't forget the windows). In any condition, if you want to open the front windows, using the handle , can pull the front window up and down to slide the roller inside the guide, then lock it to upthrust till the lock position, whereas, put the front windows down.

2)Refuel port.

3)Hydraulic oil filing port.

4)Battery-box cover

5)Engine hood

Warning: Make sure that there is nobody stand by engine hood when opening the engine hood to avoid hurt.

TRANSPORTATION

1.Safety regulation for loading machine

- 1)When loading or unloading the machine, run the engine at the idling speed.
- 2)Don't loading or unloading the machine when turn on the heater.
- 3)If you turn off the heater when operating the machine, the speed of machine's movement will suddenly change.
- 4)When loading or unloading the machine, park the trailer on a flat, firm road. Keep a fairly long distance between the road shoulder and the machine.
- 5)Make sure the ramp has sufficient width, length and thickness to enable the machine to be safely loaded and unloaded. And set the distance between ramps 1.2-1.5 times as much as the track width. In order to avoiding accident, advise to make the angle of the gangplank a maximum of 15° or the length of ramp is greater than the height 2.5 times.
- 6)Keep the crawler off mud and dirty to prevent from slipping on the slopes. Make sure the slope is cleanness, no water, snow, ice, lubricating grease or oil.
- 7)Never change the direction of travel when on the ramps. If it is necessary drive off the ramps and correct the direction, then drive on to the ramps again.
- 8)Don't use the work equipment to load or unload the machine.
- 9)Don't operate any lever besides walking lever when the machine is on the ramp.
- 10)The machine's focus may be suddenly changed at the joint of the ramp and trailer which may cause the machine lose balance. Therefore, carry out the operation slowly when pass through the joint.
- 11)When turning the machine on trailer, the machine's footing is unstable, so the work equipment should be retracted when slewing.
- 12)No matter loading or unloading the machine, there must be some blocks beneath the tires to ensure the trailer doesn't move.
- 13)Place rectangular timber underneath the front and rear track shoes to prevent the machine from moving about. Also, hold it down with chains or ropes.
- 14) After completing work or operating, before the operator leave the seat, make sure the pilot operating oil circuit is cut off by lifting the safety lock lever, in case that somebody impact the operating lever accidentally what cause the machine move.

2 . Loading precaution

1)When loading or unloading the machine, park the trailer on a flat, firm road. Keep a fairly long distance between the road shoulder and the machine.

2)Properly apply the brakes on the trailer and insert blocks beneath the tires to ensure that it does not move.

3)Make the angle of the gangplank a maximum of 15°. Set the distance between the ramps to match the centre of the tracks.

4)Let the excavator and the ramp in the line, the bulldozer stay in the backside, for safety reason, the excavator should drive slowly when climbing the ramp until reach to the end of the ramp.

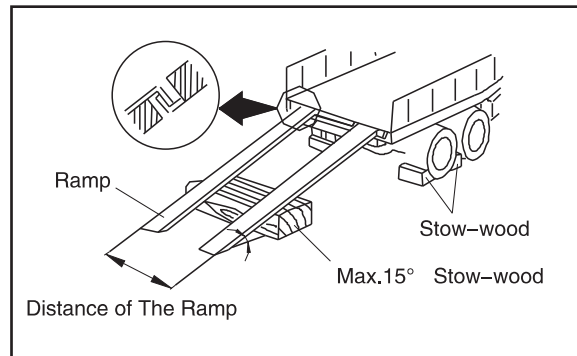

NOTICE: when you are on the ramps don't operate any lever besides the travel lever.

5)Set in direction of the ramps, then stop walking to extend the arm (B), enable the front of crawler load the trailer's floor. Lower the work equipment for fear it hitting the trailer, then travel slowly to load or unload the machine correctly in the specified position on the trailer.

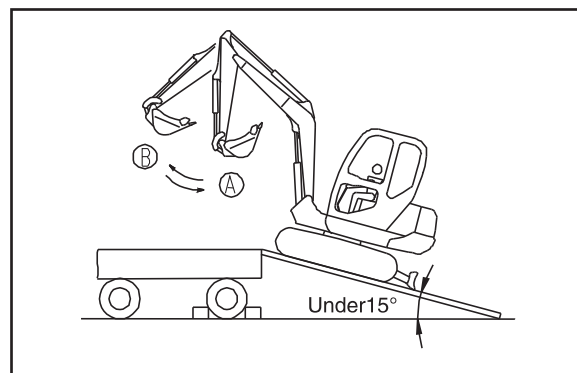

6)Lower down the arm slowly and make the bucket contact with floor, then lower down the blade, load the machine correctly in the specified position on the trailer.



WARNING: After completing work or operating, before leave the seat, the operator should lift the safety lock lever at first to make the pilot operating oil circuit is cut off. For in case that somebody impact the operating lever accidentally what cause the machine move.

NOTICE: Choose the trailer to match the machine in weight and size offered in this manual

3. Fix the machine on the trailer

- 1) Lower the work equipment correctly
- 2) Stop the engine and remove the start key.
- 3) Lift the safety lock lever up
- 4) Lock the door and engine hood
- 5) Place rectangular timber underneath the front and rear track shoes to prevent the machine from moving about. Also, hold it down with chains or ropes. Be particularly careful to ensure that the machine does not slip sideways.

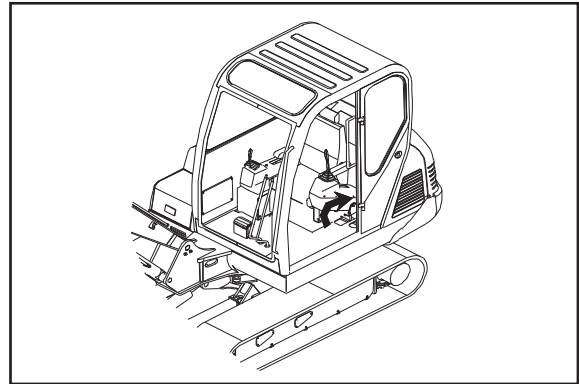

4. Unload the machine from the trailer

- 1) When loading or unloading the machine, park the trailer on a flat, firm road. Keep a fairly long distance between the road shoulder and the machine.
- 2) Properly apply the brakes on the trailer and insert blocks beneath the tires to ensure that it does not move.
- 3) Fix ramps in line with the centre of the trailer and the machine. Be sure that two sides are at the same level as one another. Make the angle of the gangplank a maximum of 15°. Set the distance between the ramps to match the centre of the tracks.
- 4) Remove the chains or ropes on the machine.
- 5) Start the engine. If it is winter, turn on the heater to warm the machine completely.
- 6) Put the safety lock lever down.
- 7) Lift the arm and bucket, and raises blade
- 8) Make sure no unauthorized obstacles in the working area.
- 9) Moving the platform lock pin and slewing the machine 180°, operate the work equipment to face to the ramps.
- 10) Run the engine at the idling speed then travel slowly till the top of the ramps, then extend the arm when the machine loads on the road,

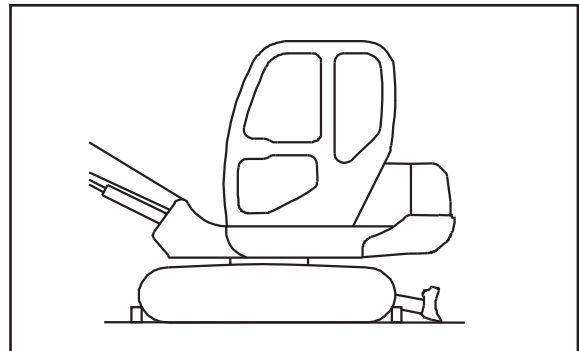

5 Suspend the machine

A. safety regulation

- 1) Don't suspend the machine when there is somebody on it.
- 2) It must be sure the chain that use to suspend the machine have the enough intensity to carry the weight of the machine.
- 3) In order to avoid the machine's unbalance, it must do just like following provided steps.
- 4) Don't suspend the machine when the above body doesn't parallel with the track. And only when they parallel, it can use the chain to suspend the machine.
- 5) When in the process of lifting, it must keep the machine in horizontal.
- 6) When in the process of lifting, there must be nobody under the machine or around the machine.

B. Suspending procedure

NOTICE: the suspending procedure is used for the standard machine. The suspender must be used the professional tool that can carry the weight of the machine enough.

When suspending the machine, it must be at the smooth floor before doing the following procedures.

- 1) Slew the a above part of the machine to in line with the wheel of the chain.
- 2) Let the cylinders of the arm and boom unwind, until the working equipment on the floor.
- 3) Stop the engine, make sure there is nothing else in the cabin, then leave the machine. Close the door of the cabin and the window.
- 4) Tightwire have to get through the front idler and idler of wheel in the front of the machine, meanwhile it also have to get through the driving wheel and pedrail supporting wheel in the back of the machine.Or putting the tightwire to get through the machine under its pedrail.

5) Firstly, we have to adjust the rising angle of the tightwire to 30 or 40 degree, then we can slowly rise the machine .

6) When the machine lifted above the floor, check if the machine is balance, then lift it up slowly.

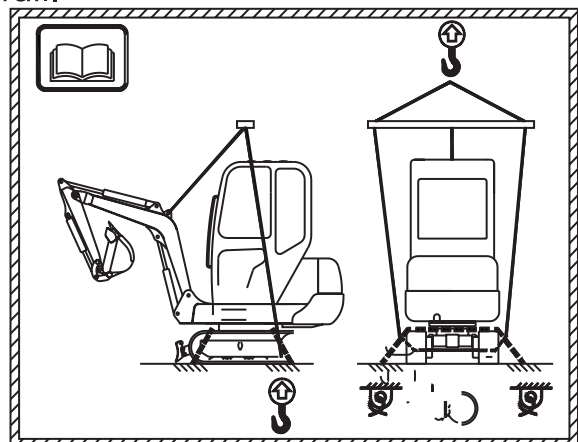

COLD / HOT WEATHER OPERATION

1. Cold weather operation

The cold weather may cause some trouble, so the protection is very important at this time. Avoiding the machine to be badly damaged, if maintain machinery adequately, it will extend machinery life.

1)Electrical system: keep the battery clean and charge fully. Check the cable and joint, clean the joint then apply a layer of grease at it to prevent it from rusting

2)Lubricants: apply the lubricant moderate in viscosity at every joint. Please use the recommended lubricant fit for this machine.

3)Fuel system: check if the fuel supply is suitable for the cold climate at that time, and change into fuel in low viscosity.

Check if there is water in the fuel system. In cold weather, moisture content will gather in the fuel box, so check whether there is moisture content in the fuel filter once working every 50 hours each time. If there's no water inside, extend the inspection cycle, or else, check the oil tank.

4)Cooling system: before operating the machine in cold weather, it is necessary to check the coolant if it is mixed at a suitable proportion, and the coolant must be the right one which is fit for the environment temperature.

5)Work equipment: before starting the engine, put the throttle lever in low idle, start the machine slowly, then stop traveling to operate the work equipment for about 10mins or till every hydraulic cylinder working normally.

2. Hot weather operation

To avoid the machine is damaged, follows these rules:

1)Make sure the quantity of liquid coolant in radiator is normal

2)Before the hot weather coming, check the radiator and change the coolant if necessary.

3)Removing the dirty and fouling on the surface of radiator and engine.

4)Check the fan belt.

5)Use the lubricant in moderate viscosity.

6)In the cooling system, use the appropriate mix of coolant.

7)In the condition of the large dusty environment, air filter should be often checked.

LONG TERM STORAGE

1.Before storage

When putting the machine in storage for a long time, do as follow:

- 1)After every part is washed and dried, the machine shall be housed in a dry building. Never leave it outdoor. In case it is indispensable to leave it outdoors, park the machine on a flat road and cover it with canvas etc.
- 2)Apply a thin coat of grease to metal surface of the hydraulic piston rods.
- 3)Removing the battery, which will be fulfilled with the electrolyte and electricity and then put it at a not dry ice-free areas.
- 4)Drain the engine oil at the warm state, and change with anticorrosion oil. For the piston-type engine the anticorrosion oil MIL-L-21260 is selected. For a winter storage use 1.grade or 2.grade SAE 10W, but for a summer storage use SAE 30.
- 5)Fill also the same type of the anticorrosion oil for about 4%~6% in the fuel oil, and mix them completely. In order to prevent from bringing about condensed water, refill the fuel tank with this kind of mixed oil.
- 6)Check the antifreeze function of the coolant. By filling with antifreeze, its antifreeze ability is at least 20*. There is non corrosion inhibitor in coolant because of the climate, you should fill with corrosion inhibitor.(it contains 5% corrosion inhibitor according to MIL-G4339C.)
- 7)Start the engine, run it above 15mins at different rotational speed and without load.
- 8)Shut off the inlet of the air filter and the outlet of the exhaust pipe. Plastic thick papers and tape are recommended in this case.
- 9)Lock the platform, and set the safety lock lever in lock position*the left operating box*, set all levers in lock position.
- 10)Keep the machine clean, and place it in a dry space.
- 11)Lock the cut-off valve which for install the attachment, and installing a bolt in the elbow.

NOTICE: When the machine is not being used, set the work equipment as showed in beside figure. This will prevent the cylinder rod from rusting.

2. During storage

- 1) Start the engine and travel the machine for a short stretch every month, so a thin coat of grease will cover the moving parts. At the same time, charge the battery.
- 2) Also run the air condition if it is assembled.
- 3) Turning the crawler.



WARNING: When the machine housed in the building, if the antirust operation should be done, open windows and doors to improve the ventilation and prevent gas poisoning.

3. After storage

When you start the machine after a long term storage, do as follow:

- 1) Remove the excess grease with a duster from cylinder rods.
- 2) Add oil and grease to all place.
- 3) After the machine have stored for a long time, moisture content in the atmosphere may mixed in the oil. Before or after starting the engine, you should check the oil at all places. If the oil mixed with some water, the oil at all places should be changed.

NOTICE: 1) According the climate, the machine can be stored for a year by means of above method. However, after storing for six months, you should operate every part for 15mins without load. At the same time add the lubricant to every part.

2) Before operating the machine again, which have stored for a long time, you should do some necessary inspection. After stored over a year, the machine must be drained out and change the oil from its reducers and hydraulic system, too.

Reason for the Technical Trouble & Resolve

Trouble	Reason	Resolve
1. The engine couldn't start or start difficult	● Problem for start the engine	● Replace or check the engine
	● Lack electrification of the battery	● Electrification or replace the battery
	● Error use for the line or the piston of the warm-up	● Mend or replace the warm-up piston
	● Error of the oil injection positive	● Check the oil injection positive
	● The pipe laying obstructed	● Clean the pipe laying
	● The filter of the fuel obstructed	● Clean or replace the filter of the fuel
	● The fuel system has the water, the dust or the air	● Ejectment the air, clean the pipe laying
	● The nozzle dirty or the pressure of oil injection lower	● Maintain the nozzle
	● The trouble of the fuel injection pump	● Contact assistant service
	● The fuel lacks	● Immit the oil
	● The intake/vent system obstructed	● Ejectment the trouble
2. The engine knocking, running irregularly or stop	● It have many air	● Contact assistant service
	● The filter of the fuel obstructed	● Clean the filter
	● The fuel system has the dust or the air.	● Vent and clean the oil line
	● The filter obstructed, the nozzle dirty or trouble	● Check them
	● The high-pressure oil pipe destroyed	● Replace the high-pressure oil pipe
	● The fuel lacks	● Immit the oil
	● The velometer couldn't adjust	● Contact assistant service
	● The trouble of the fuel injection pump	● Contact assistant service
● Error of spurt oil positive or the nozzle clip	● Check them	

Trouble	Reason	Resolve
3. The power of the engine descend	●The fuel has the air	●Ejectment the air
	●The pipe laying obstructed which supply the oil	●Check and clean it
	●The oil injection positive replaces	●Adjust it with the ordain value
	●The oil injection work not good	●Check the working pressure and the pulverization of the nozzle
	●The air filter obstructed	●Clean the core of the filter
	●Error of the intake vent or not seal	●Adjust the gap of the intake/vent
	●The cylinder cushion bad or leak	●Replace the cylinder cushion
	●The oil injection pump work not good	●Contact assistant service
	●The engine overheat	●Check whether use the coolant right. whether the water pump and the belt loose .If they have, it need to mend or replace them, and clear the choker of the flume
4. The engine overheat	●The level of the coolant low	●Immit the coolant
	●The temperature sensor has the trouble	●Replace the sensor
	●The air filter obstructed	●Clean the filter
	●The belt of the fan looses or trouble	●Screw down it again or replace
	●The pipe of the cooling system has the dust	●Clean the pipe
	●Bad machine oil or much the machine oil	●Replace the machine oil
5. The pressure of the engine low	●The level of the machine oil low	●Immit the oil
	●The filter of the machine oil Obstructed	●Clean the filter of the machine oil
	●The pipe leaks oil	●Screw down or replace
	●The coolant of the engine Exorbitant	●Mix the coolant with the right rate or contact assistant service

Trouble	Reason	Resolve
6.The engine emit the black smoke	●Bad fuel	●Use the better fuel
	●The air filter obstructed	●Replace the core of the filter
	●Error of the oil injection positive	●Adjust it with the ordain value
	●The pulverization of the nozzle not good	●Check and replace the parts
7.The engine emit the withe smoke	●Bad fuel	●Use the better fuel
	●The machine oil of the engine more	●Renew the level of the oil
	●Error of the oil injection positive	●Adjust it with the ordain value
	●The oil tank &the fuel have the water	●Check and replace the fuel
8.The electricize battery not	●The tie-in looses or rusts	●Clean or screw down
	●The belt of the engine loose or trouble	●Screw down or replace
	●The engine not electricize	●contact assistant service
9.The engine not run or run slow	●The tie-in looses or rusts	●Clean or screw down
	●The battery undercharge	●Replace
	●The line destroy	●Contact assistant service
10.The engine runs,but the alarming light lights	●The engine has trouble	●Contact assistant service
	●The electron adjuster has the trouble	●Replace
	●The line has the trouble	●Check and repair
11.The part of the hydraulic system runs slow	●The hydraulic oil cool	●Warm-up
	●The pressure of the guide system low	●Contact assistant service
	●Error use of the hydraulic oil	●Use the hydraulic oil which right
	●The speed of the engine too Slow	●contact assistant service

Trouble	Reason	Resolve
12.The temperature of the hydraulic oil too high	●Error use of the hydraulic oil	●Use the hydraulic oil which right
	●The pipe laying obstructed	●contact assistant service
	●The oil filter of the hydraulic oil obstructed	●Clean or replace
	●The oil pump attrite	●contact assistant service
	●The oil cooler obstructed	●Clean the oil cooler
	●The oil cooler has trouble	●contact assistant service
	●The pressure of the main safety valve or the spill valve too high	●Contact assistant service
	●The oil too dirty	●Replace the oil
	●The senor has trouble	●Replace
13.The hydraulic emulsification or has the foam	●The pipe which from the oil tank to the oil pump leak	●Check and repair,and screw down
	●Error use of the hydraulic oil	●Use the hydraulic oil which righ
	●The hydraulic oil includes the water	●Replace the oil
	●The level of the oil too low	●Check the level of the oil
14.The pressure of the oil too low or not	●The hydraulic pump destroy	●contact assistant service
	●The oil lacks	●Immit the oil
	●The safety valve has trouble.	●contact assistant service
15.All parts no work	●The hydraulic pump destroy	●Contact assistant service
A.The oil pump has the noise	●The hydraulic oil lacks	●Immit the oil
	●The oil suction pipe leaks	●Repair or replace
B.The noise of the oil pump not replace	●The donkey pump destroy	●Replace
	●The operation device of the hydraulic safety not working	●Check and repair

Trouble	Reason	Resolve
16.The oil tanks or the motor no working or no power to working	●The hydraulic pump destroy	●contact assistant service
	●The pressure of the main safety valve become low	●Adjust the pressure
	●The level of the oil low	●Immit the oil
	●The oil suction filter obstructed	●Clean the filter
	●The oil sealer destroy	●Repair or replace
	●The piston lever destroy and leak oil	●Repair or replace
	●The guide valve trouble	●Replace
	●The guide pipe rupture and leak oil	●Repair or replace
17.Double driving device not working	●The joint of the central rotating series oil	●Contact assistant service
18.One driving device not working	●The driving device destroy	●Contact assistant service
	●The control machine destroy	●Check and repair
19.Driving deviant	●The pedrail too tight or too loose	●Adjust it again
	●The performance of the oil pump reduce	●contact assistant service
	●The pedrail frame metamorphosed	●Repair or replace
	●The chain of the pedrail has the scree	●Repair
	●The control valve leaks oil	●contact assistant service
	●The performance of the motor reduce	●contact assistant service
20.The rotating deviant	●The performance of the oil pump reduce	●contact assistant service
	●The rotating motor destroy	●contact assistant service
	●The guide valve not working	●contact assistant service
21.The rotating discrete	●The rotating gear attrite	●contact assistant service
	●The rotating bearing or ball bearing attrite	●contact assistant service
	●The axunge lacks	●contact assistant service
	●The control valve leaks oil	●contact assistant service

Trouble	Reason	Resolve
22.The air-condition system has the noise	●The joint of the electron looses, to lead the clutch not good	●Inter the joint tight or repaire
	●The belt looses	●Adjust it ,replace it if it broken
	●The fan of the blower looses	●Screw down agin
	●The blower works deviant	●Repair or replace
	●The electric fan works deviant	●Repair or replace
	●The bearing of the decrement machine destroy	●Replace
	●The tension bearing destroy	●Replace
23.The air-condition couldn't refrigeration	●The line trouble	●Repair or replace
	●The switch of the air-condition trouble	●Repair or replace
	●Not have the cryogen	●Check、 repair、 immit the cryogen
	●The system obstructed	●Clean or replace
	●The belt looses or rupture	●Adjust or replace
	●The expansion valve trouble	●Clean or replace
	●The decrement machine runs deviant	●Repair or replace
24.The air-conditioning is intermittent	●The line touch not good	●Check and repair
	●The belt loose	●Adjust the belt
	●The temperature of the air-condition switch adjust unsuitable	●Adjust
	●The system includes much water,the inside has the ice	●Replace the dryer
	●The electron fan or other relays destroy	●Repair or replace

5

Maintenance

Maintenance Information

Break-in of the new machine

The break-in period is the first 100 working hours of the new machine. Cautious use must be taken during this period in order to prevent the machine from heavy load and working intensity. In the first 50 hours in break-in period, only 80% of working intensity is permitted, because the proper use during the break-in period has a deep influence in the service life of machine.

After 50 working hours, the user must check the machine according to the maintenance list for the first time, and change the relative oil and filter. Meantime, to check the pollution degree of hydraulic oil, the degree must lower than grade NAS9 or the hydraulic oil should be changed.

When the hydraulic systems stop working, high speed running of the engine is prohibited. Working equipments can be used only if the temperature of hydraulic oil has exceeded 20°C.

Working in the dusty worksites

When the machine is working on a dusty worksite, please follow the below instructions:

- To check whether the air filter is clogged or not with the sensor and frequent cleaning of filter core is required.
- Clean the radiator core frequently to prevent the clogging.
- Frequent cleaning and change of fuel filter are required.
- Clean the electrical equipment, especially the starting motor and alternator in order to avoid the blocking of the dust.
- Move the machine to a clean ground for preventing dust from oil when checking and changing the oil.

Oil and the filter core

Clean engine oil and greases are required to avoid any impurity in the engine oil container.

After changed the oil and filter core, to exam whether there are cuttings or impurities in the old oil and filter core. Adopt proper measures if large numbers of cuttings and impurities are found.

Never mix different kinds of oil.

The hour meter

Check the hour meter in the instrument to see if it is the time to do maintenance for the machine.

Use the original spare parts

It is important to use the original spare parts of YUCHAI EXCAVATOR.

Environment protection

When dealing with the engine oil, fuel, coolant, anti-freeze, plastic, impregnant, filter core and battery which will be harmful to the environment, do abide by the environmental laws.

Do not drop anything into the machine

When checking the machine, pay attention to avoid dropping the bolts, nuts, spacers and tools into the machine, that will cause the damage to the machine and may bring accidents. If something has dropped into the machine, take it out immediately.

Periodical maintenance

Periodical maintenance should be undertaken according to the items in the Maintenance Schedule.

Counter checking

Counter checking is important after doing the maintenance every time. Please pay attention to the following instructions:

- Whether some parts of the machine which need to be maintained are missed.
- Assure that all items of maintenance have been carried out.
- To check if there is impurity has dropped into the machine.
- To check if there is oil, water and fuel leakage in the machine and make sure that the bolts are tightened.

Maintenance Outlines

Lubricants

- Use the right type of oil which is indicated in the “Oil List” and change the oil on a specified time.
- Prevent the lubricant from impurities (water, metal cuttings and dust etc.). Most problems with the machine are caused by these impurities.
- Do not mix the different lubricant.
- Add the lubricant to the right quantity.
- When change the lubricant, change the relative filter at the same time.

Fuel

- Be sure that no impurity will contaminate fuel when storage or refueling.
- Always use fuel specified in the “Oil Chosen list”. Fuel may freeze below -15°C , so it is necessary to change the fuel according to the environment.
- To avoid air condensation inside the fuel tank, refueling the tank after work.
- Before starting the machine or after refueling for 10 minutes, do let the deposits and water out of the tank.
- Exhaust the air in the oil circuit if the fuel of engine has run out or the filter has been changed.

Grease

- Grease is used to avoid the scratch wear and noise emission form jointed parts.
- To add grease after the parts are used for a long time.
- When adding the grease do remember to get rid of the old one.

Coolant

- Anti-freeze should be used under in different climate.
- Check the quantity of coolant in the tank and add it when the coolant is insufficient.
- Use the proportional mixture of coolant and anti-freeze according to the temperature.
- Never add the coolant when the engine is hot or not completely cool.

Filter

- Change the filter core periodically.
- Do not use the filter core which has been cleaned.
- When changing the filter, contact YUCHAI if you have found that there are metal grains on the filter.
- Do not open the package of the spare filter before usage.

Hydraulic system

- Check and do the maintenance on the hydraulic system after the temperature is down and release the pressure of the pipeline in the cylinder.
- When loosening the bolts, nuts and tie-in of pipes, do not stand at the front of the spare parts.
- Release the air in the pipeline when doing the checking and maintenance.
- The maintenance of hydraulic system consists of checking the quantity of hydraulic oil, changing the filter and refilling the hydraulic oil.
- When disassembling the tubes, the o rings must be changed if they are found broken.
- Do not use the contorted or bended tubes.

Electrical system

- If cables become damp or will damage, the electrical wiring may reduce machine safety and acting.
- If you wash the machine, be careful to prevent electrical wiring wets.
- To avoid radio interference between control device and walkie-talkie or radio system please check from YUCHAI before install anything.
- If you work near the seashore, keep the electrical wiring clean to avoid corrosion.
- If you install a fan or other electrical device connect it to an independent connector.

Oil choosing list

As the temperature of the condition , the using fact to choose the oil plants. But the oil plants must pass muster:

	Lube or Fuel	Use temperature	Viscosity	Fill-in
Lube of the engine	Chilliness area:CD10W/30 General area:CD15W/40	-20°Cupwards -15°C upwards	9.3-12.5 centipoise 12.-16.5 centipoise (when it is 100°C)	
Hydraulic oil	Low temperature:L-HS46 General area:L-HM68	-25°C upwards -4°C upwards	61.2-74.8 centipoise (When it is 40°C)	
Lube of the driving reducer	Overload use the gear oil (GL-5)	Winter/summer		SAE80W/90
Lube of the rotating reducer	Overload use the gear oil (GL-5)	Winter/summer		
Lube of the guide wheel/carrier wheel	Vehicle oil Hz-23	All the temperatures	20-25 centipoise (When it is 50°C)	
Lubricating oil	Lubricating grease	-20°C–160°C		
Fuel	Summer:0# light dies fuel Winter:-10# light dies fuel -20# light dies fuel	>0°C 0-5°C -5°C-15°C		
Coolant	Antifreeze (50%water and50%---Ethylene glycol)	>-32°C		
Refrigerant	R134a			

● The capacity of the Oil

Sort	Unit	Value
Fuel tank	L	48
Machine oil of the engine	L	7.6
Total of the hydraulic system	L	42
Hydraulic oil tank	L	35

The Tighten Moment

Refer to the value to install the bolts、the nuts.

The tighten moment of the general parts

Intensity Grade of The Bolt	Bend Intensity N/mm ²	Diameter of The Bolt mm							
		6	8	10	12	14	16	18	20
		The Tighten Moment Nm							
8.8	640	9~12	22~30	45~59	78~104	124~165	193~257	264~354	376~502
10.9	900	13~16	30~36	65~78	110~130	180~210	280~330	380~450	540~650
12.9	1080	16~21	38~51	75~100	131~175	209~278	326~434	448~697	635~847

Intensity Grade of The Bolt	Bend Intensity N/mm ²	Diameter of The Bolt mm						
		22	24	27	30	33	36	39
		The Tighten Moment Nm						
8.8	640	512~683	651~868	952~1269	1293~1723	1759~2345	2259~3012	2923~3898
10.9	900	740~880	940~1120	1400~1650	1700~2000	2473~3298	2800~3350	4111~5481
12.9	1080	864~1152	1098~1461	1606~2142	2181~2908	2968~3958	3812~5082	4933~6577

The tighten moment of hydraulic soft pipe

Rotating Nut with The Metric System Thread			
Metric System Thread	Outside diameter of steel tube	Nm	
		Moment	min./max
M12x1.5	6	20	15~25
M14x1.5	8	38	30~45
M16x1.5	8/10	45	38~52
M18x1.5	10/12	51	43~85
M20x1.5	12	58	50~65
M22x1.5	14/15	74	60~88
M24x1.5	16	74	60~88
M26x1.5	18	105	85~25
M30x2	20/22	135	115~155
M36x2	25/28	166	140~192
M42x2	30	240	210~270
M45x2	35	290	255~325
M52x2	38/42	330	280~380

The tighten moment of hydraulic soft pipe

BSP Thread and Rotating Nut		
	Nm	
BSPP Thread	Metric System Moment	Min./max
G1/4	20	15~25
G3/8	34	27~41
G1/2	60	42~76
G5/8	69	44~94
G3/4	115	95~135
G1	140	115~165
G1.1/4	210	140~280
G1.1/2	290	215~365
G2	400	300~500

ORFS Rotating Nut			
		Nm	
UNF Thread	Specs of the lineation	Min	Max
9/16~18	- 4	14	16
11/16~16	- 6	24	27
13/16~16	- 8	43	47
1~14	- 10	60	68
1.3/16~12	- 12	90	95
1.3/16~12	- 14	90	95
1.7/16~12	- 16	125	135
1.11/16~12	- 20	170	190
2~12	- 24	200	225

Maintenance List of Time-Check

Refer to the list and the calculagraph,time-Check and maintenance to the machine.If the condition of the machine bad or the working intensity strong,or it hast the hydraulic crash hammer and so on,the period of some parts maybe reduce.

No.	Item	Period of Maintenance (Total of the Working Hour)					
		10	50	100	250	500	1000
1	General Check						
	●Whether the machine oil、 water、 fuel leak	▲					
	●Parts of the machine and the appearance of the soft pipe	▲					
	●Fix circs of bolt and hydraulic joint	▲					
	●Circs of the operation device、 light 、 indicator light	▲					
	●Working circs of the diesel engine	▲					
2	Fuel System of The Engine						
	●Check the level of the oil and supply	▲					
	●Vent the water and the impurity			▲			
	●Clean the oil tank				▲		
	●Check the pressure of oil injection					▲	
	●Replace the filter core					▲	
3	Cooling System of The Engine						
	●Check soft pipe and cutting sleeve	▲					
	●Check the level of the coolant	▲					
	●Clean the vane of the radiator					▲	
	●Replace the coolant		☆				■
	●Check the consistence of the coolant	▲					
4	Lubricate System of The Engine&Other						
	●Check the level of the machine oil	▲					
	●Replace the machine oil		☆		▲		
	●Replace the filter core of the machine oil		☆		▲		
	●Check belt of the fan		☆	▲			
	●Check the gap of the valve					☆	▲
	●Check fastening circs of the cylinder					☆	▲
●Check fastening circs of the engine bearing		☆			▲		

No.	Item	Period of Maintenance (Total of the Working Hour)						
		10	50	100	250	500	1000	2000
5	Air Intake System of The Engine							
	● Break out the deposit tank	▲						
	● Clean the core of the air filter			▲				
	● Replace the core of the air filter					▲		
6	Hydraulic System							
	● Check the level of the machine oil	▲						
	● Vent the water and dust of the oil tank				▲			
	● Replace the hydraulic oil, clean the filter							▲
	● Replace the return oil of the hydraulic oil and the core of the guide loop filter		☆			▲		
● Check the pressure of the system					▲			
7	Accumulator							
	● Check the level of the electrolyte		▲					
	● Check the acidity and the state of the electrification					▲		
8	Pedrail							
	● Check and adjust the tension state of the pedrial				▲			
	● Check the level of the oil and immit						▲	
	● Replace the machine oil		☆			▲		
9	Reducer							
	● Check the tighten moment of the reducer which connect the bolt	▲						
10	Bear wheel , carrier wheel , guide wheel							
	● Check the tighten moment		☆			▲		
	● Check the level oil of the guide wheel/carrier wheel						▲	
11	Lubricate							
	● Immit lube to the point which need		▲					



Routine period to do



Maintenance of the first time to do



Every spring and Autumn

Routine Check

It need do the routine Check to the machine everyday or every 10hours.

- 1)Check whether the machine leak oil、 water or the fuel leaks
- 2)Check whether the parts and the attachment have the rupture、 the nick or the distortion
- 3)Check the hydraulic device's fix and connect
- 4)Check the appearance of the parts
- 5)Check the working circs of the operation device、 light 、 indicator light
- 6)Check the working circs of the engine.

Fuel System of the Engine

Maintenance manual

Capacity of the oil tank-----	40L
Check the level of the oil-----	10h
Vent the water and the impurity from the oil tank-----	100h
Clean the oil tank-----	250h
Check the pressure of the oil injection-----	500h
Replace the filter core of the fuel-----	500h

1. Check the level of the oil and immit

It can see the instruction sheet of the combination instruction sheet to Check the level of th oil.Do it everyday or every 10 hours. It should immit the oil tank after working to avoid have the hydrometeor.The gun stay front of the fuel-hydraulic oil tank

2. Vent the water and the impurity from the oil tank

Vent the hydrometeo and the impurity every 100 hours.

Loose the oil drain plug to make the hydrometeo and the impurity out.When the fuel out,please install the oil drain plug again. According to the quality of the fuel,the user can adjust the period to vent the condensation water.

3. Clean the oil tank

Clean it every 250hours

- 1)Vent the fuel to the container
- 2)Take-down the oil drain plug, take out the fliter.Top up half of the oil tank,and vent it again.
- 3)Clean the filter and replace.
- 4)Install the oil drain plug again.Through the fliter top up the fuel
- 5)Vent the air of the pipe laying

Caution:No use the trichlene to washing the inside of the oil tank,it only use the diesel oil

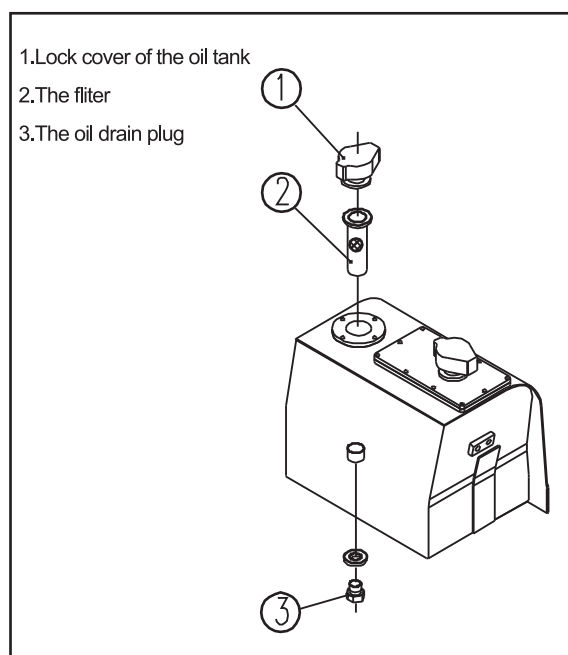

4.Exhaust of the fuel loop

It need to exhaust the air before start the engine when it replaces filter core of the fuel、 cut off the pipe of the fuel、 clean the filter of the fuel and make the air into the fuel loop.

Exhaust of YC25-2 type fuel loop

- 1)Open the vent nut of the base of the fuel filter
- 2)Run and press the pump piston till no air pour from the fuel
- 3)Close the vent nut.

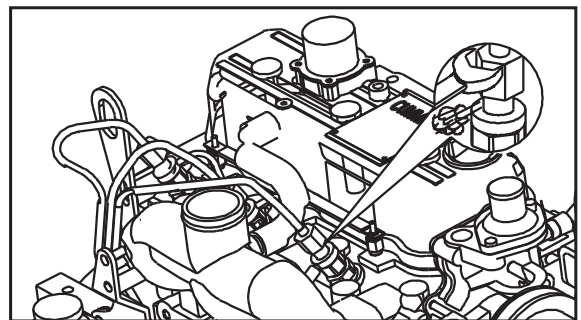
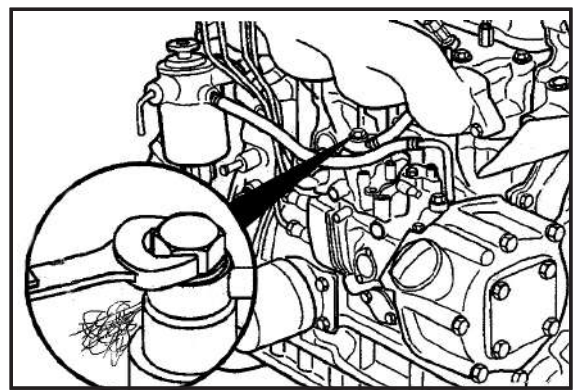
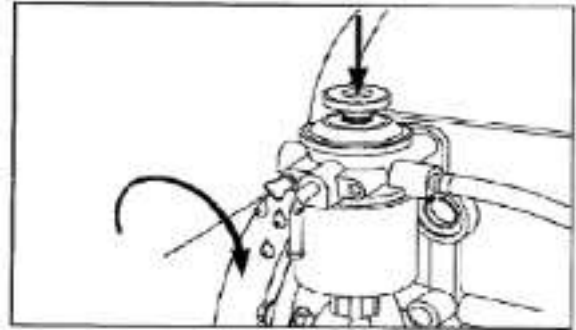

Warning:The pressure of fuel which from the high-pressure oil pipe can penetrate the skin and hurt the body.It should put on the glove and the sheathy work clothes before operating.

5.Pre-filter of the diesel oil

Change the filter core every 500hours

Vent the water and the dust of the separator everyday.

1)Stop the engine,open the outlet valve,and turn the valve about half and three circle counterclockwise till the valve drop down about 25.4mm(1 inch) and start to vent

2)Vent the water of the separator till see the cleanly fuel.

3)Screw down the valve clockwise when close the valve.

Caution:Don't screw the valve too tight.

It will destroy the thread.

6.Replace the filter core of the fuel

Replace it every 200hours or every 3 months.It must use the sterling filter core

1)Take-down the filter of the fuel

2)Use the cloth which not cottony to clean the surface of the sealing gasket.

3)Disuse the "O" ring.

4)Install the new "O" ring.

Caution:Check whether the base of the filter core has the old sealing gasket.If it has the old sealing wagher,it will leak oil.

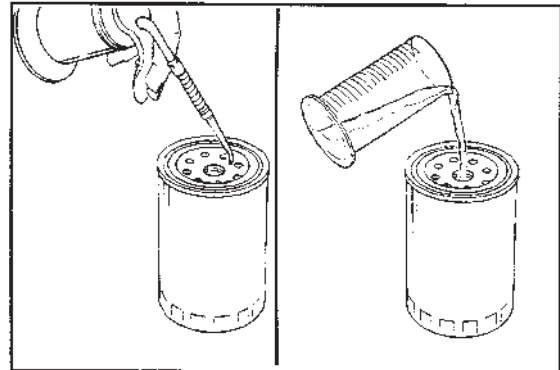
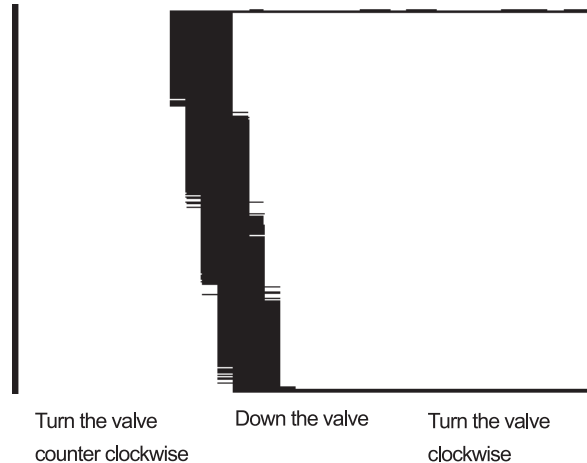

5) Use the new fuel top up the new filter, and use the clean machine oil to lubricate the "O" seal ring.

6) Install the filter as the manufacturer's order

Caution: For Reducing the feasibility of the fuel leaks, it make sure to install the filter fix but on too tight. Too tight will destroy the filter of the fuel.

7) After replace the filter core, start the engine and Check whether the surface of the seal ring leaks the oil.

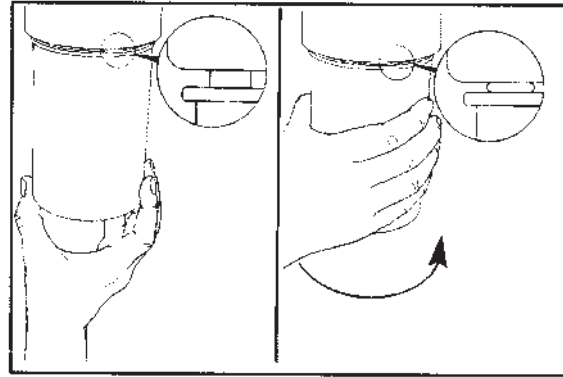

Cooling System of the Engine

Maintenance manual

Capacity of the radiator-----5.7L
Check the level of the coolant-----Everyday or 10h
Check the rubber soft pipe and the clip-----Everyday or 10h
Clean the vane of the radiator-----500h
Replace the coolant-----Spring and Autumn
Check the consistency of the coolant -----Everyday or 10h

1.Check the level of the coolant

When a new machine has been started, you must check the level of the coolant first. And check the level of the coolant everyday or every 10hours.

Take out the cover of the radiator (water tank), check the level of the coolant.

The level of the coolant should under the sprue about 20mm

Observe the position of the level in the balance tank.

The level of the coolant should lie in between the highest and the lowest level when the engine cooling.

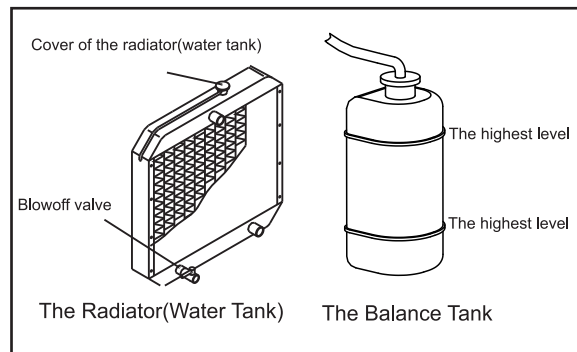

Warning: The hot coolant will spurt when open the cover of the radiator.

The way to open the cover: Open the cover little after the system cooled .Then wait it release the pressure.

2.Check the rubber soft pipe and the clip

Check it everyday or every 10hours.

It needs replace the soft pipe if it has the flaw or become hard because of the aging.

Check whether the clip locked,if it becomes less crowded or destroy ,it need replace it in time.



3.Clean and Check the vane of the radiator

Clean it every 500hours.

It need clean it in time.Because the dust of the radiator(water tank) will affect the effect of the cooling.

Open the cover,and use the high–pressure water or the compress air to blow the dust or the leaves and so on.Meantime,it need clean the cleading which front of the cooler.If the machine has the air–condition,it need clean the condenser.



Warning:It is dangerous when the compress air、 the high-pressure water、 the steam hit the body.It must use the glasses、 the veil and so on

Caution:Avoid shatter the vane of the radiator,the distance should exceed 500mm between the nozzle of the high-pressure water or the compress air and the surface of the radiator(water tank).The vane of the radiator which destroyed lead leak water or overheat.It need Check the radiator everyday when the pace has much dust.

4.Replace the coolant

After work 50hours,the first time to replace it.Then it need replace it two times in one year, Spring and Autumn.

1)Take down the cover of the radiator(water tank),open the vent valve to make the coolant out.

2)Clean the cooling loop,close the vent valve. Immit the coolant,then start the engine to make the engine run about 10 minutes with the low–speed.Then stop the machine and blow off the coolant.

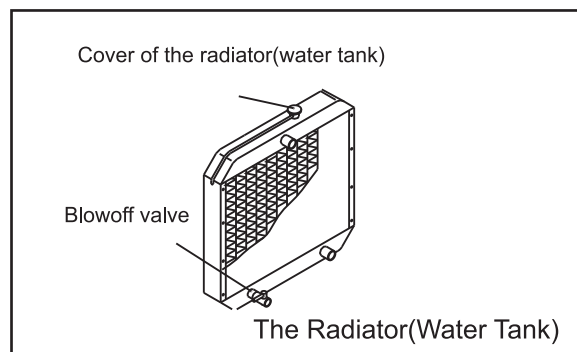

3)Close the vent valve again

4)Immit the coolant,let the engine run several minutes with the low-speed to make the coolant permeated the loop.

5)Check the level of the coolant and supply the coolant.



Warning:Don't open the cover of the radiator(water tank) with the hot engine except the temperature of the coolant under 50°C.

5.Check the consistency of the coolant

It need to Check the consistency of the coolant before the beginning of the cold weather.The coolant can use under 20°C.If the temperature of the condition lower,it should increase the proportion of the coolant.



Warning:The coolant is the toxicant.Avoid the children and the pet touch the coolant.If the coolant doesn't used,it need deal it as the rule.



Warning:It must use the coolant in any weather.

No use the water instead of the coolant.

The water from the river includes much autunite and other impurity.If it use this water,it will become the scale and adhesive to the radiator or the pipe of the cooling water.No use the drinking-water,too.

The coolant is easy to burn.No close the fire.

If the coolant into the eye,it should use the water to clean and to the hospital in time.

Lubricating System of the Engine

Maintenance manual

Capacity of the radiator-----5L

Check the level of the oil-----Everyday or 10h

Replace the oil or replace the filter core-----Everyday 250 hour

1.Check the oil level

Check the level of the oil before start the new machine.Then Check it every 10 hours.

1)Place the digger to the level road,and stop the engine.

2)Open the cover of the engine,take out the staff guage of the machine oil.Observe the value which has the oil.The level of the oil should lie in the value between the lowest(L) and the highest(H).

3)It can immit the oil through the sprue to make the level of the oil arrive the ordain value.

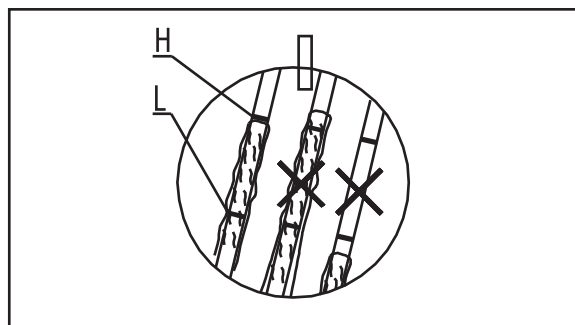

Warning:After stop the engine,the parts and the oil are the high-temperature.They will hurt the body.It need wait the temperature reduce when it start to maintenance.

2.Replace the engine oil

Replace the engine oil of the engine after start the new machine 50hours.Then replace it every 250 hours

1)Place the digger to the level road,and stop the engine,and remove the machine oil.

2)Take-down the vent bolt to make all the machine oil removed.

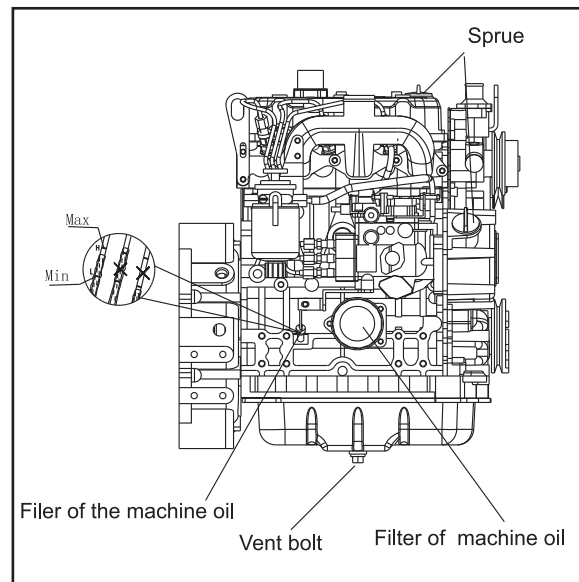

Warning:Avoid inhale the oil steam、 eat or touch the engine oil long time

3)Clean the vent bolt and install,if the seal ring has broken,it need replace it.

4)Open the sprue.

5)Immit the new machine oil till the oil arrive the “Max” of the oil leveler

6)Close the cover of the sprue,and run the engine about 5 minutes.

7)After stop the engine about 10–20 minutes,check the level of the machine oil. It immits the machine oil if it necessary.

3.Replace the filer core which for the engine oil of the engine

The first cleaning after the new machine runs 50 hours.Then clean or replace it every 250 hours.

Replace the filter of the engine oil

1)Clean the area which around the base of the filter,take-down the filter of the machine oil,clean the surface of the base.

2)Lubricate two seal gaskets which lie in the right of the filter

3)Before install the filter,it need wipe the machine oil on the surface of the seal gasket.

4)Install the filter as the manufacturer's request

5)Run the engine with the low-speed,check whether the filter leaks the oil

6)Stop the engine and wait 15 minutes to make the engine oil return

7)Check the level of the oil.Immit the machine oil to the"H" sign if it necessary.

Air Intake System of The Engine

Maintenance manual

Cleaning period of the dust tank-----Every 10hours or everyday

Replace period of the filer core-----Every 500h

1.Clean the dust tank

Clean the dust tank every 10 hours or everyday.

- 1)Take out the dust tank
- 2)Clean the dust tank

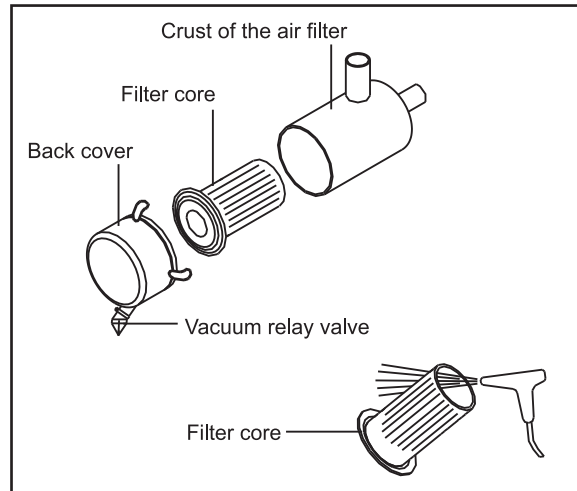

Warning: The dust will enter the engine if it checked, cleaned or replaced when the engine running and destroy the engine. Stop the engine before do the operations. It is dangerous when it use the compressor and the dust fly out. It need wear the glasses, the veil and so on.

2.Replace the filter core

It need replace when the core cleaned exceed 6 times or used 500hours.

- 1)Open the cover of the engine, take-down the back cover of the air filter, take down the core.
- 2)Install the new core, and close the cover

3.Check the air intake pipe

Check whether it has the things which the intake pipe has the fray, the pipe destroy, the clip loose or the pipe break and so on

Replace the pipe and the clip if it necessary, to make sure the intake system not leak.

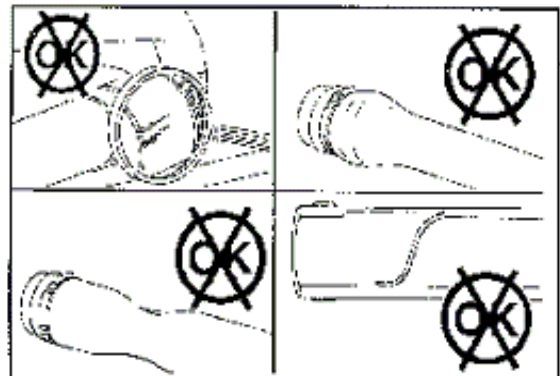

Other Maintenances of The Engine



Warning:No maintenance when the engine runs.If it must do the maintenance before the engine runs,it need have more than two persons to operate and operate as follow:

Must have one person sit on the operator's seat and prepare to stop the engine at any moment.And all the persons must keep in touch.

It maybe has the danger-winded when it near the fan、 the belt of the fan and so on to operate.

No insert the tools or other things into the fan or the belt of the fan.Otherwise,the part ruptured or fly out



Warning:It has the audition problem with temporary oreverduring if the machine has the noise too big.It need wear the earplug when do the maintenance and in the noise long time.

● Check the belt of the fan'tension

After 50 hours do the first checking.Then check it every 100hours.

It must use the right tension of the belt to assure the engine working and the belt's use life

About the right tension of the belt, between the belt wheel of the fan and belt wheel of the engine, it throw 110N to the belt by upright, the sinkage of the belt about 10mm or the deflexion of the belt wheel's center exceed the thickness

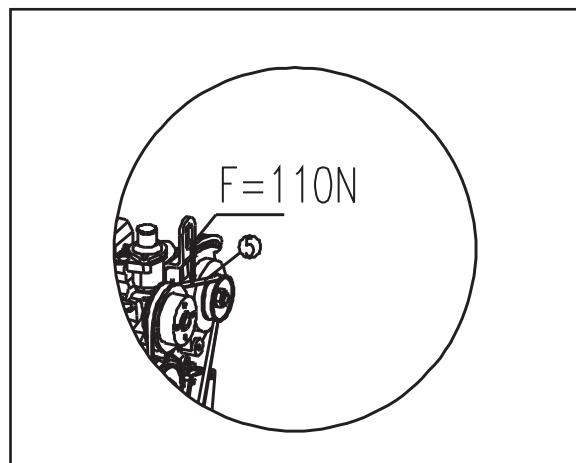

- Please see the attachment— 《User Manual for The Diesel Engine》 for the maintenance period of the other element and the ways

Hydraulic System

Maintenance manual

Capacity of the hydraulic oil tank-----	40L
Check the level of the oil-----	10h
Replace the filter-----	500h
Replace the hydraulic oil-----	1000h
Check the pressure system-----	500h



warning:It brings the serious hurt and death if the hydraulic oil or the axunge rip into the skin.Avoid your hand or body close the leaking area.It should use the paper to check it.



Warning:For avoid hurt,it does the maintenance only after the hydraulic oil cool or before working everyday.When Take-down the flange cover of the sprue,it nend turn the cover slow and release the pressure to avoid the oil spurt out.

1.Check the level of the oil of hydraulic pressure tank

Check it every 10 hours.

- 1)Stop the machine on the road.
- 2)Start the engine and make the oil tanks reciprocation moving
- 3)Draw back the oil tank of the level,throw out the oil tank of the bucket,then down the bucket.Lie the bulldozer to the ground, then stop.See the picture.
- 4)Observe the level of the oil thought the oil leveler of the hydraulic oil tank(see ①)
It requests the level can see in the area of the oil gauge.No fiuing too more to see the oil gauge.

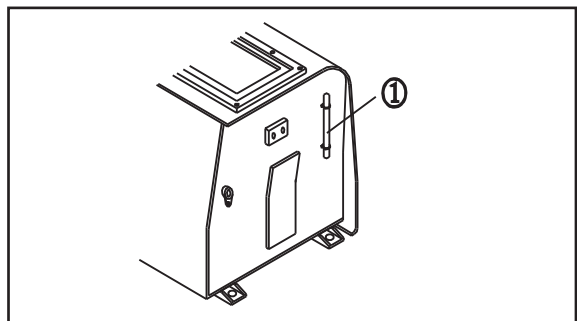
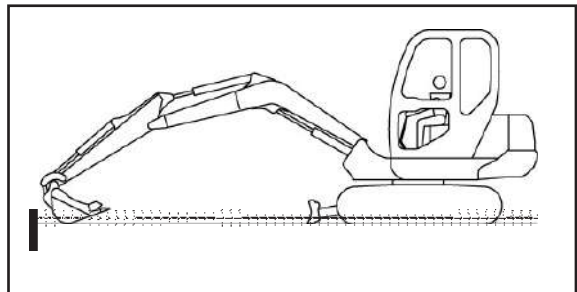

Caution:The level of the hydraulic oil will change when the temperature up.Before operate,the level lie the middle of the oil leveler,and when the temperature up,the level will arrive the top of the oil leveler.

2.Vent the water and the dust of the oil tank

Vent the water and the dust of the oil tank every 250hours.

- 1)Vent the air of the oil tank after stop the machine and the temperature down or before start the machine everyday.
- 2)Loosen the oil drain valve which lie in the bottom of the oil tank or the oil drain cock(see the picture)
- 3)Vent the water or the dust till the limpid hydraulic oil.Close the oil drain valve or screw down the bolt.
- 4)If the oil lacks,it should supply it.

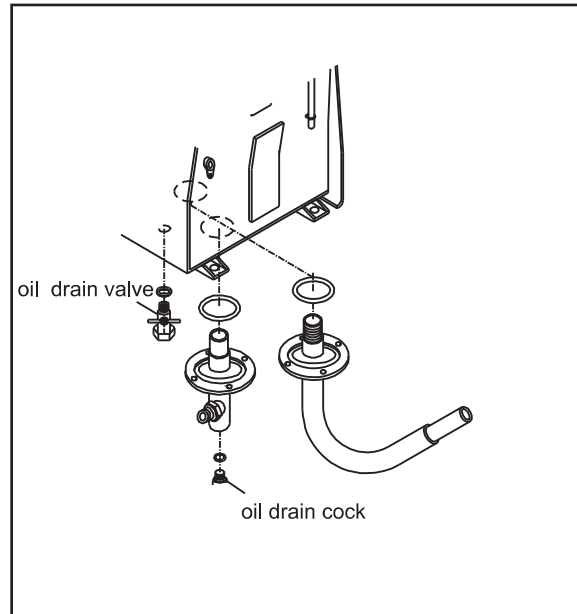

3.Replace the hydraulic oil and clean the filter

Replace and clean it every 1000 hours.



Warning:1)Avoid the scald,it vents the oil only after the hydraulic oil cool or before start the machine everyday.

2) When Take-down the flange cover of the sprue,it nend turn the cover slow and release the pressure to avoid the oil spurt out.

3)No allow the water、the dust、the soil into the oil tank when it replaces the oil.

Steps for replace the oil:

- 1)Stop the digger to the level road
- 2)Loosen the nut of the oil tank cover assembly (see ①).Open the flange and the air filter(see ②) together, don't drop the filter of the oil return.
- 3)Prepare a container which the capacity is 60L. the pump for take out the oil or the clean pipe to draw out the hydraulic oil

4) Same as the way which vent the water and the dust, loose the oil drain valve of the oil tank or the oil drain cock to vent the surplusage

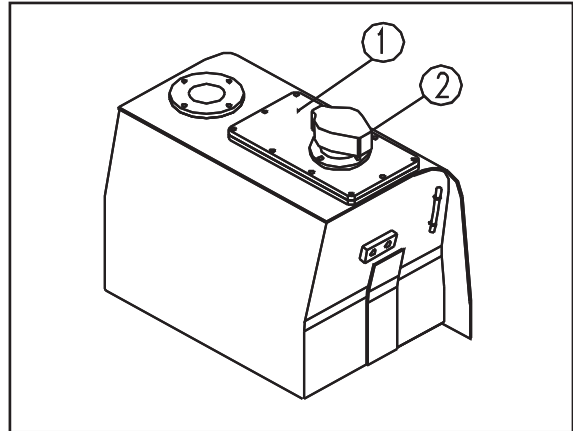

5). Take down the oil absorbent filter (see ③)

6) Clean the inside of the oil tank

7) Clean the vent cock and the vent valve, install it again.

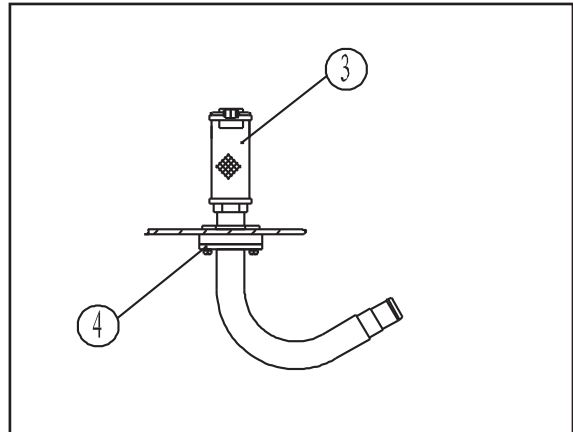

8) Clean the oil absorbent filter. Take out the oil absorbent filter ③ from the sprue (No let the dust drop into the inside of the oil tank). Take-down the parts of the filter, clear the impurity of the inside, and clean the parts with the diesel oil, then install it again.

9) Install the oil absorbent filter into the flange (see ④), then immit the new oil which as the hydraulic oil choose request and the Cleanness not exceed NAS6 grade, arrive the view area of the oil leveler. Cover the cover assembly and screw sown the nut last.

4. Vent the air which in the hydraulic system

A. Vent the air which in the pump

1) Loose the drain bolt of the vent, and check whether it has the oil out. Over the exhaust.

2) Over the exhaust, screw down the bolt.

Caution: If it run the pump without the oil, the pump will have the high temperature and make the pump break prematurely.

B.Vent the air which between the pump and the hydraulic oil tank

- 1)Start the engine,and keep it run with the mid–speed
- 2)Operate the operation device slow about 5 minutes to vent the air

Caution: If the engine runs with the high speed if it didn't vent the air which between the pump and the hydraulic oil, the pump also has the high-temperature

C.Vent the air which in the oil tank

- 1)Under the engine runs with the low–speed, draw/throw out the oil tank to the part 4–5 times which the end of the driving about 100mm(It mustn't draw/throw out to the end)
- 2)Then operate the oil tank to stroke end for 3–4 times
- 3)Last, operate the oil tank to stroke end for 4–5 times, and vent the air

Caution: If starts the machine and runs the engine with high-speed at once or the operate the oil tank to the end of the driving, the air which in the oil tank can destroy the piston airproof, and destroy the oil tank.

D.Vent the air which in the rotating motor(when it vent the oil from the shell of the rotating motor)

Caution :No rotating the machine at any time during vent the air

- 1)Run the engine with low–speed, loosen the blowoff cock, examine whether the oil outflow from the drain bolt
- 2)If it doesn't have the oil outflow, take–down the drain bolt, then immit the hydraulic oil into the crust of the motor
- 3)After vent the air, screw down the drain bolt
- 4)Last runs the engine with the low–speed, and turn the frame of the machine to left/right about two times.

Caution: If it doesn't vent the air which in the motor, it maybe destroy the bearing of the rotating motor.

E.Vent the air which in the driving motor(when it vent the oil from the shell of the driving motor)

1)Run the engine with low–speed, loose the blowoff cock. If the right oil outflow, screw the bolt.

2)Run the engine with low–speed, make the operation device rotating 90° ,and let it lie in one side of the pedrail.(See the picture)

3)Use the operation device uplift the machie, make one side of the pedrail away the ground litter, and run the pedrail 2 minute. Repeat do for the left/right pedrial, and turn the pedrail forwards and backwards

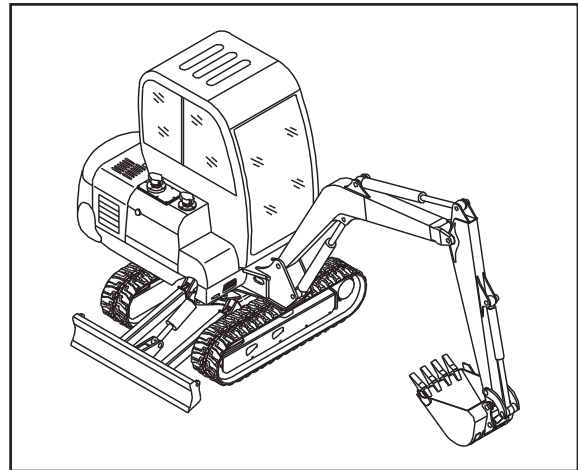

F.Vent the air which in the attachment

If the machine has the attachment, it need run the engine with low–speed, and operate the footplate of the attachment(about 10 times),till the air vented from the pipe laying of the attachment.

Caution:

- 1.If the manufacturer has the way for vent the air,it should do it as the way**
- 2.After finish the operation, stop the engine. It need lay up the machine 5 minutes before start the operation to clear the air bubble of the oil tank**
- 3.It shouldn't leak when checking. Wipe the oil which spill over.**
- 4.After the operation, check the level of the oil. If the level of the oil is low, it need supply it.**

5. Replace the filter core of the oil return

Replace it every 500 hours. The filter of the oil return in the hydraulic oil tank, so:

- 1) Take-down the cover of the flange ② with the air filter ① together.
- 2) Take down the "O" seal ring ③ of the flange cover
- 3) Take down the spring ④
- 4) Take down the filter element ⑨ from the flange of the oil return ⑩
- 5) Screw down the core ⑦ from the lever ⑥
- 6) Replace "O" ring ⑧ of the core, after it install with the lever ⑥, wipe the hydraulic oil to "O" ring, then insert the nozzle of the flange ⑩
- 7) Install the spring ④ on the top of the lever ⑤
- 8) Adjust the base of the spring, make the gap which the base of the spring with the cover of the flange ② not exceed 10mm, and use the nut which under it lock and fix
- 9) Install the "O" seal ring ③
- 10) Install the cover of the flange ②. Press the convexity into the hole which in the top of the lever ⑤, screw down the nut

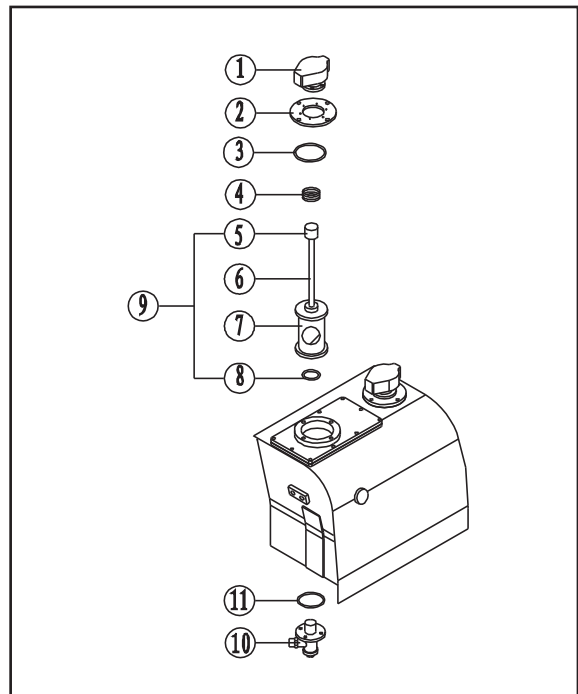

6. Replace the filter core of the guide pipe laying

Replace it every 500 hours.

Caution: It must vent the pressure of the hydraulic oil tank before take-down the filter core

- 1) Screw down the filter shell ⑤
- 2) Take-down the filter core ③
- 3) Install the new "O" ring ② into the groove of the filter head

- 4) Before install the new core, it need wipe the hydraulic oil on the surface of the sealer, and put the core into the filter head
- 5) Clean the filter shell ⑤ and soft magnet. No allow the dust and the water into the filter shell.
- 6) Screw down the filter shell and the filter head with the moment 25–35Nm
- 7) Connect the pipeline, and start the engine slow. And run 3–5 minutes vent the air
- 8) Place the machine on the level road, stop and check the level of the oil. It can supply the oil if it necessary. No let the oil over the highest limit

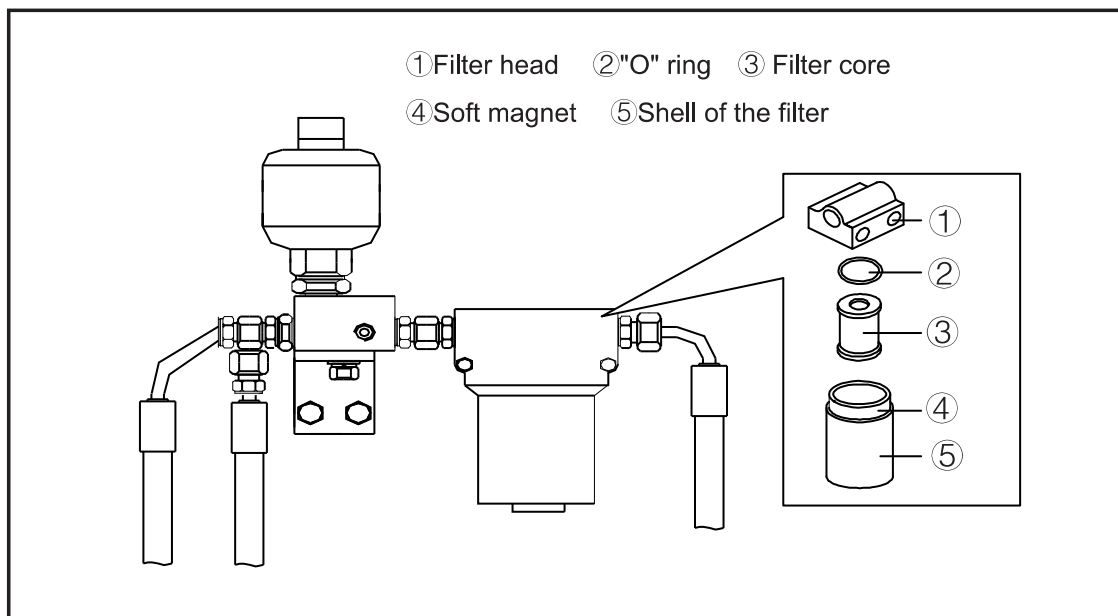

■ The replace period of the hydraulic oil and the filter core when it the attachment (Crush hammer, ect.)

It increase the pollution of the hydraulic system when use the hydraulic hammer. The replace period of the hydraulic oil and the filter core reduces, too. Avoid destroy the hydraulic pump and other hydraulic elements, it suggest the periods as follow: (Unit: Hour)

Working rate of the hydraulic hammer	Replace period of the hydraulic oil	Replace period of the filter core
50%	1000	300
100%	500	300

Caution: It adjust the pressure of the system as the hydraulic hammer's request when use the hydraulic hammer.

Air-condition(optional)

The main makeup of the air-condition as the following picture. The operation switch in the plane of the control box.

About the operation and the maintenance of the air-condition, please see the user manual and the air-condition user manual.

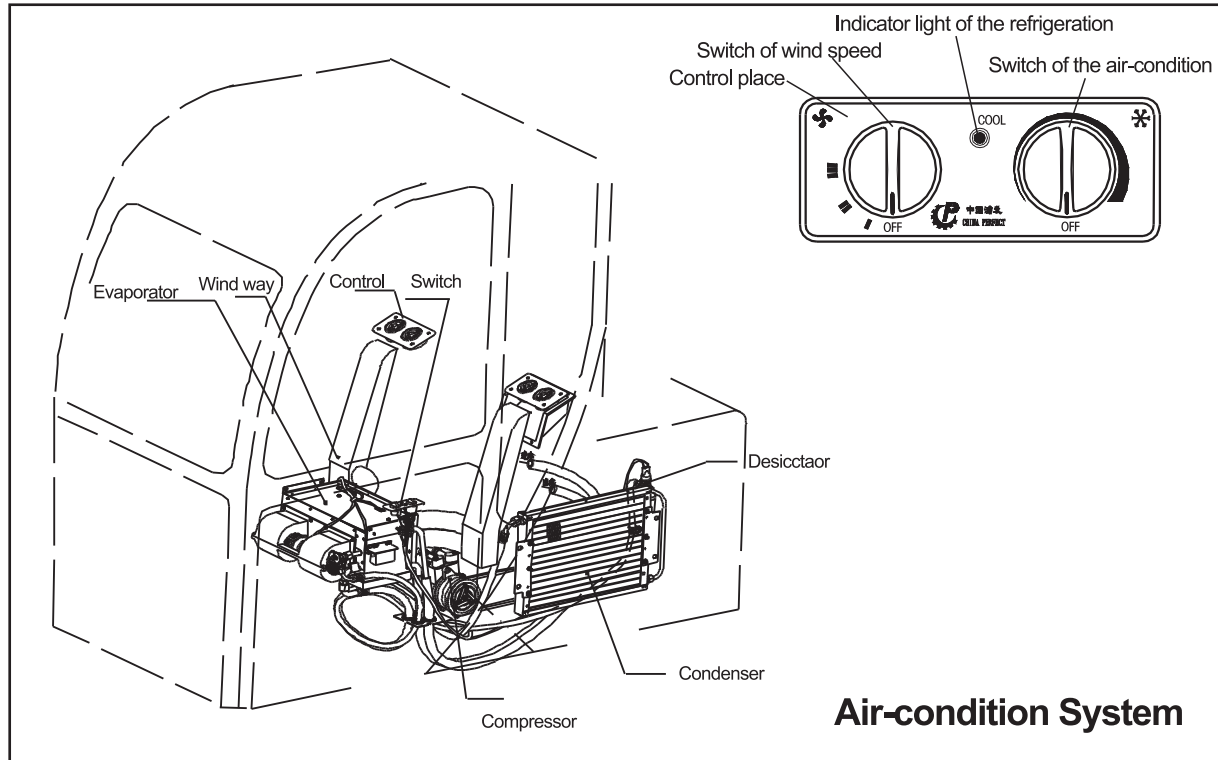

1. Caution items of the air-condition maintenance

- 1) If the air-condition assembly has the dust screen. The dust screen must be cleaned often. Otherwise, the dust will stop the dust screen and make the air not thought the heat exchanger.
- 2) It should close the water warming valve, when it uses the refrigeration system in summer and use the draft system in spring and autumn. When it uses the warming-up system, it should open the water warming and turn the air-condition's switch to "OFF".
- 3) The core of the caliduct connects to the water tank of the engine, if the core leaks, it will lead the water of the water tank to lack, and make the engine overheat. In winter, it is the same to protect the core from freezing as the water tank. Avoid the coolant from freezing to make the core or the water tank freeze, please use the coolant which the manufacture requests, which produce the main machine. Please let out the coolant if the machine stops long time in winter when it may freeze.
- 4) Please run the thermantidote every 15 days if it doesn't use it long time. And run about 5-10 minutes every time.

2. Check the value of the refrigeration



The refrigerating agent is easy to frostbite the skin. And it emit the poisonous gas and light when the refrigerating agent near the fire. It need make sure the refrigerating agent no spray to the skin and the eyes when it need to take-down the refrigeration system. It should let it out then take-down it. No fire.

If the machine short of the refrigeration agent, the cooling performance will worse. Check the value every month or every 250 hours. According the view mirror of the desiccator whether has the air bubble to judge the value when the engine runs high-speed and the air-condition stay the refrigeration state.

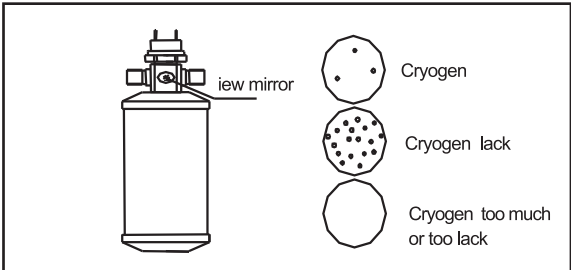

3. Check、 adjust the belt tension of the compressor

Check it every 250hours

A. Check

Use the finger about 12N power to press the middle part which between the drive belt wheel and the compressor belt wheel and check the deflexion about 5-7 mm

Check whether the belt destroy .It need to replace when the belt pulled ,no adjust value or the belt has the rift.

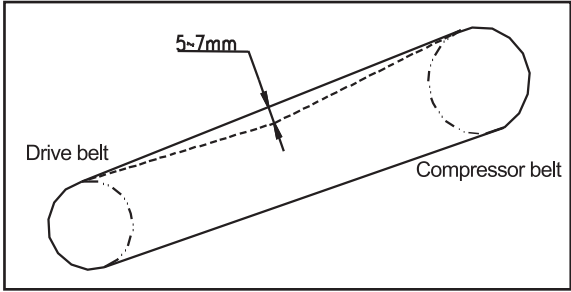

B.Adjust

Loose the bolt(see the picture),use the tommy bar to open the compressor, adjust the belt to the suitable tension. And screw down the bolt.(If it necessary,it can loose the two bolts which for fix the compressor)

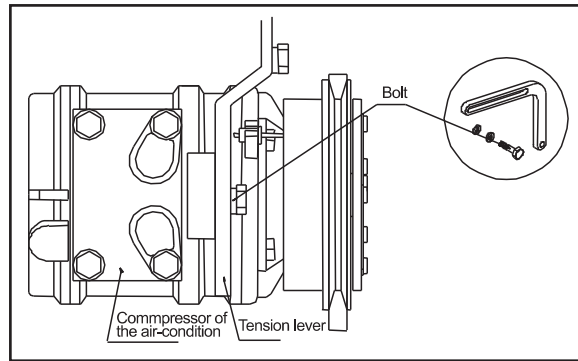

4、 Items of the time-ckeck

No.	Check Item	Check Content	Check Periods	
			Every Month	Every Quarter
1	Fastener	If loose、 fall off	★	
2	Belt of air-condition	The tension and fray	★	
3	Pipeline	If fray or rupture	★	
4	Tie-in	If fray of leak		★
5	Electric fan	Whether run normal	★	
6	Line	If fray、 burn	★	
7	Condensator	If has the dust stop		★
8	Electromagnetism clutch	If slip	★	
9	Compressor	If has the noise		★
10	Value of refrigeration agent	If the view mirror has the air bubble	★	
11	dust screen	If stop	★	

Replace The Teeth of The Bucket

It replaces the gear of the bucket before the base of the gear fray.



Warning:If the operation device because of the wrong operation and lead it moving,it very dangerous when replace the gear. Before replace the gear,it should make the operation device locked,then stop the engine and let all the joy stick locked.It need use the guard to avoid the axes out.

Replace the gear

1)Make the base device of the bucket on the stow-wood for take-down the axes. Check whether the operation device stay the tranquilization state and the bucker place level.Then push up the safety lock of the left control box,then stop the engine.

2)Put the metal stick which the diameter smaller than the axes on the axes'head,use the hammer knock the stick to knock out the axes,and take-down the gear.

3)Clean the installing surface.Install the new gear into the base of the gear,use the hand push the axes into it,then use the hammer knock the axes into the lock to make the gear into the base of the gear.

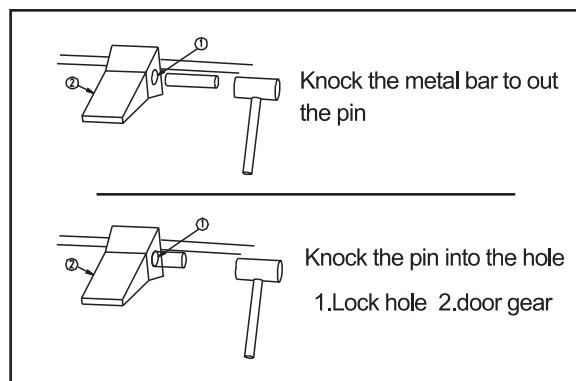
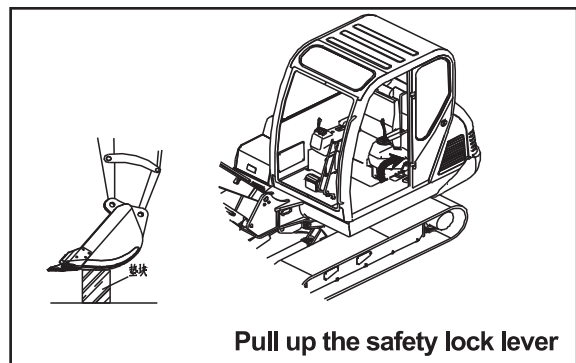

Washing The Plastic Mat of the floor

Avoid the floor slip、tumble to make the accident,please wash it at any moment if it dirty.



Warning:If it touches the joy stick unguarded,the operation device or the machine will move,and lead the accident.

So it must place the machine on the hard and smooth road before take down the plastic cushion.It must uplift the guide safety handle and the top control box to lock the guide system before the operator leave the seat.

The step for washing the plastic mat:

- 1)Take the plastic cushion out the cab
- 2)Use the brush to washing the dunghill or use the water washing it.
- 3)Use the clean mop to clean the floor
- 4)After the plastic cushion dry take back.

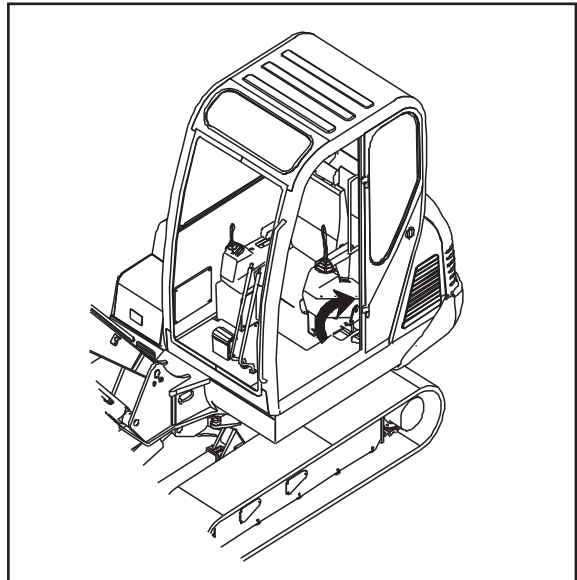

7. Check the pressure of the system

Check it every 500 hours

1) It adjusts and checks the pressure after the temperature of the hydraulic oil arrives 50°C

2) Use the manometer with the flexible pipe. The measurement of the manometer is 0–30Mpa.

3) Connect the manometer with the direct head, M10 × 1 to the piston pump (see the picture ①②)

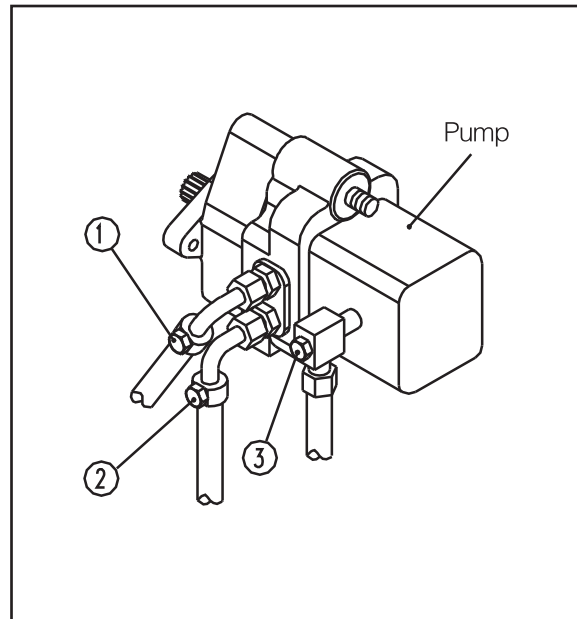

4) Test the pressure adjust value of the safety valve. The value is 21Mpa+/-0.2Mpa. If the value doesn't arrive the request, it needs to adjust the main safety valve of the main safety adjust multi-valve which in the adjust multi-valve, till the value arrives the ordain value.

Test the pilot pressure:

1) Unscrew the bolt of outlet-in which for the supply valve of the pilot oil (see the picture: the accumulator ①), connect the manometer with the direct head and M10 × 1. The measurement of the manometer is 0–6Mpa.

2) Check the pressure value of the guide oil. The value is 3 Mpa+/-0.5Mpa. If the value doesn't arrive the request, it needs to adjust the safety valve of the oil valve till arrive the value.

Caution: Please contact the service agent when the pressure of the main circuit, the bulldozer circuit and the pilot oil circuit can not reach the request.

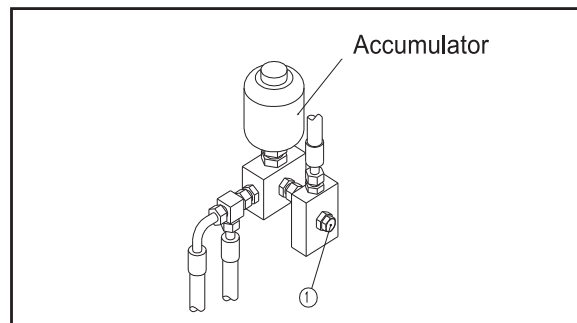

The Reducer

Maintenance manual

Lube capacity of the rotating reducer	-----1.6L
Lube capacity of the driving reducer	-----2.5L(each side)
Check the level of the lube and append the oil	-----250h
Replace the lube	-----1000h
Check the tighten moment for the connect bolt of the reducer	-----500h

1.Check the level of the lube for the driving reducer and put on steam



Warning:The oil of the reducer will heat when the machine drives.The driving reducer and the oil in the high-temperature after stop the engine.It will make scald.

It must wait the oil cool before start.Loose the vent bolt two or three,it can take-down the bolt after release the air pressure.It is dangerous to take-down the bolt fast.

Check it every 250hours

- 1)Prepare a inside hexagon spanner.
- 2)Stop the digger on the level road.
- 3)Turn the driving reducer make the two bolt of the outboard in "a" position(see the picture), then stop the machine
- 4)After the oil cooling,open the bolt①
- 5)After release the air pressure, screw down the bolt①
- 6)Open the bolt②,check the position of the level.The height of the level should arrive the bottom of the bolt hole.
- 7)It can supply the machine oil if it necessary (as the way to append the oil)
- 8)Clean the bolt②,install to the reducer again.
The tighten moment is 12–15Nm.

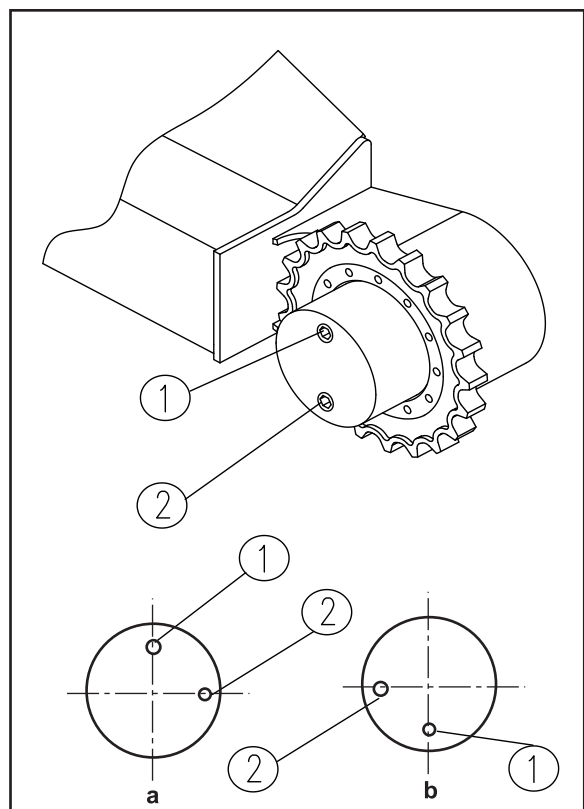

2. Replace the lube (For each reducer)

Replace it every 1000 hours

- 1) Stop the digger on the level road.
- 2) Turn the driving reducer make the bolt ① in "b" position (see the picture)
- 3) Vent the oil when the oil of the reducer is in the hot state.

Caution: Don't let the hot oil scald

- 4) Loosen the bolt ① and vent the oil, and loosen the bolt ② to make vent the oil complete
- 5) Turn the driving reducer make the bolt in "a" position
- 6) Append the oration lube through the sprue till the check hole ② of the level has the oil out.
- 7) Screw down ① and ②, the tighten moment is 12–15 Nm.

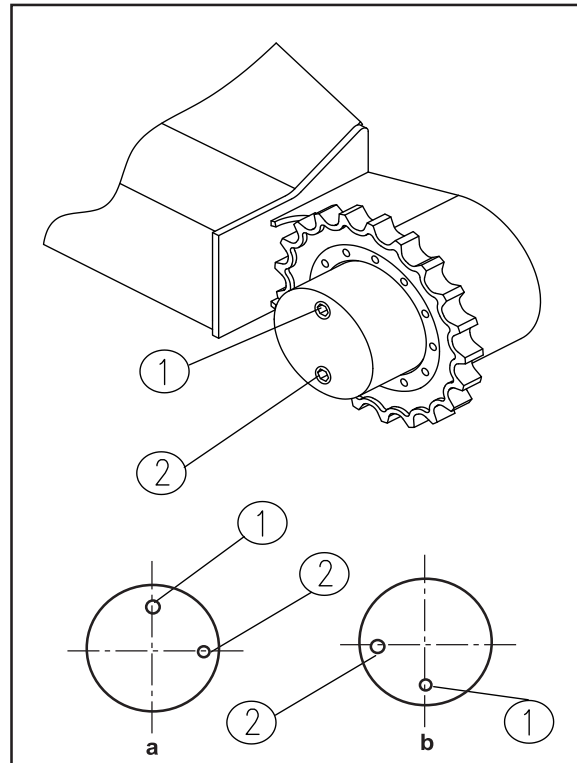

3. Check the tighten moment for the driving reducer with the connect bolt of the rotating reducer

A. Fixing check for the connect bolt of the driving reducer

After runs 50 hours check it the first time. Then check it every 500 hours.

The tighten moment is 150 ± 10 Nm for the bolt which connect the reducer, the base and the drive wheel.

B. Fixing check for the connect bolt of the rotating reducer

After 50 hours check it the first time. Then check it every 500 hours.

The tighten moment is 195–250 Nm for the reducer and the bolt of the platform.

Support Roller, Carrier Roller & Leading Roller

1. Check the tighten moment of the support roll

After 50 hours check it the first time. Then check it every 500 hours.

The tighter moment of the bolt ② is 195 ± 15 Nm

If it finds the bolt looses, it need screw it down and clean the thread additive which for lock and fix of the bolt. And wipe the additive again, then screw down it with the tighten moment which requested.

If it need to replace the bolt, it must use the same bolt.

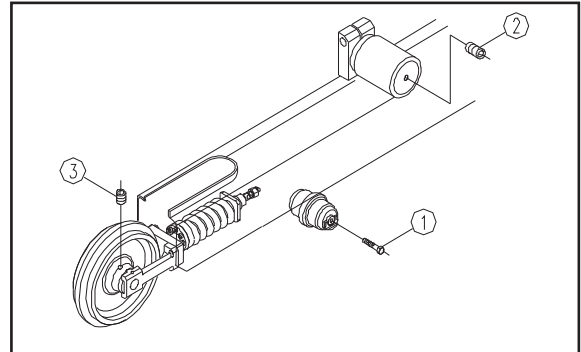

1. Bolt of the support roller

2. Carried roller cock

3. Guide roller cock

2. Check the level of the machine oil for the carrier roller and leading roller

Check it every 1000 hours.

1) Take out the nut ②、③ of the carrier roller and leading roller

2) Immit the oil

3) When the sprue has the oil out, screw down the nut ②、③ again.

Check and adjust the tension state of the crawler

B. Steel Crawler

Check it every 10 hours.

- 1) Place the digger on the smooth and hared road..
- 2) Adjust the tension of the crawler to make the A which between the middle part of the support roll, and the deflexion is 10–15mm(a of the picture 1)
- 3) Take down each cover of the crawler frame(b of the picture 1), show up the sprue of the tension device(① of the picture 2)
- 4) For loose the crawler, first loose the tie-in②(picture 2), to make the lube out till the tension screw down again.
- 5) For adjust the crawler, connect the tie-in of the butter gun and the tie-in②(picture 2). Then use the butter gun immit till the right tension.

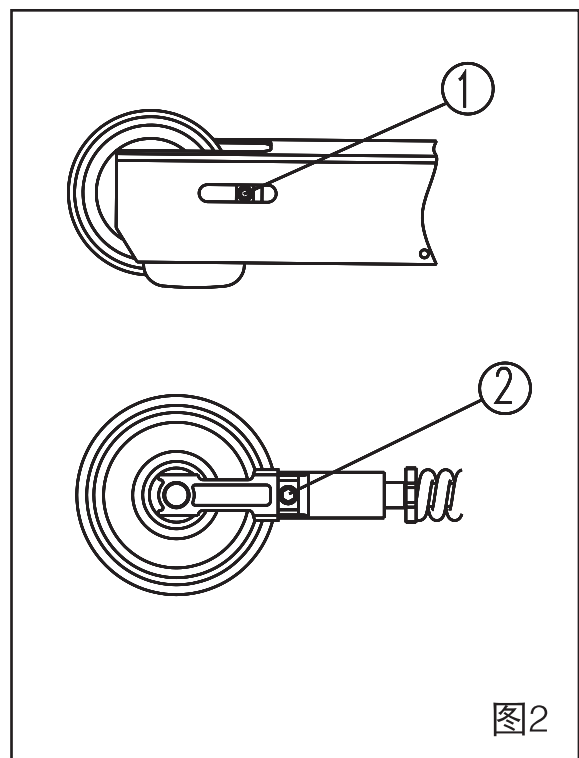
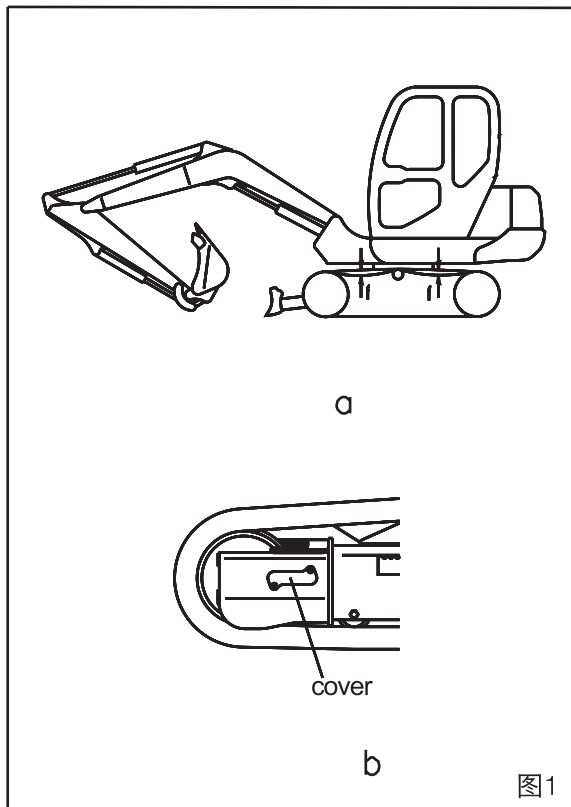

Warning:No knock the tension spring of the crawler. The spring will rupture when it bear the large pressure. And hurt the person. No take-down the spring when it in pull state.

Lubricating

Lubricating the parts which need in every 50 hours

Steps:

- 1) Start the working equipments and put the bucket on the ground
- 2) Put the bulldozer on the ground
- 3) Stop the engine
- 4) Clean the sprue of the oil cup
- 5) Lubricating the parts and wipe the excess lubricant

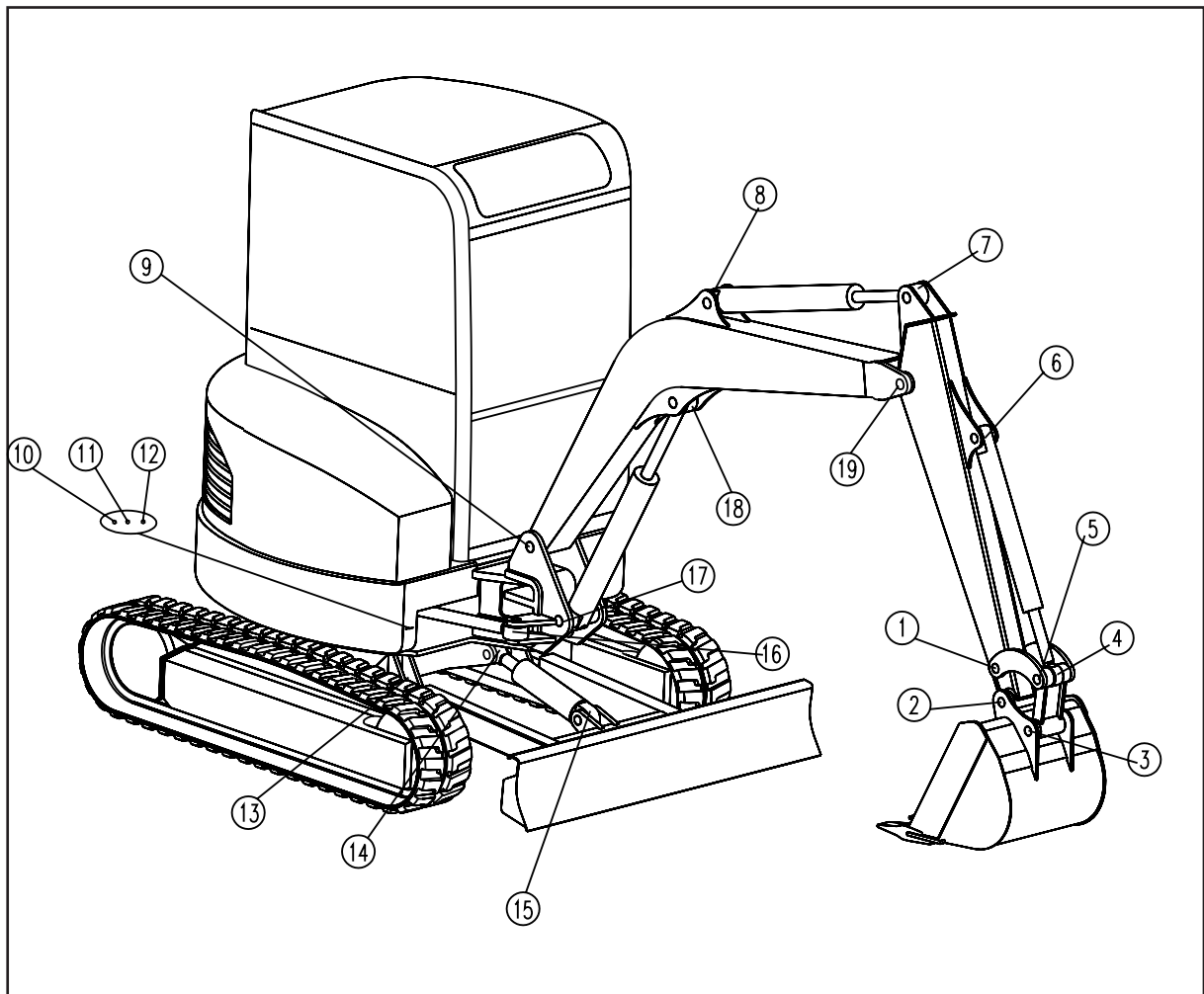

1. Panel point between arm and bucket
2. Panel point between arm and bucket
3. Panel point between connecting rod and bucket
4. Lubricating point between bucket cylinder head
5. Panel point between rocker and connecting rod
6. Lubricating point of bucket cylinder end
7. Lubricating point of arm cylinder head
8. Lubricating point of arm cylinder end
9. Panel point between boom and platform
10. Lubricating point of steering cylinder
11. Lubricating point of slewing support track
12. Lubricating point of slewing support gear
13. Panel point between dozer and chassis
14. Panel point of dozer cylinder head
15. Panel point of dozer cylinder end
16. Lubricating point of slewing cylinder
17. Lubricating point of boom cylinder end
18. Lubricating point of boom cylinder head
19. Panel point of between boom and arm

Air-condition(optional)

The main makeup of the air-condition as the following picture.The operation switch in the plane of the control box.

About the operation and the maintenance of the air-conditionation,please see the user manual and the air-condition user manual.

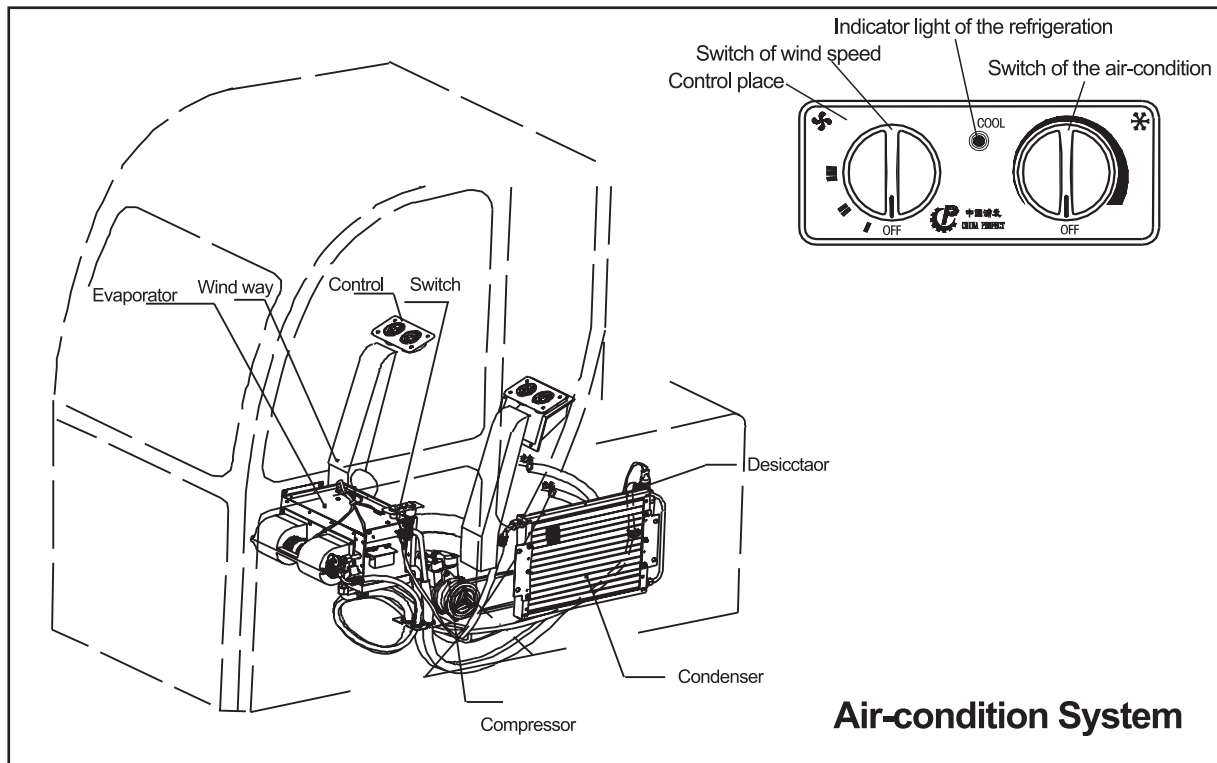

1.Caution items of the air-condition maintenance

- 1)If the air-condition assembly has the dust screen.The dust screen must cleaned often. Otherwist,the dust will stop the dust screen and make the air not thought the heat exchanger
- 2)It should close the water warming valve,when it uses the refrigeration system in summer and use the draft system in spring and autumn.When it use the warming-up system,it should open the water warming and turn the air-condition's switch to "OFF"
- 3)The core of the caliduct connect to the water tank of the engine,if the core leaks,it will lead the water of the water tank lack,and make the engine overheat.In winter,it same to protect core not freeze as the water tank. Avoid the coolant freezed to make the core or the water tank freeze,please use the coolant which the manufacture requests, which produce the main machine.Please let out the coolant if the machine stops long time in winter when it maybe freeze.
- 4)Please run the thermantidote every 15 days if it doesn't use it long time.And run about 5-10 minutes every time.

2. Check the value of the refrigeration



The refrigerating agent is easy to frostbite the skin. And it emit the poisonous gas and light when the refrigerating agent near the fire. It need make sure the refrigerating agent no spray to the skin and the eyes when it need to take-down the refrigeration system. It should let it out then take-down it. No fire.

If the machine short of the refrigeration agent, the cooling performance will worse. Check the value every month or every 250 hours. According the view mirror of the desiccator whether has the air bubble to judge the value when the engine runs high-speed and the air-condition stay the refrigeration state.

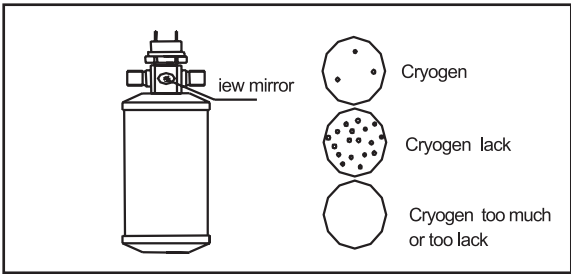

3. Check、 adjust the belt tension of the compressor

Check it every 250hours

A. Check

Use the finger about 12N power to press the middle part which between the drive belt wheel and the compressor belt wheel and check the deflexion about 5–7 mm. Check whether the belt destroy .It need to replace when the belt pulled ,no adjust value or the belt has the rift.

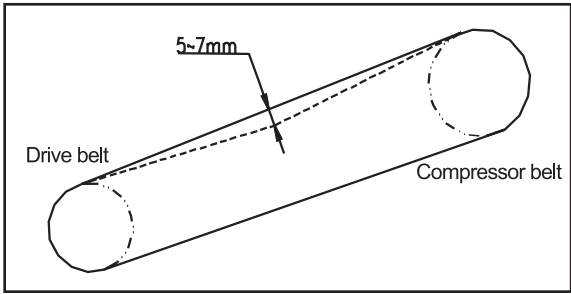

B.Adjust

Loose the bolt(see the picture),use the tommy bar to open the compressor, adjust the belt to the suitable tension. And screw down the bolt.(If it necessary,it can loose the two bolts which for fix the compressor)

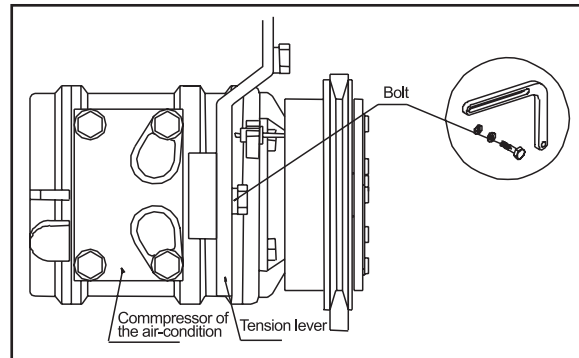

4、 Items of the time-ckeck

No.	Check Item	Check Content	Check Periods	
			Every Month	Every Quarter
1	Fastener	If loose、 fall off	★	
2	Belt of air-condition	The tension and fray	★	
3	Pipeline	If fray or rupture	★	
4	Tie-in	If fray of leak		★
5	Electric fan	Whether run normal	★	
6	Line	If fray、 burn	★	
7	Condensator	If has the dust stop		★
8	Electromagnetism clutch	If slip	★	
9	Compressor	If has the noise		★
10	Value of refrigeration agent	If the view mirror has the air bubble	★	
11	dust screen	If stop	★	

Replace The Teeth of The Bucket

It replaces the gear of the bucket before the base of the gear fray.



Warning: If the operation device because of the wrong operation and lead it moving, it very dangerous when replace the gear. Before replace the gear, it should make the operation device locked, then stop the engine and let all the joy stick locked. It need use the guard to avoid the axes out.

Replace the gear

1) Make the base device of the bucket on the stow-wood for take-down the axes. Check whether the operation device stay the tranquilization state and the bucket place level. Then push up the safety lock of the left control box, then stop the engine.

2) Put the metal stick which the diameter smaller than the axes on the axes' head, use the hammer knock the stick to knock out the axes, and take-down the gear.

3) Clean the installing surface. Install the new gear into the base of the gear, use the hand push the axes into it, then use the hammer knock the axes into the lock to make the gear into the base of the gear.

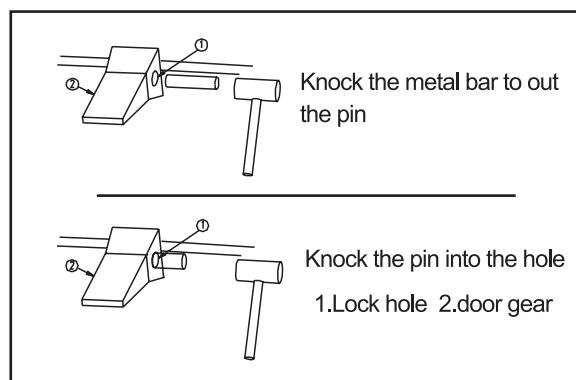
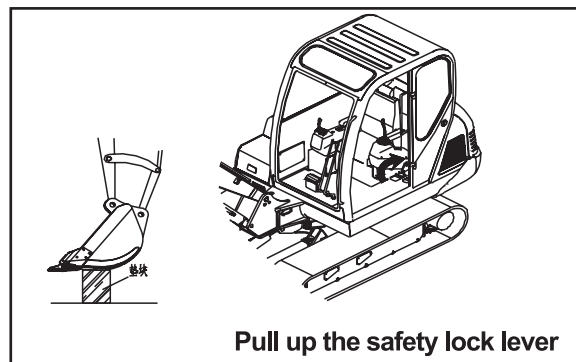

Washing The Plastic Mat of the floor

Avoid the floor slip、tumble to make the accident,please wash it at any moment if it dirty.



Warning:If it touches the joy stick unguarded,the operation device or the machine will move,and lead the accident.

So it must place the machine on the hard and smooth road before take down the plastic cushion.It must uplift the guide safety handle and the top control box to lock the guide system before the operator leave the seat.

The step for washing the plastic mat:

- 1)Take the plastic cushion out the cab
- 2)Use the brush to washing the dunghill or use the water washing it.
- 3)Use the clean mop to clean the floor
- 4)After the plastic cushion dry take back.

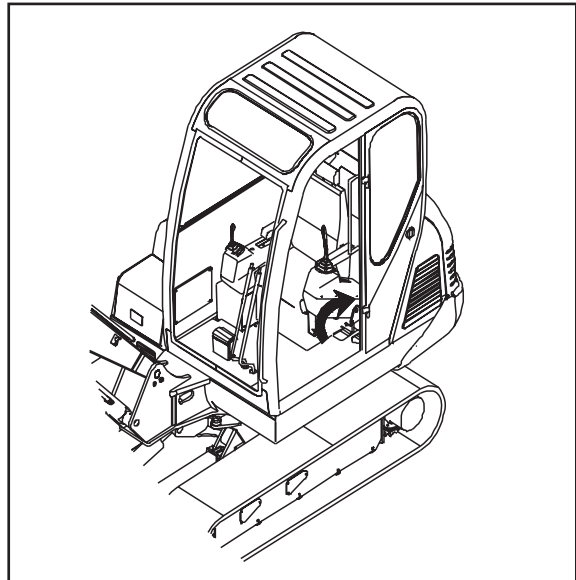

6

Attachment Manual

Safety Item

It will affect the service life of the machine and bring some safety problems, if the machine has been installed some attachment which not authorized by Yuchai. If it need install the attachment, it must contact Yuchai.

If you don't contact us,we haven't to bear any duty about the accident or damage.

1.The attachment of safe operate

- The attachment has the strong assistant function. It need to use the attachment with right way to avoid hurt or damage.
- Read the attachment user manual. Don't use the attachment before you don't know the content of the manual. If the user manual has been lost, please let the manufacturer or the attachment sale company supply new one.
- It need install the necessary foreside mantle that according to the circs of the attachment.
- The libration noise cause the colleague difficult communicates the operation purpose. It needs to seed a compere and fix on the signal before operating.
- Don't rotate the machine when the attachment has overload. It is very dangerous that doing this operation on the slop.
- The foreside of the operation device has overload and unstable when the machine has the hammer. For avoid dangerous overturn, don't operate the machine when the attachment turn to the side.
- The rotating area and the barycenter are different when the machine installs the attachment, the machine can move suddenness. It must realize the machine's instance.
- It need to set a warning line near the machine avoid the person enter before operated. Don't operate the machine when it has the person near it.
- Avoid the wrong operating that lead the accident, don't put the foot on the footplate except operate the footplate.

2.Take down or install the attachment

- Take down and install operation on the hard and smooth road
- Fix on the signal when it has two persons do the operation or above. And abide the signal
- It must use the chain block when upgrade or carry the heavy object(exceed 25kg)
- Need support the part when take down the heavy parts.Caution the barycenter when use the chain block
- It is dangerous to use the chain block for overload. It need have a plank to make sure the state safe
- Make sure the steady state that can not overturn when place the attachment which take down or install
- Don't walk under the chain block when it overload.



Warning: It needs the qualification certificate to operate the chain block. About the details of take-down and installation ,please contact Yuchai

The steps of the attachment Installing & take down

1.Steps for take-down

- 1)Put the attachment on the ground and stop the engine
- 2)Turn the start switch to “ON” and push the left control box to the free position
- 3)Turn the jot stick of the operation device to front、back、left、right and operate the attachment controlling footplate 2–3 times to release the pressure of the hydraulic pipe laying.
- 4)Lock the rotary valve which connect to the leading–in tube and outlet pipe of the lever'side after make sure the oil temperature down.
- 5)Take–down the soft pipe which in the side of the attachment, twist the combination gasket of the bulkhead cover to the leading–in tube and the outlet pipe.
- 6)Take down the attachment thought take–down the axes,then install the bucket.
- 7)Use the clean plastic bag to pack the end of the rubber pipe from the hydraulic hammer. Deposit the attachment

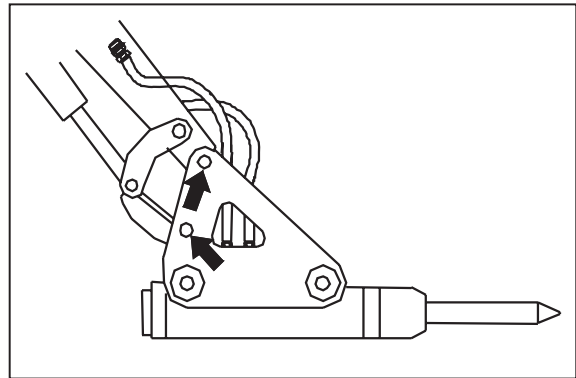

2.Steps for installing

- 1)Take down the bucket
- 2)Put the attachment to a smooth area,use the axes A and axes B connect the lever with the hydraulic and the connect lever with the hydraulic one by on
- 3)Take down the bolt from the leading–in tube and outlet pie after the oil temperature down.No let the dust、 soil touch the tie–in of the soft pipe.If the combination gasket destroy,replace the new one.
- 4)Connect the soft pipe of the attachment'side.Check the flux of the oil and no connect wrong when it connect
- 5)Unlock the rotary valve which connect to the leading–in tube and outlet pipe of the lever'side
- 6)After install the attachment,it need make sure the oil level of the hydraulic oil tank to the suitable position.

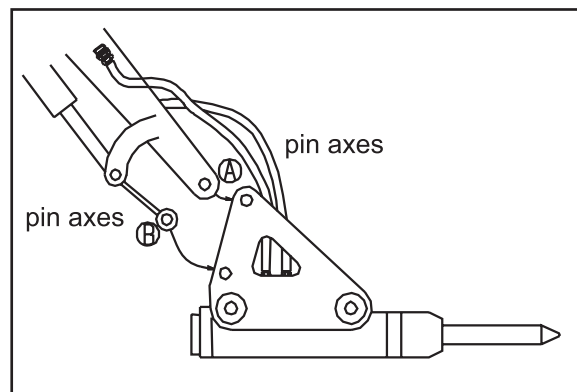

Operation Manual of the attachment

The parts introduce the caution when operate the digger which install the attachment.

Caution: Choose the attachment which is the best one of the main machine. The type of machine is different which can install the attachment. About the attachment and the type's choosing, please contact Yuchai.

Hydraulic crush hammer

1. User manual of the hydraulic crush hammer

The hydraulic crush hammer is the familiar attachment.

1) Make sure the direction of the hammer top plumb the surface of the object when the machine do the crush operation, and keep it at any moment. If it has the gradient with the surface of the object, the hammer maybe slips by itself. And will lead the hammer mangle and affect the piston. Please choose the best point to crush. And make sure the hammer steady then knock.

And make sure the hammer steady then knock.

Request to adjust the oil tank of the bucket to keep the penetrate direction of the hammer and the body of the hammer in on line.

2) Press the hammer to surface of the object, and make the underpan about 5cm from the ground. When inflict the wallop. No let the machine away the ground too much.

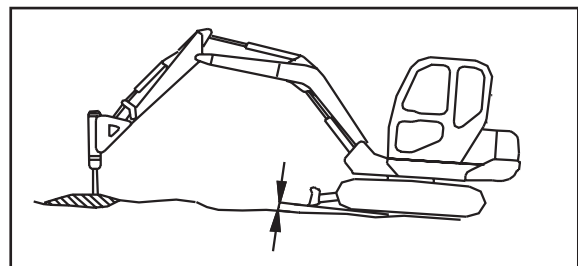
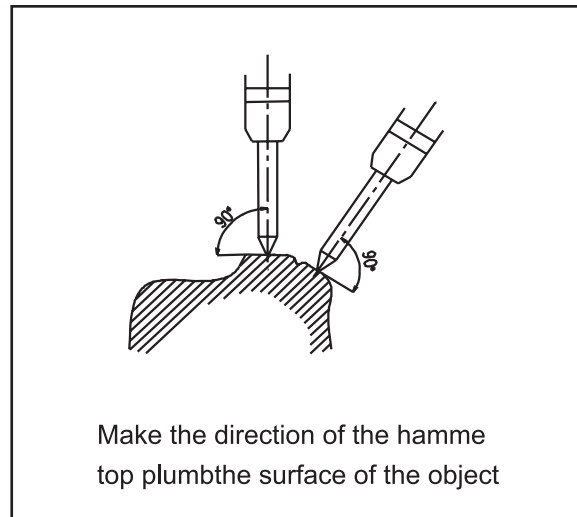

3)If the hammer doesn't penetrate or crush the surface within one minutes when inflict the wallop on one surface continuous,it need to change the impact part and near the edge of the object to crush.

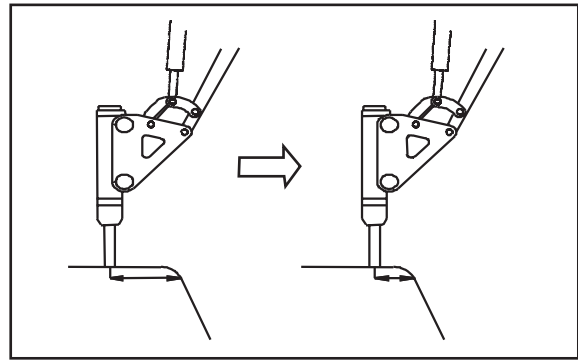

4)Use the hammer to impact the surface suitable,avoid no resistance use the wallop
Stop use the crush hammer to impact when the rock or the object crushed.If not stop,it will lead the bolt of the main body loose and mangle.

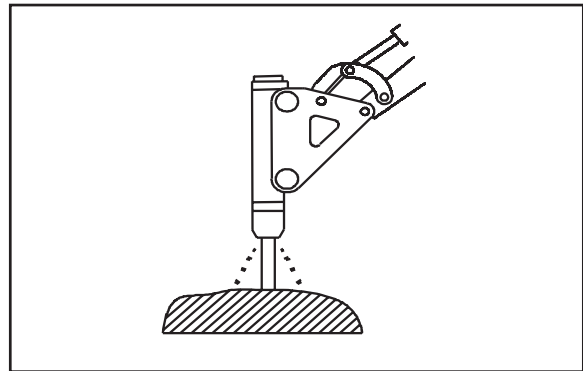

2.Operate tabu of the hydraulic crush hammer

For the machine has long use life and the safety operation,no operate as follow:

Caution:No operate the oil tank

to the end of the driving it should keep the rest about 5cm

1)Push the heavy thing or the big block use the crush hammer

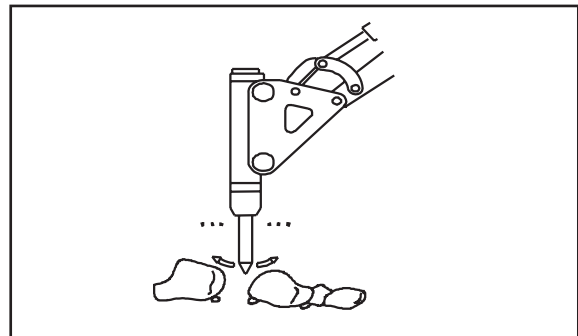

2)Use the rotating operation

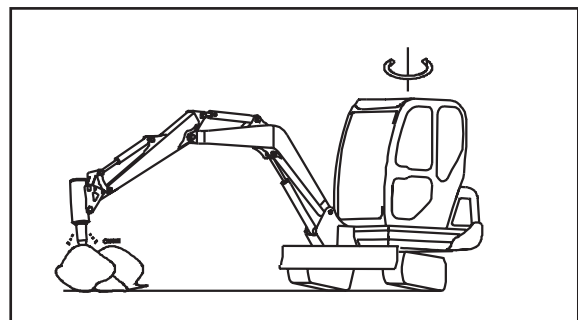

3) Move the hammer when do the impact operation

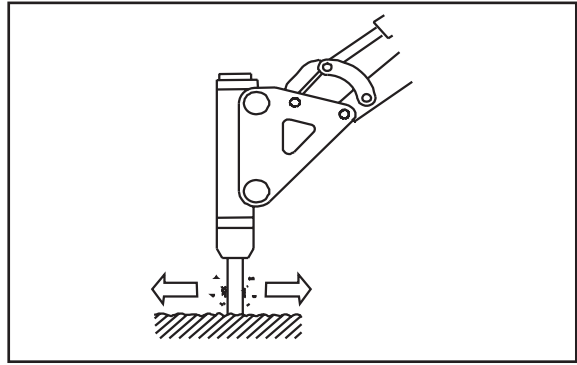

4) Inflict the wallop on the level ground or upwards

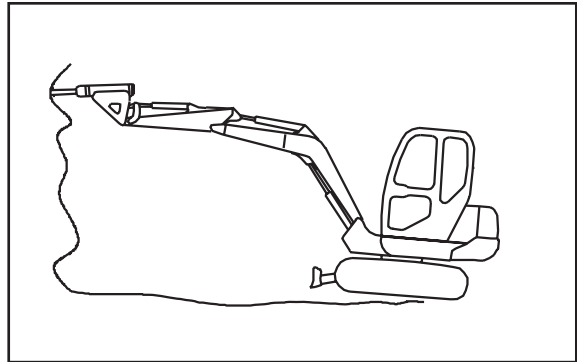

5) Waver the crush hammer when it penetrate the rock

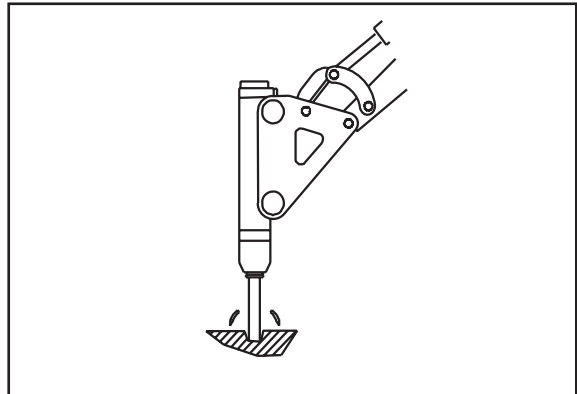

6) Peck operation

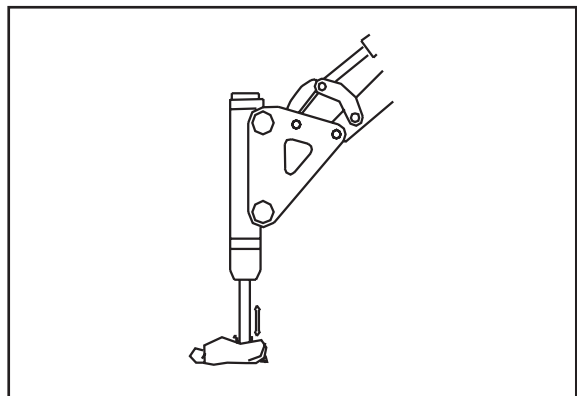

7) Operate it in the water or the muddy ground

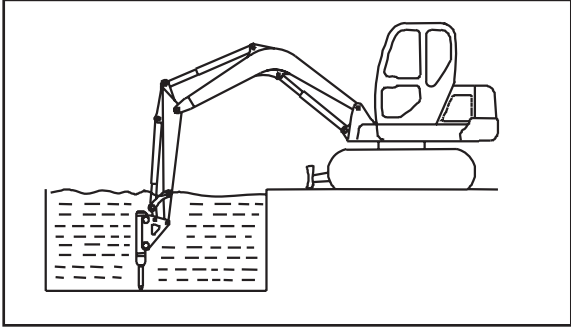

8) Use the crush hammer hang the heavy thing

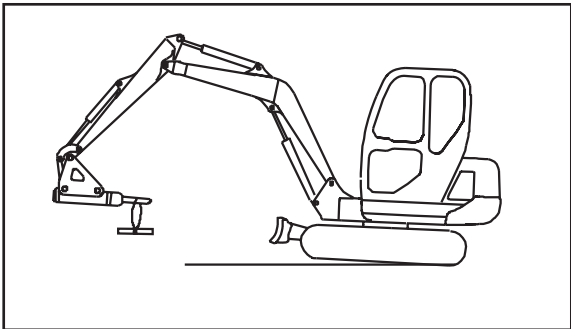

9) Throw out the oil tank of the bucket to make the machine leave the ground

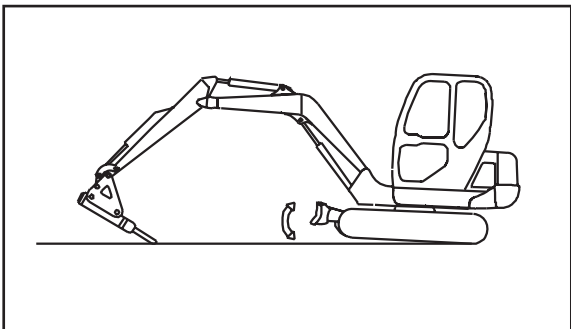

Fast-replace tie-in

1. Install the bucket

1) Use the tommy bar to prize ①

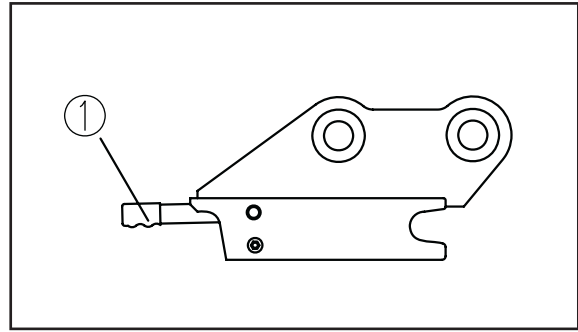

2) Put the axes of the bucket into the ②
③, down the tommy bar and the bucket
installed.

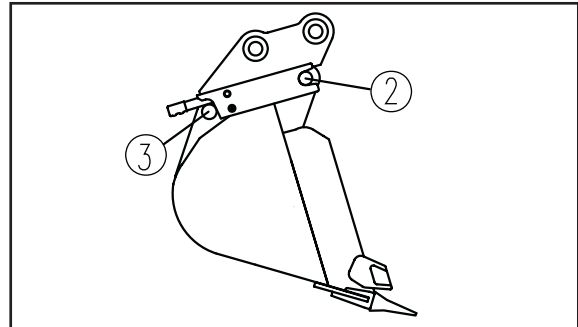

2. Take-down the bucket

1) Use the tommy bar to prize ①

2) Take down the bucket.

Daily Check of Hydraulic Crush Hammer

Do the daily check and the maintenance as the following list:

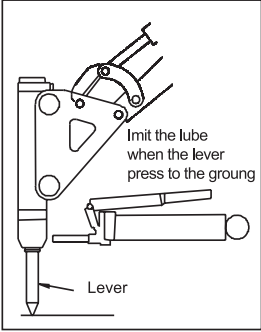
No.	Check or maintain item	Check point	Resolve
1	Check whether the bolt/nut loose or lose	Bolt of the main machine and the side of the bolt	Screw down the bolt or install the new bolt again
2	Check whether the parts of the soft pipe loose and the soft pipe break or leaks oil	Hydraulic pipeline of the crush hammer High-pressure vitta Use the lube to lubricate	Screw down the part which loose Replace the broken part
3	Lubricate 	before the operation and after operate 2-3hours Immit the lube 5-10times when lubricate.	Immit the lube thought the sprue which in the foreside of the crush hammer.
4	Check the capacity of the hydraulic oil and the pollution circs	The circs of the hydraulic	The change circs of the hydraulic oil is different as the different condition. The simple way to judge the oil is observe whether the color changes If the oil wroste,please vent the oil and clean the oil tank,Immit the new oil

Appendix:

Black Manual of The Certification

Backside of the certification has six circles in the bottom (see the picture).They are used to indicate the equipments of the product.

合格证
CERTIFICATE OF QUALITY

型号 Model _____
编号 Serial No. _____

1、各项性能符合设计要求。
All kinds of performance conform to the demand of design.

2、本机应带的备件、工具和文件已齐全。
The spare parts, tools and documents of the machine are prepared.

3、经检验合格准予出厂。
Qualified permits after test.

检查员
Inspector _____
出厂日期
The date of manufacture _____

中国 CHINA 广西 GUANGXI

玉柴工程机械有限责任公司
YUCHAI ENGINEERING MACHINERY COMPANY LIMITED
地址: 广西玉林市天桥路 168 号
Add: 168 Tianqiao Road, Yulin, Guangxi, China
电话: 0775-3289567 Tel: 0086-775-3289668

○ ○ ○ ○ ○ ○

○ ○ ○ ○ ○ ○
1 2 3 4 5 6

The meanings of the six circles are as follow:

1. With imported oil tank: black the first circle
2. With imported power: black the second circle
3. With the air-condition: black the third circle
4. With the nonstandard bucket: black the fourth circle
5. With the nonstandard lever: black the fifth circle
6. With the nonstandard moving-arm: black the sixth circle
7. With the home made oil tank、 the home brewed power、 without the air-condition、 the standard moving-arm and the lever、 the bucket: not black the six circles

As the different equipments, it can be black one or more or empty.