

DISD

SD300N

Main Performance Parameters (Standard Configuration)

Total Operating Mass :	16,500 KG	Max. Traction Force :	164 KN
Rated Load :	5,000 KG	Max. Dump Height :	3,027 mm
Rated Power :	162 KW	Min. Turning Radius(at bucket edge) :	6,680 mm
Rated Bucket Capacity :	2.7 ~ 4.0	Overall Dimensions	
Max. Breakout Force :	164 KN	(Length X Width X Height) :	7,780 X 2,992 X 3,470 mm



The most efficient expert in loose bulk materials transfer!

Integrated with 40 years of international standard professional loader manufacturing technologies, Little Giant is suitable for Emerging countries's working conditions.

SD300N

Key features

MAIN PERFORMANCE FEATURES

- The Weichai Steyr low-RPM engine features an oil pump that has accepted professional test bench special adjustment, making engine acceleration performance much higher than industry level.
- Reasonable match between transmission and torque converter as well as fully play of engine power enable the whole machine to deliver stronger traction force-14% higher than industry level.
- The advanced drive axle and improved differential bevel gear process have increased gear flexural strength by 34.6%, enhancing the reliability of the drive axle and extending its lifespan.
- With 2,900mm wheel base and turning radius reduced to 6,678mm, the machine model is specially designed for light materials, enabling greater agility of movement and more efficient operation.
- Manufactured according to a reasonable and optimized design based on typical working conditions, the hydraulic system adopts double-pump confluence technology, and makes full use of power and energy, thereby minimizing engine oil pressure load and power loss and enabling miniaturization of the hydraulic pump.
- The hydraulic cylinder seals and hydraulic holes in important areas are all imported brand parts, effectively improving the reliability of the hydraulic system.
- By using Doosan patented technology and a redesigned layout and materials, the cooling system significantly reduces hydraulic oil temperature and water temperature during operation and is capable of ensuring the unit's capacity to work 24hrs continuously under 45 C of temperature without risk of overheating.
- Paints imported from South Korea offer more outstanding anti-rust and anti-fade effects.



Materials and Specifications in the catalogue are subject to change without notice.

High Efficiency, Energy Saving

Smart Shape, Giant Strength

SD300N

Perfect Match between Power and Speed, Unrivalled Work Efficiency in the Industry



“DISD – A Pioneer of Low-RPM Engine Matching Technology!”

Engine

With 162KW rated power and 2,000 rpm rated rotation, the Weichai Steyr WD10G220E23 engine has been adjusted on the basis of condition subdivision, enabling lower fuel consumption in the most commonly used operating states.



Turbo Charged

Large torque reserve, low fuel and oil consumption rate, and good plateau adaptability comply with State II emission standards.

2,000 rpm low-speed + perfect power matching + double pump confluence technology make Doosan loaders more fuel efficient (about 10%) than the competitors' products under the same working conditions.

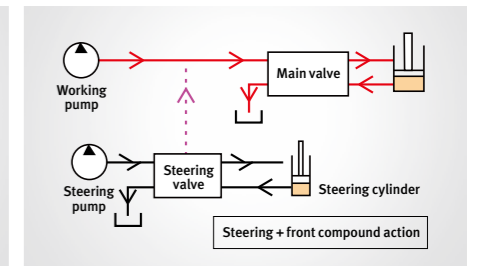
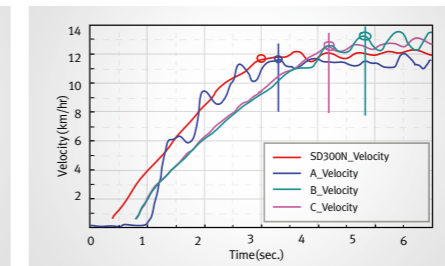

GearBox

The torque converter gearbox from an established domestic manufacturer perfectly matches the engine, while Doosan's uniquely designed and patented gearshift-shock-improving technology efficiently prolongs the service life of the gearbox.

Acceleration Performance Exceeds Industry Level

The injection pump has undergone special debugging at a professional test bench and features greatly improved engine acceleration performance, enabling Doosan machines to start work in the 3rd second while other brand machines are still in the acceleration phase.

Advanced Double Pump Confluence Technology

The hydraulic system uses condition subdivision to realize a reasonable match, and makes full use of power and energy, thereby minimizing engine oil pressure load and power loss and enabling miniaturization of the hydraulic pump.

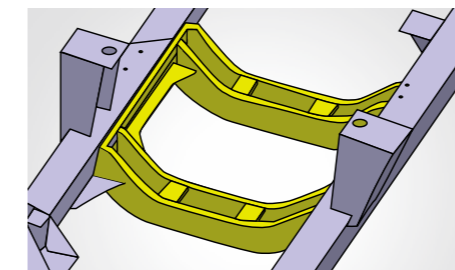

Connecting parts of swing frame adopt a reinforcement design to offer greater strength.

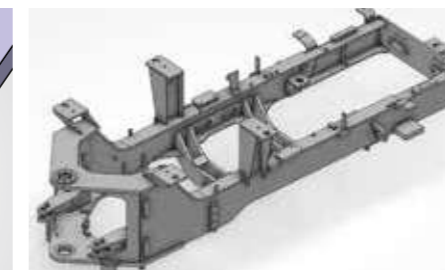

Thanks to the box-shaped structure of the rear frame side plates, the enhanced frame strength makes it easy to meet the challenge posed by harsh working conditions.



The whole center of gravity has been moved backward, and the real axle load bearing proportion has been increased to 54% resulting in a tipping load 10% higher than the industry level and greatly improved product stability.

Increasing the tilting angle a3 in the carry position allows the machine to move on bumpy roads without spilling any material, while increasing the dump angle a2 enables the machine to dump materials more quickly and completely.

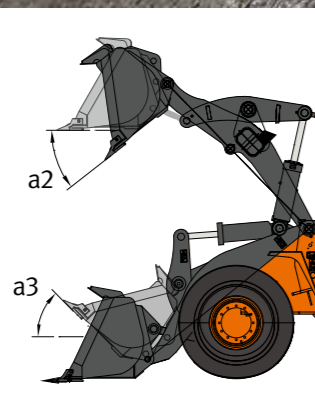

With a 2.9m wheelbase and a 6,678mm turning radius at the bucket edge, which is the smallest among similar products in the industry, Doosan's machine is specifically designed for light density material working conditions and offers greater overall flexibility, as well as more apparent advantages especially in confined work spaces.

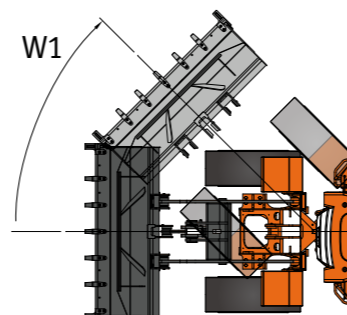

Reliability

Low Oil Temperature for High Quality

SD300N

Greater Reliability Ensured by Efficient Cooling, 24 Hours Continuous Work under 45°C Environment without Risk of Overheating

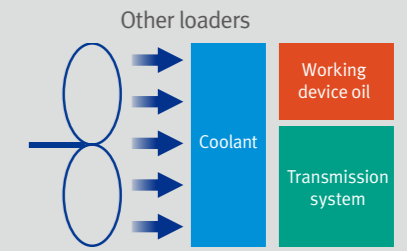

Cooling System

By improving the cooling system's layout and materials, DISD's unique patented cooling technology greatly reduces hydraulic oil temperature and Coolant temperature during the machine's operation time, thus resolving the high temperature problem that has been hanging over the industry for many years. The machine is guaranteed not to overheat even after 24hrs of continuous work under 45°C atmospheric temperature.

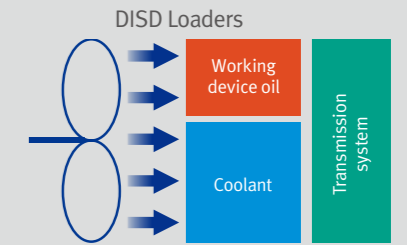

The hinge pins for operating devices in 6 positions have a radius of 5-10mm larger than similar products in the industry. The pin roll sets are made of highly wear-resistant materials and processed with a special heat treatment technology, thus offering greater durability and second-hand residual value.

The method of articulating the front and rear frames has been changed by replacing tapered roller bearings with joint bearings, effectively preventing such common problems as loose and breakage in the industry.

Hydraulic Seal Piping

The adoption of Eaton brand parts has greatly improved the quality of the hydraulic system. In addition, all of the hydraulic parts must satisfy the endurance test standard in South Korea to ensure the high reliability of Doosan's loaders.

Drive Axle

Drive axle and improved differential bevel gear processing have increased gear flexural strength by 34.6%, improving the reliability of the drive axle and extending its lifespan.



Hydraulic System Action Time: 9.5 seconds

The sum total of the times of the three actions (lifting 5.5s, dumping 1.2s, lowering 2.8s) is 9.5s, which is much faster than the industry level, leading to a shorter cycle operation time and greater efficiency.



Transmission Shaft

The use of a reinforced drive shaft and a self-locking nut for the drive shaft's connecting bolt has improved the durability of the drive system.



Structural Parts

Made of high-strength steel and calculated using finite element analysis software, it guarantees easy operations under the most onerous and toughest working conditions.



Multi-Way Valve

Adoption of new solid valves of well-known brands and processed with high precision, delivering good micro-motion performance, reduced internal leakage, and a prolonged service life.



Low Temperature Startup (Flame Preheating)

The low temperature startup device (Diesel electric heating + Air flame preheating) effectively improves work situations where it is difficult to startup in low temperatures during winter.

Comfort

Technology that Respects Human Health and Safety

SD300N

The whole system comes with a standard integrated driving system that respects human health and safety, relieves fatigue, and improves work efficiency.



Cab Vision

DISD's New Full Vision Cab adopts Korean technology. The viewpoint has been moved forward and the front visual field has been broadened by 25%, while the installation of high-performance damping material guarantees superior sealing, sound insulation, shock absorption effects.

The upgraded SD300N model guides operations, improves work efficiency, relieves fatigue, and is operated more comfortably and easily. The operating environment in the cab boasts an optimized ergonomic design, has plenty of space and a good visual field, and delivers safe and reliable protection on the basis of a people-oriented conception.



Cab

The cab's interior features an ergonomic design, a super-large driving space, wider front and rear visual fields, a user-friendly design for easier operability, and industry-leading driving comfort. A new model of shock pad is used to provide stronger durability and reduced shock and noise, effectively relieving the driver's fatigue.



SD300N



Shock Pad

A new model of shock pad is used to provide stronger durability and reduced shock and noise, effectively relieving the driver's fatigue.



Entertainment System

High-quality audio entertainment systems (MP3, radio) create a pleasant and relaxed work environment. A USB port is also available for charging mobile phones.

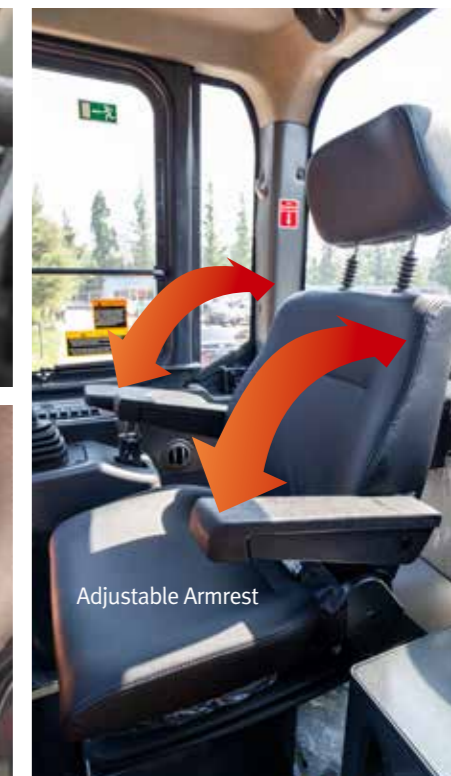

Adjustable Armrest

Deluxe Seat

High back, deep-seated position, dual armrests and multi-level spring shock absorption guarantee a comfortable operation.



All-metal hood, greater durability



Both sides of the hood can be side-opened.

Easier Replacement

The use of quick-change brake discs allows the user to check brake pads for excessive wear at any time and change the brake pads more easily without needing to remove the tires.



The booster pump delivers a higher augmented-thrust ratio, more stable braking performance, and more convenient daily maintenance thanks to its being mounted on the body's side.

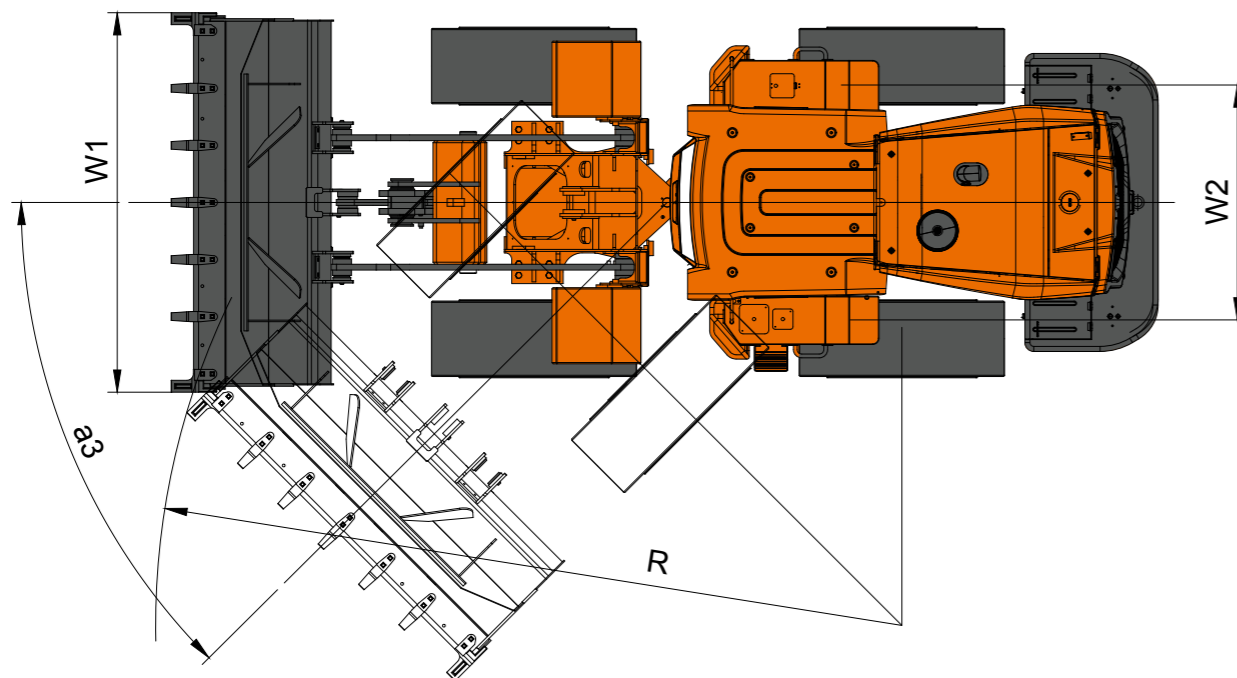
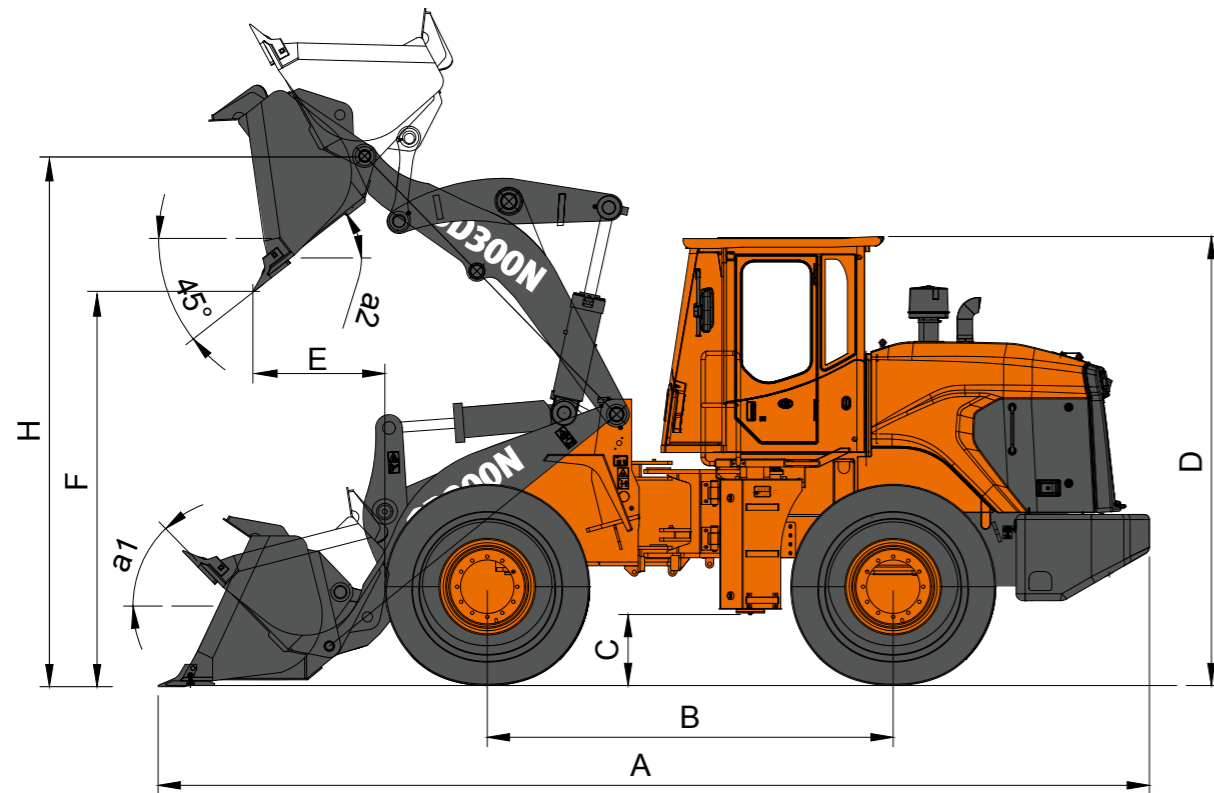

General Specification

Operating Weight	
Machine Dimensions (A x W1 x D)	7,780 X 2,992 X 3,470 mm
Ground Clearance (C)	480 mm
Wheel Base (B)	2,900 mm
Tread (W2)	2,174 mm
Turning Radius (R)	6,680 mm
Steering Angle (a3)	36 deg

Working Range

Dumping Height (F)	3,027 mm
Dump Reach (E)	1,338 mm
Max. Dump Angle (a2)	48°
Max. Tilt Angle on Ground (a1)	45°
Pin HINGE HEIGHT (H)	4,100 mm

General parameters

Bucket capacity	2.7 m ³
Operating weight	16,500 KG
Overall length x width x height (mm)	7,780 x 2,992 X 3,470
Rated load	5,000 KG
Wheelbase	2,900 mm
Tread	2,174 mm
Ground clearance	480 mm

Engine

Model	Weichai Steyr engine WD10G220E23 (turbocharged)
Rated power	162 KW
Rated speed	2,000 rpm
Number of cylinders/bores/strokes	6 / 126 / 130
Displacement	9.7 L
Max. torque	980N.m / 1,300 - 1,500 rpm

Optional items of equipment

Bucket	3.0 m ³
Enlarged coal bucket	4.0 m ³
Extended arm (dump height)	3,430 mm
Large-capacity air-conditioning	2.2 m ³
Timber grapples	

Transmission system

Torque converter	Twin turbo		
Gear box			
Planetary gear	Multiple disc	Anti-shock power	
shift	clutch	shift	
Gear position	I	II	
Forward	1-12.2 km/hr	0-38 km/hr	
Backward	0-16.5 km/hr		
Drive form	Four-wheel drive		
Rear axle swing angle	11°		
Tire	23.5 - 25 - 16 PR		
Max. traction force	164 KN		
Max. climb angle	30°		
Max. steering angle	36°		
Min. turning radius (Bucket edge)	6,680 mm		

Capacity

Fuel tank capacity	260 L
Hydraulic oil tank capacity	260 L
Engine oil	19 L
Gear box oil	49 L
Drive axle oil (front/rear)	27 L / 27 L

Working device

Max. dump height	3,027 mm
Dump reach	1,338 mm
Max. dump angle	48°
Max. breakout force	164 KN
Pin Hinge Height	4,100 mm

Hydraulic system

Pump type	Gear pump			
Pump displacement	100mL/r			
System operating pressure	17MPa			
Front cycle time	Lifting	Dumping	Lowering	Total
	5.5 s	1.2 s	2.8 s	9.5 s

Loading Material Unit Weight (Please determine the precise loading material weight according to the densities of the different materials given in the Table.)

Material Name	Density Kg/m ³	Material Name	Density Kg/m ³	Material Name	Density Kg/m ³	
Rubble	1,600	Dry	1,550	Sand rock	Crushed 1,550	
Mine refuse	650	Wet	1,725		Solid 2,300	
Clay	Dry excavated	1,485	Soil	Fine clay	1,125	
	Wet excavated	14725		Tight	1,840	
	Natural	1,650		Soft slurry	1730	
Clay and grave	Dry	11,185		Dry compacted soil	1,520	
	Wet	1,650	Granite	Crushed	1,650	
Coal	Smoke-free raw coal	1,190			Solid	2,800
	Smoke raw coal	950		Crushed	1,810	
Weathered granite	75% rock,25% soil	1955	Plaster	Crushed	1,600	
	50% rock,50% soil	1,725			Solid	2,780
	25% rock, 75% soil	1,585	Limestone	Crushed	1,550	
Pit gravel	1,900			Solid	2,600	
Gravel	Dry	1,485	Peat coal	Dry	415	
	Dry(1/4" -2")	1,650			Wet	1,125
	Wet(1/4" -2")	2,015	Alumina		1,425	
					Sand and gravel	Dry 1,730
						Wet 2,000
					Furnace cinders	Crushed 1,760
						Solid 2,100
					Trappide	Crushed 1,740
						Solid 2,880
					Hematite	2,460
					Magnetite	2,780
					Iron pyrites	2,580
					Taconite	2,800

Noise

Noise at driving position	≤85 dB(A)
Machine exterior radiated noise	≤112 dB(A)

DISD

Materials and Specifications in the catalogue are subject to change without notice.



DIPBE-02-2111

<https://tractormanualz.com/>