

Specification

Overall working weight	kg	17,300	Front and Rear Axles		
	lb	38,140	TYPE		FULLY FLOATING PLANETARY-TYPE HUB DRIVE
Capacity heaped ISO/SAE	m ³	3.0			FIXED MOUNTING(FRONT)
	yd ³	3.9			TRUNNION MOUNTING(REAR)
Rated load	kg	5000	Final decelerate type		PLANETARY
Max traction force	Ton	17	Tyre		
Max breakout force (kN)	kN	161	Tyre specification		23.5 -25-16PR
	lbf	36,194	Front tyre pressure	Mpa	0.38
Max gradability	Degree	30	Rear tyre pressure	Mpa	0.34
Dump height (at 45°) 1)	mm	3085	Steering System		
(at fully raised)	ft in	10'1"	Type		Gear
Dump reach (at 45°) 1)	mm	1,297	Steering angle	degree	40
(at fully raised)	ft in	4'2"	Min. turning radius (outside tires)	mm	5800
Overall dimension(LxWxH)	mm	8260 × 2992 × 3450	Min. turning radius (outside bucket)	mm	6510
				ft in	21'4"
Engine			Hydraulic system		
Model	Doosan DE08TIS (TIER-II Certified)		System working pressure	bar	170
Type	TURBO, DIRECT INJECTION		Boom lifting(full load)	sec	← - 6.0
Number of cylinder	6		Total time	sec	← - 11.3
Bore/stroke (mm)	111 X 139 (mm)		Brake system		
Max torque	902 N.m/1300 rpm		Service brake	AIR PUSH HYDRAULIC SINGLE LINE	
Rated power	160kW(215HP)/2,000 rpm		Parking brake	SPRING-APPLIED AIR RELEASED DRUM BRAKE	
Rated speed	2000 rpm		Fill capacity		
Min fuel consume ratio	215 g/kw.h @ RATED SPEED		Fuel	liter	330
Transmission system			Hydraulic oil	liter	177
Torque converter type	Single Stage, Single phase, Three elements(single turbine)				
Torque ratio	2.142				
Transmission type	4 SPEEDS, POWER-SHIFT, COUNTERSHAFT				
Gear shift	4 forward shift , 3 back				
Max speed	km/h	38.0 KPH			

* Specifications are subject to change without notice for quality improvement.

Dimension

A. Height to top of cab and canopy	mm	3450	K. Dump height (at 45°) 1)	mm	3085
	ft in	11'3"	(at fully raised)	ft in	10'1"
B. Ground clearance	mm	420	L. Maximum rollback at ground	degree	45
	ft in	1'37"	Max. tilt angle at ground		
C. Machine center point to rear axle		1600	M. Hinge pin height at carry position	mm	500
D. Wheel base	mm	3200	N. Maximum digging depth	mm	120
	ft in	10'6"		ft in	5"
E. Overall length	mm	8260	O. width over tires	mm	2750
	ft in	27'1"		ft in	9'2"
F. MAX. TILT ANGLE (fully raised)	degree	60.5	P. Tread width	mm	2150
G. Bucket dump at full height	degree	49		ft in	7'0"
H. Dump reach (at 45°) 1)	mm	1297	Q. turning radius outside tires	mm	5800
(at fully raised)	ft in	4'2"		ft in	19'0"
I. Maximum overall height	mm	5713	R. Maximum steering angle (each side)	degree	40
J. Hinge pin height at full lift	mm	4150	S. Bucket width	mm	2992
	ft in	13'7"		ft in	9'9"
			T. Turning radius outside bucket	mm	6510
				ft in	21'4"

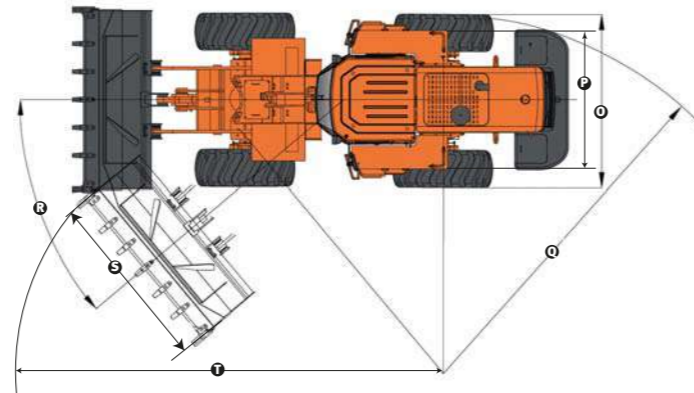
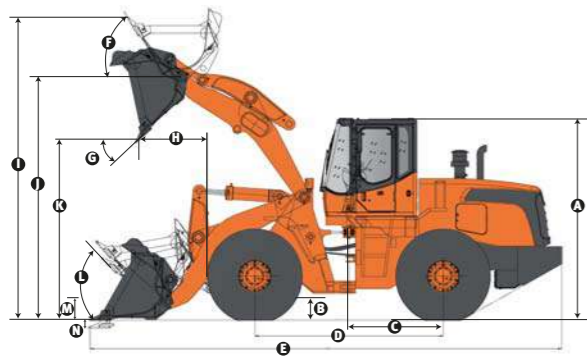

1) Measured to the tip of the bucket teeth or bolt-on edge.

2) SD310: All measurements with tyres 23.5-25-16PR(L3)

DISD

Wheel Loader SD310



No. 1088, Xincheng Street, Muping Economic Developing Zone
Yantai Shandong 264100 China
Tel: +86-10-8454-7075 Fax: +86-535-470-7431

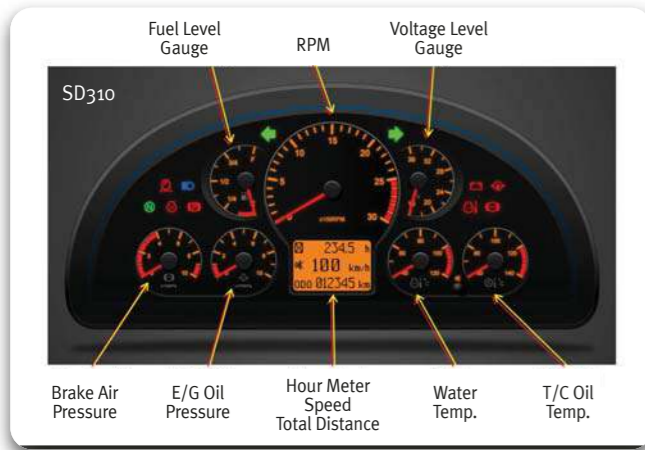

New Operator Panel
The instrument panel has been changed to improve operator comfort and convenience.

Doosan DE08TIS engine ▶
Fuel saving and environment friendly low-speed engine, satisfying Tier-II emission standards. Our many years of experience in engine design and production have resulted in the emergence of a highly efficient and very powerful engine that boasts the highest power in its class.



Rearward Visual Field broadened by 20%
The rear end of the device adopts streamline design which largely broadens the rearward visual field of the operator, improving not only the work efficiency but also safety.



Rear Wiper
In case of rain, a lot of dust in the work environment, improving rear visibility.

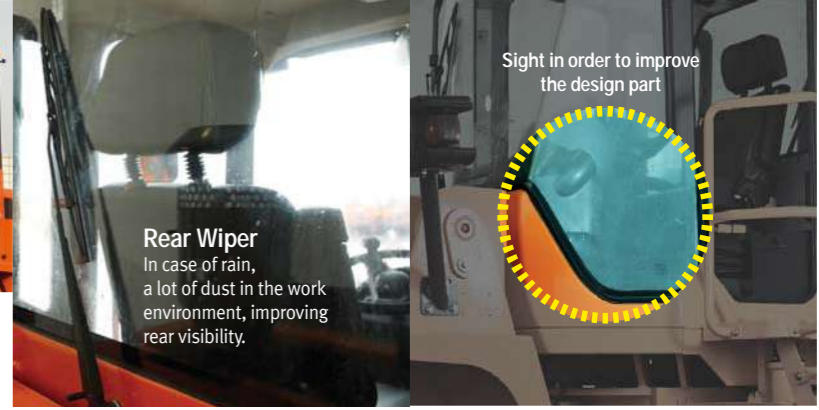

Sight in order to improve the design part

Excellent Performance for The Best Job

SD310 features powerful performance under poor working conditions with high efficiency and fuel saving operation. Well integrated high quality main components make it possible.



Fast Operating Speed
Significantly improved work progress, reduced work time, and reached excellent perfectly balanced for optimal work efficiency.



Quickly Changeable Brake Disc
Brake disc can be replaced quickly and easily without disassembling tires, deeply shortening the maintenance time and saving time and labor cost.



High Efficiency Cooling Fan
The cooling fan of non-isometric blades can reduce noise and increase air flow.



Full Tilting of Engine Cover
With this one body engine cover, it is easy to repair engine and sub parts.



Easy and Quick Adjustable Maintenance Window
The 180°side-opened maintenance window provides a quick and direct view for inspection, largely saving daily monitoring and maintenance time.



Tipping load
Tipping load of Doosan equipment greater than products from competitors for realizing stable digging work.



Strong Breakout Force
Released through the best combination of hydraulic systems, under any working conditions, to create outstanding results.



Tropical radiator
Tropical radiator applied to SD310 for allowing operation in tropical zones such as deserts in the Middle East, and keeping its performance high.



Traction force
Traction force far more excellent than products from competitors allowing exercise of powerful force during operation.



DISD in house axle
Axles developed by DISD proven of high quality and durability. In-house axle allowing rapid and stable part supply. (SD310)

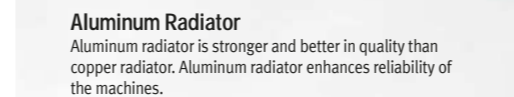

Aluminum Radiator
Aluminum radiator is stronger and better in quality than copper radiator. Aluminum radiator enhances reliability of the machines.



Air conditioning condenser assembled with radiator
- No electric fan motor for air conditioning condenser.
- Air conditioning condenser is integrated with radiator assembly and has less quality problems caused by electric fan motor.



Solid Frame Structure
The most advanced 3D CAD and FEM technologies are adopted in the analysis of technical design, greatly improving the strength, durability and reliability of the device.

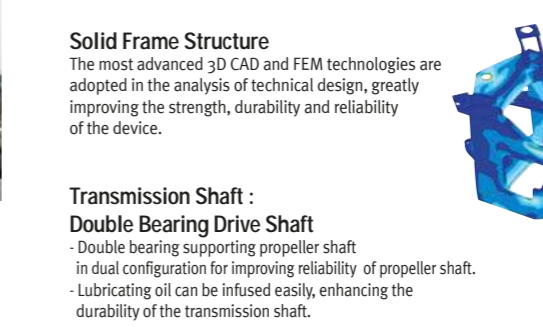

Transmission Shaft : Double Bearing Drive Shaft
- Double bearing supporting propeller shaft in dual configuration for improving reliability of propeller shaft.
- Lubricating oil can be infused easily, enhancing the durability of the transmission shaft.



Outdoor Power switch Used to cut off battery power when necessary to enhance maintenance safety and convenience while protecting the battery and extending battery life when the device is parked for a long time. (SD310, SD300, SD200)



Air Flow Increased by 30%
Excellent air-conditioning system and air circulation function as well as perfect defrost system provide operator a more comfortable operating environment and more easy controlling methods to benefit from the above functions.

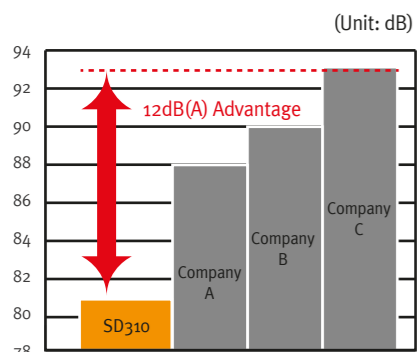

Lower Noise
Offering a quiet and comfortable working environment and improving efficiency. (SD310 - Indoor noise levels : 81dB, The noise level of the equipment outside : 112dB)



Cabin
- Enough space.
- Wide visual field.
- Noise inside cabin is lower than comparative units.
- Comfortable operating space.
- Multi-angle adjustable steering wheel.



ZF transmission
Full automatic transmission for streamlined speed change with four forward gears and three backward gears. (SD310)

Features of DISD wheel loader

- Stronger breakout force and tractive force, reflecting excellent performance in a high-load working environment.
- Ideal operating speed and 40°steering angle, sharply improving work efficiency.
- Low-speed engine, saving more fuel for the device.
- Reasonable matched top-end technology, ensuring a more reliable, durable and efficient device.
- Noise reduction technology in line with international standards, providing operator with physical and mental protection, while bolstering work efficiency.
- Industry leading cooling system, offering a guarantee for continuous and uninterrupted work under high temperatures.
- Streamlined appearance and wide operating room, representing an international brand style.