

Schäffer

2345 T - 9660 T

TELE WHEEL LOADER

Expertise for the construction industry



**ONLY WHEN PERFORMANCE
MEETS PERFECT QUALITY,
can driving pleasure become standard equipment.**

SCHÄFFER

From 15 kW (20 HP) to 115 kW (157 HP). For over 60 years, we have been developing loaders to meet individual requirements. Customer satisfaction has made us what we are today: One of the most capable and successful suppliers of farm loaders, wheel loaders and tele wheel loaders ever. Every day our employees create new, customised solutions.

Every Schäffer loader is the result of years of experience and innovative thinking. Our products set standards in terms of the highest possible reliability and durability. With lower costs throughout the whole operating life. With even more performance, safety and driving comfort for many years to come.

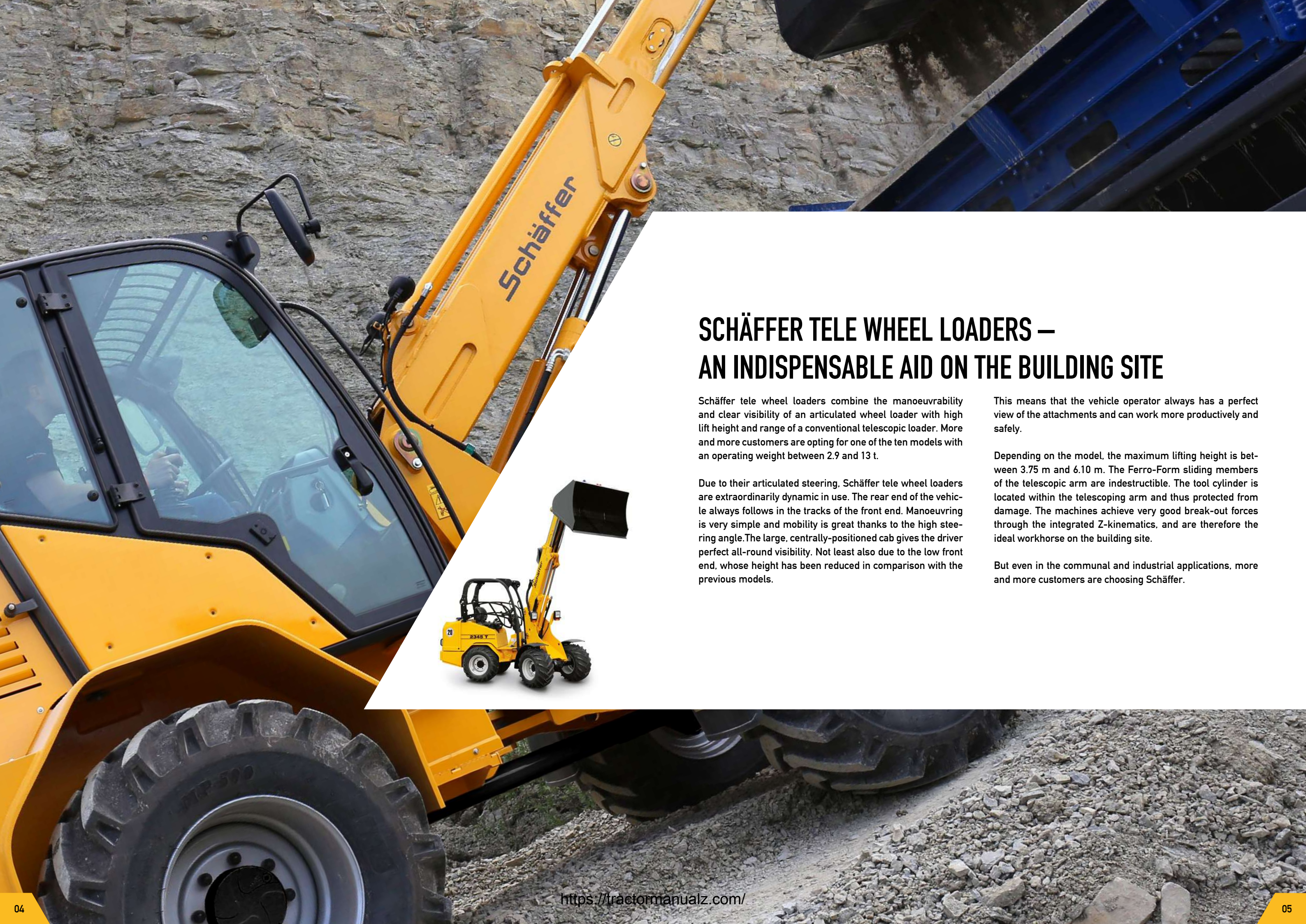

SCHÄFFER TELE WHEEL LOADERS – AN INDISPENSABLE AID ON THE BUILDING SITE

Schäffer tele wheel loaders combine the manoeuvrability and clear visibility of an articulated wheel loader with high lift height and range of a conventional telescopic loader. More and more customers are opting for one of the ten models with an operating weight between 2.9 and 13 t.

Due to their articulated steering, Schäffer tele wheel loaders are extraordinarily dynamic in use. The rear end of the vehicle always follows in the tracks of the front end. Manoeuvring is very simple and mobility is great thanks to the high steering angle. The large, centrally-positioned cab gives the driver perfect all-round visibility. Not least also due to the low front end, whose height has been reduced in comparison with the previous models.

This means that the vehicle operator always has a perfect view of the attachments and can work more productively and safely.

Depending on the model, the maximum lifting height is between 3.75 m and 6.10 m. The Ferro-Form sliding members of the telescopic arm are indestructible. The tool cylinder is located within the telescoping arm and thus protected from damage. The machines achieve very good break-out forces through the integrated Z-kinematics, and are therefore the ideal workhorse on the building site.

But even in the communal and industrial applications, more and more customers are choosing Schäffer.



SCHÄFFER 3550T



POWER DELIVERY IN PERFECT SHAPE

Compact: tele wheel loaders are universally operable machines for any business. The 3500 series loaders with their 3.7 t operating weight deliver the perfect combination of strength, lifting height, range and manoeuvrability.

The lifting height and range, which are far greater than that of a normal compact wheel loader, open up entirely new application options. The loader's lifting height is 3.85 m, meaning that the vast majority of trucks can be loaded with ease. No compromises were made in terms of lifting capacity. The tipping load is substantial at up to 1.7 t, thus enabling powerful loading cycles. Thanks to their articulated steering, the loaders are extremely manoeuvrable. Manual labour can be mechanised wherever larger conventional telescopic loaders or large wheel loaders are simply too big, and too inflexible.



The 3550 T is also extremely easy to use off road.

[SCHAEFFER-LADER.COM/3550T](https://schaeffer-lader.com/3550T)



**OPERATING EFFICIENCY
WITHOUT COMPROMISES**



SCHÄFFER TELE WHEEL LOADERS: THE FLEXIBLE ALL-ROUNDERS

Schäffer tele wheel loaders offer a perfect combination of performance, comfort and reliability, and are suitable for operations of all kinds. The hydrostatic traction drive delivers high thrust forces coupled with very low fuel consumption.

The machine is very simple and intuitive. The view of the attachments is excellent. The comfortable seating position guarantees relaxed and productive work at all times for the driver.

Schäffer loaders not only increase productivity, but are also genuinely fun to drive. The mode of operation and handling are very similar to that of a conventional wheel loader. And it is correspondingly easy for a driver to adjust to a Schäffer tele wheel loader. After just a short learning curve, the driver will really appreciate the additional lifting height and reach.

Schäffer also offers a very wide range of work tools. Whether you need a pallet fork, a soil or light bulk materials bucket, a sweeper or snow plow for professional use – the tool quality standard is just as high as for the loaders themselves. From the 6680 T model, if desired, the machines can be equipped with a work cage for road-legal use.

Especially with the larger machines from the 8610 T up, it makes sense to look more closely at the different versions of the working hydraulics. The simplest variant is a gear pump whose power is already sufficient to meet many requirements. There are also heavy-duty gear pumps or flow-sharing hydraulics to choose from.

Another option is load-sensing work hydraulics with high performance and excellent efficiency.

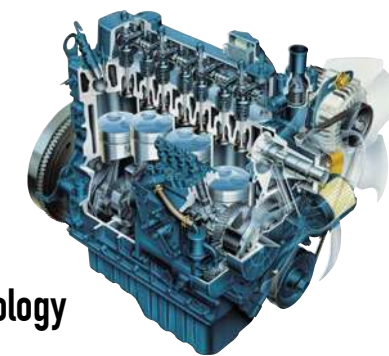

Engine technology by Kubota

Schäffer has relied on Kubota for over 25 years. The leading manufacturer of compact diesel engines has earned an excellent reputation in the face of demanding tasks on construction sites all over the world. Even at Arctic temperatures these engines start up easily. The engine sound conveys safety and strength. And the excellent torque band guarantees this. Just as important: Maintenance is easy to carry out. Service lives of 10,000 hours and longer are no exception.

Kubota engines are very economical and really utilise fuel to the max.



Original Schäffer axles – thrust without end

Original Schäffer axles are 100% tuned for each model. And that's the secret behind the superior thrust of all Schäffer loaders. Independent tests confirm this time and time again. Talking of safety: From the 3550 T model upward, the permissible load-carrying capacity is a massive 7 t per axle.

All tele wheel loaders are equipped with enclosed, multi-disc brakes that run in an oil bath. You can always rely on these brakes. They not only offer the best possible deceleration values, but are also completely maintenance-free. Dirt, dust or wear don't stand a chance.

ADDED VALUE AS A FACTORY STANDARD

Here are just six reasons that make these loaders value added machines:

1. The lifting height of up to 5.30 m in the 8 t class is simply exceptional.
2. The tool cylinder is protected within the telescoping arm. And this is easy on your budget in the long term.
3. The sliders in the telescopic arm are made of a special Ferro-Form composite. A long service life is guaranteed, as the material is practically wear-free.
4. Thanks to a low boom attachment point, and the new SCV cab, the driver enjoys excellent all-round visibility. The driver always has a perfect overview, and can thus work quickly and safely.
5. The rear axle is freely suspended and contributes to the excellent stability of the loader. Good for your safety, and for off-road use.
6. Deutz engine technology: Indestructible, economical, quiet and strong. An oxidising catalytic converter is used in the exhaust emission control system.



SCHAEFFER-LADER.COM/9630T



THE NEW SCV CABIN



EXTRA CLASS SPACE DIMENSIONS

The new Schaffer SCV cab (silence/comfort/view), with which the 6600, 8600 and 9600 Schaffer tele wheel loader series are equipped, offers more comfort for long working days. Even from the outside, the new cabin exudes value and freedom of movement.

Accessing the loader is a real treat thanks to the slip-proof steps and generously-sized doors. The interior design in friendly colours reflects Schaffer's typical high quality standards. The driver's seat even provides real comfort at the standard equipment level. On request, an air spring seat is also available. The steering wheel is adjustable both in height and inclination. All controls and displays are arranged clearly and logically.

The joystick for controlling all the hydraulic functions offers sensitive response. This is supported by the use of pilot-operated valves. Complete encapsulation ensures a low noise level (only 74dB). The armrest and joystick form a single unit with the seat, and follow all seat movements. This keeps the driver fit on long working days, too.

Thanks to generous glazing in all directions, the driver doesn't miss a thing, and can work productively and safely.

The new cabins are approved as per the ROPS/FOPS safety standards.

SERIAL HIGHLIGHTS



Perfect upward view, with sunblind



Storage compartment with cover (As of type 8610 T)



Heating with powerful, 3-speed blower



Battery master switch



Socket with permanent current



2 x Dual Power front working lights, 1 x Single Power at rear

**EFFICIENCY IS
DECISIVE**



TECHNICAL DATA

	2345 T	2345 T SLT	3550 T	3550 T SLT	5680 T
Engine	4 Cyl. Kubota Turbo, 33 kW (45 HP)	4 Cyl. Kubota Turbo, 33 kW (45 HP)	4 Cyl. Kubota, 37 kW (50 HP)	4 Cyl. Kubota, 37 kW (50 HP)	4 Cyl. Deutz Turbo, 55 kW (75 HP)
Traction hydraulics	hydrostatic-automotive, HTF	hydrostatic-automotive	hydrostatic-automotive, HTF	hydrostatic-automotive, HTF	hydrostatic-automotive, HTF
Tyres	10.0/75 - 15.3 AS or MPT Option: 31x15.5-15	10.0/75 - 15.3 AS or MPT Option: 31x15.5-15	15.0/55 - 17 AS Option: 425/55R17	15.0/55 - 17 AS Option: 425/55R17	15.0/55 - 17 AS Option: 425/55 R17
Service braking system	Combined brake hydrostatic and multi-disc brake	Combined brake hydrostatic and multi-disc brake	Combined brake hydrostatic and multi-disc brake	Combined brake hydrostatic and multi-disc brake	Combined brake hydrostatic and multi-disc brake
Parking brake	Multi-disc brake running in oil bath	Multi-disc brake running in oil bath	Multi-disc brake running in oil bath	Multi-disc brake running in oil bath	Multi-disc brake running in oil bath
Working hydraulics Output/pressure	Delivery rate: from 42 l/min Operating pressure: 200 bar	Delivery rate: from 42 l/min Operating pressure: 200 bar	Delivery rate: from 52 l/min Operating pressure: 200 bar	Delivery rate: from 52 l/min Operating pressure: 200 bar	Delivery rate: from 64 l/min Operating pressure: 220 bar
Steering	fully hydraulic articulated steering	fully hydraulic articulated steering	fully hydraulic articulated steering	fully hydraulic articulated steering	fully hydraulic articulated steering
Lifting capacity	1,900 kg	1,900 kg	1,950 kg	1,950 kg	2,400 kg
Tipping load, straight ¹	1,650 kg	1,650 kg	1,710 kg	1,710 kg	2,800 kg
Axles	Original Schäffer axles, 6-hole rim; Option: automatic slip-control differential	Original Schäffer axles, 6-hole rim; Option: automatic slip-control differential	Original Schäffer axles, 6-hole rim; Option: automatic slip-control differential	Original Schäffer axles, 6-hole rim; Option: automatic slip-control differential	Original Schäffer axles, 6-hole rim; planetary final drive and automatic slip-control differentials, swing axle at rear
Operating weight	Overhead guard: 2,850 kg Cab: 3,050 kg	Overhead guard: 2,900 kg	Overhead guard: 3,700 kg Cab: 3,900 kg	Overhead guard: 3,700 kg	Overhead guard: 4,300 kg Cab: 4,500 kg
Speed	0 - 20 km/h in 2 gears switchable under load Option: 0 - 28 km/h	0 - 20 km/h in 2 gears switchable under load	0 - 20 km/h in 2 gears switchable under load Option: 0 - 28 km/h	0 - 20 km/h in 2 gears switchable under load Option: 0 - 28 km/h	0 - 20 km/h in 2 gears switchable under load Option: 0 - 30 km/h
Electric system	Operating voltage: 12 V	Operating voltage: 12 V	Operating voltage: 12 V	Operating voltage: 12 V	Operating voltage: 12 V
Fill quantities	Fuel: 40 l Hydraulic oil: 30 l	Fuel: 40 l Hydraulic oil: 30 l	Fuel: 55 l Hydraulic oil: 50 l	Fuel: 55 l Hydraulic oil: 50 l	Fuel: 85 l Hydraulic oil: 75 l
Sound pressure level LpA	84 dB(A)	83 dB(A)	85 dB(A)	85 dB(A)	81 dB(A)
Sound power level guaranteed LwA equivalent LwA	101 dB(A) 98 dB(A)	101 dB(A) 98 dB(A)	101 dB(A) 100 dB(A)	101 dB(A) 100 dB(A)	101 dB(A) 101 dB(A)
Hand/arm vibration ²	< 2.5 m/s ²	< 2.5 m/s ²	< 2.5 m/s ²	< 2.5 m/s ²	< 2.5 m/s ²
Total body vibration ²	< 0.5 m/s ²	< 0.5 m/s ²	< 0.5 m/s ²	< 0.5 m/s ²	< 0.5 m/s ²

¹ Boom horizontal, not extended, with pallet fork (acc. to ISO 14397) ² according to ISO 8041

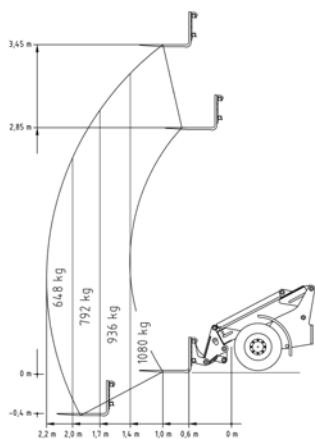

2345 T / 2345 T SLT **

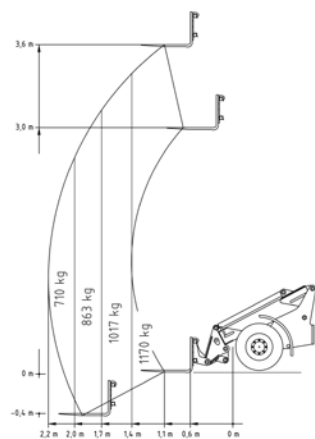

3550 T / 3550 T SLT **

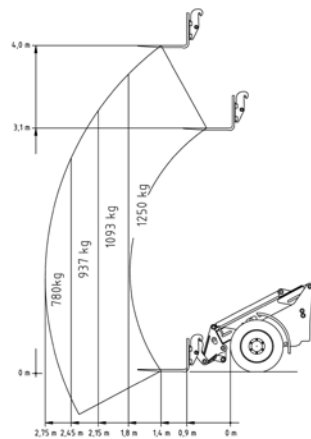

5680 T **

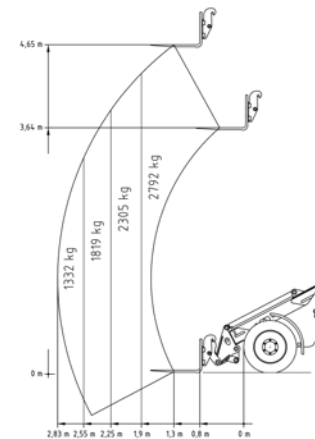

6680 T **

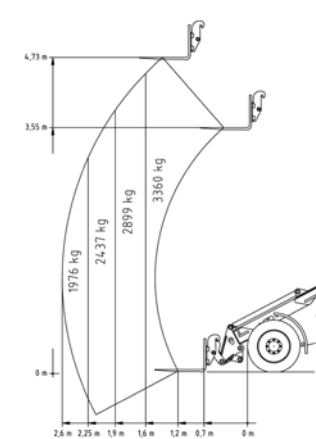

8610 T **

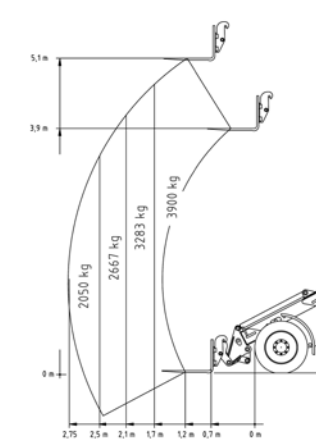

9630 T **

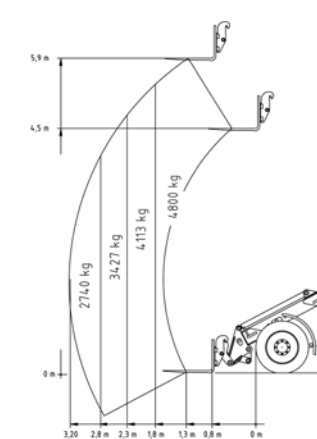

9660 T **

** Using forks on stable underground (according EN 474-3)

	6680 T	8610 T	9630 T	9660 T
Engine	4 Cyl. Deutz Turbo, 55 kW (75 HP)	4 Cyl. Deutz Turbo Common Rail, 75 kW (102 HP)	4 Cyl. Deutz Turbo Common Rail, 90 kW (123 HP)	4 Cyl. Deutz Turbo Common Rail, 115 kW (157 HP)
Traction hydraulics	hydrostatic-automotive, HTF	hydrostatic-automotive, HTF	hydrostatic-automotive, HTF	hydrostatic-automotive, HTF
Tyres	15.5/60-18 AS Option I: 15.5/55-18 Option II: 500/45-20	405/70-20 Option I: 550/45-22.5	18-22.5 TL AS Option I: 600/40-22.5 Option II: 500/60-22.5 Option III: 600/50-22.5	500/70-24 AS Option I: 600/55-26.5 Option II: 700/50-26.5 Option III: 650/55-26.5
Service braking system	Combined brake hydrostatic and multi-disc brake	Combined brake hydrostatic and multi-disc brake	Combined brake hydrostatic and multi-disc brake	Combined brake hydrostatic and multi-disc brake
Parking brake	multi-disc brake running in oil bath	multi-disc brake running in oil bath	multi-disc brake running in oil bath	multi-disc brake running in oil bath
Working hydraulics Output/pressure	Delivery rate: from 64 l/min Operating pressure: 220 bar	Delivery rate: from 105 l/min Operating pressure: 220 bar	Delivery rate: from 105 l/min Operating pressure: 220 bar	Delivery rate: from 172 l/min Operating pressure: 220 bar
Steering	fully hydraulic articulated steering	fully hydraulic articulated steering	fully hydraulic articulated steering	fully hydraulic articulated steering
Lifting capacity	3,100 kg	3,800 kg	4,200 kg	5,300 kg
Tipping load, straight ¹	3,800 kg	4,500 kg	5,000 kg	7,900 kg
Axles	Dana axles, 8-hole rim; planetary final drive and automatic slip-control differential, swing axle at rear	ZF HD axles 8 hole rim; planetary final drive and automatic slip-control differentials, swing axle at rear	Dana axles, 8-hole rim; planetary final drive and automatic slip-control differential, swing axle at rear	Dana axles, 10-hole rim; planetary final drive and automatic slip-control differential, swing axle at rear
Operating weight	Cab: 5,600 kg - 6,300 kg	Cab: 6,500 kg - 7,550 kg	Cab: 8,000 kg - 9,300 kg	Cab: 11,000 kg - 13,000 kg
Speed	0 - 20 km/h in 2 gears switchable under load, Option: 0 - 35 km/h	0 - 20 km/h in 2 gears switchable under load, Option: 0 - 35 km/h	0 - 20 km/h in 2 gears switchable under load, Option: 0 - 35 km/h	0 - 30 km/h in 2 gears switchable under load, Option: 0 - 40 km/h
Electric system	Operating voltage: 12 V	Operating voltage: 12 V	Operating voltage: 12 V	Operating voltage: 12 V
Fill quantities	Fuel: 95 l Hydraulic oil: 85 l	Fuel: 105 l Hydraulic oil: 94 l	Fuel: 140 l Hydraulic oil: 120 l	Fuel: 185 l Hydraulic oil: 170 l
Sound pressure level LpA	75.5 dB(A)	78 dB(A)	79 dB(A)	78 dB(A)
Sound power level guaranteed LwA equivalent LwA	101 dB (A) 101 dB (A)	102 dB (A) 101 dB (A)	102 dB (A) 101 dB (A)	103 dB (A) 101 dB (A)
Hand/arm vibration ²	< 2.5 m/s ²	< 2.5 m/s ²	< 2.5 m/s ²	< 2.5 m/s ²
Total body vibration ²	< 0.5 m/s ²	< 0.5 m/s ²	< 0.5 m/s ²	< 0.5 m/s ²

¹ Boom horizontal, not extended, with pallet fork (acc. to ISO 14397) ² according to ISO 8041

** Using forks on stable underground (according EN 474-3)

DIMENSIONS

All technical specifications in this prospectus refer to serial models and describe their standard functions. The equipment components and their functions as well as the accessories depend on the individual model and the product options and also on the country and customer specific requirements. Images may contain products or equipment components which are not mentioned or cannot be obtained as a standard. The descriptions, measurements, images, weight specifications and technical data correspond to the state of the art at the time of printing and are non-binding. We reserve changes in the field of construction, equipment, optics and technology without prior notice, due to the continuous development of the products. In case of doubts concerning the performance or the mode of operation of our products due to special circumstances, we recommend the execution of work samples under controlled conditions. We cannot exclude deviations from images or measurements, calculation errors, printing errors or incompleteness in the prospectus despite all due care. We do therefore not accept any liability for the correctness and completeness of the specifications in this prospectus. We do guarantee the proper functioning of our products within the scope of our General Terms and Conditions. Any guarantees that go beyond these are on principle not provided. Any liability beyond the ones set out in our General Terms and Conditions is excluded.

		2345 T	2345 T SLT	3550 T	3550 T SLT	5680 T
A	Wheelbase [mm]	1.850	1.910	1.920	1.920	1.960
B	Chassis length [mm]	4.100	4.200	4.070	4.070	4.350
C	Overall length with standard bucket [mm]	4.520	4.580	4.835	4.835	5.200
D	Digging depth [mm]	90	90	150	150	180
E	Reach [mm]	1.570	1.570	1.780	1.780	2.210
F	Max. bucket pivot point. [mm]	3.750	3.750	3.850	3.850	4.250
G	Loading height with pallet forks [mm]	3.470	3.470	3.580	3.580	4.020
H	Max. dumping height [mm]	3.010	3.010	3.150	3.150	3.330
I	Front end height [mm]	1.580	1.580	1.600	1.600	1.580
J	Dumping width [mm]	820	820	890	890	1.160
K	Seat height [mm]	955	1.160	1.180	1.180	1.290
L	Cab height [mm]	2.110	-	2.230	-	2.320
	Top height [mm]	-	-	-	-	-
	Overhead guard height [mm]	2.215	from 1.950	2.270	from 2.040	2.320
N	Overall width [mm]	1.280-1.570	1.280-1.570	1.420-1.640	1.420-1.640	1.500-1.710
O	Inner turning radius [mm]	950	980	1.230	1.230	1.580
P	Outer turning radius [mm]	2.550	2.580	2.620	2.620	3.310
Q	Outer radius with standard bucket [mm]	2.850	2.880	2.970	2.970	3.820

		6680 T	8610 T	9630 T	9660 T
A	Wheelbase [mm]	2.450	2.480	2.520	2.900
B	Chassis length [mm]	5.050	5.090	5.200	5.800
C	Overall length with standard bucket [mm]	5.780	6.040	6.130	6.750
D	Digging depth [mm]	100	120	130	80
E	Reach [mm]	2.360	2.550	2.970	3.300
F	Max. bucket pivot point. [mm]	4.900	5.100	5.300	6.100
G	Loading height with pallet forks [mm]	4.650	4.770	5.100	5.900
H	Max. dumping height [mm]	3.930	4.190	4.700	5.100
I	Front end height [mm]	1.700	1.780	1.850	2.190
J	Dumping width [mm]	815	730	750	850
K	Seat height [mm]	1.420	1.510	1.600	1.880
L	Cab height [mm]	2.430/2.530 ^{*2}	2.500/2.600 ^{*2}	2.740/2.640 ^{*1}	2.970
	Top height [mm]	-	-	-	-
	Overhead guard height [mm]	-	-	-	-
N	Overall width [mm]	1.590-1.900	1.850-2.080	2.075- 2.400	2.290-2.490
O	Inner turning radius [mm]	1.750	2.240	2.240	2.400
P	Outer turning radius [mm]	3.360	3.650	3.900	4.200
Q	Outer radius with standard bucket [mm]	4.000	4.350	4.430	4.650

*1 Option: low cab *2 Option: high cab

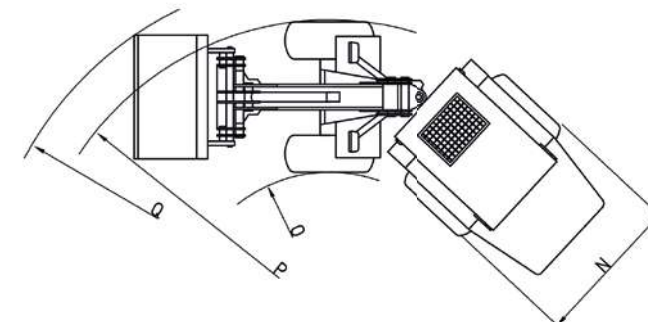
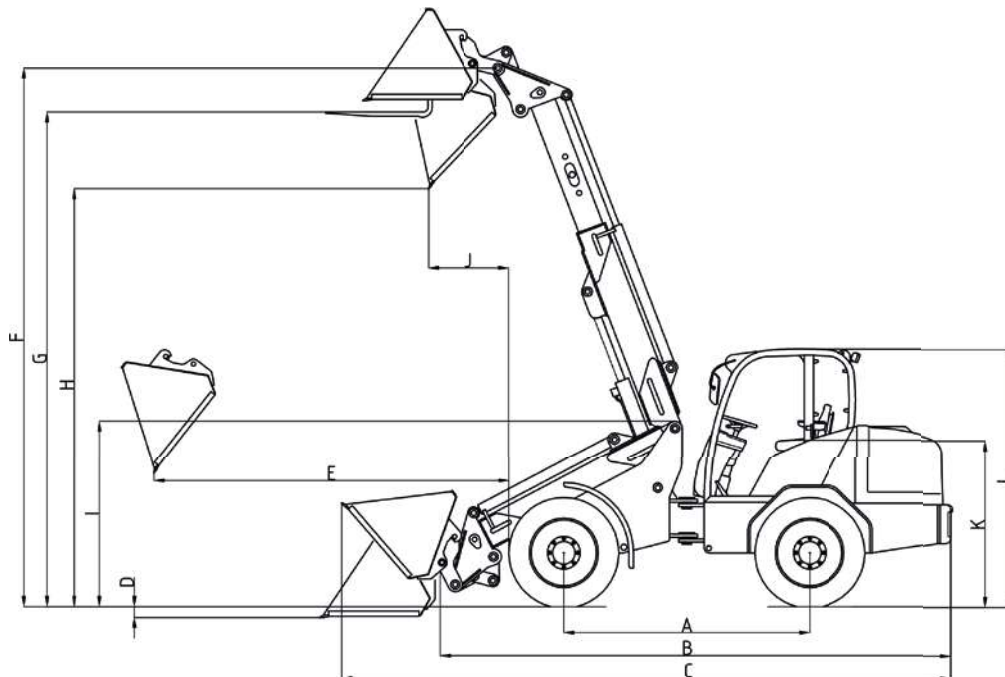



made by **SCHÄFFER**

Schäffer offers a programme with 40 different models, each adapted to your needs. Our loaders' range of operations is versatile: whether in agriculture or construction, gardening and landscaping, industrial and commercial applications, in stabling or warehouse management – Schäffer is always your best choice.

The way Schäffer loaders are developed, produced and serviced is unique. The real difference is our experience of more than 60 years. We think of the end user first, because we seek to make your job safer, more comfortable and more profitable. Additionally, at our Erwitte location in Germany we rely on state-of-the-art development and production technologies. Ultimately, it is our employees who continuously develop new solutions, in close contact with the end user. Years of company service together with an enduring spirit form the basis for the special competence and for our global success.

The Schäffer name does not just mean unique product quality. It also stands for safety and optimal service that we guarantee both in Germany, Europe and around the globe.

Purchasing a Schäffer loader is the beginning of a long-term relationship. Your machine will only remain a 100% genuine Schäffer if you use original replacement parts. Only then will it guarantee the reliability you need, and have the right to expect. We offer you and our service partners a 24 hour delivery service – 7 days a week, 365 days a year.



YOUR DEALER:

Schäffer

Schäffer Maschinenfabrik GmbH
Postfach 10 67 | D-59591 Erwitte
phone +49 02943 9709-0
fax +49 02943 9709-50
info@schaeffler-lader.de

WWW.SCHAEFFER-LADER.COM

