

Language: English
Geographic Region: All
Serial Number Range: SN 00101-03704



PT50

Service Repair Manual

This manual is complements of
TrackLoaderParts.com

The world's best source for ASV parts.



Table of Contents

1. Product Safety		
Chapter Overview	1-1	
Safety Messages.....	1-1	
Information Messages	1-1	
Basic Precautions	1-1	
Safety Signs.....	1-1	
Protective Equipment.....	1-2	
Mounting and Dismounting	1-2	
Lifting	1-2	
Hot Fluids and Parts	1-2	
Corrosion Inhibitor	1-2	
Batteries	1-2	
Pressurized Items	1-2	
Repair	1-3	
Attachments	1-3	
Asbestos Information	1-4	
Machine Labels and Decals	1-4	
Product ID Number	1-4	
Machine Label and Decal Examples.....	1-5	
2. Technical Specifications		
PT-50 Specifications	2-1	
Engine	2-1	
Transmission	2-1	
Drive Motors	2-1	
Control Handles	2-1	
Auxiliary Pump.....	2-1	
Loader Valve.....	2-1	
Cooler	2-1	
Critical Torque Specifications	2-1	
PT-60 Specifications	2-2	
Engine	2-2	
Transmission	2-2	
Drive Motors	2-2	
Control Handles	2-2	
Auxiliary Pump.....	2-2	
Loader Valve.....	2-2	
Cooler	2-2	
Critical Torque Specifications	2-2	
3. System Diagrams		
Chapter Overview	3-1	
Filtering and Cooling System	3-1	
Auxiliary Circuit System (PT-50/60)	3-2	
Drive Loop System (PT-50/60).....	3-3	
Electrical Attachment Outlet (PT-50/60).....	3-4	
4. Machine Controls and Instrumentation		
Chapter Overview	4-1	
Machine Controls	4-1	
Loader Control	4-1	
Drive Control.....	4-1	
Throttle	4-1	
Instrumentation	4-1	
Switches.....	4-2	
5. Operator Enclosure Disassembly and Assembly		
Chapter Overview	5-1	
Personal Safety.....	5-1	
Machine Preparation	5-1	
Preliminary Checkout	5-1	
Operator Enclosure Disassembly and Assembly Procedures.....	5-1	
Light Bar Removal and Installation	5-1	
Light Bar Removal	5-1	
Light Bar Installation	5-2	
Ignition Switch Removal and Installation.....	5-2	
Ignition Switch Removal	5-2	
Ignition Switch Installation	5-3	
Gauge Removal and Installation	5-4	
Gauge Removal.....	5-4	
Gauge Installation.....	5-4	
Lap Bar Gas Assist Spring Removal and Installation.....	5-5	
Lap Bar Gas Assist Spring Removal	5-5	
Lap Bar Gas Assist Spring Installation	5-5	
6. Chassis Disassembly and Assembly		
Chapter Overview	6-1	
Personal Safety.....	6-1	
Machine Preparation	6-1	
Preliminary Checkout	6-1	
Chassis Disassembly and Assembly Procedures.....	6-1	
Seat Removal and Installation	6-1	
Seat Removal	6-1	
Seat Installation	6-2	
Fuel Sending Unit Removal and Installation	6-2	
Fuel Sending Unit Removal	6-3	
Fuel Sending Unit Installation	6-3	
7. Radiator/Oil Cooler Disassembly and Assembly		
Chapter Overview	7-1	
Personal Safety.....	7-1	
Machine Preparation	7-1	
Preliminary Checkout	7-1	
Radiator/Oil Cooler Disassembly and Assembly Procedures.....	7-1	
Fan Guard Removal and Installation.....	7-1	
Fan Guard Removal	7-2	
Fan Guard Installation	7-2	
Radiator/Cooler Removal and Installation.....	7-2	
Radiator/Cooler Removal	7-2	
Radiator/Cooler Installation	7-4	

8. Hydraulic Reservoir Disassembly and Assembly

Chapter Overview8-1
Personal Safety.....8-1
Machine Preparation8-1
Preliminary Checkout8-1
Hydraulic Reservoir Disassembly and Assembly Procedures.....8-1
Filter Assembly Removal and Installation8-1
 Filter Manifold Removal8-2
 Filter Manifold Installation8-2
Access Cover Removal and Installation8-2
 Access Cover Assembly Removal8-2
 Access Cover Assembly Installation8-3
Reservoir Gauge Removal and Installation8-3
 Reservoir Gauge Removal8-3
 Reservoir Gauge Installation8-4
Suction Screen Removal and Installation8-4
 Suction Screen Removal8-5
 Suction Screen Installation8-5
Hydraulic Reservoir Cleaning Procedures8-6
 Hydraulic Reservoir Cleaning8-6

9. Loader/Transmission Controls Disassembly and Assembly

Chapter Overview9-1
Personal Safety.....9-1
Machine Preparation9-1
Preliminary Checkout9-1
Loader/Transmission Controls Disassembly and Assembly Procedures9-1
Joystick Removal and Installation9-1
 Joystick Removal9-2
 Joystick Installation9-3
Loader Float Magnet Removal and Installation9-3
 Loader Float Magnet Removal9-3
 Loader Float Magnet Installation9-4
Loader Valve Removal and Installation9-4
 Loader Valve Removal9-4
 Loader Valve Installation9-6
Self Level Valve Removal and Installation9-6

10. Transmission and Drive Disassembly and Assembly

Chapter Overview10-1
Personal Safety.....10-1
Machine Preparation10-1
Preliminary Checkout10-1
Hydrostatic and Hydraulic Pump Disassembly and Assembly Procedures10-1
Auxiliary Gear Pump Removal and Installation10-1
 Auxiliary Gear Pump Removal10-1
Tandem Pump Removal and Installation10-3
 Tandem Pump Removal10-3
 Tandem Pump Installation10-4
Pump Drive Coupler Removal and Installation10-5
 Pump Drive Coupler Removal10-5
 Pump Drive Coupler Installation10-6

11. Undercarriage Disassembly and Assembly

Chapter Overview11-1
Personal Safety.....11-1
Machine Preparation11-1

Preliminary Checkout11-1
Undercarriage Disassembly and Assembly Procedures.....11-1
Center Wheel Removal and Installation11-1
 Wheel Removal11-2
 End Wheel Removal and Installation11-3
 End Wheel Removal11-3
 End Wheel Installation11-3
Sprocket Roller Removal and Installation11-4
Track Removal and Installation11-4
 Track Removal11-4
 Track Installation11-4
Outboard Bearing Removal and Installation11-5
 Bearing Removal11-5
 Bearing Installation11-5
Drive Sprocket Removal and Installation11-6
 Sprocket Removal11-6
 Sprocket Installation11-6
Drive Motor Removal and Installation11-6
 Drive Motor Removal11-6
 Drive Motor Installation11-6
Idle Wheel Hub Service Procedures11-7
 Disassembly Procedure11-7
 Assembly Procedure11-9

12. Loader Disassembly and Assembly

Chapter Overview12-1
Personal Safety.....12-1
Machine Preparation12-1
Preliminary Checkout12-1
Loader Disassembly and Assembly Procedures..12-1
Lift Cylinder/Tilt Cylinder Removal and Installation12-1
 Lift Cylinder/Tilt Cylinder Removal12-1
 Lift Cylinder/Tilt Cylinder Installation12-3
Q/C Block Relief Valve Removal and Installation..12-3
 Q/C Block Relief Valve Removal12-3
 Q/C Block Relief Valve Installation12-4

13. Maintenance

Chapter Overview13-1
Maintenance Schedule13-1
Engine Oil13-1
 Oil Change Procedures13-1
 Engine Oil Specifications13-1
Hydraulic Fluid and Filter13-2
 Hydraulic Fluid and Filter Change Procedures13-2
Fuel/Water Separator13-3
Fuel Filter13-3
 Fuel Filter Change Procedures13-3
 Fuel Specifications13-3
Air Cleaner13-3
 Air Filter Change Procedures13-3
Track Tension13-4
 Track Tension Adjustment Procedures13-4
 Checking for Proper Track Adjustment13-4
Fuse Box13-5
Grease Fittings13-5
Bleeding the Fuel System13-6

14. Hydraulic Pressure Check & Adjustment

Chapter Overview 14-1
Personal Safety..... 14-1
Machine Preparation 14-1
Hydraulic Pressure Adjustment Procedures..... 12-1
Charge Pressure check..... 14-1
Charge Pressure Adjustment..... 14-2
Auxiliary Pressure Check & Adjustment..... 14-2

15. Troubleshooting

Chapter Overview 15-1
Personal Safety..... 15-1
Machine Preparation 15-1
Preliminary Checkout 15-1
 Visual Inspection..... 15-1
Troubleshooting Scenarios..... 15-2

1. Product Safety

Chapter Overview

This chapter contains product safety information for the PT-50/60 Rubber Track Loaders. Read this chapter and understand all safety messages and information messages before attempting to service the machine.

Safety Messages

Safety messages are provided in this document and on the machine. If these hazard warnings are not heeded, bodily injury or death could occur to you or other persons.

Hazards are identified by the Safety Alert Symbols **!DANGER! . . . !WARNING!.....!CAUTION!**.

The meaning of these safety alerts is as follows:
Attention! Become Alert! Your Safety is Involved.

The message that appears under a Safety Alert Symbol explains the hazard and can be either written or pictorially presented.

! DANGER !

This symbol is used to alert service personnel of an imminently hazardous situation that will result in serious injury or death.

! WARNING !

This symbol is used to alert service personnel of a potentially hazardous situation that could result in serious injury or death.

! CAUTION !

This symbol is used to alert service personnel of an unsafe practice that could result in injury.

Information Messages

Information messages are provided in this document and on the machine. These messages are identified by the labels **NOTICE.....Note**.

NOTICE

This label is used to alert service personnel to the possibility of damaging the equipment.

Note: This label is used to provide important additional information, comments, explanations or amplification of the accompanying subject matter.

The person servicing the Rubber Track Loader may be unfamiliar with many of the systems on the machine. This makes it important to use caution when performing service work. Knowledge of the system and/or components is important before the removal or disassembly of any component.

It is not possible to anticipate every circumstance that might involve a potential hazard. The safety messages in this document and on the product are, therefore, not all-inclusive. If you use a tool, procedure, work method or operating technique that is not specifically recommended by the manufacturer, you must satisfy yourself that it is safe for you and for others. You should also ensure that the product will not be damaged or be made unsafe by the operation, lubrication, maintenance or repair procedures that you choose.

Basic Precautions

! WARNING !

Improper operation, lubrication, maintenance or repair of this product can be dangerous and could result in injury or death.

Do not operate or perform any lubrication, maintenance or repair on this product until you have read and understood the operation, lubrication, maintenance and repair information.

Following is a list of basic precautions that should always be observed.

Safety Signs

Read and understand all "Safety" signs on the product before operating, lubricating or repairing this product. Replace any damaged, illegible or missing safety plates, signs or decals.

1. Product Safety

Protective Equipment

Always wear a hard hat, protective glasses, protective shoes and other protective equipment as required by job conditions when working around this product. In particular, wear protective glasses when pounding on any part of the product or its attachment with a hammer or sledge. Use welders gloves, hood/goggles, apron and other protective clothing appropriate to the welding job being performed. Do not wear loose clothing or jewelry that can catch on parts of the product.

Mounting and Dismounting

Use steps and handholds when mounting or dismounting a machine. Clean any mud or debris from steps or work platforms before using them. Always face the machine when using steps and handholds. When it is not possible to use the designed access system, provide ladders, scaffolds, or work platforms to perform safe repair operations.

Lifting

Use a hoist when lifting components that weigh 23 kg (50 lb) or more, to avoid back injury. Make sure all chains, hooks, slings, etc., are in good condition and are of the correct capacity. Be sure hooks are positioned correctly and equipped with a spring latch. Lifting eyes are not to be side loaded during a lifting operation.

Hot Fluids and Parts

To avoid burns, be alert for hot parts on machines that have just been stopped and hot fluids in lines, tubes and compartments.

Be careful when removing fill caps, breathers and plugs on the machine. Hold a rag over the cap or plug to prevent being sprayed or splashed by liquids under pressure. The danger is even greater if the machine has just been stopped because fluids can be hot.

Corrosion Inhibitor

Corrosion inhibitor contains alkali. Avoid contact with eyes. Avoid prolonged or repeated contact with skin. Do not take internally. In case of contact, wash skin immediately with soap and water. For eyes, flush with large amounts of water for at least 15 minutes.

Call Physician. Keep out of reach of children.

Batteries

Do not smoke when inspecting the battery electrolyte level. Never disconnect any charging unit circuit or battery circuit cable from the battery when the charging unit is operating. A spark can cause an explosion from the flammable vapor mixture of hydrogen and oxygen that is released from the electrolyte through the battery outlets. Do not let electrolyte solution make contact with skin or eyes. Electrolyte solution is an acid. In case of contact, immediately wash skin with soap and water. For eyes, flush with large amounts of water for at least 15 minutes. **Call Physician. Keep out of reach of children.**

Pressurized Items

1. Always use a board or a piece of cardboard when you check for a leak. Leaking fluid under pressure can penetrate body tissue. Fluid penetration can cause serious injury and possible death. A pinhole leak can cause severe injury. If fluid is injected into your skin, get treatment immediately. Seek treatment from a doctor that is familiar with this type of injury.
2. Relieve all pressure in air, oil or water systems before disconnecting or removing any lines, fittings or related items. Always make sure all raised components are blocked correctly and be alert for possible pressure when disconnecting any device from a system that utilizes pressure.
3. Lower the bucket, blade, or other attachment to the ground before performing any work on the machine. If this cannot be done, make sure the bucket, blade, or other attachment is blocked correctly to prevent it from dropping unexpectedly.
4. Loose or damaged fuel, lubricant and hydraulic lines, tubes and hoses can cause fires. Do not bend or strike high-pressure lines or install ones that have been bent or damaged. Check lines, tubes and hoses carefully. Do not use your bare hand to check for leaks.
5. Pressurized air or water can cause personal injury. When pressurized air or water is used for cleaning, wear a protective face shield, protective clothing, and protective shoes. The maximum air pressure for cleaning purposes must be below 205 kPa (30 psi). When using a pressure washer, keep in mind that nozzle pressures are very high, generally pressures are well above 13790 kPa (2000 psi). Follow all recommended practices provided by the pressure washer manufacturer.

Repair

! WARNING !

Accidental machine starting can cause injury or death to personnel working on the machine.

To avoid accidental machine starting, disconnect the battery cables from the battery and tape the battery clamps and remove the key.

Place a "Do Not Operate" tag prominently on the machine to inform personnel that the machine is being worked on.

1. Disconnect battery and discharge any capacitor before starting to work on the product. Attach a **Do Not Operate** tag in the Operator's Compartment.
2. If possible, make all repairs with the machine parked on a level, hard surface. Block the machine to prevent it from rolling while working on or under the machine.
3. Do not work on any machine that is supported only by lift jacks or a hoist. Always use blocks or jack stands to support the machine before performing any service or disassembly.
4. Make sure the work area around the product is made safe and be aware of hazardous conditions that may exist. If an engine is started inside an enclosure, make sure that the engine's exhaust is properly vented.
5. Be sure all protective devices including guards and shields are properly installed and functioning correctly before starting a repair. If a guard or shield must be removed to perform the repair work, use extra caution.
6. Always use tools that are in good condition and be sure you understand how to use them before performing any service work.
7. Replace all fasteners with the same part number. Do not use a lesser quality fastener if replacements are necessary.
8. Be prepared to stop an engine if it has been recently overhauled or the fuel system has been recently worked on. If the engine has not been assembled correctly, or if the fuel settings are not correct, the engine can possibly overspeed and cause bodily injury, death or property damage. Be prepared to shut off the fuel and air supply to the engine in order to stop the engine.
9. Be careful when removing cover plates. Gradually back off the last two bolts or nuts located at opposite ends of the cover or device. Then, pry the cover loose to relieve any spring or other pressure before removing the last two nuts or bolts completely.
10. Repairs requiring welding should be performed only with the benefit of the appropriate reference information and by personnel adequately trained and knowledgeable in welding procedures. Determine the type of metal being welded and select the correct welding procedures and electrodes, rods or wire to provide a weld metal equivalent at least to that of the parent weld.
11. Do not damage wiring during removal operations. Reinstall the wiring so it is not damaged during installation or operation by contacting sharp corners or by rubbing against some object or hot surface.
12. Always use lift arm supports to keep lift arms raised. Keep the attachment tilted down and assure that all hydraulic pressure has been relieved for maintenance or repair work that requires the lift arms to be in the raised position.
13. Tighten connections to the correct torque. Make sure that all heat shields, clamps and guards are installed correctly to avoid excessive heat, vibration or rubbing against other parts during operation. Shields that protect against oil spray onto hot exhaust components in event of a line, tube or seal failure must be installed correctly.
14. Do not operate a machine if any rotating part is damaged or contacts another part during operation. Any high-speed rotating component that has been damaged or altered should be checked for balance before reusing. Make sure all protective devices, including guards and shields, are properly installed and functioning correctly before starting the engine or operating the machine.

Attachments

Only use attachments that are recommended by the manufacturer of the machine.

Make sure that all necessary guarding is in place on the host machine and on the attachment.

Wear protective glasses and protective equipment as required by conditions or as recommended in the attachment's operation manual.

1. Product Safety

Ensure that all personnel are far enough away from the work area so they will not be struck by flying objects.

Stay clear of the cutting edges, pinching surfaces or crushing surfaces of the attachment while performing any attachment maintenance, testing or adjustments.

Asbestos Information

Equipment and replacement parts shipped from the manufacturer are asbestos free. When replacement parts are required, use only genuine manufacturer's replacement parts

Use caution when handling replacement parts from another supplier if these parts contain asbestos. Avoid inhaling dust that might be generated when handling these components or when handling asbestos debris. Inhaling this dust can be hazardous to your health.

The components that may contain asbestos fibers are lining material, and some gaskets. The asbestos that is used in these components is usually encased in a resin or sealed in some way. Normal handling is not hazardous unless airborne dust containing asbestos is generated.

If dust that may contain asbestos is present, there are several guidelines that should be followed.

1. Never use compressed air for cleaning. Avoid brushing or grinding materials that contain asbestos. Use a wet method to clean up asbestos debris. A vacuum that is equipped with the high-efficiency particulate air filter (HEPA filter) can also be used.
2. Use exhaust ventilation on permanent machining jobs.
3. Wear an approved respirator if there is no other way to control the dust.
4. Comply with applicable rules and regulations for the work place. In the USA, use Occupational Safety and Health Administration requirements. These OSHA requirements can be found in 29 CFR 1910.1001.
5. Obey environmental regulations for disposal of asbestos.
6. Stay away from areas that might have asbestos particles in the air.

! WARNING !

When replacement parts are required for this product, use only genuine manufacturer's replacement parts or parts with equivalent specifications including, but not limited to physical dimensions, type, strength and material.

Failure to heed this warning can lead to premature failures, product damage, personal injury or death.

Machine Labels and Decals

Labels and decals placed on the machine provide safety information and operating instructions. Make sure you know the location of these labels and understand their significance.

Product ID Number

The product ID number (PIN) is located on the left side of the firewall (Figure 1-1). Always provide the PIN when contacting the dealer about parts, service, warranty or accessories. No warranty claims will be processed unless the PIN is provided.



Figure 1-1

1-001

Machine Label and Decal Examples

Examples of the labels and decals placed on the machine are shown on this page.



2. Technical Specifications

PT-50 Specifications

Engine

- Model: Perkins 404C-22
- Displacement: 2.2 liter
- Gross horsepower: 50 hp, 37.3 kW
- Torque: 105 lb-ft. 143 Nm
- Idle rpm: 2800 (high idle); 1175 (low idle)
- Average water /thermostat temperature: 190°F, 87.8°C

Transmission

- Model: A22 (38.5cc) tandem (Rexroth)

Drive pumps

- Displacement: 2.349 in³/rev (38.5 cc/rev)
- Relief pressure: 5500 psi, 380 bar
- Flow: 28 gpm (106 lpm) @ 2800 rpm (high idle)

Charge pump

- Displacement: 1.098 in³/rev (18 cc/rev)
- Relief pressure: 400-450 psi

Drive Motors

- Model: Rexroth MCR 05C
- Displacement: 37.8 in³/rev (620 cc/rev)

Control Handles

- Model: 4TH6 (Rexroth)

Auxiliary Pump

- Make: Haldex-Barnes #180-2061
- Displacement: 1.343 in³/rev (22 cc/rev)
- Flow: 16.27 gpm (61.85 lpm) @ 2800 rpm (high idle)
- Relief pressure: 3000 psi (20,684 kPa)
- Cooling/filtering: Auxiliary oil is filtered and cooled at all times. In Auxiliary mode, the oil is filtered after the attachment to protect the machine if the attachment motor fails or contaminants are introduced from the quick couplers.

Loader Valve

- Model: Husko
- Relief pressure: 3000 psi (20,684 kPa)
- Pilot pressure required to move spools: 180-220 psi (1241-1517 kPa)

Cooler

- Burst pressure: 400 psi (2757 kPa)
- Operating pressure: 250 psi (1724 kPa)
- Bypass relief pressure: 80 psi (689 kPa)
- Hot oil sending unit: 225°F (107.2°C)

Critical Torque Specs

- Transmission Mounting Bolts
 - o 85 ft-lb. w/Blue Loctite
- Drive Sprocket Drive Teeth Bolts
 - o 88 ft-lb. -Dry
- Center Bogie Wheel Retaining Nut
 - o 111 ft-lb. -Dry
- End Wheel Axle Retaining Nut
 - o 300 ft-lb. -Dry
- Drive Sprocket Lug Nut
 - o 129 ft-lb. -Dry
- Drive Motor Mounting Bolts
 - o 177 ft-lbs. -Dry

PT-60 Specifications

Engine

- Model: Perkins 404C-22T
- Displacement: 2.2 liter
- Gross horsepower: 60 hp, 44.7 kW
- Torque: 140 lb-ft. 190 Nm
- Idle rpm: 2800 (high idle); 1175 (low idle)
- Average water /thermostat temperature: 190°F, 87.8°C

Transmission

- Model: A22 (38.5cc) tandem (Rexroth)

Drive pumps

- Displacement: 2.349 in³/rev (38.5 cc/rev)
- Relief pressure: 5500 psi, 380 bar
- Flow: 28 gpm (106 lpm) @ 2800 rpm (high idle)

Charge pump

- Displacement: 1.098 in³/rev (18 cc/rev)
- Relief pressure: 400-450 psi

Drive Motors

- Model: Rexroth MCR 5 (2-speed)
- Displacement: 50 in³/rev (820 cc/rev)

Control Handles

- Model: 4TH6 (Rexroth)

Auxiliary Pump

- Make: Haldex-Barnes #180-2061
- Displacement: 1.343 in³/rev (22 cc/rev)
- Flow: 16.27 gpm (61.85 lpm) @ 2800 rpm (high idle)
- Relief pressure: 3000 psi (20,684 kPa)
- Cooling/filtering: Auxiliary oil is filtered and cooled at all times. In Auxiliary mode, the oil is filtered after the attachment to protect the machine if the attachment motor fails or contaminants are introduced from the quick couplers.

Loader Valve

- Model: Husko
- Relief pressure: 3000 psi (20,684 kPa)
- Pilot pressure required to move spools: 180-220 psi (1241-1517 kPa)

Cooler

- Burst pressure: 400 psi (2757 kPa)
- Operating pressure: 250 psi (1724 kPa)
- Bypass relief pressure: 80 psi (689 kPa)
- Hot oil sending unit: 225°F (107.2°C)

Critical Torque Specs

- Transmission Mounting Bolts
 - o 85 ft-lb. w/Blue Loctite
- Drive Sprocket Drive Teeth Bolts
 - o 88 ft-lb. -Dry
- Center Bogie Wheel Retaining Nut
 - o 111 ft-lb. -Dry
- End Wheel Axle Retaining Nut
 - o 300 ft-lb. -Dry
- Drive Sprocket Lug Nut
 - o 129 ft-lb. -Dry
- Drive Motor Mounting Bolts
 - o 177 ft-lbs. -Dry

3. System Diagrams

Chapter Overview

This chapter contains diagrams for the following PT-50/60 systems.

- Filtering and cooling system
- Auxiliary circuit system
- Drive loop system

Figure 3-1

Filtering and Cooling System

The filtering and cooling system (Figure 3-1) contains the following major components.

- Hydraulic reservoir
- Radiator/oil cooler
- Loader valve

PT-50/60 Filtering and Cooling System

3-001

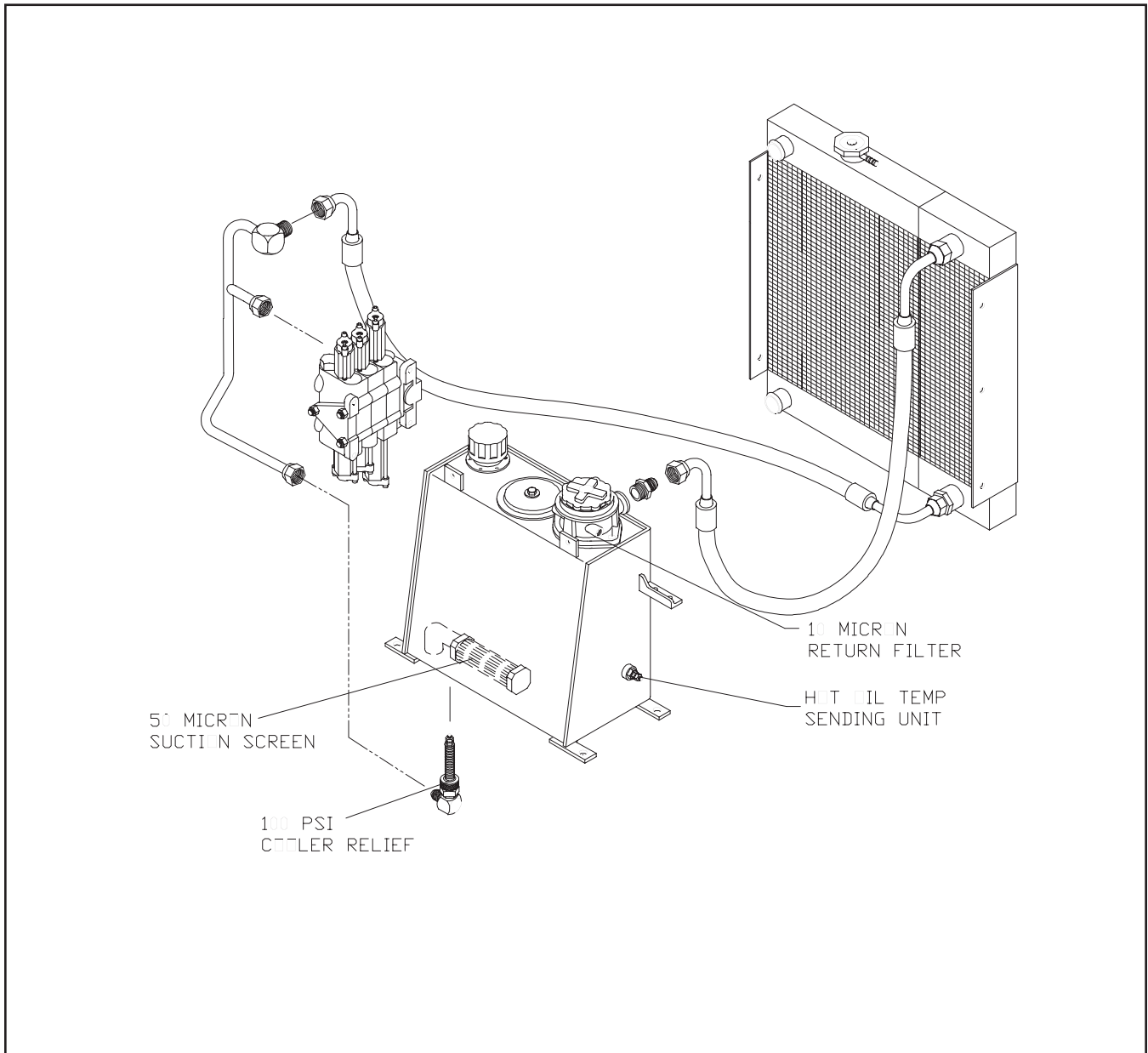

Auxiliary Circuit System

The auxiliary circuit system (fig. 3-2) contains the following major components.

- Loader valve
- Pilot control manifold
- Auxiliary gear pump
- Loader control joystick

Figure 3-2

PT-50/60 Auxiliary Circuit System

3-002

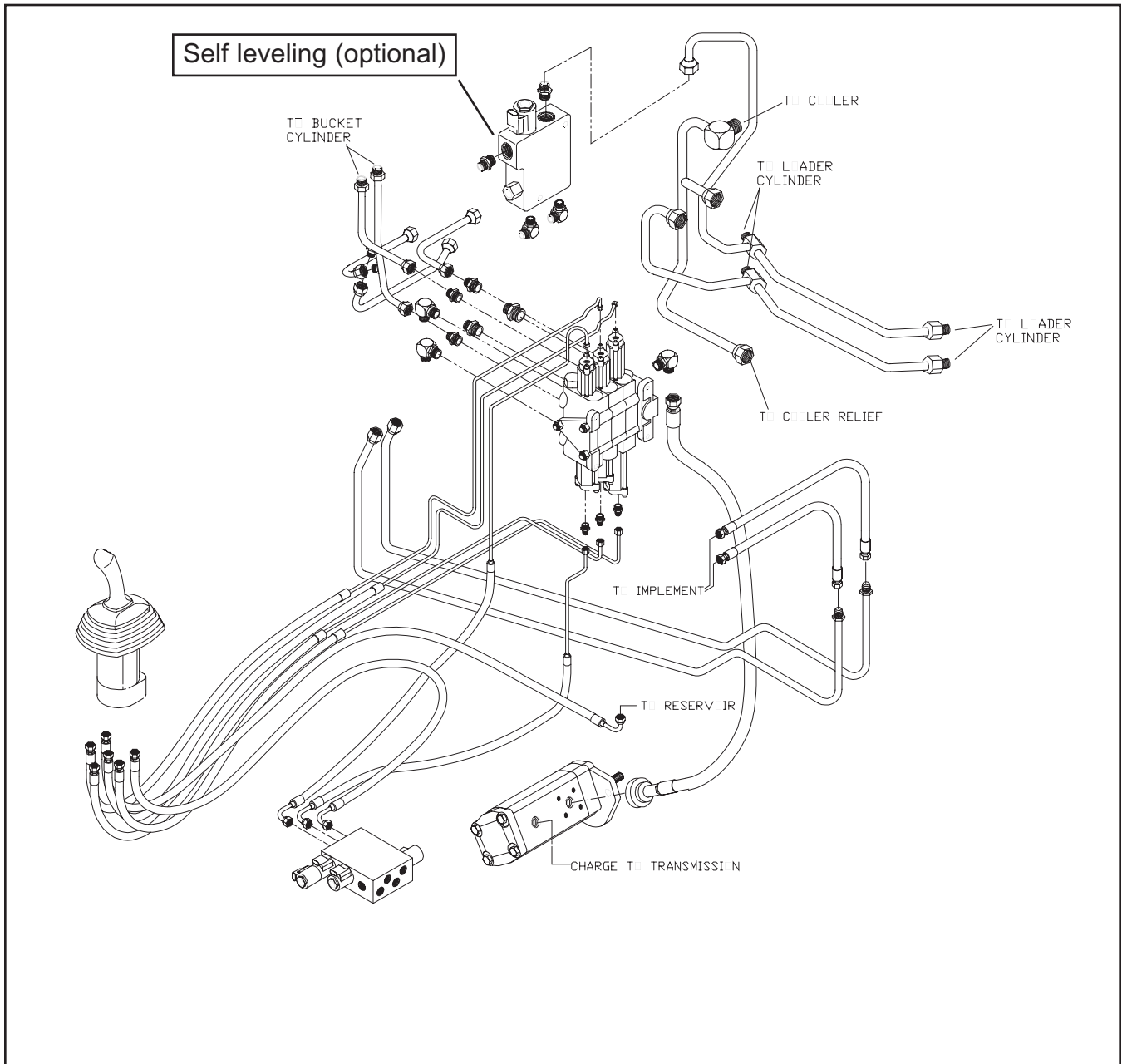

Drive Loop System

The drive loop system (fig. 3-3) contains the following major components.

- Drive motors
- Pilot control manifold
- Drive control joystick
- Tandem pump

Figure 3-3

PT-50/60 Drive Loop System

3-003

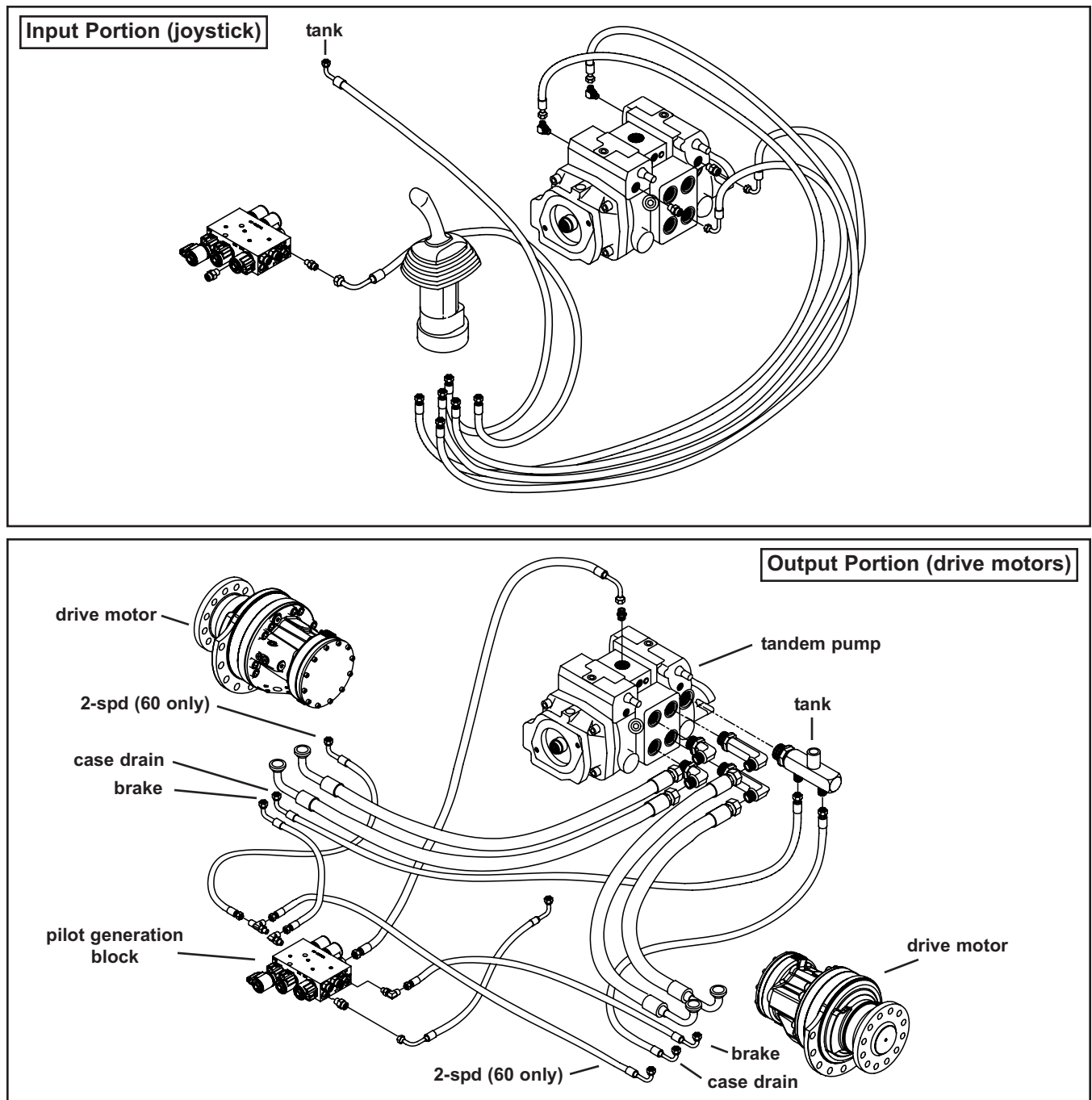

Electrical Attachment Outlet

Figure 3-4 PT-50/60 Electrical Attachment Outlet

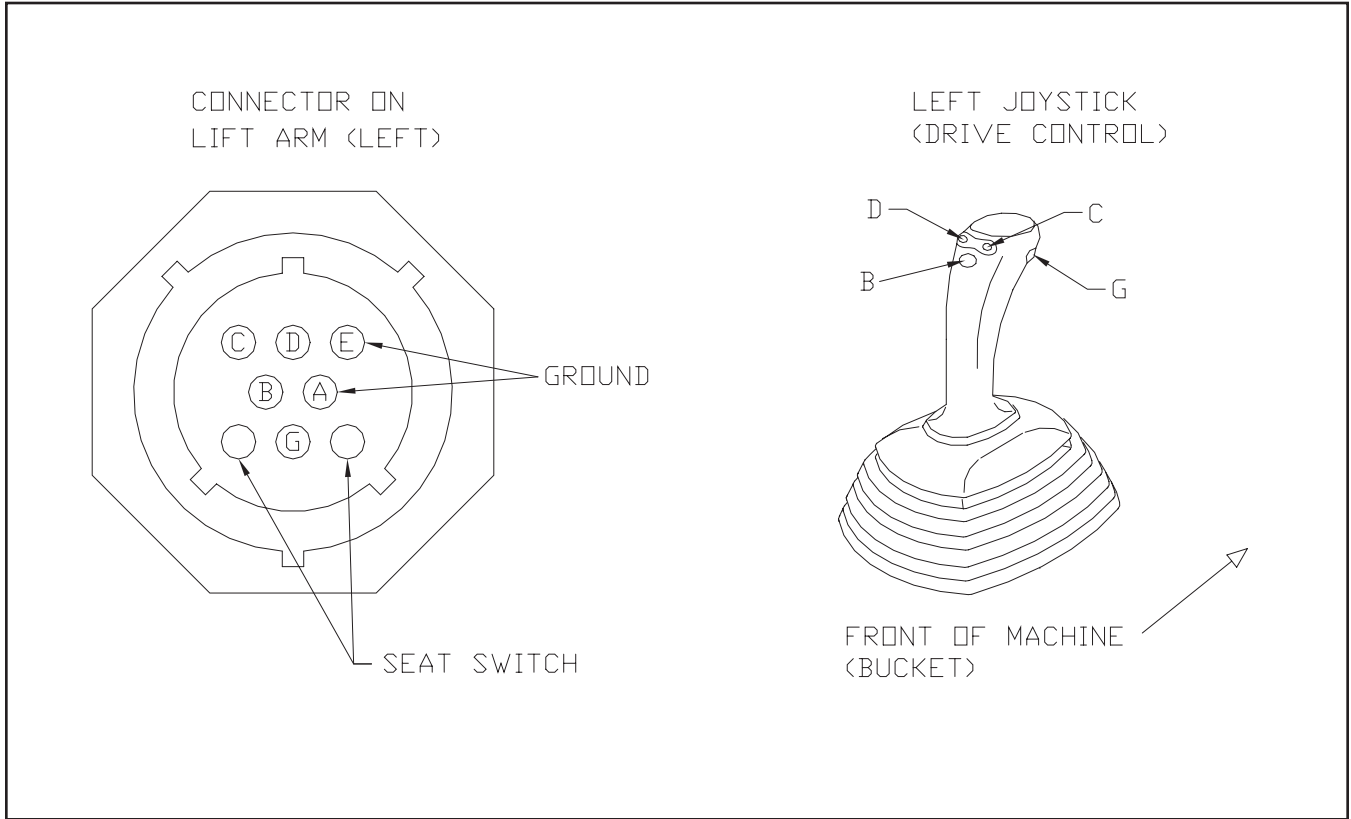

4. Machine Controls and Instrumentation

Chapter Overview

This chapter contains an overview of the machine controls and instrumentation. For further information regarding machine controls, instrumentation or operation, refer to the operation and maintenance manual for the PT-50 & 60 machines. Included here are illustrations of the following controls and instrumentation components and a description of their functions.

- Machine Controls
- Instrument Location and Function
- Switch Location and Function

Machine Controls (fig. 4-1)

There are three primary machine controls: loader control (1), drive control (2) and throttle (3).

Loader Control

The loader control (1) is a pilot operated joystick that allows the operator to raise or lower the loader and dump or curl the quick attach mechanism.

Drive Control

The drive control (2) is also a pilot operated joystick. It allows the operator to change the direction and speed of the machine.

Throttle

The foot throttle (3) controls engine rpm.

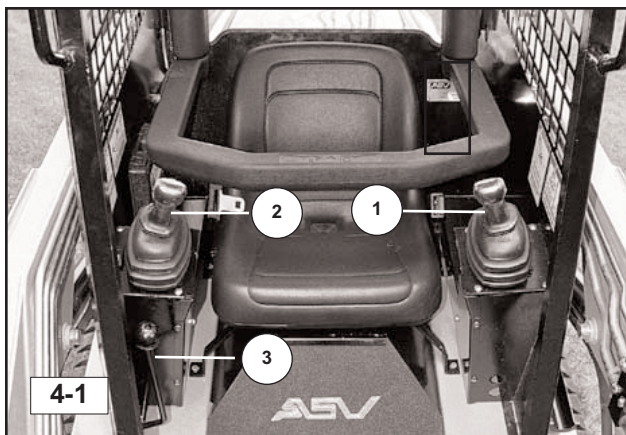

Note: The PT 50/60 machines are also equipped with a foot throttle mechanism. To use, simply press the pedal until the desired RPM is reached. To hold that RPM, pivot the hand lever forward until it contacts the pedal, then release. Pull back on hand lever to decrease RPM.

Instrumentation

The Instruments (Figure 4-2) are positioned in the overhead dash panel for ease of access and visibility when seated inside the operator enclosure. Instruments include the following components.

- (1) Fuel Level Gauge
- (2) Warning Indicator Display
 - Engine Oil Pressure Warning Light
 - Engine Temperature Warning Light
 - Hydraulic Oil Temperature Warning Light
 - Battery Voltage Warning Light
- (3) Hour Meter
- (4) Tachometer (optional PT-50)
- (5) Engine Temperature Gauge (optional PT-50)

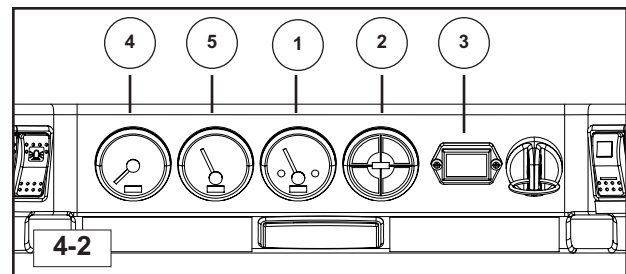

NOTICE

Should the optional engine temperature gauge read excessive temperatures (**or** warning light illuminate) or should the oil pressure or hydraulic oil temperature lights illuminate during normal machine operation, shut the machine down immediately. Diagnose the problem and make any necessary repairs before resuming normal operation.

NOTICE

If the battery low-voltage light should illuminate during operation, drive the machine to a suitable location and shut the engine off. Diagnose the problem and make any needed repairs before resuming operation.

The glow plug operation light illuminates only when the key switch is turned to engine pre-heat, showing normal operation.

Switches

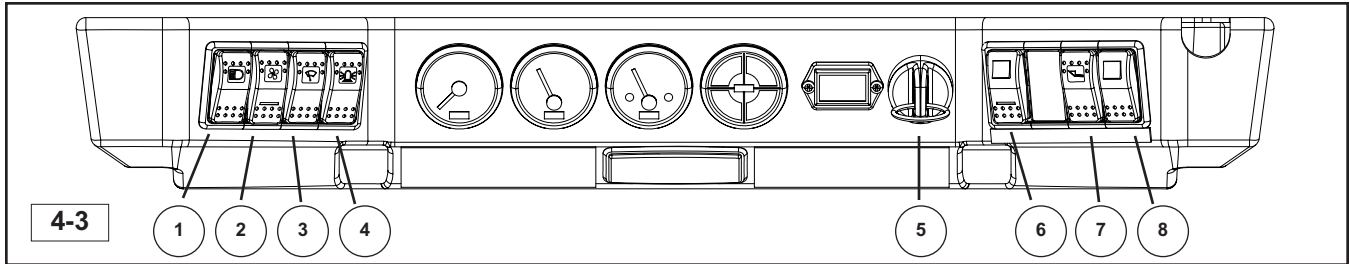

The various switches (Figure 4-3) are positioned to provide good access and visibility. The standard and optional switches are listed below.

- (1) Lights (front and rear)
- (2) Heater Fan (optional)
- (3) Wiper (optional)
- (4) Beacon (optional)
- (5) Ignition, glow plug (pre-heat)
- (6) Auxiliary Hydraulics
- (7) Bucket Positioning (optional)
- (8) Power Quick Attach (optional)

5. Operator Enclosure Disassembly and Assembly

Chapter Overview

This chapter provides disassembly and assembly procedures for the operator enclosure assembly.

Personal Safety

! WARNING !

Improper operation, lubrication, maintenance or repair of this product can be dangerous and could result in injury or death.

Do not operate or perform any lubrication, maintenance or repair on this product until you have read and understood the operation, lubrication, maintenance and repair information.

Before starting any disassembly or assembly procedures, refer to *Chapter 1. Product Safety – Basic Precautions* for personal safety information.

Machine Preparation

! WARNING !

Accidental machine starting can cause injury or death to personnel working on the machine.

To avoid accidental machine starting, disconnect the battery cables from the battery and tape the battery clamps and remove the key.

Place a “Do Not Operate” tag prominently on the machine to inform personnel that the machine is being worked on.

Before starting any disassembly or assembly procedures, refer to *Chapter 1. Product Safety – Repair* for machine preparation information.

Preliminary Checkout

If troubleshooting is required prior to disassembly or assembly, refer to *Chapter 15. Troubleshooting*.

Operator Enclosure Disassembly and Assembly Procedures

Disassembly and assembly procedures are provided for the following operator enclosure components.

- Light Bar
- Ignition Switch
- Gauges
- Lap Bar Gas Assist Spring

Note: Procedures are provided for only those operator enclosure components listed above. However, information for removal and installation of other operator enclosure components can be obtained from the Rubber Track Loader Parts manual.

Light Bar Removal and Installation

The tools required for light bar console removal and installation are listed in Table 5-1. Use manufacturer-recommended tools whenever possible.

Table 5-1

Required Tools
Combination Wrench

Light Bar Removal



Figure 5-1

5-001

1. Loosen the two capscrews that attach the light bar to the cab frame.

5. Operator Enclosure Disassembly and Assembly



Figure 5-2

5-002

2. Carefully lower the light bar with the wire harness attached.



Figure 5-3

5-003

3. View of light bar interior components. Interior components are now accessible for servicing.



Figure 5-4

5-004

4. View of dome light. If removal is required, simply insert a lever (blade-type screw driver) at opposite end of switch in pry-pocket, and gently pry the light assembly out of the light bar.

Light Bar Installation



Figure 5-5

5-005

1. Carefully position the light bar, without pinching the wiring harness against the cab roof.



Figure 5-6

5-006

2. Secure the light bar to the cab roof with the two capscrews

Ignition Switch Removal and Installation

The tools required for ignition switch removal and installation are listed in Table 5-2. Use manufacturer-recommended tools whenever possible.

Table 5-2

Required Tools
Combination Wrench

Ignition Switch Removal

1. Lower the light bar. Refer to *Chapter 5. Light Bar Removal* procedure.

5. Operator Enclosure Disassembly and Assembly



Figure 5-7 5-007

2. Remove the nut that secures the ignition switch to the dash panel.



Figure 5-8 5-008

3. Pull the ignition switch out from the rear of the dash panel.



Figure 5-9 5-009

4. Unplug the ignition switch connector.

Ignition Switch Installation



Figure 5-10 5-010

1. Insert the ignition switch from the rear of the dash panel.



Figure 5-11 5-011

2. Install the nut that secures the ignition switch to the dash panel.



Figure 5-12 5-012

3. Plug in the ignition switch connector.

5. Operator Enclosure Disassembly and Assembly

4. Install the light bar. Refer to *Chapter 5. Light Bar Installation* procedure.

Gauge Removal and Installation

The tools required for gauge removal and installation are listed in Table 5-3. Use manufacturer-recommended tools whenever possible.

Table 5-3

Required Tools
Combination wrench

Gauge Removal

1. Lower the light bar. Refer to *Chapter 5. Light Bar Removal* procedure.

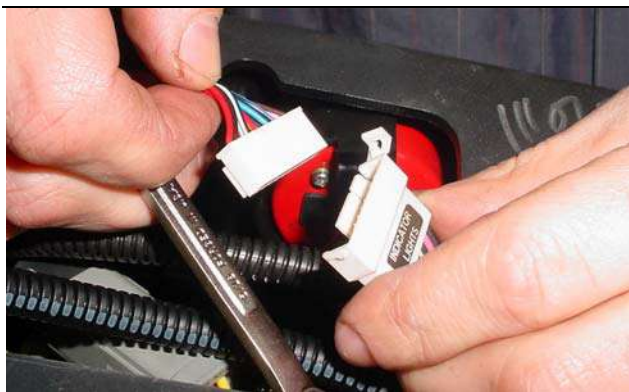

Figure 5-13

5-013

2. Disconnect the connector from the gauge.



Figure 5-14

5-014

3. Remove the two nuts that secure the gauge to the retaining bracket.



Figure 5-15

5-015

4. Pull the gauge out from the front of the dash panel.

Gauge Installation



Figure 5-16

5-016

1. Insert the gauge from the front of the dash panel.



Figure 5-17

5-017

2. Install the two nuts that secure the gauge to the retaining bracket.

5. Operator Enclosure Disassembly and Assembly



Figure 5-18

5-018

3. Reconnect the gauge connector.
4. Install the light bar. Refer to *Chapter 5. Light Bar Installation* procedure.

Lap Bar Gas Assist Spring Removal and Installation

The tools required for gas assist spring removal and installation are listed in Table 5-4. Use manufacturer-recommended tools whenever possible.

Table 5-4

Required Tools
Screwdriver

Lap Bar Gas Assist Spring Removal

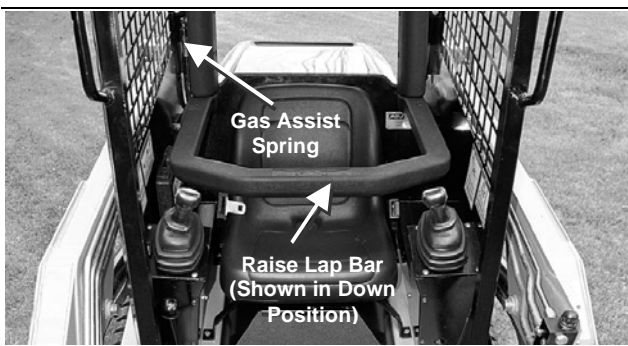

Figure 5-19

5-019

1. Put the lap bar in the UP position to relieve tension on the lap bar gas assist spring.

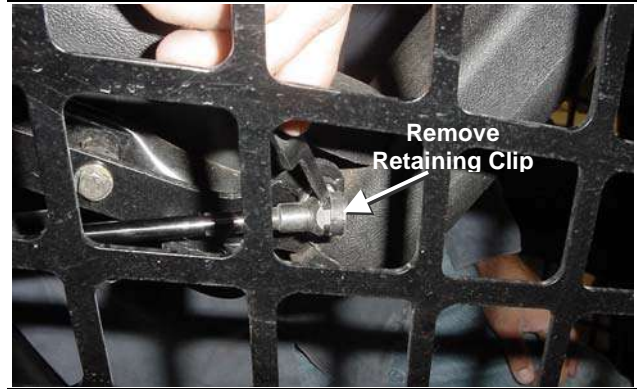

Figure 5-20

5-020

2. Using a small screwdriver, remove the retaining clip from each end of the gas assist spring.



Figure 5-21

5-021

3. Remove the gas assist spring by pulling both ends out from the ball joints.

Lap Bar Gas Assist Spring Installation



Figure 5-22

5-022

1. Put the lap bar in the UP position to minimize tension on the lap bar gas assist spring during installation.

5. Operator Enclosure Disassembly and Assembly

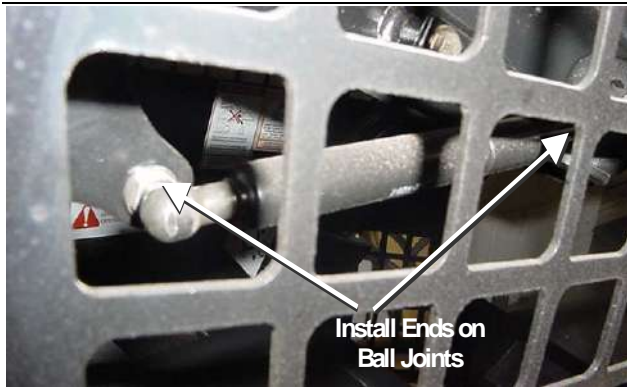

Figure 5-23

5-023

2. Install the ends of the lap bar gas assist spring onto the ball joints.

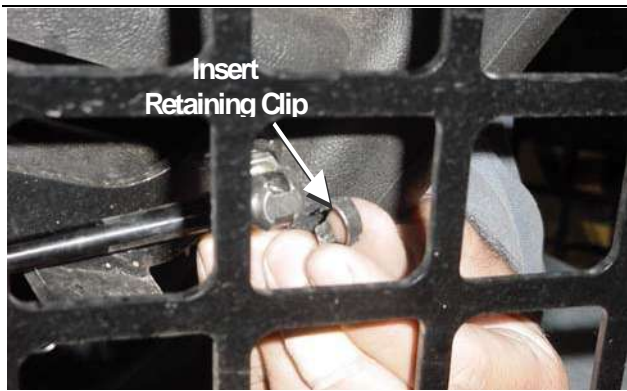

Figure 5-24

5-024

3. Slide the retaining clip on to each end of the gas assist spring.

6. Seat & Fuel Sender Disassembly and Assembly

Chapter Overview

This chapter provides disassembly and assembly procedures for the chassis assembly.

Personal Safety

! WARNING !

Improper operation, lubrication, maintenance or repair of this product can be dangerous and could result in injury or death.

Do not operate or perform any lubrication, maintenance or repair on this product until you have read and understood the operation, lubrication, maintenance and repair information.

Before starting any disassembly or assembly procedures, refer to *Chapter 1. Product Safety – Basic Precautions* for personal safety information.

Machine Preparation

! WARNING !

Accidental machine starting can cause injury or death to personnel working on the machine.

To avoid accidental machine starting, disconnect the battery cables from the battery and tape the battery clamps and remove the key.

Place a “Do Not Operate” tag prominently on the machine to inform personnel that the machine is being worked on.

Before starting any disassembly or assembly procedures, refer to *Chapter 1. Product Safety – Repair* for machine preparation information.

Preliminary Checkout

If troubleshooting is required prior to disassembly or assembly, refer to *Chapter 15. Troubleshooting*.

Chassis Disassembly and Assembly Procedures

Disassembly and assembly procedures are provided for the following chassis components.

- Seat
- Fuel Sending Unit
- Fuel Sending Unit Hose
- In-Tank Weight

Note: Procedures are provided for only those chassis components listed above. However, information for removal and installation of other chassis components can be obtained from the exploded view illustration provided in the Rubber Track Loader Parts manual.

Seat Removal and Installation

The tools required for seat removal and installation are listed in Table 6-1. Use manufacturer-recommended tools whenever possible.

Table 6-1

Required Tools
Socket Wrench

Seat Removal

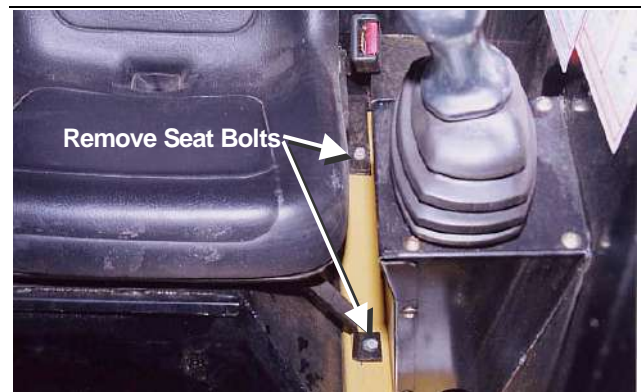

Figure 6-1

6-001

1. Remove the four nuts that fasten the seat mounts to the frame.

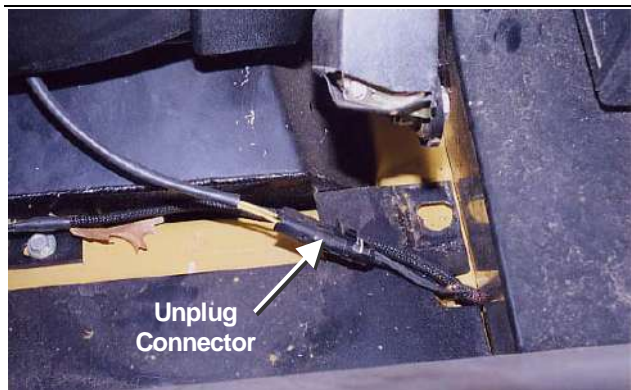

Figure 6-2 6-002

2. Tilt the seat forward and reach behind the seat to unplug the seat switch wiring harness.



Figure 6-3 6-003

3. Remove the seat. Be careful not to scratch the control panel or sides of the cab.

Seat Installation



Figure 6-4 6-003

1. With the seat mounts attached, place the seat in the cab. Be careful not to scratch the control panel or sides of the cab.

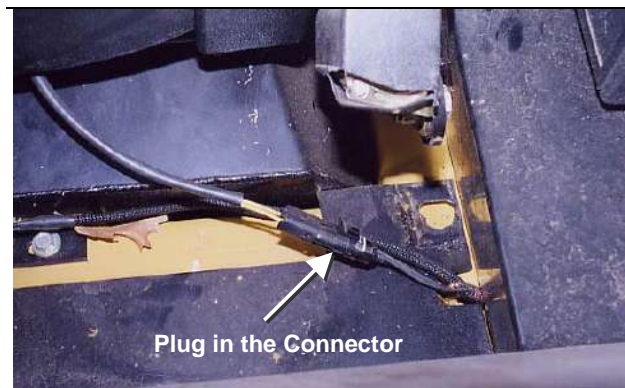

Figure 6-5 6-002

2. Tilt the seat forward and reach behind the seat to plug in the seat switch connector

Note: The machine will not operate unless the seat switch connector is plugged in.

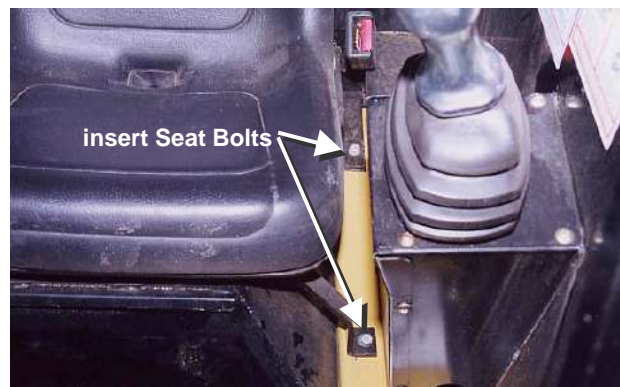

Figure 6-6 6-001

3. Position the seat so the holes in the seat mounts are aligned with the bolts in the frame. Install the four seat mount nuts and washers.

Fuel-Sending Unit Removal and Installation

The tools required for fuel sending unit removal and installation are listed in Table 6-2. Use manufacturer-recommended tools whenever possible.

Table 6-2

Required Tools
Screwdriver
Combination Wrench
Socket Wrench

Fuel Sending Unit Removal

1. Remove the seat. Refer to *Chapter 6. Seat Removal* procedure.
2. Pump fuel from the tank until there is no fuel remaining above the sending unit.

NOTICE

Collect and contain liquids in a suitable container. Dispose of all liquids according to local regulations and mandates.



Figure 6-7

6-004

3. Remove the hoses and wires from the fuel-sending unit, then remove the screws that fasten the unit to the tank. Mark the wires and hoses.

Note: If the fuel sending unit wires are crossed, the fuel gauge will not work. If the hoses are crossed, the engine will not run.



Figure 6-8

6-005

4. Remove the fuel-sending unit. Be careful not to damage the float mechanism when pulling it through the opening in the fuel tank.



Figure 6-9

6-006

5. The fuel pickup line will also come out with the fuel-sending unit.

Fuel Sending Unit Installation



Figure 6-10

6-006

1. Insert the fuel pickup line into the fuel tank opening. The pickup line is attached to the fuel-sending unit.

Note: The weight on the end of the fuel pickup line must rest on the bottom of the tank for proper operation.

2. Insert the fuel sending unit float mechanism into the fuel tank opening. Be careful not to damage the float when pushing it through the opening.

6. Chassis Disassembly and Assembly

Note: Make sure that the wire on the sending unit is not bent and the fuel pickup line does not interfere with the movement of the float.

3. Connect the hoses and wires to the fuel-sending unit, and then install the screws that fasten the unit to the tank.

Note: Be careful not to cross the wires or hoses. If the fuel sending unit wires are crossed, the fuel gauge will not work. If the hoses are crossed, the engine will not run.

4. Install the seat. Refer to *Chapter 6. Seat Installation* procedure.

7. Radiator/Oil Cooler Disassembly and Assembly

Chapter Overview

This chapter provides disassembly and assembly procedures for the radiator/oil cooler assembly. Adjustment procedures are also included for selected radiator/oil cooler components.

Personal Safety

! WARNING !

Improper operation, lubrication, maintenance or repair of this product can be dangerous and could result in injury or death.

Do not operate or perform any lubrication, maintenance or repair on this product until you have read and understood the operation, lubrication, maintenance and repair information.

Before starting any disassembly or assembly procedures, refer to *Chapter 1. Product Safety – Basic Precautions* for personal safety information.

Machine Preparation

! WARNING !

Accidental machine starting can cause injury or death to personnel working on the machine.

To avoid accidental machine starting, disconnect the battery cables from the battery, tape the clamps and remove the key.

Place a “Do Not Operate” tag prominently on the machine to inform personnel that the machine is being worked on.

Before starting any disassembly or assembly procedures, refer to *Chapter 1. Product Safety – Repair* for machine preparation information.

Preliminary Checkout

If troubleshooting is required prior to disassembly or assembly, refer to *Chapter 15. Troubleshooting*.

Radiator/Oil Cooler Disassembly and Assembly Procedures

Disassembly and assembly procedures are provided for the following radiator/oil cooler components.

- Fan Guard
- Radiator/Cooler

Note: Procedures are provided for only those radiator/oil cooler components listed above. However, information for removal and installation of other radiator/oil cooler components can be obtained from the Rubber Track Loader Parts manual.

Note: Refer to Figure 3-1 for an overview of the filtering and cooling system.

Fan Guard Removal and Installation

The tools required for fan guard removal and installations are listed in Table 7-1. Use manufacturer-recommended tools whenever possible.

Table 7-1

Required Tools
Combination Wrench

Fan Guard Removal



Figure 7-1

7-001

1. Remove the bolts that secure the fan guard to the fan shroud.
2. Remove the fan guard from the engine compartment.

Fan Guard Installation

1. Position the fan guard over the fan and against the fan shroud.
2. Install the capscrews that secure the fan guard to the fan guard mounts.

Radiator/Cooler Removal and Installation

The tools required for radiator/cooler removal and installations are listed in Table 7-2. Use manufacturer-recommended tools whenever possible.

Table 7-2

Required Tools
Combination Wrench
Socket Wrench
Screwdriver

Radiator/Cooler Removal

! WARNING !

Hot oil can cause personal injury. Make sure the oil is cool before removing any components or lines.

Remove the oil filler cap only when the engine is stopped and the machine has been allowed to cool thoroughly.

! WARNING !

Personal injury can result from hot coolant, steam and alkali.

At operating temperature, engine coolant is hot and under pressure. The radiator and all lines to the heaters and the engine contain hot coolant and steam. Contact can cause severe burns.

Remove the filler cap slowly to relieve pressure only when the engine is stopped and the machine has been allowed to cool thoroughly.

Do not attempt to tighten the hose connections when the coolant is hot. The hose can come off and cause burns.

Cooling system conditioner contains alkali. Avoid contact with skin and eyes.

NOTICE

Collect and contain liquids in a suitable container. Dispose of all liquids according to local regulations and mandates.

1. Drain the hydraulic fluid. Refer to *Chapter 13. Hydraulic Fluid and Filter Change.*



Figure 7-2 7-008

2. Drain the coolant using the petcock on the bottom of the radiator.



Figure 7-3 7-010

3. Remove the lower hose from the oil cooler section. Cap the hose and fitting.



Figure 7-4 7-002

4. Remove the upper hose from the oil cooler section. Cap the hose and fitting.

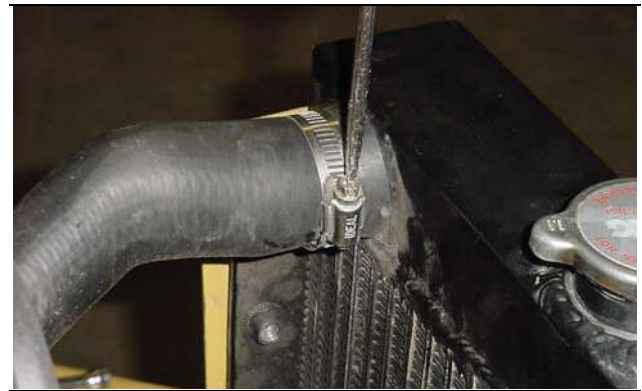

Figure 7-5 7-011

5. Remove the upper hose from the radiator section. Cap the hose and fitting.



Figure 7-6 7-012

6. Remove the lower hose from the radiator section. Cap the hose and fitting.

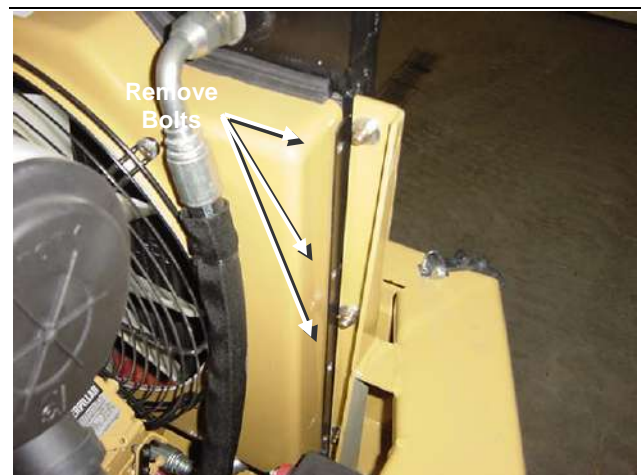

Figure 7-7 7-003

7. Remove the three mounting bolts on each side of the radiator/cooler.



Figure 7-8 7-013

8. Remove the radiator/cooler from the engine compartment.

Radiator/Cooler Installation



Figure 7-9 7-013

1. Install the engine shroud, and position the radiator/cooler in the engine compartment.



Figure 7-10 7-003

2. With the radiator/cooler in position, install the three mounting bolts on each side of the radiator/cooler.



Figure 7-11 7-012

3. Remove the hose and fitting caps and install the lower hose on the radiator section.

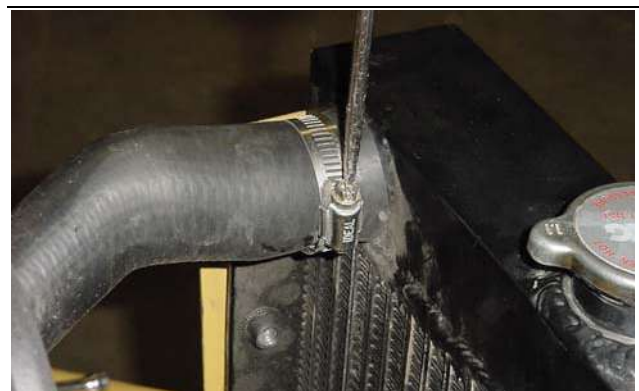

Figure 7-12 7-011

7. Radiator/Oil Cooler Disassembly and Assembly

4. Remove the hose and fitting caps and install the upper hose on the radiator section.



Figure 7-13

7-002

5. Remove the hose and fitting caps and install the upper hose on the oil cooler section.



Figure 7-14

7-010

6. Remove the hose and fitting caps and install the lower hose on the oil cooler section.
7. Close the petcock and fill the radiator with coolant and the hydraulic reservoir with oil.

8. Hydraulic Reservoir Disassembly and Assembly

Chapter Overview

This chapter provides disassembly and assembly procedures for the hydraulic reservoir assembly. Cleaning procedures are also included for the hydraulic reservoir.

Personal Safety

! WARNING !

Improper operation, lubrication, maintenance or repair of this product can be dangerous and could result in injury or death.

Do not operate or perform any lubrication, maintenance or repair on this product until you have read and understood the operation, lubrication, maintenance, and repair information.

Before starting any disassembly or assembly procedures, refer to *Chapter 1. Product Safety – Basic Precautions* for personal safety information.

Machine Preparation

! WARNING !

Accidental machine starting can cause injury or death to personnel working on the machine.

To avoid accidental machine starting, disconnect the battery cables from the battery and tape the battery clamps and remove the key.

Place a “Do Not Operate” tag prominently on the machine to inform personnel that the machine is being worked on.

Before starting any disassembly or assembly procedures, refer to *Chapter 1. Product Safety – Repair* for machine preparation information.

Preliminary Checkout

If troubleshooting is required prior to disassembly or assembly, refer to *Chapter 15. Troubleshooting*.

Hydraulic Reservoir Disassembly and Assembly Procedures

Disassembly and assembly procedures are provided for the following hydraulic reservoir components.

- Filter Assembly
- Access Cover Assembly
- Reservoir Gauge
- Suction Screen

Note: Procedures are provided for only those hydraulic reservoir components listed above. However, information for removal and installation of other hydraulic reservoir components can be obtained from the Rubber Track Loader Parts manual.

Note: Refer to Figure 3-1 for an overview of the filtering and cooling system.

Filter Manifold Assembly Removal and Installation

The tools required for filter assembly removal and installation are listed in Table 8-1. Use manufacturer-recommended tools whenever possible.

Table 8-1

Required Tools
Combination Wrench

Note: Refer to Chapter 13, Maintenance, for procedures on changing the hydraulic filter element.

Filter Manifold Assembly Removal

! WARNING !

Hot oil can cause personal injury. Make sure the oil is cool before removing any components or lines.

Remove the oil filler cap only when the engine is stopped and the machine has been allowed to cool thoroughly.

Note: During disassembly, cap all hoses and fittings to prevent fluid loss and contamination of the system fluids.



Figure 8-1

8-001

1. Remove the hose from the filter manifold assembly. Cap hose and fitting.

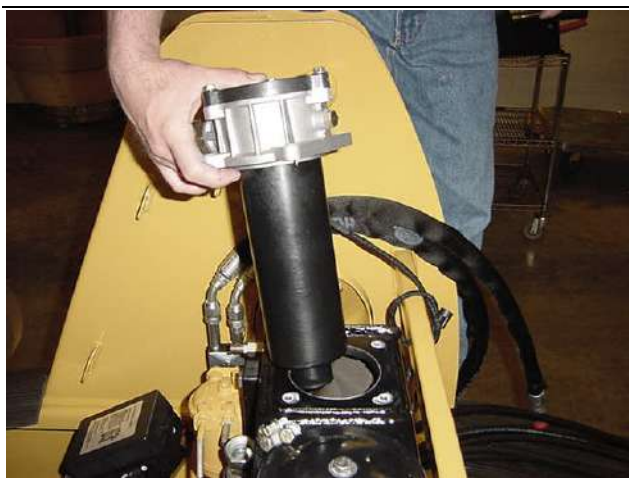

Figure 8-2

8-002

2. Remove the four bolts which fasten the filter manifold to the hydraulic reservoir.

3. Remove the filter manifold assembly. Reverse steps for installation.

Access Cover Removal and Installation

The tools required for access cover removal and installation are listed in Table 8-2. Use manufacturer-recommended tools whenever possible.

Table 8-2

Required Tools
Combination Wrench

Access Cover Assembly Removal

! WARNING !

Hot oil can cause personal injury. Make sure the oil is cool before removing any components or lines.

Remove the oil filler cap only when the engine is stopped and the machine has been allowed to cool thoroughly.



Figure 8-3

8-012

1. Slightly loosen the access cover bolt to separate the upper cap from the oval-shaped clamping disk on the underside of the assembly. This will allow the assembly to be removed. Do not remove the bolt entirely or the oval-shaped clamp will fall into the reservoir.



Figure 8-4

8-013

2. Remove the access cover assembly from the reservoir.

Access Cover Assembly Installation



Figure 8-5

8-013

1. Insert the access cover assembly with the clamping disk extending completely through the opening in the top of the reservoir and into the tank.



Figure 8-6

8-012

2. Tighten the access cover bolt.

Reservoir Gauge Removal and Installation

The tools required for reservoir gauge removal and installation are listed in Table 8-3. Use manufacturer-recommended tools whenever possible.

Table 8-3

Required Tools
Combination Wrench

Reservoir Gauge Removal

! WARNING !

Hot oil can cause personal injury. Make sure the oil is cool before removing any components or lines.

Remove the oil filler cap only when the engine is stopped and the machine has been allowed to cool thoroughly.

NOTICE

Collect and contain liquids in a suitable container. Dispose of all liquids according to local regulations and mandates.

Note: During disassembly, cap all hoses and fittings to prevent fluid loss and contamination of the system fluids.

1. Drain the hydraulic fluid. Refer to *Chapter 13. Maintenance.*
2. Remove the filter manifold. Refer to *Chapter 8. Filter Assembly Removal.*

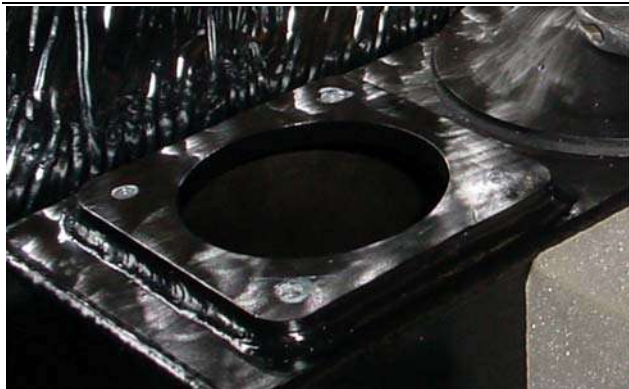

Figure 8-7 8-016

3. View of hydraulic reservoir with filter assembly removed.



Figure 8-8 8-017

4. Reach inside the reservoir and remove the two nuts that fasten the reservoir gauge to the reservoir.



Figure 8-9 8-018

5. Pull the reservoir gauge and the two mounting bolts/washers off the reservoir. **DO NOT misplace the rubber washers or the reservoir will leak.**

Reservoir Gauge Installation

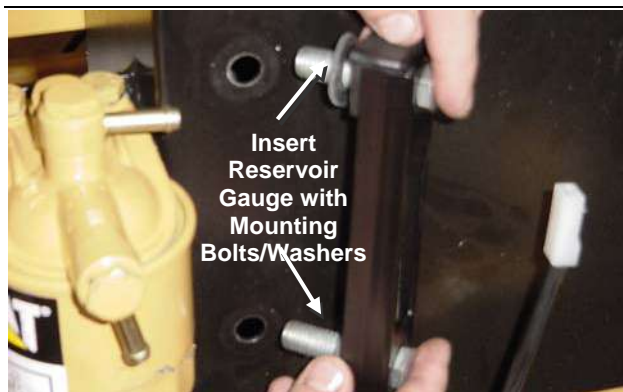

Figure 8-10 8-018

1. Install the reservoir gauge in the reservoir using the two mounting bolts/washers.



Figure 8-11 8-017

2. Reach inside the reservoir and install the two nuts that secure the reservoir gauge to the reservoir.
3. Install the filter assembly. Refer to *Chapter 8. Filter Assembly Installation*.
4. Add manufacturer-approved hydraulic fluid.

Suction Screen Removal and Installation

The tools required for suction screen removal and installation are listed in Table 8-4. Use manufacturer-recommended tools whenever possible.

Table 8-4

Required Tools
Combination Wrench

8. Hydraulic Reservoir Disassembly and Assembly

Suction Screen Removal

! WARNING !

Hot oil can cause personal injury. Make sure the oil is cool before removing any components or lines.

Remove the oil filler cap only when the engine is stopped and the machine has been allowed to cool thoroughly.

NOTICE

Collect and contain liquids in a suitable container. Dispose of all liquids according to local regulations and mandates.

Note: It is normally not necessary to replace the suction screen unless there has been a catastrophic failure and there is debris in the reservoir.

1. Drain the hydraulic fluid. Refer to *Chapter 13. Hydraulic Fluid and Filter Change.*
2. Remove the access cover assembly. Refer to *Chapter 8. Access Cover Assembly Removal.*



Figure 8-12

8-014

3. With a magnet centered in an absorbent rag, thoroughly clean the interior of the reservoir to prevent any debris from entering the system when you remove the suction filter.

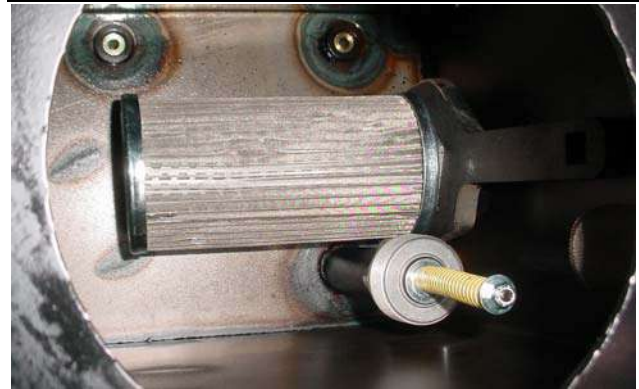

Figure 8-13

8-015

4. Reach inside the reservoir and unscrew the suction screen. Remove the suction screen from the reservoir.

Suction Screen Installation



Figure 8-14

8-015

1. Insert the suction screen in the reservoir through the access cover opening.
2. Reach inside the reservoir and screw the suction screen into the bottom of the reservoir.
3. Install the access cover assembly. Refer to *Chapter 8. Access Cover Assembly Installation.*
4. Add manufacturer-approved hydraulic fluid.

Hydraulic Reservoir Cleaning Procedures

Cleaning procedures are provided for the following hydraulic reservoir components.

- Hydraulic Reservoir

Hydraulic Reservoir Cleaning

The tools required for hydraulic reservoir cleaning are listed in Table 8-5. Use manufacturer-recommended tools whenever possible.

Table 8-5

Tool Name
Combination Wrench

! WARNING !

Hot oil can cause personal injury. Make sure the oil is cool before removing any components or lines.

Remove the oil filler cap only when the engine is stopped and the machine has been allowed to cool thoroughly.

NOTICE

Collect and contain liquids in a suitable container. Dispose of all liquids according to local regulations and mandates.

1. Drain the hydraulic fluid. Refer to *Chapter 13. Hydraulic Fluid and Filter Change*.
2. Remove the access cover assembly. Refer to *Chapter 8. Access Cover Assembly Removal*.
3. Thoroughly wipe out the interior of the hydraulic reservoir with a magnet and a clean rag.
4. Install the access cover assembly. Refer to *Chapter 8. Access Cover Assembly Installation*.
5. Add manufacturer-approved hydraulic fluid.

9. Loader/Transmission Controls Disassembly and Assembly

Chapter Overview

This chapter provides disassembly and assembly procedures for the loader and transmission controls.

Personal Safety

!WARNING!

Improper operation, lubrication, maintenance or repair of this product can be dangerous and could result in injury or death.

Do not operate or perform any lubrication, maintenance or repair on this product until you have read and understood the operation, lubrication, maintenance and repair information.

Before starting any disassembly or assembly procedures, refer to Chapter 1. Product Safety – Basic Precautions for personal safety information.

Machine Preparation

!WARNING!

Accidental machine starting can cause injury or death to personnel working on the machine.

To avoid accidental machine starting, disconnect the battery cables from the battery, tape the clamps and remove the key.

Place a “Do Not Operate” tag prominently on the machine to inform personnel that the machine is being worked on.

Before starting any disassembly or assembly procedures, refer to Chapter 1. Product Safety – Repair for machine preparation information.

Preliminary Checkout

If troubleshooting is required prior to disassembly or assembly, refer to Chapter 15. Troubleshooting.

Loader/Transmission Controls Disassembly and Assembly Procedures

Disassembly and assembly procedures are provided for the following loader/transmission control components.

- Drive Control Joystick
- Loader Control Joystick
- Loader Float Magnet
- Loader Valve
- Self Level Valve

Note: Procedures are provided for only those loader/transmission control components listed above. However, information for removal and installation of other loader/transmission control components can be obtained from the Rubber Track Loader Parts manual.

Note: Refer to Figure 3-2 for an overview of the auxiliary circuit system and Figure 3-3 for an overview of the drive loop system.

Loader Control Joystick/Drive Control Joystick Removal and Installation

There are two joysticks that control the operation of the machine: a drive control joystick and a loader control joystick.

Drive Control Joystick Operation – The left-hand joystick controls the speed and direction of the machine. The further the joystick is pushed, the faster the machine travels. The joystick operates on hydraulic charge pressure. When the joystick is moved, oil is sent to the hydrostatic transmission. The transmission then delivers oil, in the correct amount, to the drive motors.

9. Loader/Transmission Controls

Loader Control Joystick Operation – The right-hand joystick controls the loader arm and the at-tachment tilt cylinder. It allows the operator to raise, lower and pivot the attachment. The joystick operates on hydraulic charge pressure.

The loader control also has a float position, which is activated by moving the joystick completely forward until it is held in detent. The joystick is held in the forward float position by an electromagnet.

The tools required for loader/drive control joystick removal and installation are listed in Table 9 1. Use manufacturer recommended tools whenever possible.

Table 9-1

Required Tools
Combination/Socket Wrenches
Screwdriver (phillips)

Loader Control Joystick/Drive Control Joystick Removal

Note: The procedures for removing both joystick controls are nearly identical, as a result, only the right control joystick procedure is described below.

Note: During disassembly, cap and plug all hoses and fittings to prevent fluid loss and contamination of the system fluids.

!WARNING!

Relax all hydraulic circuits/controls and make sure the oil is cool before disconnecting any component or line from the system. Pressurized and or hot hydraulic fluid can cause personal injury.

1. Remove the seat from the machine according to the procedure in chapter 6, seat removal.
2. Lower the lift arms to the ground.
3. Turn the ignition switch to the OFF position.
4. Relax all hydraulic circuits.



Figure 9-1

9-001

5. Remove the various screws holding the plastic side consoles to the cab enclosure as shown.



Figure 9-2

9-002

6. Pivot the panel away from the joystick, then lift and remove it from the machine.



Figure 9-3

9-003

7. Remove the three nuts securing the joystick mount to the cab enclosure from the outside of the machine.



Figure 9-4 9-004

8. Pull the joystick away from the cab wall as shown.



Figure 9-5 9-005

9. The hydraulic hoses are now accessible. Label them and the ports they connect to to aid during reassembly, then disconnect them and cap and plug the openings to prevent spills.



Figure 9-6 9-006

10. Disconnect the electrical connections shown to free the joystick from the machine, then remove.

11. Reverse the removal procedure to reinstall the joystick. Take care to ensure all connections are to the appropriate ports on the joystick and that they are tight and leak free.

Note: If it is necessary to remove the left joystick on a machine equipped with a heater, you must disconnect the (cool) heater lines at the heater unit in order to remove the side panel. Cap and plug hoses and ports to minimize coolant loss.

Loader Float Magnet Removal and Installation

The tools required for loader float magnet removal and installation are listed in Table 9-2. Use manufacturer recommended tools whenever possible.

Table 9-2

Required Tools
Allen (hex) Wrenches
Combination Wrenches
Screwdriver

Loader Float Magnet Removal



Figure 9-7 9-007

1. Remove the zip tie securing the lower portion of the joystick boot to the joystick as shown.

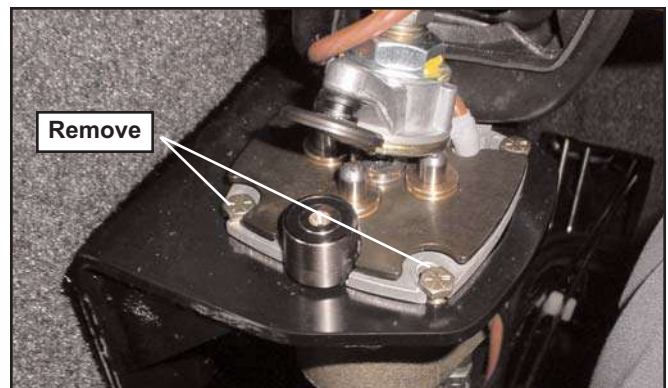

Figure 9-8 9-008

2. Lift the boot to expose the magnet and joystick mounting bolts. Remove the joystick mounting bolts to allow the joystick to be moved upward within the bracket.



Figure 9-9 9-009

3. Use an allen (hex) wrench to remove the bolt securing the magnet to the joystick.

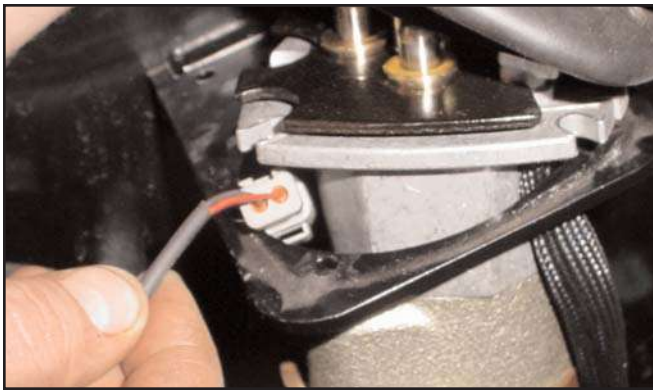

Figure 9-10 9-010

4. Lift the joystick out of the mounting bracket slightly to allow the magnet connector to pass between them, then remove the magnet.
5. To install the float magnet, reverse the removal procedure.

Loader Valve Removal and Installation

The tools required for loader valve removal and installation are listed in Table 9-3. Use manufacturer-recommended tools whenever possible.

Table 9-3

Required Tools
Combination Wrenches

Loader Valve Removal

!WARNING!

Hot oil can cause personal injury. Lower all attachments and make sure the oil is cool before removing any components or lines.

Remove the oil filler cap only when the engine is stopped and the machine has been allowed to cool thoroughly.

NOTICE

Collect and contain liquids in a suitable container. Dispose of all liquids according to local regulations and mandates.

Note: During disassembly, cap all hoses and fittings to prevent fluid loss and contamination of the system fluids.

1. Lower the lift arms to the ground.
2. Turn the engine start switch to the OFF position.
3. Relieve hydraulic pressure from the auxiliary circuit.
4. Drain the hydraulic fluid. Refer to Chapter 13. Hydraulic Fluid and Filter Change.



Figure 9-11 9-011

5. Disconnect the gas springs, then remove the bolts securing the hood as shown to allow for removal.



Figure 9-14 9-014

8. Carefully remove the rear valance from the machine to allow access to the loader valve.



Figure 9-12 9-012

6. Carefully remove the hood from the machine and set it aside.

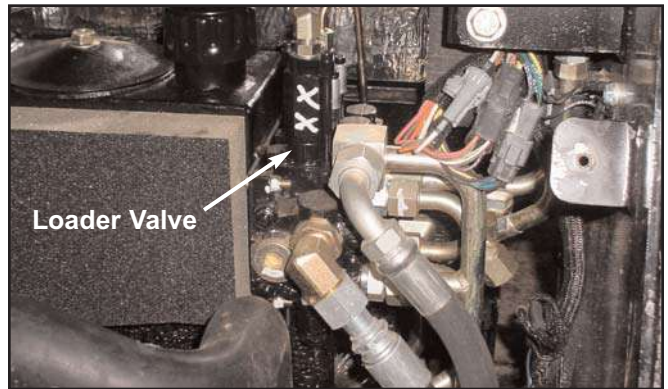

Figure 9-15 9-015

9. Locate the loader valve on the side of the hydraulic reservoir.

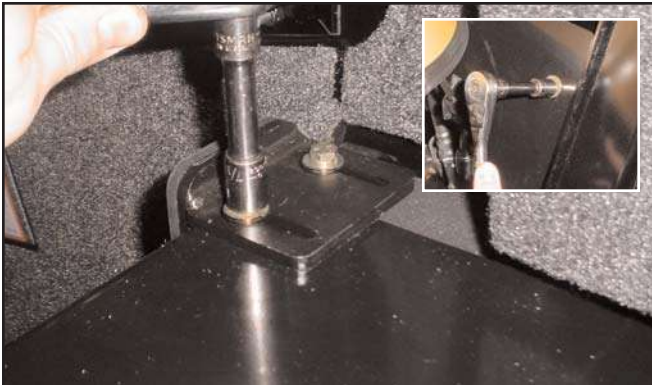

Figure 9-13 9-013

7. Remove the bolts securing the rear valance panel to the chassis to allow for removal.

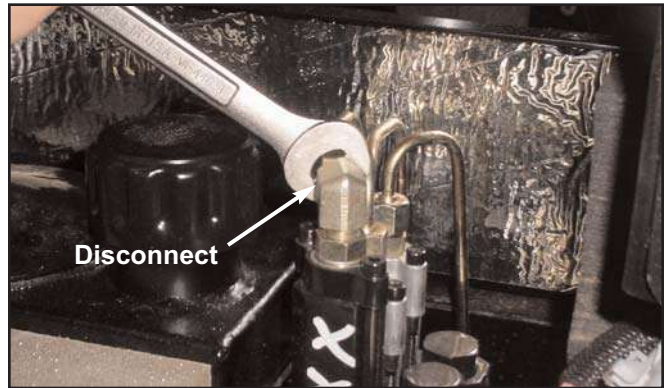

Figure 9-16 9-016

10. Disconnect all of the tubes from the loader valve. Cap and plug all openings to prevent fluid loss.

9. Loader/Transmission Controls

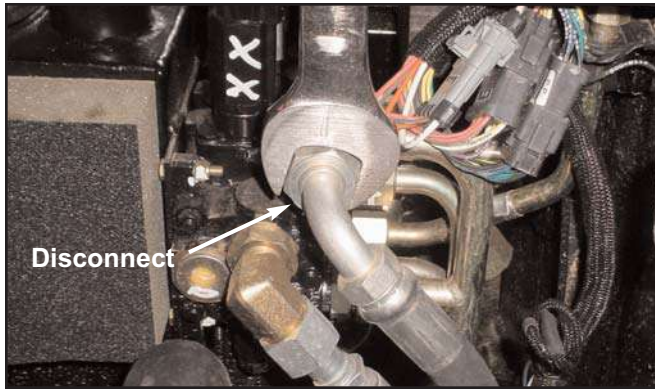

Figure 9-18

9-018

11. Disconnect the hoses from the rear and side of the loader valve. Cap and plug all openings to prevent fluid loss.

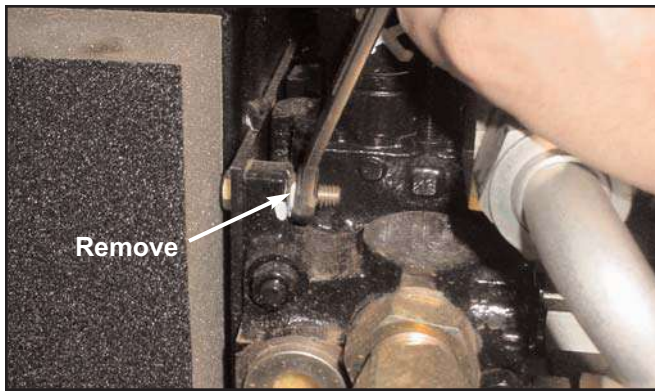

Figure 9-19

9-019

12. Remove the nuts securing the valve to the reservoir as shown, then remove the valve from the machine.

13. To reinstall, reverse the removal procedure.

14. Once all components have been reinstalled and are secure, add manufacturer approved hydraulic fluid until full mark is reached on the level gauge.

Note: To eliminate trapped air from the system, activate all hydraulic circuits and run machine through its paces including moving the lift arms up and down, curling and tilting the Q/A, driving forward and in reverse, and activating the auxiliary circuit. Then, check hydraulic fluid level and add as required to reach full mark.

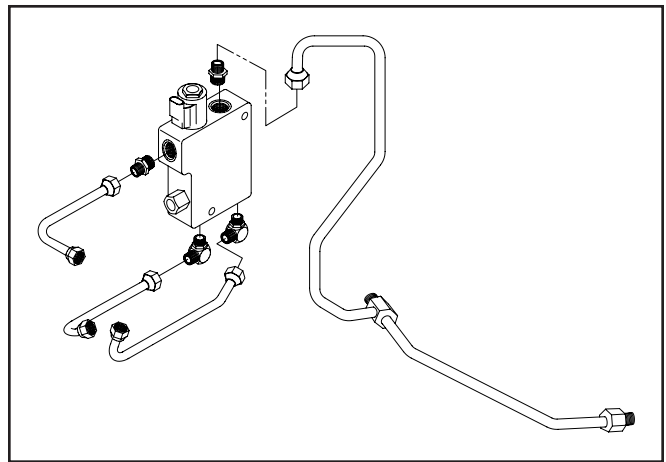

Figure 9-19

9-019

Self Level Valve Removal and Installation

The tools required for loader valve removal and installation are listed in Table 9-4. Use manufacturer recommended tools whenever possible.

Table 9-4

Required Tools
Combination Wrenches

Loader Valve Removal

!WARNING!

Hot oil can cause personal injury. Lower all attachments and make sure the oil is cool before removing any components or lines.

NOTICE

Collect and contain liquids in a suitable container. Dispose of all liquids according to local regulations and mandates.

Note: During disassembly, cap all hoses and fittings to prevent fluid loss and contamination of the system fluids.

1. Lower the lift arms to the ground.
2. Disconnect all tubes and wire harness from the self level valve.
3. Remove the bolts securing the valve to the chassis, then remove from the machine.
4. To reinstall, reverse the removal procedure.

10. Hydrostatic and Aux. Pump Disassembly and Assembly

Chapter Overview

This chapter provides disassembly and assembly procedures for the hydrostatic and auxiliary pump.

Personal Safety

! WARNING !

Improper operation, lubrication, maintenance or repair of this product can be dangerous and could result in injury or death.

Do not operate or perform any lubrication, maintenance or repair on this product until you have read and understood the operation, lubrication, maintenance and repair information.

Before starting any disassembly or assembly procedures, refer to *Chapter 1. Product Safety – Basic Precautions* for personal safety information.

Machine Preparation

! WARNING !

Accidental machine starting can cause injury or death to personnel working on the machine.

To avoid accidental machine starting, disconnect the battery cables from the battery, tape the clamps and remove the key.

Place a “Do Not Operate” tag prominently on the machine to inform personnel that the machine is being serviced.

Before starting any disassembly or assembly procedures, refer to *Chapter 1. Product Safety – Repair* for machine preparation information.

Preliminary Checkout

If troubleshooting is required prior to disassembly or assembly, refer to *Chapter 15. Troubleshooting*.

Hydrostatic and Hydraulic Pump Disassembly and Assembly Procedures

Disassembly and assembly procedures are provided for the following transmission and drive components.

- Auxiliary Gear Pump
- Tandem Pump
- Pump Drive Coupler

Note: Procedures are provided for only those transmission and drive components listed above. However, information for removal and installation of other transmission and drive components can be obtained from the Rubber Track Loader Parts Manual.

Note: Refer to Figure 3-2 for an overview of the auxiliary circuit system and Figure 3-3 for an overview of the drive loop system.

Auxiliary Gear Pump Removal and Installation

The tools required for auxiliary gear pump removal and installation are listed in Table 10-1. Use manufacturer recommended tools whenever possible.

Table 10-1

Required Tools
Screwdriver
Combination Wrench
Socket Wrench

Auxiliary Gear Pump Removal

! WARNING !

Hot oil can cause personal injury. Lower all attachments and make sure the oil is cool before removing any components or lines.

10. Transmission and Drive Disassembly and Assembly

Remove the oil filler cap only when the engine is stopped and the machine has been allowed to cool thoroughly.

NOTICE

Collect and contain liquids in a suitable container. Dispose of all liquids according to local regulations and mandates.

Note: During disassembly, cap all hoses and fittings to prevent fluid loss and contamination of the system fluids.

1. Lower the lift arms to the ground.
2. Turn the ignition switch to the OFF position.
3. Relieve any pressure from the auxiliary hydraulic circuit.
4. Drain the hydraulic fluid. Refer to *Chapter 13. Hydraulic Fluid and Filter Change.*
5. Remove the seat. Refer to *Chapter 6. Seat Removal.*

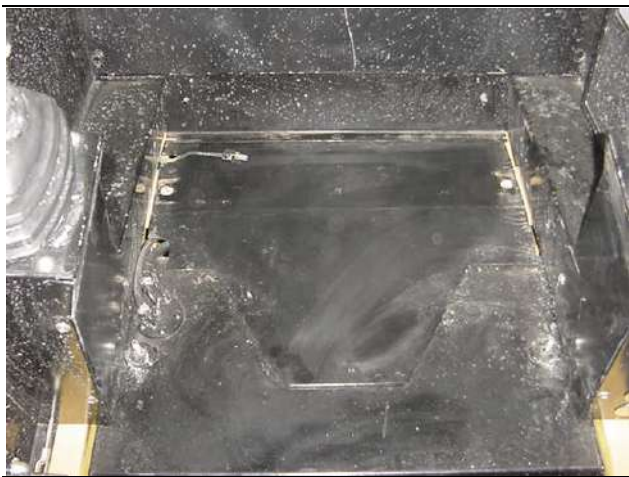

Figure 10-1

10-001

6. View with seat removed.



Figure 10-2

10-002

7. Remove the access cover beneath the seat.

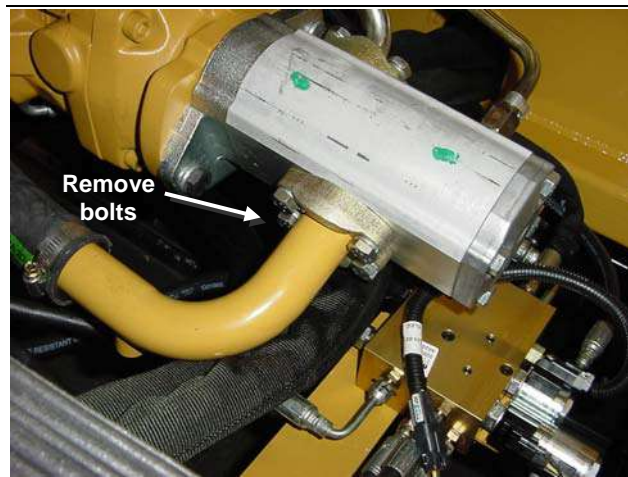

Figure 10-3

10-003

8. Remove the bolts securing the flange fitting.



Figure 10-4

10-004

9. Disconnect the fitting and tube from the pump.

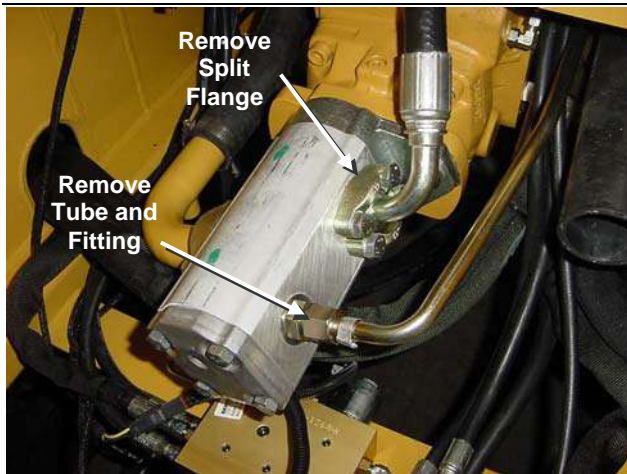

Figure 10-5

10-005

10. Remove the other split flange fitting and the remaining tube and fitting.

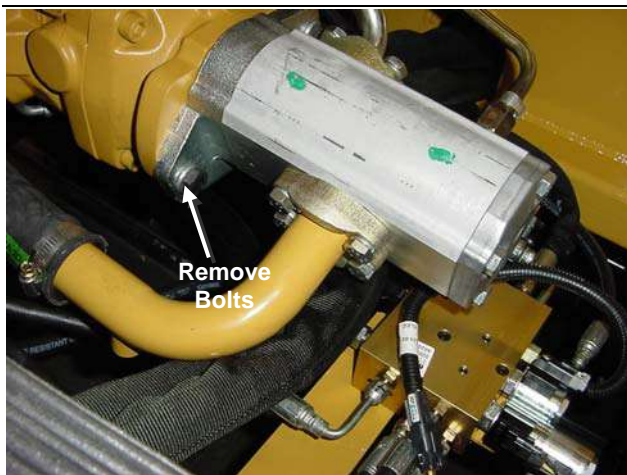

Figure 10-6

10-006

11. Remove the 2 bolts that mount the auxiliary gear pump to the tandem pump, then remove it.

Tandem Pump Removal and Installation

The tools required for tandem pump removal and installation are listed in Table 10-2. Use manufacturer-recommended tools whenever possible.

Table 10-2

Required Tools
Screwdriver
Combination Wrench
Socket Wrench

Tandem Pump Removal

! WARNING !

Hot oil can cause personal injury. Lower all attachments and make sure the oil is cool before removing any components or lines.

Remove the oil filler cap only when the engine is stopped and the machine has been allowed to cool thoroughly.

NOTICE

Collect and contain liquids in a suitable container. Dispose of all liquids according to local regulations and mandates.

Note: During disassembly, cap all hoses and fittings to prevent fluid loss and contamination of the system fluids.

1. Lower the lift arms to the ground.
2. Turn the ignition switch to the OFF position.
3. Relieve hydraulic pressure from the auxiliary circuit.
4. Drain the hydraulic fluid. Refer to *Chapter 13. Hydraulic Fluid and Filter Change*.
5. Remove the seat. Refer to *Chapter 6. Seat Removal*.
6. Remove the auxiliary gear pump. Refer to *Chapter 10. Auxiliary Gear Pump Removal*.
7. Remove the belly pan.

10. Transmission and Drive Disassembly and Assembly

8. Disconnect all hoses and tubes from the tandem pump. Cap/plug the hoses and tubes.

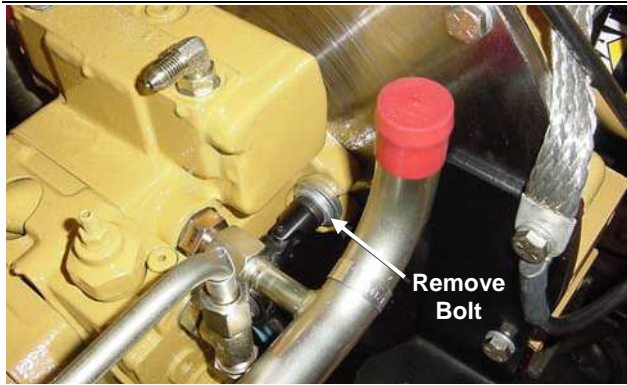

Figure 10-7

10-008

9. Remove the mounting bolt (with spring lock washer and flat washer) from the right-hand side of the tandem pump.



Figure 10-8

10-009

10. Remove the mounting bolt (with spring lock washer and flat washer) from the left-hand side of the tandem pump, then remove as shown.

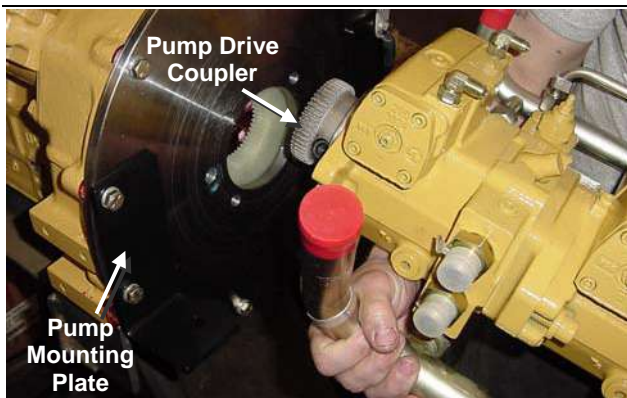

Figure 10-9

10-010

Tandem Pump Installation

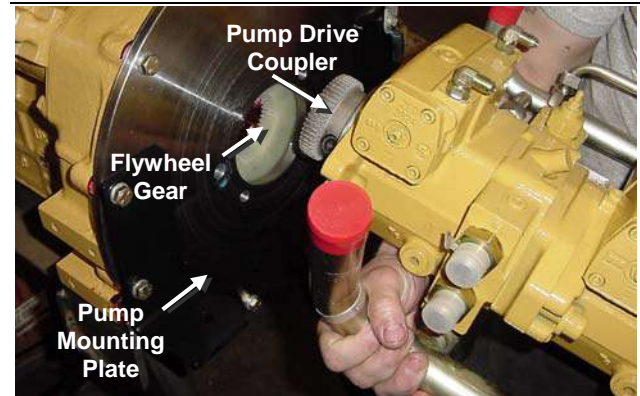

Figure 10-10

10-010

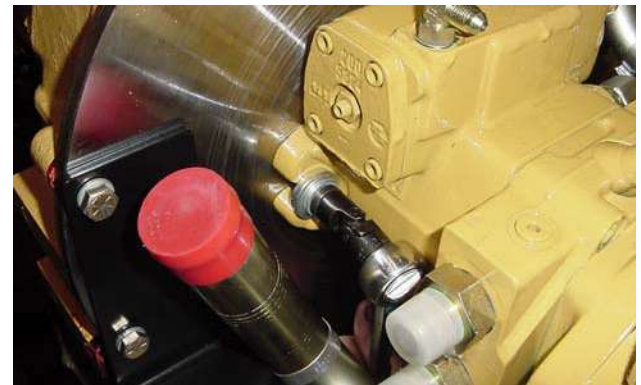

Figure 10-11

1. Install the pump and mounting bolts/washers as found upon removal. Apply blue loctite to the threads of each bolt, then tighten to 85 ft.-lb.



Figure 10-12

10-008

2. Reconnect the hoses and tubes to the tandem pump as found upon removal.
3. Install the auxiliary gear pump. Refer to *Chapter 10. Auxiliary Gear Pump Installation*.

4. Install the access cover and seat. Refer to *Chapter 6. Seat Installation*.
5. Add fuel and manufacturer-approved hydraulic fluid.

Pump Drive Coupler Removal and Installation

The tools required for pump drive coupler removal and installation are listed in Table 10-3. Use manufacturer-recommended tools whenever possible.

Table 10-3

Required Tools
Screwdriver
Combination Wrench
Socket Wrench

Pump Drive Coupler Removal

! WARNING !

Hot oil can cause personal injury. Lower all attachments and make sure the oil is cool before removing any components or lines.

Remove the oil filler cap only when the engine is stopped and the machine has been allowed to cool thoroughly.

NOTICE

Collect and contain liquids in a suitable container. Dispose of all liquids according to local regulations and mandates.

Note: During disassembly, cap all hoses and fittings to prevent fluid loss and contamination of the system fluids.

1. Lower the lift arms to the ground.
2. Turn the ignition switch to the OFF position.
3. Relieve hydraulic pressure from the auxiliary circuit.
4. Drain the hydraulic fluid. Refer to *Chapter 13. Hydraulic Fluid and Filter Change*.

5. Remove the seat. Refer to *Chapter 6. Seat Removal*.
6. Remove the auxiliary gear pump. Refer to *Chapter 10. Auxiliary Gear Pump Removal*.
7. Remove the tandem pump. Refer to *Chapter 10. Tandem Pump Removal*.

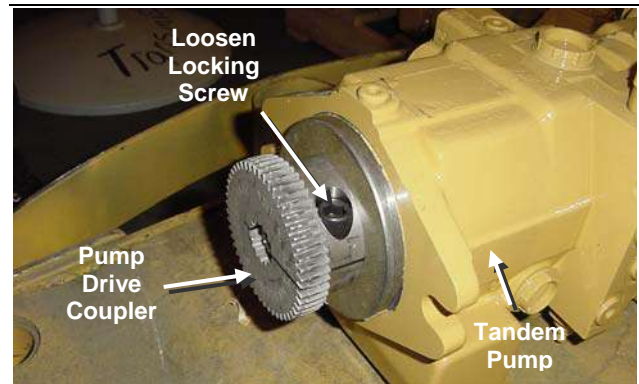

Figure 10-13

10-011

8. Loosen the locking screw that secures the pump drive coupler to the drive shaft extending from the end of the tandem pump.

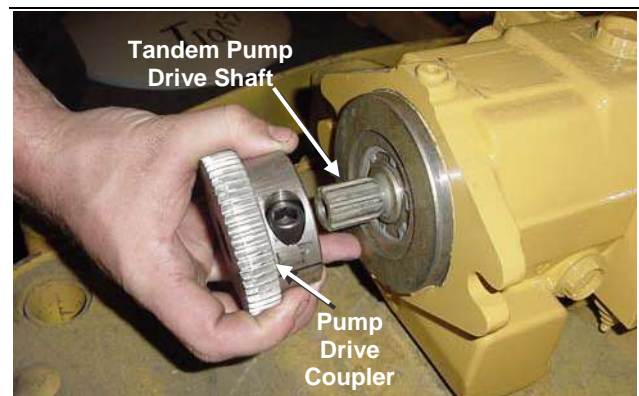

Figure 10-14

10-012

9. Slide the pump drive coupler off the tandem pump drive shaft.

Pump Drive Coupler Installation

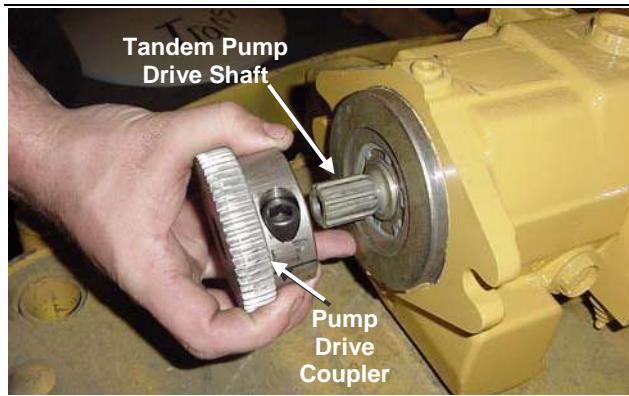

Figure 10-15

10-012

1. Slide the pump drive coupler all the way onto the tandem pump drive shaft.

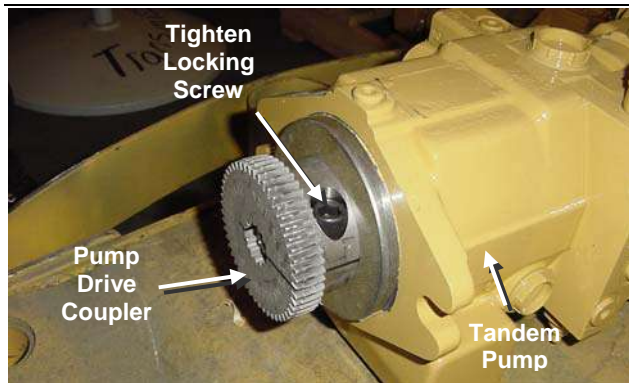

Figure 10-16

10-011

2. Tighten the locking screw that secures the pump drive coupler to the tandem pump drive shaft.
3. Install the tandem pump. Refer to *Chapter 10. Tandem Pump Installation*.
4. Install the auxiliary gear pump. Refer to *Chapter 10. Auxiliary Gear Pump Installation*.
5. Install the seat. Refer to *Chapter 6. Seat Installation*.
6. Add fuel and manufacturer-approved hydraulic fluid.

11. Undercarriage Disassembly and Assembly

Chapter Overview

This chapter provides disassembly and assembly procedures for the undercarriage assemblies.

Personal Safety

! WARNING !

Improper operation, lubrication, maintenance or repair of this product can be dangerous and could result in injury or death.

Do not operate or perform any lubrication, maintenance or repair on this product until you have read and understood the operation, lubrication, maintenance and repair information.

Before starting any disassembly or assembly procedures, refer to *Chapter 1. Product Safety – Basic Precautions* for personal safety information.

Machine Preparation

! WARNING !

Accidental machine starting can cause injury or death to personnel working on the machine.

To avoid accidental machine starting, disconnect the battery cables from the battery and tape the battery clamps and remove the key.

Place a “Do Not Operate” tag prominently on the machine to inform personnel that the machine is being worked on.

Before starting any disassembly or assembly procedures, refer to *Chapter 1. Product Safety – Repair* for machine preparation information.

Preliminary Checkout

If troubleshooting is required prior to disassembly or assembly, refer to *Chapter 15. Troubleshooting*.

Undercarriage Disassembly and Assembly Procedures

Disassembly and assembly procedures are provided for the following undercarriage components.

- Center wheels
- End wheels
- Sprocket rollers
- Tracks
- Outboard bearings
- Drive sprockets
- Drive motors
- Idler (end wheel) hub assemblies

Note: Procedures are provided for only those undercarriage components listed above. However, other helpful information can be obtained from the Rubber Track Loader Parts Manual.

Center Wheel Removal and Installation

The tools required for wheel removal and installation are listed in Table 11-1. Use manufacturer-recommended tools whenever possible.

Table 11-1

Required Tools
Wheel Extractor
Channel Lock Pliers
Socket Wrench
Screw Driver

Wheel Removal

1. Locate the wheel cap snap ring.



Figure 11-1 11-005

2. Use a screw driver to remove the snap ring that secures the wheel cap.



Figure 11-2 11-006

3. Using a large channel lock pliers, remove the wheel cap.



Figure 11-3 11-007



Figure 11-4 11-008

4. Using a socket, remove the nut that fastens the wheel to the shaft. Remove the wheel with the wheel extractor.



Figure 11-5 11-009

5. To remove an inside wheel, slide under the machine and repeat the wheel removal procedure.



Figure 11-6 11-010

6. With wheels removed, inspect the bearings and axle for wear or damage.

11. Undercarriage Disassembly and Assembly

End Wheels

The tools required for wheel removal and installation are listed in table 11-2. Use manufacturer recommended tools whenever possible.

Table 11-2

Required Tools
Socket/impact wrench Heavy duty hydraulic jack Combination wrench ASV approved jack stands (2)

Removal



Figure 11-7 11-011

1. Raise and support the machine on ASV jackstands in the front and rear as shown.



Figure 11-8 11-012

2. Clean the threads with a plastic or wire bristle brush, then loosen the turnbuckle as shown to lower the drive table and create slack in the track.



Figure 11-9 11-013

3. Remove the bolts securing the wheel to the hub.



Figure 11-10 11-014

4. Slide the track outward as you pull on the wheel to remove the wheel.

Installation

1. To install the end wheels, reverse the removal procedure. **Torque the end wheel mounting bolts upon installation to 95 +/- 10 Lb. Ft.**

11. Undercarriage Disassembly and Assembly

Sprocket Rollers

The tools required for sprocket roller removal and installation are listed in table 11-3. Use manufacturer recommended tools whenever possible.

Table 11-3

Required Tools
Combination/Socket Wrench

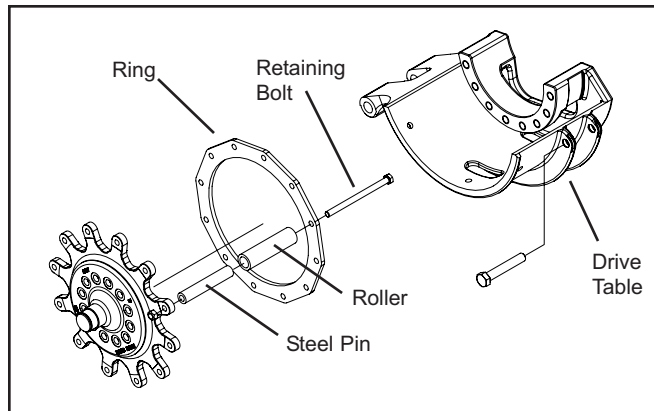

Figure 11-11

11-015



Figure 11-12

11-016

1. Position the sprocket so that you can easily access one bolt/roller/pin assembly. With the engine off and controls in neutral, remove the retaining bolt and with it the roller and steel pin.
2. Inspect the pin and roller for wear or cracking and replace as necessary. If any of the rollers show signs of wear through or cracking, replace them. If the pins are worn or cracked, replace them as well.

Note: Replace rollers and pins (if necessary) as a set. This will simplify future inspection and minimize redundant maintenance.

Track Removal and Installation

The tools required for track removal and installation are listed in table 11-4. Use manufacturer recommended tools whenever possible.

Table 11-4

Required Tools
Socket/impact wrench
Heavy duty hydraulic jack
Combination wrench
ASV approved jack stands (2)

Removal

1. Perform the end wheel removal procedure located on page 11-3 of this chapter.



Figure 11-13

11-017

2. Once the wheel has been removed, pull the track off of the front of the undercarriage, then lift over the drive sprocket and off of the rear of the undercarriage to remove.

Installation



Figure 11-14

11-018

1. To install the track, reverse the removal procedure.

Note: When installing the track it is helpful to lubricate the inner front wheel surface to help slide the track into position.

Outboard Bearing Removal and Installation

The tools required to remove and install the outboard bearing assembly are listed in table 11-5. Use manufacturer recommended tools whenever possible.

Table 11-5

Required Tools
Combination/socket wrench
Snap ring pliers
Puller
Hammer/chisel

Removal



Figure 11-15 11-019

1. Remove the four bolts securing the bearing to the mounting plate.



Figure 11-16 11-020

2. Remove the 3 bolts securing the mounting plate to the drive table, then use a chisel to **gently** separate the two components. Remove the mounting plate from the machine.

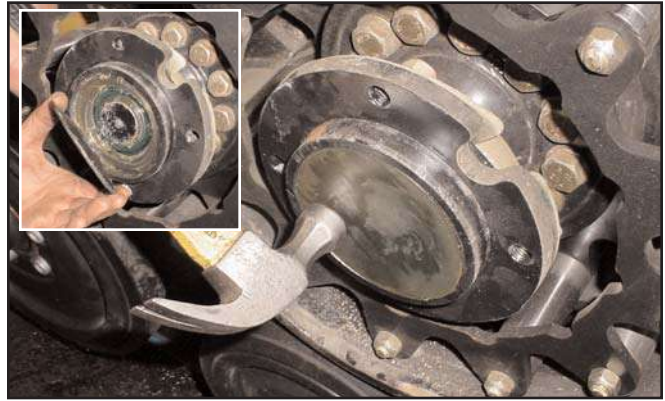

Figure 11-17 11-021

3. Use a hammer to tap around the perimeter of the bearing cap. This will relieve the outward pressure on the housing and allow the cap to be removed.



Figure 11-18 11-022

4. Use a snap ring pliers to remove the snap ring retainer from the shaft as shown.

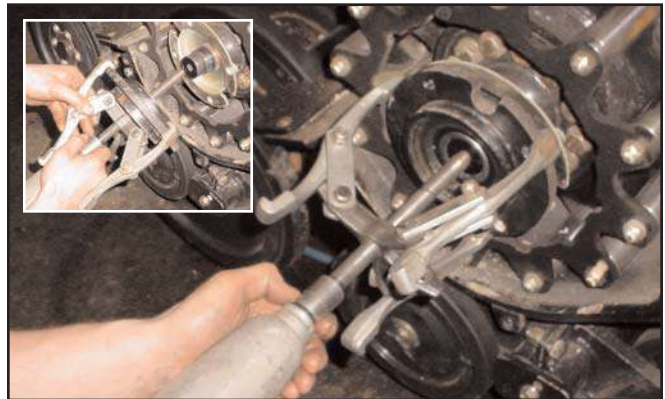

Figure 11-19 11-023

5. Use a puller to remove the bearing assembly from the machine as shown.

Installation

1. To install the outboard bearing, reverse the removal procedure.

Drive Sprocket Removal and Installation

The tools required to remove and install the drive sprocket assembly are listed in table 11-6. Use manufacturer recommended tools whenever possible.

Table 11-6

Required Tools
Combination/socket wrench
Snap ring pliers
Puller
Hammer/chisel

Removal

1. Perform the outboard bearing removal procedure as described on page 11-5 of this chapter.



Figure 11-20

11-024

2. Remove the nuts securing the sprocket to the drive motor, then carefully remove the drive sprocket.

Installation

1. To install the drive sprocket, reverse the removal procedure.

Drive Motor Removal and Installation

The tools required to remove and install the drive motor are listed in table 11-7. Use manufacturer recommended tools whenever possible.

Table 11-7

Required Tools
Combination/socket wrench
Crow's foot

Removal

1. Perform the drive sprocket removal procedure as described on page 11-6 of this chapter.



Figure 11-21

11-025

2. Remove the bolts securing the drive motor to the drive table as shown.



Figure 11-22

11-026

3. Disconnect the various hoses from the drive motor (noting their positions and orientations for reassembly), then remove the drive motor from the machine. (cap or plug all tubes/hoses/fittings)

Installation

1. To install the drive motor, reverse the removal procedure.

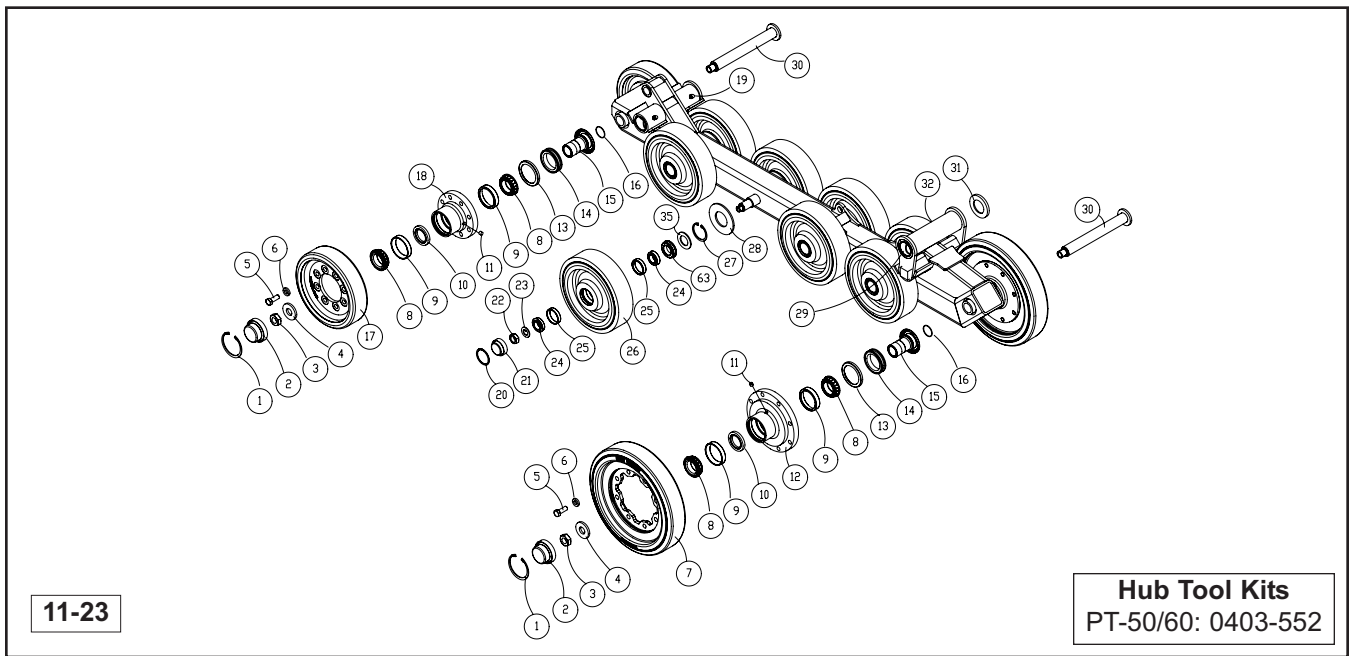

Idler Hub

Service Procedure PT-50/60

Required Tools
Socket Wrench & Sockets (including Allen)
Press & Tool Kit (0403-552)
Snap Ring Pliers

1. Remove the hub assemblies from the undercarriages as required first by performing the track removal procedure on page 11-4. Then proceed to the steps below.
2. Remove the snap ring (item 1) securing the cap (item 2) in the hub assembly. (fig. 11-23)
3. Remove the nut (item 3) and the washer (item 4), then remove the hub assembly from the axle shaft. (fig. 11-23) (see note below)

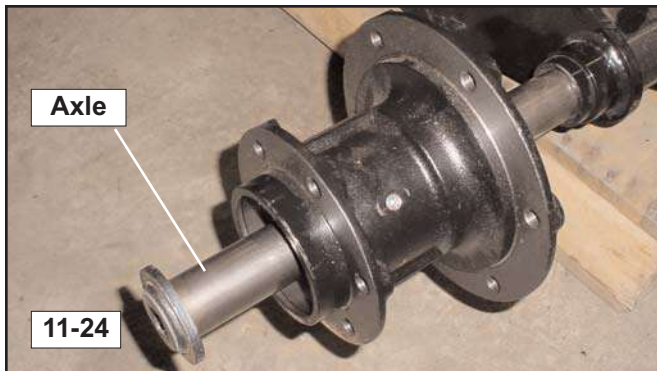

4. Using a press and tool # 0403-550, press the bearing sleeve out of the hub assembly. (fig. 11-25, 11-26)

Note: If you are removing either of the the inner hub assemblies, you must slide the axle (item 30) out of the main rail weldment to remove it. (fig. 11-24)

11. Undercarriage Disassembly and Assembly



11-27

- Remove the bearing out of the front of the hub as shown as well as the metal face seal half and rubber ring from the rear of the hub. (fig. 11-27)

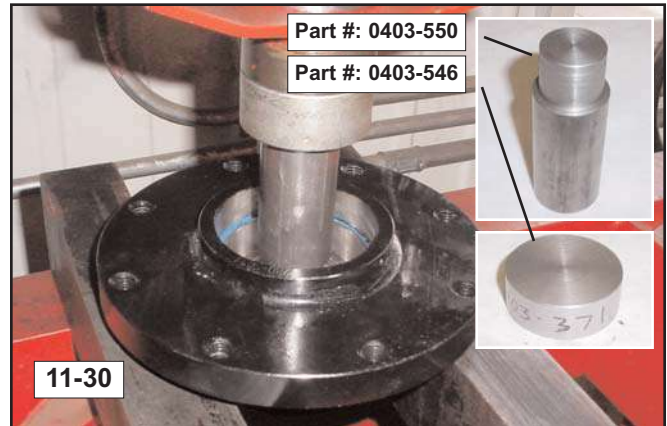

11-30



11-31

- Press the front race out of the hub from the rear using tools 0403-546 and 0403-550. (fig. 11-30, 11-31)

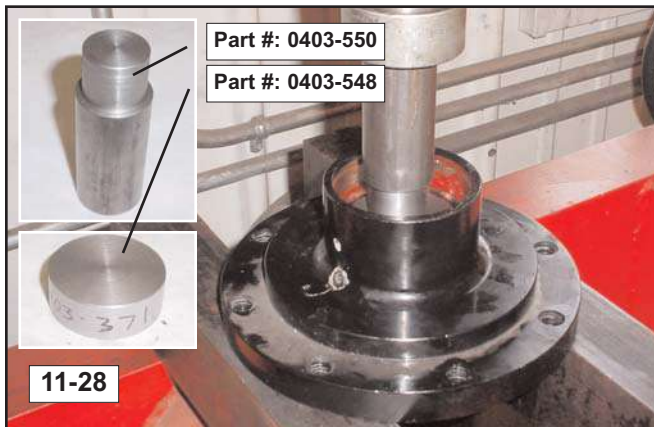

11-28

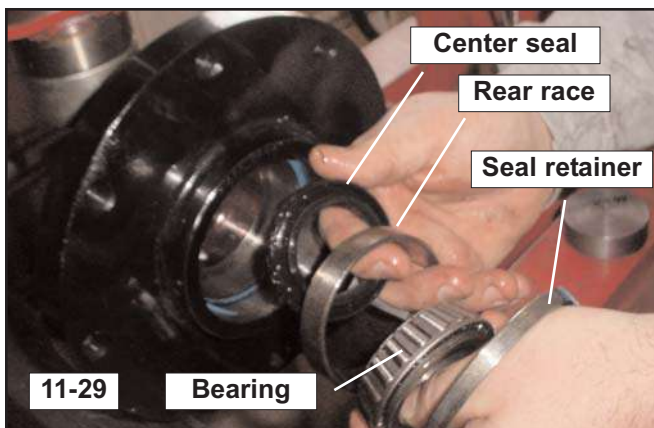

11-29

- Press the center seal, rear bearing/race, and seal retainer out of the assembly from the front of the hub using tools 0403-548 and 0403-550. (fig. 11-28, 11-29)

Note: The center seal will be destroyed during removal and must be replaced upon reassembly.

Note: Take care not to drop the metal face seal halves. The sealing surfaces are surface ground and have an extremely fine finish. If scratched or disfigured, the seal will not function as intended.

Note: Now is a good time to inspect the components for damage or wear. If the bearings do not roll smoothly when rotated, replace them. If the seals appear worn or damaged, replace them. If the wheels are worn or damaged, replace them. If the components appear to be in good working condition, you may reuse them.

11. Undercarriage Disassembly and Assembly

8. Thoroughly clean all parts with parts cleaning solution and gently blow them clean with air if necessary, then wipe dry.
9. Disassemble and clean the face seals and their rubber outer seals thoroughly, then wipe them dry to ensure a good seal when assembled.

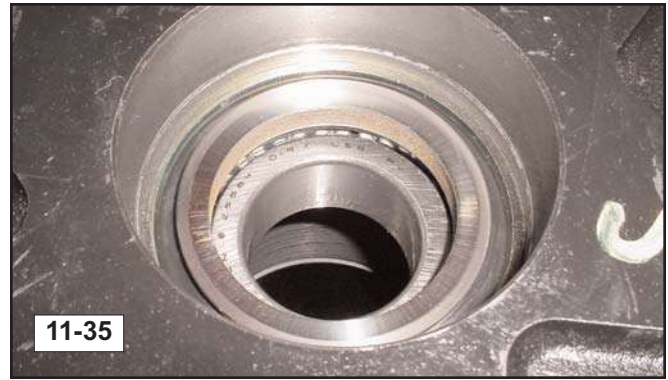
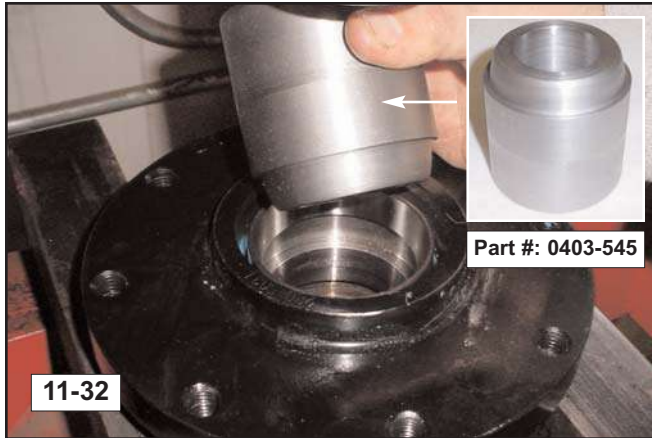

12. Install the face seal and rubber ring into the retainer as shown. Make sure the parts are clean and dry and that the rubber ring seats into the retainer. (fig. 11-35)

10. Once components are clean and dry, install the rear bearing race with tool #: 0403-545 from the rear of the hub as shown. (fig. 11-32)

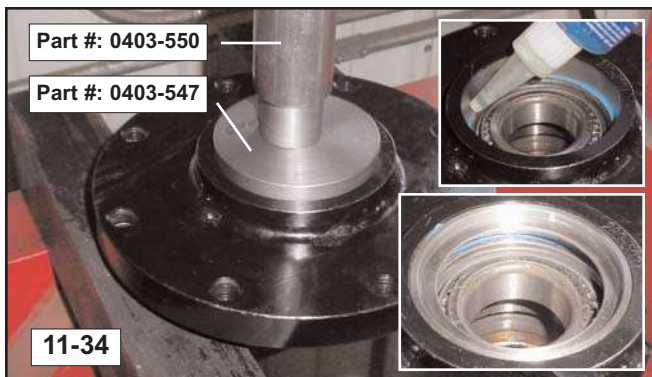

13. Once the seals are in place, wipe the mating surfaces of the face seals with a clean shop cloth and alcohol in a circular motion ending in a gentle sweep from the inside to the outside of the face until clear of the face. This will ensure a clean mating surface and a good seal. (fig. 11-36, 11-37)

11. Install the rear bearing (clean and dry) into the assembly, then press the rear seal retaining ring into the assembly with tool #: 0403-547 and extension 0403-550. (apply blue loc-tite around the ring sealing surface in the hub prior to installation) (fig. 11-33, 11-34)

11. Undercarriage Disassembly and Assembly



14. Apply a **very thin** coating of fresh 10W30 engine oil onto the now clean seal faces (faces only) in a circular motion. (fig. 11-38)

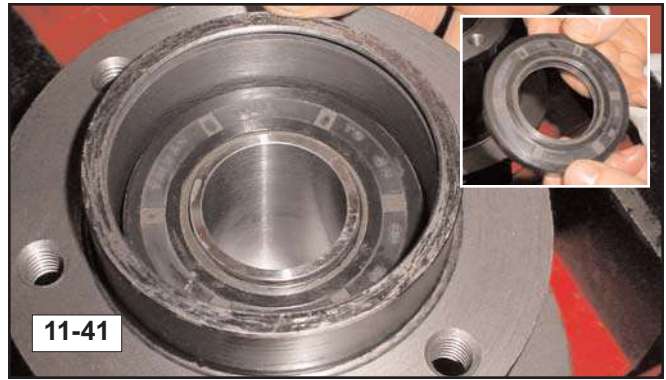

17. Install the center seal into the hub. Work the lip around the bearing sleeve with your fingers prior to pressing it into place. (fig. 11-41)

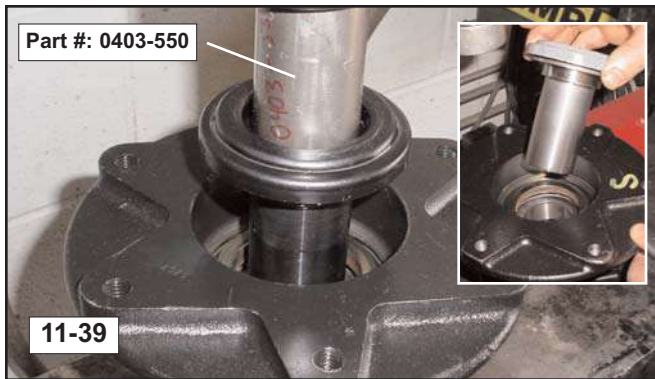

15. Press the bearing sleeve assembly (with face seal clean, installed, and oiled) into the hub with tool 0403-550 until seated. (fig. 11-39)



18. Install the front race into the hub as shown above the seal. When the race is pressed into place, it will push the seal into position. (fig. 11-42)

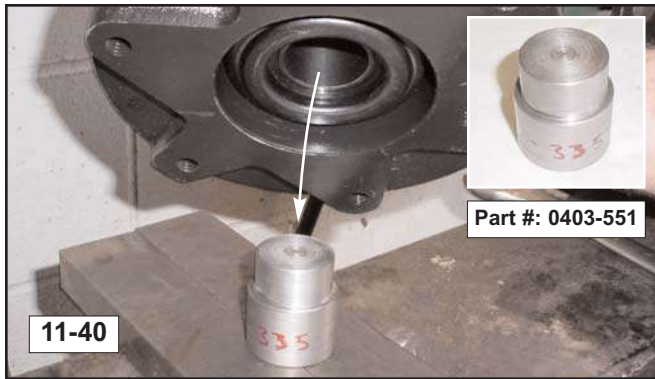

16. Flip the hub over, support the bearing sleeve from the bottom with tool #: 0403-551 and set it onto the press for center seal installation. (fig. 11-40)

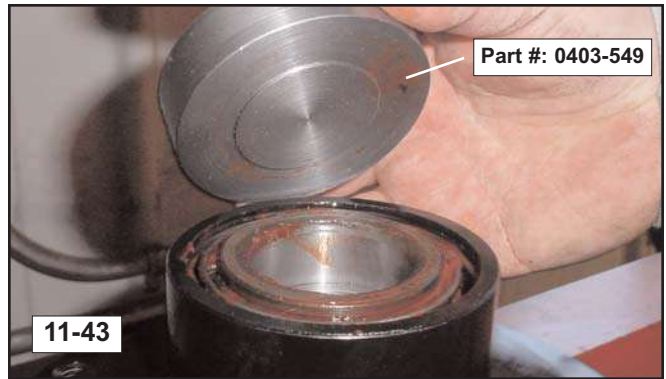

19. Install the bearing (cleaned, dried and repacked with ASV Multi-Purpose EP Lithium Grease) onto the bearing sleeve as shown. Press into the assembly until seated against the race. (fig. 11-43)



20. If necessary, use a needle dispenser to fill any places in the bearing that are not full of grease to ensure adequate lubrication. (fig. 11-44)

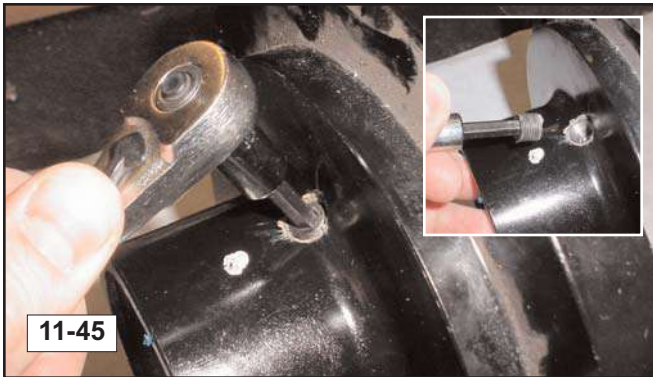

21. Remove the allen plug in the center portion of the hub. (fig. 11-45)



22. Add 1 oz. of ASV 10W-30 Heavy Duty Engine Oil to the hub as shown, then reinstall the plug and tighten. (fig. 11-46)
23. The hub assembly is now ready to be reinstalled. To install it onto the machine, reverse steps 1-3 on page 11-7 of this procedure. Make sure to read the note below step 3 prior to reinstalling.
24. Repeat this procedure throughout the undercarriage as necessary to repair worn or damaged components and restore proper function.

12. Loader Disassembly and Assembly

Chapter Overview

This chapter provides disassembly and assembly procedures for the loader assembly.

Personal Safety

! WARNING !

Improper operation, lubrication, maintenance or repair of this product can be dangerous and could result in injury or death.

Do not operate or perform any lubrication, maintenance or repair on this product until you have read and understood the operation, lubrication, maintenance and repair information.

Before starting any disassembly or assembly procedures, refer to *Chapter 1. Product Safety – Basic Precautions* for personal safety information.

Machine Preparation

! WARNING !

Accidental machine starting can cause injury or death to personnel working on the machine.

To avoid accidental machine starting, disconnect the battery cables from the battery, tape the clamps and remove the key.

Place a “Do Not Operate” tag prominently on the machine to inform personnel that the machine is being worked on.

Before starting any disassembly or assembly procedures, refer to *Chapter 1. Product Safety – Repair* for machine preparation information.

Preliminary Checkout

If troubleshooting is required prior to disassembly or assembly, refer to *Chapter 15. Troubleshooting*.

Loader Disassembly and Assembly Procedures

Disassembly and assembly procedures are provided for the following loader components.

- Lift Cylinders
- Tilt Cylinders
- Low-Flow Relief Valve

Note: Procedures are provided for only those loader components listed above. However, information for removal and installation of other loader components can be obtained from the Rubber Track Loader Parts manual.

Lift Cylinder/Tilt Cylinder Removal and Installation

The tools required for lift cylinder removal and installation are listed in Table 12-1. Use manufacturer-recommended tools whenever possible.

Table 12-1

Required Tools
Combination Wrench
Socket Wrench

Lift Cylinder/Tilt Cylinder Removal

Note: Since the procedures for removing the lift cylinders and tilt cylinders are identical, only the lift cylinder procedure is described below.

! WARNING !

Hot oil can cause personal injury. Lower all attachments and make sure the oil is cool before removing any components or lines.

Remove the oil filler cap only when the engine is stopped and the machine has been allowed to cool thoroughly.

Rubber Track Loader
12. Loader Disassembly and Assembly

NOTICE

Collect and contain liquids in a suitable container. Dispose of all liquids according to local regulations and mandates.

Note: During disassembly, cap all hoses and fittings to prevent fluid loss and contamination of the system fluids.

1. Lower the loader arms onto a jackstand with the arms resting about 6 inches off the ground.
2. Turn the ignition switch to the OFF position.

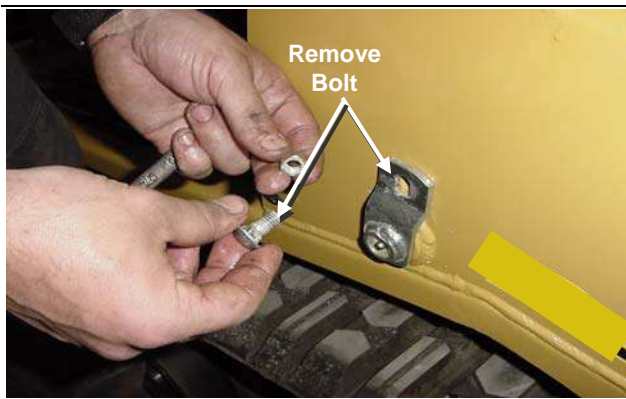

Figure 12-1 12-001

3. Remove the bolt on the pin assembly on the loader tower.



Figure 12-2 12-002

4. Remove the pin assembly.

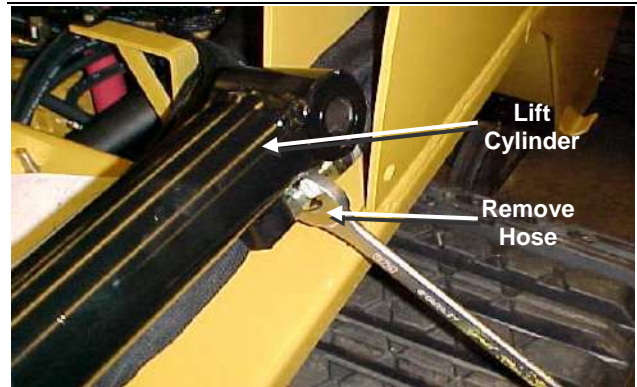

Figure 12-3 12-003

5. Remove and cap the hose on the base end of the cylinder.



Figure 12-4 12-004

6. Remove and cap the hose on the loader end of the cylinder.

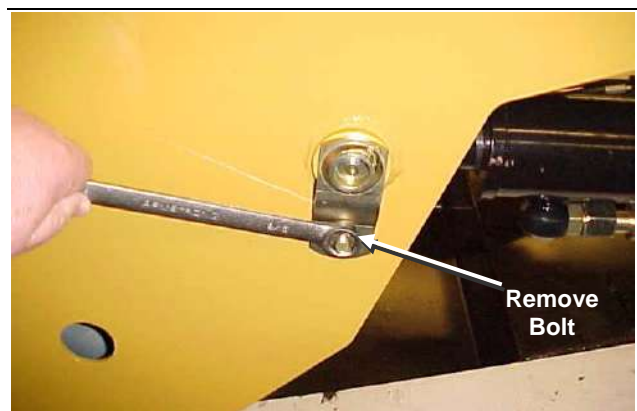

Figure 12-5 12-005

7. Remove the forward pin assembly bolt.

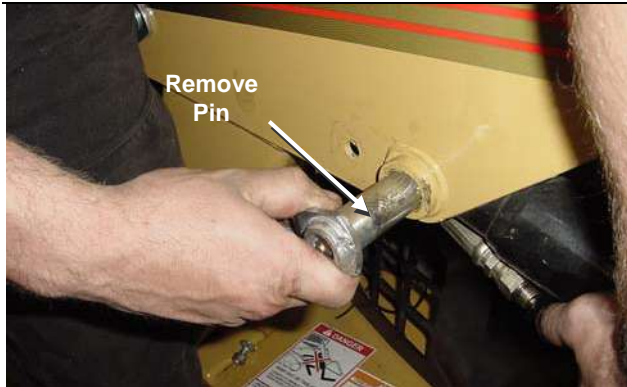

Figure 12-6

12-006

8. Remove the forward pin assembly.



Figure 12-7

12-007

9. Remove the lift cylinder from the machine.

Lift Cylinder/Tilt Cylinder Installation

Note: Reverse the above steps to install the cylinder.

Note: Begin the lift cylinder installation with the loader arms lowered and resting about 6 inches off the ground on a jack stand. This is the position the loader arms were in following lift cylinder removal.

Quick-Coupler Block / Pressure Release Valve Removal and Installation

The tools required for low-flow relief valve removal and installation are listed in Table 12-2. Use manufacturer-recommended tools whenever possible.

Table 12-2

Required Tools
Combination Wrench
Socket Wrench

Pressure Release Valve Removal

! WARNING !

Hot oil can cause personal injury. Lower all attachments and make sure the oil is cool before removing any components or lines.

NOTICE

Collect and contain liquids in a suitable container. Dispose of all liquids according to local regulations and mandates.

Note: During disassembly, cap all hoses and fittings to prevent fluid loss and contamination of the system fluids.

1. Lower the lift arms to the ground.
2. Turn the ignition switch to the OFF position.

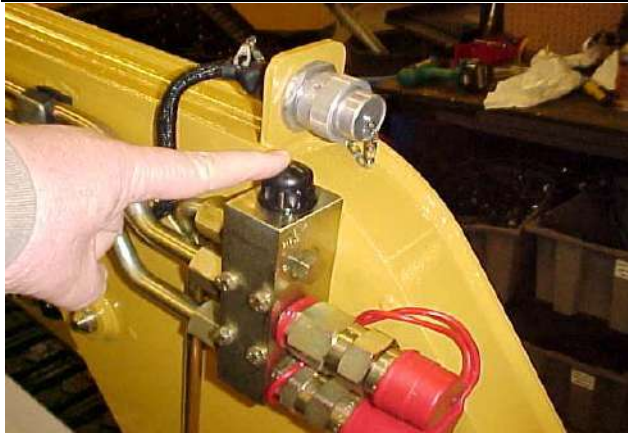

Figure 12-8 12-008

3. Press the button on top of the valve to release hydraulic pressure.



Figure 12-9 12-009

4. Remove and cap all hoses.

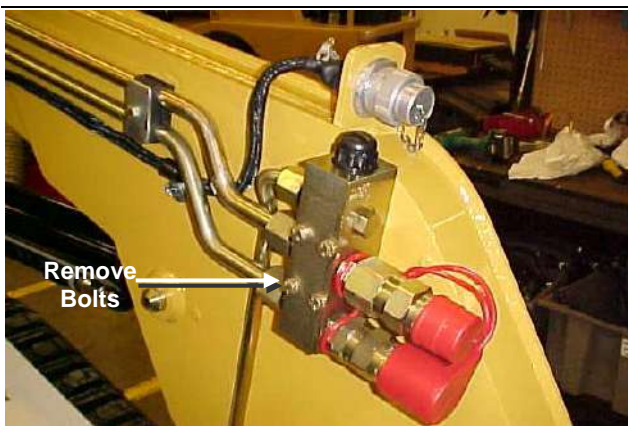

Figure 12-10 12-009

5. Remove the four bolts that secure the low-flow relief valve to the loader frame and remove the valve.

Quick Coupler Block / Pressure Release Valve Installation

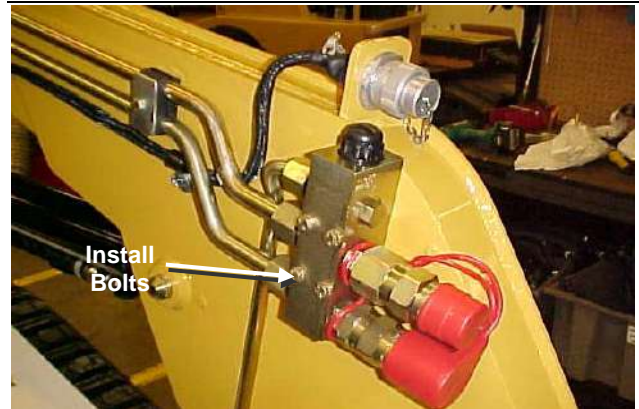

Figure 12-11 12-009

1. Install the four bolts that secure the low-flow relief valve to the loader frame.



Figure 12-12 12-009

2. Install all hoses.

13. Maintenance

Chapter Overview

This chapter contains maintenance requirements and procedures for the following Rubber Track Loader components.

- Engine oil
- Hydraulic fluid and filter
- Fuel separator and filter
- Track tension
- Air cleaner
- Fuse box
- Grease fittings
- Fuel bleeding

The general maintenance schedule for the Rubber Track Loader is listed in the table below.

Item	Frequency	Lubricant	Capacity
Hydraulic Fluid	500 hrs	ASV Hydraulic Oil , or Rykon MV	8 gal/30 l
Hydraulic Filter	250 hrs		
Engine Oil	250 hrs	ASV HD Diesel Engine Oil , or other	2.8 gal/10.6 l
Engine Filter	250 hrs		
Fuel Filter	500 hrs		
Primary Air Filter	Check daily, clean and reuse as needed up to 5 times; change at least once per year		
Secondary Air Filter	Every 3 cleanings of primary filter		
Grease Fittings	10 hrs	ASV Lithium Grease	
Track Tension	As needed		
Coolant	Test for coolant additive at 250 hrs. Change at 1000 hrs or two years		

NOTICE

When replacing engine coolant, use **ASV Long Life 50/50 Antifreeze/Coolant**, Caterpillar Extended Life Coolant or equivalent antifreeze with the proper SCA (Supplemental Cooling Additive)

Engine Oil

Regular oil changes are necessary to maintain a strong running engine. ASV recommends a normal oil change interval of 250 hours or every six months. This recommendation has been made to help ensure proper lubrication during operation and to prolong engine life under typical operating conditions.

Oil Change Procedures

1. Run the engine for a few minutes to warm the engine oil.

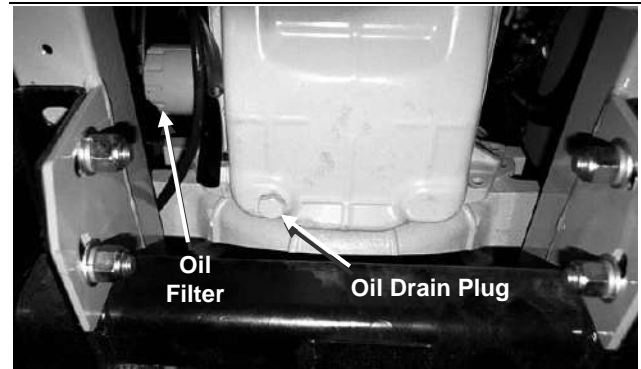

Figure 16-1

16-001

2. Remove the drain plug from the bottom of the engine.
3. Drain oil into suitable container.
4. Remove engine oil filter, making sure the gasket is also removed.
5. Put some fresh oil on the new filter gasket and install new filter.
6. Tighten filter to specifications on filter label.
7. Refill engine to capacity with oil, as specified.

Engine Oil Specifications

Due to the significant variations in the quality and performance of commercially available oils, ASV **Heavy Duty Diesel Engine Oil – 10W/30** is recommended. If ASV lubricants are not available, use a substitute meeting the following qualifications:

- API CH-4 multi-grade engine oil

Hydraulic Fluid and Filter

The hydraulic fluid should be changed every 500 service hours, and the hydraulic filter should be changed every 250 hours. Hydrostatic components require extremely clean oil for long service life.

Hydraulic Fluid and Filter Change Procedures

! WARNING !

Hot oil can cause personal injury. Make sure the oil is cool before removing any components or lines.

Remove the oil filler cap only when the engine is stopped and the machine has been allowed to cool thoroughly.

NOTICE

Extreme care must be taken when changing the hydraulic fluid. Before starting the procedure, make sure the machine is in a clean working environment. Precautions should be taken to prevent any debris from entering the hydrostatic system.

NOTICE

Collect and contain liquids in a suitable container. Dispose of all liquids according to local regulations and mandates.



Figure 16-2

16-002

1. Locate and remove the hydraulic fluid drain plug and drain the fluid into a suitable container.

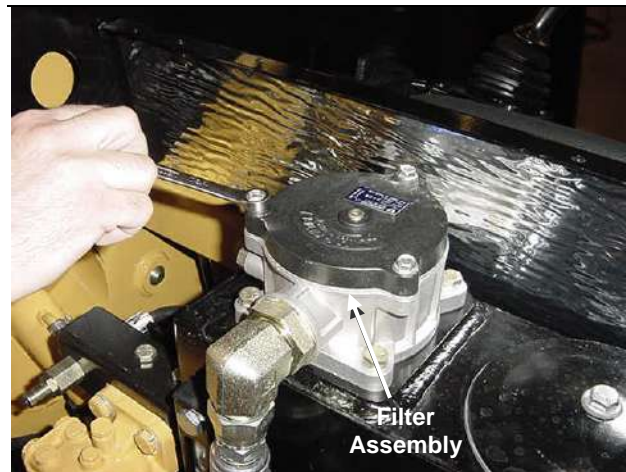

Figure 16-3

16-015

2. Clean the area around the filter assembly, which is located on the top of the hydraulic reservoir.

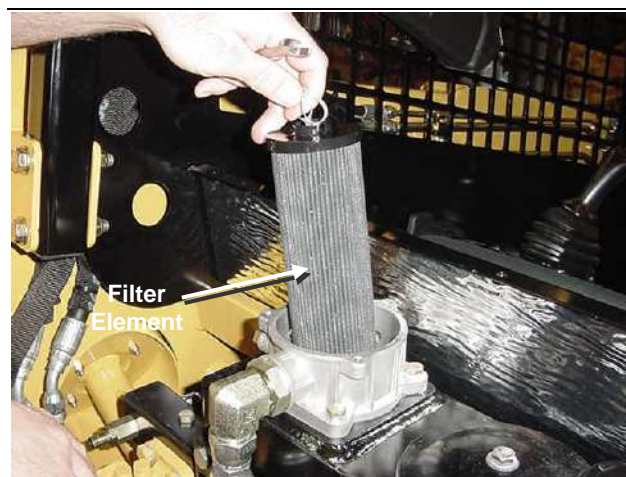

Figure 16-4

16-003

3. Turn the hydraulic filter counter clockwise and remove the filter
4. Change the filter element and replace the filter in the tank.
5. Fill with manufacturer-approved hydraulic fluid.

Fuel-Water Separator



To drain the fuel/water separator:

1. Loosen the twist valve on the bottom of the plastic catch bowl.
2. Allow all of the water to drain from the bowl, then retighten the valve to close it.

Fuel Filter

The fuel filter should be changed every 500 service hours, or as needed. A plugged fuel filter can cause loss of engine power, rough running, or no start.

NOTICE

Collect and contain liquids in a suitable container. Dispose of all liquids according to local regulations and mandates.

Fuel Filter Change Procedures



Figure 16-5

16-004

1. Clean the outside of the filter thoroughly.

2. Remove the bolt on the top of the assembly, then slide the filter and retainer down and off of the assembly.
3. Install the new filter by reversing step 2.
4. Bleed the fuel system according to the procedure at the end of this chapter.

Fuel Specifications

In North America, diesel fuel distilled from crude oil and identified as NO. 1-D or No. 2-D in "ASTM D975" generally meets the proper specifications.

Air Cleaner

The air cleaner is one of the most important maintenance items on the machine. A poorly maintained air cleaner can seriously shorten the life of the engine.

Air Filter Change Procedures

NOTICE

When working in dusty conditions, the air cleaner elements should be checked and changed more frequently than when working under normal conditions.

NOTICE

Do not clean the primary air cleaner element by bumping and tapping. This could damage the seals. Do not use elements with damaged pleat gaskets or seals.

1. Open the hood, release the latches on either side of the air cleaner, and then remove the cover.

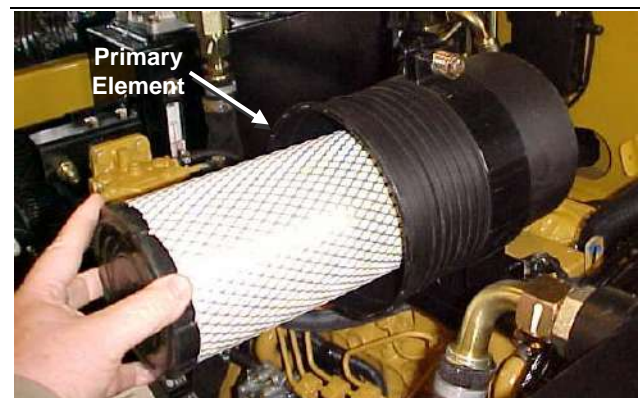

Figure 16-6

16-010

2. Remove the primary element. The primary element can be cleaned and reused up to five times, but it should be changed at least once a year.

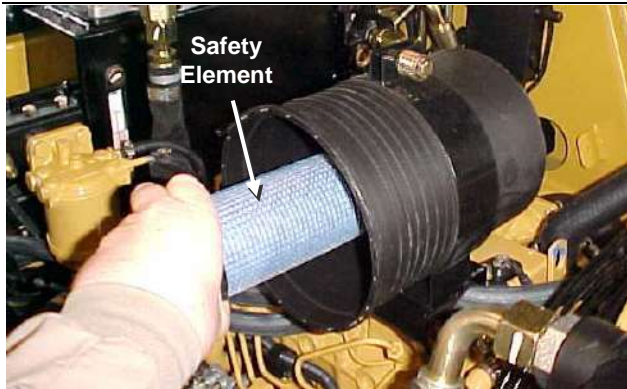

Figure 16-7

16-011

3. Remove the safety element. The safety element is not serviceable or washable. It should be replaced with every three cleanings of the primary element.

Track Tension

Proper track tension is very important for optimum performance and long track life. Tracks that are run too loose can cause misfeeding and ratcheting possibly causing damage to the track. During the first 50 hours of operation, the tracks will “break in” and will most likely require adjustment.

Track Tension Adjustment Procedures

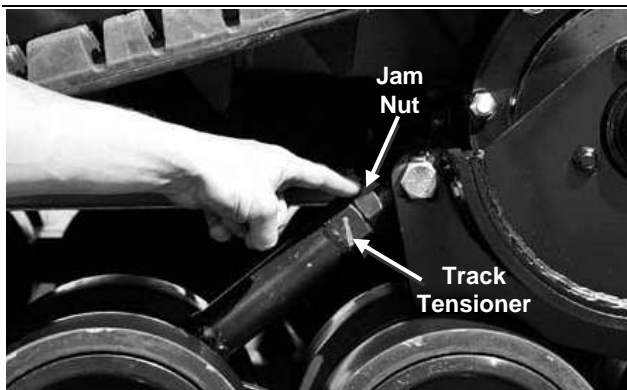

Figure 16-8

16-005

1. Locate the jam nut on the track tensioner and clean the threads thoroughly before proceeding.
2. Loosen the jam nut. You can use the wrench supplied with the machine, but a standard wrench is preferred for shop use.



Figure 16-9

16-007

3. After loosening the jam nut, turn the track tensioner until the track tension is within specifications.
4. Once proper tension is achieved, retighten the jam nut

Checking for Proper Track Adjustment

1. Drive the machine forward five feet to remove any slack from the lower and rearward portions of the track.



Figure 16-10

16-008

2. Lay a straightedge along the top of the track between the sprocket and the front idler wheel.
3. Using a rope or wire, put 50 pounds of down force on the track at the midpoint of the straightedge.



Figure 16-11

16-009

4. Using a ruler, measure the distance between the straightedge and track. The track should not deflect more than 0.75" between the top of the track and the straightedge.
5. If the track deflects more than 0.75", tighten the track between 0.50" and 0.75".

Fuse Box



Figure 16-12

16-012

The fuse box is located on the left side of the engine compartment. The machine should never be operated with the fuse box cover removed.

Grease Fittings

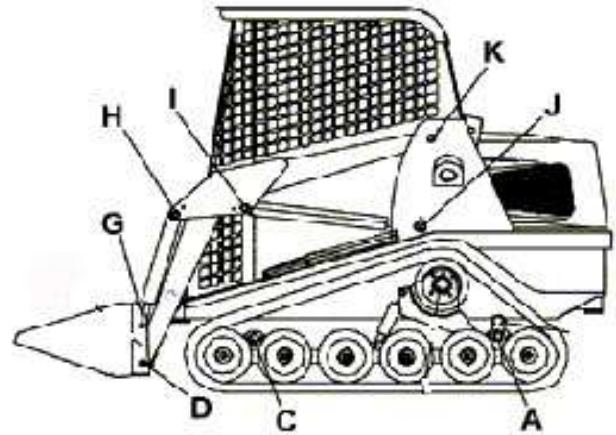

Figure 16-13

16-013

The locations of the grease fittings for the left side of the machine are shown above. An identical set of fittings is located on the right side of the machine. These fitting should be lubricated at least after every 10 hours of operation using **ASV Multi Purpose EP Lithium Grease**.

Bleeding the Fuel System

The tools required for bleeding the fuel system are listed below. Use manufacturer-recommended tools whenever possible.

Table 16-1

Required Tools
Combination Wrench

If the machine has been run out of fuel, it may be necessary to bleed the fuel system.

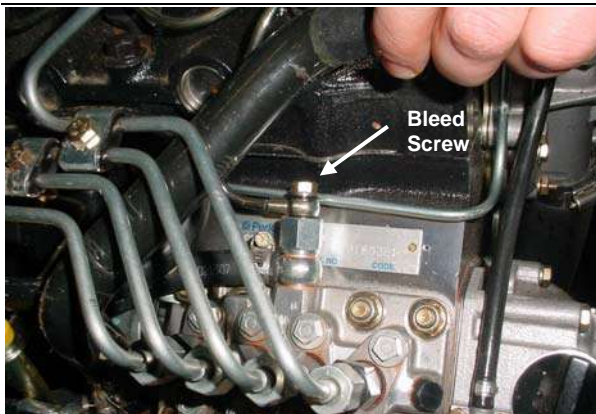

Figure 11-25

11-006

1. Locate the bleed screw directly above the fuel injection pump.
2. Loosen the bleed screw two full turns.



Figure 11-27

11-004

3. Pump the bulb primer with your hand until fuel flows from the bleed screw without any air bubbles.
4. Tighten the bleed screw.

14. Hydraulic Pressure Check & Adjustment

Chapter Overview

This chapter provides an overview of checking and setting pressures. It is important to contact the manufacturer for assistance before beginning these procedures.

Personal Safety

! WARNING !

Improper operation, lubrication, maintenance or repair of this product can be dangerous and could result in injury or death.

Do not operate or perform any lubrication, maintenance or repair on this product until you have read and understood the operation, lubrication, maintenance and repair information.

Before starting any disassembly or assembly procedures, refer to *Chapter 1. Product Safety – Basic Precautions* for personal safety information.

Machine Preparation

! WARNING !

Accidental machine starting can cause injury or death to personnel working on the machine.

To avoid accidental machine starting, disconnect the battery cables from the battery, tape the clamps and remove the key.

Place a “Do Not Operate” tag prominently on the machine to inform personnel that the machine is being worked on.

Before starting any disassembly or assembly procedures, refer to *Chapter 1. Product Safety – Repair* for machine preparation information.

Hydraulic Pressure Adjustment Procedures

Adjustment and test procedures are provided for the following transmission and drive components.

- Charge Pressure Check & Adjustment
- Auxiliary Valve Pressure Check & Adjustment

Charge Pressure Check

The service tools required for the charge pressure check are listed in Table 14-1. Use manufacturer-recommended tools whenever possible.

Table 14-1

Required Tools
Pressure Gauge
Combination Wrench

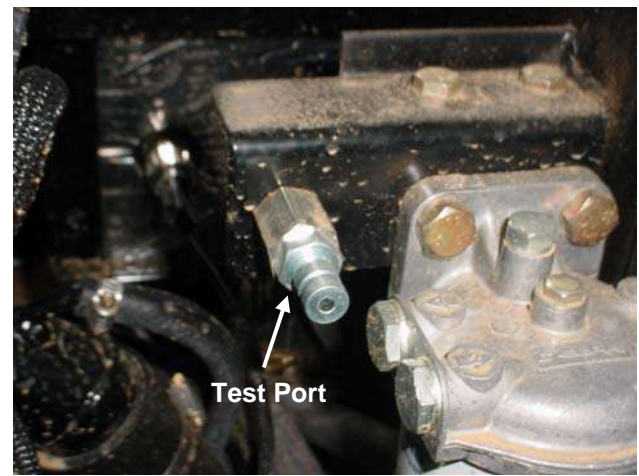

Figure 14-1

14-101

14. Hydraulic Pressure Check & Adjustment



Figure 14-2

14-102

1. Attach the gauge to the charge pressure test port, located next to the fuel filter.
2. Start the engine.
3. Check the pressure with the engine at wide open throttle. Make sure the engine is properly warmed up before running wide open. Charge pressure should be between 400 and 450 psi.
4. Turn the ignition switch to the OFF position.
5. Remove the gauge from the test port.

Auxiliary Pressure Check & Adjustment

The service tools required for the auxiliary pressure check and adjustment are listed in Table 14-1. Use manufacturer-recommended tools whenever possible.

Table 14-2

Required Tools
Pressure Gauge
Allen Wrench



Figure 14-3

14-110

Insert the hydraulic gauge into one of the attachment quick couplers.

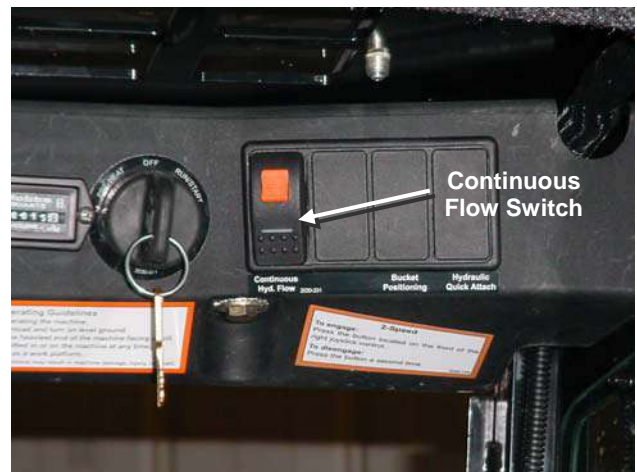

Figure 14-4

14-111

1. Engage the continuous flow switch next to the key switch. Make sure it is in the direction that sends flow to the gage.
2. There must be an operator in the seat with the lap bar down for the flow to work.
3. Pressure should be approximately 3000 psi.

14. Hydraulic Pressure Check & Adjustment

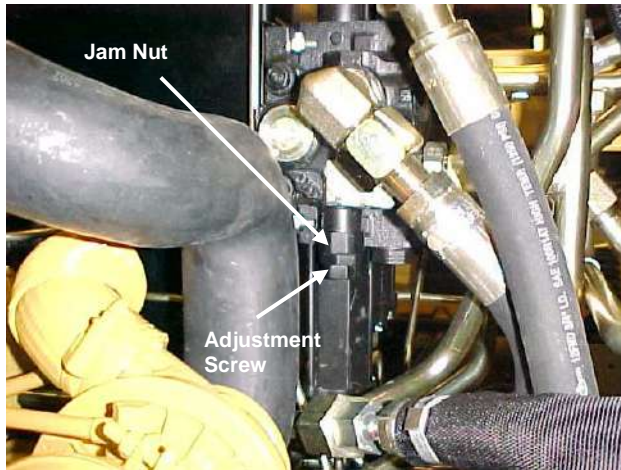

Figure 14-5

14-113

4. To adjust the auxiliary pressure, loosen the jam nut and turn the adjustment screw in with an allen wrench to increase pressure and turn screw out to decrease pressure. Tighten jam nut when after adjustment has been made. **DO NOT exceed 3,000 psi.**

15. Troubleshooting

Chapter Overview

This chapter contains basic troubleshooting procedures for the Rubber Track Loader.

Additional troubleshooting aids are provided in *Chapter 3. System Diagrams* and in those chapters containing disassembly and assembly procedures for the appropriate component or assembly.

Personal Safety

! WARNING !

Improper operation, lubrication, maintenance or repair of this product can be dangerous and could result in injury or death.

Do not operate or perform any lubrication, maintenance or repair on this product until you have read and understood the operation, lubrication, maintenance and repair information.

Before starting any troubleshooting procedures, refer to *Chapter 1. Product Safety – Basic Precautions* for personal safety information.

Machine Preparation

! WARNING !

Accidental machine starting can cause injury or death to personnel working on the machine.

To avoid accidental machine starting, disconnect the battery cables from the battery, tape the clamps and remove the key.

Place a “Do Not Operate” tag prominently on the machine to inform personnel that the machine is being worked on.

Before starting any troubleshooting procedures, refer to *Chapter 1. Product Safety – Repair* for machine preparation information.

Preliminary Checkout

A simple visual inspection and operational check can identify many problems without the need for extensive troubleshooting. If these checks indicate a problem that requires further analysis, proceed to *Troubleshooting* in this section.

Visual Inspection

Prior to troubleshooting, do a walk-around and perform a visual inspection of the machine. Look for missing, loose or worn parts. Perform the following visual checks.

- Track tension
- Fluid levels
- Fan belt tension and condition
- Hoses (no visible sign of wear)
- Fittings (no leaks)
- Battery cables
- Fuse box (fuses in place and operational)
- Controls (for neutral)

Troubleshooting

This section identifies selected problems and suggests probable causes.

Problem 1

Machine will not crank over.

Probable cause

1. Continuous hyd. flow switch activated.
2. Weak or dead battery.
3. Faulty continuous hyd. flow switch
4. Battery cables loose or corroded.
5. Ignition fuse blown.
6. Main starter fuse blown.
7. Starter relay malfunctioning.
8. Bad ignition switch.
9. Bad starter.
10. Poor wire connections at key, relay, or starter.

Problem 2

Machine cranks but will not start.

Probable cause

1. Injection pump fuse blown.
2. Main power fuse B blown.
3. Main power relay B not activating.
4. Poor wire connection at injection pump or fuse.
5. Glow plugs not heating. (Will see black smoke.)
 - a) Main glow plug fuse blown.
 - b) Glow plug relay not activating.
 - c) Poor wire connections at ignition switch, relay, or glow plug strip.
 - d) Failed glow plugs.
 - e) Bad ignition switch.

Problem 3

Machine starts but hydraulics will not operate.

Probable cause

1. Lap bar must be in down position, operator must be seated in seat, and front door (if installed) must be closed.
2. Safety fuse blown.
3. Faulty operator presence switch.
 - a) Test continuity through seat, lap bar, and door switch. Adjust or replace as necessary. Lap bar and door switch are magnetic switches and should be adjusted to approximately 1/16 inch away from steel pickup bracket.
4. Poor ground (check ground wires on bottom left rear side of hydraulic reservoir).
5. Safety relay is not activating.
6. Faulty safety solenoid or safety solenoid spool.
7. Poor wire connections on fuse, relay, or safety solenoid.
8. Low charge pressure.

Problem 4

Loader operates but tracks will not move.

Probable cause

1. Leak in feed line to pilot control.
2. Pilot control malfunctioning.
3. Low pilot pressure.

Problem 5

Tracks operate but loader will not operate.

Probable cause

1. Continuous hyd. flow switch activated, sending oil over relief.
2. Check to see if auxiliary flow works. (If auxiliary flow works, skip to number 5).
3. Main auxiliary relief malfunction.
4. Auxiliary pump bad.
5. Leak in feed line to loader control pilot.
6. Loader control pilot malfunctioning.
7. Loader valve malfunctioning.

Problem 6

Auxiliary flow does not work. Loader works.

Probable cause

1. Auxiliary hydraulic fuse blown.
2. Faulty ground wire.
 - a) Clean ground connections on left rear side of hydraulic tank.
3. Auxiliary hydraulic switch failure.
4. Poor wire connections at fuse, auxiliary hyd. switch, or pin connector P17.
5. Auxiliary hydraulic pilot generation spool stuck.
6. Bad or not fully connected Quick-Coupler

Problem 9

Auxiliary hydraulics will only flow one way. Try both continuous flow and intermittent thumb switch.

Probable cause

1. Auxiliary hydraulic relay 1 or 2 failure.
2. Auxiliary hydraulic pilot generation coil faulty.
3. Auxiliary hydraulic pilot generation spool faulty.
4. Poor wire connections at relay, pilot generation solenoid, pin connector P16 or P21.
5. Loader valve malfunction.

Problem 10

No power to numerous auxiliary functions or accessories in ON or RUN position.

Probable cause

1. Main power relay A or B fuse blown.
2. Main relay A or B faulty.
3. Ignition switch malfunction.
4. Poor wire connections at ignition switch, fuse, or relay.

Problem 11

Battery will not charge and/or battery goes dead.

Probable cause

1. Alternator fuse blown.
2. Alternator diode bad.
3. Poor wire connections at battery, alternator, diode, or fuse.
4. Excessive draw in off position.
 - a) Fuel gauge and hour meter should draw only 0.01 amps in off position.
5. Bad battery.
6. Bad alternator.

Problem 12

Loader control will not lock in float position.

Probable cause

1. Float magnet fuse blown.
2. Poor wire connections at fuse, float detent magnet, or pin connector P18.
3. Faulty float detent magnet.

Problem 13

Loader will not float; labors engine and has down pressure when detented into float.

Probable cause

1. Engine RPM too low.
2. Low charge pressure.
3. Pilot control malfunction.
4. Loader valve malfunction.

Problem 14

Hot oil light illuminates; hydraulic system operating hot.

Probable cause

1. Auxiliary hydraulic switch activated sending oil over relief.
2. Low oil level.
3. Debris plugging oil cooler limiting airflow.
4. Broken fan blades.
5. Loose fan belt.
6. Improper attachment.
 - a) Attachment must be rated at a minimum of 16.3 gallons per minute and 3000 PSI.
 - b) Attachment hose size must be a minimum of 1/2 inch.
7. Faulty hot oil sending unit.
 - a) Hot oil light should illuminate at 225°F.
8. Faulty quick coupler.
9. Cooler bypass relief.
 - a) Cooler bypass relief should open at 80 PSI.

Problem 15

Track makes popping noise.

Probable cause

1. Track too loose. (Refer to track adjustment section.)
2. Worn or stuck drive teeth. Outer roller should pivot as lug comes into sprocket.
3. Loose or worn sprocket.
4. Worn track lugs.

Terex Construction Americas

8800 Rostin Road

Southaven, MS 38671

(888)-201-6008

(662)-393-1800

www.terex.com