

Language: English  
Geographic Region: All  
Serial Number Range: SN All



# RC30

## Service Repair Manual

This manual is complements of  
TrackLoaderParts.com

The world's best source for ASV parts.



# Table of Contents

## 1. Product Safety

Chapter Overview .....	1-1
Safety Messages.....	1-1
Information Messages .....	1-1
Basic Precautions .....	1-1
Safety Signs.....	1-1
Protective Equipment.....	1-2
Mounting and Dismounting .....	1-2
Lifting .....	1-2
Hot Fluids and Parts .....	1-2
Corrosion Inhibitor .....	1-2
Batteries .....	1-2
Pressurized Items .....	1-2
Repair .....	1-3
Work Tools.....	1-3
Asbestos Information .....	1-4
Machine Labels and Decals .....	1-4
Product ID Number .....	1-4
Machine Label and Decal Examples.....	1-5

## 2. Technical Specifications

Chapter Overview .....	2-1
Specifications .....	2-1
Engine .....	2-1
Transmission .....	2-1
Drive Motors .....	2-1
Control Handles .....	2-1
Auxiliary Pump.....	2-1
Loader Valve.....	2-1
Cooler .....	2-1

## 3. System Diagrams

Chapter Overview .....	3-1
Filtering and Cooling System .....	3-1
Auxiliary Circuit System .....	3-2
Drive Loop System.....	3-3

## 4. Machine Controls and Instrumentation

Chapter Overview .....	4-1
Machine Controls .....	4-1
Loader Control .....	4-1
Drive Control.....	4-1
Throttle .....	4-1
Dash Panel .....	4-1
Gauge/Warning Light Panel .....	4-2

## 5. Operator Enclosure Disassembly and Assembly

Chapter Overview .....	5-1
Personal Safety.....	5-1
Machine Preparation .....	5-1
Preliminary Checkout .....	5-1
Operator Enclosure Disassembly and Assembly Procedures.....	5-1
Light Bar Removal and Installation.....	5-1
Light Bar Removal .....	5-1
Light Bar Installation .....	5-2
Ignition Switch Removal and Installation .....	5-2

Ignition Switch Removal .....	5-2
Ignition Switch Installation .....	5-3
Console Gauge/Warning Panel Removal and Installation.....	5-4
Console Gauge Removal.....	5-4
Console Gauge Installation.....	5-4
Lap Bar Gas Assist Spring Removal and Installation.....	5-5
Lap Bar Gas Assist Spring Removal .....	5-5
Lap Bar Gas Assist Spring Installation .....	5-5

## 6. Chassis Disassembly and Assembly

Chapter Overview .....	6-1
Personal Safety.....	6-1
Machine Preparation .....	6-1
Preliminary Checkout .....	6-1
Chassis Disassembly and Assembly Procedures.....	6-1
Seat Removal and Installation .....	6-1
Seat Removal .....	6-1
Seat Installation .....	6-2
Fuel Sending Unit Removal and Installation .....	6-2
Fuel Sending Unit Removal .....	6-3
Fuel Sending Unit Installation .....	6-4
Fuel Tank Removal and Installation.....	6-4
Fuel Tank Removal .....	6-4
Fuel Tank Installation.....	6-6

## 7. Radiator/Oil Cooler Disassembly and Assembly

Chapter Overview .....	7-1
Personal Safety.....	7-1
Machine Preparation .....	7-1
Preliminary Checkout.....	7-1
Radiator/Oil Cooler Disassembly and Assembly Procedures.....	7-1
Fan Guard Removal and Installation.....	7-1
Fan Guard Removal .....	7-2
Fan Guard Installation .....	7-2
Fan and Fan Shroud Removal and Installation.....	7-2
Fan and Fan Shroud Removal.....	7-2
Fan and Fan Shroud Installation.....	7-3
Radiator/Cooler Removal and Installation.....	7-4
Radiator/Cooler Removal .....	7-4
Radiator/Cooler Installation .....	7-6
Radiator/Oil Cooler Adjustment Procedures .....	7-7
Fan Shroud Adjustment.....	7-7
Fan Guard Adjustment.....	7-8

## 8. Hydraulic Reservoir Disassembly and Assembly

Chapter Overview .....	8-1
Personal Safety.....	8-1
Machine Preparation .....	8-1
Preliminary Checkout .....	8-1
Hydraulic Reservoir Disassembly and Assembly Procedures.....	8-1
Filter Element Removal and Installation.....	8-1

Filter Assembly Removal and Installation .....	8-1
Filter Assembly Removal .....	8-2
Filter Assembly Installation .....	8-3
Filler Cap Assembly Removal and Installation .....	8-4
Filler Cap Assembly Removal .....	8-4
Filler Cap Assembly Installation .....	8-5
Access Cover Removal and Installation .....	8-5
Access Cover Assembly Removal .....	8-6
Access Cover Assembly Installation .....	8-6
Reservoir Gauge Removal and Installation .....	8-7
Reservoir Gauge Removal .....	8-7
Reservoir Gauge Installation .....	8-8
Suction Screen Removal and Installation .....	8-8
Suction Screen Removal .....	8-8
Suction Screen Installation .....	8-9
Hydraulic Reservoir Cleaning Procedures .....	8-9
Hydraulic Reservoir Cleaning .....	8-9
<b>9. Loader/Transmission Controls Disassembly and Assembly</b>	
Chapter Overview .....	9-1
Personal Safety .....	9-1
Machine Preparation .....	9-1
Preliminary Checkout .....	9-1
Loader/Transmission Controls Disassembly and Assembly Procedures .....	9-1
Loader Control Joystick/Drive Control Joystick Removal and Installation .....	9-1
Loader Control Joystick/Drive Control Joystick Removal .....	9-2
Loader Control Joystick/Drive Control Joystick Installation .....	9-3
Loader Float Magnet Removal and Installation .....	9-4
Loader Float Magnet Removal .....	9-4
Loader Float Magnet Installation .....	9-6
Loader Valve Removal and Installation .....	9-7
Loader Valve Removal .....	9-7
Loader Valve Installation .....	9-9
<b>10. Transmission and Drive Disassembly and Assembly</b>	
Chapter Overview .....	10-1
Personal Safety .....	10-1
Machine Preparation .....	10-1
Preliminary Checkout .....	10-1
Transmission and Drive Disassembly and Assembly Procedures .....	10-1
Brake Cylinder Removal and Installation .....	10-1
Drive Motor Removal and Installation .....	10-1
Auxiliary Gear Pump Removal and Installation .....	10-2
Auxiliary Gear Pump Removal .....	10-2
Auxiliary Gear Pump Installation .....	10-3
Tandem Pump Removal and Installation .....	10-4
Tandem Pump Removal .....	10-4
Tandem Pump Installation .....	10-5
Pump Drive Coupler Removal and Installation .....	10-6
Pump Drive Coupler Removal .....	10-6
Pump Drive Coupler Installation .....	10-7

<b>11. Engine Components Disassembly and Assembly</b>	
Chapter Overview .....	11-1
Personal Safety .....	11-1
Machine Preparation .....	11-1
Preliminary Checkout .....	11-1
Engine Components Disassembly and Assembly Procedures .....	11-1
Primary Air Filter Removal and Installation .....	11-1
Safety Air Filter Removal and Installation .....	11-1
Engine Oil Filter Removal and Installation .....	11-1
Fuel Filter Removal and Installation .....	11-2
Muffler Removal and Installation .....	11-2
Muffler Removal .....	11-2
Muffler Installation .....	11-2
Exhaust Pipe Removal and Installation .....	11-3
Exhaust Pipe Removal .....	11-3
Exhaust Pipe Installation .....	11-4
Battery Removal and Installation .....	11-5
Battery Removal .....	11-5
Battery Installation .....	11-6
Bleeding the Fuel System .....	11-7
<b>12. Undercarriage Disassembly and Assembly</b>	
Chapter Overview .....	12-1
Personal Safety .....	12-1
Machine Preparation .....	12-1
Preliminary Checkout .....	12-1
Undercarriage Disassembly and Assembly Procedures .....	12-1
Wheel Removal and Installation .....	12-1
Wheel Removal .....	12-2
Wheel Installation .....	12-3
Sprocket Roller Removal and Installation .....	12-3
Sprocket Roller Removal .....	12-4
Sprocket Roller Installation .....	12-4
Brake Removal and Installation .....	12-4
Brake Removal .....	12-5
Brake Installation .....	12-5
Track Removal and Installation .....	12-6
Track Removal .....	12-6
Track Installation .....	12-8
Sprocket Bearing Plate Removal and Installation .....	12-9
Sprocket Bearing Plate Removal .....	12-9
Sprocket Bearing Plate Installation .....	12-11
Sprocket Removal and Installation .....	12-12
Sprocket Removal .....	12-12
Sprocket Installation .....	12-13
Drive Motor Removal and Installation .....	12-13
Drive Motor Removal .....	12-13
Drive Motor Installation .....	12-14
<b>13. Loader Disassembly and Assembly</b>	
Chapter Overview .....	13-1
Personal Safety .....	13-1
Machine Preparation .....	13-1
Preliminary Checkout .....	13-1
Loader Disassembly and Assembly Procedures .....	13-1
Lift Cylinder/Tilt Cylinder Removal and Installation .....	13-1
Lift Cylinder/Tilt Cylinder Removal .....	13-1
Lift Cylinder/Tilt Cylinder Installation .....	13-3

Low-Flow Relief Valve Removal and Installation ..13-5  
    Low-Flow Relief Valve Removal ..... 13-5  
    Low-Flow Relief Valve Installation ..... 13-6

**14. Quick Attach Disassembly and Assembly**

Chapter Overview .....14-1  
Personal Safety..... 14-1  
Machine Preparation ..... 14-1  
Preliminary Checkout ..... 14-1  
Quick Attach Disassembly and Assembly  
Procedures.....14-1  
Latch Pin Assembly Removal and Installation ..... 14-1  
    Latch Pin Assembly Removal ..... 14-1  
    Latch Pin Assembly Installation ..... 14-2  
Quick Attach Assembly Removal and Installation .14-3  
    Quick Attach Assembly Removal..... 14-3  
    Quick Attach Assembly Installation..... 14-4

**15. Troubleshooting**

Chapter Overview .....15-1  
Personal Safety..... 15-1  
Machine Preparation ..... 15-1  
Preliminary Checkout ..... 15-1  
    Visual Inspection..... 15-1  
    Operational Checks ..... 15-1  
Troubleshooting ..... 15-2

**16. Maintenance**

Chapter Overview .....16-1  
Maintenance Schedule..... 16-1  
Engine Oil ..... 16-1  
    Oil Change Procedures ..... 16-1  
    Engine Oil Specifications ..... 16-1  
Hydraulic Fluid and Filter ..... 16-2  
    Hydraulic Fluid and Filter Change  
    Procedures ..... 16-2  
Fuel Filter ..... 16-3  
    Fuel Filter Change Procedures ..... 16-3  
    Fuel Specifications..... 16-3  
Air Cleaner ..... 16-3  
    Air Filter Change Procedures..... 16-3  
Track Tension ..... 16-4  
    Track Tension Adjustment Procedures ..... 16-4  
    Checking for Proper Track Adjustment ..... 16-4  
Fuse Box..... 16-4  
Grease Fittings..... 16-5

**17. Hydraulic Pressure Check & Adjustment**

Charge Pressure check..... 17-1  
Charge Pressure Adjustment..... 17-2  
Drive Pressure Adjustment..... 17-3  
Auxiliary Pressure Check & Adjustment..... 17-4



# 1. Product Safety

## Chapter Overview

This chapter contains product safety information for the Rubber Track Loader. Read this chapter and understand all safety messages and information messages before attempting to service the machine.

## Safety Messages

Safety messages are provided in this document and on the machine. If these hazard warnings are not heeded, bodily injury or death could occur to you or other persons.

Hazards are identified by the Safety Alert Symbols **!DANGER! . . . !WARNING!....!CAUTION!**.

The meaning of these safety alerts is as follows:  
**Attention! Become Alert! Your Safety is Involved.**

The message that appears under a Safety Alert Symbol explains the hazard and can be either written or pictorially presented.

**! DANGER !**

This symbol is used to alert service personnel of an imminently hazardous situation that will result in serious injury or death.

**! WARNING !**

This symbol is used to alert service personnel of a potentially hazardous situation that could result in serious injury or death.

**! CAUTION !**

This symbol is used to alert service personnel of an unsafe practice that could result in injury.

## Information Messages

Information messages are provided in this document and on the machine. These messages are identified by the labels **NOTICE....Note**.

**NOTICE**

This label is used to alert service personnel to the possibility of damaging the equipment.

---

**Note:** This label is used to provide important additional information, comments, explanations or amplification of the accompanying subject matter.

---

The person servicing the Rubber Track Loader may be unfamiliar with many of the systems on the machine. This makes it important to use caution when performing service work. Knowledge of the system and/or components is important before the removal or disassembly of any component.

**It is not possible to anticipate every circumstance that might involve a potential hazard. The safety messages in this document and on the product are, therefore, not all inclusive. If you use a tool, procedure, work method or operating technique that is not specifically recommended by the manufacturer, you must satisfy yourself that it is safe for you and for others. You should also ensure that the product will not be damaged or be made unsafe by the operation, lubrication, maintenance or repair procedures that you choose.**

## Basic Precautions

**! WARNING !**

Improper operation, lubrication, maintenance or repair of this product can be dangerous and could result in injury or death.

**Do not operate or perform any lubrication, maintenance or repair on this product until you have read and understood the operation, lubrication, maintenance and repair information.**

Following is a list of basic precautions that should always be observed.

## Safety Signs

Read and understand all "Safety" signs on the product before operating, lubricating or repairing this product. Replace any damaged, illegible or missing safety plates, signs or decals.

## Protective Equipment

Always wear a hard hat, protective glasses, protective shoes and other protective equipment as required by job conditions when working around this product. In particular, wear protective glasses when pounding on any part of the product or its work tool with a hammer or sledge. Use welders gloves, hood/goggles, apron and other protective clothing appropriate to the welding job being performed. Do not wear loose clothing or jewelry that can catch on parts of the product.

## Mounting and Dismounting

Use steps and handholds when mounting or dismounting a machine. Clean any mud or debris from steps or work platforms before using them. Always face the machine when using steps and handholds. When it is not possible to use the designed access system, provide ladders, scaffolds, or work platforms to perform safe repair operations.

## Lifting

Use a hoist when lifting components that weigh 23 kg (50 lb) or more, to avoid back injury. Make sure all chains, hooks, slings, etc., are in good condition and are of the correct capacity. Be sure hooks are positioned correctly and equipped with a spring latch. Lifting eyes are not to be side loaded during a lifting operation.

## Hot Fluids and Parts

To avoid burns, be alert for hot parts on machines that have just been stopped and hot fluids in lines, tubes and compartments.

Be careful when removing fill caps, breathers and plugs on the machine. Hold a rag over the cap or plug to prevent being sprayed or splashed by liquids under pressure. The danger is even greater if the machine has just been stopped because fluids can be hot.

## Corrosion Inhibitor

Corrosion inhibitor contains alkali. Avoid contact with eyes. Avoid prolonged or repeated contact with skin. Do not take internally. In case of contact, wash skin immediately with soap and water. For eyes, flush with large amounts of water for at least 15 minutes. **Call Physician. Keep out of reach of children.**

## Batteries

Do not smoke when inspecting the battery electrolyte level. Never disconnect any charging unit circuit or battery circuit cable from the battery when the charging unit is operating. A spark can cause an explosion from the flammable vapor mixture of hydrogen and oxygen that is released from the electrolyte through the battery outlets. Do not let electrolyte solution make contact with skin or eyes. Electrolyte solution is an acid. In case of contact, immediately wash skin with soap and water. For eyes, flush with large amounts of water for at least 15 minutes. **Call Physician. Keep out of reach of children.**

## Pressurized Items

1. Always use a board or a piece of cardboard when you check for a leak. Leaking fluid under pressure can penetrate body tissue. Fluid penetration can cause serious injury and possible death. A pin hole leak can cause severe injury. If fluid is injected into your skin, get treatment immediately. Seek treatment from a doctor that is familiar with this type of injury.
2. Relieve all pressure in air, oil or water systems before disconnecting or removing any lines, fittings or related items. Always make sure all raised components are blocked correctly and be alert for possible pressure when disconnecting any device from a system that utilizes pressure.
3. Lower the bucket, blade, or other work tool to the ground before performing any work on the machine. If this cannot be done, make sure the bucket, blade, or other work tool is blocked correctly to prevent it from dropping unexpectedly.
4. Loose or damaged fuel, lubricant and hydraulic lines, tubes and hoses can cause fires. Do not bend or strike high-pressure lines or install ones that have been bent or damaged. Check lines, tubes and hoses carefully. Do not use your bare hand to check for leaks.
5. Pressurized air or water can cause personal injury. When pressurized air or water is used for cleaning, wear a protective face shield, protective clothing, and protective shoes. The maximum air pressure for cleaning purposes must be below 205 kPa (30 psi). When using a pressure washer, keep in mind that nozzle pressures are very high, generally pressures are well above 13790 kPa (2000 psi). Follow all recommended practices provided by the pressure washer manufacturer.

## Repair

### ! WARNING !

Accidental machine starting can cause injury or death to personnel working on the machine.

To avoid accidental machine starting, disconnect the battery cables from the battery and tape the battery clamps and remove the key.

Place a "Do Not Operate" tag prominently on the machine to inform personnel that the machine is being worked on.

1. Disconnect battery and discharge any capacitor before starting to work on the product. Attach a **Do Not Operate** tag in the Operator's Compartment.
2. If possible, make all repairs with the machine parked on a level, hard surface. Block the machine to prevent it from rolling while working on or under the machine.
3. Do not work on any machine that is supported only by lift jacks or a hoist. Always use blocks or jack stands to support the machine before performing any service or disassembly.
4. Make sure the work area around the product is made safe and be aware of hazardous conditions that may exist. If an engine is started inside an enclosure, make sure that the engine's exhaust is properly vented.
5. Be sure all protective devices including guards and shields are properly installed and functioning correctly before starting a repair. If a guard or shield must be removed to perform the repair work, use extra caution.
6. Always use tools that are in good condition and be sure you understand how to use them before performing any service work.
7. Replace all fasteners with the same part number. Do not use a lesser quality fastener if replacements are necessary.
8. Be prepared to stop an engine if it has been recently overhauled or the fuel system has been recently worked on. If the engine has not been assembled correctly, or if the fuel settings are not correct, the engine can possibly overspeed and cause bodily injury, death or property damage. Be prepared to shut off the fuel and air supply to the engine in order to stop the engine.
9. Be careful when removing cover plates. Gradually back off the last two bolts or nuts located at opposite ends of the cover or device. Then, pry the cover loose to relieve any spring or other pressure before removing the last two nuts or bolts completely.
10. Repairs requiring welding should be performed only with the benefit of the appropriate reference information and by personnel adequately trained and knowledgeable in welding procedures. Determine the type of metal being welded and select the correct welding procedures and electrodes, rods or wire to provide a weld metal equivalent at least to that of the parent weld.
11. Do not damage wiring during removal operations. Reinstall the wiring so it is not damaged during installation or operation by contacting sharp corners or by rubbing against some object or hot surface.
12. Always use lift arm supports to keep lift arms raised. Keep the work tool tilted down and assure that all hydraulic pressure has been relieved for maintenance or repair work that requires the lift arms to be in the raised position.
13. Tighten connections to the correct torque. Make sure that all heat shields, clamps and guards are installed correctly to avoid excessive heat, vibration or rubbing against other parts during operation. Shields that protect against oil spray onto hot exhaust components in event of a line, tube or seal failure must be installed correctly.
14. Do not operate a machine if any rotating part is damaged or contacts another part during operation. Any high-speed rotating component that has been damaged or altered should be checked for balance before reusing. Make sure all protective devices, including guards and shields, are properly installed and functioning correctly before starting the engine or operating the machine.

## Work Tools

Only use work tools that are recommended by the manufacturer of the machine.

Make sure that all necessary guarding is in place on the host machine and on the work tool.

Wear protective glasses and protective equipment as required by conditions or as recommended in the work tool's operation manual.



## 1. Product Safety

---

Ensure that all personnel are far enough away from the work area so they will not be struck by flying objects.

Stay clear of the cutting edges, pinching surfaces or crushing surfaces of the work tool while performing any work tool maintenance, testing or adjustments.

### Asbestos Information

Equipment and replacement parts shipped from the manufacturer are asbestos free. When replacement parts are required, use only genuine manufacturer's replacement parts

Use caution when handling replacement parts from another supplier if these parts contain asbestos. Avoid inhaling dust that might be generated when handling these components or when handling asbestos debris. Inhaling this dust can be hazardous to your health.

The components that may contain asbestos fibers are lining material, and some gaskets. The asbestos that is used in these components is usually encased in a resin or sealed in some way. Normal handling is not hazardous unless airborne dust containing asbestos is generated.

If dust that may contain asbestos is present, there are several guidelines that should be followed.

1. Never use compressed air for cleaning. Avoid brushing or grinding materials that contain asbestos. Use a wet method to clean up asbestos debris. A vacuum that is equipped with the high-efficiency particulate air filter (HEPA filter) can also be used.
2. Use exhaust ventilation on permanent machining jobs.
3. Wear an approved respirator if there is no other way to control the dust.
4. Comply with applicable rules and regulations for the work place. In the USA, use Occupational Safety and Health Administration requirements. These OSHA requirements can be found in 29 CFR 1910.1001.
5. Obey environmental regulations for disposal of asbestos.
6. Stay away from areas that might have asbestos particles in the air.

### ! WARNING !

**When replacement parts are required for this product, use only genuine manufacturer's replacement parts or parts with equivalent specifications including, but not limited to physical dimensions, type, strength and material.**

**Failure to heed this warning can lead to premature failures, product damage, personal injury or death.**

---

### Machine Labels and Decals

Labels and decals placed on the machine provide safety information and operating instructions. Make sure you know the location of these labels and understand their significance.

### Product ID Number

The product ID number (PIN) is located on the left side of the firewall (Figure 1-1). Always provide the PIN when contacting the dealer about parts, service, warranty or accessories. No warranty claims will be processed unless the PIN is provided.



Figure 1-1

1-001

## Machine Label and Decal Examples

Examples of the labels and decals placed on the machine are shown on this page.

**OPERATING INSTRUCTIONS**

**OPERATOR MUST BE IN SEAT WITH LAP BAR LOWERED BEFORE MACHINE WILL OPERATE.**

**ALWAYS WEAR YOUR SEAT BELT.**

**SEE THE OPERATORS MANUAL FOR DETAILED INSTRUCTIONS.**

0304-302

**! WARNING !**

**MOUNTING AND DISMOUNTING**

**MAINTAIN 3-POINT CONTACT (2 FEET AND 1 HAND OR 1 FOOT AND 2 HANDS) WITH STEPS AND HAND HOLDS**

**WHEN LEAVING LOADER:**

1. PARK MACHINE ON LEVEL GROUND
2. LOWER WORK TOOL TO GROUND
3. STOP ENGINE AND REMOVE IGNITION KEY
4. REMOVE SEAT BELT

**PARKING BRAKE IS APPLIED AUTOMATICALLY**

0310-122

FAILURE TO FOLLOW INSTRUCTIONS OR HEED WARNINGS COULD RESULT IN INJURY OR DEATH

**! DANGER !**



**KEEP YOUR BODY INSIDE OPERATOR STATION WHILE OPERATING LOADER**

**NEVER WORK WITH YOUR ARMS, FEET OR LEGS BEYOND OPERATOR STATION**

0310-169

FAILURE TO FOLLOW INSTRUCTIONS OR HEED WARNINGS COULD RESULT IN SERIOUS INJURY OR DEATH

**! WARNING !**

**LOADER LIFT ARM BRACE MUST BE IN PLACE WHEN WORKING UNDER LIFT ARMS**

**TO ENGAGE:**

1. REMOVE WORK TOOL, PARK MACHINE ON LEVEL GROUND, LOWER LIFT ARMS.
2. RELEASE PIN THAT SECURES BRACE TO FENDER.
3. WRAP SPRING AROUND CYLINDER AND ATTACH TO OTHER SIDE OF BRACE.
4. RAISE LIFT ARMS UNTIL BRACE RESTS ON CYLINDER ROD.
5. SLOWLY LOWER LIFT ARMS UNTIL BRACE STOPS MOVEMENT.
6. SHUT OFF ENGINE AND EXIT MACHINE.

**TO DISENGAGE:**

1. REMOVE SPRING FROM CYLINDER.
2. RAISE LIFT ARMS UNTIL BRACE FALLS AWAY FROM CYLINDER ROD.
3. LOWER LIFT ARMS ALL THE WAY DOWN.
4. SHUT OFF ENGINE AND EXIT MACHINE.
5. REATTACH BRACE TO FENDER.

0304-313

FAILURE TO FOLLOW INSTRUCTIONS OR HEED WARNINGS COULD RESULT IN INJURY OR DEATH

**! DANGER !**



**KEEP OUT OF THIS AREA**

**LOADER LIFT ARM MUST BE RESTING ON LOADER STOPS WHEN WORKING UNDER RAISED LIFT ARM**

0310-139

FAILURE TO FOLLOW INSTRUCTIONS OR HEED WARNINGS COULD RESULT IN DEATH OR SERIOUS INJURY

**! WARNING !**

0304-306



**CARRY LOAD LOW. DO NOT EXCEED RATED OPERATING CAPACITY. LOAD, UNLOAD, TURN ON LEVEL GROUND.**



**TRAVEL UP AND DOWN HILL WITH HEAVIEST END OF LOADER UPHILL.**

FAILURE TO FOLLOW INSTRUCTIONS OR HEED WARNINGS COULD RESULT IN INJURY OR DEATH

**! WARNING !**

**NEVER EXCEED 10° SIDE SLOPE**



## 2. Technical Specifications

### Specifications

#### Engine

- Model: Cat 3013
- Displacement: 1.5 liter
- Gross horsepower: 31.5 hp (23.5 kW)
- Torque: 64.39 lb-ft (87.3 Nm)
- Idle rpm: 2800 (high idle); 1175 (low idle)
- Hot water temperature sender: 217°F (102.7°C)
- Average water /thermostat temperature: 190°F (87.8°C)

#### Transmission

- Model: Cat AA10VG18 tandem (Rexroth)

##### Drive pumps

- Displacement: 1.098 in<sup>3</sup>/rev (18.0 cc/rev)
- Relief pressure: 3800 psi (26,200 kPa)
- Flow: 13 gpm (11.4 lpm) @ 2800 rpm (high idle)

##### Charge pumps (2)

- Displacement: 0.33 in<sup>3</sup>/rev (5.4 cc/rev) X 2
- Relief pressure: Serial Number RSA001 through RSA01056, 450 to 500 psi (2620-2758 kPa) at high idle with warm oil, Serial Number RSA01057 and higher 340 to 380 psi at high idle with warm oil.
- Flow:
  - a. 3 gpm (11.4 lpm) combined @ 1175 rpm (low idle)
  - b. 7.8 gpm (29.5 lpm) combined @ 2800 rpm (high idle)

#### Drive Motors

- Model: Eaton/Charlynn 4000 light series
- Displacement: 19.8 in<sup>3</sup>/rev (324.5 cc/rev)
- Shuttle control: 0.046-in fitting orifices allow 1 gpm per side @ idle with 130°F (54.4°C) oil

#### Control Handles

- Model: CAT 4TH6

#### Auxiliary Pump

- Model: Rexroth
- Displacement: 0.87 in<sup>3</sup>/rev (114.3 cc/rev)
- Flow: 10 gpm (37.8 lpm) @ 2800 rpm (high idle)
- Relief pressure: 3000 psi (20,684 kPa)
- Cooling/filtering: Auxiliary oil is filtered and cooled at all times. In Auxiliary mode, the oil is filtered after the attachment to protect the machine if the attachment motor fails or contaminants are introduced from the quick couplers.

#### Loader Valve

- Model: Husko
- Relief pressure: 3000 psi (20,684 kPa)
- Pilot pressure required to move spools: 180-220 psi (1241-1517 kPa)

#### Cooler

- Burst pressure: 400 psi (2757 kPa)
- Operating pressure: 250 psi (1724 kPa)
- Bypass relief pressure: 100 psi (689 kPa)
- Average oil temperature:
  - a. 50°F (10°C) above ambient in general application
  - b. 80°F (26.6°C) above ambient in extreme application
- Hot oil sending unit: 225°F (107.2°C)

#### Critical Torque Specs

- Drive Sprocket Retainer Bolt
  - o 85 ft-lb. w/Blue Loctite
- Transmission Mounting Bolts
  - o 80 ft-lb. w/Blue Loctite
- Drive Sprocket Drive Teeth Bolts
  - o 110 ft-lb. -Dry
- Bogie Wheel Retaining Nut
  - o 80 ft-lb. -Dry



# 3. System Diagrams

## Chapter Overview

This chapter contains diagrams for the following Rubber Track Loader systems.

- Filtering and cooling system
- Auxiliary circuit system
- Drive loop system

## Filtering and Cooling System

The filtering and cooling system (Figure 3-1) contains the following major components.

- Hydraulic reservoir
- Radiator/oil cooler
- Loader valve
- Auxiliary gear pump
- Pilot control manifold

Figure 3-1

### Filtering and Cooling System

3-001

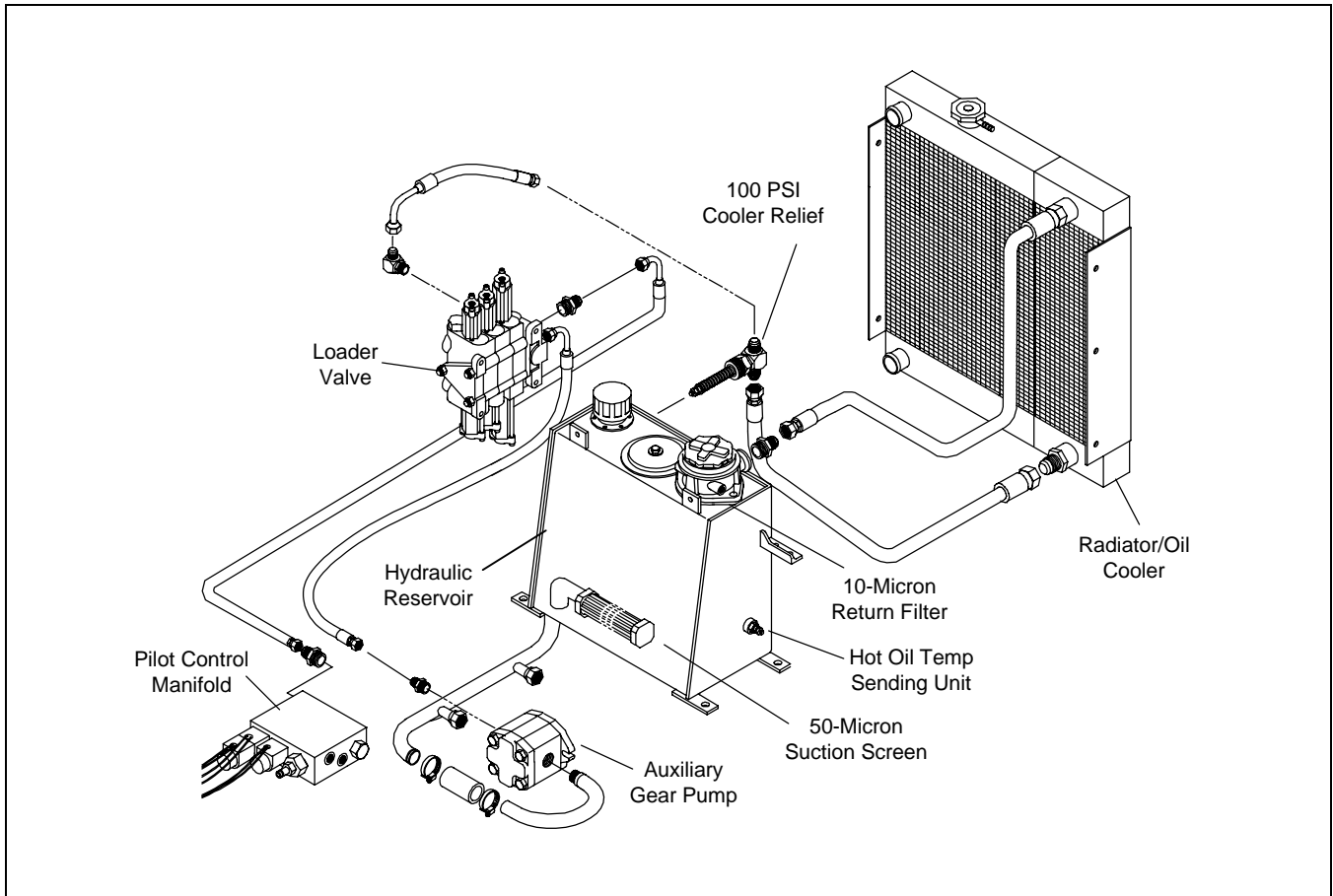

## Auxiliary Circuit System

The auxiliary circuit system (Figure 3-2) contains the following major components.

- Loader valve
- Pilot control manifold
- Auxiliary gear pump
- Loader control joystick

Figure 3-2

### Auxiliary Circuit System

3-002

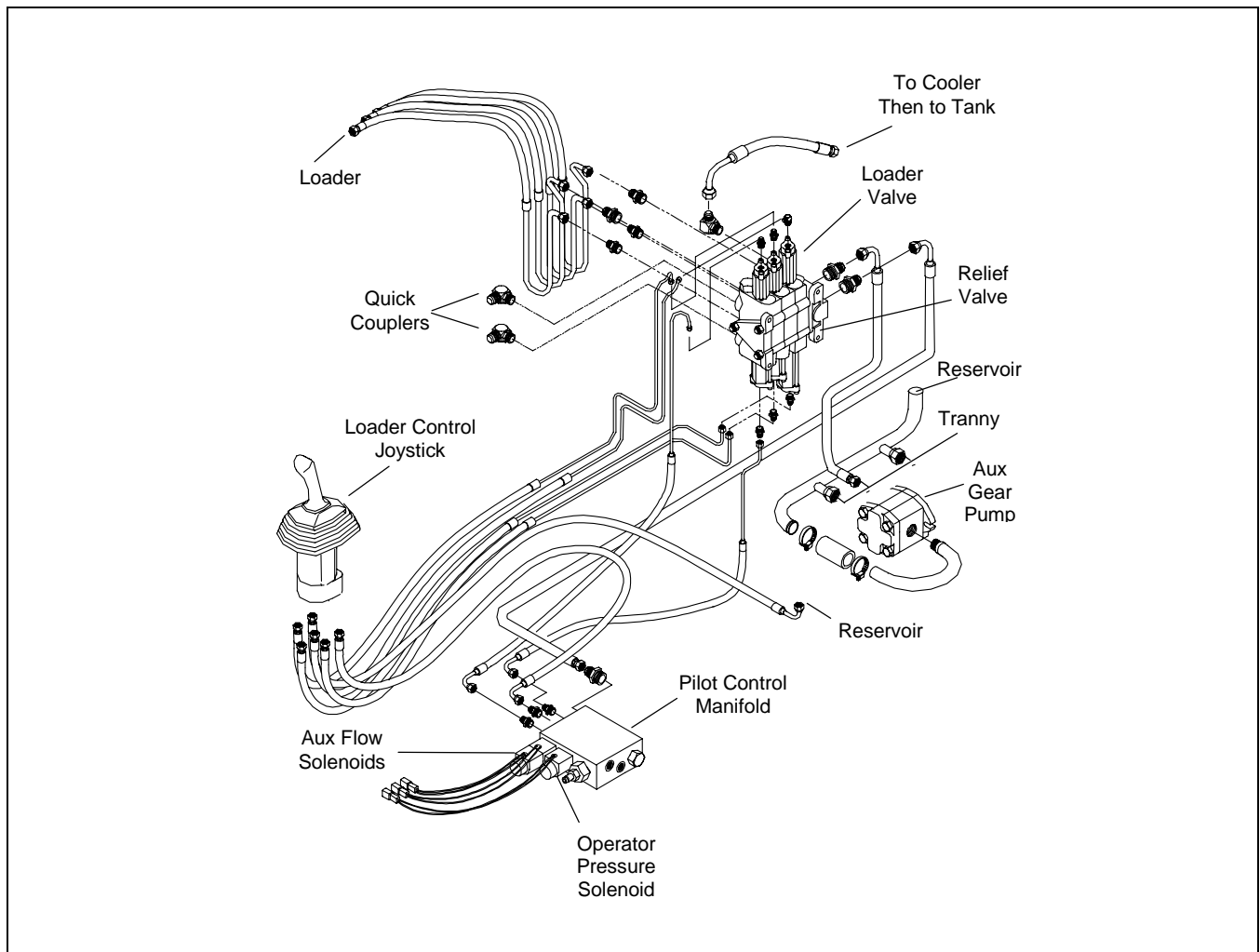

## Drive Loop System

The drive loop system (Figure 3-3) contains the following major components.

- Tandem pump
- Drive motors
- Pilot control manifold
- Brake cylinders
- Drive control joystick

Figure 3-3

### Drive Loop System

3-003

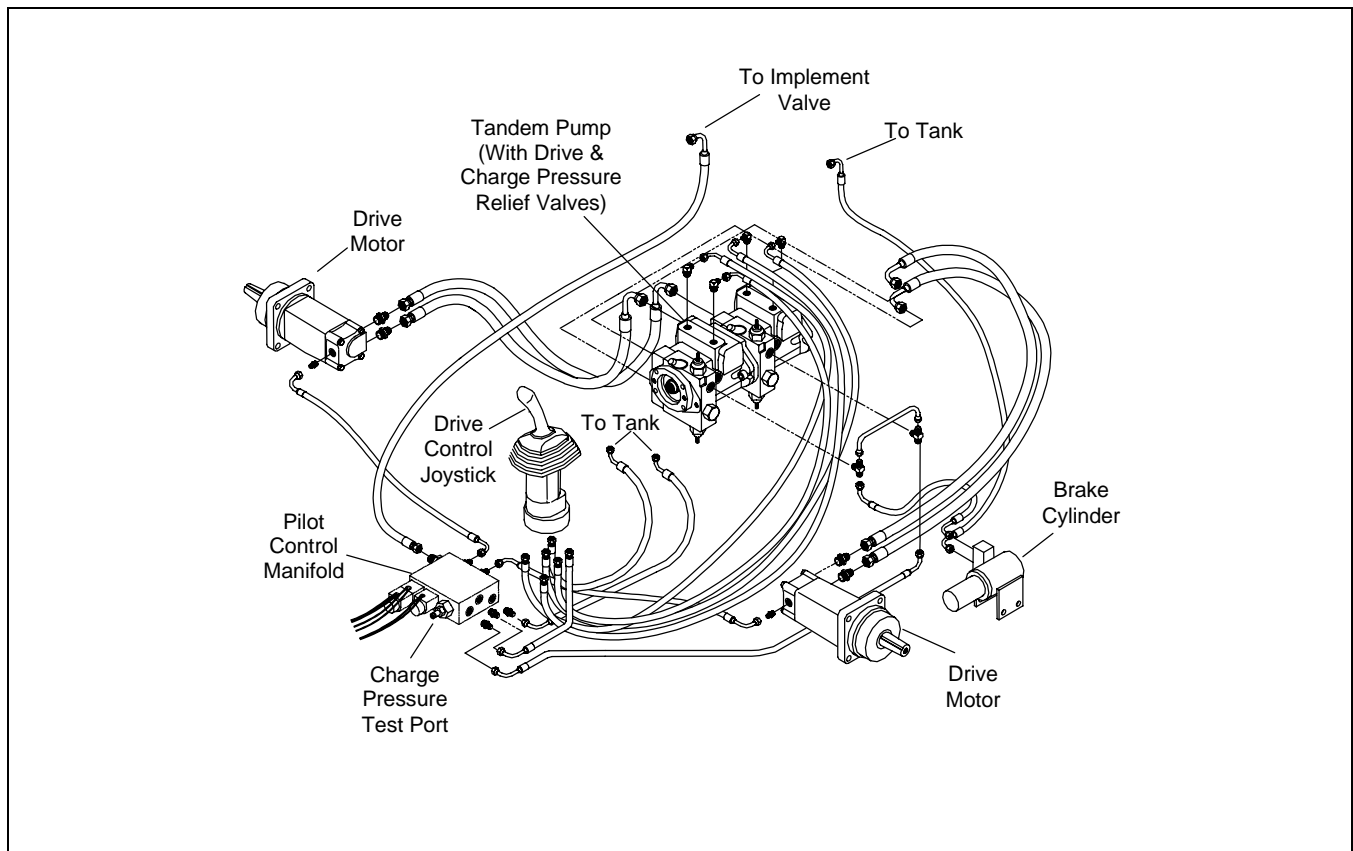





# 4. Machine Controls and Instrumentation

## Chapter Overview

This chapter contains an overview of the machine controls and instrumentation. It includes an illustration of the following controls and instrumentation components and a description of their functions.

- Machine controls
- Dash panel
- Gauge/warning light panel

## Machine Controls

There are three primary machine controls (Figure 4-1): a loader control (1), drive control (2) and throttle (3).

### Loader Control

The loader control allows the operator to raise, lower and pivot the attachment using a simple, pilot-operated joystick.

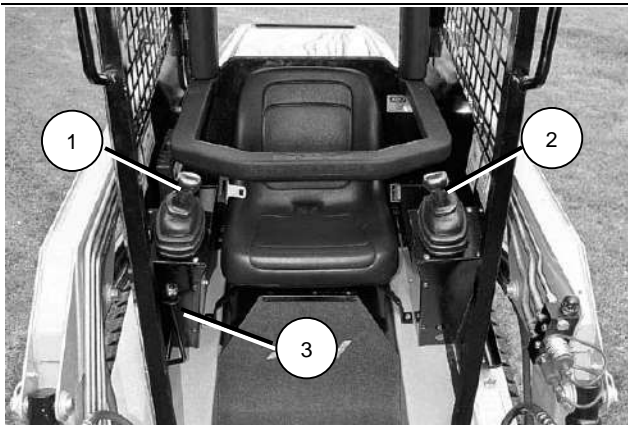

Figure 4-1

4-001

### Drive Control

The drive control allows the operator to change directions and speed using a simple, pilot-operated joystick.

### Throttle

The throttle controls engine rpm. Use lower rpm when performing work that requires precise control of the machine. Use higher rpm when faster travel speed or maximum horsepower is required. Engine rpm also directly controls the speed of the hydraulic-powered attachments, such as an auger.

## Dash Panel

The dash panel (Figure 4-2) is positioned for easy visibility in the “heads up” position inside the operator’s enclosure. The dash panel includes the following components.

- (1) Interior light
- (2) Slope indicator
- (3) Switch panel
- (4) Ignition switch
- (5) Gauge/warning light panel

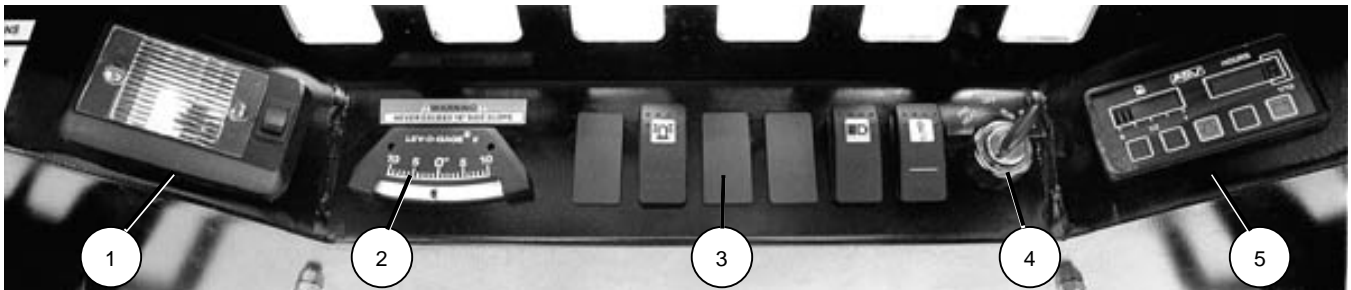

Figure 4-2

4-002

## Gauge/Warning Light Panel

The gauge/warning light panel (Figure 4-3) includes the following indicator lights.

- (1) Engine coolant temperature warning
- (2) Glow plug operation
- (3) Engine oil pressure warning
- (4) Hydraulic oil temperature warning
- (5) Battery low-voltage warning
- (6) Fuel gauge
- (7) Service hour meter

### NOTICE

If the engine coolant temperature, engine oil pressure or hydraulic oil temperature lights illuminate during normal machine operation, shut the machine down immediately. Diagnose the problem and make needed repairs before continuing to operate.

### NOTICE

If the battery low-voltage light illuminates, drive the machine to a suitable location and shut the engine off. Diagnose the problem and make needed repairs before continuing to operate. (It is normal for the low-voltage light to illuminate after starting while at low idle, the light will go out and stay out once the engine rpm reaches

The glow plug operation light illuminates only when the key switch is turned to engine pre-heat, showing normal operation.

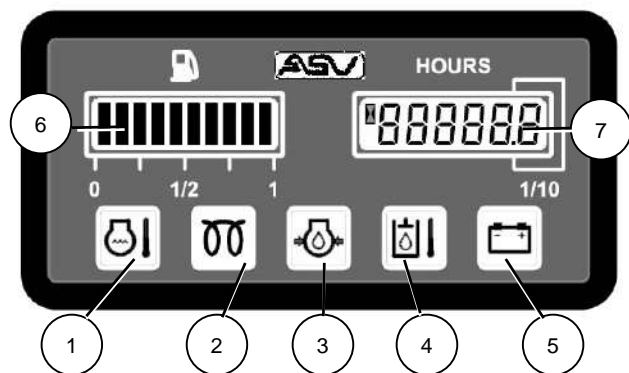

Figure 4-3

4-003

# 5. Operator Enclosure Disassembly and Assembly

## Chapter Overview

This chapter provides disassembly and assembly procedures for the operator enclosure assembly.

## Personal Safety

**! WARNING !**

Improper operation, lubrication, maintenance or repair of this product can be dangerous and could result in injury or death.

Do not operate or perform any lubrication, maintenance or repair on this product until you have read and understood the operation, lubrication, maintenance and repair information.

Before starting any disassembly or assembly procedures, refer to *Chapter 2. Product Safety – Basic Precautions* for personal safety information.

## Machine Preparation

**! WARNING !**

Accidental machine starting can cause injury or death to personnel working on the machine.

To avoid accidental machine starting, disconnect the battery cables from the battery and tape the battery clamps and remove the key.

Place a “Do Not Operate” tag prominently on the machine to inform personnel that the machine is being worked on.

Before starting any disassembly or assembly procedures, refer to *Chapter 2. Product Safety – Repair* for machine preparation information.

## Preliminary Checkout

If troubleshooting is required prior to disassembly or assembly, refer to *Chapter 15. Troubleshooting*.

## Operator Enclosure Disassembly and Assembly Procedures

Disassembly and assembly procedures are provided for the following operator enclosure components.

- Light Bar
- Ignition Switch
- Console Gauge/Warning Panel
- Lap Bar Gas Assist Spring

**Note:** Procedures are provided for only those operator enclosure components listed above. However, information for removal and installation of other operator enclosure components can be obtained from the All Surface Loader Parts List manual.

## Light Bar Removal and Installation

The tools required for light bar console removal and installation are listed in Table 5-1. Use manufacturer-recommended tools whenever possible.

Table 5-1

Required Tools
Combination Wrench

### Light Bar Removal



Figure 5-1

5-001

1. Remove the two cap screws that attach the light bar to the cab frame.

5. Operator Enclosure Disassembly and Assembly



Figure 5-2 5-002

- Carefully lower the light bar with the wire harness attached.

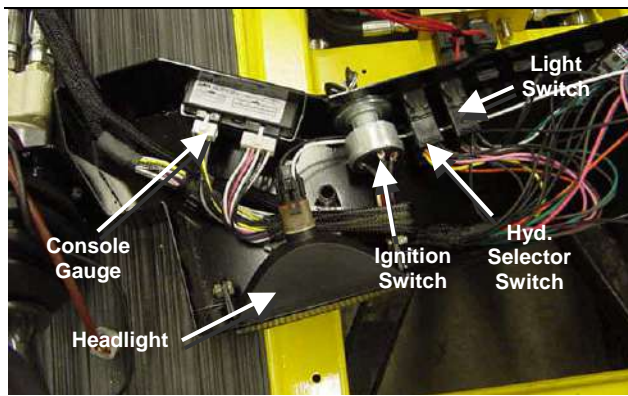

Figure 5-3 5-003

- View of light bar interior (to operator's right when seated). Interior components are now accessible for servicing.

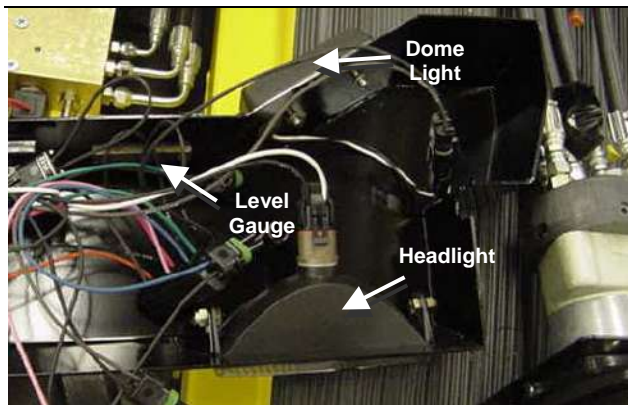

Figure 5-4 5-004

- View of light bar interior (to operator's left when seated).

Light Bar Installation



Figure 5-5 5-005

- Carefully position the light bar, without pinching the wiring harness against the cab frame.



Figure 5-6 5-006

- Secure the light bar to the cab frame with the two capscrews

Ignition Switch Removal and Installation

The tools required for ignition switch removal and installation are listed in Table 5-2. Use manufacturer-recommended tools whenever possible.

Table 5-2

Required Tools
Combination Wrench

Ignition Switch Removal

- Lower the light bar. Refer to *Chapter 5. Light Bar Removal* procedure.



5. Operator Enclosure Disassembly and Assembly

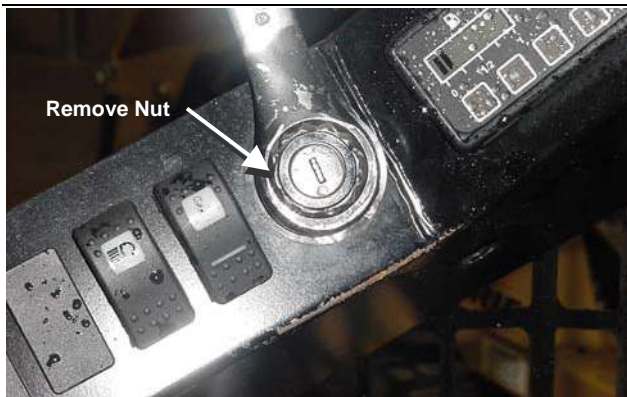

Figure 5-7 5-007

2. Remove the nut that secures the ignition switch to the dash panel.



Figure 5-8 5-008

3. Pull the ignition switch out from the rear of the dash panel.



Figure 5-9 5-009

4. Unplug the ignition switch connector.

Ignition Switch Installation



Figure 5-10 5-010

1. Insert the ignition switch from the rear of the dash panel.

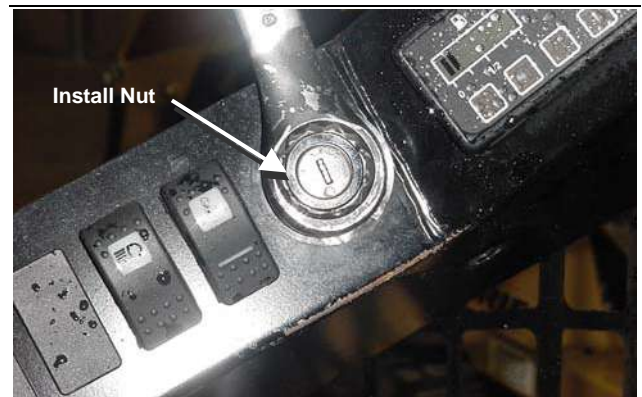

Figure 5-11 5-011

2. Install the nut that secures the ignition switch to the dash panel.



Figure 5-12 5-012

3. Plug in the ignition switch connector.

## 5. Operator Enclosure Disassembly and Assembly

4. Install the light bar. Refer to *Chapter 5. Light Bar Installation* procedure.

### Console Gauge/Warning Panel Removal and Installation

The tools required for console gauge/warning panel removal and installation are listed in Table 5-3. Use manufacturer-recommended tools whenever possible.

Table 5-3

Required Tools
Combination wrench

#### Console Gauge Removal

1. Lower the light bar. Refer to *Chapter 5. Light Bar Removal* procedure.

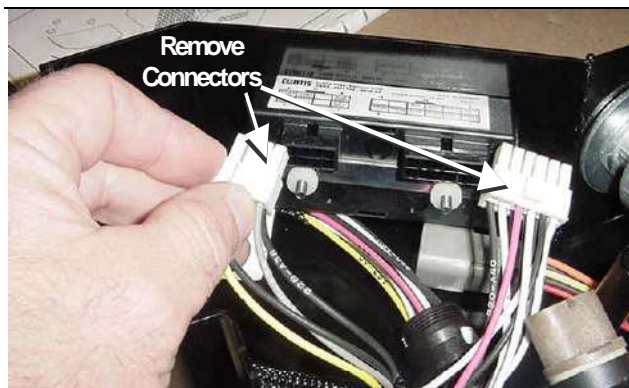

Figure 5-13

5-013

2. Remove the connectors from the console gauge.

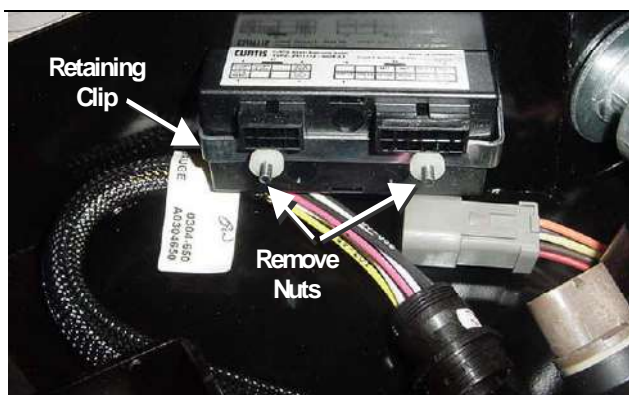

Figure 5-14

5-014

3. Remove the two nuts that secure the console gauge to the retaining clip.



Figure 5-15

5-015

4. Pull the console gauge out from the front of the dash panel.

#### Console Gauge Installation



Figure 5-16

5-016

1. Insert the console gauge from the front of the dash panel.

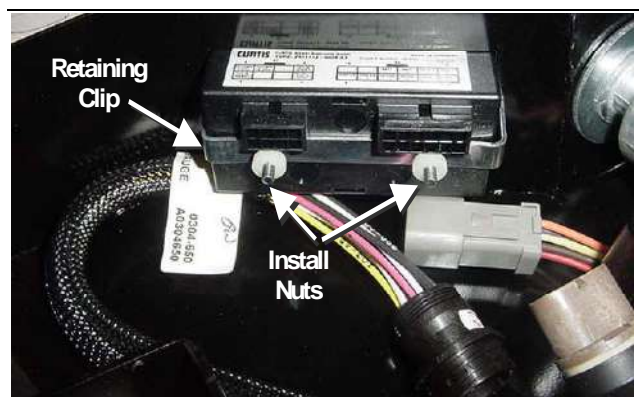

Figure 5-17

5-017

2. Install the two nuts that secure the console gauge to the retaining clip.



5. Operator Enclosure Disassembly and Assembly

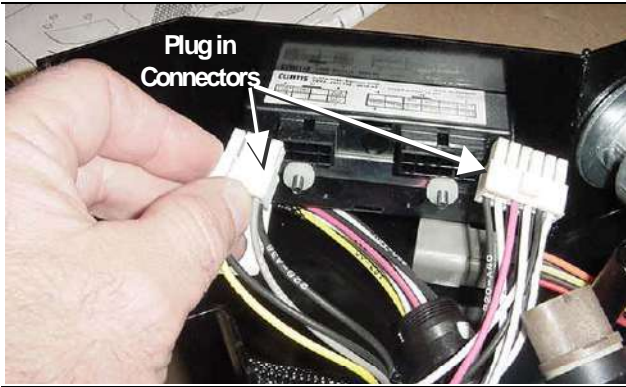

Figure 5-18

5-018

3. Plug in the console gauge connectors.
4. Install the light bar. Refer to *Chapter 5. Light Bar Installation* procedure.

## Lap Bar Gas Assist Spring Removal and Installation

The tools required for gas assist spring removal and installation are listed in Table 5-4. Use manufacturer-recommended tools whenever possible.

Table 5-4

Required Tools
Screwdriver

### Lap Bar Gas Assist Spring Removal

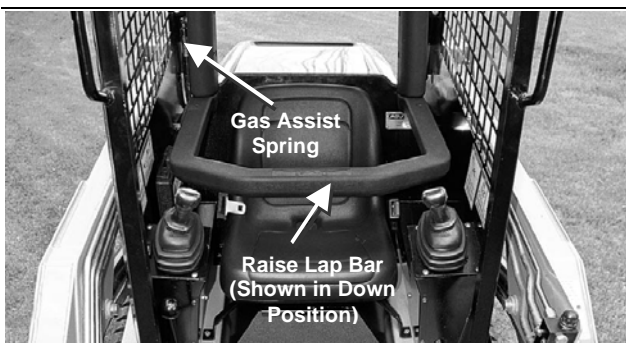

Figure 5-19

5-019

1. Put the lap bar in the UP position to relieve tension on the lap bar gas assist spring.



Figure 5-20

5-020

2. Using a small screwdriver, remove the retaining clip from each end of the gas assist spring.



Figure 5-21

5-021

3. Remove the gas assist spring by pulling both ends out from the ball joints.

### Lap Bar Gas Assist Spring Installation



Figure 5-22

5-022

1. Put the lap bar in the UP position to minimize tension on the lap bar gas assist spring during installation.



## 5. Operator Enclosure Disassembly and Assembly

---

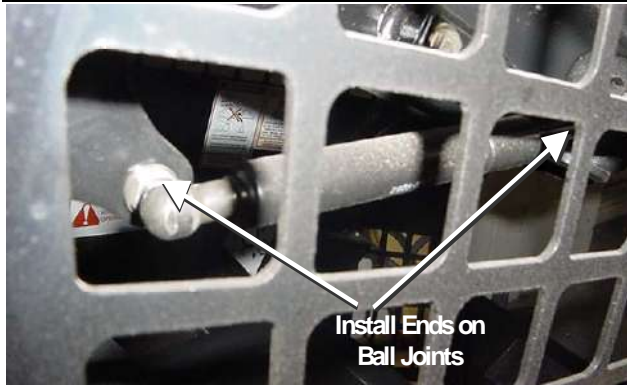

Figure 5-23

5-023

2. Install the ends of the lap bar gas assist spring onto the ball joints.

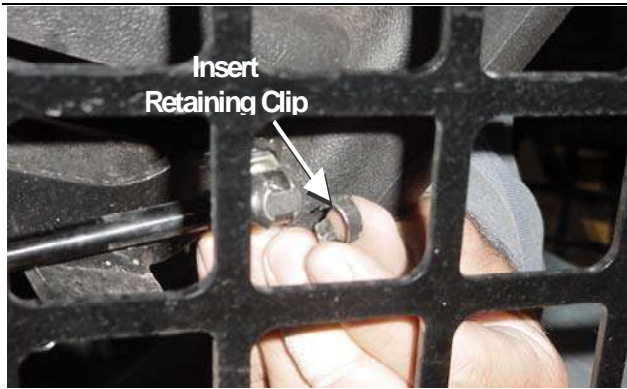

Figure 5-24

5-024

3. Slide the retaining clip on to each end of the gas assist spring.

# 6. Chassis Disassembly and Assembly

## Chapter Overview

This chapter provides disassembly and assembly procedures for the chassis assembly.

## Personal Safety

**! WARNING !**

Improper operation, lubrication, maintenance or repair of this product can be dangerous and could result in injury or death.

Do not operate or perform any lubrication, maintenance or repair on this product until you have read and understood the operation, lubrication, maintenance and repair information.

Before starting any disassembly or assembly procedures, refer to *Chapter 2. Product Safety – Basic Precautions* for personal safety information.

## Machine Preparation

**! WARNING !**

Accidental machine starting can cause injury or death to personnel working on the machine.

To avoid accidental machine starting, disconnect the battery cables from the battery and tape the battery clamps and remove the key.

Place a “Do Not Operate” tag prominently on the machine to inform personnel that the machine is being worked on.

Before starting any disassembly or assembly procedures, refer to *Chapter 2. Product Safety – Repair* for machine preparation information.

## Preliminary Checkout

If troubleshooting is required prior to disassembly or assembly, refer to *Chapter 15. Troubleshooting*.

## Chassis Disassembly and Assembly Procedures

Disassembly and assembly procedures are provided for the following chassis components.

- Seat
- Fuel Sending Unit
- Fuel Sending Unit Hose
- In-Tank Weight
- Fuel Tank

**Note:** Procedures are provided for only those chassis components listed above. However, information for removal and installation of other chassis components can be obtained from the exploded view illustration provided in the Rubber Track Loader Parts List manual.

## Seat Removal and Installation

The tools required for seat removal and installation are listed in Table 6-1. Use manufacturer-recommended tools whenever possible.

Table 6-1

Required Tools
Socket Wrench

### Seat Removal

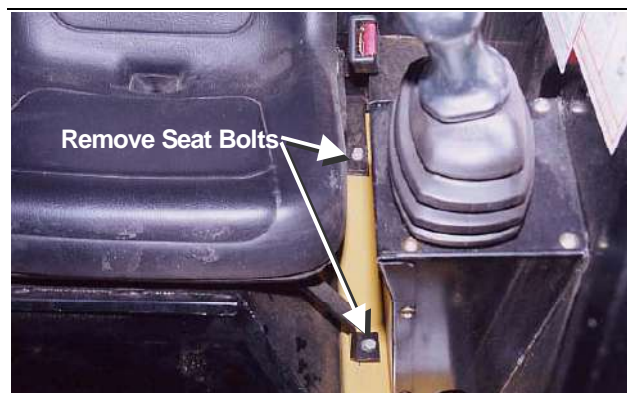

Figure 6-1

6-001

1. Remove the four bolts that fasten the seat mounts to the frame.

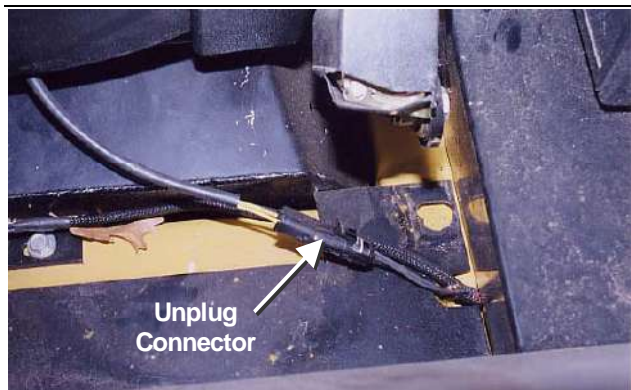

Figure 6-2 6-002

2. Tilt the seat forward and reach behind the seat to unplug the seat switch wiring harness.



Figure 6-3 6-003

3. Remove the seat. Be careful not to scratch the control panel or sides of the cab.

### Seat Installation



Figure 6-4 6-003

1. With the seat mounts attached, place the seat in the cab. Be careful not to scratch the control panel or sides of the cab.

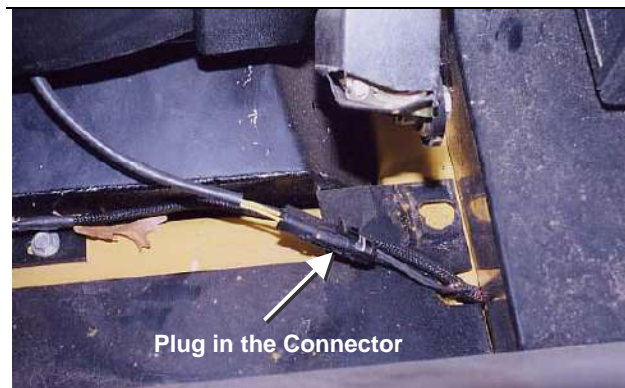

Figure 6-5 6-002

2. Tilt the seat forward and reach behind the seat to plug in the seat switch connector

**Note:** The machine will not operate unless the seat switch connector is plugged in.

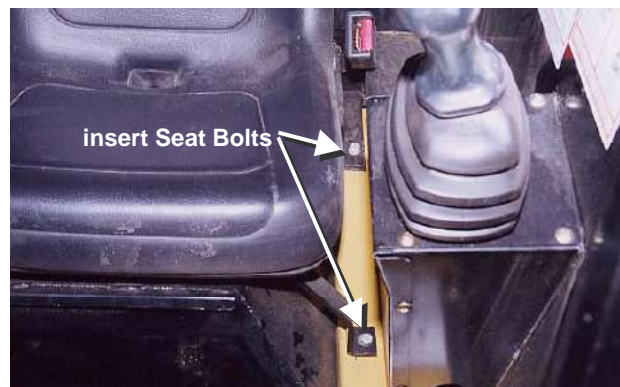

Figure 6-6 6-001

3. Position the seat so the holes in the seat mounts are aligned with the holes in the frame. Insert the four seat mount bolts and washers.

### Fuel Sending Unit Removal and Installation

The tools required for fuel sending unit removal and installation are listed in Table 6-2. Use manufacturer-recommended tools whenever possible.

Table 6-2

Required Tools
Screwdriver
Combination Wrench
Socket Wrench



### Fuel Sending Unit Removal

1. Remove the seat. Refer to *Chapter 6. Seat Removal* procedure.
2. Pump fuel from the tank until there is no fuel remaining above the sending unit.

#### NOTICE

Collect and contain liquids in a suitable container. Dispose of all liquids according to local regulations and mandates.

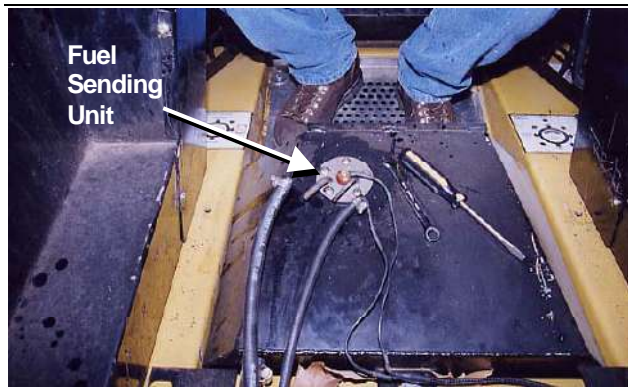

Figure 6-7

6-004

3. Remove the hoses and wires from the fuel sending unit, then remove the screws that fasten the unit to the tank. Mark the wires and hoses.

**Note:** If the fuel sending unit wires are crossed, the fuel gauge will not work. If the hoses are crossed, the engine will not run.



Figure 6-8

6-005

4. Remove the fuel sending unit. Be careful not to damage the float mechanism when pulling it through the opening in the fuel tank.



Figure 6-9

6-006

5. The fuel pickup line will also come out with the fuel sending unit.

### Fuel Sending Unit Installation



Figure 6-10

6-006

1. Insert the fuel pickup line into the fuel tank opening. The pickup line is attached to the fuel sending unit.

**Note:** The weight on the end of the fuel pickup line must rest on the bottom of the tank for proper operation.

**6. Chassis Disassembly and Assembly**



Figure 6-11

6-005

2. Insert the fuel sending unit float mechanism into the fuel tank opening. Be careful not to damage the float when pushing it through the opening.

**Note:** Make sure that the wire on the sending unit is not bent and the fuel pickup line does not interfere with the movement of the float.

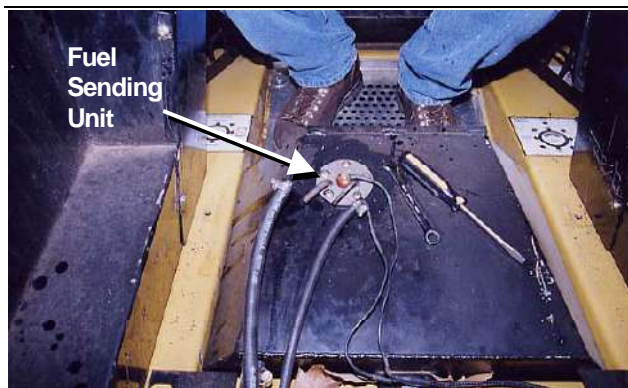

Figure 6-12

6-004

3. Connect the hoses and wires to the fuel sending unit, then install the screws that fasten the unit to the tank.

**Note:** Be careful not to cross the wires or hoses. If the fuel sending unit wires are crossed, the fuel gauge will not work. If the hoses are crossed, the engine will not run.

4. Install the seat. Refer to *Chapter 6. Seat Installation* procedure.

## Fuel Tank Removal and Installation

The tools required for fuel tank removal and installation are listed in Table 6-3. Use manufacturer-recommended tools whenever possible.

Table 6-3

Required Tools
Screwdriver
Combination Wrench
Socket Wrench

### Fuel Tank Removal

1. Remove the seat. Refer to *Chapter 6. Seat Removal* procedure.

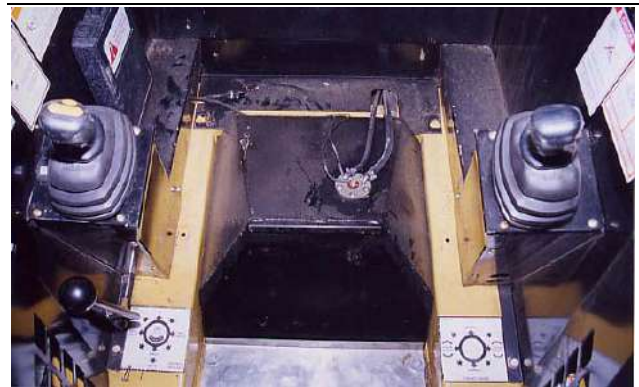

Figure 6-13

6-014

2. View of fuel tank with seat removed.
3. Pump all fuel from the fuel tank.

#### NOTICE

Collect and contain liquids in a suitable container. Dispose of all liquids according to local regulations and mandates.



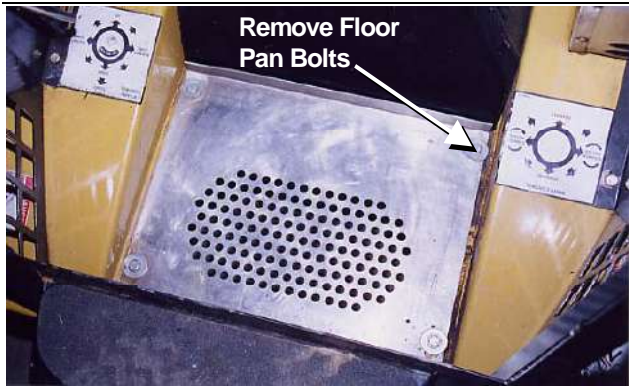

Figure 6-14

6-007

4. Remove the four bolts that hold the floor pan to the frame.

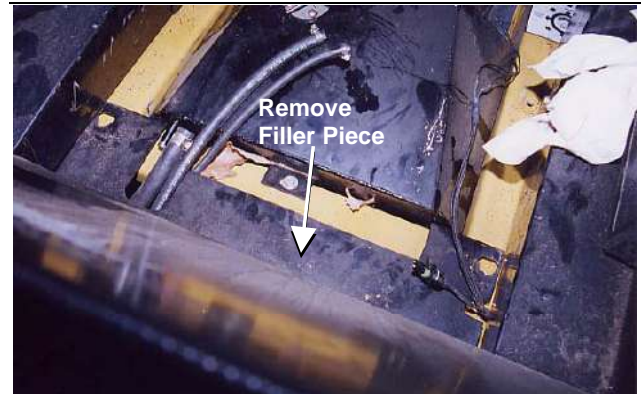

Figure 6-17

6-009

7. Remove the steel filler piece behind the fuel tank.



Figure 6-15

6-008

5. Remove the floor pan.

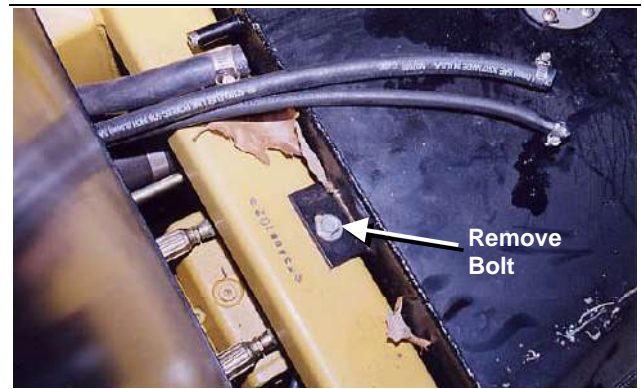

Figure 6-18

6-010

8. Remove the bolt that fastens the fuel tank to the frame.

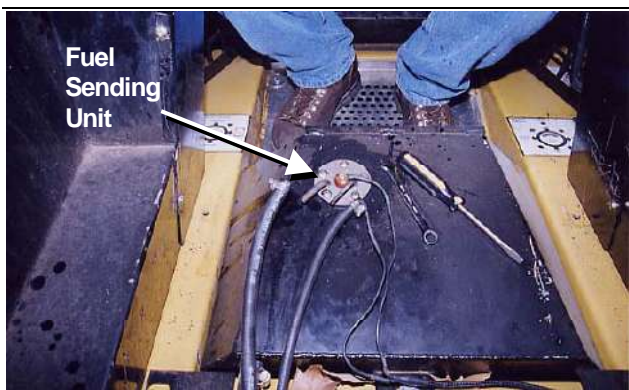

Figure 6-16

6-004

6. Remove the hoses and wires from the fuel sending unit.



Figure 6-19

6-011

9. Disconnect the rubber vent hose from the fuel tank.

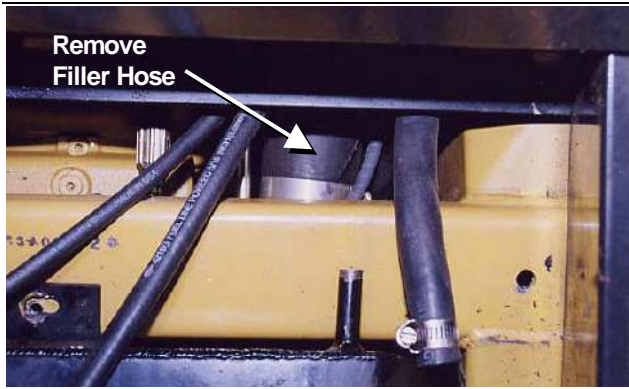

Figure 6-20 6-012

10. Remove the rubber filler hose from the back end or the tank.

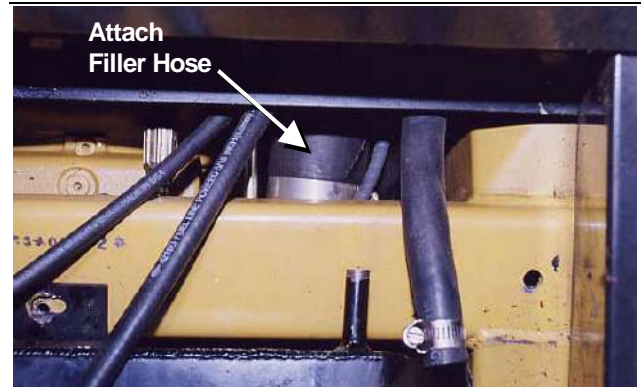

Figure 6-23 6-012

2. Attach the filler hose to the rear of the tank.



Figure 6-21 6-013

11. Remove the tank carefully from the machine.

### Fuel Tank Installation



Figure 6-22 6-013

1. Place the fuel tank in the machine in approximately its normal position.



Figure 6-24 6-011

3. Connect the vent hose to the fuel tank.

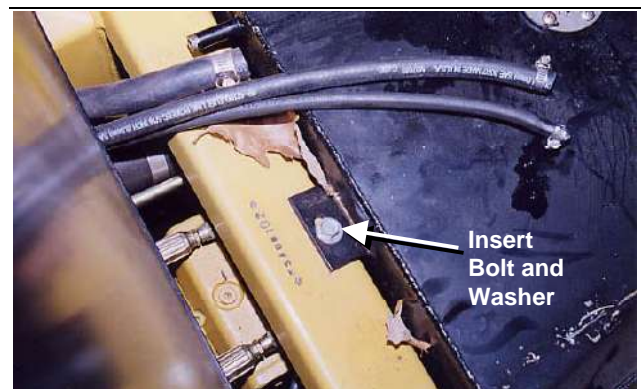

Figure 6-25 6-010

4. Insert the bolt and washer that connect the fuel tank to the frame.



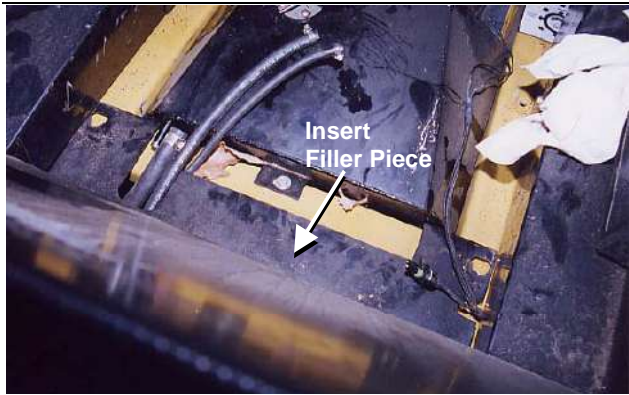

Figure 6-26

6-009

5. Insert the steel filler piece behind the fuel tank.

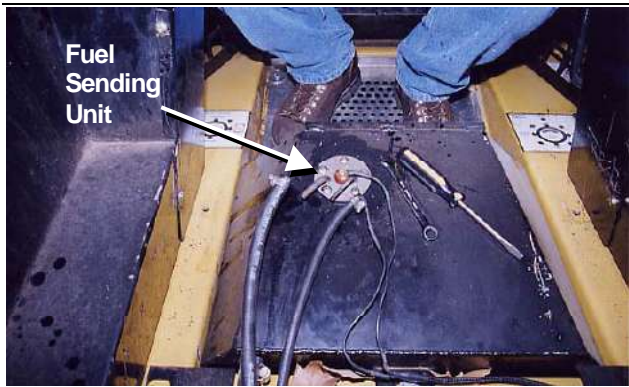

Figure 6-27

6-004

6. Attach the hoses and wiring to the fuel sending unit.



Figure 6-28

6-008

7. Replace the floor pan.



Figure 6-29

6-007

8. Install the four floor pan bolts and washers.
9. Install the seat. Refer to *Chapter 6. Seat Installation* procedure.





# 7. Radiator/Oil Cooler Disassembly and Assembly

## Chapter Overview

This chapter provides disassembly and assembly procedures for the radiator/oil cooler assembly. Adjustment procedures are also included for selected radiator/oil cooler components.

## Personal Safety

### ! WARNING !

Improper operation, lubrication, maintenance or repair of this product can be dangerous and could result in injury or death.

Do not operate or perform any lubrication, maintenance or repair on this product until you have read and understood the operation, lubrication, maintenance and repair information.

Before starting any disassembly or assembly procedures, refer to *Chapter 2. Product Safety – Basic Precautions* for personal safety information.

## Machine Preparation

### ! WARNING !

Accidental machine starting can cause injury or death to personnel working on the machine.

To avoid accidental machine starting, disconnect the battery cables from the battery and tape the battery clamps and remove the key.

Place a “Do Not Operate” tag prominently on the machine to inform personnel that the machine is being worked on.

Before starting any disassembly or assembly procedures, refer to *Chapter 2. Product Safety – Repair* for machine preparation information.

## Preliminary Checkout

If troubleshooting is required prior to disassembly or assembly, refer to *Chapter 15. Troubleshooting*.

## Radiator/Oil Cooler Disassembly and Assembly Procedures

Disassembly and assembly procedures are provided for the following radiator/oil cooler components.

- Fan Guard
- Fan Shroud
- Fan
- Multi-Wing Fan
- Radiator/Cooler

**Note:** Procedures are provided for only those radiator/oil cooler components listed above. However, information for removal and installation of other radiator/oil cooler components can be obtained from the Rubber Track Loader Parts List manual.

**Note:** Refer to Figure 3-1 for an overview of the filtering and cooling system.

## Fan Guard Removal and Installation

The tools required for fan guard removal and installation are listed in Table 7-1. Use manufacturer-recommended tools whenever possible.

Table 7-1

Required Tools
Combination Wrench

### Fan Guard Removal

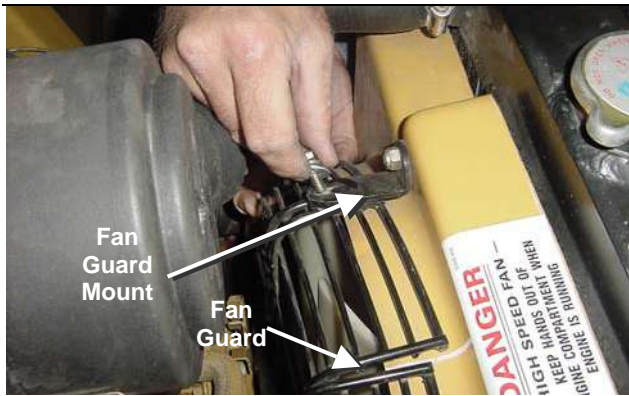

Figure 7-1 7-001

1. Remove the capscrews that secure the fan guard to the fan guard mounts.
2. Remove the fan guard from the engine compartment.

### Fan Guard Installation

1. Position the fan guard over the fan and against the fan shroud.

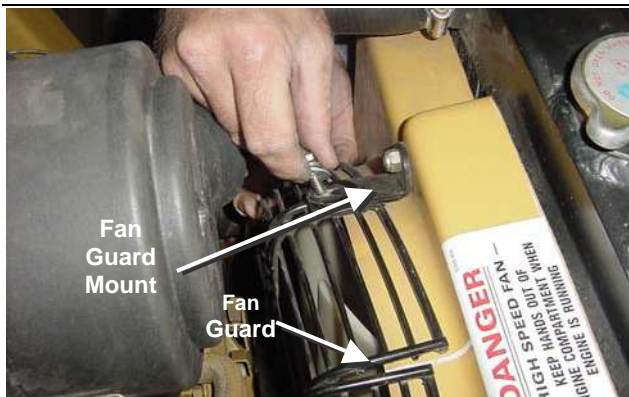

Figure 7-2 7-001

2. Install the capscrews that secure the fan guard to the fan guard mounts.

### Fan and Fan Shroud Removal and Installation

The tools required for fan and fan shroud removal and installation are listed in Table 7-2. Use manufacturer-recommended tools whenever possible.

Table 7-2

Required Tools
Combination Wrench
Socket Wrench

### Fan and Fan Shroud Removal

**! WARNING !**

**Hot oil can cause personal injury. Make sure the oil is cool before removing any components or lines.**

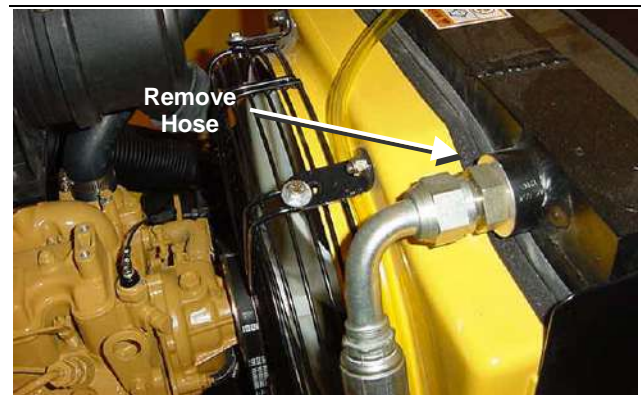

Figure 7-3 7-002

1. Remove the upper hose from the oil cooler section. Cap the hose and fitting.
2. Remove the fan guard. Refer to *Chapter 7. Fan Guard Removal*.

**7. Radiator/Oil Cooler Disassembly and Assembly**

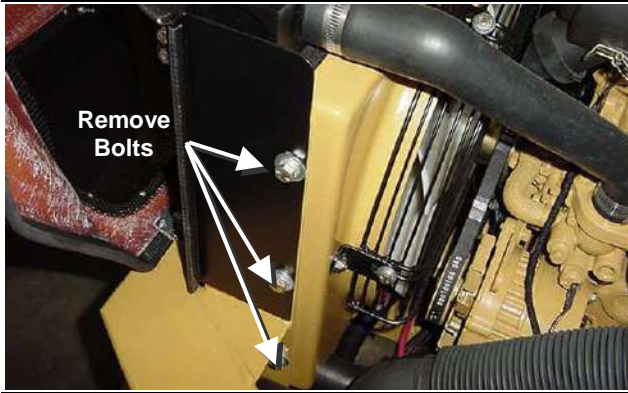

Figure 7-4

7-003

3. Remove the three bolts from each side of the fan shroud that secure the shroud to the radiator/cooler.



Figure 7-7

7-006

6. Remove the shroud from the engine compartment.



Figure 7-5

7-004

4. With the shroud pulled back, reach between the radiator/cooler and the fan and remove the four bolts that secure the fan to the engine.

**Fan and Fan Shroud Installation**

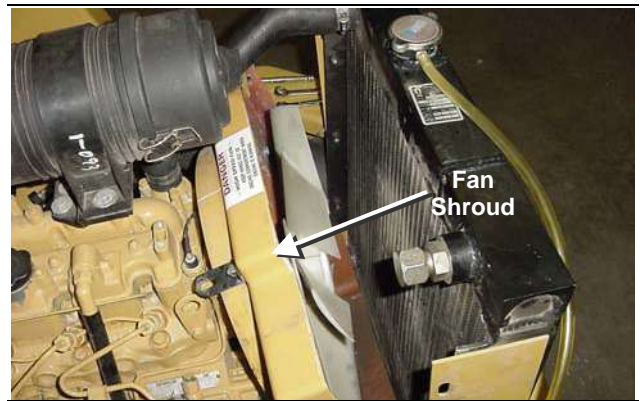

Figure 7-8

7-007

1. Place the fan shroud in the engine compartment.



Figure 7-6

7-005

5. Remove the fan from the engine compartment.

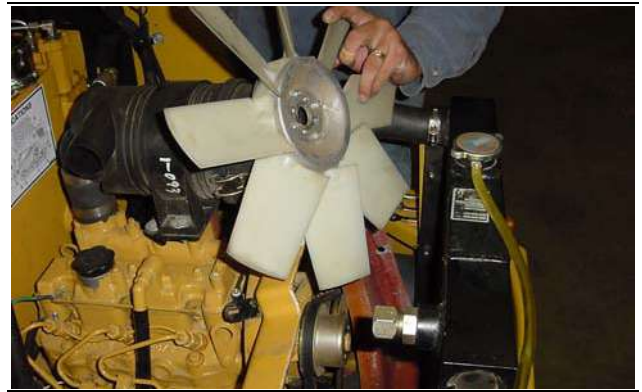

Figure 7-9

7-005

2. Place the fan in the engine compartment.





Figure 7-10

7-004

3. Holding the fan in position between the radiator/cooler and the fan shroud, install the four bolts that secure the fan to the fan drive motor.

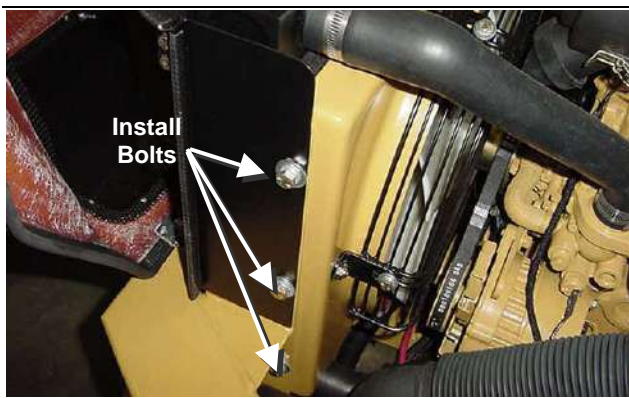

Figure 7-11

7-003

4. Pull the shroud over the fan and install the three bolts on each side of the fan shroud that secure the shroud to the radiator/cooler.
5. Install the fan guard. Refer to *Chapter 7. Fan Guard Installation*.



Figure 7-12

7-002

6. Install the upper hose on the oil cooler section.

## Radiator/Cooler Removal and Installation

The tools required for radiator/cooler removal and installation are listed in Table 7-3. Use manufacturer-recommended tools whenever possible.

Table 7-3

Required Tools
Combination Wrench
Socket Wrench
Screwdriver

### Radiator/Cooler Removal

#### ! WARNING !

Hot oil can cause personal injury. Make sure the oil is cool before removing any components or lines.

Remove the oil filler cap only when the engine is stopped and the filler cap is cool enough to touch with your bare hand.

#### ! WARNING !

Personal injury can result from hot coolant, steam and alkali.

At operating temperature, engine coolant is hot and under pressure. The radiator and all lines to the heaters and the engine contain hot coolant and steam. Contact can cause severe burns.

Remove the filler cap slowly to relieve pressure only when the engine is stopped and the radiator cap is cool enough to touch with your bare hand.

Do not attempt to tighten the hose connections when the coolant is hot. The hose can come off and cause burns.

Cooling system conditioner contains alkali. Avoid contact with skin and eyes.

#### NOTICE

Collect and contain liquids in a suitable container. Dispose of all liquids according to local regulations and mandates.

1. Remove fan and shroud. Refer to *Chapter 7*.
2. Drain the hydraulic fluid. Refer to *Chapter 16. Hydraulic Fluid and Filter Change*.

## 7. Radiator/Oil Cooler Disassembly and Assembly



Figure 7-13

7-008

- Remove the bolts from the lower engine compartment screen.

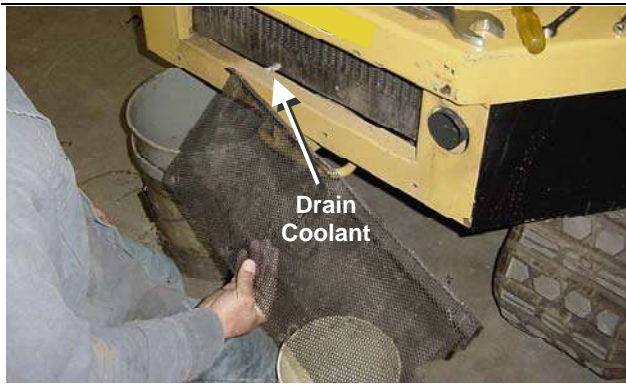

Figure 7-14

7-009

- Remove the lower engine compartment screen and drain the coolant using the petcock on the bottom of the radiator.



Figure 7-15

7-010

- Remove the lower hose from the oil cooler section. Cap the hose and fitting.



Figure 7-16

7-002

- Remove the upper hose from the oil cooler section. Cap the hose and fitting.

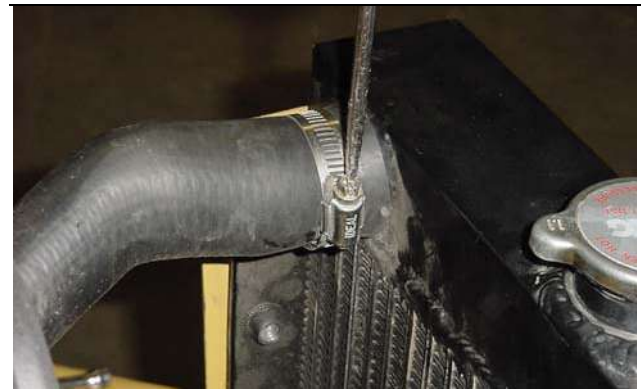

Figure 7-17

7-011

- Remove the upper hose from the radiator section. Cap the hose and fitting.



Figure 7-18

7-012

- Remove the lower hose from the radiator section. Cap the hose and fitting.



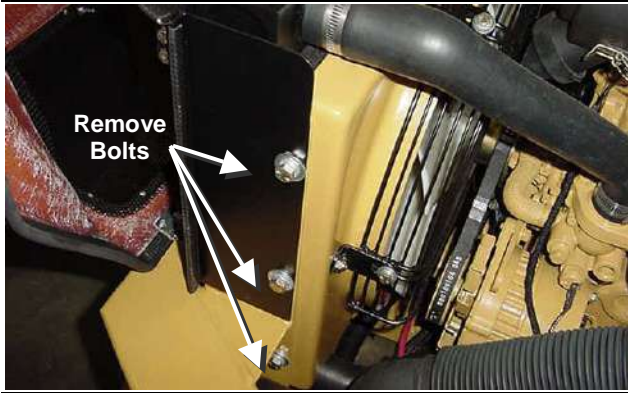

Figure 7-19 7-003

9. Remove the three mounting bolts on each side of the radiator/cooler.

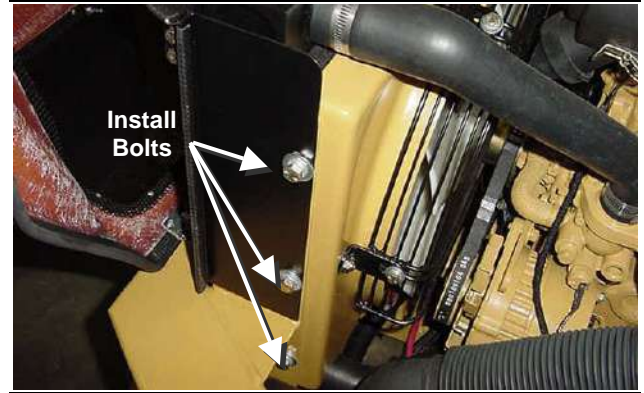

Figure 7-22 7-003

2. With the radiator/cooler in position, install the three mounting bolts on each side of the radiator/cooler.



Figure 7-20 7-013

10. Remove the radiator/cooler from the engine compartment.



Figure 7-23 7-012

3. Remove the hose and fitting caps and install the lower hose on the radiator section.

### Radiator/Cooler Installation



Figure 7-21 7-013

1. Position the radiator/cooler in the engine compartment.

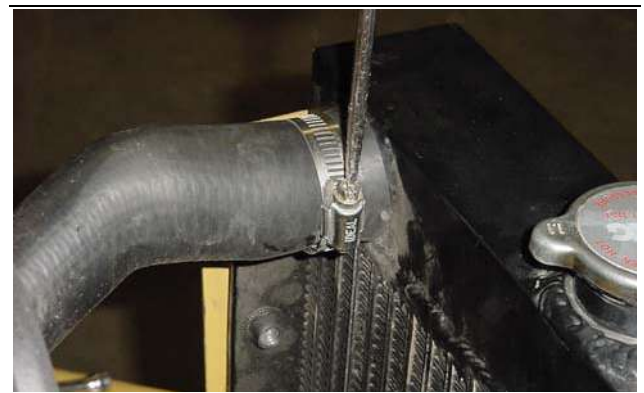

Figure 7-24 7-011

4. Remove the hose and fitting caps and install the upper hose on the radiator section.

**7. Radiator/Oil Cooler Disassembly and Assembly**



Figure 7-25 7-002

5. Remove the hose and fitting caps and install the upper hose on the oil cooler section.



Figure 7-26 7-010

6. Remove the hose and fitting caps and install the lower hose on the oil cooler section.



Figure 7-27 7-008

7. Position the lower engine compartment screen and secure with the mounting bolts.

8. Fill the radiator with coolant and the hydraulic reservoir with oil.

**Radiator/Oil Cooler Adjustment Procedures**

Adjustment procedures are provided for the following radiator/oil cooler components.

- Fan Shroud
- Fan Guard

**Fan Shroud Adjustment**

The tools required for fan shroud adjustment are listed in Table 7-4. Use manufacturer-recommended tools whenever possible.

Table 7-4

Tool Name
Combination Wrench

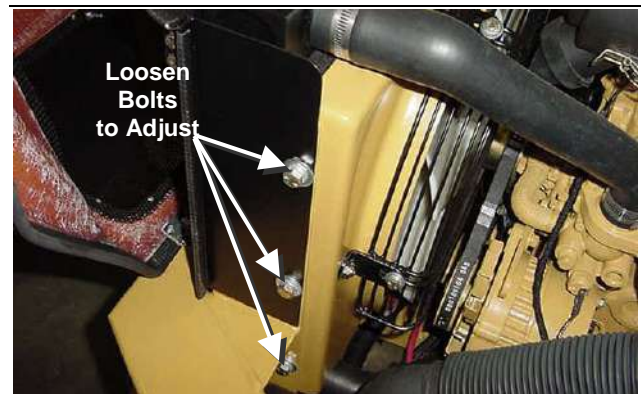

Figure 7-28 7-003

1. The fan shroud can adjusted upward or downward. To adjust, loosen the bolts on each side of the shroud and move the shroud in the desired direction. Tighten the bolts when finished.



### Fan Guard Adjustment

The tools required for fan guard adjustment are listed in Table 7-5. Use manufacturer-recommended tools whenever possible.

Table 7-5

Tool Name
Combination Wrench

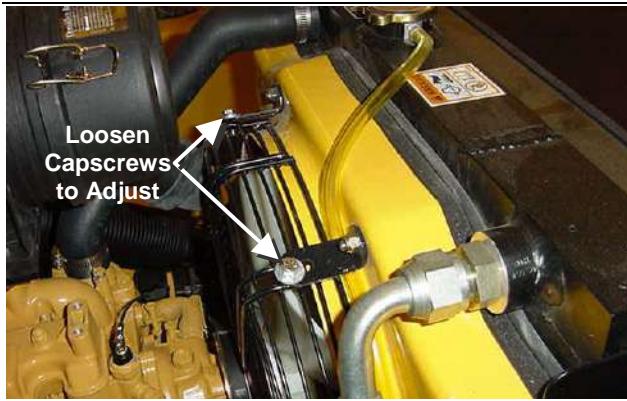

Figure 7-29

7-002

1. The fan guard can adjusted forward or rearward. To adjust, loosen the capscrews that fasten the fan guard to the fan guard mounts. Tighten the capscrews when finished.

# 8. Hydraulic Reservoir Disassembly and Assembly

## Chapter Overview

This chapter provides disassembly and assembly procedures for the hydraulic reservoir assembly. Cleaning procedures are also included for the hydraulic reservoir.

## Personal Safety

**! WARNING !**

**Improper operation, lubrication, maintenance or repair of this product can be dangerous and could result in injury or death.**

**Do not operate or perform any lubrication, maintenance or repair on this product until you have read and understood the operation, lubrication, maintenance and repair information.**

Before starting any disassembly or assembly procedures, refer to *Chapter 2. Product Safety – Basic Precautions* for personal safety information.

## Machine Preparation

**! WARNING !**

**Accidental machine starting can cause injury or death to personnel working on the machine.**

**To avoid accidental machine starting, disconnect the battery cables from the battery and tape the battery clamps and remove the key.**

**Place a “Do Not Operate” tag prominently on the machine to inform personnel that the machine is being worked on.**

Before starting any disassembly or assembly procedures, refer to *Chapter 2. Product Safety – Repair* for machine preparation information.

## Preliminary Checkout

If troubleshooting is required prior to disassembly or assembly, refer to *Chapter 15. Troubleshooting*.

## Hydraulic Reservoir Disassembly and Assembly Procedures

Disassembly and assembly procedures are provided for the following hydraulic reservoir components.

- Filter Element
- Filter Assembly
- Filler Cap Assembly
- Access Cover Assembly
- Reservoir Gauge
- Suction Screen

**Note:** Procedures are provided for only those hydraulic reservoir components listed above. However, information for removal and installation of other hydraulic reservoir components can be obtained from the Rubber Track Loader Parts List manual.

**Note:** Refer to Figure 3-1 for an overview of the filtering and cooling system.

## Filter Element Removal and Installation

Refer to *Chapter 16. Maintenance – Hydraulic Fluid and Filter* for removal and installation of the filter.

## Filter Assembly Removal and Installation

The tools required for filter assembly removal and installation are listed in Table 8-1. Use manufacturer-recommended tools whenever possible.

Table 8-1

Required Tools
Combination Wrench

## Filter Assembly Removal

### ! WARNING !

Hot oil can cause personal injury. Make sure the oil is cool before removing any components or lines.

Remove the oil filler cap only when the engine is stopped and the filler cap is cool enough to touch with your bare hand.

**Note:** During disassembly, cap all hoses and fittings to prevent fluid loss and contamination of the system fluids.



Figure 8-1 8-001

1. Remove the hose from the left side of the filter assembly. Cap hose and fitting.



Figure 8-2 8-002

2. Remove the hose from the front of the filter assembly. Cap hose and fitting.

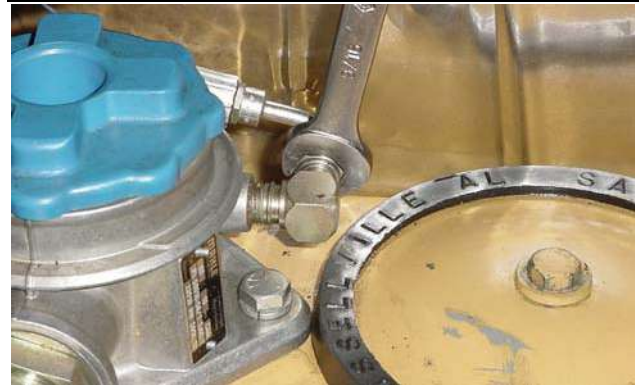

Figure 8-3 8-003

3. Remove the hose from the right side of the filter assembly. Cap hose and fitting.



Figure 8-4 8-004

4. Remove the two bolts that secure the filter assembly to the reservoir.



Figure 8-5 8-005

5. Pull the filter assembly out of the reservoir.



**8. Hydraulic Reservoir Disassembly and Assembly**



Figure 8-6

8-006

6. Remove the filter assembly gasket from the reservoir.

**Filter Assembly Installation**



Figure 8-7

8-006

1. Place the filter assembly gasket in position on top of the reservoir. Replace if damaged.

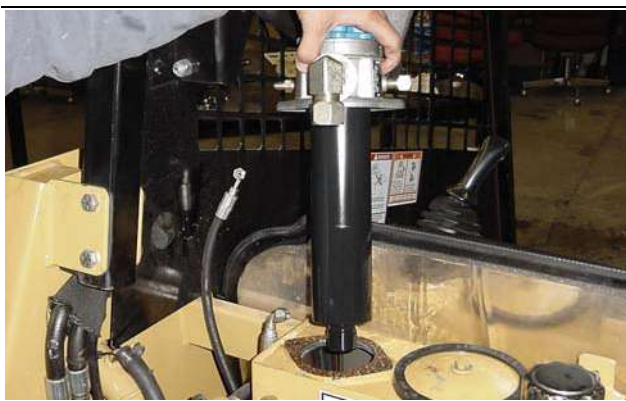

Figure 8-8

8-005

2. Position the filter assembly on the gasket with the mounting holes aligned.



Figure 8-9

8-004

3. Install the two bolts that secure the filter assembly to the reservoir.

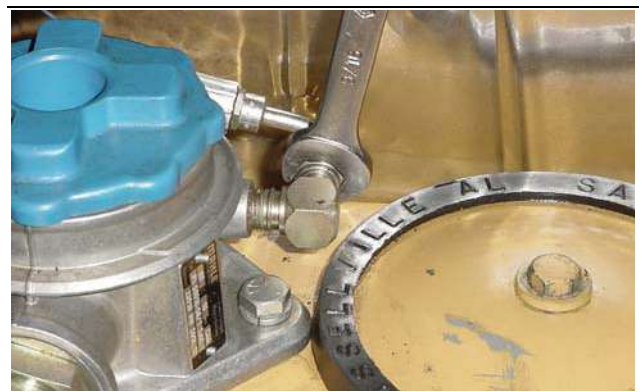

Figure 8-10

8-003

4. Install the hose on the right side of the filter assembly.



Figure 8-11

8-002

5. Install the hose on the front side of the filter assembly.

### 8. Hydraulic Reservoir Disassembly and Assembly



Figure 8-12

8-001

6. Install the hose on the left side of the filter assembly.



Figure 8-13

8-007

1. Pull the filler cap off and remove the six screws from around the base of the filler cap flange.

## Filler Cap Assembly Removal and Installation

The tools required for filler cap assembly removal and installation are listed in Table 8-2. Use manufacturer-recommended tools whenever possible.

Table 8-2

Required Tools
Screwdriver



Figure 8-14

8-008

2. Remove the filler cap flange.

### Filler Cap Assembly Removal

#### ! WARNING !

Hot oil can cause personal injury. Make sure the oil is cool before removing any components or lines.

Remove the oil filler cap only when the engine is stopped and the filler cap is cool enough to touch with your bare hand.



Figure 8-15

8-009

3. Pull the filler cap screen out of the reservoir.



## 8. Hydraulic Reservoir Disassembly and Assembly



Figure 8-16

8-010

4. Remove the filler cap gasket from the reservoir.

### Filler Cap Assembly Installation



Figure 8-17

8-011

1. Place the filler cap assembly gasket in position on top of the reservoir.



Figure 8-18

8-009

2. Insert the filler cap screen in the reservoir.



Figure 8-19

8-008

3. Place the filler cap flange on the gasket with the mounting holes aligned.



Figure 8-20

8-007

4. Insert the six screws in the base of the filler cap flange and replace the cap. Put thread sealant on the six screws before installing.

### Access Cover Removal and Installation

The tools required for access cover removal and installation are listed in Table 8-3. Use manufacturer-recommended tools whenever possible.

Table 8-3

Required Tools
Combination Wrench

### Access Cover Assembly Removal

**! WARNING !**

Hot oil can cause personal injury. Make sure the oil is cool before removing any components or lines.

Remove the oil filler cap only when the engine is stopped and the filler cap is cool enough to touch with your bare hand.



Figure 8-21

8-012

1. Slightly loosen the access cover bolt to separate the upper cap from the oval-shaped clamping disk on the underside of the assembly. This will allow the assembly to be removed. Do not remove the bolt entirely or the oval-shaped clamp will fall into the reservoir.



Figure 8-22

8-013

2. Remove the access cover assembly from the reservoir.

### Access Cover Assembly Installation



Figure 8-23

8-013

1. Insert the access cover assembly with the clamping disk extending completely through the opening in the top of the reservoir and into the tank.



Figure 8-24

8-012

2. Tighten the access cover bolt.



## Reservoir Gauge Removal and Installation

The tools required for reservoir gauge removal and installation are listed in Table 8-4. Use manufacturer-recommended tools whenever possible.

Table 8-4

Required Tools
Combination Wrench

### Reservoir Gauge Removal

**! WARNING !**

Hot oil can cause personal injury. Make sure the oil is cool before removing any components or lines.

Remove the oil filler cap only when the engine is stopped and the filler cap is cool enough to touch with your bare hand.

**NOTICE**

Collect and contain liquids in a suitable container. Dispose of all liquids according to local regulations and mandates.

**Note:** During disassembly, cap all hoses and fittings to prevent fluid loss and contamination of the system fluids.

1. Drain the hydraulic fluid. Refer to *Chapter 16. Hydraulic Fluid and Filter Change.*
2. Remove the filter assembly. Refer to *Chapter 8. Filter Assembly Removal.*



Figure 8-25

8-016

3. View of hydraulic reservoir with filter assembly removed.



Figure 8-26

8-017

4. Reach inside the reservoir and remove the two nuts that fasten the reservoir gauge to the reservoir.

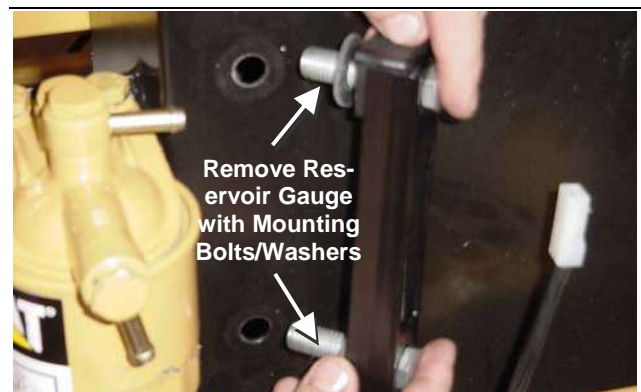

Figure 8-27

8-018

5. Pull the reservoir gauge and the two mounting bolts/washers off the reservoir. DO NOT misplace the rubber washers or the reservoir will leak.







Figure 8-31

8-015

4. Reach inside the reservoir and unscrew the suction screen. Remove the suction screen from the reservoir.

### Suction Screen Installation



Figure 8-32

8-015

1. Insert the suction screen in the reservoir through the access cover opening.
2. Reach inside the reservoir and screw the suction screen into the bottom of the reservoir.
3. Install the access cover assembly. Refer to *Chapter 8. Access Cover Assembly Installation*.
4. Add manufacturer-approved hydraulic fluid.

## Hydraulic Reservoir Cleaning Procedures

Cleaning procedures are provided for the following hydraulic reservoir components.

- Hydraulic Reservoir

### Hydraulic Reservoir Cleaning

The tools required for hydraulic reservoir cleaning are listed in Table 8-6. Use manufacturer-recommended tools whenever possible.

Table 8-6

Tool Name
Combination Wrench

### **! WARNING !**

**Hot oil can cause personal injury. Make sure the oil is cool before removing any components or lines.**

**Remove the oil filler cap only when the engine is stopped and the filler cap is cool enough to touch with your bare hand.**

### **NOTICE**

Collect and contain liquids in a suitable container. Dispose of all liquids according to local regulations and mandates.

1. Drain the hydraulic fluid. Refer to *Chapter 16. Hydraulic Fluid and Filter Change*.
2. Remove the access cover assembly. Refer to *Chapter 8. Access Cover Assembly Removal*.
3. Thoroughly wipe out the interior of the hydraulic reservoir with a magnet and a clean rag.
4. Install the access cover assembly. Refer to *Chapter 8. Access Cover Assembly Installation*.
5. Add manufacturer-approved hydraulic fluid.



# 9. Loader/Transmission Controls Disassembly and Assembly

## Chapter Overview

This chapter provides disassembly and assembly procedures for the loader/transmission controls assembly.

## Personal Safety

### ! WARNING !

Improper operation, lubrication, maintenance or repair of this product can be dangerous and could result in injury or death.

Do not operate or perform any lubrication, maintenance or repair on this product until you have read and understood the operation, lubrication, maintenance and repair information.

Before starting any disassembly or assembly procedures, refer to *Chapter 2. Product Safety – Basic Precautions* for personal safety information.

## Machine Preparation

### ! WARNING !

Accidental machine starting can cause injury or death to personnel working on the machine.

To avoid accidental machine starting, disconnect the battery cables from the battery and tape the battery clamps and remove the key.

Place a “Do Not Operate” tag prominently on the machine to inform personnel that the machine is being worked on.

Before starting any disassembly or assembly procedures, refer to *Chapter 2. Product Safety – Repair* for machine preparation information.

## Preliminary Checkout

If troubleshooting is required prior to disassembly or assembly, refer to *Chapter 15. Troubleshooting*.

## Loader/Transmission Controls Disassembly and Assembly Procedures

Disassembly and assembly procedures are provided for the following loader/transmission control components.

- Drive Control Joystick
- Loader Control Joystick
- Loader Float Magnet
- Loader Valve

---

**Note:** Procedures are provided for only those loader/transmission control components listed above. However, information for removal and installation of other loader/transmission control components can be obtained from the Rubber Track Loader Parts List manual.

---

---

**Note:** Refer to Figure 3-2 for an overview of the auxiliary circuit system and Figure 3-3 for an overview of the drive loop system.

---

## Loader Control Joystick/Drive Control Joystick Removal and Installation

There are two joysticks that control the operation of the machine: a drive control joystick and a loader control joystick.

**Drive Control Joystick Operation** – The left-hand joystick controls the speed and direction of the machine. The further the joystick is pushed, the faster the machine travels. The joystick operates on hydraulic charge pressure. When the joystick is moved, oil is sent to the hydrostatic transmission. The transmission then delivers oil, in the correct amount, to the drive motors.

**9. Loader/Transmission Controls Disassembly and Assembly**

**Loader Control Joystick Operation** – The right-hand joystick controls the loader arm and the attachment tilt cylinder. It allows the operator to raise, lower and pivot the attachment. The joystick operates on hydraulic charge pressure.

The loader control also has a float position, which is activated by moving the joystick completely forward until it “detents”. The joystick is held in the forward float position by an electromagnet.

The tools required for loader/drive control joystick removal and installation are listed in Table 9-1. Use manufacturer-recommended tools whenever possible.

Table 9-1

Required Tools
Screwdriver
Open End Wrench

**Loader Control Joystick/Drive Control Joystick Removal**

**Note:** Since the procedures for removing both joystick controls are identical, only the loader control joystick procedure is described below.

**Note:** During disassembly, cap all hoses and fittings to prevent fluid loss and contamination of the system fluids.

**! WARNING !**

**Lower all attachments and make sure the oil is cool before removing any components or lines. Hot oil can cause personal injury.**

1. Lower the lift arms to the ground.
2. Turn the engine start switch to the OFF position.
3. Relieve hydraulic pressure from the auxiliary circuit.

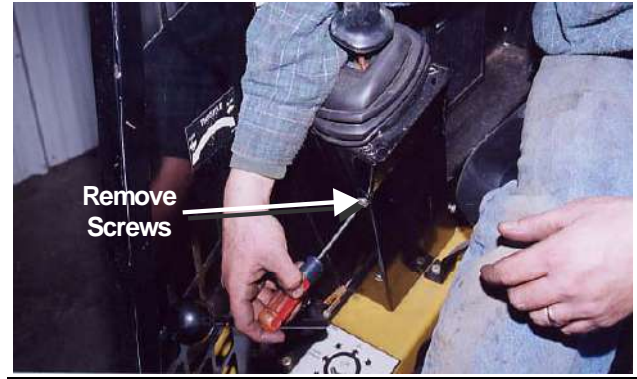

Figure 9-1

9-001

4. Remove the four retaining screws from the side cover.

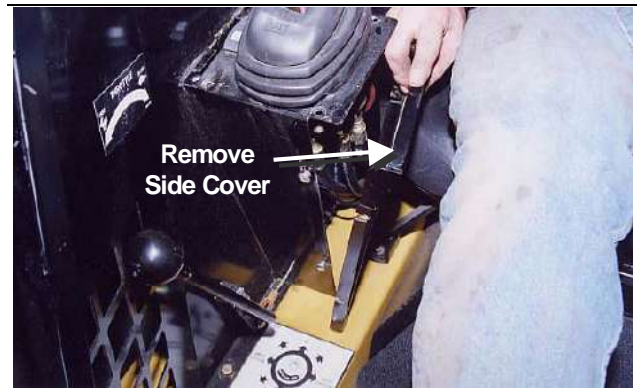

Figure 9-2

9-002

5. Remove the joystick side cover.



Figure 9-3

9-003

6. Remove the four retaining screws from the top cover.



9. Loader/Transmission Controls Disassembly and Assembly



Figure 9-4

9-004

7. Pull the joystick out of the console. The mounting plate, wiring harness and hoses will stay connected to the joystick.

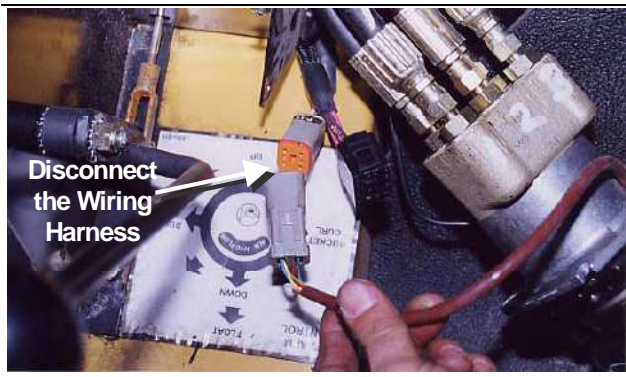

Figure 9-5

9-005

8. Disconnect the joystick wiring harness.

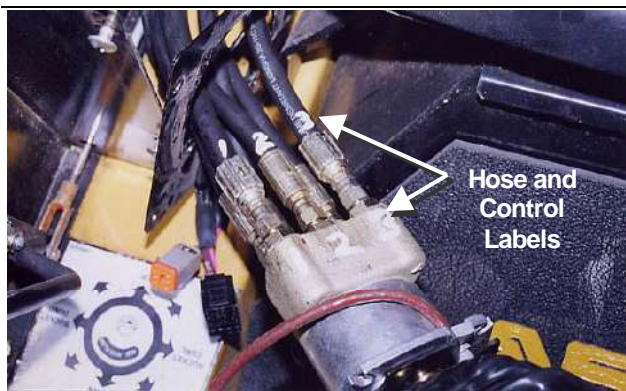

Figure 9-6

9-006

9. The hoses and the control are labeled at the factory. Make sure the labels are still legible.

10. Remove the hoses.

Loader Control Joystick/Drive Control Joystick Installation

**Note:** Since the procedures for installing both joystick controls are identical, only the loader control joystick procedure is described below.

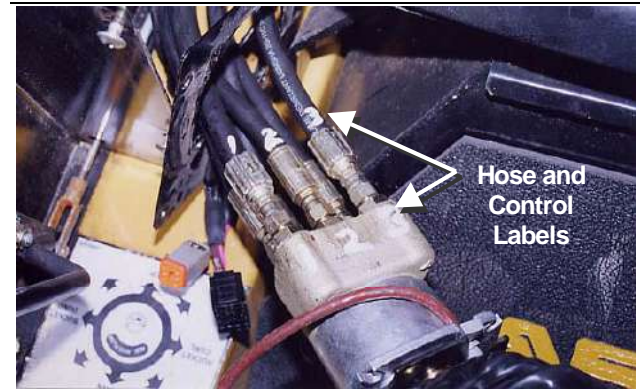

Figure 9-7

9-006

1. Match the factory labels on the hoses and the control.
2. Connect the hoses.

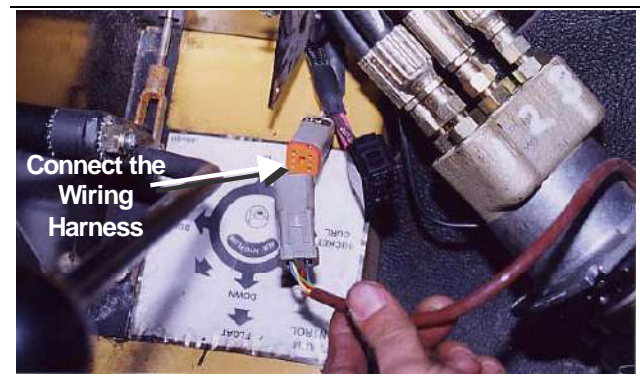

Figure 9-8

9-005

3. Connect the joystick wiring harness.

## 9. Loader/Transmission Controls Disassembly and Assembly



Figure 9-9

9-004

4. With the mounting plate, wiring harness and hoses installed, the control is ready to mount in the console.



Figure 9-10

9-003

5. Position the control on top of the console and install the four retaining screws in the top cover.

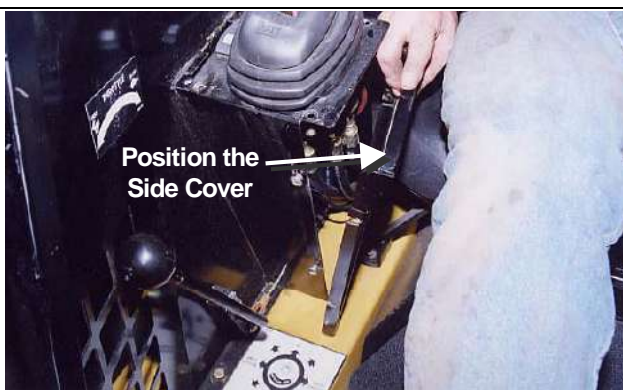

Figure 9-11

9-002

6. Place the side cover in position on the console.

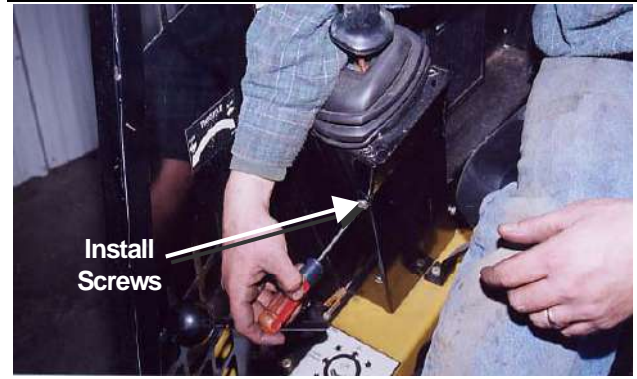

Figure 9-12

9-001

7. Install the four retaining screws in the side cover.

## Loader Float Magnet Removal and Installation

The tools required for loader float magnet removal and installation are listed in Table 9-2. Use manufacturer-recommended tools whenever possible.

Table 9-2

Required Tools
Screwdriver
Open End Wrench
Allen Wrench

## Loader Float Magnet Removal



Figure 9-13

9-001

1. Remove the four retaining screws from the side cover.



9. Loader/Transmission Controls Disassembly and Assembly

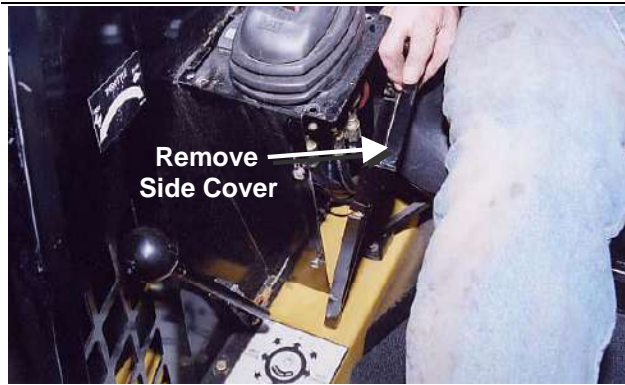

Figure 9-14

9-002

2. Remove the joystick side cover.



Figure 9-15

9-003

3. Remove the four retaining screws from the top cover.



Figure 9-16

9-007

4. Remove the rubber boot from the base of the joystick and pull the boot up.



Figure 9-17

9-008

5. Remove the control from the console and locate the loader float magnet at the front of the control.

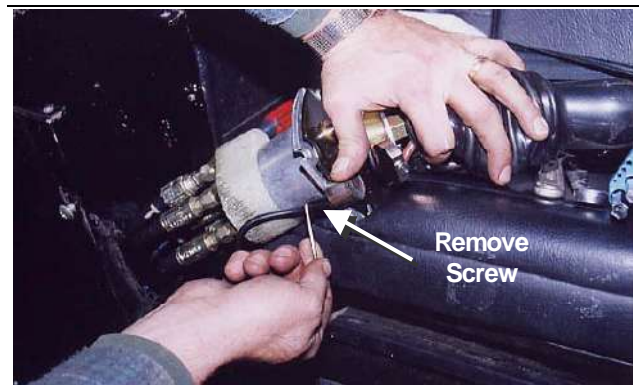

Figure 9-18

9-009

6. The loader float magnet is held in place by an allen screw at the bottom of the magnet. Remove this screw.

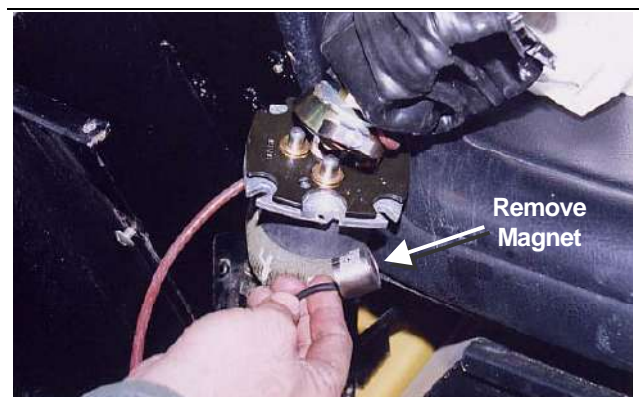

Figure 9-19

9-010

7. Remove the loader float magnet.



### Loader Float Magnet Installation

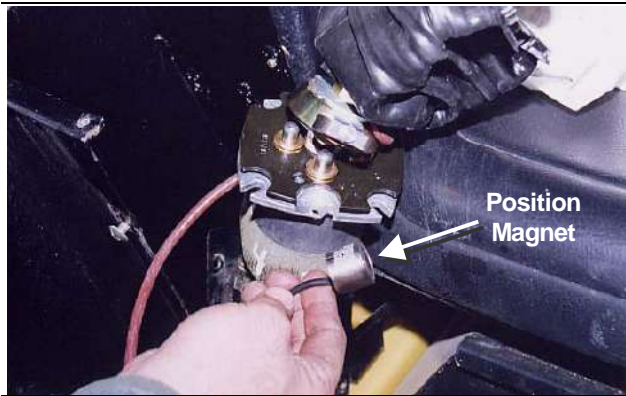

Figure 9-20

9-010

1. Position the loader float magnet at the front of the control.

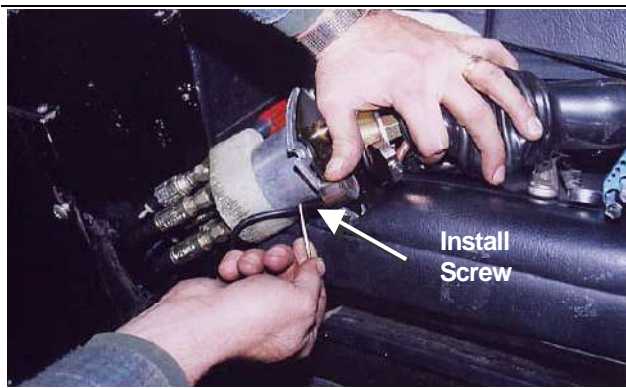

Figure 9-21

9-009

2. The loader float magnet is held in place by an allen screw at the bottom of the magnet. Install this screw.



Figure 9-22

9-008

3. With the loader float magnet installed, the control is ready to mount in the console.

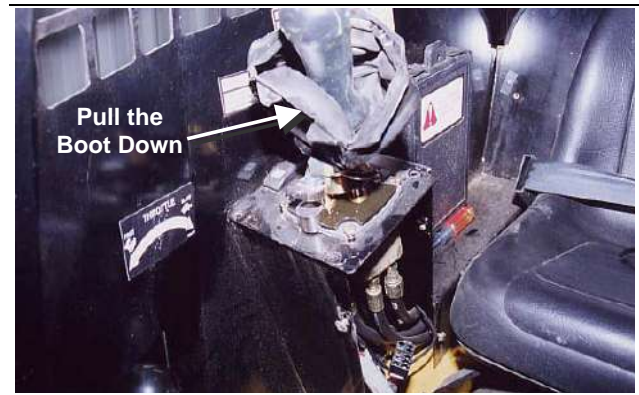

Figure 9-23

9-007

4. Position the control on the console and pull the rubber boot down over the base of the joystick.



Figure 9-24

9-003

5. Install the four retaining screws in the top cover.

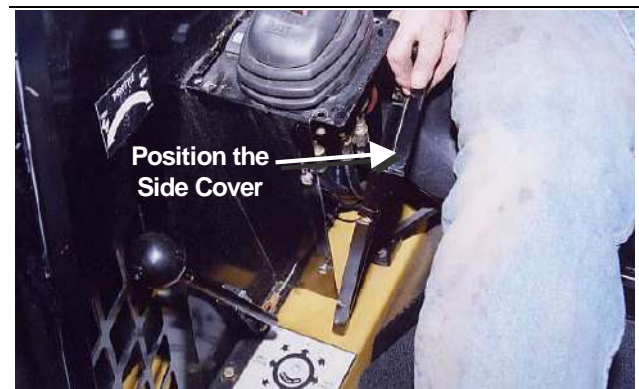

Figure 9-25

9-002

6. Place the side cover in position on the console.

9. Loader/Transmission Controls Disassembly and Assembly

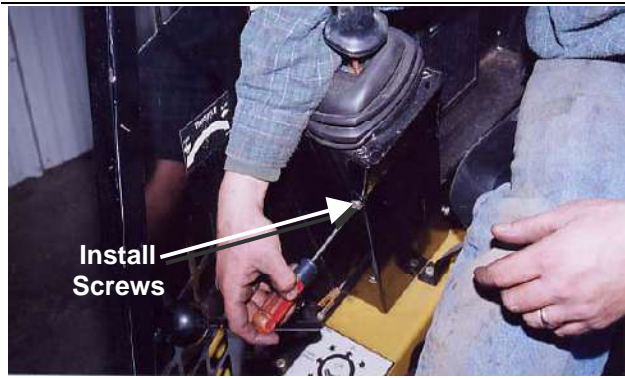

Figure 9-26

9-001

7. Install the four retaining screws in the side cover.

## Loader Valve Removal and Installation

The tools required for loader valve removal and installation are listed in Table 9-3. Use manufacturer-recommended tools whenever possible.

Table 9-3

Required Tools
Combination Wrench

### Loader Valve Removal

**! WARNING !**

Hot oil can cause personal injury. Lower all attachments and make sure the oil is cool before removing any components or lines.

Remove the oil filler cap only when the engine is stopped and the filler cap is cool enough to touch with your hands.

**NOTICE**

Collect and contain liquids in a suitable container. Dispose of all liquids according to local regulations and mandates.

**Note:** During disassembly, cap all hoses and fittings to prevent fluid loss and contamination of the system fluids.

1. Lower the lift arms to the ground.
2. Turn the engine start switch to the OFF position.
3. Relieve hydraulic pressure from the auxiliary circuit.
4. Drain the hydraulic fluid. Refer to *Chapter 16. Hydraulic Fluid and Filter Change.*

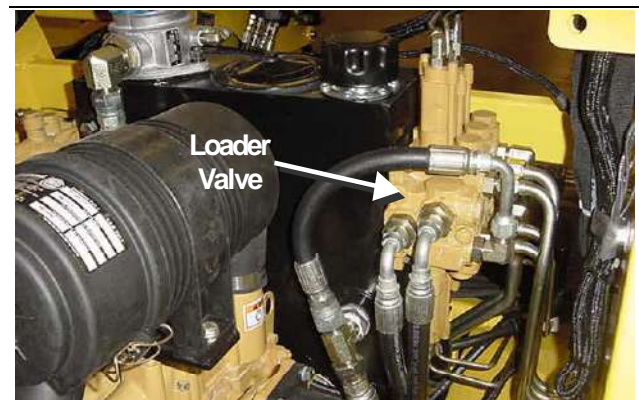

Figure 9-27

9-011

5. Locate the loader valve, which is mounted on the side of the hydraulic reservoir.

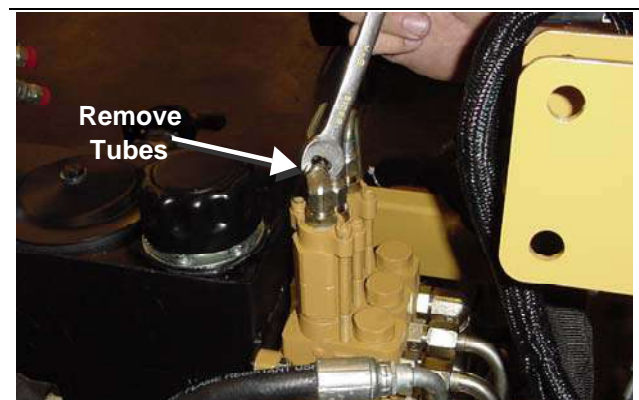

Figure 9-28

9-012

6. Remove the tubes from the top of the loader valve. Cap the tubes and fittings.



**9. Loader/Transmission Controls Disassembly and Assembly**

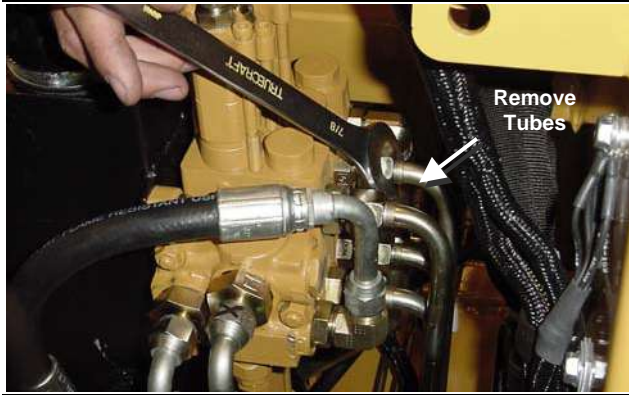

Figure 9-29

9-013

7. Remove the tubes from the side of the loader valve. Cap the tubes and fittings.

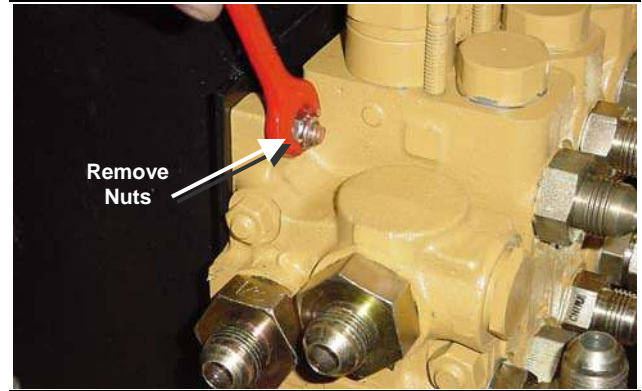

Figure 9-32

9-016

10. Remove the nuts from the four bolts that secure the loader valve to the hydraulic reservoir.

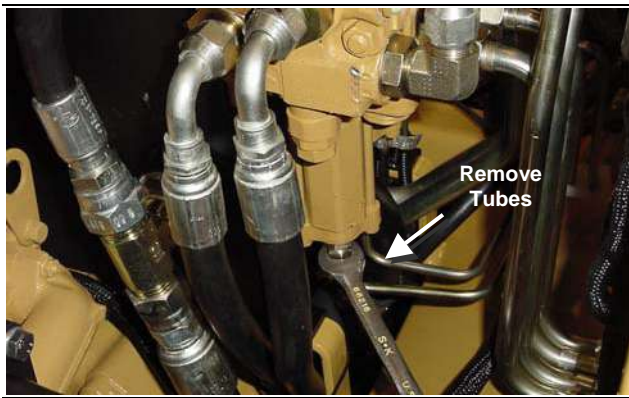

Figure 9-30

9-014

8. Remove the tubes from the bottom of the loader valve. Cap the tubes and fittings.



Figure 9-33

9-017

11. Remove the loader valve from the engine compartment.



Figure 9-31

9-015

9. Remove the hoses from the end and side of the loader valve. Cap the hoses and fittings.

### Loader Valve Installation



Figure 9-34

9-017

1. Position the loader valve against the hydraulic reservoir.

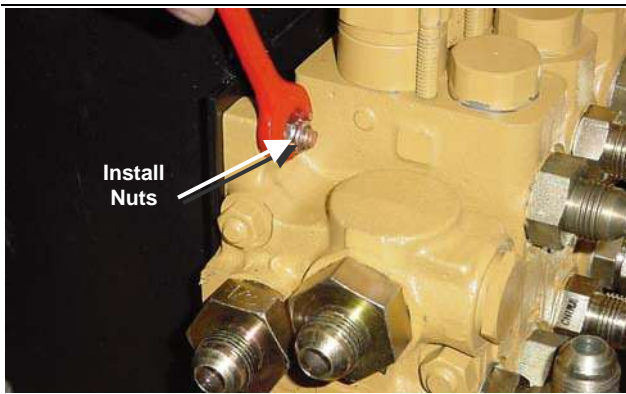

Figure 9-35

9-016

2. Install the nuts on the four bolts that secure the loader valve to the hydraulic reservoir.



Figure 9-36

9-015

3. Install the hoses on the end and side of the loader valve.

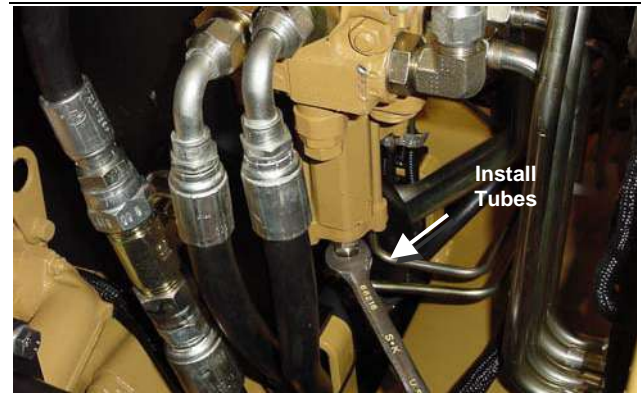

Figure 9-37

9-014

4. Install the tubes on the bottom of the loader valve.

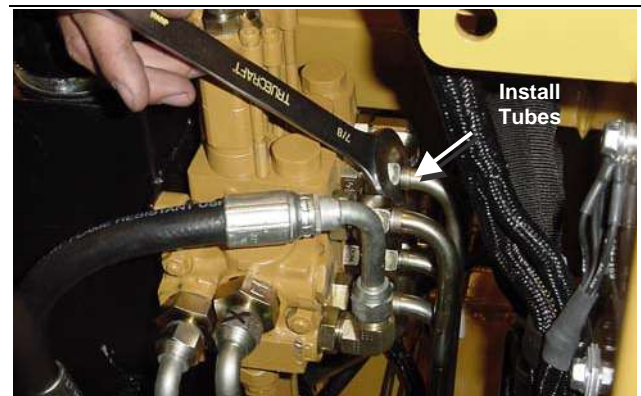

Figure 9-38

9-013

5. Install the tubes on the side of the loader valve.

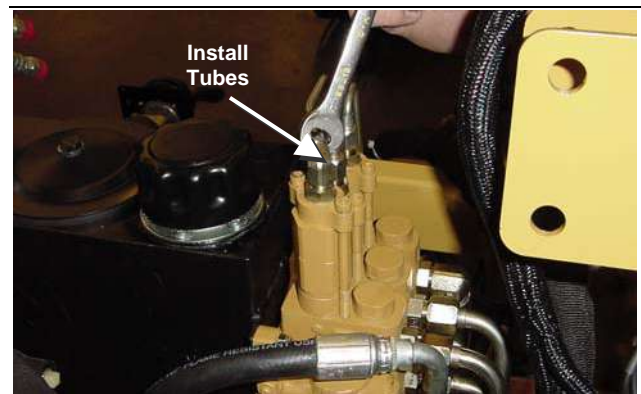

Figure 9-39

9-012

6. Install the tubes on the top of the loader valve.

7. Add manufacturer-approved hydraulic fluid.





# 10. Transmission and Drive Disassembly and Assembly

## Chapter Overview

This chapter provides disassembly and assembly procedures for the transmission and drive assembly.

## Personal Safety

### ! WARNING !

Improper operation, lubrication, maintenance or repair of this product can be dangerous and could result in injury or death.

Do not operate or perform any lubrication, maintenance or repair on this product until you have read and understood the operation, lubrication, maintenance and repair information.

Before starting any disassembly or assembly procedures, refer to *Chapter 2. Product Safety – Basic Precautions* for personal safety information.

## Machine Preparation

### ! WARNING !

Accidental machine starting can cause injury or death to personnel working on the machine.

To avoid accidental machine starting, disconnect the battery cables from the battery and tape the battery clamps and remove the key.

Place a “Do Not Operate” tag prominently on the machine to inform personnel that the machine is being worked on.

Before starting any disassembly or assembly procedures, refer to *Chapter 2. Product Safety – Repair* for machine preparation information.

## Preliminary Checkout

If troubleshooting is required prior to disassembly or assembly, refer to *Chapter 15. Troubleshooting*.

## Transmission and Drive Disassembly and Assembly Procedures

Disassembly and assembly procedures are provided for the following transmission and drive components.

- Brake Cylinders
- Drive Motors
- Auxiliary Gear Pump
- Tandem Pump
- Pump Drive Coupler

---

**Note:** Procedures are provided for only those transmission and drive components listed above. However, information for removal and installation of other transmission and drive components can be obtained from the Rubber Track Loader Parts List manual.

---

---

**Note:** Refer to Figure 3-2 for an overview of the auxiliary circuit system and Figure 3-3 for an overview of the drive loop system.

---

## Brake Cylinder Removal and Installation

Refer to *Chapter 12. Undercarriage Disassembly and Assembly – Brake Removal and Installation* for removal and installation of the brake cylinders.

## Drive Motor Removal and Installation

Refer to *Chapter 12. Undercarriage Disassembly and Assembly – Drive Motor Removal and Installation* for removal and installation of the drive motors.

## Auxiliary Gear Pump Removal and Installation

The tools required for auxiliary gear pump removal and installation are listed in Table 10-1. Use manufacturer-recommended tools whenever possible.

Table 10-1

Required Tools
Screwdriver
Combination Wrench
Socket Wrench

### Auxiliary Gear Pump Removal

#### ! WARNING !

Hot oil can cause personal injury. Lower all attachments and make sure the oil is cool before removing any components or lines.

Remove the oil filler cap only when the engine is stopped and the filler cap is cool enough to touch with your hands.

#### NOTICE

Collect and contain liquids in a suitable container. Dispose of all liquids according to local regulations and mandates.

**Note:** During disassembly, cap all hoses and fittings to prevent fluid loss and contamination of the system fluids.

1. Lower the lift arms to the ground.
2. Turn the engine start switch to the OFF position.
3. Relieve hydraulic pressure from the auxiliary circuit.
4. Drain the hydraulic fluid. Refer to *Chapter 16. Hydraulic Fluid and Filter Change*.
5. Remove the seat. Refer to *Chapter 6. Seat Removal*.
6. Remove the fuel tank. Refer to *Chapter 6. Fuel Tank Removal*.



Figure 10-1

10-001

7. View of auxiliary gear pump with seat and fuel tank removed.

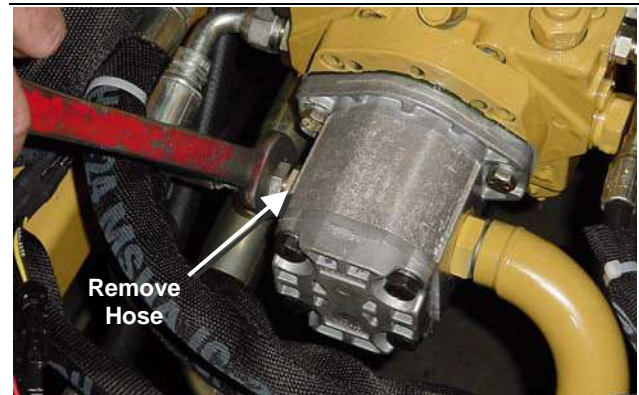

Figure 10-2

10-002

8. Remove the hose from the left side of the auxiliary gear pump.

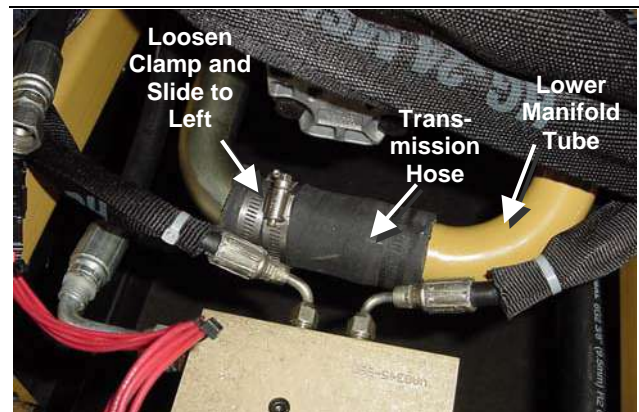

Figure 10-3

10-003

9. Loosen the clamp that secures the transmission hose to the lower manifold tube and slide the clamp to the left.

10. Transmission and Drive Disassembly and Assembly

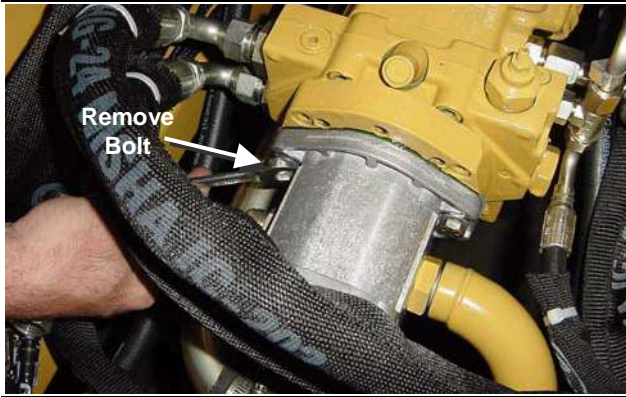

Figure 10-4

10-004

10. Remove the bolt on the left side of the auxiliary gear pump.



Figure 10-5

10-005

11. Remove the bolt on the right side of the auxiliary gear pump.



Figure 10-6

10-006

12. Remove the auxiliary gear pump by sliding the lower manifold tube out of the transmission hose.

**Note:** It is not necessary to separate the lower manifold tube from the gear pump: this can be done after the pump is removed, if necessary.

Auxiliary Gear Pump Installation

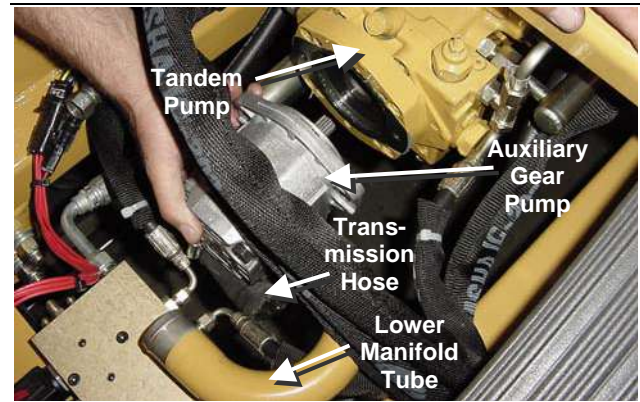

Figure 10-7

10-006

1. With the lower manifold tube attached to the auxiliary gear pump, align the mounting bolt holes in the auxiliary gear pump with the holes in the tandem pump. It will be necessary to slide the manifold tube into the transmission hose to properly position the auxiliary gear pump.



Figure 10-8

10-005

2. Install the bolt on the right side of the auxiliary gear pump.



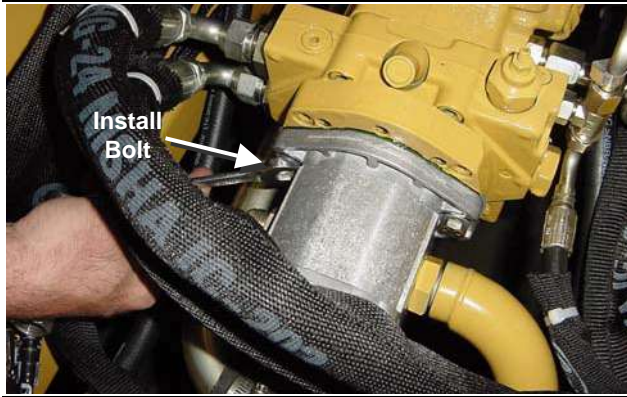

Figure 10-9

10-004

3. Install the bolt on the left side of the auxiliary gear pump.

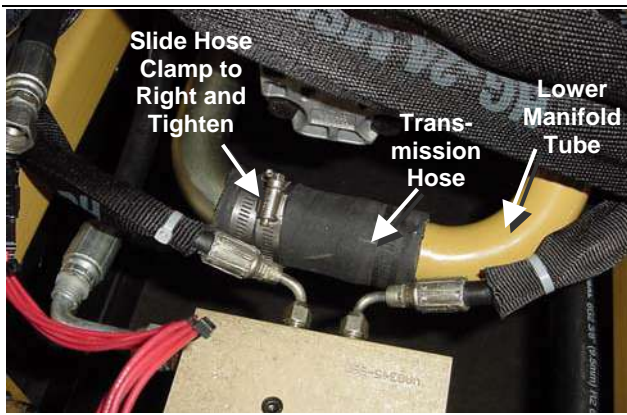

Figure 10-10

10-003

4. With the end of the lower manifold tube inserted in the transmission hose, slide the hose clamp to the right and tighten the clamp.
5. Install the fuel tank. Refer to *Chapter 6. Fuel Tank Installation*.
6. Install the seat. Refer to *Chapter 6. Seat Installation*.
7. Add fuel and manufacturer-approved hydraulic fluid.

## Tandem Pump Removal and Installation

The tools required for tandem pump removal and installation are listed in Table 10-2. Use manufacturer-recommended tools whenever possible.

Table 10-2

Required Tools
Screwdriver
Combination Wrench
Socket Wrench

### Tandem Pump Removal

#### ! WARNING !

Hot oil can cause personal injury. Lower all attachments and make sure the oil is cool before removing any components or lines.

Remove the oil filler cap only when the engine is stopped and the filler cap is cool enough to touch with your hands.

#### NOTICE

Collect and contain liquids in a suitable container. Dispose of all liquids according to local regulations and mandates.

**Note:** During disassembly, cap all hoses and fittings to prevent fluid loss and contamination of the system fluids.

1. Lower the lift arms to the ground.
2. Turn the engine start switch to the OFF position.
3. Relieve hydraulic pressure from the auxiliary circuit.
4. Drain the hydraulic fluid. Refer to *Chapter 16. Hydraulic Fluid and Filter Change*.
5. Remove the seat. Refer to *Chapter 6. Seat Removal*.
6. Remove the fuel tank. Refer to *Chapter 6. Fuel Tank Removal*.
7. Remove the auxiliary gear pump. Refer to *Chapter 10. Auxiliary Gear Pump Removal*.

10. Transmission and Drive Disassembly and Assembly

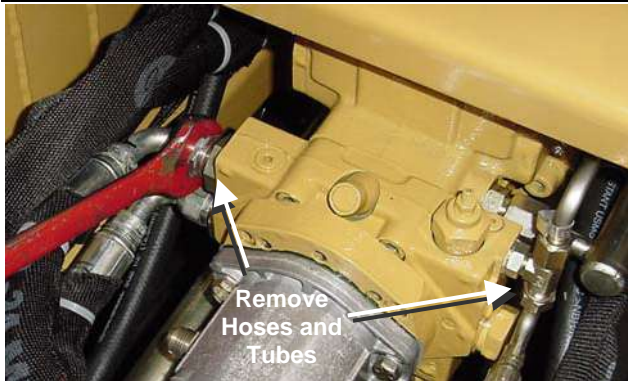

Figure 10-11

10-007

8. Remove all hoses and tubes from the tandem pump. Cap the hoses and tubes.

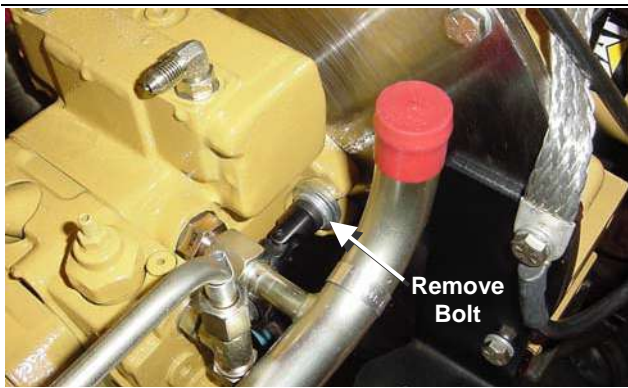

Figure 10-12

10-008

9. Remove the mounting bolt (with spring lock washer and flat washer) from the right-hand side of the tandem pump.



Figure 10-13

10-009

10. Remove the mounting bolt (with spring lock washer and flat washer) from the left-hand side of the tandem pump.

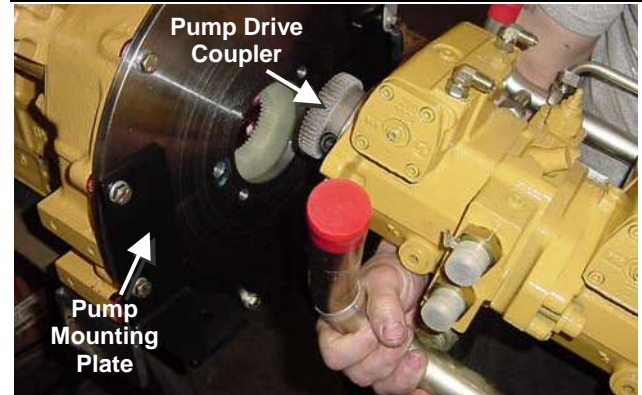

Figure 10-14

10-010

11. Remove the tandem pump (with pump drive coupler attached) from the pump mounting plate.

Tandem Pump Installation

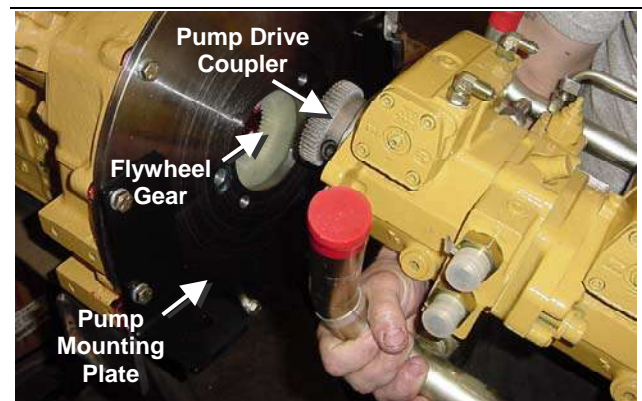

Figure 10-15

10-010

1. With the pump drive coupler attached to the tandem pump, position the tandem pump against the pump mounting plate. Make sure the teeth on the pump drive coupler mesh properly with the flywheel gear teeth.



10. Transmission and Drive Disassembly and Assembly

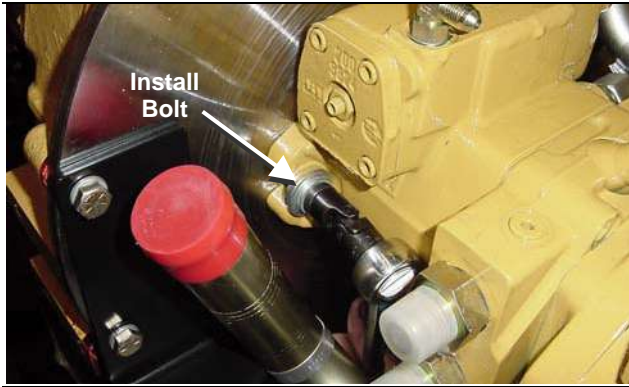

Figure 10-16

10-009

2. Install the mounting bolt (with spring lock washer and flat washer) on the left-hand side of the tandem pump.

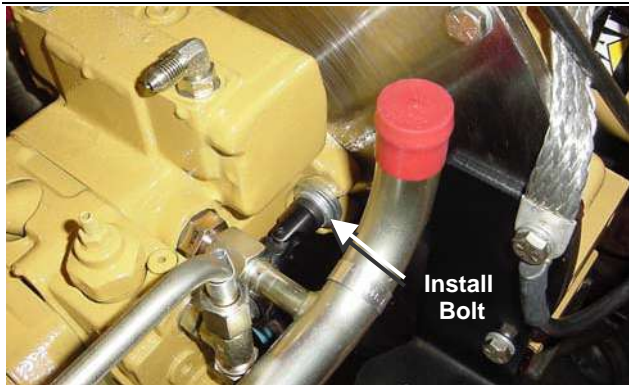

Figure 10-17

10-008

3. Install the mounting bolt (with spring lock washer and flat washer) on the right-hand side of the tandem pump.

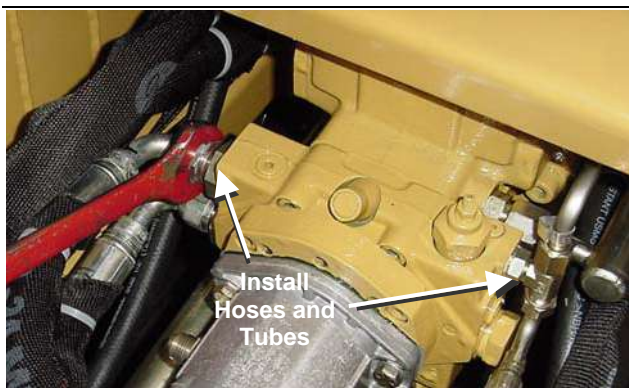

Figure 10-18

10-007

4. Install the hoses and tubes on the tandem pump.

5. Install the auxiliary gear pump. Refer to *Chapter 10. Auxiliary Gear Pump Installation*.
6. Install the fuel tank. Refer to *Chapter 6. Fuel Tank Installation*.
7. Install the seat. Refer to *Chapter 6. Seat Installation*.
8. Add fuel and manufacturer-approved hydraulic fluid.

## Pump Drive Coupler Removal and Installation

The tools required for pump drive coupler removal and installation are listed in Table 10-3. Use manufacturer-recommended tools whenever possible.

Table 10-3

Required Tools
Screwdriver
Combination Wrench
Socket Wrench

## Pump Drive Coupler Removal

**! WARNING !**

**Hot oil can cause personal injury. Lower all attachments and make sure the oil is cool before removing any components or lines.**

**Remove the oil filler cap only when the engine is stopped and the filler cap is cool enough to touch with your hands.**

### NOTICE

Collect and contain liquids in a suitable container. Dispose of all liquids according to local regulations and mandates.

**Note:** During disassembly, cap all hoses and fittings to prevent fluid loss and contamination of the system fluids.

1. Lower the lift arms to the ground.
2. Turn the engine start switch to the OFF position.
3. Relieve hydraulic pressure from the auxiliary circuit.

10. Transmission and Drive Disassembly and Assembly

4. Drain the hydraulic fluid. Refer to *Chapter 16. Hydraulic Fluid and Filter Change.*
5. Remove the seat. Refer to *Chapter 6. Seat Removal.*
6. Remove the fuel tank. Refer to *Chapter 6. Fuel Tank Removal.*
7. Remove the auxiliary gear pump. Refer to *Chapter 10. Auxiliary Gear Pump Removal.*
8. Remove the tandem pump. Refer to *Chapter 10. Tandem Pump Removal.*

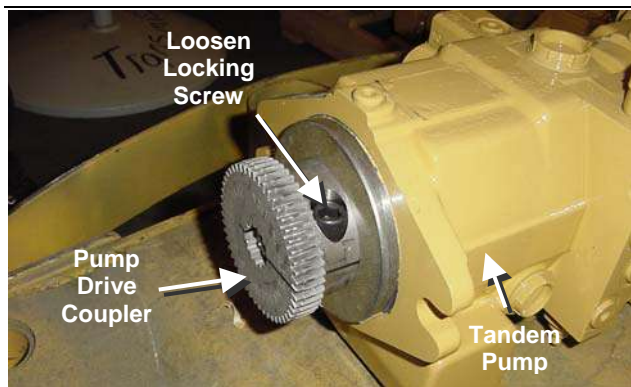

Figure 10-19

10-011

9. Loosen the locking screw that secures the pump drive coupler to the drive shaft extending from the end of the tandem pump.

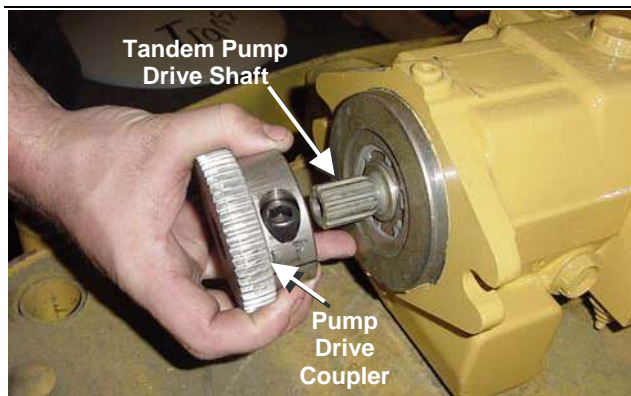

Figure 10-20

10-012

10. Slide the pump drive coupler off the tandem pump drive shaft.

Pump Drive Coupler Installation

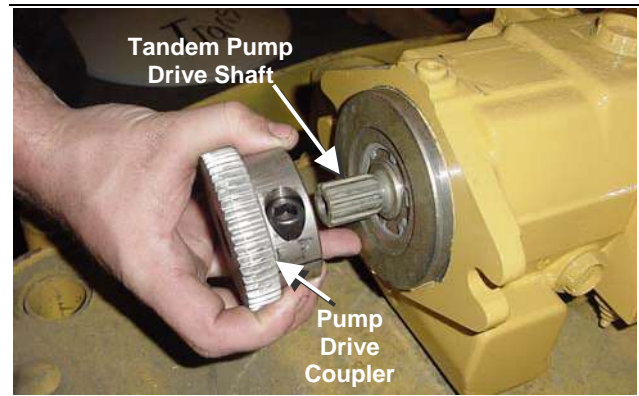

Figure 10-21

10-012

1. Slide the pump drive coupler all the way onto the tandem pump drive shaft.

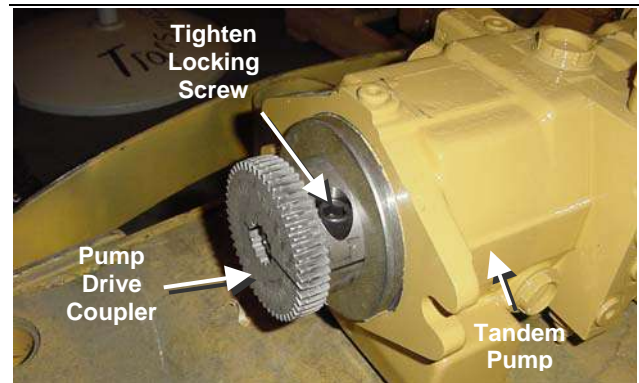

Figure 10-22

10-011

2. Tighten the locking screw that secures the pump drive coupler to the tandem pump drive shaft.
3. Install the tandem pump. Refer to *Chapter 10. Tandem Pump Installation.*
4. Install the auxiliary gear pump. Refer to *Chapter 10. Auxiliary Gear Pump Installation.*
5. Install the fuel tank. Refer to *Chapter 6. Fuel Tank Installation.*
6. Install the seat. Refer to *Chapter 6. Seat Installation.*
7. Add fuel and manufacturer-approved hydraulic fluid.





# 11. Engine Components Disassembly and Assembly

## Chapter Overview

This chapter provides disassembly and assembly procedures for the engine components.

## Personal Safety

**! WARNING !**

Improper operation, lubrication, maintenance or repair of this product can be dangerous and could result in injury or death.

Do not operate or perform any lubrication, maintenance or repair on this product until you have read and understood the operation, lubrication, maintenance and repair information.

Before starting any disassembly or assembly procedures, refer to *Chapter 2. Product Safety – Basic Precautions* for personal safety information.

## Machine Preparation

**! WARNING !**

Accidental machine starting can cause injury or death to personnel working on the machine.

To avoid accidental machine starting, disconnect the battery cables from the battery and tape the battery clamps and remove the key.

Place a “Do Not Operate” tag prominently on the machine to inform personnel that the machine is being worked on.

Before starting any disassembly or assembly procedures, refer to *Chapter 2. Product Safety – Repair* for machine preparation information.

## Preliminary Checkout

If troubleshooting is required prior to disassembly or assembly, refer to *Chapter 15. Troubleshooting*.

## Engine Components Disassembly and Assembly Procedures

Disassembly and assembly procedures are provided for the following engine components.

- Muffler
- Battery
- Exhaust Pipe
- Bleeding the Fuel System

---

**Note:** Procedures are provided for only those engine components listed above. However, information for removal and installation of other engine components can be obtained from the Rubber Track Loader Parts List manual.

---

## Primary Air Filter Removal and Installation

Refer to *Chapter 16. Maintenance – Air Cleaner* for removal and installation of the primary air filter.

## Safety Air Filter Removal and Installation

Refer to *Chapter 16. Maintenance – Air Cleaner* for removal and installation of the safety air filter.

## Engine Oil Filter Removal and Installation

Refer to *Chapter 16. Maintenance – Engine Oil* for removal and installation of the engine oil filter.

## Fuel Filter Removal and Installation

Refer to *Chapter 16. Maintenance – Fuel Filter* for removal and installation of the fuel filter.

## Muffler Removal and Installation

The tools required for muffler removal and installation are listed in Table 11-1. Use manufacturer-recommended tools whenever possible.

Table 11-1

Required Tools
Socket Wrench
Combination Wrench
Channel Lock Pliers

### Muffler Removal

**! CAUTION !**

The muffler gets very hot during operation. Do not service the muffler until it is cool enough to touch.

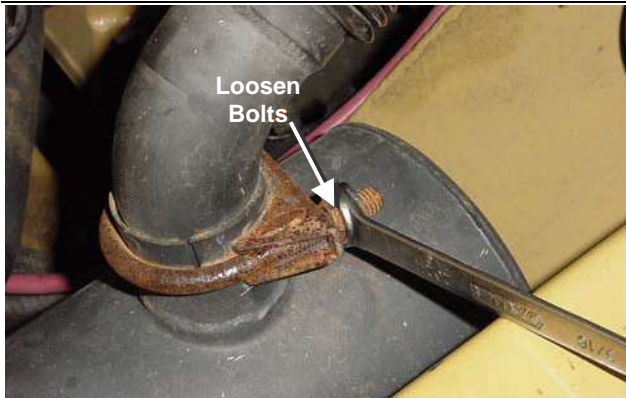

Figure 11-1

11-001

1. Loosen the bolts on the muffler clamp.



Figure 11-2

11-002

2. Using the channel lock, slide the flex pipe off the muffler.

### NOTICE

Do not kink or twist the exhaust pipe. One end of the exhaust pipe is attached to the muffler, which is fixed to the frame. The other end is attached to the engine, which vibrates during operation. Kinks or twists in the exhaust pipe could cause premature failure.

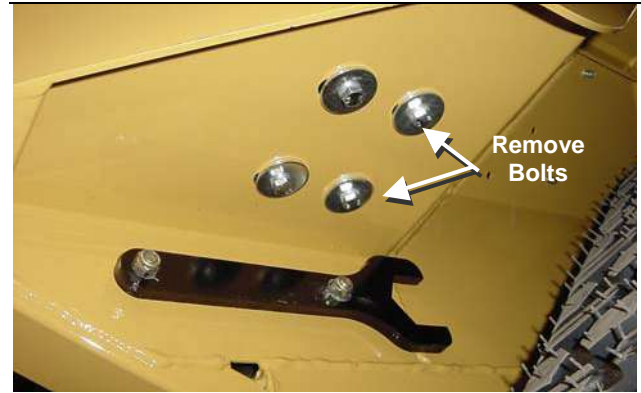

Figure 11-3

11-003

3. From underneath the machine, remove the four bolts that fasten the muffler to the frame.
4. Remove the muffler from the engine compartment.

### Muffler Installation

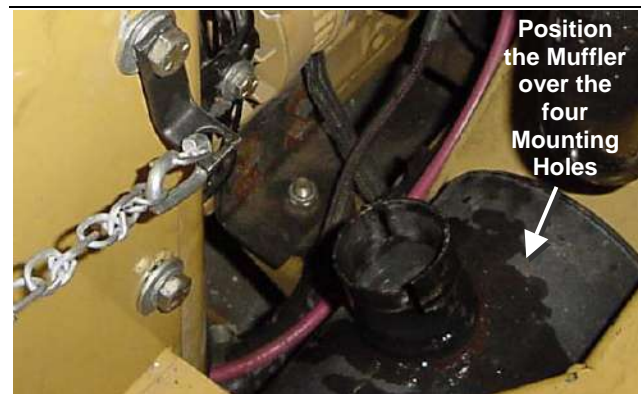

Figure 11-4

11-002

1. Guide the end of the exhaust pipe through the opening in the rear frame structure and position the muffler over the four muffler mounting holes.

11. Engine Components Disassembly and Assembly

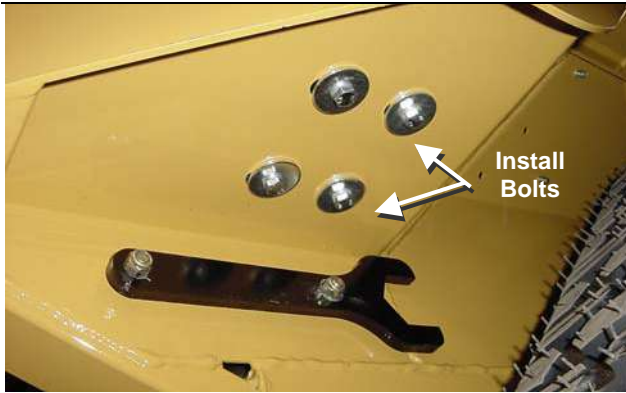

Figure 11-5

11-003

2. From underneath the machine, install the four muffler mounting bolts, making sure all, if any, shims are in place.



Figure 11-6

11-002

3. Carefully slide the flex pipe over the muffler extension.

**NOTICE**

Do not kink or twist the exhaust pipe. One end of the exhaust pipe is attached to the muffler, which is fixed to the frame. The other end is attached to the engine, which vibrates during operation. Kinks or twists in the exhaust pipe could cause premature failure.

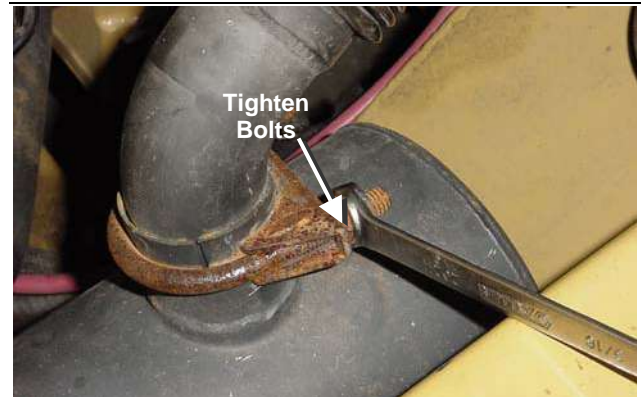

Figure 11-7

11-001

4. Tighten the bolts on the muffler clamp.

**Exhaust Flex Pipe Removal and Installation**

The tools required for exhaust flex pipe removal and installation are listed in Table 11-2. Use manufacturer-recommended tools whenever possible.

Table 11-2

Required Tools
Socket Wrench
Combination Wrench
Channel Lock Pliers

**Exhaust Flex Pipe Removal**

**! CAUTION !**

The exhaust pipe gets very hot during operation. Do not service the exhaust pipe until it is cool enough to touch.

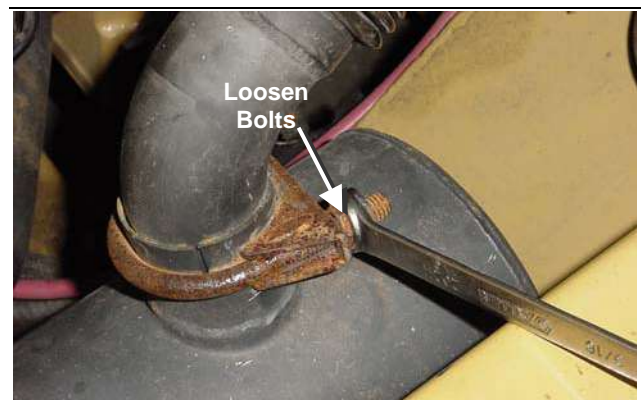

Figure 11-8

11-001

1. Loosen the bolts on the muffler clamp



## 11. Engine Components Disassembly and Assembly

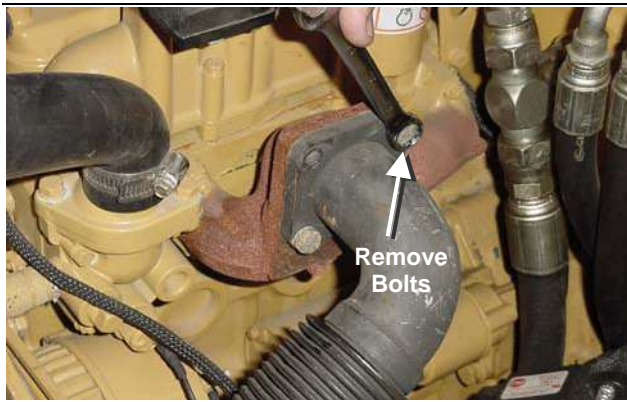

Figure 11-9

11-004

2. Remove the four bolts that secure the exhaust flex pipe to the exhaust manifold.



Figure 11-10

11-002

3. Using the Channel locks, slide the exhaust pipe off the muffler.

### NOTICE

Do not kink or twist the exhaust pipe. One end of the exhaust pipe is attached to the muffler, which is fixed to the frame. The other end is attached to the engine, which vibrates during operation. Kinks or twists in the exhaust pipe could cause premature failure.



Figure 11-11

11-005

4. Remove the exhaust flex pipe gasket from the exhaust manifold.

---

**Note:** The gasket may come off with the exhaust pipe.

---

## Exhaust Pipe Installation



Figure 11-12

11-002

1. Carefully slide the exhaust pipe over the muffler extension. Do not tighten the clamp yet.

### NOTICE

Do not kink or twist the exhaust pipe. One end of the exhaust pipe is attached to the muffler, which is fixed to the frame. The other end is attached to the engine, which vibrates during operation. Kinks or twists in the exhaust pipe could cause premature failure.



Figure 11-13

11-005

2. Place the exhaust flex pipe gasket in position.

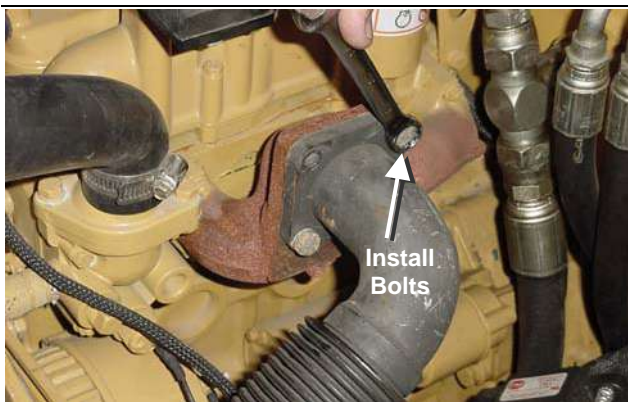

Figure 11-14

11-004

3. With the exhaust pipe gasket in place, install the four bolts that secure the exhaust pipe to the exhaust manifold.

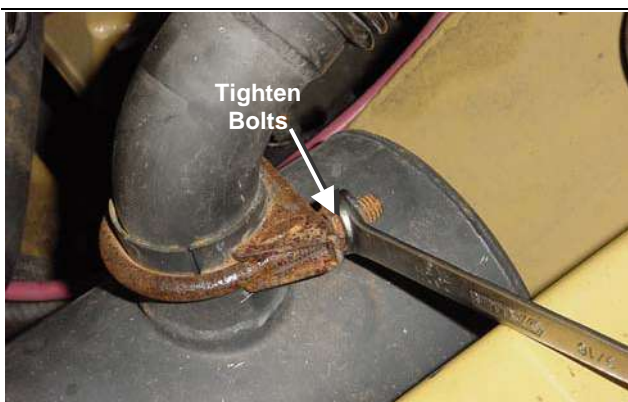

Figure 11-15

11-001

4. Make sure there are no kinks or bends in the muffer, then tighten the bolts on the muffer clamp.

## Battery Removal and Installation

The tools required for battery removal and installation are listed in Table 11-3. Use manufacturer-recommended tools whenever possible.

Table 11-3

Required Tools
Combination Wrench
Socket Wrench

### Battery Removal

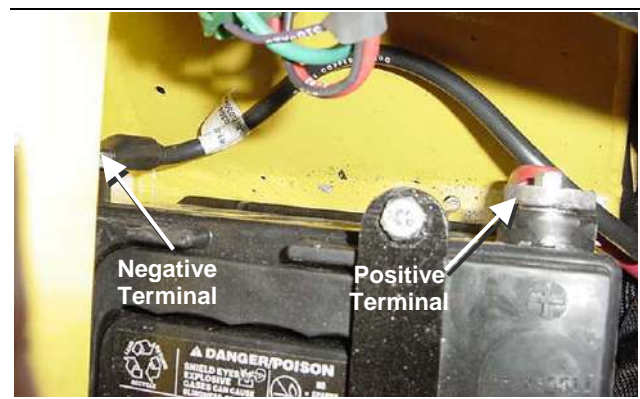

Figure 11-16

11-006

1. Identify the positive and negative battery terminals.

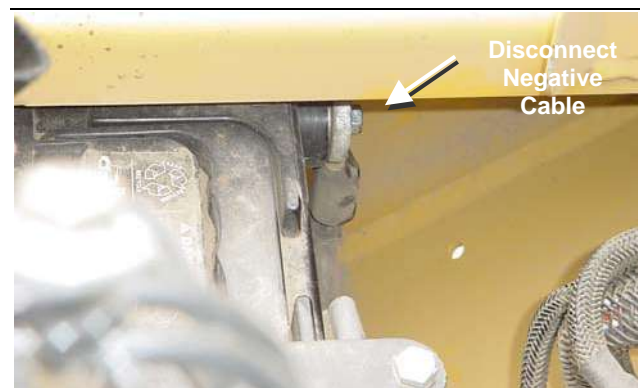

Figure 11-17

11-007

2. Disconnect the battery cable from the negative battery terminal.



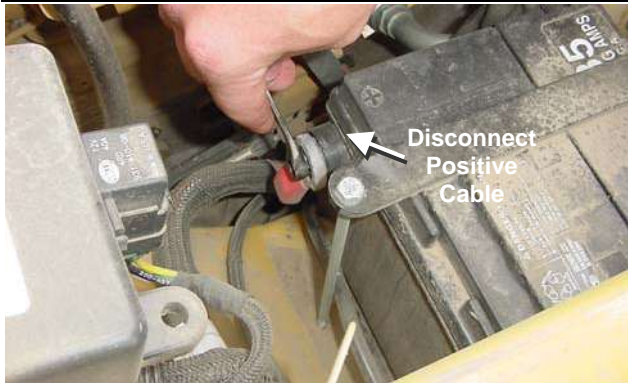

Figure 11-18

11-008

3. Disconnect the battery cable from the positive battery terminal.



Figure 11-19

11-009

4. Remove the two capscrews from the battery holddown bracket and remove the bracket.



Figure 11-20

11-010

5. Rotate the battery 90 degrees counter-clockwise. Tilt up the front of the battery and remove the battery from the machine.

## Battery Installation



Figure 11-21

11-011

1. Place the battery in position in the engine compartment.



Figure 11-22

11-009

2. Position the battery holddown bracket and install the two capscrews and nuts.

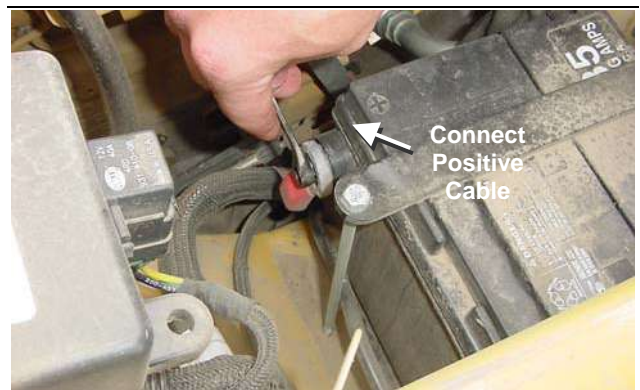

Figure 11-23

11-008

3. Connect the battery cable to the positive battery terminal.

11. Engine Components Disassembly and Assembly

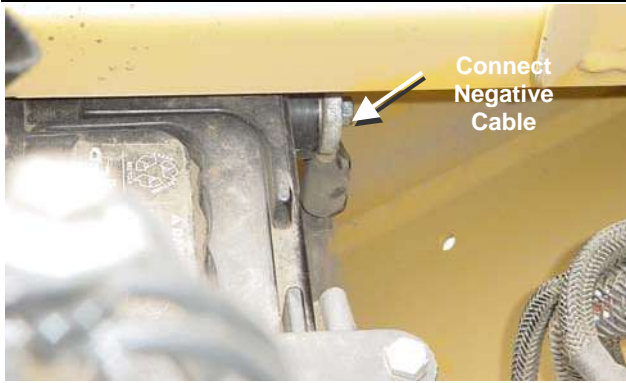

Figure 11-24

11-007

4. Connect the battery cable to the negative battery terminal.

### Bleeding the Fuel System

The tools required for muffler removal and installation are listed in Table 11-1. Use manufacturer-recommended tools whenever possible.

Table 11-4

Required Tools
Combination Wrench

If the machine has been run out of fuel, it may be necessary to bleed the fuel system. There are two types of bleeding methods depending on the serial number of your machine.

For serial numbers 001 through 1357.



Figure 11-25

11-006

1. Locate the bleed screw directly above the fuel injectors.
2. Loosen the bleed screw two full turns

3. Turn-over the engine from the operators compartment until fuel is flowing from the bleed screw without any air bubbles.
4. Tighten the bleed screw.
5. Engine should now start within 10 seconds.

For serial numbers 1358 and higher.

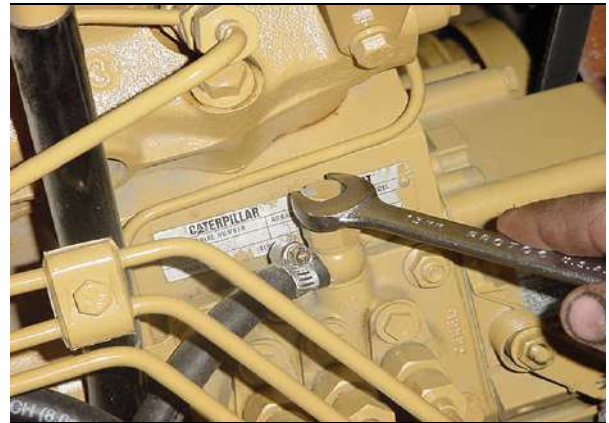

Figure 11-26

11-005

1. Locate the bleed screw directly above the fuel injectors.
2. Loosen the bleed screw two full turns.



Figure 11-27

11-004

3. Pump the bulb primer with your hand until fuel flows from the bleed screw without any air bubbles.
4. Tighten the bleed screw.





# 12. Undercarriage Disassembly and Assembly

## Chapter Overview

This chapter provides disassembly and assembly procedures for the following undercarriage assemblies.

- Track
- Suspension

## Personal Safety

**! WARNING !**

Improper operation, lubrication, maintenance or repair of this product can be dangerous and could result in injury or death.

Do not operate or perform any lubrication, maintenance or repair on this product until you have read and understood the operation, lubrication, maintenance and repair information.

Before starting any disassembly or assembly procedures, refer to *Chapter 2. Product Safety – Basic Precautions* for personal safety information.

## Machine Preparation

**! WARNING !**

Accidental machine starting can cause injury or death to personnel working on the machine.

To avoid accidental machine starting, disconnect the battery cables from the battery and tape the battery clamps and remove the key.

Place a “Do Not Operate” tag prominently on the machine to inform personnel that the machine is being worked on.

Before starting any disassembly or assembly procedures, refer to *Chapter 2. Product Safety – Repair* for machine preparation information.

## Preliminary Checkout

If troubleshooting is required prior to disassembly or assembly, refer to *Chapter 15. Troubleshooting*.

## Undercarriage Disassembly and Assembly Procedures

Disassembly and assembly procedures are provided for the following undercarriage components.

- Wheels
- Sprockets
- Sprocket rollers
- Sprocket bearing plates
- Brakes
- Tracks
- Drive motors

**Note:** Procedures are provided for only those undercarriage components listed above. However, information for removal and installation of other undercarriage components can be obtained from the Rubber Track Loader Parts List manual.

## Wheel Removal and Installation

The tools required for wheel removal and installation are listed in Table 12-1. Use manufacturer-recommended tools whenever possible.

Table 12-1

Required Tools
Wheel Extractor
Channel Lock Pliers
Socket Wrench
Snap-ring Pliers

## Wheel Removal

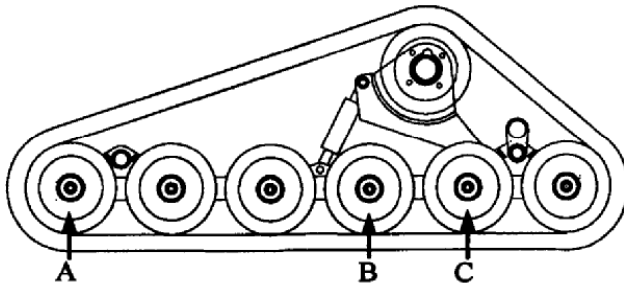

Figure 12-1

12-004

1. Locate the wheels marked A, B, and C. If the track is to be removed, wheels A, B, and the wheel to the inside of B must be removed. If the brake is to be replaced, wheel C must be removed.



Figure 12-2

12-005

2. Use a snap-ring pliers to remove the snap ring that secures the wheel cap.



Figure 12-3

12-006

3. Using a large channel lock pliers, remove the wheel cap.

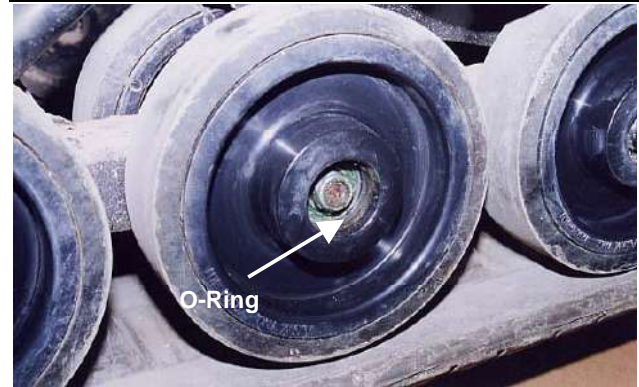

Figure 12-4

12-007

4. Remove the o-ring from inside the wheel.



Figure 12-5

12-008

5. Using a socket, remove the nut that fastens the wheel to the shaft. Remove the wheel with a wheel extractor.



Figure 12-6

12-009

6. To remove an inside wheel, the machine must be positioned securely on jack-stands. Slide under the machine and repeat the wheel removal procedure.



12. Undercarriage Disassembly and Assembly



Figure 12-7 12-010

7. With wheels removed, inspect the axle for wear or damage.

Wheel Installation



Figure 12-8 12-049

1. Mount the wheel on the shaft. In this illustration the front outside wheel is shown, but the procedure is the same for all wheels



Figure 12-9 12-016

2. Install the wheel nut on the shaft.



Figure 12-10 12-051

3. Insert the o-ring into the wheel, seating it against the outside bearing race. Make sure there is adequate grease inside the bearing, but remove excess grease in the area of the o-ring. Install the wheel cap and snap-ring. Make sure the snap-ring is fully seated in its groove.

Sprocket Roller Removal and Installation

The tools required for sprocket roller removal and installation are listed in Table 12-2. Use manufacturer-recommended tools whenever possible.

Table 12-2

Required Tools
Socket Wrench
Combination Wrench

**Note:** The rollers should be inspected every 25 hours for rotation and wear-through. The rollers on the drive sprocket are easily replaceable. The track DOES NOT need to be removed to replace these rollers.

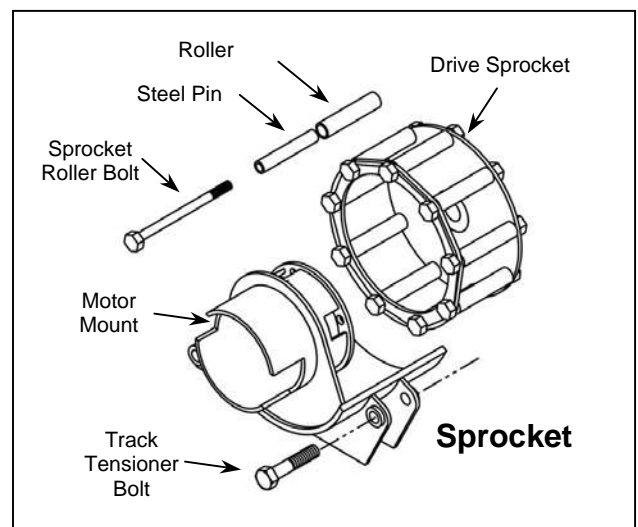

**Sprocket Roller Removal**



Figure 12-11 12-057

1. Rotate the drive sprocket to allow access to the sprocket roller bolt. Remove the bolt.



Figure 12-12 12-058

2. Remove the roller and steel pin from the drive sprocket.

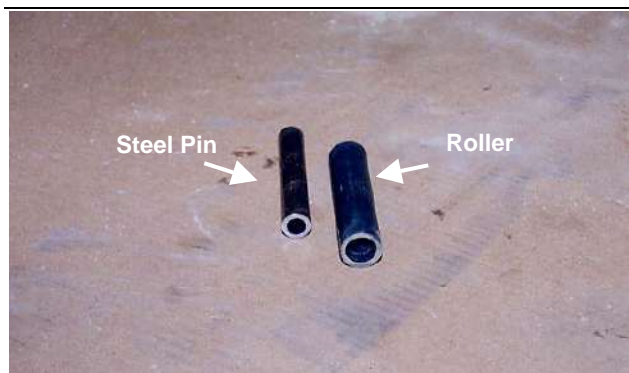

Figure 12-13 12-019

3. Inspect the rollers for wear and replace as necessary. The steel pin will normally not need replacing unless the roller has worn completely away and the steel pin is worn from engaging the track.

**Sprocket Roller Installation**



Figure 12-14 12-059

1. With the drive sprocket rotated to the desired position, position the composite roller and steel roller in the drive sprocket.



Figure 12-15 12-060

2. Insert the sprocket roller bolt with the nut facing out and tighten.

**Brake Removal and Installation**

The tools required for brake removal and installation are listed in Table 12-3. Use manufacturer-recommended tools whenever possible.

Table 12-3

Required Tools
Socket Wrench
Combination Wrench



## Brake Removal

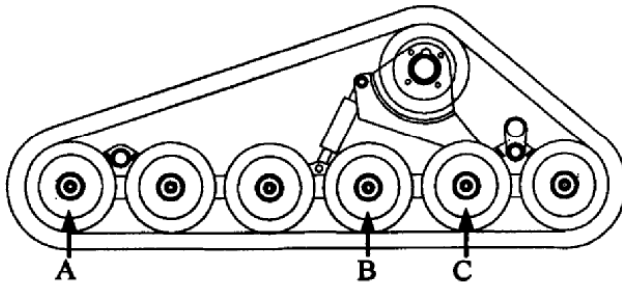

Figure 12-16

12-004

1. Locate the wheel marked C located directly behind the drive sprocket. If the brake is to be replaced, this wheel must also be removed.



Figure 12-17

12-020

2. Remove the outside wheel marked C in step 1. Refer to *Chapter 12. Wheel Removal*.



Figure 12-18

12-021

3. Remove the two bolts that fasten the brake cylinder to the rail.

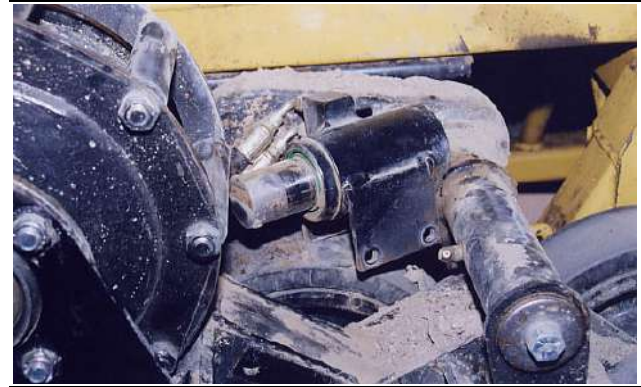

Figure 12-19

12-022

4. Move the brake cylinder out from the sprocket. If replacing the brake cylinder, clean and disconnect the hoses going to the cylinder. Cap the hoses until the new brake is ready to install.

## Brake Installation

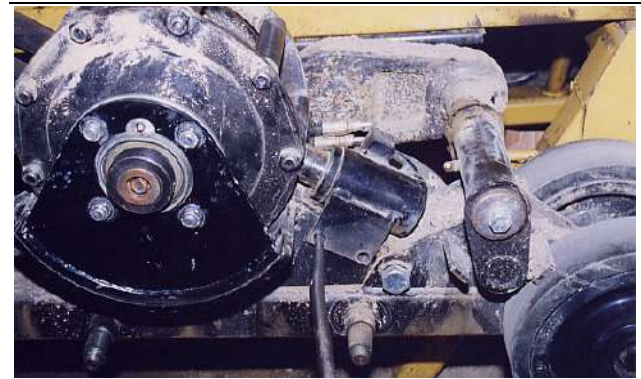

Figure 12-20

12-046

1. Using a drift pin or punch, line up the holes in the brake cylinder with the holes in the rail. If needed, rotate the sprocket until the cylinder ram is between two drive pins.



12. Undercarriage Disassembly and Assembly

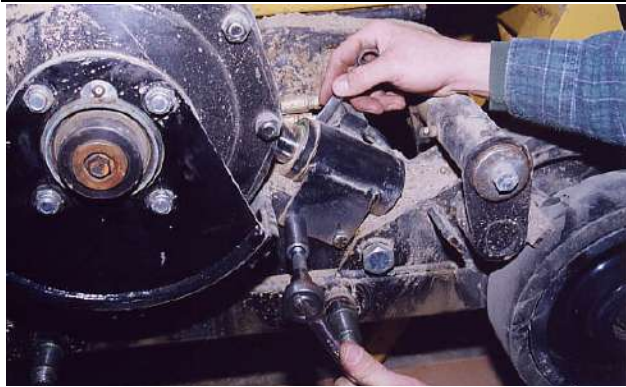

Figure 12-21

12-021

2. Insert and tighten the two bolts that fasten the brake cylinder to the rail.
3. Replace the outside wheel directly behind the drive sprocket. Refer to *Chapter 12. Wheel Installation*.

## Track Removal and Installation

The tools required for track removal and installation are listed in Table 12-4. Use manufacturer-recommended tools whenever possible.

Table 12-4

Required Tools	
Socket Wrench	Floor Jack
Combination Wrench	Straight Edge
Crowbar	Tape Measure

### Track Removal

**! WARNING !**

To remove the tracks, the machine must be jacked up and placed on jack stands sturdy enough to support the weight of the machine. The manufacturer-supplied jack stands are recommended.

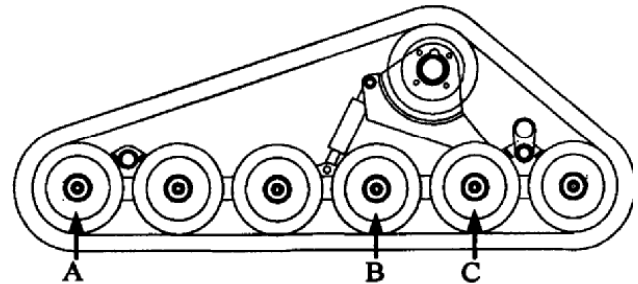

Figure 12-22

12-004

1. Locate the wheels marked A and B. If the track is to be removed, these wheels and the wheel to the inside of B must also be removed.



Figure 12-23

12-016

2. Remove the wheels located in step 1. Refer to *Chapter 12. Wheel Removal*.



Figure 12-24

12-011

3. Loosen the jam nut located on the track tensioner. A field wrench located under the right fender of the machine can be used, but a standard wrench is preferred for shop use.



Figure 12-25

12-012

4. Using the wrench, turn the track tensioner until the track has significant slack.



Figure 12-26

12-013

5. Remove the nut from the bolt that fastens the track tensioner to the drive sprocket assembly.

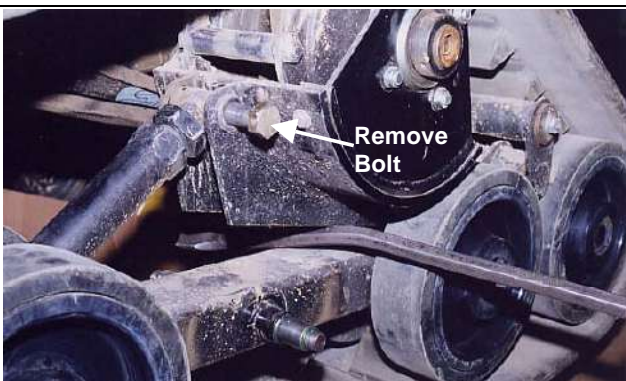

Figure 12-27

12-014

6. Using a crowbar, pry up the drive sprocket assembly until the track tensioner bolt is loose. Remove the bolt.

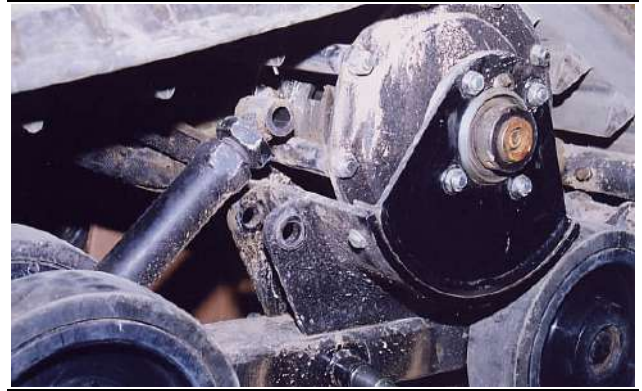

Figure 12-28

12-015

7. Pry the drive sprocket assembly away from the tensioner and pivot the tensioner out of the way. Lower the drive sprocket assembly until it is resting on the rail.



Figure 12-29

12-056

8. With the wheels removed and the drive sprocket lowered, the track is ready for removal.



Figure 12-30

12-017

9. Pull the track to the outside, and remove the track.



## Track Installation

### ! WARNING !

To install the tracks, the machine must be jacked up and placed on jack stands sturdy enough to support the weight of the machine. The manufacturer-supplied jack stands are recommended.



Figure 12-31

12-047

1. Place the track around the back wheels and on top of the drive sprocket. Make sure the track drive lugs mesh with the sprocket.



Figure 12-32

12-048

2. Using soap, lubricate the front inside wheel. Pull the track past the outside wheel shaft and onto the front inside wheel. The soap will help the track slide onto the wheel.



Figure 12-33

12-049

3. Install the front wheel. Refer to *Chapter 12. Wheel Installation.*

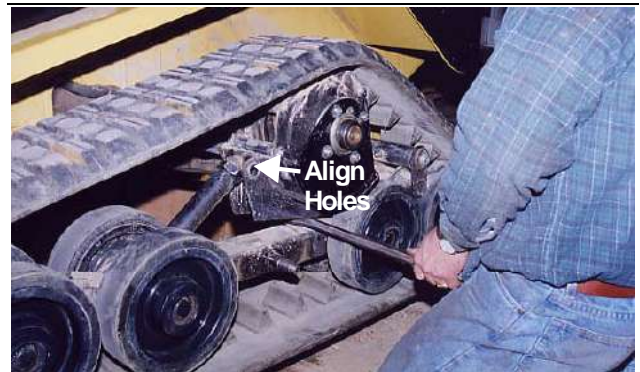

Figure 12-34

12-052

4. Pry the sprocket up until the holes in the track tensioner and drive sprocket are aligned. A floor jack or a second pry bar may be needed to get the drive table off the rail.

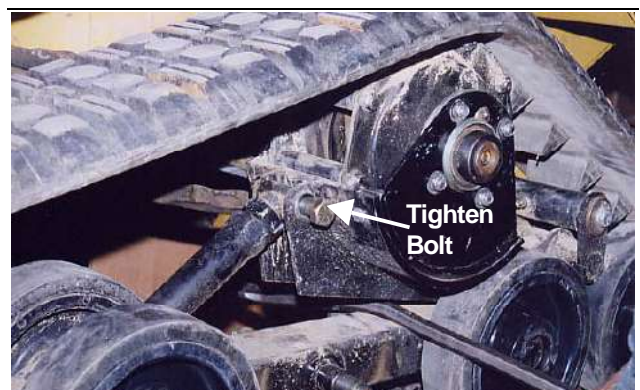

Figure 12-35

12-053

5. Install and tighten the track tensioner bolt and nut.



**12. Undercarriage Disassembly and Assembly**



Figure 12-36

12-054

6. Install the remaining wheels making sure the wheel nuts, o-rings, wheel caps, and snap-rings are properly installed. Refer to *Chapter 12. Wheel Installation.*

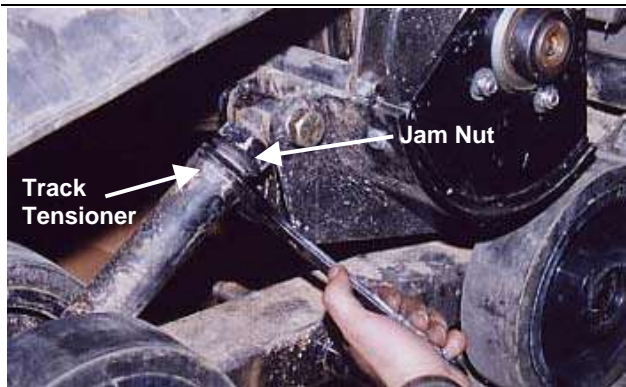

Figure 12-37

12-055

7. Tighten the track by turning the track tensioner. When proper track tension has been achieved, tighten the jam nut on the track tensioner.
8. Check for proper track tension. Refer to *Chapter 16. Maintenance – Checking for Proper Track Adjustment*

**Sprocket Bearing Plate Removal and Installation**

The tools required for sprocket bearing plate removal and installation are listed in Table 12-5. Use manufacturer-recommended tools whenever possible.

Table 12-5

Required Tools	
Socket Wrench	Allen Wrench
Combination Wrench	Torque Wrench
Steel Punch	

**Sprocket Bearing Plate Removal**

1. Remove the track. Refer to *Chapter 12. Track Removal.*
2. Move the brake away from the sprocket. Refer to the *Chapter 12. Brake Removal.*



Figure 12-38

12-023

3. Remove the bolt on the left that secures the bearing plate to the drive table.



Figure 12-39

12-024

4. Remove the bolt on the right that secures the bearing plate to the drive table.

## 12. Undercarriage Disassembly and Assembly



Figure 12-40

12-025

5. Loosen the allen bolt from the lock collar. Using a steel punch, rotate the lock collar in the direction opposite to which it was tightened. (You will be able to see the original marks on the collar.) Use the punch hole to rotate. **DO NOT** chisel against the allen bolt or use the allen bolt hole to rotate the collar. Remove the lock collar



Figure 12-41

12-026

6. Pry the bearing plate off the shaft. Be careful not to bend or damage the bearing plate or bearing flange.



Figure 12-42

12-027

7. Remove the bearing plate from the sprocket shaft.



Figure 12-43

12-028

8. Remove the bearing flange bolts from the bearing plate.



Figure 12-44

12-029

9. Split the bearing flanges and expose the bearing. Replace if necessary.



### Sprocket Bearing Plate Installation



Figure 12-45

12-028

1. If the bearing flanges were split to inspect the bearing or install a new bearing, place the flanges together. Attach the flanges to the bearing plate with the four flange bolts.

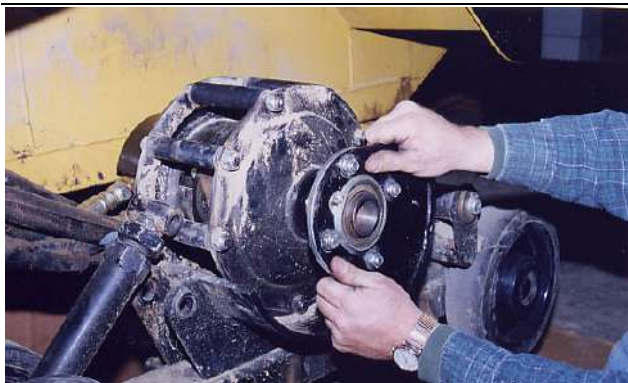

Figure 12-46

12-039

2. Slide the bearing plate onto the shaft.



Figure 12-47

12-040

3. Install and tighten the two bolts that fasten the bearing plate to the drive table.



Figure 12-48

12-041

4. Slide the lock collar all the way onto the shaft until it stops. Rotate the lock collar in the direction opposite to which it was loosened. Using a punch in the punch hole, tighten the collar. Tighten the allen bolt.

### Sprocket Removal and Installation

The tools required for sprocket removal and installation are listed in Table 12-6. Use manufacturer-recommended tools whenever possible.

Table 12-6

Required Tools	
Socket Wrench	Impact Driver
Sprocket Puller	

### Sprocket Removal



Figure 12-49

12-030



## 12. Undercarriage Disassembly and Assembly

1. Remove the bearing plate as described above. Remove the bolt from the center of the sprocket shaft.



Figure 12-50

12-031

2. Insert the sprocket puller into the hole from which the bolt was removed.



Figure 12-51

12-032

3. Using a large impact driver, tighten the sprocket puller until the sprocket breaks free. If the puller stops tightening before freeing the sprocket, hit the end of the puller a few times with a hammer. Then retighten with the impact driver. Once the sprocket breaks free, remove the puller. Adding some heat to the shaft can aid removal.



Figure 12-52

12-033

4. Remove the sprocket. Be careful not to lose the key that fits into the drive motor shaft.

### Sprocket Installation



Figure 12-53

12-042

1. After inspecting and cleaning the shaft, spray 7471 Loctite Primer on to the shaft.



Figure 12-54

12-043

2. Once the primer has dried spread 680 Loctite Retaining Compound onto the shaft. The retain-

**12. Undercarriage Disassembly and Assembly**

ing compound is very important; it fills in small inconsistencies in the shaft and creates a better bond between the shaft and the sprocket..

Required Tools
Socket Wrench
Crows Foot Attachment



Figure 12-55

12-034

- Align the key on the shaft with the key-way in the drive sprocket, then slide the sprocket onto the shaft. Install the bolt into the end of the sprocket shaft and finger tighten. Complete the next two steps as soon as possible to prevent the Loctite from drying before the sprocket is tightened.



Figure 12-55b

12-034b

Using a torque wrench, tighten the sprocket bolt to 85 lb-ft.

- Reinstall the bearing plate.

## Drive Motor Removal and Installation

Use manufacturer-recommended tools whenever possible.

### Drive Motor Removal



Figure 12-56

12-035

- Using a pressure washer or compressed air, clean all hydraulic fittings on the drive motor thoroughly before removing any hoses. Dry the fittings. Remove the hoses and cap immediately.



Figure 12-57

12-036

- Using a pressure washer or compressed air, clean the case drain fitting thoroughly before removing the hose. Dry the fitting. Remove the hose and cap immediately.





Figure 12-57b

12-037b

## Drive Motor Installation

1. Position the drive motor so the hydraulic fittings exit in the correct location. Install the drive motor bolts. Clean and inspect the drive motor shaft.
  2. Reinstall all hoses and fittings.
  3. Reinstall drive sprocket as outlined above.
- 

3. Remove the bolts that fasten the drive motor to the drive table. Three of the four bolts can be removed using conventional tools.



Figure 12-58

12-037

4. Using a "crows foot" attachment, remove the fourth bolt that fastens the drive motor to the drive table.



Figure 12-59

12-038

5. Remove the drive motor by rotating, or indexing it until it fits through the opening. Once out, cap all hydraulic fittings on the drive motor.



# 13. Loader Disassembly and Assembly

## Chapter Overview

This chapter provides disassembly and assembly procedures for the loader assembly.

## Personal Safety

**! WARNING !**

Improper operation, lubrication, maintenance or repair of this product can be dangerous and could result in injury or death.

Do not operate or perform any lubrication, maintenance or repair on this product until you have read and understood the operation, lubrication, maintenance and repair information.

Before starting any disassembly or assembly procedures, refer to *Chapter 2. Product Safety – Basic Precautions* for personal safety information.

## Machine Preparation

**! WARNING !**

Accidental machine starting can cause injury or death to personnel working on the machine.

To avoid accidental machine starting, disconnect the battery cables from the battery and tape the battery clamps and remove the key.

Place a “Do Not Operate” tag prominently on the machine to inform personnel that the machine is being worked on.

Before starting any disassembly or assembly procedures, refer to *Chapter 2. Product Safety – Repair* for machine preparation information.

## Preliminary Checkout

If troubleshooting is required prior to disassembly or assembly, refer to *Chapter 15. Troubleshooting*.

## Loader Disassembly and Assembly Procedures

Disassembly and assembly procedures are provided for the following loader components.

- Lift Cylinders
- Tilt Cylinders
- Pressure Release Valve

**Note:** Procedures are provided for only those loader components listed above. However, information for removal and installation of other loader components can be obtained from the Rubber Track Loader Parts List manual.

## Lift Cylinder/Tilt Cylinder Removal and Installation

The tools required for lift cylinder removal and installation are listed in Table 13-1. Use manufacturer-recommended tools whenever possible.

Table 13-1

Required Tools
Combination Wrench
Socket Wrench

## Lift Cylinder/Tilt Cylinder Removal

**Note:** Since the procedures for removing the lift cylinders and tilt cylinders are identical, only the lift cylinder procedure is described below.

**! WARNING !**

Hot oil can cause personal injury. Lower all attachments and make sure the oil is cool before removing any components or lines.

Remove the oil filler cap only when the engine is stopped and the filler cap is cool enough to touch with your hands.

### NOTICE

Collect and contain liquids in a suitable container. Dispose of all liquids according to local regulations and mandates.

### 13. Loader Disassembly and Assembly

**Note:** During disassembly, cap all hoses and fittings to prevent fluid loss and contamination of the system fluids.

1. Lower the loader arms onto a jackstand with the arms resting about 6 inches off the ground.
2. Turn the engine start switch to the OFF position.

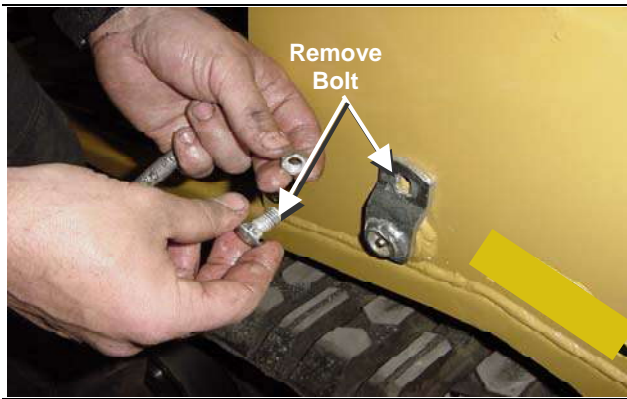

Figure 13-1

13-001

3. Remove the bolt on the pin assembly on the loader tower.



Figure 13-2

13-002

4. Remove the pin assembly.

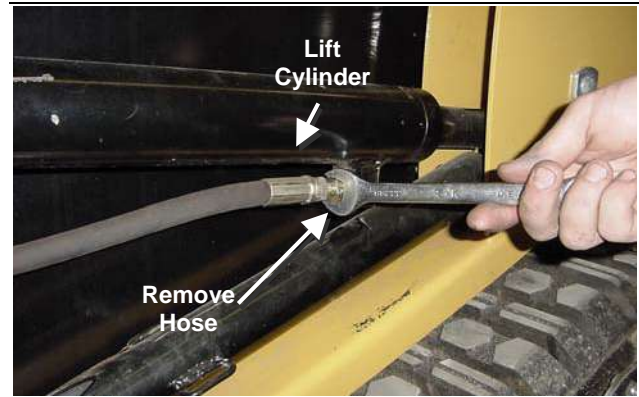

Figure 13-3

13-003

5. Remove and cap the hose on the ram end of the cylinder.

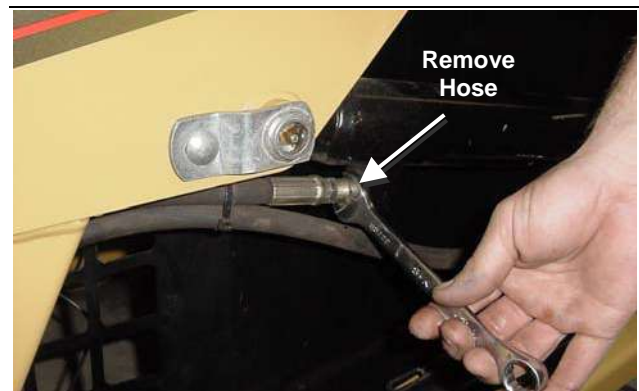

Figure 13-4

13-004

6. Remove and cap the hose on the loader end of the cylinder.



Figure 13-5

13-005

7. Remove the forward pin assembly bolt.

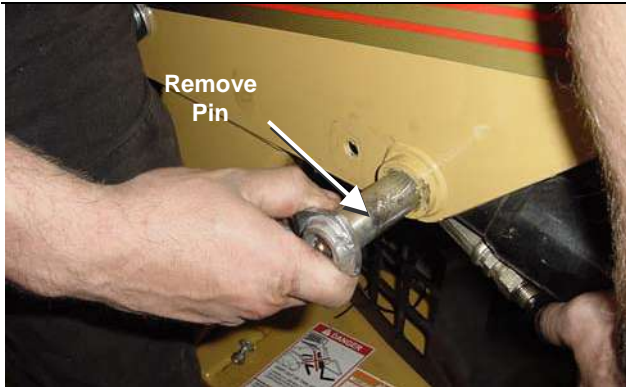

Figure 13-6

13-006

8. Remove the forward pin assembly.



Figure 13-7

13-007

9. Remove the lift cylinder from the machine.

### Lift Cylinder/Tilt Cylinder Installation

**Note:** Reverse the above steps to install the cylinder.

**Note:** Begin the lift cylinder installation with the loader arms lowered and resting about 6 inches off the ground on a jackstand. This is the position the loader arms were in following lift cylinder removal.

## Quick-Coupler Block / Pressure Release Valve Removal and Installation

The tools required for low-flow relief valve removal and installation are listed in Table 13-2. Use manufacturer-recommended tools whenever possible.

Table 13-2

Required Tools
Combination Wrench
Socket Wrench

### Pressure Release Valve Removal

**! WARNING !**

Hot oil can cause personal injury. Lower all attachments and make sure the oil is cool before removing any components or lines.

### NOTICE

Collect and contain liquids in a suitable container. Dispose of all liquids according to local regulations and mandates.

**Note:** During disassembly, cap all hoses and fittings to prevent fluid loss and contamination of the system fluids.

1. Lower the lift arms to the ground.
2. Turn the engine start switch to the OFF position.





Figure 13-8 13-008

3. Press the button on top of the valve to release hydraulic pressure.

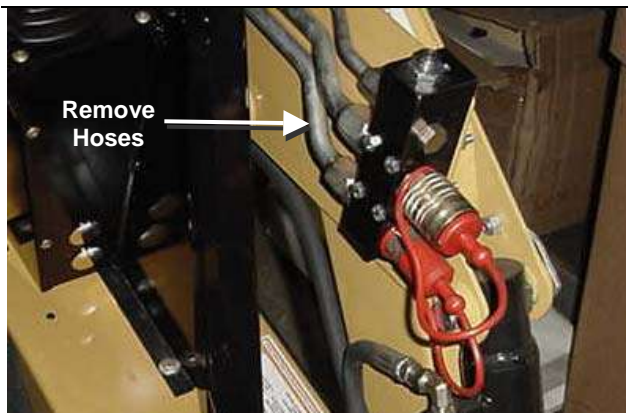

Figure 13-9 13-009

4. Remove and cap all hoses.

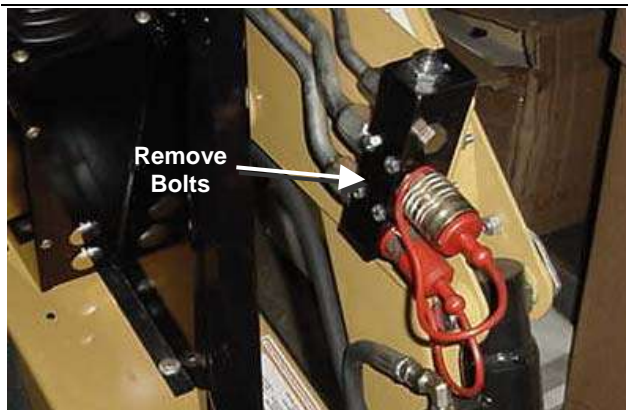

Figure 13-10 13-009

5. Remove the four bolts that secure the low-flow relief valve to the loader frame and remove the valve.

### Quick Coupler Block / Pressure Release Valve Installation

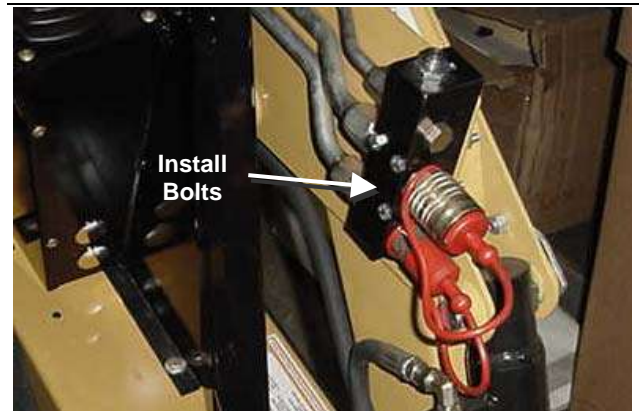

Figure 13-11 13-009

1. Install the four bolts that secure the low-flow relief valve to the loader frame.

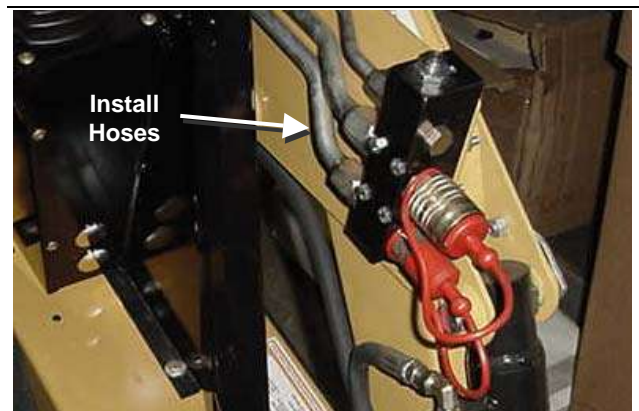

Figure 13-12 13-009

2. Install all hoses.

# 14. Quick Attach Disassembly and Assembly

## Chapter Overview

This chapter provides disassembly and assembly procedures for the quick attach assembly.

## Personal Safety

### ! WARNING !

Improper operation, lubrication, maintenance or repair of this product can be dangerous and could result in injury or death.

Do not operate or perform any lubrication, maintenance or repair on this product until you have read and understood the operation, lubrication, maintenance and repair information.

Before starting any disassembly or assembly procedures, refer to *Chapter 2. Product Safety – Basic Precautions* for personal safety information.

## Machine Preparation

### ! WARNING !

Accidental machine starting can cause injury or death to personnel working on the machine.

To avoid accidental machine starting, disconnect the battery cables from the battery and tape the battery clamps and remove the key.

Place a “Do Not Operate” tag prominently on the machine to inform personnel that the machine is being worked on.

Before starting any disassembly or assembly procedures, refer to *Chapter 2. Product Safety – Repair* for machine preparation information.

## Preliminary Checkout

If troubleshooting is required prior to disassembly or assembly, refer to *Chapter 15. Troubleshooting*.

## Quick Attach Disassembly and Assembly Procedures

Disassembly and assembly procedures are provided for the following quick attach components.

- Latch Pin Assembly
- Quick Attach Assembly

**Note:** Procedures are provided for only those quick attach components listed above. However, information for removal and installation of other quick attach components can be obtained from the Rubber Track Loader Parts List manual.

## Latch Pin Assembly Removal and Installation

The tools required for latch pin removal and installation are listed in Table 14-1. Use manufacturer-recommended tools whenever possible.

Table 14-1

Required Tools
Steel Punch
Hammer
Pliers

## Latch Pin Assembly Removal

1. With no work tool attached and suitable blocks in place, tilt the quick attach assembly forward and lower the lift arms until the quick attach assembly rests securely on the blocks about 6 inches off the ground.
2. Turn the engine start switch to the OFF position.

**14. Quick Attach Disassembly and Assembly**

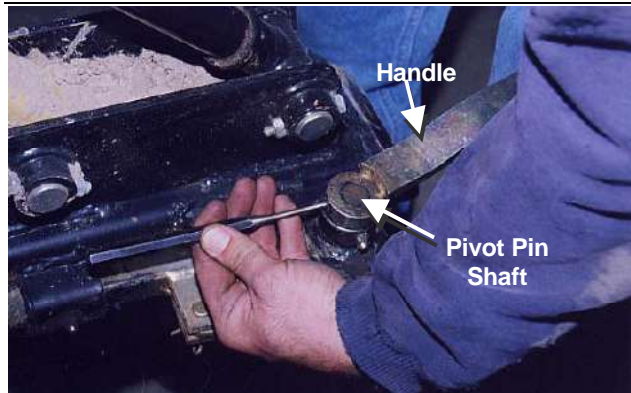

Figure 14-1

14-001

3. With a steel punch, remove the spring pin that fastens the handle to the pivot pin shaft. Slide the handle off the shaft.

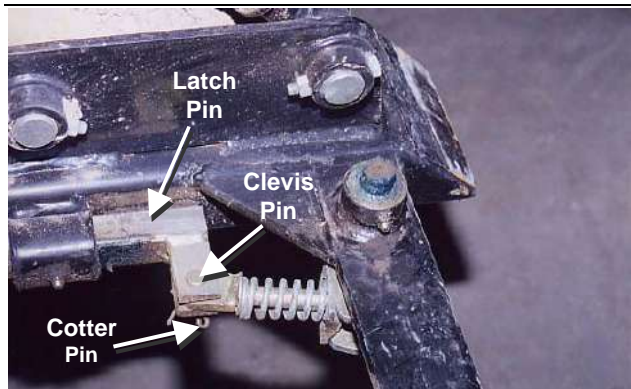

Figure 14-2

14-002

4. Remove the cotter pin. Pull out the clevis pin that fastens the latch pin to the spring mechanism.

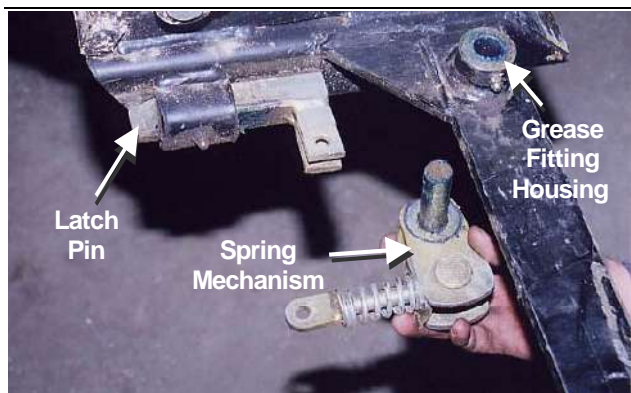

Figure 14-3

14-003

5. Remove the spring mechanism from the grease fitting housing. Remove the latch pin from the quick attach bracket

**Latch Pin Assembly Installation**

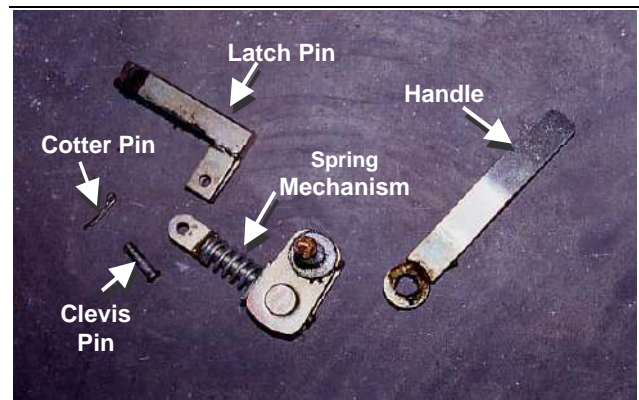

Figure 14-4

14-004

1. The quick attach parts are individually replaceable.
2. With no work tool attached and suitable blocks in place, tilt the quick attach assembly forward and lower the lift arms until the quick attach assembly rests securely on the blocks about 6 inches off the ground.
3. Turn the engine start switch to the OFF position.

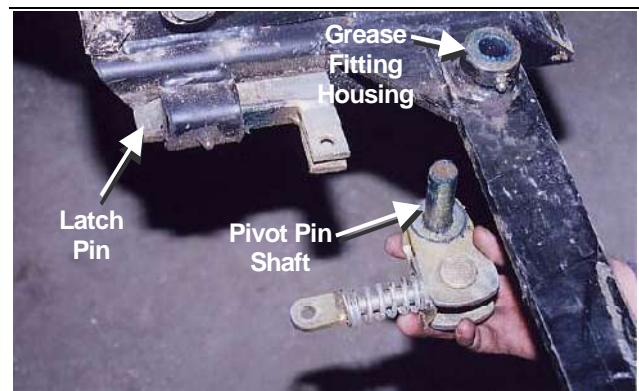

Figure 14-5

14-003

4. Slide the latch pin into the quick attach bracket and insert the pivot pin shaft in the grease fitting housing.



**14. Quick Attach Disassembly and Assembly**

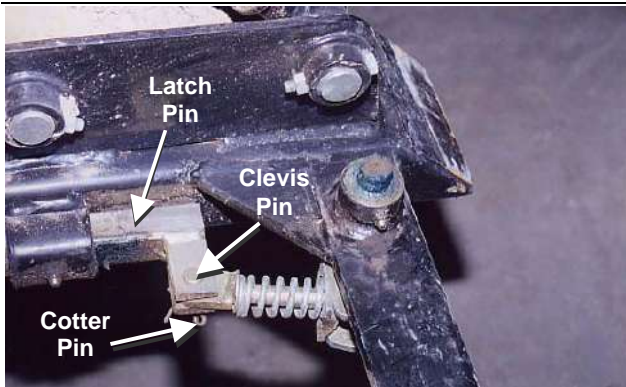

Figure 14-6 14-002

5. Insert the clevis pin that fastens the latch pin to the spring mechanism. Install the cotter pin.

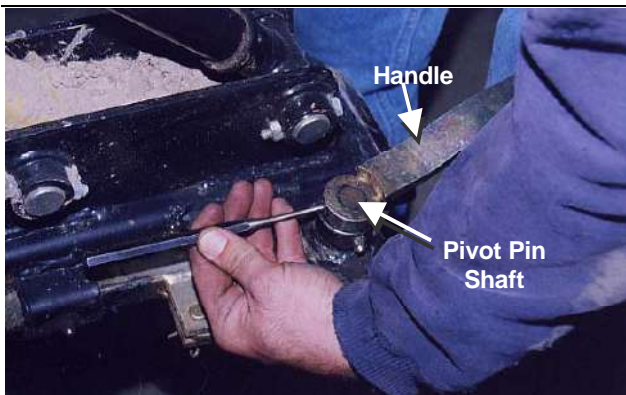

Figure 14-7 14-001

6. Slide the handle onto the pivot pin shaft. Insert the spring pin that fastens the handle to the pivot pin shaft.

**Quick Attach Assembly Removal and Installation**

The tools required for quick attach assembly removal and installation are listed in Table 14-2. Use manufacturer-recommended tools whenever possible.

Table 14-2

Required Tools
Combination Wrench

**Quick Attach Assembly Removal**

1. With no work tool attached and suitable blocks in place, tilt the quick attach assembly forward and lower the lift arms until the quick attach assembly rests securely on the blocks about 6 inches off the ground.
2. Turn the engine start switch to the OFF position.

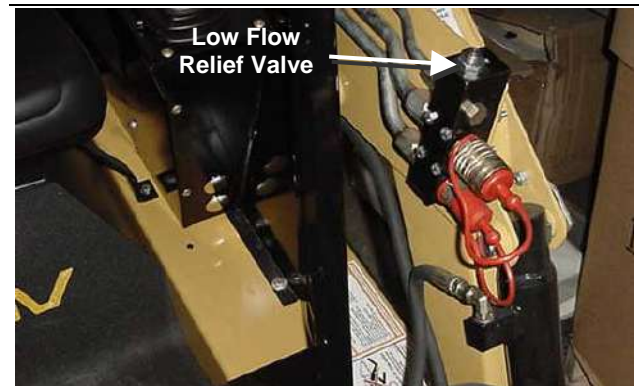

Figure 14-8 14-005

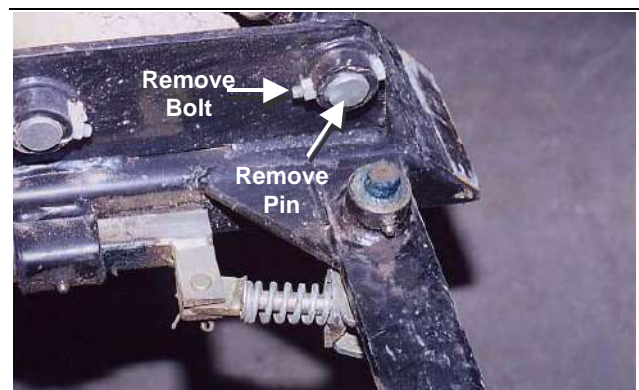

Figure 14-9 14-002

3. Remove the bolt and push out the pin that secures each end of the quick attach assembly to the tilt cylinders.

## 14. Quick Attach Disassembly and Assembly

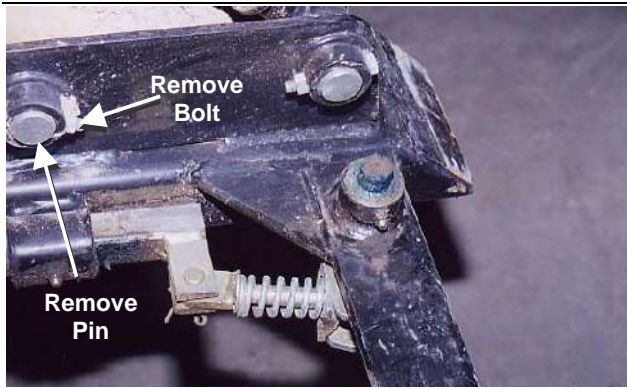

Figure 14-10

14-002

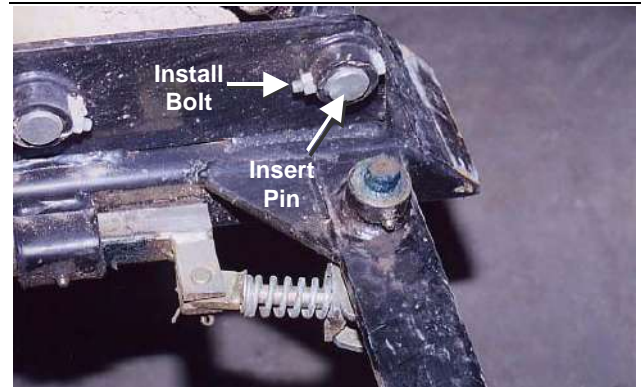

Figure 14-12

14-002

4. Remove the bolt and push out the pin that secures each end of the quick attach assembly to the loader frame.
5. The quick attach assembly is now free and ready to be moved by a forklift.

3. Insert the pin and install the bolt that secures each end of the quick attach assembly to the tilt cylinders.

### Quick Attach Assembly Installation

1. With a forklift, move the quick attach assembly in position to be secured to the loader frame and tilt cylinders.

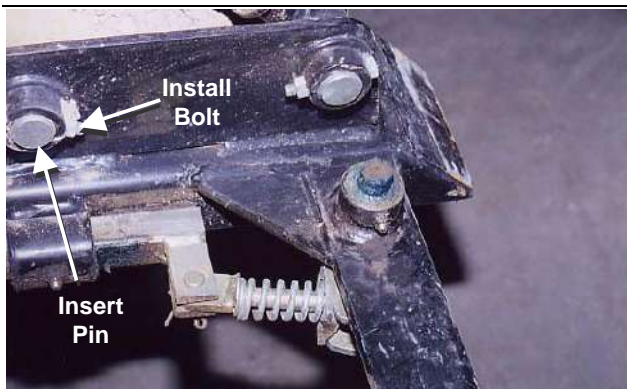

Figure 14-11

14-002

2. Insert the pin and install the bolt that secures each end of the quick attach assembly to the loader frame.

# 15. Troubleshooting

## Chapter Overview

This chapter contains basic troubleshooting procedures for the Rubber Track Loader.

Additional troubleshooting aids are provided in *Chapter 3. System Diagrams* and in those chapters containing disassembly and assembly procedures for the appropriate component or assembly.

## Personal Safety

### ! WARNING !

**Improper operation, lubrication, maintenance or repair of this product can be dangerous and could result in injury or death.**

**Do not operate or perform any lubrication, maintenance or repair on this product until you have read and understood the operation, lubrication, maintenance and repair information.**

Before starting any troubleshooting procedures, refer to *Chapter 2. Product Safety – Basic Precautions* for personal safety information.

## Machine Preparation

### ! WARNING !

**Accidental machine starting can cause injury or death to personnel working on the machine.**

**To avoid accidental machine starting, disconnect the battery cables from the battery and tape the battery clamps and remove the key.**

**Place a “Do Not Operate” tag prominently on the machine to inform personnel that the machine is being worked on.**

Before starting any troubleshooting procedures, refer to *Chapter 2. Product Safety – Repair* for machine preparation information.

## Preliminary Checkout

A simple visual inspection and operational check can identify many problems without the need for extensive troubleshooting. If these checks indicate a problem that requires further analysis, proceed to *Troubleshooting* in this section.

## Visual Inspection

Prior to troubleshooting, do a walk-around and perform a visual inspection of the machine. Look for missing, loose or worn parts. Perform the following visual checks.

- Track tension
- Fluid levels
- Fan belt tension and condition
- Hoses (no visible sign of wear)
- Fittings (no leaks)
- Battery cables
- Fuse box (fuses in place and operational)
- Controls (for neutral)



## Troubleshooting

This section identifies selected problems and suggests probable causes.

### **Problem 1**

Machine will not crank over.

#### **Probable cause**

1. Weak or dead battery.
2. Battery cables loose or corroded.
3. Ignition fuse blown.
4. Main starter fuse blown.
5. Starter relay malfunctioning.
6. Bad ignition switch.
7. Bad starter.
8. Poor wire connections at key, relay, or starter.

### **Problem 2**

Machine cranks but will not start.

#### **Probable cause**

1. Auxiliary hydraulic direction switch is activated sending oil over relief valve. (Will see black smoke.)
2. Injection pump fuse blown.
3. Main power fuse B blown.
4. Main power relay B not activating.
5. Poor wire connection at injection pump or fuse.
6. Glow plugs not heating. (Will see black smoke.)
  - a) Main glow plug fuse blown.
  - b) Glow plug relay not activating.
  - c) Poor wire connections at ignition switch, relay, or glow plug strip.
  - d) Failed glow plugs.
  - e) Bad ignition switch.

### **Problem 3**

Machine starts but hydraulics will not operate.

#### **Probable cause**

1. Lap bar must be in down position, operator must be seated in seat, and front door (if installed) must be closed.
2. Safety fuse blown.
3. Faulty operator presence switch.
  - a) Test continuity through seat, lap bar, and door switch. Adjust or replace as necessary. Lap bar and door switch are magnetic switches and should be adjusted to approximately 1/16 inch away from steel pickup bracket.
4. Poor ground (check ground wires on bottom left rear side of hydraulic reservoir).
5. Safety relay is not activating.
6. Faulty safety solenoid or safety solenoid spool.

7. Poor wire connections on fuse, relay, or safety solenoid.
8. Low charge pressure.

### **Problem 4**

Loader operates but tracks will not move.

#### **Probable cause**

1. Leak in feed line to pilot control.
2. Pilot control malfunctioning.

### **Problem 5**

Tracks operate but loader will not operate.

#### **Probable cause**

1. Auxiliary direction switch activated sending oil over relief.
2. Check to see if auxiliary flow works. (If auxiliary flow works, skip to number 5).
3. Main auxiliary relief malfunction.
4. Auxiliary pump bad.
5. Leak in feed line to loader control pilot.
6. Loader control pilot malfunctioning.

### **Problem 6**

Auxiliary flow does not work. Loader works.

#### **Probable cause**

1. Auxiliary mode switch in opposing position.
  - a) Auxiliary mode switch in part-time position operates yellow thumb switch.
  - b) Auxiliary mode switch in full-time position operates direction switch on right hand dash.
2. Auxiliary hydraulic fuse blown.
3. Faulty ground wire.
  - a) Clean ground connections on left rear side of hydraulic tank.
4. Auxiliary hydraulic direction switch failure.
5. Poor wire connections at fuse, direction switch, or pin connector P17.
6. Auxiliary hydraulic pilot generation spool stuck.
7. Bad or not fully connected Quick-Coupler

### **Problem 7**

Auxiliary hydraulic part-time thumb switch operates but full-time flow direction switch will not operate.

#### **Probable cause**

1. Auxiliary hydraulic mode switch in wrong position or faulty.
2. Auxiliary direction switch faulty.
3. Poor wire connections at mode switch or direction switch.

### **Problem 8**

Auxiliary hydraulic full-time direction switch operates but part-time thumb switch will not operate.

#### **Probable cause**

1. Auxiliary hydraulic mode switch in wrong position or faulty.
2. Auxiliary hydraulic thumb switch malfunction.
3. Poor wire connections at direction switch, thumb switch, or pin connector P17.

### **Problem 9**

Auxiliary hydraulics will only flow one way.

#### **Probable cause**

1. Auxiliary hydraulic relay 1 or 2 failure.
2. Auxiliary hydraulic pilot generation coil faulty.
3. Auxiliary hydraulic pilot generation spool faulty.
4. Poor wire connections at relay, pilot generation solenoid, pin connector P16 or P21.
5. Loader valve malfunction.

### **Problem 10**

No power to numerous auxiliary functions or accessories in ON or RUN position.

#### **Probable cause**

1. Main power relay A or B fuse blown.
2. Main relay A or B faulty.
3. Ignition switch malfunction.
4. Poor wire connections at ignition switch, fuse, or relay.

### **Problem 11**

Battery will not charge and/or battery goes dead.

#### **Probable cause**

1. Alternator fuse blown.
2. Alternator diode bad.
3. Poor wire connections at battery, alternator, diode, or fuse.
4. Excessive draw in off position.
  - a) Fuel gauge and hour meter should draw only 0.01 amps in off position.
5. Bad battery.
6. Bad alternator.

### **Problem 12**

Loader control will not lock in float position.

#### **Probable cause**

1. Float magnet fuse blown.
2. Poor wire connections at fuse, float detent magnet, or pin connector P18.
3. Faulty float detent magnet.

### **Problem 13**

Loader will not float; labors engine and has down pressure when detented into float.

#### **Probable cause**

1. Engine RPM too low.
  - a) Float must be operated at a minimum of half throttle.
2. Low charge pressure.
3. Pilot control malfunction.
4. Loader valve malfunction.

### **Problem 14**

Hot oil light illuminates; hydraulic system operating hot.

#### **Probable cause**

1. Auxiliary hydraulic switch activated sending oil over relief.
2. Low oil level.
3. Debris plugging oil cooler limiting airflow.
4. Broken fan blades.
5. Loose fan belt.
6. Improper attachment.
  - a) Attachment must be rated at a minimum of 10 gallons per minute and 3000 PSI.
  - b) Attachment hose size must be a minimum of 3/8 inch.
7. Faulty hot oil sending unit.
  - a) Hot oil light should illuminate at 225°F.
8. Faulty quick coupler.
9. Cooler bypass relief.
  - a) Cooler bypass relief should open at 100 PSI.

### **Problem 15**

Track makes popping noise.

#### **Probable cause**

1. Track too loose. (Refer to track adjustment section.)
2. Worn or stuck drive teeth. Outer roller should pivot as lug comes into sprocket.
3. Loose or worn sprocket.
4. Worn track lugs.





# 16. Maintenance

## Chapter Overview

This chapter contains maintenance requirements and procedures for the following All Surface Loader components.

- Engine oil
- Hydraulic fluid and filter
- Fuel filter
- Track tension
- Air cleaner
- Fuse box
- Grease fittings

## Maintenance Schedule

Maintenance schedule is listed in Table 16-1.

Table 16-1

Item	Frequency	Lubricant	Capacity
Hydraulic Fluid	500 hrs	<b>ASV Posi-Lube Hydraulic Oil</b> , or Rykon MV	8 gal/30 l
Hydraulic Filter	250 hrs		
Engine Oil	250 hrs	<b>Posi-Lube HD Diesel Engine Oil</b> , or other	4 qt/3.79 l
Engine Filter	250 hrs		
Fuel Filter	500 hrs		
Primary Air Filter	Check daily, clean and reuse as needed up to 5 times; change at least once per year		
Secondary Air Filter	Every 3 cleanings of primary filter		
Grease Fittings	10 hrs	<b>Posi-Lube Lithium Grease</b>	
Track Tension	As needed		

### NOTICE

When replacing engine coolant, use **Posi-Lube Long Life 50/50 Antifreeze/Coolant**, Caterpillar Extended Life Coolant or equivalent antifreeze with the proper SCA (Supplemental Cooling Additive)

## Engine Oil

The normal oil change interval is every 250 service hours or six months, whichever comes first. Engines that are operated under severe conditions may need the oil changed every 100 service hours or every 3 months, whichever comes first. Severe operating conditions include: high temperatures, continuous high loads and dusty conditions.

## Oil Change Procedures

1. Run the engine for a few minutes to warm the engine oil.

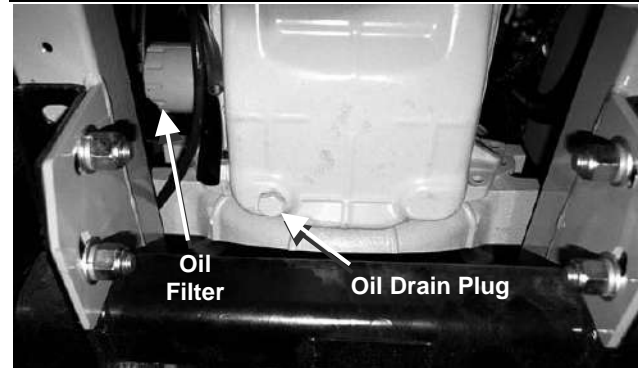

Figure 16-1

16-001

2. Remove drain plug from bottom of the engine.
3. Drain oil into suitable container.
4. Remove engine oil filter, making sure the gasket is also removed.
5. Put some fresh oil on the new filter gasket and install new filter.
6. Tighten filter to specifications on filter label.
7. Refill engine to capacity with oil, as specified.

## Engine Oil Specifications

Due to the variations in the quality and performance of commercially available oils, **ASV Posi-Lube Heavy Duty Diesel Engine Oil – 10W30** is recommended. If Posi-Lube is not available, use one of the following:

- Caterpillar Diesel Engine Oil – 10W30 (-4°F to 104°F)
- Caterpillar Diesel Engine Oil – 15W40 (5°F to 122°F)

Only use commercial oils that meet the following classifications:

- EMA LRG-1 multigrade oil
- API CH-4 multigrade oil
- API CG-4 multigrade oil
- API CF-4 multigrade oil

## Hydraulic Fluid and Filter

The hydraulic fluid should be changed every 500 service hours, and the hydraulic filter should be changed every 250 hours. Hydrostatic components require extremely clean oil for long service life.

### Hydraulic Fluid and Filter Change Procedures

#### ! WARNING !

Hot oil can cause personal injury. Make sure the oil is cool before removing any components or lines.

Remove the oil filler cap only when the engine is stopped and the filler cap is cool enough to touch with your bare hand.

#### NOTICE

Extreme care must be taken when changing the hydraulic fluid. Before starting the procedure, make sure the machine is in a clean working environment. Precautions should be taken to prevent any debris from entering the hydrostatic system.

#### NOTICE

Collect and contain liquids in a suitable container. Dispose of all liquids according to local regulations and mandates.

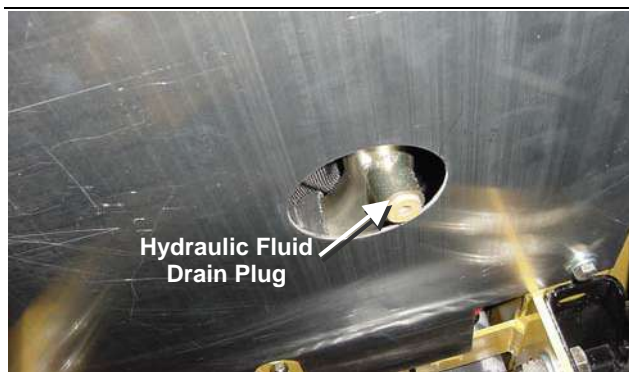

Figure 16-2

16-002

1. Locate and remove the hydraulic fluid drain plug and drain the fluid into a suitable container.

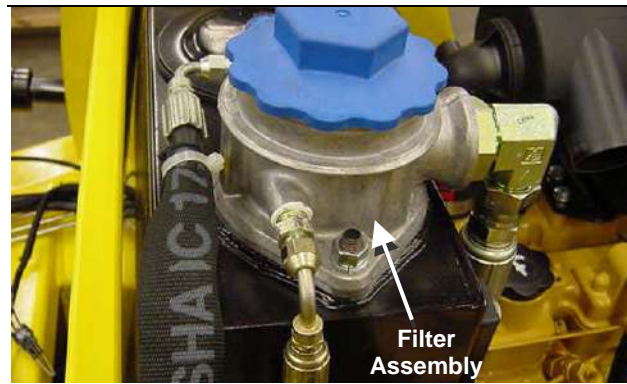

Figure 16-3

16-015

2. Clean the area around the filter assembly, which is located on the top of the hydraulic reservoir.



Figure 16-4

16-003

3. Turn the hydraulic filter counter clockwise and remove the filter
4. Change the filter element and replace the filter in the tank.
5. Fill with manufacturer-approved hydraulic fluid.

## Fuel Filter

The fuel filter should be changed every 500 service hours, or as needed. A plugged fuel filter can cause loss of engine power, rough running, or no start.

#### NOTICE

Collect and contain liquids in a suitable container. Dispose of all liquids according to local regulations and mandates.

## Fuel Filter Change Procedures



Figure 16-5

16-004

1. Clean the outside of the filter thoroughly.
2. Remove the spin-on filter and dispose of properly.
3. Pour diesel fuel into the new filter until it is full.
4. Spin the new filter into place and tighten.

## Fuel Specifications

In North America, diesel fuel distilled from crude oil and identified as NO. 1-D or No. 2-D in "ASTM D975" generally meets the proper specifications.

## Air Cleaner

The air cleaner is one of the most important maintenance items on the machine. A poorly maintained air cleaner can seriously shorten the life of the engine.

## Air Filter Change Procedures

### NOTICE

When working in dusty conditions, the air cleaner elements should be checked and changed more frequently than when working under normal conditions.

### NOTICE

Do not clean the primary air cleaner element by bumping and tapping. This could damage the seals. Do not use elements with damaged pleat gaskets or seals.

1. Open the hood, release the latches on either side of the air cleaner, and then remove the cover.



Figure 16-6

16-010

2. Remove the primary element. The primary element can be cleaned and reused up to five times, but it should be changed at least once a year.



Figure 16-7

16-011

3. Remove the safety element. The safety element is not serviceable or washable. It should be replaced with every three cleanings of the primary element.

## Track Tension

Proper track tension is very important for optimum performance and long track life. Tracks that are run too loose can cause misfeeding and ratcheting possibly causing damage to the track. During the first 50 hours of operation, the tracks will "break in" and will most likely require adjustment.



## Track Tension Adjustment Procedures

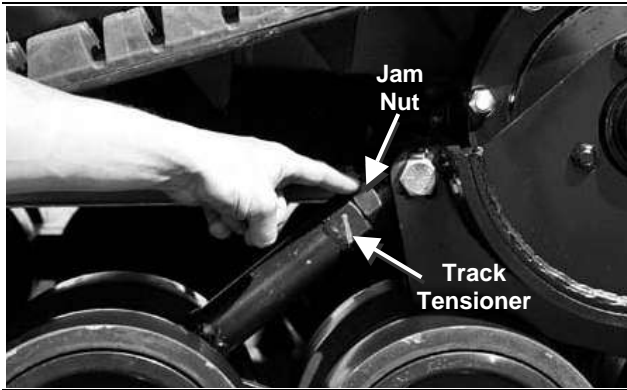

Figure 16-8

16-005

1. Locate the jam nut on the track tensioner and clean the threads thoroughly before proceeding.



Figure 16-9

16-006

2. Loosen the jam nut. You can use the wrench supplied with the machine, but a standard wrench is preferred for shop use.



Figure 16-10

16-007

3. After loosening the jam nut, turn the track tensioner until the track tension is within specifications.
4. Once proper tension is achieved, retighten the jam nut

## Checking for Proper Track Adjustment

1. Drive the machine forward five feet.



Figure 16-11

16-008

2. Lay a straightedge along the top of the track between the sprocket and the front idler wheel.
3. Using a rope or wire, put 50 pounds of down force on the track at the midpoint of the straightedge.



Figure 16-12

16-009

4. Using a ruler, measure the distance between the straightedge and track. The track should not deflect more than 0.75 inch between the top of the track and the straightedge.
5. If the track deflects more than 0.75 inch, tighten the track.

## Fuse Box



Figure 16-13

16-012

The fuse box is located on the left side of the engine compartment. The machine should never be operated with the fuse box cover removed.

## Grease Fittings

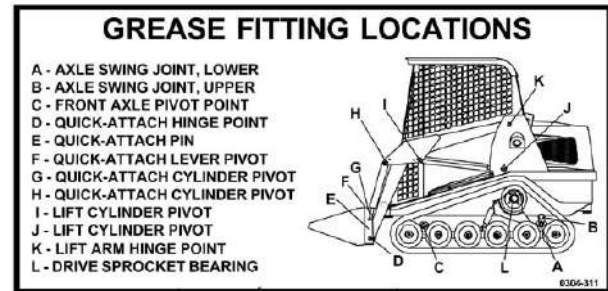

Figure 16-14

16-013

The locations of the grease fittings for the left side of the machine are shown above. An identical set of fittings is located on the right side of the machine. These fittings should be lubricated at least after every 10 hours of operation using **Posi-Lube Multi Purpose EP Lithium Grease**, or other high-quality, low-temperature grease.





# 17. Hydraulic Pressure Check & Adjustment

## Chapter Overview

This chapter provides a overview of checking and setting pressures. It is important to contact the manufacturer for assistance before beginning these procedures.

## Personal Safety

**! WARNING !**

Improper operation, lubrication, maintenance or repair of this product can be dangerous and could result in injury or death.

Do not operate or perform any lubrication, maintenance or repair on this product until you have read and understood the operation, lubrication, maintenance and repair information.

Before starting any disassembly or assembly procedures, refer to *Chapter 2. Product Safety – Basic Precautions* for personal safety information.

## Machine Preparation

**! WARNING !**

Accidental machine starting can cause injury or death to personnel working on the machine.

To avoid accidental machine starting, disconnect the battery cables from the battery and tape the battery clamps and remove the key.

Place a “Do Not Operate” tag prominently on the machine to inform personnel that the machine is being worked on.

Before starting any disassembly or assembly procedures, refer to *Chapter 2. Product Safety – Repair* for machine preparation information.

## Hydraulic Pressure Adjustment Procedures

Adjustment and test procedures are provided for the following transmission and drive components.

- Charge Pressure Check & Adjustment
- Drive-Pressure Relief Valve Adjustment
- Auxiliary Valve Pressure Check & Adjustment

## Charge Pressure Check

The service tools required for the charge pressure check are listed in Table 0-1. Use manufacturer-recommended tools whenever possible.

Table 0-1

Required Tools
Pressure Gauge
Combination Wrench
Socket Wrench

**Note:** The fuel tank SHOULD NOT be removed to perform this procedure.



Figure 0-1

10-101

1. Remove the floor pan.

17. Hydraulic Pressure Check & Adjustment

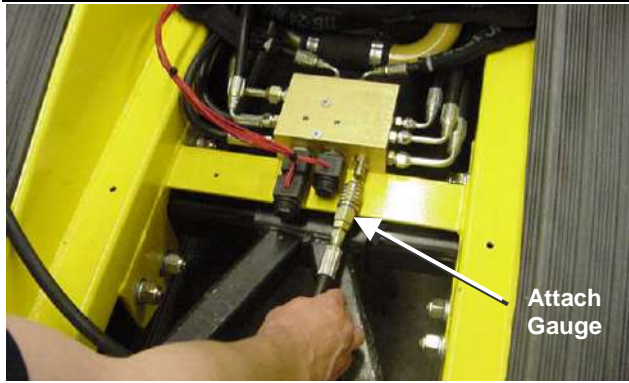

Figure 0-2

10-102

2. Attach the gauge to the pilot control manifold test port. Located under the fuel tank, you will not need to remove the fuel tank.
3. Start the engine.
4. Check the pressure with the engine at wide open throttle. Make sure the engine is properly warmed up before running wide open.
5. Turn the engine start switch to the OFF position.
6. Remove the gauge from the pilot control manifold test port.
7. Install the floor pan

**Charge Pressure Relief Valve Adjustment**

The service tools required for charge pressure relief valve adjustment are listed in Table 0-2. Use manufacturer-recommended tools whenever possible.

Table 0-2

Required Tools
Combination Wrench
Socket Wrench

**Note:** In the following procedure, some components are shown detached from the machine to facilitate the description. However, the charge pressure check is normally performed from under the machine with only the center skid plate removed.

**! WARNING !**

Hot oil can cause personal injury. Lower all attachments and make sure the oil is cool before removing any components or lines.

Remove the oil filler cap only when the engine is stopped and the filler cap is cool enough to touch with your hands.

**NOTICE**

Collect and contain liquids in a suitable container. Dispose of all liquids according to local regulations and mandates.

**Note:** During disassembly, plug all hoses and tubes to prevent fluid loss and contamination of the system fluids.

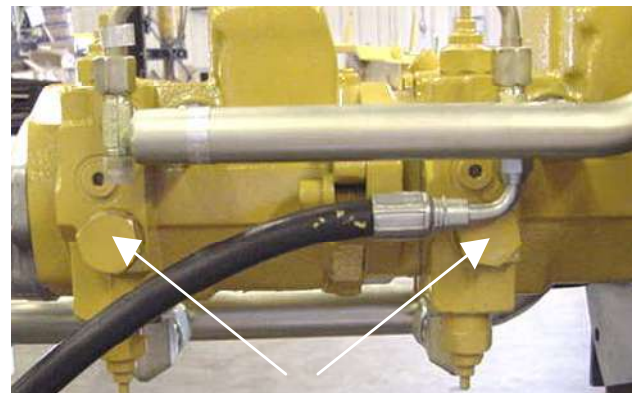

Figure 0-3

10-103

1. Remove belly pan and locate the charge pressure relief valves on the left side of the tandem pump.

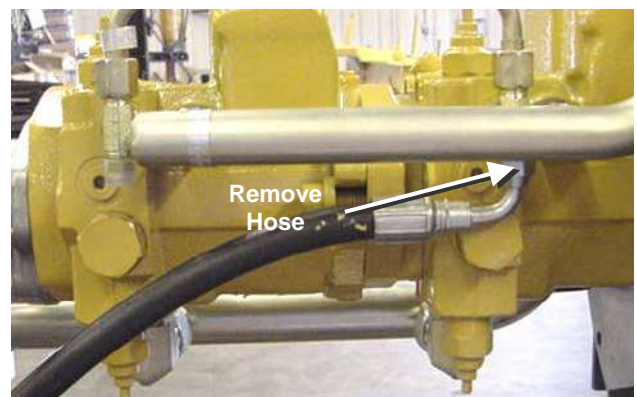

Figure 0-4

10-104

**17. Hydraulic Pressure Check & Adjustment**

- Remove the hose coupling from the tandem pump T-adapter to allow access to the front charge pressure relief valve locking screw.

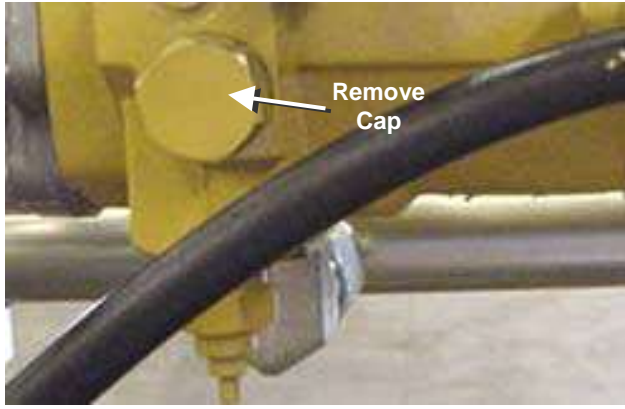

Figure 0-5

10-105

- Unscrew and remove the charge pressure relief valve locking screw. The valve piston and o-ring will remain attached to the locking screw when the locking screw is removed.

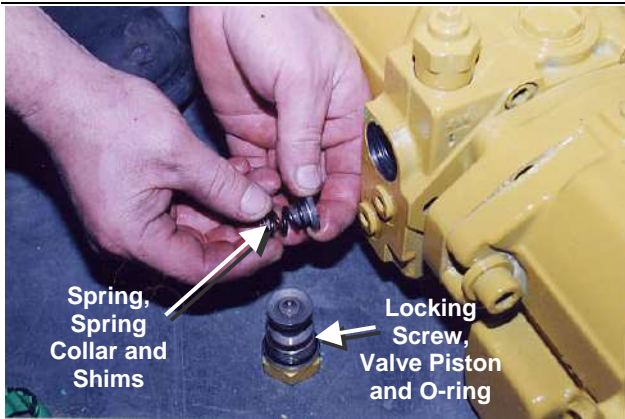

Figure 0-6

10-106

- Extract the spring, spring collar and shims from the charge pressure relief valve cavity. The front and rear charge pressure relief valves are identical.
- Adjust the charge pressure by adding or removing shims. Contact Manufacturer.
- Insert the spring, spring collar and shims in the charge pressure relief valve cavity.
- Install the charge pressure relief valve locking screw (with valve piston and o-ring attached).

- Repeat procedure on remaining charge pressure relief valve. The charge pressure relief valves must have the same number of shims.
- Connect the hose coupling on the tandem pump T-adapter.
- Check the charge pressure.
- Install the belly pan.

**Drive-Pressure Relief Valve Adjustment**

The service tools required for drive-pressure relief valve adjustment are listed in Table 0-3. Use manufacturer-recommended tools whenever possible.

Table 0-3

Required Tools
Combination Wrench
Socket Wrench

**! WARNING !**

Hot oil can cause personal injury. Lower all attachments and make sure the oil is cool before removing any components or lines.

Remove the oil filler cap only when the engine is stopped and the filler cap is cool enough to touch with your hands.

**NOTICE**

Collect and contain liquids in a suitable container. Dispose of all liquids according to local regulations and mandates.

**Note:** During disassembly, plug all hoses and tubes to prevent fluid loss and contamination of the system fluids.

- Remove the seat. Refer to *Chapter 6. Seat Removal.*
- Remove the fuel tank. Refer to *Chapter 6. Fuel tank Removal.*
- Remove belly pan.



**17. Hydraulic Pressure Check & Adjustment**

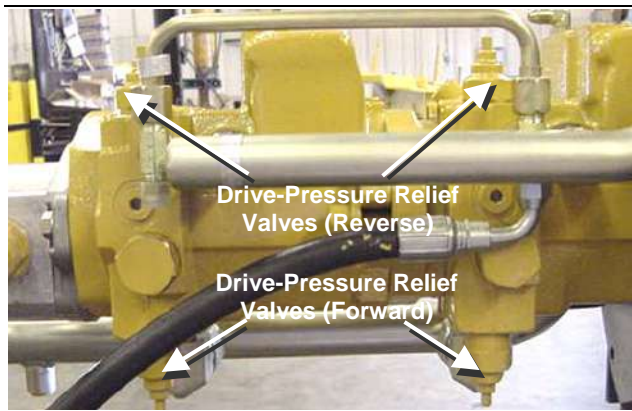

Figure 0-7

10-107

4. Locate the drive-pressure relief valves.



Figure 0-8

10-108

5. Unscrew and remove the necessary drive-pressure relief valve locking screw. The drive-pressure relief valve o-ring will remain attached to the locking screw when the locking screw is removed.



Figure 0-9

10-109

6. Extract the high-pressure relief valve collar, valve spring, spring loading nut and pressure spring from the valve cavity.
7. Adjust the drive pressure by turning the spring loading nut. Turning Clockwise will increase pressure. Never adjust by more than a quarter turn before checking pressure.
8. Insert the high-pressure relief valve collar, valve spring, spring loading nut and pressure spring in the valve cavity.
9. Replace the high-pressure relief valve locking screw and o-ring.

**Auxiliary Pressure Check & Adjustment**

The service tools required for the auxiliary pressure check and adjustment are listed in Table 0-1. Use manufacturer-recommended tools whenever possible.

Table 0-4

Required Tools
Pressure Gauge
Allen Wrench



Figure 10

10-110

1. Insert the hydraulic gauge into one of the attachment quick couplers.

Rubber Track Loader  
**17. Hydraulic Pressure Check & Adjustment**



Figure 11 10-111

2. Make sure the auxiliary mode switch is in the continuous (down) position.



Figure 12 10-112

3. Engage the continuous flow switch next to the loader control joystick. Make sure it is in the direction that sends flow to the gage.

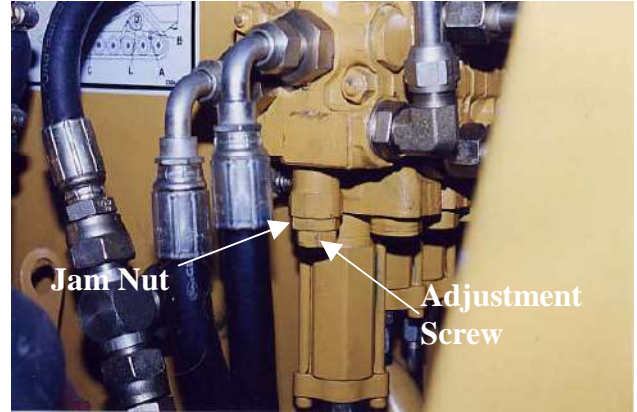

Figure 13 10-113

4. Loosen the jam nut and turn the adjustment screw in with an allen wrench to increase pressure and turn screw out to decrease pressure. Tighten jam nut when after adjustment has been made.





# Index

## A

Access Cover Removal and Installation.....	8-5
Air Filter Change Procedures.....	16-3
Asbestos Information.....	1-4
Auxiliary Circuit System.....	3-2
Auxiliary Gear Pump Removal and Installation.....	10-2

## B

Battery Removal and Installation.....	11-5
Brake Removal and Installation.....	12-4

## C

Chassis Disassembly and Assembly.....	6-1
Console Gauge/Warning Panel Removal and Installation.....	5-4

## D

Dash Panel.....	4-1
Drive Control.....	4-1
Drive Control Joystick Removal and Installation.....	9-1
Drive Loop System.....	3-3
Drive Motor Removal and Installation.....	12-13

## E

Engine Components Disassembly and Assembly.....	11-1
Engine Oil Filter Removal and Installation.....	11-1
Engine Oil Specifications.....	16-1
Exhaust Pipe Removal and Installation.....	11-3

## F

Fan and Fan Shroud Removal and Installation.....	7-2
Fan Guard Removal and Installation.....	7-1
Filler Cap Assembly Removal and Installation.....	8-4
Filter Assembly Removal and Installation.....	8-1
Filter Element Removal and Installation.....	8-1
Filtering and Cooling System.....	3-1
Fuel Filter Change Procedures.....	16-3
Fuel Sending Unit Removal and Installation.....	6-2
Fuel, Bleeding.....	11-7
Fuel Specifications.....	16-3
Fuel Tank Removal and Installation.....	6-4
Fuse Box.....	16-4

## G

Gauge/Warning Light Panel.....	4-2
Grease Fittings.....	16-5

## H

Hydraulic Fluid and Filter Change Procedures.....	16-2
Hydraulic Reservoir Disassembly and Assembly.....	8-1
Hydraulic Reservoir Cleaning Procedures.....	8-9
Hydraulic Pressure Check & Adjustment.....	17-1

## I

Ignition Switch Removal and Installation.....	5-2
Information Messages.....	1-1

## L

Lap bar Gas Assist Spring Removal and Installation.....	5-5
Latch Pin Assembly Removal and Installation.....	14-1
Lift Cylinder Removal and Installation.....	13-1
Light Bar Removal and Installation.....	5-1
Loader Control Joystick Removal and Installation.....	9-1
Loader Control.....	4-1
Loader Disassembly and Assembly Procedures.....	13-1

Loader Float Magnet Removal and Installation.....	9-4
Loader Valve Removal and Installation.....	9-7
Loader/Transmission Controls Disassembly and Assembly.....	9-1
Low-Flow Relief Valve Removal and Installation.....	13-5

## M

Machine Controls and Instrumentation.....	4-1
Machine Labels and Decals.....	1-4
Maintenance Schedule.....	16-1
Muffler Removal and Installation.....	11-2

## O

Oil Change Procedures.....	16-1
Operator Enclosure Disassembly and Assembly.....	5-1

## P

Primary Air Filter Removal and Installation.....	11-1
Pump Drive Coupler Removal and Installation.....	10-6

## Q

Quick Attach Assembly Removal and Installation.....	14-3
---	------

## R

Radiator/Cooler Removal and Installation.....	7-4
Radiator/Oil Cooler Adjustment Procedures.....	7-7
Reservoir Gauge Removal and Installation.....	8-7

## S

Safety Air Filter Removal and Installation.....	11-1
Safety Messages.....	1-1
Safety Precautions.....	1-1
Seat Removal and Installation.....	6-1
Specifications.....	2-1
Sprocket Bearing Plate Removal and Installation.....	12-9
Sprocket Removal and Installation.....	12-12
Sprocket Roller Removal and Installation.....	12-3
Suction Screen Removal and Installation.....	8-8
System Diagrams.....	3-1

## T

Tandem Pump Removal and Installation.....	10-4
Throttle.....	4-1
Tilt Cylinder Removal and Installation.....	13-1
Track Removal and Installation.....	12-6
Track Tension Adjustment Procedures.....	16-4
Transmission and Drive Disassembly and Assembly.....	10-1
Troubleshooting.....	15-1

## U

Undercarriage Disassembly and Assembly.....	12-1
---	------

## W

Wheel Removal and Installation.....	12-1
-------------------------------------	------

---

**Terex Construction Americas**

8800 Rostin Road

Southaven, MS 38671

**(888)-201-6008**

**(662)-393-1800**

**www.terex.com**