

Language: English  
Geographic Region: All  
Serial Number Range: SN All



# SC50 Scout

## Service Repair Manual

This manual is complements of  
TrackLoaderParts.com

The world's best source for ASV parts.



# Table of Contents

<b>1. Product Safety</b>		<b>4. Maintenance</b>	
Chapter Overview	1-1	Chapter Overview	4-1
Safety Messages	1-1	Personal Safety	4-1
Information Messages	1-1	Dump Box Brace	4-1
Basic Precautions	1-1	Jacking Procedure	4-2
Safety Labels	1-1	Radiator/Oil Cooler (cleaning)	4-2
Protective Equipment	1-2	Engine & Chassis (cleaning)	4-2
Entering and Exiting	1-2	Maintenance Schedule	4-3
Lifting	1-2	Air Cleaner	4-4
Hot Fluids and Components	1-2	Fuel Filter	4-5
Corrosion Inhibitor	1-2	Water Separator	4-5
Batteries	1-2	Fuse Panel	4-5
Pressurized Items	1-2	Accessory Belts	4-5
Repair	1-3	Engine Oil/Filter Change	4-6
Work Tools	1-3	Engine Oil Specifications	4-7
Asbestos Information	1-4	Engine Oil Level Check	4-7
Machine Labels and Decals	1-4	Hydraulic Fluid/Filter Change	4-8
Product Identification Number	1-4	Undercarriages	4-9
Engine Serial Number	1-4	Grease Fittings	4-9
Machine Label and Decal Examples	1-5	Track Tension	4-9
		Track Removal	4-10
<b>2. Technical Specifications</b>		Track Installation	4-12
Specifications (SC-50)	2-1	Drive Sprocket Rollers	4-14
Engine	2-1		
Transmission	2-1	<b>5. Machine Controls and Instrumentation</b>	
Drive Pumps	2-1	Chapter Overview	5-1
Charge Pump	2-1	Machine Controls	5-1
Drive Motors	2-1	Steering Control	5-1
Steering Control (valve)	2-1	Directional Speed Control	5-1
Motion Control (forward/reverse)	2-1	Throttle	5-1
Auxiliary Pump	2-1	Attachment Control	5-1
Auxiliary Hydraulic Control Valve	2-1	Instrumentation	5-1
Oil Cooler	2-1	Switches	5-2
Critical Torque Specifications	2-1	Switch Panels	5-2
Service Tools	2-1		
		<b>6. Operator Enclosure</b>	
<b>3. Circuit Diagrams</b>		Chapter Overview	6-1
Chapter Overview	3-1	Personal Safety	6-1
Hydraulic Charge Circuit	3-1	Machine Preparation	6-1
Hydraulic Auxiliary Circuit	3-2	Removal & Installation	6-1
Hydraulic Drive Circuit	3-3	Seat	6-1
Steering Control Valve	3-4	Seat Switch	6-2
Auxiliary Control Block	3-5	Switches	6-2
Brake/2-speed Control Block	3-6	Front Fascia	6-3
Pilot Generation Block	3-7	Gauges & Hour Meter	6-3
Shuttle Block	3-8	Engine Cover	6-4
Directional Control Valve	3-9	Steering Wheel & Mechanism	6-4
		Dash Panel	6-6

**Table of Contents**

<b>7. Chassis and Fuel Tank</b>		<b>12. Undercarriage</b>	
Chapter Overview . . . . .	7-1	Chapter Overview . . . . .	12-1
Personal Safety . . . . .	7-1	Personal Safety . . . . .	12-1
Machine Preparation . . . . .	7-1	Machine Preparation . . . . .	12-1
Removal & Installation . . . . .	7-1	Removal & Installation . . . . .	12-1
Hand Throttle Assembly . . . . .	7-1	Idler Wheels 10" . . . . .	12-1
Cargo Bed . . . . .	7-3	Idler Wheels 14" . . . . .	12-3
Fuel Sending Unit . . . . .	7-4	Drive Sprocket . . . . .	12-3
Fuel Tank . . . . .	7-4	Drive Motor . . . . .	12-5
R.O.P.S. (rollcage) . . . . .	7-5	Grease Tensioner . . . . .	12-6
Rear Console . . . . .	7-6		
Torsion Axles . . . . .	7-7		
<b>8. Radiator and Oil Cooler</b>		<b>13. Hydraulic Component Service</b>	
Chapter Overview . . . . .	8-1	Chapter Overview . . . . .	13-1
Personal Safety . . . . .	8-1	Personal Safety . . . . .	13-1
Machine Preparation . . . . .	8-1	Disassembly & Assembly . . . . .	13-1
Removal & Installation . . . . .	8-1	Hydraulic Cylinders . . . . .	13-1
Radiator/Oil Cooler . . . . .	8-1	Auxiliary Control Valve . . . . .	13-4
Fan, Fan Spacer & Shrouding . . . . .	8-2	Drive Motor (brake portion) . . . . .	13-5
		Drive Motor (motor portion) . . . . .	13-6
		Drive Pump Relief Valves . . . . .	13-8
		Posi-Power Relief Valve . . . . .	13-8
		Drive Pump (disassembly) . . . . .	13-9
		Drive Pump (assembly) . . . . .	13-11
		Auxiliary Pump . . . . .	13-12
<b>9. Hydraulic Reservoir</b>		<b>14. Hydraulic Pressure</b>	
Chapter Overview . . . . .	9-1	Chapter Overview . . . . .	14-1
Personal Safety . . . . .	9-1	Personal Safety . . . . .	14-1
Machine Preparation . . . . .	9-1	Contamination Inspection . . . . .	14-1
Removal & Installation . . . . .	9-1	Hydraulic Test & Troubleshooting . . . . .	14-1
Hydraulic Reservoir . . . . .	9-1	Charge Pressure Check & Adjust . . . . .	14-1
Suction Screen . . . . .	9-3	Auxiliary Pressure Check & Adjust . . . . .	14-3
		Drive Pressure Check & Troubleshooting . . . . .	14-4
		Posi-Power Check & Adjust . . . . .	14-5
<b>10. Hydraulic Components</b>		<b>15. Troubleshooting</b>	
Chapter Overview . . . . .	10-1	Chapter Overview . . . . .	15-1
Personal Safety . . . . .	10-1	Personal Safety . . . . .	15-1
Machine Preparation . . . . .	10-1	Visual Inspection . . . . .	15-1
Removal & Installation . . . . .	10-1	Troubleshooting . . . . .	15-1
Charge/Auxiliary Pump . . . . .	10-1		
Tandem (Drive) Pump . . . . .	10-2	<b>16. Lubricant and Fuel Specifications</b>	
2-speed/Brake Manifold . . . . .	10-5	Chapter Overview . . . . .	16-1
Shuttle Block . . . . .	10-6	Fluids & Fuel Specifications . . . . .	16-1
Pilot Generation Block . . . . .	10-7		
Auxiliary Valve/Solenoid Block Assembly . . . . .	10-8	<b>17. Service Aids and Supplements</b>	
Steering Valve & Plunger . . . . .	10-9	General Torque Specifications . . . . .	17-1
Directional Control Valve . . . . .	10-10	Electrical Schematic . . . . .	17-2
		Hydraulic Schematic . . . . .	17-3
<b>11. Engine</b>			
Chapter Overview . . . . .	11-1		
Personal Safety . . . . .	11-1		
Machine Preparation . . . . .	11-1		
Removal & Installation . . . . .	11-1		
Battery . . . . .	11-1		
Exhaust . . . . .	11-2		
Air Cleaner Housing . . . . .	11-4		
Engine . . . . .	11-5		

# 1. Product Safety

## Chapter Overview

This chapter contains product safety information for the SC-50 Utility Vehicle. Read and understand all product safety information before attempting to service any Rubber Track Utility Vehicle.

## Safety Messages

Safety messages are included in this document to serve as warnings of potentially dangerous conditions. Failure to follow their instructions could result in injury or death.

These messages are identified by the headings:  
**!DANGER!.....!WARNING!.....!CAUTION!.**

The messages are to be understood as:  
**Attention! Your Safety Is Involved!**

The information that follows each heading describes the potential hazard and the precautions necessary to protect yourself and others from injury. Instructions may be written or pictorially presented.

### **!DANGER!**

This symbol is used to alert service personnel of an imminently hazardous situation that will result in serious injury or death.

### **!WARNING!**

This symbol is used to alert service personnel of a potentially hazardous situation that could result in serious injury or death.

### **!CAUTION!**

This symbol is used to alert service personnel of an unsafe practice that could result in injury.

## Information Messages

Information messages are also included in this document to supplement the instructions and photographs in each chapter. These messages are identified by the labels **NOTICE** or **Note**.

### **NOTICE**

This label is used to alert service personnel of a situation that could lead to equipment or machine damage.

---

**Note:** This label is used to provide important additional information, further explanation, comments or to stress the importance of a topic.

---

The person(s) in charge of servicing a Rubber Track Utility Vehicle may be unfamiliar with many of the systems on the machine. This makes it especially important to use caution when performing service tasks. Familiarize yourself with the affected system(s) and components before attempting any type of maintenance or service.

**It is not possible to anticipate every potential hazard. The safety messages included in this document and displayed on the machine are not all-inclusive. They are intended to make you aware of potential risks and encourage a safe approach to performing service work. If you use a tool, procedure, work method or operating technique that is not specifically recommended by ASV, you must satisfy yourself that it is safe for you and others. You must also ensure that the machine will not be damaged or be made unsafe by the operation, lubrication, maintenance or repair procedures that you choose.**

## Basic Precautions

### **!WARNING!**

Improper or incomplete maintenance/repair of a Rubber Track Utility Vehicle can be dangerous and may result in machine damage, injury or even death.

Do not attempt to perform any type of repair or maintenance on a Rubber Track Utility Vehicle until you have read and fully understood this manual.

Refer to the Operator's manual for instructions regarding proper machine operation techniques before operating any Rubber Track Utility Vehicle.

---

Following is a list of basic precautions that should always be observed.

## Safety Labels

Safety labels are displayed in various places throughout the machine to serve as warnings of potentially dangerous conditions. Read and understand all "Safety" labels before attempting to operate, maintain or repair the machine. Replace any damaged, illegible or missing labels as necessary.

## 1. Product Safety

---

### Protective Equipment

Always wear appropriate protective equipment for working conditions when working on or around a Rubber Track Utility Vehicle. Wear hard hats, protective glasses, safety shoes and any other equipment necessary to ensure your safety and the safety of others as you work. In particular, wear protective glasses when pounding on any part of the machine or its work tool with a hammer or sledge. Do not wear loose clothing or jewelry that can catch on components and cause injury. If welding is required, use welding gloves, helmet (proper UV eye protection), apron, boots and any other protective clothing necessary to ensure your safety and the safety of others while welding. Avoid wearing flammable or heat sensitive clothing while performing tasks that involve welding.

### Entering and Exiting

Always use caution when entering or exiting a Rubber Track Utility Vehicle. When entering or exiting, always use the handholds located on the ROPS assembly. Never enter or exit the machine while it is in motion. Do not use the track as a step to enter or exit the machine or to gain access to the cargo bed.

### Lifting

Use a hoist when lifting components that weigh 23 kg (50 lb) or more, to avoid back injury. Make sure all chains, hooks, slings, etc., are in good condition and are of the correct capacity. Be sure hooks are positioned correctly and equipped with a spring latch. Lifting eyes are not to be side loaded during a lifting operation.

### Hot Fluids and Components

Stay clear of hot components and system fluids of the engine, exhaust, radiator/oil cooler and hydraulic lines/tubes. Also, use caution when removing fill caps, breathers and plugs on the machine. Hold a rag over the cap or plug to prevent being sprayed or splashed by liquids under pressure. Be especially careful if the machine has been operated recently, fluids may still be hot. To ensure your safety, allow the machine to cool before attempting any service procedure that involves hot fluids or components.

### Corrosion Inhibitor

Corrosion inhibitor contains alkali. Avoid contact with eyes. Avoid prolonged or repeated contact with skin. Do not take internally. In case of contact, wash skin immediately with soap and water. For eyes, flush with large amounts of water for at least 15 minutes. Call Physician. Keep out of reach of children.

### Batteries

Do not smoke when inspecting the battery electrolyte level. Never disconnect any charging unit circuit or battery circuit cable from the battery when the charging unit is operating. A spark can cause an explosion from the flammable vapor mixture of hydrogen and oxygen that is released from the electrolyte through the battery outlets. Do not let electrolyte solution make contact with skin or eyes. Electrolyte solution is an acid. In case of contact, immediately wash skin with soap and water. For eyes, flush with large amounts of water for at least 15 minutes. Call Physician. Keep out of reach of children.

### Pressurized Items

1. Do not use hands or any other body part to check for fluid leaks in the hydraulic system. Always use a solid material like wood or metal to check for this type of leak. Leaking fluid under pressure can penetrate body tissue. Fluid penetration can cause serious injury and even death. If fluid is injected into your skin, get treatment immediately. Seek treatment from a doctor that is familiar with this type of injury.
2. Relieve pressure from the hydraulic system before disconnecting or removing any lines, fittings or related items. Do this by relaxing all hydraulic actuators. Be alert for possible pressure release when disconnecting any device from a pressurized system.
3. Lower the dump box (if equipped) before performing any work on the machine. If this cannot be done, make sure it is securely braced to prevent it from dropping unexpectedly during service.
4. Loose or damaged fuel, oil, hydraulic, lines, tubes and hoses can cause fires. Do not bend or strike high pressure lines or install ones that have been bent or damaged. Check lines, tubes and hoses carefully. See item 1 for precautions on checking for fluid leaks.
5. Pressurized air or water can also cause injury. When pressurized air or water is used for cleaning, wear a protective face shield, protective clothing, and protective shoes. The recommended maximum air pressure for cleaning purposes is 205 kPa (30 psi). When using a pressure washer, keep in mind that nozzle pressures are typically very high. Generally, pressures are well above 13790 kPa (2000 psi). Follow all recommended practices provided by the pressure washer manufacturer.

## Repair

### !WARNING!

Accidental machine starting can cause injury or even death to personnel working on a Rubber Track Utility Vehicle.

As a precaution, disconnect the battery cables from the battery terminals, tape the battery clamps and remove the key from the ignition switch prior to performing any service work on a Rubber Track Utility Vehicle.

Place a "Do Not Operate" tag prominently on the machine to inform personnel that the machine is being serviced.

1. Disconnect the battery and discharge any capacitor before beginning work on a machine. Attach a **Do Not Operate** tag in the cab to alert any operator that service is in progress.
2. If possible, make all repairs with the machine parked on a level, hard surface. Use blocks to prevent the machine from rolling while working on or under the machine.
3. Do not work on or under any machine that is supported only by a hydraulic jack or hoist. Always use some sort of mechanical support to ensure that the machine will not fall. ASV jack stands work well to support the machine while performing maintenance or repair work.
4. Make sure the work area around the machine is safe and make yourself aware of any hazardous conditions that may exist. If the engine needs to be started inside an enclosure, make sure that the engine's exhaust is properly vented.
5. Be sure all protective devices including guards and shields are properly installed and functioning correctly before beginning any service task. If a guard or shield must be removed to perform the repair work, use extra caution.
6. Always use the appropriate tools for the work to be performed. Tools should be in good condition and you should understand how to use them properly before performing any service work.
7. When replacing fasteners, use parts of equivalent grade and size. Do not use a lesser quality fastener if replacements are necessary.
8. Be prepared to stop an engine if it has been recently overhauled or the fuel system has been recently serviced. If the engine has not been assembled correctly, or if the fuel settings are not correct, the engine can possibly overspeed and cause bodily injury, death or property damage. Be prepared to shut off the fuel and air supply to the engine in order to stop the engine.
9. Be careful when removing cover plates. Gradually back off the last two bolts or nuts located on opposite sides of the cover. Then, pry the cover loose to relieve any spring or other pressure before removing the last two nuts or bolts completely.
10. Repairs requiring welding should be performed only by personnel adequately trained and knowledgeable in welding procedures and with the guidance of appropriate reference information. Determine the type of metal being welded and select the correct welding procedure and filler material to provide a weld that is as strong or stronger than the original weld.
11. Take precautions to avoid damaging wiring during removal and installation operations. Carefully route wires so that they will not contact sharp corners, objects or hot surfaces during operation.
12. When performing service that requires the dump box (if equipped) to be in the raised position, always utilize the dump box brace to mechanically support its weight.
13. Relieve hydraulic system pressure by relaxing all hydraulic actuators prior to attempting any hydraulic maintenance or repair.
14. Always tighten connections to the correct torque specification. Make sure that all shields, clamps and guards are installed correctly to avoid excessive heat, vibration or unwanted contact between parts during operation. Shields that protect exhaust components from oil spray in event of a line, tube or seal failure must be correctly installed.
15. Do not operate a machine if any rotating part is damaged or contacts other parts during operation. Any high speed rotating component that has been damaged or altered should be checked for balance before use. Make sure all protective devices, including guards and shields, are properly installed and functioning correctly before starting the engine or operating the machine.

## Work Tools (Attachments)

Only use work tools that are recommended by ASV.

Make sure that all necessary guards and protective equipment are in place and functioning prior to operating any work tool.

## 1. Product Safety

Wear protective glasses and protective equipment as required by conditions or as recommended in the work tool's operation manual.

Ensure that all personnel are far enough away from the work area so they will not be struck by flying objects.

Stay clear of the cutting edges, pinching surfaces or crushing surfaces of the work tool while performing any work tool maintenance, testing or adjustments.

## Asbestos Information

Equipment and replacement parts shipped from the manufacturer are asbestos free. When replacement parts are required, use only genuine manufacturer's replacement parts

Use caution when handling replacement parts from another supplier if these parts contain asbestos. Avoid inhaling dust that might be generated when handling these components or when handling asbestos debris. Inhaling this dust can be hazardous to your health.

The components that may contain asbestos fibers are lining material, and some gaskets. The asbestos that is used in these components is usually encased in a resin or sealed in some way. Normal handling is not hazardous unless airborne dust containing asbestos is generated.

If dust that may contain asbestos is present, there are several guidelines that should be followed.

1. Never use compressed air for cleaning. Avoid brushing or grinding materials that contain asbestos. Use a wet method to clean up asbestos debris. A vacuum that is equipped with the high-efficiency particulate air filter (HEPA filter) can also be used.
2. Use exhaust ventilation on permanent machining jobs.
3. Wear an approved respirator if there is no other way to control the dust.
4. Comply with applicable rules and regulations for the work place. In the USA, use Occupational Safety and Health Administration requirements. These OSHA requirements can be found in 29 CFR 1910.1001.
5. Obey environmental regulations for disposal of asbestos.

6. Stay away from areas that might have asbestos particles in the air.

### **!WARNING!**

When replacement parts are required for your machine, use only genuine ASV replacement parts or parts that meet or exceed original specifications including, but not limited to physical dimensions, type, strength and material.

Installing lesser components can lead to premature failures, product damage, personal injury or death.

## Machine Labels and Decals

Labels and decals placed on the machine provide safety information and operating instructions. Familiarize yourself with the location and significance of these labels to ensure your safety.

## Product Identification Number

The Product Identification Number (PIN) is located between the seats on the rear enclosure (figure 1-1). Always provide the PIN when contacting the dealer about parts, service, warranty or accessories. No warranty claims will be processed unless the PIN is provided.

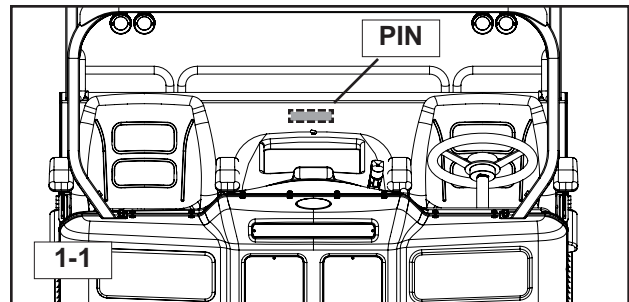

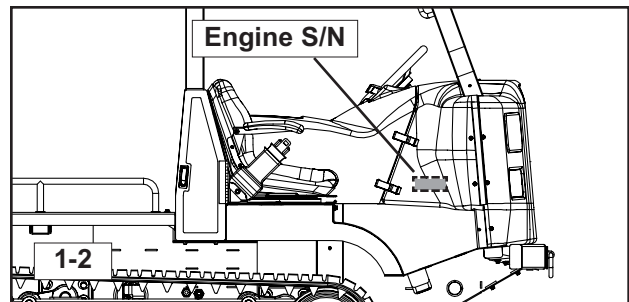

## Engine Serial Number

The engine serial number is located on the right side of the engine near the front, just above the injection pump. (figure 1-2)

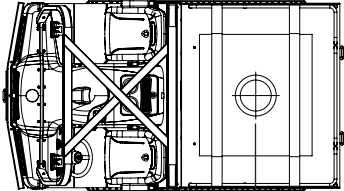
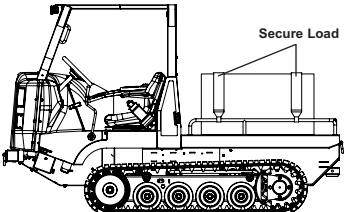
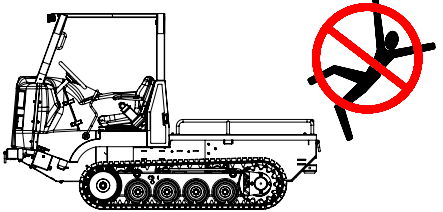

## Machine Label and Decal Examples

Examples of the labels and decals displayed on the machine are shown on this page.

<b>⚠ WARNING ⚠</b>		2051-678	
<p><b>Prior to Operating</b> Read and fully understand the operation and maintenance manual prior to operating this machine.</p>	<p><b>Pre-Start Checklist</b></p> <ol style="list-style-type: none"> <li>1. Operator and passenger (if present) seated inside cab.</li> <li>2. Seat belts fastened.</li> <li>3. Auxiliary hydraulic switch in neutral position.</li> <li>4. Bystanders clear of all moving components.</li> </ol>	<p><b>Vehicle Capacity</b> 1 operator, 1 passenger. <b>No Riders Permitted</b></p>	<p><b>Always</b></p> <ul style="list-style-type: none"> <li>• Keep hands and feet inside the cab.</li> <li>• Watch for branches or other hazards that may enter the cab.</li> <li>• Keep clear of the tracks while the machine is in motion.</li> </ul>
<p><b>Operating Position</b> Never operate the machine with any part of your body protruding out of the operator enclosure.</p> <p>Failure to do so may result in serious injury or even death.</p>	<p><b>Engine Warm-Up</b> Allow the engine to warm up to operating temperature prior to operation.</p>	<p><b>Carrying Loads</b> Center loads on cargo bed and secure to prevent shifting and maximize machine stability.</p>	<p><b>Never</b></p> <ul style="list-style-type: none"> <li>• Operate the machine under the influence of drugs or alcohol.</li> <li>• Operate in excess of GVW rating. (see o&amp;m manual)</li> </ul>
<b>⚠ CAUTION ⚠</b>		<b>⚠ CAUTION ⚠</b>	
<p>CARGO BED CAPACITY</p> <h1>4000 lb. (1814 kg)</h1> <p>Do not load the cargo bed in excess of the the cargo bed capacity rating. Carrying loads in excess of of this rating will void the warranty. Failure to observe or comply with precautionary notices may result in machine damage, serious injury or even death.</p>		 <p>Center Load</p>  <p>Secure Load</p>	
<b>⚠ WARNING ⚠</b>		<b>⚠ CAUTION ⚠</b>	
			
<p><b>No Riders</b> This vehicle is designed to carry one operator and one passenger seated inside the operator enclosure with safety belts fastened. Never allow additional passengers to ride in or on the machine. Failure to observe or comply with warnings may result in serious injury or even death.</p> <p style="text-align: right;">2051-699</p>		<p><b>Load Management</b> When hauling cargo, always position the load so that it is centered on the bed and orient it so that it rides as low as possible to maximize machine stability. Properly secure all loads prior to operation. Failure to observe or comply with precautionary notices may result in machine damage, serious injury or even death.</p> <p style="text-align: right;">2051-700</p>	
<b>⚠ WARNING ⚠</b>		<b>⚠ WARNING ⚠</b>	
<p><b>Vehicle Capacity</b> 1 operator, 1 passenger. <b>No Riders Permitted</b></p>	<p><b>Always</b></p> <ul style="list-style-type: none"> <li>• Keep hands and feet inside the cab.</li> <li>• Watch for branches or other hazards that may enter the cab.</li> <li>• Keep clear of the tracks while the machine is in motion.</li> </ul> <p style="text-align: right;">2051-679</p>	<p><b>The ROPS enclosure may not protect occupants in all foreseeable accidents including, but not limited to rollover.</b></p> <p style="text-align: right;">2051-684</p>	
<p><b>Passenger Position</b></p> <ul style="list-style-type: none"> <li>• Seated in passenger seat.</li> <li>• Seat belt fastened.</li> <li>• Hands/feet inside cab.</li> </ul>			



**Intentionally left blank**

## 2. Technical Specifications & Service Tools

### SC-50 Specifications

#### Engine

- Model: Perkins 404C-22
- Displacement: 2.2 liter
- Gross horsepower: 50 hp (37.3 kW)
- Torque: 105 lb-ft. (143 Nm)
- Idle rpm: 2800 (high idle); 1175 (low idle)
- Average water /thermostat temperature: 190°F, 87.8°C

#### Transmission

- Model: AA20VG45T tandem (Rexroth)

#### Drive Pumps

- Displacement: 2.349 in<sup>3</sup>/rev (38.5 cc/rev)
- Relief pressure: 5500 psi (380 bar)
- Flow: 28 gpm (106 lpm) @ 2800 rpm (high idle)

#### Charge Pump

- Displacement: 1.098 in<sup>3</sup>/rev (18 cc/rev)
- Relief pressure: 400-450 psi

#### Drive Motors

- Model: Rexroth MCR 5 (2-speed)
- Displacement: 50 in<sup>3</sup>/rev (820 cc/rev)

#### Steering Control (valve)

- Model: Husco AR1652

#### Motion Control (forward/reverse)

- Model: Rexroth 2TH6RP06

#### Auxiliary Pump

- Make: Haladex Barnes Hydraulics
- Type: Gear pump
- Displacement: 1.343 in<sup>3</sup>/rev (22 cc/rev)
- Max Flow: 16.3 gpm (61.7 lpm) @ 2800 rpm
- Relief pressure: 3000 psi (20,680 kPa)
- Cooling/filtering: Oil is filtered and cooled at all times. In auxiliary mode, the oil is filtered after the attachment to protect the machine if the attachment motor fails or contaminants are introduced from the quick couplers.

#### Auxiliary Hydraulic Control Valve

- Model: Husko
- Relief pressure: 3000 psi (20,684 kPa)
- Pilot pressure required to move spools: 180-220 psi (1241-1517 kPa)

#### Oil Cooler

- Operating pressure: 150 psi (1034 kPa)
- Bypass relief pressure: 80 psi (689 kPa)
- Hot oil sending unit: 225°F (107.2°C)
- Avg. oil operating temp. 50-60°F above ambient. (High flow application 80°F above ambient.)

#### Critical Torque Specs

- Transmission Mounting Bolts
  - 85 ft-lb. w/Blue Loctite
- Drive Sprocket Drive Tooth Bolts
  - 88 ft-lb. -Dry
- 10" Idler Wheel Retaining Nut
  - 111 ft-lb. - Dry
- 14" Idler Wheel Retaining Nut
  - 111 ft-lb. -Dry
- Drive Sprocket Lug Nut
  - 129 ft-lb. -Dry
- Drive Motor Mounting Bolts
  - 177 ft-lbs. -Dry

#### Service Tools

Listed below are common service tools which are identified and utilized in the service procedures described in this manual. Use tools recommended by ASV whenever possible to reduce risk of injury and or machine damage during service.

- ASV Jack Stands (2) (ASV P/N: 0402-900) (you will need crossmembers (2) P/N: 0403-472)
- Heavy Duty Hydraulic Jack (5-ton rating)
- Test Gauge Kit (ASV P/N: 0402-935)
- Ratchet Strap
- Long Pry Bar(s)
- ASV Service Cart (0402-871)

**Intentionally left blank**

# 3. Circuit Diagrams

## Chapter Overview

This chapter contains diagrams for the following SC-50 circuits and sub components: hydraulic charge circuit, hydraulic auxiliary circuit, hydraulic drive circuit, steering control valve, auxiliary control block, brake/2-speed control block, pilot generation (solenoid) block, shuttle block, and directional control valve.

## Hydraulic Charge Circuit

Figure 3-1 SC-50 Hydraulic Charge Circuit

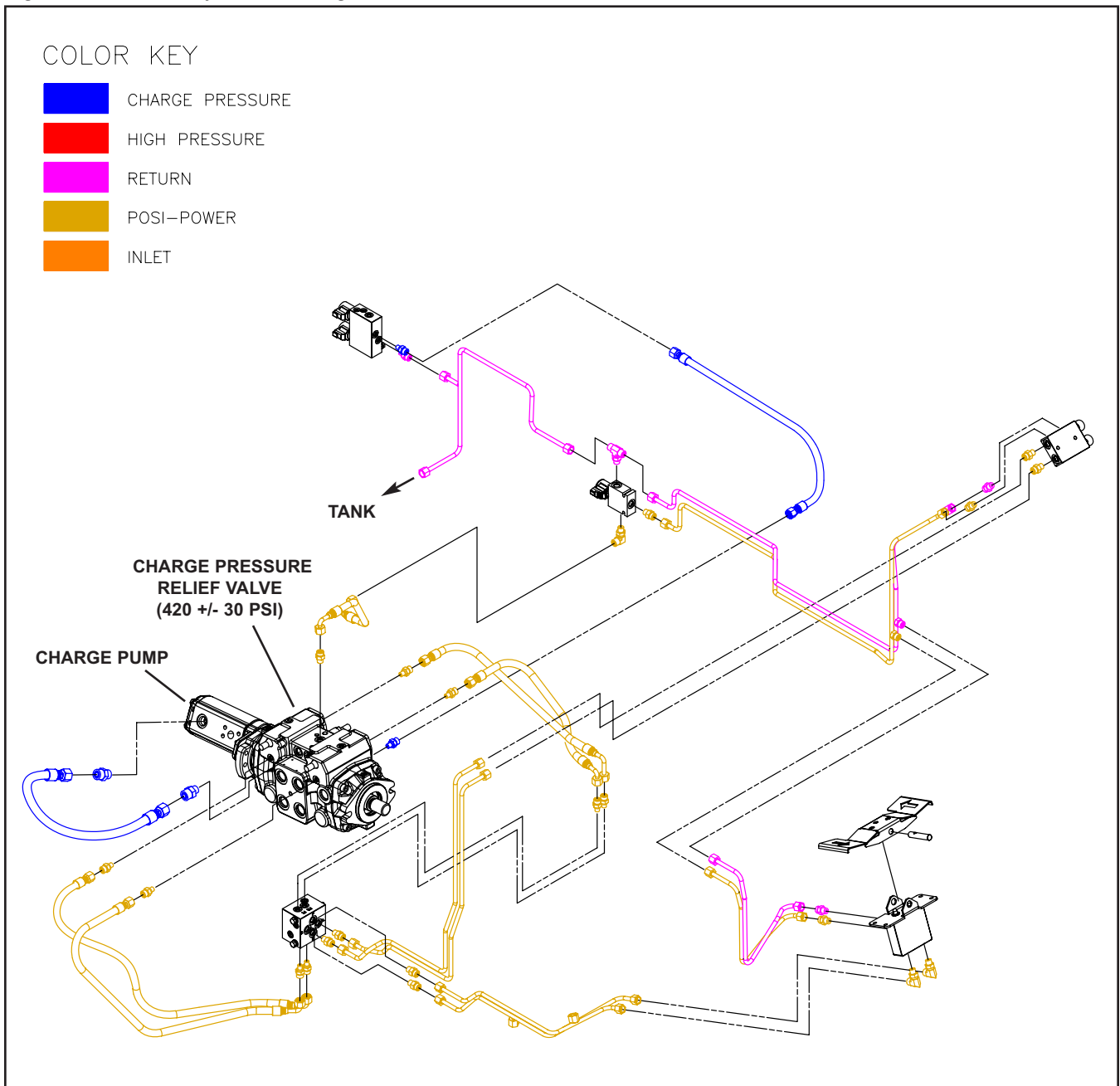

# Hydraulic Auxiliary Circuit

Figure 3-2 SC-50 Hydraulic Auxiliary Circuit

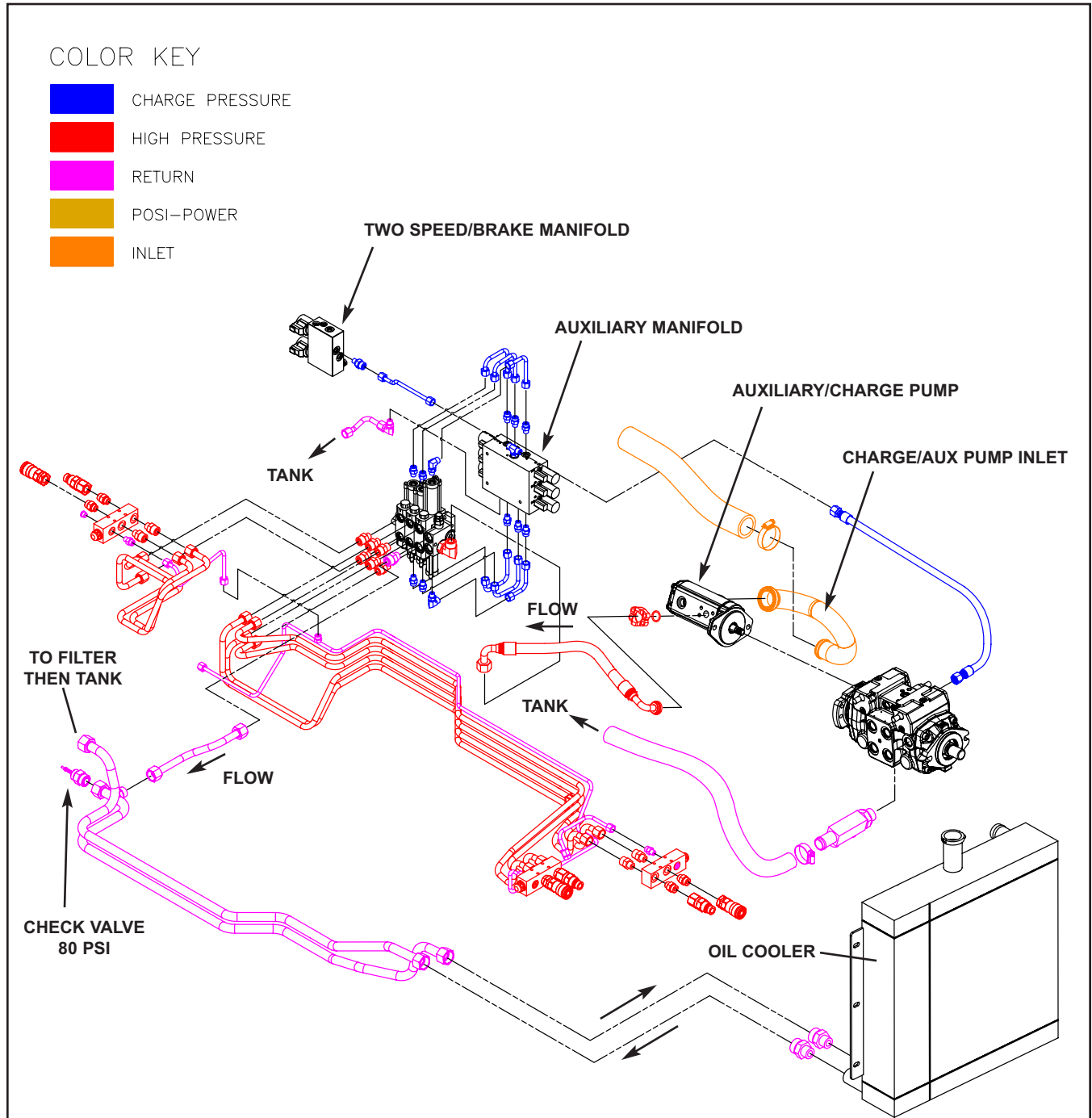

# Hydraulic Drive Circuit

Figure 3-3 SC-50 Hydraulic Drive Circuit

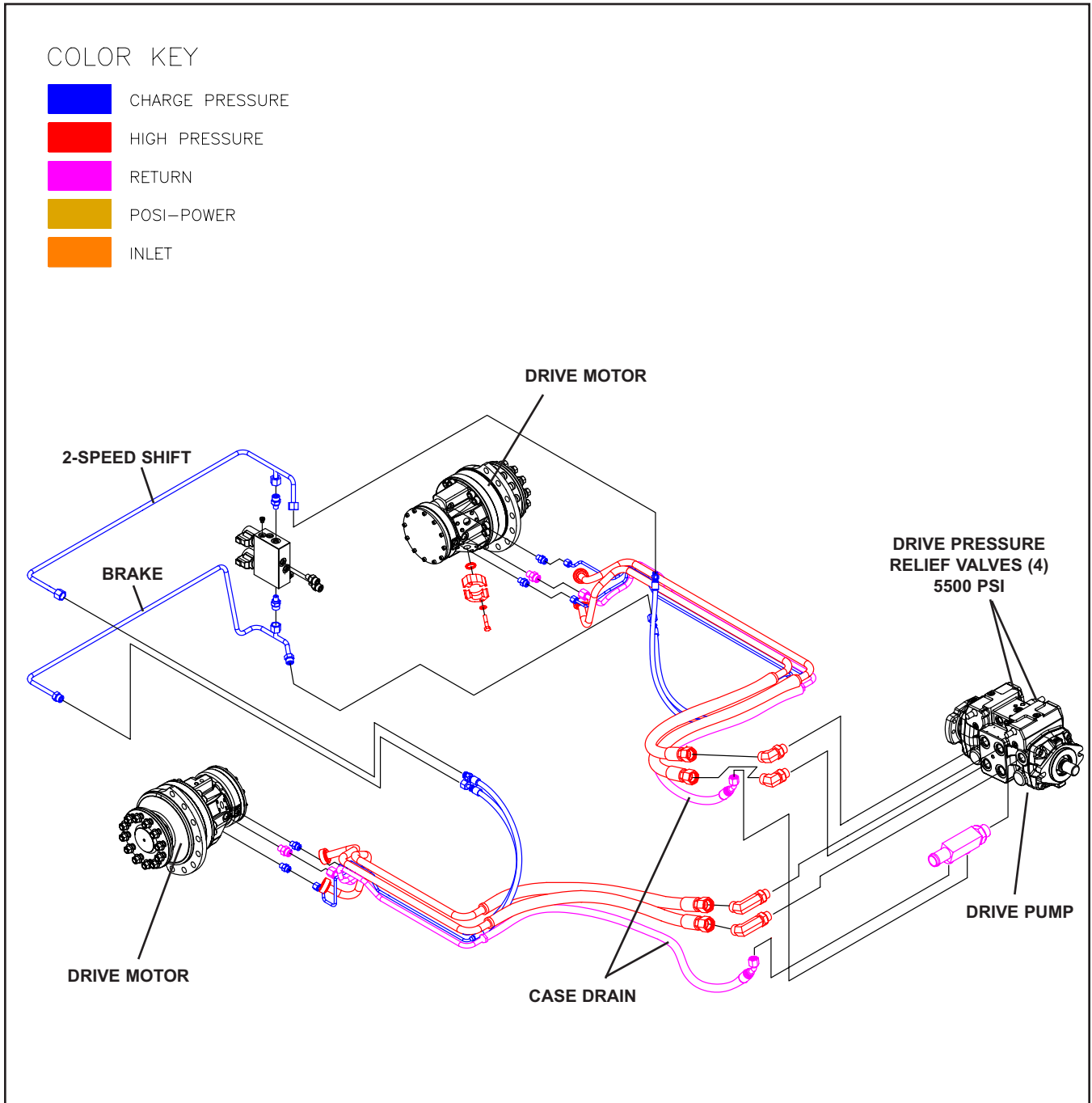

## Steering Control Valve

Figure 3-4 SC-50 Steering Control Valve

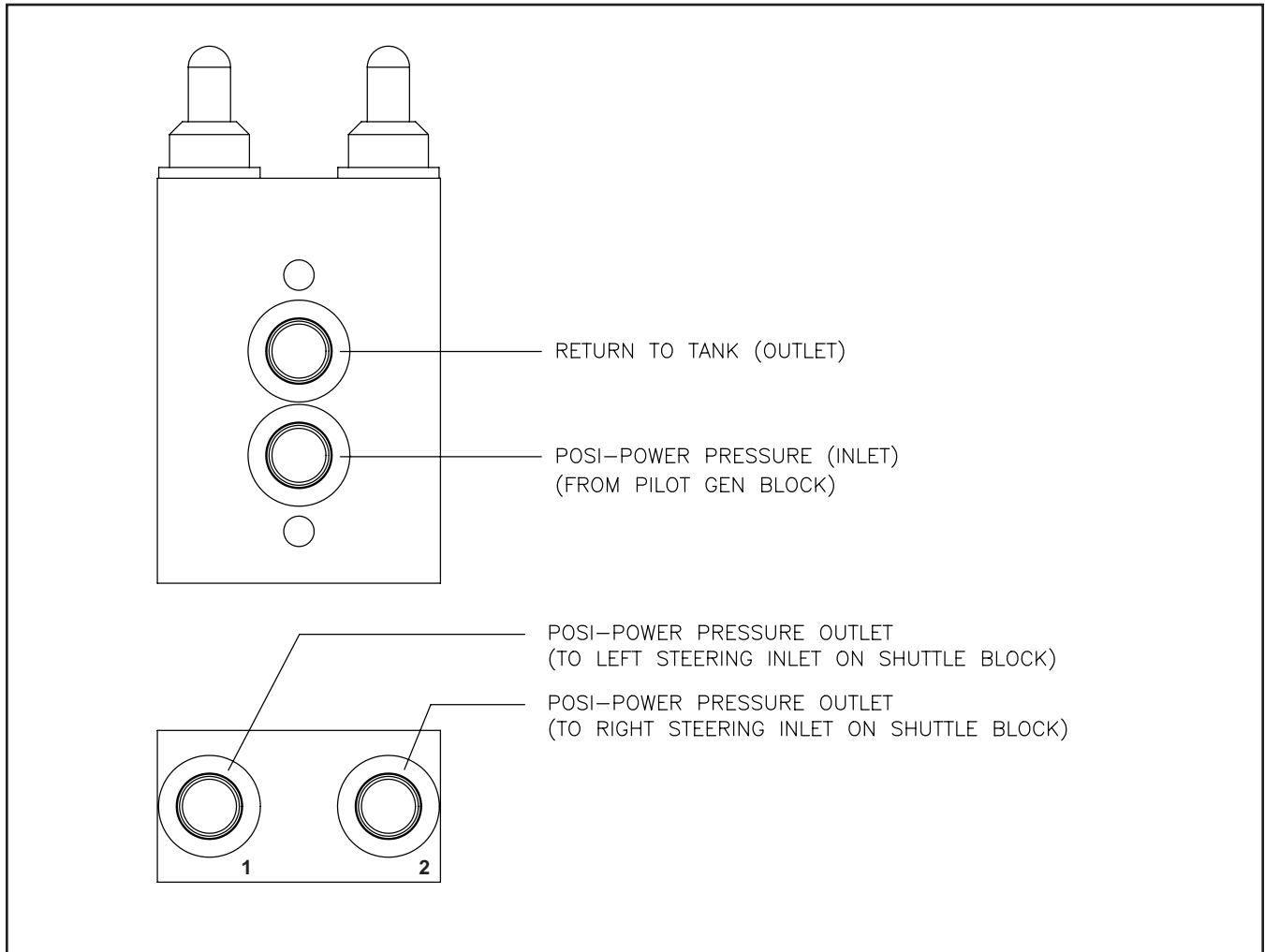

# Auxiliary Control Block

Figure 3-5 SC-50 Auxiliary Control Block

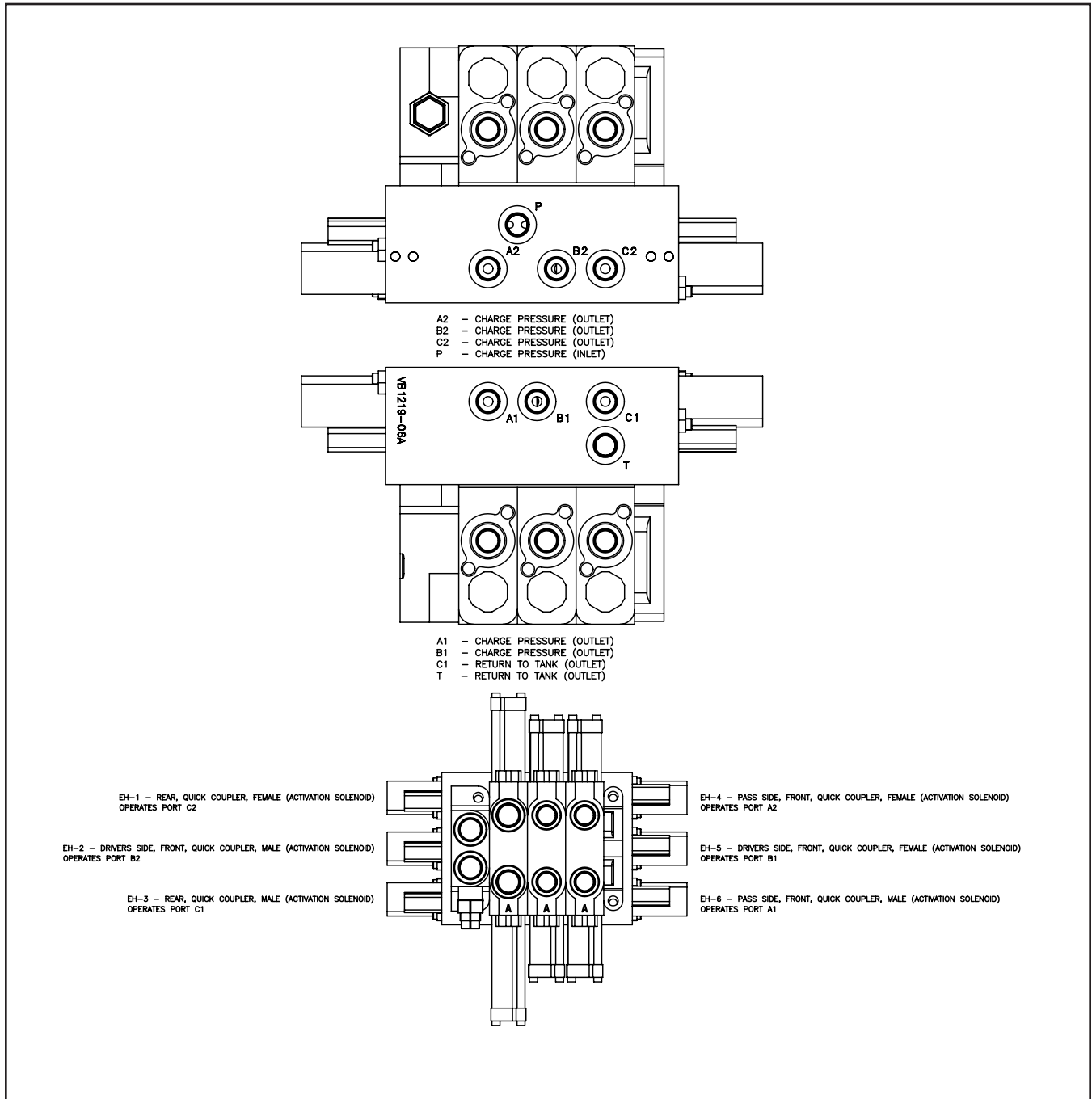



## Brake/2-Speed Control Block

Figure 3-6 SC-50 Brake/2-Speed Control Block

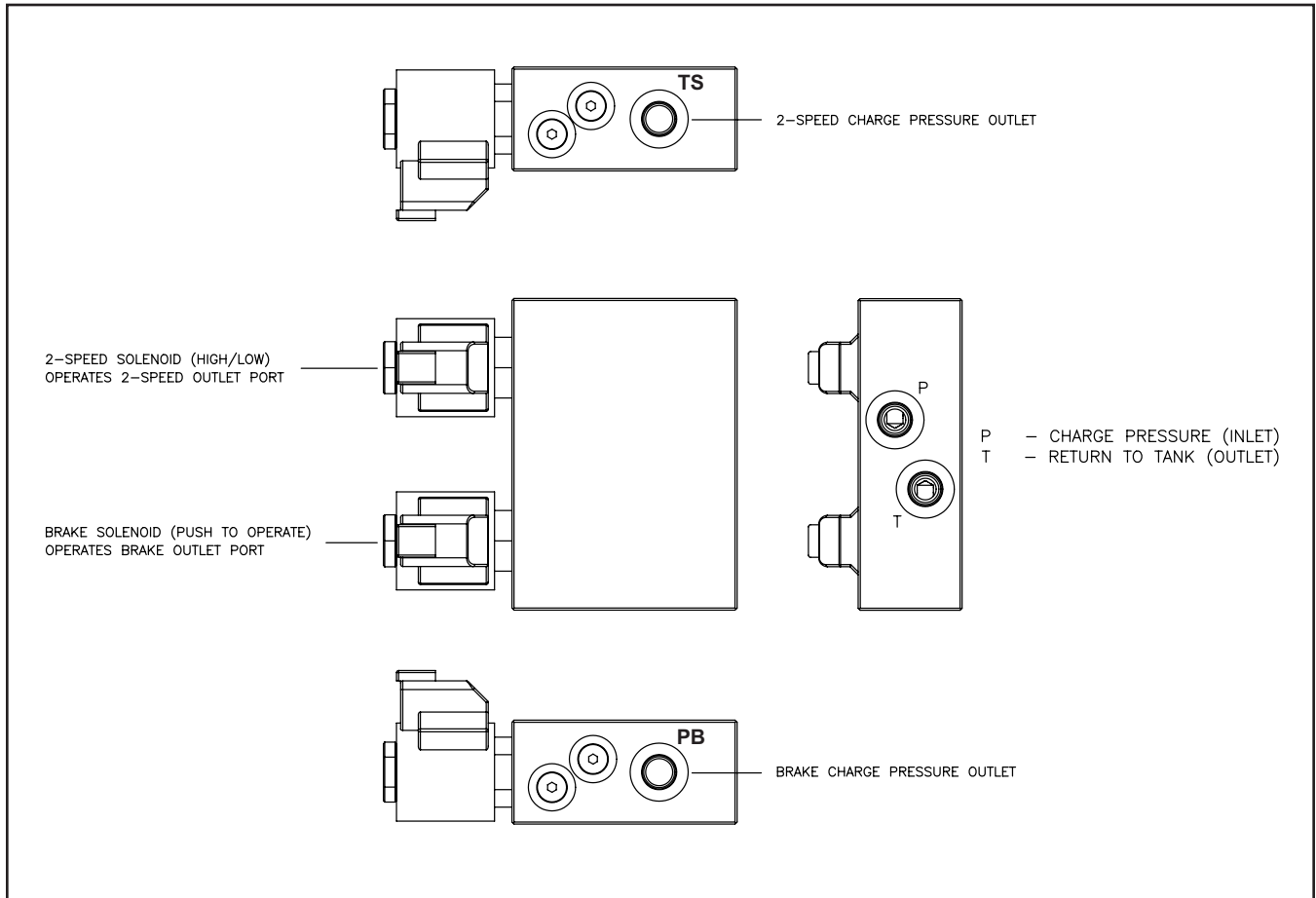

## Pilot Generation Block

Figure 3-7 SC-50 Pilot Generation Block

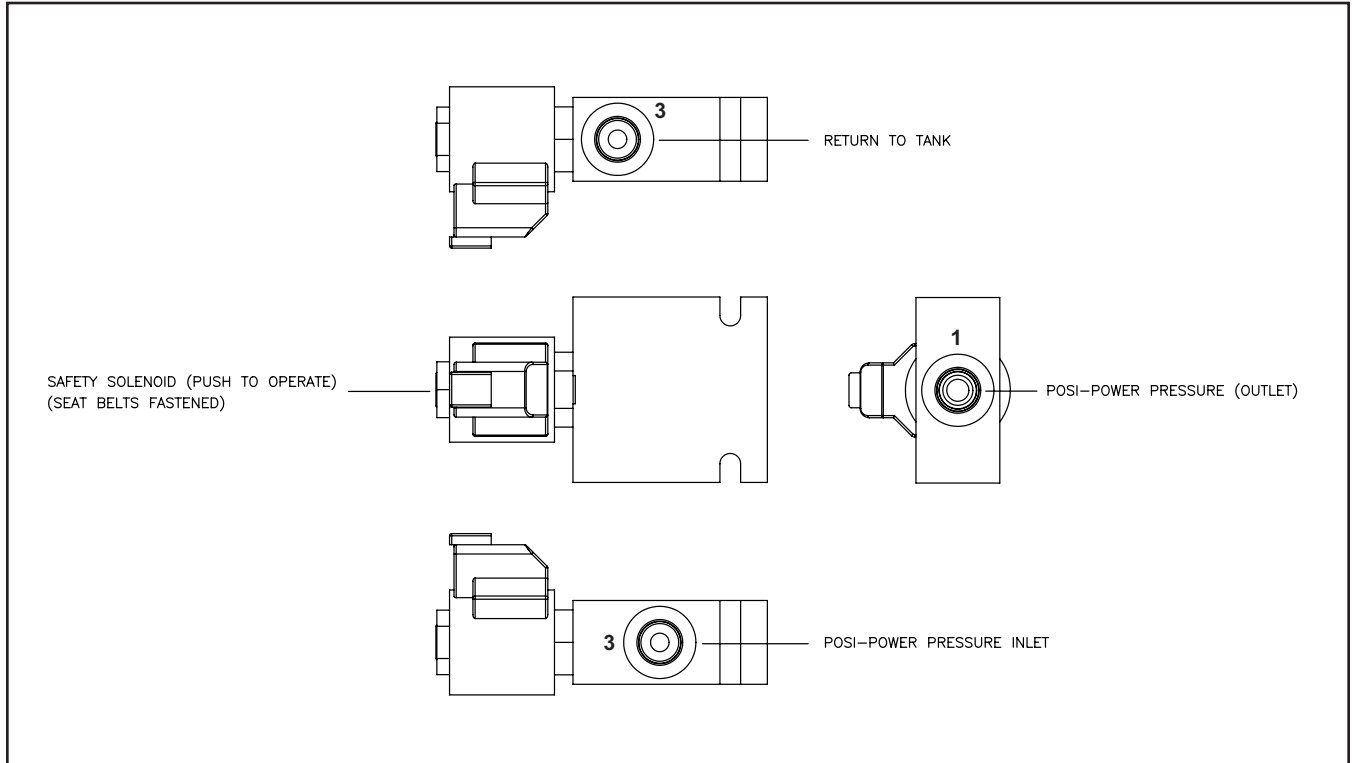

# Shuttle Block

Figure 3-8 SC-50 Shuttle Block

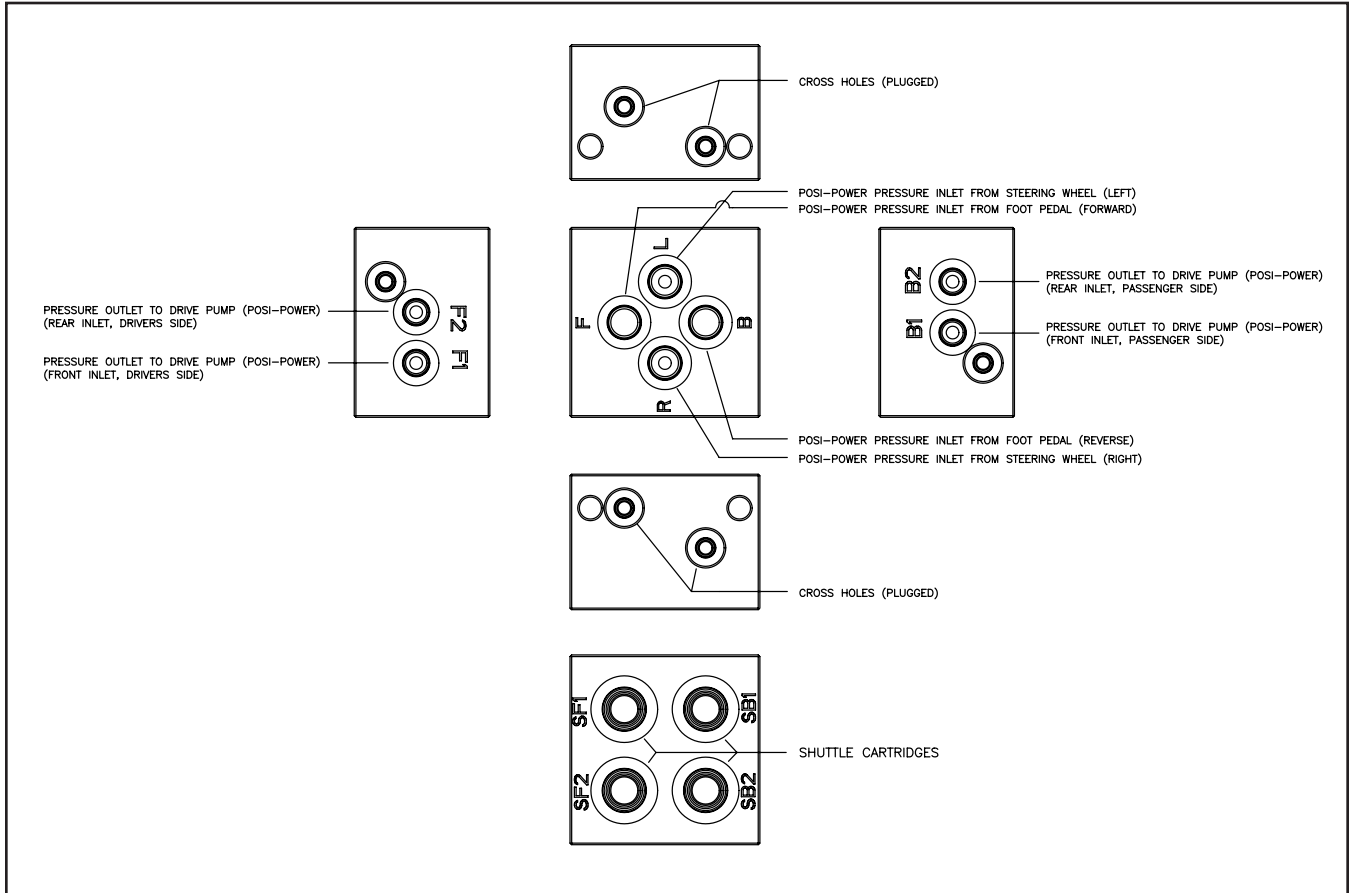

## Directional Control Valve

Figure 3-9 SC-50 Directional Control Valve

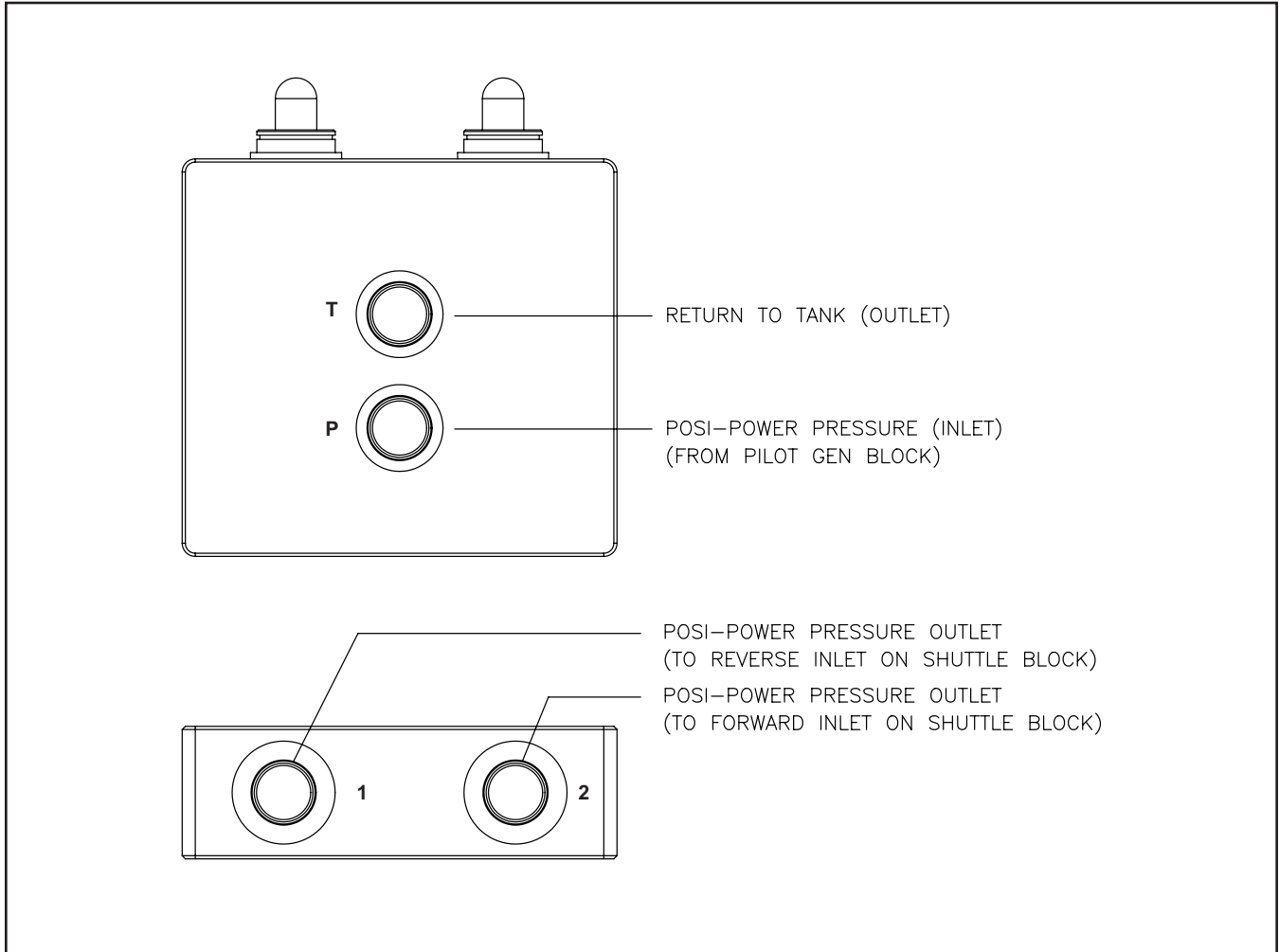

**Intentionally left blank**

# 4. Maintenance

## Chapter Overview

This chapter provides information on general maintenance procedures for the SC-50. If there is an issue that requires troubleshooting, refer to Chapter 15, Troubleshooting.

## Personal Safety

### **!WARNING!**

**Improper or incomplete maintenance/repair of a Rubber Track Utility Vehicle can be dangerous and may result in machine damage, injury or even death.**

**Do not attempt to perform any type of repair or maintenance on a Rubber Track utility Vehicle until you have read and fully understood this manual.**

**Refer to the Operation and Maintenance manual for instructions regarding proper machine operation techniques before operating any Rubber Track Utility Vehicle.**

Prior to performing any type of service or maintenance work on a Rubber Track Utility Vehicle, read and understand Chapter 1 (Product Safety) for personal safety information.

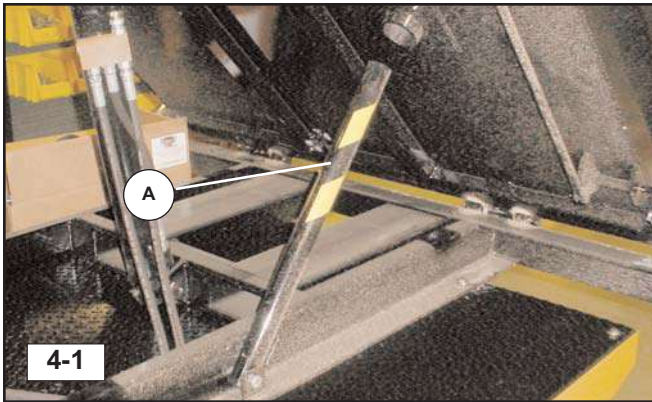

## Dump Box Brace (if equipped)

The dump box brace (A) is intended to keep service personnel safe when it is necessary to work on a machine with the dump box in the raised position. It is not safe to rely on the hydraulic system to hold the dump box in the raised position just as it is not safe to crawl under a machine supported only by a jack. The dump box brace is used to support the weight of the dump box much like jack stands are used to mechanically support vehicle weight.

### To install the dump box brace:

1. Park the machine on level ground in a safe area for performing service work.
2. Remove any load that may be in/on the dump box.
3. Make sure bystanders are clear of the dump box, then raise it to the upper limit.
4. Have an assistant raise the brace into position as shown (fig. 4-1).
5. Lower the dump box slowly until it comes to rest on the brace.
6. It is now safe to shut the engine off and exit the machine.

### **!WARNING!**

**Do not work on or near the machine with the dump box in the raised position unless the dump box brace has been correctly installed.**

### To remove the dump box brace:

1. Start the machine and raise the dump box until it is clear of the brace.
2. Once clear, have an assistant lower the brace back into its stowed position.
3. Once the brace has been stowed and the assistant is clear of the dump box, lower the box to the bed and shut the engine off to complete the procedure.

4. Maintenance



4-2



4-3

**Jacking Procedure**

Occasionally, the Scout may need to be suspended off of the ground to perform maintenance. Exercise caution when jacking the machine. Always use a jack that is capable of lifting the machine and support machine weight with ASV approved jack stands during service. Never work on or under a machine supported only by a hydraulic jack.

**To safely jack the Scout:**

1. Remove any attachments fastened to the machine or loads placed on the cargo bed.
2. Roll or slide your jack under the front of the machine and center the lifting pad directly beneath the center of the front torsion axle.
3. Once in place, jack the machine upwards making sure it remains stable until it has reached sufficient height to install an ASV jack stand beneath the machine.
4. Slide the jack stand into place making sure it is centered under the machine (left to right when viewed from the front) and far enough back for the machine to remain stable when the jack is lowered and the front of the machine rests on the stand.
5. Once the stand is in place, slowly lower the machine onto the stand, then remove the jack.

Repeat steps 2-5 at the rear of the machine should both ends of the machine need to be off of the ground for maintenance or service.

**NOTICE**

Lift the machine under the torsion axles only! Jacking the machine at any other place may cause damage.



4-4

**Radiator/Oil Cooler**

The radiator and oil cooler must be kept clean to ensure proper operation. Engine and hydraulic system overheating, damage and even failure can result if the radiator/oil cooler is not kept clean. A pressure washer or compressed air nozzle work well to blow debris clear of the fins in the radiator/oil cooler.

**Note:** If hydraulic oil or engine coolant warning lights illuminate during operation, increase cleaning intervals.

**To clean radiator/oil cooler:**

1. Make sure the engine is **off and cool**, then remove the front fascia to access the radiator/oil cooler.
2. Using compressed air or a pressure washer, thoroughly clean the radiator/oil cooler as shown.

**Note:** Make sure to keep the water nozzle at least 12" (8" for air) away from the cooler and that the spray is directed straight through the cooler. This will prevent cooling fins from being bent over which will decrease cooling performance.



4-5

**Engine & Chassis**

Periodic cleaning of the engine compartment and chassis area is also recommended to maintain safe and reliable operation. Clean as needed.

1. Remove the belly pans (2) from under the machine.
2. Remove the engine cover & cargo bed cover plate.
3. Pressure wash any debris from the engine compartment and chassis out through the lower opening.

**Maintenance Schedule**

<u>Maintenance Item</u>	<u>Service required</u>	<u>Interval</u>	<u>Notes</u>	<u>Service Capacity</u>
Grease fittings	Lubricate	Daily	(Torsion Axle Pivots)	
Fluid levels	Check	Daily	Adjust levels as necessary.	
Fan belt tension	Check	Daily	Adjust tension as necessary.	
Fan belt condition	Inspect	Daily	Replace if worn or damaged.	
Water separator	Drain	Daily		
Track condition	Inspect	Daily	Replace if severely damaged.	
Track tension	Inspect	Daily	Adjust tension as necessary.	
Air cleaners	Inspect	Daily	Replace if damaged or heavily soiled.	
Radiator/oil cooler fins	Inspect	Daily	Clean often (as necessary).	
Undercarriages	Inspect	Daily	Clean often (as necessary).	
Engine compartment	Inspect	Daily	Clean often (as necessary).	
Drive sprocket rollers	Inspect	50 hr.	Replace if damaged or worn. (35% min.)	
Engine oil and filter	Replace	12 Mo. or 500 hr.	Harsh conditions (6 Mo./250 hr. interval)	11.2 qt.
Hydraulic filter	Replace	250 hr.	Located in hydraulic tank (access in bed)	
Hydraulic oil	Replace	500 hr.	Service refill capacity only.	5.125 gal.
Fuel filter	Replace	500 hr.	Replace fuel filter element.	
Radiator coolant	Replace	3000 hr.	Coolant with SCA additive required.	1.75 gal



**4. Maintenance**

**Air Cleaner**

The Scout is equipped with two air filter elements that remove contaminants from the air drawn into the engine. Regular inspection and replacement is necessary to ensure proper performance and to prolong engine life.

To remove and inspect the air cleaner elements:

1. Turn the engine off.
2. Open the passenger side access door on the rear console enclosure (behind the seats) to access the air cleaner housing.
3. Release the latches securing the cover (A) to the air cleaner housing, then rotate the bottom of the cover (rubber boot) upward past the metal plate housing the filler openings. Slide the cover out face down between the door latch tab and the filler caps to remove it from the machine.
4. Remove the primary element (B) and inspect it. If it appears damaged in any way, replace it. If the element is heavily soiled, replace it. If it appears to be in good condition, clean the element (if necessary) and reinstall it.
5. Once the primary element has been removed, the secondary element (C) will be visible. Remove the element and inspect it. If it appears damaged or heavily soiled, replace it.
6. Install the new, or clean used elements into the housing as found upon removal.
7. Reverse steps 2 and 3 to reinstall the housing cover.

**Note:** The secondary element is not serviceable. It should be replaced after three cleanings of the primary filter.

**Note:** The primary element may be cleaned and reused up to five times if properly maintained, but should be replaced at least once a year.

**Primary Element Cleaning Procedure**

1. Remove loose dirt from the filter element with compressed air or a water hose.

**Compressed air:** 100 P.S.I. maximum with a 1/8" nozzle at least 2" away from the the filter.

**Water:** 40 P.S.I. maximum without a nozzle.

2. Soak the filter in a non sudsing detergent solution for at least 15 minutes moving it gently through the solution to further clean the element. Never soak for more than 24 hours.
3. Rinse the filter thoroughly with a gentle stream of water to remove all dirt and remaining detergent.
4. Allow the filter to dry completely before reinstalling it into the machine.

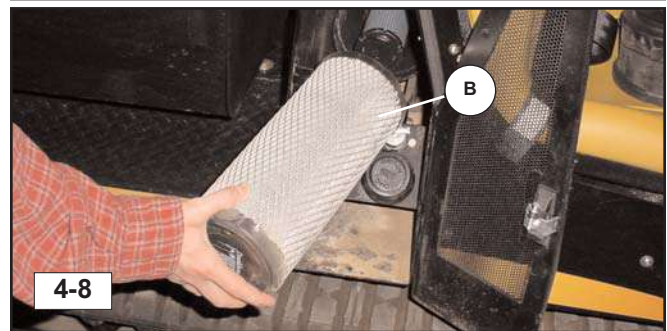
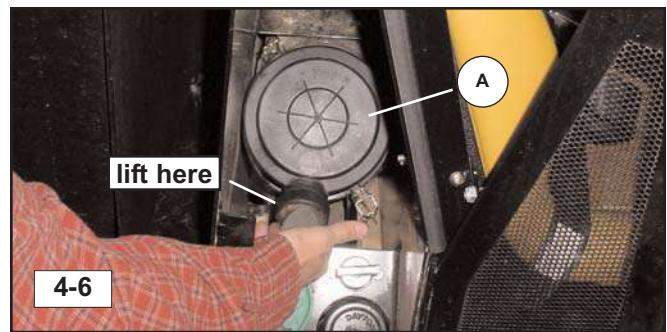

**NOTICE**

Do not use any heat source other than warm air at less than 160° F to dry the filter.

**NOTICE**

Do not clean the air filter elements while the engine warranty is in effect. During the warranty period, ASV recommends replacing the elements instead of cleaning them. Heavy-duty air filter manufacturers will not warrant the air filter once it has been cleaned.

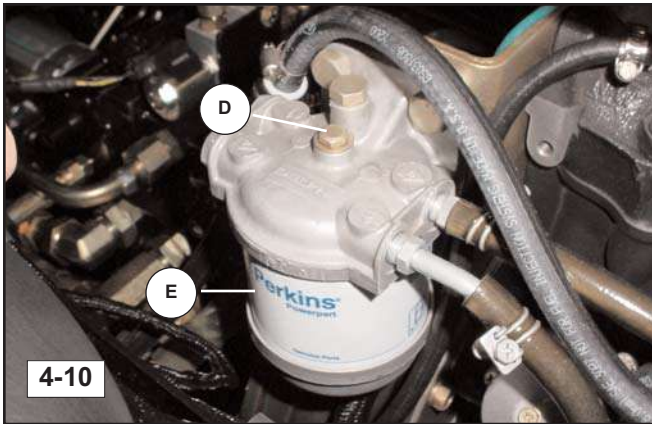

4-10

**Fuel Filter**

The fuel filter removes contaminants from the fuel as it enters the engine for combustion. Over time, the filter can become plugged and may cause the engine to lose power, run roughly or fail to start. The fuel filter should be replaced every 500 hours or more often as necessary to prevent these conditions from occurring.

**To change the filter:**

1. Thoroughly clean the outside of the filter assembly to reduce the chance of contaminants being introduced into the fuel system.
2. Loosen the retaining bolt (D) then remove the filter element (E) from the filter head and dispose according to local mandates and regulations.
3. Reinstall the filter assembly by reversing step 2.



4-11

**Water Separator**

The water separator removes water from the fuel supply as the engine runs. Drain the water separator daily to maintain proper function.

To drain the water separator:

1. Loosen the valve on the bottom of the separator.
2. Retighten the valve once all of the water has been drained from the catch bowl.

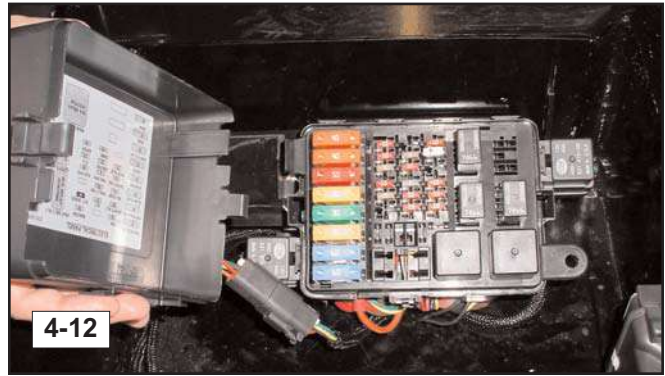

4-12

**Fuse Panel**

The electrical system in the Scout is equipped with fuses that protect the electrical components from damage. They can be found in the fuse panel located beneath the passenger seat.

In the event of an electrical malfunction, the most logical place to start is the fuse panel. Check the fuse(s) related to the problem you are having and inspect it. If the fuse filament appears broken, black or burned, it needs to be replaced. Replace fuses with the correct amperage replacement fuse only. Replacing a fuse with one of a higher amperage rating may burn out the electrical component the fuse was meant to protect. See the troubleshooting section of this manual for an additional resource to aid in tracking suspected electrical problems.

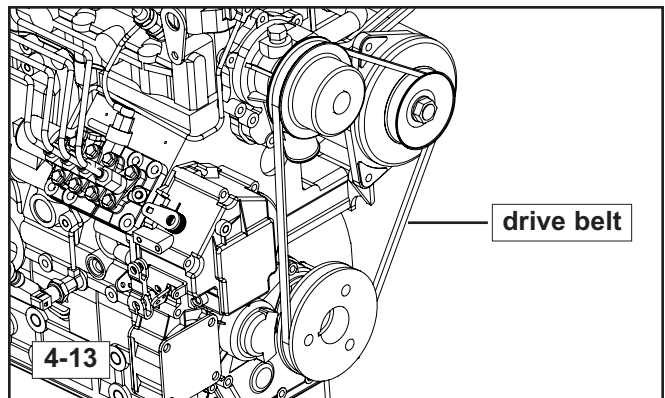

4-13

**Accessory Belts**

The engine uses a belt to drive accessories like the alternator, water pump, and cooling fan. Belts typically stretch and wear during their service life. As a result, the accessory belt on the Scout should be visually inspected daily for tension, condition, and presence prior to operating your machine.

To check drive belt:

1. With the engine off and cool, remove the key from the ignition to avoid accidental start.
2. Remove the engine cover from the machine.
3. Visually inspect the belt to make sure it is present, tight on the pulleys and in good condition.

**4. Maintenance**

**Engine Oil / Filter Change**

Regular oil changes are necessary to maintain a strong running engine. The normal interval between oil changes is 500 hours or one year. Machines that are operated under harsh conditions should have the oil and filter changed more frequently. ASV recommends an interval of 250 hours or six months for machines that are operated under these conditions. Harsh conditions may include: continuous high load applications, operation in high temperatures, or abnormally dusty, dirty conditions.

To change the oil and filter:

1. Start and warm the engine for a few minutes to warm the oil, then turn the engine off and remove the key from the ignition to avoid accidental start.
2. Remove the belly pan beneath the engine. (fig. 4-14)
3. Place a suitable container beneath the rear drain plug and filter to catch the used oil as it drains.
4. Remove the drain plug from the oil pan and allow the oil to drain completely from the engine. Use the correct size wrench to keep the plug in reusable condition. (fig. 4-15)
5. Remove the engine oil filter by hand or with a strap wrench if necessary. (fig. 4-16)
6. Once the filter has been removed make sure the old rubber gasket is present on the filter. If it is not on the old filter, check the filter head (engine). If it is still there, remove it prior to installing the new filter.

**NOTICE**

If the oil filter gasket (A) is not removed from the filter head and the new filter is installed on top of it, an oil leak will result when the engine is started. If unnoticed, the engine may run itself out of oil causing engine failure. (fig. 4-16)

7. Prepare the new filter for installation by rubbing fresh oil onto the exposed surface of the rubber filter gasket.
8. Thread the new filter onto the filter head. Tighten the filter by hand as instructed by the label located on the filter or filter box.
9. Re-install the drain plug and tighten to secure it in place.
10. Remove the oil filler cap and fill the engine crankcase with ASV Posi-Lube™ 10W-30 Heavy Duty Engine Oil. (capacity: 11.2 U.S. quarts including filter). (fig. 4-17)
11. Install the oil filler cap.
12. Perform a visual inspection to make sure the drain plug, filter, and oil filler cap are in place and tight.

13. Start the engine and watch the oil pressure indicator light in the warning light display. The light should come on, then go out when oil pressure has been achieved. If the light doesn't go out, turn the engine off immediately and look for potential problems. If the light does go out as expected, oil pressure has been achieved.

14. Once the engine is running, perform a visual inspection to make sure there are no leaks or other visible/audible problems.

15. If everything looks as it should, turn the engine off, reinstall the belly pans and perform the oil level check procedure on page 4-7.

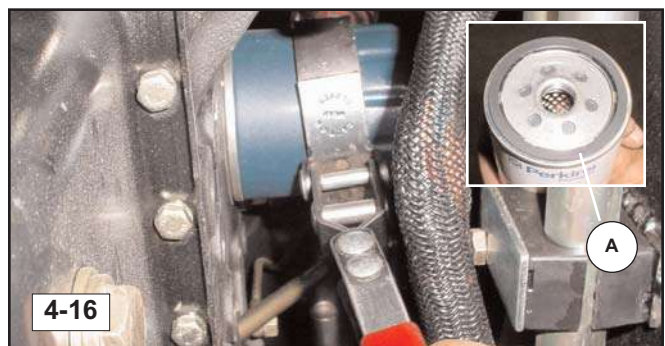

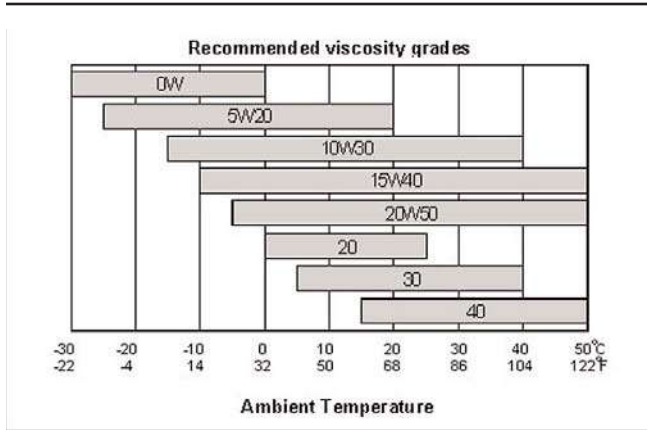

### Engine Oil Specifications

ASV recommends using Posi-Lube 10W-30 Heavy Duty Engine Oil for most conditions. In the event of an alternate working environment, the chart above may be used as a guide to oil viscosity grades.

You may also use a quality engine oil substitute meeting the following minimum specification:

- API CH-4 multigrade engine oil.

### Oil Level Check

To check the oil level:

1. Park the machine on level ground.
2. Remove the engine cover to gain access to the engine compartment.
3. Locate and remove the engine oil dipstick (B) from its tube.
4. Wipe the dipstick with a clean shop cloth and re-insert it into the tube until it comes to rest in its seated position.
5. Remove the dipstick once again and inspect the end for oil on the level indicator.
6. Oil should be present on the dipstick up to, but not over the upper (full) level indicator notch. If the level is correct, reinstall the dipstick and then reinstall the engine cover to complete the procedure.
7. If the level is low, add the proper grade and viscosity engine oil and re-check as necessary until the proper level has been achieved. Then re-install the dipstick and filler cap and install the engine cover to complete the procedure.

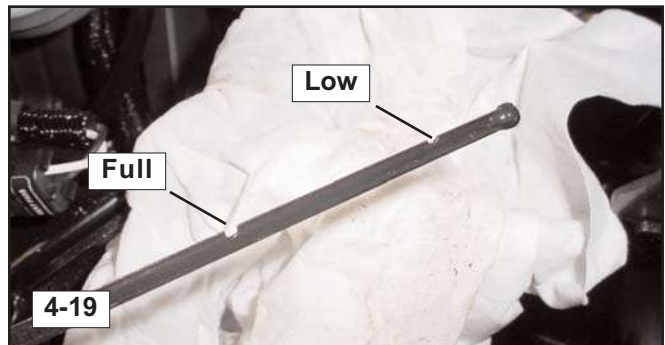
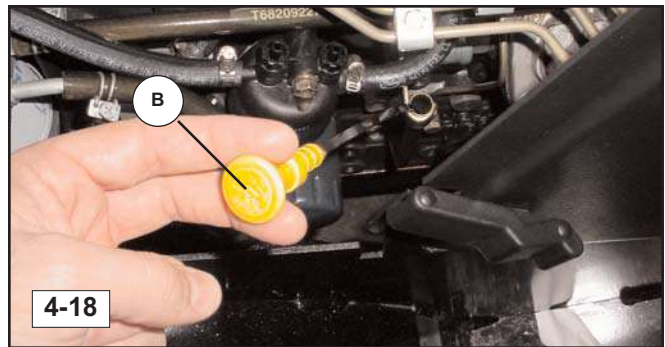

**4. Maintenance**

**Hydraulic Fluid / Filter Change**

Hydrostatic components require extremely clean oil in order to have a long service life. Use extreme caution when changing the hydraulic oil. Introducing dirt or debris could be detrimental to the hydraulic system. ASV recommends service intervals of 500 hours for hydraulic fluid and 250 hours for hydraulic filter.

**To change the hydraulic fluid:**

1. Remove the belly pan that mounts between the torsion axles to access the hydraulic tank drain.
2. Locate the hydraulic system drain in the center of the exposed portion of the tank just in front of the rear torsion axle.
3. Remove the drain plug using the correct size wrench to avoid damaging the plug. (fig. 4-20)
4. Drain the hydraulic fluid into a suitable catch container.
5. Remove access cover in the cargo bed behind the passenger seat to access the hydraulic reservoir. (fig. 4-21)
6. Locate the hydraulic filter housing beneath the access cover.
7. Thoroughly clean around the filter housing to prevent dirt or debris from entering the system.
8. Remove the bolts securing the filter housing cover to the housing, then remove the cover. (fig. 4-22)
9. Remove the filter from the housing and replace it with a new one. (fig. 4-23)
10. Reverse steps 3 and 8 to close the system.
11. Open the passenger side access door to the rear console enclosure (behind the seats) and remove the hydraulic oil filler cap. (fig. 4-24)
12. Fill the hydraulic system with ASV Posi-Lube Premium All Season MV Hydraulic Oil or equivalent until the full mark on the dip stick has been reached (fig. 4-24, 4-25).
13. Start the engine and operate the hydraulic circuits to work any trapped air out of the system.
  - Drive the machine forward and backward.
  - Turn the steering wheel left and right while in motion.

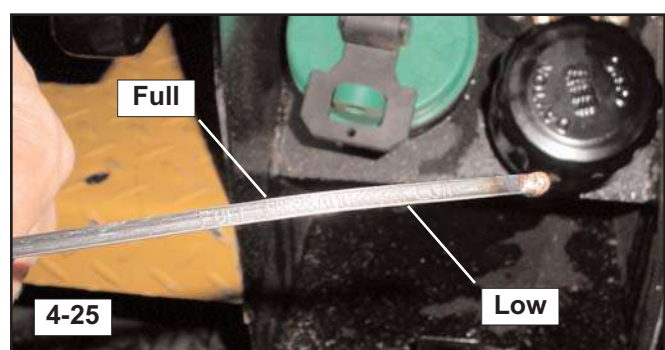
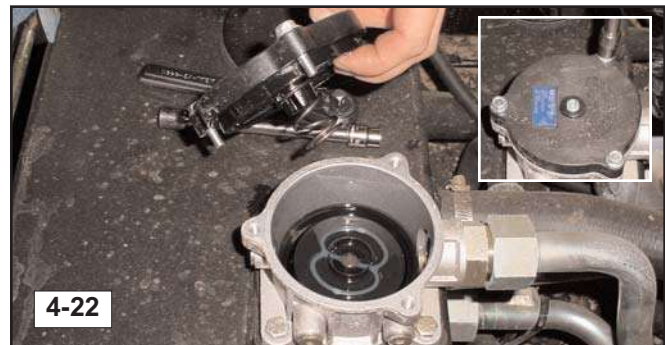
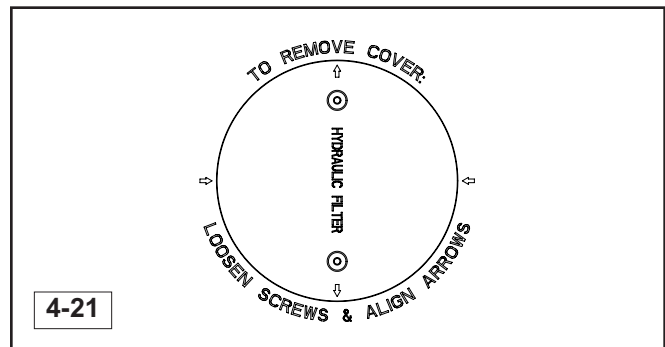

### Undercarriages

The undercarriage assemblies typically operate in harsh working conditions. They may work in mud, gravel, debris and various other abrasive materials during operation. ASV recommends a daily inspection of the undercarriage assemblies and cleaning if necessary.

Materials that are particularly sticky or abrasive like clay, mud, or gravel should be cleaned from the undercarriages more often to minimize component wear. A pressure washer works well for cleaning materials from the undercarriages. At times when a pressure washer is not available, use a bar, shovel or similar device to remove foreign materials.

When cleaning, pay particular attention to the drive motors/sprockets and the front wheels where debris is likely to accumulate. If traversing scrap or debris, inspect more often and remove foreign objects that may wrap around or lodge themselves between components causing premature wear and damage.

Operating in loamy sand or on turf or other finished surfaces may require less frequent cleaning, but daily inspection is still advised.

### Grease Fittings

The undercarriages are equipped with grease fittings at the main torsion axle pivot points. **Lubricate fittings daily or after every 10 hours of operation** to ensure proper operation and maximize component life.

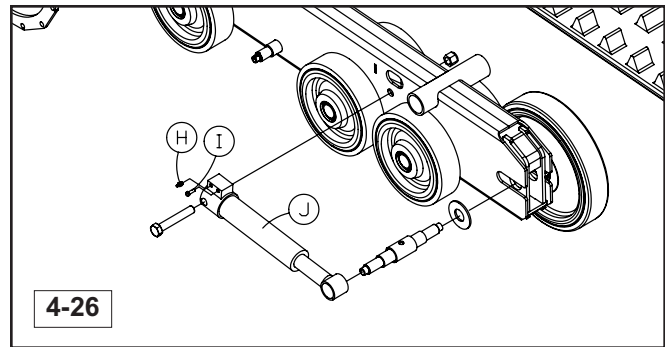

### Track Tension

Proper track tension must be maintained for optimal performance and track/undercarriage life. Running a track that is too loose may cause the track to misfeed, possibly causing damage to the track and/or undercarriage components. Running a track that is too tight may cause track stretch, premature bearing failure, or other preventable damage to the machine. Tracks should only be tightened to the point where there is no visible sag (when viewed from the side) between the rear sprocket and the front idler wheels. Never tighten the tracks beyond this point.

### Adjustment

To tighten tracks:

1. Locate the input grease zerk (H) on the tensioner unit (J) mounted within the frame rail. (fig. 4-26)
2. Connect a grease gun to the zerk and inject grease into the tensioner until the track is properly tensioned.

The track tension adjustment procedure is now complete.

If for some reason the tracks are too tight, loosen them until tension is correct.

To loosen tracks:

1. Locate the grease bleeder bolt (I) adjacent to the input zerk on the tensioner unit. (fig. 4-26)
2. Using a socket wrench and extension, loosen the bleeder bolt slowly until grease begins to flow out from around the bolt. Allow grease to bleed out until track tension is correct.

**Note:** During the first 50 hours of operation the tracks will "break-in" and will most likely require adjustment.

**4. Maintenance**

**Track Removal**

The rubber tracks may need to be removed periodically to inspect undercarriage components or for replacement if worn or damaged.

To remove tracks:

1. Raise the machine off of the ground and mechanically support it on ASV jack stands at a height that allows just enough clearance for track removal. The recommended distance is 3-4" from the bottom of the track to the ground.
2. Remove the outer snap ring and grease cover on the outer front 14" idler wheel (fig. 4-27, 4-28). Then remove the nut and washer from the axle. (fig. 4-29) Leave the wheel in place for now.
3. Loosen the bleeder bolt (I) on the grease tension unit (J) and allow grease to flow out until the front wheels are almost touching the 10" wheels behind them (fig. 4-26). Then tighten the bleeder bolt to hold them in place (fig. 4-30). This will put slack in the track and allow the two front 10" wheels to be removed (fig. 4-30).
4. Remove the two front 10" diameter wheels (second wheel back in the undercarriage from the front) by first removing the outer snap rings and grease covers, then remove the nuts securing the wheel assemblies to the axle (fig. 4-31, 4-32). Then remove the wheels (fig. 4-33, 4-34).

**Note:** A pry bar may be useful in helping to free the wheels from the axles for removal.

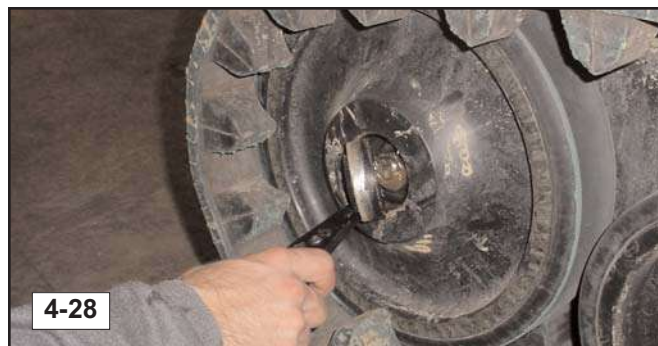

5. Loosen the bleeder bolt once again and move the front 14" wheels and axle as far rearward as possible. It may be necessary to assist in sliding the wheels rearward by stepping down on the inside of the track as shown (fig. 4-35).
6. Grab hold of the track and the outer front 14" wheel, then pull them off of the undercarriage together, from the inside to the outside of the machine (fig. 4-36).

---

**Note:** Keep the 14" wheel center in line with the axle as much as possible during wheel/track removal to avoid damaging the inner wheel seal as it passes over the threads on the axle shaft.

---

**Note:** The outer bearing on the 14" wheel will most likely fall out of the wheel as you remove it from the undercarriage. Make sure to remove it or catch it if possible to keep it clean (fig. 4-37).

---

7. Pull the track the rest of the way off of the under carriage at the rear of the machine (fig. 4-38).

Repeat this procedure if necessary on the other side of the machine.

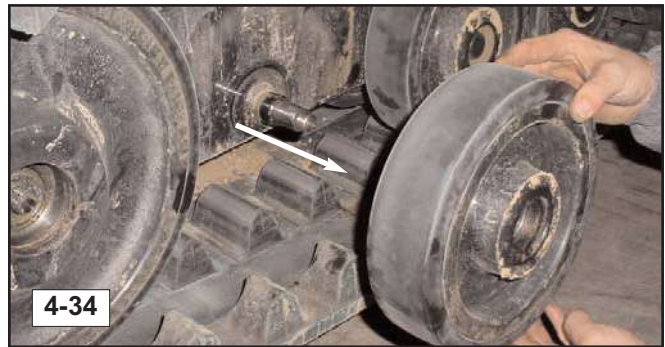



#### 4. Maintenance

##### To install tracks:

1. Wrap the track around the sprocket at the rear of the undercarriage (fig. 4-39).
2. Lubricate the inner front 14" wheel and the inside of the track at the front to aid in sliding the track back onto the undercarriage (fig. 4-40, 4-41). Wipe the axles clean (fig. 4-42).
3. Install outer 14" wheel into the track between the drive lug rows, then pull or pry the wheel forward to line it up with the axle, then slide it onto the axle as you slide the track over the inner 14" wheel. Once on the axle, tap the wheel gently inward into position (see note below) (fig. 4-42, 4-43).

**Note:** It is important to carefully align the wheel center with the axle prior to sliding it on to avoid damaging the inner seal during installation.

**Note:** If for some reason your machine is higher off of the ground than recommended, you may need to raise the lower portion of the track upwards towards the undercarriage in order to gain the slack needed to perform step 3.

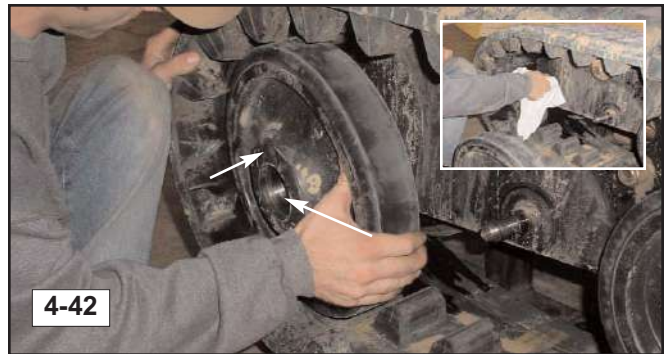
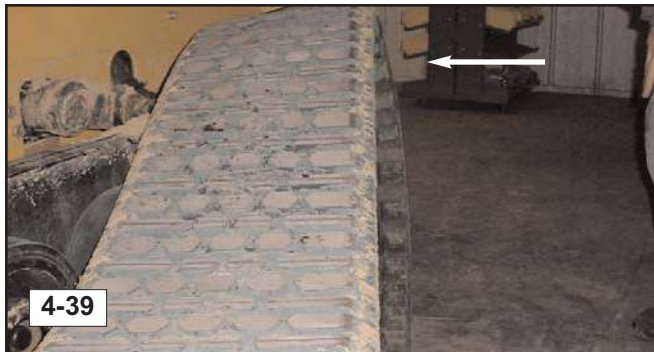

4. Clean and reinstall (repack with grease if necessary) the outer bearing into the 14" wheel (fig. 4-44).
5. Reinstall the washer and lock nut and tighten to secure the 14" wheel in place. Do not install the grease cover or snap ring yet (fig. 4-45, 4-46).

**Note:** The markings (indentations) on the lock nut face should be visible from the outside of the wheel during installation. This indicates proper orientation of the nut on the axle.

6. Tighten the bleeder bolt and attach a grease gun to the input zerk. Pump grease into the tensioner unit until the 14" wheel is just far enough forward to install the 10" wheel (fig. 4-47).
7. Install the inner and outer 10" wheels and secure them in position with their nuts, grease covers and snap rings (fig. 4-48, 4-49).
8. Attach a grease gun to the input zerk and pump grease into the tensioner unit until there is no visible sag in the track when viewed from the side (fig. 4-50).
9. Retighten the nut on the outer 14" wheel, then install the grease cover and snap ring (fig. 4-51, 4-52).

Repeat this procedure if necessary on the other side of the machine.

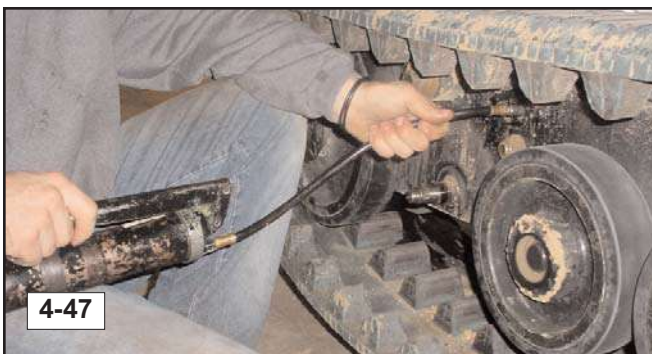

4. Maintenance

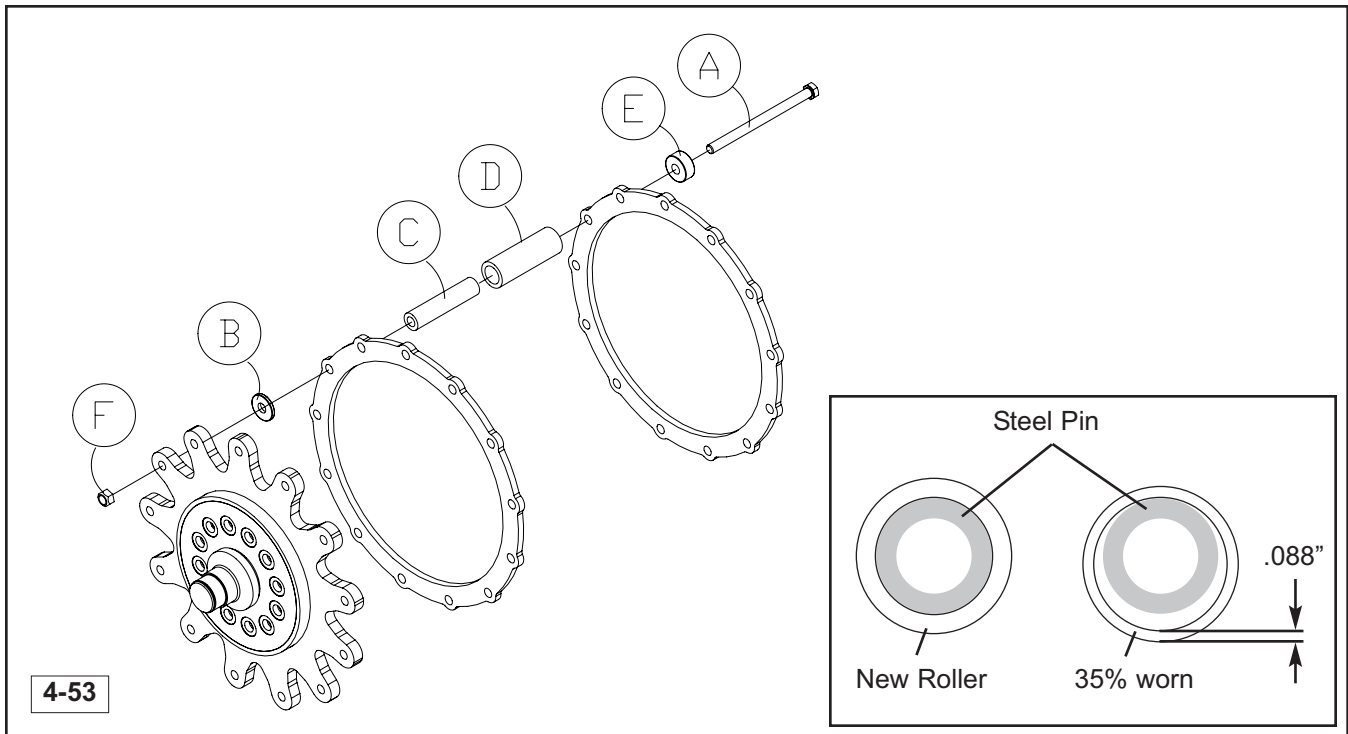

4-53

**Drive Sprocket Rollers**

ASV undercarriages utilize rollers on the drive sprockets to drive the track. These rollers help minimize friction between the track and the drive sprocket to prolong track life. The rollers rotate around hardened steel pins and usually wear on their inside surfaces.

As they wear, the rollers become thinner, but will continue to function as long as they rotate freely around the pins.

Sprocket rollers should be inspected every 50 hours of operation and replaced if cracked or worn to less than 35% of original thickness. (.088")

**Roller Replacement**

Turn the engine off, remove the key from the ignition and disconnect battery prior to performing this procedure.

To replace worn rollers:

1. With the machine turned off and parked in a safe working area, remove the track to expose the sprocket for roller replacement. (see page 4-10)
2. Remove one bolt (A) holding washer (B), steel pin (C), roller (D), and external roller (E) in place. The pin and roller may then be removed from the sprocket. (fig. 4-53)
3. Install a new roller over the pin.
4. Slide the bolt back through the sprocket, washer, pin, and external roller. (fig. 4-53)
5. Install and tighten the retaining nut (F).

6. Repeat this procedure as required throughout the sprocket.
7. Reinstall the track. (pg. 4-12)
8. Repeat this procedure on the other side of the machine if necessary.
9. Perform the track tension adjustment procedure. Roller replacement is now complete.

**Note:** ASV recommends replacing external rollers as a set to simplify inspection and maintain proper sprocket function.

**Note:** Internal pins should be inspected when replacing rollers. Internal pins do not rotate during operation and may experience uneven wear. Replace if worn to less than 35% of original thickness.

# 5. Machine Controls and Instrumentation

## Chapter Overview

This chapter contains an overview of the machine controls and instrumentation. For further information regarding machine controls, instrumentation or operation, refer to the operation and maintenance manual for the SC-50. Included here are illustrations of the following controls and instrumentation components and a description of their functions.

- Machine Controls
- Instrumentation (Location and Function)
- Switches (Location and Function)

## Machine Controls (fig. 5-1)

There are three main machine controls: Steering control (1), directional speed control (2), and throttle (3).

### Steering Control

The steering control (1) is a wheel that allows the operator to turn the machine to the left or right while the machine is in motion.

### Directional Speed Control

The directional speed control (2) allows the operator to control the direction and speed of machine motion.

### Throttle

The hand throttle (3) controls engine rpm.

### Attachment Control

The attachment control (4) controls intermittent auxiliary hydraulic function.

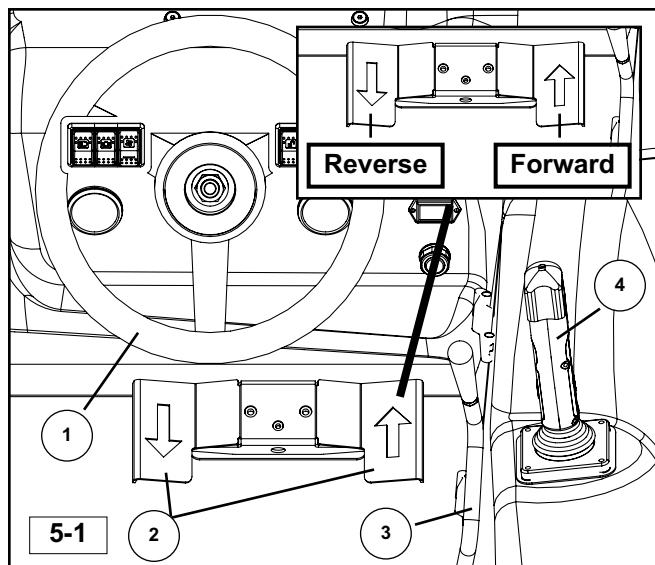

## Instrumentation

The Instruments (Figure 5-2, 5-3) are positioned in the dash panel for good visibility when seated inside the operator enclosure. Instruments include the following components.

- (1) Fuel Level Gauge (fig. 5-2)
  - High Range Indicator
  - Glow Plug Operation Indicator
- (2) Warning Light Display (fig. 5-3)
  - Oil Pressure Warning Light
  - Coolant Temp. Warning Light
  - Hyd. Oil Temp. Warning Light
  - Battery Voltage Warning Light

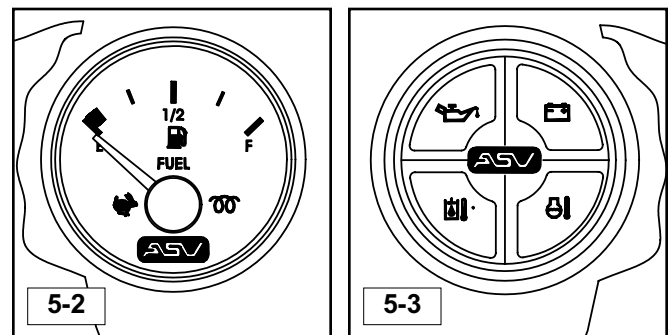

### NOTICE

If the engine coolant temperature, engine oil pressure or hydraulic oil temperature lights illuminate during normal machine operation, shut the machine down immediately. Diagnose the problem and make any necessary repairs before resuming operation.

### NOTICE

If the battery low-voltage light illuminates, drive the machine to a suitable location and shut the engine off. Diagnose the problem and make any necessary repairs before resuming operation.

The glow plug operation light illuminates only when the key switch is turned to engine pre-heat, showing normal operation.

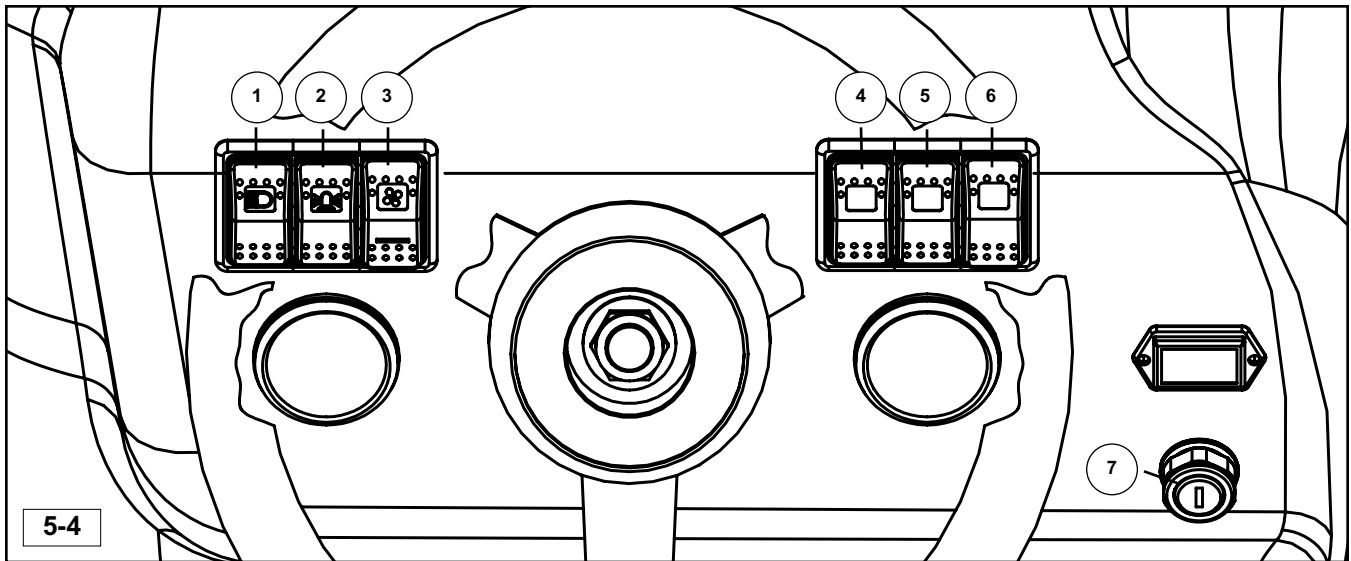

## Switches

The various switches (Figure 5-4) are positioned to provide good access and visibility. The switches are listed below.

### Switch Panels

1. Headlight Activation Switch
2. Beacon Activation Switch\*
3. Heater Fan Activation Switch\*
4. Push To Operate Switch
5. 2-Speed Activation Switch
6. Continuous Flow Auxiliary Hydraulic Switch\*
7. Ignition Switch

Optional equipment is indicated by an \*.

# 6. Operator Enclosure

## Chapter Overview

This chapter provides information on the assembly and disassembly of the operator enclosure assembly. If there is an issue that requires troubleshooting, refer to Chapter 15, Troubleshooting.

## Personal Safety

### **!WARNING!**

Improper or incomplete maintenance/repair of a Rubber Track Utility Vehicle can be dangerous and may result in machine damage, injury or even death.

Do not attempt to perform repair or maintenance on a Rubber Track Utility Vehicle until you have read and fully understood the information in this manual.

Refer to the Operation and Maintenance manual for instructions regarding proper machine operation techniques before operating any Rubber Track Utility Vehicle.

Prior to performing any type of service work on a Rubber Track Utility Vehicle, read and understand Chapter 1 (Product Safety) for personal safety information.

## Machine Preparation

### **!WARNING!**

Accidental machine starting can cause injury or even death to personnel working on a Rubber Track Utility Vehicle.

As a precaution, disconnect the battery cables from the battery terminals, tape the battery clamps and remove the key from the ignition switch prior to performing any service work on a Rubber Track Utility vehicle.

Place a "Do Not Operate" tag prominently on the machine to inform personnel that the machine is being worked on.

## Removal and Installation

Removal and installation procedures are provided for the following operator enclosure components.

- Seat & Operator Presence (Seat) Switch
- Switches
- Front Fascia
- Gauges & Hour meter
- Engine Cover
- Steering Wheel & Mechanism
- Dash panel

**Note:** Procedures are provided for only the operator enclosure components listed above. However, exploded parts diagrams exist in the SC-50 parts manual to serve as visual aids in the removal or installation of other operator enclosure components.

## Seat

### Removal

<b>Required Tools</b>
-----------------------

<b>Combination/Socket Wrenches</b>
------------------------------------



1. Press down to release the seat latch . (fig. 6-1)
2. Rotate the seat forward as shown to expose the mounting bolts and retaining nuts. (fig. 6-1)

## 6. Operator Enclosure



3. Remove the 4 nuts securing the seat to the mounting panel. (fig. 6-2)



4. Unplug the seat harness from the machine as shown. (fig. 6-3)



5. Remove the seat from the machine. (fig. 6-4)
6. Repeat steps 1-5 on the passenger side to remove the other seat if necessary.

### Installation

1. To reinstall the seat(s), reverse the removal procedure.

## Seat Switch

### Removal

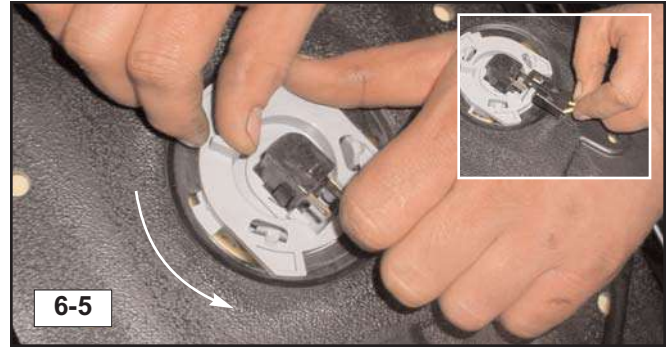

1. Disconnect the seat switch harness from the switch, then twist the switch assembly counter-clockwise as shown to remove it from the underside of the seat. (fig. 6-5)

**Note:** If the seat switch harness needs to be removed, you must first remove the seat track that it passes under. The harness may then be removed.

### Installation

1. To reinstall the seat switch, reverse the removal procedure.

## Switches

### Removal

Required Tools
Phillips Type Screwdriver



1. Remove the screws securing the driver's front intake screen, then remove the screen. (fig. 6-6)

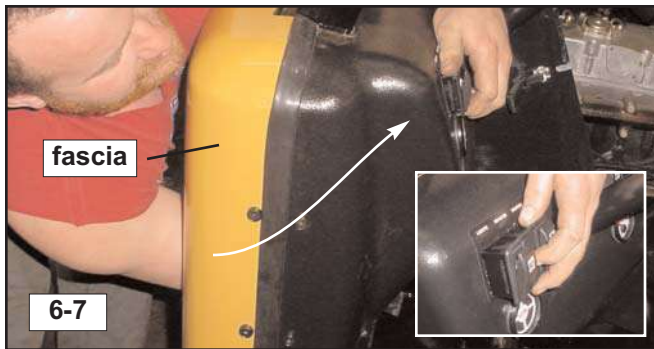

2. Reach through from the front of the machine and squeeze the top and bottom of each switch as close to the dash as possible to release the clips that secure them, then push them through dash slightly as shown. Unplug the connectors as necessary, then remove the switches (fig. 6-7)
3. If necessary, remove the other switches in this same manner.

**Note:** It is not necessary to remove the front fascia to remove these switches, however, if you have difficulty removing them in this time saving manner, it may be wise to remove the front fascia to access them.

### Installation

1. To reinstall the switches into the dash panel, reverse the removal procedure.

## Front Fascia Removal

### Required Tools

Allen (hex) wrenches



1. Remove the front fascia by first removing the retaining screws securing the perimeter. Then lift and remove the fascia. (fig. 6-8)

### Installation

1. To reinstall, reverse the removal procedure.

## Gauges & Hour Meter Removal

### Removal

#### Required Tools

Socket/Combination Wrenches

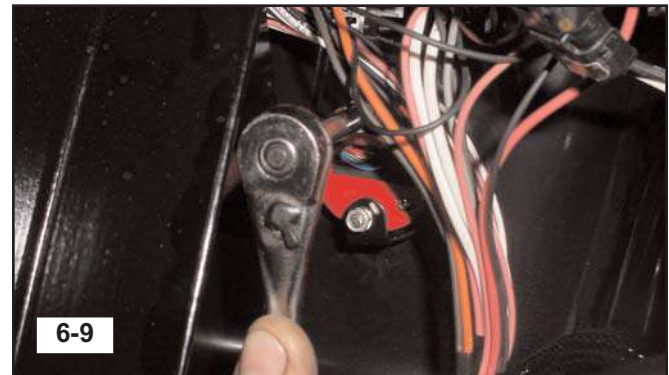

1. Remove the front fascia from the machine to access the gauges. Locate the retaining nuts and remove them. (fig. 6-9)



2. Disconnect the gauges from the wiring harness, then remove them from the dash. (fig. 6-10)



3. To remove the hour meter, remove the two screws holding it in place, then disconnect it from the wiring harness and remove as shown. (fig. 6-11)

### Installation

1. To reinstall, reverse the removal procedure.



## Engine Cover

### Removal



1. Disconnect the rubber straps securing the cover to the chassis. (fig. 6-12)



2. Remove the drink tray by twisting the latch mechanism, then remove. (fig. 6-13)



3. If the machine is equipped with auxiliary hydraulics, you must disconnect the joystick from the machine wiring harness as shown. (fig. 6-14)



4. Lift and remove the engine cover from the machine. (fig. 6-15)

### Installation

1. To reinstall the engine cover, reverse the removal procedure.

## Steering Wheel & Mechanism

### Removal

#### Required Tools

Socket/Combination Wrenches  
Blade Type Screwdriver  
Hammer & Brass Drift

1. Remove the front fascia as described on page 6-3.

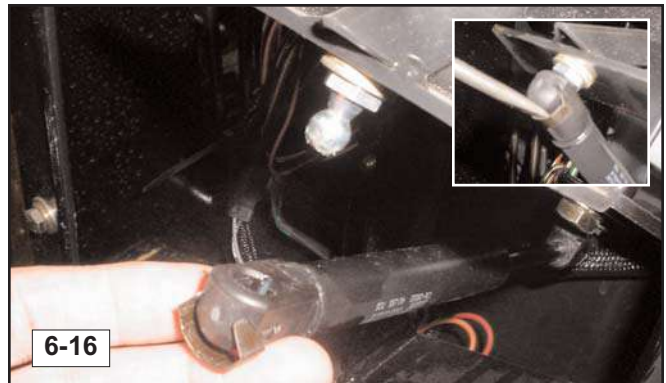

2. Pry the clip away from the ballstud, then pull the gas spring away as shown. Repeat on the other end of the gas spring to remove. (fig. 6-16)

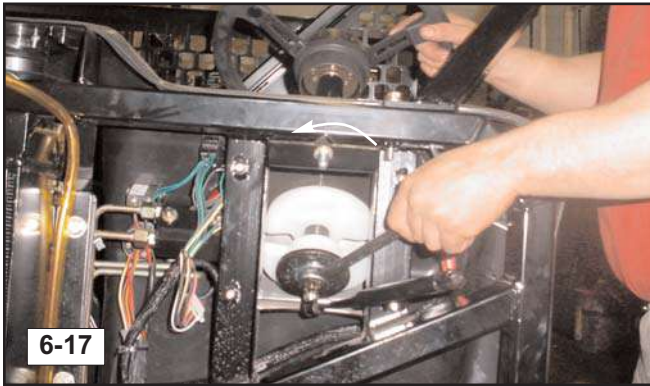

3. Loosen the bolt securing the steering components to the steering shaft as shown. (fig. 6-17)



4. Gently tap the end of the bolt until the lower retaining plate comes loose and slides down on the bolt. (fig. 6-18)

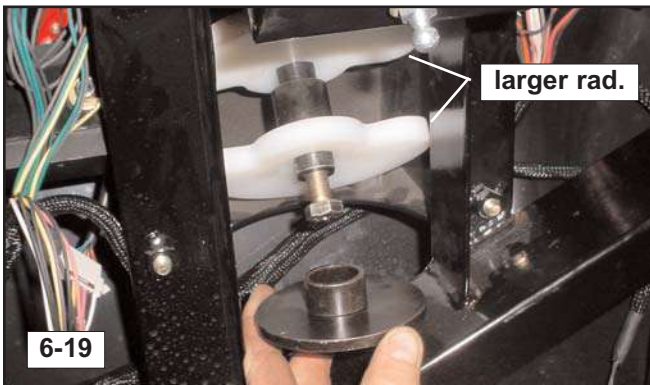

5. Once the components are loose and begin sliding down, remove the bolt so that the end cap can be removed, then slide everything down off of the steering shaft. (fig. 6-19, 6-20, 6-21)

**Note:** Note the order and orientation of the steering components as you remove them. Label them if necessary. The plastic steering cams are identical to each other, but each has a bigger radius on one end of the arc than on the other. They need to be installed correctly in order to function properly.

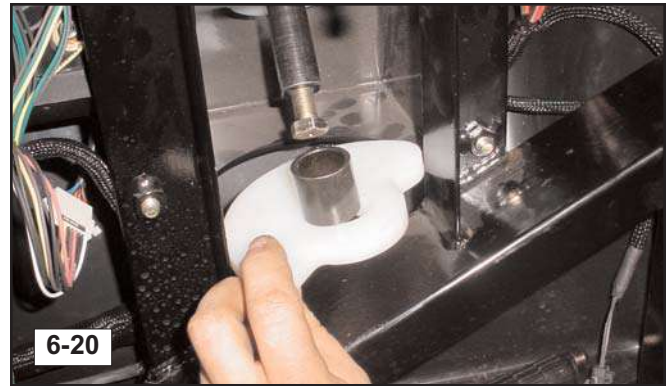

6. Once all of the components are off of the lower portion of the shaft, slide it out through the top with the bushing as shown. If necessary reinstall the lower bolt and tap it gently to get it to slide upward out of the lower bushing. (fig. 6-22)

**Note:** The steering bushings are now accessible for replacement if necessary.

**Note:** The steering wheel may be removed at any time by removing the center cover and removing the retaining nut. You may need to reinstall the nut loosely and tap it to release the wheel from the shaft. (fig. 6-22)

## 6. Operator Enclosure

- Once the internal steering components have been removed, remove the dash panel according to the procedure on this page.

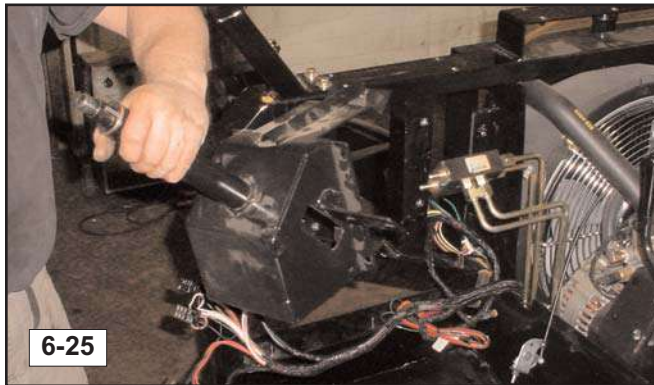
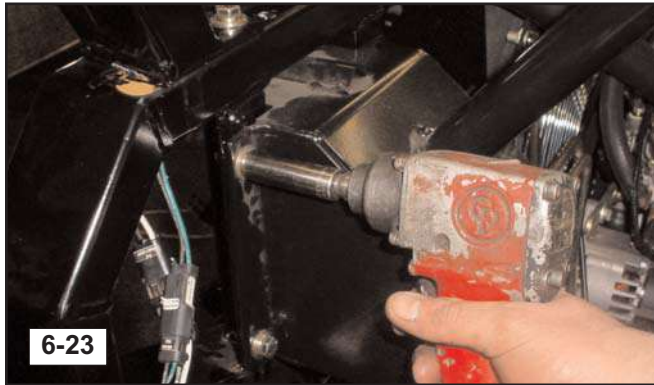

- Remove the bolts securing the steering bracket weldment to the chassis. Then remove the bolts securing the steering valve to the bracket. Once all bolts have been removed, lift and remove the bracket from the machine. (fig. 6-23, 6-24, 6-25)

### Installation

- To reinstall the steering components, reverse the removal procedure.

## Dash Panel

### Removal

#### Required Tools

Combination Wrenches  
Blade/Phillips Type Screwdriver  
Hex (Allen) Wrenches



- If your machine is equipped with a heater, disconnect the duct hoses from the vent openings by loosening the clamps and pulling them off as shown. (fig. 6-26)

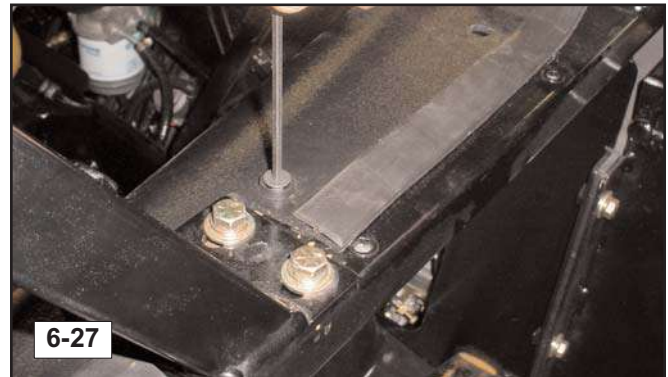

- Remove the screws securing the dash panel to the chassis. There are screws located in the top, sides, and underneath the dash panel. (fig. 6-27, 6-28)

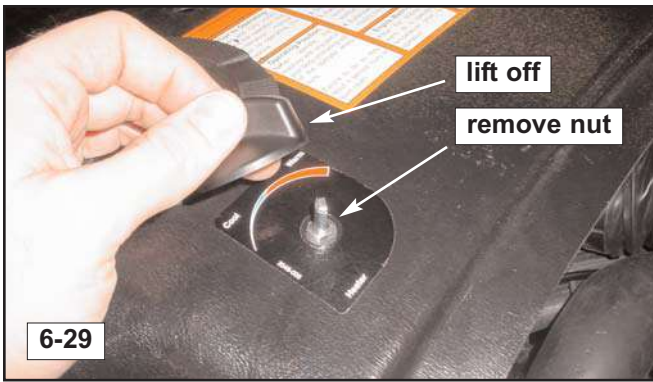

3. If your machine is equipped with a heater, lift the heater control knob from the cable mechanism, then remove the retaining nut that secures the cable mechanism to the dash. (fig. 6-29)



4. Slide the mechanism down and out of the mounting hole in the dash panel, then lay it aside. (fig. 6-30)



5. Lift and remove the dash panel from the machine. (fig. 6-31)

#### NOTICE

Make sure that all gauges, switches, meters, etc. are disconnected from the machine wiring harness before lifting the dash panel out of the machine. Pulling these apart forcefully will most likely cause damage and require costly repairs.

#### Installation

1. To reinstall the dash panel, reverse the removal procedure.

**Intentionally left blank**

# 7. Chassis and Fuel Tank

## Chapter Overview

This chapter provides information on the assembly and disassembly of the chassis. If there is an issue that requires troubleshooting, refer to Chapter 15, Troubleshooting.

## Personal Safety

### !WARNING!

Improper or incomplete maintenance/repair of a Rubber Track Utility Vehicle can be dangerous and may result in machine damage, injury or even death.

Do not attempt to perform repair or maintenance on a Rubber Track Utility Vehicle until you have read and fully understood the information in this manual.

Refer to the Operation and Maintenance manual for instructions regarding proper machine operation techniques before operating any Rubber Track Utility Vehicle.

Prior to performing any type of service work on a Rubber Track Utility Vehicle, read and understand Chapter 1 (Product Safety) for personal safety information.

## Machine Preparation

### !WARNING!

Accidental machine starting can cause injury or even death to personnel working on a Rubber Track Utility Vehicle.

As a precaution, disconnect the battery cables from the battery terminals, tape the battery clamps and remove the key from the ignition switch prior to performing any service work on a Rubber Track Utility Vehicle.

Place a "Do Not Operate" tag prominently on the machine to inform personnel that the machine is being worked on.

## Removal and Installation

Removal and installation procedures are provided for the following chassis components.

- Hand Throttle Assembly
- Cargo Bed
- Fuel Sending Unit
- Fuel Tank
- R.O.P.S. Rollcage
- Rear Console
- Torsion Axles (undercarriages)

**Note:** Procedures are provided for only those chassis components listed above. However, exploded parts diagrams exist in the SC-50 Parts manual to serve as visual aids in the assembly and disassembly of other chassis components.

## Hand Throttle Assembly

### Removal

#### Required Tools

Screwdriver  
Combination/Socket Wrenches  
Hex (Allen) wrenches

1. Remove the engine cover as described on page 6-4 of this manual.

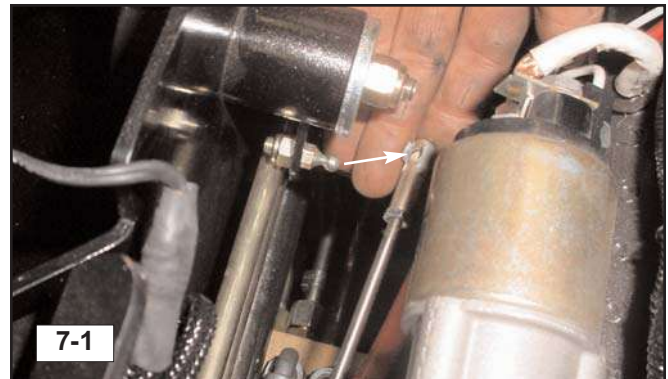

2. Disconnect the throttle cable from the throttle lever arm located just inside the chassis beneath the throttle lever pivot point. (fig. 7-1)

Rubber Track Utility Vehicle  
7. Chassis and Fuel Tank



3. Loosen and remove the retaining bolt and nut along with the internal components of the throttle assembly. (fig. 7-2)

**Note:** Note the order of the components during disassembly to aid during reassembly.

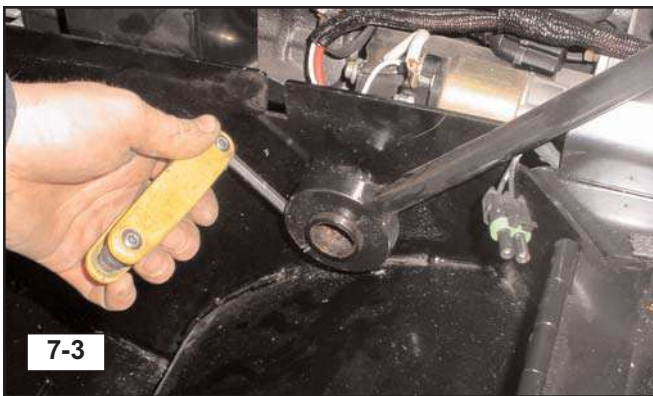

4. Loosen the pinch bolt securing the lever to the pivot. (fig. 7-3)



5. Slide the lever off of the pivot as shown. It may be helpful to use a penetrating lubricant and a rubber mallet to ease it off of the pivot. (fig. 7-4)

6. Disconnect the battery cables from the battery.

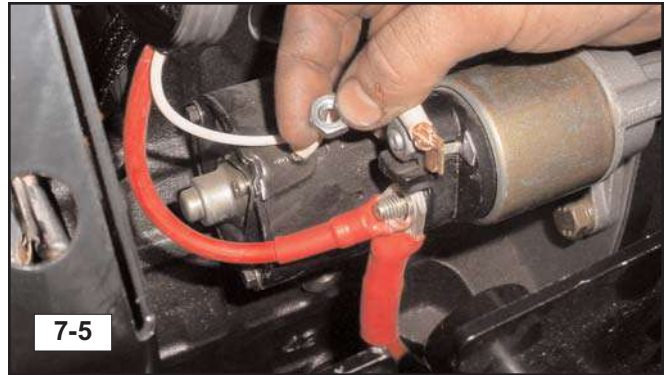

7. Once the battery has been disconnected, remove the various leads attached to the starter solenoid. Take note and label if necessary the leads and where they attach to the solenoid to aid during reassembly. (fig. 7-5)



8. Remove the bolts securing the starter to the engine as shown, then remove the starter from the machine. (fig. 7-6, 7-7)

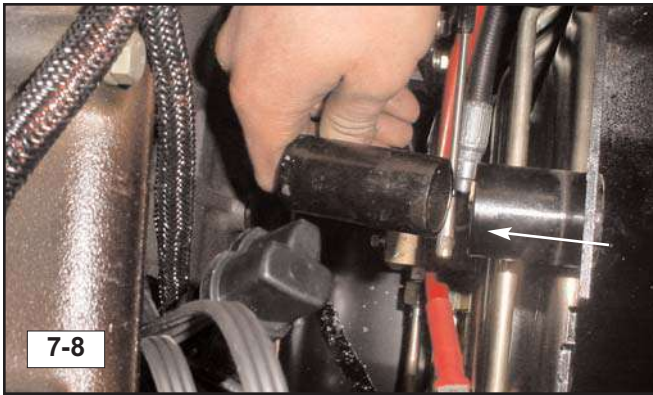

9. Now that the starter has been removed, there is clearance to remove the throttle pivot. Slide it out towards the engine and remove. (fig. 7-8)

### Installation

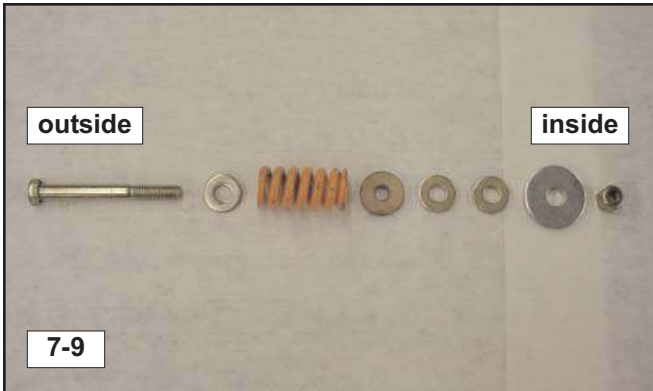

1. To install the throttle lever assembly, reverse the removal procedure.

**Note:** Figure 7-9 has been included to show the order of assembly for the internal components of the throttle. Please use this figure as a reference to ensure correct assembly during throttle installation.

## Cargo Bed Removal

### Required Tools

Combination/Socket Wrenches



1. Remove the retaining nuts securing the cargo bed sides to the cargo bed, then remove both sides. (fig. 7-10)



2. Remove the bolts securing the cargo bed to the chassis as shown. (fig. 7-11)



3. Have an assistant help you to remove the cargo bed from the machine. (fig. 7-12)

### Installation

1. To install the cargo bed, reverse the removal procedure.



## Fuel Sending Unit Removal

<b>Required Tools</b>
<b>Combination/Socket Wrenches</b>
<b>Screwdrivers (Blade and Phillips)</b>

1. Remove the cargo bed as described on page 7-3 to access the fuel tank and sending unit.



2. Disconnect the leads from the sending unit as shown. Note the position of the leads on the terminals to ensure correct assembly when reinstalling the unit. (fig. 7-13)



3. Loosen the clamps securing the fuel lines to the sending unit, then disconnect them and lay them aside. Again, note the size and position of the lines to ensure correct reassembly. (fig. 7-14)



4. Remove the screws securing the sending unit to the fuel tank. (7-15)



5. Remove the sending unit from the fuel tank. (7-16)

**Note:** There is a metal weight on the pickup tube that keeps the tube on the bottom of the tank. Now is a good time to inspect the tubing and make sure the weight is still in place as intended.

## Installation

1. To install the fuel sending unit, reverse the removal procedure.

## Fuel Tank Removal

<b>Required Tools</b>
<b>Combination/Socket Wrenches</b>
<b>Screwdrivers (Blade and Phillips)</b>

1. Remove the cargo bed as described on page 7-3 to access the fuel tank. Also, remove the rear belly pan to access the fuel tank drain plug.



2. Locate the fuel tank drain plug on the bottom of the tank. Remove it to drain the fuel into a suitable catch container. (fig. 7-17)

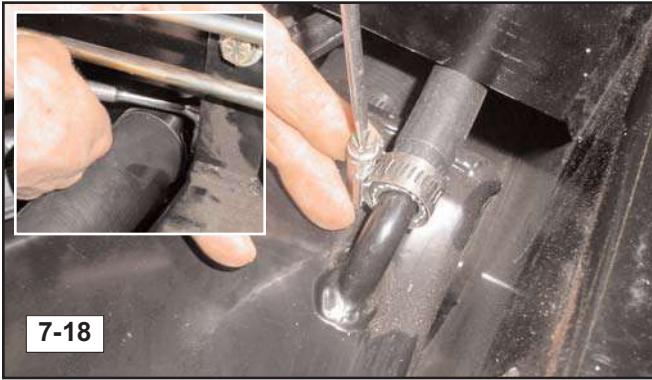

3. Loosen the clamps, then disconnect the vent and filler hoses from the fuel tank as shown. Lay them aside. (fig. 7-18)
4. Disconnect the wires connected to the fuel sending unit as described on page 7-4.



5. Remove the bolts securing the fuel tank to the chassis. (fig. 7-19)



6. Have an assistant help you to remove the tank from the machine. (fig. 7-20)

### Installation

1. To install the fuel tank, reverse the removal procedure.

### R.O.P.S. Roll cage Removal

#### Required Tools

Combination/Socket Wrenches  
Screwdriver (Phillips)



1. Remove the screws securing the driver's front intake screen, then remove the screen. (fig. 7-21)



2. Disconnect the two front left R.O.P.S. wire harness connectors from the main harness. These are located behind the front fascia and may be accessed through the left front intake grill removed in step 1. (fig. 7-22)



3. Disconnect the two left rear R.O.P.S. connectors from the main harness as well. They are located inside the drivers side access door just behind the seat. (fig. 7-23)



4. Remove the four bolts securing the front legs of the rollcage to the chassis. (fig. 7-24)



5. Remove the bolts securing the rear of the rollcage to the chassis. (fig. 7-25)



6. Lift and remove the R.O.P.S. rollcage from the machine. Make sure to carefully thread the wires and connectors (disconnected in steps 2 and 3) out of the chassis before completely removing the rollcage to prevent damage to those harnesses. (fig. 7-26)

### Installation

1. To install the R.O.P.S. rollcage, reverse the removal procedure.

### Rear Console Removal

#### Required Tools

Combination/Socket Wrenches  
Screwdriver (Blade/Phillips)

1. Removal of the rear console requires the removal of the engine cover, R.O.P.S., cargo bed, battery, air cleaner, and heater (if equipped) assemblies. Please refer to the appropriate sections of this manual for direction in the removal of these prior to attempting to remove the rear console from the machine.
2. Drain the hydraulic oil from the tank until the level is below the dipstick tube. See page 4-8 of this manual for detailed instructions.



3. Once the above components have been removed, disconnect the fill and vent tubes (including the hydraulic oil dipstick tube) from the various components within the machine to allow removal of the rear console. (fig. 7-27)

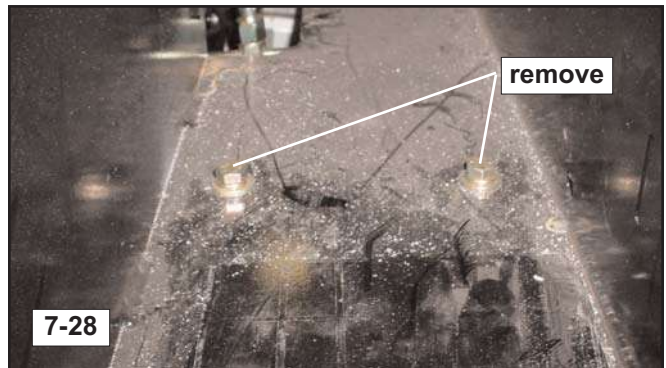

4. Remove the bolts securing the rear console to the chassis. If the machine is equipped with a heater, remove the heater support brackets from the machine as well. (fig. 7-28)

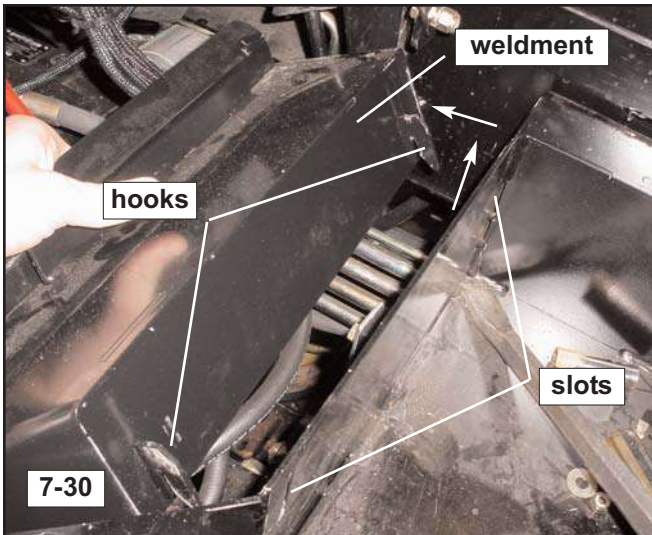

5. Once all bolts have been removed, all harnesses disconnected, all tubes disconnected, have an assistant help you lift the console up and out of the chassis. (fig. 7-29, 7-30) **(see note prior to performing this step)**

**Note:** There are two small weldments that attach (hook) under the seats (one on each side of the engine compartment) and add to the flat area the seat mounting plates seal against. These will interfere with the console as it is being removed. However, if you try to remove them by themselves, the console will interfere. So, you must tap them upward with a rubber mallet and remove them **as** the console is being lifted out. Rotate the seats forward or remove them by removing the three bolts securing the seat mounting plate (at the hinge) to the chassis. This will allow access to the weldments for removal. It may be wise to have a couple of helpers nearby to assist with this procedure.

Also, take care not to damage the hydraulic oil dipstick tube as this may catch on other tubes or hoses as you remove the console.

### Installation

1. To install the rear console, reverse the removal procedure.

## Torsion Axles (undercarriages)

### Removal

#### Required Tools

Hydraulic jack (rolling style)

Combination/Socket Wrenches

1. Raise and support the Scout on jack stands according to the jacking procedure on page 4-2 of this manual.
2. Remove the cargo bed according to the procedure on page 7-3 of this manual.
3. Drain the hydraulic fluid according to the procedure on page 4-8 of this manual.

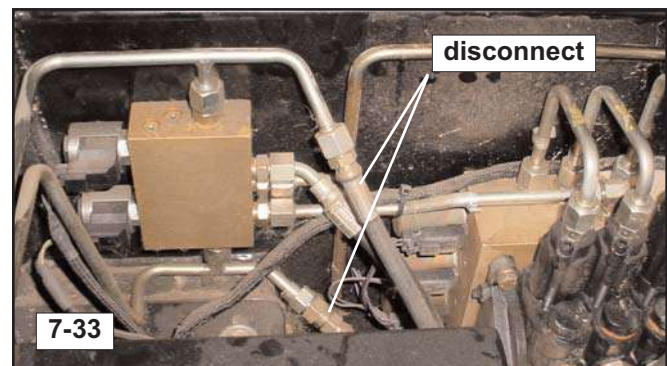
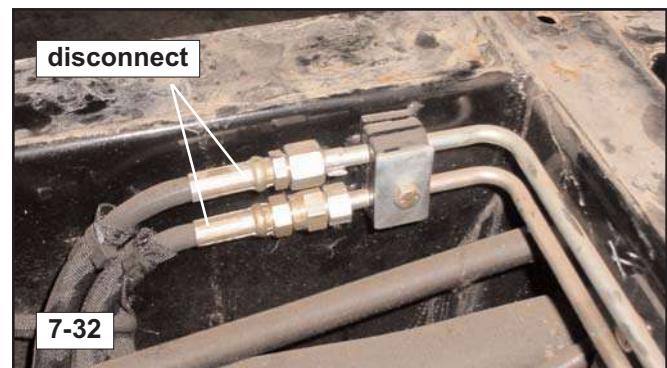
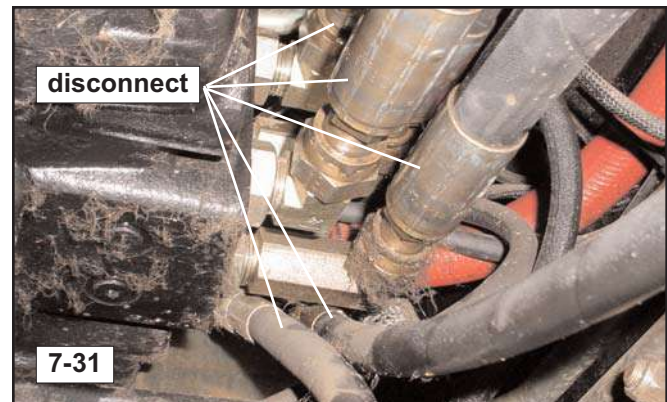

4. Disconnect the drive, case drain, and two speed/brake hoses from their connection points within the machine noting each connection point for reassembly. (fig. 7-31 through 7-33)

## 7. Chassis and Fuel Tank

---

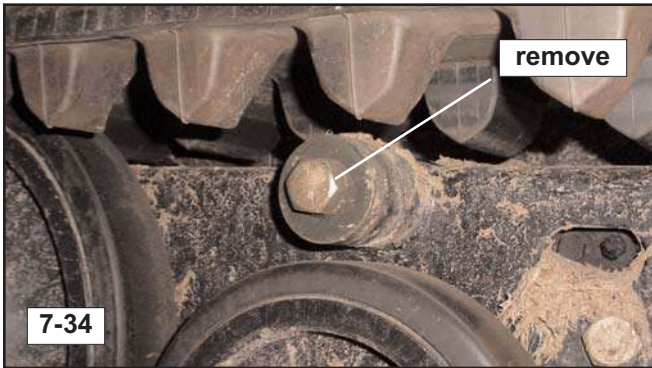

5. Remove the bolts securing the undercarriages to the torsion axles. (fig. 7-34)
6. Support the undercarriages with a forklift or hydraulic jacks (rolling style), then slide them off of the axles. Guide the hoses out of the chassis as you remove the undercarriages from the machine.

---

**Note:** Grease the axles thoroughly prior to removing the undercarriages from the machine. Also, If movement is difficult, it may be helpful to use a port-a-power to help push them off of the axles while supporting the weight with a forklift or rolling hydraulic jacks.

---



7. Support the weight of each axle with a hydraulic jack, then remove the bolts securing it to the chassis. (fig. 7-35)
8. Once all bolts have been removed, lower each axle to the ground and remove it from the machine.

### Installation

1. To install the torsion axles, reverse the removal procedure.

# 8. Radiator and Oil Cooler

## Chapter Overview

This chapter provides information on the disassembly and assembly of the radiator/oil cooler and associated components. If there is an issue that requires troubleshooting, refer to chapter 15, Troubleshooting.

## Personal Safety

### !WARNING!

Improper or incomplete maintenance/repair of a Rubber Track Utility Vehicle can be dangerous and may result in machine damage, injury or even death.

Do not attempt to perform repair or maintenance on a Rubber Track Utility Vehicle until you have read and fully understood the information in this manual.

Refer to the Operation and Maintenance manual for instructions regarding proper machine operation techniques before operating any Rubber Track Utility vehicle.

## Machine Preparation

### !WARNING!

Accidental machine starting can cause injury or even death to personnel working on a Rubber Track Utility Vehicle.

As a precaution, disconnect the battery cables from the battery terminals, tape the battery clamps and remove the key from the ignition switch prior to performing any service work on a Rubber Track Utility Vehicle.

Place a "Do Not Operate" tag prominently on the machine to inform personnel that the machine is being worked on.

Prior to performing any type of service work on a Rubber Track Utility Vehicle, read and understand Chapter 1 (Product Safety) for personal safety information.

## Removal and Installation

Removal and installation procedures are provided for the following radiator/oil cooler components.

- Radiator/Oil Cooler
- Fan, Spacer and Shroud/guard

**Note:** Procedures are provided for only those radiator/oil cooler components listed above. However, exploded parts diagrams exist in the SC-50 Parts manuals to serve as visual aids in the assembly and disassembly of other system components.

**Note:** Refer to page 3-2 for pictorial views of the hydraulic oil and engine cooling system components.

## Radiator/Oil Cooler

### Removal

#### Required Tools

Socket/Combination Wrenches
Pliers
Screwdriver
Hydraulic Caps/Plugs (various sizes)

### !WARNING!

Personal injury can result from exposure to hot fluids and components. Allow the machine to cool thoroughly before attempting any type of service on the cooling or hydraulic systems.

### !WARNING!

Cooling system conditioner contains alkali. Avoid contact with skin and eyes.

### NOTICE

Collect and contain liquids in suitable containers. Dispose of all liquids according to local regulations and mandates.

1. Remove the front fascia according to the procedure on page 6-3.



2. Make sure the machine has cooled thoroughly, then remove the radiator cap and drain the fluid from the radiator through the small drain valve located on the lower left side of the radiator when viewed from the operator's perspective. (fig. 8-1)

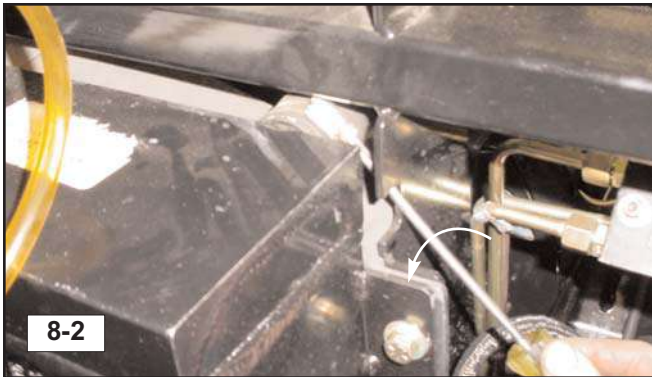

3. Loosen the clamps securing the coolant hoses to the radiator, then disconnect the hoses from the radiator. (fig. 8-2)
4. Drain the hydraulic fluid from the machine by following the procedure described on page 4-8 of this manual.



5. Disconnect the oil cooler lines from the cooler as shown. It may be helpful to use a crow's foot to loosen the nuts on these tubes. (fig. 8-3)

**Note:** Cap and plug all hydraulic tubes/ports to keep dirt debris out of the hydraulic system.

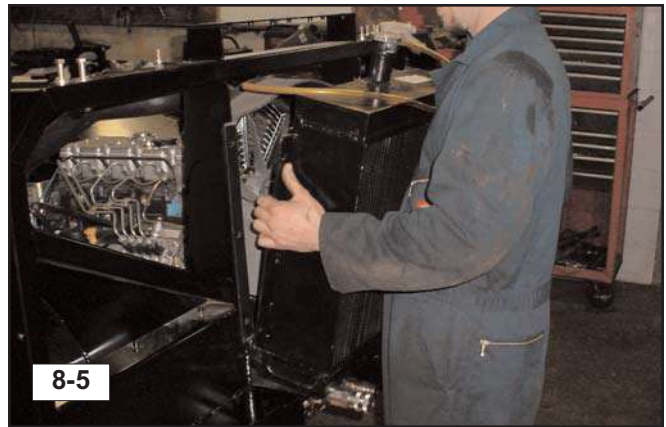
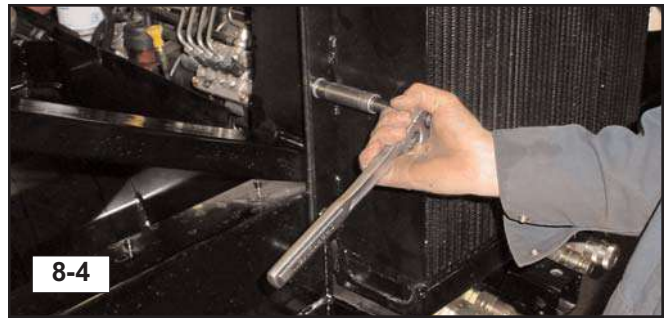

6. Remove the bolts securing the cooler to the chassis, then remove the cooler from the machine. (fig. 8-4, 8-5)

### Installation

1. To install the radiator/oil cooler, reverse the removal procedure.

## Fan, Fan Spacer & Shrouding Removal

### Required Tools

Socket/Combination Wrenches



1. Relieve the tension on the engine drive belt to allow the fan and spacer to be removed. Loosen the alternator pivot and adjustment bolts, then rotate the alternator toward the engine to put slack in the belt. (fig. 8-6)

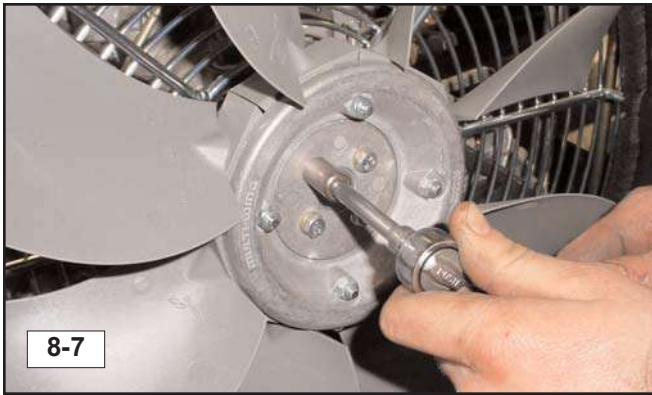

2. Remove the bolts securing the fan and spacer to the engine, then remove the fan and spacer from the machine. (fig. 8-7, 8-8)



3. Once the fan has been removed, the shroud and guard can simply be lifted out of the machine as shown. (fig. 8-9)

### Installation

1. To install the fan, spacer, and shrouding, reverse the removal procedure.



**Intentionally left blank**

# 9. Hydraulic Reservoir

## Chapter Overview

This chapter provides removal and installation procedures for the hydraulic reservoir.

## Personal Safety

### **!WARNING!**

Improper or incomplete maintenance/repair of a Rubber Track Utility Vehicle can be dangerous and may result in machine damage, injury or even death.

Do not attempt to perform repair or maintenance on a Rubber Track Utility Vehicle until you have read and fully understood the information in this manual.

Refer to the Operation and Maintenance manual for instructions regarding proper machine operation techniques before operating any Rubber Track Utility Vehicle.

## Machine Preparation

### **!WARNING!**

Accidental machine starting can cause injury or even death to personnel working on a Rubber Track Utility Vehicle.

As a precaution, disconnect the battery cables from the battery terminals, tape the battery clamps and remove the key from the ignition switch prior to performing any service work on a Rubber Track Utility Vehicle.

Place a "Do Not Operate" tag prominently on the machine to inform personnel that the machine is being worked on.

Prior to performing any type of service work on a Rubber Track Utility Vehicle, read and understand Chapter 1 (Product Safety) for personal safety information.

## Removal and Installation

Removal and installation procedures are provided for the following hydraulic components.

- Hydraulic Reservoir (tank)
- Suction Screen

**Note:** Procedures are provided for only those hydraulic components listed above. However, exploded parts diagrams exist in the SC-50 Parts manuals to serve as visual aids in the removal and installation of other system components.

**Note:** Refer to pages 3-1, 3-2 and 3-3 for additional hydraulic circuit and system information.

## Hydraulic Reservoir

### Removal

#### Required Tools

Screwdriver  
Combination/Socket Wrench

### **!WARNING!**

Remove any hydraulic attachment, relax all actuators and make sure the hydraulic oil is cool before removing any components or lines. Hot or pressurized oil can cause personal injury.

### **NOTICE**

Collect and contain liquids in suitable containers. Dispose of all liquids according to local regulations and mandates.

### **NOTICE**

During disassembly, plug and cap all hoses and fittings to prevent system fluid loss or contamination.

### 9. Hydraulic Reservoir

1. Drain the hydraulic fluid from the reservoir by following the procedure described on page 4-8 of this manual.
2. Remove the cargo bed from the machine according to the procedure on page 7-3 of this manual.



3. Disconnect all lines and hoses from the reservoir. (fig. 9-1)

**Note:** You may need to disconnect the large steel inlet tube from the charge/auxiliary pump in order to remove the system inlet hose from the reservoir. (fig. 9-1)



4. Disconnect the lead connected to the hydraulic oil temperature sending unit as shown. (fig. 9-2)



5. Remove the clamps securing the brake and two-speed lines to the chassis. (fig. 9-3)

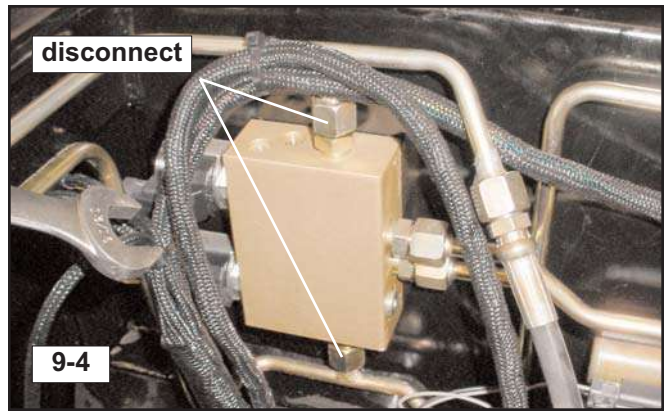

6. Disconnect the brake and two-speed tubes from the valve block at the top and bottom. (fig. 9-4)



7. Pivot the tubes over the reservoir and out of the way. (fig. 9-5)

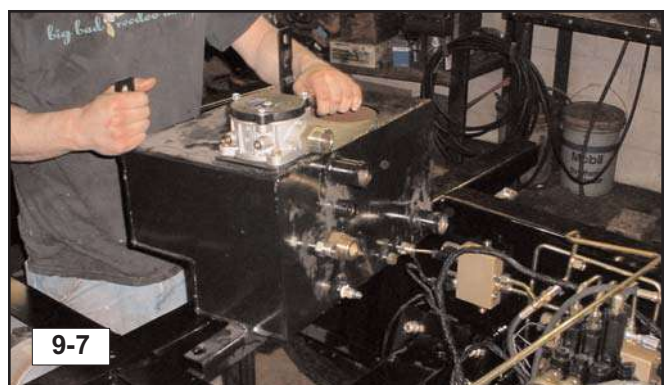

8. Remove the bolts securing the reservoir to the chassis, then remove the reservoir. (fig. 9-6, 9-7)

## Installation

1. To reinstall the hydraulic reservoir, reverse the removal procedure.

## Suction Screen

### Removal

<b>Required Tools</b>
-----------------------

<b>Combination/Socket Wrench</b>
----------------------------------

1. Remove the cargo bed as described in the procedure on page 7-3 of this manual.



2. Remove the cover from the hydraulic reservoir as shown. (fig. 9-8)

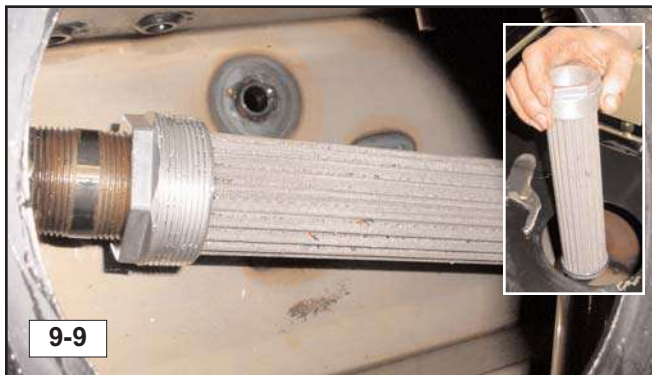

3. Thread the suction screen off of the system inlet tube and remove through the upper opening as shown. (fig. 9-9)

## Installation

1. To reinstall the suction screen, reverse the removal procedure.

**Intentionally left blank**

# 10. Hydraulic Components

## Chapter Overview

This chapter provides removal and installation procedures for various hydraulic components.

## Personal Safety

### **!WARNING!**

Improper or incomplete maintenance/repair of a Rubber Track Utility Vehicle can be dangerous and may result in machine damage, injury or even death.

Do not attempt to perform repair or maintenance on a Rubber Track Utility Vehicle until you have read and fully understood the information in this manual.

Refer to the Operation and Maintenance manual for instructions regarding proper machine operation techniques before operating any Rubber Track Utility Vehicle.

## Machine Preparation

### **!WARNING!**

Accidental machine starting can cause injury or even death to personnel working on a Rubber Track Utility Vehicle.

As a precaution, disconnect the battery cables from the battery terminals, tape the battery clamps and remove the key from the ignition switch prior to performing any service work on a Rubber Track Utility Vehicle.

Place a "Do Not Operate" tag prominently on the machine to inform personnel that the machine is being worked on.

Prior to performing any type of service work on a Rubber Track Utility Vehicle, read and understand Chapter 1 (Product Safety) for personal safety information.

### **NOTICE**

The hydraulic system fluid should be changed following any hydraulic component service according to the procedure described on page 4-8.

## Removal and Installation

Removal and installation procedures are provided for the following hydraulic components.

- Charge/Auxiliary Pump
- Tandem (Drive) Pump
- 2-speed/Brake Manifold
- Shuttle Block
- Pilot Generation Block
- Auxiliary Valve/Solenoid Block Assembly
- Steering Valve
- Directional Control Valve

**Note:** Procedures are provided for only those hydraulic components listed above. However, exploded parts diagrams exist in the SC-50 Parts manuals to serve as visual aids in the removal and installation of other system components.

**Note:** Refer to pages 3-1, 3-2 and 3-3 for additional pump and hydraulic circuit information.

## Charge/Auxiliary Pump Removal

### Required Tools

Combination Wrench
Socket Wrench

### **!WARNING!**

Disconnect any attachment, relax all actuators and make sure the hydraulic oil is cool before removing any components or lines. Hot or pressurized oil can cause personal injury.

### **NOTICE**

Collect and contain liquids in suitable containers. Dispose of all liquids according to local regulations and mandates.

### **NOTICE**

During disassembly, plug and cap all hoses and fittings to prevent system fluid loss or contamination.

Rubber Track Utility Vehicle  
**10. Hydraulic Components**

1. Relax any hydraulic actuators to relieve pressure within the hydraulic system.
2. Turn the ignition switch to the **OFF** position and remove the key to avoid accidental start.
3. Drain the hydraulic fluid. Refer to page 4-8 for the hydraulic fluid and filter change procedure.
4. Remove the cargo bed according to the procedure on page 7-3 of this manual.
5. Remove the belly pan beneath the center of the machine.



6. Disconnect the inlet tube from the charge/auxiliary pump as shown. (fig. 10-1)

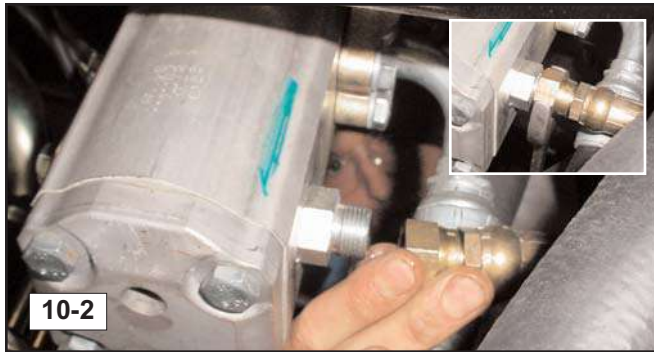

7. Disconnect the outlet hoses from the auxiliary and charge pumps as shown. (fig. 10-2, 10-3)

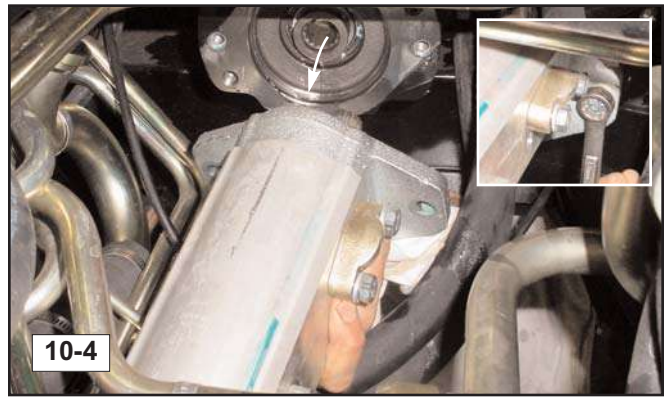

8. Remove the bolts securing the charge/auxiliary pump to the drive pump, then remove it through the bottom of the machine as shown. (fig. 10-4)

### Installation

1. To install the charge/auxiliary pump, reverse the removal procedure.

### Tandem (Drive) Pump Removal

#### Required Tools

Combination Wrench

Socket Wrench

Screwdriver (blade type)

1. Remove the engine cover and unfasten and move the heater (if equipped) from its brackets to access the drive pump.
2. Remove the charge/auxiliary pump as described on page 10-1 of this manual.



3. Label the hoses and pump housing as shown or with your own method to ensure that all hoses are connected to the proper ports during reinstallation. (fig. 10-5)

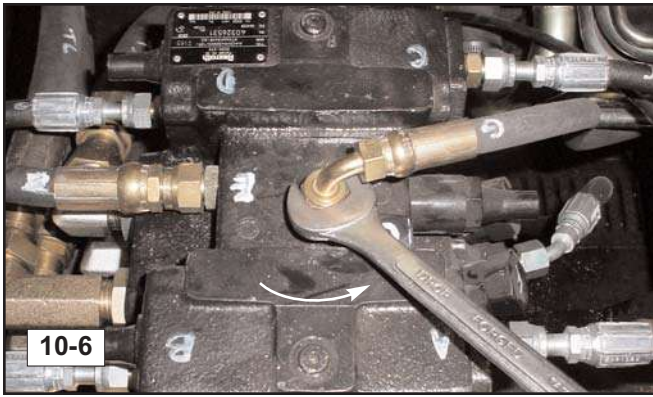

10-6



10-7

4. Loosen and disconnect all of the hoses from the drive pump fittings with the exception of the drive hoses. (fig. 10-6, 10-7)

**Note:** Make sure all hoses are labeled in some way to ensure correct connection during reinstallation.

**Note:** It is not necessary to remove most fittings from the pump. Disconnect the hoses where they attach to the various fittings to allow for pump removal.

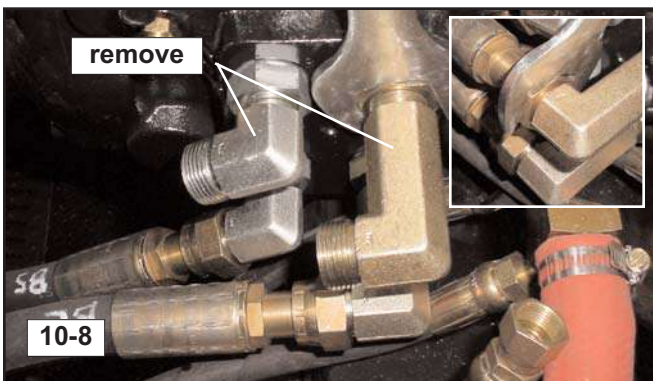

10-8

5. Disconnect the drive hoses from the fittings at the pump. (fig. 10-8)

**Note:** When disconnecting the drive hoses, you will most likely need to remove the upper 90° fittings in order to access the lower hoses to disconnect them.

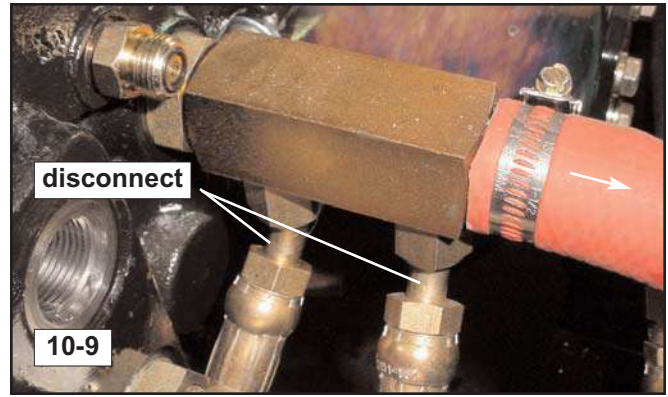

10-9

6. Disconnect the hoses from the brass pump return outlet fitting. (fig. 10-9)

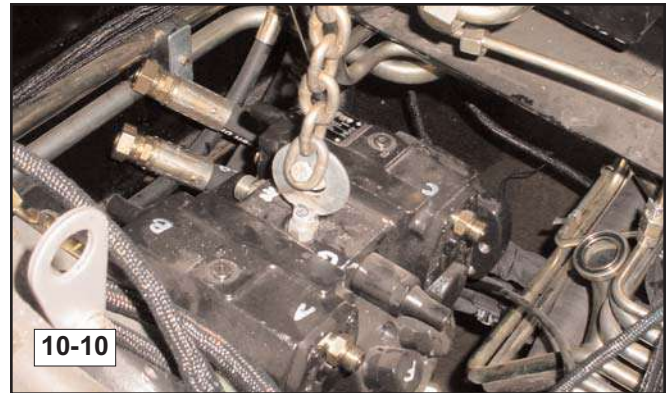

10-10

7. If possible, use an eyelet style bolt similar to the one pictured here to attach the pump to an engine hoist. If one is not available, thread two (or more) lifting straps under the pump (one at each end) and attach them to the hoist to support it while the mounting bolts are removed. (fig. 10-10)



10-11

8. Once the pump is properly supported, remove the bolts securing it to the engine adapter plate. (fig. 10-11)



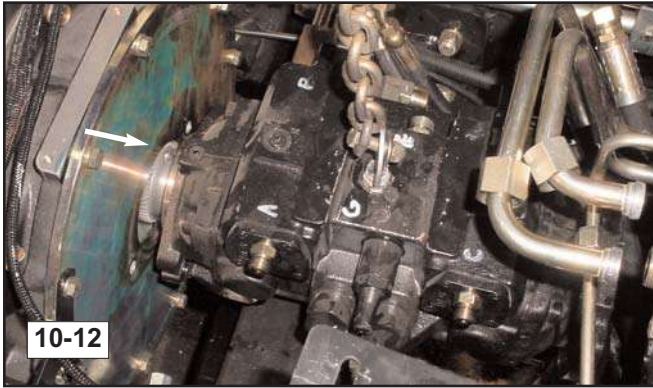

9. Once the bolts have been removed, slide the pump backwards out of the engine. (fig. 10-12)

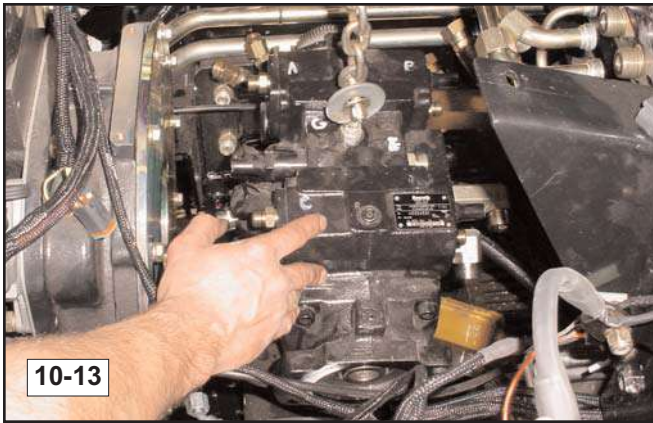

10. Rotate the pump until it is sideways inside the chassis as shown. to help it to clear the other components inside the engine compartment during removal. (fig. 10-13)

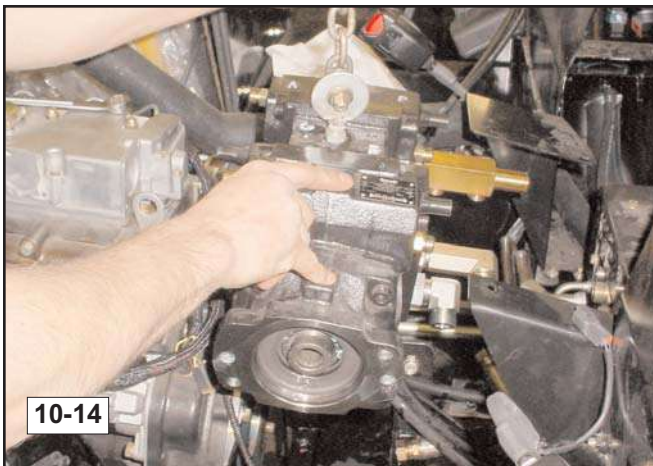

11. Lift the drive pump out of the engine compartment with the engine hoist as shown. (fig. 10-14)

## Installation

1. To install the drive pump, reverse the removal procedure.

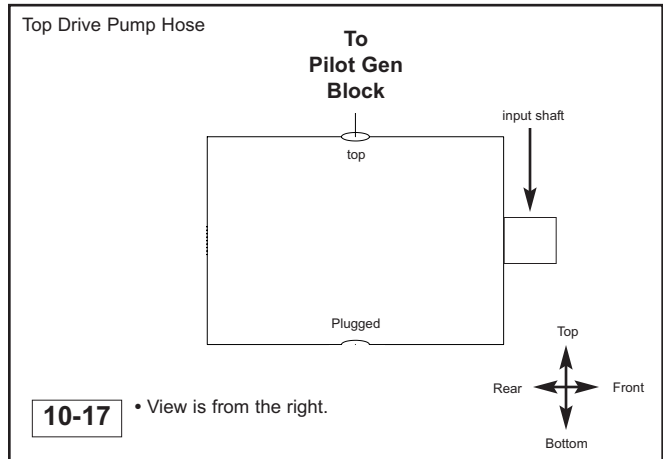
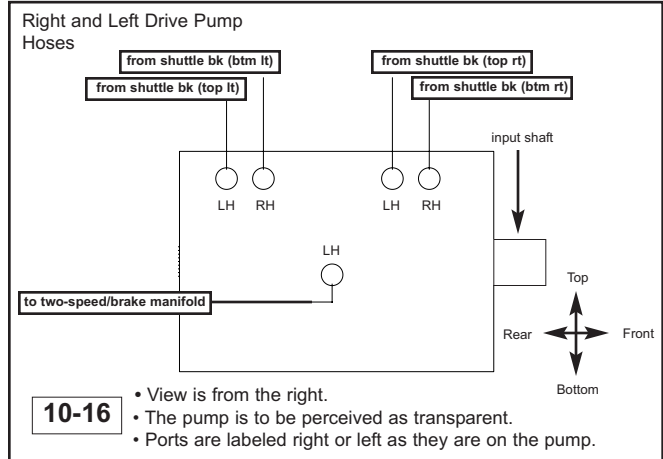
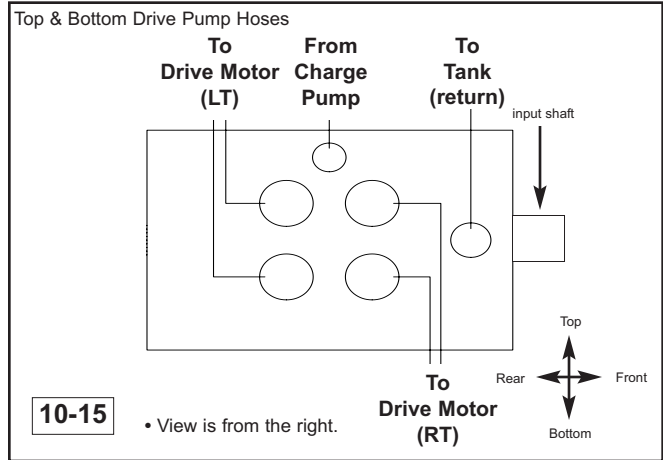

## Two-Speed/Brake manifold Removal

<b>Required Tools</b>
Combination Wrench
Socket Wrench

1. Relax any hydraulic actuators to relieve pressure within the hydraulic system.
2. Turn the ignition switch to the **OFF** position and remove the key to avoid accidental start.
3. Remove the cargo bed according to the procedure on page 7-3 of this manual.

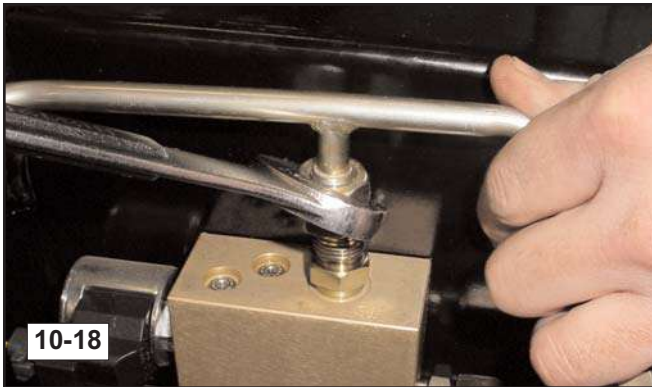

4. Disconnect the upper and lower tubes from the two speed brake manifold as shown. (fig. 10-18)

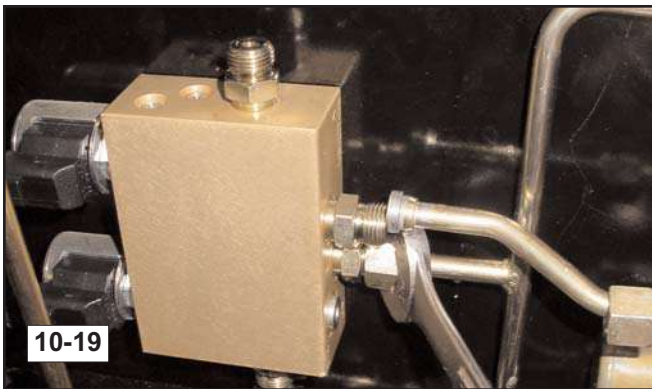

5. Disconnect the forward tubes from the two speed brake manifold as shown. (fig. 10-19)

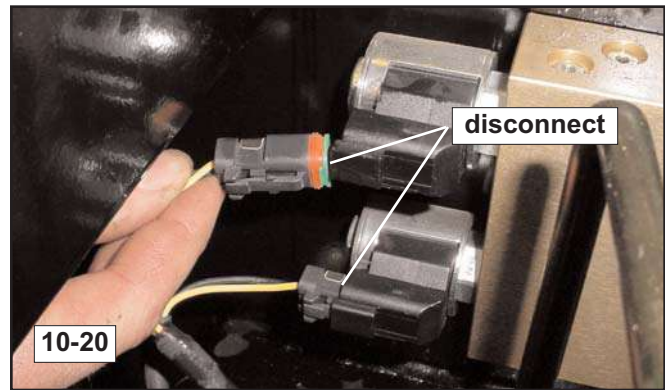

6. Disconnect the two connectors running to the solenoids from the main wiring harness. (fig. 10-20)

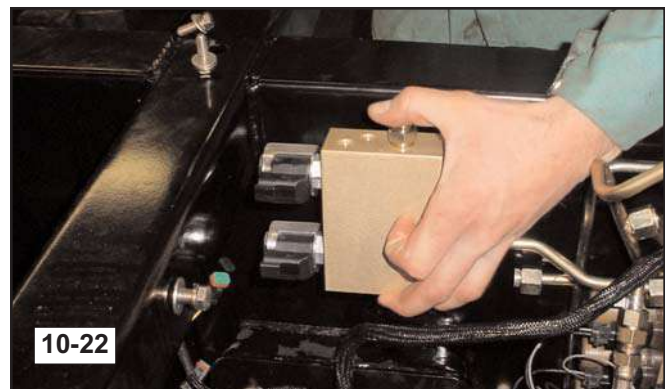
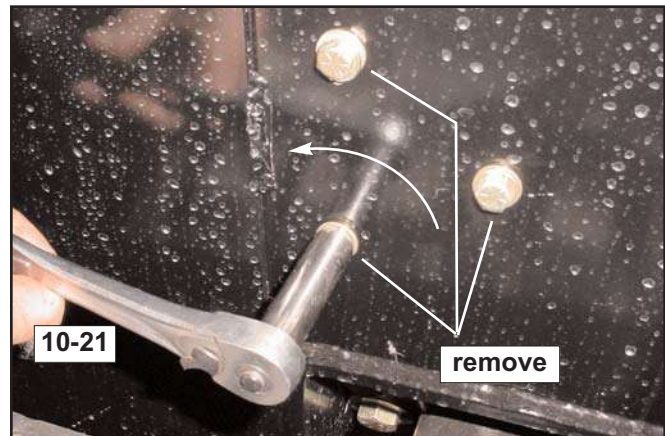

7. Remove the bolts securing the manifold to the chassis (from the outside) as shown, then lift and remove the manifold from the machine. (fig. 10-21 & 10-22)

**Note:** It may make it easier to remove the manifold if you remove the tube clamps securing the upper tube to the chassis along the frame crossmember, then pivot it up and out of the way for added clearance.

## Installation

1. To install the two-speed/brake manifold, reverse the removal procedure.

## Shuttle Block

### Removal

<b>Required Tools</b>
<b>Combination Wrench</b>
<b>Socket Wrench</b>

1. Relax any hydraulic actuators to relieve pressure within the hydraulic system.
2. Turn the ignition switch to the **OFF** position and remove the key to avoid accidental start.
3. Remove the belly pan beneath the engine.
4. Drain the hydraulic fluid from the machine as described on page 4-8 of this manual.



10-23

5. Label, then disconnect the hoses from the top and bottom of the shuttle block as shown. (fig. 10-23)

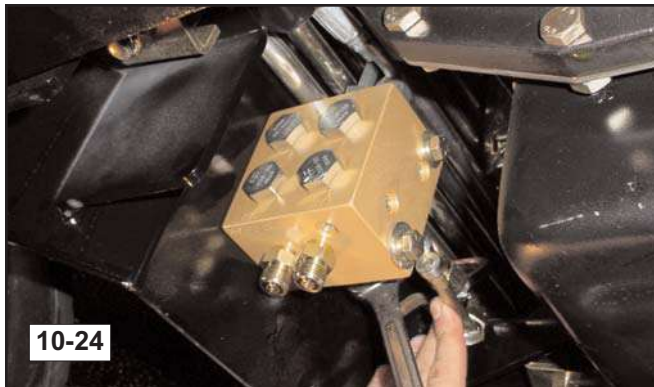

10-24

6. Disconnect the tubes from the front of the shuttle block. (fig. 10-24)

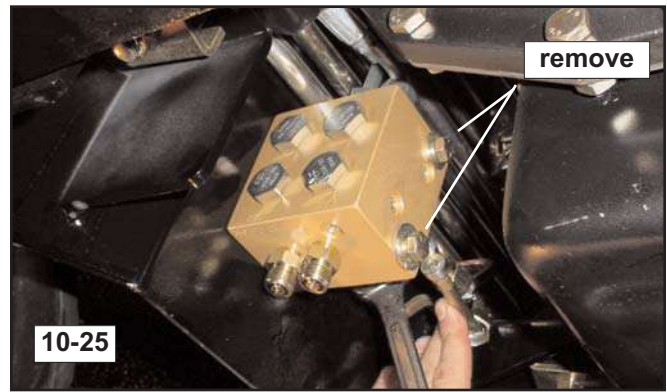

10-25

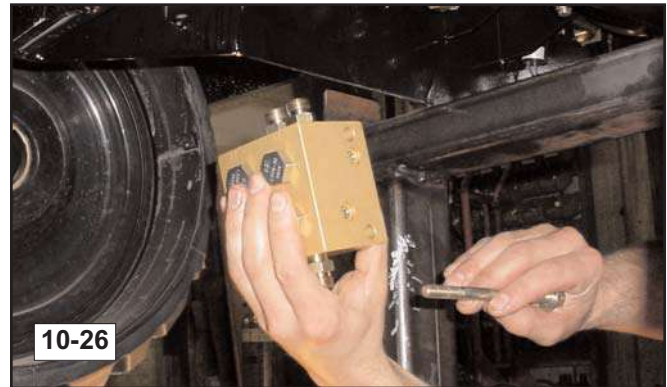

10-26

7. Remove the bolts securing the block to the chassis as shown. Support the block when removing the bolts to avoid dropping it. Remove it from the machine. (fig. 10-25, 10-26)

### Installation

1. To install the shuttle block, reverse the removal procedure.

## Pilot Generation Block Removal

<b>Required Tools</b>
<b>Combination/Socket Wrenches</b>
<b>Crows foot</b>

1. Relax any hydraulic actuators to relieve pressure within the hydraulic system.
2. Turn the ignition switch to the **OFF** position and remove the key to avoid accidental start.
3. Remove the belly pans beneath the engine and reservoir.
4. Drain the hydraulic fluid from the machine as described on page 4-8 of this manual.



5. Disconnect the tubes attached to the "T" fitting on the top of the pilot generation block. These nuts are difficult to reach and a crows foot attached to a ratchet may be helpful in disconnecting these tubes. (fig. 10-27)



6. Disconnect the hose from the lower 90° fitting as shown. (fig. 10-28)



7. Disconnect the tube from the forward fitting on the pilot generation block as shown. (fig. 10-29)



8. Remove the bolts securing the pilot generation block to the chassis. (fig. 10-30)



9. Once all hoses and tubes are disconnected, disconnect the wire harness from the solenoid and remove the block from the machine. (fig. 10-31)

## Installation

1. To install the pilot generation block, reverse the removal procedure.

## Auxiliary Valve/Solenoid Block Assembly Removal

<b>Required Tools</b>
-----------------------

<b>Combination/Socket Wrenches</b>
------------------------------------

1. Relax any hydraulic actuators to relieve pressure within the hydraulic system.
2. Turn the ignition switch to the **OFF** position and remove the key to avoid accidental start.
3. Remove the cargo bed according to the procedure on page 7-3 of this manual.
4. Drain the hydraulic fluid from the machine as described on page 4-8 of this manual.

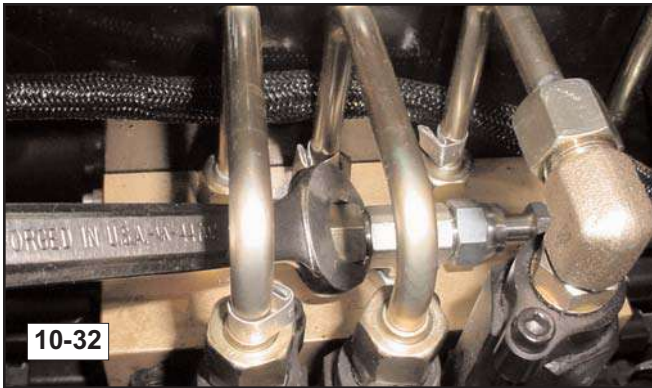

5. Disconnect the tubes from the t-fitting on the top of the solenoid block. (fig. 10-32)



6. Disconnect the tubes from the valve assembly as shown. (fig. 10-33)

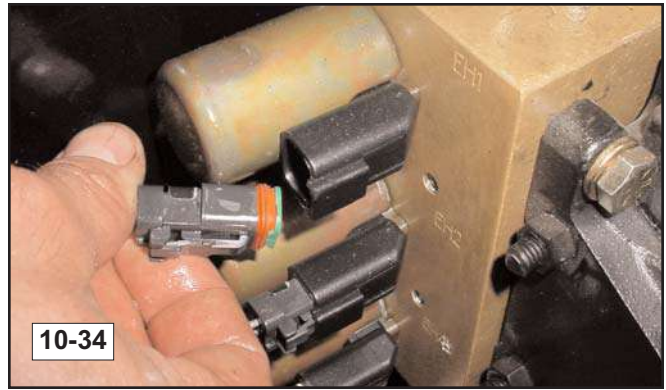

7. Disconnect the solenoids from the wire harness as shown. It may be wise to label the connectors to aid during installation. (fig. 10-34)



8. Remove the bolts securing the block/valve assembly to the chassis. Support the weight of the block/valve as you remove the bolts. (fig. 10-35)



9. Lift and remove the valve/block assembly from the machine. (fig. 10-36)

### Installation

1. To install the auxiliary valve/solenoid block assembly, reverse the removal procedure.

## Steering Valve & Plunger Removal

### Required Tools

Combination/Socket Wrenches  
Hydraulic Caps/Plugs  
Allen Wrenches (t-handle)

1. Relax any hydraulic actuators to relieve pressure within the hydraulic system.
2. Remove the dash panel as described on page 6-6 of this manual.



3. Remove the screws securing the valve to the steering mechanism weldment. (fig. 10-37)

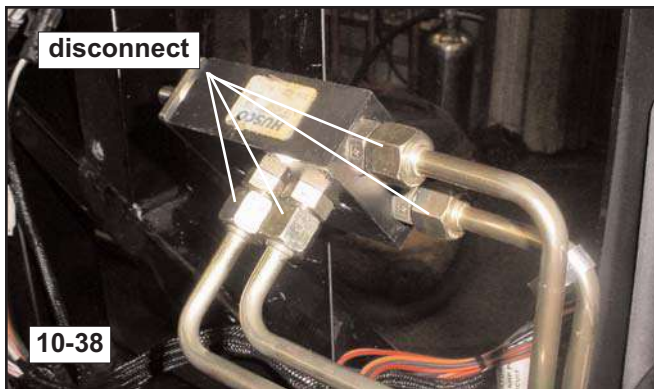

4. Disconnect the tubes from the valve, cap and plug the orifices to avoid fluid loss or contamination, then remove the valve from the machine.

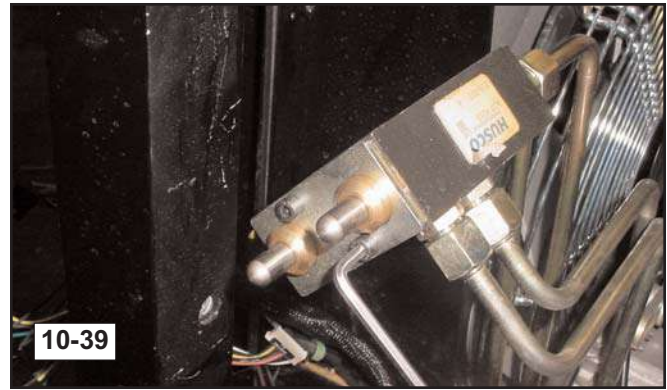

5. If the plungers need to be removed, it is best to first remove the valve as described in steps 1-4 of this procedure. Then, remove the two screws securing the plunger retaining plate. (fig. 10-39)

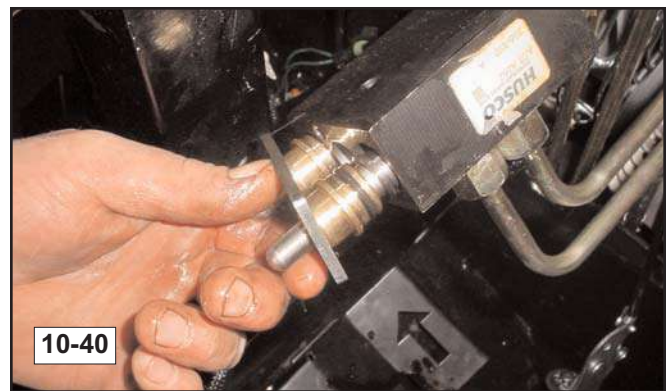

6. Gently remove the plate and the plungers should slide out with it. Make sure to do this carefully to avoid dropping parts. Note the order of part assembly upon removal to aid during reassembly. (fig. 10-40)

## Installation

1. To install the steering valve assembly, reverse the removal procedure.

## Directional Control Valve Removal

### Required Tools

Combination/Socket Wrenches  
Hydraulic Caps/Plugs  
Allen Wrenches (t-handle)

1. Relax any hydraulic actuators to relieve pressure within the hydraulic system.



2. Remove the bolts securing the foot pedal pivot pin in place. (fig. 10-41)



3. Slide the pin out of the assembly and remove the foot pedal from the machine. (fig. 10-42)

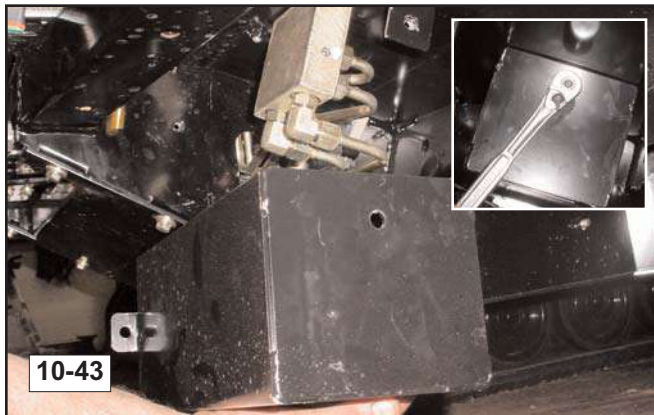

4. Remove the bolts securing the control valve cover to the chassis. (fig. 10-43)

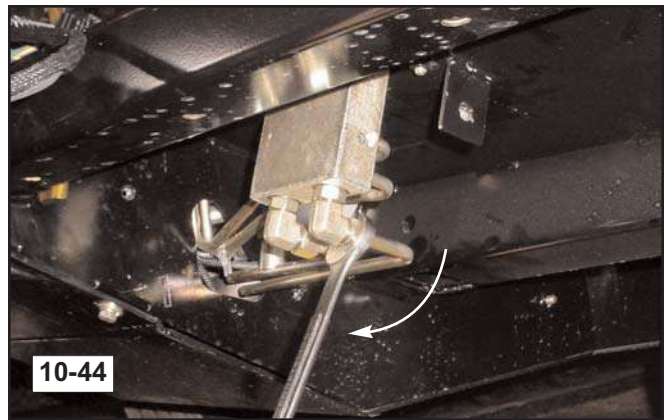

5. Disconnect the tubes from the control valve as shown. Cap and plug tubes and fittings to prevent fluid loss or contamination. (fig. 10-44)

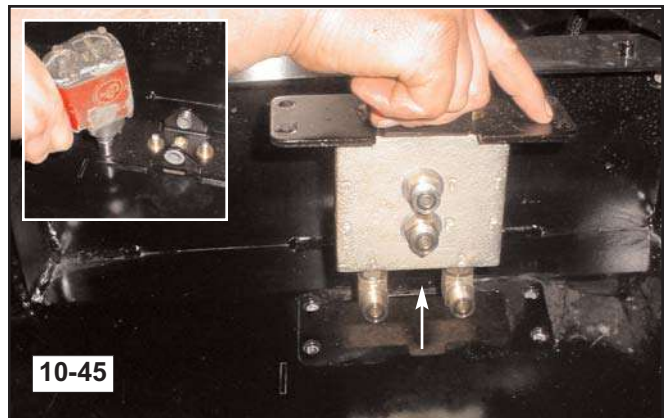

6. Remove the bolts securing the valve to the floor of the cab as shown, then lift the valve upward and remove. (fig. 10-45)

## Installation

1. To install the directional control valve, reverse the removal procedure.

# 11. Engine

## Chapter Overview

This chapter provides procedures for the removal and installation of the engine and associated components. If there is an issue that requires troubleshooting, refer to Chapter 15, Troubleshooting.

## Personal Safety

### !WARNING!

**Improper or incomplete maintenance/repair of a Rubber Track Utility Vehicle can be dangerous and may result in machine damage, injury or even death.**

**Do not attempt to perform repair or maintenance on a Rubber Track Utility Vehicle until you have read and fully understood the information in this manual.**

**Refer to the Operation and Maintenance manual for instructions regarding proper machine operation techniques before operating any Rubber Track Utility Vehicle.**

## Machine Preparation

### !WARNING!

**Accidental machine starting can cause injury or even death to personnel working on a Rubber Track Utility Vehicle.**

**As a precaution, disconnect the battery cables from the battery terminals, tape the battery clamps and remove the key from the ignition switch prior to performing any service work on a Rubber Track Utility Vehicle.**

**Place a “Do Not Operate” tag prominently on the machine to inform personnel that the machine is being worked on.**

Prior to performing any type of service work on a Rubber Track Utility Vehicle, read and understand Chapter 1 (Product Safety) for personal safety information.

## Removal and Installation

Removal and installation procedures are provided for the following engine related components.

- Battery
- Exhaust
- Air Cleaner Housing
- Engine

**Note:** Procedures are provided for only those engine associated components listed above. However, exploded parts diagrams exist in the SC-50 parts manuals to serve as visual aids in the assembly and disassembly of other system components.

## Battery Removal

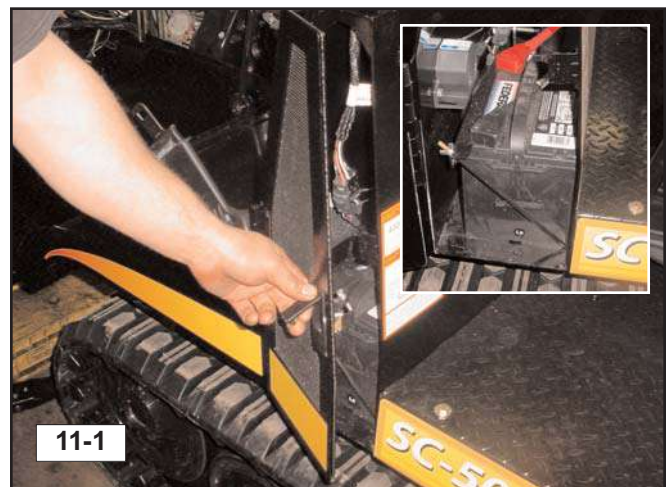

11-1

1. Open the access door to the rear console on the driver's side of the machine. (fig. 11-1)



11-2

2. Disconnect the battery terminals from the battery and lay them aside. (fig. 11-2)



## 11. Engine



3. Remove the wing nuts from the battery retaining tension rods as shown. (fig. 11-3)



4. Lift and remove the battery retaining bar and tension rods by pivoting them out of the console as shown. (fig. 11-4)



5. Slide the battery out of the console and remove. (fig. 11-5)

### Installation

1. To install the battery, reverse the removal procedure.

## Exhaust System

### Removal

#### Required Tools

Combination/Socket Wrench

Pliers (if jointed section must be disassembled)

Penetrating Lubricant

#### !WARNING!

The exhaust system is very hot at operating temperature. Make sure the machine is off and cool before attempting to service the exhaust system.

1. Remove the forward belly pan to access the exhaust system.

**Note:** Removal of the cargo bed (page 7-3) may make muffler removal easier, but it is not required.

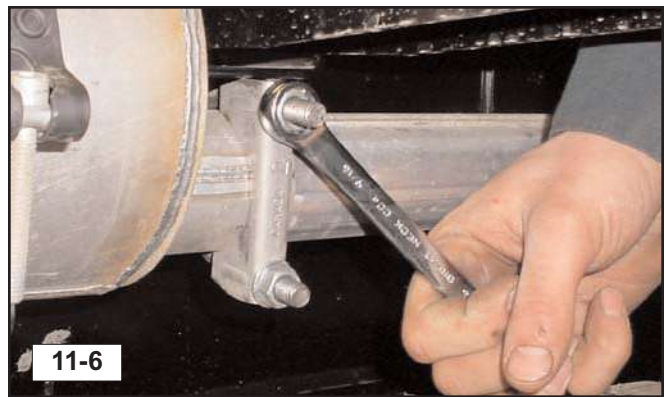

2. Remove the nuts on the exhaust clamp that secures the muffler to the exhaust pipe. (fig. 11-6)



3. Loosen the muffler clamp fasteners until they release, then slide the muffler rearward, and then away from the chassis to remove it. (fig. 11-7)



4. Remove the bolts securing the tailpipe to the chassis opening as shown. (fig. 11-8)

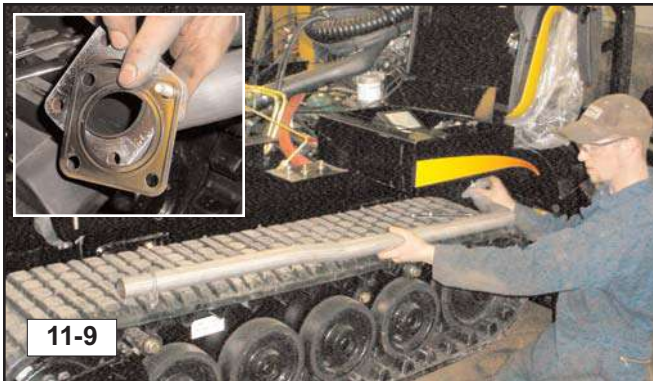

5. You may now remove the exhaust tail pipe from the machine. (fig. 11-9)

**Note:** The exhaust gasket(s) should be replaced whenever this joint is disassembled. (fig. 11-9)

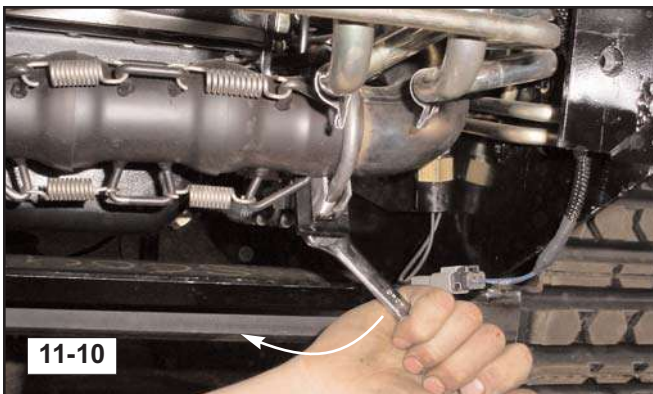

6. Loosen and remove the exhaust clamp securing the flex-joint section of pipe to the header down-tube. (fig. 11-10)

**Note:** Thoroughly coat all clamped exhaust pipe joints (make sure they are cool) with a penetrating lubricant prior to attempting to separate the pipe sections from each other. This will make removal significantly easier.

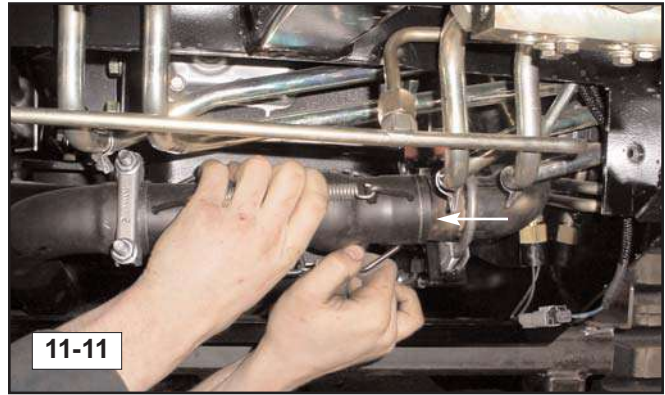

7. Slide the jointed section of pipe off the header down tube and remove. (fig. 11-11)

**Note:** Use caution not to damage the pipe or connection point during removal.



8. Remove the pipe section from the machine as shown. (fig. 11-12)

**Note:** If the individual sections of the jointed pipe need to be separated, use a pliers to remove the springs that hold them together, then separate them as required.

### Installation

1. To install the exhaust system, reverse the removal procedure.

## Air Cleaner Housing

### Removal

Required Tools
----------------

Combination/Socket Wrench
---------------------------

1. Remove the engine cover and open the passenger side access door on the rear console to access the air cleaner.



2. Remove the bolts securing the air cleaner clamp to the mounting plate. (fig. 11-13)

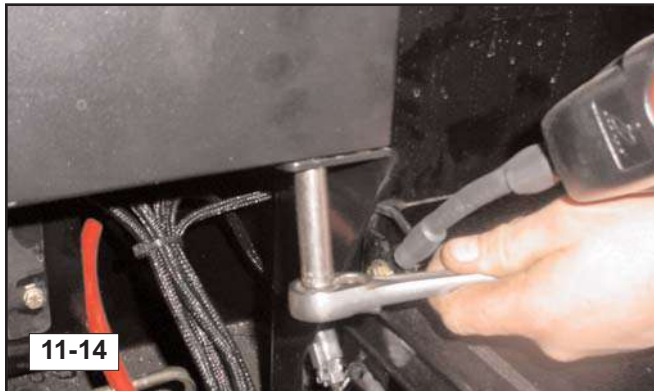

3. If your machine is equipped with a heater, remove the nuts (4) securing it to the mounting brackets as shown. (fig. 11-14)



4. Pivot the heater forward away from the opening in the rear console and lay it aside. (fig. 11-15)

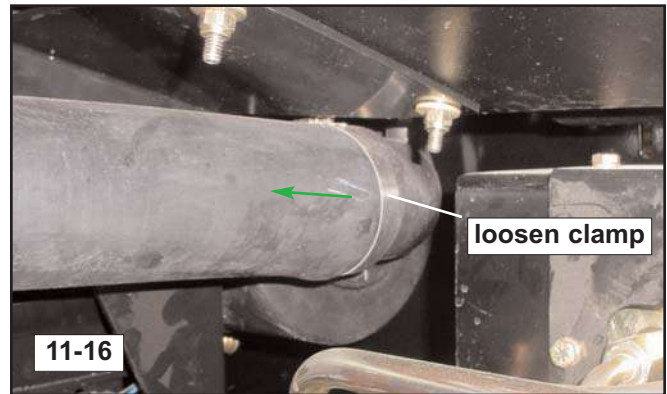

5. Loosen the hose clamp securing the intake hose to the air cleaner housing. Then slide the hose off of the housing and lay it aside. (fig. 11-16)



6. Remove the air cleaner housing from the center of the machine through the opening in the rear console. ( fig. 11-17)

### Installation

1. To install the air cleaner, reverse the removal procedure.

## Engine

### Removal

#### Required Tools

Combination/Socket Wrenches  
Engine Hoist & Straps/Chains

#### !WARNING!

The engine is very hot at operating temperature. Make sure the machine is off and cool before attempting to service the engine or any related components.

1. Remove the R.O.P.S., the engine cover, the front fascia, the dash panel, the oil cooler, the fan and shroud, the heater (if equipped), the exhaust, and the belly pan from beneath the engine.

**Note:** Please reference the appropriate sections of this manual to accomplish all aspects of step 1.



2. Use straps or chains to support the weight of the tandem drive and charge/auxiliary pumps in the chassis, then remove the bolts securing the drive pump from the engine adapter plate. (fig. 11-18)

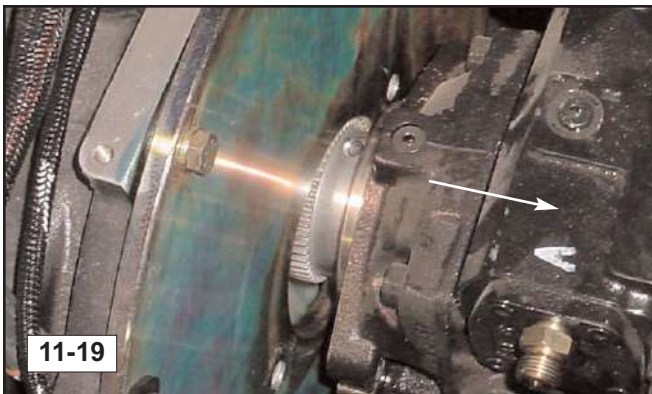

3. Once the bolts have been removed, slide the pump rearward and secure it away from the engine. (fig. 11-19)

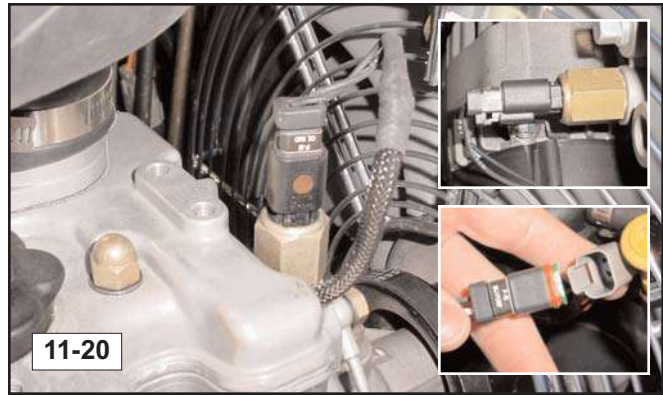

4. Disconnect the various sending units from the wiring harness. (fig. 11-20)

**Note:** Make note of the location and identity of each sending unit when you disconnect them to ensure proper connections when they are reconnected.

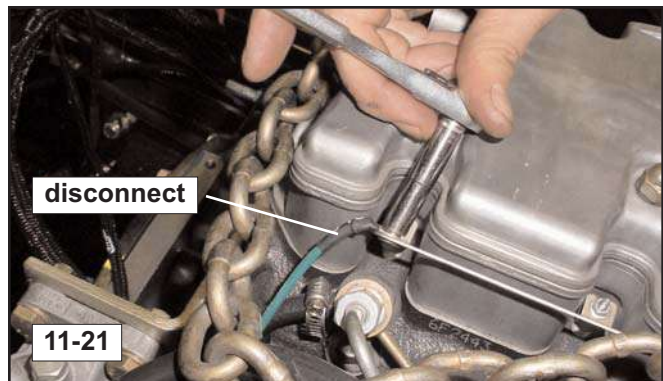

5. Disconnect the lead that runs to the glow plugs as shown. (fig. 11-21)

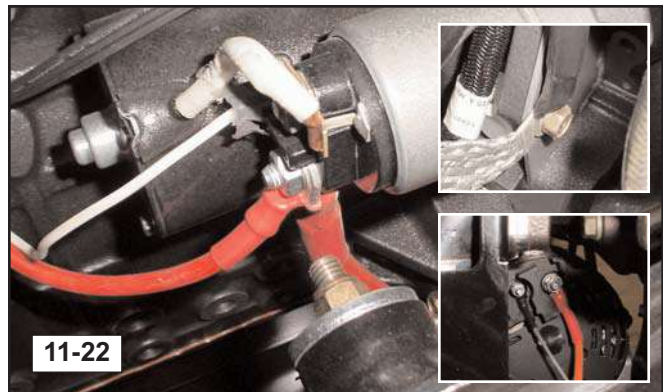

6. Disconnect the positive and negative battery leads from the engine as well as the leads connected to the alternator as shown. (fig. 11-22)

11. Engine



11-23

7. Once all connectors have been disconnected, remove the various p-clamps that secure the harness to the engine, then lay the harness aside. (fig. 11-23)

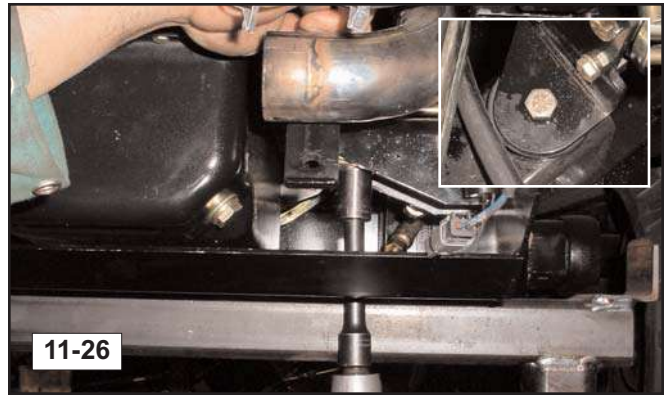

11-26

10. Remove the bolts (4) securing the engine mounts to the chassis. (fig. 11-26)

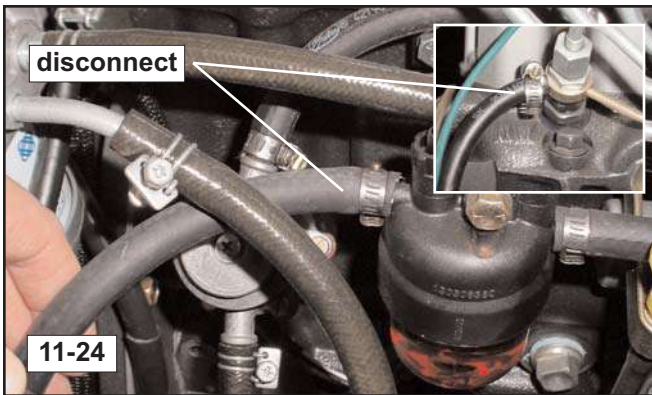

disconnect

11-24

8. Disconnect the fuel lines from the engine, then plug them and lay them aside. (fig. 11-24)

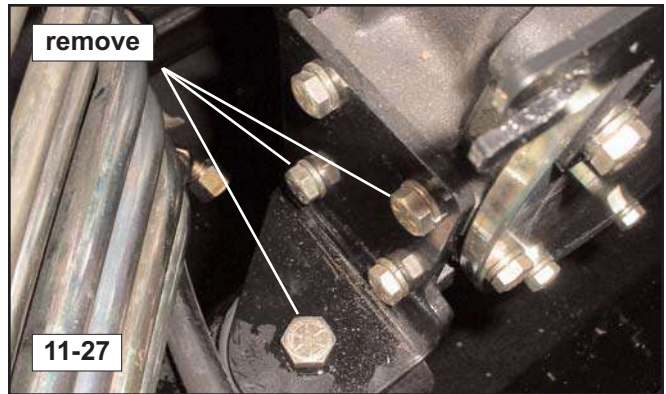

remove

11-27

11. Remove the bolts securing the rear engine mounts to the engine block, then remove the rear engine mounts from the engine to allow for removal. **See note below.** (fig. 11-27)

**Note:** Prior to performing step 11, raise the engine slightly to remove any pressure on the mounts.

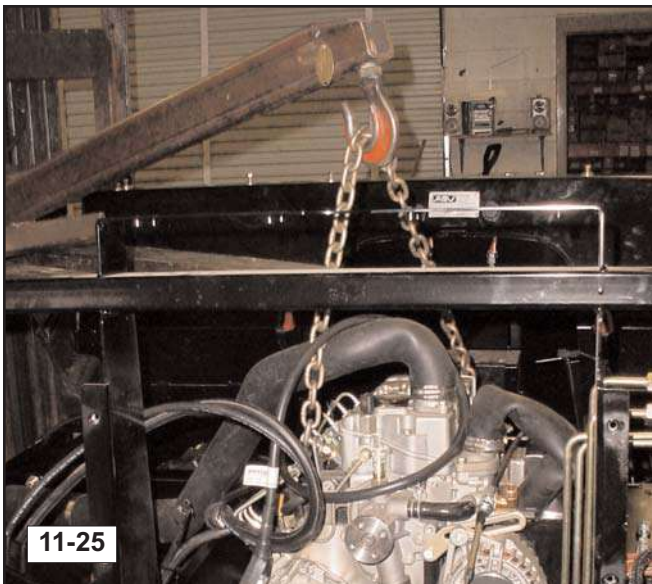

11-25

9. Attach an engine hoist to the lift points on the engine with chains that are capable of lifting the engine as shown and take the slack out of the chains prior to removing the engine mount bolts. (fig. 11-25)



11-28

12. Lift and remove the engine from the machine. (fig. 11-28)

## **Installation**

1. To install the engine, reverse the removal procedure.

### **!WARNING!**

Once the engine has been installed, make sure to properly reconnect and install all items removed during engine removal to ensure proper operation.

Prior to starting, make sure all fluids are at appropriate levels and that they have not been contaminated with dirt or debris during service. Change fluids or adjust fluid levels as needed to ensure proper operation.

---

**Intentionally left blank**

# 12. Undercarriage

## Chapter Overview

This chapter provides removal and installation procedures for the undercarriages.

**Note:** For track removal and installation procedures, refer to pages 4-9 through 4-13 of this manual.

**Note:** For drive sprocket roller inspection and replacement, refer to page 4-14 of this manual.

## Personal Safety

### **!WARNING!**

Improper or incomplete maintenance/repair of a Rubber Track Utility Vehicle can be dangerous and may result in machine damage, injury or even death.

Do not attempt to perform repair or maintenance on a Rubber Track Utility Vehicle until you have read and fully understood the information in this manual.

Refer to the Operation and Maintenance manual for instructions regarding proper machine operation techniques before operating any Rubber Track Utility Vehicle.

## Machine Preparation

### **!WARNING!**

Accidental machine starting can cause injury or even death to personnel working on a Rubber Track Utility Vehicle.

As a precaution, disconnect the battery cables from the battery terminals, tape the battery clamps and remove the key from the ignition switch prior to performing any service work on a Rubber Track Utility Vehicle.

Place a "Do Not Operate" tag prominently on the machine to inform personnel that the machine is being worked on.

Prior to performing any type of service work on a Rubber Track Utility Vehicle, read and understand Chapter 1 (Product Safety) for personal safety information.

## Removal and Installation

Removal and installation procedures are provided for the following undercarriage components.

- Idler Wheels
- Drive Sprocket
- Drive Motor
- Grease Tensioner

**Note:** Procedures are provided for only those components listed above. However, exploded parts diagrams exist in the SC-50 parts manuals to serve as visual aids in the removal and installation of other system components.

## Idler Wheels (10")

**Note:** The 10" idler wheels may be removed from the undercarriages without removing the tracks.

### Removal

#### Required Tools

- Socket/impact wrench & sockets
- Heavy duty hydraulic jack
- Combination wrenches
- Snap ring pliers
- ASV approved jack stands (2)

1. Raise the machine off of the ground and mechanically support it on ASV jack stands at a height that allows just enough clearance for track removal. The recommended distance is 3-4" from the bottom of the track to the ground.

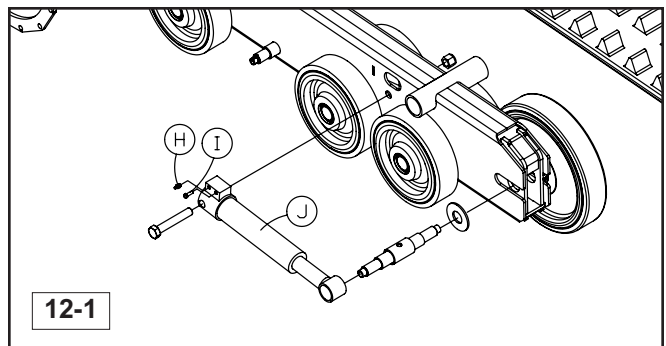

2. Loosen the bleeder bolt (I) on the grease tensioner unit (J) and allow grease to flow out until the front wheels are almost touching the 10" wheels behind them (fig. 12-1). Then tighten the bleeder bolt to hold them in place (fig. 12-2). This will put slack in the track and allow the outer 10" wheels to be removed (fig. 12-2).



12. Undercarriage

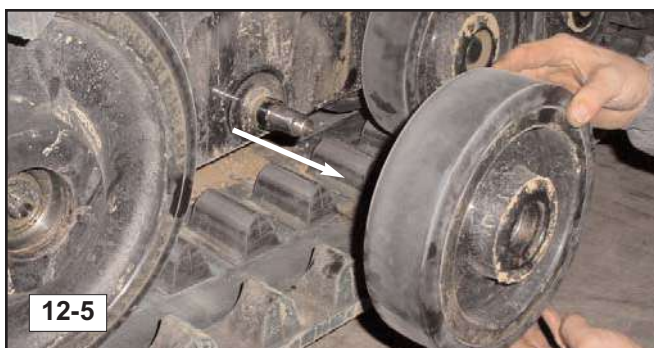
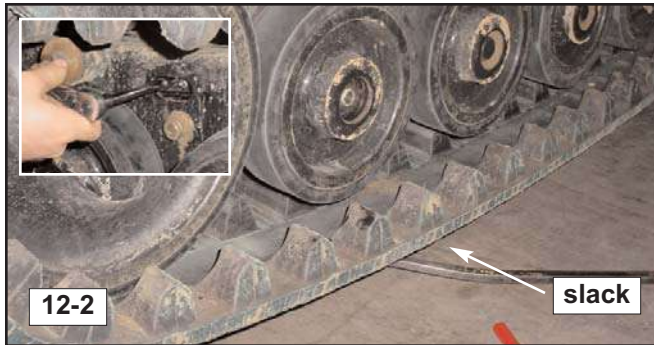

3. At this point, you may remove the outer 10" diameter wheels by first removing the outer snap rings and grease covers, then remove the nuts securing the wheel assemblies to the axle (fig. 12-3, 12-4). Then remove the wheels (fig. 12-5).

**Note:** A pry bar may be useful in helping to free the wheels from the axles for removal.

**Note:** If the inner wheels need to be removed, you must remove the bolts securing the undercarriages to the torsion axles, then slide the undercarriages out away from the chassis slightly to provide clearance for the wheels to be removed from their axles. (see steps 4-6 of this procedure)

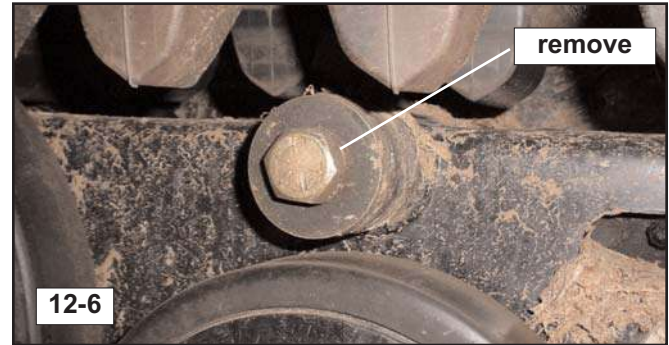

4. Remove the bolts securing the undercarriage to the torsion axles as shown. (fig. 12-6)
5. Use a port-a-power or similar device to gently slide the undercarriage away from the chassis on the axles. Slide the undercarriage outward only as far as needed to remove the inner wheels to prevent bending or damaging the drive hose tubes.
6. Perform step 3 of this procedure on the inner 10" wheels to remove them from the undercarriage.

**Installation**

1. To install the 10" idler wheels, reverse the removal procedure. **Torque the wheel mounting bolts upon installation to 111 +/- 10 Lb. Ft.**

## 14" Wheels

**Note:** The tracks must be removed in order to remove the 14" wheels from the undercarriage on the scout.

### Removal

#### Required Tools

Socket/impact wrench & sockets  
Heavy duty hydraulic jack  
Combination wrench  
Snap ring pliers  
ASV approved jack stands (2)

1. Perform the track removal procedure on pages 4-10 and 4-11 of this manual to remove the outer 14" front idler wheel and the track.



2. Remove the bolts securing the undercarriage to the torsion axles. (fig. 12-7)
3. Use a port-a-power or similar device to gently slide the undercarriage away from the chassis on the axles. Slide the undercarriage outward only as far as needed to remove the inner wheel to prevent it from falling off of the axles.



4. Remove the outer snap ring and grease cover on the inner front 14" idler wheel (fig. 12-8).



5. Remove the nut and washer from the axle, then remove the wheel from the axle. (fig. 12-9)

### Installation

1. To install the 14" idler wheels, reverse the removal procedure. **Torque the wheel mounting bolts upon installation to 111 +/- 10 Lb. Ft.**

### Drive Sprocket Removal

#### Required Tools

Socket/impact wrench & sockets  
3-jaw puller  
Snap ring pliers  
Hammer  
Large blade type screwdriver

1. Perform the track removal procedure on pages 4-10 and 4-11 of this manual to remove the track from the undercarriage.

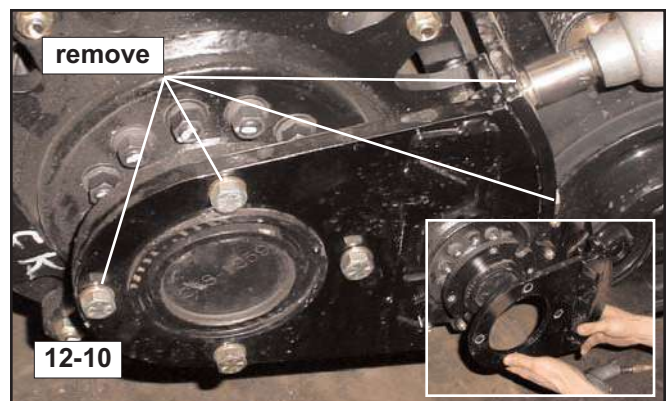

2. Remove the bolts securing the outboard bearing support plate to the bearing assembly and the rail weldment, then remove the support plate. (fig. 12-10)

## 12. Undercarriage



3. Remove the cap from the outboard bearing assembly as shown. The cap will be destroyed upon removal and must be replaced. (fig. 12-11)

**Note:** Use a large blade type screwdriver as shown. Drive it in at the outer edge of the cap, then pry the cap out. This is the quickest and most effective method and will prevent damage to the outboard bearing.



4. Remove the snap ring that holds the bearing assembly into the sprocket shaft. (fig. 12-12)



5. Use a puller to break the bearing assembly loose from the sprocket shaft. (fig. 12-13)



6. Once loose, remove the bearing assembly from the sprocket shaft as shown. (fig. 12-14)

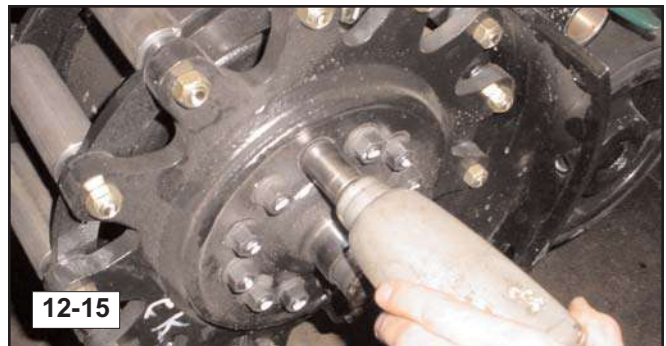

7. Remove the bolts securing the sprocket to the drive motor. (fig. 12-15)



8. Remove the sprocket from the undercarriage. (fig. 12-16)

**Note:** The sprocket is quite heavy, it may be a good idea to use a hoist and suitable lifting straps to remove it from the machine.

### Installation

1. To install the drive sprocket, reverse the removal procedure. **Torque the sprocket mounting bolts upon installation to 129 +/- 10 Lb. Ft.**

## Drive Motor Removal

### Required Tools

Socket/impact wrench & sockets  
Combination wrenches  
Hydraulic caps and plugs

1. Perform the track removal procedure on pages 4-10 and 4-11 of this manual to remove the track from the undercarriage.
2. Perform the drive sprocket removal procedure on page 12-3 of this manual.



3. Remove the clamp securing the drive motor hydraulic tubes to the undercarriage rail. (fig. 12-17)
4. Drain the hydraulic fluid according to the procedure on page 4-8 of this manual.

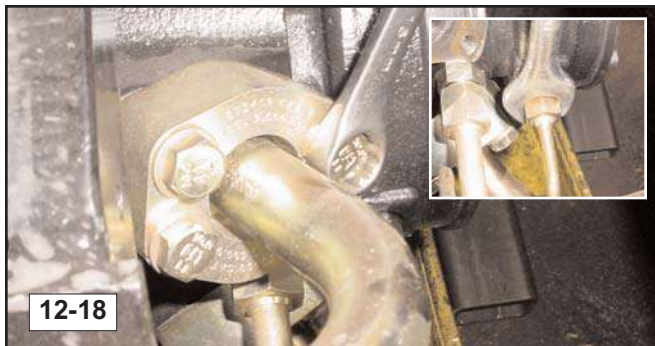

5. Disconnect the hydraulic tubes from the drive motor (noting their locations) as shown to allow for removal. Cap and plug all openings to keep dirt and debris out of the hydraulic system. (fig. 12-18, 12-19) (see note)



**Note:** You must remove the lower tube guard from the rail in order to access and disconnect the lower large hydraulic tube from the motor. (fig. 19).



6. Remove the bolts securing the drive motor to the rail. (fig. 12-20)



7. Remove the motor from the rail. (fig. 12-21)

**Note:** The drive motor is quite heavy, use a hoist and suitable lifting straps to remove it from the machine.

## Installation

1. To install the drive motor, reverse the removal procedure. **Torque the sprocket mounting bolts upon installation to 177 +/- 10 Lb. Ft.**

## Grease Tensioner Removal

### Required Tools

Socket/impact wrench & sockets

Combination wrenches

Plastic/rubber hammer

1. Perform the track removal procedure on pages 4-10 and 4-11 of this manual to remove the track from the undercarriage.



2. Remove the bolt securing the rear of the grease tensioner to the rail as shown. (fig. 12-22)



3. Use a plastic or rubber hammer to drive the assembly out of the rail through the front as shown. (fig. 12-23)

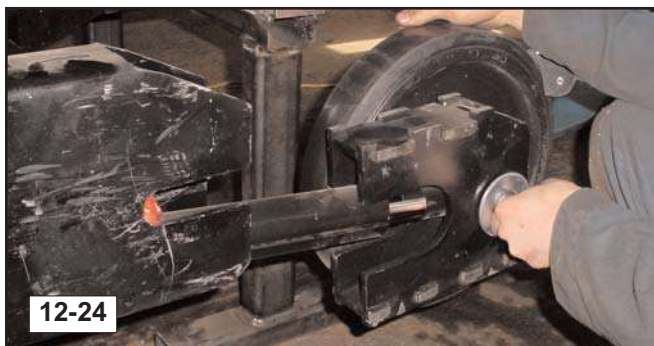

4. Once the tensioner assembly is free, remove it from the machine out the front of the rail as shown. (fig. 12-24)



5. Remove the wheel and axle from the assembly as shown. (fig. 12-25)



6. Remove the grease tensioner from the assembly as shown. (fig. 12-26)

## Installation

1. To install the grease tensioner, reverse the removal procedure.

## NOTICE

Disassembly of hydraulic components should only be performed by factory trained personnel experienced in the disassembly and repair of hydraulic components. Components should not be serviced during the warranty period without written instruction from the ASV service department. Component disassembly during this period may void the manufacturer's warranty.

## Chapter Overview

This chapter provides information on inspection, disassembly and assembly of major hydraulic components.

## Personal Safety

### !WARNING!

**Improper or incomplete maintenance/repair of a Rubber Track Utility Vehicle can be dangerous and may result in machine damage, injury or even death.**

**Do not attempt to perform repair or maintenance on a Rubber Track Utility Vehicle until you have read and fully understood the information in this manual.**

**Refer to the Operation and Maintenance manual for instructions regarding proper machine operation techniques before operating any Rubber Track Utility Vehicle.**

Prior to performing service work on a Rubber Track Utility Vehicle, read and understand Chapter 1 (Product Safety) for personal safety information.

### !WARNING!

When servicing any hydraulic component, make sure the machine is off and cool and that all of the hydraulic actuators are relaxed prior to disconnecting or removing any component from the system.

## NOTICE

When servicing any hydraulic component, keep in mind that any scratches or damage that can be felt with a fingernail on surfaces that parts move, slide, roll or rotate upon indicate a need for part replacement.

Hydraulic components must be kept extremely clean to ensure proper function and service life. Do not assemble any components that have not been inspected for damage and thoroughly cleaned prior to assembly.

**The hydraulic system fluid should be changed following any hydraulic component service according to the procedure described on page 4-8.**

# 13. Hydraulic Component Service Procedures

## Disassembly & Assembly

Disassembly and assembly procedures are provided for the following components:

- Hydraulic Cylinders
- Auxiliary Control Valve
- Drive motor
- Drive Pump
- Auxiliary Pump

**Note:** Procedures are provided for only those components listed above. However, exploded parts diagrams exist in the SC-50 parts manuals to serve as visual aids in the assembly and disassembly of other system components.

## Hydraulic Cylinder

### Disassembly

#### Required Tools

**Bench Vise**  
**Pipe Wrench**  
**Socket or Impact Wrench**  
**Screwdriver (blade type)**  
**Rubber or Dead Blow Hammer**  
**Small Pry Bar**

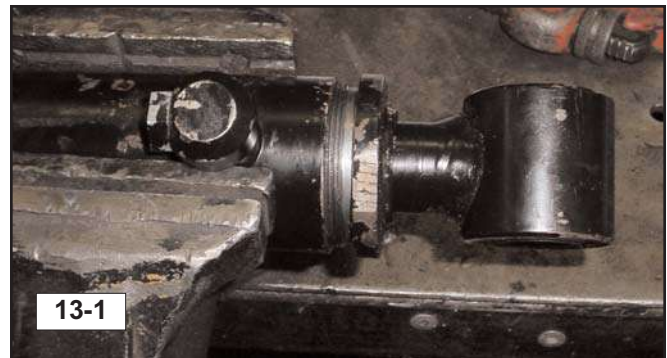

1. With machine off and cool and with hydraulic actuators relaxed, disconnect and cap hoses from the cylinder(s) to be serviced.

**Note:** When servicing cylinders, the attached components must be supported in a manner that allows the cylinders to be safely removed and installed. (dump box, blade, etc.)

2. Remove the cylinder(s) and secure it in a bench vise to aid in disassembly. (figure 13-1)
3. Place a suitable catch container beneath the rod end of the cylinder to catch any hydraulic oil that may leak out upon disassembly.



4. Use an open end or pipe wrench to turn and remove the end gland. (figure 13-2)

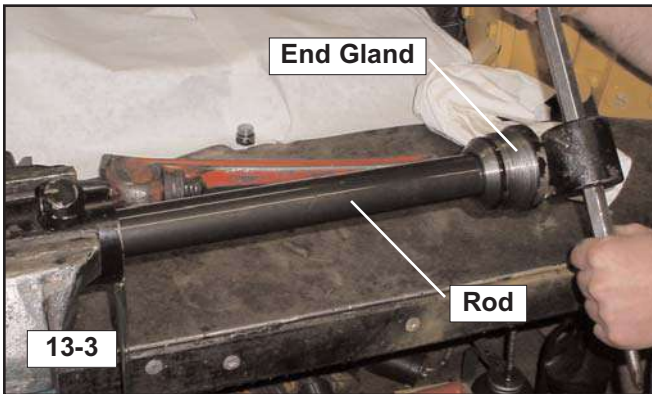

5. Use a pry bar or similar device to pull the rod and piston from the cylinder. (figure 13-3)

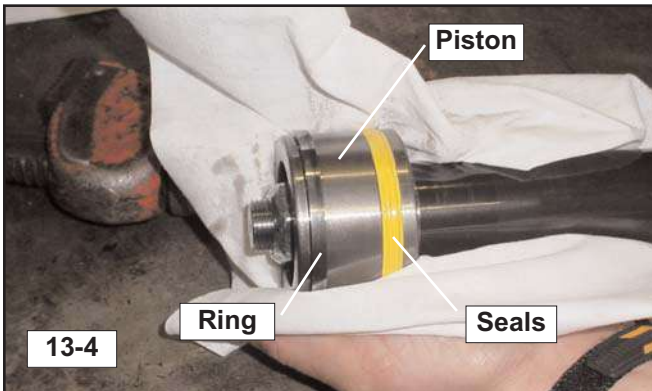

6. Inspect the piston surface, seals and ring for wear or damage. If any component appears to be damaged in any way, replace it. When inspecting the piston surface, look for scratches. If any are present that are deep enough to catch with your fingernail, the piston should be replaced. (figure 13-4)

**Note:** Seal imperfections or scratches on the piston, bore or rod will cause internal/external leakage and impaired function. Defective components must be repaired or replaced.



7. With the piston and rod removed from the cylinder, inspect the cylinder bore for scratches or other damage. If any are present that are deep enough to catch with your fingernail, the cylinder tube weldment should be replaced. (figure 13-5)



8. Remove the nut from the rod end. (figure 13-6)



9. Support the piston loosely from the underside (figure 13-7), thread the nut partially on to protect the threads and tap the rod end with a rubber or dead blow hammer to free the piston from the rod.

10. Once loose, remove the nut and piston from the rod.



11. Remove the seals and piston ring taking care not to scratch the piston. Also, pay close attention to seal and ring orientation and position to aid when installing new parts. (figures 13-8, 13-9)

13. Remove the tandem seals from the end gland paying close attention to the order of removal to aid during installation of the new seals. (fig. 13-11)



14. Remove the inner seal from the end gland. Pay attention to the seal orientation upon removal to aid during installation of the new seal. (fig. 13-12)



12. Gently tap the end gland off of the cylinder rod. (figure 13-10)

15. Remove the end gland outer seal from the end gland. (figure 13-10)

16. Thoroughly clean all parts to prevent contamination of hydraulic oil when reinstalled.

### Assembly

1. Install new seals and components in place of the originals paying close attention to orientation and location to ensure proper operation.
2. Lubricate the piston, ring, and seals with fresh hydraulic oil prior to assembly to avoid damage.
3. Reassemble components by reversing the disassembly process.

**Note:** During reassembly, use an impact wrench to tighten the piston retaining lock nut. Make sure the nut is tight and that there is no independent movement between the piston and rod before reassembling.



## Auxiliary Control Valve

### Disassembly

#### Required Tools

Socket Wrench  
Combination Wrench  
Screwdriver (blade type)  
Low Profile Needle Nose Pliers

1. With machine off and cool and with hydraulic actuators relaxed, remove the auxiliary control valve according to the procedure on page 10-8.
2. Place the valve on a bench in a clean work area.

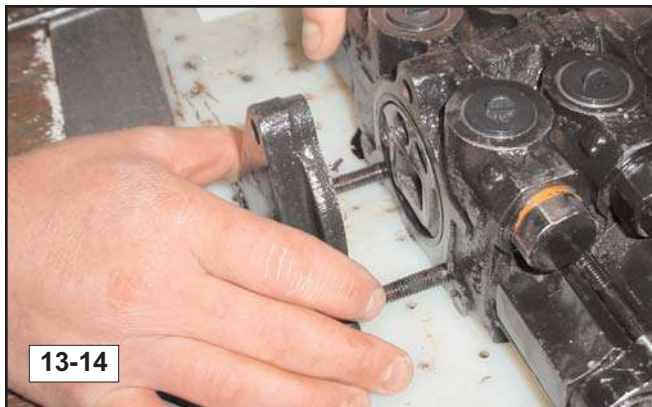

3. Remove the nuts holding the valve stack together, then remove the end cap. (figure 13-13, 13-14)

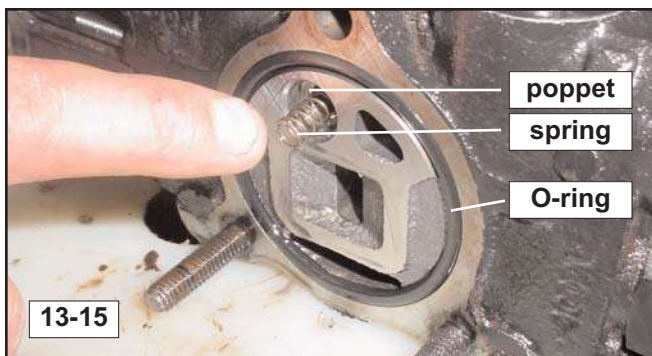

4. Remove each valve section and inspect the seals for damage, replace if necessary. (figure 13-15)

**Note:** Be careful not to lose the spring or poppet that sit inside each valve section, these will be reused.

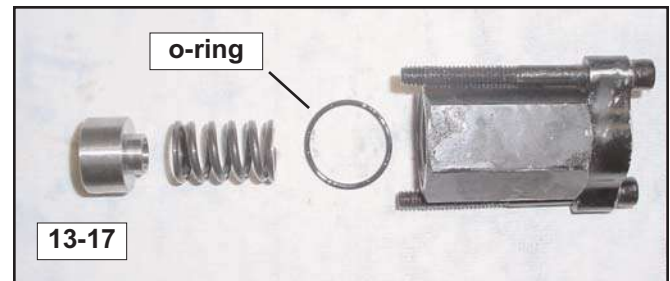
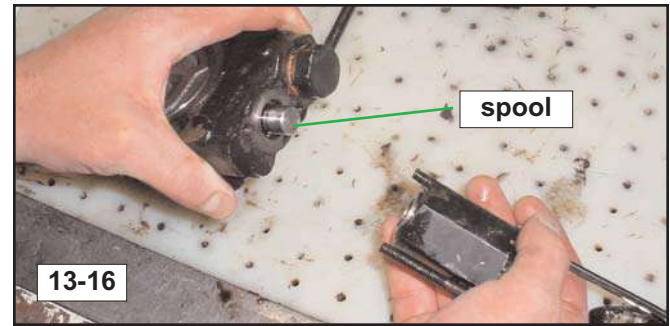

5. Remove each inlet port assembly and inspect the seal, spring, and poppet for damage, replace if necessary. (figure 13-16, 13-17)



6. Once the inlet port covers have been removed, remove the spool and inspect it. If damaged, replace the auxiliary control valve. (fig. 13-18)

**Note:** The spool must be oriented correctly in order for the valve to function. There is a small dimple in the end of each spool. Note the direction it is facing in relation to the valve section upon removal and reinstall it this same way. The valve will not function properly if this spool is installed incorrectly. (fig. 13-18)

### Assembly

1. Install new seals and components in place of the originals as necessary paying close attention to location and orientation to ensure proper function.
2. Thoroughly clean all components to prevent system contamination.
3. Reassemble components by reversing the disassembly process.

## Drive Motor (brake portion) Disassembly

### Required Tools

Allen Wrench/Socket

Rubber Mallet (seal removal if needed)

Screwdriver (blade type) (seal removal if needed)

1. With machine off and cool and with hydraulic actuators relaxed, remove the drive motor from the undercarriage by following the procedure on page 12-5 of this manual.



2. Remove all but four of the allen bolts (on opposite sides of the cover) holding the rear cover onto the drive motor, then back the remaining four out evenly to release the light spring pressure against the cover. (fig. 13-19)



3. Remove the rear cover to expose the brake assembly. (fig. 13-20)



4. Remove the brake spring and shims. Make sure to note the orientation of parts and order of assembly to ensure correct reassembly. (fig. 13-21)



5. Insert an air nozzle into the port closest to the rear of the pump as shown. (fig. 13-22)
6. Cover the opening with a shop cloth and apply moderate force to the top of the brake piston to keep it in place when air is applied. (fig. 13-22)
7. Apply air to the port and the piston should slide upwards so that it can be removed.

**Note:** There is a seal around the outer edge of the piston so it may pop loose rather than gently slide out.



8. Remove the piston from the motor. Inspect the seal for any damage. (fig. 13-23)

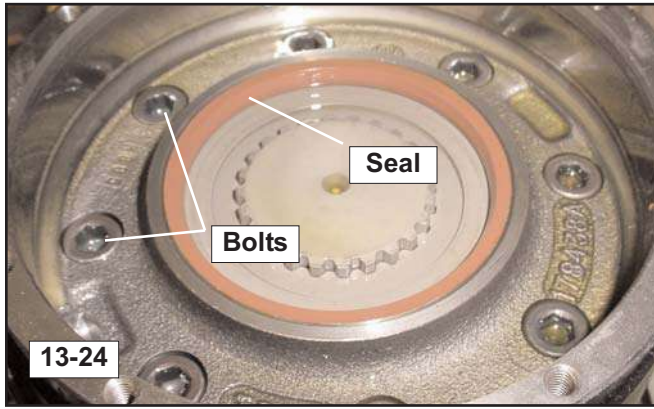

13-24

9. Inspect the seal for any damage. (fig. 13-24)
10. Remove the allen bolts securing the upper casting to the drive motor. (fig. 13-24)



13-25

11. Remove the upper casting from the drive motor to expose the clutch discs. (fig. 13-25)

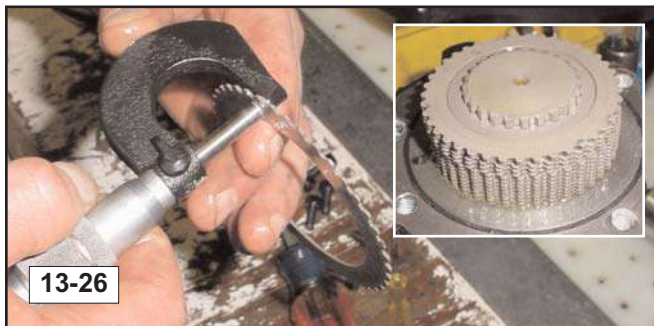

13-26

12. Inspect the discs for discoloration (blueing) or for signs of excessive wear. (fig. 13-26)

**Note:** If any of the individual discs measure less than .015" replace them as a set.

### Assembly

1. Replace worn or damaged components, thoroughly clean all parts, then reassemble the motor by reversing the disassembly procedure.

### Drive Motor (motor portion) Disassembly

#### Required Tools

- Allen Wrench/Socket
- Snap Ring Pliers
- Screwdriver (blade type) (seal removal if needed)



13-27

1. Mark the casing across the parting lines as shown to ensure correct reassembly of the drive motor. (fig. 13-27)

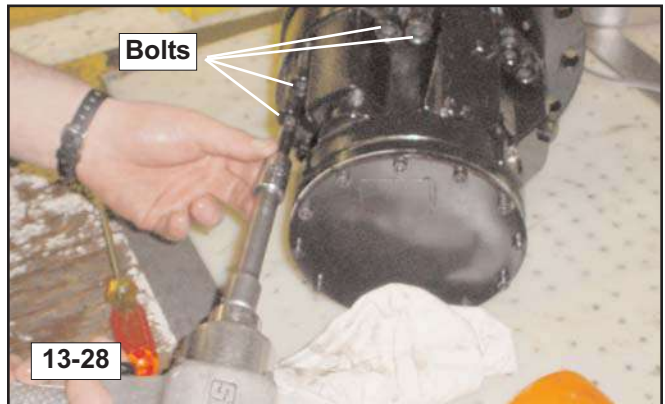

13-28



13-29

2. Remove the allen bolts securing the output end of the drive motor to the main casting and remove it from the motor as shown. (fig. 13-28, 13-29)

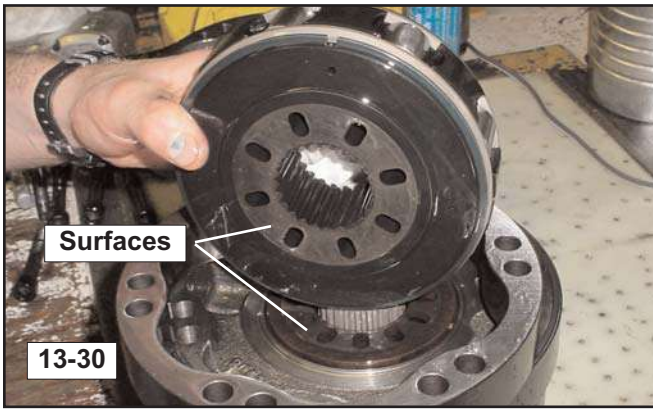

3. Lift and remove the piston block to expose the sealing surfaces. Inspect these surfaces to ensure there is no scratching or abrasion that may affect operation. (fig. 13-30)

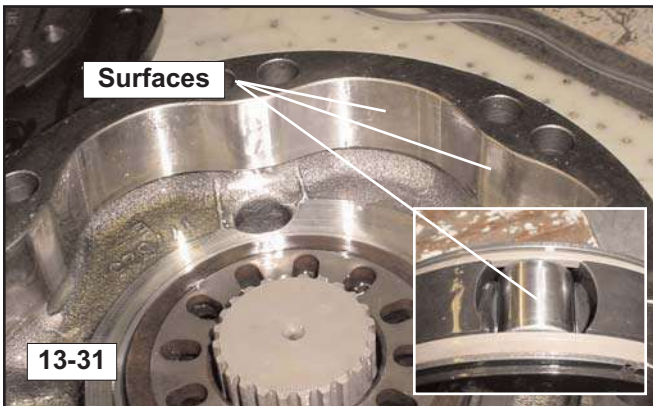

4. Inspect the surfaces of the cam ring and the piston rollers for imperfections. Any damage found indicates a need for component replacement. (fig. 13-31)



5. Using a snap ring pliers, remove the snap and retaining rings on both sides of the piston block to allow for removal and inspection of the block, pistons, piston rings, and rollers. (fig. 13-32)

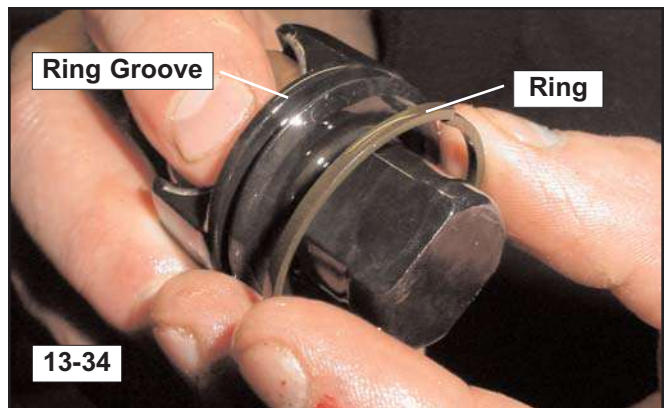

6. Once the snap rings and retainers are removed, slide the piston assemblies out one at a time and inspect them for damage. (fig. 13-33, 13-34)

**Note:** While inspecting the piston assemblies, pay close attention to the piston ring. Look for any signs of damage or cracking. (fig. 13-34)



7. Inspect the rollers and sleeves as well to make sure there are no scratches or other damage that may affect operation. (fig. 13-35)

### Assembly

1. Replace worn or damaged components, thoroughly clean all parts, then reassemble the motor by reversing the disassembly procedure.

## Drive Pump (Drive Relief Valves) Disassembly & Adjustment

<b>Required Tools</b>
Allen Wrench/Socket Combination/Socket wrench

1. With machine off and cool and with hydraulic actuators relaxed, remove the drive pump from the machine by following the procedure in section 10.

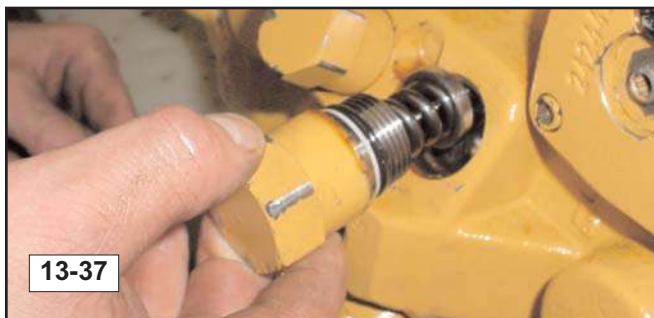

2. Remove the drive pressure relief valves as shown in fig. 13-36 and 13-37.



3. If adjustment is needed (see drive pressure check procedure in section 14), loosen the allen type set screw on the valve. (fig. 13-38)



4. Flip the valve over, then tighten the nut to increase the pressure setting (CW) or loosen it to decrease the pressure setting (CCW). (fig. 13-39)

### Assembly & Test

1. Retighten the locking set screw and reinstall by reversing the disassembly procedure. Retest the pressure through the affected relief to check for proper adjustment. If it is still not correct, repeat the adjustment procedure until correct.

## Drive Pump (Posi-Power Relief Valve) Removal

<b>Required Tools</b>
Combination/Socket wrench



**Note:** The posi-power relief valve is usually a remove and replace item. However, If adjustment is required, please see the posi-power relief valve adjustment procedure on page 14-5 of this manual.

1. Remove the valve from the drive pump as shown in figure 13-40.

### Installation

1. To install, reverse the removal procedure.

## Drive Pump Disassembly

### Required Tools

Combination/Socket wrench  
Allen Wrench/Socket  
Rubber Mallet  
Screwdriver (blade type)  
Snap Ring Pliers



13-41

**Note:** The drive pump is a tandem design where two pumps share one housing. The disassembly and assembly procedures are identical for both pumps.

1. Remove the allen bolts securing the end cap onto the pump. (fig. 13-41)



13-42

2. Remove the end of the pump as an assembly (fig. 13-42)

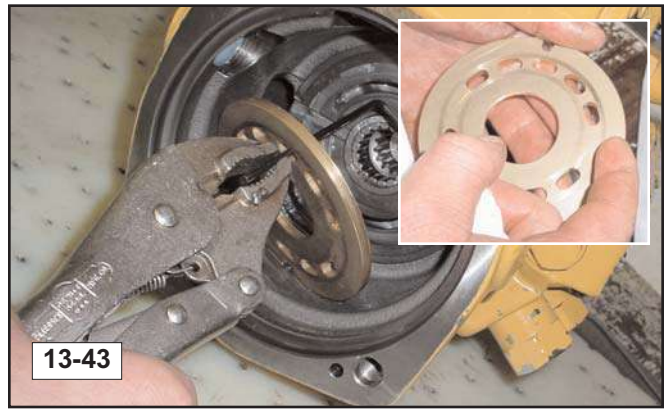

13-43

3. Remove the valve plate and inspect it for damage or wear, specifically, scratches that can be felt with a fingernail. (fig. 13-43)



13-44



13-45

4. Inspect the end of the barrel (face) and the slipper faces for similar scratches. (fig. 13-44, 13-45)

**Note:** To inspect the slipper faces, slide the barrel off of the assembly, then slide the slippers and pistons off of the shaft as an assembly and inspect.

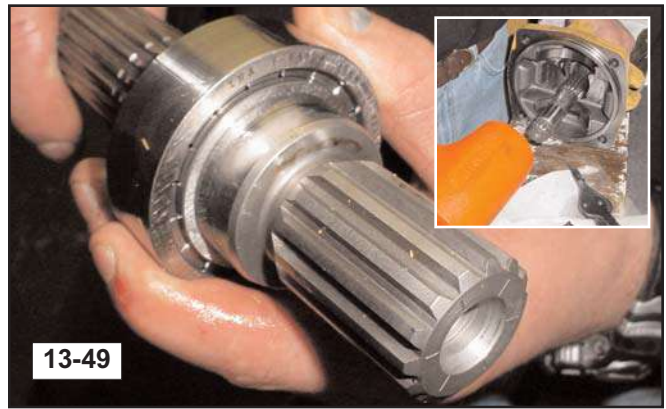
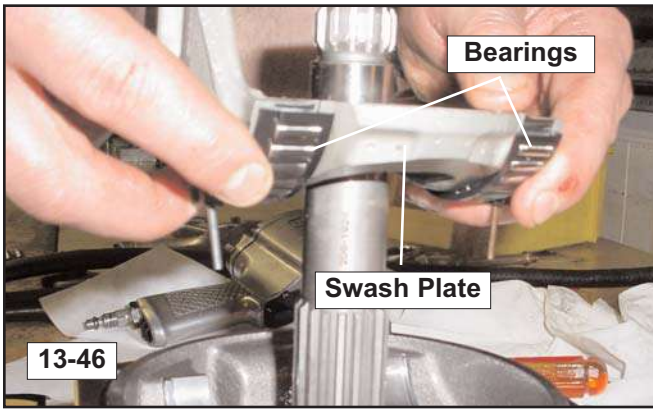

7. Using a rubber mallet, gently tap the shaft and bearing out of the case for inspection or replacement. (fig. 13-49)

5. Remove the swash plate along with the bearings and inspect them for any damage or scratching that could affect operation. (fig. 13-46, 13-47)



6. Remove the snap ring holding the shaft, seal and bearing into the casing, then remove the seal. (fig. 13-48)

**Note:** If you are repairing the existing pump, you will need to replace the outer seal as it will be destroyed upon removal.

## Drive Pump Assembly

### Required Tools

Combination/Socket wrench  
Allen Wrench/Socket  
Rubber Mallet  
Screwdriver (blade type)  
Snap Ring Pliers



1. Using a rubber mallet, gently tap the shaft and bearing into the case until seated. (fig. 13-50)

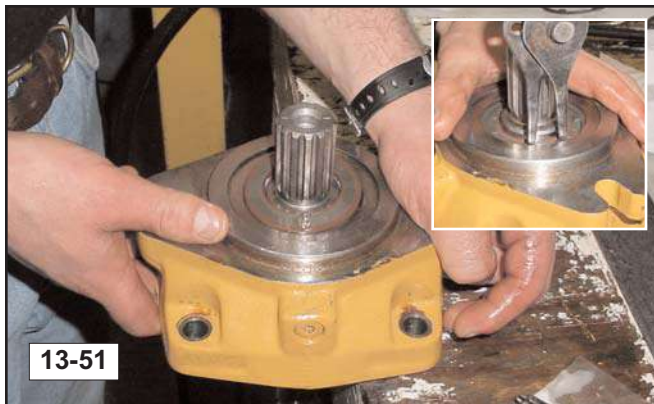

2. Replace the seal with a new one and install taking care not to damage it upon installation. (fig. 13-51)
3. Install the snap ring that secures the shaft, bearing, and seal in place. (fig. 13-51)



4. Flip the assembly over and lay it on a table, then remove the pivot caps from both sides as shown. (fig. 13-52)

**Note:** Behind each cap is a pivot that aligns with the two small pivot wires attached to the swash plate. Remove these from their cavities while installing the swash plate.



5. Assemble the bearing halves to the bottom of the swash plate, orient the pins so that they are vertical and then lower the assembly into place over the shaft. (fig. 13-53)

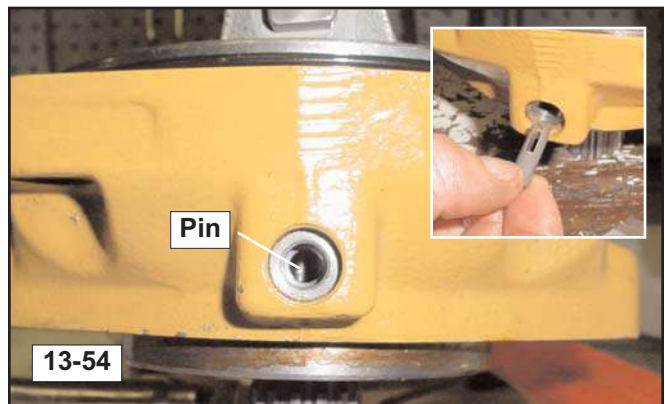

6. Once installed, make sure each pin is centered in its opening, then slide the pivot into the hole so that it mates with the pin. (fig. 13-54)





7. Once the pivots are installed, check to make sure both of them are properly mated with the pins. Using a blade type screwdriver, turn the pivots slightly to the right or left. The swash plate should move with the pivot as each one is turned. If it does not move, repeat step 6, then recheck. Once correct, reinstall the caps to secure them in place (fig. 13-55)

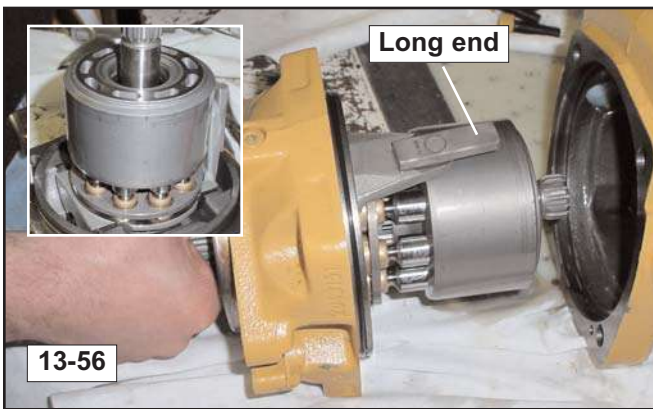

8. Reassemble the piston and barrel portion of the pump as found upon disassembly, then slide it back into the housing. (fig. 13-56, 13-57)

**Note:** Make sure the long end of the swash plate alignment bar is pointing inward to ensure proper operation. (fig. 13-56)



9. Reinstall and tighten the cover bolts to secure the cover. (fig. 13-57)

## Auxiliary Pump Disassembly

<b>Required Tools</b>
<b>Allen Wrench/Socket</b>
<b>Snap Ring Pliers</b>

1. With machine off and cool and with hydraulic actuators relaxed, remove the drive pump from the machine by following the procedure on page 10-1.



2. Remove the bolts that hold the pump end caps onto the housing. (fig. 13-58)

**Note:** Draw a line across the cap and housing parting lines with a permanent marker to help ensure correct part orientation when you reassemble the pump.

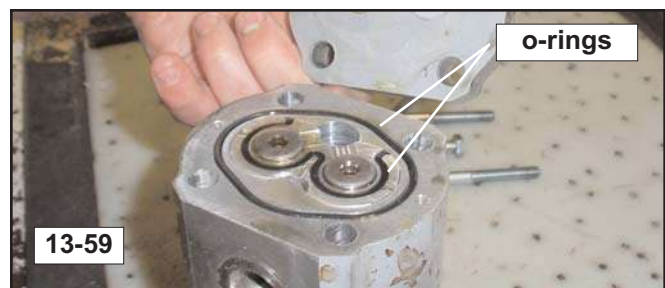

3. Remove the cap on the upper pump. Inspect the o-rings for proper shape and condition. Replace if damaged in any way. (fig. 13-59)



4. Lift the housing off of the lower cap and components. Pay close attention to part order and orientation to aid during reassembly. (fig. 13-60)

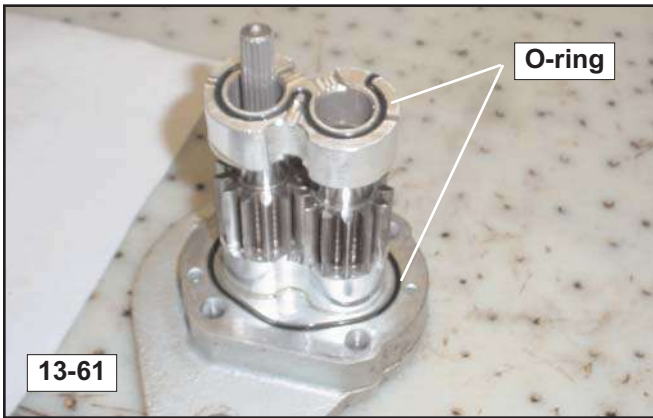

5. Inspect the various o-rings on the lower pump components for any signs of damage, replace if necessary. (fig. 13-61)



**Note:** remove components from the pump carefully and stack them exactly the way they were removed to ensure they go back together correctly. (fig. 13-62)



**Note:** The inside of the pump housing will most likely have very slight wear grooves as wide as the gears where they contact the housing. This is normal and to be expected. However, if the grooves are deeper than .020" or if there is deep scoring or scratching in this area, the pump should be replaced. (fig. 13-63)

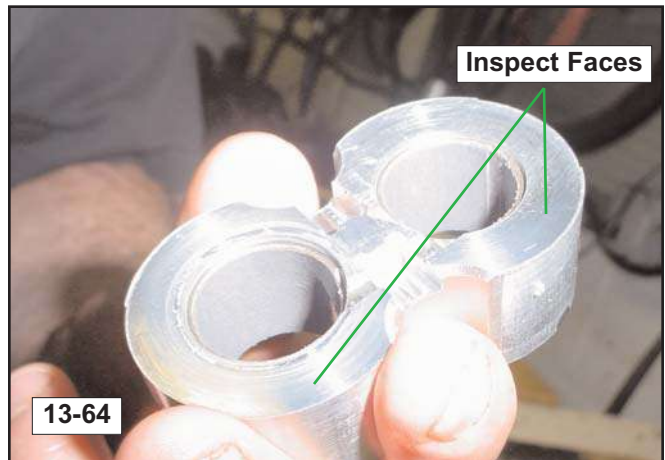

6. Inspect the spacer block faces (both sides) and pump gears for scratches or any other damage that can be felt with a fingernail. If damaged, replace the pump. (fig. 13-64)

**Note:** If there are deep scratches, grooves or signs of scoring on any of the surfaces that parts move, slide or rotate upon, the pump should be replaced.

### Assembly



1. Install new seals and components in place of the worn originals paying close attention to orientation and location to ensure proper operation.
2. Lubricate the gears, inner housing, spacers, and seals with fresh hydraulic oil prior to assembly to avoid damage.
3. Reassemble components by reversing the disassembly process.

**Intentionally left blank**

# 14. Hydraulic Pressure Test & Troubleshooting

## Chapter Overview

This chapter provides hydraulic pressure and flow check, adjustment and troubleshooting procedures.

## Personal Safety

### !WARNING!

**Improper or incomplete maintenance/repair of a Rubber Track Utility Vehicle can be dangerous and may result in machine damage, injury or even death.**

**Do not attempt to perform repair or maintenance on a Rubber Track Utility Vehicle until you have read and fully understood the information in this manual.**

**Refer to the Operation and Maintenance manual for instructions regarding proper machine operation techniques before operating any Rubber Track Utility Vehicle.**

Prior to performing service work on a Rubber Track Utility Vehicle, read and understand Chapter 1 (Product Safety) for personal safety information.

### NOTICE

Hydraulic oil must be at operating temperature to obtain accurate readings during the pressure and flow test procedures described in this section. Start and warm the engine and hydraulic oil prior to performing the test and troubleshooting procedures in this section.

## Contamination Inspection

The hydraulic system can become contaminated when one or more of it's dynamic components fails or begins to wear excessively. This can introduce significant amounts of debris into the hydraulic oil.

In the event of contamination, the defective component(s) must be replaced, the remaining components must be inspected and thoroughly cleaned (if found to be reusable) and the system lines and reservoir must be thoroughly flushed to restore original function.

The hydraulic filter removes contaminants from the oil. Small amounts of debris found on/in the filter are to be expected, but If there is significant metallic debris found in/on the filter, certain components of your hydraulic system may be contaminated. To inspect for contamination, remove the hydraulic filter and inspect it for debris. If contamination is suspected, contact the ASV service department at 1-800-346-4367.

## Hydraulic Pressure Test & Troubleshooting Procedures

Test and troubleshooting procedures are provided for the following Hydraulic system components.

- Charge Pressure Check & Adjustment
- Auxiliary Valve Pressure Check & Adjustment
- Drive Pressure Check & Troubleshooting
- Posi-Power Pressure Check & Adjustment

When checking hydraulic system pressures, you are essentially reading the relief valve settings of each circuit tested. If your hydraulic system and components are functioning properly, your readings should match those specified. If they differ, adjustment and or repair may be required to restore proper function.

**The procedures in this section are listed in the order they are to be performed.** When a pressure issue is suspected, perform these procedures to help diagnose and or repair the problem.

## Charge Pressure Check

Charge pressure is used to prime the various circuits with hydraulic oil for operation. Low charge pressure could lead to sluggish operation of any and all hydraulic functions.

### Required Tools

**Pressure Gauge 0-1000p.s.i.**

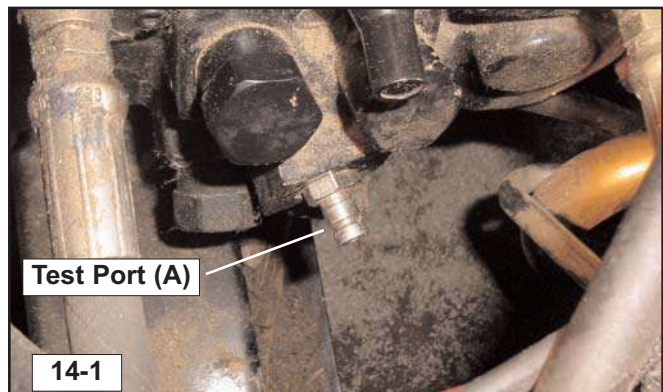

**Note:** The quick coupler (test port A) located in the engine compartment on the driver's side of the drive pump can be used for general pressure checks and troubleshooting.

## 14. Hydraulic Pressure Test & Troubleshooting

1. Attach the gauge to test port A. (fig. 14-1) Route the gauge so that you or an assistant can read it during testing.
2. Make sure any bystanders are clear of moving components, then start the engine.
3. Allow the engine to warm up to operating temperature, then with the engine at idle, check the charge pressure. Record your reading. It should read 420 +/- 30 psi at this test port. If your reading differs, adjustment is necessary.
4. If necessary, adjust the charge relief pressure.  
**To adjust:**
  - a) Remove the engine cover to access the drive pump.
  - b) Locate the charge relief valve on the driver's side of the drive pump. (fig. 14-2)
  - c) Remove the relief valve from the side of the pump as shown in figure 14-3.
  - d) Add shims to increase the pressure setting, or remove shims to decrease the setting until within specification. (figure 14-4)
5. Retest once adjustments have been made to make sure pressure is correct. Readjust as necessary until correct.



## Auxiliary Pressure Check

### Required Tools

Pressure Gauge 0-6000 p.s.i. (& Q/C adapters)

Auxiliary pressure is used to drive hydraulic attachments. Low auxiliary pressure can produce poor performance in attachments while high pressure can cause component damage/failure in the machine or the attachment being utilized.

**Note:** Make sure charge pressure is set correctly prior to testing this function.

1. Start the machine and allow it to warm to operating temperature.
2. Attach the 0-6000psi gauge to the left rear quick coupler, then activate the continuous auxiliary hydraulics switch (press bottom of switch). This action will send oil over relief and you will read the actual pressures required to activate the relief valve for the circuit. Record the pressure reading.

Check your reading against the reading stated below. If your reading differs, an adjustment and or repair may be required.

### Pressure should read:

- 3000 +/- 100 PSI with continuous flow activated.
3. If necessary, adjust the setting on the auxiliary valve inlet relief. (figure 14-7)

### To adjust:

- a) Loosen the jam nut on the top of the relief valve.
- b) Using an allen wrench, turn the adjustment screw clockwise to increase the setting or counter-clock wise to reduce it until within specification.

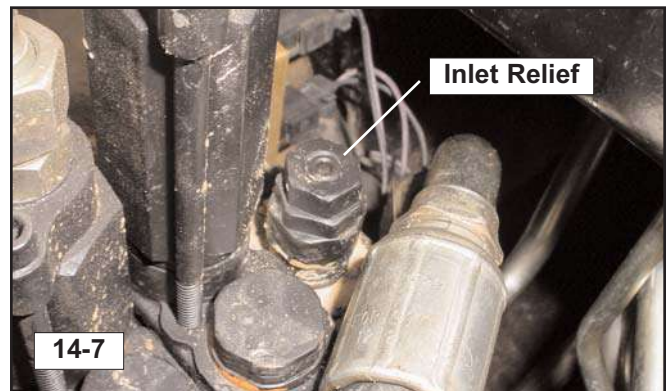

## Drive Pressure Check

### Required Tools

Pressure Gauge 0-6000 p.s.i.

### !WARNING!

This procedure should only be performed if you suspect a drive pump or drive motor is faulty. The procedure is difficult and in performing it, you risk contaminating your hydraulic system if your equipment and working environment is not clean.

Make certain all couplers, fittings and hoses used during this process are clean and free of contaminants that may potentially cause damage to the hydraulic pump and or system components!

Drive pressure is used to turn the drive motors that power your tracks. Low pressure can cause decreased drive motor performance resulting in sluggish maneuvering, decreased speed and or uneven forward or reverse motion.

1. Disconnect the drive hoses at the pump. Cap and plug all openings as shown to allow for the pressure check to be performed and to keep contaminants out of the disconnected hoses. (fig. 14-8)
2. Remove the plug from the port you would like to test and insert a quick coupler similar to the one in the charge pressure test port. (fig. 14-10)

**Note:** There are 4 drive pump test ports. The forward (upper) test ports are shown in figure 14-10 and the reverse (lower) test ports are located similarly near the lower drive ports.

3. Attach the hydraulic gauge to the port(s) you are trying to test and route the gauge so you or an assistant can read the gauge during testing.
4. If tapped into an **upper** port, depress the directional control pedal in an attempt to drive the machine **forward**. This will force oil over relief and give you a reading for the circuit you are tapped into.
5. If tapped into a **lower** port, depress the directional control pedal in an attempt to drive the machine in **reverse**. This will force oil over relief and give you a reading for the circuit you are tapped into.
6. Check all four ports in this same manner and record your readings.

Check your readings against that stated below. If your readings differ, relief replacement and or component repair may be required.

### Pressures should read:

- 5500 PSI when the relief is reached in attempted forward or reverse motion.

### Drive pressure troubleshooting:

7. If one reading is low, swap the relief valve with a similar one and recheck. If the reading improves, replace the faulty relief valve.
8. If two readings are low, but on different circuits (pumps), perform step 7 for both.
9. If both readings are low on one circuit (pump), that portion of the tandem pump is most likely at fault.
10. If all 4 readings are low, it is unlikely that all four relief valves are faulty. Both tandem pumps are most likely not working properly.

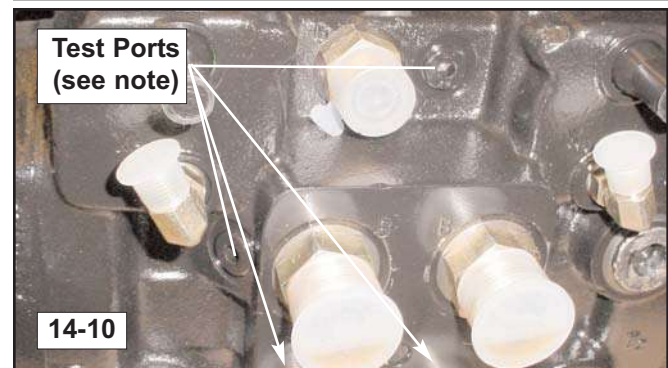
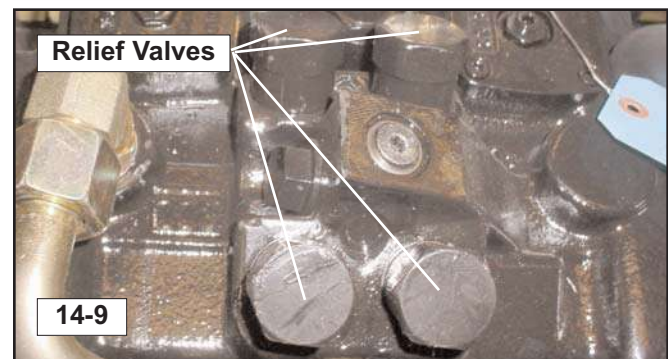
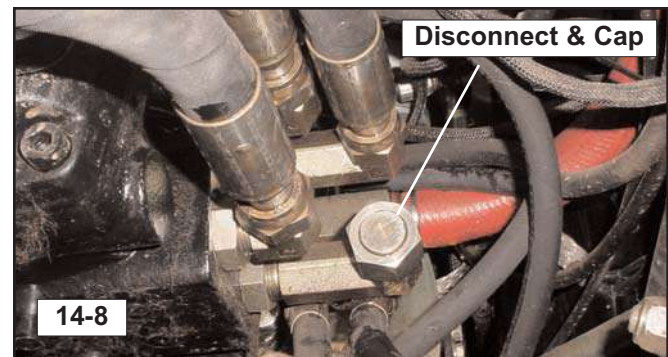

## Posi-Power Pressure Check

Posi-power is a function of the tandem drive pump assembly. The posi-power control reads charge flow (which is directly related to engine rpm) and adjusts drive pump flow to maximize torque and prevent engine stall during high load conditions.

### **!WARNING!**

**This procedure should only be performed if you suspect that the Posi-Power relief valve is faulty. In performing this procedure you risk contaminating your hydraulic system if your equipment and working environment is not clean.**

**Make certain all couplers, fittings and hoses used during this process are clean and free of contaminants that may potentially cause damage to the hydraulic pump and or system components!**

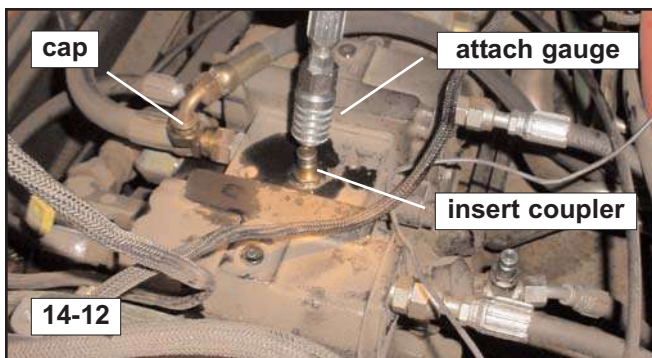
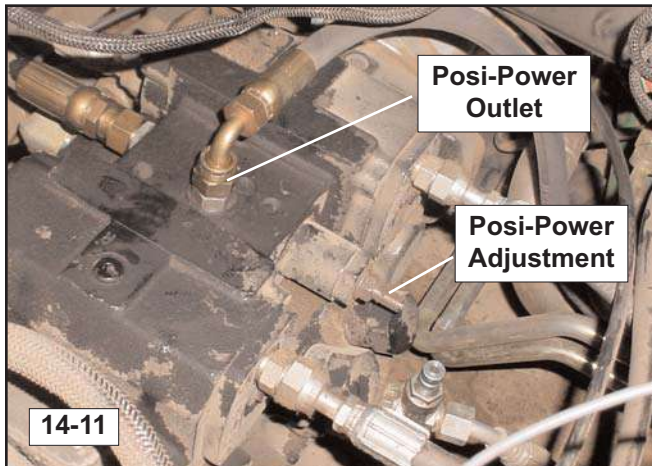

### To check Posi-Power pressure:

1. With the engine off and cool, disconnect and cap the posi-power outlet hose from the port on the top of the drive pump assembly. (figure 14-11)
2. Remove the fitting from the pump assembly and install a quick coupler similar to the one installed in test port A in its place. (fig. 14-12)

3. Attach a gauge to the quick coupler and route it so that you or an assistant can read the gauge during operation.
4. Make sure all bystanders are clear of moving parts and start the engine.
5. At low rpm, posi-power pressure should read 80 +/- 40 psi. (300 +/- 40 at high rpm)
6. If your reading is low, remove the cap and loosen the jam nut on the posi-power adjustment screw and turn it counter clockwise until it stops then retighten the jam nut. (figure 14-11)
  - a) If the screw was already turned completely out and pressure reads lower than specified, the posi-power relief valve is faulty and should be replaced.
  - b) If you were able to turn the screw out, recheck posi-power pressure to see if the reading is now within specification. If it is, the system should function properly. If it did not improve, the posi-power relief valve is faulty and should be replaced.

### To Adjust Posi-Power:

1. Loosen the jam nut and then turn the screw to adjust for more or less posi-power function. (figure 14 -11)
  - a) Turn the screw clockwise to increase function and limit pump flow during high load conditions. (less likely to stall)
  - b) Turn counter-clockwise to decrease function and maximize pump flow during high load conditions. (more likely to stall)
2. Tighten the jam nut while holding the set screw in place to keep desired setting.



**Intentionally left blank**

# 15. Troubleshooting

## Chapter Overview

This chapter contains basic troubleshooting procedures for the SC-50 Rubber Track Utility Vehicle.

Additional troubleshooting aids are provided in Chapter 3 (Circuit Diagrams) and in chapters containing disassembly and assembly procedures for the appropriate component or assembly.

## Personal Safety

### **!WARNING!**

**Improper or incomplete maintenance/repair of a Rubber Track Utility vehicle can be dangerous and may result in machine damage, injury or even death.**

**Do not attempt to perform repair or maintenance on a Rubber Track Utility vehicle until you have read and fully understood the information in this manual.**

**Refer to the Operation and Maintenance manual for instructions regarding proper machine operation techniques before operating any Rubber Track Utility vehicle.**

Prior to performing any type of service work on a Rubber Track Utility vehicle, read and understand Chapter 1 (Product Safety) for personal safety information.

## Visual Inspection

Prior to troubleshooting, walk around the machine and perform an overall visual inspection. Look for missing, loose, worn or broken parts. Pay particular attention to the following items:

- Track tension
- Fluid levels
- Fan belt tension and condition
- Hoses (no visible sign of wear)
- Fittings (no apparent leaks)
- Battery cables
- Fuse panel (fuses in place and operational)
- Controls (for neutral)

A simple visual inspection and operational check can identify many problems without the need for extensive troubleshooting. However, if these checks indicate a problem that requires further analysis, proceed to Troubleshooting.

## Troubleshooting

The most effective way to prevent a malfunction from occurring is to closely follow the recommended maintenance schedule and instructions throughout the life of the machine. However, if a malfunction does occur, finding the problem and fixing it quickly are important. This section covers a select set of symptoms that may occur and suggests possible causes.

### **Problem**

Machine will not crank over.

### **Possible causes:**

1. Continuous flow switch activated.
2. Battery cables loose or corroded.
3. Ignition fuse blown.
4. Main starter fuse blown.
5. Starter relay malfunctioning.
6. Weak or dead battery.
7. Faulty continuous hydraulic flow switch.
8. Faulty ignition switch.
9. Faulty starter.
10. Loose, broken or disconnected wiring at key, relay or starter.
11. Main power fuse (60/80 amp) blown.

## 15. Troubleshooting

---

### **Problem**

Machine cranks, but will not start.

#### **Possible causes:**

1. Fuel tank empty, fuel filter plugged or fuel line restricted.
2. Battery discharged (engine rotates slowly).
3. Injection pump fuse blown.
4. Power relay (B) fuse blown. (50 amp)
5. Faulty power relay (B).
6. Loose, broken or disconnected wiring at injection pump or fuse.
7. Glow plugs not pre-heating (look for black smoke).
  - a) Main glow plug fuse blown.
  - b) Glow plug relay malfunctioning.
  - c) Loose, broken, or disconnected wiring at ignition switch, relay or glow plug ground strip.
  - d) Faulty glow plugs.
8. Faulty ignition switch.
9. Loose, broken or disconnected wiring in starting circuit.
10. Loose, broken or disconnected wiring at fuel shut-down solenoid.
11. Air in fuel system, or defective fuel injection pump.

### **Problem**

Machine starts, but hydraulics will not operate.

#### **Possible causes:**

1. Operator not in seat.
2. Push to operate switch not activated.
3. Seat belt(s) not fastened.
4. Safety relay fuse for seat belt and operator presence safety switches blown.
5. Faulty seat belt safety switch.
  - a) Test for continuity through operator presence and seat belt switches. Adjust or replace as necessary.
6. Loose, broken or disconnected ground wires (check ground connections.)
7. Faulty safety relay.
8. Faulty safety solenoid or safety solenoid spool.
9. Loose, broken or disconnected wiring at fuse, relay, or safety solenoid.
10. Low charge pressure.

### **Problem**

Battery will not accept or maintain charge.

#### **Possible causes:**

1. Loose alternator belt.
2. Alternator fuse blown.
3. Faulty alternator diode.
4. Loose, broken or disconnected wiring at battery, alternator, diode or fuse.
5. Excessive current draw with key in "off" position.
6. Faulty battery.
7. Faulty alternator.
8. Faulty resistor. (on back of fuse panel)

### **Problem**

Hydraulic oil light illuminated; hydraulic system overheating.

#### **Possible causes:**

1. Debris plugging oil cooler, limiting airflow.
2. Low hydraulic oil level.
3. Loose or missing fan belt.
4. Damaged or missing cooling fan blades.
5. Incompatible attachment.
  - a) Attachment must match machine flow capabilities.
  - b) Attachment hose inside diameter must be at least 1/2".
6. Faulty hydraulic oil temperature sending unit.
7. Faulty quick coupler.
8. Cooler bypass relief open.

---

**Note:** Cooler bypass should open at 80 PSI.

---

### **Problem**

Engine coolant temperature light illuminated; engine overheating.

#### **Possible causes:**

1. Low coolant level.
2. Debris plugging radiator, limiting airflow.
3. Damaged or missing cooling fan blades.
4. Loose or missing fan belt.
5. Faulty engine coolant temperature warning light.

# 16. Lubricant & Fuel Specifications

## Chapter Overview

When replacing or replenishing the fluids and lubricants in any ASV Rubber Track Utility Vehicle, use ASV Posi-Lube products. This ensures that the new fluids and lubricants match those originally installed when the machine left the ASV factory. Posi-Lube products were developed for, tested and approved by ASV to assure optimum life and performance in all ASV Rubber Track Equipment, when used as recommended.

## Fluids

### Engine Oil

- ASV Posi-Lube™ Heavy Duty Engine Oil, 10W-30  
**Capacity:** 11.2 U.S. quarts (including filter)  
**P/N:** 0300-767 1 quart  
**P/N:** 0402-838 12 quarts  
**P/N:** 0402-839 1 gallon  
**P/N:** 0402-840 6 gallons

### Engine Anti-freeze/Coolant

- ASV Posi-Lube™ Long-Life 50/50 Antifreeze/Coolant  
**Capacity:** 1.75 U.S. gallons  
**P/N:** 0300-766 1 gallon  
**P/N:** 0402-841 6 gallons

### Hydraulic Oil

- ASV Posi-Lube™ Premium All Season MV Hydraulic Oil  
**Capacity:** 5.125 U.S. gallons (service refill only)  
**P/N:** 0400-253 5 gallons  
**P/N:** 0402-833 55 gallons

### Grease (general-use)

- ASV Posi-Lube™ Multi-Purpose EP Lithium Grease  
**P/N:** 0300-769 1 tube  
**P/N:** 0402-844 10 tubes  
**P/N:** 0402-834 40 tubes

If Posi-Lube™ products are not available, use high quality substitutions that meet or exceed factory installed fluid specifications.

## Fuel Specifications

In North America, diesel fuel, distilled from crude oil, identified as No. 1-D or No. 2-D in “ASTM D975” generally meet machine requirements.

**Intentionally left blank**

# 17. Service Aids & Supplements

## General Torque Specifications

### Inch Fasteners

<u>Thread Size</u>	<u>Standard Torque</u>
1/4"	9 +/- 2 lb ft
5/16"	18 +/- 4 lb ft
3/8"	35 +/- 7lb ft
7/16"	50 +/- 11 lb ft
1/2"	75 +/- 15 lb ft
9/16"	120 +/- 22 lb ft
5/8"	160 +/- 30 lb ft
3/4"	275 +/- 37 lb ft
7/8"	460 +/- 60 lb ft
1"	660 +/- 75 lb ft
1-1/8"	960 +/- 110 lb ft
1-1/4"	1320 +/- 150 lb ft
1-3/8"	1780 +/- 220 lb ft
1-1/2"	2280 +/- 260 lb ft

### Metric Fasteners

<u>Thread Size</u>	<u>Standard Torque</u>
M6	12 +/- 3 Nm
M8	28 +/- 7 Nm
M10	55 +/- 10 Nm
M12	100 +/- 20 Nm
M14	160 +/- 30 Nm
M16	240 +/- 40 Nm
M20	460 +/- 60 Nm
M24	800 +/- 100 Nm
M30	1600 +/- 200 Nm
M36	2700 +/- 300 Nm

---

**Terex Construction Americas**

8800 Rostin Road

Southaven, MS 38671

**(888)-201-6008**

**(662)-393-1800**

**www.terex.com**