

Language: English
Geographic Region: All
Serial Number Range: SN All



SR70

Service Repair Manual

This manual is complements of
TrackLoaderParts.com

The world's best source for ASV parts.



Table of Contents

1. Product Safety		3. Circuit Diagrams	
Chapter Overview	1-1	Chapter Overview	3-1
Safety Messages	1-1	Hydraulic Charge Circuit	3-1
Information Messages	1-1	Hydraulic Auxiliary Circuit	3-2
Basic Precautions	1-1	Hydraulic Drive Circuit	3-3
Safety Labels	1-1	Lift Arm Control Valve	3-4
Protective Equipment	1-2	Hydraulic Pilot Generation Solenoid Block	3-5
Entering and Exiting	1-2	Electrical Attachment Outlet	3-6
Lifting	1-2	Drive Control (line routing)	3-7
Hot Fluids and Components	1-2	Lift Arm Control (line routing)	3-8
Corrosion Inhibitor	1-2		
Batteries	1-2	4. Maintenance	
Pressurized Items	1-2	Chapter Overview	4-1
Repair	1-3	Personal Safety	4-1
Work Tools	1-3	Lift-Arm Brace	4-1
Asbestos Information	1-4	Tilt-up Cab	4-2
Machine Labels and Decals	1-4	Jacking Procedure	4-2
Product Identification Number	1-4	Grease Fittings	4-3
Engine Serial Number	1-4	Undercarriages	4-3
Machine Label and Decal Examples	1-5	Track Tension	4-4
		Drive Sprocket Rollers	4-5
2. Technical Specifications		Track Removal	4-6
Specifications (SR-80)	2-1	Track Installation	4-8
Engine	2-1	Air Cleaner	4-10
Transmission	2-1	Fuel Filter	4-11
Drive Pumps	2-1	Water Separator	4-11
Charge Pump	2-1	Accessory Belt Tension	4-12
Drive Motors	2-1	Fan Belt Removal/Installation	4-13
Pilot Controls	2-1	A/C Belt Removal/Installation	4-13
Auxiliary Pump	2-1	Engine Oil/Filter Change	4-14
Lift Arm Control Valve	2-1	Engine Oil Specifications	4-15
Oil Cooler	2-1	Oil Level Check	4-15
Critical Torque Specifications	2-1	Hydraulic Fluid/Filter Change	4-16
Cycle Times	2-1	Radiator/Oil Cooler (cleaning)	4-17
Service Tools	2-1	Engine (cleaning)	4-17
Specifications (SR-70)	2-2	Case Drain Filter	4-18
Engine	2-2	Fuse Panel	4-18
Transmission	2-2	Maintenance Schedule	4-19
Drive Pumps	2-2		
Charge Pump	2-2	5. Machine Controls and Instrumentation	
Drive Motors	2-2	Chapter Overview	5-1
Pilot Controls	2-2	Machine Controls	5-1
Auxiliary Pump	2-2	Loader Control	5-1
Lift Arm Control Valve	2-2	Drive Control	5-1
Oil Cooler	2-2	Throttle	5-1
Critical Torque Specifications	2-2	Instrumentation	5-1
Cycle times	2-2	Switches	5-2
Service Tools	2-2		

6. Operator Enclosure		
Chapter Overview	6-1	
Personal Safety	6-1	
Machine Preparation	6-1	
Removal & Installation	6-1	
Door Gas Spring	6-1	
Removal Procedure	6-1	
Installation Procedure	6-1	
Pillar Switch Panels	6-2	
Removal Procedure	6-2	
Installation Procedure	6-2	
Gauge Clusters	6-3	
Removal Procedure	6-3	
Installation Procedure	6-3	
Seat	6-4	
Removal Procedure	6-4	
Installation Procedure	6-4	
Interior Side Panel, LT	6-4	
Removal Procedure	6-4	
Installation Procedure	6-5	
Interior Side Panel, RT	6-5	
Removal Procedure	6-5	
Installation Procedure	6-5	
Interior Panel, Rear	6-6	
Removal Procedure	6-6	
Installation Procedure	6-6	
Lap Bar Assist Gas Spring	6-6	
Removal Procedure	6-6	
Installation Procedure	6-6	
7. Chassis and Fuel Tank		
Chapter Overview	7-1	
Personal Safety	7-1	
Machine Preparation	7-1	
Removal & Installation	7-1	
Fuel Sending Unit	7-1	
Removal Procedure	7-1	
Installation Procedure	7-2	
Fuel Tank	7-2	
Removal Procedure	7-2	
Installation Procedure	7-3	
Footwell	7-4	
Removal Procedure	7-4	
Installation Procedure	7-4	
Foot Throttle Assembly	7-5	
Removal Procedure	7-5	
Installation Procedure	7-5	
Hood Assembly	7-5	
Removal Procedure	7-5	
Installation Procedure	7-6	
8. Radiator and Oil Cooler		
Chapter Overview	8-1	
Personal Safety	8-1	
Machine Preparation	8-1	
Removal & Installation	8-1	
Fan Guard	8-1	
Removal Procedure	8-1	
Installation Procedure	8-2	
Fan & Shroud	8-2	
Removal Procedure	8-2	
Installation Procedure	8-3	
Radiator/Oil Cooler	8-3	
Removal	8-3	
Installation	8-4	
9. Hydraulic Reservoir		
Chapter Overview	9-1	
Personal Safety	9-1	
Machine Preparation	9-1	
Removal & Installation	9-1	
Hydraulic Reservoir	9-1	
Removal Procedure	9-1	
Installation Procedure	9-7	
Suction Screen	9-8	
Removal Procedure	9-8	
Installation Procedure	9-8	
10. Lift Arm/Drive Controls		
Chapter Overview	10-1	
Personal Safety	10-1	
Machine Preparation	10-1	
Removal & Installation	10-1	
Joystick	10-1	
Removal Procedure	10-1	
Installation Procedure	10-3	
Lift Arm Float Magnet	10-3	
Removal	10-3	
Installation	10-3	
Lift Arm Control Valve	10-4	
Removal	10-4	
Installation	10-4	
11. Hydraulic Pumps/Motors		
Chapter Overview	11-1	
Personal Safety	11-1	
Machine Preparation	11-1	
Removal & Installation	11-1	
Charge Pump	11-1	
Removal Procedure	11-1	
Installation Procedure	11-2	
Auxiliary Pump	11-3	
Removal Procedure	11-3	
Installation Procedure	11-4	
Tandem Drive Pump	11-4	
Removal Procedure	11-4	
Installation Procedure	11-5	
Drive Motor	11-6	
Removal Procedure	11-6	
Installation Procedure	11-8	

12. Engine

Chapter Overview	12-1
Personal Safety	12-1
Removal & Installation	12-1
Battery	12-1
Removal Procedure	12-1
Installation Procedure	12-2
Exhaust System	12-2
Removal Procedure	12-2
Installation Procedure	12-4
Air Cleaner	12-4
Removal Procedure	12-4
Installation Procedure	12-5
Engine	12-5
Removal Procedure	12-5
Installation Procedure	12-7

13. Undercarriage

Chapter Overview	13-1
Personal Safety	13-1
Machine Preparation	13-1
Removal & Installation	13-1
15" Idler Wheel (SR-80)	13-1
Removal Procedure	13-1
Installation Procedure	13-2
15" & 10" wheel (SR-70)	13-3
Removal & Installation Procedures	13-3
10" Bogie Wheel & Hub (SR-80)	13-3
Removal & Service Procedure	13-3
Idler Hub	13-8
Removal & Service Procedure	13-8

14. Lift Arm Components

Chapter Overview	14-1
Personal Safety	14-1
Machine Preparation	14-1
Removal & Installation	14-1
Lift Cylinder	14-1
Removal Procedure	14-1
Installation Procedure	14-3
Bucket/Tilt Cylinder	14-3
Removal Procedure	14-3
Installation Procedure	14-5
Q/C Block PRV	14-5
Removal Procedure	14-5
Installation Procedure	14-5

15. Quick Attach

Chapter Overview	15-1
Personal Safety	15-1
Machine Preparation	15-1
Removal & Installation	15-1
Locking Pin	15-1
Removal Procedure	15-1
Installation Procedure	15-2
Pivot Pin	15-3
Removal Procedure	15-3
Installation Procedure	15-3

16. Hydraulic Component Service

Chapter Overview	16-1
Personal Safety	16-1
Disassembly & Assembly	16-1
Hydraulic Cylinder	16-1
Disassembly Procedure	16-1
Assembly Procedure	16-3
Lift Arm Control Valve	16-4
Disassembly Procedure	16-4
Assembly Procedure	16-6
Drive Motor (brake portion)	16-6
Disassembly Procedure	16-6
Assembly Procedure	16-7
Drive Motor (motor portion)	16-8
Disassembly Procedure	16-8
Assembly Procedure	16-9
Drive Pump (Drive Relief Valves)	16-9
Disassembly & Adjustment	16-9
Posi-Power Relief Valve	16-9
Drive Pump	16-10
Disassembly Procedure	16-10
Assembly Procedure	16-12
Auxiliary Pump	16-14
Disassembly Procedure	16-14
Assembly Procedure	16-15

17. Hydraulic Pressure & Flow

Chapter Overview	17-1
Personal Safety	17-1
Contamination Inspection	17-1
Pressure/Flow Test and Troubleshooting	17-1
Charge Pressure Check & Adjust	17-1
Auxiliary Pressure Check & Adjust	17-3
Lift Arm Pressure Check	17-4
Drive Pressure Check	17-4
Troubleshooting	17-5
Posi-Power Pressure Check & Adjust	17-5
Auxiliary Flow Test	17-6
Troubleshooting	17-7

18. Troubleshooting

Chapter Overview	18-1
Personal Safety	18-1
Visual Inspection	18-1
General Troubleshooting Scenarios	18-1
Engine/Machine Troubleshooting	18-3

19. Lubricant and Fuel Specifications

Chapter Overview	19-1
Fluids & Fuel Specifications	19-1

20. Service Aids and Supplements

General Torque Specifications	20-1
Electrical Schematic	20-2
Hydraulic Schematic	20-3

1. Product Safety

Chapter Overview

This chapter contains product safety information for the SR-70/80 Rubber Track Loaders. Read and understand all product safety information before attempting to service any Rubber Track Loader.

Safety Messages

Safety messages are included in this document to serve as warnings of potentially dangerous conditions. Failure to follow their instructions could result in injury or death.

These messages are identified by the headings: **!DANGER!.....!WARNING!.....!CAUTION!**.

The messages are to be understood as: **Attention! Your Safety Is Involved!**

The information that follows each heading describes the potential hazard and the precautions necessary to protect yourself and others from injury. Instructions may be written or pictorially presented.

!DANGER!

This symbol is used to alert service personnel of an imminently hazardous situation that will result in serious injury or death.

!WARNING!

This symbol is used to alert service personnel of a potentially hazardous situation that could result in serious injury or death.

!CAUTION!

This symbol is used to alert service personnel of an unsafe practice that could result in injury.

Information Messages

Information messages are also included in this document to supplement the instructions and photographs in each chapter. These messages are identified by the labels **NOTICE** or **Note**.

NOTICE

This label is used to alert service personnel of a situation that could lead to equipment or machine damage.

Note: This label is used to provide important additional information, further explanation, comments or to stress the importance of a topic.

The person(s) in charge of servicing a Rubber Track Loader may be unfamiliar with many of the systems on the machine. This makes it especially important to use caution when performing service tasks. Familiarize yourself with the affected system(s) and components before attempting any type of maintenance or service.

It is not possible to anticipate every potential hazard. The safety messages included in this document and displayed on the machine are not all-inclusive. They are intended to make you aware of potential risks and encourage a safe approach to performing service work. If you use a tool, procedure, work method or operating technique that is not specifically recommended by ASV, you must satisfy yourself that it is safe for you and others. You must also ensure that the machine will not be damaged or be made unsafe by the operation, lubrication, maintenance or repair procedures that you choose.

Basic Precautions

!WARNING!

Improper or incomplete maintenance/repair of a Rubber Track Loader can be dangerous and may result in machine damage, injury or even death.

Do not attempt to perform any type of repair or maintenance on a Rubber Track Loader until you have read and fully understood the information in this manual.

Refer to the Operation and Maintenance manual for instructions regarding proper machine operation techniques before operating any Rubber Track Loader.

Following is a list of basic precautions that should always be observed.

Safety Labels

Safety labels are displayed in various places throughout the machine to serve as warnings of potentially dangerous conditions. Read and understand all "Safety" labels on any Rubber Track Loader before attempting to operate, maintain or repair it. Replace any damaged, illegible or missing labels as necessary.

Protective Equipment

Always wear appropriate protective equipment for working conditions when working on or around a Rubber Track Loader. Wear hard hats, protective glasses, safety shoes and any other equipment necessary to ensure your safety and the safety of others as you work. In particular, wear protective glasses when pounding on any part of the machine or its work tool with a hammer or sledge. Do not wear loose clothing or jewelry that can catch on components and cause injury. If welding is required, use welding gloves, helmet (UV eye protection), apron, boots and any other protective clothing necessary to ensure your safety and the safety of others while welding. Avoid wearing flammable or heat sensitive clothing while performing tasks that involve welding.

Entering and Exiting

Always use steps and handholds when entering or exiting a Rubber Track Loader. Clean any mud or debris from steps or work platforms before using them. Always face the machine when using steps and handholds. When it is not possible to use the designed entry/exit system, utilize ladders, scaffolds, or work platforms to safely gain access to the machine.

Lifting

Use a hoist when lifting components that weigh 23 kg (50 lb) or more, to avoid back injury. Make sure all chains, hooks, slings, etc., are in good condition and are of the correct capacity. Be sure hooks are positioned correctly and equipped with a spring latch. Lifting eyes are not to be side loaded during a lifting operation.

Hot Fluids and Components

Stay clear of hot components and system fluids of the engine, exhaust, radiator/oil cooler and hydraulic lines/tubes. Also, use caution when removing fill caps, breathers and plugs on the machine. Hold a rag over the cap or plug to prevent being sprayed or splashed by liquids under pressure. Be especially careful if the machine has been operated recently, fluids may still be hot. To ensure your safety, allow the machine to cool before attempting any service procedure that involves hot fluids or components.

Corrosion Inhibitor

Corrosion inhibitor contains alkali. Avoid contact with eyes. Avoid prolonged or repeated contact with skin. Do not take internally. In case of contact, wash skin immediately with soap and water. For eyes, flush with large amounts of water for at least 15 minutes. Call Physician. Keep out of reach of children.

Batteries

Do not smoke when inspecting the battery electrolyte level. Never disconnect any charging unit circuit or battery circuit cable from the battery when the charging unit is operating. A spark can cause an explosion from the flammable vapor mixture of hydrogen and oxygen that is released from the electrolyte through the battery outlets. Do not let electrolyte solution make contact with skin or eyes. Electrolyte solution is an acid. In case of contact, immediately wash skin with soap and water. For eyes, flush with large amounts of water for at least 15 minutes. Call Physician. Keep out of reach of children.

Pressurized Items

1. Do not use hands or any other body part to check for fluid leaks in the hydraulic system. Always use a solid material like wood or metal to check for this type of leak. Leaking fluid under pressure can penetrate body tissue. Fluid penetration can cause serious injury and even death. If fluid is injected into your skin, get treatment immediately. Seek treatment from a doctor that is familiar with this type of injury.
2. Relieve pressure from the hydraulic system before disconnecting or removing any lines, fittings or related items. Do this by relaxing all hydraulic actuators. If the lift arms are raised, make sure they are securely braced. Be alert for possible pressure release when disconnecting any device from a pressurized system.
3. Lower the lift arms before performing any work on the machine. If this cannot be done, make sure they are securely braced to prevent them from dropping unexpectedly during service.
4. Loose or damaged fuel, oil, hydraulic, lines, tubes and hoses can cause fires. Do not bend or strike high pressure lines or install ones that have been bent or damaged. Check lines, tubes and hoses carefully. See item 1 for precautions on checking for fluid leaks.
5. Pressurized air or water can also cause injury. When pressurized air or water is used for cleaning, wear a protective face shield, protective clothing, and protective shoes. The recommended maximum air pressure for cleaning purposes is 205 kPa (30 psi). When using a pressure washer, keep in mind that nozzle pressures are typically very high. Generally, pressures are well above 13790 kPa (2000 psi). Follow all recommended practices provided by the pressure washer manufacturer.

Repair

!WARNING!

Accidental machine starting can cause injury or even death to personnel working on a Rubber Track Loader.

As a precaution, disconnect the battery cables from the battery terminals, tape the battery clamps and remove the key from the ignition switch prior to performing any service work on a Rubber Track Loader.

Place a “Do Not Operate” tag prominently on the machine to inform personnel that the machine is being serviced.

1. Disconnect the battery and discharge any capacitor before beginning work on a machine. Attach a **Do Not Operate** tag in the cab to alert any operator that service is in progress.
2. If possible, make all repairs with the machine parked on a level, hard surface. Use blocks to prevent the machine from rolling while working on or under the machine.
3. Do not work on or under any machine that is supported only by a hydraulic jack or hoist. Always use some sort of mechanical support to ensure that the machine will not fall. ASV jack stands work well to support the machine while performing maintenance or repair work.
4. Make sure the work area around the machine is safe and make yourself aware of any hazardous conditions that may exist. If the engine needs to be started inside an enclosure, make sure that the engine's exhaust is properly vented.
5. Be sure all protective devices including guards and shields are properly installed and functioning correctly before beginning any service task. If a guard or shield must be removed to perform the repair work, use extra caution.
6. Always use the appropriate tools for the work to be performed. Tools should be in good condition and you should understand how to use them properly before performing any service work.
7. When replacing fasteners, use parts of equivalent grade and size. Do not use a lesser quality fastener if replacements are necessary.
8. Be prepared to stop an engine if it has been recently overhauled or the fuel system has been recently serviced. If the engine has not been assembled correctly, or if the fuel settings are not correct, the engine can possibly overspeed and cause bodily injury, death or property damage. Be prepared to shut off the fuel and air supply to the engine in order to stop the engine.
9. Be careful when removing cover plates. Gradually back off the last two bolts or nuts located on opposite sides of the cover. Then, pry the cover loose to relieve any spring or other pressure before removing the last two nuts or bolts completely.
10. Repairs requiring welding should be performed only by personnel adequately trained and knowledgeable in welding procedures and with the guidance of appropriate reference information. Determine the type of metal being welded and select the correct welding procedure and filler material to provide a weld that is as strong or stronger than the original weld.
11. Take precautions to avoid damaging wiring during removal and installation operations. Carefully route wires so that they will not contact sharp corners, objects or hot surfaces during operation.
12. When performing service that requires the lift arms to be in the raised position, always utilize the lift arm brace located on the rear of the loader tower.
13. Relieve hydraulic system pressure by relaxing all hydraulic actuators prior to attempting any hydraulic maintenance or repair.
14. Always tighten connections to the correct torque specification. Make sure that all shields, clamps and guards are installed correctly to avoid excessive heat, vibration or unwanted contact between parts during operation. Shields that protect exhaust components from oil spray in event of a line, tube or seal failure must be correctly installed.
15. Do not operate a machine if any rotating part is damaged or contacts other parts during operation. Any high speed rotating component that has been damaged or altered should be checked for balance before reusing. Make sure all protective devices, including guards and shields, are properly installed and functioning correctly before starting the engine or operating the machine.

Work Tools (Attachments)

Only use work tools that are recommended by ASV.

Make sure that all necessary guards and protective equipment are in place and functioning prior to operating any work tool.

1. Product Safety

Wear protective glasses and protective equipment as required by conditions or as recommended in the work tool's operation manual.

Ensure that all personnel are far enough away from the work area so they will not be struck by flying objects.

Stay clear of the cutting edges, pinching surfaces or crushing surfaces of the work tool while performing any work tool maintenance, testing or adjustments.

Asbestos Information

Equipment and replacement parts shipped from the manufacturer are asbestos free. When replacement parts are required, use only genuine manufacturer's replacement parts

Use caution when handling replacement parts from another supplier if these parts contain asbestos. Avoid inhaling dust that might be generated when handling these components or when handling asbestos debris. Inhaling this dust can be hazardous to your health.

The components that may contain asbestos fibers are lining material, and some gaskets. The asbestos that is used in these components is usually encased in a resin or sealed in some way. Normal handling is not hazardous unless airborne dust containing asbestos is generated.

If dust that may contain asbestos is present, there are several guidelines that should be followed.

1. Never use compressed air for cleaning. Avoid brushing or grinding materials that contain asbestos. Use a wet method to clean up asbestos debris. A vacuum that is equipped with the high-efficiency particulate air filter (HEPA filter) can also be used.
2. Use exhaust ventilation on permanent machining jobs.
3. Wear an approved respirator if there is no other way to control the dust.
4. Comply with applicable rules and regulations for the work place. In the USA, use Occupational Safety and Health Administration requirements. These OSHA requirements can be found in 29 CFR 1910.1001.
5. Obey environmental regulations for disposal of asbestos.

6. Stay away from areas that might have asbestos particles in the air.

!WARNING!

When replacement parts are required for your machine, use only genuine ASV replacement parts or parts that meet or exceed original specifications including, but not limited to physical dimensions, type, strength and material.

Installing lesser components can lead to premature failures, product damage, personal injury or death.

Machine Labels and Decals

Labels and decals placed on the machine provide safety information and operating instructions. Familiarize yourself with the location and significance of these labels to ensure your safety.

Product Identification Number

The Product Identification Number (PIN) is located on the front of the cab enclosure in the lower right corner. (figure 1-1). Always provide the PIN when contacting the dealer about parts, service, warranty or accessories. No warranty claims will be processed unless the PIN is provided.



Engine Serial Number

The engine serial number is located on the top of the engine valve cover near the rear of the machine. (figure 1-2)

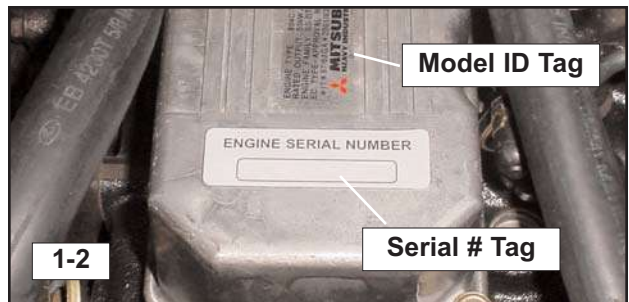

Machine Label and Decal Examples

Examples of the labels and decals displayed on the machine are shown on this page.

⚠ DANGER ⚠



Keep out from under raised lift arms!

Do not go beneath raised lift arms unless the lift arm brace has been properly installed. See operation and maintenance manual for installation procedure.

Failure to observe or comply with warnings may result in serious injury or even death. 2045-466

2-Speed
(if equipped)

To engage:
Press the button located on the front of the right joystick control.

To disengage:
Press the button a second time.

⚠ WARNING ⚠

Brushcutting

Brushcutting, mowing or operations that generate airborne debris can cause fires.

With the engine off and cool:

1. Inspect the engine compartment and any other areas containing hot or rotating parts
2. Thoroughly clean these areas as often as necessary to avoid combustion.

Failure to do so could result in fire that may cause machine damage, personal injury, or even death. 2045-468

⚠ WARNING ⚠

Entering & Exiting

Maintain 3-point contact with step and hand rails.

Pre-Start Checklist

1. Operator seated in cab.
2. Seat belt fastened.
3. Lap bar pivoted down.
4. Joystick controls in neutral position.
5. Quick attach switch in locked position.
6. High & low flow auxiliary switches off.

Engine Warm-Up

Allow the engine to warm up prior to operation.

Carrying Loads

Carry loads low. Load, unload and turn on level ground.

Inclines

Travel with heaviest end of machine facing uphill.

Riders

Riders not permitted.

Work Platform

Never use a work tool as a work platform.

Disclaimer

Failure to observe and comply with the warnings listed above may result in machine damage, personal injury, or even death. 2045-469

⚠ WARNING ⚠

NEVER GO BENEATH UNSECUED LIFT ARMS

1. Remove any attachment from the machine.
2. Have an assistant remove the lift arm brace from its stowed position.
3. Start the engine and carefully raise the lift arms.
4. Have the assistant install the brace around the exposed portion of the lift cylinder rod.
5. Have the assistant secure the brace to the rod with the retaining pins, then stand clear.
6. Slowly lower the lift arms until they come to rest on the brace.
7. Shut the engine off and carefully exit the machine.
8. Reverse this procedure to lower and re-secure the lift arm brace.

Follow instructions closely!
Failure to install lift arm brace correctly may result in personal injury or death. 2045-646

WARNING

CAUTION

Keep away from tracks while machine is in motion. Serious personal injury or even death may result.

Inspect undercarriages daily for accumulation of debris. Build-up of debris may shorten component life and decrease machine performance. 2045-467

⚠ DANGER ⚠

Prior to Operating

Read and fully understand the operation and maintenance manual prior to operating this machine.

Operating Position

Never operate the machine with any part of your body protruding out of the operator enclosure.

Failure to do so may result in serious injury or even death. 2045-472

2. Technical Specifications & Service Tools

SR-80 Specifications

Engine

- Model: Perkins 804C-33T
- Displacement: 3.3 liter
- Gross horsepower: 80.5 hp (60 kW)
- Torque: 186 lb-ft. (253 Nm)
- Idle rpm: 1000 (low idle), 2600 (high idle)
- Average water /thermostat temperature: 190°F, 87.8°C

Transmission

- Model: Cat A22VG45 tandem (Rexroth)

Drive Pumps

- Displacement: 2.7459 in³/rev (45 cc/rev)
- Relief pressure: 5500 psi (380 bar)
- Flow: 30.91 gpm (117 lpm) @ 2600 rpm (per pump)

Charge Pump

- Displacement: 1.373 in³/rev (22.5 cc/rev)
- Relief pressure: 475 +/- 30 psi (32.75 bar)
- Flow: 15.4 gpm (58.3 lpm) @2600 rpm

Drive Motors

- Model: Rexroth MCR 5
- Displacement: 50 in³/rev (820 cc/rev)

Pilot Controls (Joysticks)

- Model: Rexroth 08-351

Auxiliary Pump

- Make: Rexroth
- Type: Axial Piston, Variable Load Sense
- Displacement: 2.75 in³/rev (45 cc/rev)
- Max Flow: 30 gpm (113.6 lpm) @ 2600 rpm
- Relief pressure: 3000 psi (20,680 kPa)
- Marginal (Standby) Pressure: 218 psi (1,503 kPa)
- Cooling/filtering: Oil is filtered and cooled at all times. In auxiliary mode, the oil is filtered after the attachment to protect the machine if the attachment motor fails or contaminants are introduced from the quick couplers.

Lift Arm Control Valve

- Make: Rexroth
- Type: Load Sense

Oil Cooler

- Operating pressure: 150 psi (1034 kPa)
- Bypass relief pressure: 80 psi (689 kPa)
- Hot oil sending unit: 225°F (107.2°C)
- Avg. oil operating temp. 50-60°F above ambient. (High flow application 80°F above ambient.)

Critical Torque Specs

- Transmission Mounting Bolts
 - 85 ft-lb. w/Blue Loctite
- Drive Sprocket Drive Teeth Bolts
 - 88 ft-lb. -Dry
- Bogie Wheel (10" Idler) Retaining Bolt
 - 180 ft-lb. - w/Red Loctite
- 15" Idler Wheel Retaining Nut
 - 350 ft-lb. -Dry
- Drive Sprocket Lug Nut
 - 206 ft-lb. -Dry
- Drive Motor Mounting Bolts
 - 206 ft-lbs. -Dry

Cycle Times

- Lift-Arm up: 3.5 seconds (+/- .35 seconds)
- Lift-Arm Down: 3.3 seconds (+/- .33 seconds)
- Bucket Curl: 1.7 seconds (+/- .17 seconds)
- Bucket Dump: 1.9 seconds (+/- .19 seconds)

Service Tools

Listed below are common service tools which are identified and utilized in the service procedures described in this manual. Use tools recommended by ASV whenever possible to reduce risk of injury and or machine damage during service.

- ASV Jack Stands (2) (ASV P/N: 0402-900)
- Heavy Duty Hydraulic Jack (5-ton rating)
- Test Gauge Kit (ASV P/N: 0402-935)
- Ratchet Strap
- Long Pry Bar(s)
- ASV Service Cart (0402-871)

SR-70 Specifications

Engine

- Model: Perkins 804C-33T
- Displacement: 3.3 liter
- Gross horsepower: 71 hp (53 kW)
- Torque: 173 lb-ft. (234 Nm)
- Idle rpm: 1000 (low idle), 2600 (high idle)
- Average water /thermostat temperature: 190°F, 87.8°C

Transmission

- Model: Cat A22VG45 tandem (Rexroth)

Drive Pumps

- Displacement: 2.7459 in³/rev (45 cc/rev)
- Relief pressure: 5500 psi (380 bar)
- Flow: 30.91 gpm (117 lpm) @ 2600 rpm (per pump)

Charge Pump

- Displacement: 1.373 in³/rev (22.5 cc/rev)
- Relief pressure: 475 +/- 30 psi (32.75 bar)
- Flow: 15.4 gpm (58.3 lpm) @2600 rpm

Drive Motors

- Model: Rexroth MCR 05 C
- Displacement: 37.8 in³/rev (620 cc/rev)

Pilot Controls (Joysticks)

- Model: Rexroth 08-351

Auxiliary Pump

- Make: Rexroth
- Type: Axial Piston, Variable Load Sense
- Displacement: 2.75 in³/rev (45 cc/rev)
- Max Flow: 30 gpm (113.6 lpm) @ 2600 rpm
- Relief pressure: 3000 psi (20,680 kPa)
- Marginal (Standby) Pressure: 218 psi (1,503 kPa)
- Cooling/filtering: Oil is filtered and cooled at all times. In auxiliary mode, the oil is filtered after the attachment to protect the machine if the attachment motor fails or contaminants are introduced from the quick couplers.

Lift Arm Control Valve

- Make: Rexroth
- Type: Load Sense

Oil Cooler

- Operating pressure: 150 psi (1034 kPa)
- Bypass relief pressure: 80 psi (689 kPa)
- Hot oil sending unit: 225°F (107.2°C)
- Avg. oil operating temp. 50-60°F above ambient. (High flow application 80°F above ambient.)

Critical Torque Specs

- Transmission Mounting Bolts
 - 85 ft-lb. w/Blue Loctite
- Drive Sprocket Drive Teeth Bolts
 - 88 ft-lb. -Dry
- 10" Idler Wheel Retaining Nut
 - 350 ft-lb. -Dry
- 15" Idler Wheel Retaining Nut
 - 350 ft-lb. -Dry
- Drive Sprocket Lug Nut
 - 129 ft-lb. -Dry
- Drive Motor Mounting Bolts
 - 129 ft-lbs. -Dry

Cycle Times

- Lift-Arm up: 3.5 seconds (+/- .35 seconds)
- Lift-Arm Down: 3.3 seconds (+/- .33 seconds)
- Bucket Curl: 1.7 seconds (+/- .17 seconds)
- Bucket Dump: 1.9 seconds (+/- .19 seconds)

Service Tools

Listed below are common service tools which are identified and utilized in the service procedures described in this manual. Use tools recommended by ASV whenever possible to reduce risk of injury and or machine damage during service.

- ASV Jack Stands (2) (ASV P/N: 0402-900)
- Heavy Duty Hydraulic Jack (5-ton rating)
- Test Gauge Kit (ASV P/N: 0402-935)
- Ratchet Strap
- Long Pry Bar(s)
- ASV Service Cart (0402-871)

3. Circuit Diagrams

Chapter Overview

This chapter contains diagrams for the following SR-70/80 circuits: hydraulic charge circuit, hydraulic auxiliary circuit, hydraulic drive circuit, loader valve, hydraulic pilot generation (solenoid) block and electrical attachment outlet. It also contains hose routing information for the control configurations for the drive and lift arm pilot controls.

Hydraulic Charge Circuit

Figure 3-1 SR-70/80 Hydraulic Charge Circuit

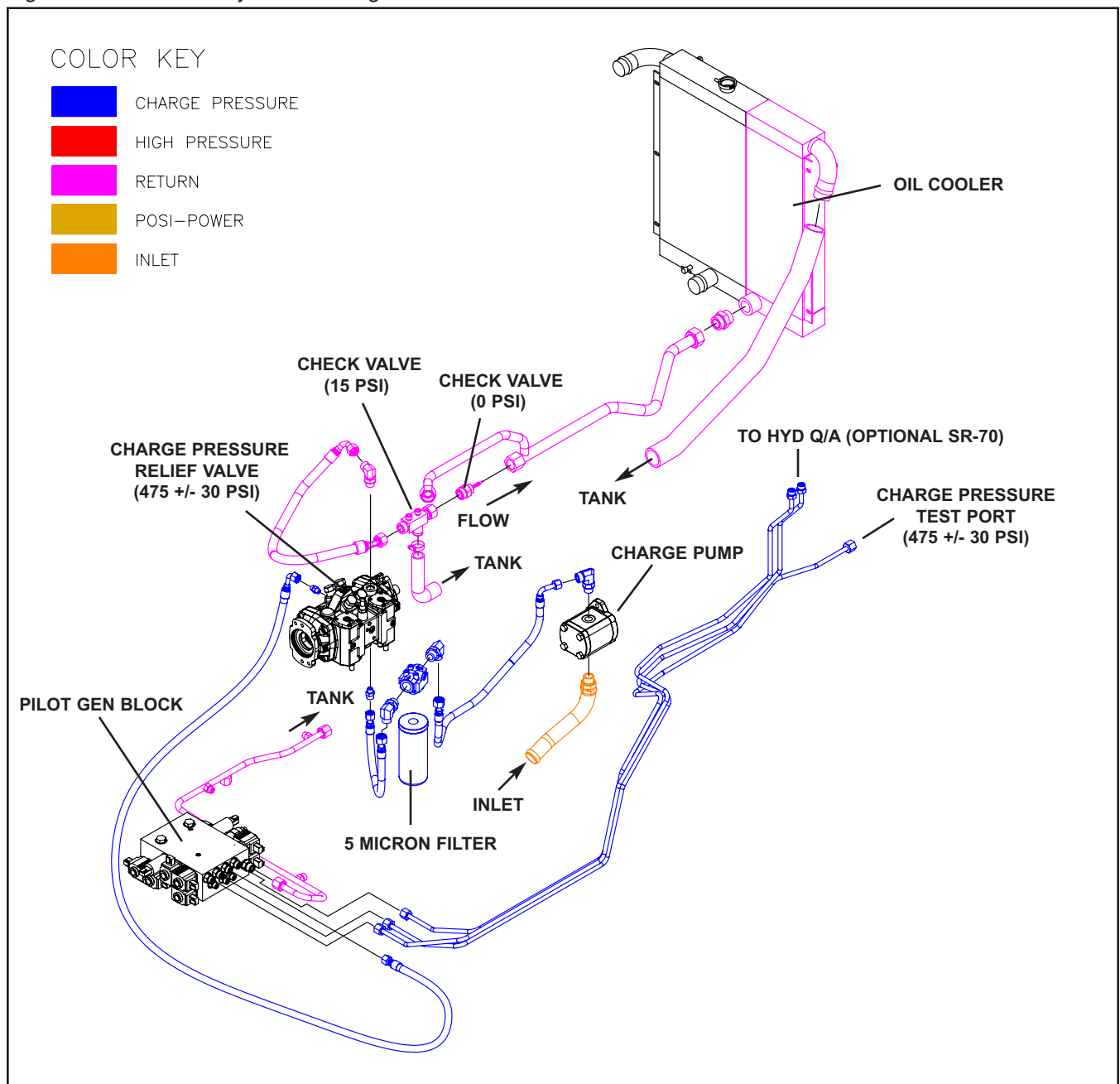

Hydraulic Auxiliary Circuit

Figure 3-2 SR-70/80 Hydraulic Auxiliary Circuit

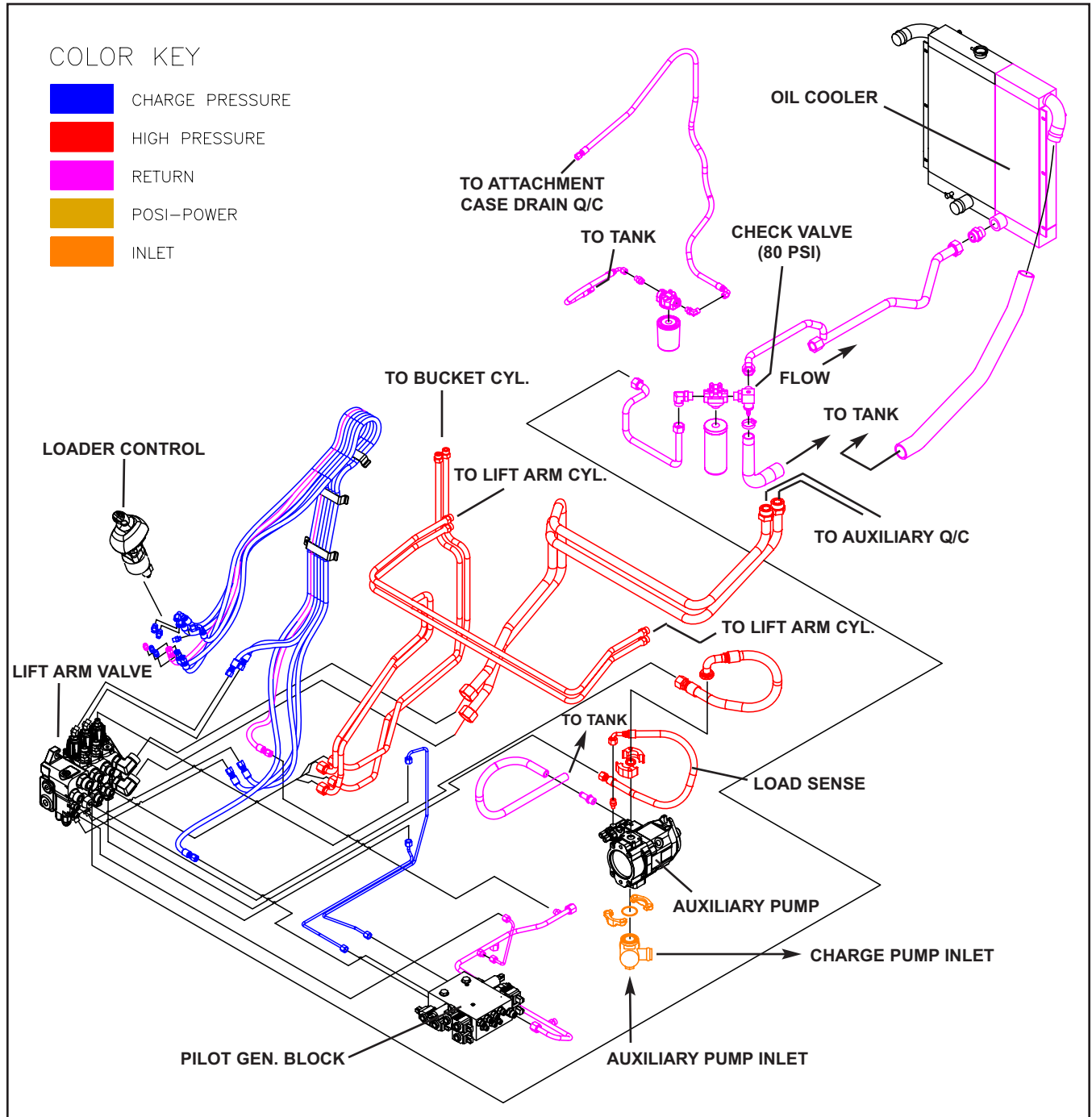

Hydraulic Drive Circuit

Figure 3-3 SR-70/80 Hydraulic Drive Circuit

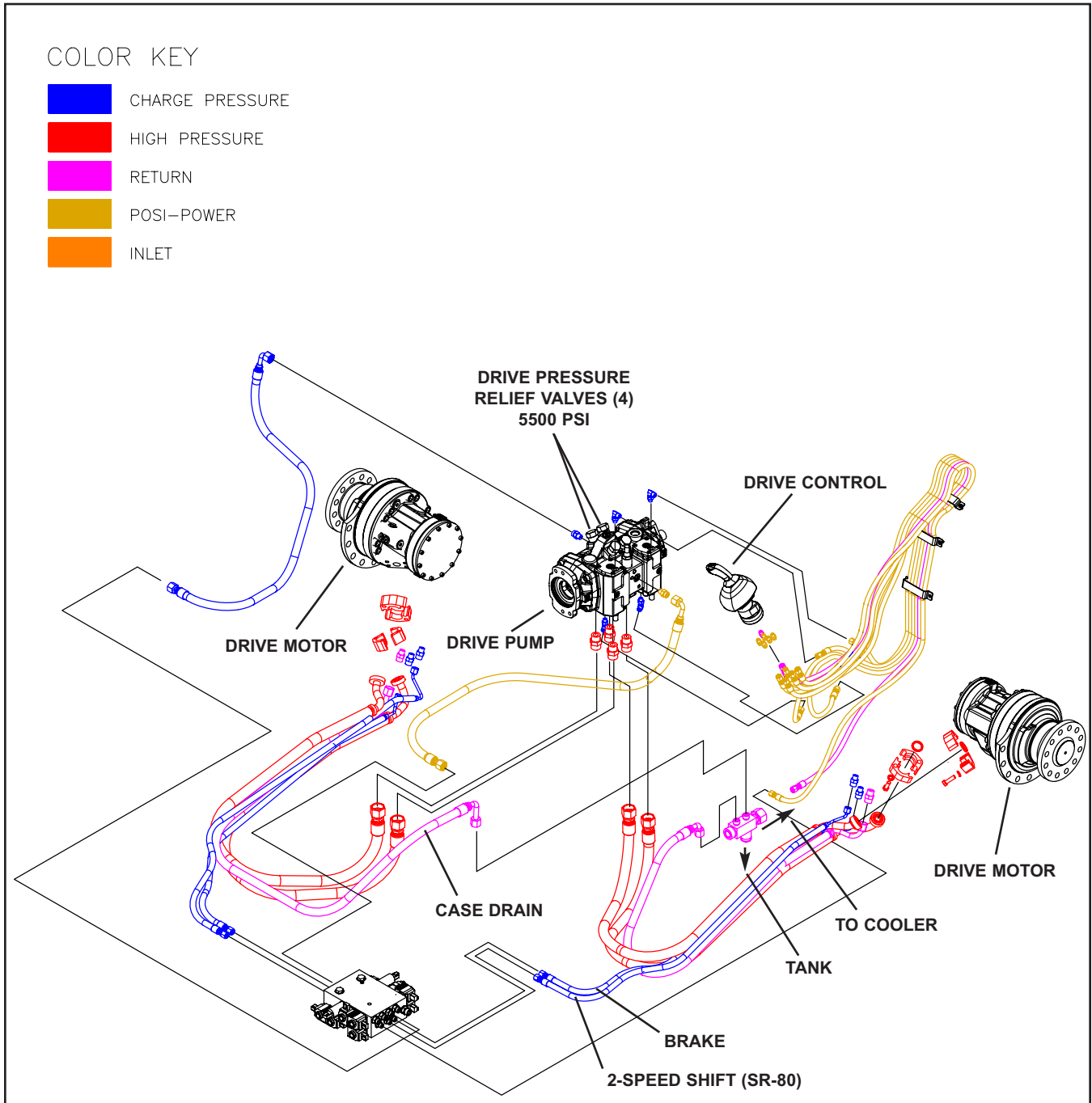

Lift Arm Control Valve

Figure 3-4 SR-70/80 Lift Arm Control Valve

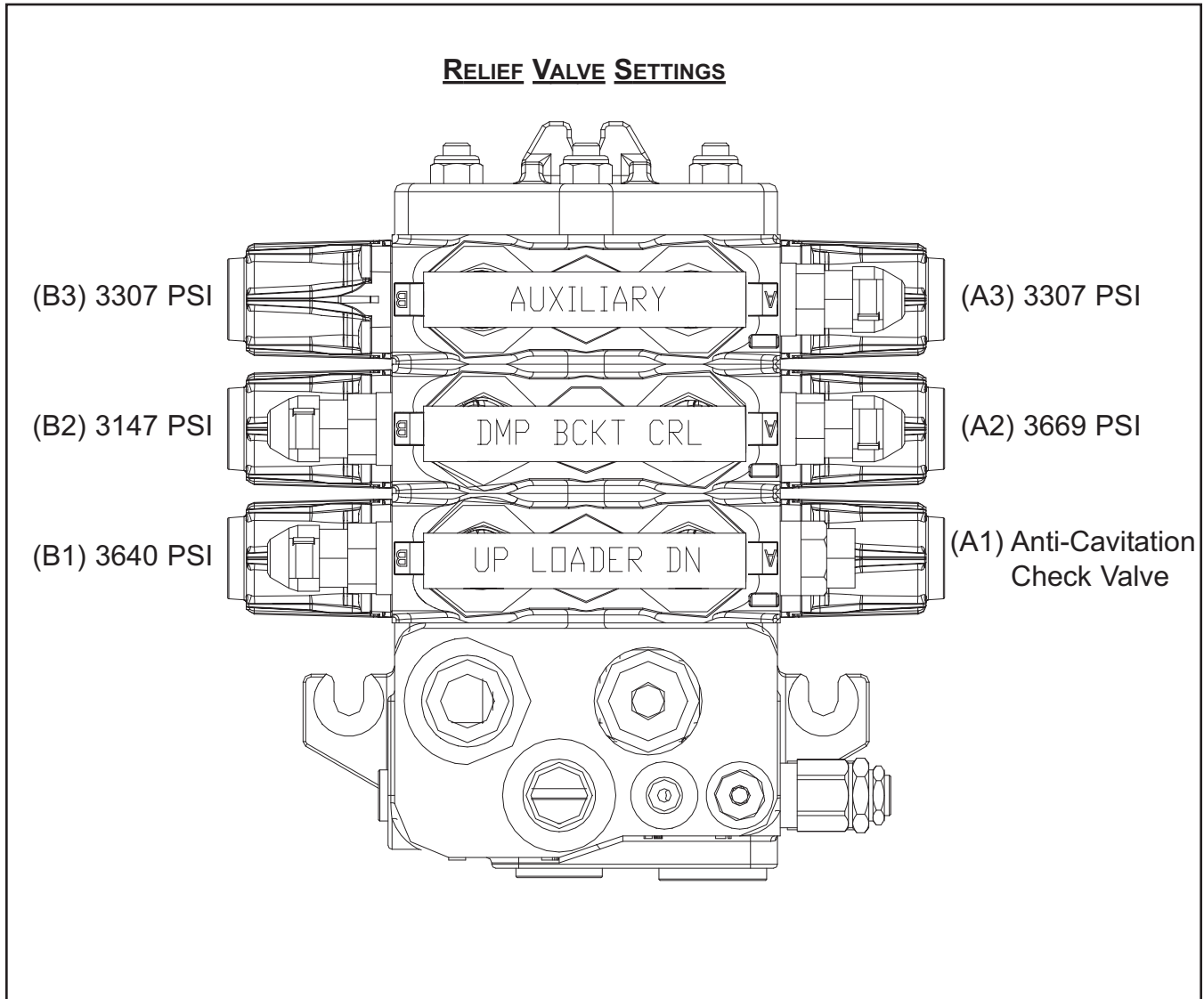

Hydraulic Pilot Generation Block

Figure 3-5 SR-70/80 Hyd. Pilot Generation Block

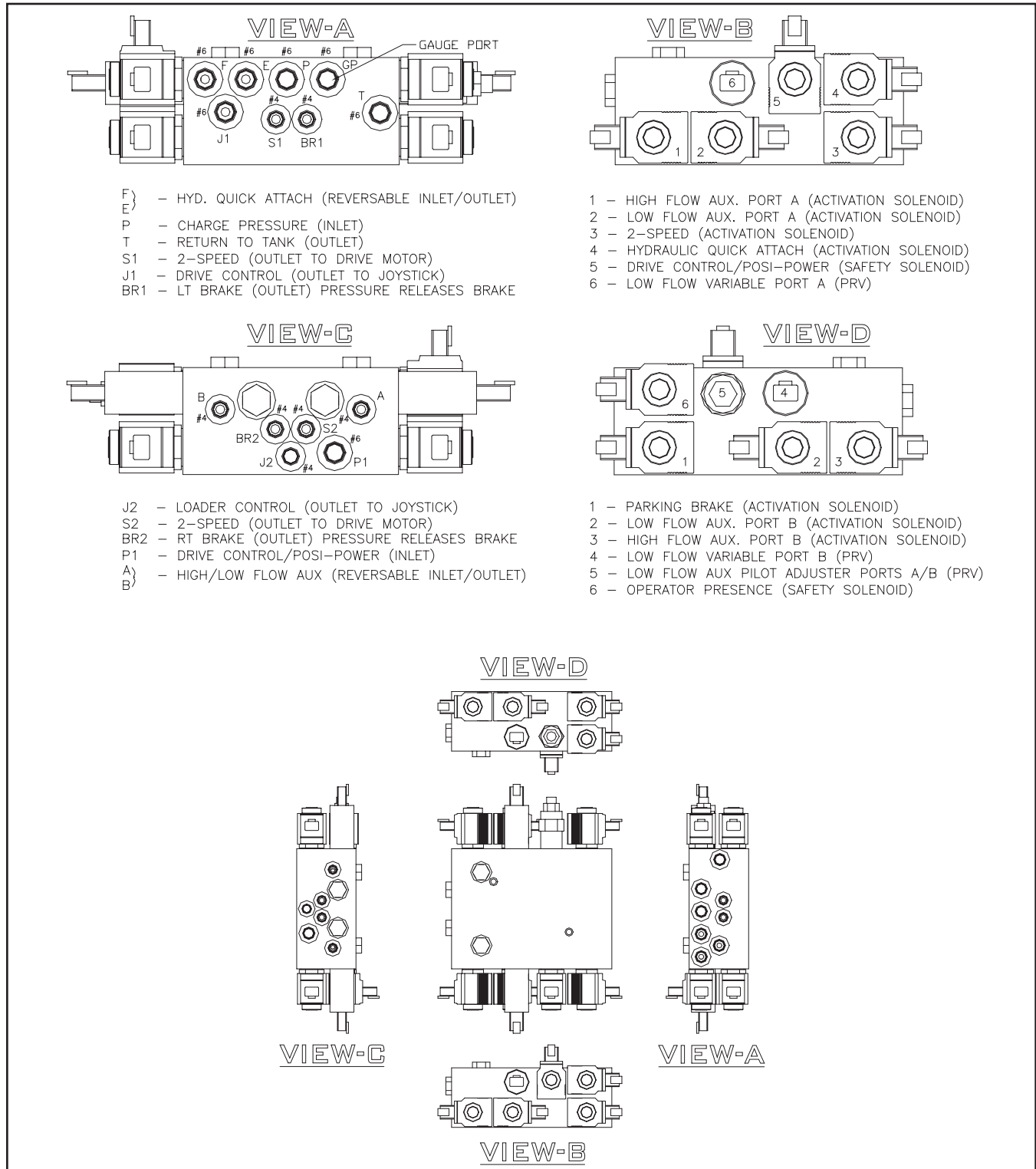

Electrical Attachment Outlet

Figure 3-6 SR-70/80 Electrical Attachment Outlet

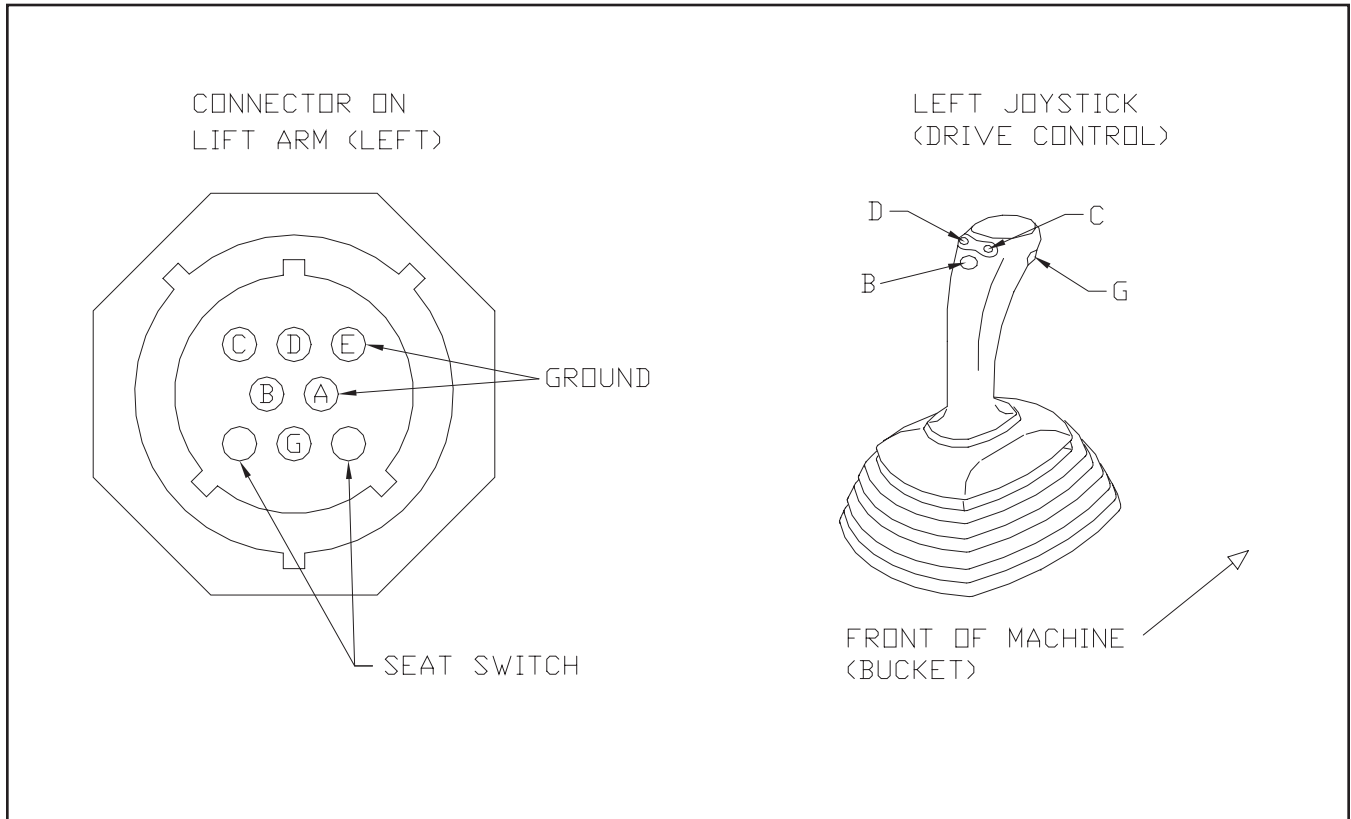

Lift Arm Control (line routing)

Figure 3-8 SR-70/80 Lift Arm Control

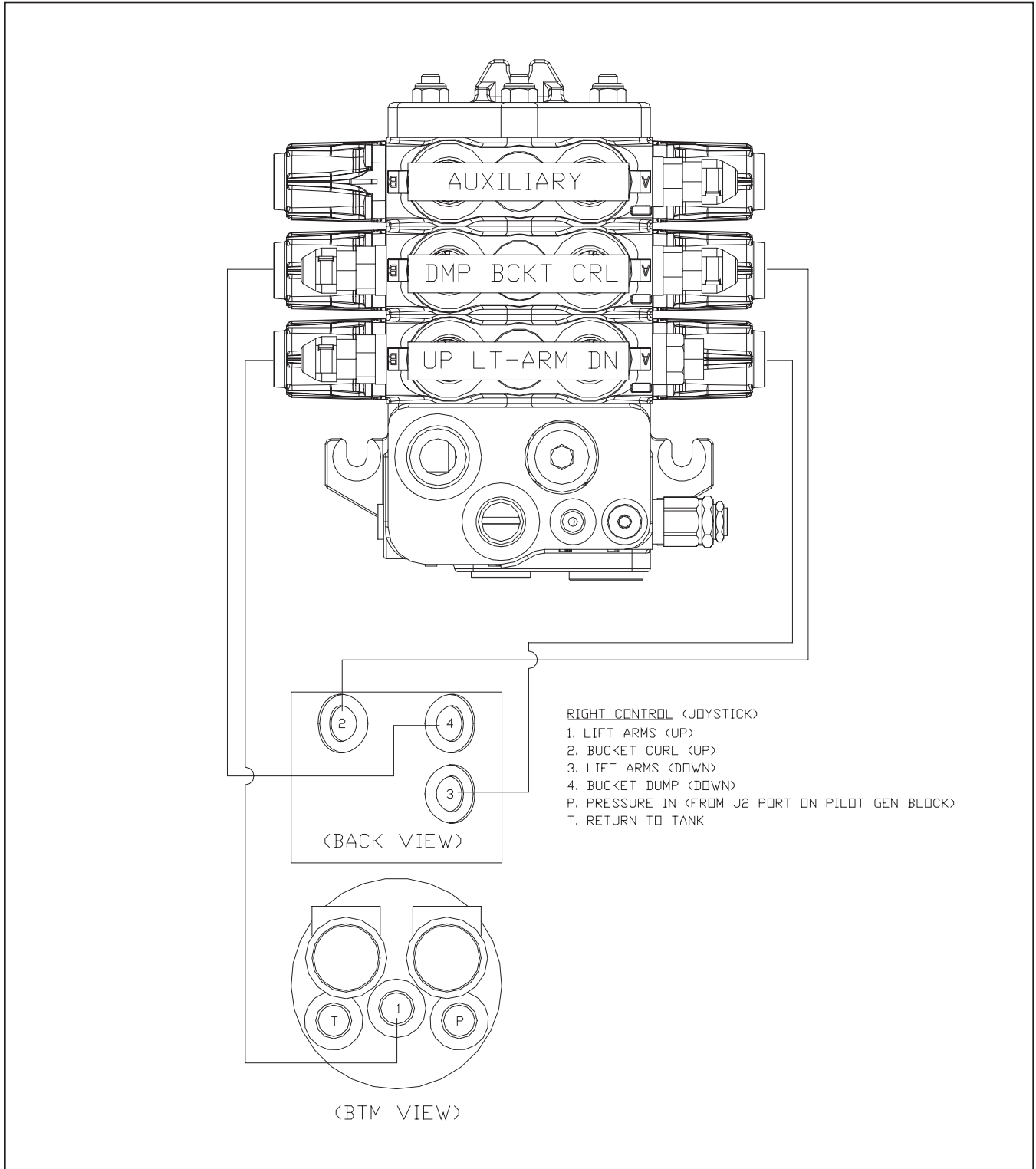

4. Maintenance

Chapter Overview

This chapter provides information on general maintenance procedures for the SR-70/80. If there is an issue that requires troubleshooting, refer to Chapter 18, Troubleshooting.

Personal Safety

!WARNING!

Improper or incomplete maintenance/repair of a Rubber Track Loader can be dangerous and may result in machine damage, injury or even death.

Do not attempt to perform any type of repair or maintenance on a Rubber Track Loader until you have read and fully understood the information in this manual.

Refer to the Operation and Maintenance manual for instructions regarding proper machine operation techniques before operating any Rubber Track Loader.

Prior to performing any type of service work on a Rubber Track Loader, read and understand Chapter 1 (Product Safety) for personal safety information.

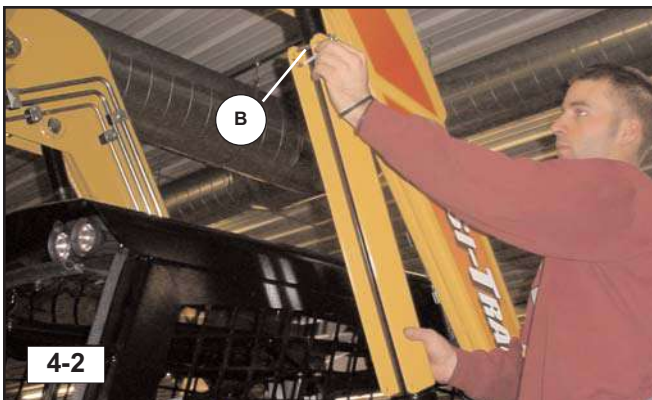

Lift Arm Brace

The lift arm brace (A) is intended to keep service personnel safe when it is necessary to work on a machine with the lift arms in the raised position. It is not safe to rely on the hydraulic system to hold the lift arms in the raised position just as it is not safe to crawl under a machine supported only by a jack. The lift arm brace is used to support the weight of the lift arms much like jack stands are used to mechanically support vehicle weight.

To install the lift arm brace:

1. Park the machine on level ground in a safe area for performing service work.
2. Remove any attachments that may be fastened to the quick attach.
3. Have an assistant remove the retaining pins (B) securing the lift arm brace and remove it from the machine.
4. Make sure bystanders are clear of the lift arms, then raise them to the upper limit.
5. Have an assistant install the brace around the cylinder shaft as shown and reinstall the pins to secure it to the cylinder.
6. Lower the lift arms slowly until they come to rest on the brace.
7. It is now safe to shut the engine off and exit the machine.

!WARNING!

Do not work on or near the machine with the lift arms in the raised position unless the lift arm brace has been correctly installed.

To remove the lift arm brace:

1. Start the machine and raise the lift arms until they are clear of the brace.
2. Once clear, have an assistant remove the brace from the cylinder and stow it on the machine with the pins.
3. Once the brace has been stowed and the assistant is clear of the lift arms, lower the arms to the ground and shut the engine off to complete the procedure.

4. Maintenance

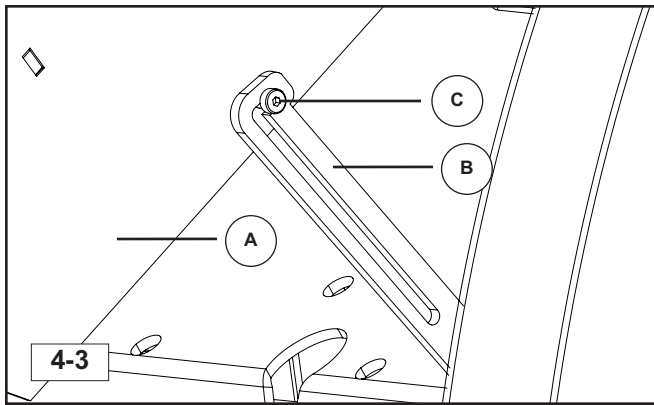

Tilt-Up Cab

The ROPS/FOPS approved cab (A) tilts up to allow easier access while performing maintenance. It features a gas spring assist and a brace mechanism to hold it in place while tilted.

To tilt the cab:

1. Remove any attachments that may be fastened to the machine.
2. (Optional) Raise the lift arms and secure them with the lift arm brace. (See page 4-1.)
3. Remove the two bolts that fasten the cab to the chassis. They are located inside the cab, one in each of the front corners.
4. Once the bolts have been removed, tilt the cab slowly upwards. The cab brace (B) should fall onto the shoulder bolt (C) locking the cab in its upright position.

The cab is now secure.

To lower the cab:

1. Raise the cab brace so that the locking channel is clear of the shoulder bolt.
2. Hold the brace upwards and lower the cab until the locking channel is clear of the shoulder bolt then release the brace.
3. The cab is now free to be lowered into operating position.
4. Lower the cab completely and then fasten it to the chassis with the two bolts removed previously.



Jacking Procedure

Occasionally, your machine may need to be suspended off of the ground to perform maintenance. Exercise caution when jacking the machine. Always use a jack that is capable of lifting the machine and support its weight with ASV approved jack stands while suspended. Never work on or under a machine supported only by a jack.

To safely jack your machine:

1. Remove any attachments that may be fastened to the machine and raise the lift arms.
2. Install the lift arm brace as instructed on page 4-1.
3. Once the lift arms are secured, carefully exit the machine.
4. Roll or slide your jack under the front of the machine and center the lifting pad directly under the middle of the front torsion axle.
5. Once in place, jack the machine upward making sure it remains stable until it has reached sufficient height to install an ASV jack stand beneath the machine. (fig. 4-4)
6. Slide the jack stand into place making sure it is centered under the machine (left to right when viewed from the front) and far enough back for the machine to remain stable when the jack is lowered and the front of the machine rests on the stand. (fig. 4-5)
7. Once the stand is in place, slowly lower the machine onto the stand and then remove the jack.

Repeat steps 4-7 at the rear of the machine should both ends of the machine need to be off of the ground for service.

Grease Fitting Locations

- A. Lower Bucket Cylinder Pivot (2)
- B. Upper Bucket Cylinder Pivot (2)
- C. Front Lift Cylinder Pivot (2)
- D. Lift Arm Pivot (2)
- E. Rear Lift Cylinder Pivot (2)
- F. Rear Axle Pivot (2)
- G. Front Axle Pivot (2)
- H. Lower Bucket Pivot (2)

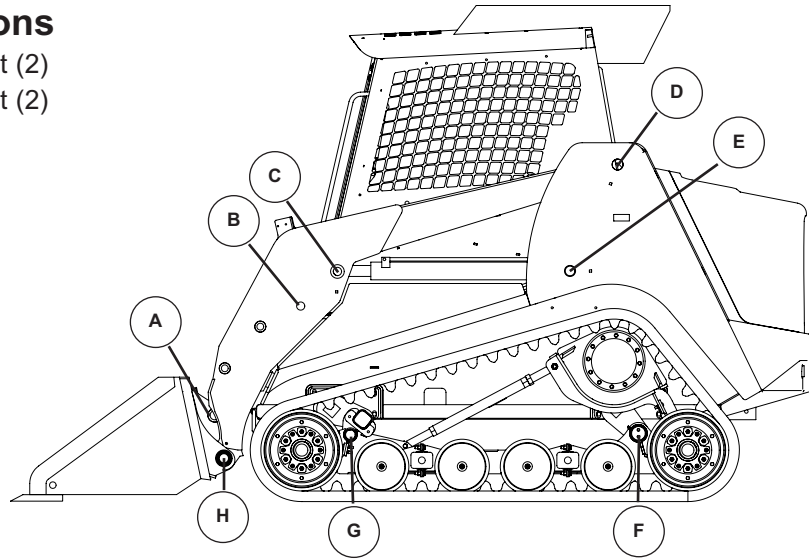

4-6

Grease Fittings

The SR 70/80 are equipped with grease fittings at pivot points throughout the machine. The illustration above shows the locations of all fittings on the left side of the machine. An identical fitting exists on the right side of the machine for each one identified in the illustration. Lubricate all fittings **DAILY** or after every 10 hours of operation to maximize component life and ensure proper machine function. (fig. 4-6)

Undercarriages

The undercarriage assemblies in Rubber Track Loaders typically operate in harsh working conditions. They work in mud, gravel, debris and various other abrasive materials during operation. ASV recommends a daily inspection of the undercarriage assemblies and cleaning if necessary.

Materials that are particularly sticky or abrasive like clay, mud, or gravel should be cleaned from the undercarriages more often to minimize component wear. A pressure washer works well for cleaning materials from the undercarriages. At times when a pressure washer is not available, use a bar, shovel or similar device to remove foreign materials.

When cleaning, pay particular attention to the drive tables, sprockets, and the front and rear wheels where debris is likely to accumulate. If working in scrap or debris, inspect more often and remove foreign objects that may wrap around or lodge themselves between components causing premature wear and damage.

Operation in loamy sand or on turf or other finished surfaces may require less frequent cleaning, but daily inspection is still advised.

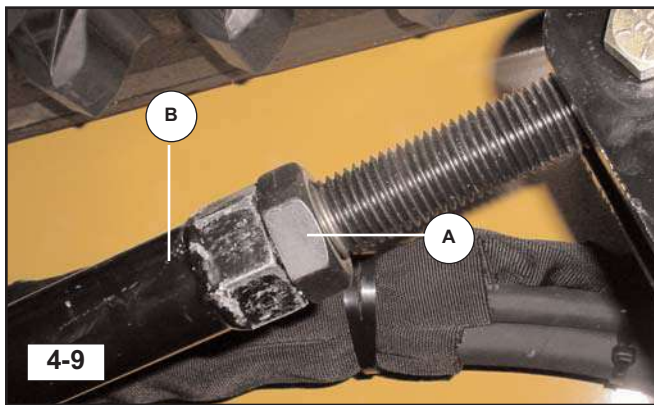
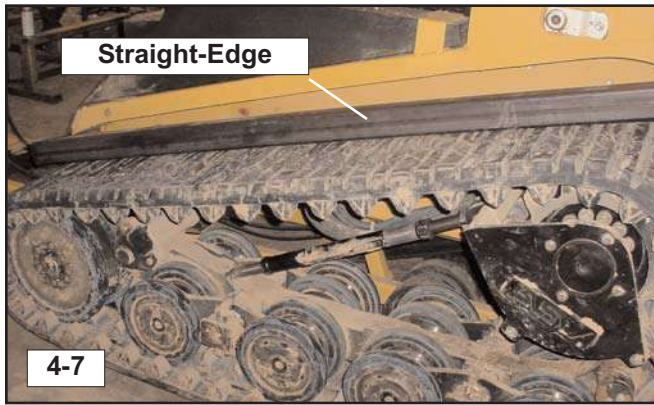

Track Tension (SR-70/80)

Proper track tension must be maintained for optimal performance and track/undercarriage life. Running a track that is too loose may cause the track to misfeed possibly causing damage to the track and or undercarriage components. Running a track that is too tight may cause track stretch, premature bearing failure, or other preventable damage to the machine. As a rule, a track should only be tightened to the point where there is no visible sag. Never tighten your tracks beyond this point.

Note: During the first 50 hours of operation the tracks will "break-in" and will most likely require adjustment.

To check track tension: (fig. 4-7, 4-8)

1. Drive the machine forward 5 feet to remove belt slack from the lower and rearward portions of the track.
2. Lay a straight edge along the top of the track bridging the drive sprocket and front idler wheel.
3. Apply 90 lbs. of down force to the track by either placing weight on top or hanging it using rope or wire midway between the drive sprocket and front idler.
4. Measure from the bottom of the straight edge to the lug surface (top) of the track. The deflection should measure between 3/4" and 1".

To adjust track tension: (fig. 4-9)

1. Loosen the lock nut (A) on the turnbuckle (B) and adjust by turning the turn buckle itself until proper tension has been achieved.
2. Then tighten the turnbuckle lock nut to complete the procedure.
3. Repeat the adjustment procedure on the other side of the machine if necessary.

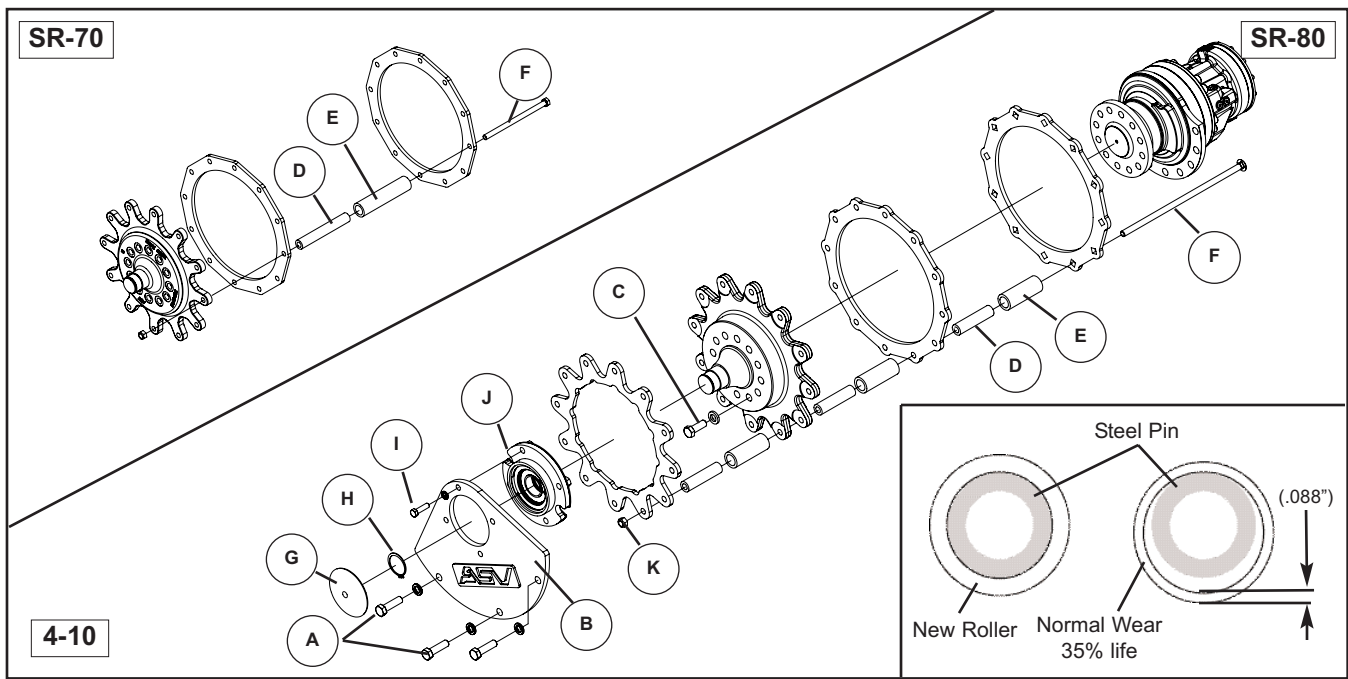

Drive Sprocket Rollers

ASV rubber track loaders utilize rollers on the drive sprockets to drive the track. These rollers help minimize friction between the track and the drive sprocket to prolong track life.

The rollers rotate around hardened steel pins and usually wear on their inside surfaces. As they wear, the rollers become thinner, but will continue to function as long as they rotate freely around the pins. Sprocket rollers should be inspected every 50 hours of operation and replaced if cracked or worn to less than 35% of original thickness. (.088")

To replace worn rollers:

1. Begin by performing steps 1-4 in the track removal procedure on page 4-6 to allow the sprocket to be removed.
2. Remove the seven bearing plate mounting bolts (A, I), then remove the plate (B) from the drive table.
3. Remove the bearing cap (G) by tapping around the bulged area of the cap with a hammer. This will relieve the outward pressure on the cap and allow for removal.
4. Remove the external snap ring (H) from the bearing shaft.
5. Using a puller, remove the bearing assembly (J) from the shaft.
6. Remove the sprocket mounting bolts (C), then remove the sprocket.

Note: You may need to pry or lift the track upwards with a hoist above the drive sprocket to provide clearance for removal.

7. Remove one bolt (F) holding the steel pins (D) and rollers (E) in place. Install the new rollers over the pins, then slide the bolt back through the sprocket and pins and secure it with the nut (K).
8. Repeat this process as required throughout the sprocket.
9. Reinstall the sprocket by reversing steps 2-6.

Note: During removal of the bearing cap (step 3) the bulged area of the cap is beaten inward. When reinstalling, orient the cap so that the domed area is facing outward. Then tap the center of the cap with a ball peen hammer or similar device to reset the cap. Do this gently. Too much inward force can damage (mushroom) the bearing shaft.

10. Repeat steps 1-9 on the other side of the machine if necessary.
11. Perform the track tension adjustment and check procedures on page 4-4.

Note: Replace rollers as a set to simplify inspection and maintain proper sprocket function.

4. Maintenance

Track Removal/Installation

Tracks may need to be removed periodically to inspect undercarriage components or for replacement if worn or damaged. This section covers the procedure to remove and install a track on SR 70/80 machines.

Tools required:

- Socket/impact wrench
- Ratchet strap
- Heavy duty hydraulic jack
- Combination wrench
- Long pry bar(s)
- ASV approved jack stands (2)
- Spray lubricant
- Shop vac or Pressure washer

Note: The SR-80 style undercarriage is depicted in this procedure. The SR-70 undercarriage is very similar, however it has only one row of stationary inner and outer idler wheels. The track removal procedure is identical with this exception. (fig. 4-11)

Track Removal

1. Break up and remove any foreign material from the cavity between the suspension rail and the drive table support. (fig. 4-12)

Note: A shop vac or pressure washer will work well to remove material from this cavity.

2. Clean the threads on the turnbuckle thoroughly using a stiff bristle brush.
3. Loosen the lock nut on the turnbuckle and spin it to the end of the threaded shaft to allow clearance when the drive table is lowered. (fig. 4-13)
4. Rotate the turnbuckle and lower the drive table as far as it will go. (fig. 4-14)
5. Remove the bolts securing the outer front wheel to the hub. Then remove the wheel. (fig. 4-11, 4-15, 4-16)

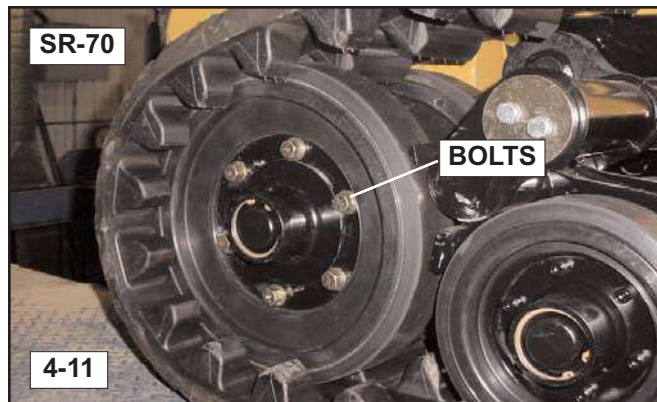
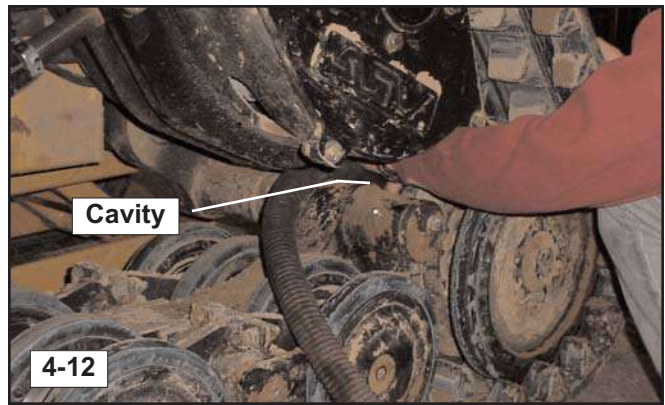



6. Remove the outer scraper plate from the suspension rail. (SR-80 only/fig. 4-17)
7. Remove the bolts securing the inner wheel to the hub, then remove the wheel. (SR-80 only/fig. 4-18, 4-19)
8. Use a pry bar to peel the track over the inner wheel(s) toward the outside of the machine. (fig. 4-20)
9. Once the track is off of the front wheel(s), pull the rear of the track clear of the suspension. (fig. 4-21, 4-22)

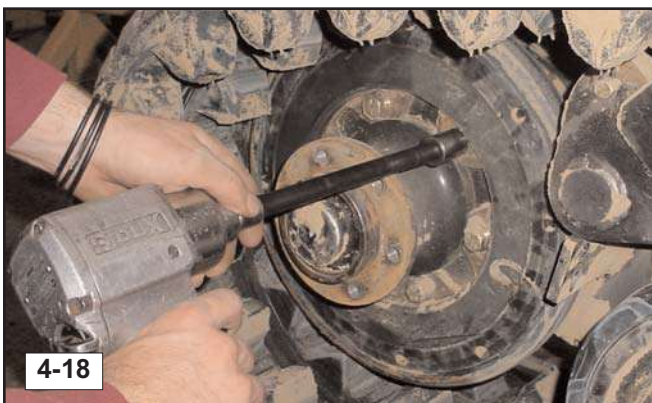

4. Maintenance

Track Installation

1. Slide the track over the drive sprocket at the rear of the machine. (fig. 4-23, 4-24)
2. Slide the front of the track into position for installation. (fig. 4-25)
3. Lubricate the inner front wheel(s) and the inside of the front portion of the track with a spray lubricant. (fig. 4-26)
4. Attach a ratchet strap to the upper front portion of the track and the other end to one of the tow hooks on the front of the machine. (fig. 4-27)
5. Tighten the strap until the track is pulled upward slightly and in position to slide over the inner idler wheel(s) at the front. (fig. 4-27)
6. Pull all of the slack forward and make sure the track drive lugs are properly meshed with the sprocket to provide as much slack as possible for installation.
7. If you have an assistant, have them pull the track forward while you push inward on the track. Work the track over the wheel(s) and into place.
8. If you do not have an assistant, push the track forward in inward in a quick forceful motion to slide the track into place. The ratchet strap will help to keep the track in place while you work it over the idler(s). (fig. 4-28)

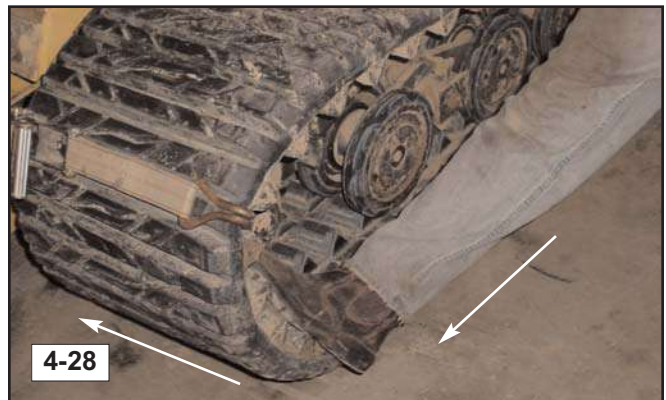
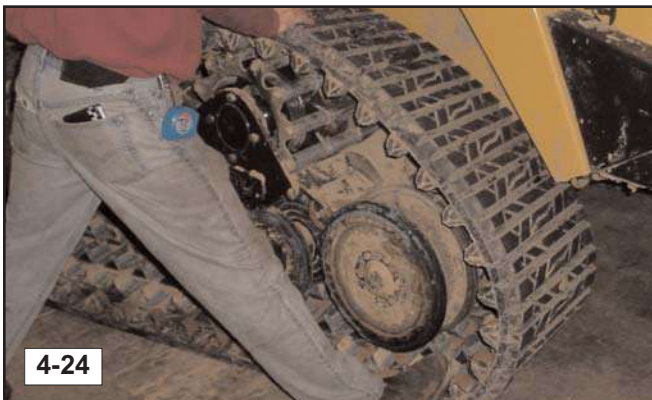

9. Once the track is in position over the idler wheels, install the inner idler wheel onto the hub and secure it in place with the mounting bolts. Torque them to 90 +/- 10 Lb. Ft. (SR-80 only/fig. 4-29, 4-30, 4-31)

Note: You may need to use a bar to keep the wheel from spinning as you torque the mounting bolts to spec. (fig. 4-31)

10. Install the scraper onto the suspension rail and tighten the bolts to secure it in place. (SR-80 only/fig. 4-32)
11. Install the outer idler wheel and secure it in place with the mounting bolts. Torque them to 90 +/- 10 Lb. Ft. (fig. 4-33, 4-34)
12. Perform the track tension adjustment and check procedures on page 4-4 to complete installation.



4. Maintenance

Air Cleaner

The SR 70/80 are equipped with two air filter elements to remove contaminants from the air used for combustion. Regular inspection and replacement is necessary to ensure proper performance and to prolong engine life.

To remove and inspect your air cleaner elements:

1. Turn the engine off.
2. Open the hood at the rear of the machine to gain access to the engine compartment.
3. Locate the black air cleaner enclosure near the top left of the engine compartment (when viewed from the rear).
4. Twist the tension screw (A) counter-clockwise until the band is loose enough to remove the cover, then remove the cover. The primary element (B) should be exposed.
5. Remove the primary element and inspect it. If it appears damaged in any way, replace it. If the element is heavily soiled, replace it. If it appears to be in good condition, clean if necessary and re-install.
6. Once the primary element has been removed, the secondary element (C) should be visible. Remove and inspect it. If the element is damaged or heavily soiled, replace it.

Note: The secondary element is not serviceable. It should be replaced after every three cleanings of the primary filter.

Note: The primary element may be cleaned and reused up to five times if properly maintained, but should be replaced at least once a year.

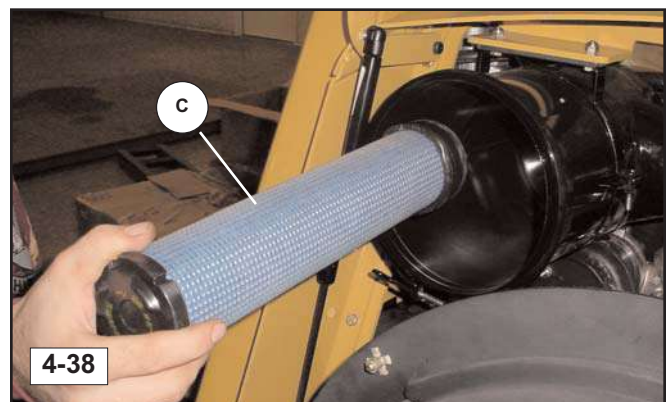
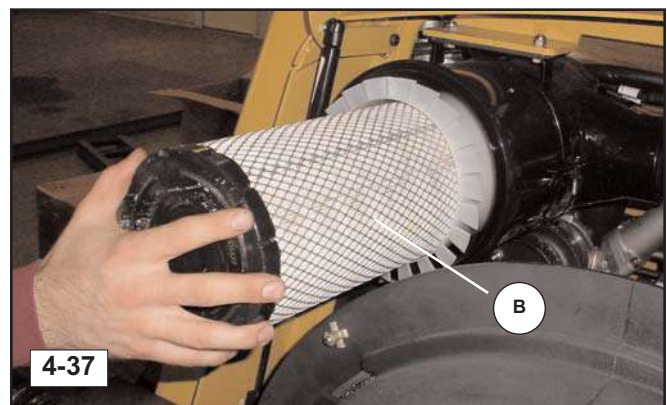
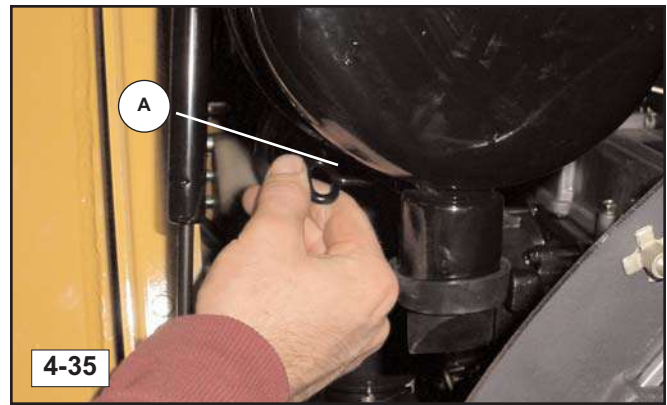



4-39

7. Once the inspection has been performed, install the new secondary filter element into the enclosure as found upon disassembly. (fig. 4-39)
8. Install the primary element by sliding it into place in the enclosure as found upon disassembly.
9. Install and secure the cover by sliding it into place and positioning the band over the retaining lip. Then turn the tension screw clockwise until tight. Gently wiggle the cover to make sure it is secure.

To clean your primary filter element:

1. Remove loose dirt from the filter element with compressed air or water hose.
Compressed air: 100 P.S.I. max. 1/8" diameter nozzle at least 2" away from filter.
Water: 40 P.S.I. max. without nozzle.
2. Soak the filter in a non-sudsing detergent solution for at least 15 minutes moving it gently through the solution to further clean the element. (Never soak for more than 24 hours.)
3. Rinse the filter thoroughly with a gentle stream of water to remove all dirt and remaining detergent.
4. Allow the filter to dry completely before re-installing it into the machine.

NOTICE

Do not use any heat source other than warm air at less than 160°F to dry the filter.

Do not clean air filter elements while engine warranty is in effect. During the warranty period, ASV recommends replacing air filter elements instead of cleaning them. Heavy-duty air filter manufacturers will not warrant the air filter once it has been cleaned.

Fuel Filter

The fuel filter removes contaminants from the fuel as it enters the engine for combustion. Over time the filter can become plugged and cause the engine to lose power, run roughly or fail to start. The fuel filter should be changed every 500 hours or more often if needed to prevent these conditions from occurring.

To change the fuel filter:

1. Clean the outside of the filter assembly thoroughly to reduce the chances of contaminants being introduced into the fuel system.
2. Twist the water separator catch bowl (A) counter clockwise (when viewed from the bottom) and remove it from the assembly. Take care not to lose the o-ring that seals it to the filter base.
3. Twist the upper lock ring (B) counter clockwise (when viewed from the bottom) and remove it from the assembly.
4. Slide the filter (C) downward to remove it. Note the position of the raised tabs on the upper portion of the filter to simplify reassembly.
5. Install the new filter element into the assembly by reversing steps 2-4.

Water Separator

The water separator removes water from the fuel supply as the engine runs. Drain the water separator daily to maintain proper function.

To drain the water separator:

1. Loosen the black screw on the bottom of the separator.
2. Re-tighten the screw after the water has been drained from the catch bowl.

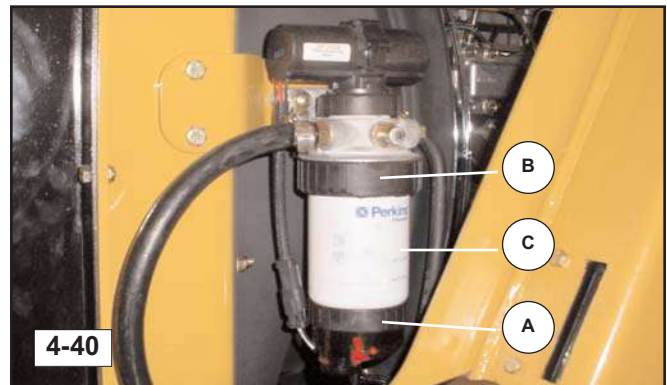

4-40

Accessory Belt Tension

Drive belts typically stretch and wear during their service life. The fan and A/C belts should be checked for tension, condition and presence daily prior to operating your machine.

To check fan or A/C belt tension:

1. With the engine cold and off, remove the key from the ignition to avoid accidental start.
2. Lift the hood at the rear of the machine and check to make sure the fan and A/C belts are present and in good condition. If they appear excessively worn, or cracked, replace them.
3. Lay a straight edge across the alternator and crank pulleys (crank and A/C pulleys for A/C belt) and apply a force of 10 lbs. midway between the pulleys. (fig. 4-41, 4-42)
4. Measure the distance from the bottom of the straight edge to the top surface of each belt (deflection). Fan belt deflection should measure 3/8" (7/16" A/C) if properly tensioned.
5. If the belts are loose or tight, adjust tension until correct.

To adjust fan or A/C belt tension:

1. Make sure the engine is cold, off, and the key has been removed from the ignition to avoid accidental start.
2. Lift the hood at the rear of the machine and loosen the bolts securing the alternator or A/C pump slightly to allow the alternator or A/C pump to pivot. (fig. 4-43, 4-44)
3. Once loose, use a small pry bar as a lever to force the alternator or A/C pump against the belt(s) to increase belt tension to appropriate level then tighten bolts to specification. (fig. 4-43, 4-44)
4. Check the belt tension.
5. Adjust belt tension as necessary until correct.

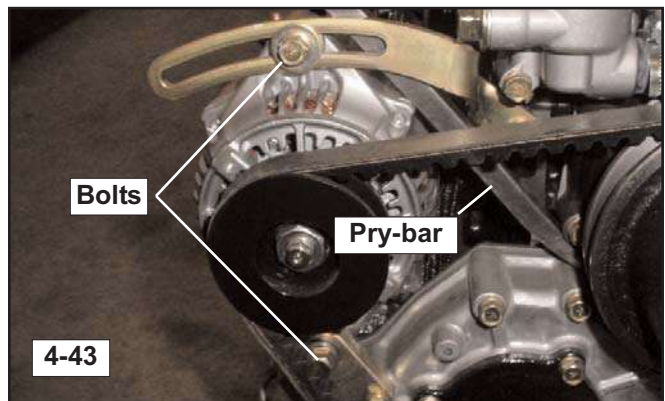
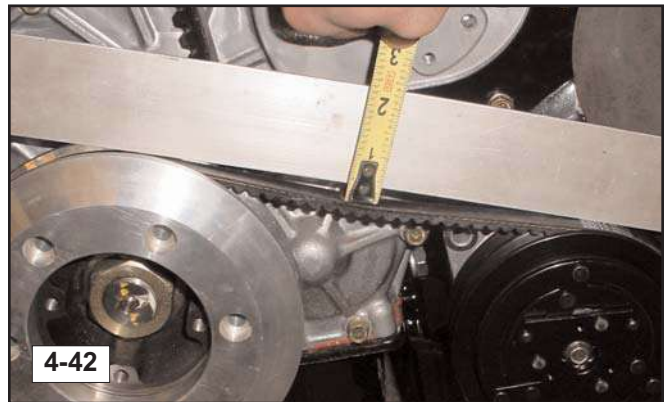
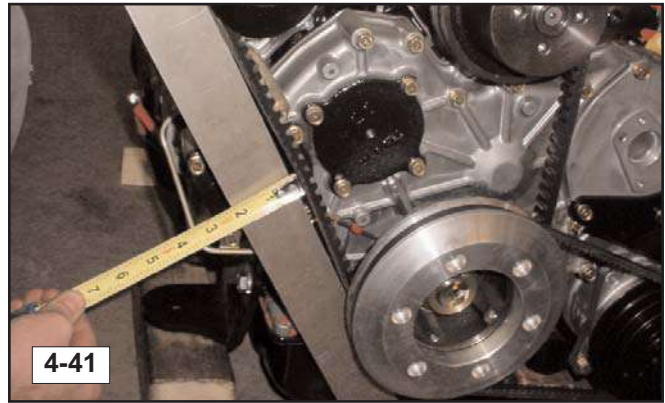

Fan Belt Removal & Installation

To remove the fan belt:

1. Follow steps 1 and 2 of the belt adjustment procedure.
2. Once loose, pivot the alternator towards the engine to increase slack.
3. Then, remove the three bolts securing the fan cage (half) to the fan shroud. Remove that portion of the cage. (fig. 4-45, 4-46)
4. Slip the belt off of the engine pulleys and work it around the fan until it is clear of the blades.

To install the fan belt:

1. Reverse the steps of the removal procedure.
2. Perform the belt tension check and adjustment procedures on page 4-12 to complete the installation.

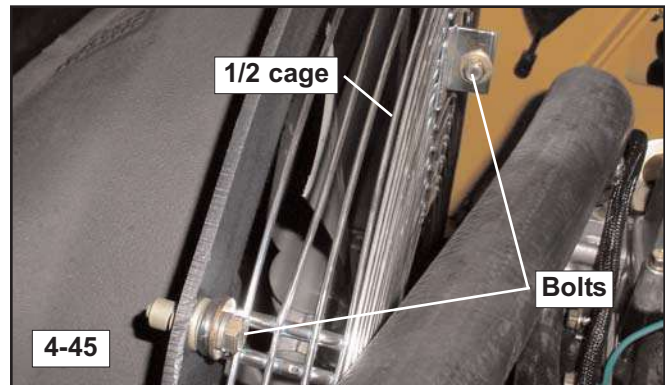
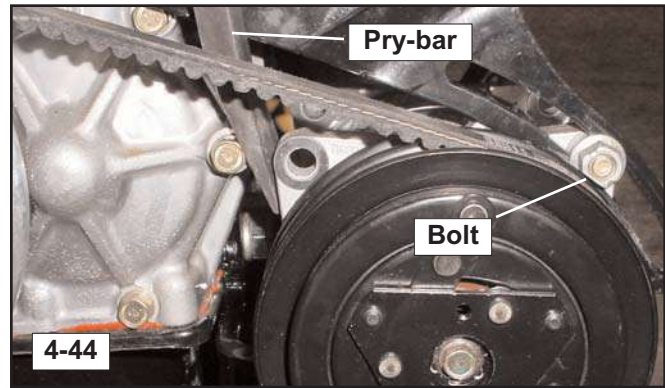

A/C Belt Removal & Installation

To remove the A/C belt:

1. Follow steps 1 and 2 of the belt adjustment procedure.
2. Once loose, pivot the A/C pump towards the engine to increase slack.
3. Slip the belt off of the pulleys and remove it from the machine.

To install the A/C belt:

1. Reverse the steps of the removal procedure to reinstall the belt.
2. Perform the belt tension check and adjustment procedures on page 4-12 to complete the installation.

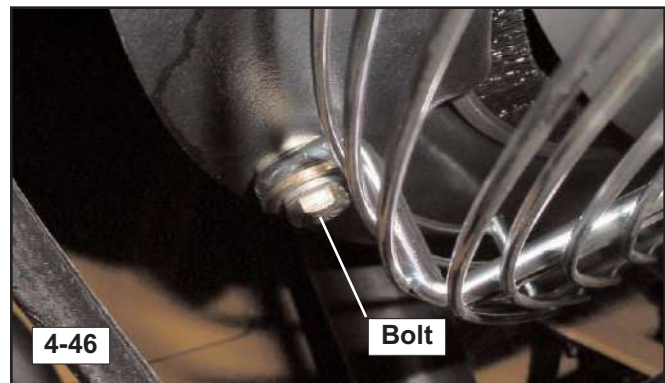

4. Maintenance

Engine Oil/Filter Change

Regular oil changes are necessary to maintain a strong running engine. The normal interval between oil changes is 500 hours or one year. Machines that are operated under harsh conditions should have their oil changed more frequently. ASV recommends oil change intervals of 250 hours or every six months for these machines. Harsh conditions may include: continuous high load applications, operation in high temperatures or abnormally dusty/dirty conditions.

To change the oil and filter:

1. Start and run the engine for a few minutes to warm the oil. Then turn the engine off before proceeding.
2. Place a suitable container under the engine oil drain plug to catch the used oil as it drains.
3. Remove the belly pan beneath the engine. (fig. 4-47)
4. Then remove the drain plug from the oil pan and allow the used oil to drain completely from the engine. Make sure to use the correct size combination/socket wrench to keep the drain plug in reusable condition. (fig. 4-48)
5. Remove the engine oil filter by hand or with strap if necessary. (fig. 4-49)
6. Once the filter has been removed, check to make sure the rubber gasket has come off of the filter head with the old filter. If it is not on the old filter, check the filter head. If it is still on the filter head, remove it prior to installing the new filter. (fig. 4-50)

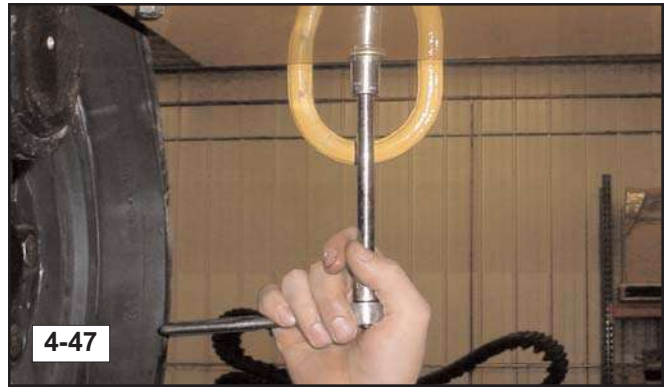

NOTICE

If the old filter gasket (A) is not removed from the filter head and the new filter is installed on top of it, an oil leak will result when the engine is started. If unnoticed, the engine can run itself out of oil causing engine failure.

7. Prepare new filter for installation by rubbing fresh oil on the exposed surface of the filter gasket.
8. Thread the new filter onto the filter head. Tighten the filter by hand as instructed by the label located on the filter or filter box.
9. Re-install the oil drain plug into the pan and tighten to 50 +/- 10 lb ft.





4-51

10. Remove the oil filler cap and fill the engine crankcase with ASV Posi-Lube™ 10W-30 Heavy Duty Engine Oil (capacity: 9 U.S. quarts including filter). (fig. 4-51)
11. Install the oil filler cap.
12. Perform a visual inspection to make sure the drain plug, filter and oil filler cap are in place and tight.
13. Start the engine and watch the oil pressure gauge located in the lap bar instrument display. The needle should rise up into the green range as soon as oil pressure has been established. If the needle doesn't rise above the red zone shortly after start-up, turn the engine off immediately and look for potential problems. If the needle does move into the green zone as expected, oil pressure has been achieved.
14. Once the engine is running, perform a visual inspection to make sure there are no leaks or other visible problems.
15. If everything looks like it should, shut the engine down and exit the machine.
16. Re-install the belly pan.
17. Perform the oil level check procedure.

Engine Oil Specifications

ASV recommends using Posi-Lube™ 10W-30 Heavy Duty Engine Oil for most conditions. In the event of an alternate working environment, the following chart may be used as a guide to oil viscosity grades.

You may also use a quality engine oil substitute meeting the following minimum specification:

- API CH-4 multigrade engine oil.

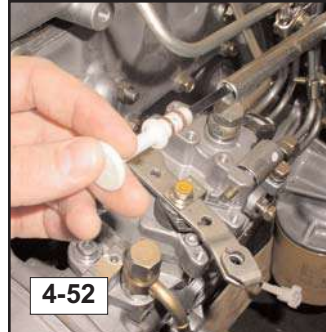
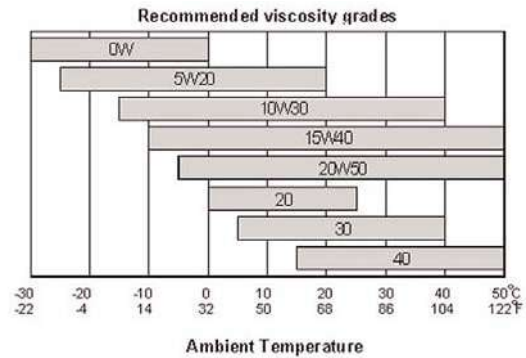

4-52

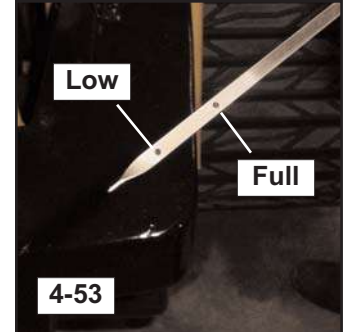

4-53

Oil Level Check

To check the oil level:

1. Park the machine on level ground.
2. Open the hood to gain access to the engine compartment.
3. Locate and remove the engine oil dipstick from its tube. (fig. 4-52)
4. Wipe the dipstick with a clean shop cloth and re-insert it into the tube until it comes to rest in its seated position.
5. Remove the dipstick once again and inspect the end for oil on the level indicator. (fig. 4-53)
6. Oil should be present on the dipstick up to, but not over the upper (full) level indicator notch. If the level is correct, reinstall the dipstick and then close and latch the hood to complete the procedure.
7. If the level is low, add the proper grade and viscosity engine oil and re-check as necessary until the proper level has been achieved. Then re-install the dipstick and filler cap and close and latch the hood to complete the procedure.

4. Maintenance

Hydraulic Fluid/Filter Change

Hydrostatic components require extremely clean oil in order to have a long service life. Use extreme caution when changing the hydraulic oil. Introducing dirt or debris could be detrimental to the hydraulic system. ASV recommends service intervals of 500 hours for hydraulic fluid and 250 hours for hydraulic fluid filters.

To change the hydraulic fluid:

1. Locate the hydraulic system drain access situated in the belly pan between the axles on the right side of the machine. (fig. 4-54)
2. Remove the drain plug using the correct size allen type wrench or allen socket to avoid damaging the drain plug. (fig. 4-54, 4-55)
3. Drain the hydraulic fluid into a suitable catch container.
4. Locate the two hydraulic filters underneath the cab on the left side of the machine. (fig. 4-56)
5. Thoroughly clean around the filters to prevent dirt or debris from entering the system and remove the filters by hand or with a strap as required.
6. Check to make sure the filter gaskets are still present on the old filters. If not, check the filter heads to make sure they are free from old gasket material prior to installing the new filters.
7. Prepare the new filters by rubbing a small amount of fresh hydraulic oil onto the filter gasket surface and then threading them onto their respective filter heads. Tighten filters by hand as instructed by the label located on the filter or filter box.
8. Install the hydraulic system drain plug and tighten.
9. Remove the hydraulic reservoir filler cap (black) and fill the hydraulic system with ASV Posi-Lube Premium All Season MV Hydraulic Oil or equivalent until the full mark on the hydraulic fluid sight gauge has been reached (approx. 12.5 gal.). (fig. 4-57,4-58)

Note: When checking or adding to the hydraulic fluid level, do so with the lift arms in the lowered position. If the level is checked with the lift arms in the raised position, an inaccurate reading will result.

Note: When adding hydraulic fluid, add fluid slowly until it is visible in the sight gauge. Once visible, add fluid in one quart increments until the full mark has been reached.

10. Install and secure the hydraulic reservoir filler cap.
11. Start the machine and operate all hydraulic circuits to work any trapped air out of the system.
 - Drive the machine forward and backward.
 - Raise and lower the lift arms(unloaded).
 - Dump and curl bucket/quick attach.

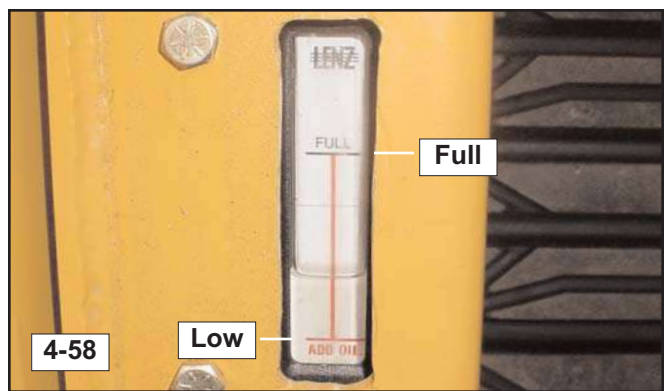
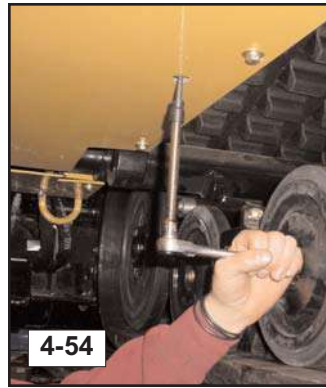

12. Once you have purged the air from the system, check the level on the hydraulic fluid level sight gauge. If the level is low repeat step 9 and 10 to complete the procedure.

Radiator/Oil Cooler

The Radiator and Oil Cooler must be kept clean to ensure proper operation. Engine and hydraulic system overheating, damage and even failure can result if the radiator/oil cooler is not kept clean. A pressure washer or compressed air nozzle work well to blow debris clear of the fins in the oil cooler and radiator.

Note: If hydraulic oil or engine coolant temperature gauges indicate abnormally high temperatures during operation, increase cleaning intervals.

Note: In brush cutting applications check and clean the coolers often to avoid overheating.

To clean radiator/oil cooler:

1. Make sure the engine is **off, and cool**.
2. Using compressed air or a pressure washer, thoroughly clean radiator/oil cooler as shown.

Note: Make sure water nozzle is at least 12" (8" for air) from the cooler and that the spray is directed straight through the cooler or the cooling fins may be damaged (bent over) which will decrease cooling performance.

Engine

Periodic cleaning of the chassis area beneath the cab and engine compartment are also necessary to maintain safe operation. Clean as required.

1. Remove the belly pans on the underside of the machine.
2. Tilt the cab up and raise the hood at the rear of the machine.
3. Pressure wash any debris from the engine compartment and chassis area out through the lower opening.

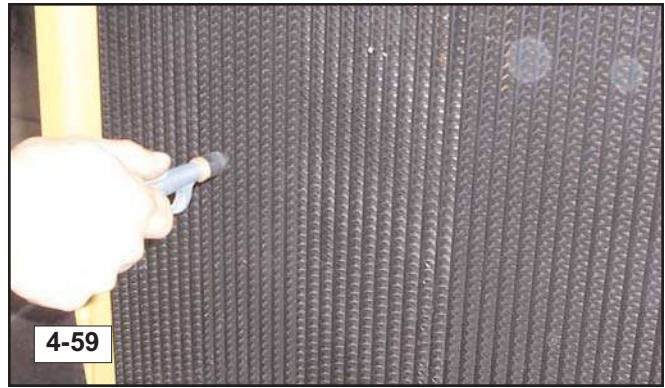

4. Maintenance



Case Drain Filter

The SR machines are also equipped with a filter in the auxiliary circuit case drain line. It protects the main hydraulic system in the event of catastrophic failure in an attachment. This filter is designed to last the life of the vehicle. The only instance where this filter should be replaced is if an attachment equipped with a case drain has a drive motor failure during use. (fig. 4-62)



Fuse Panel

The electrical systems in the SR machines are equipped with fuses that protect the electrical components from damage. They are located on the fuse panel behind the access cover on the lower right side of the cab interior. (fig. 4-63)

In the event of an electrical malfunction, the most logical place to start is at the fuse panel. Check the fuse related to the problem you are having and inspect it. If the fuse appears black and burned, it needs to be replaced. Replace fuses with the correct amperage replacement fuse only. Replacing a fuse with one of a lower amperage rating may lead to premature fuse failure. Replacing a fuse with one of a higher amperage rating may burn out the electrical component the fuse was meant to protect. See the troubleshooting section in this manual for an additional resource to aid in tracking suspected electrical problems.

<u>Maintenance Item</u>	<u>Service required</u>	<u>Interval</u>	<u>Notes</u>	<u>Service Capacity</u>
Grease fittings	Lubricate	Daily	Grease often.	
Fluid levels	Check	Daily	Adjust levels as necessary.	
Fan-A/C belt tension	Check	Daily	Adjust tension as necessary.	
Fan-A/C belt condition	Inspect	Daily	Replace as a pair if worn or damaged.	
Water separator	Drain	Daily		
Track condition	Inspect	Daily	Replace if severely damaged.	
Track tension	Inspect	Daily	Adjust tension as necessary.	
Air cleaners	Inspect	Daily	Replace if damaged or heavily soiled.	
Radiator/oil cooler	Inspect	Daily	Clean often (as necessary).	
Undercarriages	Inspect	Daily	Clean often (as necessary).	
Engine compartment	Inspect	Daily	Clean often (as necessary).	
Drive sprocket rollers	Inspect	50 hr.	Replace if damaged or worn. (35% min.)	
Engine oil and filter	Replace	12 Mo. or 500 hr.	Harsh conditions (6 Mo./250 hr. interval)	9 qt.
Hydraulic filters (2)	Replace	250 hr.	Replace filters as a pair.	
Hydraulic oil	Replace	500 hr.	Service refill capacity only. (Dry: 21 gallons)	12.25 gal.
Water separator-fuel filter	Replace	500 hr.	Replace fuel filter element.	
Radiator coolant	Replace	3000 hr.	Coolant with SCA additive required.	3.125 gal
Case drain filter	None required	N/A	Replace if attachment drive motor fails.	

5. Machine Controls and Instrumentation

Chapter Overview

This chapter contains an overview of the machine controls and instrumentation. For further information regarding machine controls, instrumentation or operation, refer to the operation and maintenance manual for the SR-70/80. Included here are illustrations of the following controls and instrumentation components and a description of their functions.

- Machine Controls
- Gauge Location and Function
- Switch Location and Function

Machine Controls (fig. 5-1)

There are three primary machine controls: lift arm control (1), drive control (2) and throttle (3).

Lift Arm Control

The lift arm control (1) is a pilot operated joystick that allows the operator to raise or lower the lift arms and dump or curl the quick attach mechanism.

Drive Control

The drive control (2) is also a pilot operated joystick. It allows the operator to change the direction and speed of the machine.

Throttle

The foot throttle (3) controls engine rpm.

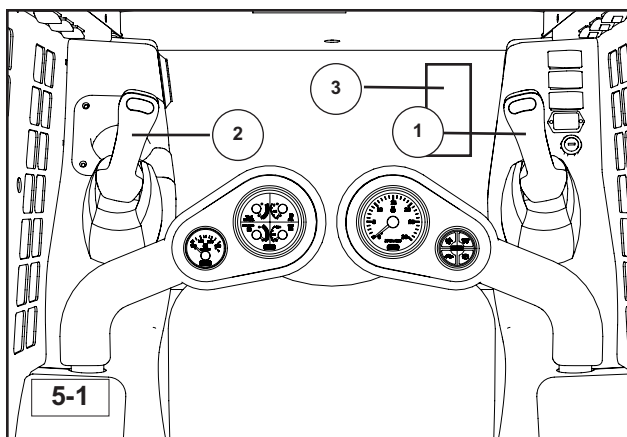

Instrumentation

The Instruments (Figure 5-2) are positioned in the lap bar for good visibility and when seated inside the operator enclosure. Instruments include the following components.

- (1) Engine Temperature Gauge
- (2) Multi-Gauge
 - Oil Pressure Gauge
 - Hyd. Oil Temperature Gauge
 - Fuel Gauge
 - Voltmeter
- (3) Tachometer
- (4) Indicator Light Display
 - High Range Indicator
 - Low Range Indicator
 - Glow Plug Operation Indicator
 - Parking Brake Indicator

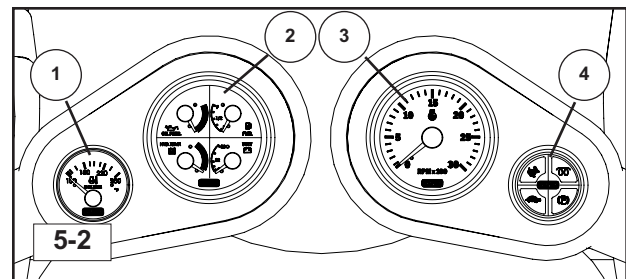

NOTICE

If the engine coolant temperature, engine oil pressure or hydraulic oil temperature gauges read above normal (or below normal for engine oil pressure) during normal machine operation, shut the machine down immediately. Diagnose the problem and make any necessary repairs before continuing to operate the machine.

NOTICE

If the battery low-voltage light illuminates, drive the machine to a suitable location and shut the engine off. Diagnose the problem and make needed repairs before continuing to operate.

The glow plug operation light illuminates only when the key switch is turned to engine pre-heat, showing normal operation.

Switches

The various switches (Figure 5-3, 5-4, 5-5) are positioned to provide good access and visibility. The standard and optional switches are listed below.

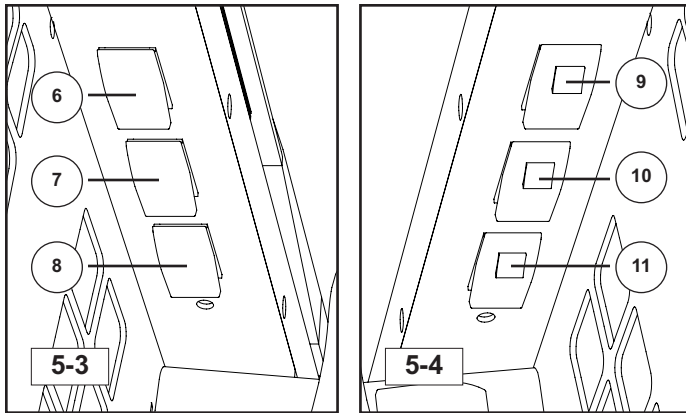

- (1) Ignition
- (2) Hour Meter
- (3) Beacon (optional)
- (4) Wiper (optional)
- (5) Heater Fan (optional)
- (6) Parking Brake
- (7) Headlight
- (8) Bucket Pos.
- (9) High Flow Aux.
- (10) Low Flow Aux.
- (11) Hyd. Q/A

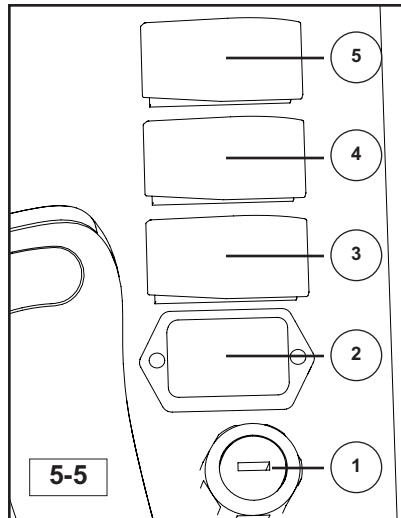

6. Operator Enclosure

Chapter Overview

This chapter provides information on the assembly and disassembly of the operator enclosure assembly. If there is an issue that requires troubleshooting, refer to Chapter 18, Troubleshooting.

Personal Safety

!WARNING!

Improper or incomplete maintenance/repair of a Rubber Track Loader can be dangerous and may result in machine damage, injury or even death.

Do not attempt to perform any type of repair or maintenance on a Rubber Track Loader until you have read and fully understood the information in this manual.

Refer to the Operation and Maintenance manual for instructions regarding proper machine operation techniques before operating any Rubber Track Loader.

Prior to performing any type of service work on a Rubber Track Loader, read and understand Chapter 1 (Product Safety) for personal safety information.

Machine Preparation

!WARNING!

Accidental machine starting can cause injury or even death to personnel working on a Rubber Track Loader.

As a precaution, disconnect the battery cables from the battery terminals, tape the battery clamps and remove the key from the ignition switch prior to performing any service work on a Rubber Track Loader.

Place a "Do Not Operate" tag prominently on the machine to inform personnel that the machine is being worked on.

Removal and Installation

Removal and installation procedures are provided for the following operator enclosure components.

- Cab Door Gas Spring
- Forward Pillar Switch Panels
- Gauge Clusters
- Seat
- Interior panels (right, left, and rear)
- Lap Bar Gas Assist Spring

Note: Procedures are provided for only the operator enclosure components listed above. However, exploded parts diagrams exist in the SR-70 or SR-80 Parts manuals to serve as visual aids in the removal or installation of other operator enclosure components.

Required Tools

Blade Type Screwdriver

Door Gas Spring

Removal



1. Pry the retaining clip holding the forward end of the gas spring to the ball stud outward. (fig. 6-1)



2. Pry the gas spring off of the ball stud. (fig. 6-2)
3. Repeat this procedure on the rear of the gas spring to remove the spring completely.

Installation

1. To reinstall, reverse the removal procedure.

Pillar Switch Panels Removal (RT or LT panel)

Required Tools
Open or Box end Wrenches



1. Remove the 3 screws/bolts securing the pillar switch panel to the cab enclosure. (fig. 6-3)



2. Remove the forward end of the gas spring from the ball stud by following steps 1-2 in the Cab Door Gas Spring removal procedure on page 6-1. Then remove the ball stud. (fig. 6-4)



3. Once the ball stud has been removed, begin removing the panel by pulling back on the top to expose the wires connected to the dome light activation switch. Carefully disconnect them from the switch. (fig. 6-5)

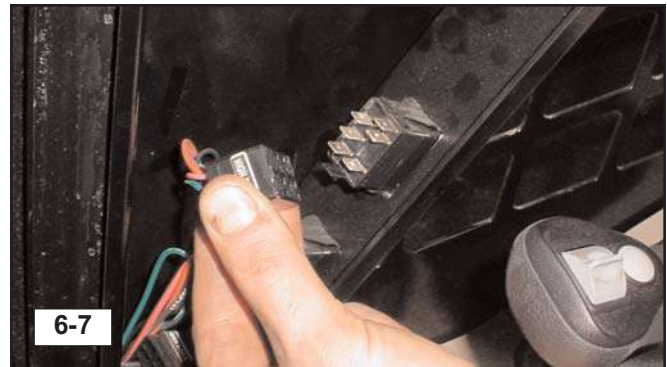
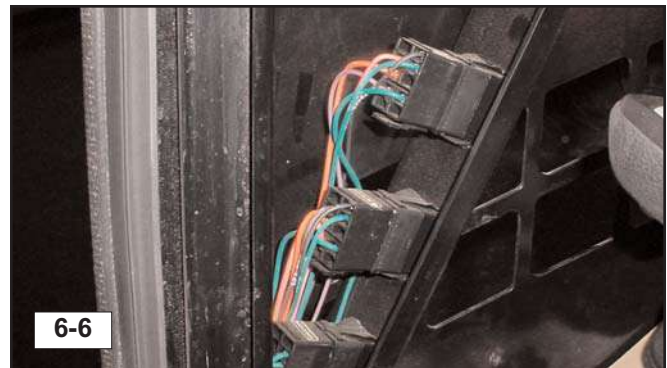

4. Pivot the panel further backward to expose the connectors on the lower switches and disconnect them. You may then remove the panel. (fig. 6-6, 6-7)

Note: The connectors on the harness are labeled as are the switches in the panel. Use these labels to properly identify (match up) and reconnect the harness to the switches during installation.

Note: At this point in the disassembly process, the activation switches in the panel may be removed and replaced if necessary. (fig. 6-8)



Installation (RT or LT panel)

1. To reinstall either panel, reverse the steps of the removal procedure.

Gauge Clusters

Removal

Required Tools
Phillips Type Screwdriver
Combination/Socket Wrench

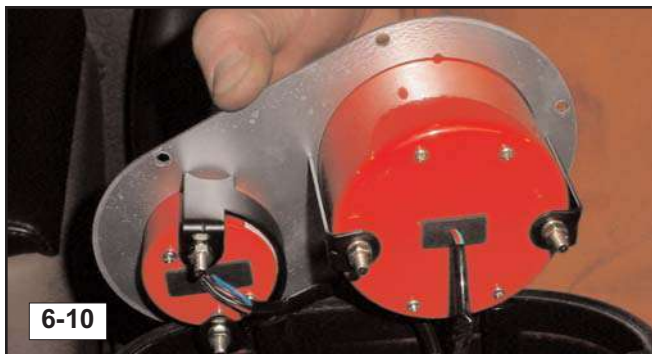

1. Remove the mounting screws securing the gauge mounting plate to the lap bar gauge pod, then raise the plate to expose the wire harness connectors. (fig. 6-9, 6-10)

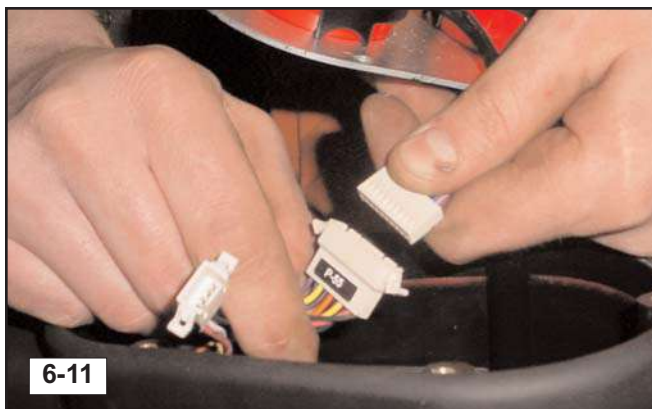

2. Disconnect the gauges from the harness and remove the gauge cluster. (fig. 6-11)

Note: At this point in the disassembly procedure, the gauges may be replaced if necessary.

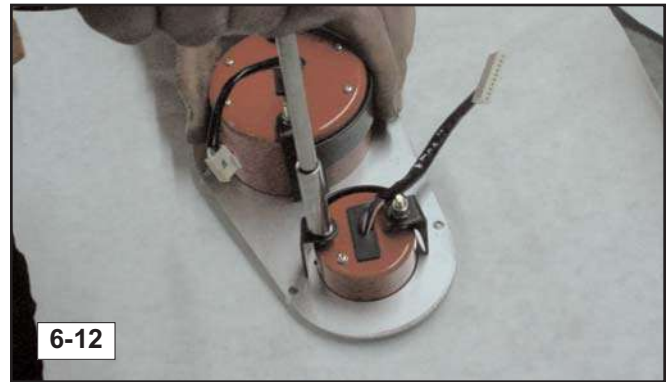

3. If gauges must be removed, remove the nuts securing the backing plate to the gauge. (fig. 6-12)

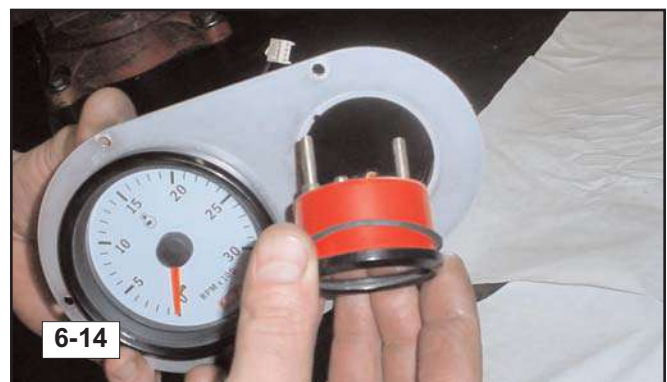
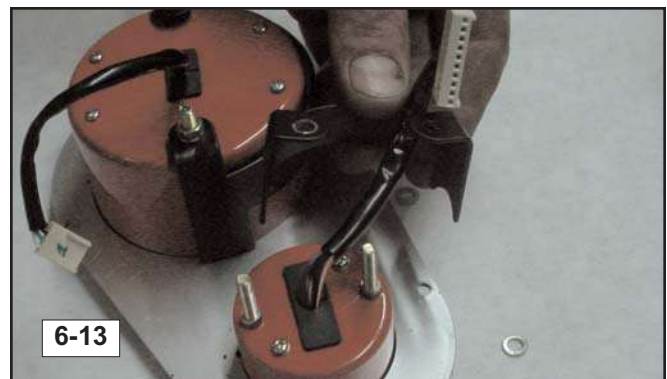

4. The gauge may now be removed for repair or replacement. (fig. 6-13, 6-14)

Installation

1. To reinstall the gauges and cluster, reverse the removal procedure.

Seat Removal

Required Tools

Combination/Socket Wrench

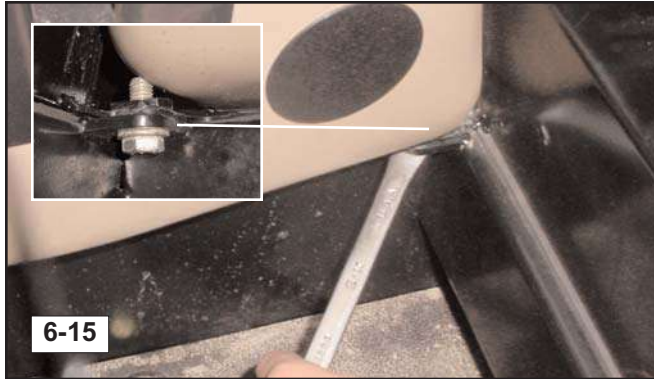

1. Remove the bolts (2) securing the cab to the chassis. They are located inside the cab in the upper front corners of the foot well. (fig. 6-15)
2. Raise and secure the cab as described on page 4-2 of this manual.

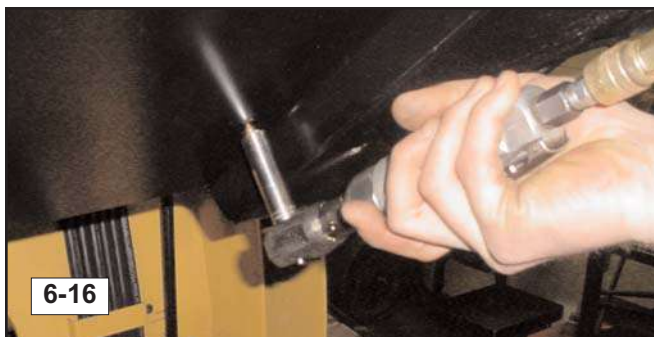

3. Remove the four nuts securing the seat to the cab.



4. Remove the seat partially to expose the seat switch harness located behind the seat. (fig. 6-17)



5. Disconnect the harness and then remove the seat from the machine. (fig. 6-18)

Seat Installation

1. To install the seat, reverse the removal procedure.

Interior Side Panel, LT Removal

Required Tools

Phillips Type Screwdriver



1. Remove the mounting screws (5) and washers securing the panel to the chassis. (fig. 6-19)



2. Remove the cup holder mounting screws (4) and remove the cup holder from the panel. (fig. 6-20)



6-21

3. Remove the panel by lifting and twisting it over the joystick and clear of the lap bar. (fig. 6-21)

Installation

1. To reinstall the left interior side panel, reverse the removal procedure.

Interior Side Panel, RT Removal

Required Tools
Phillips Type Screwdriver



6-22

1. Remove the fuse panel access cover. (fig. 6-22)



6-23

2. Remove the mounting screws (6) and washers securing the panel to the chassis. (fig. 6-23)

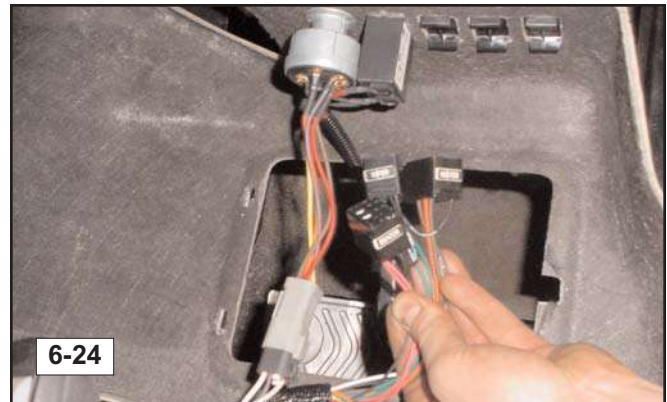

6-24

3. Disconnect the ignition switch, hour meter, and any other switches from the cab harness. (fig. 6-24)



6-25

4. Remove the panel by lifting and twisting it over the joystick and clear of the lap bar. (fig. 6-25)

Installation

1. To re-install the right interior side panel, reverse the removal procedure.

Rear Interior Panel

Removal

Required Tools
Phillips Type Screwdriver

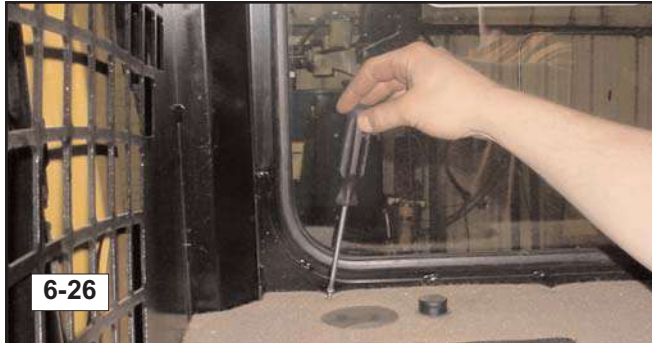

1. Remove the screws holding the rear panel to the cab. (fig. 6-26)



2. Disconnect the rear power point from the harness, then remove the panel from the cab. (fig. 6-27)

Installation

1. To re-install the rear interior panel, reverse the removal procedure.

Lap Bar Gas Spring

Removal

Required Tools
Phillips & Blade Type Screwdrivers

1. Remove the right, left and rear interior panels from the cab to access the gas spring.



2. Put the lap bar in the raised position to relieve tension on the lap bar gas spring. (fig. 6-28)



3. Using a small screwdriver, remove the retaining clip from each end of the gas spring. (fig. 6-29)
4. Remove the gas spring by pulling both ends off of the ball joints.

Installation

1. Reverse the removal procedure to reinstall the lap bar gas spring.

7. Chassis and Fuel Tank

Chapter Overview

This chapter provides information on the assembly and disassembly of the chassis. If there is an issue that requires troubleshooting, refer to Chapter 18, Troubleshooting.

Personal Safety

!WARNING!

Improper or incomplete maintenance/repair of a Rubber Track Loader can be dangerous and may result in machine damage, injury or even death.

Do not attempt to perform any type of repair or maintenance on a Rubber Track Loader until you have read and fully understood the information in this manual.

Refer to the Operation and Maintenance manual for instructions regarding proper machine operation techniques before operating any Rubber Track Loader.

Prior to performing any type of service work on a Rubber Track Loader, read and understand Chapter 1 (Product Safety) for personal safety information.

Machine Preparation

!WARNING!

Accidental machine starting can cause injury or even death to personnel working on a Rubber Track Loader.

As a precaution, disconnect the battery cables from the battery terminals, tape the battery clamps and remove the key from the ignition switch prior to performing any service work on a Rubber Track Loader.

Place a "Do Not Operate" tag prominently on the machine to inform personnel that the machine is being worked on.

Removal and Installation

Removal and installation procedures are provided for the following chassis components.

- Fuel Sending Unit
- Fuel Tank
- Footwell
- Foot Throttle Assembly
- Hood Assembly

Note: Procedures are provided for only those chassis components listed above. However, exploded parts diagrams exist in the SR-70 or SR-80 Parts manual to serve as visual aids in the assembly and disassembly of other chassis components.

Required Tools

Screwdriver

Combination/Socket Wrench

Fuel Sending Unit

Removal

1. Raise and support the lift arms as described on page 4-1 of this manual.
2. Tilt and support the operator enclosure (cab) as described on page 4-2 of this manual. (optional)

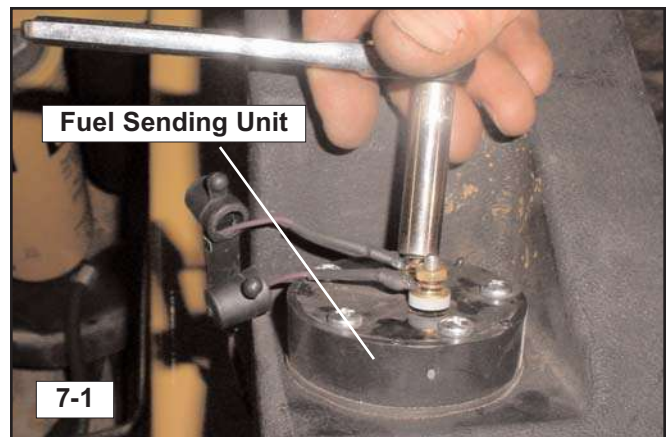

3. Locate the fuel sending unit on the left side of the machine in the upper front corner of the fuel tank. (fig. 7-1)
4. Remove the nuts and associated hardware securing the leads to the sending unit. (fig. 7-1)

Note: Record the order of assembly and polarity of the leads to ensure proper function when reassembled.

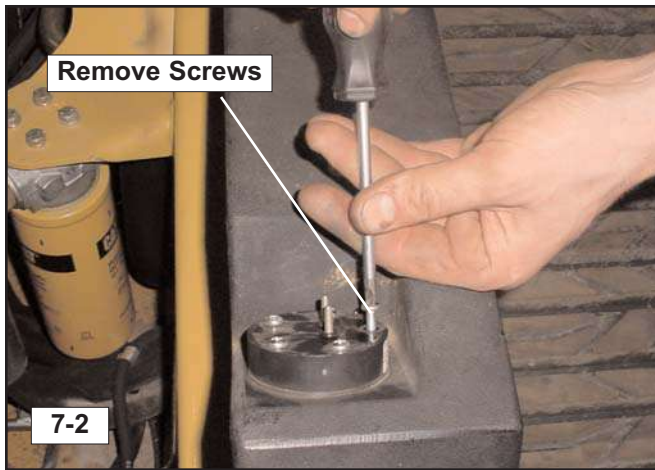

5. Remove the screws securing the fuel sending unit to the tank. (fig. 7-2)

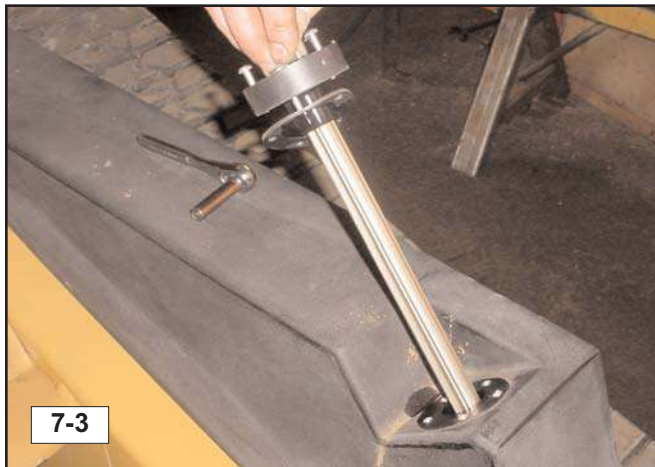

6. Remove the sending unit by pulling it through the opening in the fuel tank. (fig. 7-3)

Installation

1. To install the fuel sending unit, reverse the removal procedure. (See fig. 7-4 for terminal installation)

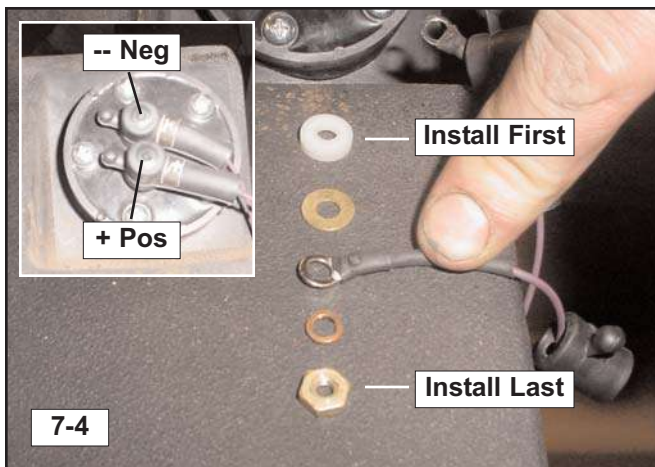

Fuel Tank Removal

Required Tools
Screwdriver
Combination/Socket Wrench

1. Raise and support the lift arms as described on page 4-1 of this manual.
2. Tilt and support the operator enclosure (cab) as described on page 4-2 of this manual. (optional)



3. Loosen the hose clamps securing the vent hoses to the left rear tank end. (fig. 7-5)



4. Disconnect and plug the hoses. (fig. 7-6)



5. Remove the bolts securing the forward belly pan and remove it from the machine. (fig. 7-7)



6. Loosen the hose clamp securing the main fuel line to the tank outlet in the front right corner of the machine. (fig. 7-8)



9. Remove the bolts (3) securing the fuel tank to the front mounting plate. (fig. 7-11)



7. Disconnect this line and drain the fuel into a suitable catch container. (fig. 7-9)



10. Now that the tank is loose and empty, loosen the hose clamp and disconnect the filler tube from the right rear end of the tank. (fig. 7-12)

Note: Collect and contain flammable liquids in suitable containers. Dispose of all liquids in accordance with local regulations and mandates.



8. Remove the bolts securing the fuel tank to the fenders. (fig. 7-10)

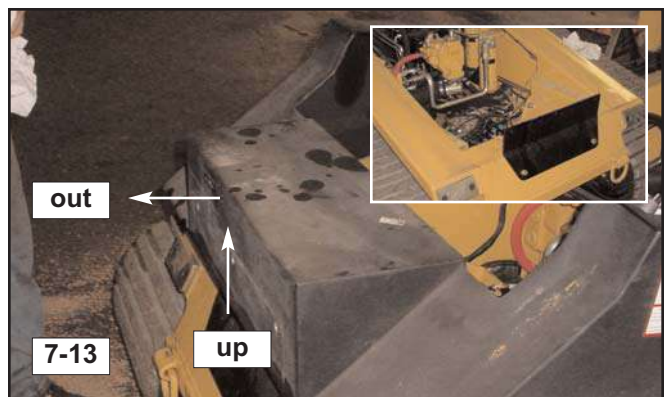

11. Lift and remove the tank from the machine. (fig. 7-13)

Installation

1. To install the fuel tank, reverse the removal procedure.

Footwell Removal

Required Tools

Screwdriver

Combination/Socket Wrench

1. Raise and support the lift arms as described on page 4-1 of this manual. (optional)
2. Tilt and support the operator enclosure (cab) as described on page 4-2 of this manual.



3. Remove the bolts (4) securing the foot pedal cover to the pedal, then remove the cover. (fig. 7-14)

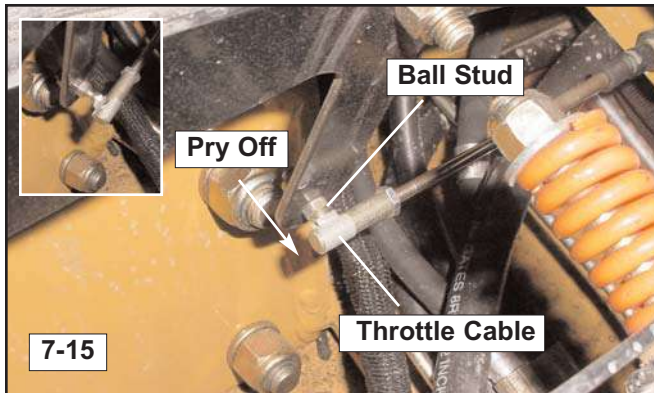

4. Pry the throttle cable off of the ball stud on the foot pedal. (fig. 7-15)

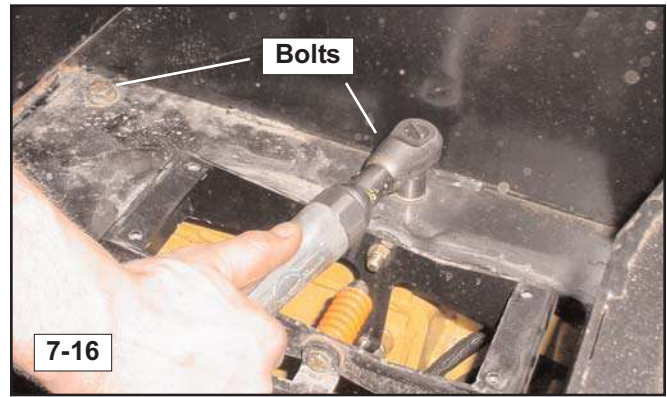

5. Remove the bolts (4) securing the footwell assembly to the chassis. (fig. 7-16)



6. Remove the footwell from the chassis as shown. (fig. 7-17)

Installation

1. To install the footwell, reverse the removal procedure.

Foot Throttle Assembly Removal

Required Tools

Screwdriver

Combination/Socket Wrench

Note: The foot throttle assembly may be removed with the footwell still installed in the machine.

1. Perform steps 3 and 4 of the footwell removal procedure on page 7-4.

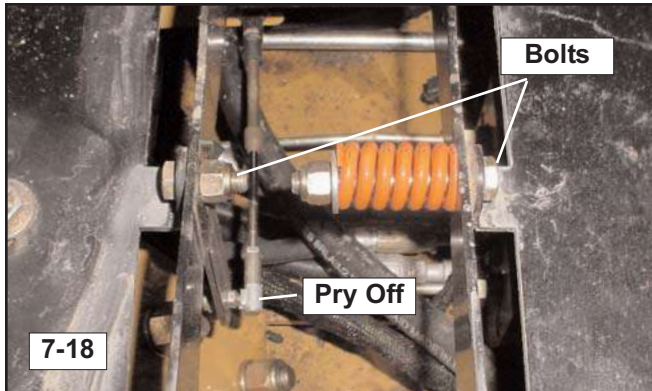

2. Remove the bolts (2) and associated hardware securing the foot throttle assembly to the footwell. (fig. 7-18)

Note: Record the order of assembly during removal to ensure proper operation when re-installed.

3. Remove the foot throttle from the machine.

Installation

1. To install the foot throttle assembly, reverse the removal procedure.

Hood Assembly Removal

Required Tools

Screwdriver

Combination/Socket Wrench

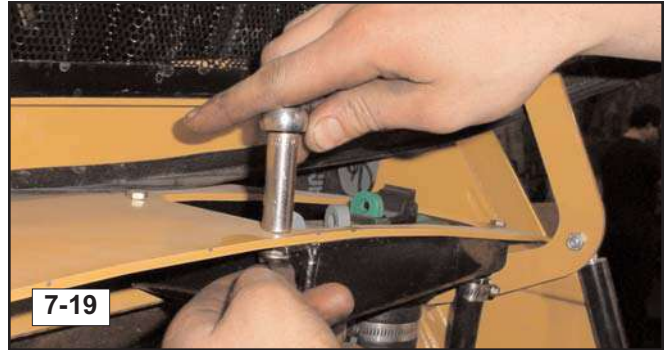

1. Remove the bolts (4) securing the fluid filler tray and hoses to the hood assembly. (fig. 7-19, 7-20)

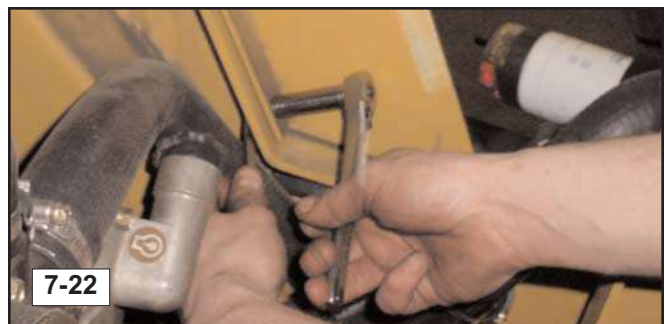

2. Remove the bolts (6) that secure the hood to the chassis. (fig 7-21, 7-22)



3. Have an assistant help you to remove the hood assembly from the machine. (fig. 7-23)



4. Carefully set the hood assembly aside. (fig. 7-24)

Installation

1. To install the hood assembly, reverse the removal procedure.

8. Radiator and Oil Cooler

Chapter Overview

This chapter provides information on the disassembly and assembly of the radiator/oil cooler and associated components. If there is an issue that requires troubleshooting, refer to chapter 18, Troubleshooting.

Personal Safety

!WARNING!

Improper or incomplete maintenance/repair of a Rubber Track Loader can be dangerous and may result in machine damage, injury or even death.

Do not attempt to perform any type of repair or maintenance on a Rubber Track Loader until you have read and fully understood the information in this manual.

Refer to the Operation and Maintenance manual for instructions regarding proper machine operation techniques before operating any Rubber Track Loader.

Machine Preparation

!WARNING!

Accidental machine starting can cause injury or even death to personnel working on a Rubber Track Loader.

As a precaution, disconnect the battery cables from the battery terminals, tape the battery clamps and remove the key from the ignition switch prior to performing any service work on a Rubber Track Loader.

Place a "Do Not Operate" tag prominently on the machine to inform personnel that the machine is being worked on.

Prior to performing any type of service work on a Rubber Track Loader, read and understand Chapter 1 (Product Safety) for personal safety information.

Removal and Installation

Removal and installation procedures are provided for the following radiator/oil cooler components.

- Fan Guard
- Fan
- Fan Shroud
- Radiator/Oil Cooler

Note: Procedures are provided for only those radiator/oil cooler components listed above. However, exploded parts diagrams exist in the SR-70 and SR-80 Parts manuals to serve as visual aids in the assembly and disassembly of other system components.

Note: Refer to pages 3-1 and 3-2 for pictorial views of the filtering and cooling system components.

Fan Guard

Removal

Required Tools

- Combination Wrench
- Socket Wrench
- Socket Wrench Extension (optional)



1. Remove the air cleaner end cap and elements to provide clearance for guard removal. (fig. 1)

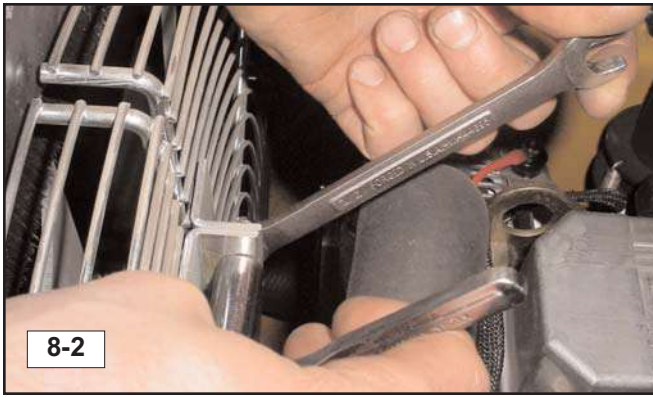

2. Remove bolts (5) securing the fan guard halves to the fan shroud. (fig. 8-2, 8-3)



3. Remove both halves of the guard from the machine. (LT side shown, fig. 8-4)

Installation

1. To install the fan guard halves, reverse the removal procedure.

Fan & Fan Shroud

Removal

Required Tools

Combination Wrench

Socket Wrench



1. Remove the bolts (2) securing the fuel pump/filter assembly to the radiator support and lay it aside over the bumper to allow clearance to remove the shroud and fan. (fig. 8-5)



2. Remove the bolts (6) securing the radiator and shroud to the radiator support. (fig. 8-6)



3. Push the shroud forward to allow access the fan mounting bolts. (fig. 8-7)



4. Remove the bolts securing the fan and spacer to the engine, then remove the fan and spacer from between the shroud and radiator as shown. (fig. 8-8, 8-9)



5. Remove the radiator shroud from the machine. (fig. 8-10)

Installation

1. To install the fan and fan shroud, reverse the removal procedure.

Radiator/Oil Cooler

Removal

!WARNING!

Personal injury can result from exposure to hot fluids and components. Allow the machine to cool thoroughly before attempting any type of service on the cooling or hydraulic systems.

!WARNING!

Cooling system conditioner contains alkali. Avoid contact with skin and eyes.

NOTICE

Collect and contain liquids in suitable containers. Dispose of all liquids according to local regulations and mandates.

Required Tools

Socket Wrench
Pliers
Screwdriver
Hydraulic Caps/Plugs (various sizes)

1. Perform the fan guard and fan/shroud removal procedures.



2. Remove the bolts securing the rear belly plates to the chassis and remove them. (fig. 8-11)

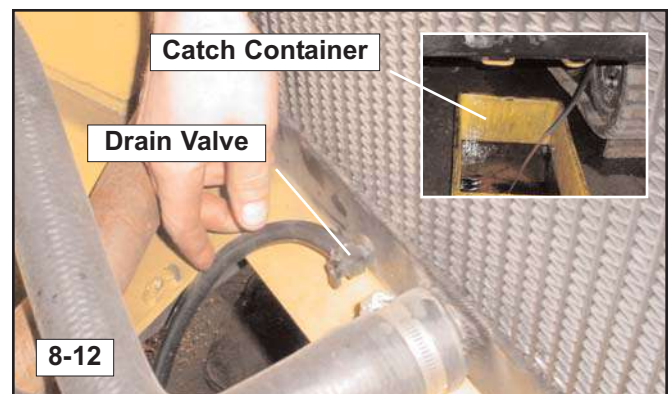

3. Attach a piece of 3/8" fuel line to the drain valve, outlet, then twist the valve control counter clockwise to drain the cooling system. (fig. 8-12)

Rubber Track Loader
8. Radiator and Oil Cooler



4. Remove the bolts (6) securing the outer shroud to the chassis, then remove the shroud. (fig. 8-13)



5. Remove the upper hydraulic cooler hose. Cap or plug the hose upon removal. (fig. 8-14)



6. Loosen and disconnect the lower hydraulic line from the cooler. Cap and plug the line and cooler opening upon disassembly. (fig. 8-15)

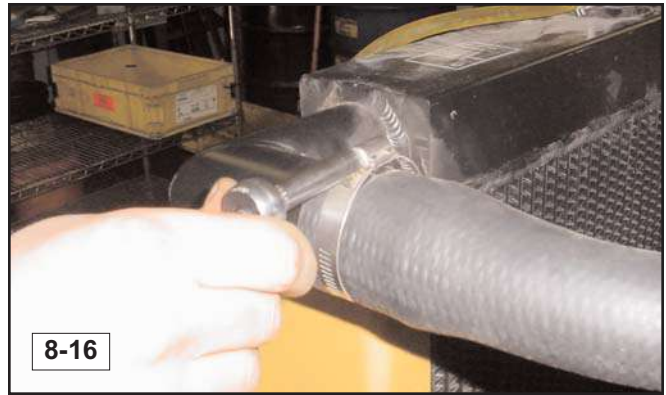

7. Loosen the clamps securing the upper and lower coolant hoses to the radiator, then disconnect the hoses from the radiator. (fig. 8-16, 8-17)



8. Tilt the radiator rearward and then remove it from the machine. (fig. 8-18)

Installation

1. To install the radiator/oil cooler, reverse the removal procedure.

9. Hydraulic Reservoir

Chapter Overview

This chapter provides removal and installation procedures for the hydraulic reservoir.

Personal Safety

!WARNING!

Improper or incomplete maintenance/repair of a Rubber Track Loader can be dangerous and may result in machine damage, injury or even death.

Do not attempt to perform any type of repair or maintenance on a Rubber Track Loader until you have read and fully understood the information in this manual.

Refer to the Operation and Maintenance manual for instructions regarding proper machine operation techniques before operating any Rubber Track Loader.

Machine Preparation

!WARNING!

Accidental machine starting can cause injury or even death to personnel working on a Rubber Track Loader.

As a precaution, disconnect the battery cables from the battery terminals, tape the battery clamps and remove the key from the ignition switch prior to performing any service work on a Rubber Track Loader.

Place a "Do Not Operate" tag prominently on the machine to inform personnel that the machine is being worked on.

Prior to performing any type of service work on a Rubber Track Loader, read and understand Chapter 1 (Product Safety) for personal safety information.

Removal and Installation

Removal and installation procedures are provided for the following hydraulic components.

- Hydraulic Reservoir (tank)
- Suction Screen

Note: Procedures are provided for only those hydraulic components listed above. However, exploded parts diagrams exist in the SR-70 and SR-80 Parts manuals to serve as visual aids in the removal and installation of other system components.

Note: Refer to pages 3-1, 3-2 and 3-3 for additional hydraulic circuit and system information.

Hydraulic Reservoir

Removal (in event of contamination)

Required Tools

Screwdriver
Combination/Socket Wrench
Pry Bar(s)

!WARNING!

Remove any attachment, relax all actuators and make sure the hydraulic oil is cool before removing any components or lines. Hot or pressurized oil can cause personal injury.

NOTICE

Collect and contain liquids in suitable containers. Dispose of all liquids according to local regulations and mandates.

NOTICE

During disassembly, plug and cap all hoses and fittings to prevent system fluid loss or contamination.

Rubber Track Loader
9. Hydraulic Reservoir

1. Remove the center and rear belly pans from the machine.
2. Drain the hydraulic fluid. Refer to page 4-16 for the hydraulic fluid and filter change procedure.
3. Remove the engine as described on page 12-5 of this manual.
4. Remove the auxiliary and drive pumps (for inspection, repair, or replacement) according to the procedures in section 11 of this manual.

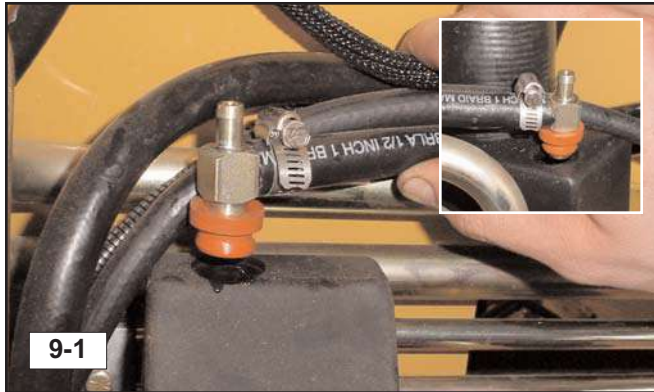

5. Disconnect the hoses and lines attached to the two upright portions of the tank. (fig. 9-1, 9-2, 9-3)

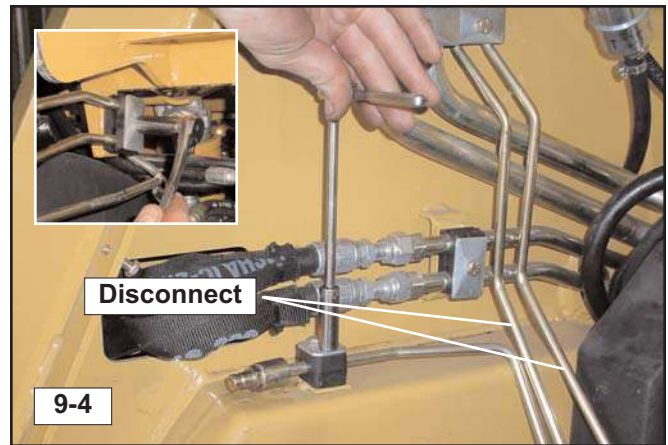

6. Remove the clamps securing the quick attach hard lines and the test port line that run from the pilot generation block down the left side of the machine to the engine compartment. (fig. 9-4)



7. Disconnect the quick attach hoses from the hard lines (if equipped). (fig. 9-5)

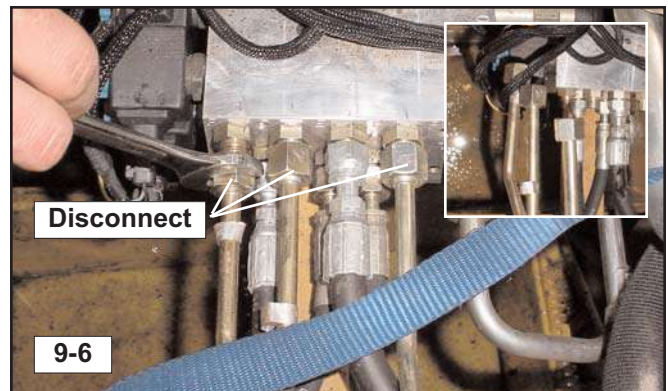

8. Disconnect the quick attach and test port lines from the pilot generation block. (fig. 9-6)



9. Gently move the hard lines out of the way to allow for reservoir removal then zip tie them to the motor mount to keep them secure. (fig. 9-7)

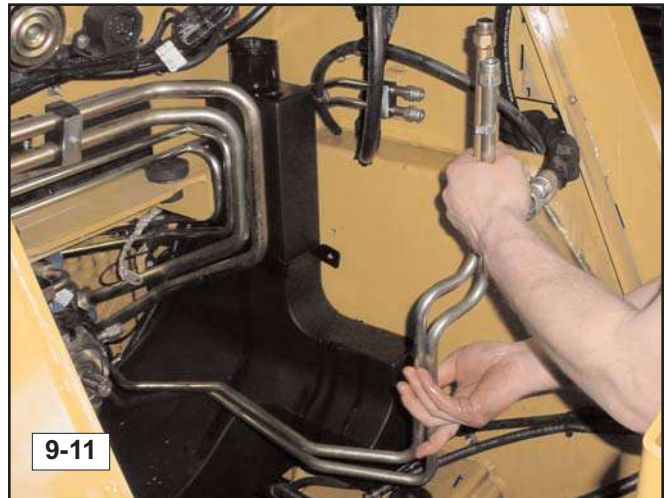
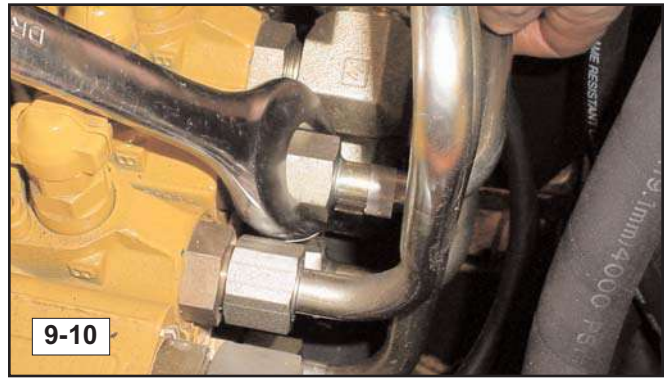

10. Disconnect the bucket cylinder hoses from the hard lines in the upper right portion of the engine compartment. Remove all line clamps. (fig. 9-8)



11. Disconnect the lift cylinder hoses from the hard lines to allow the bucket cylinder lines to be removed. (fig. 9-9)

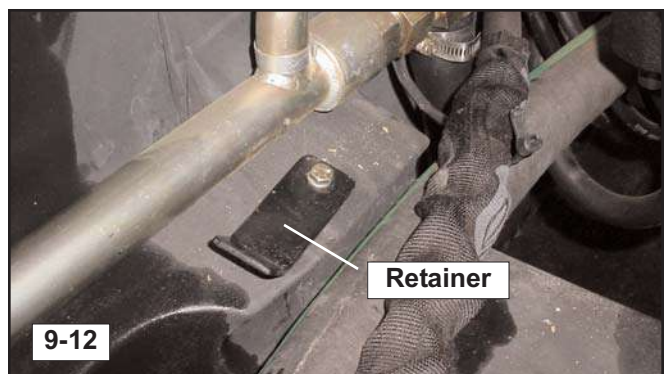

13. Remove the hose retainer or move it aside as shown. (fig. 9-12)

Rubber Track Loader
9. Hydraulic Reservoir

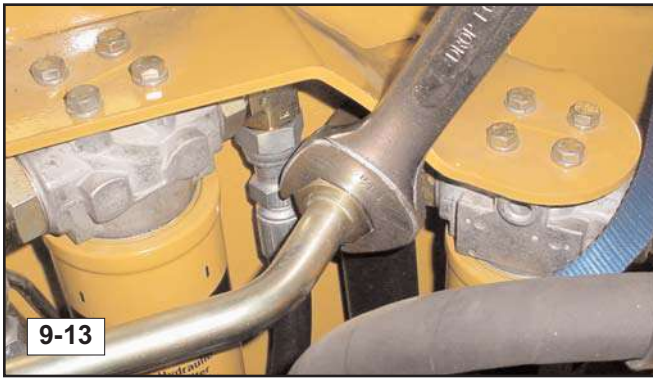

14. Disconnect the main oil cooler line from the fitting at the filter. (fig. 9-13)

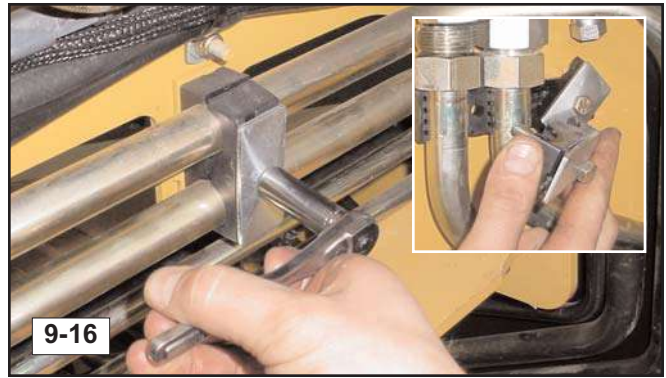

16. Remove the clamps securing the auxiliary hydraulic lines to the chassis. (fig. 9-16)

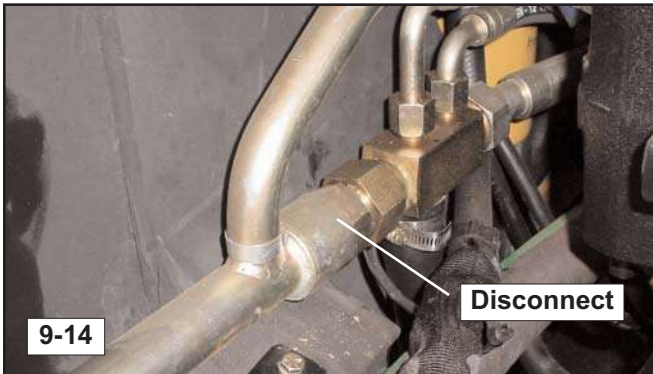

15. Disconnect the main oil cooler line from the junction block, then remove it from the machine. (fig. 9-14, 9-15)



17. Disconnect the auxiliary hydraulic lines from the lift arm control valve and the hoses leading to the quick coupler lines on the lift arm. (fig. 9-17, 9-18)



18. Slide the two fuel lines through the chassis opening and into the engine compartment so that the aux. hyd. tubes can be removed. (fig. 9-19, 9-20)



19. Disconnect the fuel sender from the main harness at the connector.

Note: If there is anything else that is routed behind the auxiliary hydraulic tubes that will prevent them from being removed, disconnect or carefully remove these items at this time to allow the tubes to be removed.



20. Remove the auxiliary hydraulic tubes from the machine.

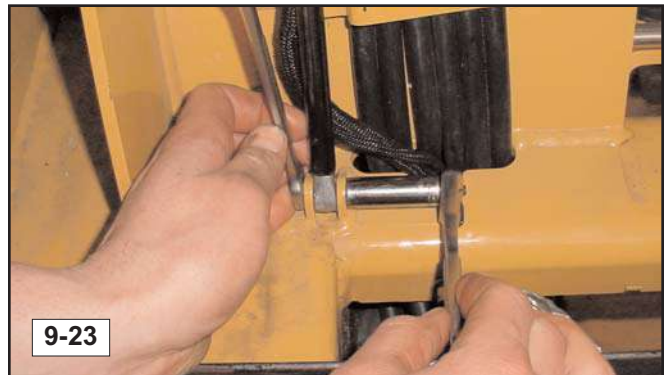

21. Disconnect the lower portions of the cab support gas springs from the chassis. (fig. 9-23)



22. Label, then disconnect any control hoses coming from the joysticks that are still attached to components to allow them to be pulled up through the chassis opening for clearance. (fig. 9-24)

Note: Refer to the individual hydraulic component removal and installation procedures if additional information is needed to properly connect hoses during reassembly.

Rubber Track Loader
9. Hydraulic Reservoir



23. Remove the lower hose restraints to allow the hoses to be pulled through the chassis. (fig. 9-25)

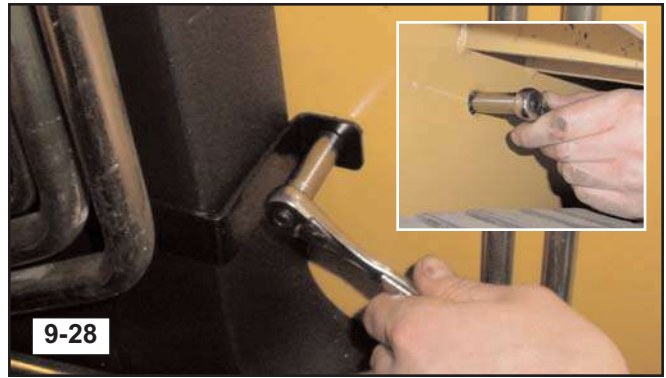

26. Remove the bolts securing the metal tank restraint straps, then remove them from the machine. (fig. 9-28)



24. Pull the hoses up through the chassis opening and lay them aside as shown (both sides). (fig. 9-26)



27. Slide the quick attach and test port tubes forward so that they do not interfere with the reservoir (tank) moving upwards in the chassis. (fig. 9-29)

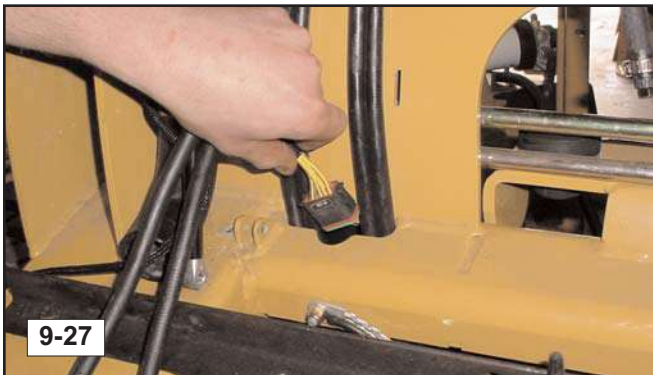

25. Disconnect the wiring running through the hose passageway and pull it through the opening as shown. (fig. 9-27)



28. Slide the various control hoses to the side of the reservoir (tank) so that they do not interfere with the tank moving upwards in the chassis. (fig. 9-30)

29. Make sure there is nothing that would visibly prevent the reservoir from being removed or is still attached to other components within the machine, then proceed.

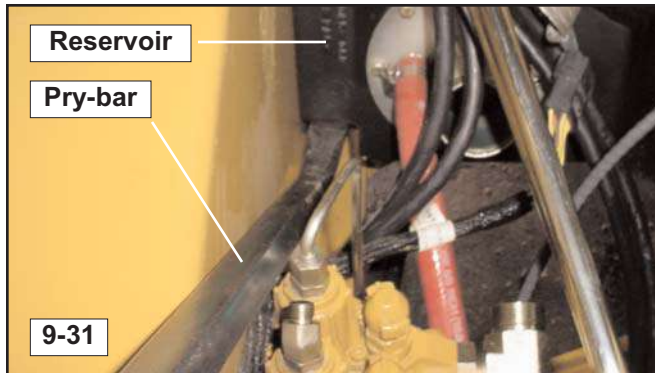

30. Use a long pry bar to pry the tank upward and rearward from the front as shown. (fig. 9-31)

Note: You may need to pry the tank upwards within the chassis from the rear if it isn't already to prepare the tank to be moved in step 30.



31. Once the tank is over the axle mounts lift and remove it from the chassis as shown. (fig. 9-32, 9-33, 9-34)

Installation

1. To install the hydraulic reservoir, reverse the removal procedure.

Note: The only service issue warranting the removal of the reservoir is hydraulic system contamination. Upon installation, the tank must be clean and free of **any** dirt or debris that may contaminate the hydraulic oil. If you are unable to successfully flush the tank clean of **all** dirt or debris, replace the tank.

Suction Screen

Removal

Required Tools
Small Pry Bar (hose removal if necessary)
Socket Wrench & Extension
Combination Wrenches (to remove lines)

Note: The suction screen may be removed with the reservoir (tank) still in the machine. If this is necessary, remove the center belly pan and tilt and support the cab to gain access, then follow the procedure described below to remove the suction screen.

1. If the tank is still in the machine, drain the hydraulic fluid as described on page 4-16 of this manual.
2. If the tank is still in the machine, remove/disconnect any hoses connected to the flange weldment that may interfere with removal.



3. Remove the bolts securing the flange to the hydraulic reservoir. (fig. 9-35)

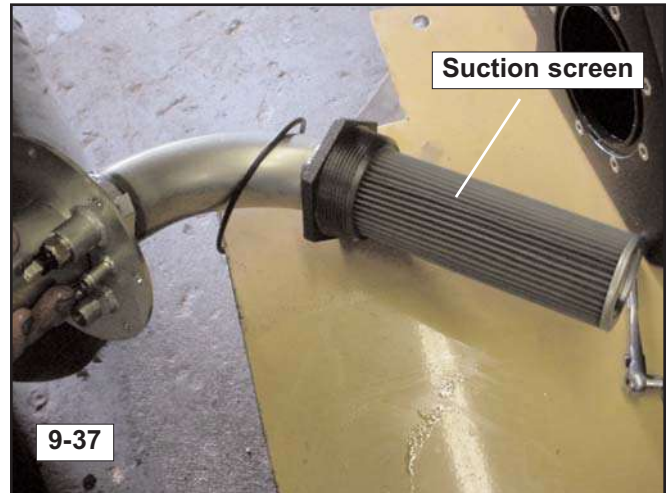
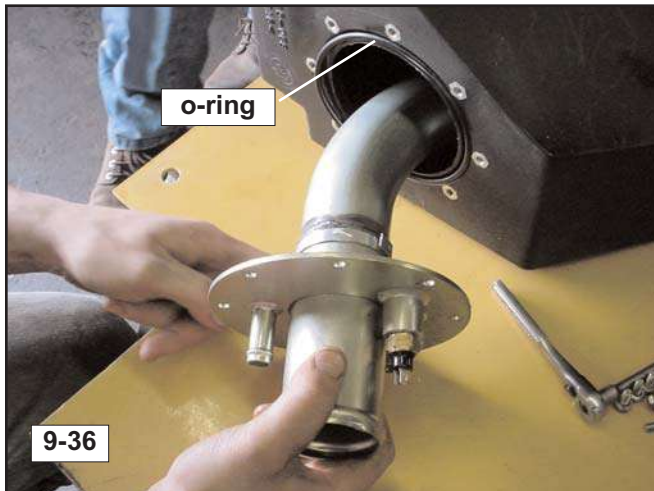

4. Slide the assembly out of the reservoir as shown in fig. 9-36 and 9-37.
5. The suction screen is now accessible for inspection or replacement.

Note: If removal is necessary, thread the suction screen off of the flange weldment and remove.

Installation

1. To install the suction screen, reverse the removal procedure.

Note: It is important to inspect the screen for pieces of metal or other debris that may have been generated by a worn or defective component. If there is debris present on the screen, the hydraulic system (including the reservoir) must be flushed clean to remove any and all contamination (debris). The screen should be replaced as well as any components found to be defective.

10. Lift-Arm/Drive Controls

Chapter Overview

This chapter provides removal and installation procedures for the lift-arm and drive control components.

Personal Safety

!WARNING!

Improper or incomplete maintenance/repair of a Rubber Track Loader can be dangerous and may result in machine damage, injury or even death.

Do not attempt to perform any type of repair or maintenance on a Rubber Track Loader until you have read and fully understood the information in this manual.

Refer to the Operation and Maintenance manual for instructions regarding proper machine operation techniques before operating any Rubber Track Loader.

Machine Preparation

!WARNING!

Accidental machine starting can cause injury or even death to personnel working on a Rubber Track Loader.

As a precaution, disconnect the battery cables from the battery terminals, tape the battery clamps and remove the key from the ignition switch prior to performing any service work on a Rubber Track Loader.

Place a "Do Not Operate" tag prominently on the machine to inform personnel that the machine is being worked on.

Prior to performing any type of service work on a Rubber Track Loader, read and understand Chapter 1 (Product Safety) for personal safety information.

Removal and Installation

Removal and installation procedures are provided for the following lift-arm/drive control components.

- Pilot Control Joystick
- Lift Arm Float Magnet
- Lift Arm Control (loader) Valve

Note: Procedures are provided for only those lift-arm/drive control components listed above. However, exploded parts diagrams exist in the SR-70 and SR-80 Parts manuals to serve as visual aids in the assembly and disassembly of other system components.

Note: Refer to page 3-2 and 3-3 for pictorial views of the hydraulic auxiliary and drive systems and components.

Pilot Control Joystick

Removal

Required Tools

Side Cutter
Combination/Open End/Socket Wrenches
Hydraulic Caps/Plugs (various sizes)

Note: The procedures for removing and installing the right and left joysticks are basically identical. As a result, only the procedures for the right joystick are described in this section.

NOTICE

Cap and plug all fittings and hoses to prevent fluid loss and or contamination during service work.

!WARNING!

Remove any attachment, lower the lift arms and make sure the hydraulic oil is cool before removing any components or lines. Hot or pressurized oil can cause personal injury.

10. Lift-Arm/Drive Controls

1. Relax all hydraulic actuators to relieve pressure in the hydraulic system prior to service.
2. Turn the ignition switch to the **OFF** position, remove the key and disconnect the battery to avoid accidental start.
3. Perform the interior side panel removal procedure that addresses the joystick you plan to remove on page 6-4 or 6-5 of this manual.



4. Expose and cut the zip tie securing the lower portion of the boot to the joystick body, then lift it upwards. (figure 10-1)

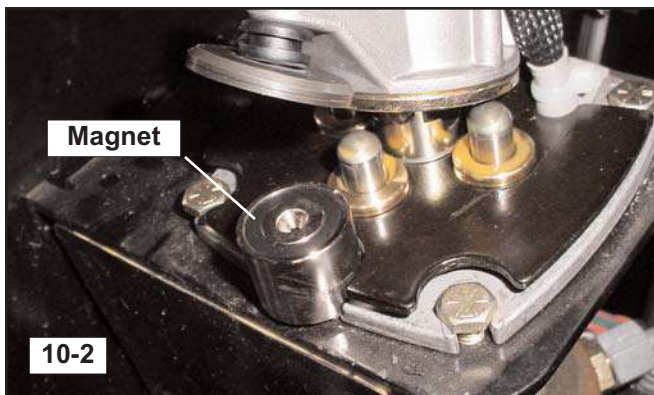

Note: The float magnet is now exposed as well as the mounting bolts securing the joystick to the bracket. (figure 10-2)

5. Label each of the hoses during the removal process to aid in reassembly.

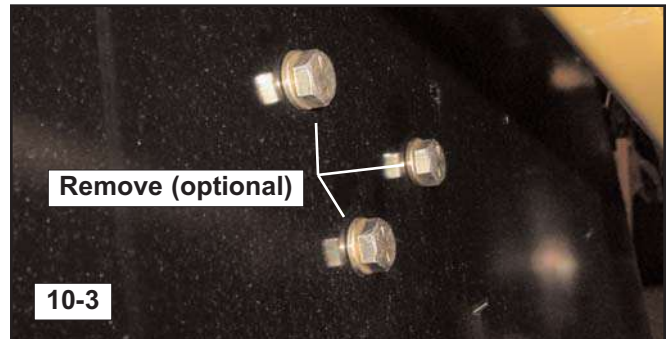

6. Remove the bolts (3) securing the joystick mounting bracket to the cab from the outside. (fig. 10-3) (optional)
7. Label the hydraulic hoses to aid in reassembly (see page 3-7 or 3-8 for routing and identification).



8. Disconnect the hydraulic hoses from the various joystick fittings and lay them aside. (fig. 10-4,10-5)



9. Disconnect all connectors coming from the joystick harness. (fig. 10-6)

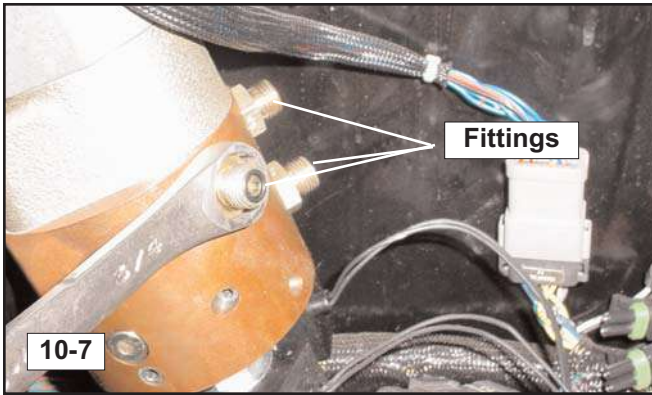

10. Remove the fittings on the back of the joystick (lift arm control joystick only). (fig. 10-7)



11. Remove the bolts and nuts securing the joystick to the mounting bracket. (fig. 10-8)



12. Lift the joystick through the opening in the bracket and remove it from the machine. (fig. 10-9)

Installation

1. To install the joystick, reverse the removal procedure.

Lift Arm Float Magnet Removal

Required Tools

Socket Wrench
Combination/Open End Wrench
Allen Wrench

1. Perform steps 3, 4 and 11 of the lift arm joystick control removal process.



2. Remove the allen bolt from the underside of the magnet. (fig. 10-10)

3. Disconnect the magnet harness connector from the machine.



4. Lift the joystick within the bracket slightly, then pull the magnet harness and connector through the bracket past the joystick to remove it. (fig. 10-11)

Installation

1. To install the float magnet, reverse the removal procedure.

Lift Arm Control Valve Removal

Required Tools

Socket Wrench
Combination/Open End Wrench
Screwdriver (hose clamps)

1. Perform the footwell removal procedure on page 7-4 of this manual.
2. Drain the hydraulic system as described on page 4-15 of this manual.



3. Label all lines and hoses as necessary to aid in reassembly. (fig. 10-12)

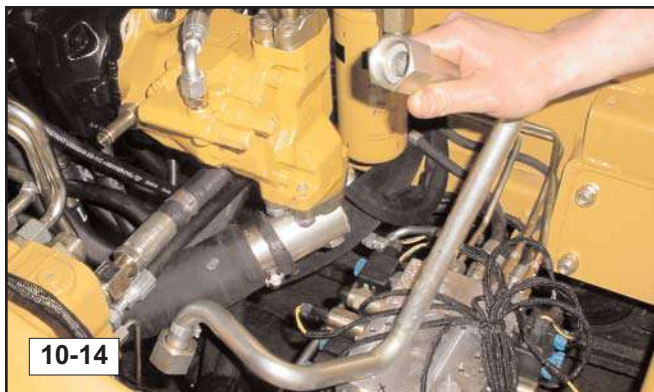

4. Disconnect the hose from the barb type fitting on the auxiliary pump and the large hard line that sweeps across the front of the pumps and connects to the filter head to provide additional clearance for line removal. (fig. 10-13, 10-14)



5. Disconnect all lines and hoses from the valve to allow for removal. (figure 10-15, 10-16)

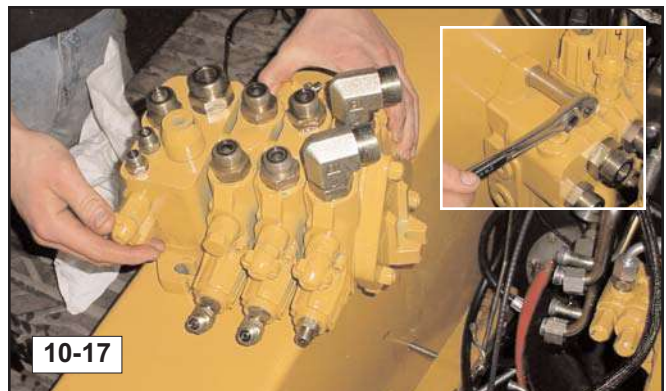

6. Remove the carriage bolts (3) securing the loader valve to the chassis. Then remove the valve.

Note: The bolts have a square shank that mates with a square hole in the chassis to keep them from rotating upon removal.

Installation

1. To install the lift arm control valve, reverse the removal procedure.

11. Hydraulic Pumps/Motors

Chapter Overview

This chapter provides removal and installation procedures for the hydraulic pumps and motors.

Personal Safety

!WARNING!

Improper or incomplete maintenance/repair of a Rubber Track Loader can be dangerous and may result in machine damage, injury or even death.

Do not attempt to perform any type of repair or maintenance on a Rubber Track Loader until you have read and fully understood the information in this manual.

Refer to the Operation and Maintenance manual for instructions regarding proper machine operation techniques before operating any Rubber Track Loader.

Machine Preparation

!WARNING!

Accidental machine starting can cause injury or even death to personnel working on a Rubber Track Loader.

As a precaution, disconnect the battery cables from the battery terminals, tape the battery clamps and remove the key from the ignition switch prior to performing any service work on a Rubber Track Loader.

Place a "Do Not Operate" tag prominently on the machine to inform personnel that the machine is being worked on.

Prior to performing any type of service work on a Rubber Track Loader, read and understand Chapter 1 (Product Safety) for personal safety information.

NOTICE

The hydraulic system fluid should be changed following any hydraulic component service according to the procedure described on page 4-16.

Removal and Installation

Removal and installation procedures are provided for the following hydraulic components.

- Charge Pump
- Auxiliary Pump
- Tandem (Drive) Pump
- Drive Motor

Note: Procedures are provided for only those hydraulic components listed above. However, exploded parts diagrams exist in the SR-70 and SR-80 Parts manuals to serve as visual aids in the removal and installation of other system components.

Note: Refer to pages 3-1, 3-2 and 3-3 for additional motor, pump and hydraulic system information.

Charge Pump Removal

Required Tools

Screwdriver
Combination Wrench
Socket Wrench

!WARNING!

Remove any attachment, relax all actuators and make sure the hydraulic oil is cool before removing any components or lines. Hot or pressurized oil can cause personal injury.

NOTICE

Collect and contain liquids in suitable containers. Dispose of all liquids according to local regulations and mandates.

NOTICE

During disassembly, plug and cap all hoses and fittings to prevent system fluid loss or contamination.

11. Hydraulic Pumps/Motors

1. Lower the lift arms to the ground and relax the bucket tilt/curl cylinders to relieve pressure within the hydraulic system.
2. Turn the ignition switch to the **OFF** position and remove the key to avoid accidental start.
3. Drain the hydraulic fluid. Refer to page 4-16 for the hydraulic fluid and filter change procedure.
4. Raise the hood at the rear of the machine.

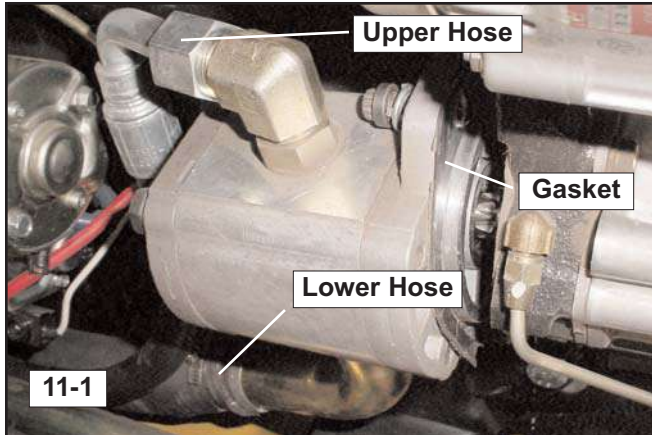

5. Disconnect the hose from the upper charge pump fitting. (fig. 11-1)
6. Loosen the hose clamp and disconnect the hose from the barb type inlet tube on the underside of the charge pump. (fig. 11-1)

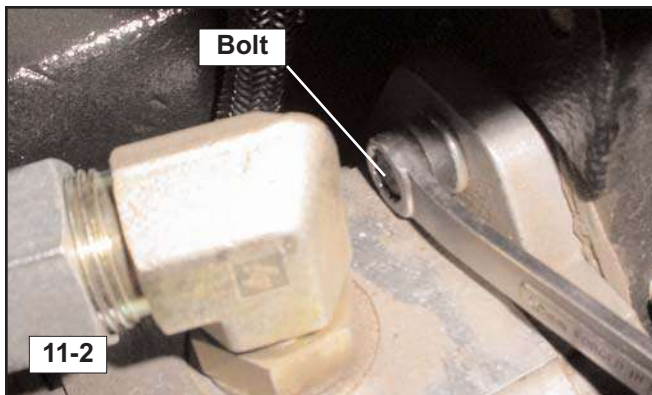

7. Remove the upper and lower 12 point bolts securing the charge pump to the engine. (fig. 11-2)

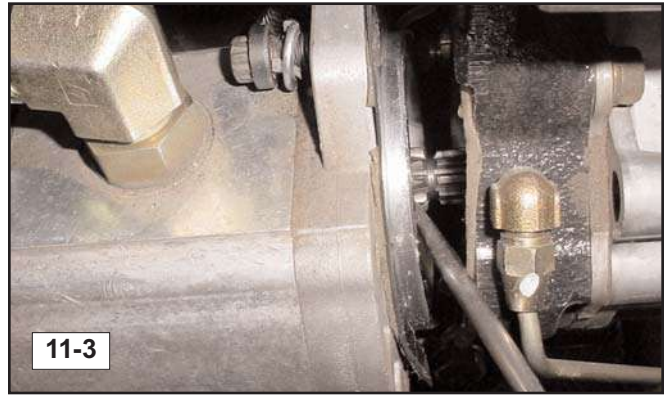

8. Remove the charge pump from the engine. (fig. 11-3)

Installation

1. To install the charge pump, reverse the removal procedure.

Note: The front bearing on the charge pump uses engine oil for lubrication. It must be kept extremely clean. Make sure to shield it as well as the opening to the engine from dirt or debris while disassembled.

The gasket that seals the pump to the engine housing should be replaced whenever the charge pump is removed and installed to prevent oil leaks and or dirt/debris from entering the engine during operation.

Auxiliary Pump Removal

Required Tools

Combination Wrench
Socket Wrench & Extension
Pry bar
Allen socket

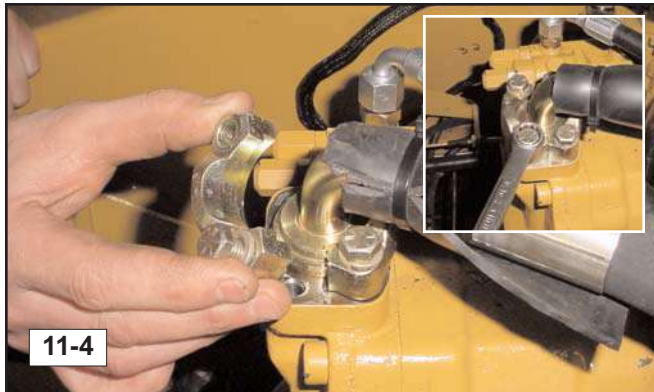

1. Loosen the bolts securing the split flange clamp to the upper front port on the aux. pump. (fig. 11-4)
2. Remove the clamp and lay the hose aside.

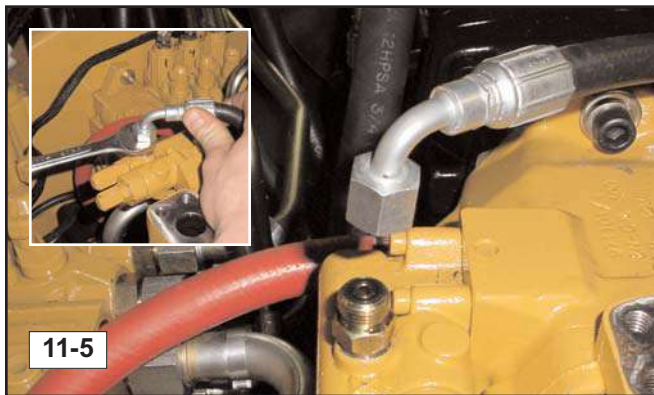

3. Disconnect the hose connected to the relief valve assembly and lay it aside. (fig. 11-5)

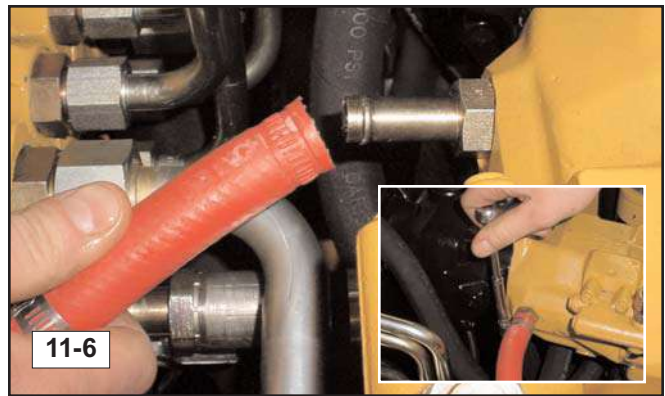

4. Loosen the clamp securing the hose onto the barbed fitting on the right side of the pump, then disconnect it. (fig. 11-6)

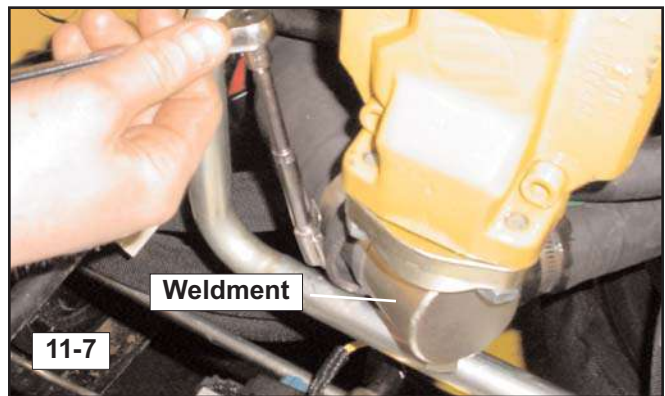

5. Loosen the clamps securing the hoses to the inlet weldment attached to the bottom of the pump. (fig. 11-7)

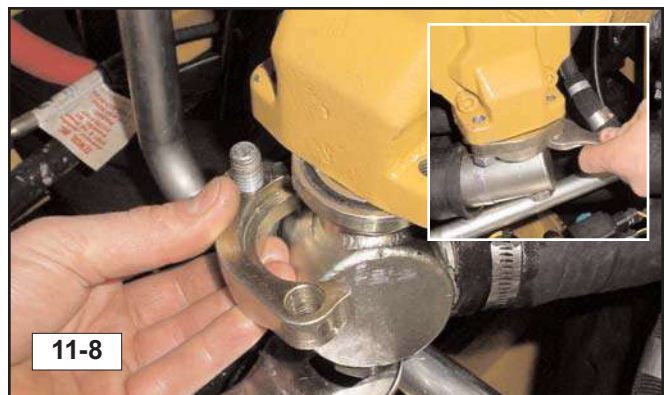

6. Loosen and remove the split flange clamp securing the inlet weldment to the bottom of the pump similarly to the one previously removed on the top of the pump. (fig. 11-8)



11-9

7. Use a pry-bar to pry the inlet weldment out of the hoses. (This can be difficult, lubricating the inlet tubes with a penetrating lubricant may make removal easier.) (fig. 11-9)



11-10

8. Remove the upper and lower pump mounting bolts with an allen socket and extension. You may need to separate the pumps slightly to remove the bolts completely. (fig. 11-10)

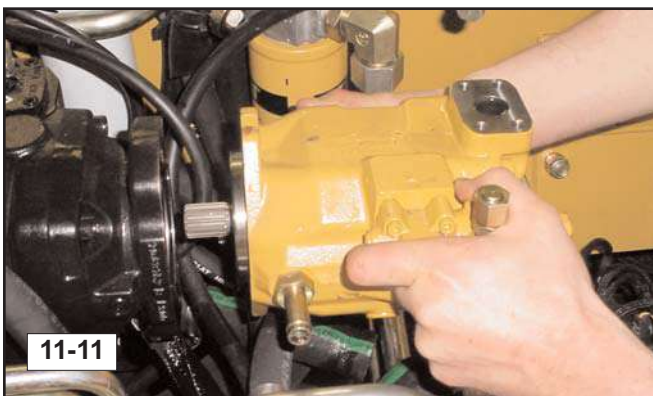

11-11

9. Carefully remove the pump from the machine. (fig. 11-11)

Installation

1. To install the auxiliary pump, reverse the removal procedure.

Tandem (Drive) Pump Removal

Required Tools

Screwdriver

Combination/Open End Wrenches

!WARNING!

Personal injury can result from exposure to hot fluids and components. Allow the machine to cool thoroughly before attempting any type of service on the cooling or hydraulic systems.

NOTICE

Collect and contain liquids in a suitable container. Dispose of all fluids according to local regulations and mandates.

NOTICE

During disassembly, plug and cap hoses and fittings to prevent fluid loss and or contamination.

1. Perform the auxiliary pump removal procedure on page 11-3 of this manual.



11-12

2. Label and disconnect all hoses from the tandem drive pump. (fig. 11-12, 11-13, 11-14, 11-15)

Note: You may need to remove the pump mounting bolts and twist the pump to access and disconnect some of the hoses connected to the drive pump.

Note: Use figures 11-13, 11-14, and 11-15 to aid in hose removal and installation and identification.

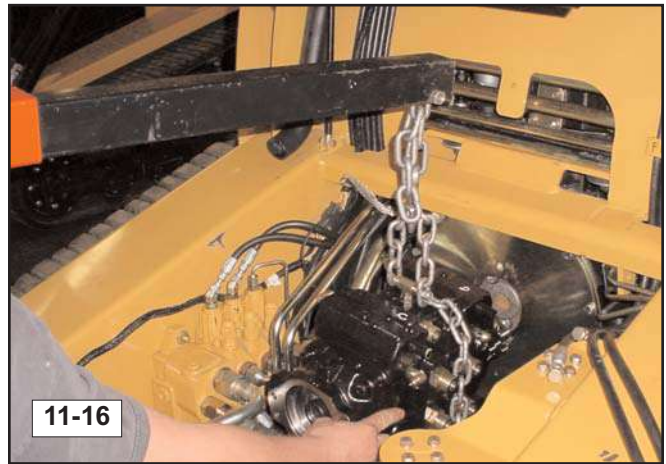
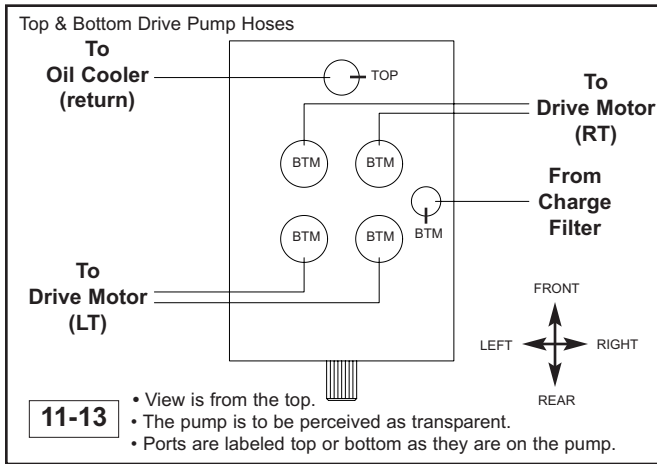

- Support the pump with a hoist or floor jack to prevent it from falling as the mounting bolts are removed. (fig. 11-16)

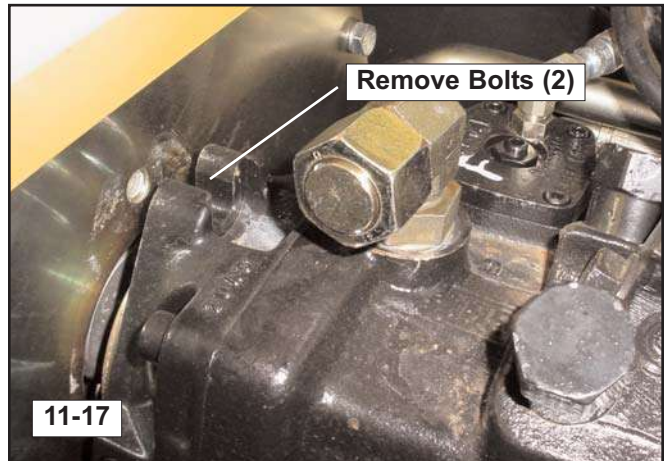
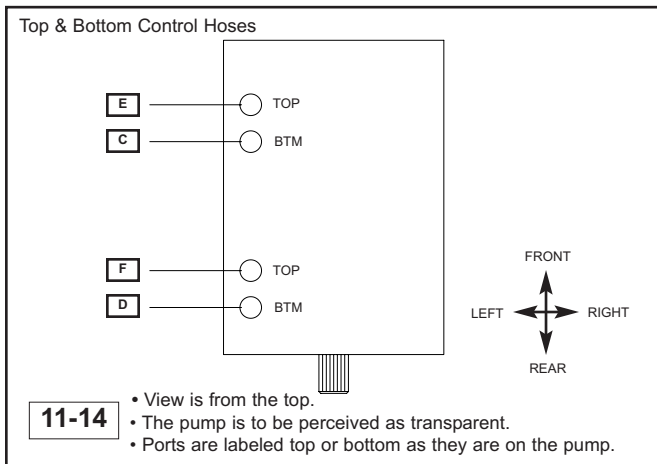

- Remove the upper and lower mounting bolts from the drive pump. (fig. 11-17)

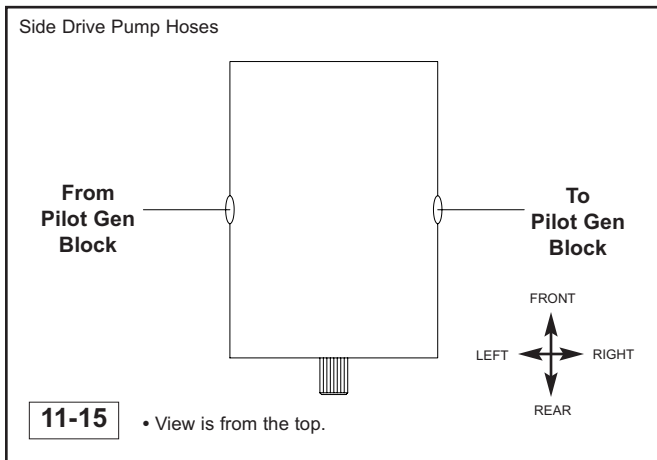

- Remove the drive pump from the machine.

Installation

- To install the drive pump, reverse the removal procedure.

Note: Torque the tandem pump mounting bolts to 85 lb. ft. and use blue *Loc-tite* or equivalent to secure the bolts in position.

Drive Motor Removal

Required Tools
Combination/Socket Wrench
Impact Wrench
3-Jaw Puller
Snap Ring Pliers
Hammer/Mallet

1. Remove the track from the undercarriage by performing the track removal procedure on page 4-6 of this manual.

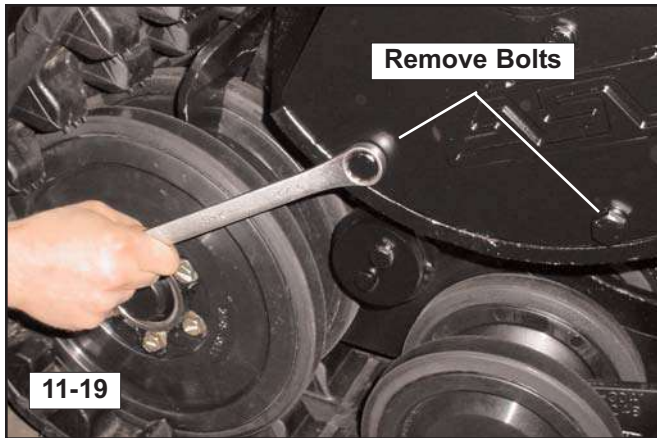

2. Remove the three bolts securing the outer bearing support plate to the drive table. (fig. 11-19)



3. Remove the four bolts securing the outer bearing support plate to the bearing assembly. (fig. 11-20)



4. Remove the bearing support plate from the undercarriage. (fig. 11-21)



5. Use a hammer to tap around the circumference of the bearing cap which releases the outward pressure holding it in place. (fig. 11-22)



6. Remove the bearing cap from the assembly. (fig. 11-23)



7. Remove the snap ring securing the bearing assembly to the outer sprocket shaft. (fig. 11-24)



10. Remove the sprocket assembly from the undercarriage. (fig. 11-27)



8. Use a jaw style puller and an impact wrench to remove the bearing assembly from the sprocket shaft. (fig. 11-25)



11. Remove the bolts securing the drive motor to the drive table. (fig. 11-28)



9. Remove the bolts securing the sprocket to the drive motor. (fig. 11-26)

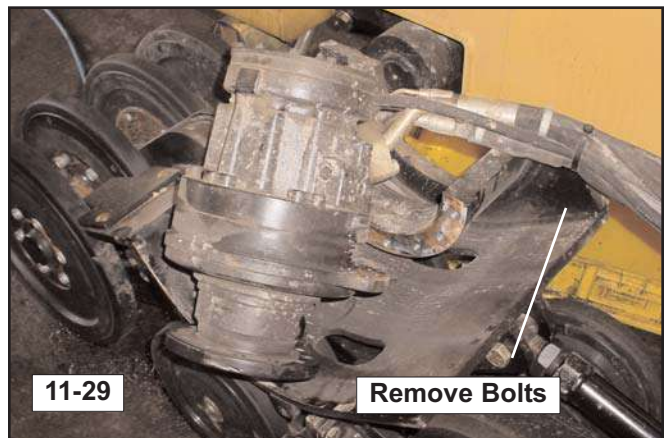

12. Lift the drive motor straight upward until it clears the drive table, then forward to expose the hydraulic hoses for removal. (fig. 11-29)

Note: There are two large bolts near the front of the drive motor support securing it to the lower drive table from the inside (near the chassis). Remove these bolts prior to lifting the motor to provide additional clearance for the hoses as you lift the motor upward. (fig. 11-29)



13. Note the orientation of the hoses as they are connected to the drive motor. Label them to ensure correct installation and proper orientation during reassembly. (fig. 11-30)

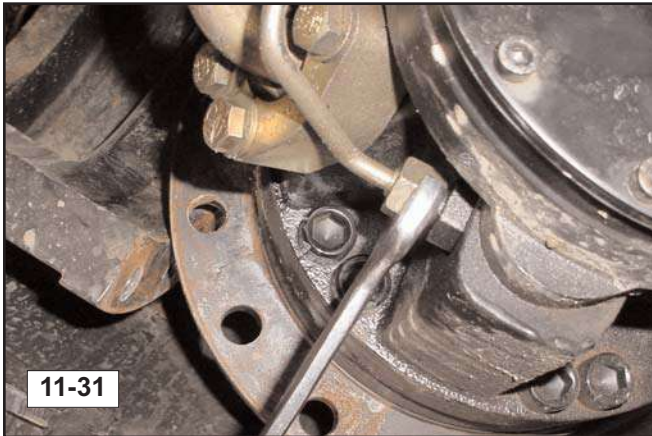

14. Disconnect the hoses from the drive motor making sure to cap and plug all openings to avoid contamination. Remove the drive motor from the undercarriage. (fig. 11-31)

Installation

1. To install the drive motor into the undercarriage, reverse the removal procedure.

Note: During the removal of the bearing cap, the bulged or domed area is beaten inward. When reinstalling the cap, flip it around so that the domed area is toward the outside of the machine. Then tap the center of the cap with a ball peen hammer or similar device to reset the cap. Do this gently, too much force can damage (mushroom) the bearing shaft.

12. Engine

Chapter Overview

This chapter provides procedures for the removal and installation of the engine and associated components.

Personal Safety

!WARNING!

Improper or incomplete maintenance/repair of a Rubber Track Loader can be dangerous and may result in machine damage, injury or even death.

Do not attempt to perform any type of repair or maintenance on a Rubber Track Loader until you have read and fully understood the information in this manual.

Refer to the Operation and Maintenance manual for instructions regarding proper machine operation techniques before operating any Rubber Track Loader.

Prior to performing any type of service work on a Rubber Track Loader, read and understand Chapter 1 (Product Safety) for personal safety information.

Removal and Installation

Removal and installation procedures are provided for the following engine related components.

- Battery
- Exhaust
- Air Cleaner
- Engine

Note: Procedures are provided for only those engine associated components listed above. However, exploded parts diagrams exist in the SR-70 and SR-80 parts manuals to serve as visual aids in the assembly and disassembly of other system components.

Battery Removal

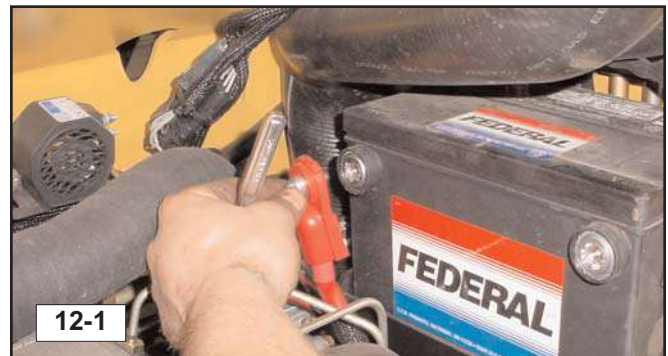

1. Open the hood at the rear of the machine.
2. Disconnect the negative and positive battery cables from the battery terminals. (fig. 12-1)



3. Remove the wingnuts securing the battery hold down strap. (fig. 12-2)

12. Engine



12-3

- Remove the two tension (L) rods by twisting and maneuvering them out of the chassis mounting holes. (fig. 12-3)

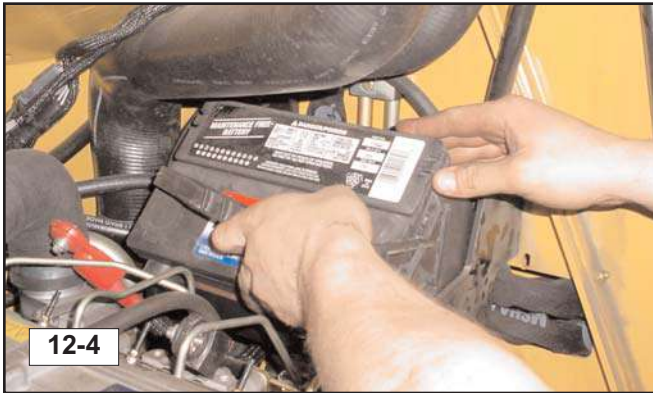

12-4

- Lift and remove the battery from the battery tray. (fig. 12-4)



12-5

- If necessary, remove the battery tray by sliding it upwards and then pulling it away from the chassis. (fig. 12-5)

Installation

- To install the battery, reverse the removal procedure.

Exhaust System

Removal

Required Tools
Pry Bar(s)
Combination/Socket Wrench
Rubber Mallet
Penetrating Lubricant

!WARNING!

The exhaust system is very hot at operating temperature. Make sure the machine is off and cool before attempting to service the exhaust system.

- Perform the radiator/oil cooler removal procedure on page 8-3 to provide access to the exhaust system components.



12-6

- Remove the bolts securing the rear belly pan and remove it from the machine. (fig. 12-6)



12-7

- Remove the nuts securing the head-pipe to the turbo, then pull it away from the studs. (fig. 12-7)

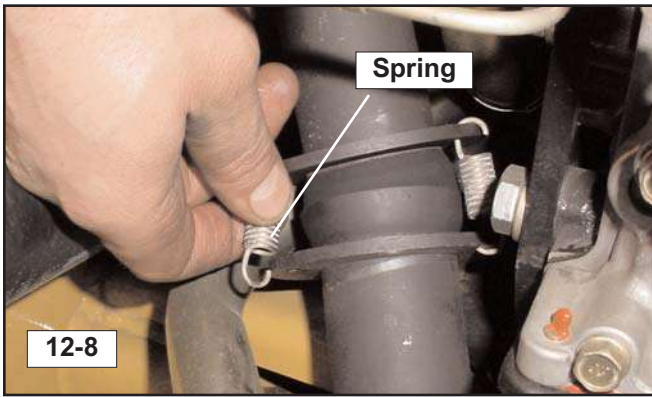

4. Remove the tension springs that secure the middle pipe section to the head (upper) pipe and muffler inlet (lower) pipe. (fig. 12-8)



7. Remove the inlet pipe from the muffler. It may be necessary to use levers to force the inlet pipe section out of the muffler. (fig. 12-11)



5. Remove the upper and middle pipe sections from the machine. (fig. 12-9)

Note: Use caution not to damage the pipe or connection point during removal.

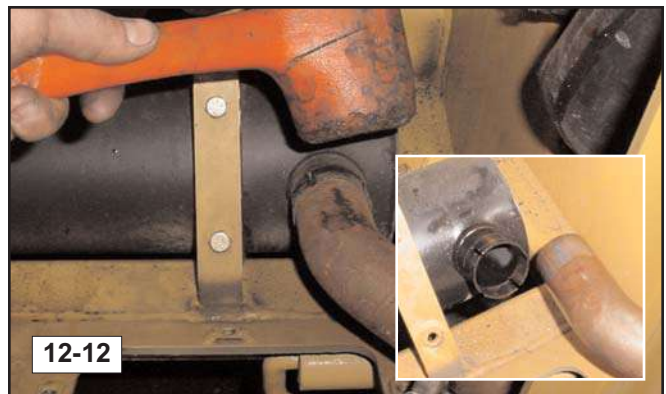

8. Remove the tail pipes from the muffler. If necessary, tap the pipes lightly with a rubber mallet or dead blow hammer to loosen the joints. (fig. 12-12)

Note: Use caution when striking the pipes with a mallet. The pipes are easily damaged and may be disfigured by the blows.

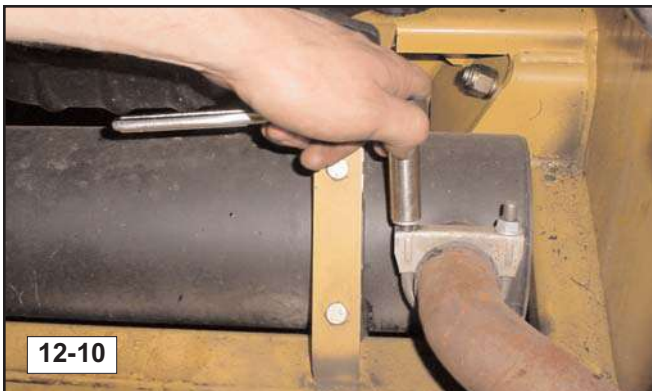

6. Remove the clamps that secure the inlet and outlet pipes to the muffler. (fig. 12-10)

Note: Thoroughly coat all clamped exhaust pipe joints with a penetrating lubricant prior to attempting to remove the pipe sections from the muffler. This will make removal significantly easier.



9. Remove the four bolts (and nuts) securing the muffler to the chassis, then remove the muffler. (fig. 12-13).

12. Engine



10. You may now remove the tail pipes by sliding them forward within the chassis, then out. (fig. 12-14).

Installation

1. To install the exhaust system, reverse the removal procedure.

Air Cleaner

Removal

Required Tools

- Combination Wrenches
- Socket Wrench & Extension

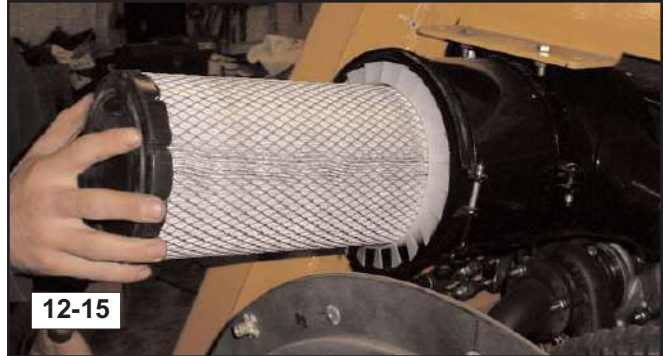

1. Remove the cover and the filter elements from the air cleaner assembly. (fig. 12-15)



2. Loosen the clamp securing the intake hose to the air cleaner housing. (fig. 12-16)



3. Remove the bolts and nuts securing the air cleaner housing to the chassis. (fig. 12-17)



4. Remove the air cleaner housing from the machine. (fig. 12-18)

Installation

1. To install the air cleaner assembly, reverse the removal procedure.

Engine

Removal

Required Tools

Combination/Socket Wrenches Angle Iron or Similar (approx. 43" long) Tie Down or Ratchet Strap Forklift/Engine Hoist Pry Bar

1. Perform the battery, air cleaner, and charge pump, removal procedures in sections 11 and 12 of this manual prior to starting this procedure.
2. Remove the hood assembly as described on page 7-5 of this manual.
3. Raise and support the operator enclosure (cab) as described on page 4-2 of this manual.
4. Perform steps 2-7 of the exhaust removal procedure on page 12-2 of this manual.
5. Remove the center belly pan from the machine.

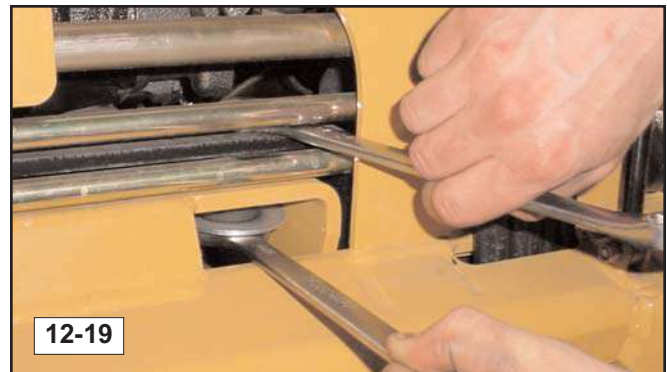

6. Remove the front motor mount bolts (2) from the machine. (fig. 12-19)



7. Remove the rear motor mount bolts (2) from the machine. (fig. 12-20)

12. Engine

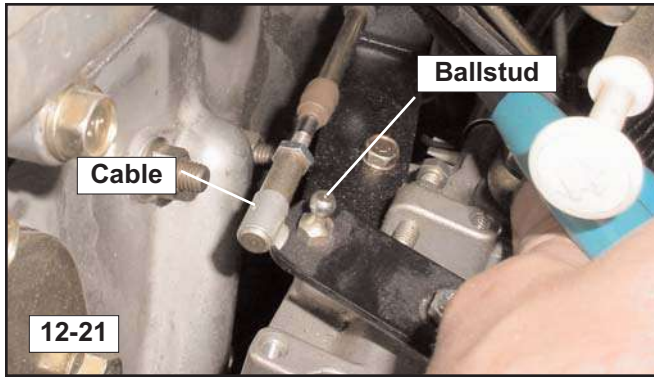

8. Disconnect the throttle cable from the engine.

Note: Once loose, you may want to pull the throttle cable forward through the chassis to make sure it is clear of the engine during removal.

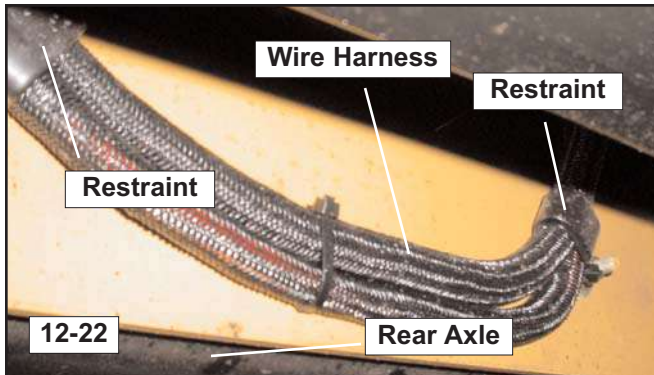

9. Disconnect the cable restraints holding the wire harness to the lower chassis crossmember. (fig. 12-22)



10. Disconnect the wire harness connections in the upper right hand portion of the engine compartment. (when viewed from the rear) (fig. 12-23)

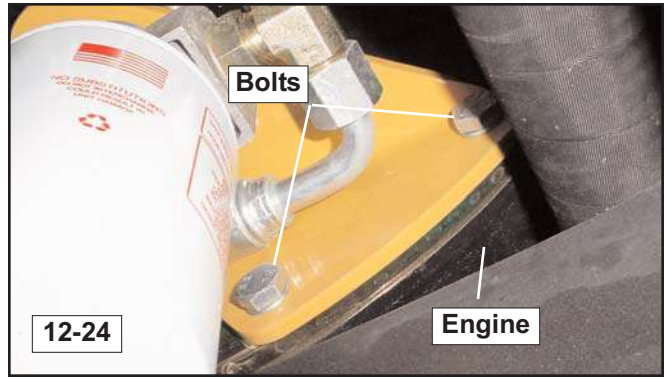

11. Disconnect the case drain filter and bracket from the engine adapter plate and lay it aside. It is situated beneath the drive pump. (fig. 12-24)

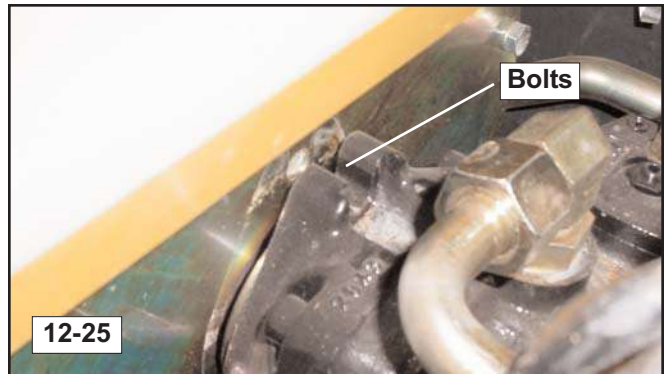

12. Remove the two bolts securing the drive pump to the engine adapter plate. (fig. 12-25)

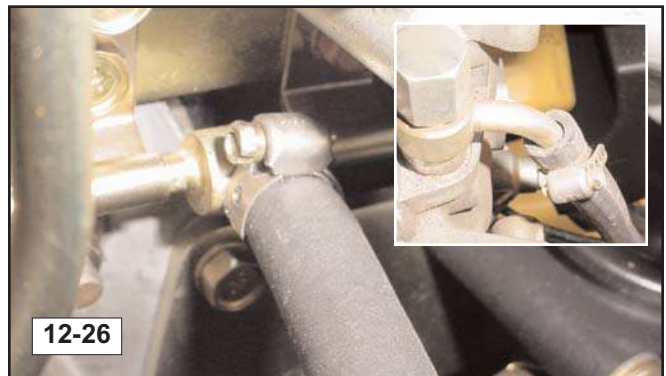

13. Loosen and disconnect the fuel lines (2) from the engine. (fig. 12-26)



14. Lay the angle iron across the fenders (or fuel tank if still in place) and attach one or two tie down straps to serve as a sling to hold the hydraulic pumps up in position during engine removal. (fig. 12-27)



15. Disconnect the ground strap from the upper cross-member. (fig. 12-28)



16. Attach a lifting chain or cable to the lift points on the engine. (fig. 12-29)



17. Attach a device capable of safely lifting the engine to the lifting chain as shown. (fig. 12-30) (see note)



Note: The rear cab window is directly over the lift point of the engine. It is important to use an engine lifting device that is low in profile and can reach forward between the engine and chassis (as shown in fig. 12-30) or the rear window could be damaged. (fig. 12-31)



18. Slide the engine rearward to clear the forward motor mounts, then up and out between the radiator supports. (fig. 12-32)

Installation

1. To install the engine, reverse the removal procedure.

Note: When reinstalling the engine, lightly grease the rubber motor mount surfaces to allow the engine to slide onto them without snagging or disfiguring them.

!WARNING!

Once the engine has been installed, make sure to properly reconnect and install all items removed during engine removal to ensure proper operation.

Prior to starting, make sure all fluids are at appropriate levels and that they have not been contaminated with dirt or debris during service. Change fluids or adjust fluid levels as needed to ensure proper operation.

13. Undercarriage

Chapter Overview

This chapter provides removal and installation procedures for the undercarriages.

Note: For track removal and installation procedures, refer to pages 4-6 through 4-9 of this manual.

Note: For drive sprocket removal and roller inspection and replacement, refer to page 4-5 of this manual.

Personal Safety

!WARNING!

Improper or incomplete maintenance/repair of a Rubber Track Loader can be dangerous and may result in machine damage, injury or even death.

Do not attempt to perform any type of repair or maintenance on a Rubber Track Loader until you have read and fully understood the information in this manual.

Refer to the Operation and Maintenance manual for instructions regarding proper machine operation techniques before operating any Rubber Track Loader.

Machine Preparation

!WARNING!

Accidental machine starting can cause injury or even death to personnel working on a Rubber Track Loader.

As a precaution, disconnect the battery cables from the battery terminals, tape the battery clamps and remove the key from the ignition switch prior to performing any service work on a Rubber Track Loader.

Place a "Do Not Operate" tag prominently on the machine to inform personnel that the machine is being worked on.

Prior to performing any type of service work on a Rubber Track Loader, read and understand Chapter 1 (Product Safety) for personal safety information.

Removal and Installation

Removal and installation procedures are provided for the following undercarriage components.

- Idler Wheels (Removal and installation)
- Bogie Wheels (Removal and installation)
- Hub Assembly Service Procedures

Note: Procedures are provided for only those components listed above. However, exploded parts diagrams exist in the SR-70 and SR-80 parts manuals to serve as visual aids in the removal and installation of other system components.

15" Idler Wheel (SR-80)

Note: The 15" idler and 10" bogie wheels may be removed from the SR-70 and SR-80 undercarriages without removing the tracks.

Removal

Required Tools

Socket/impact wrench Heavy duty hydraulic jack Combination wrench ASV approved jack stands (2) Shop vac or Pressure washer
--

1. Raise and support the machine by following the jacking procedure on page 4-2.

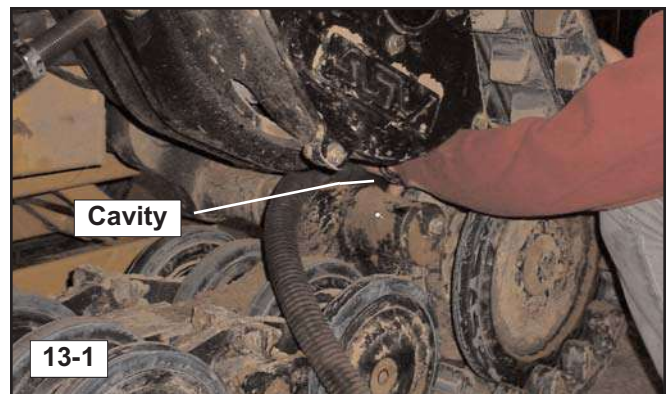

2. Break up and remove any foreign material from the cavity between the suspension rail and the drive table support. (fig. 13-1)

Note: A shop vac or pressure washer will work well to remove material from this cavity.

13. Undercarriage

3. Clean the threads on the turnbuckle thoroughly using a stiff bristle brush.



13-2



13-3

4. Loosen the lock nut on the turnbuckle and spin it to the end of the threaded shaft to allow clearance when the drive table is lowered. (fig. 13-2)
5. Rotate the turnbuckle and lower the drive table as far as it will go. (fig. 13-3)



13-4



13-5

6. Remove the bolts securing the outer wheel to the hub. Then remove the wheel. (fig. 13-4, 13-5)



13-6

7. Remove the outer scraper plate from the suspension rail. (fig. 13-6)



13-7



13-8

8. Remove the bolts securing the inner wheel to the hub, then remove the wheel. (fig. 13-7, 13-8)
9. Repeat this procedure as necessary to remove the 15" idler wheels throughout the undercarriage.

Note: To remove the 10" bogie wheels on the SR-80 undercarriages, refer to page 13-3 of this manual.

Installation

1. To install the 15" idler wheels, reverse the removal procedure. **Torque the wheel mounting bolts upon installation to 90 +/- 10 Lb. Ft.**

10" & 15" Wheels (SR-70)

Note: The 15" idler and 10" bogie wheels may be removed from the SR-70 and SR-80 undercarriages without removing the tracks.

Removal

Required Tools

Socket/impact wrench
Heavy duty hydraulic jack
Combination wrench
ASV approved jack stands (2)
Shop vac or Pressure washer

1. Perform steps 1-5 of the SR-80 15" idler wheel removal procedure on page 13-1.



2. Remove the bolts securing the wheel to the hub. (fig. 13-9)



3. Remove the wheel from the undercarriage. (fig. 13-10)

Note: Steps 2 and 3 are accurate for the removal of both the 10" and 15" wheels throughout the SR-70 undercarriages.

4. Repeat as necessary to remove the idler and bogie wheels throughout the undercarriages.

Installation

1. To install the idler wheels on the SR-70, reverse the removal procedure. **Torque the 15" wheel mounting bolts upon installation to 90 +/- 10 Lb. Ft. Torque the 10" wheel mounting bolts upon installation to 37 +/- 5 Lb. Ft.**

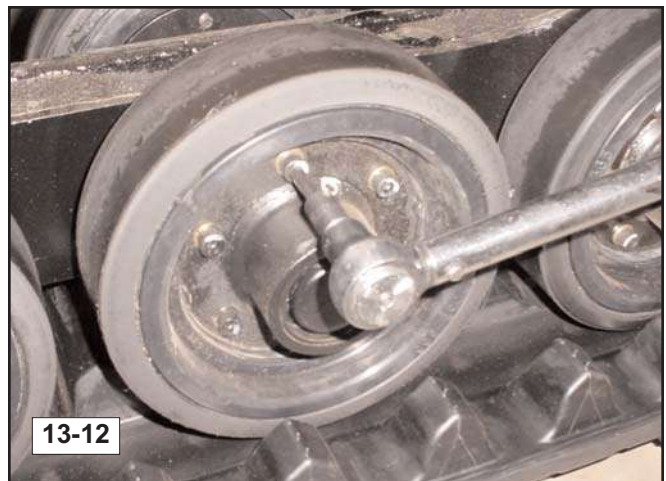

Bogie Wheel (SR-80 only)

Removal & Service Procedure

1. Perform steps 1-5 of the 15" idler wheel removal procedure on page 13-1 to loosen the track and provide clearance for bogie wheel removal.

Required Tools

Combination/Socket Wrenches (including Allen)
Press & Various Press Tooling
Torque Wrench
Bench Vise

13. Undercarriage

Note: Figure 13-36 includes an exploded parts diagram of the SR-80 undercarriage for your reference.



2. Remove the outer plate securing the assemblies to the shaft. (Most plates will be a two bolt design. The one bolt version is shown here.) (fig. 13-13)

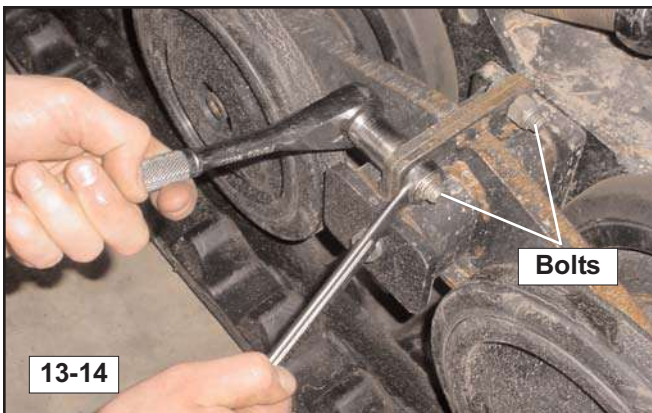

3. Loosen and remove the 4 bolts securing the bogie assemblies together around the mounting shaft. (fig. 13-14, 13-15)

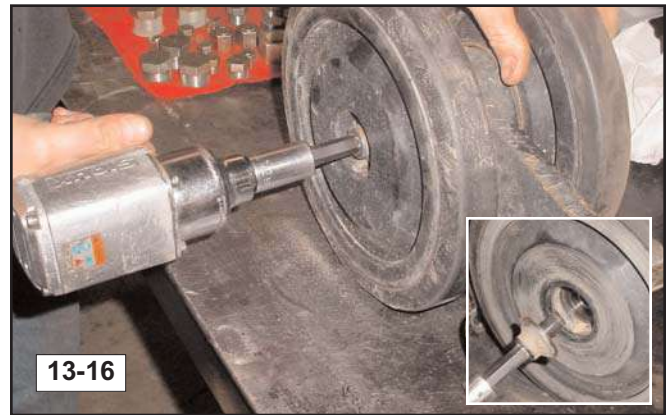

4. The inner and or outer bogie wheels may now be removed with an impact wrench and allen socket as shown in fig. 13-16. If necessary, clamp one wheel in a vise to keep the axle from spinning while you remove the bolts.

Note: The wheel assemblies in the SR machines use metal face seals to keep dirt/debris out of the wheel bearings. During wheel removal/replacement, it is necessary to remove, inspect and clean all components prior to reassembly to ensure proper function.

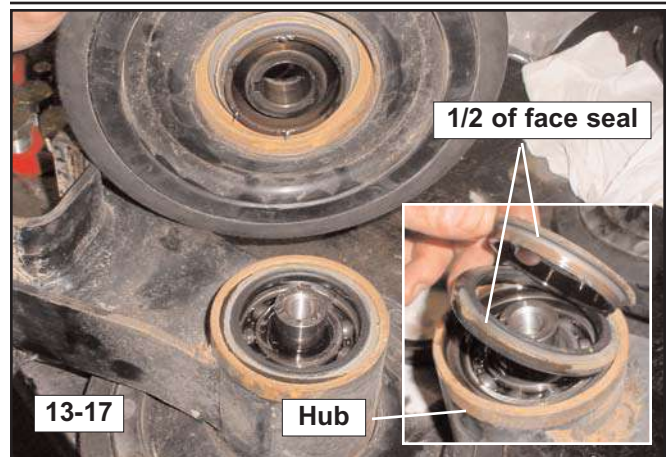

5. Remove both wheels from the hub. (fig. 13-17)

Note: Take care not to drop the metal face seal halves. The sealing surfaces are surface ground and have an extremely fine finish. If scratched or disfigured, the seal will not function as intended.

Also, take care not to lose the keys for indexing the wheels onto the shaft.

Note: Now is a good time to inspect the components for damage or wear. If the bearings do not roll smoothly when rotated, replace them. If the seals appear worn or damaged, replace them. If the wheels are worn or damaged, replace them. If the components appear to be in good working condition, you may reuse them.

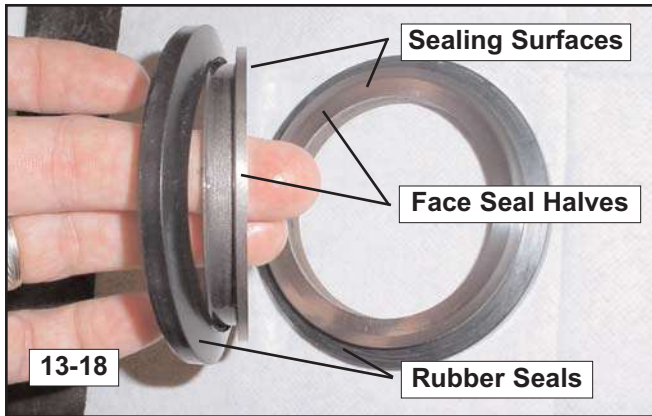

Note: The metal face seals are a 4-piece design with one rubber outer seal and one metal face seal fitted into each wheel and one rubber outer seal and one metal face seal fitted into each hub. As they are assembled, the metal halves mate and ride against each other on a thin layer of oil to seal out dirt and debris. Figure 13-18 shows the various components that make up a face seal. Figure 13-19 shows the seal as a mated assembly.

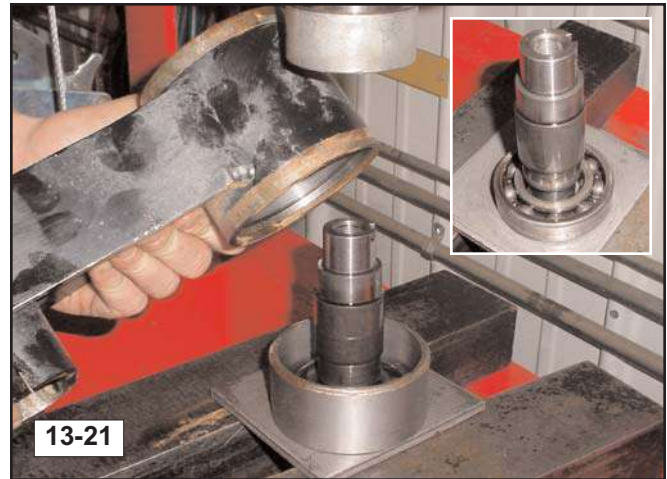

6. Once the wheels have been removed, use a press to push the axle and far side bearing out of the hub as shown. (fig. 13-20, 13-21)
7. If it is necessary to remove the other bearing for replacement, press it out as well. If not, you may leave this bearing in the hub during cleaning.



8. **Clean all parts** (including wheels) **thoroughly** with parts cleaning solution and **dry them** prior to reassembly. Wipe the inner hub surfaces to remove any solvent or oil residue. (fig. 13-22)



9. Reinstall the bearing and shaft into the hub as found upon disassembly, then press the bearing back into the hub over the shaft. (fig. 13-23)

13. Undercarriage

10. Disassemble and clean the face seals and their rubber outer seals thoroughly, then wipe them dry to ensure a good seal when assembled.



13-24

11. Once the seals and hub have been thoroughly cleaned and dried, reinstall the hub portion of the face seal into the hub as shown. Make sure to work the rubber seal down into place within the hub (until it seats) to ensure a good seal. (fig. 13-24)



13-25

12. Similarly, reinstall the wheel portion of the face seal into the (clean) wheel. Make sure to work the rubber seal down into place within the wheel (until it seats) to ensure a good seal. (fig. 13-25)



13-26



13-27A



13-27B

13. Once the seals are in place, wipe the mating surfaces of the face seals with a clean shop cloth and alcohol in a circular motion ending in a gentle sweep from the inside to the outside of the face until clear of the face. This will ensure a clean mating surface and a good seal. (fig. 13-26, 13-27)

14. Apply a **very thin** coating of fresh 10W30 engine oil onto the seal faces (**faces only**) in a circular motion to provide lubrication and help them seal.



13-28

15. Align the wheel hub and axle, then slide the wheel back onto the axle/hub assembly as shown in figure 13-28.



13-29

16. Install the key into the opening in the axle/hub assembly as shown. (fig. 13-29)



17. Apply red (high strength) thread locking compound to the wheel retaining bolt as shown. (fig. 13-30)



18. Install the bolt and tighten it. (fig. 13-31)

19. If you haven't already, repeat steps 10-18 of this procedure on the other side of the hub/wheel assembly to secure the second wheel in place.



20. Once the hub/wheel assembly is together as shown, torque the wheel retaining bolts to 180 ft. lbs. to secure them in place. (fig. 13-32)

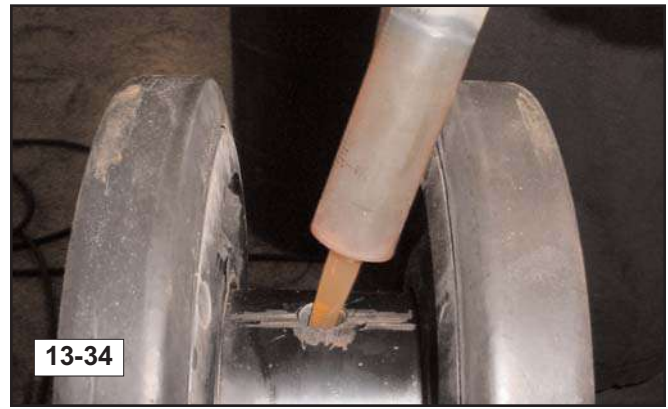

21. Remove the allen plug from the center of the hub assembly and fill it with 2 ounces of ASV Posi Lube™ 10W-30 Heavy Duty Engine Oil. Then reinstall the plug. (fig. 13-33, 13-34)

22. Repeat this procedure on the other half of the bogie assembly if necessary prior to installing the two halves back onto the undercarriage.



23. Place the rubber rods back into position on the square shaft, then tape them in place to keep them secure while installing the bogie assemblies around them. (fig. 13-35)

24. Reverse steps 1-3 of this procedure to reinstall the bogie assembly back onto the undercarriage and complete the procedure.

25. Repeat this procedure as necessary throughout the SR-80 undercarriage to restore proper function.

13. Undercarriage

Note: The hubs on SR-70 & SR-80 machines are very similar in design. The components, although not identical, are serviced in the same manner. Please note any differences between the two machines during disassembly to aid during reassembly. (see notes in procedure)

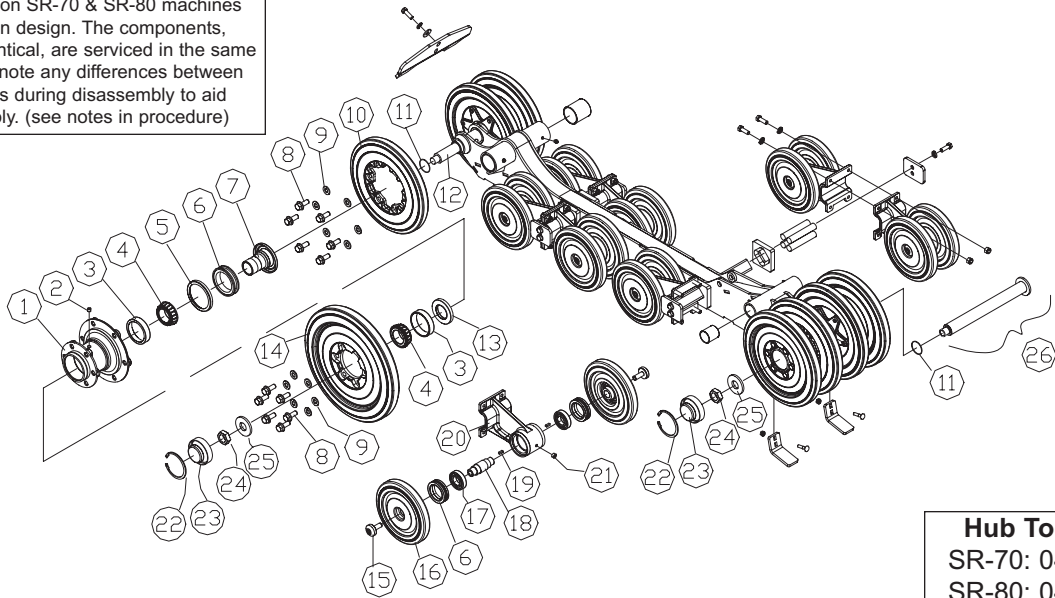

13-36

Hub Tool Kits
 SR-70: 0403-475
 SR-80: 0403-339

Idler Hub

Service Procedure SR-70 & 80 (80 shown)

Required Tools

Socket Wrench & Sockets (including Allen)
Press & Tool Kit (SR-70: 0403-475 or SR-80: 0403-339)
Snap Ring Pliers

1. Remove the hub assemblies from the undercarriages as required first by following steps 1-7 of the track removal procedure on page 4-6. Then proceed to the steps below.
2. Remove the snap ring (item 22) securing the cap (item 23) in the hub assembly. (fig. 13-36)
3. Remove the nut (item 24) and the washer (item 25), then remove the hub assembly from the axle shaft. (fig. 13-36) (see note below)

Note: If you are removing the outer or rear hub assemblies you will be able to remove the hub assembly once step three is complete.

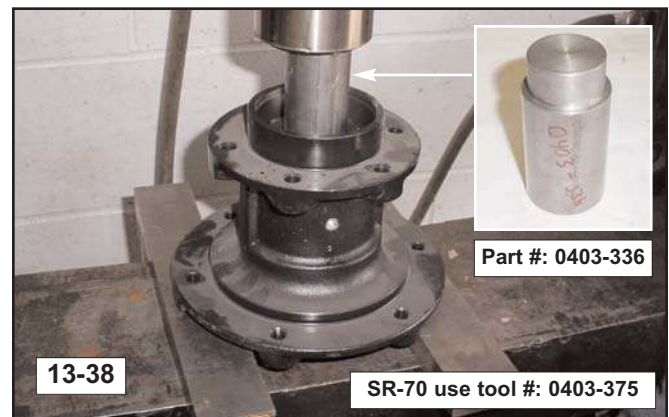
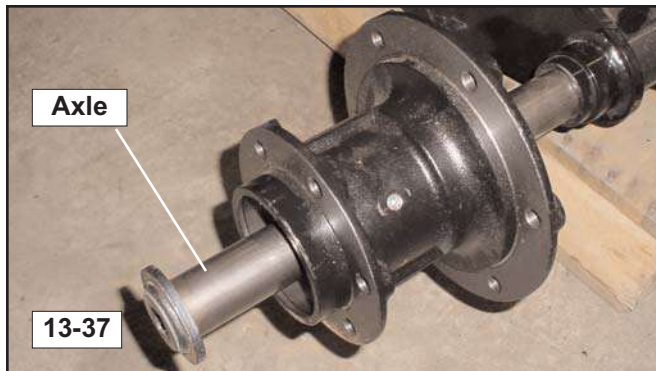

Note: If you are removing the inner front hub assembly, you will have to slide the axle (item 26) out of the main rail weldment to remove it. (fig. 13-36, 13-37)

4. Using a press and tool # 0403-336, press the bearing sleeve out of the hub assembly. (fig. 13-38, 13-39)



13-40

- Remove the bearing out of the front of the hub as shown. (fig. 13-40)

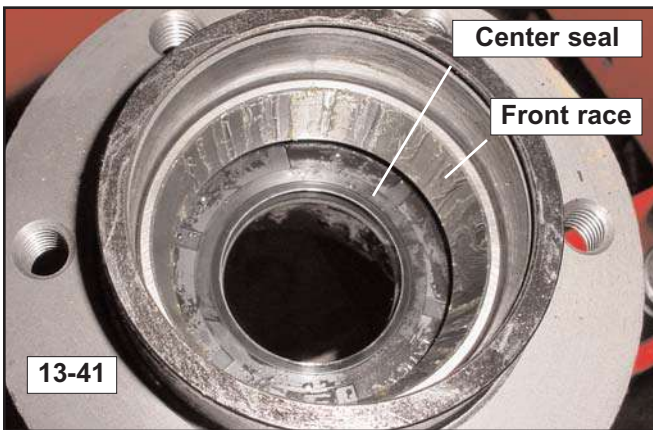

13-41



13-42

SR-70 use tools #: 0403-372 & 0403-375

- Press the center seal and front bearing race out of the assembly from the rear of the hub using tools 0403-337 and 0403-334. (fig. 13-41, 13-42)

Note: The center seal will be destroyed during removal and must be replaced upon reassembly.

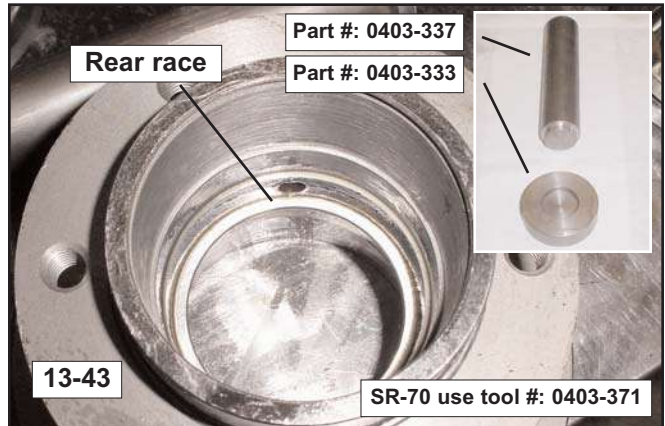

13-43

SR-70 use tool #: 0403-371

- If bearings are to be replaced, press the rear bearing race out of the assembly from the front of the hub with tools 0403-337 and 0403-333. (fig. 13-43)

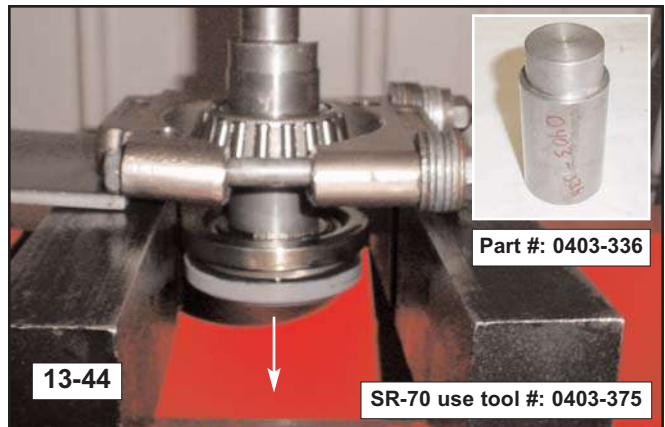

13-44

SR-70 use tool #: 0403-375

- Press the bearing sleeve out of the rear bearing using tool 0403-336. (fig. 13-44)



13-45

- Remove the face seals and retaining ring from the bearing sleeve for cleaning and or replacement. (fig. 13-45)

Note: There is no retaining ring on SR-70 machines.

13. Undercarriage

Note: Take care not to drop the metal face seal halves. The sealing surfaces are surface ground and have an extremely fine finish. If scratched or disfigured, the seal will not function as intended.

Note: Now is a good time to inspect the components for damage or wear. If the bearings do not roll smoothly when rotated, replace them. If the seals appear worn or damaged, replace them. If the wheels are worn or damaged, replace them. If the components appear to be in good working condition, you may reuse them.

10. Thoroughly clean all parts with parts cleaning solution and gently blow them clean with air if necessary, then wipe dry.

11. Disassemble and clean the face seals and their rubber outer seals thoroughly, then wipe them dry to ensure a good seal when assembled.



13-46

12. Once components are clean and dry, install half of the rear face seal into the bearing sleeve. Make sure to work the rubber seal down into place within the seal recess (until it seats) to ensure a good seal. (fig. 13-46)



13-47

13. Install the other half of the rear face seal into the retaining ring. Make sure to work the rubber seal down into place within the ring (until it seats) to ensure a good seal. (fig. 13-47)

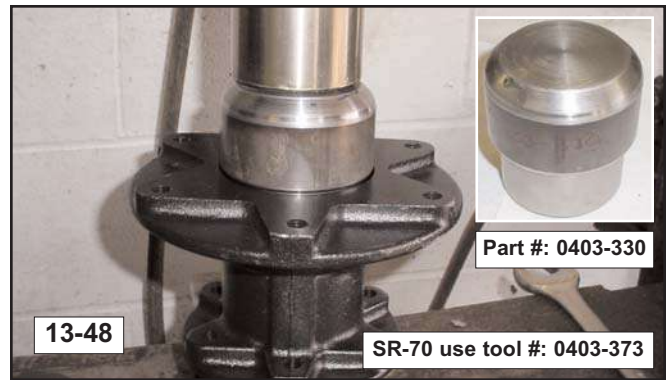

14. If the rear race has been removed, press it into the hub from the rear until properly seated with tool #: 0403-330, then install the clean, dry bearing. (fig. 13-48)

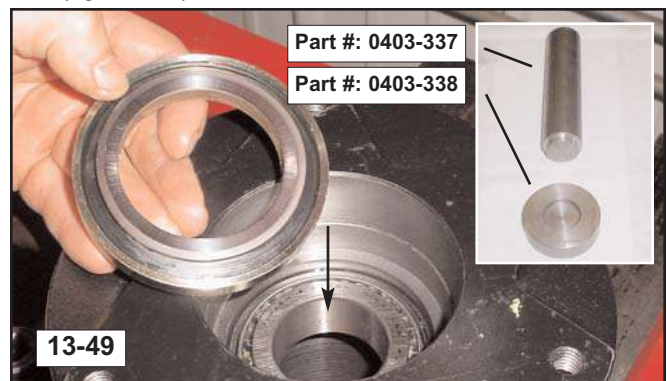

13-50

15. Install the seal/retaining ring assembly into the rear of the hub and press into place until seated using the tools shown above. (fig. 13-49, 13-50)

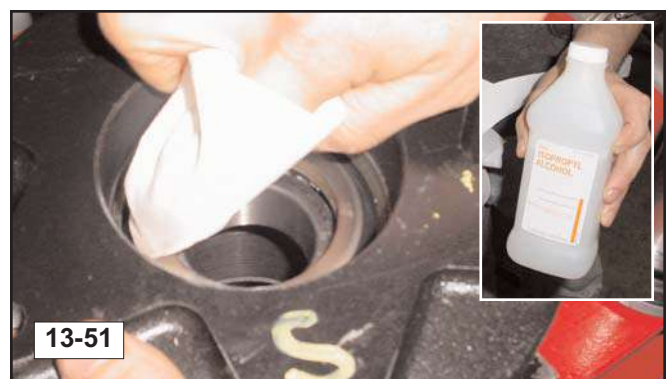

13-51



16. Once the seals are in place, wipe the mating surfaces of the face seals with a clean shop cloth and alcohol in a circular motion ending in a gentle sweep from the inside to the outside of the face until clear of the face. This will ensure a clean mating surface and a good seal. (fig. 13-51, 13-52)



17. Apply a **very thin** coating of fresh 10W30 engine oil onto the now clean seal faces (faces only) in a circular motion. (fig. 13-53)



18. Press the bearing sleeve assembly (with face seal clean, installed, and oiled) into the hub with tool 0403-336 until seated. (fig. 13-54)

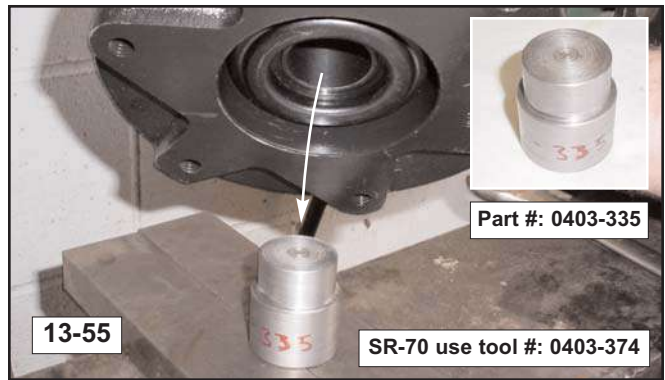

19. Flip the hub over, support the bearing sleeve from the bottom with tool 0403-335 and set it onto the press for center seal installation. (fig. 13-55)



20. Install the center seal into the hub. Work the lip around the bearing sleeve with your fingers prior to pressing it into place. (fig. 13-56)



21. Install the race into the hub as shown above the seal. When the race is pressed into place, it will push the seal into position. (fig. 13-57)

Note: See step 22 for tool information and race installation instructions.

13. Undercarriage



22. Press the outer bearing race into the hub with tool # 0403-330 until it seats. (fig. 13-58)



26. Remove the allen plug in the center portion of the hub. (fig. 13-61)

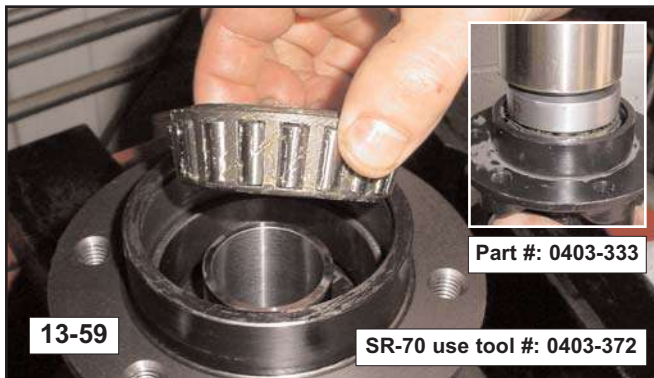

23. Pack the bearing with Posi-Lube Multi-Purpose EP Lithium Grease and then install it onto the bearing sleeve using tool 0403-333. (fig. 13-59)

24. Press it into the assembly until it gently seats into the bearing race. (fig. 13-59)



27. Add 2 oz. (1 oz. SR-70) of Posi-Lube 10W-30 Heavy Duty Engine Oil to the hub as shown, then reinstall the plug and tighten. (fig. 13-62)



25. If necessary, use a needle dispenser to fill any places in the bearing that are not full of grease to ensure adequate lubrication. (fig. 13-60)



28. The hub assembly is now ready to be reinstalled. To install it onto the machine, reverse steps 1-3 on page 13-8 of this procedure. Make sure to read the note below step 3 prior to reinstalling. (fig. 13-63)

29. Repeat this procedure throughout the undercarriage as necessary to repair worn or damaged components and restore proper function.

14. Lift-Arm Components

Chapter Overview

This chapter provides removal and installation procedures for the lift-arm components.

Personal Safety

!WARNING!

Improper or incomplete maintenance/repair of a Rubber Track Loader can be dangerous and may result in machine damage, injury or even death.

Do not attempt to perform any type of repair or maintenance on a Rubber Track Loader until you have read and fully understood the information in this manual.

Refer to the Operation and Maintenance manual for instructions regarding proper machine operation techniques before operating any Rubber Track Loader.

Machine Preparation

!WARNING!

Accidental machine starting can cause injury or even death to personnel working on a Rubber Track Loader.

As a precaution, disconnect the battery cables from the battery terminals, tape the battery clamps and remove the key from the ignition switch prior to performing any service work on a Rubber Track Loader.

Place a "Do Not Operate" tag prominently on the machine to inform personnel that the machine is being worked on.

Prior to performing any type of service work on a Rubber Track Loader, read and understand Chapter 1 (Product Safety) for personal safety information.

NOTICE

The hydraulic system fluid should be changed following any hydraulic component service according to the procedure described on page 4-16.

Removal and Installation

Removal and installation procedures are provided for the following lift-arm components.

- Lift Cylinder
- Bucket/Tilt Cylinder
- Quick Coupler Block PRV

Note: Procedures are provided for only those lift-arm components listed above. However, exploded parts diagrams exist in the SR-70 and SR-80 Parts manuals to serve as visual aids in the assembly and disassembly of other system components.

Note: Refer to page 3-1 through 3-3 for pictorial views of the hydraulic systems and components.

Lift Cylinder Removal

Required Tools

Combination/Open End/Socket Wrenches
Hydraulic Caps/Plugs (various sizes)
ASV Approved Jack Stand (or equivalent)
Pin Removal Tool (ASV P/N: 2045-277)

NOTICE

Cap and plug all fittings and hoses to prevent fluid loss and or contamination during service work.

!WARNING!

Remove any attachment, lower or safely support the lift arms and make sure the hydraulic oil is cool before removing any components or lines. Hot or pressurized oil can cause personal injury.

Rubber Track Loader
14. Lift-Arm Components



1. Rest the lift arms on an ASV approved jack stand to provide clearance for lift cylinder removal. (fig. 14-1)



2. Disconnect the inlet and outlet hoses from the cylinder. (fig. 14-2)

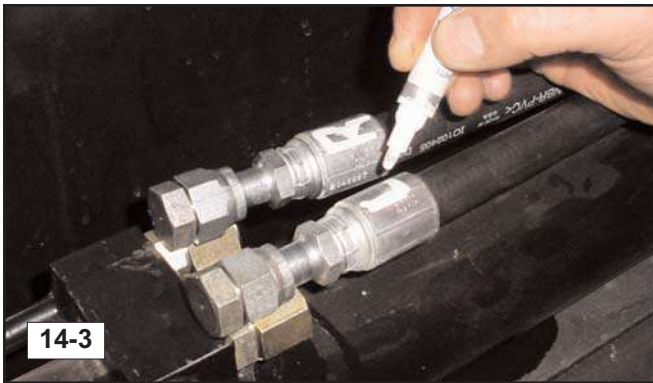

3. Label the hoses according to right and left orientation to simplify reassembly, then cap and plug the hoses and fittings to prevent fluid loss and or system contamination. (fig. 14-3)



4. Remove the bolts securing the front and rear lift arm cylinder pivot pins to the lift arm and lift arm tower. (fig. 14-4)



5. Remove the grease fitting from the pivot pins to allow the installation of the pin removal tool. (fig. 14-5)



6. Thread the removal tool into each pin, then use the slide hammer to extract them. (fig. 14-6)



7. Remove the cylinder from the machine for service or inspection. (fig. 14-7)

Note: At this time the pivot bushings and pivot pins are easily accessible for replacement. Inspect them for visible wear or damage and replace them as necessary .

Installation

1. To install the lift arm cylinder, reverse the removal procedure.

Bucket/Tilt Cylinder Removal

Required Tools

Socket Wrench
Combination/Open End Wrench
Hammer
Punch (brass)



1. Raise the lift arms and support them with the lift arm brace as described on page 4-1. (fig. 14-8)



2. Place a suitable catch container beneath the cylinder fittings, then disconnect the inlet and outlet hoses from the cylinders. (fig. 14-9)
3. Cap and plug the hoses and fittings to prevent fluid loss and or system contamination.

Rubber Track Loader
14. Lift-Arm Components



4. Remove the bolt securing the lower pin to the quick attach. (fig. 14-10)



7. Use a pry bar to slide the lower pin out of the cylinder end allowing it to be removed. (fig. 14-13)



5. Remove the bolt securing the upper pin to the lift arm weldment. (fig. 14-11)

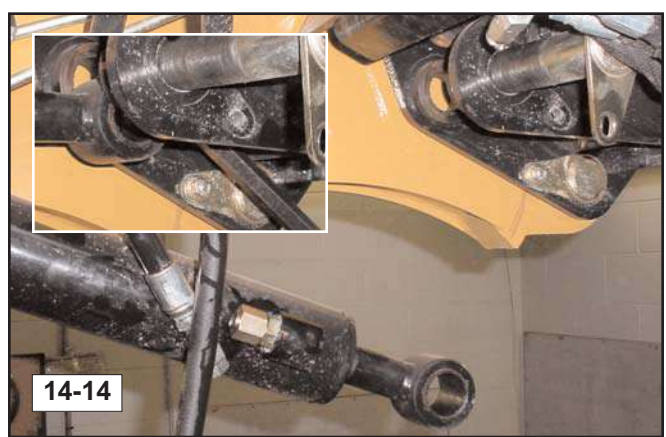

8. Use a pry bar to pry the lower cylinder eyelet out of the upper Q/A mount as shown. (fig. 14-14)

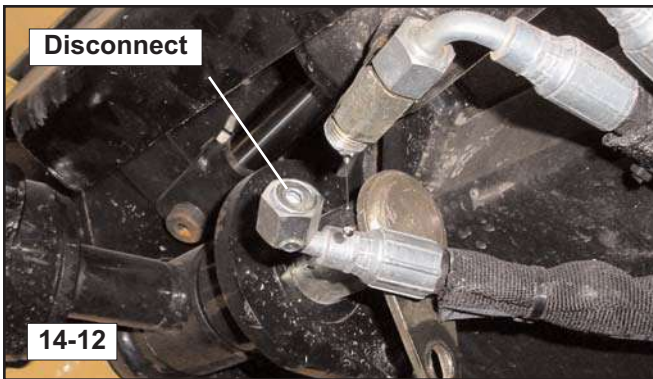

6. Disconnect the outer quick attach cylinder hose (if equipped) to allow the lower pin to be removed. (fig. 14-12)



9. Use a hammer and a brass punch to tap the upper pin most of the way out of the lift arm weldment. (fig. 14-15)

Note: Make sure to support the cylinder (have an assistant support it if necessary) while removing the upper pin to prevent it from falling and being damaged or from causing injury to anyone standing underneath.



10. Remove the pin from the cylinder while supporting the cylinder. (fig. 14-16)



11. Remove the cylinder from the machine. (fig. 14-17)

Installation

1. To install a bucket/tilt cylinder, reverse the removal procedure.

Quick Coupler Block PRV Removal

Required Tools

Combination Wrench



1. With the machine off and cool and with all hydraulic actuators relaxed, loosen the pressure release valve on the top of the auxiliary quick coupler block. (fig. 14-18)



2. Once loose, remove the valve from the block by twisting it counter-clock-wise until free. (fig. 14-19)

Installation

1. To install the Q/C PRV, reverse the removal procedure.

15. Quick Attach

Chapter Overview

This chapter provides removal and installation procedures for the quick attach and associated components.

Personal Safety

!WARNING!

Improper or incomplete maintenance/repair of a Rubber Track Loader can be dangerous and may result in machine damage, injury or even death.

Do not attempt to perform any type of repair or maintenance on a Rubber Track Loader until you have read and fully understood the information in this manual.

Refer to the Operation and Maintenance manual for instructions regarding proper machine operation techniques before operating any Rubber Track Loader.

Machine Preparation

!WARNING!

Accidental machine starting can cause injury or even death to personnel working on a Rubber Track Loader.

As a precaution, disconnect the battery cables from the battery terminals, tape the battery clamps and remove the key from the ignition switch prior to performing any service work on a Rubber Track Loader.

Place a “Do Not Operate” tag prominently on the machine to inform personnel that the machine is being worked on.

Prior to performing any type of service work on a Rubber Track Loader, read and understand Chapter 1 (Product Safety) for personal safety information.

Removal and Installation

Removal and installation procedures are provided for the following quick attach components.

- Quick Attach locking Pin Assemblies
- Quick Attach Pivot Pins

Note: Procedures are provided for only those quick attach components listed above. However, exploded parts diagrams exist in the SR-70 and SR-80 Parts manuals to serve as visual aids in the assembly and disassembly of other system components.

Locking Pin Assembly Removal

Required Tools

Combination/Open End/Socket Wrenches
ASV Approved Jack Stand (or equivalent)

!WARNING!

Remove any attachment, lower or safely support the lift arms and make sure the hydraulic oil is cool before removing any components or lines. Hot or pressurized oil can cause personal injury.



1. Rest the lift arms on an ASV approved jack stand to provide clearance for quick attach disassembly. (fig. 15-1)

15. Quick Attach

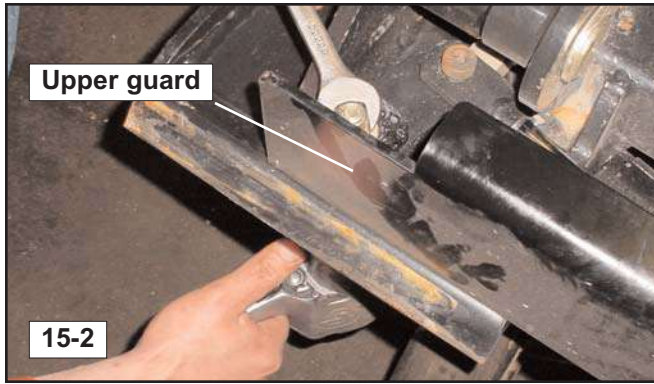

2. Remove the bolts (3) securing the upper guard to the quick attach weldment. (fig. 15-2)



3. Remove the upper guard from the quick attach. (fig. 15-3)



4. Remove the bolt securing the locking pin assembly to the locking cylinder or latch handle. (fig. 15-4)



5. Remove the pivot link from the quick attach. (fig. 15-5)



6. Slide the locking pin assembly out of the quick attach. (fig. 15-6)



Note: At this time the locking pin assembly components are easily accessible for replacement. Inspect them for visible wear or damage and replace them as necessary .

Pay attention to the quantity and position(s) of each component to aid during reassembly. (fig. 15-7)

Installation

1. To install the quick attach locking pin assembly, reverse the removal procedure.

Pivot Pin (quick attach)

Removal

Required Tools
Combination/Open End/Socket Wrenches ASV Approved Jack Stand (or equivalent) Hammer Punch (brass)



1. Rest the lift arms on an ASV approved jack stand to provide clearance for quick attach disassembly. (fig. 15-8)

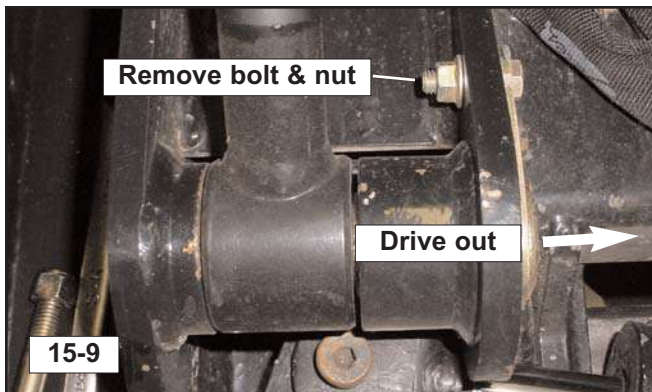

2. Remove the bolt securing the pivot pin to the quick attach weldment, then drive the pin out with a hammer and brass drift punch. (fig. 15-9)

Note: There are four pivot pins that connect the quick attach to the lift arm and cylinders. All four pins are removed in a similar manner.

Installation

1. To install the quick attach pivot pins, reverse the removal procedure.
2. Repeat this process as necessary to remove and replace worn or damaged quick attach pins.

NOTICE

Disassembly of hydraulic components should only be performed by factory trained personnel experienced in the disassembly and repair of hydraulic components. Components should not be serviced during the warranty period without written instruction from the ASV service department. Component disassembly during this period may void the manufacturer's warranty.

Chapter Overview

This chapter provides information on inspection, disassembly and assembly of major hydraulic components.

Personal Safety

!WARNING!

Improper or incomplete maintenance/repair of a Rubber Track Loader can be dangerous and may result in machine damage, injury or even death.

Do not attempt to perform any type of repair or maintenance on a Rubber Track Loader until you have read and fully understood the information in this manual.

Refer to the Operation and Maintenance manual for instructions regarding proper machine operation techniques before operating any Rubber Track Loader.

Prior to performing any type of service work on a Rubber Track Loader, read and understand Chapter 1 (Product Safety) for personal safety information.

!WARNING!

When servicing any hydraulic component, make sure the machine is off and cool and that all of the hydraulic actuators are relaxed prior to disconnecting or removing any component from the system.

NOTICE

When servicing any hydraulic component, keep in mind that any scratches or damage that can be felt with a fingernail on surfaces that parts move, slide, roll or rotate upon indicate a need for part replacement.

Hydraulic components must be kept extremely clean to ensure proper function and service life. Do not assemble any components that have not been inspected for damage and thoroughly cleaned prior to assembly.

The hydraulic system fluid should be changed following any hydraulic component service according to the procedure described on page 4-16.

16. Hydraulic Component Service Procedures

Disassembly & Assembly

Disassembly and assembly procedures are provided for the following components:

- Hydraulic Cylinders
- Lift Arm Control Valve
- Drive motor
- Drive Pump
- Auxiliary Pump

Note: Procedures are provided for only those components listed above. However, exploded parts diagrams exist in the SR-70 & SR-80 parts manuals to serve as visual aids in the assembly and disassembly of other system components.

Hydraulic Cylinder

Disassembly

Required Tools

Bench Vise
Pipe Wrench
Socket or Impact Wrench
Screwdriver (blade type)
Rubber or Dead Blow Hammer
Small Pry Bar

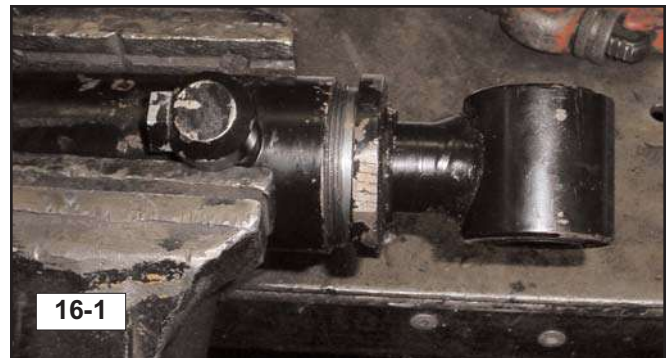

1. With machine off and cool and with hydraulic actuators relaxed, disconnect and cap hoses from the cylinder(s) to be serviced.

Note: When servicing cylinders, the attached components must be supported in a manner that allows the cylinders to be safely removed and installed. (lift arms & quick attach)

2. Remove the cylinder(s) and secure it in a bench vise to aid in disassembly. (figure 16-1)
3. Place a suitable catch container beneath the rod end of the cylinder to catch any hydraulic oil that may leak out upon disassembly.

16. Hydraulic Component Service



4. Use an open end or pipe wrench to turn and remove the end gland. (figure 16-2)

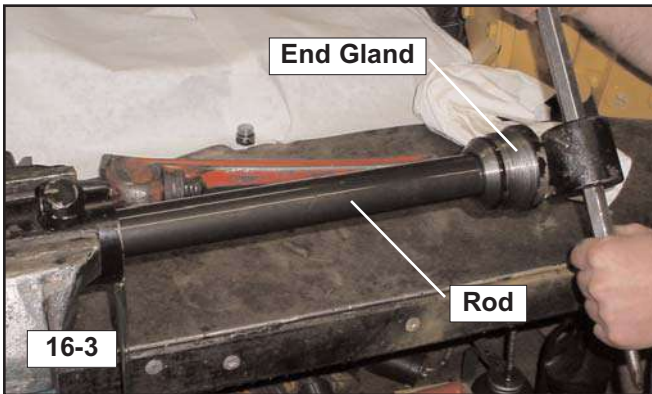

5. Use a pry bar or similar device to pull the rod and piston from the cylinder. (figure 16-3)

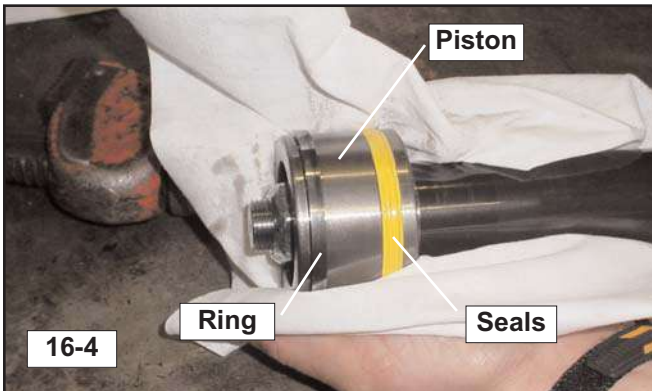

6. Inspect the piston surface, seals and ring for wear or damage. If any component appears to be damaged in any way, replace it. When inspecting the piston surface, look for scratches. If any are present that are deep enough to catch with your fingernail, the piston should be replaced. (figure 16-4)

Note: Seal imperfections or scratches on the piston, bore or rod will cause internal/external leakage and impaired function. Defective components must be repaired or replaced.



7. With the piston and rod removed from the cylinder, inspect the cylinder bore for scratches or other damage. If any are present that are deep enough to catch with your fingernail, the cylinder tube weldment should be replaced. (figure 16-5)



8. Remove the nut from the rod end. (figure 16-6)



9. Support the piston loosely from the underside (figure 16-7), thread the nut partially on to protect the threads and tap the rod end with a rubber or dead blow hammer to free the piston from the rod.

10. Once loose, remove the nut and piston from the rod.



16-8



16-11



16-9

11. Remove the seals and piston ring taking care not to scratch the piston. Also, pay close attention to seal and ring orientation and position to aid when installing new parts. (figures 16-8, 16-9)

13. Remove the tandem seals from the end gland paying close attention to the order of removal to aid during installation of the new seals. (fig. 16-11)



16-12

14. Remove the inner seal from the end gland. Pay attention to the seal orientation upon removal to aid during installation of the new seal. (fig. 16-12)

15. Remove the end gland outer seal from the end gland. (figure 16-10)

16. Thoroughly clean all parts to prevent contamination of hydraulic oil when reinstalled.



16-10

12. Gently tap the end gland off of the cylinder rod. (figure 16-10)

Assembly

1. Install new seals and components in place of the originals paying close attention to orientation and location to ensure proper operation.
2. Lubricate the piston, ring, and seals with fresh hydraulic oil prior to assembly to avoid damage.
3. Reassemble components by reversing the disassembly process.

Note: During reassembly, use an impact wrench to tighten the piston retaining lock nut. Make sure the nut is tight and that there is no independent movement between the piston and rod before reassembling.

Lift Arm Control Valve Disassembly

Required Tools
Socket Wrench Combination Wrench Screwdriver (blade type) Low Profile Needle Nose Pliers

1. With machine off and cool and with hydraulic actuators relaxed, remove the lift arm control valve according to the procedure on page 10-4.
2. Place the valve on a bench in a clean work area.



3. Remove the nuts holding the valve stack together. (figure 16-13, 16-14)



4. Remove each valve section and inspect the seals for damage, replace if necessary. (figure 16-15)



5. Remove the inlet port assemblies and inspect the seals for damage, replace if necessary. (figure 16-16, 16-17)



6. Once the inlet port covers have been removed from both sides of a spool, the spool may be removed. (fig. 16-18)

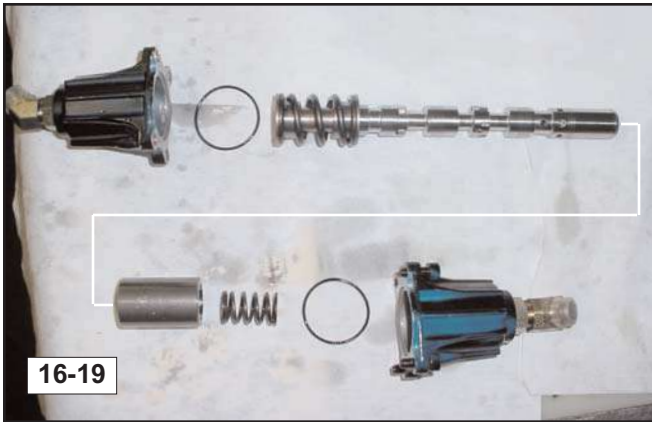

Note: Figure 16-19 displays the assembly order of the spool and associated components.

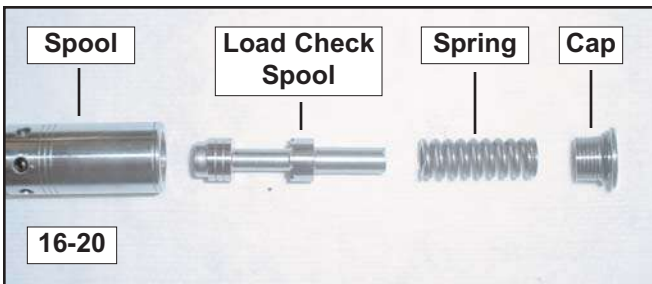

Note: The lift arm and bucket control spools are each equipped with a unique load check spool. The load check spools provide bucket positioning (self-Leveling). The components can be seen above in figure 16-20.

The load check spools are similar, but they are not identical. The main spools are also unique. All spools must be reinstalled as found upon disassembly to function properly.

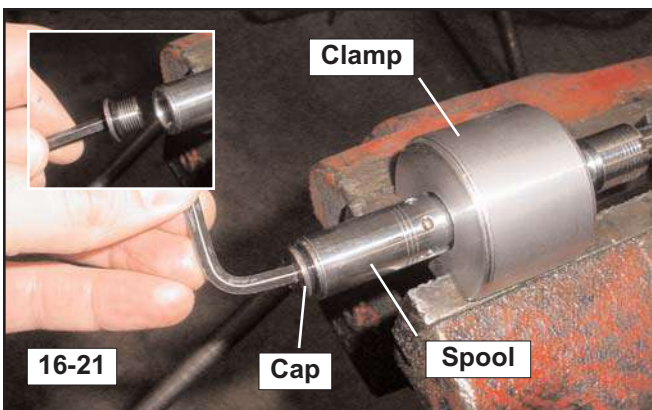

7. To remove the load check spool, use a clamp to hold the spool in place in a vice without damaging the spool and remove the end cap with an allen wrench. (fig. 16-21)



8. Remove the spring from the spool. (fig. 16-22)



9. Remove the load check spool with a low profile needle nose pliers. (fig. 16-23)



Note: There is a passageway in the load check spool that must be kept clear to ensure proper operation. It leads from the small hole in the side of the spool to the end of the spool. If you cannot blow air through this passageway, it must either be cleaned or the load check spool must be replaced to restore proper function. (fig. 16-24)

Assembly

1. Install new seals and components in place of the originals as necessary paying close attention to location and orientation to ensure proper function.
2. Thoroughly clean all components to prevent system contamination.
3. Reassemble components by reversing the disassembly process.

Drive Motor (brake portion)

Disassembly

Required Tools

Allen Wrench/Socket

Rubber Mallet (seal removal if needed)

Screwdriver (blade type) (seal removal if needed)
--

1. With machine off and cool and with hydraulic actuators relaxed, remove the drive motor from the undercarriage by following the procedure in section 13.



2. Remove all but four of the allen bolts (on opposite sides of the cover) holding the rear cover onto the drive motor, then back the remaining four out evenly to release the light spring pressure against the cover. (fig. 16-25)



3. Remove the rear cover to expose the brake assembly. (fig. 16-26)



4. Remove the brake spring and shims. Make sure to note the order of assembly to ensure correct reassembly. (fig. 16-27)



5. Insert an air nozzle into the port closest to the rear of the pump as shown. (fig. 16-28)
6. Cover the opening with a shop cloth and apply moderate pressure to the top of the brake piston to keep it in place when air is applied. (fig. 16-28)
7. Apply air to the port and the piston should slide upwards so that it can be removed.

Note: There is a seal around the outer edge of the piston so it may pop loose rather than gently slide out.



8. Remove the piston from the motor. Inspect the seal for any damage. (fig. 16-29)

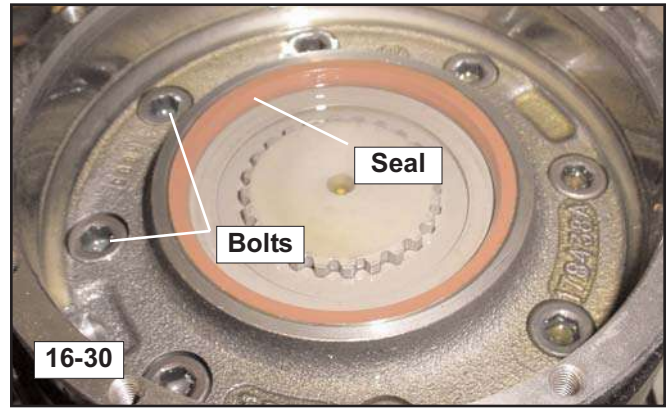

9. Inspect the seal for any damage. (fig. 16-30)

10. Remove the allen bolts securing the upper casting to the drive motor. (fig. 16-30)



11. Remove the upper casting from the drive motor to expose the clutch discs. (fig. 16-31)



12. Inspect the discs for discoloration (blueing) or for signs of excessive wear. (fig. 16-32)

Note: If any of the individual discs measure less than .015" replace them as a set.

Assembly

1. Replace worn or damaged components, thoroughly clean all parts, then reassemble the motor by reversing the disassembly procedure.

Drive Motor (motor portion) Disassembly

Required Tools
Allen Wrench/Socket Snap Ring Pliers Screwdriver (blade type) (seal removal if needed)



1. Mark the casing across the parting lines as shown to ensure correct reassembly of the drive motor. (fig. 16-33)

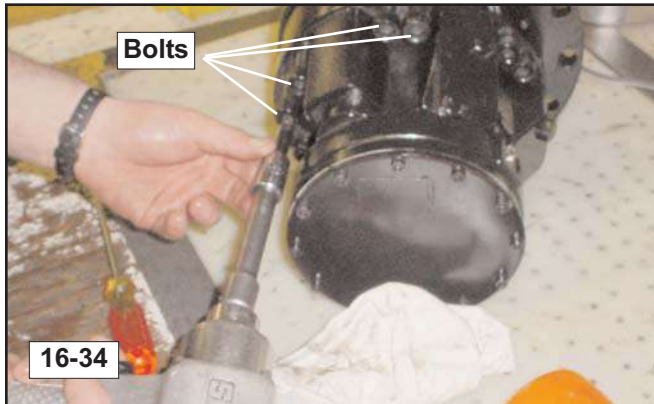

2. Remove the allen bolts securing the output end of the drive motor to the main casting and remove it from the motor as shown. (fig. 16-34, 16-35)

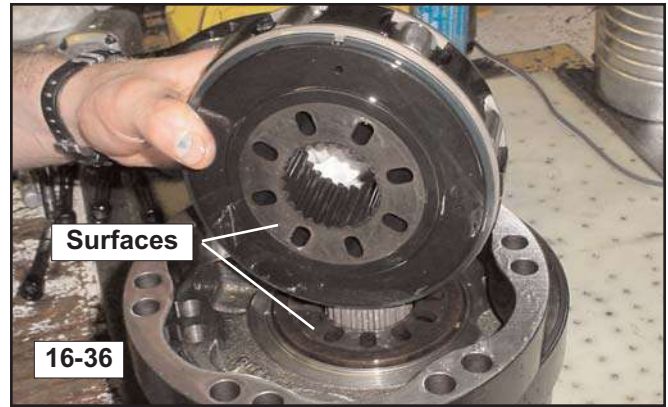

3. Lift and remove the piston block to expose the sealing surfaces. Inspect these surfaces to ensure there is no scratching or abrasion that may affect operation. (fig. 16-36)

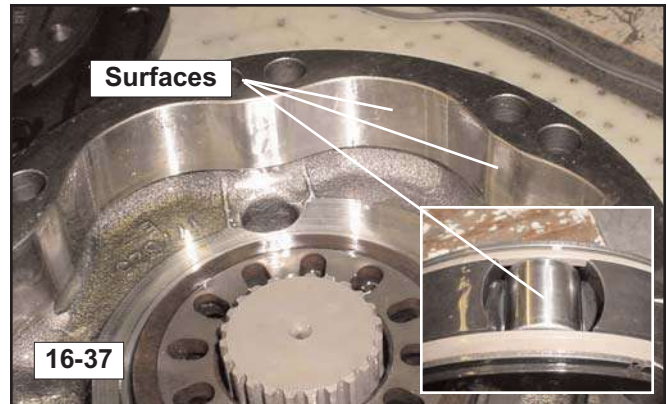

4. Inspect the surfaces of the cam ring and the piston rollers for imperfections. Any damage found indicates a need for component replacement. (fig. 16-37)



5. Using a snap ring pliers, remove the snap and retaining rings on both sides of the piston block to allow for removal and inspection of the block, pistons, piston rings, and rollers. (fig. 16-38)



16-39

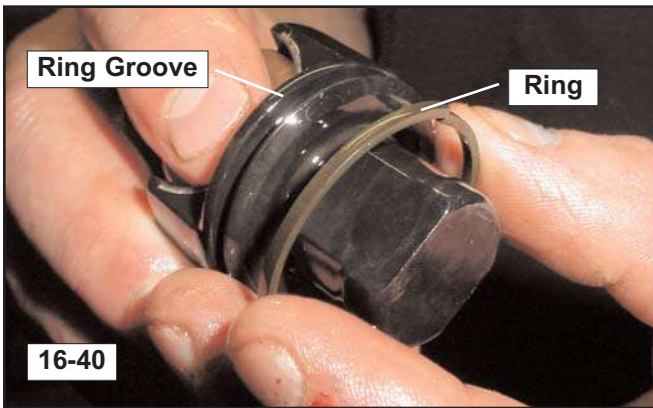

16-40

6. Once the snap rings and retainers are removed, slide the piston assemblies out one at a time and inspect them for damage. (fig. 16-39, 16-40)

Note: While inspecting the piston assemblies, pay close attention to the piston ring. Look for any signs of damage or cracking. (fig. 16-40)



16-41

7. Inspect the rollers and sleeves as well to make sure there are no scratches or other damage that may affect operation.

Assembly

1. Replace worn or damaged components, thoroughly clean all parts, then reassemble the motor by reversing the disassembly procedure.

Drive Pump (Drive Relief Valves) Disassembly & Adjustment

Required Tools

Allen Wrench/Socket
Combination/Socket wrench

1. With machine off and cool and with hydraulic actuators relaxed, remove the drive pump from the machine by following the procedure in section 11.



16-42



16-43

2. Remove the drive pressure relief valves as shown in fig. 16-42 and 16-43.



16-44

3. If adjustment is needed (see drive pressure check procedure in section 17), loosen the allen type set screw on the valve.



16-45

4. Flip the valve over, then tighten the nut to increase the pressure setting (CW) or loosen it to decrease the pressure setting (CCW).

Assembly & Test

1. Retighten the locking set screw and reinstall by reversing the disassembly procedure. Retest the pressure through the affected relief to check for proper adjustment. If it is still not correct, repeat the adjustment procedure until correct.

Drive Pump (Posi-Power Relief Valve)

Removal

Required Tools

Combination/Socket wrench



16-46

Note: The posi-power relief valve is usually a remove and replace item. However, If adjustment is required, please see the posi-power relief valve adjustment procedure in section 17 of this manual.

1. Remove the valve from the drive pump as shown in figure 16-46.

Installation

1. To install, reverse the removal procedure.

Drive Pump Disassembly

Required Tools

Combination/Socket wrench
Allen Wrench/Socket
Rubber Mallet
Screwdriver (blade type)
Snap Ring Pliers



16-47

Note: The drive pump is a tandem design where two pumps share one housing. The disassembly and assembly procedures are identical for both pumps.

1. Remove the allen bolts securing the end cap onto the pump. (fig. 16-47)



16-48

2. Remove the end of the pump as an assembly (fig. 16-48)

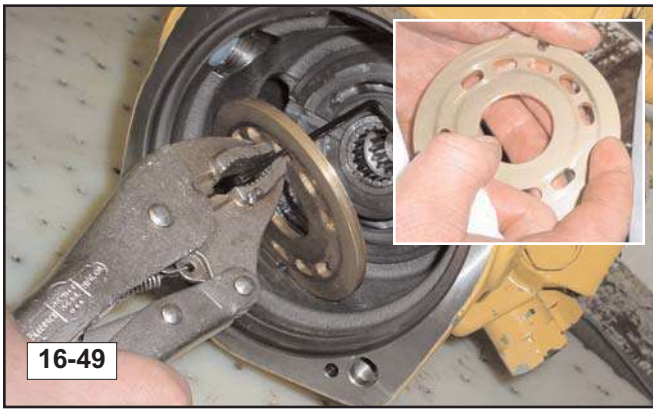

3. Remove the valve plate and inspect it for damage or wear, specifically, scratches that can be felt with a fingernail. (fig. 16-49)



4. Inspect the end of the barrel (face) and the slipper faces for similar scratches. (fig. 16-50, 16-51)

Note: To inspect the slipper faces, slide the barrel off of the assembly, then slide the slippers and pistons off of the shaft as an assembly, then inspect.

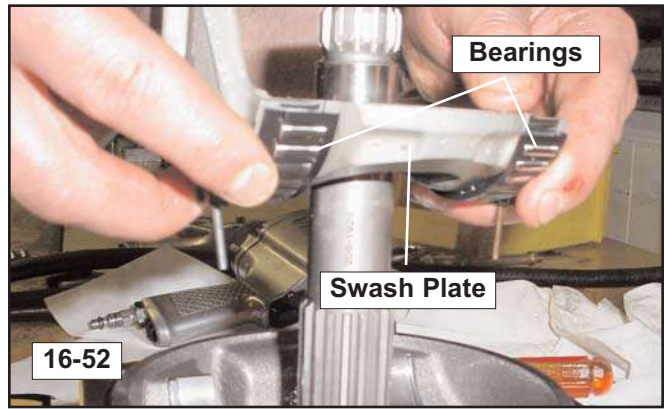

5. Remove the swash plate along with the bearings and inspect them for any damage or scratching that could affect operation. (fig. 16-52, 16-53)



6. Remove the snap ring holding the shaft, seal and bearing into the casing, then remove the seal. (fig. 16-54)

Note: If you are repairing the existing pump, you will need to replace the outer seal as it will be destroyed upon removal.

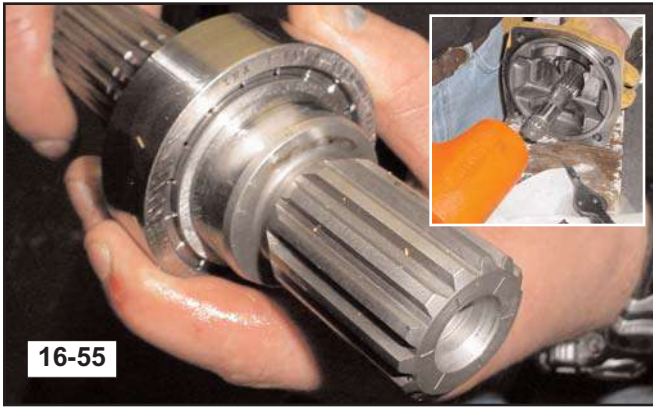

7. Using a rubber mallet, gently tap the shaft and bearing out of the casing for inspection or replacement. (fig. 16-55)

Drive Pump Assembly

Required Tools

Combination/Socket wrench
Allen Wrench/Socket
Rubber Mallet
Screwdriver (blade type)
Snap Ring Pliers



1. Using a rubber mallet, gently tap the shaft and bearing into the casing until seated. (fig. 16-56)



2. Replace the seal with a new one and install taking care not to damage it upon installation. (fig. 16-57)
3. Install the snap ring that secures the shaft, bearing, and seal in place. (fig. 16-57)



4. Flip the assembly over and lay it on a table, then remove the pivot caps from both sides as shown. (fig. 16-58)

Note: Behind each cap is a pivot that aligns with the two small pivot wires attached to the swash plate. Remove these from their cavities while installing the swash plate.



7. Once the pivots are installed, check to make sure both of them are properly mated with the pins. Using a blade type screwdriver, turn the pivots slightly to the right or left. The swash plate should move with the pivot as each one is turned. If it does not move, repeat step 6, then recheck. Once correct, reinstall the caps to secure them in place (fig. 16-61)



5. Assemble the bearing halves to the bottom of the swash plate, orient the pins so that they are vertical and then lower the assembly into place over the shaft. (fig. 16-59)

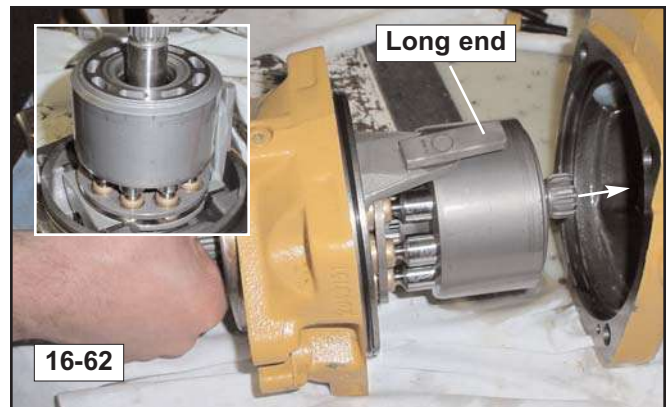

8. Reassemble the piston and barrel portion of the pump as found upon disassembly, then slide it back into the housing. (fig. 16-62, 16-63)

Note: Make sure the long end of the swash plate alignment bar is pointing inward to ensure proper operation. (fig. 16-62)

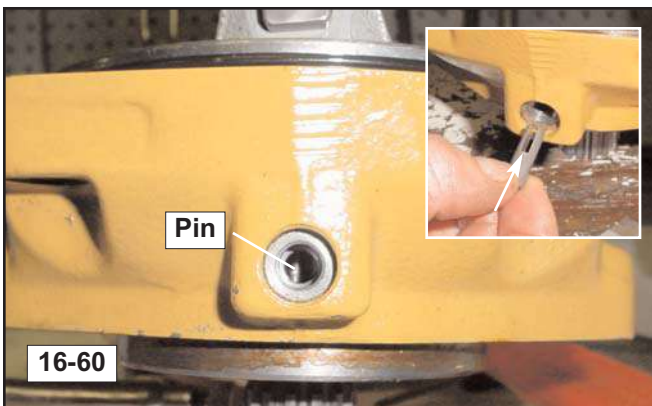

6. Once installed, make sure each pin is centered in its opening, then slide the pivot into the hole so that it mates with the pin. (fig. 16-60)



9. Reinstall and tighten the cover bolts to secure the cover. (fig. 16-63)

Auxiliary Pump Disassembly

Required Tools
Allen Wrench/Socket
Snap Ring Pliers

1. With machine off and cool and with hydraulic actuators relaxed, remove the drive pump from the machine by following the procedure in section 11.



2. Remove the bolts securing the relief valve to the housing. (fig. 16-64)

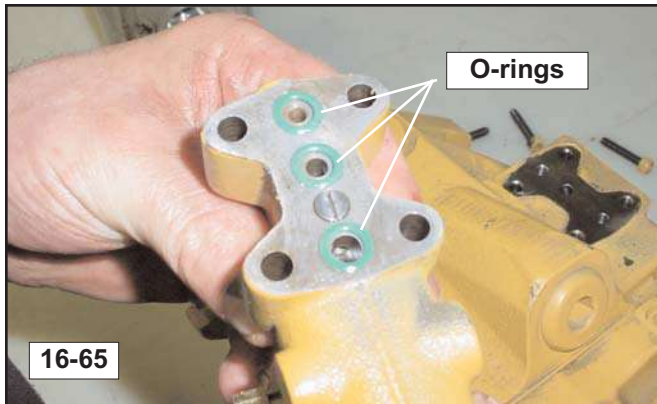

3. Inspect o-rings for proper shape and condition. Replace if necessary. (fig. 16-65)



4. Remove the Allen bolts securing the cover onto the pump. (fig. 16-66)

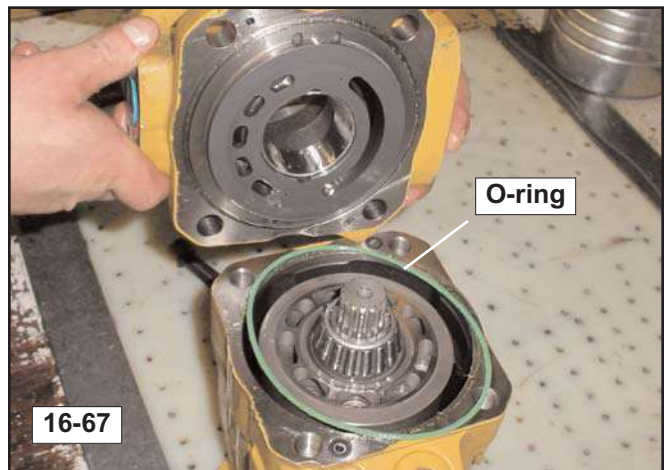

5. Lift the cover off to expose the pump components and the o-ring seal. Inspect the o-ring for damage, replace if necessary. (fig. 16-67)

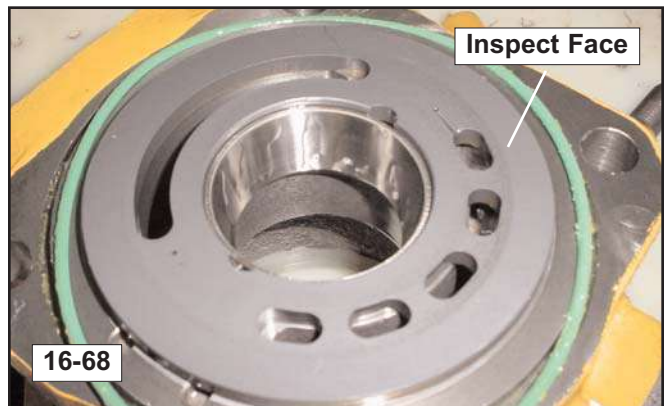

6. Inspect the valve plate face (both sides) for scratches or any other damage that can be felt with a fingernail. (fig. 16-68)

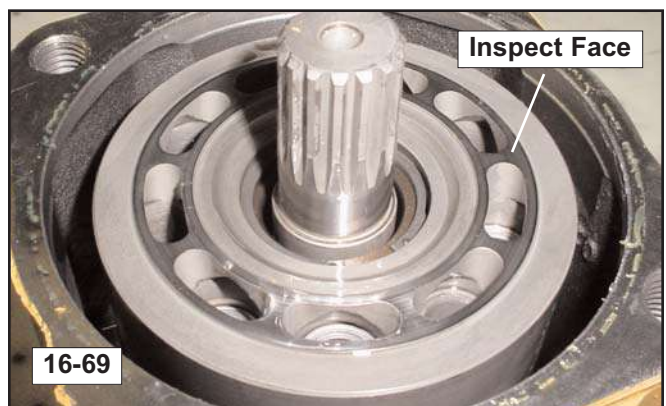

7. Inspect the barrel face for scratches or any other damage that can be felt with a fingernail. (fig. 16-69)

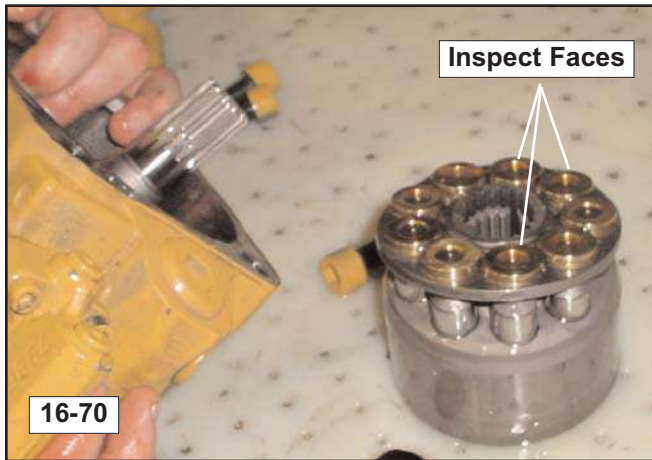

8. Remove the piston/barrel assembly and inspect the slipper faces for scratches or any other damage that can be felt with a fingernail. (fig. 16-70)

Assembly

1. To reassemble, reverse the disassembly procedure.

17. Hydraulic Pressure/Flow Test & Troubleshooting

Chapter Overview

This chapter provides hydraulic pressure and flow check, adjustment and troubleshooting procedures.

Personal Safety

!WARNING!

Improper or incomplete maintenance/repair of a Rubber Track Loader can be dangerous and may result in machine damage, injury or even death.

Do not attempt to perform any type of repair or maintenance on a Rubber Track Loader until you have read and fully understood the information in this manual.

Refer to the Operation and Maintenance manual for instructions regarding proper machine operation techniques before operating any Rubber Track Loader.

Prior to performing any type of service work on a Rubber Track Loader, read and understand Chapter 1 (Product Safety) for personal safety information.

NOTICE

Hydraulic oil must be at operating temperature to obtain accurate readings during the pressure and flow test procedures described in this section. Start and warm the engine and hydraulic oil prior to performing the test and troubleshooting procedures in this section.

Contamination Inspection

The hydraulic system can become contaminated when one or more of it's dynamic components fails or begins to wear excessively. This can introduce significant amounts of debris into the hydraulic oil.

In the event of contamination, the defective component(s) must be replaced, the remaining components must be inspected and thoroughly cleaned (if found to be reusable) and the system lines and reservoir must be thoroughly flushed to restore original function.

The hydraulic filters remove contaminants from the oil. Small amounts of debris found within the filters are to be expected, but If there is significant metallic debris found in either filter, certain components of your hydraulic system may be contaminated. To inspect for contamination, label the hydraulic filters by location and remove them. Cut them apart approx. halfway between the top and bottom of the filter and inspect them for debris. If contamination is suspected, contact the ASV service department at 1-800-346-4367.

Hydraulic Pressure/Flow Test & Troubleshooting Procedures

Test and troubleshooting procedures are provided for the following Hydraulic system components.

- Charge Pressure Check & Adjustment
- Auxiliary Valve Pressure Check & Adjustment
- Lift Arm Pressure Check & Troubleshooting
- Drive Pressure Check & Troubleshooting
- Auxiliary Flow Test & Troubleshooting

When checking hydraulic system pressures, you are essentially reading the relief valve settings of each circuit tested. If your hydraulic system and components are functioning properly, your readings should match those specified. If they differ, adjustment and or repair may be required to restore proper function.

The procedures in this section are listed in the order they are to be performed. When a pressure issue is suspected, perform these procedures to help diagnose and or repair the problem.

Charge Pressure Check

Charge pressure is used to prime the various circuits, including the joysticks, with hydraulic oil for operation. Low charge pressure could lead to sluggish operation of any and all functions.

Required Tools

Pressure Gauge 0-1000p.s.i.

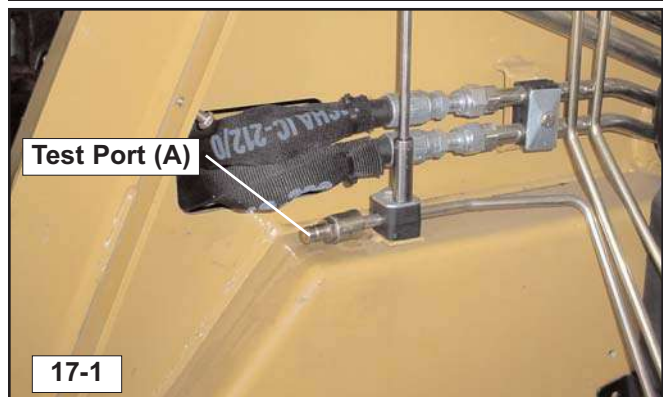

Note: The quick coupler (test port A) located in the engine compartment just inside the left lift arm tower can be used for general pressure checks and troubleshooting.

17. Hydraulic Pressure & Flow

1. Attach the gauge to test port A. (fig. 17-1) Route the gauge so that you or an assistant can read it during testing.
2. Make sure any bystanders are clear of moving components, then start the engine.
3. Allow the engine to warm up to operating temperature, then with the engine at idle, check the charge pressure. Record your reading. It should read 475 +/- 30 psi at this test port. If your reading differs, adjustment is necessary.
4. If necessary, adjust the charge relief pressure.
To adjust:
 - a) Tilt the cab as described on page 4-2 of this manual to access the pump.
 - b) Locate the charge relief valve on the top of the drive pump. (fig. 17-2)
 - c) Remove the relief valve from the top of the pump as shown in figure 17-3.
 - d) Add shims to increase the pressure setting, or remove shims to decrease the setting until within specification. (figure 17-4)
5. Retest once adjustments have been made to make sure pressure is correct. Readjust as necessary until correct.



Auxiliary Pressure Check

Required Tools

Pressure Gauges 0-1000, 0-6000 p.s.i.

Auxiliary pressure is used to drive flow style attachments. Low auxiliary pressure can produce poor performance in attachments while high pressure can cause component damage/failure in the machine or the attachment being utilized.

Note: Make sure charge pressure is set correctly prior to testing this function.

1. Tilt the cab as described on page 4-2 of this manual to access the valve.
2. Locate the test port on the top of the lift arm control valve. (fig. 17-5)
3. Attach the 0-1000psi hydraulic gauge to test port (B) on the top of the valve. Route the gauge so that you or an assistant can read the gauge while performing the test procedures. (figure 17-5, 17-6)
4. Start the machine and with the auxiliary hydraulic switch off (no functions activated) and the engine at idle, you should read 218 psi at test port (B).
5. Attach the 0-6000psi gauge to test port B, then activate the low or high flow auxiliary hydraulics with no auxiliary attachment fastened to the quick couplers. This action will send oil over relief and you will read the actual pressures required to activate the relief valve for each circuit. Do this for both the high and low flow circuits in both directions. Record the pressure readings.

Check your readings against those stated below. If your readings differ, an adjustment and or repair may be required.

Pressures should read: (at test port B)

- 218 +/- 10 PSI with system relaxed (**standby**).
 - 3000 +/- 100 PSI with Low Flow activated.
 - 3000 +/- 100 PSI with High Flow activated.
6. If necessary, adjust the relief settings on the auxiliary standby or high pressure valves. (figure 17-7)
To adjust:
 - a) Remove the cap covering the affected relief valve.
 - b) Using an allen wrench, turn the adjustment screw clockwise to increase the setting or counter-clock wise to reduce it until within specification.

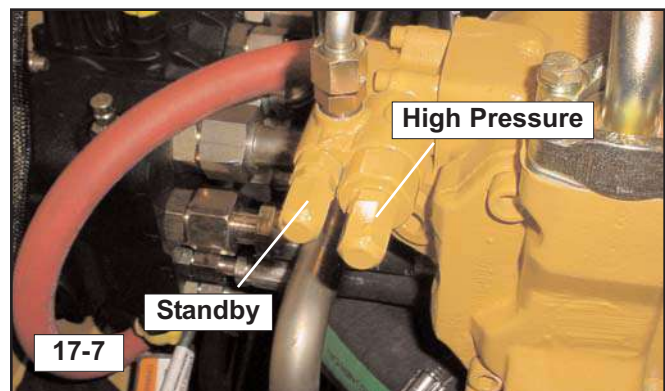
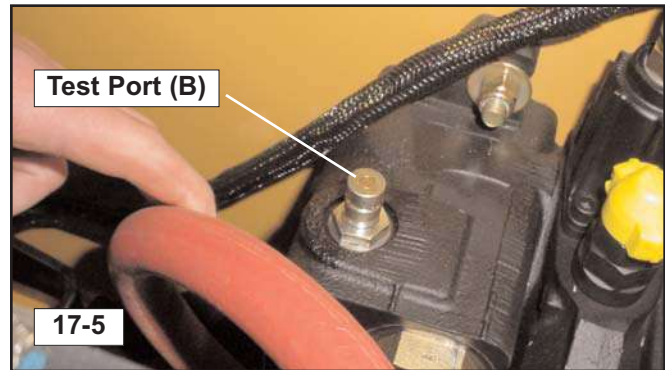

Lift Arm Pressure Check

Required Tools
Pressure Gauge 0-6000 p.s.i.

Lift arm pressure is used to lift loads or “break-out”. Low lift arm pressure can produce a weak lift arm function while high lift arm pressure can damage lift arm and hydraulic components.

Note: Make sure auxiliary circuit pressures are set correctly prior to testing this function.

1. Attach a hydraulic gauge to test port B. Route the gauge so that you or an assistant can read the gauge while testing these functions. (figure 17-6)
2. Raise the lift arms all the way up and continue holding the joystick even when the lift arms stop. Record the pressure readings. Then lower the lift arms to the stops and continue holding the joystick. Record the pressure readings. Repeat this process with the bucket dump/curl functions.
3. Check your readings against those stated below. If your readings differ, adjustment or repair may be necessary. (figure 17-8)

Pressures should read: (at test port B)

- 3000 +/- 100 PSI when the lift arms or bucket are in the up/curl position.
 - 3000 +/- 100 PSI when the lift arms or bucket are in the down/dump position.
4. If any of the readings are low, reverse the function and recheck. If reading is within specification in that direction, replace the opposing relief valve.

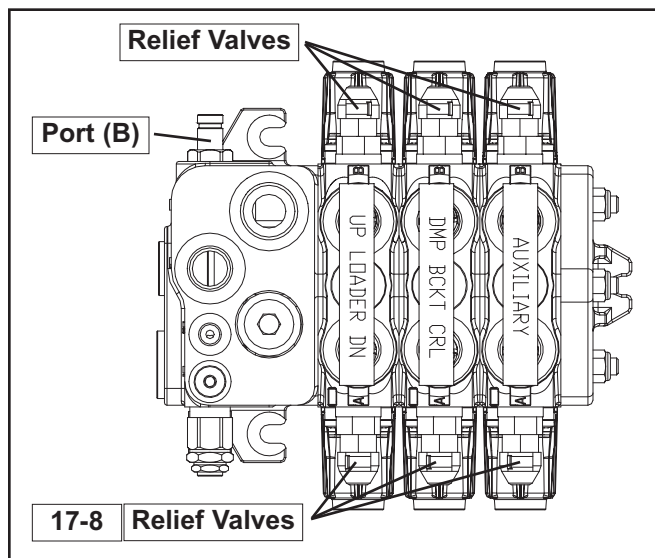

Drive Pressure Check

Required Tools
Pressure Gauge 0-6000 p.s.i.

!WARNING!

This procedure should only be performed if you suspect a drive pump or drive motor is faulty. The procedure is difficult and in performing it, you risk contaminating your hydraulic system if your equipment and working environment is not clean.

Make certain all couplers, fittings and hoses used during this process are clean and free of contaminants that may potentially cause damage to the hydraulic pump and or system components!

Drive pressure is used to turn the drive motors that power your tracks. Low pressure can cause decreased drive motor performance resulting in sluggish maneuvering, decreased speed and or uneven forward or reverse motion.

1. Remove the plug from the port you would like to test and insert a quick coupler similar to the one in port A or B.

Note: There are 4 drive pump test ports. The left side ports are shown in figure 17-10 and the right side ports are located to the right of the drive ports they test.

2. Attach the hydraulic gauge to the port(s) you are trying to test and route the gauge so you or an assistant can read the gauge during testing.
3. Position the machine so that the lift arms are resting against the chassis stops and the front edge of the bucket is facing, centered on and in contact with an **IMMOVABLE** object.
4. Move the drive control fully forward in an attempt to drive the machine forward. This will force oil over the relief valve and give you a reading for the circuit you are tapped into.
5. Attach a heavy-duty chain capable of restraining the machine securely to the bucket and an **IMMOVABLE** object.
6. Move the drive control fully rearward in an attempt to drive the machine in reverse. This will force oil over the relief valve and give you a reading for the circuit you are tapped into.
7. Check all four ports in this same manner and record your readings.

Check your readings against that stated below. If your readings differ, relief replacement and or component repair may be required.

Pressures should read:

- 5500 PSI when the relief is reached in attempted forward or reverse motion.

Drive pressure troubleshooting:

8. If one reading is low, swap the relief valve with a similar one and recheck. If the reading improves, replace the faulty relief valve.
9. If two readings are low, but on different circuits (pumps), perform step 8 for both.
10. If both readings are low on one pump, disconnect the drive hoses from the suspected ports and plug them at the pump. Cap the hoses to prevent contamination and then recheck the pressures at those ports. If the reading improves, the drive motor is at fault. If the reading does not improve, one pump (in the tandem assembly) is at fault.
11. If all 4 readings are low, it is unlikely that all four relief valves are faulty. The tandem pumps are most likely not working properly.

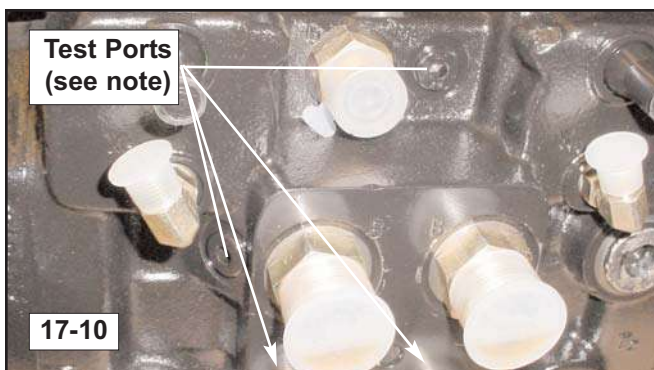
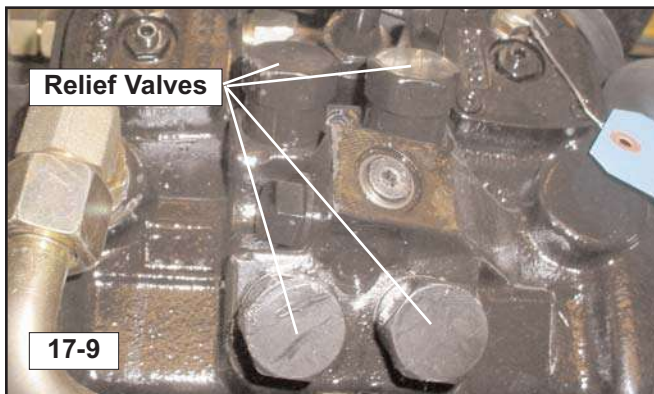

Posi-Power Pressure Check

Posi-power is a function of the tandem drive pump assembly. The posi-power control reads charge flow (which is directly related to engine rpm) and adjusts drive pump flow to maximize torque and prevent engine stall during high load conditions.

!WARNING!

This procedure should only be performed if you suspect that the Posi-Power relief valve is faulty. In performing this procedure you risk contaminating your hydraulic system if your equipment and working environment is not clean.

Make certain all couplers, fittings and hoses used during this process are clean and free of contaminants that may potentially cause damage to the hydraulic pump and or system components!

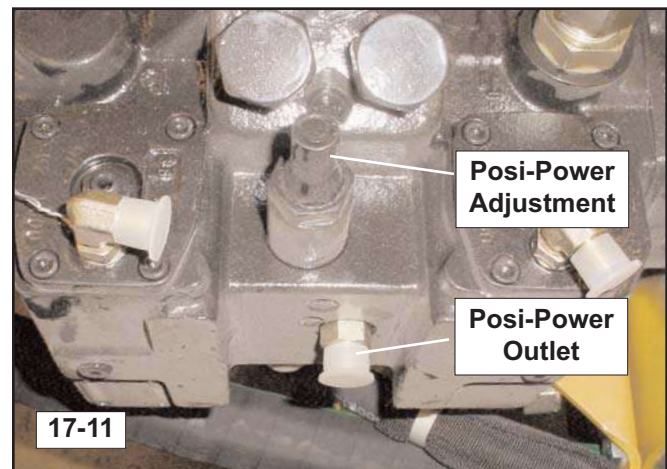

To check Posi-Power pressure:

1. With the engine off and cool, disconnect and cap the posi-power outlet hose from the port on the top of the drive pump assembly. (figure 17-11)
2. Remove the fitting from the pump assembly and install a quick coupler similar to the one installed in test port A or B in its place.
3. Attach a gauge to the quick coupler and route it so that you or an assistant can read the gauge during operation.
4. Make sure all bystanders are clear of moving parts and start the engine.
5. At low rpm, posi-power pressure should read 180 +/- 40 psi. (475 +/- 40 at high rpm)

17. Hydraulic Pressure & Flow

6. If your reading is low, remove the cap and loosen the jam nut on the posi-power adjustment screw and turn it counter clockwise until it stops then retighten the jam nut. (figure 17-11)
 - a) If the screw was already turned completely out and pressure reads lower than specified, the posi-power relief valve is faulty and should be replaced.
 - b) If you were able to turn the screw out, recheck posi-power pressure to see if the reading is now within specification. If it is, the system should function properly. If it did not improve, the posi-power relief valve is faulty and should be replaced.

To Adjust Posi-Power:

1. Loosen the jam nut and then turn the screw to adjust for more or less posi-power function. (figure 17 -11)
 - a) Turn the screw clockwise to increase function and limit pump flow during high load conditions. (less likely to stall)
 - b) Turn counter-clockwise to decrease function and maximize pump flow during high load conditions. (more likely to stall)
2. Tighten the jam nut while holding the set screw in place to keep desired setting.

Auxiliary Flow Test

The SR-70 and SR-80 are equipped with both high and low flow auxiliary circuits. If an auxiliary flow problem is suspected, the following procedures should be performed.

Note: If an auxiliary circuit problem is suspected, perform all pressure test and adjustment procedures as necessary prior to attempting the perform the flow test procedure. Most issues will be solved with the pressure test and adjustment procedures, but if a problem still persists after all pressures are correctly set, proceed with the flow test.

Required Tools

Flow Meter (with variable loading valve)

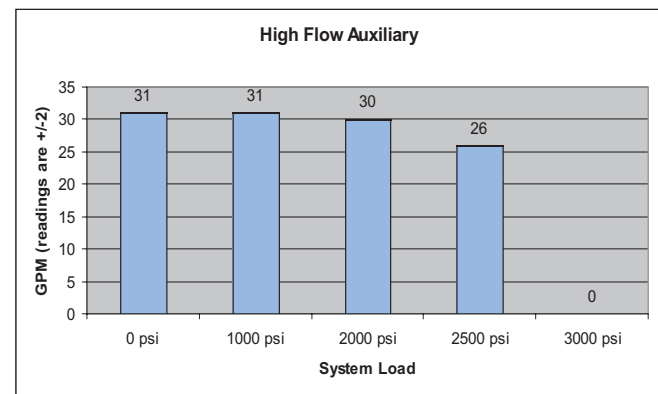
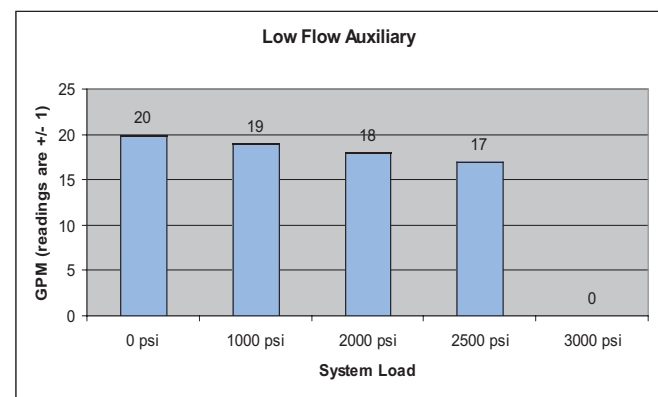

Note: The charts above give the acceptable ranges for fluid flow when loaded to the levels indicated. The low flow values are to be understood as acceptable if within 1 gpm of the specified value. The high flow values are acceptable if within 2 gpm of the specified value.

To test flow:

1. Attach a flow meter to the quick couplers of the circuit to be tested. (high or low flow)
2. Start the machine and activate the circuit.
3. Record and compare your readings with those of the charts above in both directions.

Flow Troubleshooting

If your readings differ from those listed on the charts, identify the symptom you are experiencing in the list of possible problems below and follow the steps to identify and correct the problem.

Problem 1:

Both high and low flow readings are less than specified.

Possible causes:

1. Auxiliary relief valve pressure setting incorrectly (see page 17-3)
2. Quick coupler block pressure release valve stuck in down (release) position.
3. Auxiliary pump malfunctioning or faulty.
4. Engine RPM too low.

Problem 2:

High flow readings are less than specified (low flow is within specification).

Possible causes:

1. Low charge pressure.
2. Control valve spool malfunction.

Note: Make sure that the high flow reading is greater than the low flow reading. If they are equal, the problem is most likely electrical.

Problem 3:

Flow is within specifications in one direction, but lower than specified in the other.

Possible causes:

1. Auxiliary line relief valve in need of replacement. (see page 17-4 for test instructions and figure 17-8 for location)
2. Control valve spool malfunction.

Problem 4:

Low flow readings are less than specified (high flow is within specification).

To correct:

1. Turn the adjustment screw on the pilot generation block pressure reducing valve clockwise to increase the flow within the low flow circuit until correct. (see page 3-5, view D, item 5 to locate)

Problem 5:

Low flow readings are higher than specified (High flow is within specification).

To correct:

1. Turn the adjustment screw on the pilot generation block pressure reducing valve counter clockwise to decrease the flow within the low flow circuit until correct. (see page 3-5, view D, item 5 to locate)

Problem 6:

High and low flow functions only work in one direction.

Possible causes:

1. Wire broken or disconnected at the pilot generation block.
2. Solenoid coil malfunction. (see page 3-5)
3. Solenoid spool malfunction. (see page 3-5)
4. Faulty auxiliary hydraulic switch.

Problem 7:

Low flow works as intended when using the continuous switch, but does not work when using the variable flow thumb switch.

Possible causes:

1. Variable flow fuse blown.
2. Power wire to variable flow switch broken or disconnected. (BU-16 see electrical schematic)
3. Variable flow switch malfunction.
4. If the switch works in one direction, but not the other, check the pressure reducing proportional valves and the wires that connect them to the wiring harness for proper condition and function. (see page 3-5, view B item 6, view D item 4)

18. Troubleshooting

Chapter Overview

This chapter contains basic troubleshooting procedures for the SR-70 and SR-80 Rubber Track Loaders.

Additional troubleshooting aids are provided in Chapter 3 (Circuit Diagrams) and in chapters containing disassembly and assembly procedures for the appropriate component or assembly.

Personal Safety

!WARNING!

Improper or incomplete maintenance/repair of a Rubber Track Loader can be dangerous and may result in machine damage, injury or even death.

Do not attempt to perform any type of repair or maintenance on a Rubber Track Loader until you have read and fully understood the information in this manual.

Refer to the Operation and Maintenance manual for instructions regarding proper machine operation techniques before operating any Rubber Track Loader.

Prior to performing any type of service work on a Rubber Track Loader, read and understand Chapter 1 (Product Safety) for personal safety information.

Visual Inspection

Prior to troubleshooting, walk around the machine and perform an overall visual inspection. Look for missing, loose, worn or broken parts. Pay particular attention to the following items:

- Track tension
- Fluid levels
- Fan belt tension and condition
- Hoses (no visible sign of wear)
- Fittings (no apparent leaks)
- Battery cables
- Fuse panel (fuses in place and operational)
- Controls (for neutral)

A simple visual inspection and operational check can identify many problems without the need for extensive troubleshooting. However, if these checks indicate a problem that requires further analysis, proceed to Troubleshooting.

General Troubleshooting

The most effective way to prevent a malfunction from occurring is to closely follow the recommended maintenance schedule and instructions throughout the life of the machine. However, if a malfunction does occur, finding the problem and fixing it quickly are important. This section covers a select set of symptoms that may occur and suggests possible causes.

Problem 1: **Machine will not crank over.**

Possible causes

1. Continuous high flow switch activated.
2. Continuous low flow switch activated.
3. Power quick-attach switch in unlocked position. (if equipped)
4. Battery cables loose or corroded.
5. Ignition fuse blown.
6. Main starter fuse blown.
7. Starter relay malfunctioning.
8. Weak or dead battery.
9. Faulty continuous hydraulic flow switch.
10. Faulty power quick attach switch.
11. Faulty ignition switch.
12. Faulty starter.
13. Loose, broken or disconnected wiring at key, relay or starter.
14. Main power fuse (60-80 amp) blown.

18. Troubleshooting

Problem 2:

Machine cranks, but will not start.

Possible causes

1. Fuel tank empty, fuel filter plugged or fuel line restricted.
2. Battery discharged (engine rotates slowly).
3. Injection pump fuse blown.
4. Power relay (B) fuse blown (40 amp).
5. Faulty power relay (B).
6. Loose, broken or disconnected wiring at injection pump, fuel pump or fuse.
7. Glow plugs not pre-heating (look for black smoke).
 - a) Main glow plug fuse blown.
 - b) Glow plug relay malfunctioning.
 - c) Loose, broken, or disconnected wiring at ignition switch, relay or glow plug ground strip.
 - d) Faulty glow plugs.
8. Faulty ignition switch.
9. Loose, broken or disconnected wiring in starting circuit.
10. Loose, broken or disconnected wiring at fuel shutoff solenoid.
11. Air in fuel system or defective fuel injection pump.

Problem 3:

Machine starts, but hydraulics will not operate.

Possible causes

1. Operator not in seat.
2. Seat belt not fastened.
3. Safety relay fuse and or or safety solenoid fuse for seat belt or operator presence safety switches blown.
4. Faulty operator presence safety switch.
 - a) Test for continuity through operator presence and seat belt switches. Adjust or replace as necessary.
5. Loose, broken or disconnected ground wires (check ground connections behind the operator seat, from cab to chassis and on the chassis crossmember.)
6. Faulty safety relay.
7. Faulty safety solenoid or safety solenoid spool.
8. Loose, broken or disconnected wiring at fuse, relay, or safety solenoid.
9. Low charge pressure.

Problem 4:

Lift arm/bucket controls are operational, but tracks will not move.

Possible causes

1. Leak in feed line to drive control joystick (pilot control).
2. Loose, broken or disconnected wire to DA control solenoid.
3. Drive control joystick (pilot control) malfunction.
4. Low charge pressure.
5. Parking brake switch in on position.
6. Faulty parking brake switch.

Problem 5:

Tracks are operational, but lift arms will not move.

Possible causes

1. Continuous hydraulic flow switch activated, sending oil over relief. (lift arms work, but move slowly)
If auxiliary flow hydraulics work check for:
 - a) Leak in feed line to lift arm control joystick (pilot control).
 - b) Lift arm control joystick (pilot control) malfunction.
 - c) Lift arm control valve assembly malfunction.
If auxiliary flow hydraulics do not work check for:
 - a) Main auxiliary relief malfunction.
 - b) Faulty auxiliary pump.

Problem 6:

Lift arms are operational, but high/low flow auxiliary circuits are not.

Possible causes

1. Auxiliary hydraulic fuse blown.
2. Faulty ground in at chassis crossmember.
3. Faulty auxiliary hydraulic switch.
4. Faulty auxiliary hydraulic solenoid at pilot generation block.
5. Loose, broken or disconnected wire at fuse, auxiliary hydraulic switch, pin connector P10.
6. Auxiliary hydraulic pilot generation spool stuck in closed position.
7. Faulty or improperly connected quick coupler.
8. Quick coupler block pressure release stuck in down (open) position.

Problem 7:

Multiple switches/electrical accessories are not operational in ON or RUN position.

Possible causes

1. Power A or B fuse blown.
2. Faulty power relay (A or B).
3. Faulty ignition switch.
4. Loose, broken or disconnected wiring at ignition switch, fuse or relay.

Problem 8:

Battery will not charge/maintain charge.

Possible causes:

1. Loose alternator belt.
2. Alternator fuse blown.
3. Faulty alternator diode.
4. Loose, broken or disconnected wiring at battery, alternator, diode or fuse.
5. Excessive current draw with key in "off" position.
6. Faulty battery.
7. Faulty alternator.

Problem 9:

Lift arm control joystick will not lock into float position.

Possible causes

1. Float magnet fuse blown.
2. Loose, broken, or disconnected wiring at fuse, float detent magnet, or pin connector P8.
3. Faulty float detent magnet.

Problem 10:

Lift arms will not float, engine labors and lift arms create down pressure when float is engaged.

Possible causes

1. Engine RPM too low.
2. Low charge pressure.
3. Lift arm control joystick malfunction (pilot control).
4. Lift arm control valve malfunctioning.

Problem 11:

Hydraulic oil temperature elevated; hydraulic system overheating.

Possible causes

1. Debris plugging oil cooler, limiting airflow.
2. Low hydraulic oil level.
3. Loose or missing fan belt.
4. Damaged or missing cooling fan blades.
5. Incompatible attachment.
 - a) Attachment must match machine flow capabilities.
 - b) Attachment hose inside diameter must be at least 1/2" for low flow and 3/4" for high flow.
 - c) Low flow attachment coupled to high flow circuit.
6. Faulty hydraulic oil temperature sending unit.
7. Faulty quick coupler.
8. Cooler bypass relief open.

Note: Cooler bypass should open at 80 PSI.

Problem 12:

Engine coolant temperature elevated; engine overheating.

Possible causes:

1. Low coolant level.
2. Debris plugging radiator, limiting airflow.
3. Damaged or missing cooling fan blades.
4. Loose or missing fan belt.
5. Faulty engine coolant temperature gauge.

Engine/Machine Troubleshooting

When a problem occurs that effects engine performance or function, it is important to determine whether or not the problem lies with the machine itself, or with the engine. A machine problem should be repaired by an ASV dealer, while an engine specific problem should only be repaired by a representative of the engine manufacturer. Making this determination will ensure timely and appropriate service to help minimize down-time.

Problem:

Hard starting

check for:

1. 12V power to glow plugs. (With test light or multi-meter, measure voltage at **green** glow plug common power lead.)
 - a) If power is not present, see problem 1, step 7.
2. Water in fuel.
3. Proper grade and quality fuel.

Problem:

Low power

check for:

1. Dirty, clogged, or restricted fuel filter.
2. Adequate supply of fuel to engine (fuel lines).
3. Water in fuel.
4. Proper grade and quality fuel.

Problem:

No start

check for:

1. 12V power at fuel shutoff solenoid. (With test light or multi-meter, measure voltage at **white** power lead entering the solenoid.)
 - a) If no power is present, see problem 1, step 3-6)
2. Ensure 12V power to fuel pump. (With test light or multi-meter, measure voltage at **white** power lead entering the electronic fuel pump.)
3. Low fuel.
4. Out of fuel. (ensure proper gauge/sending unit function. Inspect tank for fuel)
5. Blocked or restricted fuel line. (try alternate/remote fuel supply to pump.)
6. Water in fuel.
7. Proper grade and quality fuel.

If any of the above conditions are present, the problem lies with the machine and should be serviced by an ASV dealer. If the conditions listed above are not present, the problem lies with the engine and it should be serviced by a Perkins engine repair facility to comply with the conditions of the engine warranty.

19. Lubricant & Fuel Specifications

Chapter Overview

When replacing or replenishing the fluids and lubricants in an ASV Rubber Track Loader, use ASV Posi-Lube products. This ensures that the new fluids and lubricants match those originally installed when the machine left the ASV factory. Posi-Lube products were developed for, tested and approved by ASV to assure optimum life and performance in all ASV Rubber Track Equipment, when used as recommended.

Fluids

Engine Oil

- ASV Posi-Lube™ Heavy Duty Engine Oil, 10W-30
Capacity: 9 U.S. quarts (including filter)
P/N: 0300-767 1 quart
P/N: 0402-838 12 quarts
P/N: 0402-839 1 gallon
P/N: 0402-840 6 gallons

Engine Anti-freeze/Coolant

- ASV Posi-Lube™ Long-Life 50/50 Antifreeze/Coolant
Capacity: 3.125 U.S. gallons
P/N: 0300-766 1 gallon
P/N: 0402-841 6 gallons

Hydraulic Oil

- ASV Posi-Lube™ Premium All Season MV Hydraulic Oil
Capacity: 20 U.S. gallons (including filters)
P/N: 0400-253 5 gallons
P/N: 0402-833 55 gallons

Grease (general-use)

- ASV Posi-Lube™ Multi-Purpose EP Lithium Grease
P/N: 0300-769 1 tube
P/N: 0402-844 10 tubes
P/N: 0402-834 40 tubes

If Posi-Lube™ products are not available, use high quality substitutions that meet or exceed factory installed fluid specifications.

Fuel Specifications

In North America, diesel fuel, distilled from crude oil, identified as No. 1-D or No. 2-D in “ASTM D975” generally meet machine requirements.

20. Service Aids & Supplements

General Torque Specifications

Inch Fasteners

<u>Thread Size</u>	<u>Standard Torque</u>
1/4"	9 +/- 2 lb ft
5/16"	18 +/- 4 lb ft
3/8"	35 +/- 7lb ft
7/16"	50 +/- 11 lb ft
1/2"	75 +/- 15 lb ft
9/16"	120 +/- 22 lb ft
5/8"	160 +/- 30 lb ft
3/4"	275 +/- 37 lb ft
7/8"	460 +/- 60 lb ft
1"	660 +/- 75 lb ft
1-1/8"	960 +/- 110 lb ft
1-1/4"	1320 +/- 150 lb ft
1-3/8"	1780 +/- 220 lb ft
1-1/2"	2280 +/- 260 lb ft

Metric Fasteners

<u>Thread Size</u>	<u>Standard Torque</u>
M6	12 +/- 3 Nm
M8	28 +/- 7 Nm
M10	55 +/- 10 Nm
M12	100 +/- 20 Nm
M14	160 +/- 30 Nm
M16	240 +/- 40 Nm
M20	460 +/- 60 Nm
M24	800 +/- 100 Nm
M30	1600 +/- 200 Nm
M36	2700 +/- 300 Nm

Terex Construction Americas

8800 Rostin Road

Southaven, MS 38671

(888)-201-6008

(662)-393-1800

www.terex.com