

# Häggloader

A unique continuous  
loading system



# The Häggloader concept



To drive long tunnels cost-effectively, you need high capacity equipment designed to operate efficiently in narrow or confined spaces. Our continuous loader – the Häggloader – meets this need by increasing efficiency while providing lower costs.

## **The Häggloader never stops**

Continuous loading means exactly what it says: loading without interruptions. Unlike conventional loaders, the Häggloader does not need to move around during the loading operation. This means that, when used in optimal conditions, the Häggloader has superior loading and cost-saving abilities.

## **Reduce your number of bays**

Making niches, or loading bays, is costly and time-consuming. With the Häggloader you can reduce the number of loading bays. The material is simply loaded onto a conveyor that continuously drops it onto the truck.

## **Better air, lower cost**

Good ventilation is essential in any tunneling or mining project, but good air is not free. The Häggloader operates on electric power, which reduces the need for ventilation by up to 75% and keeps noise levels to a minimum.



### ⊕ High productivity, low cost

Reduced cycle times between rounds thanks to uninterrupted loading operation

Reduces the need for loading bays

Minimized ventilation requirements

# A Häggloader for every need

The Häggloader is available in various designs and sizes to suit different needs, no matter how you choose to run your operation, there's a solution for you

Two different boom applications are available on all models – dual digging arms or backhoe. The dual digging arms provide high productivity and loading capacity. The backhoe is multi-functional, flexible and

can also perform digging and scaling. The Häggloader 7 and 10 are diesel-electric hybrids that provide full flexibility to run your operation anywhere, anytime.

## ⊕ Shared benefits

Various designs to suit different needs

Matches all types of haulage equipment

Electric or diesel operation of all functions



## Häggloader 7HR and 7HR-B

Loading capacity up to 3.5 m<sup>3</sup>/min. Tunnel drift size from 8 m<sup>2</sup>. Rubber tired, four-wheel drive with independent front and rear axle steering. Hydrostatic drive train. Electric or diesel repositioning.

Dimensions	7HR	7HR-B
Length	8 629 mm	9 153 mm
Height	2 268 mm	2 268 mm
Width	2 195 mm	2 195 mm
Weight	14 500 kg	14 500 kg

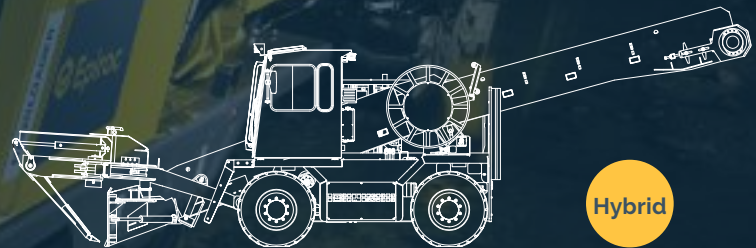

## Häggloader 10HR and 10HR-B

Loading capacity up to 5m<sup>3</sup>/min. Tunnel drift size from 14 m<sup>2</sup>. Rubber tired, four-wheel drive with independent front and rear axle steering. Hydrostatic drive train. Electric or diesel repositioning.

Dimensions	10HR	10HR-B
Length	10 723 mm	11 209 mm
Height	2 977 mm	2 977 mm
Width	2 874 mm	2 874 mm
Weight	21 900 kg	21 900 kg

# Performance through flexibility

Thanks to uninterrupted loading operations with the Häggloader, both cost and time for your project can be substantially reduced and compared to other continuous loaders on the market. The Häggloader is superior in terms of flexibility, productivity and cost savings.

The Häggloader is designed to be more productive than any other underground loading equipment. For example, the open type conveyor in combination with the wide digging arm bridge allows large rocks to pass through. Thanks to this, the Häggloader will continue production without interruption even in blocky conditions.

## Keeping up the speed

The tramming speed of the Häggloader is no less than 12 km/h, allowing rapid in-and-out transportation. It only needs diesel for tramming, which minimizes fuel consumption, emission rates and the need for ventilation.

## Safe and ergonomic

The Häggloader 10HR/10HR-B features a comfortable cabin which is FOPS approved and has an ergonomically designed driver's seat with joysticks mounted in the armrests. It is also equipped with air conditioning, a heater, protection bars, LCD display, and two rear-mounted cameras for maximum visibility.

## + Main benefits

**Superior productivity and flexibility** thanks to different boom configurations and the open-type conveyor

**Energy efficient** through electrically powered operation and low diesel consumption when tramming

**Safe, comfortable** work environment in a FOPS-approved, ergonomic operator's compartment

Two different boom applications are available on all models – dual digging arms for high productivity and backhoe for superior flexibility



Strong, centrally mounted chain with wing-shaped flights allows stacked material to pass



The open type conveyor in combination with a wide digging arm bridge allows large rocks to pass through.



Wheel mounted with high tramping capacity, low diesel consumption, independent front and rear axle steering and four-wheel drive.



The water sprinkler system provides efficient dust control.

The conveyor is available in different lengths and is individually adjustable in height at both the front and rear hinges



Strong dozer blades collect the material and can also be used for roadwork

## Häggloader 7 HR and 7 HR-B

### Engine

Brand/model: Deutz TD 2011 L04i	Tier 3/Stage IIIA
Power rating at 2 600 rpm	54.7 kW

### Standard electrical system

	Häggloader 7HR	Häggloader 7HR-B
Electric motor	55 kW	55 kW
Voltage	400-690 V 1 000 V	400-690 V 1 000 V
Battery capacity	2x12 V-70 Ah	2x12 V-70 Ah
Generator capacity	40 A	40 A
Lights	8x40 W LED	8x40 W LED

### Volume data, service

Engine oil volume	11 l
Fuel tank	96 l
Hydraulic tank including cooler	250 l

### Functional data

	Häggloader 7HR	Häggloader 7HR-B
Tractive effort (4 wheel drive)	7 200 kp	7 200 kp
Steering	4 wheel	4 wheel
Max work gradient (uphill)	1:5 (20%)	1:5 (20%)
Max work gradient (downhill)	1:7 (14%)	1:7 (14%)
Loading capacity	Approx. 3.5 m <sup>3</sup> /min	Approx. 3 m <sup>3</sup> /min
Tires	8.25x15'	8.25x15'
Wheel base	2 000 mm	2 000 mm
Track width	1 860 mm	1 860 mm
Weight	14 500 kg	14 500 kg

### Transmission

Maximum travel speed	
Electric	3 km/h
Diesel	10 km/h

### Options

	Häggloader 7HR	Häggloader 7HR-B
Quick tool	-	○
Scaling hook for bucket	-	○
Hydraulic breaker	-	○
Electrical cable	○	○
Fire suppression system	○	○
Extended conveyor	○	○
High altitude	○	○
Cold weather package	○	○

## Features

### Safety

- Spring applied hydraulically released parking and emergency brake (SAHR)
- FOPS certified operator's compartment

### Sustainability

- Hybrid technology provides operation on both diesel and electrics
- The electro-hydraulic drive means low ventilation demand and improved working environment
- The chassis and conveyor are made of heavy duty steel plate welded in a continuous process to ensure maximum fatigue strength
- Hydraulic cylinders with internal damping to extend lifetime and minimize vibrations for operator

### Productivity

- The conveyor can be raised and lowered to suit the loading height of different haulage vehicles
- The dozer blades clean the floor effectively, thus eliminating the need for manual clean up
- Two different boom options – dual digging arms or backhoe. The dual digging arms provide high productivity and loading capacity. The backhoe is multi-functional, flexible and can also perform digging and scaling.
- A built-in sprinkler system controls dust effectively
- Open type conveyor in combination with wide digging arm bridge allows large rocks to pass through
- Load sensing variable displacement hydraulic pump for reduced energy consumption



# Technical specifications

## Hägloader 7HR

Side view

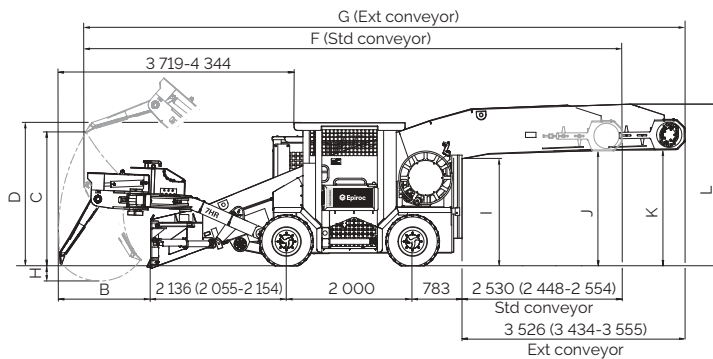

Front view

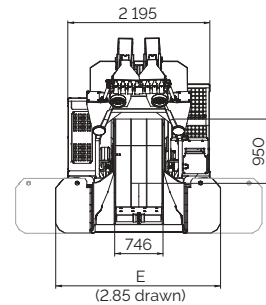

Turning radius

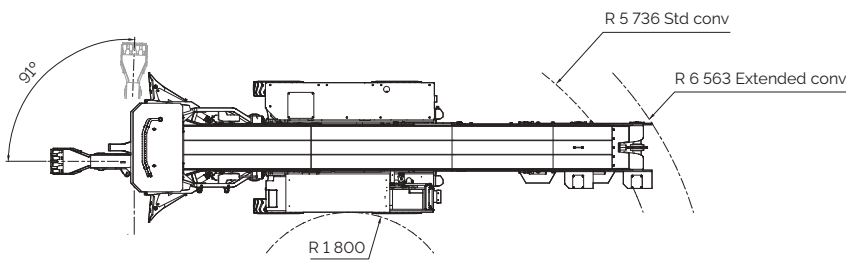

### Dimensions

Digging width (m)	2.85	3.4	4.0
Reach (mm), B	1 462	1 740	2 087
Height (mm), C	1 953	2 131	2 134
Tramming hight (mm), D	2 268	2 268	2 268
Dozer blade width, std (mm), E	2 550	3 200	3 800
Total length tramming std conv. (mm), F	8 629	8 830	8 999
Total length tramming ext conv. (mm), G	9 613	9 815	9 983
Digging depth (mm), H	236	279	567
Height between conv. and ground (mm), I	1 802 (1 694-2 167)		
Height between conv. and ground (mm), J	1 950 (1 807-2 453)		
Height between conv. and ground (mm), K	1 979 (1 816-2 555)		
Conveyor total height (mm), L	2 701 (2 546-3 245)		

## Hägloader 7HR-B

Side view

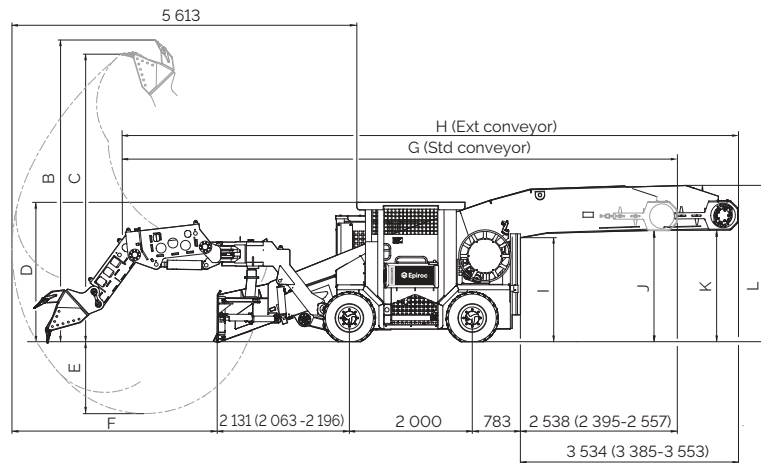

Front view

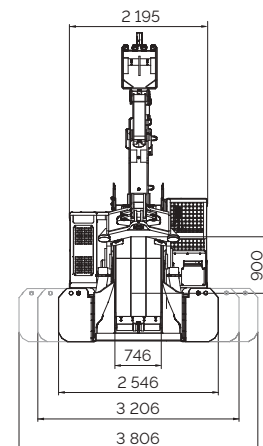

Turning radius

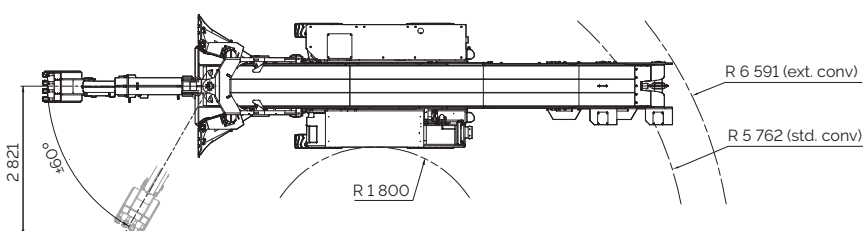

### Dimensions

Height (mm), B	4 909
Height (mm), C	4 681
Tramming hight (mm), D	2 268
Digging depth (mm), E	1 170
Reach (mm), F	3 363
Total length tramming, std conv. (mm), G	9 153
Total length tramming, ext conv. (mm), H	10 136
Height between conv. and ground (mm), I	1 808 (1 691-2 190)
Height between conv. and ground (mm), J	1 960 (1 804-2 489)
Height between conv. and ground (mm), K	1 989 (1 812-2 602)
Conveyor total height (mm), L	2 710 (2 541-3 288)

## Häggloader 10 HR and 10 HR-B

### Engine

	Standard	Alternative*
Brand/model: Deutz TCD	2012 LO4 2 V, Tier 3/Stage IIIA	4.1 L4, Tier 4 final/EU stage IV
Power rating at 2 300 rpm	100 kW	105 kW

\*Please note! Requires Ultra Low Sulphur Diesel and low ash engine oil.

### Standard electrical system

Electric motor	76 kW
Voltage	400-690 V
	1 000 V
Battery capacity	2x12 V-135 Ah
Generator capacity	100 A
Lights	8x35 W LED

### Volume data, service

Engine oil volume	15.5 l
Fuel tank	96 l
Hydraulic tank including cooler	300 l

### Functional data

	Häggloader 10HR	Häggloader 10HR-B
Tractive effort (4 wheel drive)	10 500 kp	10 500 kp
Bending force at the bucket tip	-	50 000 N
Steering	4 wheel	4 wheel
Max work gradient (uphill)	1:5 (20%)	1:5 (20%)
Max work gradient (downhill)	1:7 (14%)	1:7 (14%)
Loading capacity	Approx. 5 m <sup>3</sup> /min	Approx. 4 m <sup>3</sup> /min
Tires	12x20*	12x20*
Weight	21 900 kg	21 900 kg

### Transmission

Maximum travel speed	
Electric	3 km/h
Diesel	12 km/h

### Options

	Häggloader 10HR	Häggloader 10HR-B
Quick tool	-	○
Scaling hook for bucket	-	○
Hydraulic breaker	-	○
Electrical cable	○	○
Fire suppression system	○	○
Extended conveyor	○	○
Water hose reel	○	○
Sliding attachment	-	○

### Safety

- Spring applied hydraulically released parking and emergency brake (SAHR)
- FOPS certified operator's cabin with heat- and air conditioning system
- Two rear-mounted cameras for maximum visibility
- Oil-free operator environment
- Door interlock (blocks boom movements when door opens)

### Comfort

- Ergonomic multifunction control joysticks
- Great visibility from cabin
- Air condition and heating system
- Multifunction display with intuitive operator interface

### Sustainability

- Hybrid technology provides operation on both diesel and electrics
- The electro-hydraulic drive means low ventilation demand and improved working environment

- The chassis and conveyor are made of heavy duty steel plate welded in a continuous process to ensure maximum fatigue strength
- Hydraulic cylinders with internal and external damping to extend lifetime and minimize vibrations for operator

### Productivity

- The conveyor can be raised and lowered to suit the loading height of different haulage vehicles
- The dozer blades clean the floor effectively, thus eliminating the need for manual clean up
- Two different boom options – dual digging arms or backhoe. The dual digging arms provide high productivity and loading capacity. The backhoe is multi-functional, flexible and can also perform digging and scaling
- A built-in sprinkler system controls dust effectively
- Open type conveyor in combination with wide digging arm bridge allows large rocks to pass through
- Load sensing variable displacement hydraulic pump for reduced energy consumption

# Technical specifications

## Hägglöader 10HR

Side view

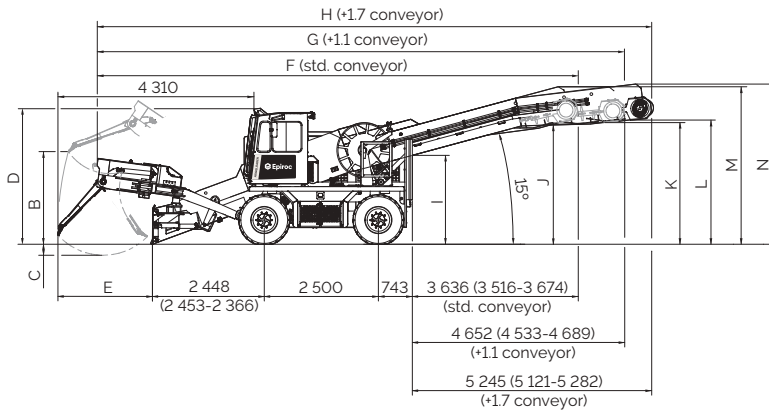

Front view

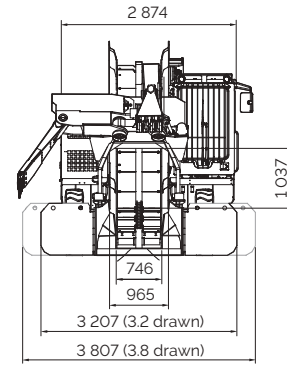

Turning radius

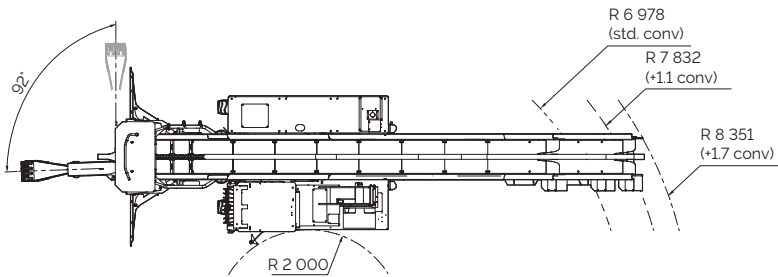

### Dimensions

Height (mm), B	2 351
Digging depth (mm), C	198
Tramming height (mm), D	2 977
Reach (mm), E	2 088
Total length tramming, std conv. (mm), F	10 723
Total length tramming, +1.1 conv. (mm), G	11 732
Total length tramming, +1.7 conv. (mm), H	12 328
Height between conv. and ground (mm), I	1 948 (1 850-2 327)
Height between conv. and ground, std conv (mm), J	2 654 (2 514-3 223)
Height between conv. and ground, ext 11 m conv (mm), K	2 663 (2 508-3 296)
Height between conv. and ground, ext 17 m conv (mm), L	3 507 (3 341-4 184)
Height between conv. and ground, std and ext 11 m (mm), M	3 449 (3 308-4 015)
Height between conv. and ground, std and ext 17 m (mm), N	3 507 (3 341-4 184)

## Hägglöader 10HR-B

Side view

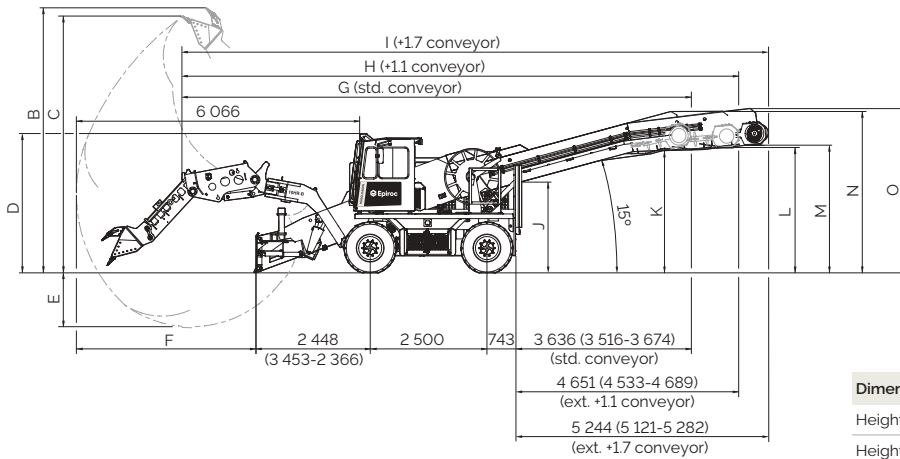

Front view

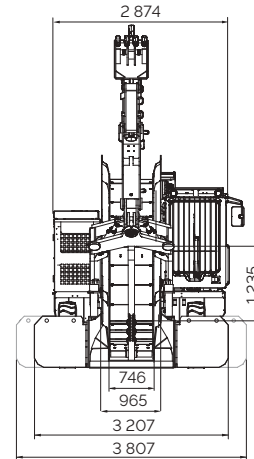

Turning radius

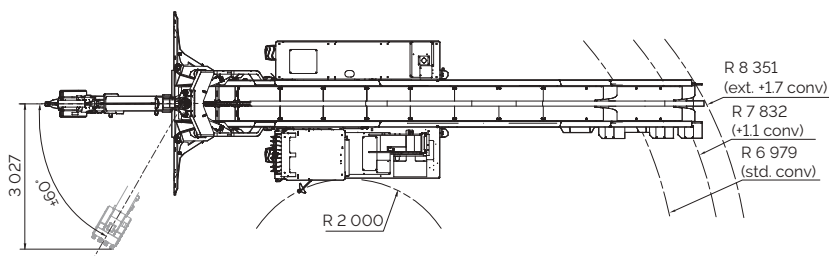

### Dimensions

Height (mm), B	5 673
Height (mm), C	5 494
Tramming height (mm), D	2 977
Digging depth (mm), E	1 153
Reach (mm), F	3 844
Total length tramming, std conv. (mm), G	11 209
Total length tramming, +1.1 conv. (mm), H	12 209
Total length +1.7 conv. (mm), I	12 803
Height between conv. and ground (mm), J	1 945 (1 850-2 327)
Height between conv. and ground, std conv (mm), K	2 654 (2 514-3 223)
Height between conv. and ground, ext 11 m conv (mm), L	2 663 (2 508-3 296)
Height between conv. and ground, ext 17 m conv (mm), M	2 720 (2 555-3 391)
Height between conv. and ground, std and ext 11 m (mm), N	3 448 (3 308-4 015)
Height between conv. and ground, std and ext 17 m (mm), O	3 507 (3 341-4 184)

9869 0017 01 2018-04 Örebro, Sweden. Legal Notice © Copyright 2018, Epiroc. All rights reserved. Epiroc, Örebro, Sweden. Any unauthorized use or copying of the contents or any part thereof is prohibited. Illustrations and photos may show equipment with optional extras. No warranty is made regarding specifications on otherwise. Specifications and equipment are subject to change without notice. Consult your Epiroc Customer Center for specific information.

## United in performance. Inspired by innovation.

Performance unites us, innovation inspires us, and commitment drives us to keep moving forward. Count on Epiroc to deliver the solutions you need to succeed today and the technology to lead tomorrow.  
**[epiroc.com](https://epiroc.com)**



<https://tractormanualz.com/>