

# Scooptram ST1030

Underground loader with 10-tonne capacity



# Superior underground mucking

The scooptram ST1030 is a reliable 10 tonnes underground loader with an ergonomically designed operator compartment for unparalleled productivity in mid-size mining applications

## ⊕ Main benefits

**Safety first** when the Scooptram ST1030 has been designed with safety in focus, with many standard features to secure your operation

**Excellent comfort** thanks to the first-class working environment in any surroundings in the Scooptram's air-conditioned, roomy cab

**Maximum productivity** in the Scooptram ST1030 because of the combination of proven drive train components and a compact frame





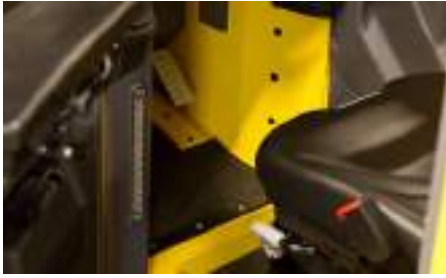

Epiroc's unique footbox design guarantees maximum comfort and natural driving position to get the unbeatable productivity.



The patented GET system (Ground Engaging Tool) optimizes muck pile penetration and reduces fuel consumption while achieving one-pass loading with low operating cost.



The unique boom and bucket design combined with an automatic de-clutch are key features to achieve easy mucking for production or mine development.

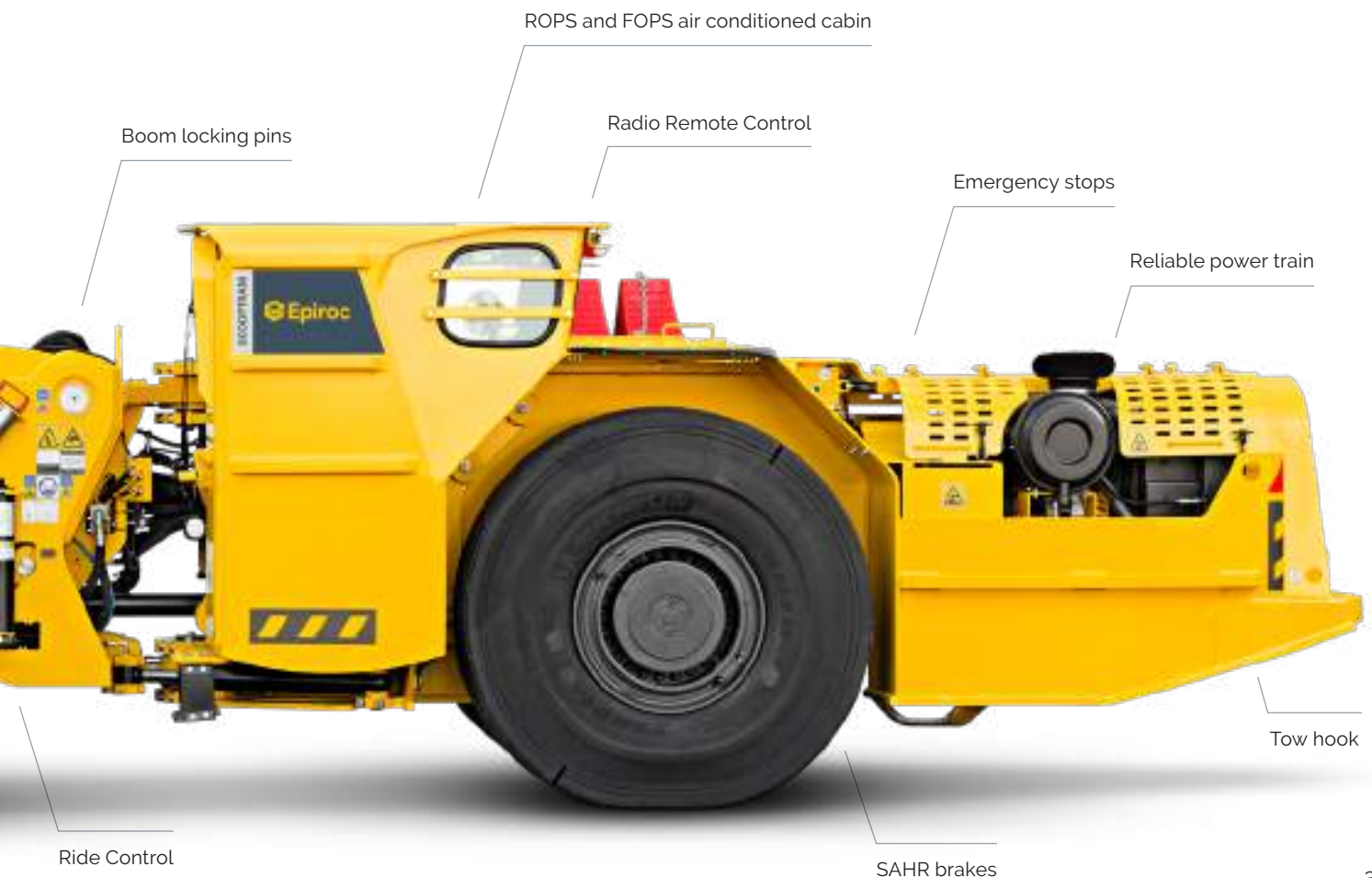

## Features

### Safety

- Spring-applied, hydraulic release (SAHR) brakes
- ISO ROPS and FOPS certified operator compartment with door interlock (when cabin door is opened, the brakes are applied and steering and bucket/boom movement are blocked)
- Great operator visibility
- Locking pins for center hinge and boom
- Three strategically located emergency stops
- Front and rear cameras

### Comfort

- Epiroc footbox to expand leg room
- Rubber-mounted cab to reduce vibration and noise
- Ride control boom suspension keeps the bucket stable while tramming and offers smoother ride
- Ergonomic joysticks
- Comfortable air suspended seat

### Sustainability

- Automatic de-clutch to simplify and speed up dumping operation, reduce fuel consumption and increase components service life, especially when loading into trucks
- Durable power-train components
- Fuel-efficient, clean-burning EPA Tier 3/EU Stage IIIA engine
- Rock-tough catalytic purifier
- L and M V-tube core radiator

### Productivity

- Ride control to provide a smooth ride, allowing to travel at higher speed and reducing spillage
- Load weighing system

### Serviceability

- Easy maintenance with centrally located service point
- Anti-skid materials at service access points
- Central lubrication

## Specifications

Capacities	
Tramming capacity*	10 000 kg
Breakout force, hydraulic	17 900 kg
Breakout force, mechanical	13 900 kg
*Tramming capacity with EOD bucket 9 000 kg	
Motion times	
Boom raising	8.0 sec
Boom lowering	6.0 sec
Dumping	2.1 sec
Weights (standard empty vehicle)	
Approximate weight	27 200 kg
Axle load, front end	13 700 kg
Axle load, rear end	13 500 kg

## Engine

	Standard	Alternative *
Brand/model: Cummins QSL9	EPA Tier 3/EU Stage IIIA	Tier 4 Interim/EU stage IIIB
Power rating at 2 000 rpm	186 kW/250 hp	198 kW/265 hp
Maximum torque at 1 400 rpm	1 085 Nm	1 085 Nm
MSHA Part 7 ventilation rate	255 m <sup>3</sup> /min	297 m <sup>3</sup> /min
MSHA Part 7 particulate index	340 m <sup>3</sup> /min	14 m <sup>3</sup> /min

**Standard:** Dry type air filter, catalytic purifier and silencer, exhaust heat protection, cooling package with tube type radiator, remote engine oil and cooling fuel drain.

**Alternative:** Different engine, coolers, different aftertreatment system (dry type air filter with cyclone functionality)

\*Please note! Requires ultra low sulphur diesel and low ash engine oil.

## Fuel

Fuel tank capacity: 284 litres	●
Fuel filtration, primary, including water trap: 7 µm	●
Fuel filtration, secondary: 3 µm	●

## Transmission

Automatic power shift with integrated converter, fully modulated 4 speed shifting, forward/reverse with de-clutch function	●
Brand/model: Funk DF250	●

## Axles

Brand/model: Kessler D102	●
Degree of rear axle oscillation: 16° (8° on each side)	●
Differentials: front, limited slip	●
Differentials: rear, no spin	●

## Brakes

Fully enclosed, force-cooled, multiple wet discs at each wheel end	●
Service/parking/emergency brakes: SAHR	●
Brake apply after 3 sec in neutral	○
Brake release retriever tow hook	○

## Tires

Tubeless tire design for underground mine service	●
Tire size front and rear: 18.0OR25 (slicks)	○
Tire size front and rear: 18.0OR25 (treaded)	○

\*As applications and conditions vary, Epiroc recommends that the user consults with tire suppliers to obtain the optimum tire selection.



## Operator's compartment

Canopy (ISO ROPS and FOPS)	●
Cabin with automatic climate control, pressurized with filtered air (ISO ROPS and FOPS)	○
Door interlock (applies brakes, blocks steering and bucket/boom movement when door opens)	●
Open door retainer	●
Side seated operator for bi-directional operation	●
Air suspension seat with 2-point retractable seat belt	●
External sound level according to ISO 6393 LwA 126 dB(A)	
Sound level in canopy acc. to ISO 6394 LpA 101 dB(A)	
Sound level in cabin according to ISO 6394 LpA 85 dB(A)	
Whole body vibration value according to below EN 14253 A(8)w maximum 0.5–2.0 m/s <sup>2</sup>	

## Hydraulic system

Heavy duty gear type pumps	●
System pressure 21.4 MPa	●
Hydraulic tank capacity 189 litres	●
Filtration, return line: 12 µm	●
Electric pump for hydraulic tank fill, 24 V	○
Arctic oil	○
Steering cylinders: chrome plated stems, 2x90 mm diameter	
Hoist cylinders: chrome plated stems, 2x160 mm diameter	
Stabilizer cylinder: chrome plated stems, 1x200 mm diameter	

## Control system

Front and rear cameras	○
Audio-visual reverse alarm	●
Joystick controls for dump and hoist and steering	●
Bucket float	●
Ride control (boom suspension)	○

## Electrical system

System voltage: start and accessories, 24/12V converter	●
Mine duty high output alternator: 140 Amps	●
Isolation switch lockout	●
Driving lights LED: 13x40 W	●
Detachable service light (required for CE certified vehicles)	○

## Main frame

Center hinge and boom lock up pins	●
EOD ejector bucket	○
Side tipping bucket	○
Ground engagement tools	○
Wheel chocks and brackets	○
Knockdown construction	○
Central manual lubrication system	●
Central automatic lubrication system	○
Wiggins fast fuel fill	○
Wiggins fast hydraulic oil fill	○
Hand held fire extinguisher	○
Ansul manually activated fire suppression system with engine shut down	○
Ansul checkfire automatically activated fire suppression system	○
Cold weather package 120 V or 240 V: block heater, battery warmer, fuel heater, hydraulic oil heater, transmission oil heater, arctic oil	○
Corrosion resistant radiator	○

## Automation

Scooptram Radio Remote Control interface	○
Scooptram Radio Remote Control	○
Certiq telematics solution professional	○

## Parts and services

Preventive maintenance kits	○
Repair and rebuild kits	○
Upgrade kits	○
Face mechanics tool set	○
Shop mechanics tool set	○
Operators training in simulator	○

## Documentation

Operator, service and spare parts manual on CD and hard copy	●
Plasticized parts and service manuals	○

# Technical specifications

## Grade performance

Standard configuration, empty bucket													
%	Grade	0.0	2.0	4.0	6.0	8.0	10.0	12.5	14.3	16.0	18.0	20.0	25.0
Ratio	Grade	-	-	-	-	1:12	1:10	1:8	1:7	-	-	1:5	1:4
Km/h	1st gear	5.0	4.8	4.8	4.7	4.6	4.5	4.4	4.3	4.2	4.1	4.1	3.9
	2nd gear	8.9	8.5	8.3	8.0	7.8	7.6	7.1	6.8	6.5	6.2	5.8	4.7
	3rd gear	15.8	14.7	13.8	12.8	11.6	10.2	7.9	5.9	4.4	-	-	-
	4th gear	26.7	23.3	18.9	12.7	-	-	-	-	-	-	-	-

3% rolling resistance assumed. Actual performance may vary depending on the application. Continuous operation is recommended on maximum 1:7 grade.

## Grade performance

Standard configuration, loaded bucket													
%	Grade	0.0	2.0	4.0	6.0	8.0	10.0	12.5	14.3	16.0	18.0	20.0	25.0
Ratio	Grade	-	-	-	-	1:12	1:10	1:8	1:7	-	-	1:5	1:4
Km/h	1st gear	4.9	4.8	4.8	4.8	4.4	4.3	4.2	4.1	4.0	3.9	3.7	3.4
	2nd gear	8.7	8.3	7.9	7.6	7.2	6.7	6.1	5.4	5.1	4.1	3.3	-
	3rd gear	15.1	13.9	12.4	10.6	8.2	-	-	-	-	-	-	-
	4th gear	24.9	19.1	-	-	-	-	-	-	-	-	-	-

3% rolling resistance assumed. Actual performance may vary depending on the application. Continuous operation is recommended on maximum 1:7 grade.



# Technical specifications

## Measurements and weights

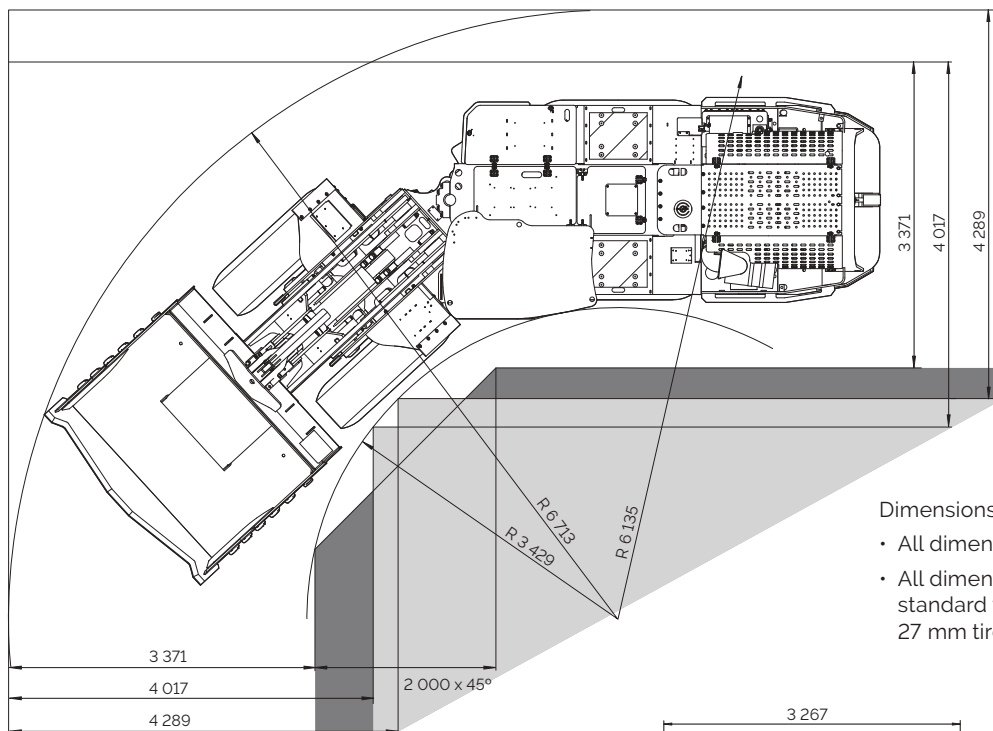

Turning radius

### Dimensions

- All dimensions are shown in millimetres
- All dimensions shown are based on standard vehicle configuration with 27 mm tire deflection, unloaded

Side view

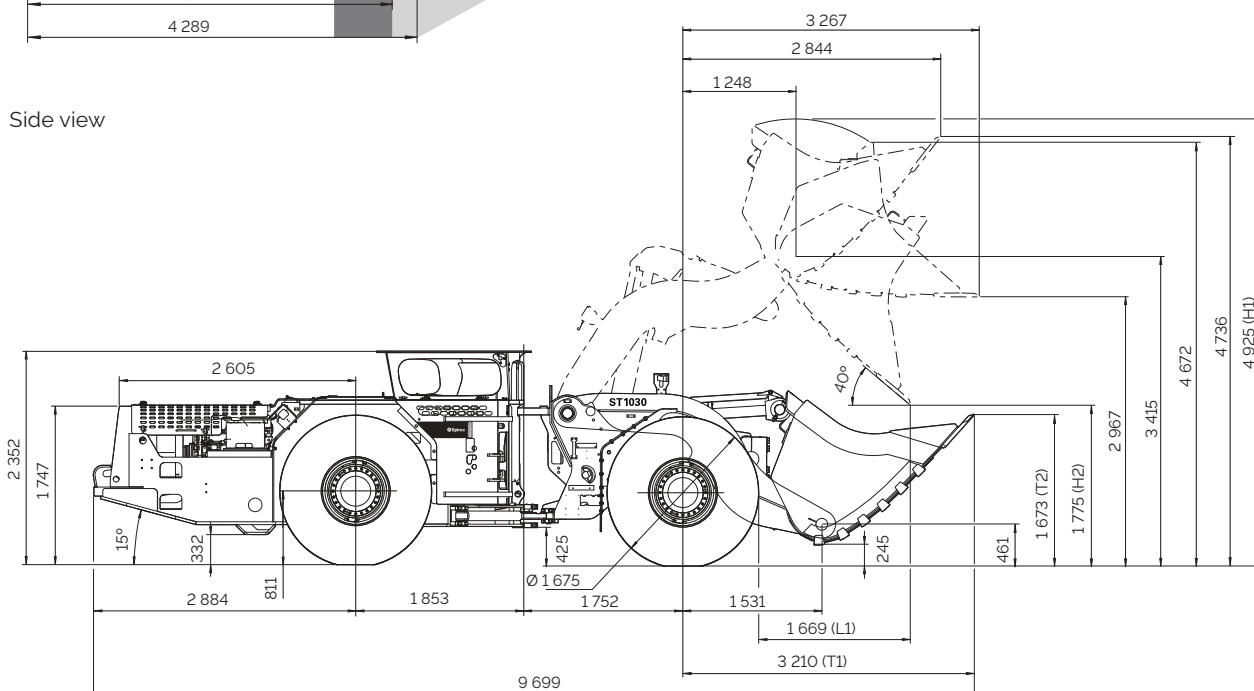

## Bucket data

		STANDARD						EOD					
			STD										
Volume, nominal heaped (m3)		5.0	4.5	4.2	3.8	3.6	3.3	4.5	4.2	3.8	3.6	3.3	3.0
Maximum material density (t/m3)		2.0	2.2	2.4	2.6	2.8	3.0	2.0	2.2	2.4	2.6	2.8	3.0
Width, bucket (mm)	W	2 488	2 488	2 488	2 488	2 488	2 490	2 548	2 548	2 548	2 548	2 548	2 548
Tramming position: axle centre line to bucket lip (mm)	T1	3 268	3 204	3 155	3 098	3 054	3 014	3 379	3 285	3 249	3 170	3 113	3 079
Tramming position: ground bucket tip (mm)	T2	1 726	1 663	1 614	1 558	1 515	1 475	1 890	1 770	1 725	1 645	1 585	1 549
Reach dimension (mm)	L1	1 734	1 662	1 610	1 547	1 500	1 456	1 821	1 774	1 735	1 646	1 585	1 548
Raised position: back height, max (mm)	H1	4 917	4 910	4 895	4 907	4 878	4 879	4 958	4 942	4 858	4 795	4 764	4 743
Raised position: bucket tip, height (mm)	H2	1 708	1 765	1 811	1 863	1 903	1 940	1 677	1 703	1 738	1 814	1 869	1 903



## United in performance. Inspired by innovation.

Performance unites us, innovation inspires us, and commitment drives us to keep moving forward. Count on Epiroc to deliver the solutions you need to succeed today and the technology to lead tomorrow.  
**[epiroc.com](https://epiroc.com)**

