

### 444J-624J START CIRCUIT

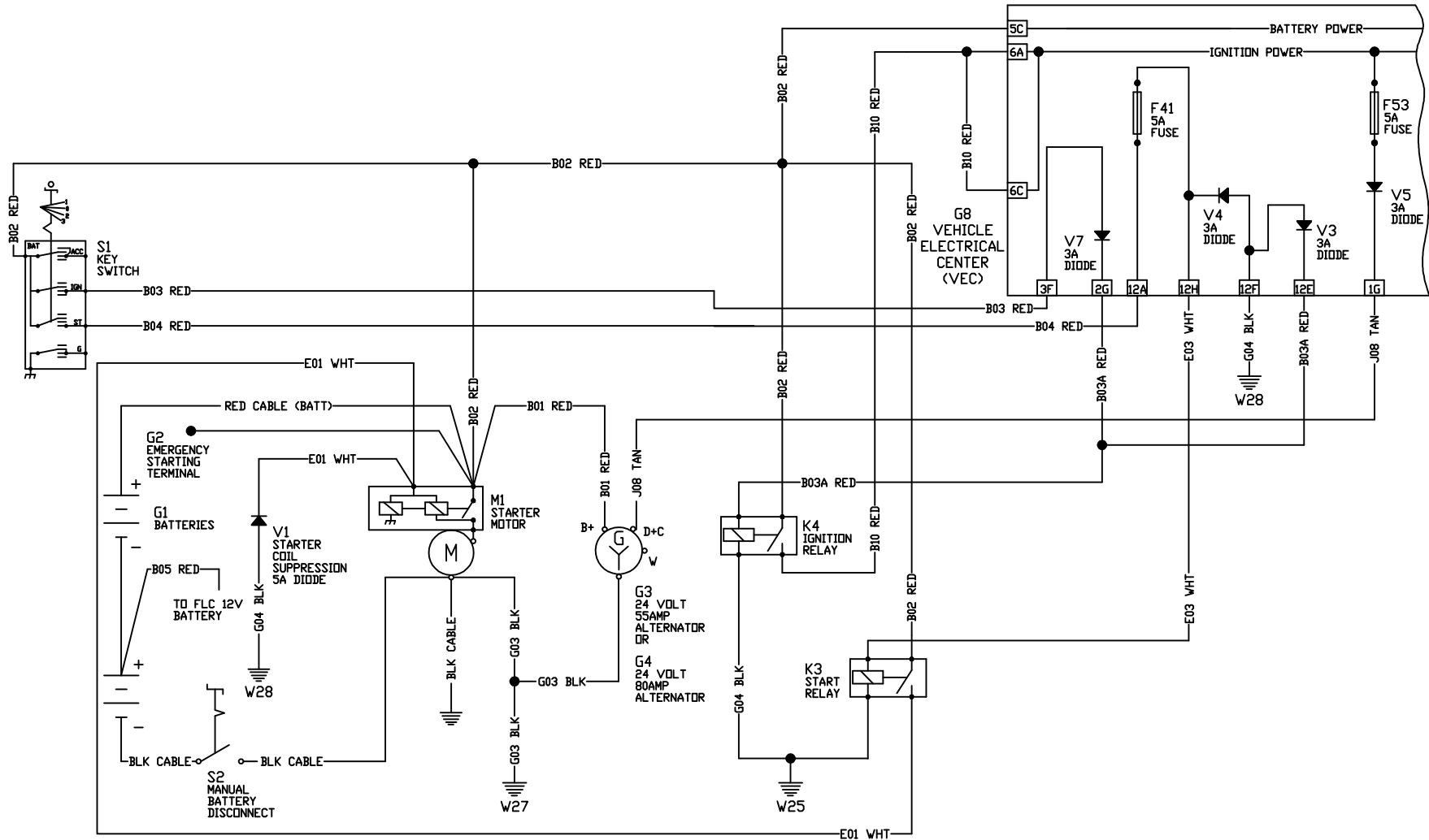

T193463

IMPORTANT: Documents should only be used for training purposes. Always use the schematics out of the technical manual when diagnosing a machine.

### 444J-624J FLEX LOAD CONTROLLER (FLC) CIRCUIT

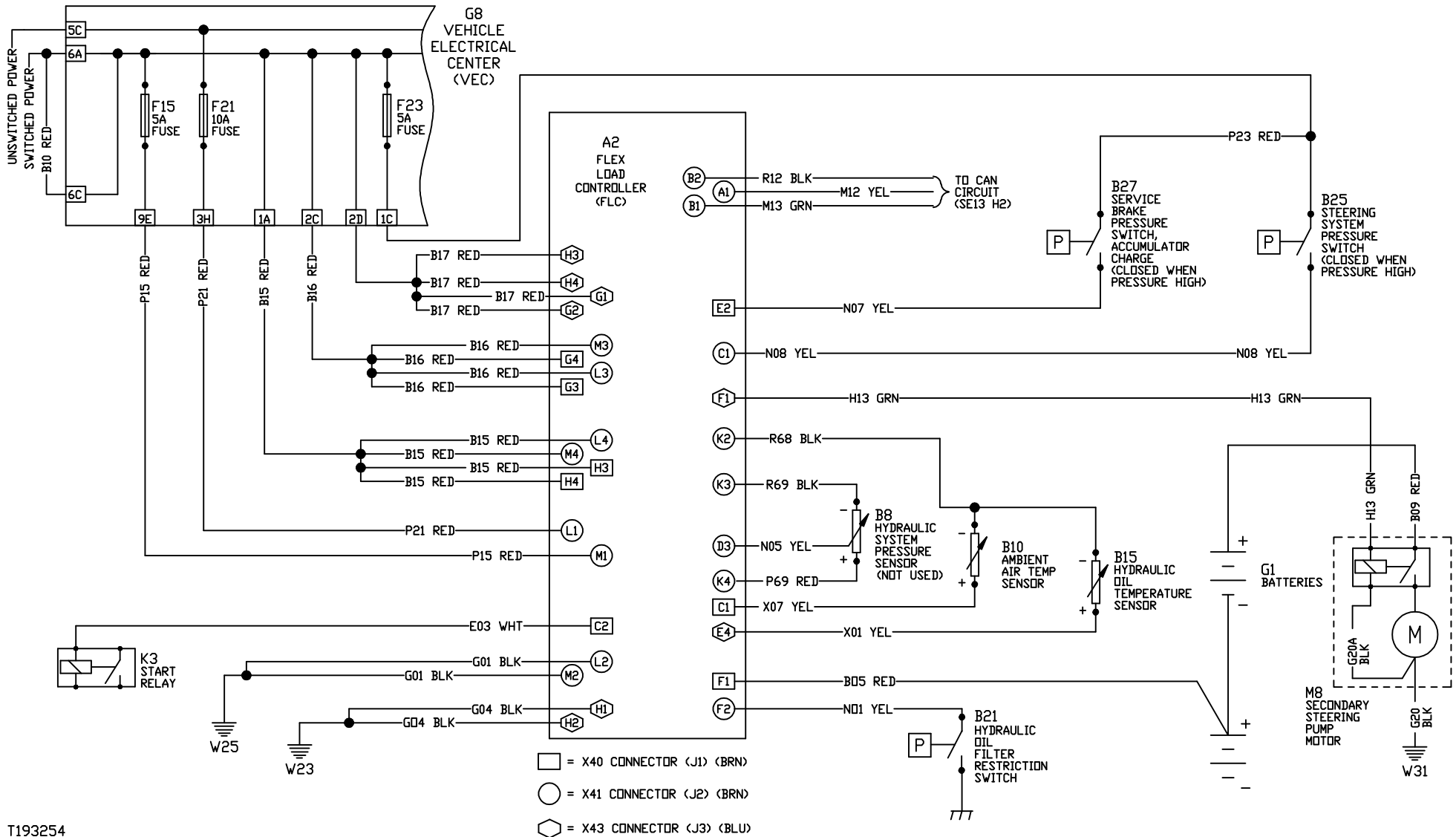

T193254

**IMPORTANT:** Documents should only be used for training purposes. Always use the schematics out of the technical manual when diagnosing a machine.

### 444J-624J SYSTEM FUNCTIONAL SCHEMATIC

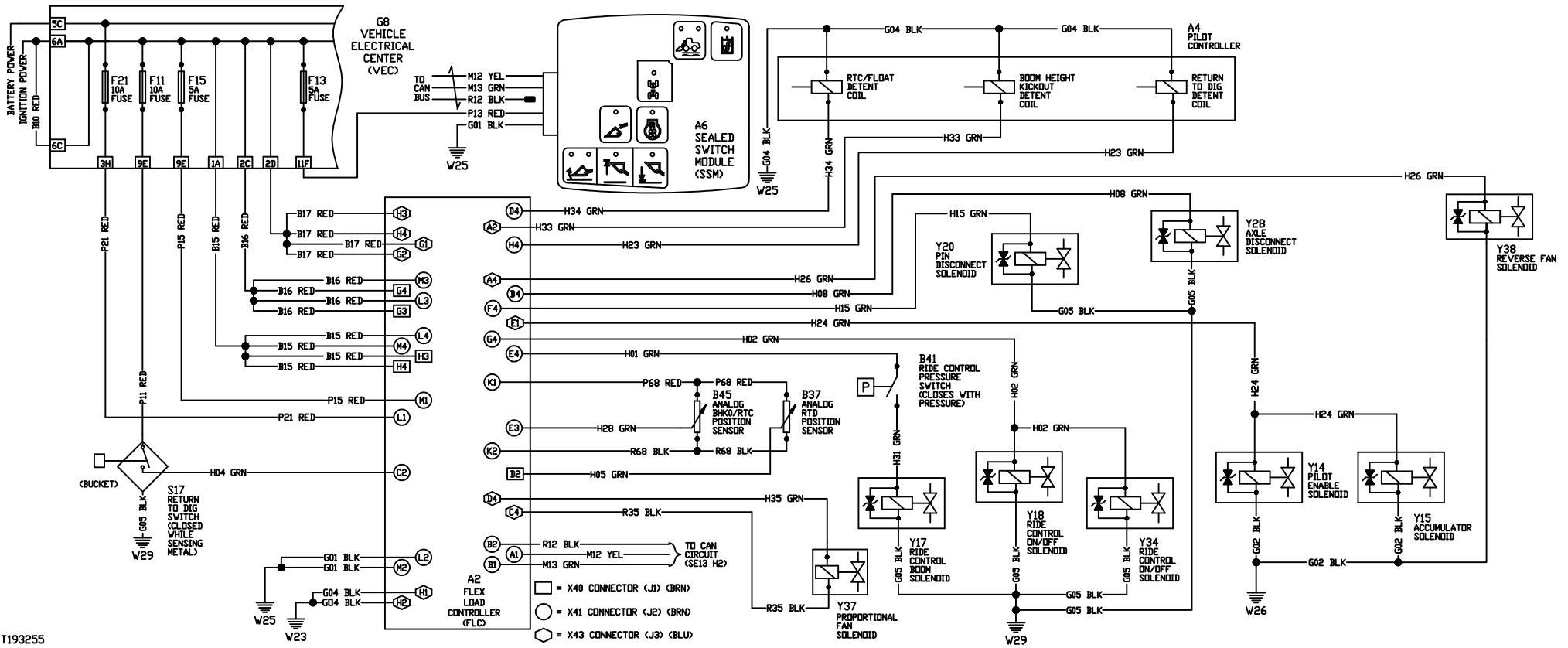

T193255

IMPORTANT: Documents should only be used for training purposes. Always use the schematics out of the technical manual when diagnosing a machine.

### 444J-624J ECU CIRCUIT

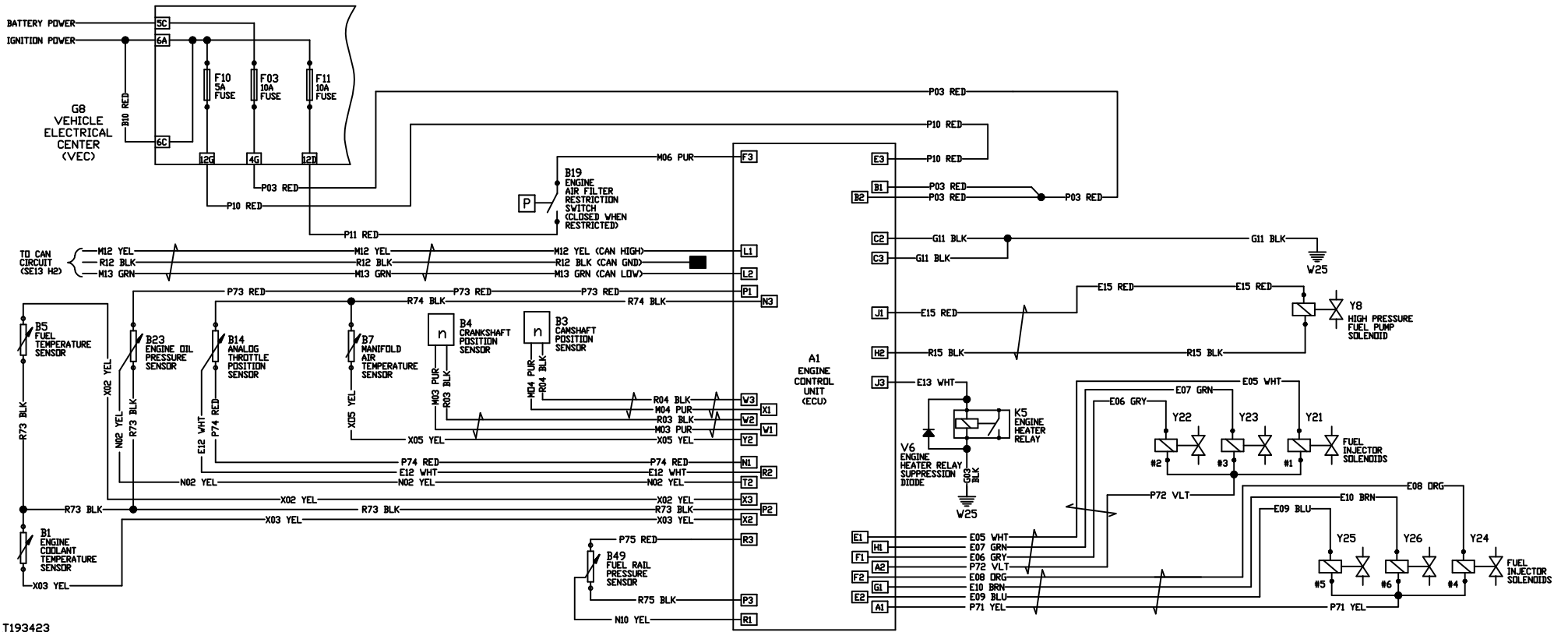

T193423

IMPORTANT: Documents should only be used for training purposes. Always use the schematics out of the technical manual when diagnosing a machine.

### 444J-624J TCU CIRCUIT

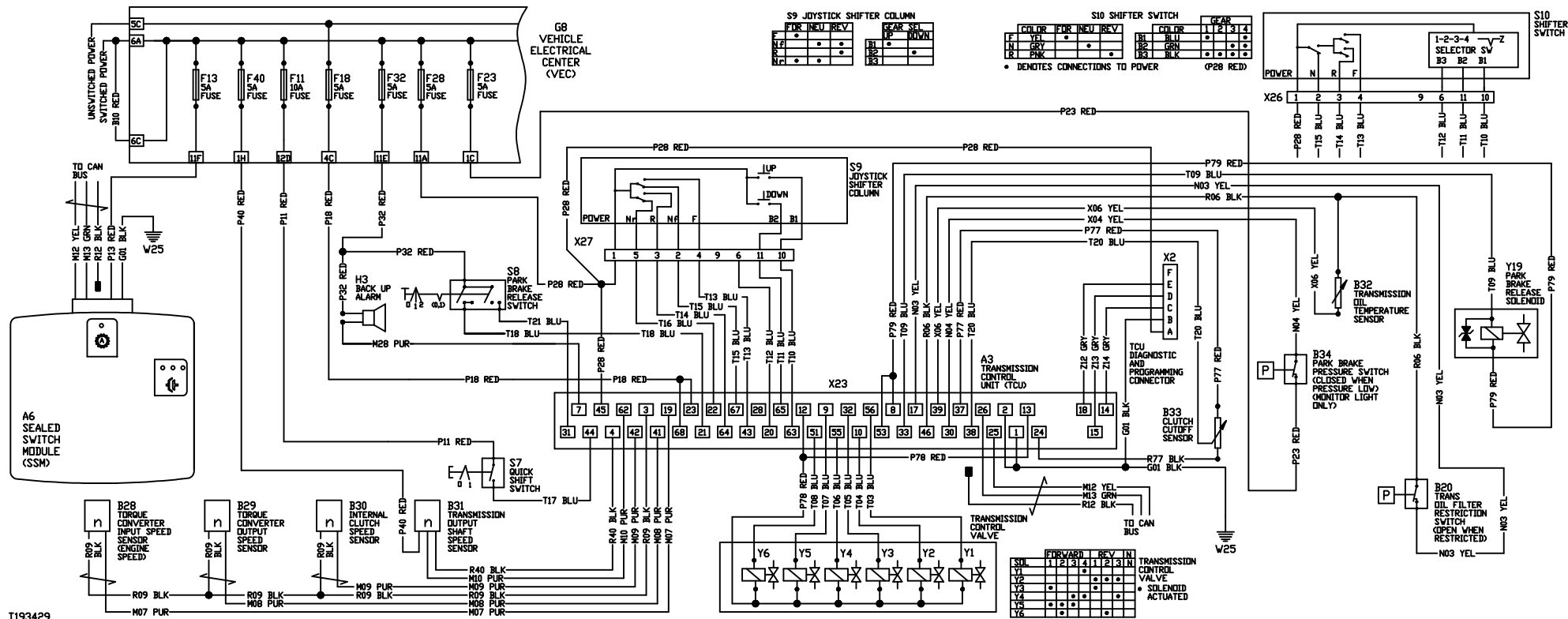

T193429