



1260
Hoftrac



Technical specifications

	Standard	Outfitting example 1	Outfitting example 2
Engine data			
Manufacturer	Perkins	Perkins	Perkins
Engine type	404 D-15	404 D-15	404 D-15
Cylinders	4	4	4
Engine performance (max.) kW (hp)	24.6 (33)	24.6 (33)	24.6 (33)
at rpm (max.) rpm	2,800	2,800	2,800
Cubic capacity cm ³	1,508	1,508	1,508
Cooling system	Water	Water	Water
Engine data			
Electric motor			
Battery Standard			



	Standard	Outfitting example 1	Outfitting example 2
Battery Optional			
Electrical system			
Operating voltage V	12	12	12
Battery Ah	77	77	77
Alternator A	65	65	65
Weights			
Operating weight (standard) kg	2,080	2,170	2,290
Lift force (max.) daN	2,473	2,473	2,473
Tipping load with bucket - machine straight kg	1,018	1,057 / 1,357*	1,118 / 1,389*
Tipping load with bucket - machine articulated kg	766	827 / 1,032*	861 / 1,078*
Tipping load with pallet fork - machine straight kg	831	871 / 1,122*	919 / 1,136*
Tipping load with pallet fork - machine articulated kg	622	675 / 857*	714 / 892*
Vehicle data			
Axle (optional)	K80 (K90, T80, T94)	T80	T94
Cab (optional)	FSD (eps)	FSD (eps)	FSD (eps)
Ground speed (optional) km/h	0 - 13 (20, 30)	0 - 20	0 - 20 (30*)
Speed stages (optional)	1 (2*)	2	2
Fuel tank capacity l	40	40	40
Hydraulic oil tank capacity l	27	27	27
Hydraulic system			
External services - Operating pressure bar	305	330	330
Steering hydraulics - Oil flow l/min	44.8	44.8	44.8
Steering hydraulics - Operating pressure bar	185	185	185
Drive			
Type of drive	Hydrostatic	Hydrostatic	Hydrostatic
Traction drive	Oil engine	Universal joint shaft	Universal joint shaft

*Tipping load with counterweight (base plate and cast rear weight)

Tipping load calculation according to ISO 14397

FSD = canopy

eps = Easy Protection System (fold-down canopy)



Vibrations (weighted average effective value)

Hand-arm vibrations: The hand-arm vibrations are no more than 2.5 m/s²

Whole body vibrations: This machine is equipped with a driver's seat that meets the requirements of EN ISO 7096:2000.

When the loader is properly used, the whole body vibrations vary from below 0.5 m/s² up to a short-term maximum value.

It is recommended to use the values specified in the table when calculating the vibration values according to ISO/TR 25398:2006. At the same time the actual use conditions have to be taken into consideration.

Telescopic loaders, like wheel loaders, are to be classified by operating weight.

Type of loader	Typical operating conditions	Average value			Standard deviation (s)		
		1.4*a _{w,eqx}	1.4*a _{w,eqy}	a _{w,eqz}	1.4*s _x	1.4*s _y	s _z
		[m/s ²]	[m/s ²]	[m/s ²]	[m/s ²]	[m/s ²]	[m/s ²]
Compact wheel loader (operating weight < 4,500 kg)	Load & carry (load and transport work)	0.94	0.86	0.65	0.27	0.29	0.13
Wheel loader (operating weight > 4,500 kg)	Load & carry (load and transport work)	0.84	0.81	0.52	0.23	0.2	0.14
	Application in extraction (harsh application conditions)	1.27	0.97	0.81	0.47	0.31	0.47
	Transfer drive	0.76	0.91	0.49	0.33	0.35	0.17
	V-operation	0.99	0.84	0.54	0.29	0.32	0.14



1260
Hoftrac

Dimensions

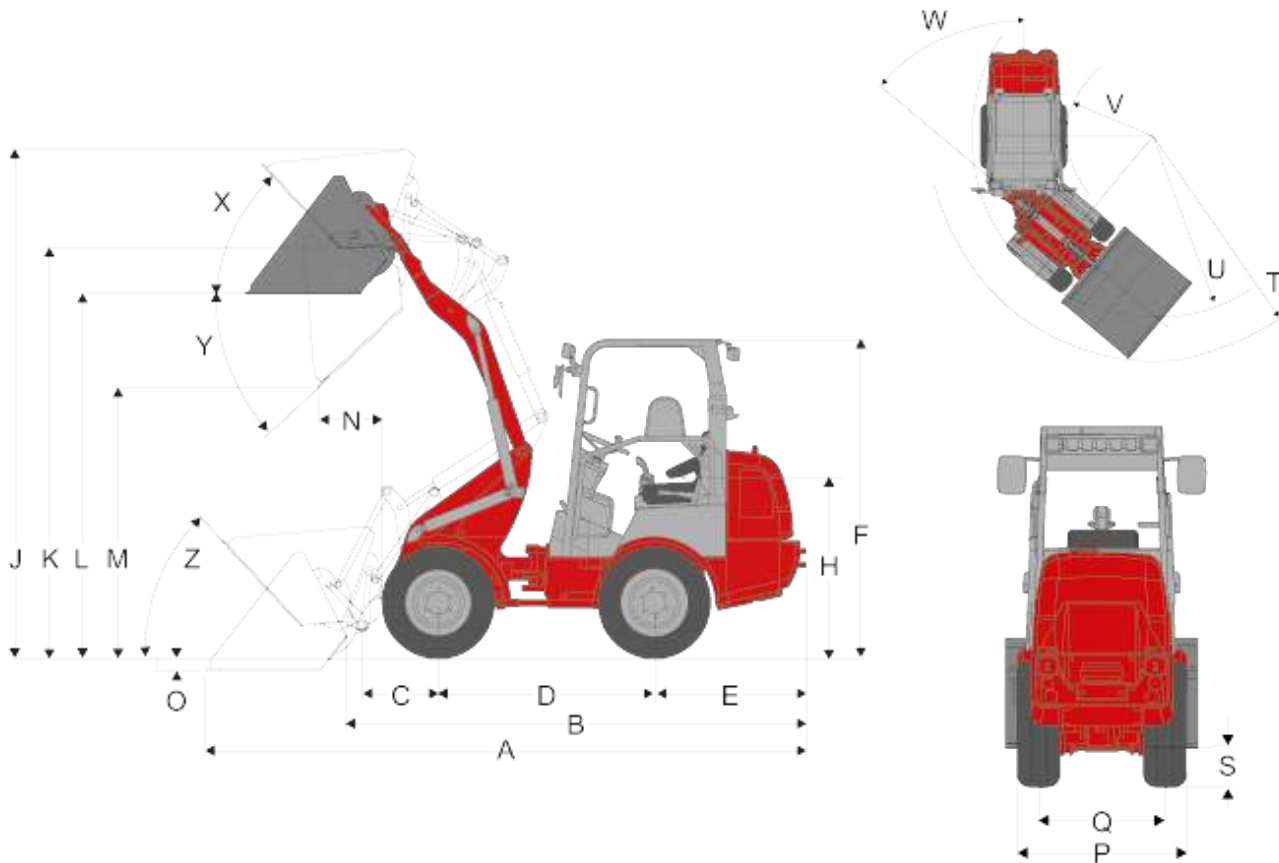

Standard tyres 27 x 8.50 - 15 EM ET30

A	Total length	4,127 mm
B	Total length (without bucket)	3,151 mm
C	Axle middle to bucket pivot pin	531 mm
D	Wheelbase	1,503 mm
E	Rear overhang	1,000 mm
F	Height to top of overhead guard fixed	2,156 mm
	Height to top of overhead guard foldable (eps)	2,260 mm
	Height to top of overhead guard foldable, folded (eps)	1,846 mm



H	Seat top height	1,190 mm
J	Total working height	3,473 mm
K	Height of bucket pivot (max.)	2,788 mm
L	Load-over height	2,469 mm
M	Dumping height	1,812 mm
N	Operating distance for M	499 mm
O	Digging depth	153 mm
P	Total width	970 mm
Q	Track width	752 mm
S	Ground clearance	199 mm
T	Maximum radius external	2,648 mm
U	Radius at the outer edge	2,203 mm
V	Inside turning radius	1,083 mm
W	Inclination angle	50 °
X	Rollback angle at max. lifting height	47 °
Y	Dumping angle (max.) (max.)	43 °
Z	Rollback angle (on the ground)	47 °

eps (Easy Protection System) = fold-down canopy

**1260**

Hoftrac

Standard features**Engine**

- Perkins 404 D-15 (24.6 kW / 33 hp)

Drive

- Compact axle K80
- Automatic drive via oil engines on the axles, travel direction can be selected via the joystick
- Service brake: Hydrostatic drive system acting on all 4 wheels (wear-free)
- Central service and parking brake in the drive train acting on all 4 wheels
- Tyres 27 x 8.50 - 15 EM ET30

Steering

- Hydraulic articulated pendulum steering, 12° oscillating angle

Hydraulics

- 3rd Control circuit front DN10
- Hydraulic oil cooler
- Lock for steering valve
- Floating position for lift and tilting cylinders

Driver's cab

- Canopy with retaining system ROPS / FOPS tested, driver's cab can be tilted to the side
- Comfort seat with safety belt, fully suspended, weight, back and horizontal adjustment, 60 mm spring deflection
- Joystick with travel direction switch

Other

- Working lights (2 front, 1 rear)
- Operating hour meter
- Battery circuit breaker
- Fuel display
- Mechanical quick-change system for attachments

**1260**

Hoftrac

Options

Driver's cab

- Right armrest
- eps (Easy Protection System) - fold-down canopy
- Adjustable steering column
- Air-suspended comfort seat

Lighting

- Working light on loading arm
- Lighting according to Road Traffic Regulations
- Rotary beacon

Axles / drive

- K90 (automatic drive via oil engines on the axles)
- T80, including transfer gear and universal joint shaft
- T94 including Transfer gear and universal joint shaft (medium or high pressure drive system)
- 100% differential lock (only for axle T80 and T94)
- Hand inching (creep speed controller)
- Wheel spacer (30 mm)
- Speed increase to 30 km/h

Hydraulics

- Unpressurised reflux (front / rear)
- 3rd control circuit front DN12
- 3rd comfort control circuit
- 4th comfort control circuit
- Faster plug-in connector (machine or attachment side)
- Notch for joystick (single / double)
- Hydraulic connection in rear (single-acting or dual-acting)
- Three-point rear tool holder

Electrical connections

- Plug receptacle in front, triple-pole (single or dual function)
- Plug receptacle for rear attachments, 7-pin

Other

- Engine pre-heating
- High lifting height
- Hydraulic quick-change system for attachments
- Counterweight (floor panel)
- Weight of cast iron rear
- Back-up alarm
- Load-lowering valve
- Combination case with warning triangle and first-aid kit
- Switch position indicator
- Self-recovery coupling



- Tool box
- Technical Inspection Authority expert's report
- Fully automatic central lubrication unit
- Custom made paint finish

Please note

that product availability can vary from country to country. It is possible that information / products may not be available in your country. Photos may depict options. Subject to change without notice. Errors and omissions are reserved. The contractual agreement is expressly decisive. More detailed information on engine power can be found in the operator's manual; the stated power may vary due to specific operating conditions.

Subject to alterations and errors excepted. Applicable also to illustrations.

Copyright © 2017 Weidemann GmbH.