

SECTION 6 - Electrical system

Always disconnect the battery before carrying out any work on the electrical system. **Before any welding operations, disconnect the battery and all the connectors of the electronic control units.**

Battery

Checking the battery



DANGER: BATTERIES PRODUCE EXPLOSIVE GASES. KEEP FLAMES, SPARKS AND SMOKING MATERIAL AWAY FROM BATTERIES. VENTILATION IS REQUIRED, WHEN CHARGING OR STORING BATTERIES. AVOID CONTACT BETWEEN ACID AND SKIN OR CLOTHES.

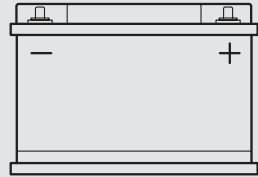

The battery is of the maintenance-free type
The electrolyte level should be between the minimum and maximum marks.
Check the battery charge level at the start of the winter season. Re-charge if necessary.



CAUTION: BEFORE CARRYING OUT ANY OPERATIONS, READ THE INSTRUCTIONS IN THIS MANUAL. FOLLOW THE INSTRUCTIONS CAREFULLY DURING OPERATION OF THE TRACTOR.



WARNING: BATTERY POSTS, TERMINALS AND RELATED ACCESSORIES CONTAIN LEAD AND LEAD COMPOUNDS, CHEMICALS KNOWN TO THE STATE OF CALIFORNIA TO CAUSE CANCER AND BIRTH DEFECTS OR OTHER REPRODUCTIVE HARM. WASH HANDS AFTER HANDLING.

To remove the battery from the tractor, proceed as follows:

The battery is located in a compartment behind the driver's seat.

- 1 - To access the battery, loosen the four knobs securing the cover and lift the cover upwards.
- 2 - Disconnect the earth lead from the negative terminal first and then disconnect the lead from the positive terminal.
- 3 - Loosen the 2 screws securing the battery retaining brackets and remove the battery from the support.

The terminal clamps must be kept clean and preferably coated with vaseline.

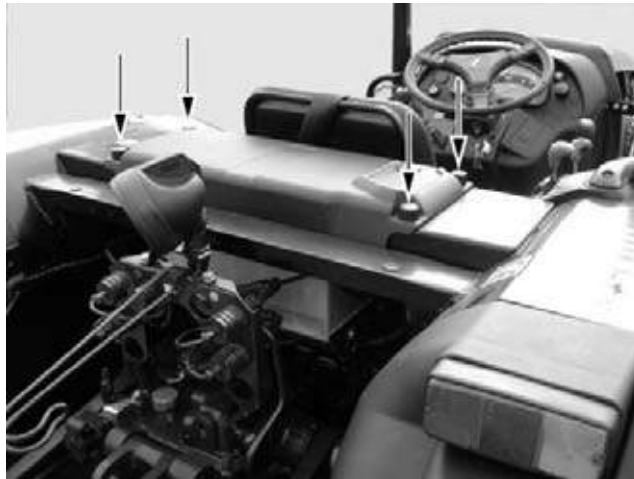

When refitting the battery, always connect the positive lead first and then the earth lead.

Important: Check frequently that the battery is securely anchored to its support.



WARNING: CONNECT ONLY TO A 12 VOLT SUPPLY TO BOOST BATTERY.



DANGER: TAKE CARE NOT TO CAUSE DANGEROUS SPARKS WHEN WORKING IN PROXIMITY TO FUEL DEPOSITS OR OTHER FLAMMABLE MATERIAL.



CAUTION: DISCONNECT THE BATTERY CABLES, BEFORE TO VERIFY OR REPAIR THE ELECTRICAL WIRING OR BEFORE TO START WELDING OPERATIONS ON TRACTOR OR ON ATTACHED IMPLEMENTS.

Diagnostic socket

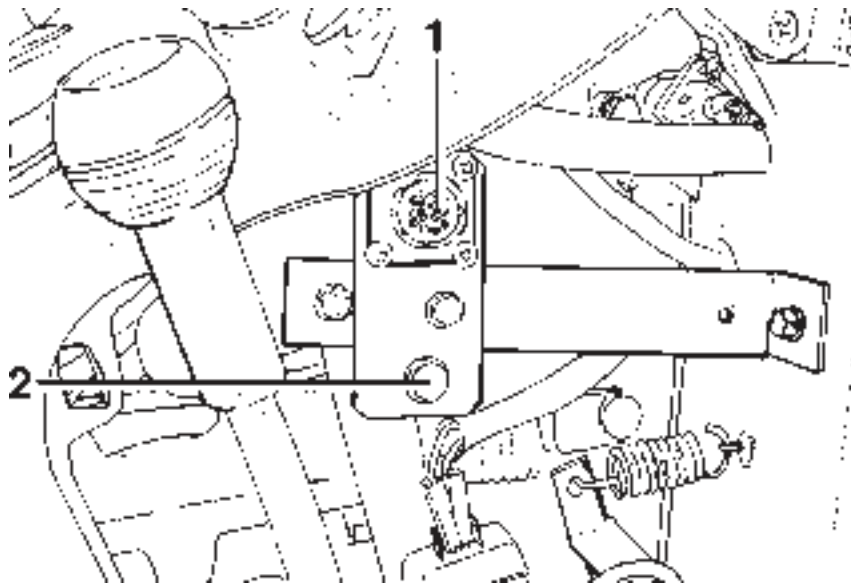

- 1 - Diagnostic socket
- 2 - Tyre selection pushbutton (see page 32)

Tractors with electronic engine governor are equipped with a diagnostic socket located on the right of the instrument panel.

To access the socket, remove the cover on the right of the instrument panel.

Position of the fuse holder box

The electrical system is protected by fuses which are grouped in a plastic fusebox positioned to the left of the dashboard.

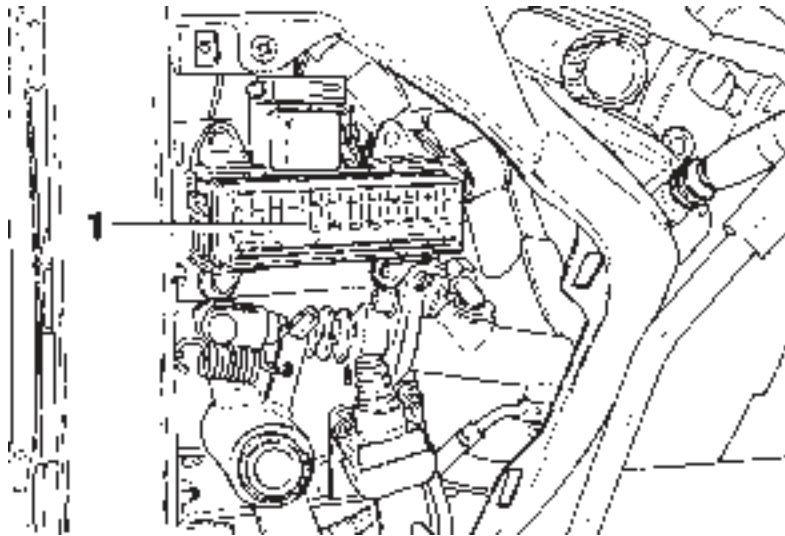

1 - Fuse and relay box

To access, remove the panel on the left-hand side of the instrument panel.

Should any component of the electrical system fail to function, check the corresponding fuse and replace it as necessary. In the event of a sudden breakdown, temporarily replace a fuse covering an important function (e.g. a headlight) by another of less importance. Always switch off the ignition and all electrical equipment before changing a fuse or a relay.

NOTE: Always switch off the engine before checking or replacing fuses and relays.

NOTE: Only use original fuses. The electrical system could be irreparably damaged by fitting an unsuitable fuse.

Fuse box layout

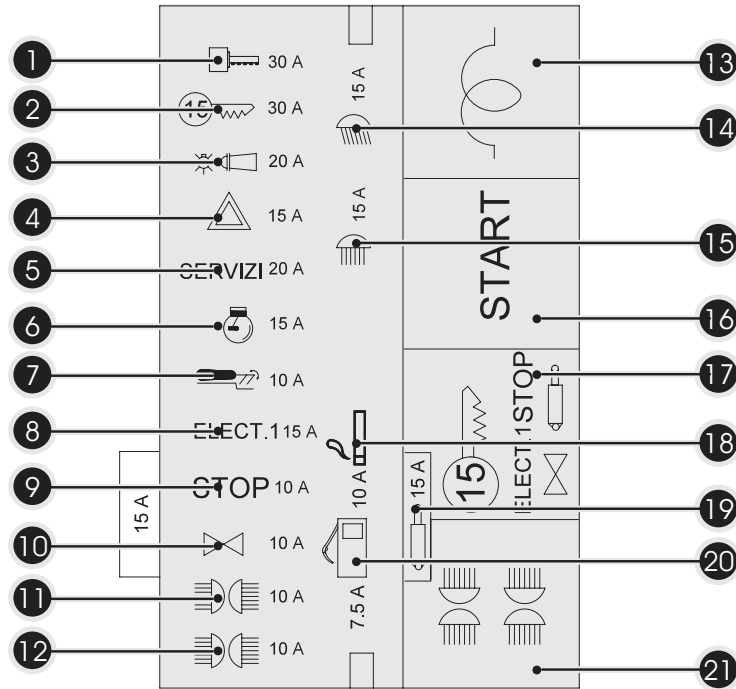

Fuse box

- | | |
|------------------------------------------|-------------------------------|
| 1 - Starter keyswitch | 2 - Relay (starter keyswitch) |
| 3 - Steering column switch -lights input | 4 - Hazard |
| 5 - Services | 6 - Engine ECU |
| 7 - Electronic lift | 8 - Electronic devices |
| 9 - Brake lights | 10 - Direction indicators |
| 11 - Sidelights | 12 - Sidelights |
| 13 - Thermostart relay | 14 - Low beam headlights |
| 15 - High beam headlights | 16 - Starter relay |
| 17 - Starter keyswitch relay | 18 - Cigar lighter |
| 19 - Lift | 20 - Fuel reserve |
| 21 - Lights relay | |



WARNING: WEAR EYE PROTECTION WHEN CHARGING OR BOOSTING BATTERY.

Cab fuse box

The electrical system is protected by fuses which are grouped in a plastic fusebox positioned to the right of the dashboard.

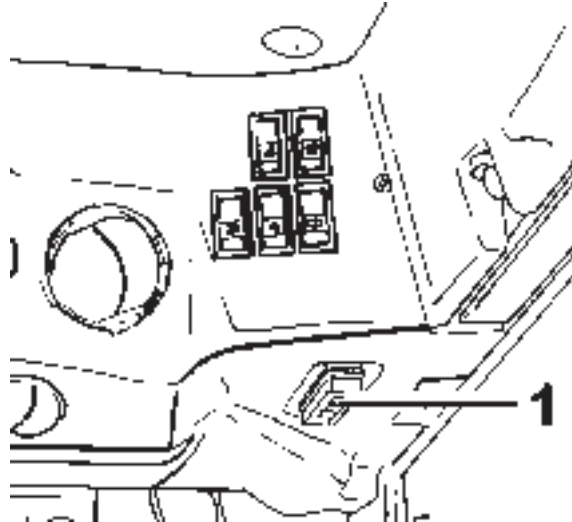

1 - Cab fuse box and relays

Should any component of the electrical system fail to function, check the corresponding fuse and replace it as necessary. In the event of a sudden breakdown, temporarily replace a fuse covering an important function (e.g. a headlight) by another of less importance. Always switch off the ignition and all electrical equipment before changing a fuse or a relay.



DANGER: MAKE SURE YOU CONNECT THE BATTERY TERMINALS CORRECTLY. DANGER OF SHORT-CIRCUIT!

Cab fuse box

- F1 - Flasher unit
- F2 - Radio
- F3 - Air conditioning
- F4 - Blower/heater
- F5 - Front wiper
- F6 - Rear wiper
- F7 - Front work lights
- F8 - Rear work lights

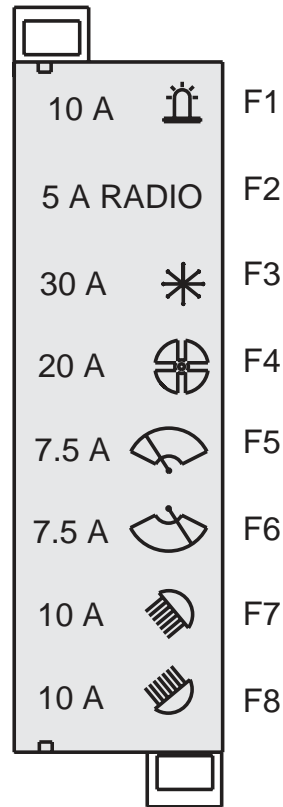

Before changing a blown fuse, switch off the electrical power at the ignition switch, eliminate the problem which caused the fuse to blow, and then replace the fuse with a new one of the same rating.



DANGER: START THE ENGINE, WITH THE STARTER KEY, FROM THE OPERATOR'S SEAT ONLY. DO NOT ATTEMPT TO START THE ENGINE BY SHORTING ACROSS THE STARTER TERMINALS. THE MACHINE WILL START IN GEAR IF THE NEUTRAL START CIRCUIT IS BYPASSED. THIS COULD CAUSE SERIOUS INJURY OR DEATH TO ANYONE IN THE VICINITY OF THE TRACTOR. ENSURE THAT THE ENGINE STARTER SOLENOID COVER IS ALWAYS IN POSITON.

Electrical system

Electrical system components

| | |
|-------|------------------------------------------------|
| 2 | Clutch safety start |
| 3 | Stop sensor |
| 4 - 5 | Stop lights |
| 6 | Preheating glow plug |
| 7 | Preheating glow plug lamp |
| 8 | Preheating solenoid valve |
| 9 | Preheating switch |
| 10 | Teste temperature sensor |
| 11 | Engine oil temperature sensor |
| 12 | Hazard warning triangle |
| 17 | Fuel low warning lamp |
| 18 | Fuel gauge |
| 19 | Fuel gauge sensor |
| 20 | Oil temperature gauge |
| 21 | Oil/liquid temperature sensor |
| 22 | Rear PTO selection lamp (540 rpm) |
| 23 | PTO engage sensor 540 rpm |
| 24 | Rear PTO selection lamp (1000 rpm) |
| 25 | PTO engage sensor 1000 rpm |
| 30 | 4WD lamp |
| 32 | Trailer brake lamp |
| 33 | Trailer brake sensor |
| 34 | Tractor meter |
| 35 | Alternator lamp |
| 36 | Hydraulic oil filter clog lamp |
| 37 | Hydraulic oil filter clog sensor |
| 40 | Air filter clog lamp |
| 41 | Air filter clog sensor |
| 42 | Brake fluid level lamp |
| 43 | Brake fluid level sensor |
| 44 | Rear PTO to move lamp |
| 45 | Service sensor (solenoid valve block pressure) |
| 46 | Ground speed pto lamp |
| 47 | Ground speed pto sensor |
| 48 | Low engine oil pressure lamp |
| 49 | Low engine oil pressure sensor |
| 50 | Diff-lock lamp |
| 51 | Diff-lock switch |
| 52 | Diff-lock solenoid valve |
| 53 | 4WD switch |
| 54 | 4WD solenoid valve |

| | |
|-----|------------------------------------------|
| 59 | Rear pto solenoid valve |
| 60 | Rear PTO start switch |
| 61 | Economy PTO selection lamp |
| 62 | Economy PTO sensor |
| 63 | Handbrake sensor |
| 66 | Parking lights lamp |
| 67 | Front left parking light |
| 68 | Rear right parking light |
| 69 | Front right parking light |
| 70 | Rear left parking light |
| 71 | Registration plate light |
| 72 | Right dipped beam |
| 73 | Left dipped beam |
| 74 | Left high beam |
| 75 | Right high beam |
| 76 | High beam indicator lamp |
| 77 | Horn |
| 83 | Direction indicator lamp |
| 84 | First trailer direction indicator lamp |
| 85 | Second trailer direction indicator lamp |
| 86 | Front Left Direction Indicator |
| 87 | Rear left direction indicator |
| 88 | Front right direction indicator |
| 89 | Rear right direction indicator |
| 93 | Rear work lights |
| 94 | Rotating beacon socket |
| 95 | Seat socket |
| 96 | Flashing light socket |
| 101 | Preheating pushbutton |
| | |
| A | Ignition switch |
| B | Starter motor |
| C | Electronic regulator control unit |
| D | Front control valves variant |
| E | 65A alternator with w socket |
| F | Lights, indicators and horn command |
| G | Direction indicator command control unit |
| H | Hazard warning command |
| I | Trailer socket |
| M | H M L control unit |
| N | Preheating control unit |
| P | Tank II fuel pump. |
| T | Cigar lighter |
| | |
| R1 | Preheating relay |
| R2 | Start enable relay |
| R3 | Keystart switch circuits relay |
| RP | Temperature relay |

Electronic system diagram (Electronic governor)

- part one

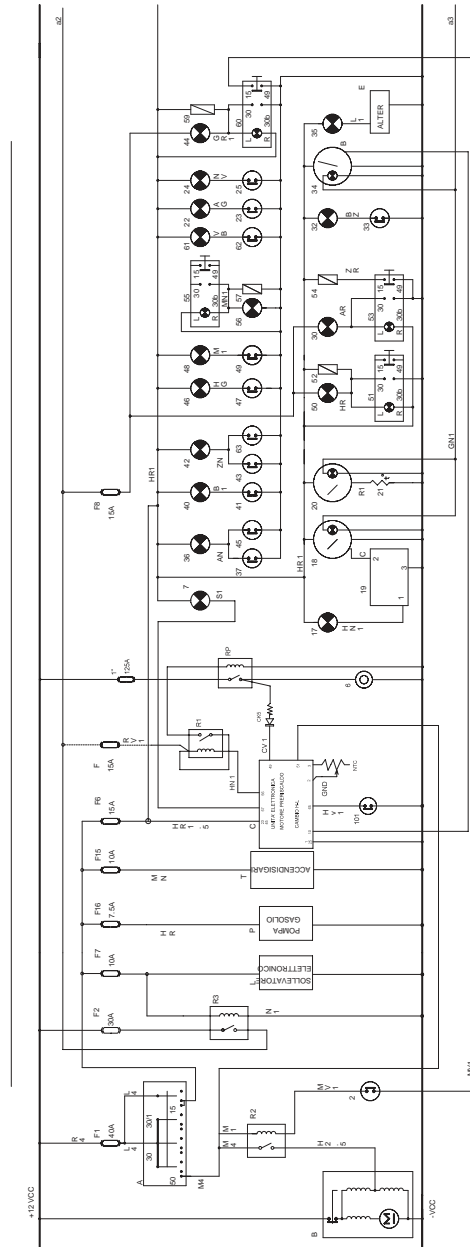

- part two

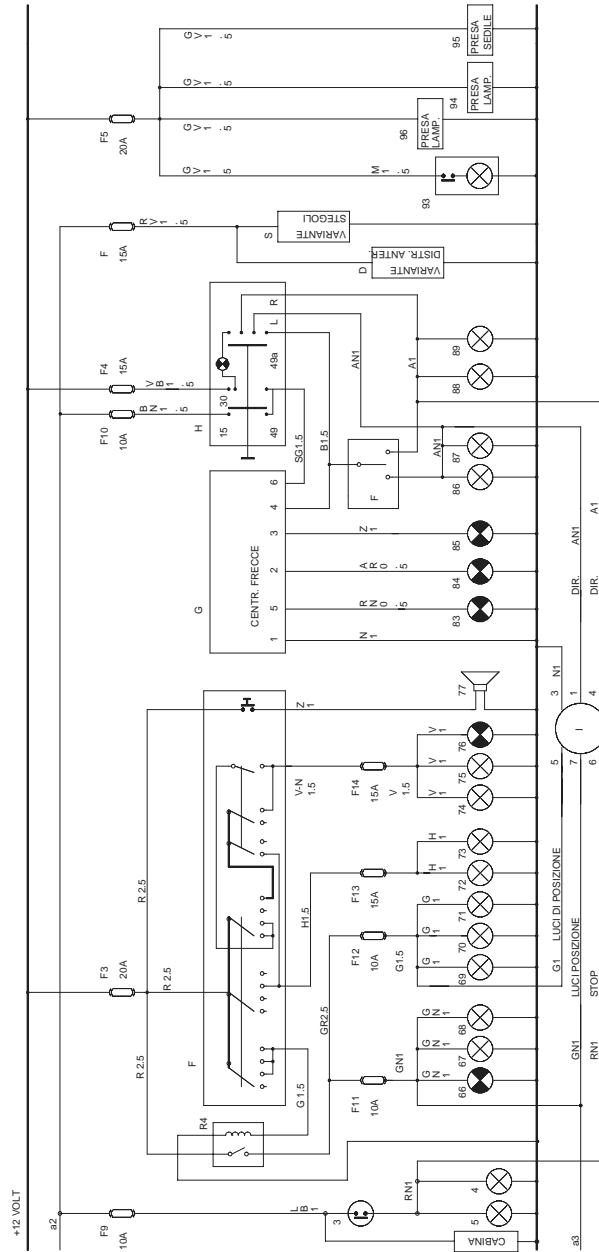

Electronic system diagram (Mechanical governor)

- part one

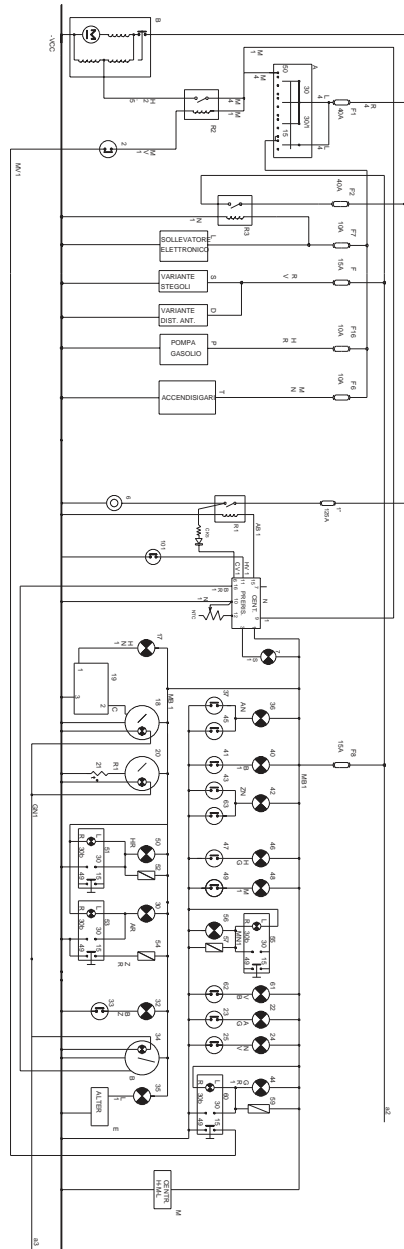

- part two

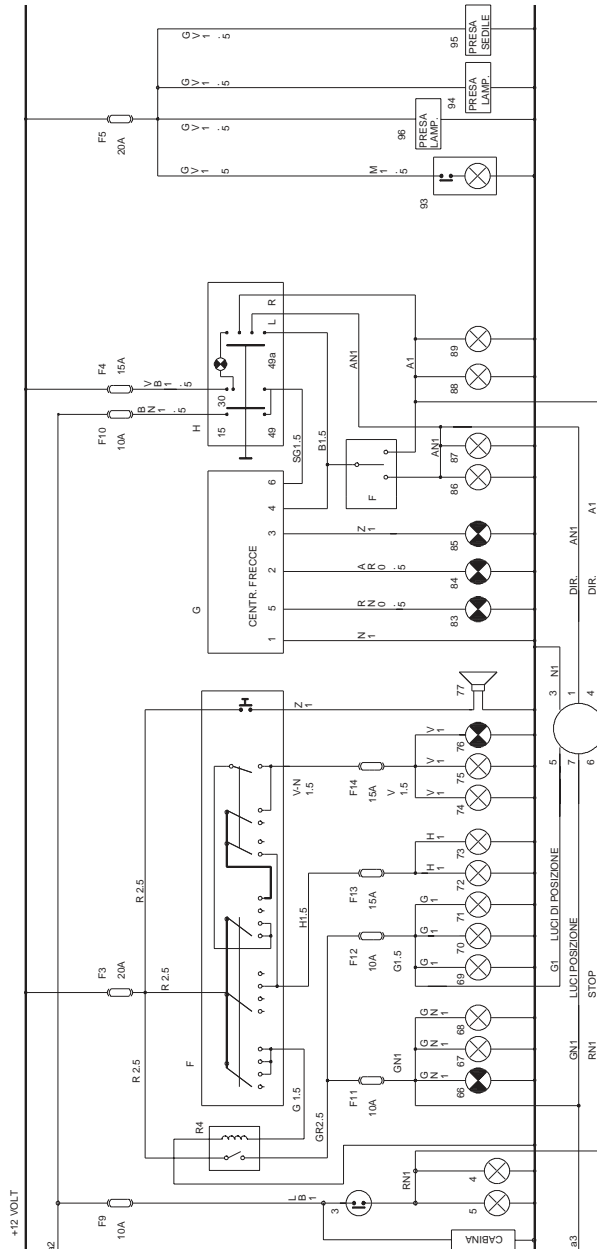

Air conditioning system schematic

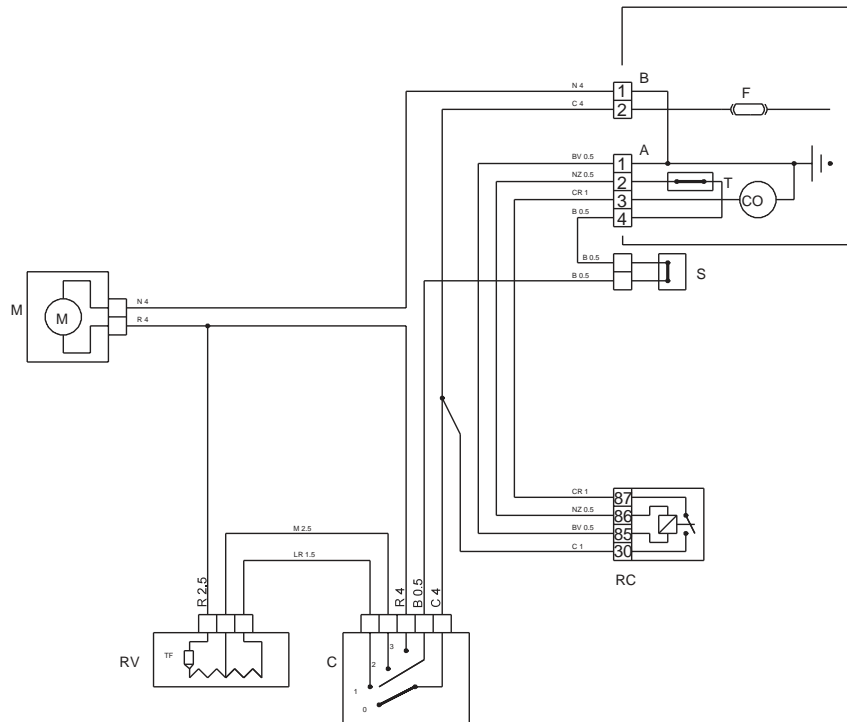

Key to air conditioning components

- M**
RV Blower speed control resistor
C Blower speed selector
RC Air conditioner relay
F Power supply fuse
T Air conditioning pressure switch
CO Compressor
S Thermostat
B Supply block
A Block for air conditioning system variant

Colours of wires connected to fuse holder box

- | | | |
|------------|----------------|------------|
| M - brown | V - green | Z - purple |
| N - black | S - pink | R - red |
| C - orange | A - light blue | B - white |
| L - blue | G - yellow | H - grey |

Cab electrical system schematic

- 1 - Flashing light switch
 - 2 - Flashing light
 - 3 - Courtesy light
 - 4 - 12V outlet socket for radio
 - 5 - Air conditioning system relay
 - 6 - Condenser fan
 - 7 - BORLETTI air conditioning - heating system
 - 8 - Pressure switch
 - 9 - Freon compressor
 - 10 - Heating alternator
 - 11 - Windscreen wiper switch
 - 12 - Windscreen wiper motor
 - 13 - Front screenwash pump
 - 14 - Screenwash pushbutton
 - 15 - Console lighting
 - 16 - Rear screen wiper motor
 - 17 - Rear screenwash pump
 - 18 - Front worklights switch
 - 19 - Front worklights
 - 20 - Rear worklights switch
 - 21 - Rear worklights
 - 22 - Wipers control unit
 - 23 - Screenwash pushbutton
- A - Air conditioning variant block
 B - Feed block
 R - Electrical heating variant block

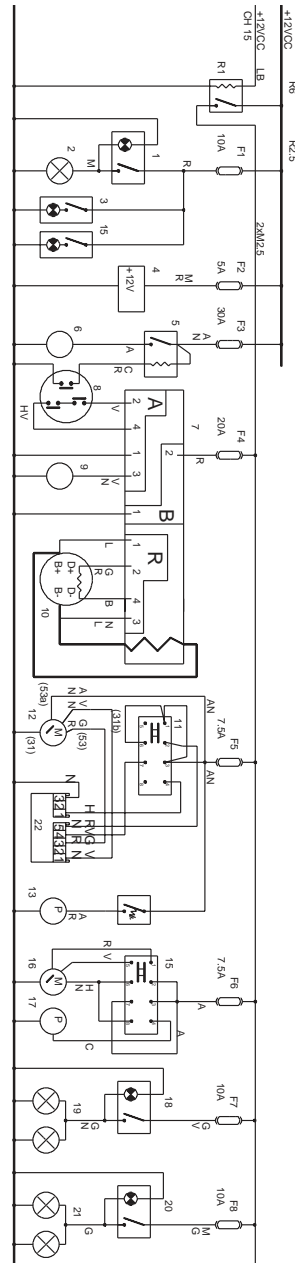

Electronic lift control unit

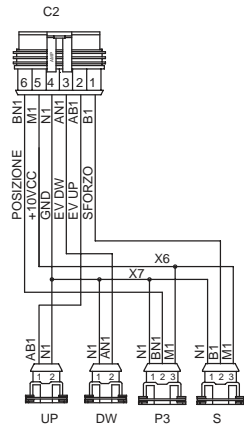
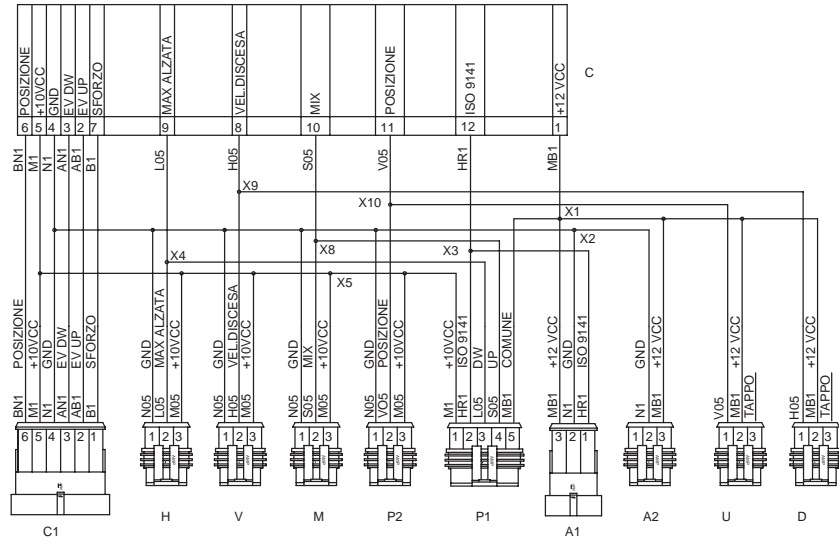

- UP - SV up
- DW - SV down
- P3 - Position
- S - Draft
- H - Maximum lift height
- V - Rate of drop
- M - Mix control
- P2 - Position control
- P1 - Up-down switch
- A1 - + 12 Volt
- C - Electronic lift control unit
- A2 - Lift (cab)
- U - Up
- D - Down

Lights

Cleaning the headlights and sidelights

Clean with water or specific commercial products. We recommend that you switch off the lights before cleaning.

Bulb replacement

Front headlights H4 12V 60/55W *double filament bulb*

The headlights have double- filament bulbs for main and dipped beam illumination.

To replace the bulbs, remove the front grille and proceed as follows:

- detach connector **1** from the base of the bulb.
- peel back and remove the rubber cover **2**.
- turn slightly the spring clip **3** that holds the bulb base **4** in position and detach it from the reflector.



WARNING: *avoid touching the inner surface of the reflector. Make sure no foreign material gets inside the reflector.*

- Insert the new bulb so that the locator tabs engage the notches in the rim of the reflector **5**.
- Replace the rubber cover **2**, making sure that it fits snugly against the edge of the reflector.
- Push connector **1** onto the terminals on the bulb base.

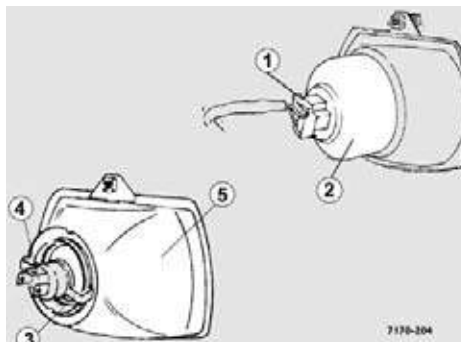

Rear light assemblies

The tractor is equipped with two rear light assemblies on each fender (right and left) comprising the following lights:

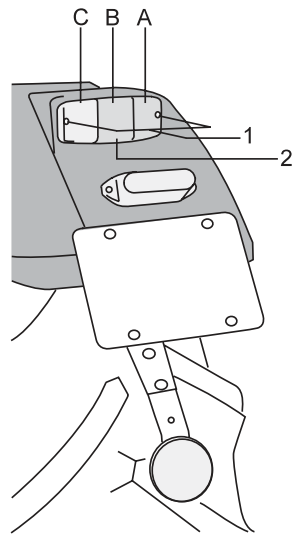

A - red tail light.
Bulb: DIN 72601-R5W 12V 5W

B - brake light.
Bulb: DIN 72601-P21 12V 21W

C - direction indicator light.
Bulb: DIN 72601-P21 12V 21W

To replace any of these bulbs, proceed as follows:

- Remove the screws **1** securing the red or yellow-red lens **2**.
- Gently remove the lens **2** to access the bulb.
- Turn the defective bulb counter-clockwise under slight pressure as far as it will go.
- Remove the bulb.
- Insert the new bulb and turn clockwise under slight pressure as far as it will go.
- Replace the lens **2** and secure with the screws **1**.

Front sidelights and direction indicators

- For tractors with cab

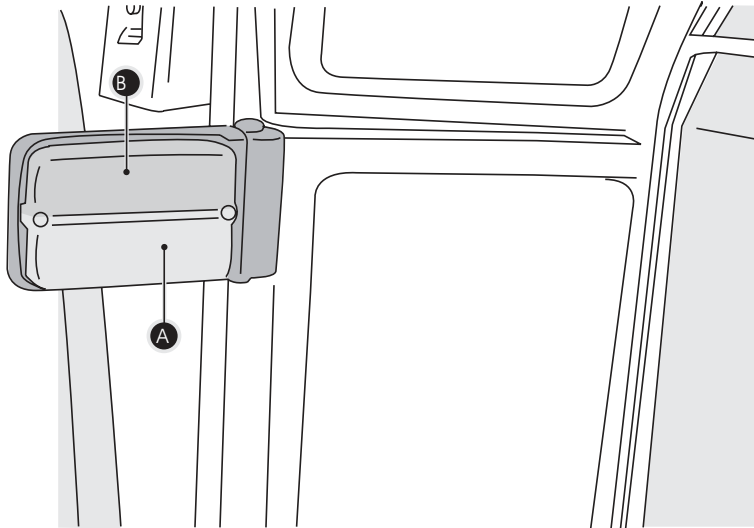

The light clusters mounted on each side of the tractor contain two bulbs:
A - sidelights B - direction indicators.

Bulb: DIN 72601-R5W 12V 5W - sidelight

Bulb: DIN 72601-P21 12V 21W - direction indicator

To replace either of the bulbs, proceed as follows:

- Remove the two screws securing the yellow-white lens.
- Gently remove the lens to access the bulb.
- Apply light pressure and turn the defective bulb counter-clockwise as far as it will go.
- Remove the bulb.
- Insert the new bulb, apply light pressure and turn it clockwise as far as it will go.
- Replace the lens and the two retaining screws.

IMPORTANT



On cabled tractors the side-lights on the front fenders are mounted on a movable support . This support must be positioned as indicated in the figure when driving on the public highway.



When necessary, the side-lights supports can be turned inwards to prevent them getting caught on overhanging branches. (as shown in the figure).

Remember to return the sidelights to their working position before driving on the public highway.

Front and rear working lights in cab roof

To replace the bulbs, proceed as follows:

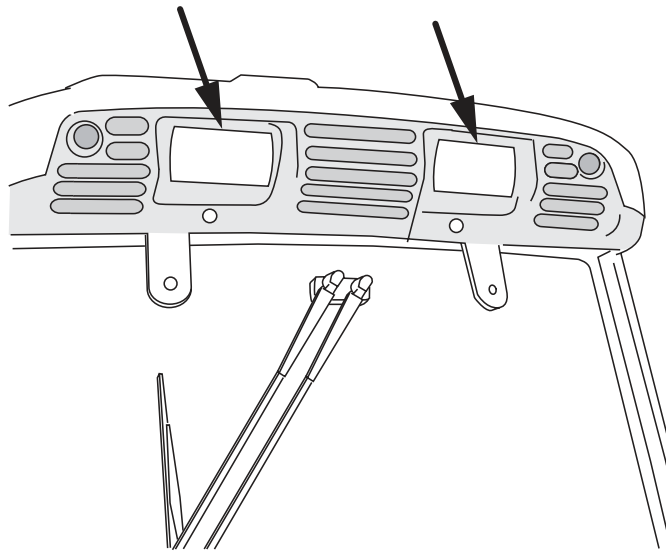

- Carefully clean the outside of the light unit to avoid the risk of dirt getting on the reflector during bulb replacement.
- Using your hands only (tools could easily damage the components) unscrew the two screws securing the rear cover and access the bulb as follows:
- Detach the connector from the bulb base.
- Slightly rotate the spring clip that holds the bulb base in position, and detach it from the reflector, disconnecting also the lead connected directly to the bulb.

WARNING: avoid touching the inner surface of the reflector. Make sure no foreign material gets inside the reflector.

- Insert the new bulb, engaging the locating tabs with the notches on the reflector rim. Connect the bulb lead.
- Push connector 1 onto the terminals on the bulb base.

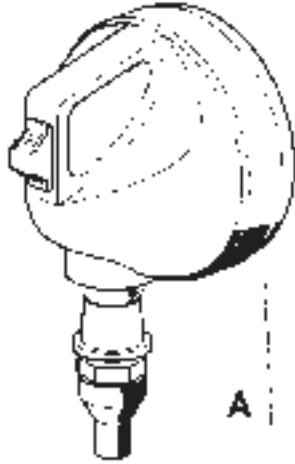
Rear work lights for tractors with platform

To replace the bulb, proceed as follows:

- Remove the rubber gasket and then the glass cover.
 - Push down lightly on the bulb while turning it counter-clockwise as far as it will go.
 - Pull out the bulb.
 - Push the new bulb fully into the holder, and, applying light downward pressure, turn the bulb clockwise as far as it will go.
 - Refit the glass cover and the rubber gasket.
- Rear work lights for tractors with platform.

WARNING: only fit replacement bulbs of the same type and specification as those originally fitted.

**DANGER: WHEN HANDLING BATTERIES:**

- AVOID BREATHING IN FUMES PRODUCED BY THE ACID SOLUTION (if the acid is accidentally swallowed, drink plenty of water or milk, then drink beaten eggs or vegetal oil; seek medical attention immediately)
- USE THE APPROPRIATE PROCEDURE WHEN CHARGING
- CLEAN ALL PARTS WHERE ACID SOLUTION MIGHT HAVE SPILLED. IF IT SPILLS ON THE HANDS, NEUTRALIZE IT WITH HYDRATED LIME OR SODIUM BICARBONATE. IF IT HITS THE EYES, RINSE REPEATEDLY FOR 10-15 MINUTES, THEN SEEK MEDICAL ATTENTION IMMEDIATELY.

Headlight alignment

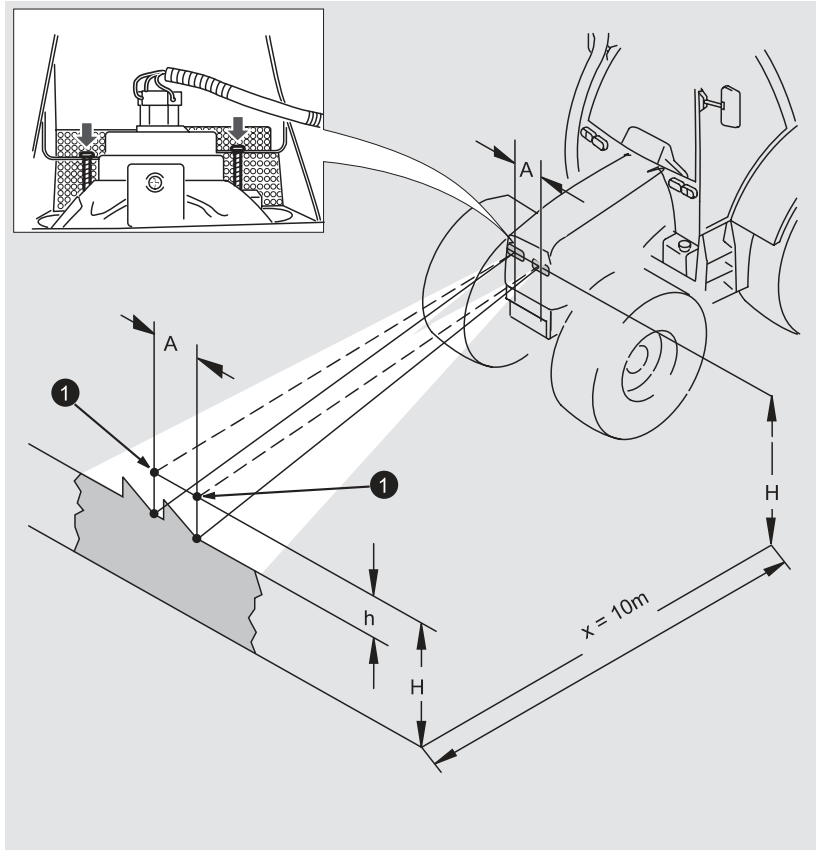

The tractor must be in normal road-going conditions and parked on a level surface at a distance of 10 m (32,8 Ft) from a wall (tyres must be inflated to the correct pressures and the front wheels must be positioned for travel in a straight line).

Switch on the dipped beam headlights.

1 - points on the wall corresponding to the centres of the headlights

A - distance apart of headlights

H - height of headlights

h - distance of the centre of the beam from the horizontal axis

X - distance between headlights and wall

Turn the adjuster screws indicated by the arrows in the figure to move the beam in a vertical or horizontal direction.

NOTE: in order to determine the points on the wall corresponding to the centres of the headlights, we recommend that you bring the tractor up to the wall with the dipped headlights on, mark the centres on the wall and then move back to a distance of **10 m (32,8 Ft)** from the wall.

Horizontal adjustment

With the headlights switched on, the centres of the beams should be apart the distance **A** indicated in the figure.

Vertical adjustment

With the headlights on, the lines delimiting the light and dark zones on the wall should **10cm (3,94 in)** apart as shown in the figure.

IMPORTANT: The figure refers to headlight alignment for driving on the right-hand side of the road. For driving on the left-hand side of the road, the dark beam zone projected on the wall must be symmetrical to that shown in the figure (i.e. the points of the dark zone that penetrate the light zone must always be directed towards the edge of the road).).



CAUTION: ALWAYS WEAR CLOTHING SUITABLE FOR THE TYPE OF WORK TO BE PERFORMED. IF NECESSARY, USE HEARING PROTECTION PLUGS AND WEAR EYE PROTECTION.