

**AIRMAN®**

# Zero Tail Swing Type Mini EXCAVATOR



AX30u-4

ΔX30u-4

ΔX35u-4

ΔX40u-4

ΔX50u-4



AX40u-4

**HOKUETSU INDUSTRIES CO., LTD.**  
<https://tractormanualz.com/>

# Easy Maintenance

New AX-u-4 series with tilting cabins and opening covers make scheduled servicing very easy.

## Job-Proven Original Bushings

The job-proven original bushing is utilized at each front pin joint to cut jearking and service down.

**Lubrication interval:**  
each 500 hours



## Split-Type Front Hoses



the split-type front hoses makes easy replacement at the machine cover ports and the back of the booms.

## Single Swing Pin

The large single swing pin is provided to eliminate jerking at swing post.



**Durable Flat-Bottom Bucket** to minimize bucket bottom wear

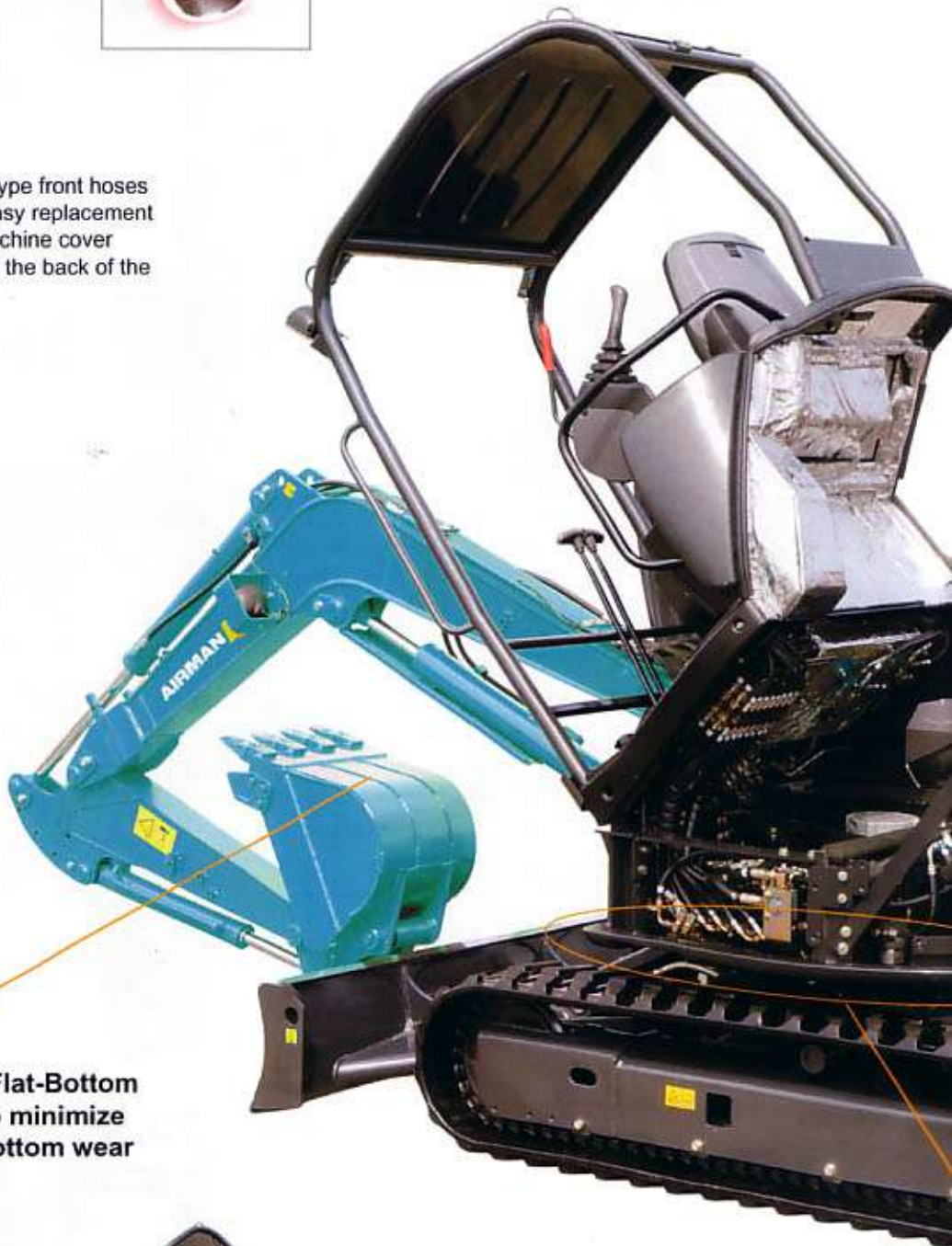

## Tilt-up Floor

The cabin or canopy floor can be tilted up to 50 degree for easy and quick service. It makes easy access for the swing motor, the engine starter motor, the control valve and so on. It dramatically saves inspection and maintenance time.



## Layout of components

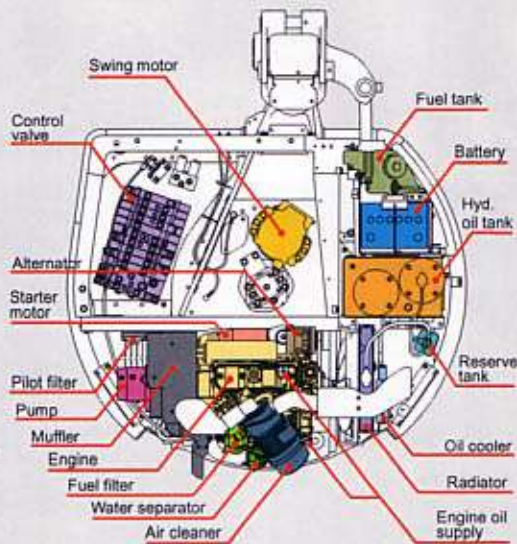

The above layout is for AX30u/35u.

## Track Frames Promote Easy Mud Removal

The X-beam track frame is rounded for smooth mud removal to minimize mud packing trouble and saves cleaning time and disposal costs.

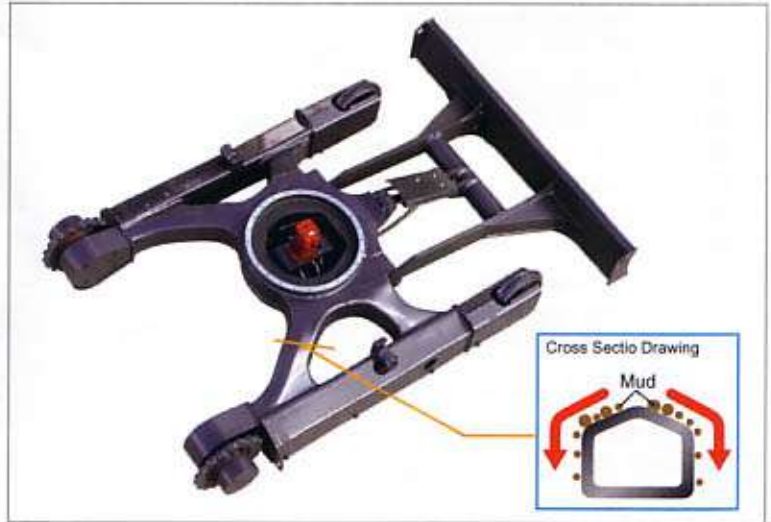

The radiator and the oil cooler is made of aluminum for longer life.

## New Structure Rubber Crawlers

The new structure rubber crawlers improve durability.

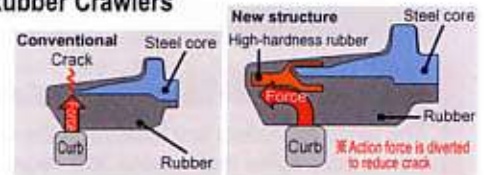

Steel cover for easy access to engine.

## Slide Type Engine Cover

The engine cover can slide up and down for quick service even in confined space. The right side swing cover opens for quick battery check.



## Reinforced D-Shaped Frame

The reinforced D-shape frame at the bottom of the swing structure protects the body from damage and shock by obstructions.

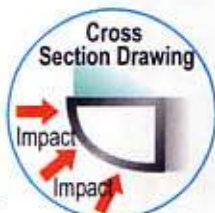

WC (welding tungsten carbide) to minimize wear at the face of the arm edge

# Operator Comfort and Safety

There is a large comfortable cabin for operators comfort.

## Equipment

### Standard

- Auto-idling
- Reclining seat
- Seat belt
- Drink holder
- Wrist rest
- 12V outlet
- Folded travel pedal
- Operating mirror (for AX40u/50u)

### Option

- Suspension seat
- Travel alarm

### Cabin Equipment

- Air conditioning
- AM/FM radio
- Window washer
- Defroster
- Ashtray
- Operating mirror

### Cabin Option

- Head guard



Cabin spec.

Folded travel pedal



## Air conditioning (Cabin version)

The large air outlets are located at the operators feet with a front outlet that rotates 360 degrees and services as a window defloster.

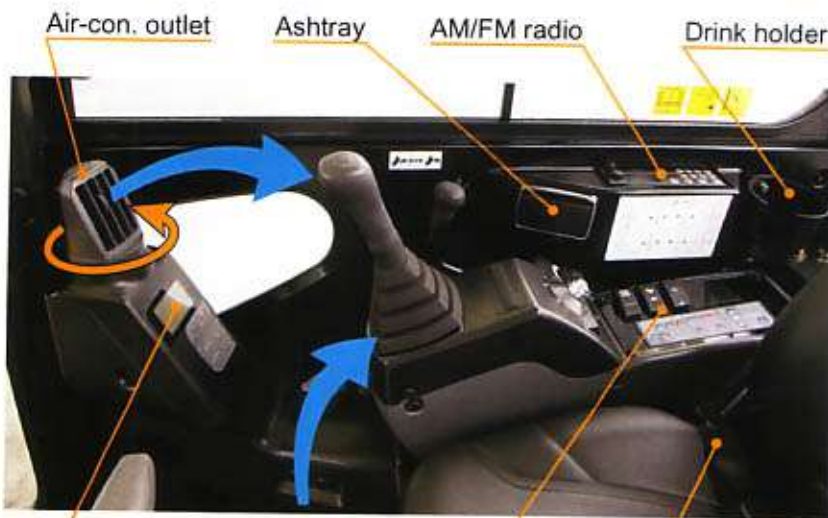

## Shock-Absorbing Rubber Mounted Floor



There are 4 shock-absorbing rubbers to ensure comfortable operation.

## Folded Large Cabin Door

Two steps folded door makes easy access for an operator.

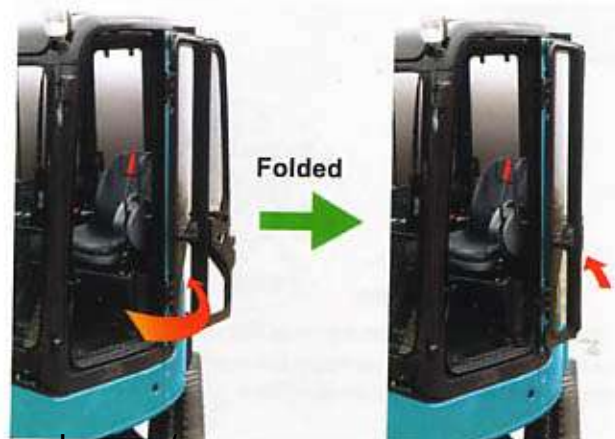

## Easy-to Read Monitor

The large LCD monitor clearly shows fuel level, coolant temp. and the status of various other indicators for the operator at the front right position.

# ROPS/FOPS Canopy and Cabin

Both canopy and cabin are compliant to the latest ROPS, TOPS and FOPS as standard.



## Improved Visibility with Roof Sun Visor (Canopy)



The sun visor is equipped to give better visibility when raining or wet.

## Pilot Control Shut-Off Lever Neutral Engine Start System

When the pilot control lever is up, all operations such as front, swing, travel and blade are shut off. It prevents accidental movement.

Only when the pilot control shutoff lever is locked, the engine can start. It eliminates unexpected operation if the engine is suddenly started accidentally.



## Storage Space



Tool box for canopy spec.



## Both the swing and travel parking brakes are provided to improve safety.

## Auto-Idle Device

The engine speed is automatically lowered to idling speed to save fuel consumption when the control lever is at neutral for 4 seconds.



## Smooth and Speedy Compound Performance

The matching between the 3 hydraulic pumps system and the arm recovery circuit is improved for AX30u/35u. On the other hand, the matching between the original hydraulic circuit (AHCS) and the arm recovery circuit is also improved for AX40U/50U. New AX-u-4 series increase working efficiency.

## Hydraulic Pilot Control

The operation levers are controlled by all hydraulic pilot type. It reduces load of the lever operation.

## Enlarged Counterweight and Weighted Undercarriage

The newly developed box-section frame makes low weight and high durability. The enlarged counterweight and weighted undercarriage gives lower center of gravity and improves stability.

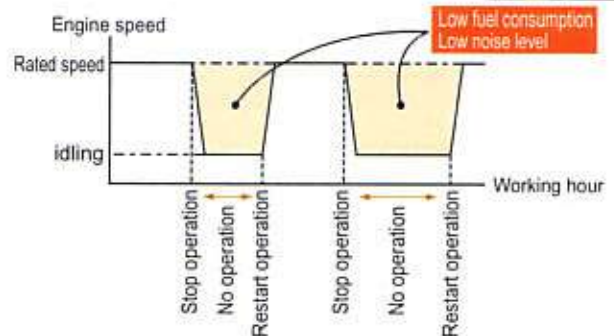

## Automatic Travel Speed Control at High Speed

The travel speed is automatically switched to low speed when the load increases for steering during high speed travel. It is automatically resumed when the load decreases.

## Hydraulic oil interval : 2,000 hrs

# SPECIFICATIONS

## AX30u-4/35u-4

### ENGINE

Model	Yanmar 3TNV88
Type	Water-cooled, 4-cylce, 3-cylinder, direct injection type diesel engine
Rated power	
SAE J1349	22.3 kW (29.9HP) at 2,500 min <sup>-1</sup> (rpm)
DIN 6271	22.1 kW (30.0HP) at 2,500 min <sup>-1</sup> (rpm)
JIS D1005	22.3 kW (30.3HP) at 2,500 min <sup>-1</sup> (rpm)
Maximum Torque	105 N.m (11 kgf.m) at 1,500 min <sup>-1</sup> (rpm)
Bore & Stroke	88 x 90 mm
Piston displacement	1.642 L
Battery	1 x 12 V, 55 Ah

### HYDRAULIC SYSTEM

The proven 3-pump system and arm regenerative circuit have been improved to make combined operations and fine control easier and smoother.

Main pumps	Two variable displacement axial piston pumps
Maximum oil flow	2 x 40 L/min
Third pump	One gear pump
Maximum oil flow	26.3 L/min
Pilot pump	One gear pump
Maximum oil flow	11.3 L/min

### RELIEF VALVE SETTINGS

Main pumps circuit	24.5 MPa
Third pump circuit	20.6 MPa
Pilot circuit	3.9 MPa

### HYDRAULIC CYLINDERS

High-strength piston rods and tubes. Cylinder cushion mechanisms provided in boom raise, arm roll-in and roll-out circuits to absorb shocks at stroke ends.

### DIMENSIONS

	Quantity	Bore	Rod Diameter	Stroke
Boom Canopy	1	80 mm	45 mm	579 mm
	1	85 mm	50 mm	576 mm
Boom Cabin	1	80 mm	45 mm	563 mm
	1	85 mm	50 mm	564 mm
Arm	1	70 mm	40 mm	546 mm
	1	75 mm	45 mm	597 mm
Bucket	1	65 mm	40 mm	435 mm
	1	65 mm	40 mm	435 mm
Boom swing	1	85 mm	45 mm	525 mm
	1	85 mm	45 mm	525 mm
Blade	1	85 mm	45 mm	135 mm
	1	95 mm	45 mm	140 mm

Figure in  are data on the AX30u-4  
Figure in  are data on the AX35u-4

### CONTROLS

Hydraulic pilot control levers for all operations.

### FRONT ATTACHMENTS

#### BACKHOE BUCKETS

ISO 7451 capacity	Width		No. of teeth	Weight	Front Attachment			
	Without side cutters	With side cutters			AX30u-4		AX35u-4	
					1.17m arm	1.52m arm	1.32m arm	1.72m arm
0.055 m <sup>3</sup>	300 mm	350 mm	3	60 kg	A	A	A	A
0.065 m <sup>3</sup>	350 mm	400 mm	3	65 kg	A	A	A	A
0.08 m <sup>3</sup>	400 mm	450 mm	3	67 kg	A	A	A	A
0.09 m <sup>3</sup>	450 mm	500 mm	4	73 kg	A	A	A	A
0.10 m <sup>3</sup>	500 mm	550 mm	4	76 kg	A	B	A	A
0.11 m <sup>3</sup>	550 mm	600 mm	4	80 kg	B	C	A	B
0.13 m <sup>3</sup>	600 mm	650 mm	4	84 kg	C	C	B	C
0.14 m <sup>3</sup>	650 mm	700 mm	4	87 kg	-	-	C	-
0.15 m <sup>3</sup>	700 mm	750 mm	4	89 kg	-	-	C	-
Arm crowd force					17.2 kN	14.7 kN	19.1 kN	17.2 kN
Bucket digging force					27.5 kN	27.5 kN	27.5 kN	27.5 kN

A: General digging B: Light-duty digging C: Loading

### SWING MECHANISM

High-torque, axial piston motor with planetary reduction gear. Swing circle is single-row, shear-type ball bearing with induction-hard-ended internal gear. Internal gear and pinion are immersed in lubricant. Swing parking brake is spring-set/hydraulic-released disc type. Swing shockless valve built in swing motor absorbs shocks when stopping swing, ensuring smooth stops.

Swing speed ..... 9.3 min<sup>-1</sup> (9.3 rpm)

### UNDERCARRIAGE

#### TRACKS

Tractor-type undercarriage. Welded track frame using carefully selected materials. Side frame welded to track frame.

#### NUMBERS OF ROLLERS ON EACH SIDE

Upper roller	1
Lower roller	4

#### TRAVEL DEVICE

Each track driven by a high-torque, 2-speed axial piston motor through planetary reduction gear, allowing counter-rotation of the tracks. Travel shockless relief valve built in travel motor absorbs shocks when stopping travel, ensuring smooth stops.

Travel speeds (rubber shoes)	High: 0 - 4.5 km/hr
	Low: 0 - 2.8 km/hr
Travel speeds (steel shoes)	High: 0 - 4.4 km/hr
	Low: 0 - 2.7 km/hr
Gradeability	30 degrees (58%) continuous

### WEIGHTS AND GROUND PRESSURE

Equipped with AX30u-4: 1.17 m arm and 0.09 m<sup>3</sup> (ISO 7451 capacity) bucket, AX35u-4: 1.32 m arm and 0.11 m<sup>3</sup> (ISO 7451 capacity) bucket.

	AX30u-4		AX35u-4	
	Operating weight	Ground pressure	Operating weight	Ground pressure
<b>Canopy version</b>				
300 mm rubber shoes	3,070 kg	28 kPa	3,480 kg	31 kPa
300 mm steel shoes	3,160 kg	29 kPa	3,570 kg	32 kPa
<b>Cabin version</b>				
300 mm rubber shoes	3,220 kg	29 kPa	3,630 kg	33 kPa
300 mm steel shoes	3,310 kg	30 kPa	3,720 kg	34 kPa

### SERVICE REFILL CAPACITIES

	liters
Fuel tank	40.0
Engine coolant	6.0
Engine oil	7.2
Travel device (each side)	0.6
Hydraulic system	58.0
Hydraulic oil tank (Reference oil level)	35.0

# LIFTING CAPACITIES

## METRIC MEASURE

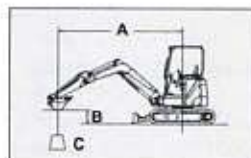

A: Load radius  
B: Load point height  
C: Lifting capacity

### AX30u-4

#### CANOPY VERSION, BLADE ABOVE GROUND



Rating over-side or 360 degrees



Rating over-front

Unit: 1,000 kg

	Load point height	Load radius								At max. reach		
		2 m		3 m		4 m		5 m		meter		
Arm	1.17 m									0.31	0.40	4.21
Rubber shoes	300 mm			0.55	0.70	0.33	0.42			0.26	0.33	4.61
Bucket	0.09 m <sup>3</sup>			0.51	0.65	0.32	0.41			0.24	0.32	4.68
				0.48	0.62	0.31	0.40			0.26	0.34	4.44
		0.91	1.25	0.48	0.62					0.34	0.44	3.79
Arm	1.17 m									0.37	0.47	4.21
Rubber shoes	300 mm			0.63	0.80	0.39	0.49			0.31	0.39	4.61
Bucket	0.09 m <sup>3</sup>			0.59	0.76	0.38	0.48			0.29	0.37	4.68
Extra counterweight	190 kg			0.56	0.73	0.37	0.47			0.32	0.40	4.44
		1.07	1.44	0.56	0.72					0.41	0.52	3.79

#### CANOPY VERSION, BLADE ON GROUND

Unit: 1,000 kg

	Load point height	Load radius								At max. reach		
		2 m		3 m		4 m		5 m		meter		
Arm	1.17 m									0.31	*0.53	4.21
Rubber shoes	300 mm			0.55	*0.83	0.33	*0.76			0.26	*0.52	4.61
Bucket	0.09 m <sup>3</sup>			0.51	*1.19	0.32	*0.86			0.24	*0.56	4.68
				0.48	*1.39	0.31	*0.93			0.26	*0.66	4.44
		0.91	*2.09	0.48	*1.30					0.34	*0.77	3.79
Arm	1.17 m									0.37	*0.53	4.21
Rubber shoes	300 mm			0.63	*0.83	0.39	*0.76			0.31	*0.52	4.61
Bucket	0.09 m <sup>3</sup>			0.59	*1.19	0.38	*0.86			0.29	*0.56	4.68
Extra counterweight	190 kg			0.56	*1.39	0.37	*0.93			0.32	*0.66	4.44
		1.07	*2.09	0.56	*1.30					0.41	*0.77	3.79

### AX35u-4

#### CANOPY VERSION, BLADE ABOVE GROUND



Rating over-side or 360 degrees



Rating over-front

Unit: 1,000 kg

	Load point height	Load radius								At max. reach		
		2 m		3 m		4 m		5 m		meter		
Arm	1.32 m					0.47	0.48			0.37	0.39	4.58
Rubber shoes	300 mm			0.75	0.78	0.46	0.48			0.32	0.33	4.94
Bucket	0.11 m <sup>3</sup>			0.69	0.72	0.44	0.46			0.30	0.31	5.00
				0.66	0.69	0.42	0.44			0.32	0.33	4.78
		1.28	1.37	0.65	0.68	0.42	0.43			0.39	0.41	4.22
						0.55	0.58			0.45	0.46	4.58
Arm	1.32 m					*0.86	*0.86	0.55	0.57	0.39	0.40	4.94
Rubber shoes	300 mm			0.82	0.86	0.53	0.55			0.37	0.38	5.00
Bucket	0.11 m <sup>3</sup>			0.78	0.82	0.51	0.53			0.39	0.41	4.78
Extra counterweight	230 kg			0.77	0.81	0.51	0.53			0.48	0.49	4.22

#### CANOPY VERSION, BLADE ON GROUND

Unit: 1,000 kg

	Load point height	Load radius								At max. reach		
		2 m		3 m		4 m		5 m		meter		
Arm	1.32 m					0.47	*0.71			0.37	*0.52	4.58
Rubber shoes	300 mm			0.75	*0.86	0.46	*0.77			0.32	*0.52	4.94
Bucket	0.11 m <sup>3</sup>			0.69	*1.30	0.44	*0.91			0.30	*0.55	5.00
				0.66	*1.55	0.42	*1.02			0.32	*0.64	4.78
		1.28	*2.24	0.65	*1.50	0.42	*0.99			0.39	*0.81	4.22
						0.55	*0.71			0.45	*0.52	4.58
Arm	1.32 m					*0.86	*0.86	0.55	*0.77	0.39	*0.52	4.94
Rubber shoes	300 mm			0.82	*1.30	0.53	*0.91			0.37	*0.55	5.00
Bucket	0.11 m <sup>3</sup>			0.78	*1.55	0.51	*1.02			0.39	*0.64	4.78
Extra counterweight	230 kg			0.77	*1.50	0.51	*0.99			0.48	*0.81	4.22

Notes: 1. Ratings are based on SAE J1097.

2. Lifting capacity does not exceed 75% of tipping load with the machine on firm, level ground or 87% full hydraulic capacity.

3. The load point is a hook (not standard equipment) located on the back of the bucket.

4. An asterisk mark (\*) indicates load limited by hydraulic capacity.

# SPECIFICATIONS AX40u-4/50u-4

## ENGINE

Model	Yanmar 4TNV88
Type	Water-cooled, 4-cylce, 4-cylinder, direct injection type diesel engine
Rated power	
SAE J1349	29.8 kW (39.9HP) at 2,500 min <sup>-1</sup> (rpm)
DIN 6271	29.5 kW (40.1HP) at 2,500 min <sup>-1</sup> (rpm)
JIS D1005	29.8 kW (40.7HP) at 2,500 min <sup>-1</sup> (rpm)
Maximum Torque	138 N.m (14 kgf.m) at 1,500 min <sup>-1</sup> (rpm)
Bore & Stroke	88 x 90 mm
Piston displacement	2.189 L
Battery	1 x 12 V, 55 Ah

## HYDRAULIC SYSTEM

The AX40U-4 and AX50U-4 are equipped with the High performance Hydraulic System for job efficiency.

Main pumps	One variable displacement axial piston pumps
Maximum oil flow	125 L/min
Pilot pump	One gear pump
Maximum oil flow	12.5 L/min

## RELIEF VALVE SETTINGS

Main pumps circuit	24.5 MPa
Pilot circuit	4.1 MPa

## HYDRAULIC CYLINDERS

High-strength piston rods and tubes. Cylinder cushion mechanisms provided in boom raise, arm roll-in and roll-out circuits to absorb shocks at stroke ends.

## DIMENSIONS

	Quantity	Bore	Rod Diameter	Stroke
Boom Canopy	1	90 mm	55 mm	702 mm
	1	95 mm	55 mm	702 mm
Boom Cabin	1	90 mm	55 mm	691 mm
	1	95 mm	55 mm	691 mm
Arm	1	80 mm	50 mm	698 mm
	1	80 mm	50 mm	731 mm
Bucket	1	70 mm	40 mm	551 mm
	1	70 mm	40 mm	551 mm
Boom swing	1	90 mm	50 mm	664 mm
	1	90 mm	50 mm	664 mm
Blade	1	105 mm	50 mm	140 mm
	1	105 mm	50 mm	140 mm

Figure in  are data on the AX40u-4

Figure in  are data on the AX50u-4

## CONTROLS

Hydraulic pilot control levers for all operations.

## FRONT ATTACHMENTS

### BACKHOE BUCKETS

ISO 7451 capacity	Width		No. of teeth	Weight	Front Attachment			
	Without side cutters	With side cutters			AX40u-4		AX50u-4	
					1.38m arm	1.69m arm	1.38m arm	1.69m arm
0.10 m <sup>3</sup>	400 mm	450 mm	3	92 kg	A	A	A	A
0.11 m <sup>3</sup>	450 mm	500 mm	3	96 kg	A	A	A	A
0.13 m <sup>3</sup>	500 mm	550 mm	4	104 kg	A	A	A	A
0.14 m <sup>3</sup>	550 mm	600 mm	4	109 kg	A	C	A	A
0.16 m <sup>3</sup>	600 mm	650 mm	4	113 kg	C	C	A	B
0.17 m <sup>3</sup>	650 mm	700 mm	4	120 kg	C	C	B	C
Arm crowd force					24.0 kN	21.0 kN	24.0 kN	21.0 kN
Bucket digging force					32.1 kN	32.1 kN	36.8 kN	36.8 kN

A: General digging B: Light-duty digging C: Loading

## SWING MECHANISM

High-torque, axial piston motor with planetary reduction gear. Swing circle is single-row, shear-type ball bearing with induction-hard-ended internal gear. Internal gear and pinion are immersed in lubricant. Swing parking brake is spring-set/hydraulic-released disc type. Swing shockless valve built in swing motor absorbs shocks when stopping swing, ensuring smooth stops.

Swing speed	9.3 min <sup>-1</sup> (9.3 rpm)
-------------	---------------------------------

## UNDERCARRIAGE

### TRACKS

Tractor-type undercarriage. Welded track frame using carefully selected materials. Side frame welded to track frame.

### NUMBERS OF ROLLERS ON EACH SIDE

Upper roller	1
Lower roller	4

### TRAVEL DEVICE

Each track driven by a high-torque, 2-speed axial piston motor through planetary reduction gear, allowing counter-rotation of the tracks. Travel shockless relief valve built in travel motor absorbs shocks when stopping travel, ensuring smooth stops.

Travel speeds (rubber shoes)	High: 0 - 4.5 km/hr
	Low: 0 - 2.8 km/hr
Travel speeds (steel shoes)	High: 0 - 4.2 km/hr
	Low: 0 - 2.6 km/hr
Gradeability	30 degrees (58%) continuous

## WEIGHTS AND GROUND PRESSURE

Equipped with 1.38 m arm and AX40u-4: 0.14 m<sup>3</sup> (ISO 7451 capacity) bucket, AX50u-4: 0.16 m<sup>3</sup> (ISO 7451 capacity) bucket.

	AX40u-4		AX50u-4	
	Operating weight	Ground pressure	Operating weight	Ground pressure
<b>Canopy version</b>				
400 mm rubber shoes	4,390 kg	28 kPa	4,730 kg	30 kPa
400 mm steel shoes	4,460 kg	29 kPa	4,800 kg	30 kPa
<b>Cabin version</b>				
400 mm rubber shoes	4,540 kg	29 kPa	4,880 kg	31 kPa
400 mm steel shoes	4,610 kg	29 kPa	4,950 kg	31 kPa

## SERVICE REFILL CAPACITIES

	liters
Fuel tank	70.0
Engine coolant	6.6
Engine oil	8.6
Travel device (each side)	0.9
Hydraulic system	90.0
Hydraulic oil tank (Reference oil level)	59.0



# LIFTING CAPACITIES

## METRIC MEASURE

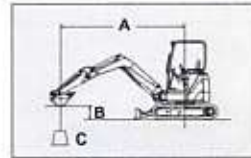

A: Load radius  
B: Load point height  
C: Lifting capacity

### AX40u-4

#### CANOPY VERSION, BLADE ABOVE GROUND



Rating over-side or 360 degrees



Rating over-front

Unit: 1,000 kg

	Load point height	Load radius								At max. reach		
		2 m		3 m		4 m		5 m		meter		
Arm	1.38 m					0.65	0.80			0.40	0.50	5.20
Rubber shoes	400 mm			1.01	1.27	0.62	0.77	0.42	0.52	0.35	0.44	5.49
Bucket	0.14 m <sup>3</sup>			0.91	1.16	0.59	0.73	0.40	0.50	0.34	0.43	5.51
				0.87	1.11	0.56	0.70	0.39	0.49	0.36	0.46	5.26
		1.76	2.40	0.87	1.11	0.55	0.70			0.44	0.56	4.69
						0.74	*0.91			0.47	0.58	5.20
Arm	1.38 m			1.15	*1.36	0.72	0.88	0.48	0.60	0.42	0.52	5.49
Rubber shoes	400 mm			1.04	1.32	0.68	0.84	0.47	0.58	0.40	0.50	5.51
Bucket	0.14 m <sup>3</sup>			1.00	1.27	0.65	0.81	0.46	0.57	0.43	0.53	5.26
Extra counterweight	220 kg			1.00	1.27	0.65	0.81	0.46	0.57	0.43	0.53	5.26
		2.01	*2.48	1.00	1.27	0.64	0.80			0.52	0.64	4.69

#### CANOPY VERSION, BLADE ON GROUND

Unit: 1,000 kg

	Load point height	Load radius								At max. reach		
		2 m		3 m		4 m		5 m		meter		
Arm	1.38 m					0.65	*0.91			0.40	*0.65	5.20
Rubber shoes	400 mm			1.01	*1.36	0.62	*1.06	0.42	*0.95	0.35	*0.66	5.49
Bucket	0.14 m <sup>3</sup>			0.91	*2.02	0.59	*1.28	0.40	*1.01	0.34	*0.72	5.51
				0.87	*2.19	0.56	*1.41	0.39	*1.02	0.36	*0.83	5.26
		1.76	*2.48	0.87	*1.98	0.55	*1.34			0.44	*0.90	4.69
						0.74	*0.91			0.47	*0.65	5.20
Arm	1.38 m			1.15	*1.36	0.72	*1.06	0.48	*0.95	0.42	*0.66	5.49
Rubber shoes	400 mm			1.04	*2.02	0.68	*1.28	0.47	*1.01	0.40	*0.72	5.51
Bucket	0.14 m <sup>3</sup>			1.00	*2.19	0.65	*1.41	0.46	*1.02	0.43	*0.83	5.26
Extra counterweight	220 kg			1.00	*2.19	0.65	*1.41	0.46	*1.02	0.43	*0.83	5.26
		2.01	*2.48	1.00	*1.98	0.64	*1.34			0.52	*0.90	4.69

### AX50u-4

#### CANOPY VERSION, BLADE ABOVE GROUND



Rating over-side or 360 degrees



Rating over-front

Unit: 1,000 kg

	Load point height	Load radius								At max. reach		
		2 m		3 m		4 m		5 m		meter		
Arm	1.38 m					0.80	*0.94			0.47	*0.54	5.42
Rubber shoes	400 mm			1.22	1.47	0.77	0.91	0.52	0.62	0.42	0.50	5.69
Bucket	0.16 m <sup>3</sup>					0.72	0.87	0.51	0.61	0.41	0.49	5.71
				1.07	1.31	0.70	0.84	0.49	0.59	0.43	0.52	5.48
		*2.05	*2.05	1.07	1.31	0.69	0.83			0.51	0.61	4.94
						0.89	*0.94			0.53	*0.54	5.42
Arm	1.38 m			1.36	*1.53	0.86	1.02	0.59	0.70	0.48	*0.54	5.69
Rubber shoes	400 mm					0.82	0.97	0.58	0.68	0.47	0.56	5.71
Bucket	0.16 m <sup>3</sup>					0.79	0.94	0.56	0.67	0.49	0.59	5.48
Extra counterweight	190 kg			1.21	1.47	0.79	0.94	0.56	0.67	0.49	0.59	5.48
		*2.05	*2.05	1.21	1.47	0.78	0.93			0.58	0.69	4.94

#### CANOPY VERSION, BLADE ON GROUND

Unit: 1,000 kg

	Load point height	Load radius								At max. reach		
		2 m		3 m		4 m		5 m		meter		
Arm	1.38 m					0.80	*0.94			0.47	*0.54	5.42
Rubber shoes	400 mm			1.22	*1.53	0.77	*1.15	0.52	*1.01	0.42	*0.54	5.69
Bucket	0.16 m <sup>3</sup>					0.72	*1.42	0.51	*1.10	0.41	*0.58	5.71
				1.07	*2.45	0.70	*1.58	0.49	*1.16	0.43	*0.66	5.48
		*2.05	*2.05	1.07	*2.25	0.69	*1.54			0.51	*0.82	4.94
						0.89	*0.94			0.53	*0.54	5.42
Arm	1.38 m			1.36	*1.53	0.86	*1.15	0.59	*1.01	0.48	*0.54	5.69
Rubber shoes	400 mm					0.82	*1.42	0.58	*1.10	0.47	*0.58	5.71
Bucket	0.16 m <sup>3</sup>					0.79	*1.58	0.56	*1.16	0.49	*0.66	5.48
Extra counterweight	190 kg			1.21	*2.45	0.79	*1.58	0.56	*1.16	0.49	*0.66	5.48
		*2.05	*2.05	1.21	*2.45	0.78	*1.54			0.58	*0.82	4.94

Notes: 1. Ratings are based on ISO 10567.

2. Lifting capacity does not exceed 75% of tipping load with the machine on firm, level ground or 87% full hydraulic capacity.

3. The load point is the center-line of the bucket pivot mounting on the arm.

4. An asterisk mark (\*) indicates load limited by hydraulic capacity.

## ● DIMENSIONS

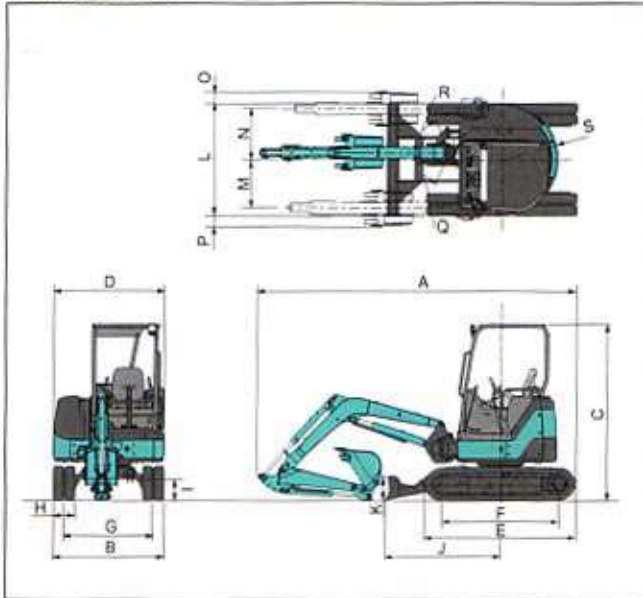

Note:  
The illustration shows the AX30u-4 canopy version equipped with 1.17m arm and 300mm rubber shoes.  
The canopy and cabin conform to ROPS (ISO 3471) and FOPS (ISO 10262, Level 1) requirements.

## ● WORKING RANGES

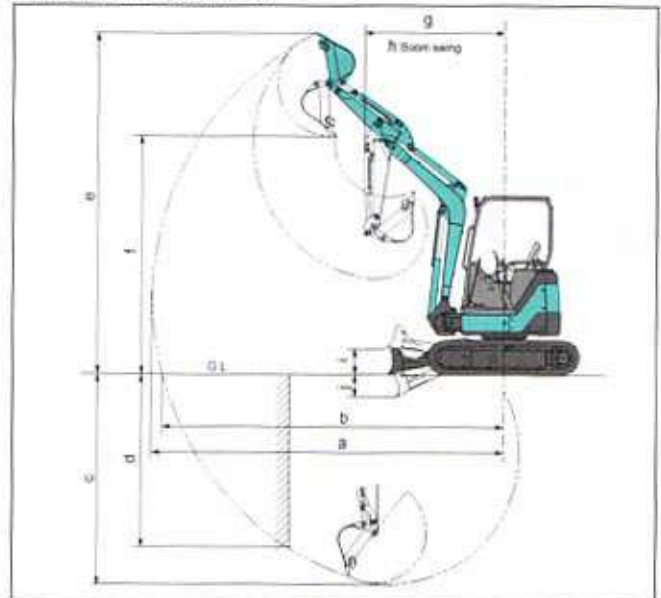

Note:  
The illustration shows the AX30u-4 canopy version equipped with 0.09m<sup>3</sup> bucket, 1.52m arm and 300mm rubber shoes.

## ● DIMENSIONS & WORKING RANGES

Unit: mm

Item		Model		AX30u-4		AX35u-4		AX40u-4		AX50u-4				
Shoe type		Rubber												
Roof type		Canopy		Cabin		Canopy		Cabin		Canopy		Cabin		
DIMENSIONS	A: Max. transport length (with lohg arm)	mm	4,450(4,560)		4,650(4,780)		5,340(5,380)		5,460(5,520)					
	B: Undercarriage width	mm	1,550		1,740		1,960		2,000					
	C: Overall height	mm	2,460	2,500	2,460	2,500	2,510	2,550	2,510	2,550				
	D: Upper structure width	mm	1,550		1,550		1,850		1,850					
	E: Undercarriage length	mm	2,100		2,100		2,540		2,540					
	F: Sprocket center to idler center	mm	1,650		1,650		2,000		2,000					
	G: Distance between undercarriage center	mm	1,250		1,440		1,560		1,600					
	H: Track shoe width	mm	300		300		400		400					
	I: Min. ground clearance	mm	290		290		335		335					
	J: Parallel blade distance	mm	1,610		1,610		1,720		1,720					
	K: Blade height	mm	355		355		360		360					
	L: Blade width	mm	1,550		1,740		1,960		2,000					
	M: Left offset distance	mm	605		605		695		695					
	N: Right offset distance	mm	740		740		860		860					
	O: Right over width	mm	215		170		180		185					
	P: Left over width	mm	80		35		15		20					
Q: Left max. boom swing angle	deg	72	62	72	62	80	80							
R: Right max. boom swing angle	deg	62		62		60		60						
S: Rear edge swing radius	mm	775		870		980		1,000						
WORKING RANGES	a: Max. digging reach (with lohg arm)	mm	4,900(5,170)		5,220(5,530)		5,750(6,050)		6,000(6,250)					
	b: Max. digging reach at ground	mm	4,770		5,100		5,600		5,800					
	c: Max. digging depth (with lohg arm)	mm	2,830(3,130)		3,060(3,460)		3,350(3,660)		3,600(3,860)					
	d: Max. vertical wall (with lohg arm)	mm	2,340(2,460)		2,670(3,020)		2,550(2,910)		2,820(3,160)					
	e: Max. cutting height (with lohg arm)	mm	4,680(4,720)	4,450(4,480)	4,900(5,010)	4,720(4,820)	5,600(5,840)	5,480(5,710)	5,770(6,020)	5,640(5,870)				
	f: Max. dumping height (with lohg arm)	mm	3,260(3,340)	3,040(3,130)	3,490(3,600)	3,330(3,430)	3,920(4,160)	3,810(4,040)	4,100(4,330)	4,000(4,200)				
	g: Min. swing radius (with lohg arm)	mm	1,940(2,060)	2,140(2,170)	2,070(2,170)	2,230(2,290)	2,190(2,340)	2,270(2,390)	2,150(2,260)	2,300(2,340)				
	h: Max. boom swing (with lohg arm)	mm	1,580(1,660)	1,730(1,730)	1,670(1,730)	1,810(2,010)	1,710(1,820)	1,780(1,860)	1,680(1,760)	1,790(1,820)				
	i: Blade bottom highest position (above ground)	mm	360		360		425		425					
	j: Blade bottom lowest position (under ground)	mm	315		390		335		335					

# EQUIPMENT

● **STANDARD EQUIPMENT** Standard equipment may vary by country, so please consult your AIRMAN dealer for details.

## ENGINE

- Water-separator for engine fuel system
- Auto-idling system

## HYDRAULIC SYSTEM

- Hydraulic pilot type control levers
- Pilot control shut-off levers
- Anti-drift valve for front attachments
- Two-speed travel system
- Swing parking brake
- Travel parking brake
- Piping for attachments

## CANOPY (CABIN)

- ROPS/FOPS\*\*
- Seat belt\*\*
- Wrist rest\*\*
- Seat backrest box\*\*
- Air conditioner\*\*\*
- Defroster\*\*\*
- Windshield wiper\*\*\*
- Windshield washer\*\*\*
- Two work lights\*\*
- AM/FM radio\*\*\*
- 12 V outlet\*\*
- Ashtray\*\*\*
- Drink holder\*\*
- Utility box\*
- Rear view mirror\*\*
- Evacuation hammer\*\*\*

### Notes:

- \* For canopy version
- \*\* For canopy and cabin versions
- \*\*\* For cabin version

## UNDERCARRIAGE

- Semi-long stay blade
  - Rubber tracks or Steel tracks
- AX30u-4/35u-4
- 300 mm shoes
- AX40u-4/50u-4
- 400 mm shoes

## FRONT ATTACHMENTS

- O-ring type pin-seals for hoe bucket
  - Original bushing
  - WC spraying
- AX30u-4
- 2.28 m boom
  - 1.17 m arm
  - 0.09 m<sup>3</sup> hoe bucket
- AX35u-4
- 2.47 m boom
  - 1.38 m arm
  - 0.11 m<sup>3</sup> hoe bucket
- AX40u-4
- 2.68 m boom
  - 1.38 m arm
  - 0.14 m<sup>3</sup> hoe bucket
- AX50u-4
- 2.8 m boom
  - 1.38 m arm
  - 0.16 m<sup>3</sup> hoe bucket

● **OPTIONAL EQUIPMENT** Optional equipment may vary by country, so please consult your AIRMAN dealer for details.

## HYDRAULIC SYSTEM

- Swing motion alarm device with lamp
- Travel motion alarm device
- Extra oil flow selector\*\*

## CANOPY (CABIN)

- 2-way control lever pattern selector valve
- Suspension seat\*\*
- Auxiliary light\*\*
- Air clearer inner element

## UNDERCARRIAGE

- Long stay blade
- AX30u-4/35u-4
- 300 mm pad crawler shoes
- AX40u-4/50u-4
- 400 mm pad crawler shoes

### Notes:

- \* For canopy version
- \*\* For canopy and cabin versions
- \*\*\* For cabin version

## FRONT ATTACHMENTS

- Backhoe buckets
- AX30u-4
- 1.52 m arm
- AX35u-4
- 1.72 m arm
- AX40u-4/50u-4
- 1.69 m arm

## COUNTERWEIGHT

- Extra counterweight
- AX30u-4: 190 kg
- AX35u-4: 230 kg
- AX40u-4/50u-4: 220 kg



 **SAFETY**

- Operate safely in accordance with proper operation manual.
- To prevent trouble and accidents, perform daily and preventive maintenance checks without fail.

**AIRMAN**®

**HOKUETSU INDUSTRIES CO., LTD.**

12th Floor Shinjuku San-Ei Bldg.,  
22-2 Nishi-Shinjuku 1-Chome, Shinjuku-ku, Tokyo 160-0023 Japan  
Tel : Tokyo 03(3348)7281 Fax : Tokyo 03(3348)7289  
e-mail : [info@airman.co.jp](mailto:info@airman.co.jp)  
URL : <http://www.airman.co.jp>

**HOKUETSU INDUSTRIES EUROPE B.V.**

Breguetlaan 12, 1438 BC Oude Meer, The Netherlands  
Tel : 31-20-6462636 Fax : 31-20-6462191  
e-mail : [info@hokuetsu.nl](mailto:info@hokuetsu.nl)

**DISTRIBUTOR**