

# AIRMAN®

🇯🇵 JAPANESE QUALITY SINCE 1938

# Mini-Excavator

## Zero Tail Swing Type

## AX-u-7 Series

🇪🇺 EU Stage V-compliant



AX55u



AX55u

AX33u-7  
AX38u-7  
AX48u-7  
AX55u-7

Hokuetsu Industries Europe B.V.  
<https://tractormanualz.com/>

# Efficiency & Comfort

An operating space designed for the ultimate ease of use.  
Energy-saving systems that contribute to reducing fuel costs.  
Improved maintainability in every detail.

By improving operator ease of use as well as providing advanced functions and high performance for digging, loading, leveling, and other work (utility), we have created a new mini excavator that is certain to satisfy customers.



**AX33u-7**    Operating weight **3,330kg**    Capacity **0.08m<sup>3</sup>**  
Rubber shoes, 4-pole canopy



**AX38u-7**    Operating weight **3,960kg**    Capacity **0.10m<sup>3</sup>**  
Rubber shoes, cabin



**AX48u-7**    Operating weight **4,770kg**    Capacity **0.11m<sup>3</sup>**  
Rubber shoes, 4-pole canopy



**AX55u-7**    Operating weight **5,210kg**    Capacity **0.14m<sup>3</sup>**  
Rubber shoes, Cabin



## Large working space

The floor leg space has been expanded. Cab specifications also feature a roomier interior space and larger front windshield, for a larger working space. The opening size of the cab door has also been expanded for easier entry and exit.



## Fuel efficient powerful Stage V-compliant engines provide quick cycle times and an efficient hydraulic system

The engines on the AX33U and AX38U-7 do not require any after-treatment device as the rated output is below 19 kW.

The "common rail system" engines on the AX48U and AX55U-7 are fitted with an EGR and muffler filter to reduce Nox and particulate matter.



## Smooth collecting work

The small gap between the blade and the bucket improves workability for work such as collecting sand and removing asphalt. On the AX48U and AX55U-7 the blade is now extended.



## ECO mode / PWR mode selection

The mode can be easily selected on the multi-monitor.

### • ECO (economy) mode

:Priority is given to fuel economy, for conserving fuel.

### • PWR (power) mode

:Priority is given to work, for when excavating power and higher work speeds are needed.

The engine speed can be adjusted to the required speed using the engine control dial.

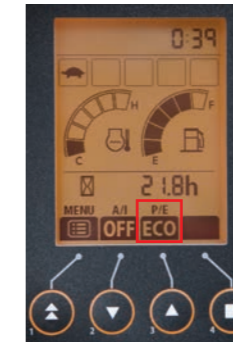

## Hydraulic pilot type control system

The pilot levers have been positioned for ergonomic performance, and the levers are highly rated for their precision operability. The use of a hydraulic pilot system for all controls reduces the required lever operating force.



## Fast & smooth multi-axis operations

- The AX33u/38u delivers even greater work efficiency with an improved combination of our popular 3-pump hydraulic system and arm regeneration circuit.
- The AX48u/55u delivers even greater work efficiency with an improved combination of a hydraulic circuit "AHCS" and arm regeneration circuit.

## Travel speed selector switch

A pushbutton travel speed selector switch is installed on the blade lever. It allows smooth changes in travel speed while operating the blade.



## Automatic idling function

When the operating lever is left in the neutral position for 4 seconds, the engine automatically switches to the idling speed to help reduce fuel consumption and noise.

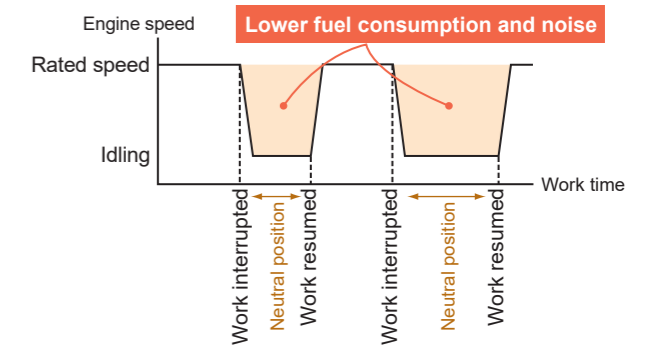

## Automatic idling stop function (optional)

This energy-saving system automatically stops the engine when it has been idling continuously for a long period of time. The time before the engine stops can be selected (3 minutes, 5 minutes, 10 minutes, or 15 minutes).

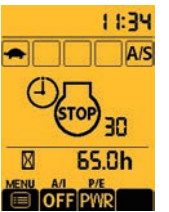

## High visibility multi-monitor

A display that communicates the fuel level, coolant temperature, warning lamps, and other machine status information to the operator is installed at the front right.



## Display items

- Coolant temperature gauge
- Fuel gauge
- Hour meter
- Clock
- Travel mode indicator
- Work light indicator
- Engine indicators
- Overheat indicator
- Engine oil pressure indicator
- Charge indicator
- Fuel level indicator

## Automatic speed change system for high-speed travel

When the machine encounters a slope or other high load during high-speed travel, it automatically shifts to low speed, then restores high speed when the load decreases.

## Comfortable Operation

A large operator space in bright new colors has been created for operator relaxation and comfort.



On this specific picture the AX55U-7 full spec machine is visible, equipped with Airco and auxiliary function levers (proportional) to control the attachments.



On the AX48U and AX55U-7 the EGR & Muffler Filter system Failure Indicators and the manual regeneration switch are situated next to the monitor.

## Good all around visibility



## Vibration-damping floor mounting structure

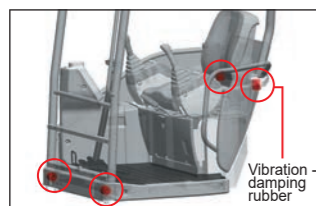

Larger vibration-damping rubber is used in the floor mounts to provide a large improvement in operator comfort.

## Dependable Safety

The design gives top priority to safety, including ROPS/OPG capabilities and operator lever locks.



## ROPS OPG 4-pole canopy and cabin

This structure protects the operator wearing a seat belt in the event that the machine rolls over. The structure conforms to the ROPS (Roll-Over Protective Structure) safety standard. The cab also satisfies the OPG top guard safety standard (standard for operator protective structures) to protect operators from falling objects.

## Secure locks for all operating levers



The use of hydraulic pilot type operating levers allows all levers to be securely locked. A neutral engine start mechanism permits engine start only when the lock lever is locked.

## Foot step for easy entry and exit

A foot step provides a lower entry position. The low step makes it easier to enter and exit the vehicle.



Turning/travel parking brakes are equipped as standard.

# Easy Maintenance

## Easy Maintenance



### Wide opening cover

With a wide radiator side cover that can be easily opened with a latch, as well as our popular sliding-type engine cover that improves maintenance convenience in small spaces, the daily maintenance is easier than ever.

### Battery disconnect switch

The battery disconnect switch allows maintenance to be done in a safe way.



### Split-type floor mat

A split-type floor mat is used, allowing the floor part to be separately removed and cleaned. The pattern shapes have also been improved to make sweeping out the cab easier.

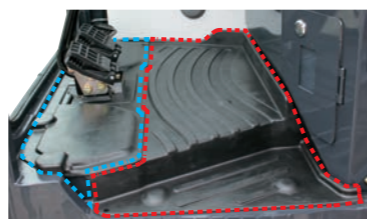

### Mud splash resistant truck frame

The undercarriage resists mud packing and allows any accumulated mud to be easily removed. This allows post-work cleaning to be completed much faster.

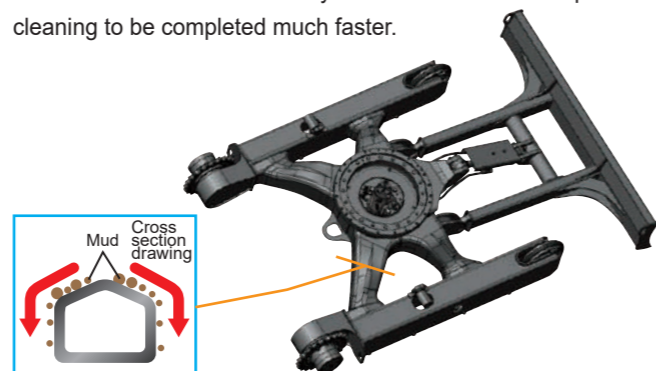

### Parallel radiator and oil cooler layout

The radiator and oil cooler layout has been changed from a series layout to a parallel layout, improving both cleaning convenience and cooling performance.

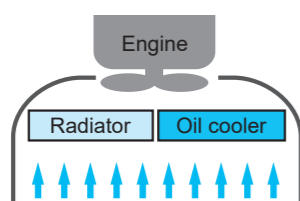

### Anti-clogging radiator and oil cooler

The corrosion-resistant aluminum radiator and oil cooler utilize a wavy fin structure. This structure reduces cooling fan clogging and allows easy cleaning.



### Self-lubricating bushing

Our proven self-lubricating bushing is used in the front pin joint. Grease supply interval: Daily



**Maintenance-free turning speed reducer** (type lubricated by hydraulic oil)

**Grease bath-type turning gear** Grease supply interval: Every 500 hours

**Hydraulic oil change** Oil change interval: Every 2,000 hours

## Tiltable cabin



Tiltable cabine allows easy access to the machines main components.

### Integrated swing post pin

A large integrated pin for the swing post is used, reducing the occurrence of looseness.



### D-shape frame to protect the body from impact

A frame with a D-shape cross section and improved vertical rigidity protects the operator's body in the event of an impact.

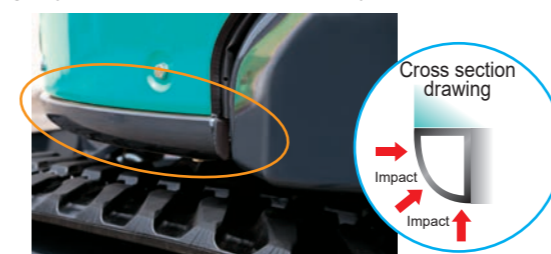

### Durable flat-bottom bucket

Standard equipment with the AXu series includes a flat-bottom bucket that resists wear to the welds of the bucket bottom plate.

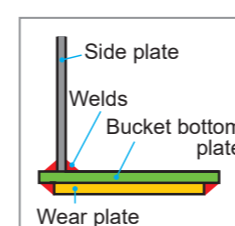

### Reinforced V-shaped boom cylinder guard

The V-shaped guard has been reinforced to prevent damage to the boom cylinder. Two mounting bolts are used to improve strength and prevent looseness.



### Tough blade

A box-section structure is used for the stays to provide greater overall blade reliability. Openings in the stays improve the flow of dirt.

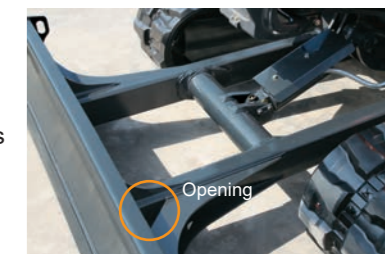

### High durability rubber shoes

Rubber shoes with a steel core shape provide superior durability.

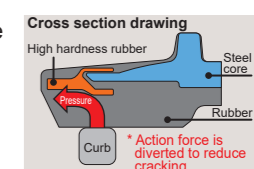

The figure shows the AX33u/38u structure.

## Durability

# SPECIFICATIONS AX33u/38u-7

## ENGINE

Model	Yanmar 3TNV88
Type	4-cycle water-cooled, direct injection
No. of cylinders	3
Rated power	
ISO 14396, net	18.8 kW at 2,400 min <sup>-1</sup> (rpm)
ISO 9249, net	18.8 kW at 2,400 min <sup>-1</sup> (rpm)
SAE J1349, net	18.8 kW at 2,400 min <sup>-1</sup> (rpm)
Maximum torque	91.6 Nm at 1,000 min <sup>-1</sup> (rpm)
Piston displacement	1.642 L
Bore and stroke	80 mm x 90 mm
Battery	1 x 12 V / 55 Ah

## HYDRAULIC SYSTEM

### HYDRAULIC SYSTEM

Main pumps	2 variable displacement axial piston pumps
	1 gear pump
Maximum oil flow	2 x 38.4 L/min
	1 x 22.8 L/min
Pilot pump	1 gear pump
Maximum oil flow	10.8 L/min

### Hydraulic Motors

Travel	2 variable displacement axial piston motors
Swing	1 axial piston motor

### Relief Valve Settings

Implement circuit	24.5 MPa (250 kgf/cm <sup>2</sup> )
Swing circuit	16.7 MPa (170 kgf/cm <sup>2</sup> )
Travel circuit	24.5 MPa (250 kgf/cm <sup>2</sup> )
Pilot circuit	3.9 MPa (40 kgf/cm <sup>2</sup> )

### Hydraulic Cylinders

	Quantity	Bore	Rod diameter	Stroke
Boom canopy	1	80 mm	45 mm (50)	579 mm (576)
Boom cabin	1	80 mm	45 mm (50)	563 mm (564)
Arm	1	70 mm	40 mm (45)	546 mm (597)
Bucket	1	65 mm	40 mm	435 mm
Blade	1	85 mm	45 mm (50)	135 mm (140)
Boom swing	1	85 mm	45 mm	525 mm

Figures between (...) are the data on the AX38U-7.

## SERVICE REFIL CAPACITIES

Fuel tank	42.0 L
Engine coolant	3.9 L
Engine oil	7.2 L
Travel device (each side)	0.6 L
Hydraulic system	56.0 L
Hydraulic oil tank	32.0 L

## FRONT ATTACHMENTS

### BACKHOE BUCKETS

ISO 7451 capacity	Width		No. of teeth	Weight	Front Attachment			
	Without side cutters	With side cutters			AX33u-7 arm		AX38u-7 arm	
					1.17m	1.52m	1.32m	1.72m
0.08 m <sup>3</sup>	400 mm	450 mm	3	67 kg	A	A	A	A
0.09 m <sup>3</sup>	450 mm	500 mm	4	73 kg	A	A	A	A
0.10 m <sup>3</sup>	500 mm	550 mm	4	76 kg	A	B	A	A
0.11 m <sup>3</sup>	550 mm	600 mm	4	80 kg	B	C	A	B
Arm crowd force					16.9 kN	14.6 kN	19.0 kN	16.9 kN
Bucket digging force					27.2 kN		27.1 kN	

A: General digging B: Light-duty digging C: Loading

## UPPERSTRUCTURE

### Revolving Frame

D-section frame for resistance to deformation

### Swing Device

Axial piston motor with planetary reduction gear is lubricated by hydraulic oil. Swing circle is single-low. Swing parking brake is spring-set/hydraulic-released disc type.  
Swing speed 9.1 min<sup>-1</sup> (rpm)  
Swing torque 5.1 kN·m (558 kgf·m)

### Operator's Cab

Independent spacious cabin, 1,049 mm wide by 1,611 mm high, conforming to ISO\* Standards. Reinforced glass windows on 4 sides for visibility. Front windows (upper and lower) can be opened. Reclining seat.

\* International Standardization Organization

## UNDERCARRIAGE

### Tracks

Tractor-type undercarriage. Welded track frame using selected materials. Side frame welded to track frame.

### Numbers of Rollers and Shoes on Each Side

Upper rollers	1
Lower rollers	4

### Travel Device

Each track driven by 2-speed axial piston motor. Parking brake is spring-set/hydraulic-released disc type.  
Automatic transmission system High-Low  
Travel speeds High : 0 to 4.3 km/h  
Low : 0 to 2.8 km/h  
Maximum traction force 27 kN (2,750 kgf)  
Gradeability 58% (30-degree) continuous

## WEIGHTS AND GROUND PRESSURE

AX33u-7 equipped with 2.28 m boom, 1.52 m arm and 0.08 m<sup>3</sup> bucket (ISO heaped). AX38u-7 equipped with 2.47m boom, 1.72 m arm and 0.10 m<sup>3</sup> bucket (ISO heaped).

	AX33u-7		AX38u-7	
	Operating weight	Ground pressure	Operating weight	Ground pressure

### 4-Poles Canopy version

300 mm rubber shoes	3,330 kg*	30 kPa*	3,790 kg*	34 kPa*
300 mm steel shoes	3,470 kg*	31 kPa*	3,930 kg*	35 kPa*

### Cabin version

300 mm rubber shoes	3,510 kg*	32 kPa*	3,960 kg*	36 kPa*
300 mm steel shoes	3,650 kg*	33 kPa*	4,100 kg*	37 kPa*

\* AX33u-7: including 0.08 m<sup>3</sup> (ISO heaped) bucket weight (67 kg), additional counterweight (190 kg).

\* AX38u-7: including 0.10 m<sup>3</sup> (ISO heaped) bucket weight (76 kg), additional counterweight (230 kg).

# LIFTING CAPACITIES

Notes: 1. Ratings are based on ISO 10567.

2. The lifting capacity of the AX series does not exceed 75% of the tipping load with the machine on firm, level ground or 87% full hydraulic capacity.

3. The load point is a hook (not standard equipment) located on the back of the bucket.

4. \*Indicates load limited by hydraulic capacity.

5. 0 m = Ground.

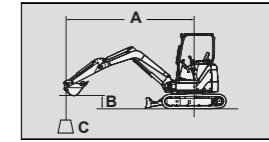

A: Load radius

B: Load point height

C: Lifting capacity

## AX33u-7 Cabin Version, Blade above Ground



Unit: 1,000 kg

Conditions	Load point height m	Load radius								At max. reach		
		1.0 m		2.0 m		3.0 m		4.0 m		meter		
		Rating over-front	Rating over-side or 360 degrees	Rating over-front	Rating over-side or 360 degrees	Rating over-front	Rating over-side or 360 degrees	Rating over-front	Rating over-side or 360 degrees			
Boom 2.28 m	3									0.57	0.44	3.97
Arm 1.52 m	2									0.48	0.37	4.39
Additional counterweight 190 kg	1					*0.86	0.67	0.55	0.43	0.48	0.37	4.39
Rubber shoe 300 mm	0 (Ground)					0.82	0.62	0.53	0.41	0.45	0.34	4.50
	-1	*1.47	*1.47	*1.48	1.06	0.78	0.59	0.52	0.40	0.47	0.36	4.33
	-2			*1.51	1.10					0.55	0.42	3.84
										0.89	0.67	2.80

## AX33u-7 Cabin Version, Blade on Ground



Unit: 1,000 kg

Conditions	Load point height m	Load radius								At max. reach		
		1.0 m		2.0 m		3.0 m		4.0 m		meter		
		Rating over-front	Rating over-side or 360 degrees	Rating over-front	Rating over-side or 360 degrees	Rating over-front	Rating over-side or 360 degrees	Rating over-front	Rating over-side or 360 degrees			
Boom 2.28 m	3									*0.62	0.44	3.97
Arm 1.52 m	2									*0.60	0.37	4.39
Additional counterweight 190 kg	1					*1.19	0.62	*0.89	0.41	*0.64	0.34	4.50
Rubber shoe 300 mm	0 (Ground)					*1.48	1.06	*1.4	0.59	*0.96	0.40	4.33
	-1	*1.47	*1.47	*2.38	1.06	*1.35	0.58			*0.9	0.42	3.84
	-2			*1.51	1.10					*0.9	0.67	2.80

## AX38u-7 Cabin Version, Blade above Ground



Unit: 1,000 kg

Conditions	Load point height m	Load radius								At max. reach		
		1.0 m		2.0 m		3.0 m		4.0 m		meter		
		Rating over-front	Rating over-side or 360 degrees	Rating over-front	Rating over-side or 360 degrees	Rating over-front	Rating over-side or 360 degrees	Rating over-front	Rating over-side or 360 degrees			
Boom 2.47 m	3							0.64	0.60	0.55	0.52	4.37
Arm 1.72 m	2									0.48	0.45	4.76
Additional counterweight 230 kg	1					*0.85	*0.85	0.63	0.59	0.48	0.45	4.76
Rubber shoe 300 mm	0 (Ground)					0.93	0.86	0.61	0.57	0.45	0.42	4.87
	-1	*1.43	*1.43	*1.42	*1.42	0.88	0.81	0.58	0.55	0.46	0.43	4.73
	-2	*2.40	*2.40	1.66	1.49	0.87	0.80	0.58	0.54	0.52	0.49	4.31
				1.69	1.52	0.88	0.81			0.72	0.67	3.48

## AX38u-7 Cabin Version, Blade on Ground



Unit: 1,000 kg

Conditions	Load point height m	Load radius								At max. reach				
		1.0 m		2.0 m		3.0 m		4.0 m		meter				
		Rating over-front	Rating over-side or 360 degrees	Rating over-front	Rating over-side or 360 degrees	Rating over-front	Rating over-side or 360 degrees	Rating over-front	Rating over-side or 360 degrees					
Boom 2.47 m	3							*0.71	0.60	*0.64	0.52	4.37		
Arm 1.72 m	2									*0.63	0.45	4.76		
Additional counterweight 230 kg	1					*1.25	0.86	*0.93	0.57	*0.67	0.42	4.87		
Rubber shoe 300 mm	0 (Ground)					*1.42	*1.42	*1.54	0.81	*1.05	0.55	*0.76	0.43	4.73
	-1	*1.43	*1.43	*2.34	1.49	*1.56	0.80	*1.04	0.54	*0.91	0.49	4.31		
	-2	*2.40	*2.40	*2.17	1.52	*1.26	0.81			*0.95	0.68	3.48		



# DIMENSIONS & WORKING RANGES

## ● DIMENSIONS & WORKING RANGES

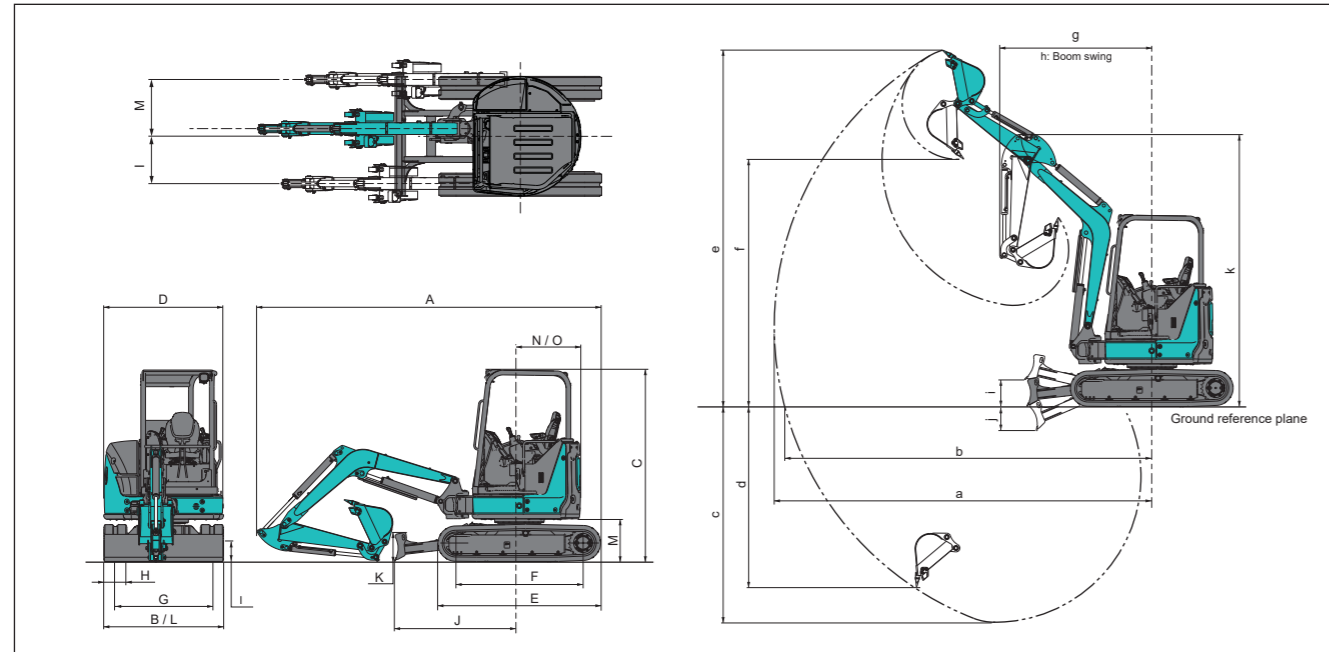

## ● DIMENSIONS & WORKING RANGES

Unit: mm

Item		Model		AX33u-7		AX38u-7		AX48u-7		AX55u-7				
Shoe type		Rubber shoe												
Roof type		Canopy		Cabin		Canopy		Cabin		Canopy		Cabin		
DIMENSIONS	A: Max. Transport length	mm	4,530 (4,450)		4,760 (4,640)		5,390 (5,350)		5,520 (5,470)					
	B: Undercarriage width	mm	1,550		1,740		1,960		2,000					
	C: Overall height	mm	2,480		2,480		2,530		2,530					
	D: Upperstructure width	mm	1,550		1,550		1,850		1,850					
	E: Undercarriage length	mm	2,110		2,110		2,500		2,500					
	F: Sprocket center to idler center	mm	1,660		1,660		2,000		2,000					
	G: Distance between undercarriage cent	mm	1,250		1,440		1,560		1,600					
	H: Track shoe width	mm	300		300		400		400					
	I: Min. Ground clearance	mm	280		280		340		340					
	J: Parallel blade distance	mm	1,620		1,620		1,820		1,820					
	K: Blade height	mm	360		360		375		375					
	L: Blade width	mm	1,550		1,740		1,960		2,000					
	M: Counterweight clearance	mm	550		550		610		610					
	N: Rear edge length	mm	875		980		1,080		1,100					
	O: Rear edge swing radius	mm	875		980		1,080		1,100					
WORKING RANGES	a: Max. digging reach	mm	5,170 (4,890)		5,520 (5,210)		6,060 (5,760)		6,260 (5,960)					
	b: Max. digging reach at ground	mm	5,040 (4,750)		5,410 (5,080)		5,920 (5,610)		6,130 (5,820)					
	c: Max. digging depth	mm	3,130 (2,790)		3,460 (3,060)		3,630 (3,320)		3,830 (3,530)					
	d: Max. vertical wall	mm	2,530 (2,330)		2,780 (2,580)		2,880 (2,550)		3,140 (2,810)					
	e: Max. cutting height	mm	4,700 (4,620)	4,470 (4,420)	4,950 (4,870)	4,740 (4,700)	5,820 (5,590)	6,000 (5,750)						
	f: Max. dumping height	mm	3,310 (3,200)	3,100 (3,030)	3,570 (3,460)	3,390 (3,310)	4,140 (3,910)	4,310 (4,070)						
	g: Min. swing radius	mm	2,090 (1,970)	2,180 (2,150)	2,190 (2,080)	2,300 (2,240)	2,370 (2,240)	2,300 (2,210)						
	h: Max. boom swing radius	mm	1,680 (1,580)	1,860 (1,820)	1,770 (1,670)	1,970 (1,910)	1,860 (1,750)	1,810 (1,730)						
	i: Blade bottom highest position	mm	360		360		460		460					
	j: Blade bottom lowest position	mm	320		400		365		365					
	k: Front height at min. swing radius	mm	3,560 (3,530)	3,460 (3,440)	3,760 (3,720)	3,680 (3,640)	4,250	4,380						
	l/m: Offset distance	mm	610/735	610/700	610/735	610/700	690/850	690/850						
Max. Boom-swing angle	deg.	72/62	62/62	72/62	62/62	80/60	80/60							

Figure in ( ) show the machine equipped with a standard arm.

# EQUIPMENT

Standard and optional equipment may vary by country, so please consult your AIRMAN dealer for details.

## ● STANDARD EQUIPMENT

### ENGINE

- Auto idle system
- Cartridge-type engine oil filter
- Electrical fuel feed pump
- Fuel main filter
- Radiator reserve tank
- Water-separator for engine fuel

### HYDRAULIC SYSTEM

- Boom anti-drift valve
- Fuel-flow filter
- Hydraulic pilot type control levers
- Pilot control shut-off lever with neutral engine start system

- Pilot filter
- Suction filter
- Swing parking brake
- Travel parking brake
- Two-speed travel system
- Valve for extra piping

### CABIN

- Air conditioner
- AM/FM radio
- Anti-slip plate
- Armrests
- Defroster
- Drink holder
- Electric horn
- Floor mat
- Reclining seat
- Retractable seat belt
- ROPS/OPG cab
- Spare power supply
- Suspension seat
- Window washer
- Wiper

### FRONT ATTACHMENTS

- HN bushing
- Extra piping
- 1.52 m long arm (AX33U-7)
- 1.72 m long arm (AX38U-7)
- 1.69 m long arm (AX48 to AX55U-7)

### 4-POLE CANOPY

- Anti-slip plate
- Armrests
- Drink holder
- Electric horn
- Floor mat
- Reclining seat
- Retractable seat belt
- ROPSD/OPG canopy
- Spare power supply
- Suspension seat

### UPPERSTRUCTURE

- Rear view mirror
- Tool box (AX48 to AX55U-7)
- 190 kg additional counter-weight (AX33U-7)
- 230 kg additional counter-weight (AX38U-7)
- 200 kg additional counter-weight (AX48 to AX55U-7)
- Auxilliary overload relief valve (ORV)

### UNDERCARRIAGE

- 300 mm rubber shoe (AX33 to AX38U-7)
- 400 mm rubber shoe (AX48 to AX55U-7)

## ● OPTIONAL EQUIPMENT

### ENGINE

- Dust-Proof indoor net

### HYDRAULIC SYSTEM

- Hose rupture valve (HRV)

### CABIN

- Auxiliary function lever (AFL)
- Heater

### 4-POLE CANOPY

- Auxiliary function lever (AFL)

### FRONT ATTACHMENTS

- Assist piping
- 1.17 m STD arm (AX33U-7)
- 1.32 m STD arm (AX38U-7)
- 1.38 m STD arm (AX48 to AX55U-7)

### UPPERSTRUCTURE

- Auxiliary overload relief valve (ORV)
- Pilot accumulator
- Stack muffler

### UNDERCARRIAGE

- 300 mm grouser shoe (AX33 to AX38U-7)
- 300 mm pad crawler shoe (AX33 to AX38U-7)
- 400 mm grouser shoe (AX48 to AX55U-7)
- 400 mm pad crawler shoe (AX48 to AX55U-7)

### MISCELLANEOUS

- Theft deterrent system\*

\*Hokuetsu Industries cannot be held liable for theft, any system will just minimize the risk of theft.



# The Airman family from 1.100 kg to 5.500 kg



## SAFETY

- Operate safely in accordance with the proper operation manual.
- To prevent trouble and accidents, make sure to perform daily and preventive maintenance checks.

# AIRMAN®

## HOKUETSU INDUSTRIES EUROPE B.V.

Aalsmeerderdijk 156 unit J, 1438 AX, OUDE MEER, The Netherlands

Tel : +31-(0)20-646-2636 Fax : +31-(0)20-646-2191

e-mail : [info@hokuetsu.nl](mailto:info@hokuetsu.nl)

URL : <http://www.hokuetsu.eu>

---

**DISTRIBUTOR**