

KANGA "A" SERIES COMPACT SKID STEER LOADERS

OPERATORS MANUAL KANGA A 5-6-7 SERIES



REVISION TABLE

Revision	Date	Page #	Changes Made	Changes By
1.0	Sept 2007	All	Manual Update	A.B.
2.0	Jan 2008	All	Cover & Headers	A.B.
2.1	Jan 2008	6/7	Foreword	A.B.
2.2	Jun 2008	33/34	Service Chart & Info	A.B.
2.3	Jul 2008	11	1300 4 KANGA	A.B.
2.4	Aug 2008	35	Diesel Fuel Filter	A.B.
2.5	Dec 2008	33/34	Service Chart	A.B.
2.6	Dec 2008	4	NZ Address	A.B.



DELIVERY SHEET

Owner:	Date:											
Address:												
City:	Post Code:											
State/Territory:	Email Address:											
Owners Phone No: ()	Mobile:											
Dealer / Delivered By:												
Loader Model and Serial No:												
Attachments:	Serial No.											
(1)												
(2)												
(3)												
(4)												
(5)												
<p>I (Customer's name)</p> <p>1. Accept delivery of the equipment as detailed above. All equipment has been inspected and is accepted.</p> <p>2. Have had the operational and safety procedures explained to me for the Loader and attachments and have been provided a copy of these procedures for reference and use.</p> <p>3. Have received a copy and understand the Operators Manual and safety information contained therein for all equipment and attachments supplied.</p> <p>4. Understand that I am required to perform a risk assessment/JSEA covering all tasks before I operate this machine and/or any attachment.</p> <p>5. Understand the warranty conditions and maintenance requirements for the Loader and attachments.</p> <p>Comments:</p> <p style="text-align: center;">(COMPLETE SERIAL NUMBER REGISTRATION ON PAGE 29)</p> <p>Purchaser's Signature:</p> <p>.....</p>		<p>Salesman / Owner to initial</p> <table border="1" style="width: 100%; height: 20px; margin-bottom: 5px;"> <tr> <td style="width: 50%;"></td> <td style="width: 50%;"></td> </tr> </table> <table border="1" style="width: 100%; height: 20px; margin-bottom: 5px;"> <tr> <td style="width: 50%;"></td> <td style="width: 50%;"></td> </tr> </table> <table border="1" style="width: 100%; height: 20px; margin-bottom: 5px;"> <tr> <td style="width: 50%;"></td> <td style="width: 50%;"></td> </tr> </table> <table border="1" style="width: 100%; height: 20px; margin-bottom: 5px;"> <tr> <td style="width: 50%;"></td> <td style="width: 50%;"></td> </tr> </table> <table border="1" style="width: 100%; height: 20px;"> <tr> <td style="width: 50%;"></td> <td style="width: 50%;"></td> </tr> </table> <p>Date:</p> <p>..... / /</p>										
<p>FORWARD AS INDICATED OVERLEAF.</p>												



WARRANTY SHEET

Read the Warranty section towards the rear of this manual before completing the Warranty Registration Form below. Once read, complete and return within 30 days of the delivery date to the address as indicated adjacent to the respective country of purchase as indicated on the Warranty Registration Form.

KANGA LOADERS: WARRANTY REGISTRATION FORM

Owner:	Phone: ()
Address:	Mobile:
Town/City:	Fax: ()
Country:	Post Code:
Delivery Date:	KANGA Serial No:
Email:	
Dealer:	

I (The Purchaser) have read and fully understand the Operator's Manual, Safety Instructions and warranty conditions.

Warranty will only be accepted if this Certificate is completed and returned to:
Australia:
KANGA LOADERS Pty. Ltd, PO Box 54, Burleigh Heads, Queensland, 4220.

New Zealand:
PO Box 10320, Te Rapa Hamilton 3241.

South Africa:
KANGA LOADERS SA, PO Box 105, Swellendam, 6740.

United Kingdom:
KANGA LOADERS U.K., Unit 70 The Warren, East Goscote Ind. Estate, East Goscote, Leischester, LE7 3XA.

Within 30 days of the delivery date.

Purchaser's Signature: 	Date: / /
-------------------------------------	------------------------------------



LOADER CHECKLIST

MODEL: _____

INSPECTOR'S NAME: _____

SERIAL No.: _____

MACHINE BUILT BY: _____

ENGINE No.: _____

DATE: _____

Visual Checks			Operational Checks		
	√	x		√	x
1. Damage			1. Gauges/switches and connections/dash lights		
2. Loose bolts/nuts			2. Attachment Plate		
3. Rust			3. Throttle Lever (not too tight or loose)		
4. Leakage oil or water			4. Levers and linkages (Aux Stop Cable adjustment)		
5. Wiring / oil cooler connection			5. Unusual noises or vibrations		
6. Paint work			6. Petrol engine Idle 1350-1450 RPM		
7. Any untidy weld spots or runs			7. Petrol engine max 3550-3650 RPM		
8. Check of fittings alignment			8. Is Loader easy to start?		
9. Is Loader clean and tidy?			9. Is Hour Meter working? Test time = _____ hrs		
10. Are pipes and hoses clear of parts on Loaders?			10. Check that lift cylinder stops in correct position		
11. Are Hershel plugs clear of tank & hydraulic lift tubes?			Guidance √ x		
Service √ x			1. Correct stickers applied (UK C/E sticker)		
1. Tie down lugs fitted on body			2. Correct Tyre Pressure sticker attached		
2. Correct Attachment Plate/ operation ok with test jig			3. Identification Plate -(correct number stamped)		
3. Lubricate Loader, grease all linkages			4. Safety/Operating Manual		
4. All pins and bushes fitted and tight			5. Safety/Operating DVD		
5. Belt tension fan/alternator			6. Engine Manual (Kubota or Honda Warranty Form)		
6. Wheel condition/wheel nuts been tensioned 100 ft-lb			Fluid Compartment Check √ x		
7. Is the track slot forward and tyre direction correct?			1. Battery condition		
8. Is the tyre pressure to specification?			2. Engine oil level		
9. Radiator core, hoses and fittings			3. Hydraulic oil level		
10. Air element and hose clearance and connections tight			4. Fuel level		
11. Sediment in fuel filter/tank (drain fuel tank)			5. Inspect fuel tanks for leaks		
12. Is engine EPA compliant?			6. Radiator water level (Diesel engine)		
13. Is PTO direction correct?			7. Hydraulic filter housing directions and elements tight		
14. Has valve tag been removed?			Other √ x		
15. Are QRCs correctly aligned and covers fitted?			1. Is the "Passed By" sticker attached and signed?		
16. Spare key fitted correctly to machine			2. Check machine to be shipped against order		
17. Ensure battery is secure and boot is on alternator			3. Is the Loader ready for despatch?		
18. 8 Series U-Beaut bracket stop bolt fitted			4. Ensure diesel Loader has oil funnel		
19. Is the Splash Plate fitted?			5. Have back protection bars been ordered and fitted?		
20. Check oil cooler connection to fan					
21. Ensure control knobs are not split and are secured					
22. Is the Control Knob on Trencher Valve clear of guard?					

CUSTOMER'S COMMENTS: _____

INSPECTOR'S COMMENTS: _____

"Received the above Loader, attachments and documentation as stated above in good condition. The correct operation of the Loader has been explained to our satisfaction. We understand that this Loader should be operated by a properly trained operator. We are aware that the use of this Loader in any manner or place for which it is not designed will render it unsafe."

DISTRIBUTOR'S NAME: _____

INSPECTOR'S SIGNATURE: _____

FOREWORD



We thank you for choosing the KANGA LOADER. This machine is the result of extensive design and development, and is acknowledged as being a superior product in its category. We congratulate you on your discerning choice and wish you many years of productive service.

Read this manual carefully before operating your machine it contains important technical information, safety precautions and operating instructions. Compliance with Safety Precautions and Risk Management standards together with the correct operation and attention to maintenance procedures are necessary to ensure a long, SAFE and trouble free working life for your KANGA LOADER.

Some illustrations in this publication show details or attachments that may be different from your machine. Guards and covers may have been removed for illustrative purposes, however, the machine in its operational state must always be operated with all guards and safety controls in place.

Continuing improvement and advancement of product design may have caused changes to your machine which are not included in this publication. We advise you to read, study and understand this manual before undertaking any maintenance, and to keep it with your machine at all times as a ready reference.

SAFETY

The safety section lists basic safety precautions. In addition, this section identifies the text and locations of warning labels used on the machine.

Read and understand the basic precautions listed in the safety section before operating or performing lubrication, maintenance and repair on this product.



Proprietary Statement

© Copyright 2006 Jaden Kanga Group Pty Ltd. All rights reserved. No part of this publication may be reproduced, photocopied, stored on a retrieval system, or transmitted without the express prior written consent of the publisher.

Disclaimer

While all care has been taken in the development of this product, no loss of any kind is accepted by Jaden Kanga Group Pty Ltd or its agents arising from the use of this document.

Jaden Kanga Group Pty Ltd makes no representations or warranties with respect to the contents of this document, and specifically disclaims any express or implied warranties or fitness for any particular purpose. Further, Jaden Kanga Group Pty Ltd reserves the right to revise this publication and to make changes to its contents, at any time, without obligation to notify any person or entity of such revisions or changes.

Trademarks

Jaden Kanga Group PTY LTD (ACN 010 875 868, ABN 40 010 875 868) 2007 ("we", "us")

™ Trade mark of Jaden Kanga Group Proprietary Limited.

© Australia Registered trade mark of Jaden Kanga Group Jaden, The Kangaroo Device, Platypus, Kanga Loaders, Kanga Kid, Earth Power.

™ Business on a Trailer, Kanga.

© Jaden Kanga Group

1 Copyright

1.1 kanga-loader.com, the material on kanga-loader.com, the software, design, text and graphics comprised in kanga-loader.com and the selection and layout of kanga-loader.com are owned or licensed by us and protected by copyright under the laws of Australia and other countries.

1.2 You may view this website and its contents using your web browser and save an electronic copy of the website solely in the usual operation of your web browser in visiting the site.

1.3 You must not otherwise reproduce, transmit (including broadcast), adapt, distribute, sell, modify or publish or otherwise use any of the material on the site, including audio and video excerpts, except as permitted by statute or with Jaden Kanga Group's prior written consent.

2 Trade Mark Notice

This site includes registered trade marks and trade marks which are the subject of pending applications or which are otherwise protected by law including, but not limited to the word KANGA LOADERS, the Kanga Loaders logo, the Jaden Kanga Group Logo. You may not use these trade marks or the names "Jaden Kanga Group Proprietary Limited", "Kanga Loaders Australia Proprietary Ltd" or "Kanga Loaders" or the name of any of our related companies.

3 Framing

You must not frame any of the material appearing on kanga-loader.com except in accordance with Jaden Kanga Group's Linking and Framing Policy or otherwise in accordance with Jaden Kanga group's prior written consent.

©Jaden Kanga Group Proprietary. All rights reserved.

Patents

Patents Pending US 6397967, 438218 & 10/096997 AU 65424/99, 2006101054
UK 2345046. AU Registered Design 138603

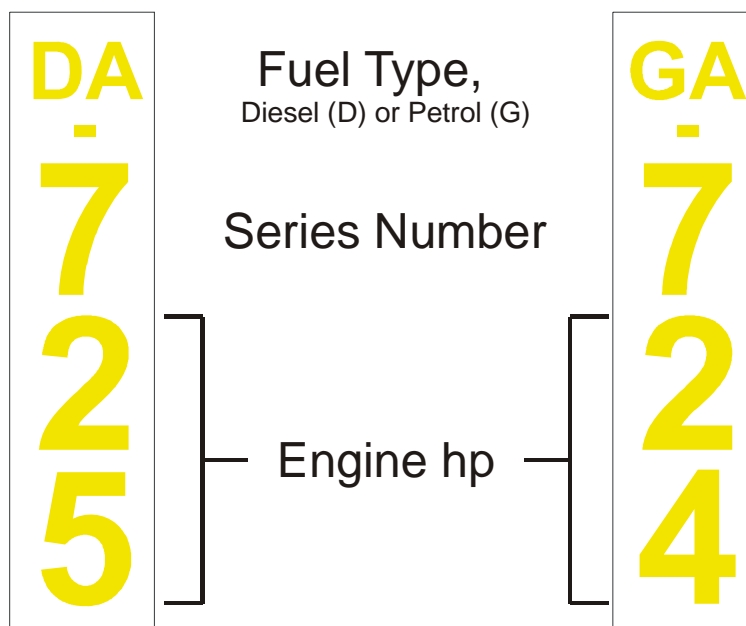



TABLE OF CONTENTS

REVISION TABLE	2
DELIVERY SHEET	3
WARRANTY SHEET	4
LOADER CHECKLIST	5
FOREWORD	6
TABLE OF CONTENTS	8
SAFETY	10
HOW TO CONTACT US	11
<i>safety</i>	12
PREPARATION FOR USE.....	12
SAFE OPERATION.....	13
SAFETY - Summary	16
NO GO ZONES FOR UNDERGROUND UTILITY SERVICES	17
SAFE - JOB SAFETY CHECK SHEET	18
TASK PLANNING FOR THE KANGA LOADER	19
RISK RANKING CHART.....	20
JOB SAFETY CHECK.....	21
SAFETY - Rules for Attachments.....	22
<i>operating instructions</i>	26
OPERATING INSTRUCTIONS.....	26
SERIAL NUMBER REGISTRATION.....	29
<i>maintenance</i>	30
DAILY OPERATOR MAINTENANCE	30
LOADER ARM MAINTENANCE	31
OPERATOR MAINTENANCE - SAFETY CHECKS	32
SERVICE CHART	33
SERVICE TASKS	34
SERVICE TASKS - Engine	35
SERVICE TASKS - Hydraulics	37
SERVICE TASKS - Grease Nipple.....	39
SERVICE TASKS - Tyre Pressure	40
SERVICE TASKS - Battery	40
SERVICE TASKS - Visual	40
SERVICE TASKS - Pivot Pins.....	41
TROUBLESHOOTING	42



tracks 46

TRACKS (Series 7 only) – Safety/Parts.....46

TRACKS INSTALLATION47

TRACK ORIENTATION OPTION49

TRACK CHAIN LINK REMOVAL.....52

spare parts..... 53

HOW TO ORDER SPARE PARTS.....53

DECALS54

DRIVE TRAIN - ASSEMBLY DRAWING55

DRIVE TRAIN - PARTS LIST56

MAIN FRAME - ASSEMBLY DRAWING57

MAIN FRAME - PARTS LIST58

ARMS - ASSEMBLY DRAWING59

ARMS - PARTS LIST60

PETROL ENGINE & HYDRAULICS - ASSEMBLY DRAWING.....61

PETROL ENGINE & HYDRAULICS - PARTS LIST62

DIESEL ENGINE & HYDRAULICS - ASSEMBLY DRAWING63

DIESEL ENGINE & HYDRAULICS - PARTS LIST64

HYDRAULIC CONNECTIONS – SCHEMATIC65

HYDRAULIC CONNECTIONS - Series 5, 6 & 766

specification 67

SPECIFICATIONS - 5 Series.....67

DIMENSIONS - 5 Series68

SPECIFICATIONS - 6 Series.....69

DIMENSIONS - 6 Series70

SPECIFICATIONS - 7 Series.....71

DIMENSIONS - 7 Series72

attachments 73

HYDRAULIC ATTACHMENT CONNECTIONS73

POWER HEAD OPERATING INSTRUCTIONS74

TRENCHER OPERATING INSTRUCTIONS75

warranty 76

WARRANTY: 1 YEAR OR 1,000 HOURS.....76

SPARE PARTS WARRANTY: 6 MONTHS77

appendices..... 78

FIVE STEPS TO EFFECTIVE JSEA78

JOB SAFETY AND ENVIRONMENTAL ANALYSIS WORKSHEET79

SAFETY

The safety section lists safety precautions **required** to be taken when operating or maintaining a Kanga Loader. Read and follow **all** operating and safety instructions contained in this Manual and illustrated on the decals fitted to the Loader, and ensure that you assess the risk of any task by use of the attached Job Safety & Environmental analysis (JSEA) sheet.

If you are unable to identify hazards or do not understand the process for use of the JSEA chart, stop the job and consult a qualified Occupational Health and Safety consultant.



This Symbol has been used throughout this manual to highlight **critical** safety information to prevent death and injury.



This symbol has been used throughout this manual to highlight important safety information. Ensure you read and understand the information before embarking on any related task.



These symbols are pictograms and refer to compulsory Personal Protective Equipment (PPE) that must be worn and/or actions that must be taken by the operator to allow safe operation of the machine to occur.



HOW TO CONTACT US

Head Office

Phone: Aus: (07) 5593 4567
Int: +61 7 5593 4567

Fax: Aus: (07) 5593 4398
Int: +61 7 5593 4398

Email: australia@kanga-loader.com

Postal: Jaden-Kanga Group Pty Ltd
PO Box 54
Burleigh Heads
Queensland 4220
Australia.

Address: Jaden-Kanga Group Pty Ltd
43 Alex Fisher Drive
Burleigh Gardens Industrial Park
Gold Coast
Queensland 4220
Australia.

Sales

Phone **1300 4 KANGA (1300 4 52642)**

Spares & Mechanical Support

Phone: Aus: 1300 784 223
Int: +61 7 5593 4567

Fax: Aus: (07) 5546 7922
Int: +61 7 5546 7922

Email: australia@kanga-loader.com

Operating Tips & Support

Phone: Aus: 1300 784 223
Int: +61 7 5593 4567

Visit Our Website

www.kanga-loader.com

Safety & Risk Management Support

Safety & Forensic Engineering Pty Limited
Phone: +61 2 4933 9942
Email: safegroup@safegroup.com.au



safety

PREPARATION FOR USE

INSPECTION AFTER DELIVERY

When the machine is delivered, it should be inspected for any evidence of damage caused as a result of shipment before it is declared ready for use. The preparation of the mini loader for use should only be undertaken by a responsible person who has read and understood this manual. The requirements are simple and coupled with the use of good common sense, together with general occupational health and safety knowledge and a visual inspection, should not pose any problems. The following checklist provides suggestions for detecting defective or damaged parts.

CHECK BEFORE USE

1	Inspect the machine chassis for any visible damage.
2	Visually inspect all components to ensure they are attached securely.
3	Inspect all areas for evidence of hydraulic oil, engine oil or fuel leakage.
4	Inspect Arm assembly area for firm attachment and sufficient lubrication. Check hydraulic cylinders for oil leakage and visible damage.
5	Check hydraulic oil lines for correct connection and for signs of leakage.
6	Check wheel and tyre assemblies for loose or missing wheel nuts, any visible damage and proper tyre inflation.
7	Check wheel drive motor assemblies for any visible damage and oil leakage.
8	Inspect all cylinders for rust, nicks, scratches or foreign material on shafts. Check for hydraulic oil leaks at the seal and fitting areas.
9	Inspect the engine compartment for loose or missing components and any evidence of damage or leakage.
10	Check the hydraulic fluid level is within operating limits as marked on the Sight Gauge.
11	Check the engine oil level is within operating limits as marked on the Dip Stick.



SAFE OPERATION

The Kanga Loader is a versatile machine, capable of performing a variety of tasks in a safe and effective manner, when used in accordance with established procedures and supported by Risk Assessment. However, to ensure the safety of operators and others, it is important to ensure that the capacity of the machine is not exceeded and that the Loader is operated appropriately, and only after all tasks associated with the work at hand have been documented and the relevant risk control measures implemented.

To ensure the safe operation and transport of your Kanga Loader, the following basic Safety Rules must be understood and complied with at all times.

Safe Loading/Unloading and Transportation:

- When loading/unloading the Kanga from a trailer, it is important that the trailer remains attached to the towing vehicle on a firm even surface.
- Never unload a trailer positioned on a slope.
- Ensure the angle of ascent/descent is within safe operational limitations.
- Ensure bystanders are sufficiently clear.
- All loading/unloading is to be carried out at a slow speed with due care for personal safety and damage to equipment. Practice the manoeuvres first on flat ground if necessary.
- When lifting the machine, use appropriately rated slings and shackles and attach securely to the lifting point on the top of the machine.
- Always use the tie down points on each side of the machine to secure the Loader when transporting.
- Always use witches hats, signage and traffic signals to control the unloading/loading zone, particularly when in close proximity to operational roads.

Before Commencing Work:

- Ensure all safety instructions are clearly understood, that operating manuals have been read and that operators are familiar with the controls of the Kanga Loader.
- Ensure that the daily inspection routine has been successfully conducted. It is particularly important to ensure that all attachment Locking Pins are fully engaged and secure.
- Ensure the driving platform is free from dirt, grease or mud before use.
- Check all controls for proper response. Shut down the machine if a fault is detected, tag the machine out with an 'Out of Service' tag, remove the key and contact the local Service Agent.
- Review the working site for hazards through the use of a Job Safety Analysis and/or Risk Assessment and implement the risk control measures to eliminate or minimise their effects, such as:
 - **Overhead power lines**
 - **Underground services**
 - **Excavations**
 - **Slopes or adverse cambers**
 - **Confined spaces**
 - **Other obstructions**
 - **Other people or animals accessing the working area or machine**

ALWAYS...

- Completely read and understand the Operator's Manual supplied with the machine.
- Undertake a Job Safety and Environmental Analysis (JSEA) and/or Risk Assessment before any use of both the Kanga Loader and the trailer upon which the Loader and/or attachments are carried. A blank JSEA is provided in Appendix A for use. Photocopy as required.
- Use the Job Safety and Environmental Analysis Checklist to check that the relevant safety procedures are in place before work commences.
- Position the trailer carrying the Kanga in an area free from traffic, establish a traffic control plan/zone, chock the wheels and ensure that people are not placed in a position where they can be struck by vehicles or equipment being loaded or unloaded.
- Demarcate the work area with barricades and/or witches hats before using the Kanga Loader.
- Identify, mark and delineate all underground services before any work commences.
- Have both feet planted firmly on the driving platform at all times when operating the Kanga Loader. This is especially important when carrying loads, as body weight provides additional counter-balance to the bucket load.
- Come to a complete stop before changing direction from forward to reverse and vice versa. Failure to do so can affect the stability of the Loader and may also damage the drive of your machine.
- Come to a complete stop before operating other hydraulic controls.
- Reverse down slopes at slow speed when carrying loads.
- Ensure the machine is fully stopped and turned off before alighting or exiting the machine. Never use control levers as hand holds, instead utilize the handholds, using the thumbs and forefingers to operate the control levers.
- Travel at speeds suitable for the conditions and as determined by the task **JSEA** or Risk Assessment.
- When traveling over undulating surfaces and/or rough terrain, it is essential that the operator ensures that the speed is appropriate to suit conditions and to creep over uneven terrain at minimum speed. The recommended normal operating speed is between 2/3 to 3/4 throttle; at a lower speed the noise levels are reduced to both the operator and bystanders.
- Wear approved, appropriate Personal Protective Equipment (PPE), such as:
 - hearing protection,
 - safety footwear,
 - eye protection,
 - hard hat,
 - long, close fitting protective clothing, and
 - a high visibility vest or clothing, etc.
- Keep hands, feet and clothing away from all moving parts, including hydraulic rams.
- Keep body parts within the confines of the machine.
- Keep alert, and avoid being distracted whilst operating the Loader.
- Remove the key and chock the wheels whenever the Loader is to be left unattended and/or unsupervised.



NEVER...

- Operate this machine or the trailer without undertaking a Risk Assessment or JSEA.
- Operate this machine without Personal Protective Equipment (PPE).
- Exceed the Safe Working Load (SWL) of 250kg (551lbs) for the 5 Series and 260kg (573lbs) for the 6 and 7 Series.
- Carry passengers on any part of the Loader or attachments.
- Place feet under the driving platform.
- Smoke (or approach the Loader with a naked flame) whilst operating or refuelling.
- Leave the engine running whilst refuelling.
- Tie or secure yourself to any part of the machine or attachment.
- Fool around while operating the Loader or attachments.
- Carry a load with the bucket raised. Carry all loads as close to the ground as practicable.
- Traverse across slopes, especially on uneven ground.
- Jerk the control levers. Always use a steady, even action to achieve proper control.
- Touch exhaust, engine parts, hydraulic pipes and fittings, drive chains, friction parts or guards.
- Park or leave Loader unattended on a slope.
- Remove safety decals.
- Remove safety guarding.
- During operation use mobile telephones or portable radios.
- Operate machine for extended periods at full throttle.

**CAUTION**

Always exercise care when operating on slopes. The Kanga Loader has been designed to be able to access restricted areas, due to its minimal width. This, however, reduces its stability when crossing slopes.

The Kanga Loader is designed to operate on slopes to a maximum of 20°, under no circumstance is this to be exceeded. The actual safe slope angle may need to be reduced depending on a number of variables, such as site conditions, attachments, condition and configuration of machine and operator experience.

Crossing slopes should be avoided wherever possible. If it is not possible, slopes should be traversed with loads lowered as far as possible, reduced speed and extreme caution.

SAFETY - Summary



1. READ OPERATORS MANUAL PRIOR TO USE



2. DAILY INSPECTION

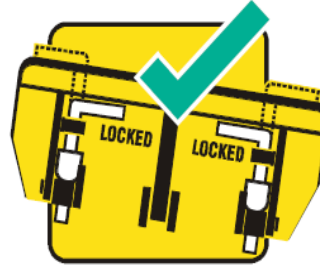

3. ENSURE BOTH (2) ATTACHMENT LOCK PINS ARE FULLY ENGAGED



4. ENSURE HYDRAULIC HOSES ARE CLEAN AND ATTACHED



5. TRANSPORT MATERIAL WITH BUCKET DOWN AND LEVEL



6. ALWAYS REVERSE DOWN SLOPES



7. WEAR APPROPRIATE PROTECTION

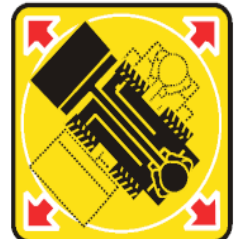

8. NO PERSONNEL WITHIN A 4M (12 ft.) DIAMETER



9. NO SMOKING WHILE FILLING



10. DO NOT PLACE FEET UNDER STANDING PLATFORM



11. DO NOT TRAVEL WITH ARMS RAISED



12. AVOID TRAVELLING ACROSS SLOPES



13. NO PERSONNEL IN BUCKET OR ATTACHMENTS



14. PAY ATTENTION



15. OPTIMUM OPERATION OF THIS MACHINE IS ACHIEVED AT 2/3 TO 3/4 THROTTLE

DANGER

FAILURE TO READ THESE SAFETY RULES PRIOR TO ANY MACHINE OPERATIONS MAY LEAD TO SERIOUS INJURY, PROPERTY DAMAGE OR DEATH

Patents US: 358497 431574
Registered Design: AU 119802 UK 2036206

NO GO ZONES FOR UNDERGROUND UTILITY SERVICES

No work is to commence on any worksite until you have checked if it contains underground services. Here is how you can find out.

- The “Dial Before You Dig” service (in Australia), **dial 1100**, provides free and easy access to the records of a large number of organizations, including telecommunications, water, electricity and gas.
- To see a list of organizations registered with the service or to log an enquiry electronically, visit the Dial Before You Dig website at www.dialbeforeyoudig.com.au, or telephone 1100 (otherwise consult with your local environment department).

If underground services are present, you must comply with the No Go Zones.

If the worksite contains or is suspected to contain ANY underground services, before any work commences, you must follow the relevant No Go Zone safety procedures:

- No Go Zone safety procedures are available from all gas, water, telecommunications and electricity companies.
- You must follow these safe systems of work at all times. If you cannot comply with these safety procedures, then NO work shall be undertaken without written permission being received from the utility company.
- The Kanga Loader and attachments must be kept a minimum distance of 2 meters from all underground services.

Maintain a Minimum of 2 meters distance from ANY Underground Service.

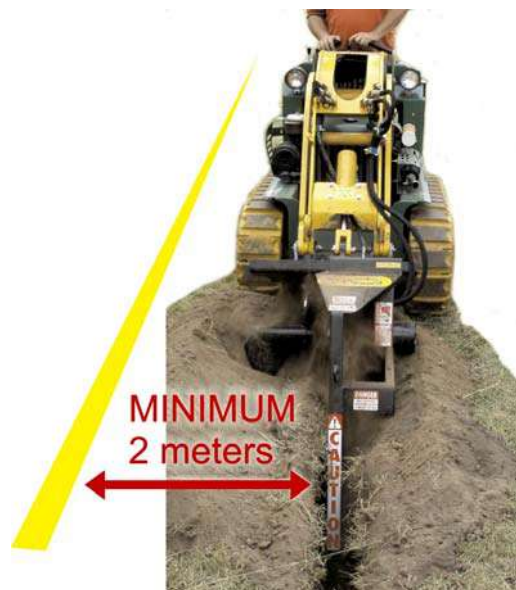



SAFE - JOB SAFETY CHECK SHEET

To ensure you work safely with Kanga Machines - carry out these checks and questions **BEFORE** you start. Use a blank copy of the JSEA in Appendix A to assist you to keep T.R.A.C.K. of the process.

Think through the Task

- Think about each step in the task/s
- Permits and authorizations needed to work
- Equipment and tools that are to be used
- The area in which you are to operate the machine and attachments

Recognise the Hazards

- Check your environment is safe
- Undertake your Daily Operator Maintenance Safety Checks
- Check equipment and tools are safe and fit for purpose
- Identify any hazards using the Job Safety and Environmental Analysis Worksheet (JSEA)
- Identify and isolate underground services
- Check above and below for potential hazards
- Determine exclusion zone and delineate with witches hats

Assess the Risks

- Could a serious injury or accident be avoided?
- What equipment/systems could be damaged?
- What is the likelihood and consequence?
- What needs to happen to reduce the risk?

Control the Hazards

- Eliminate (remove the hazard)
- Substitute (use tracked machine with low centre of gravity)
- Engineering (guards, covers, handrails)
- Administrative (SOP's, permits, signage)
- Correct PPE (hearing protection, glasses, gloves)

Keep Safety First in all Tasks

- Check for changes in work conditions (slope)
- Monitor safety controls for effectiveness
- If the Task changes, reassess Safety/Risks
- Look after yourself and your mates

TASK PLANNING FOR THE KANGA LOADER

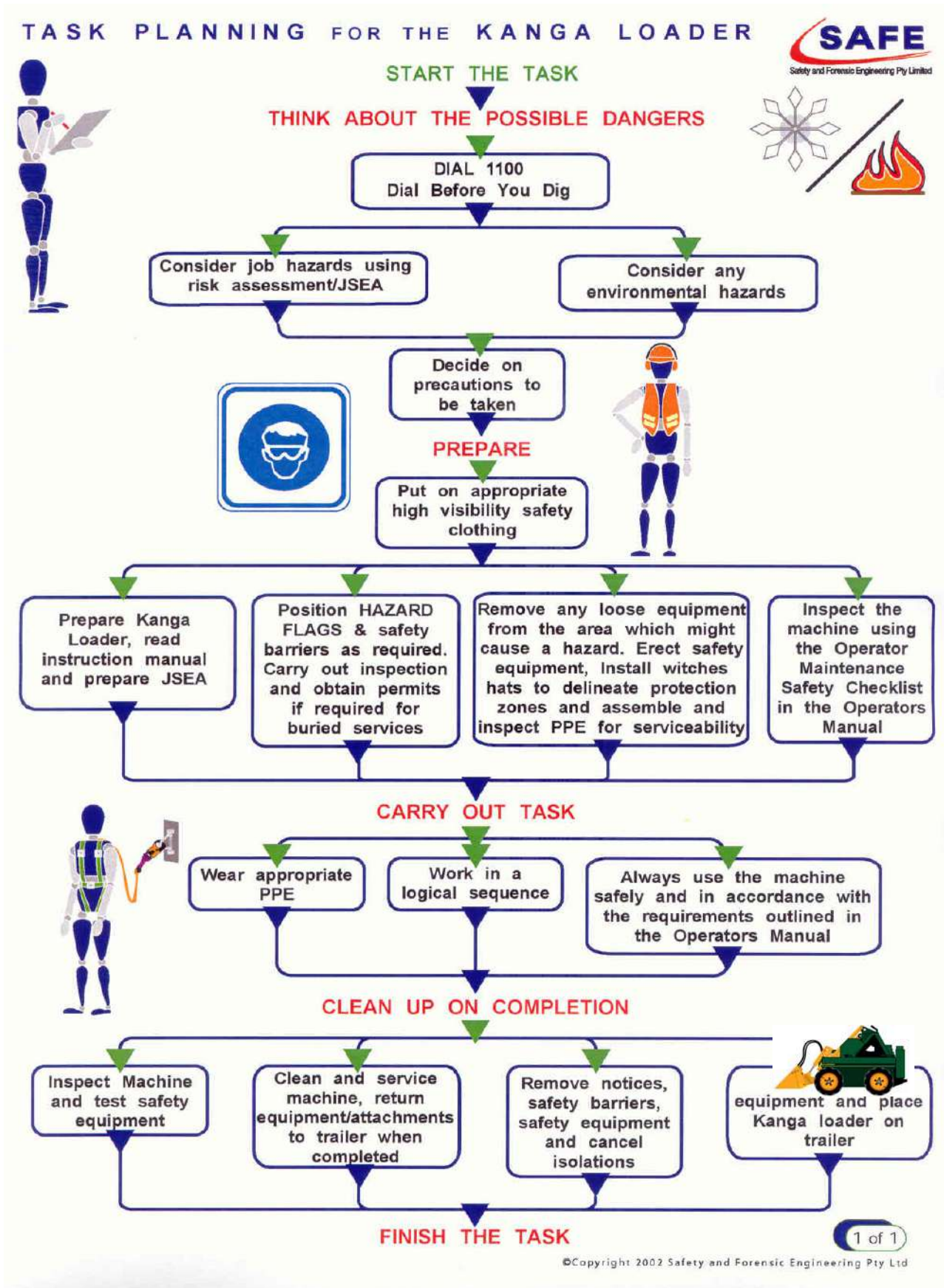



RISK RANKING CHART

How Do I Risk Assess A Hazard?

Using the Kanga Risk Assessment tools:

1. Determine the **likelihood** of the hazard occurring e.g. for example we have determined - **Remote**
2. Determine the **severity** of the consequence e.g. for this example we have determined - **Significant**
3. The resultant score (**X**) is (**5**) which is a "**Low**" risk - we now need to refer to the **Risk Ranking Matrix** for what **action** is required

Note: The higher the score the higher the risk

 RISK RANKING CHART		LIKELIHOOD TO OCCUR				
		P R O B A B L E	O C C A S I O N A L	P O S S I B L E	R E M O T E	V E R Y U N L I K E L Y
CONSEQUENCES						
Severity	Personal injury					
Extreme	Fatality	25	24	22	19	15
Severe	Permanent injury or health issue (e.g. loss of limb)	23	21	18	14	10
Serious	Lose time from work or major treatment by doctor/hospital	20	17	13	9	6
Significant	Minor treatment injury by doctor.	16	12	8	5	3
Minor	Near miss of minor potential consequence or first aid injury	11	7	4	2	1

Risk Ranking Matrix	Action Required
High Risk (20—25)	Implement immediate risk control action measures e.g. cease activity, make job/area safe, seek advice and guidance from qualified persons
Medium Risk (7-19)	Plan and implement risk control action measures - seek advice from Kanga if in doubt about any aspect of the hazard / risk
Low Risk (1-6)	No immediate action, assess overall risk in line with available resources - contact Kanga if in doubt about any aspect of the hazard / risk

JOB SAFETY CHECK

JOB SAFETY CHECK



ASSESS THE RISKS

To keep Safety on **T R A C K**,
before every job **STOP** and:

- T**hink though the Task
- R**ecognise the Hazards
- A**ssess the Risks
- C**ontrol the Hazards
- K**eep Safety First in all Tasks

OUR TARGET IS ZERO INJURIES

SAFE
Safety and Forensic Engineering Pty Limited

www.safegroup.com.au



SAFETY - Rules for Attachments

Only Jaden-Kanga designed and approved attachments are to be used on this machine.

No other attachment is to be used on this machine unless the design and use of the attachment has been assessed and authorised by Jaden-Kanga; and has been supported by a compliant Risk Assessment, which has been verified and validated by Safety and Forensic Engineering Pty Limited.

The following safety requirements should be read in conjunction with the Safety Rules provided for the base model, i.e., Kanga Loader, Kanga Kid, and the corresponding Operating Instructions accordingly. All tasks and risks associated with the activity are identified using the Job Safety and Environmental Analysis (JSEA) or Risk Assessment (RA) and ALL risk controls are to be identified and implemented before the work commences.

LOG SPLITTER SAFETY RULES



LOG SPLITTER

Always...

- Establish and maintain a minimum 4 meter (12 foot) exclusion zone around the local working area and ensure no person other than the operator, enters this zone whilst the machine's engine is running.
- Use leather gloves to protect hands from wood splinters.
- Clear split logs away from the base of the machine, to ensure they do not interfere with the operation of the log splitter. When clearing away the split logs, ensure that the machine is shut down and the pressure released from the hydraulic controls.
- Wear eye protection.

Never...

- Place any article or body part under the log splitter at any time.
- Place any attachment, article or body part in the zone of travel of the log splitter.

FORK LIFT TYNES SAFETY RULES



FORK LIFT TYNES

Always...

- Establish and maintain a minimum 4 meter (12 foot) exclusion zone around the local working area and ensure no person other than the operator, enters this zone whilst the machine's engine is running.
- Keep the general working area clear of bystanders and other workers. Loader operations typically rely on rapid movement and direction changes. It is important, therefore, that the whole operation area is kept clear of other personnel and operators maintain vigilance about their immediate surroundings.

Never...

- Place any article or body part under the tynes at any time.
- Carry passengers, either on the machine or on the tynes of the forklift.
- Overload the machine or tynes.
- Travel with the tynes raised, especially when carrying loads.

ANGLED BACK-FILL BLADE SAFETY RULES



BACK FILL BLADE

Always...

- Establish and maintain a minimum 4 meter (12 foot) exclusion zone around the local working area and ensure no person other than the operator, enters this zone whilst the machine's engine is running.
- Keep the general working area clear of bystanders and other workers. Loader operations typically rely on rapid movement and direction changes. It is important, therefore, that the whole operational area is kept clear of other personnel and operators maintain vigilance about their immediate surroundings.

Never...

- Place any article or body part under or near the angled back-fill blade at any time.

4 IN 1 BUCKET SAFETY RULES



Always...

- Establish and maintain a minimum 4 meter (12 foot) exclusion zone around the local working area and ensure no person other than the operator, enters this zone whilst the machine's engine is running.
- Keep the general working area clear of bystanders and other workers. Loader operations typically rely on rapid movement and direction changes. It is important, therefore, that the whole operation area is kept clear of other personnel and operators maintain vigilance about their immediate surroundings.
- Check with Local Authorities and land owners about the presence of underground services within the prospective working area prior to commencement of work. (Dial **1100** to establish any existing underground services before work commences.)
- Ensure excavations are located a minimum of 2 meters away from any underground service.

Never...

- Place any article or body part between the jaws of an open bucket, or under the bucket at any time.

TERMINATOR STUMP GRINDER SAFETY RULES



Always...

- Establish and maintain a minimum 12 meter (40 foot) exclusion zone around the local working area and ensure no person other than the operator, enters this zone whilst the Loader engine and/or Stump Grinder is/are running.
- Keep the general working area clear of bystanders and other workers. Loader operations typically rely on rapid movement and direction changes. It is important, therefore, that the whole operation area is kept clear of other personnel and operators maintain vigilance about their immediate surroundings.
- Check with Local Authorities and land owners about the presence of underground services within the prospective working area prior to commencement of work. (Dial **1100** to establish any existing underground services before work commences.)
- Install effective perimeter hoarding/barricades 6ft high around the exclusion zone.
- Wear respiratory and eye protection.

Never...

- Place any article or body part under, or in close proximity to, the Stump Grinder at any time.
- Touch the exhaust, engine parts, hydraulic pipes and fittings, guards or Stump Grinder Wheel soon after use.

TRENCHER SAFETY RULES



TRENCHER

Always...

- Establish and maintain a minimum 4 meter (12 foot) exclusion zone around the local working area and ensure no person other than the operator, enters this zone whilst the machine's engine is running.
- Check with Local Authorities and land owners about the presence of underground services within the prospective working area prior to commencement of work. (Dial **1100** to establish any existing underground services before work commences.)
- Ensure trenches are located a minimum of 2 meters away from any underground service.

Never...

- Place any article or body part under the trencher at any time.

POST HOLE AUGER & TREE PLANTER AUGER SAFETY RULES



POST HOLE AUGER

Always...

- Establish and maintain a minimum 4 meter (12 foot) exclusion zone around the local working area and ensure no person other than the operator, enters this zone whilst the machine's engine is running.
- Check with Local Authorities and land owners about the presence of underground services within the prospective working area prior to commencement of work. (Dial **1100** to establish any existing underground services before work commences.)
- Ensure excavations are located a minimum of 2 meters away from any underground service.

Never...

- Place any article or body part under the auger at any time.

ROTARY HOE (TILLER) SAFETY RULES



ROTOR TILLER

Always...

- Establish and maintain a minimum 4 meter (12 foot) exclusion zone around the local working area and ensure no person other than the operator, enters this zone whilst the machine's engine is running.

Never...

- Place any article or body part near or under the Rotary Hoe at any time.
- Carry out maintenance of any type whilst the Rotary Hoe is attached to the Loader or any other power source.

BUCKET BROOM SAFETY RULES



BUCKET BROOM

Always...

- Establish and maintain a minimum 4 meter (12 foot) exclusion zone around the local working area and ensure no person other than the operator, enters this zone whilst the machine's engine is running.
- Keep the general working area clear of bystanders and other workers. Loader operations typically rely on rapid movement and direction changes. It is important, therefore, that the whole operation area is kept clear of other personnel and operators maintain vigilance about their immediate surroundings.
- Wear respiratory and eye protection whilst using the Bucket Broom.

Never...

- Place any body part under the bucket broom at any time.

operating instructions

OPERATING INSTRUCTIONS

BEFORE STARTING

Check the fuel level and fill up if necessary. Ensure that the fuel is the correct type, free from impurities or water. Check that both the crankcase oil and hydraulic oil levels are within operating limits.



CAUTION: Check that all control levers below are in the neutral centre position.

NOTE: The Auxiliary Power Lever (1) does not automatically return to the “Engine Start” position from the “Work” position whilst the operator is standing on the machine. If this lever is not in neutral, the engine will attempt to start under full load. This will place strain on the starter motor potentially flattening the battery.

STARTING

Refer to the engine manual for correct throttle (9) starting positions in warm and cold conditions. Turn starter key switch to start engine.

In the case of diesel powered engines, hold the key in the “GL” position until the Glow Plug indicator light goes off before engaging the starter motor.



CAUTION: Do not move any of the control levers unless standing with both feet on the driving platform and holding the grip handles, ensuring non-operating personnel are clear of the Loader.

CONTROLS

On the top face of the KANGA Loader are six spring centred levers which control the basic functions. The table below indicates the levers with their corresponding functions:

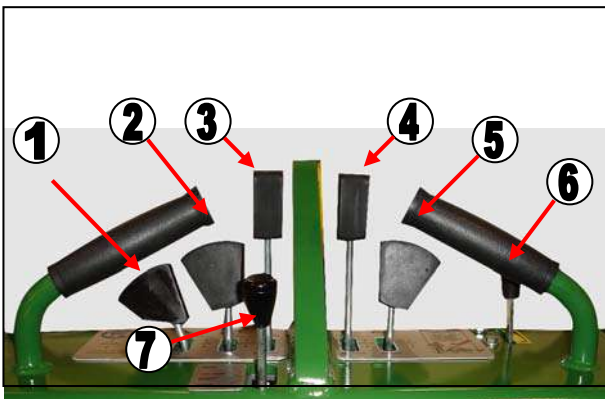

Lever	Push	Pull
1	4in1 Open	4in1 Close
2	Lower Arm	Raise Arm
3	Left Drive Forward	Left Drive Backward
4	Right Drive Forward	Right Drive Backward
5	Tilt Forwards	Tilt Backwards
6	Throttle Increase	Throttle Decrease
7	Aux Reverse	Aux Forward

PARKING AND SHUTDOWN

When parking the Kanga always select level ground and lower any bucket or attachment fitted fully to the ground. To shut down, reduce the engine speed to idle and turn the key to the off position. Remove the key to prevent unauthorized use.



CAUTION: Do not park or leave the machine on steep slopes.

- When loading/unloading the Kanga from the trailer, it is important that the trailer remains attached to the towing vehicle on a firm even surface.
- Do not unload a trailer on a slope.
- Ensure bystanders are sufficiently clear.
- All loading/unloading to be carried out using a ramp must be done at a slow speed, with due care for personal safety and damage to equipment. Practice the manoeuvres first on flat ground if necessary.
- Use appropriately rated slings and shackles, and attach to the lifting point on the top of the machine when lifting the machine.
- Always use the tie down points on each side of the machine to secure the Loader when transporting.
- Always use witches hats, signage and traffic signals to control the unloading/loading zone, particularly when in close proximity to operational roads.



CAUTION: First time users to use slow 1/3 throttle to practice safe operation before commencing work. The recommended normal operating speed of the machine is 2/3 to 3/4 throttle.

MANOEUVERING

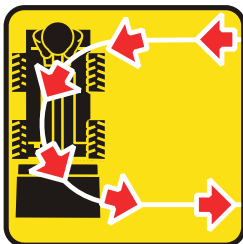
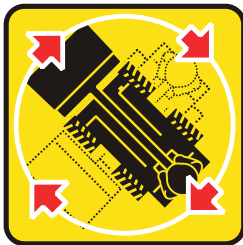

MANOEUVRING

The forward and reverse levers should be thought of as softly operated clutches for engaging and disengaging the wheels. Use slow even movements of the control levers for smooth operation of the Loader. Practice slow starts and gentle stops in an open, safe area.

Manoeuvring is made possible by individual controls for the hydraulic motors on each side of the machine. A turn may be achieved by varying the amount and/or direction of power supplied to each side of the machine. The machine is capable of turning in its own length by applying equal forward and reverse power to opposite sides of the machine.

While moving forward, a gentle turn to the left for instance, can be made by slightly increasing the power to the right hand side or by reducing the power to the left hand side of the machine. This mode of steering allows the type of turn to be chosen to suit the situation.



3. ENSURE BOTH (2) ATTACHMENT LOCK PINS ARE FULLY ENGAGED



CAUTION: Always ensure that the attachment Locking Pins are fully engaged at all times.



DIGGING

SAFE AND EFFICIENT USE OF BUCKETS

When lifting soil from a heap or pile, always have the bucket level. To achieve this, push the Loader arm downwards and use the tilt ram to bring the bucket level with the ground.

Towards the end of the run when the bucket is nearly full, gently tilt the bucket (rotate the bucket) towards the Loader. This decreases the lifting resistance when the arms are raised and promotes an efficient tear out.

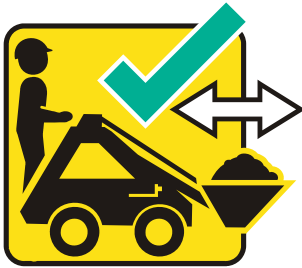

5. TRANSPORT MATERIAL WITH BUCKET DOWN AND LEVEL

When transporting material in the bucket on slopes or rough ground, always keep the bucket close to ground level. This lowers the centre of gravity of the Loader and maximises stability.

The material may then be dumped into a trailer or utility truck for removal or repositioning on the site.



11. DO NOT TRAVEL WITH ARMS RAISED



CAUTION: Do not step off the operator platform with the load raised or the machine moving.



CAUTION: Always ensure that the attachment Locking Pins are fully engaged at all times.



1. READ OPERATORS MANUAL PRIOR TO USE



6. ALWAYS REVERSE DOWN SLOPES WITH LOAD



13. NO PERSONNEL IN BUCKET OR ATTACHMENTS



12. AVOID TRAVELLING ACROSS SLOPES



10. DO NOT PLACE FEET UNDER STANDING PLATFORM



14. PAY ATTENTION



CAUTION: The kanga Loader is not fitted with a “seat belt”. The standing position is a safety feature which allows a quick exit from the machine in case of an emergency. Do not add a restriction system to the machine which will limit your ability to safely exit from the Kanga Loader.



CAUTION: Always exercise care when operating on slopes. The Kanga Loader is approximately 1 meter (39”) wide, which is a great benefit for providing access to confined spaces, however, the machine may become unstable if operating across a slope. If it is impossible to avoid crossing a slope keep the load close to the ground and travel at reduced speed.

The maximum safe angle of slope is 20°. This angle is a recommendation only. The actual safe slope angle will depend on site conditions, operator experience and activity. .

SERIAL NUMBER REGISTRATION

MAIN COMPONENT SERIAL NUMBERS

KANGA Serial No.:

Engine Type:

Serial No.:

Wheel Motors: FRONT RIGHT:

REAR RIGHT:

FRONT LEFT:

REAR LEFT:

Lift Ram:

Tilt Ram:

Hydraulic Pump:

Control Valve:

Date Purchased:

maintenance

DAILY OPERATOR MAINTENANCE

INSPECTION AND CHECKS



2. DAILY INSPECTION

Before each day's operation of the KANGA Loader, the **operator MUST** perform the inspection and checks as outlined below.

The purpose of the operator's inspection is to keep the equipment in a safe working condition and to detect any signs of malfunctioning during normal operations between scheduled maintenance checks.

While it may not be the operator's responsibility to perform mechanical maintenance, they should be thoroughly familiar with the unit, as this involves their own safety.

Many costly maintenance jobs can be prevented through observance of the following operator maintenance inspections and checks by KANGA Loader operators.



CAUTION: DO NOT operate a Kanga Loader that is known to be damaged or malfunctioning. Remove the key from the ignition and Tag Out the machine using an Out of Service tag and contact your Service Agent.

Defective components and/or equipment malfunctions can jeopardise the safety of the operator and other personnel and can cause extensive damage to the unit. Remember, a poorly maintained unit could become a great operational hazard.

LOADER ARM MAINTENANCE



BOOM MAINTENANCE

Always...

- Secure the Arm using the supplied Locking Pins when carrying out maintenance activities, particularly when working with the Arm in the raised position.
- Keep a fire extinguisher on hand during maintenance operations.
- Ensure the working area is kept clean and free of oil, grease and debris.
- Designate the effective maintenance work area using witches hats.

Never...

- Rely solely on the machine hydraulics to keep the Arm elevated whilst carrying out maintenance. Locking Pins should always be used to physically hold the boom in the raised position.
- Raise or lower the boom with the Locking Pins in place.



Locking Pins are kept to either side of the controls.



Locking Pins in position.



OPERATOR MAINTENANCE - SAFETY CHECKS

DAILY CHECKS				
Element	Yes	No	Comments	
LOADER				
Tyres & Wheels	Good condition/adequate tread			
	Adequate pressure			
	Wheel Nuts secure			
Guarding	Good condition			
	Secure			
Hydraulics	Good condition of hoses (check for leaks)			
	Good condition of casings (check for leaks)			
	Good condition of rams (check for leaks)			
	Adequate hydraulic oil level			
Controls	Correct operation			
	Responsiveness			
Structure	Adequate weld condition			
	Free of cracks/damage			
	Linkage Pins greased			
Bolts and Fasteners	Check pivot pins for wear/damage			
	Tight			
	None missing or damaged			
Battery	Terminals tight			
	Free of corrosion			
	Good condition (check indicator)			
Safety Decals	Legible			
	All in place			
Engine	Adequate crankcase oil level			
Fuel	No leakage			
	Adequate fuel level			
Operating Manual	Present with machine			
ATTACHMENTS				
Guarding	Good condition			
	Secure			
Hydraulics	Good condition of hoses (Check for leaks)			
	Good condition of casings (Check for leaks)			
	Good condition of rams (Check for leaks)			
Controls	Correct operation			
	Responsiveness			
Structure	Adequate weld condition			
	Free of cracks/damage			
Bolts and Fasteners	Tight			
	None missing			
	Attachment locking pins in place			
Decals	Legible			
	All in place			
Operating Supplement	Present with machine/attachment			



SERVICE CHART

ACTIVITY	HOURS	20	120	220	320	420	520	620	720	820	920	1020	1120	1220	1320	1420
ENGINE OIL (PETROL ENGINE)		R	R	R	R	R	R	R	R	R	R	R	R	R	R	R
ENGINE OIL FILTER (PETROL ENGINE)			R	R	R	R	R	R	R	R	R	R	R	R	R	R
ACTIVITY	HOURS	50	150	250	350	450	550	650	750	850	950	1050	1150	1250	1350	1450
ENGINE OIL (DIESEL ENGINE)		R	R	R	R	R	R	R	R	R	R	R	R	R	R	R
ENGINE OIL FILTER (DIESEL ENGINE)		R		R		R		R		R		R		R		R
ACTIVITY	HOURS	8	16	24	32	40	48	56	64	72	80	88	96	104	112	120
GREASE ALL PINS		X	X	X	X	X	X	X	X	X	X	X	X	X	X	X
AIR FILTER*		X	X	X	X	X	X	X	X	X	X	X	X	X	X	X
ACTIVITY	HOURS	100	200	300	400	500	600	700	800	900	1000	1100	1200	1300	1400	1500
AIR FILTER*			R		R		R		R		R		R		R	
FUEL FILTER (PETROL ENGINE)*		R	R	R	R	R	R	R	R	R	R	R	R	R	R	R
FUEL FILTER (DIESEL ENGINE)*			R		R		R		R		R		R		R	
IDLE SPEED (PETROL ENGINE)			X		X		X		X		X		X		X	
SPARK PLUGS (PETROL ENGINE)		X	R	X	R	X	R	X	R	X	R	X	R	X	R	X
VALVE CLEARANCE (PETROL ENGINE)			X		X		X		X		X		X		X	
VALVE CLEARANCE (DIESEL ENGINE)									X							
HYDRAULICS		X	X	X	X	X	X	X	X	X	X	X	X	X	X	X
HYDRAULIC FLUID											R					
HYDRAULIC FILTER RETURN			R		R		R		R		R		R		R	
HYDRAULIC FILTER PRESSURE						R					R					
TYRES		X	X	X	X	X	X	X	X	X	X	X	X	X	X	X
VISUAL CHECK		X	X	X	X	X	X	X	X	X	X	X	X	X	X	X
PIVOT PINS											R					
SERVICE STAMP																
DATE SERVICED																

Note.

The warranty on the equipment is subject to the periodic maintenance being carried out at the intervals specified. If a service provider other than Kanga Loaders is used, maintenance records from the trade qualified provider may be required to support any claim.

Only genuine Kanga spare parts should be used during servicing.

* Replace sooner if used in dusty environment.

LEGEND:
 X = SERVICE
 R = REPLACE

SERVICE TASKS

The following service work should only be carried out by a qualified Service Technician at intervals indicated on the Service Chart.

The operating hours are displayed by the Hour Meter on the Instrument Panel. The display will flash for 2 hours when a service is due. The flashing will cease after a two hour operating period has passed. Also displayed on the Instrument Panel on all Loaders are a Fuel Gauge, a Charge Warning Light and an Oil Warning Light. A Water Temperature Warning Light and Glow Plug Light are also included on the Instrument Panel for the diesel Loaders only.

Petrol Instrument Panel



Diesel Instrument Panel



SERVICE TASKS - Engine

Engine Oil (Petrol Engine)

Change the engine oil after the first 20 hours of operation and thereafter, after every 100 hours. Generally engine oil type SAE 10W-30 is recommended. See Engine Manual for details.

Engine Oil (Diesel Engine)

Change the engine oil after the first 50 hours of operation and thereafter after every 100 hours. The following engine oil type is recommended.

Ambient Temperature	Oil Type
Above 25°C (77°F)	SAE 30 or SAE10W-30/SAE10W-40
0°C to 25°C (32°F to 77°F)	SAE 20 or SAE10W-30/SAE10W-40
Below 0°C (32°F)	SAE 10 or SAE10W-30/SAE10W-40

Engine Oil Filter (Petrol Engine)

Replace the oil filter after every 100 hours of operation. See Engine Manual for details.

Engine Oil Filter (Diesel Engine)

Replace the oil filter after every 200 hours of operation. See Engine Manual for details.

Air Filter (Petrol and Diesel Engine)

Service and clean the air filter after every 8 hours of operation. Replace the air filter after every 200 hours of operation, or sooner if operating in a dusty environment.

Fuel Filter (Petrol Engine)

Replace the fuel filter after every 100 hours of operation, or sooner if operating in a dusty environment.

Fuel Filter (Diesel Engine)

Clean the fuel filter pot (fitted to early models prior to April 2008) after every 100 hours of operation. Replace the fuel filter after every 200 hours of operation, or sooner if operating in a dusty environment. Check the fuel pipes after every 50 hours of operation and replace if worn or leaking.



Photo showing early model fuel filter up to **March 2008**.



Photo showing current model fuel filter and mounting bracket from **Mid 2008**.

Diesel Loaders built **AFTER AUGUST 2008** are fitted with Kubota fuel filter Kit # 262 Part # **L115965-10A-1**. Models produced after this date will only require the filter Part # **L120400A** to suit Kubota Kit # 262 when servicing the filter.

Early models will require a retro fit kit **PART # L115965-10A-1 - FUEL FILTER UPGRADE RETRO KIT 25HP 3CYL**, if there is damage to the filter head or housing which are no longer available.



Idle Speed (Petrol Engine)

Check engine idle speed after every 200 hours of operation, and adjust if out of specification. See Engine Manual for details.

Spark Plugs (Petrol Engine)

Check and adjust after every 100 operating hours. Replace after every 200 hours.

Valve Clearances (Petrol Engine)

Check and adjust engine valve clearances after every 200 hours of operation. See Engine Manual for details.

Valve Clearance (Diesel Engine)

Check and adjust engine valve clearances after every 800 hours of operation. See Engine Manual for details.

SERVICE TASKS - Hydraulics

Hydraulics

Perform the following work after every 100 operating hours:

Check hydraulic fluid level (**with arms down and oil cold**) top up with Hydraulic Oil ISO 68

NOTE: A significant drop in fluid levels will indicate leakage. The appropriate cold fluid level is indicated on the site gauge.

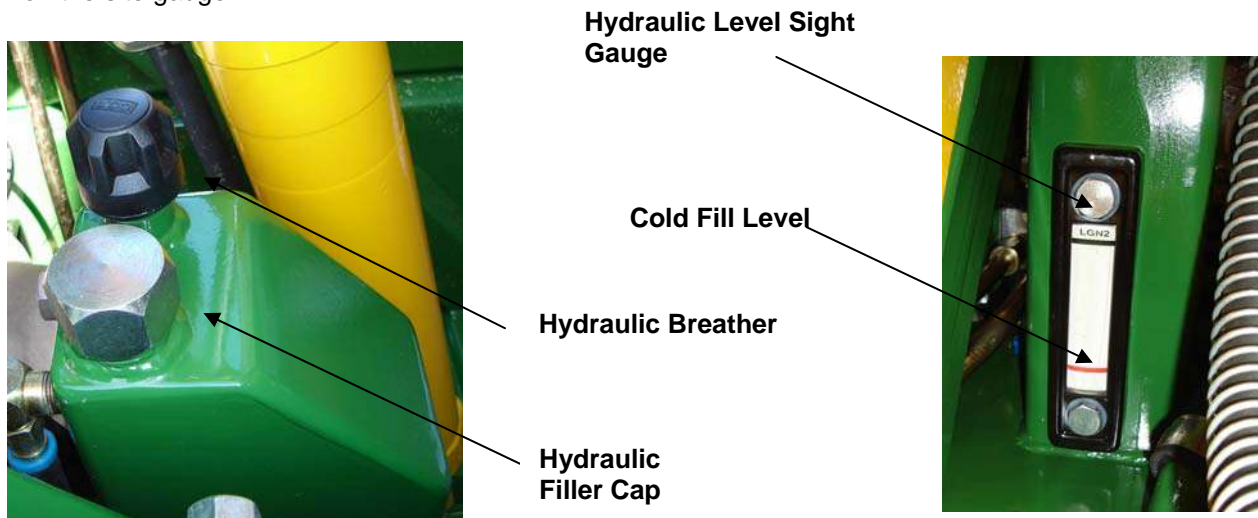

Inspect all hydraulic hoses, tubes, fittings, valves and rams for leaks and damage. Tighten loose fittings and replace damaged components.

Check all three pressure settings (see procedure on following page) and adjust if necessary.

Hydraulic Filters

Replace the return line filter cartridge after every 200 operating hours. Replace the pressure line filter cartridge after every 500 operating hours.

Return Filter Element Part No: L116442

Pressure Filter Element Part No: L116420
(Illustration shows housing)



Hydraulic Pressure Settings

The hydraulic system has three pressure settings which have to be set as follows:

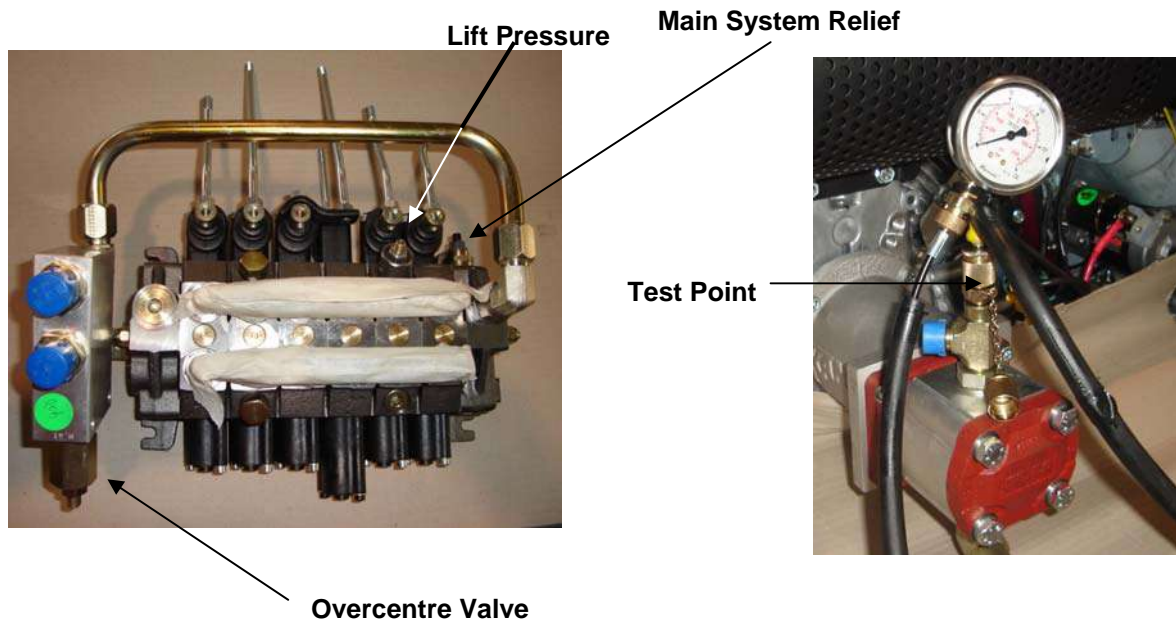

Before any testing is carried out run the engine and hydraulic system to warm the hydraulic oil. The oil cooler fan will engage at between 60 and 65 °C (145 °F).

All pressure settings are performed with the **engine running at full speed (3,600 rpm)**.

OVER CENTRE VALVE

Connect an accurate pressure gauge with a range **0-300 bar (0-4,300 PSI)** to the **Test Point**.

The pressure should be set at: **31-34 bar (450-500 PSI) for the 11.3cc Pump**
41 bar (600 PSI) for the 12.5cc Pump

NOTE: If adjustment is required slacken off the lock nut and using a 5mm hex key wind in the screw to increase the pressure or back off the screw to reduce the pressure. Retighten the lock nut when adjustments are complete.

MAIN SYSTEM RELIEF PRESSURE

Connect an accurate pressure gauge with a range **0-300 bar (0-4,300 PSI)** to the **Test Point**.

Check the pressure while pulling the **tilt control lever** at the end of the ram's stroke.

The pressure should be set at: **203 bar (2,950 PSI) for the DA520, GA524, GA624 & GA724**
221 bar (3,200 PSI) for the DA625 & DA725

NOTE: If adjustment is necessary slacken off the lock nut and wind in the screw to increase the pressure or back off the screw to reduce the pressure. Retighten the lock nut when adjustments are complete.

LIFT PRESSURE

Connect an accurate pressure gauge with a range **0-300 bar (0-4,300 PSI)** to the **Test Point**.

Check the pressure while pulling the **arm control lever** at the end of the ram's stroke (boom fully raised).

The pressure should be set at: **165 bar (2,400 PSI) for all A Series Loaders.**

NOTE: If adjustment is necessary unscrew and remove the cap lock nut and wind in the screw using a screw driver to increase the pressure or back off the screw to reduce the pressure. Refit and tighten the lock nut when adjustments are complete.

Hydraulic Fluid

Replace the hydraulic oil after every 1,000 operating hours.

(Hydraulic Oil ISO 68)

HYDRAULIC OIL DRAIN PLUG
(Situated between the wheel motors on the right hand side of Loader)

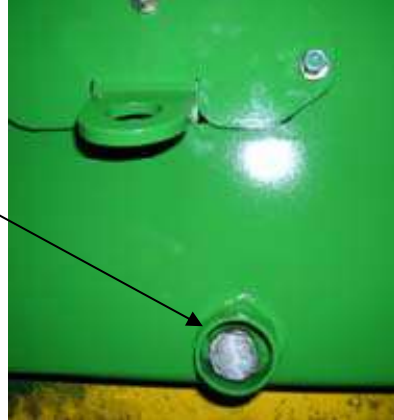

SERVICE TASKS - Grease Nipple

Grease

Grease*, all eleven (11) **linkage pins** after every 8 operating hours. (Grease type Castrol APX T or equivalent) Inspect for wear after every 100 operating hours.

* The frequency for regreasing depends on the workload and the severity of the working conditions. Regreasing during the day of operation may be necessary (see 'Daily Checks').

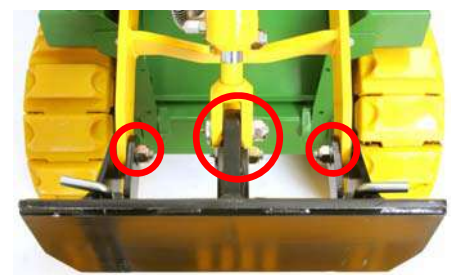

Grease Nipples





SERVICE TASKS - Tyre Pressure

Tyres

Visually check tyres on a daily basis and check tyre pressure every 50 operating hours, and check for wear and damage to tyres and tracks.

Tyre pressures:

KANGA Loader Tyre Pressures				
Tyre	Size	Recommended Pressure		Gross Weight Kgs (Water Filled)
		kPa	PSI	
Lug 19"	19 x 8 x 10	260	38	25
Turf 19"	205/65 x 10	206	30	25
Sand 20"	20 x 8 x 10	150	22	25
Sand 20" wide	20 x 10 x 10	150	22	25
Lug 23"	23 x 8.5 x 12	260	38	40
Turf 23"	23 x 8.5 x 12	150	22	40
7 SeriesTrack	145 x 10	380 - 520*	55 - 75*	N/A

* Minimum 55psi (380kPa) and maximum 75psi (520kPa). Tyre pressure will have to be increased over time to allow for wear in the track system. When traction between the drive wheel and track is lost, increase tyre pressure in 5psi stages to compensate for wear. If traction is lost when the tyre pressure is set at 75psi, track chain links will need to be removed to tighten the tracks. Refer to the Chain Link Removal section. Once links are removed tyre pressure must be decreased in accordance with instructions.

SERVICE TASKS - Battery

Battery

The battery provided with the Loader is maintenance free. An indicator at the top of the battery displays it's condition according to a displayed colour. Ensure that the terminals are tight and that covers and battery leads are not damaged.

SERVICE TASKS - Visual

Visual Check

Check all over machine for loose bolts, cracks and dents after every 100 operating hours. Tighten loose bolts, and replace if worn or damaged.

SERVICE TASKS - Pivot Pins

Bottom Pivot Pins

Before every use, visually inspect all pivot pins for any signs of wear and damage or possible failure.

Thoroughly inspect all pivot pins and bushes for wear and damage at an interval of 200 operating hours.

Replace the bushes as required and the four pivot pins on the attachment plate after every 1,000 hours of operation.

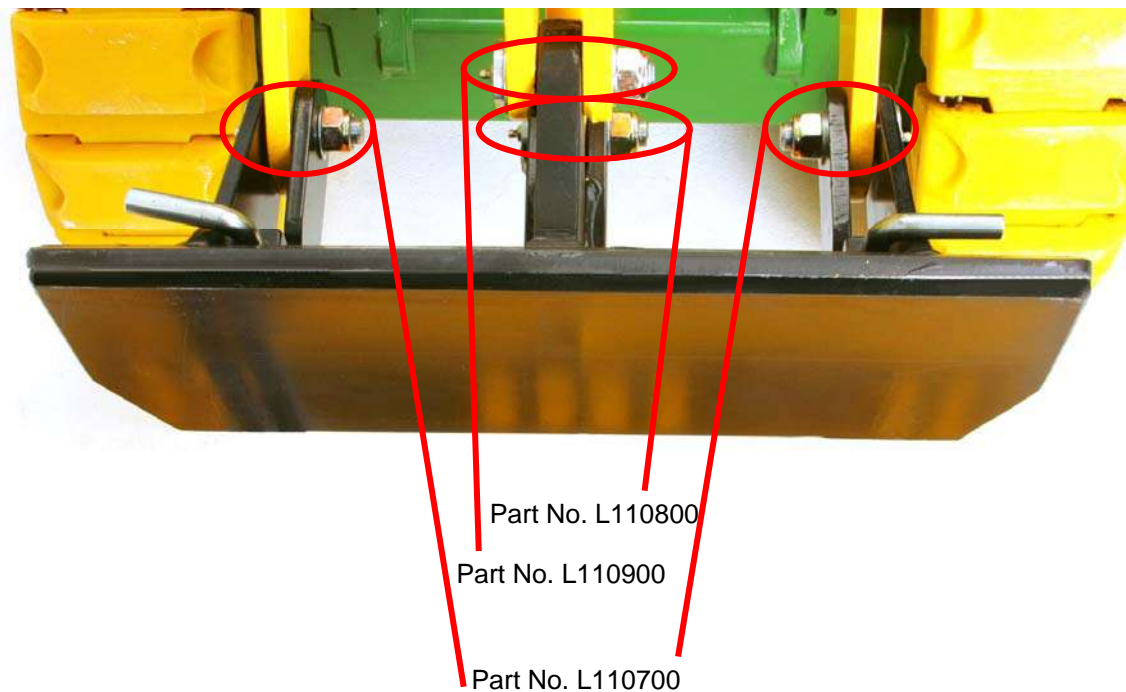



TROUBLESHOOTING

This section contains trouble-shooting information to be used for locating and correcting problems which may develop with your KANGA Loader.

Troubleshooting and maintenance information relating to the engine are contained in the Engine Manual.

Arms

TROUBLE	PROBABLE CAUSE	REMEDY
Arm will not rise.	Load capacity exceeded.	Reduce load. Load should not exceed the specified SWL displayed on the machine.
	Hydraulic system oil level low.	Check oil and replenish as necessary. Oil level should not change. Leaks may be present.
	Damaged or blocked hydraulic line.	Remove line and remove any obstructions or replace line as necessary.
	Malfunctioning hydraulic pump.	Replace Hydraulic Pump as necessary.
	Worn Control Valve spool.	Check pressure delivery from Control Valve. Contact Service Agent.
	Lift Control Valve relief set too low, allowing oil to return to reservoir.	Adjust relief valve to proper setting. Contact service Agent.
	Excessive oil leak past lift cylinder piston seal.	Repair or replace cylinder as necessary.
Arm will not lower.	Hydraulic oil system low.	Check oil and replenish as necessary. Oil level should not change. Leaks may be present.
	Damaged or blocked hydraulic line.	Remove line and remove any obstructions or replace line as necessary.
	Malfunctioning pump	Replace Hydraulic Pump as necessary.
	Worn Control Valve spool.	Check pressure delivery from Control Valve. Contact Service Agent.
	Control rod or lever broken or disconnected.	Repair or replace control rod or lever.



Arm - (continued)

TROUBLE	PROBABLE CAUSE	REMEDY
Arm will not rise, or rises slowly.	Lift Control Valve relief set too low allowing oil to return to reservoir.	Adjust relief valve to proper setting. Contact Service Agent.
	Worn Control Valve spool.	Check pressure delivery from Control Valve. Contact Service Agent.
	Excessive oil leak past lift cylinder piston seal.	Repair or replace cylinder as necessary.
	Control rod or lever broken or disconnected.	Repair or replace control rod or lever.
	Hydraulic lines incorrectly connected at Control Valve.	Correctly connect line at Control Valve.
Arm rises and lowers erratically.	Lift Control Valve relief set too low, allowing oil to return to reservoir.	Adjust relief valve to proper setting.
	Hydraulic system oil low.	Check oil and replenish as necessary. Oil level should not change. Leaks may be present.
	Damaged or blocked line.	Remove line and remove any obstructions or replace line as necessary.
	Malfunctioning pump.	Repair or replace hydraulic pump as necessary.
	Worn Control Valve spool.	Check pressure delivery from Control Valve. Repair or replace valve as required.
Arm Lowers with control lever in neutral.	Excessive oil leak past lift cylinder piston seal.	Repair or replace cylinder as necessary.
	Arm pivot pin seized or otherwise damaged.	Replace pivot pin and bushing as necessary. Grease thoroughly.
	Worn Control Valve spool.	Repair or replace valve as required.
	Lift ram piston seal leaking.	Replace seals.



Drive System

TROUBLE	PROBABLE CAUSE	REMEDY
Machine will not drive forwards or backwards.	Hydraulic system oil low.	Check oil and replenish as necessary. Oil level should not change. Leaks may be present.
	Worn Control Valve spool.	Check pressure delivery from Control Valve. Repair or replace valve as required.
	Damaged or blocked line.	Remove line and remove any obstructions or replace line as necessary.
	Control rod or lever broken or disconnected.	Repair or replace control rod or lever.
	Hydraulic lines incorrectly connected at Control Valve.	Correctly connect line at Control Valve.
Machine drive speed is erratic.	Malfunctioning pump.	Repair or replace pump.
	Hydraulic system oil low.	Check oil and replenish as necessary. Oil level should not change. Leaks may be present.
	Damaged or blocked line.	Remove line and remove any obstructions or replace line as necessary.
	Binding drive motor(s).	Repair or replace motor(s) as necessary.
	Relief valve setting.	Adjust relief valve.

Hydraulic Pump

TROUBLE	PROBABLE CAUSE	REMEDY
Flow from hydraulic pump erratic or non existent	Hydraulic system oil low.	Check oil and replenish as necessary. Oil level should not change. Leaks may be present.
	Damaged or blocked line.	Remove line and remove any obstructions or replace line as necessary.
	Worn or chipped pump gears.	Replace pump gears as necessary.
	Worn or broken drive shaft or coupling.	Inspect drive shaft or coupling. Repair or replace as necessary.
Hydraulic pump noisy	Air in hydraulic system.	Check suction side or hydraulic system for defects and repair as necessary. Ensure no leaks exist in the suction line.
	Hydraulic system oil low.	Check oil and replenish as necessary. Oil level should not change. Leaks may be present.
	Worn or broken drive shaft or coupling.	Inspect drive shaft or coupling. Repair or replace as necessary.
	Worn or chipped pump gears.	Replace pump gears as necessary.



Auxiliary Hydraulic

TROUBLE	PROBABLE CAUSE	REMEDY
Attachment is slow or will not function.	Hydraulic system oil low.	Check oil and replenish as necessary. Oil level should not change. Leaks may be present.
	Damaged or blocked line.	Remove line and remove any obstructions or replace line as necessary.
	Malfunctioning pump.	Replace Hydraulic Pump as necessary.
	Worn Control Valve spool.	Check pressure delivery from Control Valve. Repair or replace valve as required.
	Attachment plate pivot pin seized or otherwise damaged.	Replace pivot pin and bushing as necessary. Grease thoroughly.
	Excessive oil leak past cylinder piston seal or motor rotating group.	Repair or replace cylinder motor as necessary.
	Control rod or lever broken or disconnected.	Repair or replace control rod or lever.

Engine

TROUBLE	PROBABLE CAUSE	REMEDY
Engine will not crank over	Low battery output.	Recharge or replace battery.
	Loose, disconnected or broken battery cables.	Inspect cable(s) and tighten all connections. Repair or replace cables as necessary.
	Faulty Starter.	Repair or replace starter.
	Faulty circuit wiring.	Check wiring continuity.
	Engine flooded (petrol).	Remove spark plug and crank.
Engine cranks but not fires	No fuel in tank.	Refill fuel tank.
	Spark plug fouled (petrol engines).	Check spark plug gap and clean or replace spark plug.
	Dirty fuel filter.	Clean filter.
	Carburettor flood (petrol engines).	Clear carburettor.
	Fuel valve closed.	Open valve.
Engine runs but stalls.	Spark plug fouled (petrol engines).	Check spark plug gap & clean or replace.
	Fuel valve closed.	Open valve.
	Low battery output.	Recharge or replace battery.
	Power take-off engaged.	Shift power take-off lever into neutral.

tracks

TRACKS (Series 7 only) – Safety/Parts



CAUTION: Observe all Safety Rules as outlined in the Operator's Manual.



CAUTION: The series 7 Track Loader is capable of negotiating very steep inclines outside the safe operating limit of the machine. It is possible to tip the Loader backwards when climbing or descending a steep bank and with little load in the bucket.

Do not use this machine on slopes without assessing the risks and fully identifying the required risk control measures by use of a Job Safety and Environment Analysis (JSEA) or Risk Assessment (RA).

Do **NOT** operate on slopes without undertaking a risk assessment and complying with the requirements outlined in the Safe Operation section of the manual.

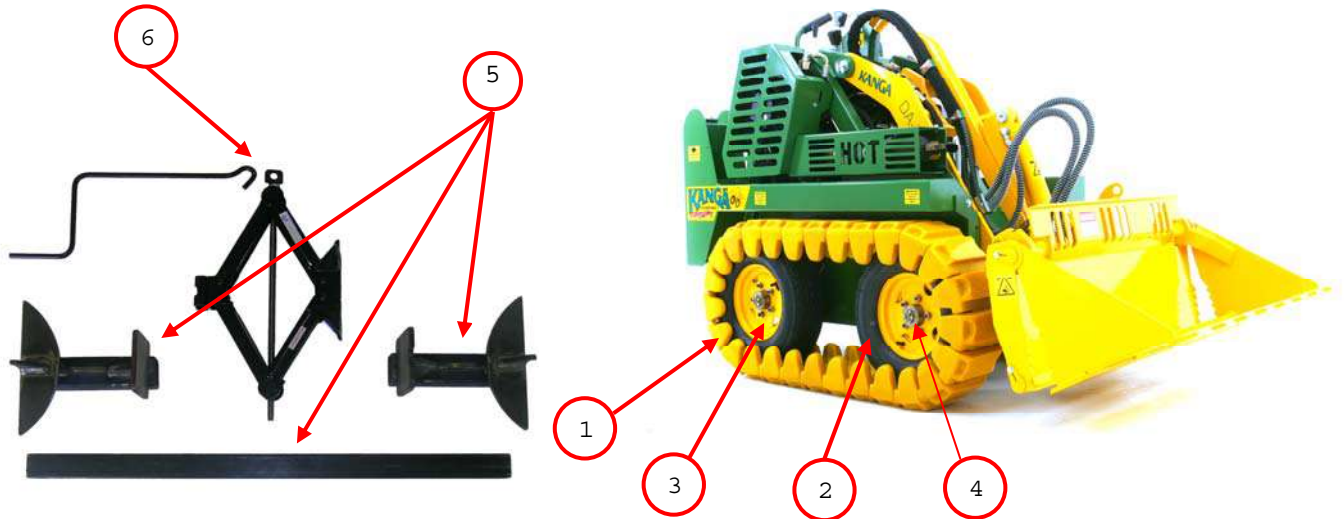

Parts		
No	DESCRIPTION	PART No
1	TRACK ASSEMBLY WITH CHAIN(2 OFF)	OK14313
2	TRACK DRIVE TYRE (4 OFF)	L114301
3	TRACK DRIVE RIM (4 OFF)	L114211
4	HUB	OK12714
5	TRACK TOOL 7 & 8 SERIES, SCISSOR TYPE	OK14315
6	SCISSOR JACK 1 TONNE	L150209-1

TRACKS INSTALLATION

DISASSEMBLY

1. Attach a bucket to the Loader, ensuring the attachment Locking Pins are fully engaged.
2. Position the Loader on level, solid ground for a stable working base.
3. Place suitable wooden blocks or stands under the flat section of the Loader base at the rear of the Loader.
4. Place the bucket flat on the ground.
5. Tilt the bucket forward (as if dumping) and the Loader will lift clear of the ground, supported by the block and the bucket.
6. When tracks are clear of ground at both ends, place another wooden block or a stand under the base at the front of the Loader.
7. Deflate tyres to 25psi.
8. Remove the wheel nuts and use a suitable lever to remove the front wheel from the hub. Repeat for the rear wheel.



STEP 3



STEP 4

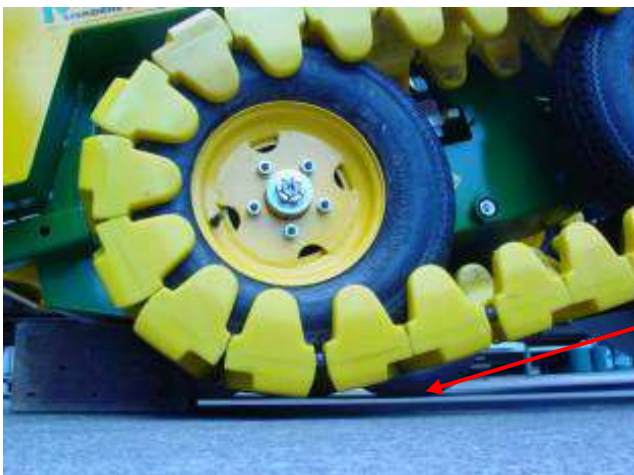

TRACKS
OFF THE
GROUND

INSTALLATION OF TRACKS

1. Set tyre pressure at 25psi.
2. Position the wheels with the valves in the same orientation to assist with aligning the wheels to the studs, ensuring the wheels and tracks are laying flat on the floor.
3. Attach the left and right end segments of the tool to the wheels as illustrated.
4. Slide the guide through both segments.
5. Install the scissor jack, with handle end pointing through the top of the track.
6. Tension the jack to extend the track assembly and stand the track upright.
7. Use two people to lift the tracks onto hub spigot; you may have to adjust the jack to suit.
8. Use an adjustable wrench to rotate the rear hub so the studs will line up with the wheel while depressing forward/ reverse control lever. Do not start the engine.
9. Locate the rear wheel on the hub and studs and install one wheel nut to hold the wheel to the hub.
10. Rotate the front hub with an adjustable wrench to line up the studs to the wheel while depressing forward/ reverse control lever. Do not start engine. To do this, the jack may have to be extended or retracted. If the tracks cannot be extended far enough using the scissor jack, reduce the tyre pressure and extend the scissor jack further.
11. Install all wheel nuts and tighten to 135Nm (100 ft-lb).
12. Adjust tyre pressure to between 55psi and 75psi. Refer to the Tyre Pressure Section for further tyre pressure information.

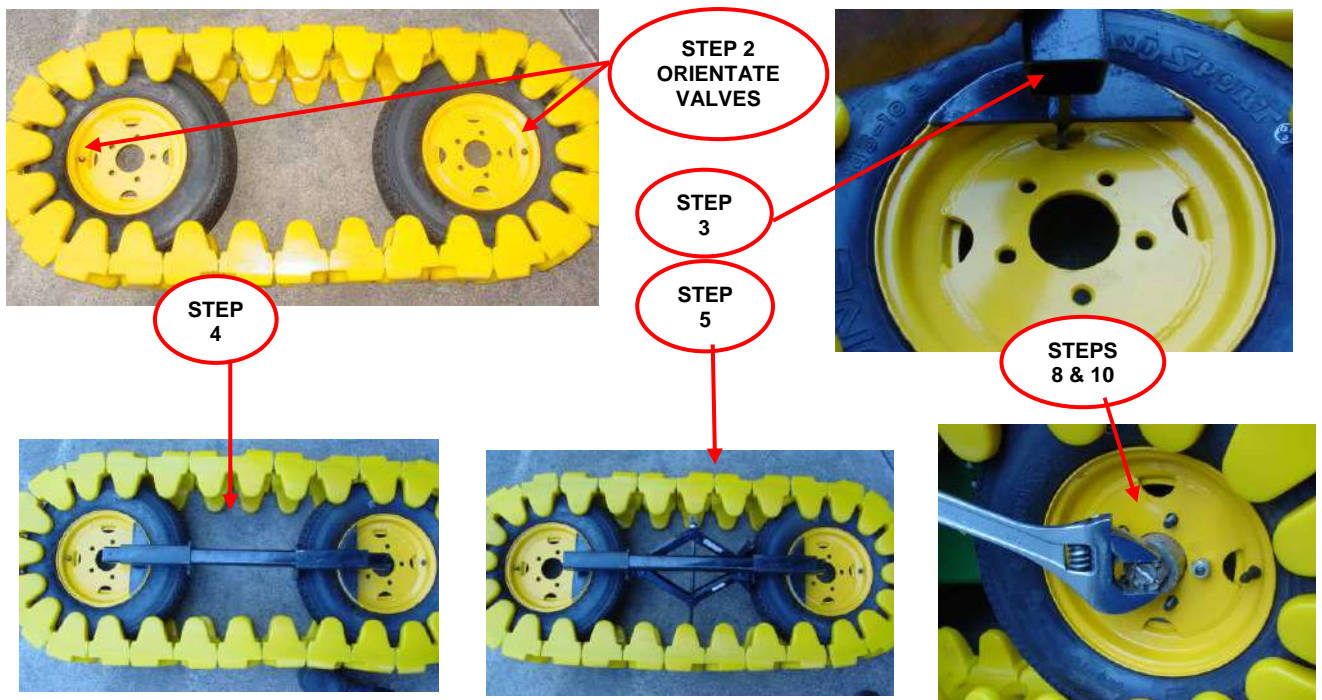

TRACK ORIENTATION OPTION

URO Track Grip Option

There are 2 different configurations that you can have the tracks set to for grip. All Loaders will come set up with option 1.

However if customers would like to change the tracks around to try a different set up they can. We feel that the way that they are supplied is the best all round set up.

Option 2 is best suited for muddy or sandy conditions.

URO Track Roller Train 7 Series Part Number: 0K14313

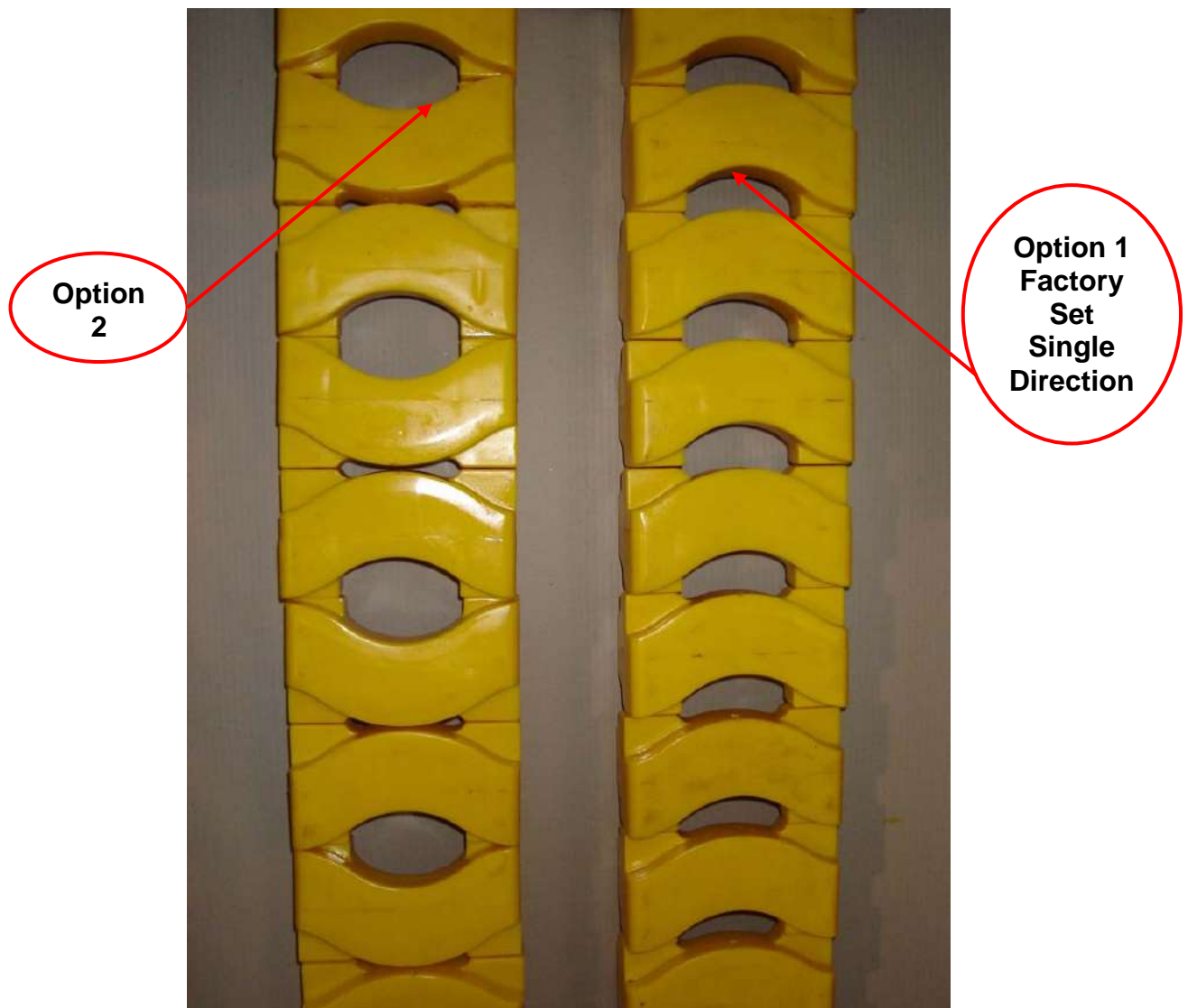

Follow these instructions to change the option, start by removing the tracks from the machine; use the **Track Removal Instructions** to perform this operation.

1. Once the track is removed, lay the track on its side and use a flat blade screw driver or suitable lever to move the chain through the track to the joining link. If you have trouble doing this you can purchase a spare joiner for repair or adjustment (Part number L117900).

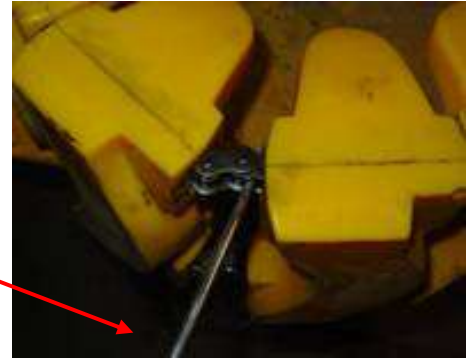

2. Once you have found the joining link, place 2 x 6mm bolts or suitable pins to hold the chain while you remove the joiner link.



3. Pull the locking bolts out and remove the chain simply by pulling it through the track segments. Then turn the track onto its other side and repeat steps 1, 2 and 3.



4. Lay segments out on the floor in the required pattern, and then feed the chain in from one end through to the other. It will assist if the chain is washed clean and soaked in diesel. If you have trouble, you can thread a piece of 3 mm wire in from the other end and connect it to the chain to help pull the chain through.



5. Once the chain is fed all the way through, install the 6mm locking pin in one end of the chain and push all the segments up tight, inserting the 6mm locking pin through the other end. Repeat this procedure with the chain on the opposite side.



6. Once both chains are pulled through and secured with pins, lay the track on its side. Place the securing pins through the link in such a manner so as to expose the holes through which you will fit the joining link.
7. With the track on its side, install the joining link from the inside to the outside so that the spring clip is on the outside. Flip the track over and repeat to the other side, remove the locking pins/bolts and the track is now ready to install. Refer to Track Installation Instructions (Page 46).



TRACK CHAIN LINK REMOVAL

If traction between the drive wheel and track is lost, increase tyre pressure in 5psi stages to compensate for wear. If traction is lost when the tyre pressure is set at 75psi, track chain links will need to be removed to tighten tracks.

1. Use the **Track Removal Instructions** to undertake this operation.
2. Once track is removed, lay track on its side.
3. You will have to pick a spot and pry the L/H segment apart to allow you to insert a 6mm locking bolt through the chain link. Then pry the R/H segment back as far as you can with a screwdriver to expose 2 full side plates (4 x pins).
4. Use chain splitter or angle grinder to grind off 2 pins that are on the outside of the 4 pins. Grind off these 2 pins to remove 1 x link. Use a pin punch to drive the pins out to release the chain section.

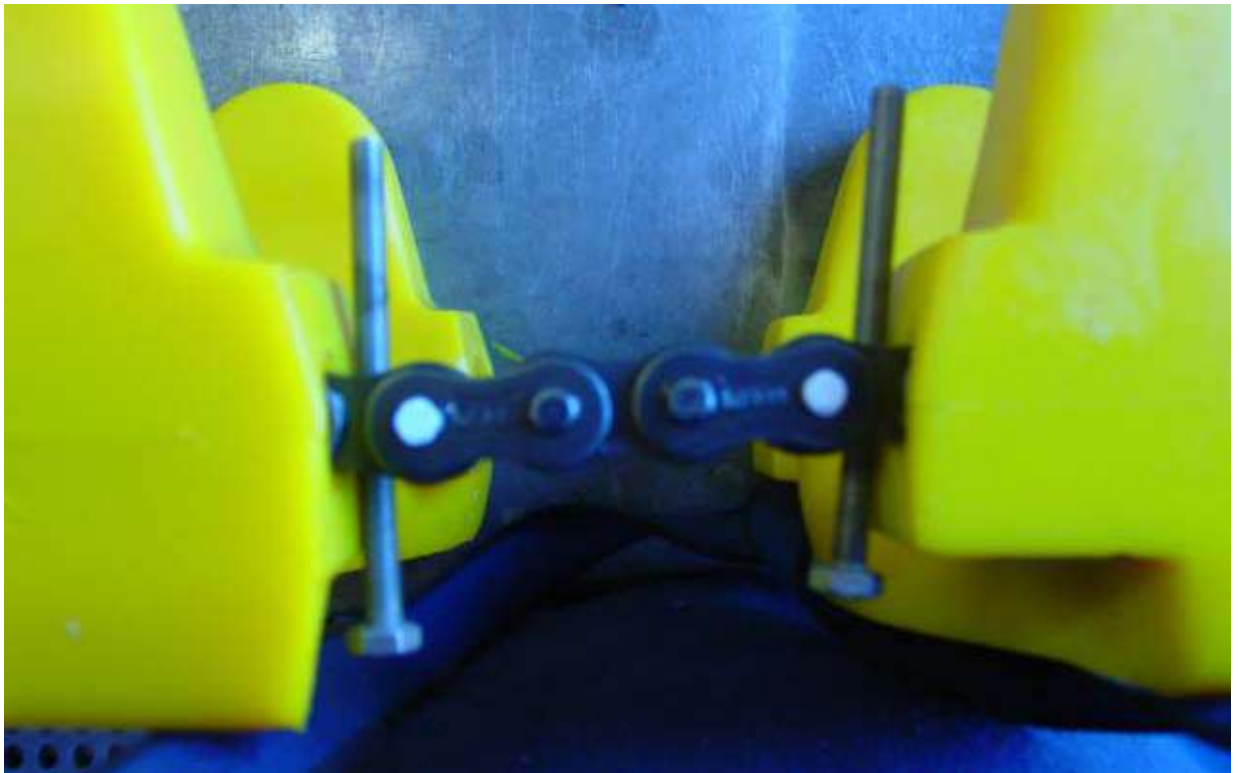

5. Turn the track over and perform the same on the other side to release the track so it is no longer joined.
6. Use Joiner Link (part number L117900) to rejoin the chain, this has now shortened the chain by one link. Turn track over and perform this to the other side.
7. Remove the 6m locking bolts on both sides, and then reinstall the tracks.

Once links are removed tyre pressure must be decreased.



spare parts

HOW TO ORDER SPARE PARTS

Spares & Mechanical Support

Phone: Aus: 1300 784 223
Int: +61 7 5593 4567

Fax: Aus: (07) 5546 7922
Int: +61 7 5546 7922

Email: australia@kanga-loader.com

Postal Address: JADEN-KANGA GROUP
UNIT 2/ 127 LAHRS RD
ORMEAU QLD 4208
AUSTRALIA

Walk-in Address: JADEN-KANGA GROUP
UNIT 2/ 127 LAHRS RD
ORMEAU QLD 4208
AUSTRALIA

1. IDENTIFY THE PART(S) REQUIRED
2. REFER TO PARTS LISTS
3. INCLUDE THE FOLLOWING INFORMATION:
 - a. Loader model
 - b. Serial Number
 - c. Engine type
 - d. Part Number required
 - e. Description
 - f. METHOD OF PAYMENT, CONTACT NUMBER and DELIVERY ADDRESS.

Note: Freight charges are additional.



DECALS

A SERIES LOADERS COMPLETE STICKER KIT – PART # 0K18582

Item #	Part #	Description
1	L118654	BACK GROUND DECAL L/H TANK YELLOW
2	L118655	BACK GROUND DECAL R/H TANK YELLOW
3	L118656	DECAL KANGA LOGO LEFT HAND [250X85]
4	L118657	DECAL KANGA LOGO RIGHT HAND [250X85]
5	L118658	DECAL KANGA POWER [MAIN ARM] A SERIES
6	L118451	NAME PLATE L/H DRIVE&LIFT&4-1 D/GA 5-6-7
7	L118431	NAME PLATE R/H DRIVE & TILT D/GA 5-6-7
8	L118550	DECAL OPERATOR SAFETY 5-6-7-8 SERIES 220 X 110
9	L118565	DECAL AUST MADE TRIANGLE
10	L118599	DECAL TRENCHING VALVE INSTRUCTIONS
11	L118594	DECAL DIAL 1100 BEFORE YOU DIG
12	L118577	DECAL THROTTLE STICKER
13	L118460	NAME PLATE AUXILLIARY VHB TAPE
14	L118596	DECAL NO SMOKING 50 MM DIA
15	L118480	NAME PLATE HYDRAULIC OIL VHB TAPE
16	L118563	DECAL TIE DOWN
17	L118561	DECAL CRUSH TRIANGLE
18	L118562	DECAL LIFT HOOK
19	L118632	DECAL ARM SAFTEY PIN
20	L118571	DECAL DANGER HOT EXHAUST
21	L118511	KEY RING KANGA
22	L118645	DECAL PASSED
23	L118664	DECAL DA725
24	L118660	DECAL DA520
25	L118663	DECAL GA724
26	L118662	DECAL DA625
27	L118661	DECAL GA624
28	L118659	DECAL GA524
29	L118646	DECAL KUBOTA POWER
30	L118669	DECAL TYRE PRESSURE 55 PSI TO 75 PSI (7&8 SERIES)
31	L118579	DECAL SWL 250-550LBS (5 Series)
32	L118665	DECAL SWL 260-573LBS (6 & 7 Series)
33	L118572	DECAL MANUAL HOLDER
34	L118671	DECAL 1300 SERVICE NUMBER

DRIVE TRAIN - ASSEMBLY DRAWING

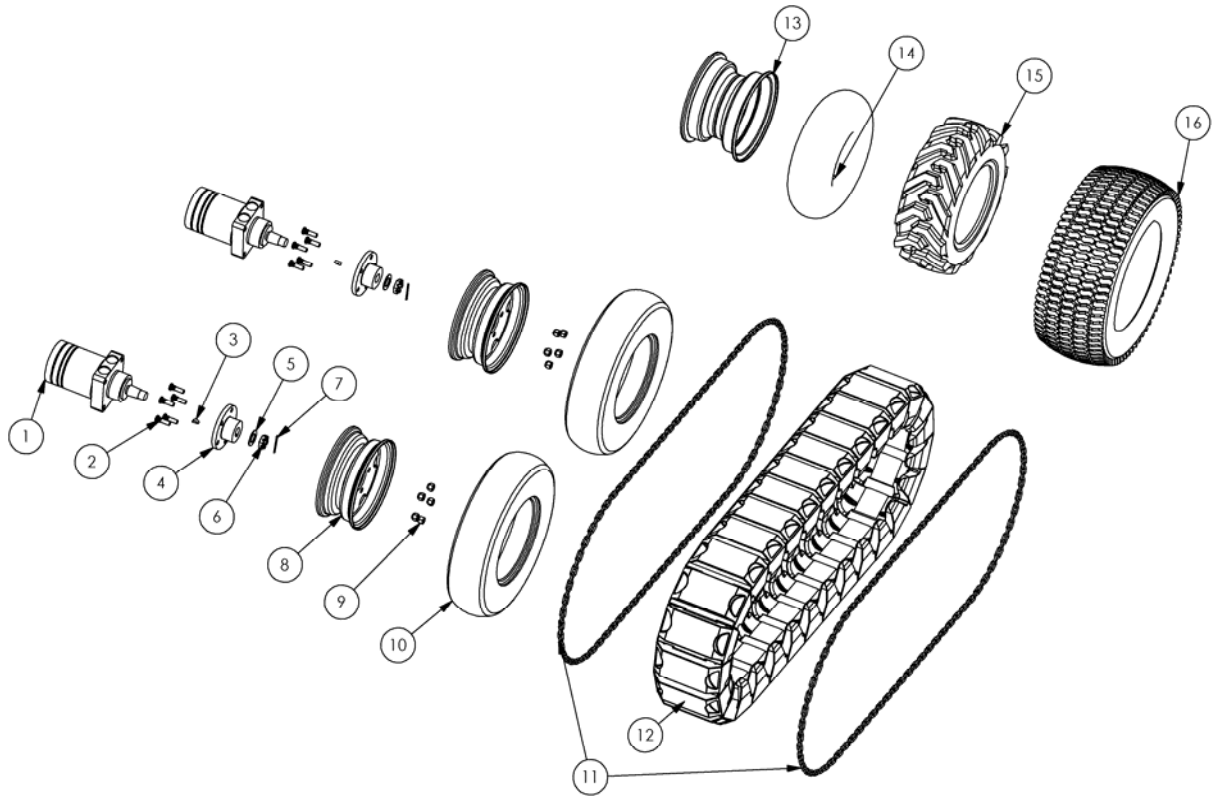



DRIVE TRAIN - PARTS LIST

No	Description	Part No	No	Description	Part No
1	MOTOR, WHEEL 5 SERIES	L112321	9	NUTS, WHEEL 7/16 UNF	L114300
	MOTOR, WHEEL 6 SERIES	L112325	10	TYRE, TRACK DRIVE, TUBELESS	L114301
	MOTOR, WHEEL 7 SERIES	L112282	11	CHAIN, ROLLER, 7 SERIES	L117607
2	STUD WHEEL, 7/16"	L112730	12	URO TRACK ASSEMBLY WITH ROLLER CHAIN	0K14313
3	DRIVE KEY	L112900	13	RIM, 6" X 10" YELLOW, SUIT 19" & 20" TYRES, 5 SERIES	L114214/Y
4	HUB DRIVE KANGA 5-6-7-8 SERIES STANDARD	L112713		RIM, 7" X 12", SUIT 23" TYRES, 6 SERIES	0K14206
	DRIVE HUB ASSEMBLY, STD	0K12714	14	TUBE, SUIT 19" LUG TYRE	L114010
	HUB DRIVE WIDE WHEEL, NO STUDS	L112708	15	5 SERIES - TYRE, 19" LUG (INCLUDING TUBE, L114010)	L114110
	DRIVE HUB ASSEMBLY, WIDE WHEEL	0K12709		5 SERIES - TYRE, 19" TURF LUG COMBO, TUBELESS	L114131
5	WASHER, 25MM	F1DBAA25		6 SERIES - TYRE, 23" LUG, TUBELESS	L114105
6	LOCK NUT	L113000	16	5 SERIES - TYRE, 20" TURF, TUBELESS	L114172
7	SPLIT PIN	F1GB3.2*63 NZPCP		6 SERIES - TYRE, 23" TURF, TUBELESS	L114106
8	RIM, TRACK YELLOW 3" X 10"	L114211			

MAIN FRAME - ASSEMBLY DRAWING

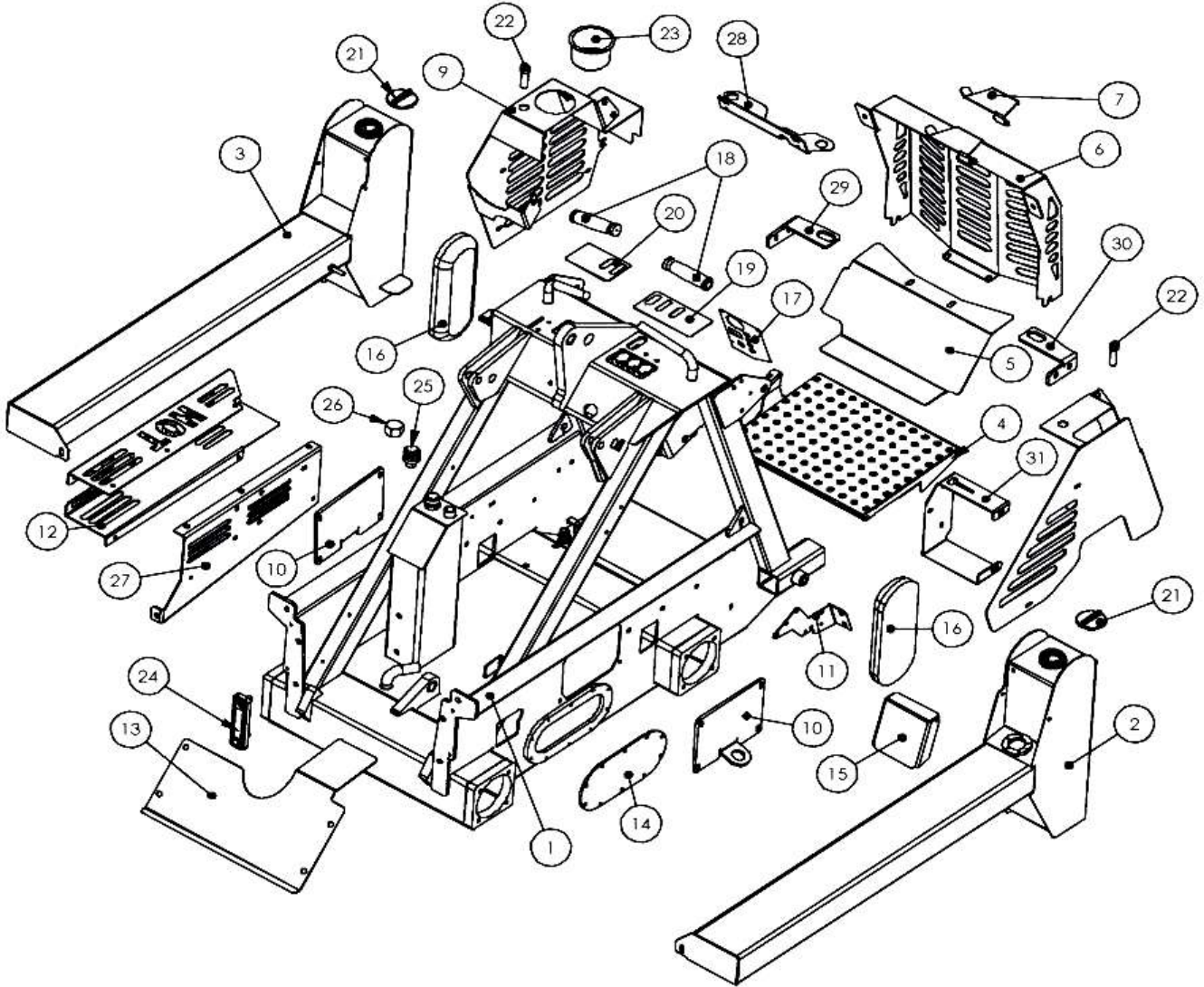



MAIN FRAME - PARTS LIST

No	Description	Part No	No	Description	Part No
1	CHASSIS - SERIES 5-6-7	0K10106	25	FILLER BREATHER 1/2" BSP	L116061
2	FUEL TANK L/H	0K20127	26	CAP NUT 1-5/16 JIC	HACP-J-F21
3	FUEL TANK R/H	0K20128	27	EXHAUST MOUNT - DIESEL	0K10106-8
4	REAR STEP ASSEMBLY	0K10106-1	28	RADIATOR MOUNT TOP – DIESEL	0K10106-3
5	RADIATOR HEAT DEFLECTOR DIESEL	0K10106-15	29	RADIATOR MOUNT R/H – DIESEL	0K10106-4
6	RADIATOR SHROUD DIESEL	0K10106-2	30	RADIATOR MOUNT L/H – DIESEL	0K10106-5
7	RADIATOR SAFETY LID DIESEL	0K10106-19	31	DONALDSON AIR CLEANER BRACKET	0K10106-12
8	TRENCHER VALVE SHROUD	0K10106-11			
9	OIL COOLER SHROUD	0K10106-14			
10	TIE DOWN & MANIFOLD COVER	0K10106-10			
11	FUEL FILTER BRACKET DIESEL	0K10106-9			
12	EXHAUST GUARD DIESEL	0K10106-13			
13	SPLASH GUARD	0K10106-23			
14	OIL TANK INSPECTION COVER	0K10104			
	GASKET, OVAL SHAPED	L116043			
15	FUEL TANK SENDER COVER	0K10106-36			
16	BUMP PAD - BLACK	L123057			
17	DASH PANEL - PETROL	L118400			
	DASH PANEL - DIESEL	L118401			
18	GRIPS, RUBBER HANDLE	L110300			
19	LEFT CONTROL LEVER PANEL	L118403			
20	RIGHT CONTROL LEVER PANEL	L118402			
21	CAP, FUEL	L122230			
22	PIN, ARM LOCKING	0K10750			
	GROMMET, 25OD 19ID 3PL	L122241			
23	CUP HOLDER BLACK	L118525			
24	5" SIGHT GAUGE	H1TA5"SIGHTGUAGE			

ARMS - ASSEMBLY DRAWING

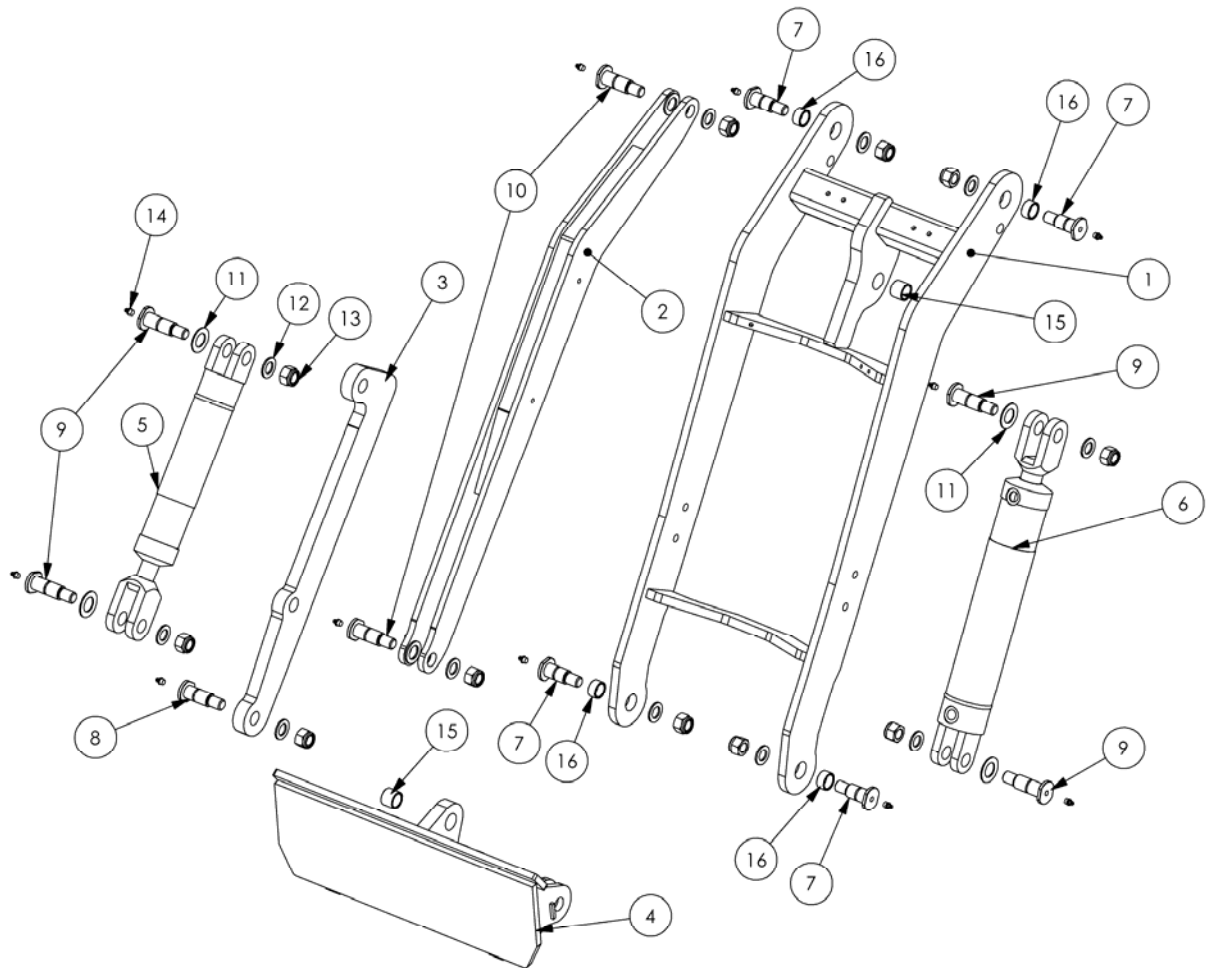



ARMS - PARTS LIST

No	Description	Part No	No	Description	Part No
1	MAIN ARM 5-6-7	0K11280	13	NUT NYLOC, M20 X 1.5 – 1 PER PIN	F1CBBBA20
2	LEVELLER ARM 5-6-7	0K11380	14	GREASE NIPPLE STRAIGHT, 1/8 BSP	L110600
3	TILT ARM 5-6-7	0K11480	15	BUSH, IRB 1616 (2 ONLY)	L111410
4	ATTACHMENT PLATE STANDARD	0K11500	16	BUSH, IRB 1610	L111210
	ATTACHMENT PLATE WIDE WHEELS	0K11502			
5	CYLINDER, TILT	L110190			
	SEAL KIT, TILT CYLINDER	L110231			
6	CYLINDER, LIFT	L110390			
	SEAL KIT, LIFT CYLINDER	L110470			
7	PIN 'A' – 4 PER LOADER	L110700			
	PIN 'A' - inc. nipple, washers & nut	0K10700			
8	PIN, 'B' - 1 PER LOADER	L110800			
	PIN 'B' - inc. nipple, washers & nut	0K10800			
9	PIN 'C' – 4 PER LOADER	L110900			
	PIN 'C' - inc. nipple, washers & nut	0K10900			
10	PIN, 'D' – 2 PER LOADER	L110810			
	PIN 'D' - inc. nipple, washers & nut	0K10810			
11	WASHER, 25mm – 4 PER LOADER	F1DBAA25			
12	WASHER, 20mm – 1 PER PIN	F1DBAA20			

PETROL ENGINE & HYDRAULICS - ASSEMBLY DRAWING

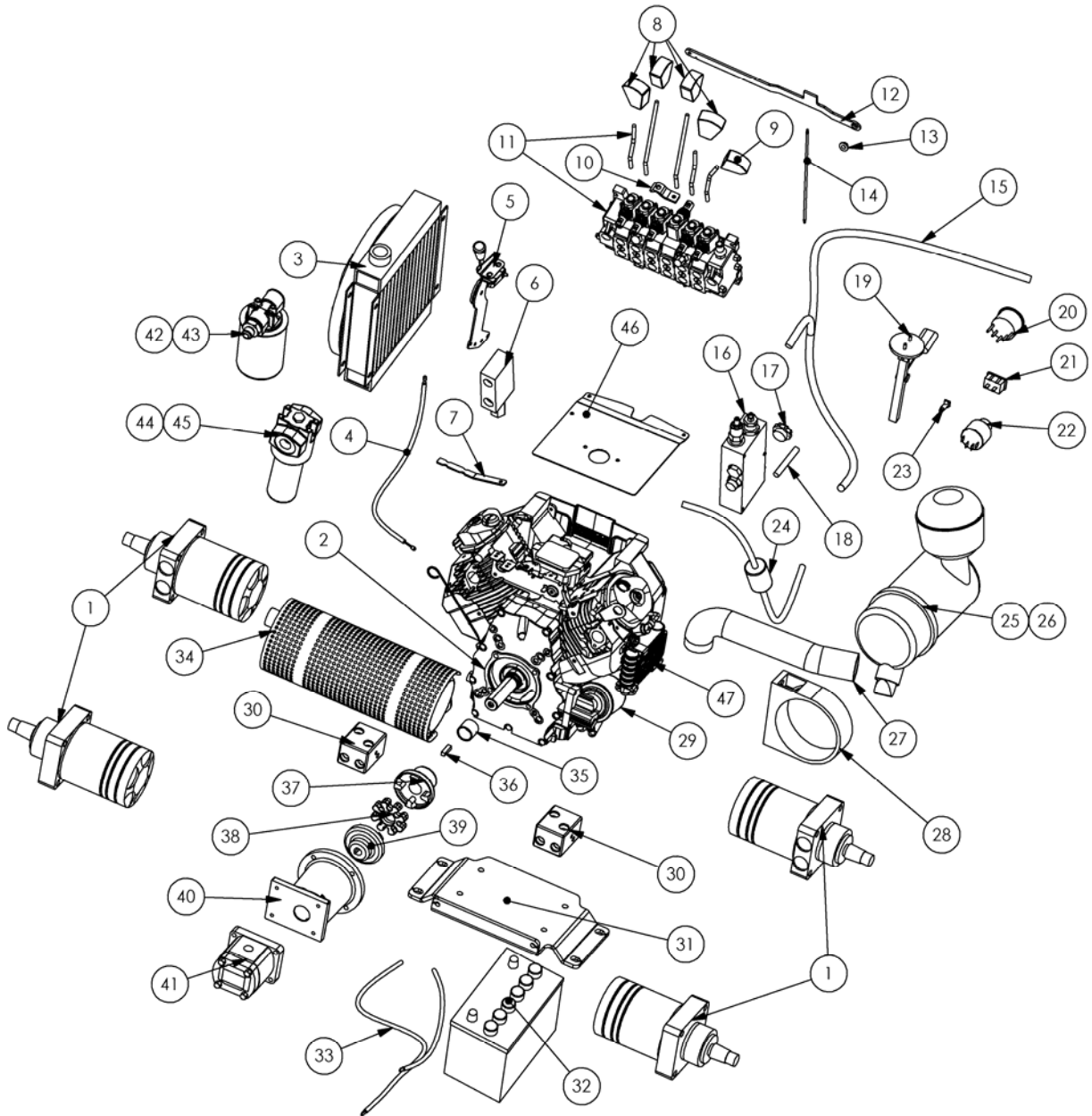



PETROL ENGINE & HYDRAULICS - PARTS LIST

No	Description	Part No	No	Description	Part No
1	MOTOR, WHEEL 5 SERIES	L112321	25	AIR CLEANER,90 DEG 5" DONALDSON COMPLETE	L120667
	MOTOR, WHEEL 6 SERIES	L112325	26	ELEMENT, AIR FILTER	L120682
	MOTOR, WHEEL 7 SERIES	L112282	27	HOSE, AIR FILTER	L120320
2	ENGINE, 24HP HONDA INC MUFFLER GX670	L116050		HOSE CLAMP x 2	L120350
	STARTER MOTOR ASSEMBLY GX670	L116050-37	28	MOUNT, 5" DONALDSON	L120672
	HOSE,ENGINE SUMP DRAIN	L110010-25	29	FILTER, OIL HONDA	L115910
3	OIL COOLER INC FAN	L149998	30	DRIVE MANIFOLD ASSEMBLY 5-6 SERIES	0K10106-33
4	CABLE, THROTTLE	L119036		DRIVE MANIFOLD ASSEMBLY 7 SERIES	0K10106-34
5	THROTTLE ASSEMBLY PETROL INC CABLE	0K10106-26	31	ENGINE MOUNT, 24HP HONDA	0K10106-22
6	VALVE OVER CENTER	L116600-1	32	MAINTENANCE FREE BATTERY, MF43	L114392
7	LOOM SOCK BRACKET	0K16852	33	BATTERY LEAD, POSITIVE	0K10106-48A
8	KNOB, CONTROL	L117270		BATTERY LEAD, NEGATIVE	0K10106-48B
9	KNOB, 4 IN 1	0K17272	34	MUFFLER, 24HP HONDA	L1VHLM4
10	LEVER POSITIONER	0K17291		GASKET, MUFFLER	L116050-13
11	VALVE, 6 BANK INC BENT LEVERS/KNOBS	0K17420	35	COUPLING SPACER	0K15561
12	AUXILLIARY STOP LEVER	0K10106-18	36	KEY, STEEL LENGTH 300mm, CUT TO 45mm	L115570
	SPRING, AUX. STOP	L113800	37	COUPLING	L115510
13	SPACER, AUX. STOP LEVER	0K13830	38	SPIDER, R82 COUPLING	L115530
14	CABLE, AUX. STOP	L113813	39	COUPLING, PUMP	L115520
15	WIRING LOOM, 24HP HONDA	0K10106-48	40	BELLHOUSING, HONDA	L115300
	WIRING LOOM, OIL PRESURE	0K10106-49	41	PUMP, 11.3CC	L114680
	WIRING LOOM, OIL COOLER	0K10106-53	42	ELEMENT, RETURN FILTER	L116442
16	VALVE, TRENCHER	L141300	43	FILTER HEAD	L116300
17	CARTRIDGE, NEEDLE VALVE & KNOB	L141300-5	44	ELEMENT, PRESSURE FILTER	L116420
18	EXTENSION,TRENCHER VALVE	0K41306	45	FILTER, PRESSURE COMPLETE	L116410
19	FUEL SENDER ASSY	0K10106-57	46	AIR CLEANER PLATE 24 HP	0K20373
20	GAUGE FUEL E-1/2-F	L122236	47	OIL PRESSURE SWITCH	L116050-51
21	HOUR CLOCK	L121500			
22	SWITCH, KEY	L115743			
23	LIGHT, AMBER, CHARGE	L115855			
	LIGHT, RED, OIL	L115857			
24	FILTER, Z15 FUEL INLINE	L115942			

DIESEL ENGINE & HYDRAULICS - ASSEMBLY DRAWING

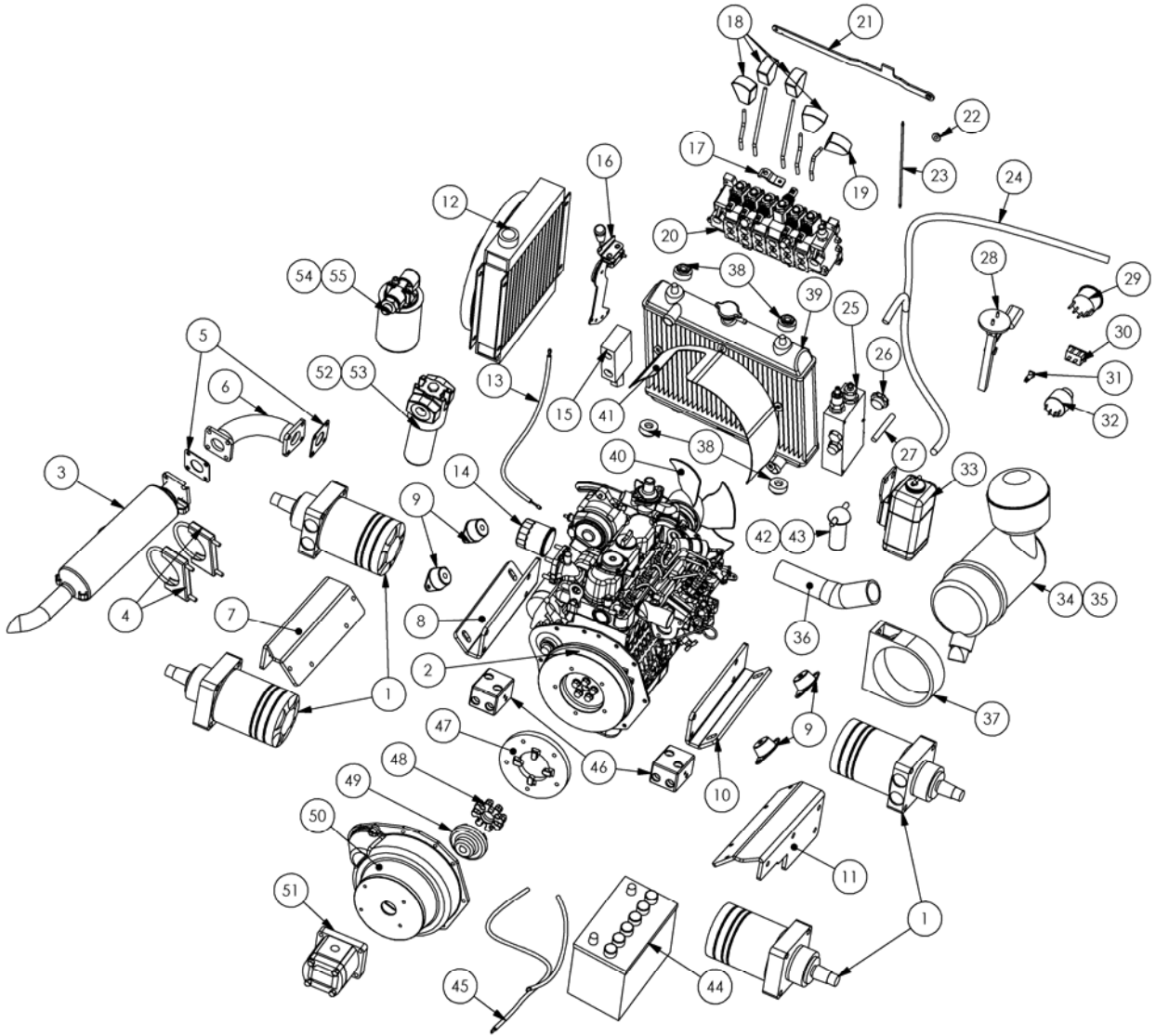



DIESEL ENGINE & HYDRAULICS - PARTS LIST

No	Description	Part No	No	Description	Part No
1	MOTOR, WHEEL 5 SERIES	L112321	28	FUEL SENDER ASSY	0K10106-57
	MOTOR, WHEEL 6 SERIES	L112325	29	GAUGE FUEL E-1/2-F	L122236
	MOTOR, WHEEL 7 SERIES	L112282	30	HOUR CLOCK	L121500
2	ENGINE, 20HP KUBOTA ENGINE & ASSY D722	L115966	31	LIGHT, AMBER, CHARGE	L115855
	ENGINE, 25HP KUBOTA ENGINE & ASSY D902	L115965		LIGHT, GREEN, GLOW PLUG	L115856
	HOSE,ENGINE SUMP DRAIN	L110010-25		LIGHT, RED, OIL	L115857
3	MUFFLER, 20HP	0K15960		LIGHT, BLUE, WATER	L115858
	MUFFLER KIT, 25HP	L115965-6	32	SWITCH, KEY	L115965-9
4	CLAMP, EXHAUST	L118920	33	RESERVE TANK, RADIATOR	L115965-2
5	GASKET, MUFFLER	L115790	34	AIR CLEANER,90 DEG 5" DONALDSON COMPLETE	L120667
6	FLEX, EXHAUST	L118910	35	ELEMENT, AIR FILTER	L120682
7	ENGINE MOUNT, R/H	0K10106-7	36	HOSE, AIR FILTER	L120320
8	ENGINE MOUNT, 20HP R/H	0K10106-21		HOSE CLAMP x 2	L120350
	ENGINE MOUNT, 25HP R/H	0K10106-17	37	MOUNT, 5" DONALDSON	L120672
9	ENGINE MOUNT, RUBBER	L115700	38	CUSHION, RADIATOR	L115965-8
10	ENGINE MOUNT, 20HP L/H	0K10106-20	39	RADIATOR KIT	L115965-5
	ENGINE MOUNT, 25HP L/H	0K10106-16	40	FAN, 4 BLADE, 20HP	L115956
11	ENGINE MOUNT, L/H	0K10106-6		FAN, 300 MM, 25HP	L115965-1
12	OIL COOLER INC FAN	L149998	41	FAN SHROUD	0K10106-24
13	CABLE, THROTTLE DIESEL	L119040	42	FILTER, FUEL	L120400
14	FILTER, OIL KUBOTA	L120500	43	FUEL FILTER KIT 3CYL	L115965-10
15	VALVE OVER CENTER	L116600-1	44	BATTERY, MF43	L114392
16	THROTTLE ASSEMBLY DIESEL INC CABLE	0K10106-27	45	BATTERY LEAD, POSITIVE	0K10106-48A
17	LEVER POSITIONER	0K17291		BATTERY LEAD, NEGATIVE	0K10106-48B
18	KNOB, CONTROL	L117270	46	DRIVE MANIFOLD ASSEMBLY 5-6 SERIES	0K10106-33
19	KNOB, 4 IN 1	0K17272		DRIVE MANIFOLD ASSEMBLY 7 SERIES	0K10106-34
20	VALVE, 6 BANK INC LEVERS	L117400	47	DRIVE COUPLING, 20/25 HP	0K15545
21	AUXILLIARY STOP LEVER	0K10106-18		SPACER, 20HP ONLY	0K15546
	SPRING, AUX. STOP	L113800	48	SPIDER, 20/25 HP	L115531
22	SPACER, AUX. STOP LEVER	0K13830	49	COUPLING, 20/25 HP	L115521
23	CABLE, AUX. STOP	L113813	50	BELLHOUSING, 20/25 HP	0K15213
24	WIRING LOOM, 20HP	0K10106-50	51	PUMP, 12.5CC, 25HP	L114621
	WIRING LOOM, 25HP	0K10106-51		PUMP, 11.3CC, 20HP	L114680
	WIRING LOOM, OIL COOLER	0K10106-53	52	ELEMENT, PRESSURE FILTER	L116420
25	VALVE, TRENCHER	L141300	53	FILTER, PRESSURE COMPLETE	L116410
26	CARTRIDGE, NEEDLE VALVE & KNOB	L141300-5	54	ELEMENT, RETURN FILTER	L116442
27	EXTENSION,TRENCHER VALVE	0K41306	55	FILTER HEAD	L116300

HYDRAULIC CONNECTIONS – SCHEMATIC

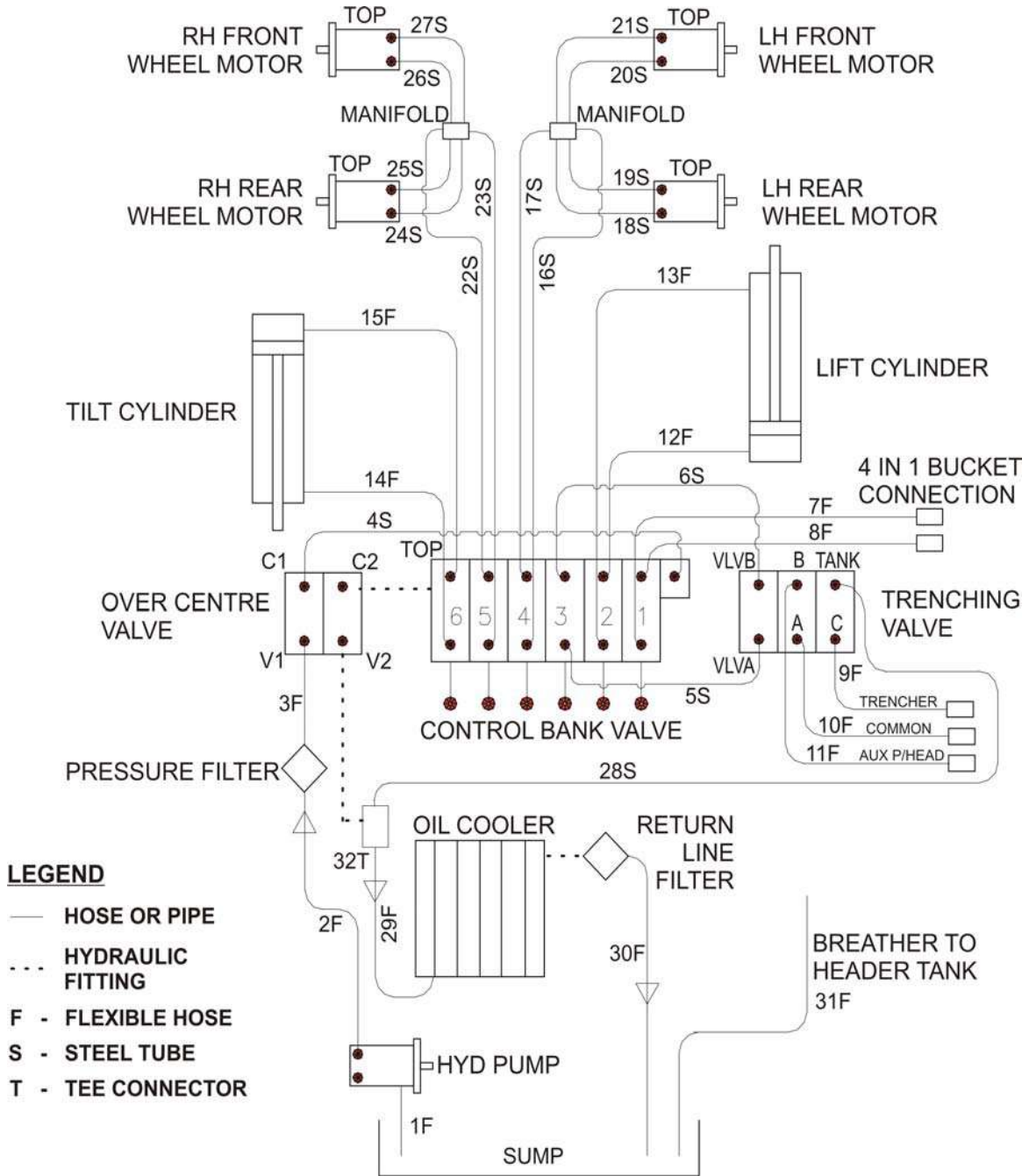



HYDRAULIC CONNECTIONS - Series 5, 6 & 7

Item No.	Part No.	Description	Hose ID	Hose Length		Hose Tail	Hose Tail
		(F = FLEXIBLE HOSE, S = STEEL TUBE, C = CONNECTOR)	inch	mm	inch		
1F	0K16004	Tank to Pump Intake - Suction Hose Petrol		350	1.39	nil	
1F	0K16005	Tank to Pump Intake - Suction Hose Diesel		260	1.03	nil	
2F	L110010-27	Pump to Pressure Filter	1/2"	750	2.98	3/4" JIC FEMALE	3/4" JIC FEMALE
3F	L110010-26	Pressure Filter to Over Centre Valve	1/2"	400	1.59	7/8" JIC FEMALE	7/8" JIC FEMALE
4S	L110040-4SA	Tube, Valve to Over Centre	5/8 od	410	1.63	7/8" JIC & SHORT SLEEVE	TUBE NUT 7/8 JIC & SLEEVE
5S	L110040-28	Tube, Trencher VLVA Bottom Valve	5/8 od	395	1.57	7/8" JIC FEMALE	NUT 7/8 JIC & SLEEVE x 2
6S	L110040-27	Tube, Trencher VLVB Top Valve	5/8 od	425	1.69	7/8" JIC FEMALE	NUT 7/8 JIC & SLEEVE x 2
7F	L110010-29QRCM	Hose, 4-1 Loader inc QRC Male	1/2"	625	2.48	7/8" JIC FEMALE	1/2" BSPP MALE
8F	L110010-29QRCF	Hose, 4-1 Loader inc QRC Female	1/2"	625	2.48	7/8" JIC FEMALE	1/2" BSPP MALE
9F	L110010-31QRCM	Hose, Trencher Valve C QRC Male	1/2"	530	2.10	7/8" JIC FEMALE	1/2" BSPP MALE
10F	L110010-33QRCF	Hose, Trencher Valve A QRC Female	1/2"	490	1.94	7/8" JIC FEMALE	1/2" BSPP MALE
11F	L110010-32QRCM	Hose, Trencher Valve B QRC Male	1/2"	555	2.20	7/8" JIC FEMALE	1/2" BSPP MALE
12F	L110010-34	Hose, LIFT CYLINDER BOTTOM TO VALVE TOP	3/8"	825	3.27	9/16" JIC FEMALE	9/16" JIC FEMALE
13F	L110010-35	Hose, LIFT CYLINDER TOP TO VALVE BOTTOM	3/8"	470	1.87	9/16" JIC FEMALE	9/16" JIC FEMALE
14F	L110010-23	HOSE, TILT RAM TOP TO VALVE BOTTOM	3/8"	2,190	8.69	9/16" JIC FEMALE	9/16" JIC FEMALE
15F	L110010-24	HOSE, TILT RAM BOTTOM TO VALVE TOP	3/8"	1,910	7.58	9/16" JIC FEMALE	9/16" JIC FEMALE
16S	L110040-24	TUBE, VALVE BOTTOM TO L/H MANIFOLD	5/8" od	850	3.37	1/16 JIC & SLEEVE	NUT 7/8 JIC & SLEEVE x 2
17S	L110040-23	TUBE, VALVE TOP TO L/H MANIFOLD	5/8 od	883	3.50	1/16 JIC & SLEEVE	NUT 7/8 JIC & SLEEVE x 2
18S	L110040-18	TUBE, L/H REAR MOTOR BOTTOM	5/8 od	315	1.25	1/16 JIC & SLEEVE	NUT 7/8 JIC & SLEEVE x 2
19S	L110040-17	TUBE, L/H REAR MOTOR TOP	5/8 od	265	1.05	1/16 JIC & SLEEVE	NUT 7/8 JIC & SLEEVE x 2
20S	L110040-16	TUBE, L/H FRONT MOTOR BOTTOM	5/8 od	370	1.47	1/16 JIC & SLEEVE	NUT 7/8 JIC & SLEEVE x 2
21S	L110040-15	TUBE, L/H FRONT MOTOR TOP	5/8 od	365	1.45	1/16 JIC & SLEEVE	NUT 7/8 JIC & SLEEVE x 2
22S	L110040-26	TUBE, VALVE TOP TO R/H BLOCK	5/8 od	830	3.29	1/16 JIC & SLEEVE	NUT 7/8 JIC & SLEEVE x 2
23S	L110040-25	TUBE, VALVE BOTTOM TO R/H BLOCK	5/8 od	790	3.13	1/16 JIC & SLEEVE	NUT 7/8 JIC & SLEEVE x 2
24S	L110040-19	TUBE, R/H REAR MOTOR BOTTOM	5/8 od	290	1.15	1/16 JIC & SLEEVE	NUT 7/8 JIC & SLEEVE x 2
25S	L110040-20	TUBE, R/H REAR MOTOR TOP	5/8 od	298	1.18	1/16 JIC & SLEEVE	NUT 7/8 JIC & SLEEVE x 2
26S	L110040-21	TUBE, R/H FRONT MOTOR BOTTOM	5/8 od	390	1.55	1/16 JIC & SLEEVE	NUT 7/8 JIC & SLEEVE x 2
27S	L110040-22	TUBE, R/H FRONT MOTOR TOP	5/8 od	340	1.35	1/16 JIC & SLEEVE	NUT 7/8 JIC & SLEEVE x 2
28S	L110040-29	TUBE, TRENCHER TO O/C VALVE	5/8 od	510	2.02	1/16 JIC & SLEEVE	NUT 7/8 JIC & SLEEVE x 2
29F	L110010-30	HOSE, OIL COOLER BOTTOM	1/2"	840	3.33	7/8" JIC FEMALE	7/8" JIC FEMALE
30F	L110010-28	HOSE, OIL COOLER TOP, OIL FILTER TO SUMP	1/2"	325	1.29	7/8" JIC FEMALE	7/8" JIC FEMALE
31F	H1HO-R6---06	BREATHER HOSE TO HEADER TANK, HYD HOSE TEXTILE BRAID 3/8" 27 BAR, PER MTR		1,050	4.17		
32T	HAT-JJJ-M14M14F14	TEE, MALE-7/8 JIC MALE-7/8 JIC FEMALE-7/8 JIC					



specification

SPECIFICATIONS - 5 Series

PERFORMANCE	GA-524		DA-520	
Max. Lift Capacity	250 kg	550 lbs	250 kg	550 lbs
Travel Speed	7.5 km/h	4.6 mph	7.5 km/h	4.6 mph
Operating Weight (inc. 4in1 Bucket)	860 kg	1892 lbs	930 kg	2046 lbs
Fuel Capacity	49 L	12.94 US gal	49 L	12.94 US gal
ENGINE				
Manufacturer	Honda GX670		Kubota D722	
Power	17.9 kW	24 hp	15 kW	20 hp
DRIVE SYSTEM				
Drive Control	Soft Touch Hand Levers		Soft Touch Hand Levers	
Throttle Control	Hand Lever		Hand Lever	
Wheels	Direct Drive Hydraulic Motors		Direct Drive Hydraulic Motors	
HYDRAULICS				
Gear Pump Displacement	11.3 cc/rev	0.69 cu.in/rev	11.3 cc/rev	0.69 cu.in/rev
Pump Output	40.7 L/min	10.75 US gal/min	40.7 L/min	10.75 US gal/min
System Pressure	203 bar	2950 psi	203 bar	2950 psi
Hyd. Reservoir Capacity	72 L	19 US gal	72 L	19 US gal
BUCKETS				
Standard Bucket Capacity	0.1 m ³	3.5 cu.ft	0.1 m ³	3.5 cu.ft
4 in 1 Bucket Capacity	0.1 m ³	3.5 cu.ft	0.1 m ³	3.5 cu.ft
DIMENSIONS				
A Max Operating Height	2460 mm	96.9 "	2460 mm	96.9 "
B Height to Hinge Pin	1815 mm	71.5 "	1815 mm	71.5 "
C Overall Height	1300 mm	51.2 "	1300 mm	51.2 "
D Overall Length With Bucket	2200 mm	86.6 "	2200 mm	86.6 "
E Overall Wheel Width	1010 mm	39.8 "	1010 mm	39.8 "
F Bucket Reach at 40°	455 mm	17.9 "	455 mm	17.9 "
Bucket Max Reach (Level)	1060 mm	41.7 "	1060 mm	41.7 "
G Dump Height Std. Bucket	1090 mm	42.9 "	1090 mm	42.9 "
Dump Height 4 in 1 Bucket	1815 mm	41.7 "	1815 mm	41.7 "
H Bucket Width	1050 mm	41.3 "	1050 mm	41.3 "
I Bucket Max Roll Back	40°		40°	
J Bucket Max Dump Angle	60°		60°	
K Ground Penetration	470 mm	18.5 "	470 mm	18.5 "
L Overall Length Less Bucket	1660 mm	65.4 "	1660 mm	65.4 "
M Ground Clearance	140 mm	5.5 "	140 mm	5.5 "
N Angle of Departure	35°		35°	
Approach Angle	90°		90°	

DIMENSIONS - 5 Series

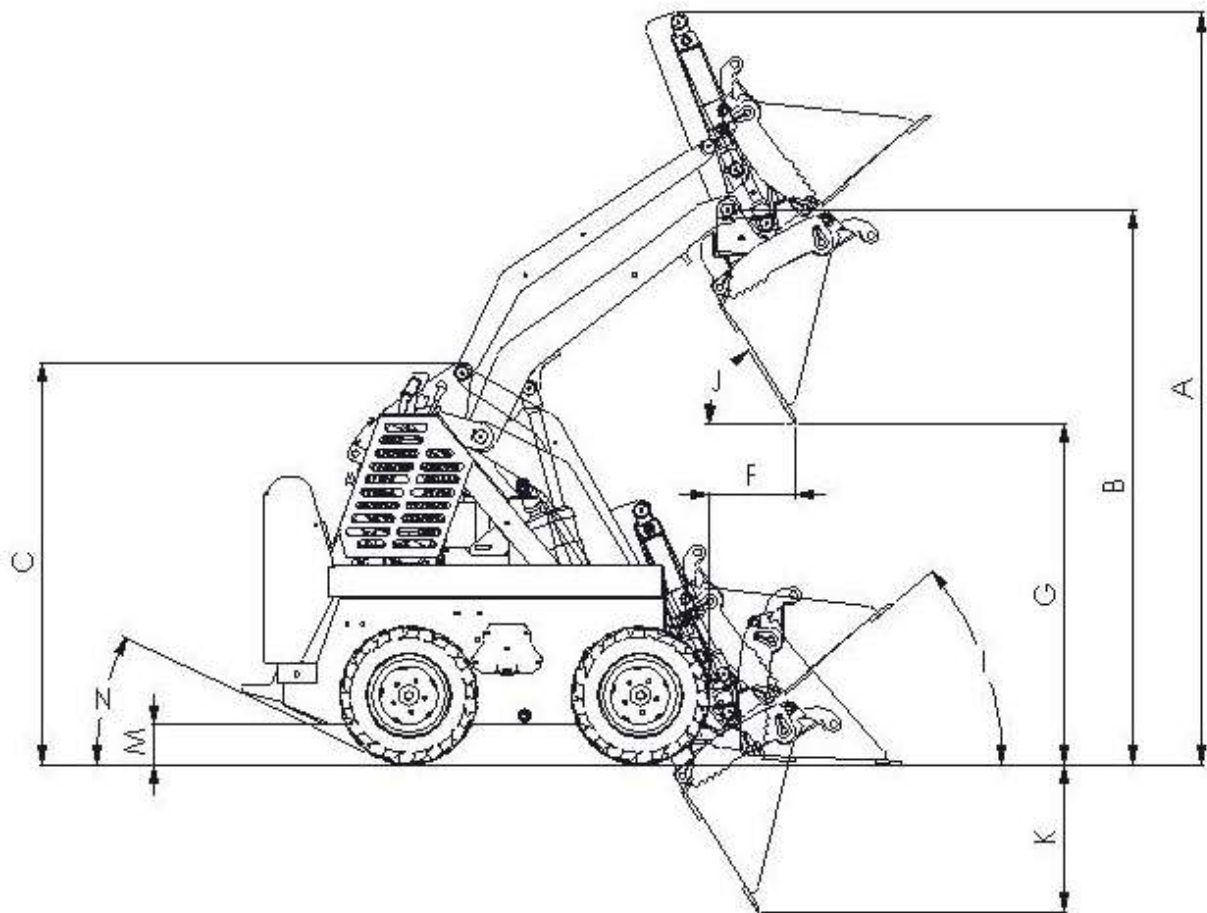
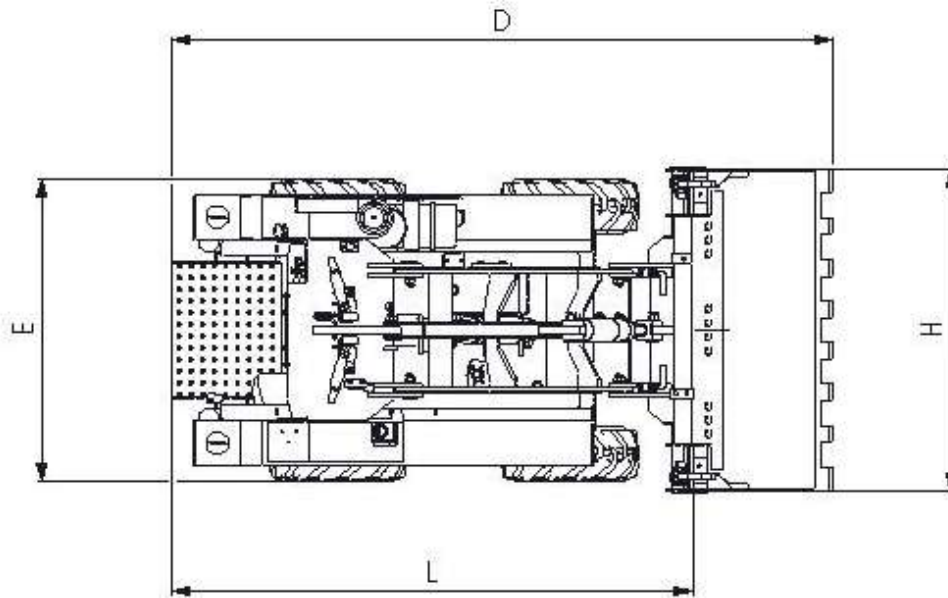



SPECIFICATIONS - 6 Series

PERFORMANCE	GA-624		DA-625	
Max. Lift Capacity	260 kg	573 lbs	260 kg	573 lbs
Travel Speed	8.2 km/h	5.1 mph	7.5 km/h	4.7 mph
Operating Weight (inc. 4in1 Bucket)	890 kg	1962 lbs	975 kg	2150 lbs
Fuel Capacity	49 L	12.94 US gal	49 L	12.94 US gal
ENGINE				
Manufacturer	Honda GX670		Kubota D902	
Power	17.9 kW	24 hp	18.5 kW	25 hp
DRIVE SYSTEM				
Drive Control	Soft Touch Hand Levers		Soft Touch Hand Levers	
Throttle Control	Hand Lever		Hand Lever	
Wheels	Direct Drive Hydraulic Motors		Direct Drive Hydraulic Motors	
HYDRAULICS				
Gear Pump Displacement	11.3 cc/rev	0.69 cu.in/rev	12.5 cc/rev	0.76 cu.in/rev
Pump Output	40.7 L/min	10.75 US gal/min	45 L/min	11.9 US gal/min
System Pressure	203 bar	2950 psi	220 bar	3200 psi
Hyd. Reservoir Capacity	72 L	19 US gal	72 L	19 US gal
BUCKETS				
Standard Bucket Capacity	0.1 m ³	3.5 cu.ft	0.1 m ³	3.5 cu.ft
4 in 1 Bucket Capacity	0.1 m ³	3.5 cu.ft	0.1 m ³	3.5 cu.ft
DIMENSIONS				
A Max Operating Height	2500 mm	98.4 "	2500 mm	98.4 "
B Height to Hinge Pin	1855 mm	73 "	1855 mm	73 "
C Overall Height	1340 mm	52.8 "	1340 mm	52.8 "
D Overall Length With Bucket	2200 mm	86.6 "	2200 mm	86.6 "
E Overall Wheel Width	1030 mm	40.6 "	1030 mm	40.6 "
F Bucket Reach at 40°	410 mm	16.1 "	410 mm	16.1 "
Bucket Max Reach (Level)	1020 mm	40.1 "	1020	40.1 "
G Dump Height Std. Bucket	1130 mm	44.5 "	1130 mm	44.5 "
Dump Height 4 in 1 Bucket	1855 mm	43.3 "	1855 mm	43.3 "
H Bucket Width	1050 mm	41.3 "	1050 mm	41.3 "
I Bucket Max Roll Back	40°		40°	
J Bucket Max Dump Angle	60°		60°	
K Ground Penetration	430 mm	16.9 "	430 mm	16.9 "
L Overall Length Less Bucket	1660 mm	65.4 "	1660 mm	65.4 "
M Ground Clearance	185 mm	7.3 "	185 mm	7.3 "
N Angle of Departure	40°		40°	
Approach Angle	90°		90°	

DIMENSIONS - 6 Series

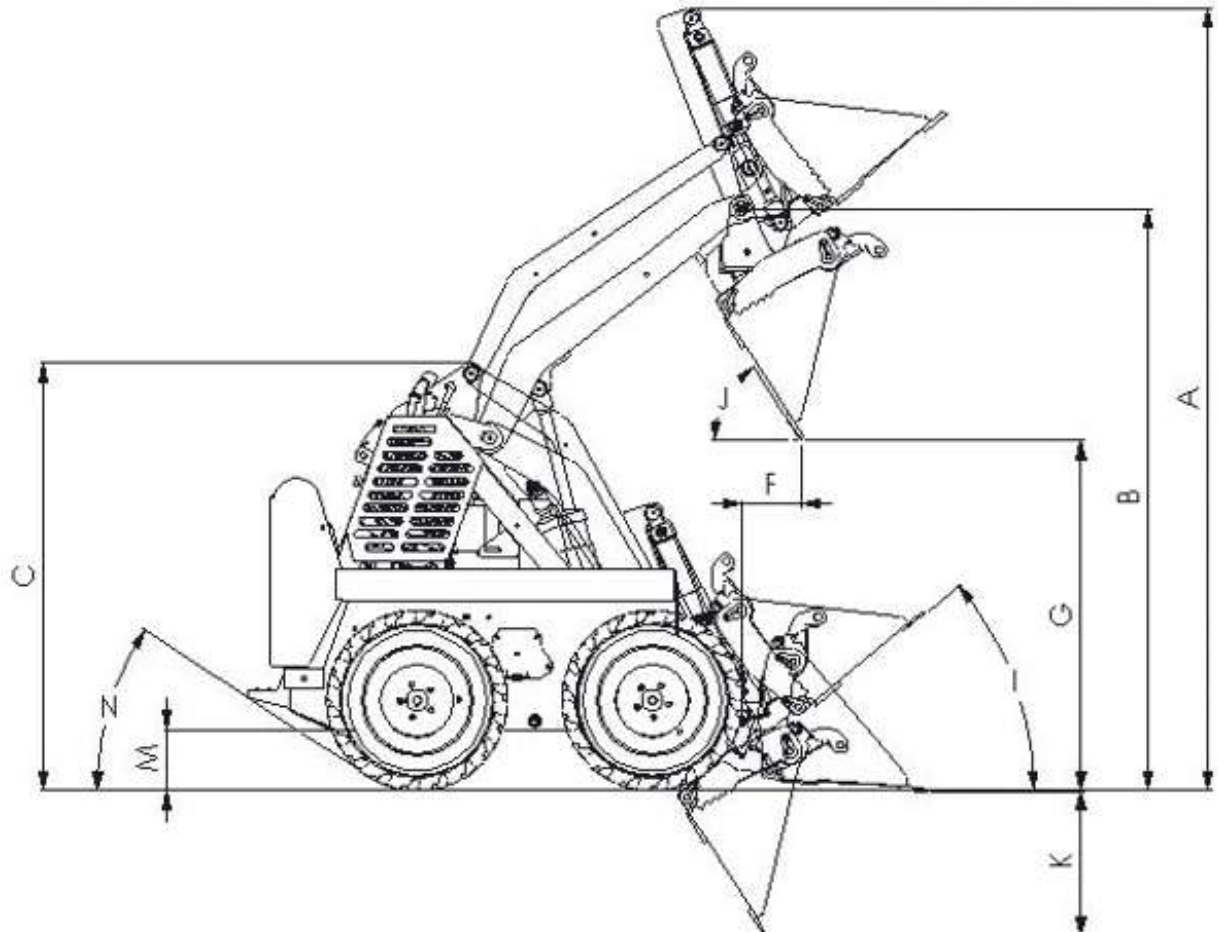
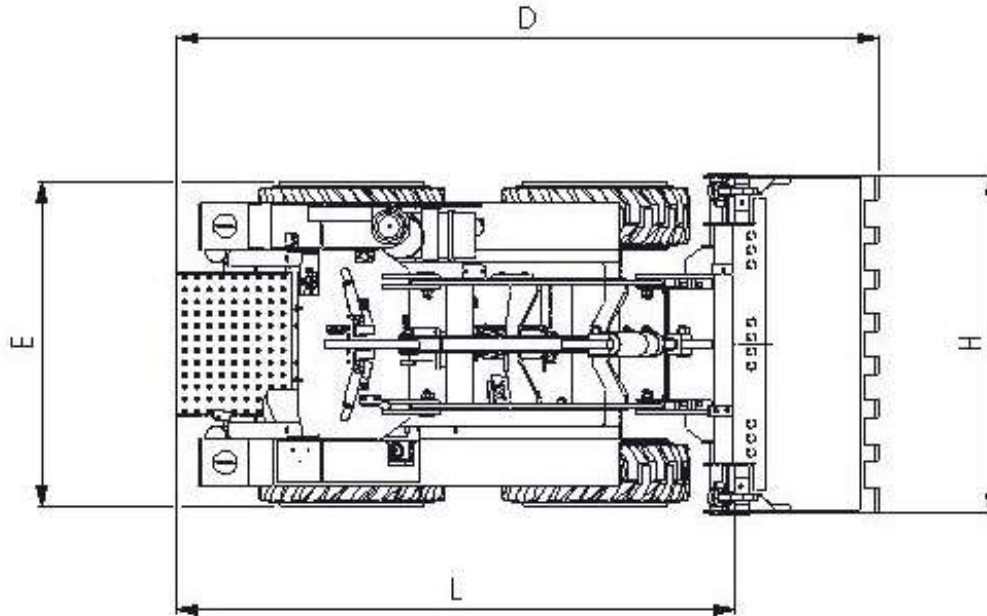



SPECIFICATIONS - 7 Series

PERFORMANCE	GA-724		DA-725	
Max. Lift Capacity	260 kg	573 lbs	260 kg	573 lbs
Travel Speed	6.4 km/h	4 mph	6.4 km/h	4 mph
Operating Weight (inc. 4in1 Bucket)	940 kg	2072 lbs	1025 kg	2260 lbs
Fuel Capacity	49 L	12.94 US gal	49 L	12.94 US gal
ENGINE				
Manufacturer	Honda GX670		Kubota D902	
Power	17.9 kW	24 hp	18.5 kW	25 hp
DRIVE SYSTEM				
Drive Control	Soft Touch Hand Levers		Soft Touch Hand Levers	
Throttle Control	Hand Lever		Hand Lever	
Tracks	Direct Drive Hydraulic Motors		Direct Drive Hydraulic Motors	
HYDRAULICS				
Gear Pump Displacement	11.3 cc/rev	0.69 cu.in/rev	12.5 cc/rev	0.76 cu.in/rev
Pump Output	40.7 L/min	10.75 US gal/min	45 L/min	11.9 US gal/min
System Pressure	203 bar	2950 psi	220 bar	3200 psi
Hyd. Reservoir Capacity	72 L	19 US gal	72 L	19 US gal
BUCKETS				
Standard Bucket Capacity	0.1 m ³	3.5 cu.ft	0.1 m ³	3.5 cu.ft
4 in 1 Bucket Capacity	0.1 m ³	3.5 cu.ft	0.1 m ³	3.5 cu.ft
DIMENSIONS				
A Max Operating Height	2510 mm	98.8 "	2510 mm	98.8 "
B Height to Hinge Pin	1865 mm	73.4 "	1865 mm	73.4 "
C Overall Height	1350 mm	53.1 "	1350 mm	53.1 "
D Overall Length With Bucket	2200 mm	86.6 "	2200 mm	86.6 "
E Overall Track Width	1040 mm	41 "	1040 mm	41 "
F Bucket Reach at 40°	400 mm	15.7 "	400 mm	15.7 "
Bucket Max Reach (Level)	1010 mm	39.8 "	1010 mm	39.8 "
G Dump Height Std. Bucket	1140 mm	44.9 "	1140 mm	44.9 "
Dump Height 4 in 1 Bucket	1865 mm	43.7 "	1865 mm	73.4 "
H Bucket Width	1050 mm	41.3 "	1050 mm	41.3 "
I Bucket Max Roll Back	40°		40°	
J Bucket Max Dump Angle	60°		60°	
K Ground Penetration	420 mm	16.5 "	420 mm	16.5 "
L Overall Length Less Bucket	1660 mm	65.4 "	1660 mm	65.4 "
M Ground Clearance	195 mm	7.7 "	195 mm	7.7 "
N Angle of Departure	41°		41°	
Approach Angle	90°		90°	

DIMENSIONS - 7 Series

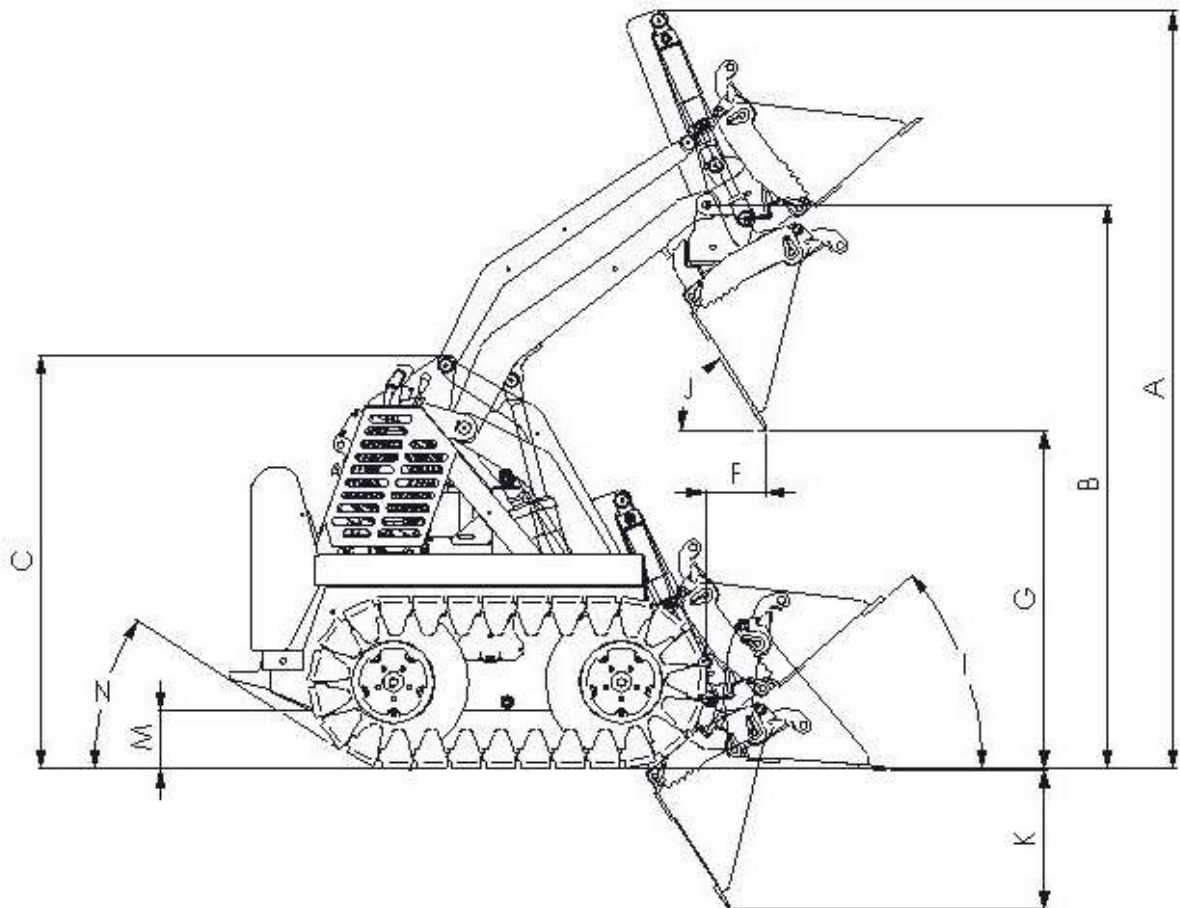
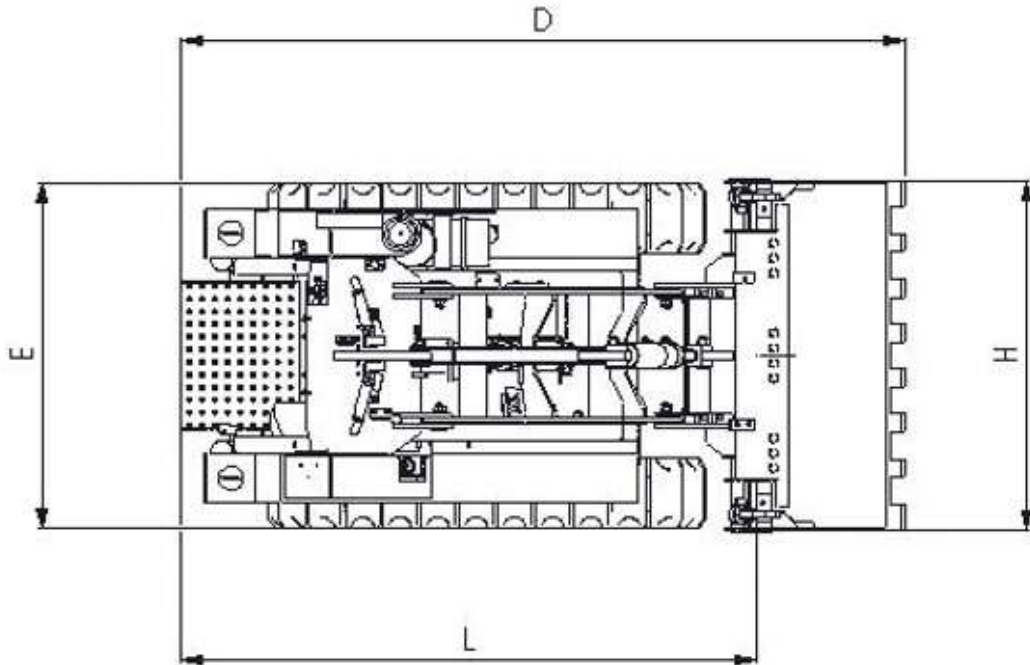

attachments

HYDRAULIC ATTACHMENT CONNECTIONS

Kanga Loaders are fitted with hydraulic quick release couplings (QRC) to connect the different attachments. The QRCs are paired as male and female to ensure correct hose connections.

COLOUR CODING OF QRC'S FOR ATTACHMENTS.

Left Side : Controlled by the Auxiliary lever on the Control Panel.

Yellow

B MALE QRC for Power Head, Under Road Borer, Mixer Bowl, Wood-Chipper, Log Splitter, Rotating Log Grab, Rock Breaker.

Black

A FEMALE QRC for Power Head, Trenchers, Under Road Borer, Backhoe, Rotary hoe, Vibrating Plough, Mixer Bowl, Wood Chipper, Log Splitter, Rotating Log Grab, Rock Breaker, Bucket Broom, Angle Bucket Broom, Rod Hammer & Drill.

Red

C MALE QRC TRENCHER VALVE for Trenchers, Backhoe, Rotary Hoe, Vibrating Plough, Bucket Broom, Angle Bucket Broom, Rod Hammer, Post Mast Rod Hammer & Drill.

Right Side: Controlled by the 4:1 Lever on the Control Panel.

Blue

4&1 FEMALE QRC for 4&1 Bucket, Stump Grinder Slew, Backfill Blade, Rotating Log Grab, Kerb Clamp, Grapple Bucket, Plant Box Lifter, Angle Bucket Broom.

White

4&1 MALE QRC for 4&1 Bucket, Stump Grinder Slew, Backfill Blade, Rotating Log Grab, Kerb Clamp, Grapple Bucket, Plant Box Lifter, Angle Bucket Broom.

Purple

Tank return line - Post Mast Rod Hammer & Drill. (If fitted)

Green

Case drain - Hydraulic Stump Grinder, Poly Pipe Layer, Wood Chipper. (If fitted)

Hydraulic connections as viewed from the front.

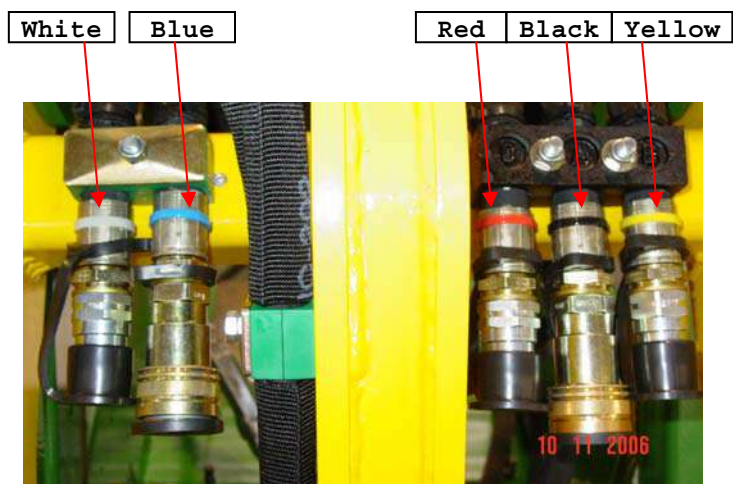

POWER HEAD OPERATING INSTRUCTIONS

FITTING OF POWER HEAD:

Drive the Loader to the attachment and couple the attachment plate onto the attachment. Raise the Power Head slightly and engage the locking pins fully. Turn the engine off and push the AUX Control Lever forwards and backwards to release any hydraulic line pressure. Clean the hydraulic fittings (QRCs) and then connect them to connections A & B. (see "Hydraulics General Description" section).

Removal procedure is the reverse order of the above. Remember to always reconnect the attachment hoses into one another to stop dirt entering the hydraulic system, or fit the dust caps supplied.

FITTING THE AUGER:

Once fitted to the Loader, raise the Power Head high enough to allow the auger to be positioned into the Power Head's square drive shaft. Drive the Power Head forward positioning the drive into the auger, aligning the locking pin holes.



CAUTION: Large auger fitting is a 2 person operation

Insert the locking pins and lock in place.

PRE-OPERATION CHECK:

Ensure that the Power Head is securely attached to the Kanga Loader. Check that the couplings are engaged and check for leaks. Tighten/repair as required.



CAUTION: Prior to commencing work, read the **Safety Rules** of this Kanga Loader Manual

OPERATING INSTRUCTIONS:

Inspect the cutting tips and teeth. Ensure that they are in good condition and firmly attached.

**Note: Teeth should display slight movement.
Check that bolts securing the pilot are tight.**

Start the auger turning in a clockwise direction by activating the "AUX" lever downwards. Lower the auger by pushing the "ARM" lever forward. If the ground is hard the front wheels of the Kanga Loader will lift off the ground. As the auger cuts into the ground the arc of the arm travel will move it out of vertical. To keep the auger vertical, move the Kanga Loader backward or forward slightly to compensate.

Continually clear the hole during digging by raising the auger up (pull back on the "ARM" lever).

Drill a "trial" hole in a clear area to practice all operations and to become familiar with the procedure.



CAUTION: Prior to commencing any digging operations, check with the Local Authorities and the land owner that there are no buried services (Power, phone, water, gas, sewage etc) in the vicinity.

Australia ONLY: Phone 1100 "DIAL BEFORE YOU DIG"

Read the Safety instructions in this Manual.

Keep clear of the auger at all times (4m minimum).

TRENCHER OPERATING INSTRUCTIONS

FITTING A TRENCHER

Drive the Loader to the attachment and couple the Attachment Plate onto the attachment. Raise the Trencher slightly and engage the locking pins fully. Turn the engine off and push the AUX Control Lever forwards and backwards to release any hydraulic line pressure. Clean the hydraulic fittings (QRCs) and then connect them to connections A & C (see "Hydraulics General Description" section).

Removal procedure is the reverse order of the above. Remember to always reconnect the attachment hoses into one another to stop dirt entering the hydraulic system, or fit the dust caps supplied.

PRE-OPERATION CHECK

Ensure that the Trencher is securely attached to the Kanga Loader. Check that the couplings are engaged and check all joints for leaks. Tighten/repair as required. Inspect the cutting teeth, ensuring that they are in good condition and firmly attached.

Chain Tensioning:

The Trencher chain requires 35-45mm of "lift" to have the correct tension and should be adjust as required. This is achieved by loosening the 16mm bolt, adjusting the adjustment wedge, and retightening the bolt.

OPERATING INSTRUCTIONS

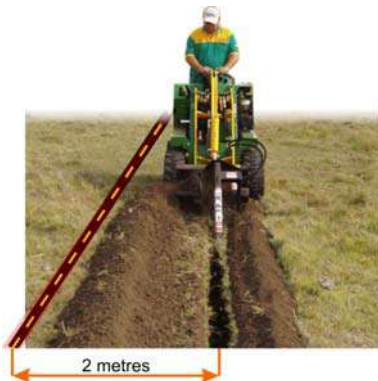

CAUTION: Read all safety rules before operating. See Safety chapter in this manual.

Position the Trencher, and activate the AUX lever so that the chain runs along the top of the boom and returns back towards you on the underside. Engage the TILT lever so that the boom and chain arcs down to dig a trench. When the desired depth is achieved, slowly drive the Kanga Loader backwards along the trench line.

SETTING THE TRENCHING VALVE

(LH side of the Loader). This is a load-sensing valve, which can be set to automatically regulate the speed of travel when trenching.

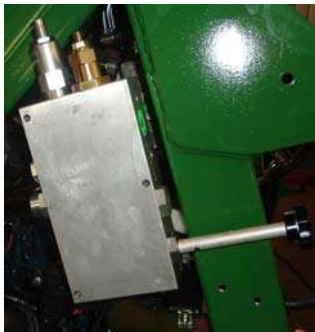

Use the black knob to shut off the valve (turn clockwise). With the trencher cutting to the required depth start moving backwards using the drive levers, open the valve (1/2 a turn) and this will regulate the travel speed. Further adjustment of this valve will vary the cutting speed to suit the conditions and the operator's experience.

NOTE: Minor adjustments are required to maintain a straight line as the Loader will tend to "drift" to the left.



CAUTION: Prior to commencing any trenching operations, check with the Local Authorities and the land owner that there are no buried services (Power, phone, water, gas, sewage etc) in the vicinity.

Australia ONLY: Phone 1100 "DIAL BEFORE YOU DIG"

Read the Safety instructions in this Manual.

Keep clear of the Trencher at all times (4m minimum).



warranty

WARRANTY: 1 YEAR OR 1,000 HOURS

TERMS AND CONDITIONS

1 Year or 1,000 Hour Warranty:

Kanga Loaders hereby warrants to the original purchaser that all Kanga products will be free from defects in materials and workmanship for a period of **one (1) year from the date of purchase or 1,000 hours**, whichever comes first.

Kanga Loaders will repair or replace, any part found upon examination by **Kanga Loaders** to be defective. Such repair or replacement will be free of charge to the purchaser (labour and parts), except as noted below.

This warranty is subject to the following exceptions, conditions, and limitations:

Purchaser's Responsibilities:

- The purchaser must ensure maintenance & minor adjustments, as detailed in the Operator's Manual and engine manufacturer's Manual, are carried out as per the schedule. If there is a discrepancy between the two, the Service Chart in the Operator's Manual will take precedence.
- The purchaser must notify **Kanga Loaders** or an authorized **Kanga Loader** service representative of the need for warranty repair.
- The purchaser must organise, and is financially responsible for the transport of the product to and from the place of warranty repair.

Product Registration:

The **Purchaser** must fill out and return the warranty registration card within 30 days of purchase in order to validate the warranty.

Repairs

Warranty repairs must be carried out by an **authorized Kanga Dealer**.
(For details contact Kanga Loaders on 07 5546 6399).

Battery Warranty- Pro rata

- One to three months - Free replacement
- Four to twelve months - Pro rata over 12 months

Exclusions (No Warranty):

- Normal maintenance, servicing, and replacement items such as spark plugs, oil, oil filters, air filter, muffler, tyres, cutting blades and edges, chains, tracks, cables, etc. are not covered by this warranty.
- Any equipment which has been altered, misused, incorrectly assembled, improperly adjusted, neglected, or damaged by accident is not covered by this warranty.
- Service completed by someone other than an authorized **Kanga Loader** dealer is not covered by this warranty.
- Any attachment not approved by **Kanga Loader** or any parts that are not genuine **Kanga Loader** service parts are not covered by this warranty.
- Engines and engine accessories are covered under the terms of the warranty made by the engine manufacturer, and are not covered by this warranty.

The standard engine manufacturers warranty is for 2 years and is subject to their terms and conditions.



Kanga Loaders may from time to time change the design of its products. Nothing contained in this warranty shall be construed as obligating **Kanga Loaders** to incorporate such changes into previously manufactured products nor shall such changes be construed as an admission that previous designs were defective.

LIMITATION OF REMEDY AND DAMAGES

Kanga Loaders liability under this express warranty, and under any implied warranty that may exist, is limited to repair or replacement of any defective part. In no event shall **Kanga Loaders** be liable for incidental, special, or consequential damages (including lost profits).

DISCLAIMER OF FURTHER WARRANTY

Kanga Loaders makes no warranty other than what is expressly made in this warranty. If the law provides that an implied warranty of merchantability, or an implied warranty of fitness for a particular purpose, applies to Kanga Loaders, any such implied warranty is limited to the duration of this express warranty.

SPARE PARTS WARRANTY: 6 MONTHS

TERMS AND CONDITIONS

KANGA LOADERS LTD will warrant any part found to be defective within the conditions of normal usage. Breakage or damage to any part caused by abuse or misuse will not be considered. Hydraulic hoses will not be covered by warranty if any signs of external damage are apparent.

Consumables including tyres, tubes and tracks are not covered by warranty.

The warranty period is for **six (6)** months from the delivery date and applies to only genuine spare parts.

This warranty does not cover any labour, freight, incidental or consequential charges.

The warranty claim will not be recognised without the return of the faulty part to Kanga Loaders Ltd and must include the Loader and attachment serial number.

A warranty claim for any engine part is covered by the engine manufactures standard warranty contained in the engine manual handbook.

It is the owner's responsibility to ensure that the correct hydraulic and engine oil levels are maintained and that maintenance is carried out as required in the manuals. Claims for damage as a result of insufficient oil levels will not be recognised.



appendices

FIVE STEPS TO EFFECTIVE JSEA

- 1. Document the Activity**
Assemble those involved in the activity and then, using the JSEA worksheet, write down in step by step form, the tasks that make up the activity.
- 2. Identify the Hazards**
Next to each task, identify what part of the task may cause injury to those engaged in the task or others in the vicinity.
- 3. Document the Control Measures**
For each identified hazard, assess the associated level of risk to those involved, and then list the control measures required to eliminate or minimise those risks.
- 4. Identify Who is Responsible**
Document the name of the person responsible for implementing the control measure
- 5. Monitor and Review**
Ensure that the activity is supervised and that the documented process is being followed. The documentation should be reviewed whenever a documented activity changes or when there is a change of personnel or after an appropriate length of time.



JOB SAFETY AND ENVIRONMENTAL ANALYSIS WORKSHEET

JOB SAFETY AND ENVIRONMENTAL ANALYSIS(JSEA) WORKSHEET														
PROJECT/AREA										SITE NAME:				
Workplace/Area					This JSEA Covers:					JSEA No:				
JSEA Team (Attach separate sheet if required):										Reviewed By:			Date:	
Isolation Plan Ref:										Authorised By:			Date:	
Type of Permit/Licence/Plan Required														
	Yes	No		Yes	No		Yes	No		Yes	No		Yes	No
None			Penetration			Gas			Gas Test Required			Solid/Lucid Waste		
Hot Work			Excavation			Isolation			Explosives]			Lifting Analysis		
Cold Work			Confined Space			Electric Isolation			Air/Water Emissions			Traffic Control Permit		
Engineering			Heights			High Voltage			High Pressure Water			Complex Isolations (plan required)		
PPE Requirements (Additional to standard site PPE requirements)												SMP Requirements		
	Yes	No		Yes	No		Yes	No		Yes	No		Yes	No
Chemical Goggles			Respirator (P1/P2 Mask)			Barricading/signs/ Witches Hats			Chipper Screens			Emergency Response Plans		
Face Shield			Safety Helmet			Fire Blankets/ Spark Containment			Electrical Safety(eg gloves & live line rescue)			Plant & Equipment Condition		
Respirator (full face/half face)			Gloves			Extinguishers/ Charged Fire Hoses			Material Safety Data Sheets (MSDS)			Task Specific Training/Induction		
Other:														
<i>Ensure prior to the commencement of operations this area is reviewed by all personnel for any inclusions to the required PPE for the job.</i>														
Potential Environmental Hazards						Hazardous Materials/Substances				Fire/Emergency Equipment Requirements				
<small>(This item requires continual review to include the specific area or activity requirements)</small>						<small>(List any hazardous material/substances to be used or that may affect operations - reference chemwatch I.D.'s)</small>				<small>(Consider fire extinguishers, rescue equipment etc)</small>				
	Yes	No		Yes	No		Yes	No		Yes	No		Yes	No
Air Pollution (dust,fumes)			Spills to ground											
Noise (plant & equipment)			Soil Erosion											
Spills to Drains/Waterways			Hazard to Flora or Fauna											
Details of special precautions to be taken:														



RISK RANKING CHART		LIKELIHOOD TO OCCUR					Risk Ranking	Action Required
		Probable	Occasional	Possible	Remote	Very Unlikely		
CONSEQUENCES								
Severity	Personal Injury							
Extreme	Fatalities						Implement immediate Risk-Control action measures e.g. cease activity, make job / area safe, seek advice and guidance from qualified persons	
Severe	Permanent injury or health issue (eg, loss of limb)						Plan and implement risk control action measures – seek advice from Kanga if in doubt about any aspect of the hazard / risk	
Serious	Loss of time from work or major Doctor or Hospital Treatment						No immediate action, assess overall risk in line with available resources – contact Kanga if in doubt about any aspect of the hazard / risk	
Significant	Minor injury - treatment by Doctor							
Minor	Near miss with minor potential consequences or first aid injury							
STEP No.	JOB STEP	POTENTIAL HAZARD		Consequence		Risk Rank	REQUIRED HAZARD CONTROL	RESPONSIBILITY
		Against each step list the potential risk hazards that could cause injury/damage when the task is performed		Probability				
	List steps required to perform the task in the sequence they are carried out (take photographs of steps and append to this document)					H, M, L		Nominate the person required to action the control measures