



## FOREWORD

Congratulations, and welcome to the fabulous world of **HX9010/1001/1151/1201** ownership, where serious work is made fun again!

This versatile tractor is a culmination of the entire tractor and diesel knowledge gained by the **Daedong IND. Co., LTD** over the years since 1947 and has been designed with the finest materials and under rigid quality control standards set forth by the **KIOTI** Engineering Department.

Knowledge of tractor operation is essential for many years of dependable service and reliability. To help new owner's familiarize themselves with the **KIOTI HX9010/1001/1151/1201**, it is the policy of **KIOTI** tractor to provide an owner's manual which includes helpful information about tractor safety, operation and maintenance. If the information you seek is not found in this manual, your **KIOTI** tractor dealer will be happy to help you.

Please feel free to contact **DAEDONG IND. CO.,LTD / DAEDONG-USA, INC.** with your questions/concerns.

### < NOTE >

- Make sure to read this manual carefully and keep it handy for future reference.
- When leasing or transferring this tractor, deliver this manual together with the tractor.
- The specifications in this manual are subject to change without notice.



## ISO 3600 EU STANDARDS

This manual was compiled in compliance with the ISO 3600, standards and the instructions contained here comply with the requirements of the Machinery Directive 2010/52/EU in force in the European Community. For tractors sold or used outside the European Community, local laws will prevail.

Main protections on the tractors discussed in this manual.

DESCRIPTION	NON CABIN	CABIN
1. ROPS (Protection against overturning)	Yes	Yes
2. FOPS (Protection against objects falling from above)	No	Yes
3. OPS (Protection against penetration of objects from sides) protection against hazardous chemicals	No (Category I )	No (Category I )



## TABLE OF CONTENTS

*SECTION*

■ <b>SAFETY PRECAUTIONS .....</b>	<b>1</b>
■ <b>IDENTIFICATION &amp; INTRODUCTION OF WARRANTY .....</b>	<b>2</b>
■ <b>SPECIFICATIONS.....</b>	<b>3</b>
■ <b>DESCRIPTION OF OPERATING SYSTEM.....</b>	<b>4</b>
■ <b>OPERATION .....</b>	<b>5</b>
■ <b>3-POINT HITCH IMPLEMENT AND LOADER OPERATION .....</b>	<b>6</b>
■ <b>MAINTENANCE.....</b>	<b>7</b>
■ <b>STORAGE AND DISPOSAL.....</b>	<b>8</b>
■ <b>TROUBLESHOOTING.....</b>	<b>9</b>
■ <b>INDEX.....</b>	<b>10</b>



# TABLE OF CONTENTS

<b>SAFETY PRECAUTIONS .....</b>	<b>1-1</b>	DECALS.....	1-29
<b>PRECAUTIONS BEFORE OPERATION .....</b>	<b>1-2</b>	CAUTIONS FOR DECAL MAINTENANCE .....	1-34
GENERAL PRECAUTIONS .....	1-2	<b>IDENTIFICATION &amp; INTRODUCTION OF</b>	
RISK OF OVERTURNING.....	1-6	<b>WARRANTY .....</b>	<b>2-1</b>
<b>PRECAUTIONS DURING OPERATION.....</b>	<b>1-9</b>	<b>VEHICLE IDENTIFICATION NUMBER .....</b>	<b>2-2</b>
WHEN STARTING THE ENGINE .....	1-9	TRACTOR SERIAL NUMBER.....	2-2
WHEN DRIVING THE TRACTOR.....	1-13	ENGINE SERIAL NUMBER .....	2-2
WHEN PARKING THE TRACTOR.....	1-15	<b>ESSENTIAL REPLACEMENT PART .....</b>	<b>2-4</b>
WHEN OPERATING THE P.T.O.....	1-15	OILS AND FLUIDS.....	2-4
WHEN USING THE 3-POINT HITCH .....	1-16	FILTERS .....	2-4
<b>SAFETY PRECAUTIONS DURING SERVICING..</b>	<b>1-17</b>	BELTS AND RUBBER PARTS .....	2-5
<b>SAFETY PRECAUTIONS WHEN USING THE</b>		OTHER COMPONENTS .....	2-5
<b>LOADER .....</b>	<b>1-20</b>	<b>WARRANTY .....</b>	<b>2-6</b>
<b>IMPLEMENTS AND ATTACHMENTS .....</b>	<b>1-23</b>	<b>SPECIFICATIONS.....</b>	<b>3-1</b>
<b>CLEANING THE TRACTOR.....</b>	<b>1-26</b>	<b>GENERAL SPECIFICATIONS .....</b>	<b>3-2</b>
<b>SAFETY DECAL MAINTENANCE.....</b>	<b>1-27</b>	EXTERNAL DIMENSIONS.....	3-2
DECAL MOUNTING LOCATION .....	1-27	GENERAL SPECIFICATIONS .....	3-3
		NOISE LEVELS AS PERCEIVED BY THE OPER-	
		ATOR .....	3-6



# TABLE OF CONTENTS

<p>VIBRATION LEVELS OF THE TRACTOR EXPOSITION TO VIBRATIONS..... 3-6</p> <p><b>TRAVELING SPEED ..... 3-8</b></p> <p><b>IMPLEMENT LIMITATIONS ..... 3-10</b></p> <p style="padding-left: 20px;">STANDARD SIZE BY IMPLEMENT..... 3-10</p> <p><b>DESCRIPTION OF OPERATING SYSTEM ..... 4-1</b></p> <p><b>EXTERIOR VIEW ..... 4-4</b></p> <p><b>SWITCH..... 4-5</b></p> <p style="padding-left: 20px;">MOUNTING LOCATION ..... 4-5</p> <p style="padding-left: 20px;">KEY SWITCH ..... 4-6</p> <p style="padding-left: 20px;">COMBINATION SWITCH ..... 4-7</p> <p style="padding-left: 20px;">HAZARD LAMP SWITCH ..... 4-9</p> <p style="padding-left: 20px;">PTO CRUISE ON/OFF SWITCH ..... 4-10</p> <p style="padding-left: 20px;">PTO RESTART/SETTING SWITCH ..... 4-10</p> <p style="padding-left: 20px;">POWER BOOST FUNCTION..... 4-11</p> <p style="padding-left: 20px;">DPF REGENERATION SWITCH ..... 4-11</p> <p style="padding-left: 20px;">ECO/MODE SELECTION SWITCH..... 4-13</p> <p><b>INSTRUMENT PANEL ..... 4-14</b></p>	<p>TACHOMETER / HOUR METER ..... 4-15</p> <p>PTO SPEED MARK ..... 4-15</p> <p>FUEL GAUGE..... 4-15</p> <p>ENGINE COOLANT TEMPERATURE GAUGE ..... 4-16</p> <p>ENGINE OIL PRESSURE WARNING LAMP ..... 4-17</p> <p>BATTERY CHARGING LAMP ..... 4-17</p> <p>HEAD LIGHT HIGH BEAM LAMP..... 4-18</p> <p>TURN SIGNAL LAMP ..... 4-18</p> <p>GLOW PLUG LAMP..... 4-18</p> <p>PARKING BRAKE LAMP ..... 4-19</p> <p>PTO LAMP ..... 4-19</p> <p>4WD LAMP ..... 4-19</p> <p>QUICK-TURN LAMP ..... 4-20</p> <p>AUTO DRAFT LAMP ..... 4-20</p> <p>BRAKE(ONE SIDE) LAMP ..... 4-21</p> <p>CRUISE PTO LAMP ..... 4-21</p> <p>DPF REGENERATION WARNING LAMP ..... 4-22</p> <p>DPF REGENERATION UNDERWAY LAMP ..... 4-22</p> <p>ENGINE CHECK WARNING LAMP..... 4-24</p> <p>LOW UREA LEVEL WARNING LAMP ..... 4-24</p> <p>WATER-IN-FUEL WARNING LAMP ..... 4-25</p> <p>LOW FUEL LEVEL WARNING LAMP ..... 4-25</p>
---	---



# TABLE OF CONTENTS

EMISSION WARNING LAMP .....	4-26	CALIBRATION BUTTON .....	4-42
ERROR INDICATOR.....	4-26	BEACON LIGHT BUTTON (IF EQUIPPED).....	4-42
<b>OPERATING THE CONTROLS .....</b>	<b>4-28</b>	DEFROST BUTTON .....	4-43
SHUTTLE SHIFT LEVER .....	4-29	IMPLEMENT ADJUSTMENT CONTROLLER.....	4-44
MAIN SHIFT LEVER.....	4-30	ADJUSTING THE IMPLEMENT OPERATION CON- TROLLER HEIGHT.....	4-45
RANGE GEAR SHIFT LEVER .....	4-31	IMPLEMENT ADJUSTMENT SWITCH.....	4-45
PTO SHIFT LEVER.....	4-32	DIFFERENTIAL LOCK PEDAL (REAR) .....	4-48
PTO SELECTION LEVER .....	4-33	SEAT ADJUSTMENT .....	4-48
CLUTCH PEDAL .....	4-34	JOYSTICK LEVER.....	4-51
BRAKE PEDAL.....	4-34	DOUBLE ACTING LEVER.....	4-53
STEERING WHEEL ADJUSTMENT .....	4-35	<b>CABIN SYSTEM.....</b>	<b>4-54</b>
TELESCOPING FUNCTION .....	4-35	INTERIOR DEVICES.....	4-54
PARKING BRAKE LEVER.....	4-36	EXTERIOR DEVICES.....	4-55
PARKING LOCK LEVER .....	4-36	ENTRANCE .....	4-55
FOOT THROTTLE .....	4-37	UNLOCKING THE DOOR .....	4-56
HAND THROTTLE LEVER.....	4-37	REAR WINDOW.....	4-56
PTO MAIN SWITCH.....	4-38	WORKING LIGHT .....	4-57
PTO AUTO/MANUAL SWITCH .....	4-39	WIPER .....	4-57
REMOTE PTO FUNCTION .....	4-39	ANTENNA.....	4-58
DRIVING SELECTION SWITCH .....	4-40	ROOM LAMP .....	4-59
OPERATION/DRIVING RESPONSE SETTING BUT- TON .....	4-42		



# TABLE OF CONTENTS

ACCESSORY .....	4-59	<b>OPERATING THE TRACTOR .....</b>	<b>5-10</b>
REFRIGERATOR / HEATING CABINET .....	4-61	HOW TO DRIVE .....	5-10
SUNSHADE .....	4-61	PARKING .....	5-14
SUNROOF .....	4-62	TURNING .....	5-15
EMERGENCY HAMMER (ONLY EU MODEL) .....	4-62	DRIVING ON SLOPE .....	5-15
HEATER AND AIR CONDITIONER .....	4-63	THE CAUTIONS WHEN COMING IN AND OUT OF WORK FIELD .....	5-16
7-PIN POWER OUTPUT SOCKET .....	4-67	PRECAUTIONS WHILE DRIVING ON THE ROAD ..	5-16
TIRES, WHEELS AND BALLAST .....	4-68	LOADING INTO AND UNLOADING OUT OF THE TRUCK .....	5-17
INFLATION PRESSURE .....	4-69	PRECAUTIONS WHEN USING POWER STEERING ...	5-17
TREAD .....	4-70	3-POINT HITCH CONTROL SYSTEM .....	5-19
WHEEL TORQUE AND DIRECTION .....	4-73	REMOTE HYDRAULIC .....	5-20
ADDITIONAL WEIGHT (IF EQUIPPED) .....	4-74	CONNECTING AND DISCONNECTING IMPLE- MENT .....	5-22
MASS(ES) AND TIRE(S) .....	4-78	<b>3-POINT HITCH IMPLEMENT AND LOADER OPERATION .....</b>	<b>6-1</b>
<b>OPERATION .....</b>	<b>5-1</b>	<b>REMOVAL AND INSTALLATION OF 3-POINT HITCH IMPLEMENT (WITH PTO SHAFT) .....</b>	<b>6-2</b>
<b>PRE-OPERATION CHECK .....</b>	<b>5-2</b>	<b>OPERATION FOR 3-POINT HITCH IMPLE- MENTS .....</b>	<b>6-8</b>
<b>OPERATING THE ENGINE .....</b>	<b>5-3</b>		
STARTING THE ENGINE .....	5-3		
STOPPING THE ENGINE .....	5-7		
WARMING UP .....	5-8		
JUMP STARTING .....	5-9		



# TABLE OF CONTENTS

ADJUSTMENT OF TOP LINK .....	6-8	HOW TO OPEN THE HOOD .....	7-12
PRECAUTION FOR INSTALLING HOW TO USE TOP LINK HOLES .....	6-9	WALK AROUND INSPECTION .....	7-12
ADJUSTMENT OF STABILIZER .....	6-10	CHECKING AND ADDING FUEL .....	7-13
DRAFT HITCH AND TRAILER .....	6-10	CHECKING TRANSMISSION FLUID LEVEL .....	7-14
PTO & PTO SHIELD GUARD .....	6-12	CHECKING AND ADDING UREA .....	7-15
INSTALLING PTO SHAFT .....	6-12	CHECKING ENGINE OIL LEVEL .....	7-16
HYDRAULIC BRAKE VALVE (IF EQUIPPED) .....	6-13	CHECKING COOLANT LEVEL .....	7-17
<b>HANDLING LOADER .....</b>	<b>6-15</b>	CLEANING GRILL, RADIATOR SCREEN .....	7-18
DRIVING ON SLOPE .....	6-16	CLEANING AIR CONDITIONER CONDENSER .....	7-19
JOYSTICK LEVER .....	6-17	CHECKING BRAKE AND CLUTCH PEDALS .....	7-19
<b>MAINTENANCE .....</b>	<b>7-1</b>	CHECKING GAUGES, METER AND EASY CHECKER .....	7-19
<b>MAINTENANCE CHECK LIST .....</b>	<b>7-4</b>	CHECKING HEAD LIGHT, HAZARD LIGHT ETC. ....	7-19
DAILY CHECK ITEM .....	7-4	CHECKING SEAT BELT AND CABIN .....	7-19
MAINTENANCE SCHEDULE CHART .....	7-5	ADJUSTING FAN BELT TENSION .....	7-20
MAINTENANCE SCHEDULE CHART BY OPER- ATING HOURS .....	7-8	ALLOWABLE TOLERANCE OF FREE PLAY BE- TWEEN LH AND RH BRAKE PEDALS .....	7-20
<b>LUBRICANTS .....</b>	<b>7-10</b>	CHECKING BRAKE PEDALS .....	7-21
<b>DAILY CHECK .....</b>	<b>7-12</b>	CHECKING BRAKE OIL .....	7-21
		BLEEDING BRAKE FLUID LINE .....	7-22
		REMOVING WATER FROM THE FUEL FILTER .....	7-23
		CHECKING AND REPLENISHING UREA TANK .....	7-23





# TABLE OF CONTENTS

<b>EVERY 50 HOURS</b> .....	<b>7-24</b>	<b>EVERY 400 HOURS</b> .....	<b>7-34</b>
LUBRICATING GREASE LOCATIONS .....	7-24	CHANGING FRONT AXLE CASE OIL .....	7-34
CHECKING WHEEL BOLT / NUT TORQUE .....	7-25	REPLACING TRANSMISSION FLUID AND FILTER...	7-35
<b>EVERY 100 HOURS</b> .....	<b>7-25</b>	<b>EVERY 500 HOURS</b> .....	<b>7-36</b>
CLEANING AND REPLACING AIR CLEANER		CHANGING ENGINE OIL AND REPLACING FILTER....	7-36
FILTER .....	7-25	REPLACING FUEL FILTER .....	7-38
CHECKING AIR CONDITIONER HOSE .....	7-26	<b>EVERY 800 HOURS</b> .....	<b>7-39</b>
CHECKING CAB CUSHION RUBBER.....	7-26	REPLACING TRANSMISSION FLUID .....	7-39
CHECKING FUEL LINES .....	7-27	<b>EVERY 1,000 HOURS</b> .....	<b>7-40</b>
BATTERY.....	7-27	<b>EVERY 1 YEARS</b> .....	<b>7-40</b>
BATTERY SWITCH.....	7-28	REPLACING AIR CLEANER PRIMARY ELEMENT..	7-40
ADJUSTING BRAKE PEDAL .....	7-30	REPLACING ENGINE OIL AND FILTER.....	7-41
ADJUSTING AIR CONDITIONER BELT TENSION ..	7-30	<b>EVERY 2 YEARS</b> .....	<b>7-41</b>
CHECKING ENGINE OIL FILTER .....	7-31	FLUSH COOLING SYSTEM AND CHANGING	
ADJUSTING FAN BELT TENSION.....	7-31	COOLANT .....	7-41
<b>EVERY 200 HOURS</b> .....	<b>7-31</b>	ANTIFREEZE .....	7-43
CHECKING RADIATOR HOSE AND CLAMP .....	7-31	REPLACING RADIATOR HOSE AND CLAMP .....	7-43
CHECKING INTAKE AIR LINE.....	7-32	REPLACING POWER STEERING LINE.....	7-43
POWER STEERING LINE.....	7-33	REPLACING FUEL LINE.....	7-43
ADJUSTING TOE-IN.....	7-33		







# TABLE OF CONTENTS

<p>REPLACING INTAKE AIR LINE..... 7-43</p> <p><b>SERVICE AS REQUIRED..... 7-44</b></p> <p style="padding-left: 20px;">DRAINING WATER FROM CLUTCH HOUSING..... 7-44</p> <p style="padding-left: 20px;">REPLACING AIR FILTER..... 7-44</p> <p style="padding-left: 20px;">CHECK AND CLEAN CAB AIR INTAKE FILTER..... 7-45</p> <p style="padding-left: 20px;">CHECKING AND REPLACING WIPER..... 7-47</p> <p style="padding-left: 20px;">REPLACING FUSE..... 7-49</p> <p style="padding-left: 20px;">REPLACING CABIN FUSE..... 7-52</p> <p style="padding-left: 20px;">SLOW BLOW FUSE..... 7-55</p> <p style="padding-left: 20px;">REPLACING BULB..... 7-56</p> <p style="padding-left: 20px;">CHECKING THE REFRIGERANT..... 7-62</p> <p><b>STORAGE AND DISPOSAL..... 8-1</b></p> <p style="padding-left: 20px;"><b>TRACTOR STORAGE..... 8-2</b></p> <p style="padding-left: 40px;">DAILY STORAGE..... 8-2</p> <p style="padding-left: 40px;">LONG-TERM STORAGE..... 8-2</p> <p style="padding-left: 20px;"><b>USING TRACTOR AFTER STORAGE..... 8-3</b></p> <p style="padding-left: 20px;"><b>USAGE AND DISPOSAL..... 8-4</b></p> <p><b>TROUBLESHOOTING..... 9-1</b></p>	<p><b>ENGINE TROUBLESHOOTING..... 9-2</b></p> <p><b>TRACTOR TROUBLESHOOTING..... 9-4</b></p> <p><b>INDEX..... 10-1</b></p>
--	--



## SAFETY AND VEHICLE DAMAGE WARNING

This manual includes information titled as **WARNING**, **CAUTION**, **IMPORTANT** and **NOTE**. These titles indicate the following:

 <b>WARNING</b>	<p>This indicates that a condition may result in harm, serious injury or death to you or other persons if the warning is not heeded. Follow the advice provided with the warning.</p>
 <b>CAUTION</b>	<p>This indicates that a condition may result in damage to your vehicle or its equipment if the caution is not heeded. Follow the advice provided with the caution.</p>
 <b>IMPORTANT</b>	<p>This mark indicates emphasis on notable characteristics of working procedures, and information about technology for easier operation.</p>
 <b>NOTE</b>	<p>This indicates that interesting or helpful information is being provided.</p>



## UNIVERSAL SYMBOLS

Various universal symbols have been used on the instruments and controls of your **KIOTI** tractor.  
Below is a list of the universal symbols and their meanings.

Fuel-level	Headlight-low beam	Preheat
Engine coolant-temperature	Headlight-high beam	QT lamp
Parking brake	Four-wheel drive-on	<b>H</b> H : High travel light
Battery charging condition	Fast	<b>L</b> L : Low travel light
Engine oil-pressure	Slow	Auto draft work light
Turn signal	Creep	Auto level work light
Power take-off clutch control-off position	High range	Auto tilling depth work light
Power take-off clutch control-on position	Middle range	Turn up light
Differential lock	Low range	Back up light
Position control-lowered position	<b>N</b> Neutral position	<b>AUTO</b> Auto switch
Hazard warning lights	Coolant	Single brake light



# SAFETY PRECAUTIONS

- PRECAUTIONS BEFORE OPERATION ..... 1-2**
  - GENERAL PRECAUTIONS .....1-2
  - RISK OF OVERTURNING .....1-6
- PRECAUTIONS DURING OPERATION..... 1-9**
  - WHEN STARTING THE ENGINE.....1-9
  - WHEN DRIVING THE TRACTOR .....1-13
  - WHEN PARKING THE TRACTOR .....1-15
  - WHEN OPERATING THE P.T.O. ....1-15
  - WHEN USING THE 3-POINT HITCH.....1-16
- SAFETY PRECAUTIONS DURING SERVICING ... 1-17**
- SAFETY PRECAUTIONS WHEN USING THE  
LOADER..... 1-20**
- IMPLEMENTS AND ATTACHMENTS..... 1-23**
- CLEANING THE TRACTOR..... 1-26**
- SAFETY DECAL MAINTENANCE..... 1-27**
  - DECAL MOUNTING LOCATION .....1-27
  - DECALS .....1-29
  - CAUTIONS FOR DECAL MAINTENANCE .....1-34

# 1

1



## PRECAUTIONS BEFORE OPERATION

### GENERAL PRECAUTIONS

A careful operator is the best operator. Most accidents can be avoided by observing certain precautions. To help prevent accidents, use these safety precautions, and pay attention to the job at hand. If you can prevent an accident, your time will have been well spent.

The following should never be allowed to operate this machine.

- Those under the influence of alcohol
- Women that are pregnant.
- Those without driver's license
- Those who are fatigued, sick or under the influence of medicine; others who are not qualified for certain reasons to operate this machine

Do not operate the machine with fatigue. Take a rest if necessary.

**Otherwise**, an unexpected accident can occur.

#### NOTE

- Allowable age and qualification of operators should be followed by the related laws of local area where the machines are purchased in.

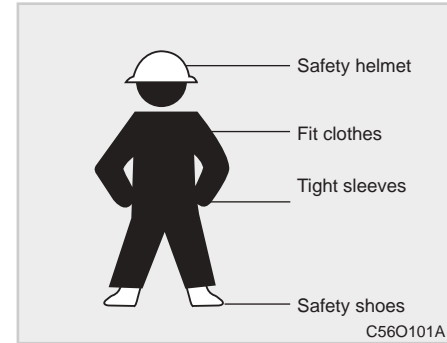

Please wear the appropriate working clothes.

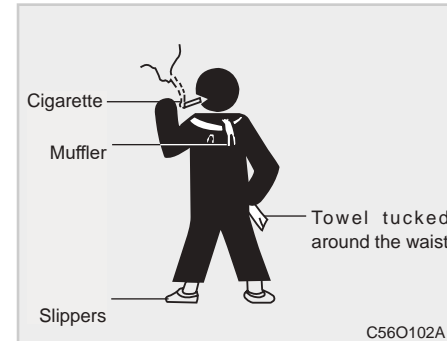

**Otherwise**, your clothes can be caught into rotating parts or you may slip, leading to an accident.



This tractor is basically designed for agricultural use or similar.

Use other than the specified cannot be covered by warranty. The manufacturer is not liable for any damage resulting from unauthorized use, and such action can lead to a dangerous situation to a user. Authorized use means complying with operation, service and repair standards set by the manufacturer.

This tractor should be operated, service and repaired by a well-trained and skilled technician who is also aware of accompanying danger.

It is necessary to follow any applicable accident prevention practices, general health and safety standards and traffic regulations. The manufacturer is not liable for any damage resulting from unauthorized modification.

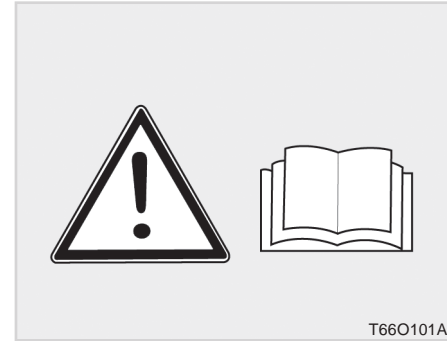

1

1. It is recommended that you read and understand this entire manual before operation of your new tractor. Failure to do so could result in accidents or injury.
2. Only persons who are properly trained should be allowed to operate the tractor.
3. Read and follow all warning labels and decals affixed to the tractor.
4. Replace any missing or damaged decals as soon as it is practical. A list of decals is shown on page 1-27~33.



5. Keep safety decals clean of dirt and debris.
6. Watch where you are going at all times so that you are able to avoid obstacles that can cause injury or damage to your tractor.
7. When starting the tractor make sure your path is clear of people to avoid accidents caused by sudden movements.
8. Before making reverse movements with your tractor, you should always check to see that the path is clear.

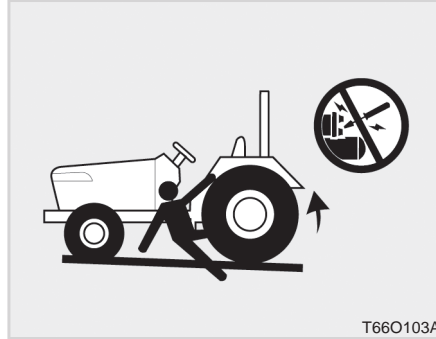

9. Never operate this tractor or any other agricultural equipment while under the influence of alcohol, drugs or while fatigued.
10. While working in cooperation with other tractors always communicate your intentions.
11. Do not start your tractor by shorting across the starter.

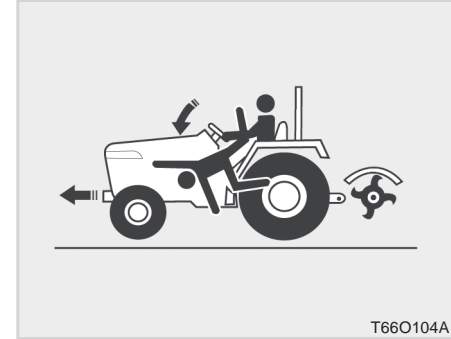

12. Never start the engine while standing on the ground.
13. Only the operator should ride on the tractor unless a passenger seat is installed. Keep bystanders away from the tractor while in operation.
14. When getting on and off the tractor, handholds and step plates should always be used. This will help to prevent accidental slips trips and falls.
15. Be sure to scrape off mud or soil from your shoes before mounting the tractor.



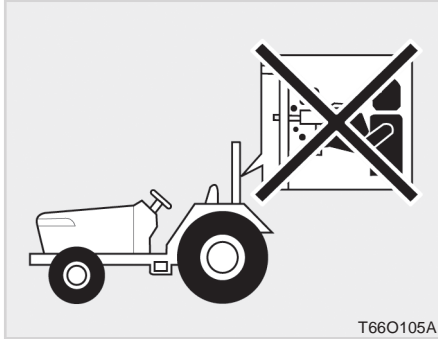

16. All persons using the tractor should have knowledge of its proper operation and should read this manual carefully.
17. Never get off the tractor without setting the parking brake, lowering the implement to the ground and shutting of the tractor.
18. No alterations should be made to your **KIOTI** tractor.

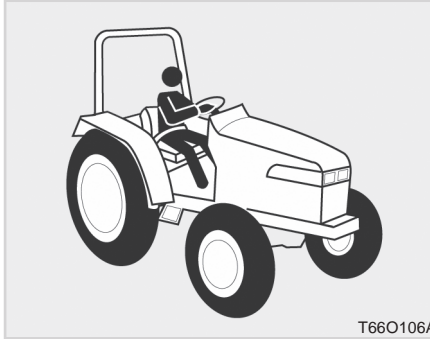

19. Before starting your tractor you should depress the clutch and make sure that all shift levers are in the neutral position and parking brake is applied.

20. For your safety **ROPS** with a seat belt is recommended for all applications.

**NOTE**

- Always use seat belt when the tractor is equipped with a **ROPS** and **CAB**. Never use the seat belt when tractor is not equipped with a **ROPS**. (**ROPS**: Roll-Over Protective Structures)

A **ROPS** and **CAB** should never be modified by welding, grinding or cutting, as this can weaken the **ROPS** structure. If any components of the **ROPS** unit is damaged, it must be replaced.

If the **ROPS** unit is removed or loosened for any reason, the parts should be fitted back to their original positions and all bolts should be properly torqued.

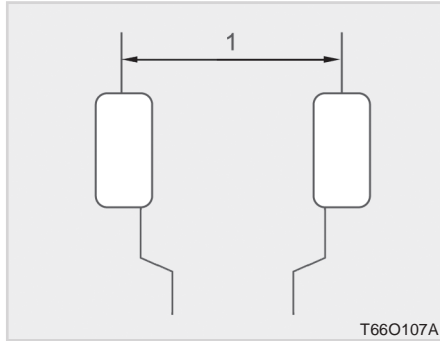

(1) Tread

21. Extra caution should be taken when driving tractors with narrow tread widths. For added stability you should adjust your rear wheel tread width, see page 4-72

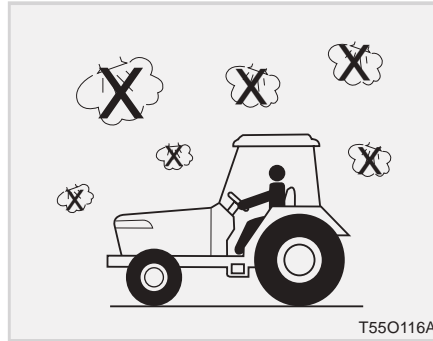

22. This cabin is not certified for chemical proof, never operate the tractor for chemical spray or in the air contaminated by any chemical or equivalent without approved personal safety equip; cartridge respiration/eyeprotection/gloves/ etc.

## RISK OF OVERTURNING

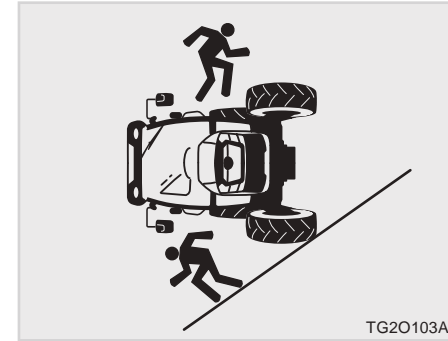

For your safety, tractors must be equipped with original safety belts.

In case of overturning, hold firmly the steering wheel DO NOT try to get off the seat until the tractor has come to a stop. If the doors are locked, leave the tractor through the duly indicated emergency exits.

**⊕ IMPORTANT**

- The safe working practices listed hereunder concerns only a few cases of overturning risk.
- The list is therefore NOT comprehensive of all possible cases.

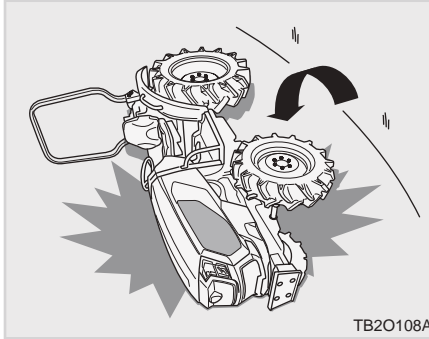

To avoid side overturning:

- Adjust the wheels to the maximum possible track width for the type of work you are doing.
- Lock both brake pedals together before driving on road.
- Reduce your speed according to work conditions. If the tractor is equipped with a front-end loader, carry the bucket and load as low as possible.

- Reduce your speed before making wide turns. DO NOT let the tractor jump or bounce on rough terrains. You could lose control.
- DON'T pull a load too heavy for your tractor. It could run away on the down slope or the tractor could jack-knife around a towed load.
- DON'T brake suddenly. Apply brakes smoothly and gradually.
- When going down a slope use the throttle to slow the tractor engine and use the same gear you would use to up the slope. Shift into gear before you start downhill.
- Engage four-wheel drive (if equipped); this will give greater stability.

**⚠ WARNING**

- **NEVER disengage the clutch or attempt to shift gear after you have started downhill.**

1

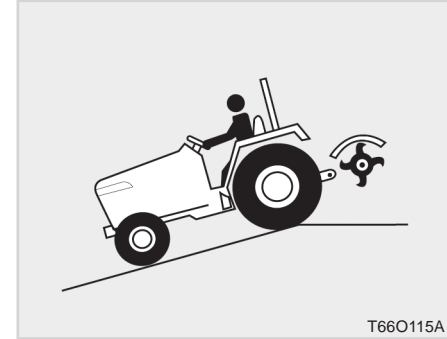
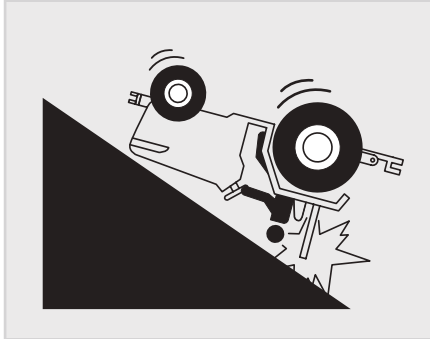
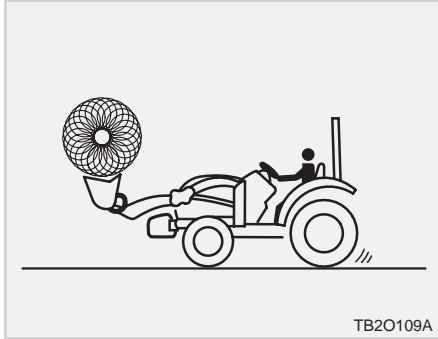

- Always go up and down slopes following a straight upward or downward line.
- Do not put any overloads on a front implement or a trailer. Use suitable counter-weights to keep the tractor stable.
- NEVER use your tractor to round up farm animals.

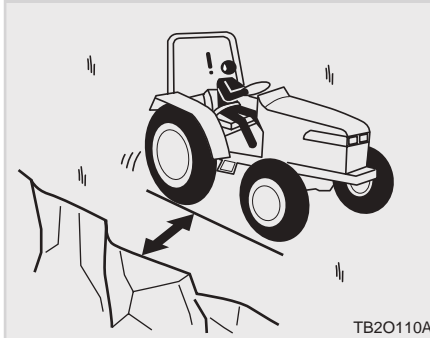

- When operating near ditches and banks, always keep your tractor behind the shear line. Avoid ditches, embankments and river-banks which might cave in.

- If you need cross a steep slope, do not steer uphill, but slow down and take a wide turn. Always drive straight up or down a slope, never across it. When traveling up or down a slope, keep the heavy end of the tractor and the implement pointed uphill.



## PRECAUTIONS DURING OPERATION WHEN STARTING THE ENGINE

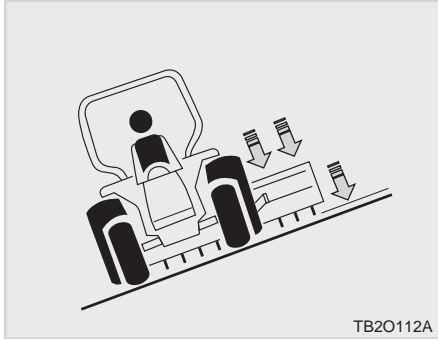

- When driving across a slope with mounted implements, keep such implements on the uphill side. Do not raise implements. Keep them as low and near to the ground as possible.

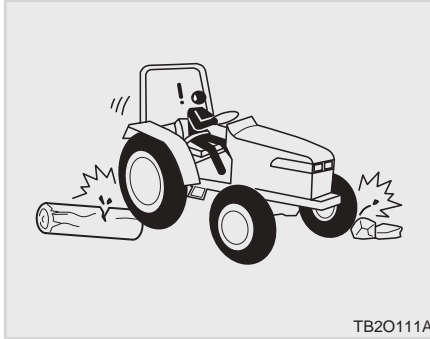

- Avoid crossing steep slopes if possible. If you must do so, avoid any holes or depressions on the downhill side. Avoid any stumps, rocks, bumps or raised areas on the uphill side.

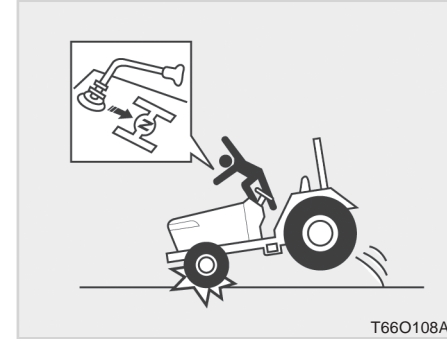

1

1. Avoid accidental contact with gear shift levers while the engine is running. Unexpected tractor movements can result in bodily injury.

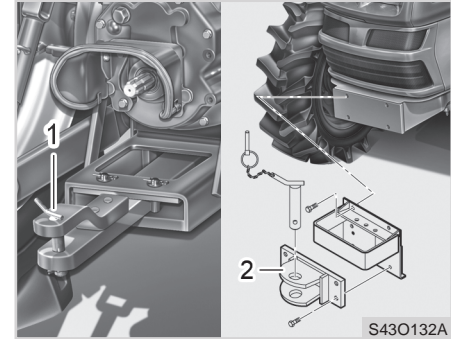
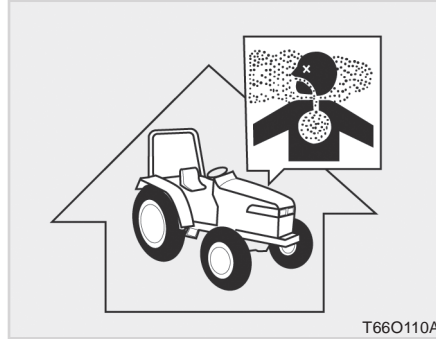

(1) Drawbar

(2) Towing Hook

2. Do not park your tractor on a steep incline, and remember to shut off the engine and P.T.O before dismantling the tractor.

3. Do not operate your tractor in an enclosed building without the proper ventilation. Exhaust containing carbon monoxide can cause serious injury or death.

4. Make sure that all pressure lines are tight before starting the tractor.  
5. Pull only from the draw-bar. Never hitch anything to the axle housing or any other point except the draw-bar. Pulling from any other location only increase the risk of serious personal injury or death.

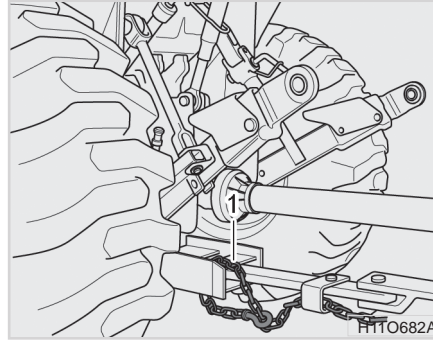
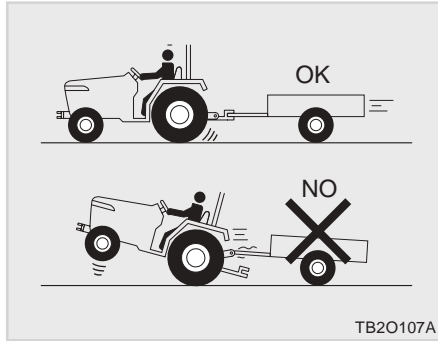

the proper adaptor parts, attach the chain to the tractor draw-bar support or other specified anchor location. Provide only enough slack in the chain to permit turning. See your Dealer for a chain with a strength rating equal to, or greater than the gross weight of the towed machine.

1

6. Improper use of the draw-bar, even if correctly positioned, can cause a rear overturn.
7. Do not overload an attachment or towed equipment. Use proper counterweights to maintain tractor stability. Hitch heavy loads to the draw-bar only.
8. Check for correct coupling between tow hook and trailer. See the Towing Attachments chapter.
9. Use ballast weight as recommended. Never add more ballast to compensate a higher load than allowed. Reduce load for safety.
10. A safety chain will help control drawn equipment should it be accidentally separated from the draw-bar while transporting. Using

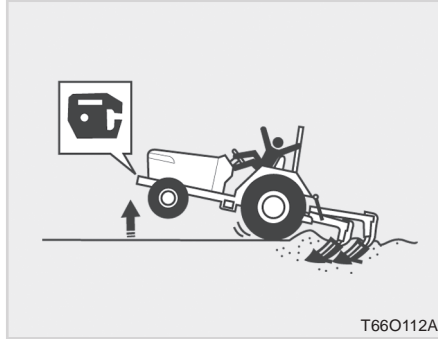

T66O112A

11. If the front of the tractor tends to rise up when heavy implements are attached to the three point hitch, weights should be installed on the tractor. Do not operate the tractor with a light front end.

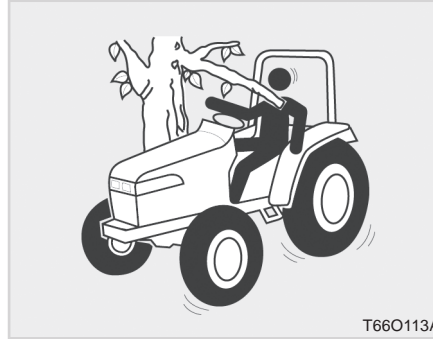

T66O113A

12. Always use the proper ballast weight on your tractor when using rear implements.
13. Watch front and rear to avoid obstacles at row ends, near trees and around other obstructions.

**⚠ WARNING**

- ***Drive carefully to avoid injury from penetration of objects from sides, because this machine does not comply to OPS.***

14. Do not leave equipment in the raised position when the vehicle is stopped or unattended.
15. When using implements or attachments with your tractor you should first read their respective owner's manual. You should always keep their safe operation procedures in mind.
16. You should be familiar with your equipment and its limitations.
17. If abused or used incorrectly your tractor can become dangerous to you and bystanders. Overloading your tractor or using unsafe equipment can also be dangerous and should be avoided. Refer to the "Specifications of Implement Limitation", which outlines the maximum load for safe tractor operation.

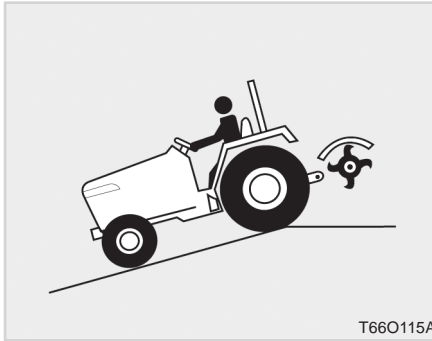
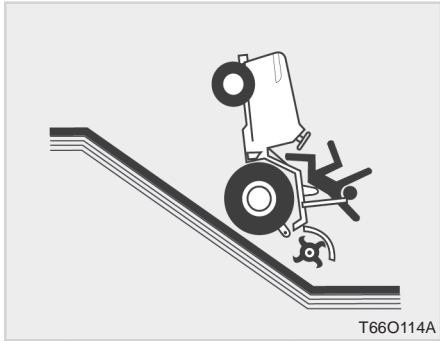
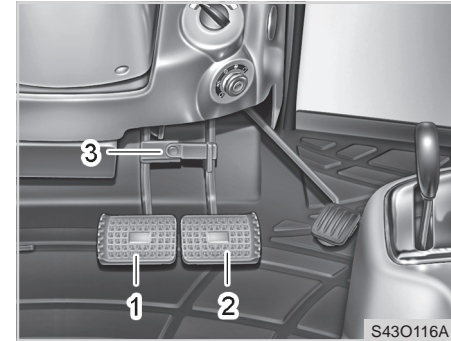

**WHEN DRIVING THE TRACTOR**

(1) Brake Pedal (L) (2) Brake Pedal (R)  
(3) Brake Pedal Lock

18. Driving forward out of a ditch or steep inclines can cause the tractor to tip over backwards. To avoid this you should back out of these positions. Four wheel drive tractors can give you a false sense of security in the tractor's ability to maneuver out of these positions, so extra caution should be taken.
19. Never try to get on or off a moving tractor.

20. When working in groups, always let the others know what you are going to do before you do it.
21. Never "freewheel". Disengaging the clutch or shifting into neutral while descending a slope as this could lead to a loss of control.
22. Do not operate near ditches, holes, embankments, or other terrain features which may collapse under the tractor's weight. The risk of tractor upset is even higher when the ground is loose or wet.

1. Lock the brake pedals together when traveling at road speeds. Brake both wheels simultaneously when making an emergency stop. Uneven braking at road speeds could cause the tractor to tip over.



2. Always slow the tractor before turning. Turning at high speed may tip the tractor over or cause a loss of control.



(1) SMV Emblem

3. Make sure that the Slow Moving Vehicle (SMV) sign is clean and visible. Use hazard lights as required.
4. Observe all local traffic and safety regulations.
5. Turn the headlights on. Dim them when meeting another vehicle.
6. Drive at speeds that allow you to maintain control at all times.
7. Do not apply the differential lock while traveling at road speeds. As the tractor may run out of control.

8. Avoid sudden movements of the steering wheel as this can cause a loss of control of the tractor. This risk is especially great when traveling at road speeds.
9. Do not operate an implement while the tractor is on the road. Lock the three point hitch in the raised position.
10. When towing other equipment, use a safety chain and place an SMV emblem on it as well.

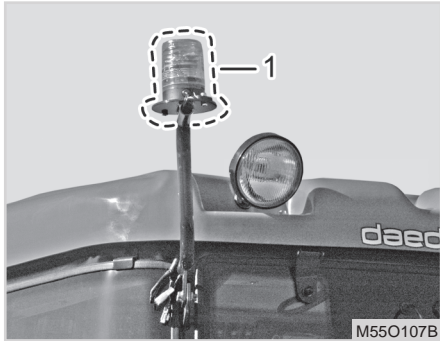
**WHEN PARKING THE TRACTOR WHEN OPERATING THE P.T.O.**

M55O107B

*(1) Low Speed Indicator*

11. When driving the tractor after sunset, be sure to turn on the low speed indicator. (If equipped)  
Otherwise, a collision can occur by poor visibility.

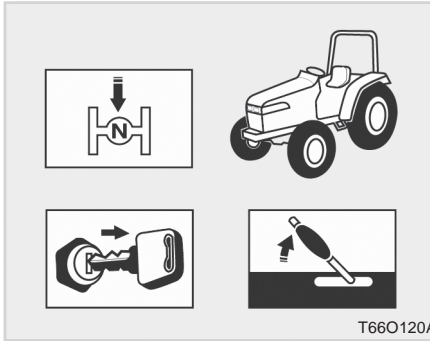

T66O120A

1. Disengage the P.T.O, lower all implements, place all control levers in the neutral position, set the parking brake, stop the engine and remove the key.



S43O120B

*(1) P.T.O Shaft Cover  
(2) P.T.O Shaft Cap*

1. Make sure the tractor is completely stopped, gears are in neutral and all moving components have completely stopped before connecting, disconnecting, adjusting, cleaning or servicing any P.T.O driven equipment.
2. Keep the P.T.O shaft cover in place at all times. Replace the P.T.O shaft cap when the shaft is not in use.

- Before installing or using P.T.O driven equipment, read the manufacturer's manual and review the safety labels attached to the equipment.

**⚠ WARNING**

- **Before driving an implement through the PTO, always make sure that all bystanders are well away from the tractor.**
- **When using the PTO drive with a stationary tractor, always make sure that the gears are in neutral and that the parking brake is applied.**
- **Before starting up any PTO-driven implement hitched to the three-point linkage, lift the implement to its full height and check that at least 1/4 of the total length of the telescopic section of the drive shaft is engaged.**
- **Ensure that implements and attachments are properly installed and that the tractor and implement PTO RPM ratings match.**

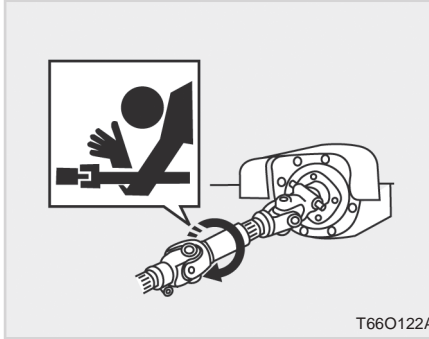

- When operating stationary P.T.O driven equipment, always apply the tractor parking brake and place chocks behind and in front of the rear wheels. Stay clear of all rotating parts.
- Do not attach a PTO driven implement if the implements safety shields are damaged or not in place. Rotating shafts are an entanglement hazard.

**WHEN USING THE 3-POINT HITCH**

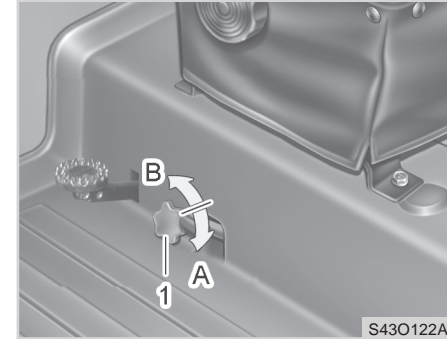

(1) 3-point hitch lowering speed knob  
 (A) "SLOW" (B) "FAST"

- Use the 3-point hitch only with equipment designed for 3-point hitch usage.
- When using a 3-point hitch mounted implement, be sure to install the proper counterbalance weight on the front of the tractor.
- When transporting on the road, set the implement lowering control in the "LOCK" position to hold the implement in the raised position.



## SAFETY PRECAUTIONS DURING SERVICING

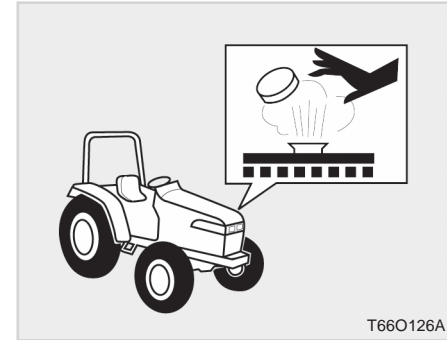

1

In order to service your tractor you must park it on a flat level surface, set the parking brake, place the gear shift lever in neutral and stop the engine.

1. Do not smoke while working around the battery or when refueling your tractor. Keep all sparks and flames away from the battery and fuel tank. The battery presents an explosive hazard because it gives off hydrogen and oxygen etc. especially when recharging.

2. Allow the tractor time to cool off before servicing any part that may have become hot while the tractor was running.

3. You must always stop the engine before refueling the tractor. Avoid overfilling the tractor or spilling the fuel.

4. Before jump starting a dead battery, read and follow all of the instructions. (Refer to the page 5-8)

5. It is recommended to keep a first aid kit and fire extinguisher handy at all times.

6. Do not remove the radiator cap while the coolant is hot. When cool, slowly rotate the cap to the first stop and allow sufficient time for excess pressure to escape. After all the pressure is released remove the cap completely. If your tractor is equipped with a coolant recovery tank, add coolant there rather than to the radiator.

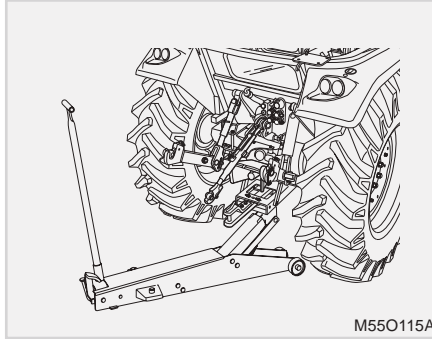
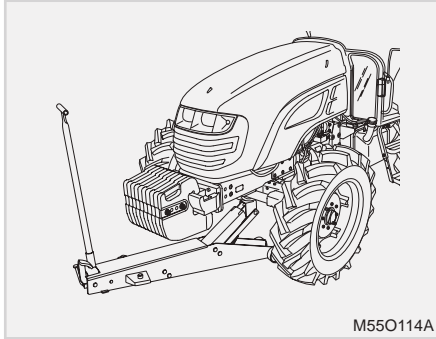

 **NOTE**

- Apply the jack lift to the lifting points according to the type of operation and follow the safety procedures given before.

7. If the tractor must be lifted for servicing, take it to a suitably equipped workshop.
8. Carry out the following operations before any operation about the tractor: Engage the four-wheel drive, the first gear and the parking brake and put chocks to the wheels touching the ground.
9. Before lifting the tractor, avoid its swinging by means of wooden wedges applied to the front axle.
10. Use jack lifts of suitable capacity and apply them at the center of the front and rear axles while paying due attention to weight distribution.
11. No decals for the lifting point are applied on the tractor, as they would be, too difficult to apply in the available spaces and would be all too easily removed or effaced during normal operation of the tractor.

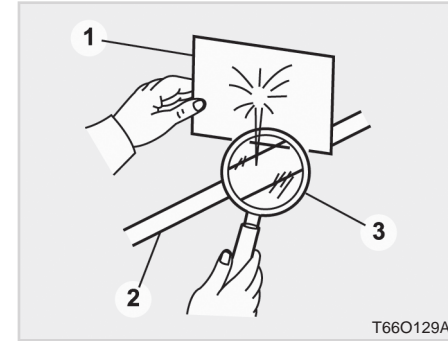
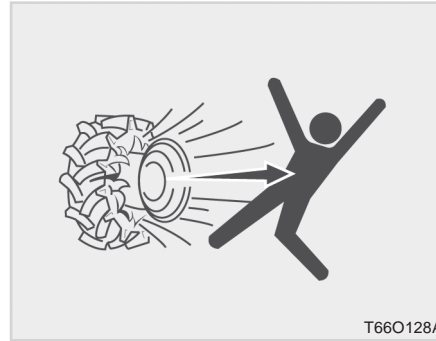
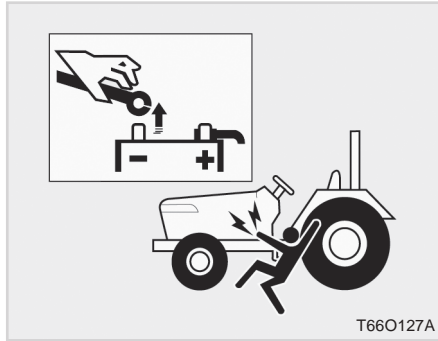

(1) Cardboard (3) Magnifying Glass  
(2) Hydraulic Line

12. When working with your tractors electrical components you must first disconnect the battery cables.
13. To ensure that there are no accidents from sparks you must first disconnect the negative battery cable.

14. Tire mounting should be done by qualified professionals, with the proper equipment.
15. Maintaining correct tire pressure is important for the life of your tires. Do not inflate the tires above the recommended pressure specified in the owner's manual. (See page 4-61)
16. Securely support the tractor when changing wheels or the wheel tread width.

17. Make sure that wheel bolts have been tightened to the specified torque.
18. Escaping hydraulic fluid under pressure has sufficient force to penetrate skin, causing serious personal injury. Be sure to release all residual pressure. Before disconnecting hydraulic lines.  
Before adding pressure to the hydraulic system, make sure that all connections are tight and that all lines, pipes and hoses are free of damage.

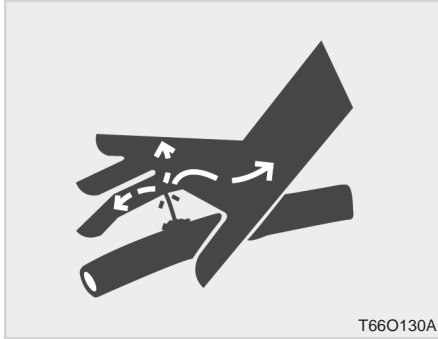

19. Fluid escaping from pinholes may be invisible. Do not use hands to search for suspected leaks;  
Use a piece of cardboard or wood, instead. Use of safety goggles or other eye protection is also highly recommended. If injured by escaping fluid, see a medical doctor at once. This fluid can produce gangrene and/or severe allergic reaction.



20. Keep environmental pollution in mind. When replacing coolant or oil, dispose of it the right way.  
Be sure to observe all relevant regulations when you dispose of the engine oil, transmission oil, fuel, coolant, filters and battery.

## SAFETY PRECAUTIONS WHEN USING THE LOAD- ER

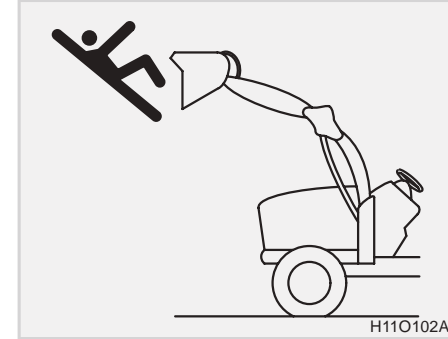

1. Never let anyone get in the loader and use the loader as a workbench. Otherwise, it may lead to a fatal injury or even death.



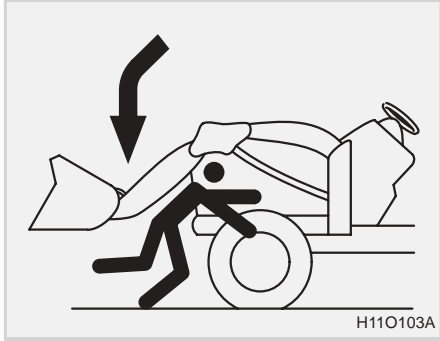

2. Do not stand under the lifted loader or get close to it. Also, lower the loader arm onto the ground before leaving the tractor. Otherwise, it may lead to a fatal injury or even death.

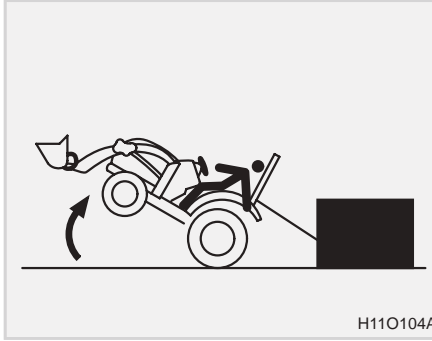

3. The loader can be turned over if a draw-bar is improperly loaded. Make sure to use a draw-bar proper for the 3-point hitch lower link. Otherwise, it may lead to an injury or even death.

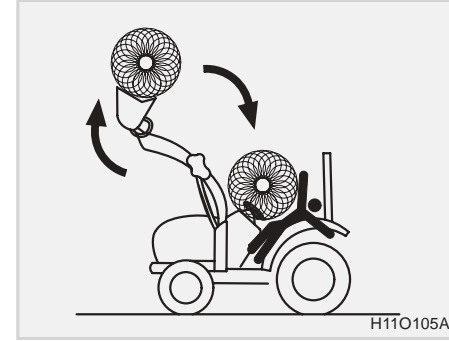

4. Never carry a big object with the loader unless a proper implement is attached. Keep a carried object low during driving. Otherwise, it may lead to an injury or even death.

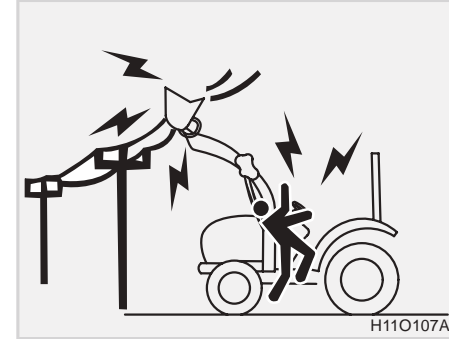

5. When attaching or detaching the loader, fix all parts which are connected to the bucket and boom. The bucket or boom can be accidentally dropped down, leading to an injury or even death.

**⊕ IMPORTANT**

- **ROPS (Roll Over Protective Structure), sun canopy not a FOPS. (Falling Object Protective Structure)**

**It never can protect the riders against falling objects.**

**Avoid driving the vehicle into a dangerous area such as falling rocks zone.**

6. Do not allow loader arms or attachment to contact electrical power lines. Electrocutation will cause serious injury or death.



## IMPLEMENTS AND ATTACHMENTS



7. Keep bystanders away. No riders.

### WARNING

- *Use exclusively front loader approved by the tractor's manufacturer, with CE mark and parallelogram type.*
- *The installation and modification of the tractor must be carried out with the highest technical standards by specialized workshops with qualified personnel. Such workshops must be able to guarantee and attest the risk analysis provided for in the Machinery Directive 2006/42/EC concerning the foreseen and predictable use of the tractor with front loader, in order to carry out all required adaptations of the tractor.*
- *Use the front loader and all supplied equipment as prescribed by the loader's operator manual.*

### IMPORTANT

1. • **Keep the loader's operation manual together with the tractor's manual, always at hand in the storage compartment of the tractor.**
- **Before driving or operation your tractor, it is mandatory to read this manual very carefully, with special attention to the chapter concerning safety rules.**

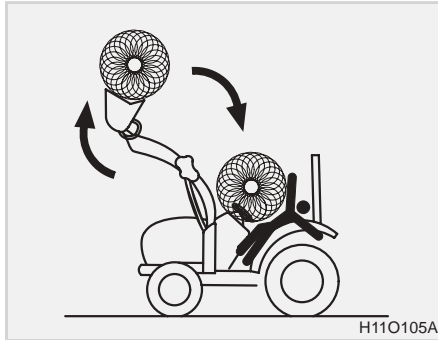

**⚠ WARNING**

- ***Use of the front loader and of the tractor equipped with front loader, if not correctly carried out, and handling not secured loads constitute a serious danger for the operator and everyone standing by, because of the danger of falling objects.***

- Three-point hitch and side mounted implements make a much larger arc when turning than towed equipment. Make certain to maintain enough clearance for safe turning.
- To use mounted, semi-mounted or towed equipment and trailers it is required to use exclusively CE marked implements, after reading their operation handbooks carefully, giving maximum attention to risks connected with their association to the tractor.
- Implements must be hitched to the tractor by means of the three-point linkage. It is therefore necessary to check couplings for compatibility according to their classes.  
The implement has to be fitted with suitable supports in order to avoid tipping or accidental shifting during hitching. Always check three-directional fastening to the tractor of the mounted or semi-mounted implement, to avoid dangerous swinging

and shaking during transport and work that could jeopardize the stability of the tractor implement assembly.

- The cardan shaft must be always CE-marked, provided with suitable guards and suitable to tractor-implement coupling. Follow all directions of the operation manual, concerning both the fastening according to connection direction and safety rules to avoid rotation of protections (chains) and overlaying of the telescopic tubes. Also keep articulation angles.

**⚠ WARNING**

- ***When a tractor with safety frame is equipped with a front loader, there is still a risk if the implement is improperly used. This risk is due to objects falling from above. The operator has no protection against this risk.***



To reduce risks, the following precautions should be used.

- Only use loader equipped with a load self-levelling system, i.e. of the parallelogram type.
- Only use specific implements for the operation to be performed. Strictly follow the directions and warnings in the loader's operation manual.
- Use the machine and the implement with caution, drive on plane ground and avoid pits, excavations and ditches. Do not turn, start or stop abruptly.
- If a front loader is mounted, it is advisable to use a tractor with cab or with a 4-post frame with FOPS safety system. The loader installer should carefully analyze all risks and make all required adjustments.

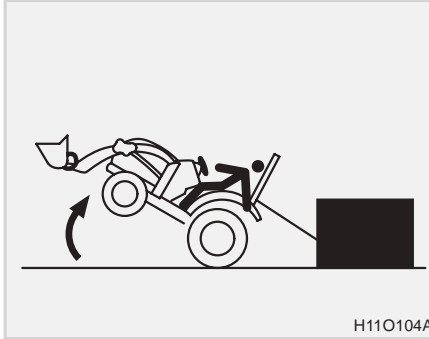

- Hitch loads to the drawbar only. Towing or attaching to other locations may cause the tractor to overturn.
- Improper use of the drawbar, even if correctly positioned, can cause a rear overturn.
- DO NOT overload an attachment or towed equipment. Use proper counterweights to maintain tractor stability. Hitch heavy loads to the drawbar only.
- Check for correct coupling between

tow hook and trailer. See the Towing Attachments section.

- Use ballast weight as recommended. NEVER add more ballast to compensate a higher load than allowed. Reduce load.

1



## CLEANING THE TRACTOR

- Keep work surfaces and engine compartments clean. • Before cleaning the machine, always lower implements to the ground, engage the first gear, engage the parking brake, turn the engine off and remove the key.
- Always use specific personal safety devices for each service operation.
- Clean steps, pedals and floor. Remove grease or oil. Brush away dust or mud. In winter, scrape away snow and ice. Remember - slippery surfaces are dangerous.
- Avoid using petrol, paraffin, paint thinner etc. when cleaning plastic parts, e.g.; console, instrument cluster, monitors and gauges etc. Use ONLY water, mild soap and a soft cloth when you clean these parts. Using petrol, paraffin, paint thinner etc., will cause cracking or deformation of the part being cleaned.
- Remove and put away any tools, buckets, chains and hooks.



# SAFETY DECAL MAINTENANCE DECAL MOUNTING LOCATION

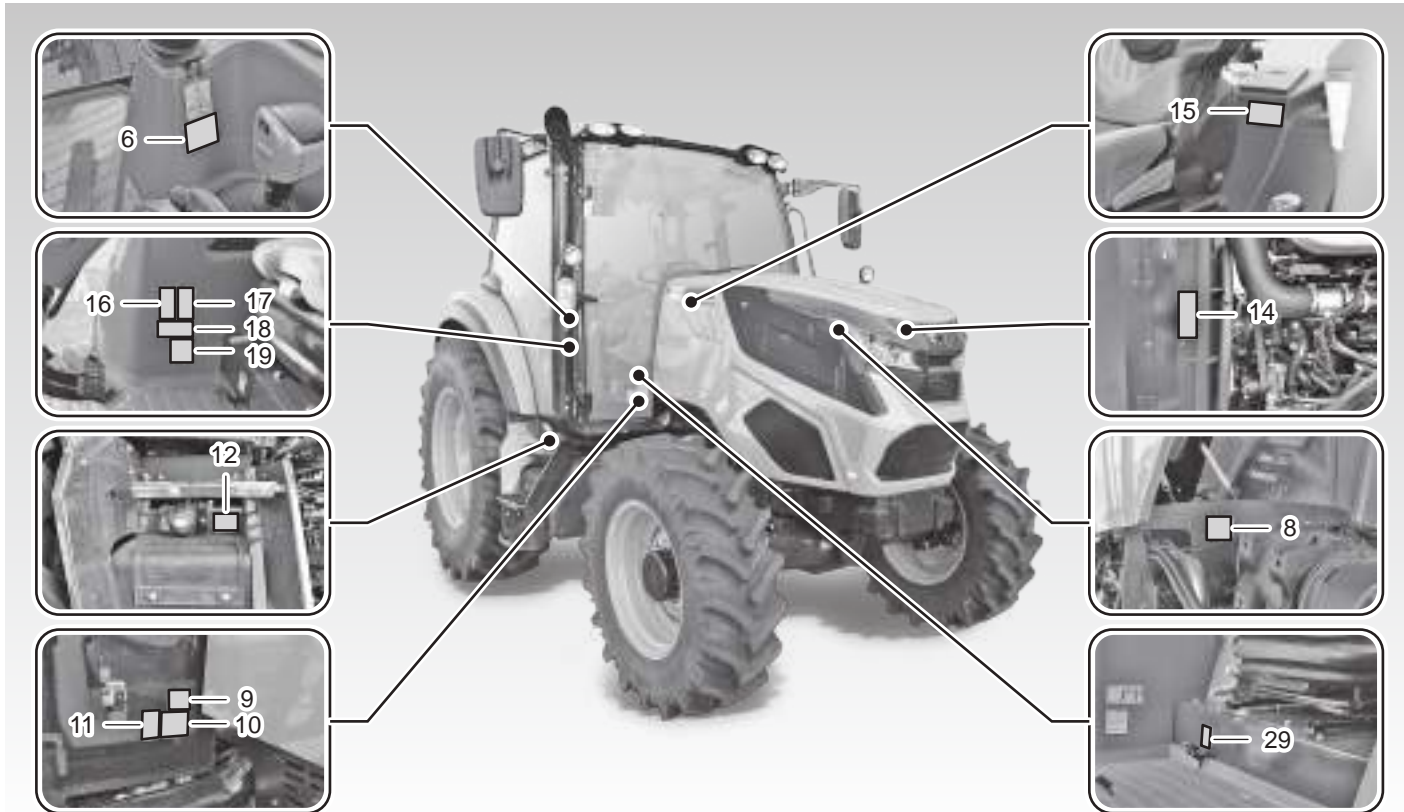

1

HX1O105A

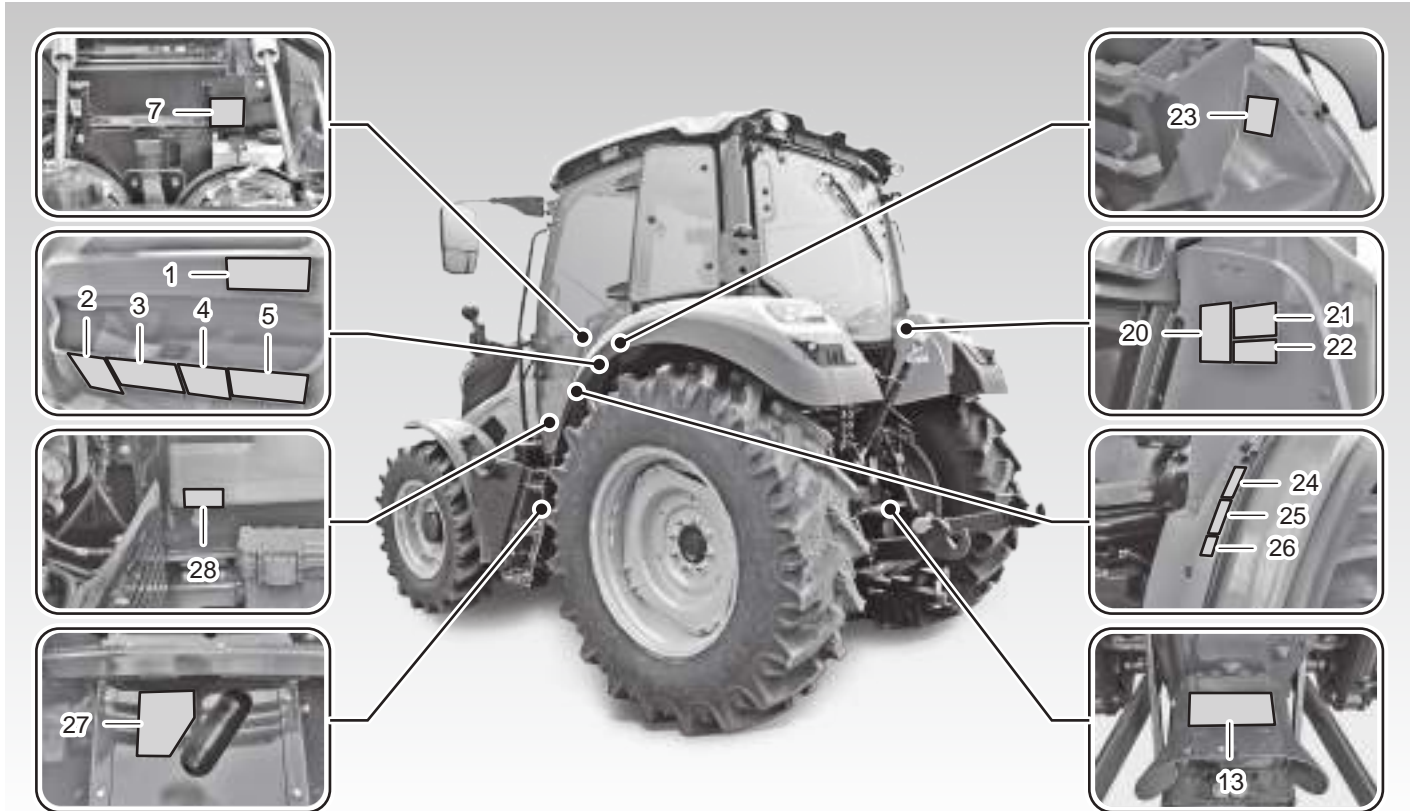

HX1O106A





DECALS

(1) Part No. : T4182-53191

**⚠ WARNING**

TO AVOID POSSIBLE INJURY,  
DEATH OR LOSS OF PROPERTY FROM A MACHINE RUNAWAY

- With the engine off, unexpected machine movement could result regardless of the gearshift position.
- Before dismantling the machine, apply the parking brake to prevent machine runaway.

T4182-53191

(2) Part No. : TG31-0005A

Exhaust gas aftertreatment system (DOC, DPF, SCR) is equipped on this tractor. It is important to use CJ-4 graded engine oil. Otherwise, it will cause the serious failure of the system.

**Regeneration Lamp**

**Passive Regeneration**

1. Lamp turns to on when vehicle in passive regeneration.
2. Do not touch the aftertreatment system during regeneration. It is extremely hot.
3. Keep the distance with people and animal.
4. Keep away flammable objects around the exhaust pipe.
5. Do not turn off the engine when the lamp is on and continue the work above 1700rpm

**Forced Regeneration (Manual Regeneration)**

1. Park the tractor on flat place and keep away flammable objects around the exhaust pipe
2. Procedure
  - 1) Place the parking brake to the brake Position
  - 2) Keep the gear at neutral
  - 3) Put the foot/hand accelerator pedal on "idle"
  - 4) Obtain at least 20°C of engine coolant temperature
  - 5) Push the regeneration switch for 2 seconds
  3. Engine speed varies automatically until the regeneration is finished
  4. Do not manipulate the engine speed by driver's demand
  5. Do not release the parking brake from the brake position
  6. Do not press the clutch pedal
  7. Do not move the gear from neutral position

- Do not turn off the engine right after the heavy work. Wait at idle more than 3minutes to protect aftertreatment system.
- Wait for 2 minutes before disconnecting the battery.
- Fill the Diesel Exhaust Fluid tank when the low DEF lamp is on. It will cause the engine derating and idle lock within the time.

TG31-0005A

(3) Part No. : T2445-50724

**⚠ WARNING ⚠**

TO AVOID PERSONAL INJURY:



1. Roll-Over Protective Structure(ROPS) with a seat belt is recommended in most applications. Check the owner's manual and discuss with your local dealer.
2. Always use the seat belt when the tractor is equipped with ROPS. Never use the seat belt when the tractor is not equipped with ROPS.

T2445-50724

(5) Part No. : T4938-52321

**⚠ WARNING**

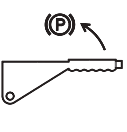

- \* Be sure to pull the parking brake up when parking or stopping.
- \* Pull the brake lever up to set the parking brake.
- \* Push the brake lever down while pushing the button to release the parking brake.

(Caution) Release the parking brake when driving otherwise it would cause early abrasion of brake disk, overheating of transmission and problems in hydraulic part.

T4938-52321

(4) Part No. : T4837-51181

**+** THE MAIN POINT OF SAFETY DRIVING

Keep list for using tractor safe.

**START**

1. Place gearshift lever in neutral position.
2. Lock parking brake.

**DRIVE**

3. Must connect left, right brake pedals.
4. Don't rapidly start, brake, turn.
5. Never carry riders.
6. Don't use differential lock equipment on driving.
7. Don't operate the auxiliary equipment except working.
8. Slow down on turns, rough ground and slopes to avoid upset.

**WORK**

9. Use a stepstone in case of entering a rice field.
10. Keep people off tractor.

**STOP**

11. Stop engine and lock parking brake.
12. Use chock at slope.
13. Down the auxiliary equipment.

**INSPECTION**

14. Stop engine.
15. Be sure to operate in flat and safe place.

T4837-51181

(6) Part No. : TG16-1886A (Only DDTC, EETC)

**⚠ CAUTION**

When driving, do not operate the range shift lever.

(Operating it may damage the transmission.)

TG16-1886A



(7) Part No. : TG16-1477A

**WARNING**

1. Never use car's brake oil.  
 2. Be sure to use only a genuine OIL.  
 (Shell Tellus S2 MX68 or S2 M68)  
 3. When use car's brake oil, occur deadly accident to be caused by fatal damage of all kind of seal.

TG16-1477A

(8) Part No. : T2615-53561

**WARNING**

Do not remove the radiator cap when the engine is running or while the engine is hot. If the radiator cap is removed, hot vapor or liquid may be violently released causing burns.

T4930-92371

(9) Part No. : T2615-55112

**WARNING**

- Do NOT run an engine in an enclosed area.
- Exhaust fumes cause sickness or possible death.
- Do NOT touch a muffler with bare hands.

T4930-52471

(10) Part No. : TG36-1892A

**CAUTION**

1. When working with an implement using external hydraulic pressure, such as a front loader, make sure to check the transmission fluid amount. If insufficient, add fluid to the specified level.  
 2. When stopping the engine, lower the bucket onto the ground in advance.

TS310-52391

(11) Part No. : T4938-53551

**DANGER**

Start only from seat in park or neutral. Starting in gear kills.

T4938-53551

(12) Part No. : TG36-1881A

**CAUTION**

After the engine stopped, wait for two minutes and disconnect the battery switch.

TG36-1881A

(13) Part No. : T2325-50743



(14) Part No. : T4625-52351



(15) Part No. : TG16-0593A



1

(16) Part No. : T4125-56171



(17) Part No. : T4125-56181



(18) Part No. : TG36-1885A



(19) Part No. : T4938-52531

**WARNING**



Disconnect    Connect



Brake Lock

- Always lock the left and right brake pedals together before driving on the road.
- Activating only one brake at higher speeds could cause loss of control.

T4938-52531

(20) Part No. : T4817-52201

**WARNING**



Position lever



Up  
Down

**Precaution for position lever**

- Don't operate except attaching and detaching of implement.
- Place gearshift lever in neutral position and must lock parking brake before operating at a flat.
- PTO switch must be located on the neutral position.
- When operate engine at the high speed, implement quickly move up and down, therefore operate to ensure sufficient safety distance at the low speed.

T4817-52201

(21) Part No. : T5210-52131

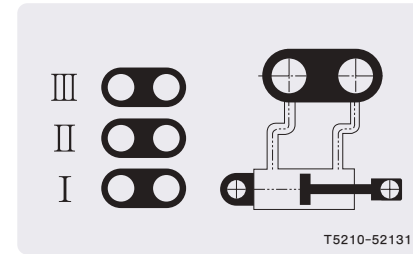

(22) Part No. : TG16-1530



Be sure to use the genuine Daedong / KIOTI oil or equivalent oil specified in owner's manual. Otherwise, this may cause machine failure which may not be covered under warranty.

TG16-1530

(23) Part No. : TG36-1888A

**WARNING**

1. The auxiliary seat is only for training or diagnostic testing.
2. Do not use the auxiliary seat for other passengers (in particular, children).
3. Make sure to wear the seat belt and hold the frame grip on the door.
4. Before starting off the tractor, make sure to take a seat and close the door completely.
5. Take caution not to block the view of the driver or cause risks of interfering with the driver's operation of the levers.
6. Do not make a sudden start of stop of the tractor or make sharp turns.
7. When the seat belt or door lock is not working, do not use the auxiliary seat.
8. Do not use the auxiliary seat for transportation.
9. When opening or closing the door while on the auxiliary seat, move the door slowly.

If ignored, it may causes a death or severe injuries.

TG36-1888

(24) Part No. : T4125-56151

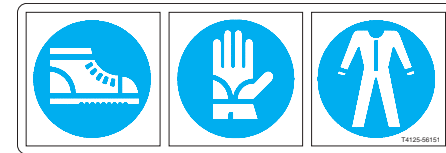

(25) Part No. : TB16-0076A

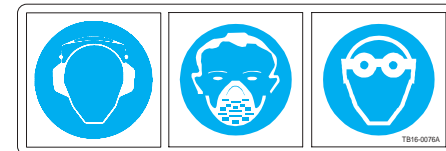



(26) Part No. : TG16-1499A

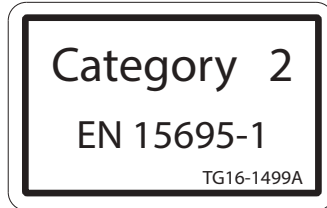

(29) Part No. : T2611-26693

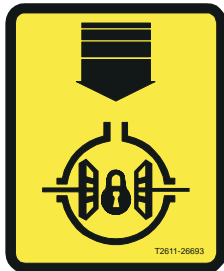

(27) Part No. : TG36-1882A



(28) Part No. : TC26-0388A

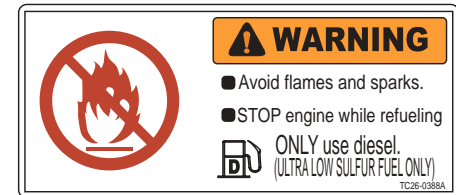

1



## CAUTIONS FOR DECAL MAINTENANCE

Safety decals are attached to the tractor for safe operation. Make sure to follow the instruction on the decals as well as the following instruction.

### CAUTION

- **Keep the decals clean and intact. If any decal is dirty, wash it with soap and dry with a soft cloth.**
- **Never use a solvent, such as thinner or acetone, since it can ruin the decals.**
- **Do not spray high-pressure water directly onto the decal. The decal may fall off the tractor.**

### IMPORTANT

- **If a decal is damaged or lost, contact your local KIOTI dealer immediately to install a new decal.**
- **Make sure to attach the decal to the correct position cleanly without bubbles after cleaning its mounting surface.**
- **If a decal is attached to a component to be replaced, replace the decal as well.**



## IDENTIFICATION & INTRODUCTION OF WARRANTY

<b>VEHICLE IDENTIFICATION NUMBER .....</b>	<b>2-2</b>
TRACTOR SERIAL NUMBER.....	2-2
ENGINE SERIAL NUMBER .....	2-2
<b>ESSENTIAL REPLACEMENT PART .....</b>	<b>2-4</b>
OILS AND FLUIDS.....	2-4
FILTERS .....	2-4
BELTS AND RUBBER PARTS .....	2-5
OTHER COMPONENTS .....	2-5
<b>WARRANTY.....</b>	<b>2-6</b>

# 2

2



## VEHICLE IDENTIFICATION NUMBER TRACTOR SERIAL NUMBER      ENGINE SERIAL NUMBER



(1) Tractor Serial Number Plate

This number is to identify the vehicle, and its plate is attached on the front right side of the front axle frame.



(1) Engine Serial Number

The engine number is stamped on the cylinder block near the high-pressure pump in the right side of the tractor. Also, it is stamped on the decal on the back of the turbocharger in the left side of the tractor.

Your dealer is interested in your new tractor and has the desire to help you get the most value from it. After reading this manual thoroughly, you will find that you can do some of the regular maintenance yourself.

However, when in need of parts, warranty or major service, be sure to see your **KIOTI** dealer. For service, contact the **KIOTI** dealership from which you purchased your tractor or your local authorized **KIOTI** dealer.

When in need of parts, be prepared to give your dealer both the tractor and engine serial numbers.

Before using non-**KIOTI** approved implements, contact your nearest dealer, regarding safety application of the implement.





• **Tractor Model Name :**

• **Tractor Serial No :**

• **Engine Serial No :**

• **Date of Purchase :**

To be filled in by purchaser.

## ESSENTIAL REPLACEMENT PART OILS AND FLUIDS



Various oils and fluids are used in this tractor for operation, lubrication, cooling, and anti-corrosion of various parts. If oil or fluid is insufficient, contaminated or degraded, it can cause poor performance, incorrect operation, and seized part of the tractor, leading to malfunction.

Regularly add or change the fluid specified on the right to keep the tractor in perfect condition.

No.	ITEM	SPECIFICATION	CAPA [U.S.gal.(L)]
1	Engine oil	API CJ4 SAE 10W30	3.9 (15)
2	Urea solution	Urea solution approved by Ministry of Environment (according to ISO 22241)	4.7 (18)
3	Transmission fluid	DAEDONG : S-UTF 38 Exxonmobil : Mobilfluid 350 BP : AUTRAN SYN 29 Shell : Donax-TD Low vis Petro-Canada : Duratran XL Synthetic Blend	20.34 (77)
4	Grease	SAE multi purpose type grease	A little
5	Antifreeze	Fresh clean water with ethylene glycol (50 : 50)	HX9010/1001: 4.6 (17.4) HX1151/1201: 4.7 (18.0)

## FILTERS

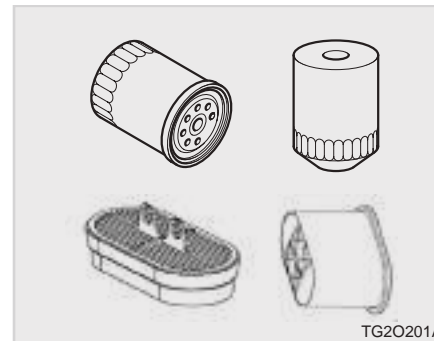

Filters for the engine, transmission, air cleaner, and A/C are consumables that purify oil and air. Make sure to replace these items when changing oil.

No.	PART NO	DESCRIPTION	QTY
1	EJ14-0022B	Engine Oil Filter	1
2	TG14-0518A	Hydraulic Filter	3
3	EJ15-0024A	Fuel Filter Element	1
4	P608665A	Air Filter Ass'y	1
5	P606121	Air Inner Filter	1

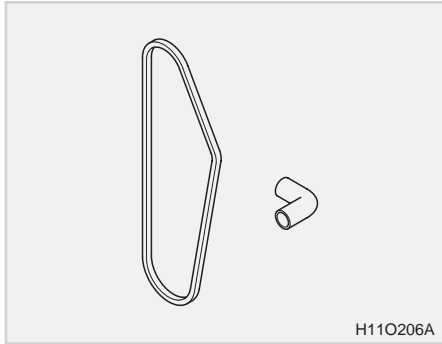
**BELTS AND RUBBER PARTS**

Belts, hoses and boots, which are made of rubber, get weakened and cracked as they age. If these parts are kept left in this state, they can be broken off, leading to a serious problem in the tractor. Therefore, regularly check or replace those items to prevent the failure.

No.	PART NO	DESCRIPTION	QTY
1	EJ16-0023A	Fan Belt	1
2	TG36-0091A	A/C Belt	1

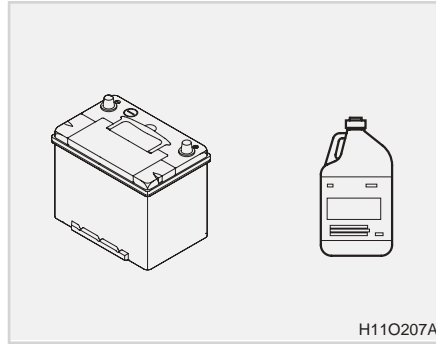
**OTHER COMPONENTS**

The battery condition is very important for engine start performance especially in winter.

Therefore, make sure to check its condition daily.

No.	PART NO	DESCRIPTION	QTY
1	TG35-0134A	Battery(230AH)	1



## WARRANTY

All products produced and sold by **KIOTI** have been designed and manufactured with strict quality control in order to comply with all laws and regulations related to agricultural equipment. Hence, by maintaining and using this product in accordance with the inspection and maintenance intervals as well as the instructions outlined in the user's manual, we are certain that you will always be able to safely keep the product in optimal working and performing condition. We hereby guarantee the following as per the relevant regulations.

### **1. Warranty Coverage**

**KIOTI** offers free repair or replacement of parts with either new parts or assemblies approved by **KIOTI** in cases where technical analysis reveals that a malfunction has occurred due to the quality of materials or a manufacturing flaw in the various components which constitute the agricultural machine during the warranty period and within the amount of guaranteed hours of use if the product which you purchased has been maintained and used normally in accordance with the inspection and maintenance intervals as well as the instructions outlined in the "user's manual" provided by **KIOTI**.

### **2. Warranty Period and Related Parts**

Warranty conditions may vary depending on the agency or dealership, so please confirm the warranty conditions for this product with the dealership from which it was purchased.

### **3. Responsibilities as Owner of the Agricultural Machine**

- (1) Please maintain and use the product in accordance with the inspection and maintenance intervals as well as the instructions designated in the user's manual.
- (2) Inappropriate inspection, maintenance or use of parts may diminish the performance of the various components of the agricultural machine or paralyze the function of the exhaust purification device, leading to fatal damage. Hence, you must perform the inspections and maintenance designated in the user's manual and warranty.

### **4. Warranty Repair Procedure**

Please consult the dealership from which you purchased the product for warranty repairs.

### **5. Warranty Transfer**

In the event that the owner changes during the warranty period due to the agricultural machine being sold, donated, etc., the warranty may be transferred for the remainder of the warranty period, so the new owner must also be given the guarantee for the product.



**6. Items Not Covered by the Warranty. (the following cases, even during the warranty period)**

- (1) Items which must be inspected regularly in accordance with the inspection schedule in the user's manual for regular scheduled maintenance.  
ex) Cleaning the fuel system, Inspecting and adjusting brakes, etc.
- (2) Intact consumable parts which are used during operation of the machinery and their service life is expired or have not been replaced on time. (however, this excludes cases of manufacturing defects)  
ex) Filters, elements, rubber products, plastic products, bulbs, fuses, belts, wires, clutch disc, etc.
- (3) Cases where a malfunction or defect is deemed to have occurred due to not using the designated oil. (using low-grade or contaminated fuel)
- (4) Cases where the company deems a malfunction to have occurred due to not performing maintenance or complying with information stated in the user's manual, on precautionary stickers, etc. or failing to perform inspection and maintenance for the malfunction.
- (5) Malfunctions which occur due to modifying or changing the structure, function, etc. of the product without approval, or not using genuine parts.
- (6) Cases where a malfunction has occurred due to a cold- or heat-induced rupture or electric discharge caused by inattentiveness to the storage and maintenance of the agricultural machine.
- (7) Sensory phenomena which are deemed to have no influence on general quality or function. (light noise, vibrations, smells, exterior, operating sensation, etc.)
- (8) Cases where the records of the agricultural machine (engine, vehicle, transmission number, etc.) differ from computerized records.
- (9) Cases where the product has been used with a malfunctioning hour meter, or the hours of use cannot be determined due to modification.
- (10) Cases of malfunctions due to natural disasters or accidents.





MEMO





# SPECIFICATIONS

**GENERAL SPECIFICATIONS ..... 3-2**

EXTERNAL DIMENSIONS .....3-2

GENERAL SPECIFICATIONS.....3-3

NOISE LEVELS AS PERCEIVED BY THE OPERATOR.....3-6

VIBRATION LEVELS OF THE TRACTOR EXPOSITION TO  
VIBRATIONS.....3-6

**TRAVELING SPEED ..... 3-8**

**IMPLEMENT LIMITATIONS ..... 3-10**

STANDARD SIZE BY IMPLEMENT .....3-10

# 3

3

## GENERAL SPECIFICATIONS EXTERNAL DIMENSIONS

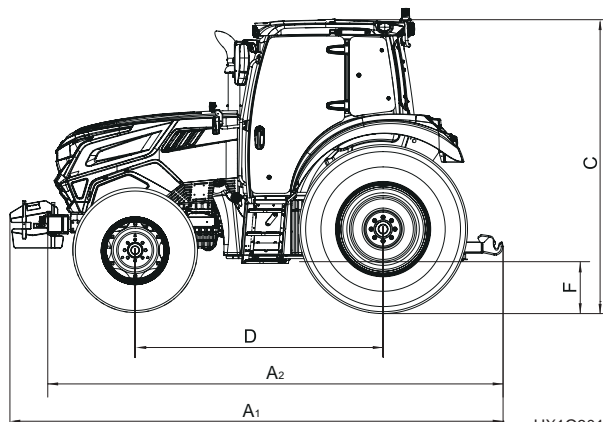
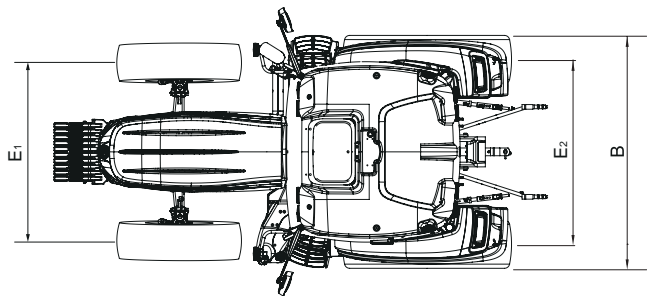

HX10301A

※ These dimensions are measured with standard tires (AG) installed on the CABIN model tractor.

in. (mm)

ITEM	MODEL		REMARK
	HX9010	HX1001 HX1151 HX1201	
1. Overall length (A1)	187.7 (4,767)	←	
2. Overall length (A2)	170.8 (4,338)	←	US
	173.1 (4,398)	←	EU
3. Overall width (B)	88.6 (2,250)	←	
4. Overall height (C)	111.9 (2,843)	←	
5. Wheel base (D)	94.9 (2,410)	←	
6. Tread (E1)	65.4 (1,660)	66.1 (1,680)	
7. Tread (E2)	70.5 (1,790)	←	
8. Ground clearance (F)	18.9 (481)	←	

※ E1 : Front wheel tread      E2 : Rear wheel tread





## GENERAL SPECIFICATIONS

ITEM		MODEL [POWER SHUTTLE]			Remark	
		HX9010PC	HX1001PC	HX1151PC/1201PC		
Engine	Model	4J243TA-TP5B	4J243TA-TP5B	4J243TA-TP5B	US	
		4JTA-TP5A	4JTA-TP5A	4JTA-TP5A	EU	
	No.of cylinders	4	←	←		
	Total displacement	cu in. (cc)	233.9 (3,833)	←	←	
	Bore & Stroke	in. (mm)	4.06 X 4.53 (103 X 115)	←	←	
	Engine Gross(Base) Power	HP (kW)	90.0 (67.1)	99.9 (74.5)	115.3 (86.0)	
	Engine Gross(Base+Boost) Power	HP (kW)	98.6 (73.5)	110.0 (82.0)	125.4 (93.5)	
	Rated PTO Power	HP (kW)	70 (52.25)	80.6 (60.2)	83.9 (62.6)	
	Rated Revolution	rpm	2,200	←	←	
Capacity	Fuel tank	U.S.gal. (ℓ)	47.6 (180)	←	←	
	Urea tank	U.S.gal. (ℓ)	4.7 (18)	←	←	
	Transmission Oil	U.S.gal. (ℓ)	20.34 (77)	←	←	
	Front axle Oil	U.S.gal. (ℓ)	2.6 (10.0)	←	←	
	Front axle case	U.S.gal. (ℓ)	0.2 + 0.2 (0.9 + 0.9)	←	←	
	Engine Oil (filter include)	U.S.gal. (ℓ)	3.9 (15)	←	←	
	Engine Coolant	U.S.gal. (ℓ)	4.6 (17.4)	←	4.7 (18.0)	



ITEM			MODEL [POWER SHUTTLE]			Remark	
			HX9010PC	HX1001PC	HX1151PC/1201PC		
Drive Train	Main Clutch Type		Multi wet disc clutch	←	←		
	Transmission	Shuttle Type	Power shuttle	←	←		
		Main Gear Shift	High/Low hydro-clutch 2 stage X synchromesh 4 stage	←	←		
		Range Gear Shift	Constant Mesh 3 stages	←	←	US	
			Constant Mesh 4 stages	←	←	EU	
		No. of speeds	F24 X R24	←	←	US	
	F32 X R32		←	←	EU		
	Traveling Speeds (AG) mph (km/h)	Forward	1.13~23.39 (1.81~37.65)	←	←	US	
		Reverse	1.12~23.23 (1.80~37.39)	←	←		
		Forward	0.14~23.39 (0.23~37.65)	←	←	EU	
		Reverse	0.14~23.23 (0.23~37.39)	←	←		
	Front wheel drive system			Hydraulic	←	←	
	Main Brake Type			Wet Disc Type	←	←	
Mechanical Differential Lock			Rear Standard	←	←		
Tire Size	Agricultural	Front	13.6 - 24	←	←		
		Rear	18.4 - 34	←	←		



ITEM		MODEL [POWER SHUTTLE]			Remark		
		HX9010PC	HX1001PC	HX1151PC/1201PC			
Hydraulic	Pump	lpm (cc/rev)	121.0 (Main: 74.8 / Steering: 46.2)	←	←		
	Steering		Hydrostatic Power Steering	←	←		
	3 Point Lift Control Type		Electronic control	←	←		
	3-point hitch type		Category II	←	←		
	Lift Capacity	@24 in. behind lift point	lbs (kgf)	8,002 (3,630)	←	←	
		@lift point	lbs (kgf)	8,079 (3,665)	←	←	
No. of standard remote ports on the valve (Front/Rear)			(4 / 4)	←	←		
PTO	Rear	Type	Independent	←	←		
		PTO shaft specifications	SAE 1-3/8, 6 spline	←	←		
		1 / 2 / 3 stages	rpm	540 / 750 / 1,000	←	←	
Min. turning radius (With one rear wheel braked)	ft (mm)	Left	12.7 (3,870)	←	←		
		Right	12.3 (3,740)	←	←		
Weight with Cabin and AG tires		lbs (kgf)	9,762 (4,428)	←	←		
Max. Draw-bar vertical load		lbs (kgf)	3,307 (1,500)	←	←		
Max. Trailer loading weight		lbs (kgf)	9,921 (4,500)	←	←	US	
			7,716 (3,500)	←	←	EU	

※ The specifications are subject to change without notice.



## NOISE LEVELS AS PERCEIVED BY THE OPERATOR

The following tables give the noise level values, measured from the driver's seat in instantaneous conditions in compliance with standards No.1322/2014(RVCR) AnnexXIII.

Item	Tractors with Cabin
Regulation	(EU)No.1322/2014(RVCR) AnnexXIII (Internal)
Permissible sound level	82.5 dB(A)

## VIBRATION LEVELS OF THE TRACTOR EXPOSITION TO VIBRATIONS

### WARNING

- *The vibration level transmitted to the body as a whole depend on different parameters, some of them relating to the machine, others to the terrain and many specific for the operator. The prevailing parameters are the type of terrain or work surface and the ground speed.*
- *Vibrations cause discomfort for the operator and in some cases put his/her health and safety at risk.*
- *Make sure that the tractor is in good condition and that all routine servicing is correctly and regularly carried out.*
- *Check tire pressure and the steering and braking systems.*
- *Check that the operator's seat and adjustment systems are in good condition, then adjust the seat to the operator's weight and size.*

**⊕ IMPORTANT**

- **More information on Whole Body Vibration (WBV) on agricultural tractors can be found in more specific publications and the relative risks can be taken into account following the laws of the country. In order to correctly estimate statistical values based on your daily work on the tractor, a specific measure instrument is required, such a three-axis accelerometer applied to the seat**

In accordance to Commission Delegated Regulation (EU) No. 1322/2014 the following table shows vibration levels measured on seats, in aws.

3

Operator's Vibration level			
Seat type	Commission Delegated Regulation (EU)	Light-weight operator	Heavy-weight operator
MSG85	1322/2014	1.24 m/s <sup>2</sup>	1.10 m/s <sup>2</sup>
MSG75GL	1322/2014	1.00 m/s <sup>2</sup>	1.20 m/s <sup>2</sup>

\* aws = Correct weighted value of the vibration acceleration (m/s<sup>2</sup>)

## TRAVELING SPEED

[24X24]

mph (Km/h)

OPERATING THE LEVER		Tire Size: 18.4-34, 10PR (Ag)			
		LOW SPEED		HIGH SPEED	
RANGE	MAIN	FORWARD (@ rated rpm)	REVERSE (@ rated rpm)	FORWARD (@ rated rpm)	REVERSE (@ rated rpm)
Low(L)	1	1.13 (1.81)	1.12 (1.80)	1.37 (2.20)	1.36 (2.19)
	2	1.47 (2.37)	1.46 (2.36)	1.79 (2.88)	1.78 (2.86)
	3	1.92 (3.08)	1.90 (3.06)	2.33 (3.74)	2.31 (3.72)
	4	2.50 (4.03)	2.48 (4.00)	3.04 (4.89)	3.02 (4.85)
Middle(M)	1	3.13 (5.03)	3.10 (5.00)	3.79 (6.11)	3.77 (6.06)
	2	4.09 (6.58)	4.06 (6.54)	4.96 (7.99)	4.93 (7.93)
	3	5.32 (8.56)	5.28 (8.50)	6.45 (10.39)	6.41 (10.32)
	4	6.94 (11.17)	6.89 (11.09)	8.42 (13.56)	8.37 (13.46)
High(H)	1	8.68 (13.97)	8.62 (13.87)	10.54 (16.96)	10.46 (16.84)
	2	11.36 (18.28)	11.28 (18.15)	13.78 (22.18)	13.69 (22.03)
	3	14.77 (23.77)	14.67 (23.60)	17.93 (28.85)	17.80 (28.65)
	4	19.27 (31.02)	19.14 (30.80)	23.39 (37.65)	23.23 (37.39)

※ The specifications are subject to change without notice.



[32X32]

mph (Km/h)

OPERATING THE LEVER		Tire Size: 18.4-34, 10PR (Ag)			
		LOW SPEED		HIGH SPEED	
RANGE	MAIN	FORWARD (@ rated rpm)	REVERSE (@ rated rpm)	FORWARD (@ rated rpm)	REVERSE (@ rated rpm)
Creep(C)	1	0.14 (0.23)	0.14 (0.23)	0.17 (0.28)	0.17 (0.27)
	2	0.19 (0.30)	0.18 (0.30)	0.22 (0.36)	0.22 (0.36)
	3	0.24 (0.39)	0.24 (0.38)	0.29 (0.47)	0.29 (0.47)
	4	0.31 (0.51)	0.31 (0.50)	0.38 (0.61)	0.38 (0.61)
Low(L)	1	1.13 (1.81)	1.12 (1.80)	1.37 (2.20)	1.36 (2.19)
	2	1.47 (2.37)	1.46 (2.36)	1.79 (2.88)	1.78 (2.86)
	3	1.92 (3.08)	1.90 (3.06)	2.33 (3.74)	2.31 (3.72)
	4	2.50 (4.03)	2.48 (4.00)	3.04 (4.89)	3.02 (4.85)
Middle(M)	1	3.13 (5.03)	3.10 (5.00)	3.79 (6.11)	3.77 (6.06)
	2	4.09 (6.58)	4.06 (6.54)	4.96 (7.99)	4.93 (7.93)
	3	5.32 (8.56)	5.28 (8.50)	6.45 (10.39)	6.41 (10.32)
	4	6.94 (11.17)	6.89 (11.09)	8.42 (13.56)	8.37 (13.46)
High(H)	1	8.68 (13.97)	8.62 (13.87)	10.54 (16.96)	10.46 (16.84)
	2	11.36 (18.28)	11.28 (18.15)	13.78 (22.18)	13.69 (22.03)
	3	14.77 (23.77)	14.67 (23.60)	17.93 (28.85)	17.80 (28.65)
	4	19.27 (31.02)	19.14 (30.80)	23.39 (37.65)	23.23 (37.39)

※ The specifications are subject to change without notice.

## IMPLEMENT LIMITATIONS STANDARD SIZE BY IMPLEMENT

This **KIOTI** tractor has been thoroughly tested for proper performance with implements sold or approved by **KIOTI**. Use with implements which are not sold or approved by **KIOTI** and which exceed the maximum specifications listed below, or which are otherwise unfit for use with this **KIOTI** tractor may result in malfunctions or failures to the tractor, damage to other property and injury to the operator or others. [Any malfunctions or failures to the tractor resulting from use with improper implements are not covered by the warranty.]

Model	Item	Tread (max. width)		Lifting Capacity max. loading weight $W_0$ (24 in. aft of hitch)
		Front	Rear	
HX9010		65.4 in. (1,660 mm)	70.5 in. (1,790 mm)	8,002 lbs. (3,630 kg)
HX1001/1151/1201		66.1 in. (1,680 mm)	70.5 in. (1,790 mm)	

Model	Item	Actual figures		Trailer loading weight $W_3$ Max. capacity
		Implement weight $W_1$ and / or size	Max. Drawbar Load $W_2$	
HX9010/1001/1151-US	As in the following list (shown on the next page)		3,307 lbs. (1,500 kg)	9,921 lbs. (4,500 kg)
HX9010/1001/1201-EU				7,716 lbs. (3,500 kg)

Lifting Capacity max. loading weight ..... The max. allowable load which can be put on the 24 in. aft of hitch :  $W_0$

Implement weight ..... The implement's weight which can be put on the lower link :  $W_1$

Max. drawbar load .....  $W_2$

Trailer loading weight ..... The max. loading weight for trailer (without trailer's weight) :  $W_3$

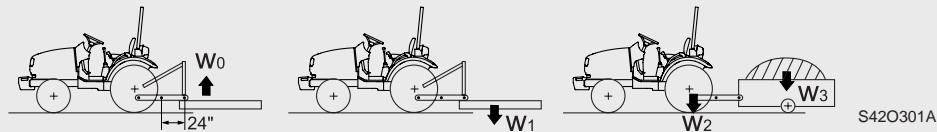

**NOTE** : Implement size may vary depending on soil operating conditions.





IMPLEMENT	DESCRIPTION	REMARKS
Loader	Max. Bucket width	84 in. (2,134 mm) bucket
Backhoe with sub frame	Max. Diging depth	N/A, 3-point mounting is not recommended by DAEDONG
Tiller	Max. Cutting width	Not recommended unless rated for 80 PTO HP
Box Blade	Max. Cutting width	96 in. (2,438 mm) maximum or rated for 80 PTO HP w/FWA
Rear Blade	Max. Cutting width	180 in. (4,572 mm) maximum or rated for 80 PTO HP w/FWA
Rotary Cutter	Max. Cutting width	Not to exceed 180 in. (4,572 mm) pull type or lift or a 80 PTO HP rating
Aerator	Max. width	96 in. (2,438 mm) maximum or rated for 80 PTO HP w/FWA
Landscape Rakes	Max. width	96 in. (2,438 mm) maximum or rated for 80 PTO HP w/FWA

**NOTE** : This is a sample of attachments commonly used. Before purchasing or using any attachment on a **DAEDONG** product, please review the specifications to determine if it is a compatible product. Damages or failures due to improper use of compatibility issue will not be covered by warranty. If you have questions concerning product compatibility or warranty, please consult with your local **DAEDONG** Dealer.



MEMO





## DESCRIPTION OF OPERATING SYSTEM

### EXTERIOR VIEW ..... 4-4

### SWITCH..... 4-5

MOUNTING LOCATION .....	4-5
KEY SWITCH.....	4-6
COMBINATION SWITCH.....	4-7
HAZARD LAMP SWITCH .....	4-9
PTO CRUISE ON/OFF SWITCH.....	4-10
PTO RESTART/SETTING SWITCH.....	4-10
POWER BOOST FUNCTION .....	4-11
DPF REGENERATION SWITCH.....	4-11
ECO/MODE SELECTION SWITCH .....	4-13

### INSTRUMENT PANEL ..... 4-14

TACHOMETER / HOUR METER .....	4-15
PTO SPEED MARK.....	4-15
FUEL GAUGE .....	4-15
ENGINE COOLANT TEMPERATURE GAUGE .....	4-16
ENGINE OIL PRESSURE WARNING LAMP ..	4-17
BATTERY CHARGING LAMP .....	4-17
HEAD LIGHT HIGH BEAM LAMP .....	4-18

TURN SIGNAL LAMP.....	4-18
GLOW PLUG LAMP .....	4-18
PARKING BRAKE LAMP .....	4-19
PTO LAMP .....	4-19
4WD LAMP.....	4-19
QUICK-TURN LAMP .....	4-20
AUTO DRAFT LAMP .....	4-20
BRAKE(ONE SIDE) LAMP.....	4-21
CRUISE PTO LAMP.....	4-21
DPF REGENERATION WARNING LAMP ..	4-22
DPF REGENERATION UNDERWAY LAMP ...	4-22
ENGINE CHECK WARNING LAMP .....	4-24
LOW UREA LEVEL WARNING LAMP .....	4-24
WATER-IN-FUEL WARNING LAMP .....	4-25
LOW FUEL LEVEL WARNING LAMP .....	4-25
EMISSION WARNING LAMP .....	4-26
ERROR INDICATOR .....	4-26

### OPERATING THE CONTROLS ..... 4-28

SHUTTLE SHIFT LEVER .....	4-29
MAIN SHIFT LEVER .....	4-30
RANGE GEAR SHIFT LEVER.....	4-31

# 4



## DESCRIPTION OF OPERATING SYSTEM

PTO SHIFT LEVER .....	4-32	IMPLEMENT ADJUSTMENT SWITCH .....	4-45
PTO SELECTION LEVER .....	4-33	DIFFERENTIAL LOCK PEDAL (REAR).....	4-48
CLUTCH PEDAL .....	4-34	SEAT ADJUSTMENT .....	4-48
BRAKE PEDAL .....	4-34	JOYSTICK LEVER .....	4-51
STEERING WHEEL ADJUSTMENT .....	4-35	DOUBLE ACTING LEVER .....	4-53
TELESCOPING FUNCTION.....	4-35	<b>CABIN SYSTEM .....</b>	<b>4-54</b>
PARKING BRAKE LEVER .....	4-36	INTERIOR DEVICES .....	4-54
PARKING LOCK LEVER.....	4-36	EXTERIOR DEVICES .....	4-55
FOOT THROTTLE.....	4-37	ENTRANCE .....	4-55
HAND THROTTLE LEVER .....	4-37	UNLOCKING THE DOOR.....	4-56
PTO MAIN SWITCH.....	4-38	REAR WINDOW .....	4-56
PTO AUTO/MANUAL SWITCH.....	4-39	WORKING LIGHT .....	4-57
REMOTE PTO FUNCTION.....	4-39	WIPER.....	4-57
DRIVING SELECTION SWITCH.....	4-40	ANTENNA .....	4-58
OPERATION/DRIVING RESPONSE SET- TING BUTTON .....	4-42	ROOM LAMP .....	4-59
CALIBRATION BUTTON.....	4-42	ACCESSORY.....	4-59
BEACON LIGHT BUTTON (IF EQUIPPED)....	4-42	REFRIGERATOR / HEATING CABINET ...	4-61
DEFROST BUTTON.....	4-43	SUNSHADE .....	4-61
IMPLEMENT ADJUSTMENT CONTROLLER... 4-44		SUNROOF .....	4-62
ADJUSTING THE IMPLEMENT OPERA- TION CONTROLLER HEIGHT .....	4-45	EMERGENCY HAMMER (ONLY EU MOD- EL).....	4-62



## DESCRIPTION OF OPERATING SYSTEM

HEATER AND AIR CONDITIONER .....	4-63
7-PIN POWER OUTPUT SOCKET .....	4-67
TIRES, WHEELS AND BALLAST.....	4-68
INFLATION PRESSURE.....	4-69
TREAD .....	4-70
WHEEL TORQUE AND DIRECTION.....	4-73
ADDITIONAL WEIGHT(IF EQUIPPED).....	4-74
MASS(ES) AND TIRE(S).....	4-78

# 4

## 4



4-4 HX9010/1001/1151/1201

## EXTERIOR VIEW

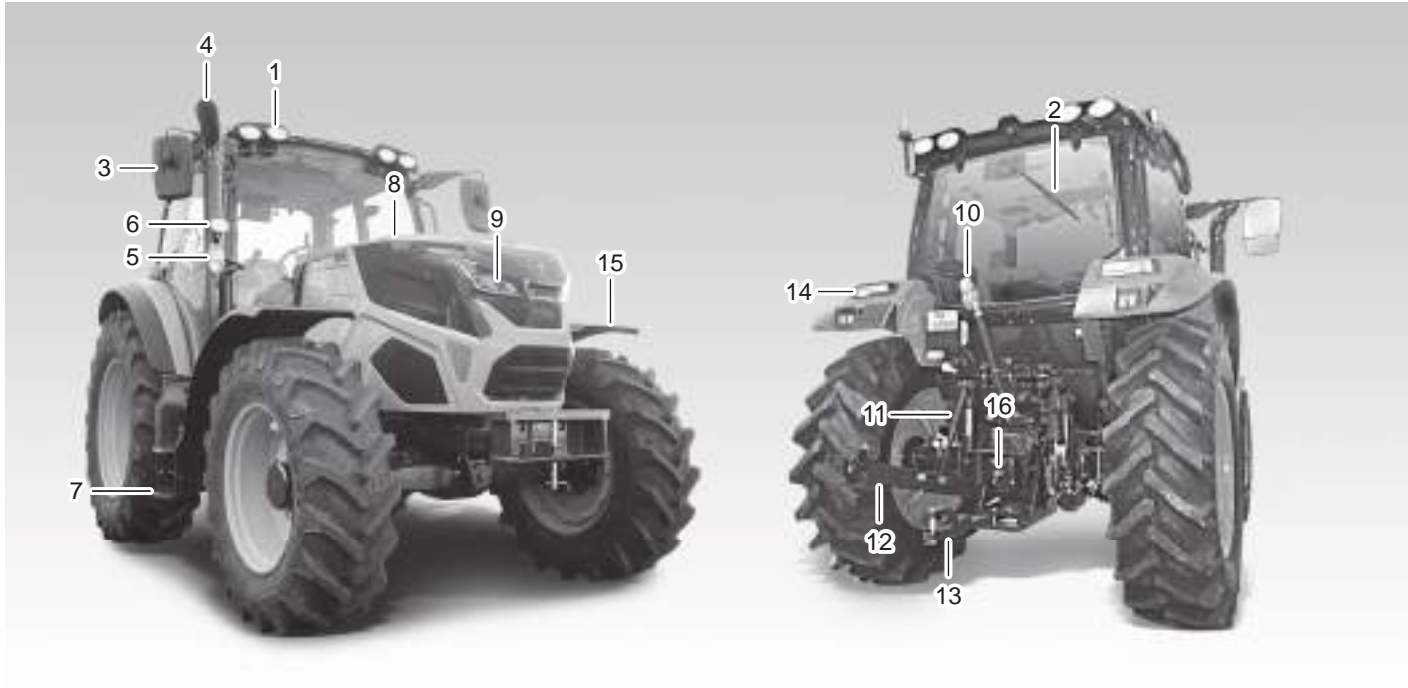

HX10480A

(1) Working Lamp (FRT/RR)  
(2) Wiper  
(3) Rear View Mirror  
(4) Muffler

(5) Turn Signal Lamp (FRT/RR)  
(6) Working Lamp  
(7) Step  
(8) Bonnet

(9) Head Lamp  
(10) Top Link  
(11) Lift Rod  
(12) Lower Link

(13) Draw-bar  
(14) Tail Lamp  
(15) Front Fender  
(16) PTO Shaft



## SWITCH MOUNTING LOCATION [POWER SHUTTLE(PC) MODEL]



- (1) Instrument Panel
- (2) Combination Switch
- (3) Hazard Lamp Switch
- (4) Key Switch
- (5) PTO Cruise Res(+)/Set(-) Switch
- (6) PTO Cruise ON/OFF Switch
- (7) Power Boost ON/OFF Switch
- (8) DPF Regeneration Switch
- (9) ECO Mode/ECO Lamp Switch

## KEY SWITCH



(1) Key switch

(A) OFF                    (B) ACC  
(C) ON                     (D) START

### • OFF (A)

When the key switch is in the position "A", the engine and all electrical devices in the vehicle are turned off. However, flasher lights and turn signal lights can be operated along with their indication lamps on the dash board.

### • ACC (B)

When the key switch is turned to the position "B", the flasher lights and turn signal lights can be operated.

### • ON (C)

The position "C" indicates the "ON" position. As soon as the key switch is turned to this position, the oil pressure warning lamp and battery charge warning lamp come on (these turn off after the engine is started) and the automatic preheating function is activated.

The automatic preheating operation is informed by illumination of the pre-heat lamp on the instrument cluster. In cold weather, preheat the engine sufficiently until the preheat lamp goes off (approx. 9 seconds).

### • START (D)

The position "D" indicates "Start." In order to start the engine, depress the clutch pedal and turn the PTO switch off. As soon as the engine is started, release the key then the key will return to the position "C."

### CAUTION

- **Stop the engine immediately if the oil pressure warning lamp does not go off after the engine is started. The engine may be severely damaged.**
- **If the battery charge warning lamp does not go off after the engine is started, check the electrical systems, such as the alternator, for damage. Continuing to use the engine under this condition can discharge the battery or damage other electrical devices.**

### NOTE

- The ignition key is directional, so it can be inserted only in a certain direction. Also, be careful not to leave the tractor unattended as the same key is used for all **KIOTI** tractors. It can be stolen.
- The horn, turn signal lamp, and hazard lamp can be operated without the key inserted.



### NOTE

- When setting the ignition switch to the OFF position after operation, the pump is operated to return urea left in the urea pump and injector back to the tank, making a ticking sound. This is normal.
- Do not set the battery cut-off switch to the OFF position or disconnect the battery during this state.
- This takes for approximately two minutes.

## COMBINATION SWITCH

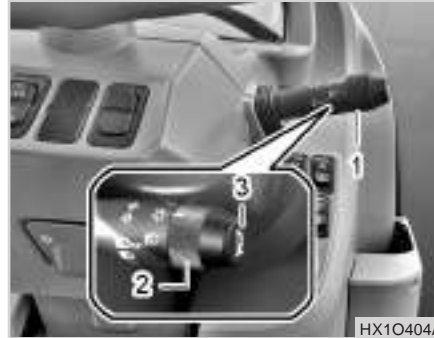

- (1) Turn Signal Light Switch  
 (2) Head Light Switch      (3) Horn Switch

The combination switch consists of the head light, turn signal light, and horn switches. Its function by its position is as follows :

"OFF" : Head light and tail light "OFF"

☰☉ : Low beam and tail light "ON"

☰☉ : High beam "ON"

↔ : Turn signal light and tail light "ON"

☰☉ : Head light "OFF" and tail light "ON"

## HEAD LIGHT SWITCH



- (1) Head Light Switch  
 (A) OFF      (B) Instrument Panel ON  
 (C) Low Beam ON      (D) High Beam ON

The head light switch can be operated only while the key switch is turned to the "ON" position. Turning the head light switch clockwise one click will illuminate the instrument panel lights while turning it one more click will illuminate the low beam head lights.



**⚠ WARNING**

- *Driving with high beam head light disturbs the approaching vehicle's visibility for safe driving. Use the high beam head lights only if necessary.*

**TURN SIGNAL LIGHT SWITCH**



HX1O406B

(1) Turn Signal Light Switch  
(A) Left Turn (B) Right Turn

The turn signal lights are used when turning the vehicle left or right. Pulling the lever up blinks the left turn signal light while pushing the lever down blinks the right turn signal light.

**📖 NOTE**

- Make sure to control the work load so that the needle is not in the red zone.

**📖 NOTE**

- If the needle stays in the red zone, do not stop the engine immediately. Instead, reduce the work load to cool down the engine before stopping the engine.
- Make sure to keep the front grill clean so that air is sucked through it freely for fast cooling.

**HORN SWITCH***(1) Horn Switch*

The horn switch can be operated without the key inserted. Pressing this switch sounds the horn.

**HAZARD LAMP SWITCH**

*(1) Hazard Lamp Switch*  
*(A) ON*                      *(B) OFF*

This switch can be used to warn other vehicles when malfunction occurs in the tractor while driving on a public road. Pressing this switch up blinks the hazard lamp and returning it turns off the lamp. The turn signal lights cannot be operated while this switch is pressed up to operate the hazard lamps.

**CAUTION**

- If the hazard lamps are turned on for an extended period of time while the engine is stopped, the battery can be discharged. Therefore, use them only in emergency.
- The hazard lamp can be operated without the key inserted.

### PTO CRUISE ON/OFF SWITCH



(1) PTO Cruise ON/OFF Switch  
(A) ON (B) OFF

It is a function to control the engine rpm for comfortable driving at engine 1,300rpm or higher.

### PTO RESTART/SETTING SWITCH PTO CRUISE ACTIVATION



(1) PTO Restart (Res +)/Setting (Set -) Switch  
(A) Restart (Res +) (B) Setting (Set -)

Run the engine at a speed over 1,300 RPM. With the brake and clutch pedals released, set the PTO cruise switch to the ON position and press the SET (1) portion of the cruise activation switch

The cruise setting switch can be operated as follows while the PTO cruise function is activated.

- RES(+) : Speed is increased by 50 RPM when pressing it.
- SET(-) : Speed is decreased by 50 RPM when pressing it.

### PTO CRUISE DEACTIVATION

Depress the brake pedal or clutch pedal or set the PTO cruise switch to the "OFF" position to deactivate the PTO cruise function.

If the PTO cruise function is deactivated by depressing the brake or clutch pedal with the PTO cruise switch set in the "ON" position, pressing the RES(+) switch once resumes the previous PTO activation setting.

#### **+** IMPORTANT

- **If the brake pedals are not connected to each other, depressing the brake pedal does not deactivate the PTO cruise function.**

## POWER BOOST FUNCTION

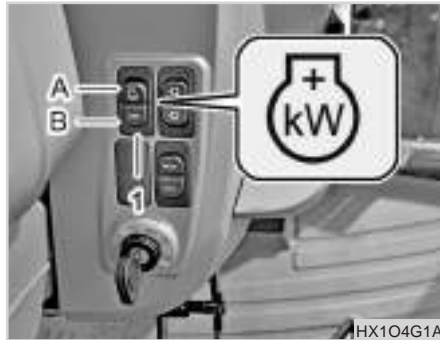

(1) Power Boost Button  
(A) ON (B) OFF

Power boost is a function that increases the output from the rated or maximum output when the power boost button is turned on during a specific operation.

### 1. POWER BOOST FUNCTION SETTING

When the button is pressed, the function is activated and the green LED on the switch turns on when the function is activated.

### 2. POWER BOOST CONDITIONS

If one or more of the two conditions are satisfied, the power boost function is activated.

- 1) When working with PTO: PTO main switch "ON" + vehicle speed of 0.5km/hr or more
- 2) Driving: Vehicle speed 15km/hr or higher (Lamp turns off and inactive at 13km/hr or less)

## DPF REGENERATION SWITCH



(1) DPF Regeneration Switch  
(A) Activation (B) Deactivation

### ACTIVATION (UPPER PORTION OF SWITCH)

Perform the following instructions when the regeneration warning lamp (  ) comes on:

1. Park the tractor on a flat surface.
2. Run the engine at idle. The speed adjustment lever should be at low speed.
3. Put all shift levers in the neutral position.
4. Apply the parking brake.

5. If the coolant temperature is over 20°C and the pressure difference in the DPF is more than 120%, press the button for about 2 seconds to start regeneration.
6. When the DPF regeneration lamp goes off, restart the work after idling for about 3 minutes at low speed idle. DPF manual regeneration takes about 20 minutes.

 **NOTE**

- During manual regeneration of DPF, the poisoned components are burned in the catalyst, so the smell of burning oil may be emitted.
- Natural DPF regeneration works every 200 hours.

**DEACTIVATION (LOWER PORTION OF SWITCH)**

Do not press the deactivation portion of the switch while the regeneration process is activated.

However, the switch can be set to the deactivation position to stop the regeneration process in emergency.

 **CAUTION**

**To protect the catalyst filter, keep the followings:**

- **Make sure to use only specified fuel.**
- **Keep the engine oil replacement schedule.**
- **Check the engine oil level frequently to keep it to the specified level.**
- **Avoid any unnecessary engine idling.**
- **Never stop the engine during driving.**
- **Never place the shift lever in the neutral position when driving downhill.**
- **Do not use any engine oil additive or fuel additive.**
- **Avoid driving with any warning lamp illuminated.**
- **Do not allow any flammable materials, such as dry grass and paper, to come near the catalyst filter while parked.**

## ECO/MODE SELECTION SWITCH



(1) ECO/MODE selection switch  
(A) MODE button (B) ECO button

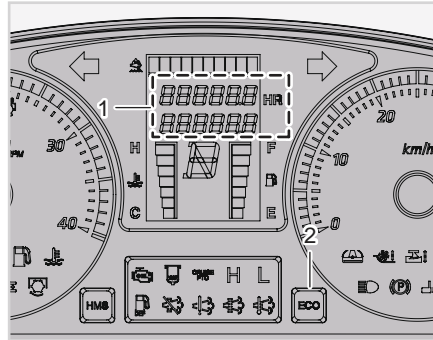

(1) Fuel consumption indicator  
(2) ECO Lamp

- ECO range comparison

<b>White</b>	Fuel efficiency - below 0 ~ 8l/h or Engine RPM - below 1,000
<b>Green</b>	Fuel efficiency - 8 ~ below 15.5l/h
<b>Red</b>	Fuel efficiency - 15.5l/h or more

- MODE button (A)

Each pressing of the MODE switch changes the indication on the instrument cluster LED in the following order:

No.	ITEM	DESCRIPTION
1	-	Odometer
2	LH	Instant fuel consumption
3	ALH	Average fuel consumption
4	L	Total fuel consumption

- ECO button (B)

Each pressing of the ECO button toggles the ECO indicator on/off. This indicator shows the level of fuel consumption: white for low consumption, green for middle level consumption and red for high fuel consumption.

# INSTRUMENT PANEL

Symbols on the instrument panel come on when the key switch is turned to the "ON" position.

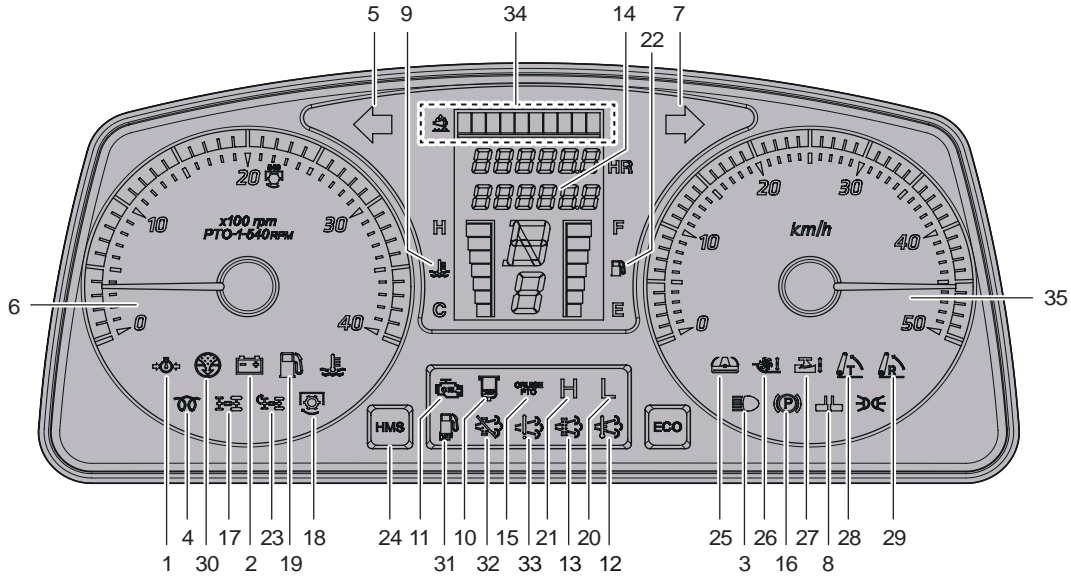

- |                                      |                                     |                                  |                                       |
|--------------------------------------|-------------------------------------|----------------------------------|---------------------------------------|
| (1) Engine Oil Pressure Warning Lamp | (10) Water Sensor Warning Lamp      | (19) Low Fuel Level Warning Lamp | (28) Turn up                          |
| (2) Battery Charge Warning Lamp      | (11) Engine Check Lamp              | (20) Low Speed Lamp              | (29) Back Up                          |
| (3) High Beam Lamp                   | (12) DPF Regeneration Underway Lamp | (21) High Speed Lamp             | (30) Air Filter Clogging Warning Lamp |
| (4) Glow Plug Lamp                   | (13) DPF Regeneration Warning Lamp  | (22) Fuel Gauge                  | (31) Urea Low Level Warning Lamp      |
| (5) Turn Signal Lamp (LH)            | (14) Hour Meter / Error Code        | (23) QT                          | (32) DPF Prohibition Warning Lamp     |
| (6) Tachometer                       | (15) Cruise PTO Lamp                | (24) HMS                         | (33) Emission Warning Lamp            |
| (7) Turn Signal Lamp (RH)            | (16) Parking Brake Lamp             | (25) Horizontal Auto             | (34) Urea Low Gauge                   |
| (8) One Side Brake Lamp              | (17) 4WD Operation Lamp             | (26) Auto tilling depth          | (35) Speed meter                      |
| (9) Coolant Temperature Gauge        | (18) PTO ON Lamp                    | (27) Auto draft                  |                                       |

TG2O468A



## TACHOMETER / HOUR ME- TER

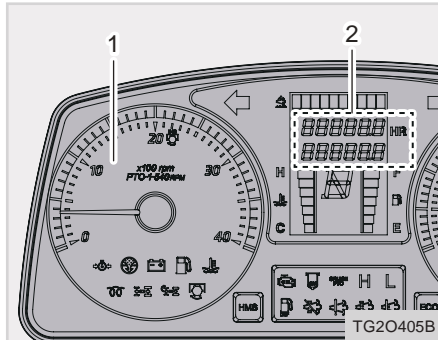

- (1) Tachometer  
(2) Hour meter Indicator

Engine rpm meter indicates the number of engine revolutions per minute. Hour meter indicates the total operating time of the tractor to six digits. The hour meter does not operate if the engine is stopped even though the key switch is in the "ON" position.

## PTO SPEED MARK

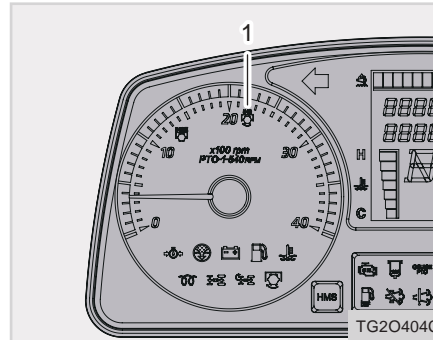

- (1) 540 rpm

The PTO speed can be selected as desired according to the operating condition. Set the engine speed around this mark for efficient and rapid work. At this time, PTO speed will be approx. 540.

## FUEL GAUGE

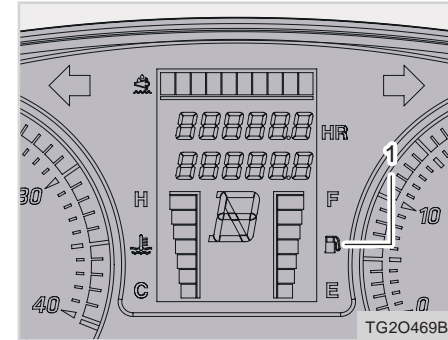

- (1) Fuel Gauge  
E: Empty                      F: Full

This indicates the remaining fuel level after the key switch is turned to the "ON" position.

- **F** : Fuel is fully filled.
- **E** : Replenish the fuel tank.

### NOTE

- Make sure to use only genuine fuel as the engine can be damaged if unqualified fuel is used.

## ENGINE COOLANT TEMPERATURE GAUGE

### NOTE

- Make sure to use only Ultra low sulfur oil for automobiles as the engine can be damaged if unqualified fuel is used.
- Use fuel for winter season in cold weather to start the engine easier.
- The gauge needle can move on a hill as fuel slopes in the tank.

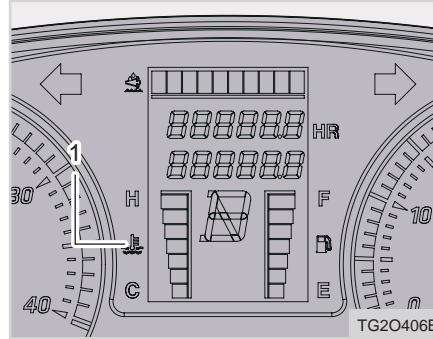

(1) Coolant Temperature Gauge  
C: Cold H: Hot

This gauge indicates the coolant temperature after the key switch is turned to the "ON" position.

- **C** : Coolant is cold.
- **H** : Coolant is hot.

The range marked in "H" in the figure indicates the abnormal engine temperature. Reduce the engine rpm immediately.

### CAUTION

- Make sure to control the work load so that the needle is not in the red zone.
- If the needle stays in the red zone, do not stop the engine immediately. Instead, reduce the work load to cool down the engine before stopping the engine.
- Make sure to keep the front grill clean so that air is sucked through it freely for fast cooling.

## ENGINE OIL PRESSURE WARNING LAMP

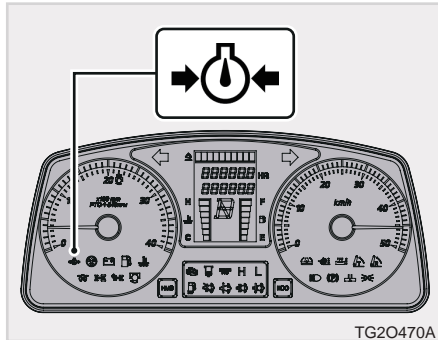

TG2O470A

### CAUTION

- If the oil level is below the specified range, the engine can seize.
- The engine can be severely damaged if driving or operating the tractor with the engine oil warning lamp ON.

This lamp comes on when the engine oil pressure or oil level is low.

If this lamp comes on while driving, stop the engine immediately and check the engine oil level.

If this lamp comes on even with the specified engine oil level, have the tractor checked by your local **KIOTI** dealer.

## BATTERY CHARGING LAMP

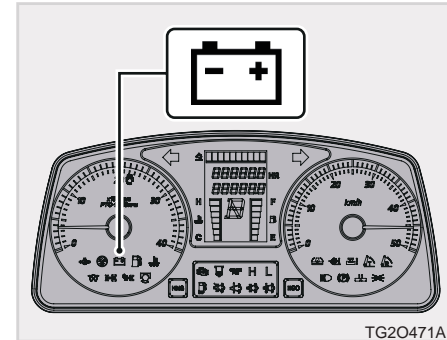

TG2O471A

4

This lamp is turned On when the starting switch is turned On before starting the engine but turned Off after starting the engine.

### CAUTION

- If this warning lamp comes on while driving, the charging system, such as the alternator, is malfunctioning. Therefore, turn off all electrical devices and have the tractor checked by your local **KIOTI Dealer**.

### HEAD LIGHT HIGH BEAM LAMP

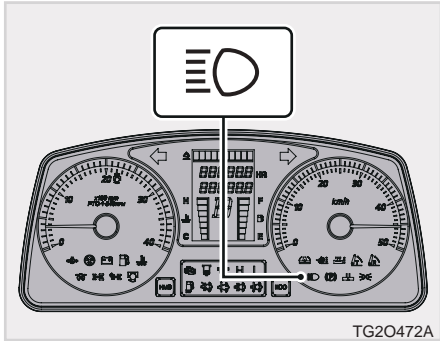

This lamp comes on in blue when the high beam head light is switched on. Driving with high beam head light disturbs an approaching vehicle's visibility. For safe driving, use the high beam head light only if necessary.

### TURN SIGNAL LAMP

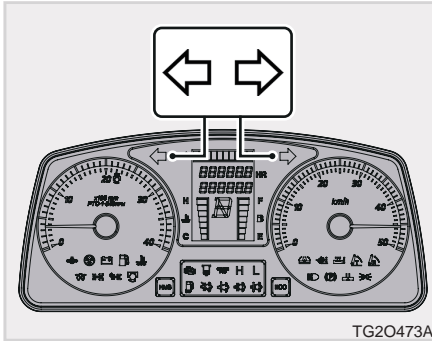

Operating the turn signal lamp switch up and down turns on the corresponding lamp in green.

### GLOW PLUG LAMP

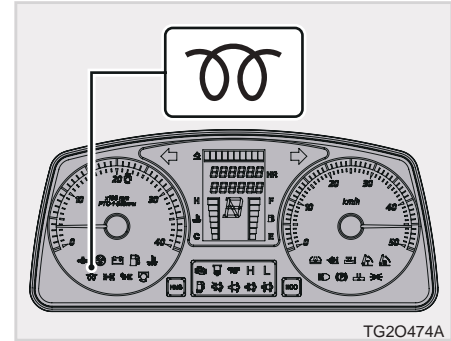

This indicates the operating condition of the preheat system. When the key switch is turned to the "ON" position, this lamp comes on. It is recommended to start the engine as soon as this lamp goes off for best starting performance. This lamp may not turn on if the engine is warm. In this case, the engine can be started without the preheat operation.

## PARKING BRAKE LAMP

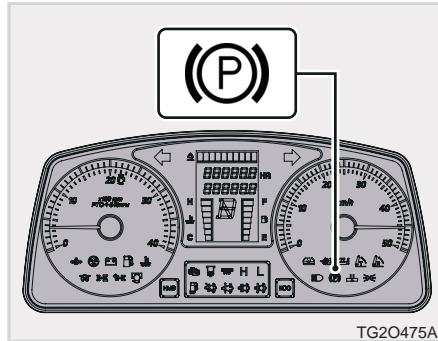

When the parking brake is actuated, the lamp lights ON.

**! CAUTION**

- If this lamp is ON even with the parking brake released, have the tractor checked by your local KIOTI dealer.

## PTO LAMP

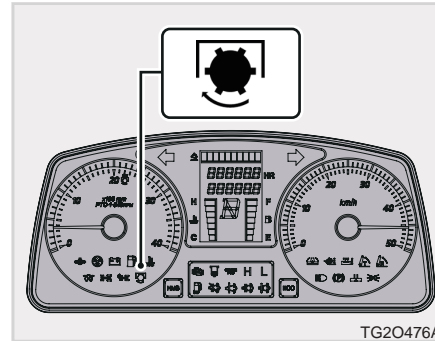

This lamp shows the PTO engagement condition. When the PTO is engaged, this lamp comes on. When the PTO clutch is disengaged, this lamp goes off.

**! CAUTION**

- Set the PTO switch to the “OFF” position in order to start the engine.

## 4WD LAMP

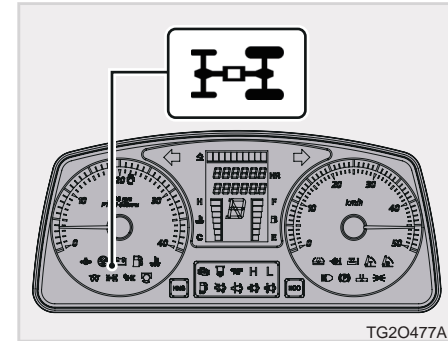

This comes on to indicate 4WD engagement.

**! CAUTION**

- The durability of the axle can be deteriorated if only one brake pedal is depressed during the 4WD is activated.

### QUICK-TURN LAMP

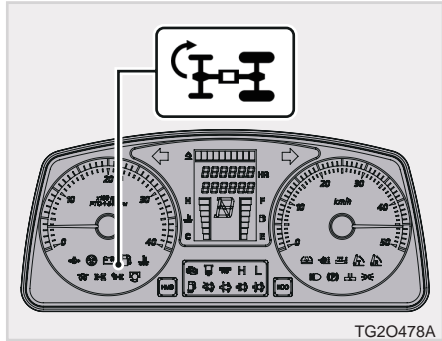

This indicates activation of the quick-turn function.

This function is activated only when the driving mode selection switch is in the “QT” position and the steering angle of the front wheels is over 35°. This function is used to reduce the turning radius by increasing the rotation speed of the outer front wheel, increasing the turning performance in the 4WD operation.

For the safety reason, this is activated only when the range shift gear is not in the low speed position.

Using the one-side brake on the corresponding side with the quick-turn function can further reduce the turning radius.

### AUTO DRAFT LAMP

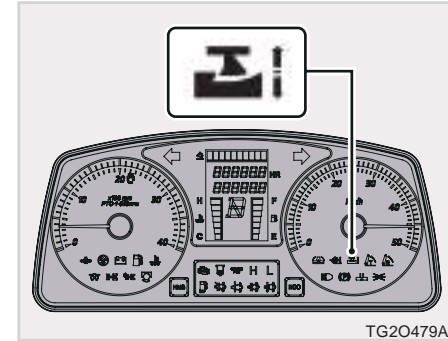

This indicates the status of the auto draft operation. In the Hitch Switch Box, press the “AUTO” switch and press the “Mode” switch twice or four times to illuminate.

**CAUTION**

- For more information on the function, refer to “Mode selection switch”. (page 4-13)

## BRAKE(ONE SIDE) LAMP

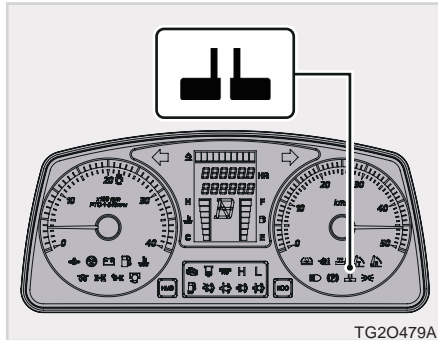

TG2O479A

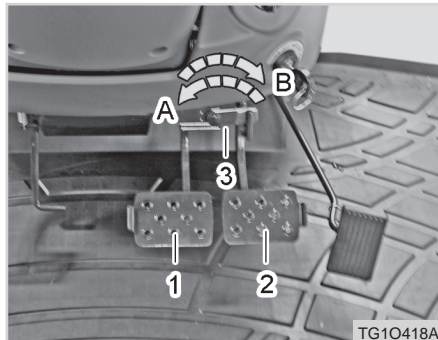

TG1O418A

- (1) Brake Pedal (LH)    (2) Brake Pedal (RH)  
 (3) Pedal Interlock  
 (A) Unlock                    (B) Lock

This lamp indicates the operating status of the brake. (One side)

This comes on when the brake pedal interlock for two brake pedals is unlocked.

### ⊕ IMPORTANT

- When driving on a public road or at a high speed, never use only one brake pedal. The tractor can roll over.
- While the brake(one side) lamp is not illuminated, the brake pedals are not interlocked. Make sure to set the pedal interlock to the “Lock” position in a normal condition.

## CRUISE PTO LAMP

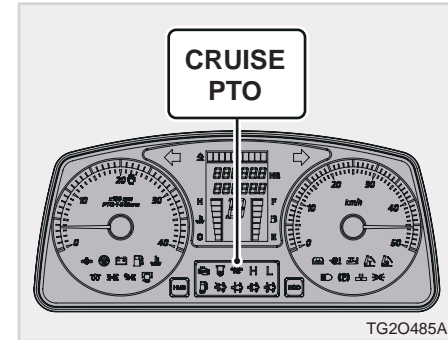

TG2O485A

4

The switch is used to set the PTO rpm. With the PTO cruise button set in the ON position, pressing the SET (-) button turns on this lamp.

### DPF REGENERATION WARNING LAMP

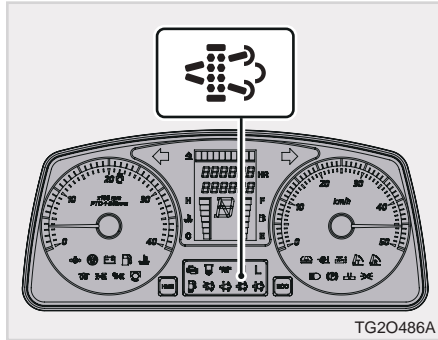

If carbon is accumulated in the exhaust DPF, this warning lamp comes on or blinks.

If this warning lamp comes on, press the "regeneration" button.

### DPF REGENERATION UNDERWAY LAMP

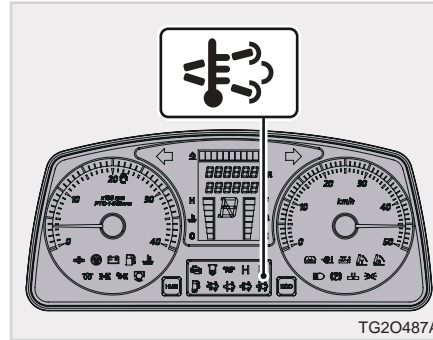

This lamp comes on while the regeneration process is being performed in the DPF.

#### ⊕ IMPORTANT

- If the DPF regeneration underway lamp is illuminated during operation, please keep the engine rpm at 1,500 or above.

#### ⚠ WARNING

- Do not touch or come near the DPF part during the regeneration process as its surrounding area is hot. If not, you can get burnt.



## DPF REGENERATION WARNING LAMP

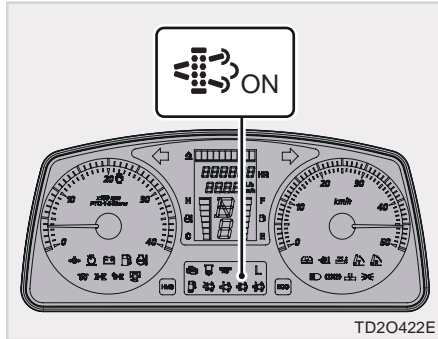

1. Stage 1 warning lamp for DPF clogging
  - : DPF Soot Loading Level 120% - 160%
  - Manual regeneration required
  - Engine RPM limit (below 2.200 rpm)

If this warning lamp comes on, make sure to press the "regeneration" button. (see page 4-11)

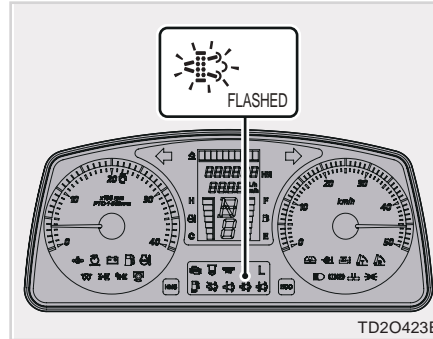

2. Stage 2 warning lamp for DPF clogging
  - : DPF Soot Loading Level 160% - 200%
  - Manual regeneration required
  - Engine RPM limit (below 2.200 rpm)

If the DPF is not regenerated in the stage 1 warning state, the warning lamp blinks. In this state, make sure to perform DPF regeneration process. (see page 4-11)

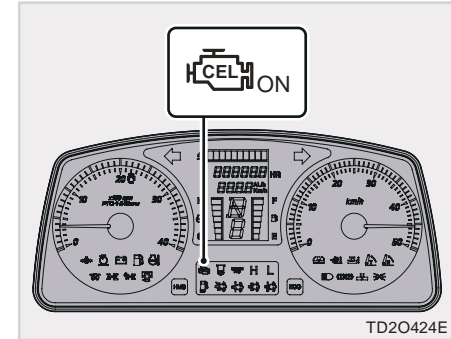

3. Stage 3 warning lamp for DPF clogging
  - : DPF Soot Loading Level 200% or higher
  - Passive regeneration prohibited
  - Engine RPM limit (below 1.500 rpm)

If the DPF is still not regenerated even in this state, the Check engine lamp comes on and the DPF needs to be replaced.

### ⚠ WARNING

- *In the warning level 3 (CEL lamp ON), both manual and automatic regeneration processes cannot be performed.*
- *When the DPF warning lamp comes on, make sure to perform the manual regeneration as the active regeneration cannot be performed.*
- *Enabling condition for manual regeneration*
  - *Clutch engaged*
  - *Brake ON*
  - *Engine rpm Idle state*
- *If any of the above conditions is not met during regeneration, the regeneration mode is deactivated.*
- *Other general operation cannot be performed during the manual regeneration process. During regeneration, the engine speed is maintained*
  - *at 1.500 rpm for 10 minutes*
  - *at 2.600 rpm for 25 minutes*
  - *at 1.600 rpm for 3 minutes*

### ENGINE CHECK WARNING LAMP

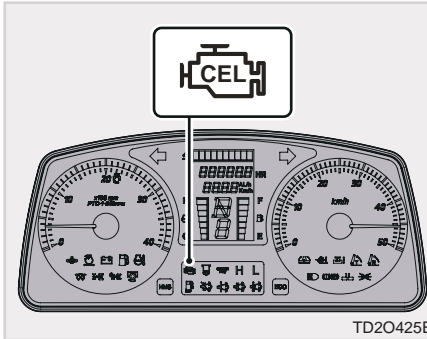

This lamp on when any major electric device or engine fuel system is malfunctioning.

### LOW UREA LEVEL WARNING LAMP

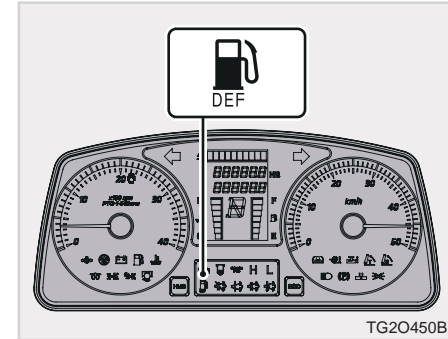

This comes on when the urea level is below 20% in the tank. It starts to blink when the urea level is below 10%.

Make sure to add more urea immediately in this case.

- 20% or less: Low urea level warning lamp on
- Less than 10%: Low urea level warning lamp "on" + emission warning lamp on

- Less than 5%: Low urea level warning lamp on + Emission warning lamp blinks slowly
- 2.5% or less: Low urea level warning lamp on + Emission warning lamp flashing fast + Engine stop warning light on

### ! WARNING

- *If you ignore the blinking urea level warning lamp and keep working, the engine power can be dropped and its speed can be forcibly lowered to the low idle speed.*
- *Also, the after treatment system can be damaged. Make sure to add genuine urea, which meets ISO22241, to the tank.*
- *Never try to use diluted urea or make one by yourself as such urea can damage the system.*

## WATER-IN-FUEL WARNING LAMP

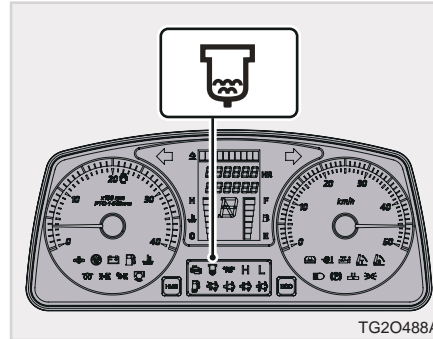

When a certain amount of water (approx. 155 cc) is accumulated in the main filter, this lamp on the instrument cluster comes on. In this case, stop the engine immediately and drain water from the fuel filter.

## LOW FUEL LEVEL WARNING LAMP

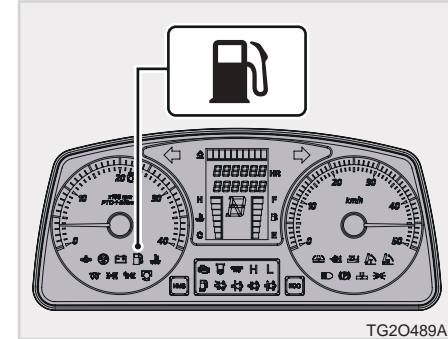

This lamp comes on when the fuel tank is approaching empty. When it comes on, you should add fuel as soon as possible. Driving with this lamp on or with the fuel level below "E" can cause the engine to misfire and damage the engine parts.

### EMISSION WARNING LAMP

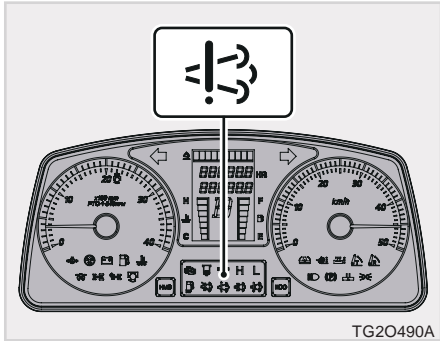

Normally, it comes on and blinks along with the check engine lamp.

If this lamp comes on or blinks, the engine system is malfunctioning. Therefore, stop working and have the system checked.

If you ignore the blinking lamp and keep working without having the system diagnosed and serviced, the engine power can be dropped and its speed can be forcibly lowered to the low idle speed in a certain period of time. Also, the system can be damaged.

### ERROR INDICATOR

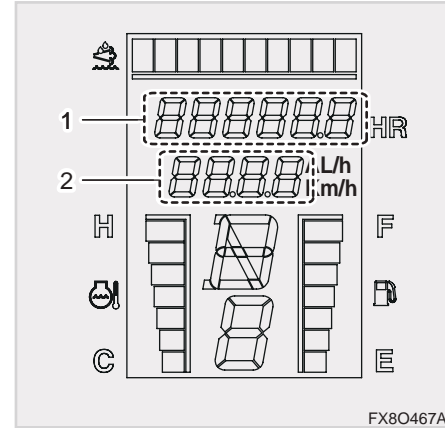

(1) ECU SPN, TCU and General Error Code  
 (2) ECU FMI Error Code

If an error occurs, error code is displayed on the hour meter of the LCD window.

**⚠ WARNING**

- **Contact to local KIOTI dealer.**

### ▶ GENERAL ERROR CODE

NO.	DISPLAY	DESCRIPTION
1	ERR-001	No Signal at TACHO Input
2	ERR-002	No Signal at Water Temp
5	ERR-009	No Signal at HOUR Input

#### NOTE

- Some error codes may not be displayed depending on the model.

### ▶ POWER SHUTTLE CONTROLLER ERROR CODE

NO.	DISPLAY	DESCRIPTION
1	tcu001	Clutch pedal sensor
2	tcu002	Transmission oil temp. sensor

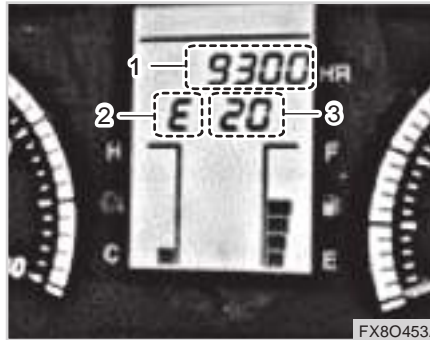

- (1) SPN (Suspect Parameter Number) Code  
 (2) ECU: E  
 (3) FMI (Failure Mode Indicator) Code

ECU SPN code and ECU FMI code are displayed on the LCD windows. When You found these on the LCD, please contact with **KIOTI** dealer.

## OPERATING THE CONTROLS

### [POWER SHUTTLE(PC) MODEL]

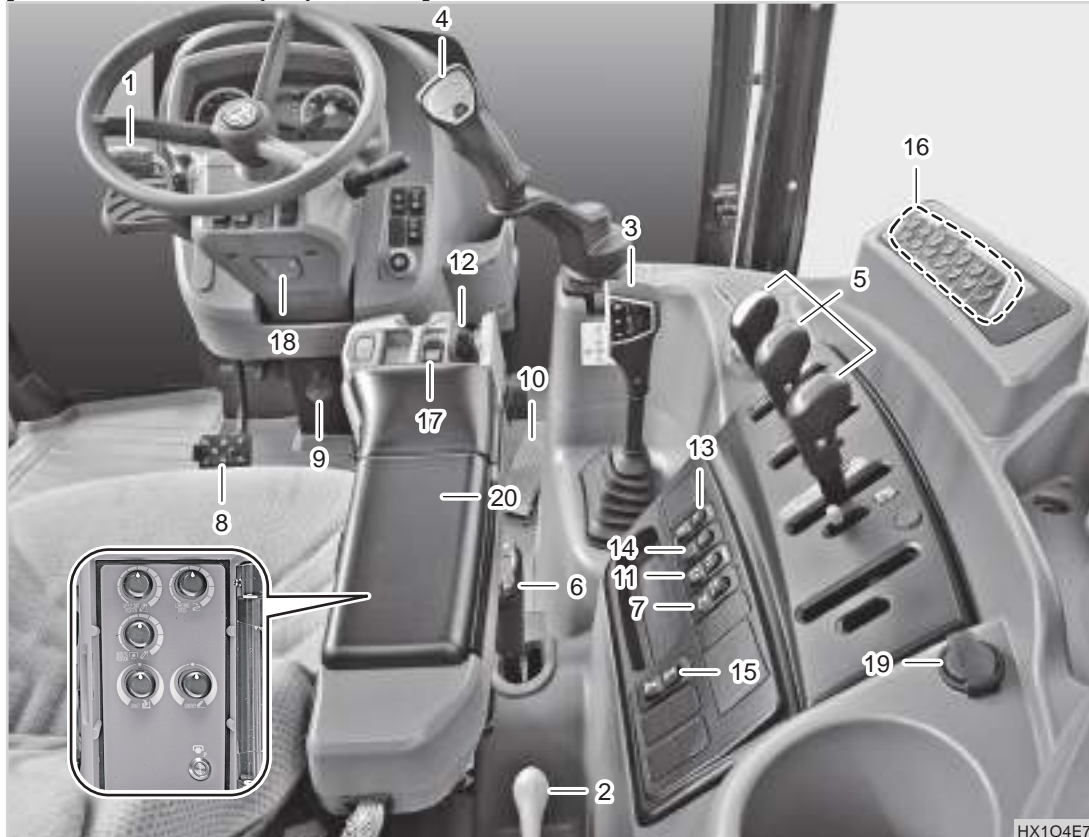

- (1) Shuttle Shift Lever
- (2) PTO Shift Lever
- (3) Main Shift Lever
- (4) Joy-stick Lever
- (5) Double Acting Lever
- (6) Range Shift Lever
- (7) PTO Auto/Manual Switch
- (8) Clutch Pedal
- (9) Steering Column Tilt
- (10) Foot Throttle
- (11) Manual Horizontal Balance Cylinder Control Switch
- (12) Position Control Lever
- (13) Turn Up/Back Up Switch
- (14) Work Mode Control Switch
- (15) 4WD/QT Switch
- (16) Control Panel
- (17) One-touch Up/Down Switch
- (18) Telescoping Lever
- (19) USB Charge Port
- (20) Implement Control Dial Panel

## SHUTTLE SHIFT LEVER



HX10415A

(1) Shuttle Shift Lever  
(F) Forward (N) Neutral (R) Reverse

This lever is used to select forward or reverse driving.

As the transmission structure of this lever is an electro-hydraulic type, it can move in either a forward or reverse direction only by operating the shuttle shift lever without the clutch depressed. Put this lever into the neutral position when the tractor is not driven.

### ⚠ CAUTION

- Reduce the speed before moving this lever since it is very dangerous to switch the driving direction at a high speed.

### HOW TO SWITCH BETWEEN FORWARD DRIVING AND REVERSE DRIVING (P/ SHUTTLE)

- To switch between the forward driving and reverse driving, push the shuttle shift lever forward while lifting it slightly to select forward driving. Pulling it back selects reverse driving.
- If the engine is just started, operate the shuttle shift lever at a low engine speed. When the machine starts to move, depress the accelerator pedal to increase the driving speed.
- There may be a shock from shuttle shifting if the transmission fluid temperature is low. Therefore, be sure to warm up the engine sufficiently before starting off.

## MAIN SHIFT LEVER

- It is possible to operate the shuttle shift lever at a high speed. When pulling the lever backward during forward driving, reverse driving is selected as soon as the machine speed is decreased down to 9 km/h.
- When placing the shuttle shift lever in the neutral position, power is cut off, resulting in decrease of the machine speed and eventually stopping of the machine.

### CAUTION

- **Operating the shuttle shift lever at a high speed can be very dangerous. Make sure to reduce the driving speed sufficiently before operating the lever.**

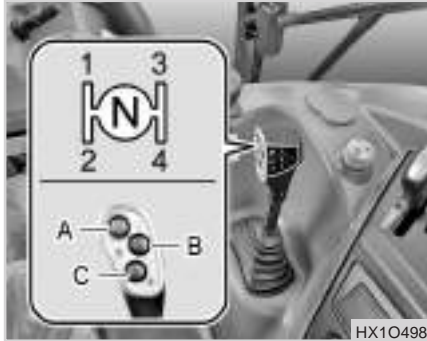

(1) Main Shift Lever (A) Hand Clutch  
(B) High Speed Selection Button  
(C) Low Speed Selection Button

Four speeds can be selected by moving this main shift lever in "H" shaped path. You can shift this lever from the 1st to 4th gears even when the tractor body is moving by disengaging the clutch during driving as these gears are synchromeshed.

In total, 32 forward driving speeds and 32 reverse driving speeds are provided by combination of the main shift lever (2 (Hi/Low) speeds x 4 speeds), range shift lever (4 speeds) and shuttle shift lever. (EU Model)

In total, 24 forward driving speeds and 24 reverse driving speeds are provided by combination of the main shift lever (2 (Hi/Low) speeds x 4 speeds), range shift lever (3 speeds) and shuttle shift lever. (US Model)

## HAND CLUTCH

This functions as the foot clutch pedal. When pressing this button during driving, the main shift lever can be operated. (Without depressing the foot clutch pedal)

## HIGH / LOW BUTTON (POWER SHUTTLE)

You can switch between the high driving speed and low driving speed by pressing this button during driving. The current shifting status can be identified through the HIGH/LOW lamp on the instrument cluster. (When the engine is started, the LOW speed is automatically selected.)



## RANGE GEAR SHIFT LEVER



(1) Range Gear Shift lever  
 (C) Creep Speed      (H) High Speed  
 (L) Low Speed      (M) Mid Speed  
 (N) Neutral

High, mid, low and creep speeds can be selected by the range shift lever. (EU Model)



(1) Range Gear Shift lever  
 (H) High Speed  
 (M) Mid Speed      (L) Low Speed

High, mid and low speeds can be selected by the range shift lever. (US Model)

Make sure to shift the range shift lever after the tractor is completely stopped by depressing the clutch pedal.

If the lever is not moved freely or makes abnormal noise, put the lever into the neutral position, engage and disengage the clutch, and then try to shift the lever.

### ⚠ CAUTION

- Make sure to shift the range gear shift lever with the clutch pedal depressed and the tractor stationary.
- Never put the range shift lever into the high speed position during driving backward as it is dangerous to drive at a high speed.
- The tractor is not braked by depressing the brake pedal without depressing the clutch pedal at a low speed as rotational force of the axle has a major effect at a low speed. Therefore, disengage the clutch before depressing the brake pedal to stop the tractor

Position the creep speed lever in the "H" position in normal conditions, and shift it to the "L" position only when necessary.

When the creep speed is selected, the

rotational force of the axle has major effect on the tractor. (Mechanical)

Misuse of this lever can result in malfunction or damage. Therefore, note the followings:

**1. It is recommended to use the creep speed under the following conditions**

- When cultivating a field deeply or shallowly
- When it is not possible to work at the standard speed due to hard soil
- When transplanting
- When working with a trencher. (Agricultural)
- When loading or unloading during driving

**2. It is recommended not to use the creep speed under the following conditions**

- When getting out of a puddle in muddy area
- When towing or trailing

- When working with a loader
- When doing public works

**3. Precautions for creep speed**

- Make sure to shift with the clutch pedal fully depressed.
- Start off the tractor with the parking brake released.
- Depress the brake pedal after disengaging the clutch to stop the tractor.

**CAUTION**

- **The tractor is not braked by depressing the brake pedal firmly without depressing the clutch pedal at the creep speed as rotational force of the axle has a major effect at the creep speed.**

**PTO SHIFT LEVER**



(1) PTO Shift Lever

This lever is used to shift to one of the 3 PTO speeds as follow:

(rpm)		
1st	2nd	3rd
540	750	1,000

※ Engine rpm: 2,200

### ⚠ CAUTION

To avoid personal injury :

- Disengage PTO, stop engine, and allow all rotating components to come to a complete stop before connecting, disconnecting, adjusting, or cleaning any PTO driven equipment.

## PTO SELECTION LEVER

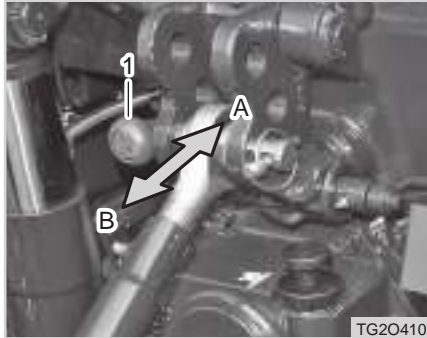

(1) PTO Selection Lever  
(A) Independent PTO  
(B) Ground Speed PTO

You can select independent PTO operation or ground speed (by transmission speed ratio) PTO.

To select an operating mode; stop the tractor completely, reduce the engine speed to idle, turn PTO switch to "OFF" position, put all shift lever on neutral position and now select the PTO operating mode.

## INDEPENDENT PTO

The independent PTO mode is used for normal PTO operations. It operates continuously at a constant speed, independent of the transmission speed selections. The PTO shaft turns in a clockwise direction. (As viewed from the rear of the tractor)

## GROUND SPEED PTO

The PTO speed will be proportional to the tractor speed. The PTO shaft will stop when the tractor is stopped. It is important to note the PTO shaft will rotate in the opposite direction when the tractor is in reverse.

## PTO GROUND SPEED RATIO

Shift Model	1st	2nd	3rd
US	5.6	7.6	-
EU	5.6	7.6	10.4

※ Rear wheel contrast

## CLUTCH PEDAL



(1) Clutch Pedal

Make sure to depress the clutch pedal to its end. To start off smoothly, put the main and range shift levers into the proper positions and release the clutch pedal slowly.

It is not necessary to depress the clutch pedal when shifting shuttle lever as the electro-hydraulic clutch system is applied to this tractor.

### ⊕ IMPORTANT

- Never put your foot onto the clutch pedal during driving. There can be a malfunction in the hydraulic clutch.
- Be sure to depress the clutch pedal fully when shifting main gear or range gear.

## BRAKE PEDAL

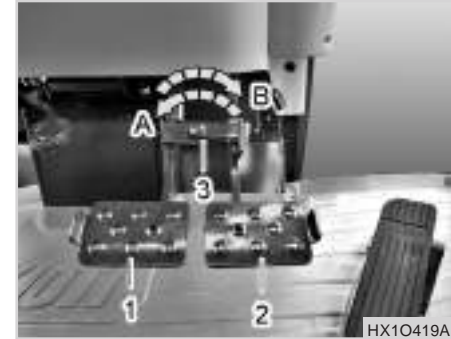

(1) Brake Pedal (L)      (2) Brake Pedal (R)  
 (3) Pedal Interlock  
 (A) Unlock                  (B) Lock

1. Make sure to link the left and right brake pedals as shown in the figure while driving on a road. The tractor can roll over if depressing only one brake pedal at a high speed.
2. To make a sharp turn in a work field, disengage the left and right brake pedals to use one brake pedal. Unlock the brake lock, and then turn the steering wheel while depressing the brake pedal on the turning side.
3. Depressing only one brake pedal is

not much effective while the 4WD is activated. (Effective in case of 2WD)

### **⚠ WARNING**

- **Make sure to interlock the brake pedals as an accident, such as rollover or impact, can occur during driving, and entering/exiting field.**
- **The durability of the axle can be deteriorated if only one brake pedal is depressed during the 4WD is activated. It is more effective to use the quick turn function, rather than the brake (one side) pedal, during the 4WD is activated and to use the brake (one side) pedal during the quick turn function is activated.**

## STEERING WHEEL ADJUSTMENT

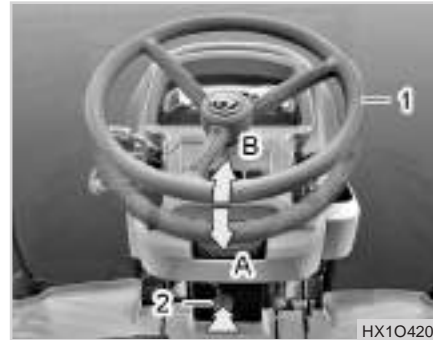

(1) Handle  
(A) Lowering  
(2) Tilt Pedal  
(B) Lifting

The angle of the steering wheel can be adjusted for the driver's comfort. Hold the steering wheel with both hands, depress the tilt pedal lightly and then adjust the position of the steering wheel as desired.

### **⚠ WARNING**

- **Do not adjust the tilt steering while driving.**

## TELESCOPING FUNCTION



(1) Telescoping Lever  
(A) Pull  
(2) Handle

The telescoping lever is used to adjust the height of the steering wheel. With the telescoping lever pulled, pull up or push down the steering wheel to adjust it to the desired height.

## PARKING BRAKE LEVER

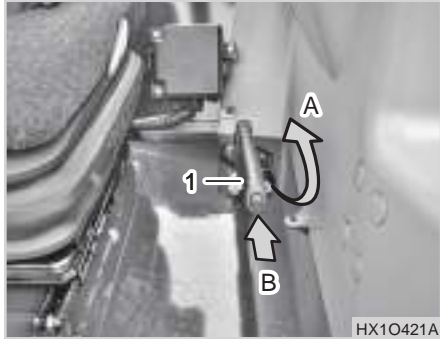

(1) Parking Brake Lever  
(A) Pull (B) Push

To stop the tractor, depress the brake pedal and pull the lever up to apply the parking brake. To engage the parking brake, pull the lever up to "A" position. To release the parking brake, pull up and press the thumb button. Then, while holding the button in, lower the brake lever.

### WARNING

*To avoid possible injury, death or loss of property from a machine runaway :*

- *With the engine off, the tractor may move unexpectedly regardless of the gear shift position.*
  - *Before leaving the tractor, certainly apply the parking brake to prevent machine runaway.*
- ※ *Only power shuttle model.*

### CAUTION

- *If the vehicle is driven with the parking brake partially or completely engaged, it may cause early wear of the brake disc.*

## PARKING LOCK LEVER



(1) Parking Lock Lever

This is a double safety device that forcibly locks the driving gear to prevent a vehicle moving accident that may occur when the parking brake is unintentionally released. Be sure to operate the parking lock lever after applying the parking brake lever to prevent safety accidents.

## FOOT THROTTLE



(1) Foot Throttle

The foot throttle is mainly used during driving on a road while the hand throttle lever is mainly used in a work field.



## HAND THROTTLE LEVER



(1) Hand Throttle Lever

 Slow

 Fast

The hand throttle lever is to control the engine rpm. The engine accelerates to its full speed by pushing the hand throttle lever (  position) completely out while pulling the lever (  position) decelerates the engine.

The hand throttle lever is mainly used while working on a field.

### CAUTION

- Using the hand throttle lever during driving can lead to an accident as it becomes hard to decelerate the tractor rapidly.
- If the engine stalls with the speed control lever engaged, lower and lift the lever again for correct operation.

## PTO MAIN SWITCH

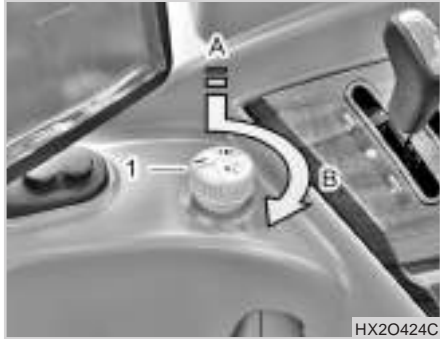

(1) PTO Main Switch  
 (A) Press      (B) Turn

The PTO switch is used to supply power from the tractor to the implement.

Press and turn the knob clockwise to engage the PTO. To disengage the PTO, just push down the knob slightly. Then, the switch knob is returned to its original position.

Make sure to put this switch into the "OFF" position before starting the engine. Otherwise, the engine cannot be started.

The rear PTO rotates at 540 rpm (1st) when the engine speed is approx. 2,115 rpm.

### ⊕ IMPORTANT

- When engaging the PTO, lower the engine speed, engage the PTO, and then accelerate the tractor gradually in order to prevent impact load to the PTO from abrupt operation.

### ⚠ CAUTION

To avoid personal injury and accident :

- Before disassembling or cleaning the PTO system, make sure that the PTO switch is in the "OFF" position, the engine is stopped, and all parts are stopped.
- Always keep the PTO driving part clean. Also, check that the PTO cover is open.
- Disengage the PTO while driving on a road.
- Be careful not to get your hand, foot, cloth, or hair into any driving part while the PTO is in operation. You can be severely injured.
- Make sure that no one is around the tractor and implement while the PTO is in operation.



## PTO AUTO/MANUAL SWITCH



HX104G4A

(1) PTO Auto/Manual Switch

(A) PTO - Auto      (B) PTO - Manual

The PTO main switch must be in the OFF position before starting the engine. Otherwise, the engine will not start. When the PTO Auto/Manual switch is set to the Auto position, the PTO implement only works in the low position. (For example, if the implement is lifted during operation, the PTO will stop.) When the PTO Auto/Manual switch is set to the Manual position, the PTO operates continuously regardless of the position of the implement.

### ⊕ IMPORTANT

- When engaging the PTO, lower the engine speed, engage the PTO, and then accelerate the tractor gradually in order to prevent impact load to the PTO from abrupt operation.

## REMOTE PTO FUNCTION



HX10459A

(1) Remote PTO switch

4

The remote PTO function can be activated by using the remote PTO switch on the back of the tractor under the following conditions. The remote (external) PTO button can be operated with the controller on the armrest.

### 1. Condition:

The buzzer sounds when the main PTO switch is ON, the remote PTO switch is ON, the parking brake switch is ON, and the shuttle lever is in neutral position.



HX104H1A

(1) Remote PTO Button

2. Output:

When the specified conditions are met, the PTO is activated as long as the remote PTO switch on the fender outside is pressed. Pressing the switch for 4 seconds or longer under this condition will keep the PTO shaft rotating even after releasing the switch.

3. Deactivation

While the PTO shaft rotates, it can be deactivated under the following condition:

- 1) The remote PTO switch is pressed once.

**NOTE**

- The PTO is automatically deactivated if the parking lever is released, and the vehicle starts to move while the PTO is being controlled with the remote PTO switch. Therefore, avoid releasing the parking brake or driving the vehicle while controlling the PTO with the remote switch in order to prevent injury.

**DRIVING SELECTION SWITCH**



HX104G5A

(1) Driving Selection Switch  
(A) 4WD (B) OFF

Operate the switch to select 4WD (four-wheel drive) driving mode. Press the top to select 4WD mode, press the bottom to turn it off. Each riding mode has the following features:

SWITCH	TURNING	LAMP
2WD	Normal turning	Lamp OFF
4WD	Normal turning	4WD lamp ON 

**⚠ CAUTION**

- **Do not activate the 4WD function on a paved road or while driving at a high speed. It may cause an unexpected accident.**
- **Before driving at a high speed, confirm that the switch is set in the 2WD position. If driving at a high speed with the 4WD function activated, the tires can be rapidly worn.**

**4WD OPERATION**

The 4WD function is used to increase traction power by driving the front and rear wheels (4 wheels). To engage the 4WD, press the upper section of the 4WD switch. As the 4WD operation is performed by hydraulic pressure, a simple operation of the switch can control it.

The 4WD function is useful under the following conditions:

1. When strong traction force is required in a humid area.
2. When towing a trailer or using a loader.
3. When working on sand.
4. When the tractor is pushed forward by repulsive force from the rotary tiller on hard soil.
5. When tilling a field or moving over a field bank.

**⚠ CAUTION**

**To avoid accidents:**

- **Do not activate the 4WD function while driving on a road. The 4WD should not be used on a paved road as tires can be worn faster.**
- **While the 4WD is engaged, drive the vehicle with low speed as steering and braking characteristics may differ.**
- **The 4WD can be activated even while the vehicle is moving. However, noise or shift shock may occur during 4WD engagement in this case. To ensure safe driving, it is recommended to engage the 4WD after stopping the machine completely.**

### OPERATION/DRIVING RE- SPONSE SETTING BUTTON

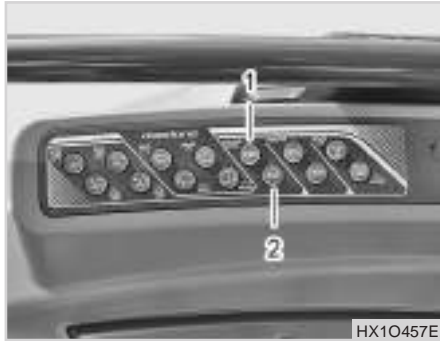

(1) Operation Button  
(2) Driving Button

Press the Operation or Driving button to operate the tractor according to the usage.

#### CAUTION

- **Make sure to press the Operation button before any agricultural work.**

### CALIBRATION BUTTON



(1) Calibration Button

This button is for calibration of shuttle lever and clutch pedal. If any calibration is required please contact **KIOTI** dealer at your convenience.

### BEACON LIGHT BUTTON (IF EQUIPPED)



(1) Beacon Light Button

When driving on the road, be sure to turn on the beacon light to prevent accidents.

## DEFROST BUTTON



(1) Defrost Button

- Use this function when the rear view cannot be secured due to frost or freezing on the rear glass in winter.
- Start the engine and press the upper part of the rear glass defogger switch. Then, the rear glass defogger is activated to defrost the glass in order to obtain clear rear view. (The switch "ON" indicator is illuminated)
- When clear rear view through the rear glass is obtained, press the lower part

tion of the switch to deactivate the defogger. (To prevent battery discharge)

### NOTE

- Once the rear glass defogger is activated, it is automatically deactivated after operation for approx. 15 minutes.
- If the defogger needs to be activated further for clearer rear view, press the switch again.

### CAUTION

- **Avoid using any sharp tool or abrasive cleaner on the rear glass.**
- **When cleaning or working on the rear glass, be careful not to scratch or damage the heated wires on the glass.**
- **Activating the defogger with the engine stopped can discharge the battery. Make sure to start and run the engine before activating the defogger.**
- **Deactivate the defogger after defogging and defrosting operation is completed. If the defogger is kept activated for an extended period of time, it can cause overload to the electric system, leading to damage of its related parts.**



## IMPLEMENT ADJUSTMENT CONTROLLER



(1) Lever Position  
(2) One-touch Switch

Implement operation can be controlled using the function control switch on the armrest, the one-touch switch and the position control lever.

### 1. Position control lever

This lever is used to adjust and maintain the implement in a certain position. Push it down to lower the implement and pull it up to lift the implement.

To set the lever in the parking position, pull it up and move it to the parking position; then, lock it in place with the lock switch.

### 2. One-touch lifting/lowering switch

Press the lifting switch once to lift the lift arm up to the position set by the position control lever. Pressing the lowering switch once lowers the lift arm to the lowest position.

### CAUTION

- **Do not operate the position control lever forcibly as it only requires a slight force to be operated. Otherwise, the lever can be damaged.**

### NOTE

#### <Safety lock>

- To ensure the driver's safety, the implement cannot be lifted or lowered under the following conditions:
  - The implement cannot be lowered by operating the position control lever after the engine is stopped.
  - The implement cannot be moved to the position set by the position control lever after the engine is started even if the position control lever is moved to a different position after the engine is stopped.

#### <Releasing the safety lock>

- To release the safety lock, start the engine and operate the position control lever or press the one-touch lifting/lowering switch.

## HIGH / LOW SELECTION SWITCH



HX1O4H9A

- (1) High/Low Selection Switch  
 (A) High Speed Selection Switch  
 (B) Low Speed Selection Switch

You can switch between the high driving speed and low driving speed by pressing this button during driving. The current shifting status can be identified through the HIGH/LOW lamp on the instrument cluster. (When the engine is started, the LOW speed is automatically selected.)

## ADJUSTING THE IMPLEMENT OPERATION CONTROLLER HEIGHT

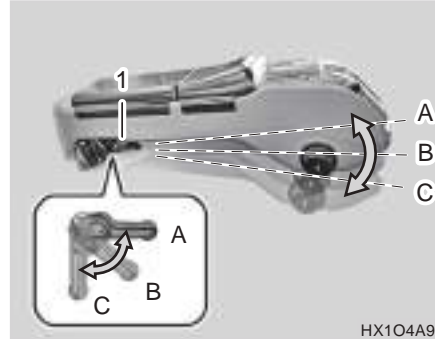

HX1O4A9A

- (1) Position Control Lever  
 (A) High (B) Middle (C) Low

The height of the implement operation controller can be adjusted using its position control lever. The height of the controller can be chosen among the three levels (high, middle and low). To adjust the height, pull up the controller slightly, adjust the height using the lever, and then push down the controller back again.

## IMPLEMENT ADJUSTMENT SWITCH



HX1O4E9B

- (1) Lowering Speed Set Dial  
 (2) Sensitivity Control Dial  
 (3) Upper Limit Position Dial  
 (4) Auto PTO Position Dial  
 (5) Draft Control Dial  
 (6) Remote PTO Switch

The hydraulic system is always running while the engine is in operation, regardless of the gear setting of the clutch. The implement lift is operated by a microcomputer, so be sure to read the following information carefully.

### LOWERING SPEED SET DIAL



Adjusts the lowering speed of the implement.

Turning the dial to the left slows down the lowering speed of the implement. The implement cannot be lowered if the dial is turned all the way to the left. Turning the dial to the right speeds up the lowering speed of the implement.

### SENSITIVITY CONTROL DIAL



Adjusts the reaction speed of the implement in automatic draft mode.

Turning the dial to the left makes the reaction speed of the implement more sensitive and faster. Turning the dial to the right makes the reaction speed of the implement less sensitive and slower.

### UPPER LIMIT POSITION DIAL



Limits the lifting height of the implement during one-touch lifting, turning-linked lifting, and reverse driving-linked lifting operation.

Turning the dial to the left lowers the maximum lifting height of the implement.

Turning the dial to the right increases the maximum lifting height of the implement.



### PTO DISENGAGEMENT POSITION DIAL



Sets the stopping height of the PTO in automatic PTO mode.

### DRAFT CONTROL DIAL



Adjusts the draft power in automatic draft mode. Once the draft power has been set to the desired level, the implement maintains the set level of draft power.

Turning the dial to the left lowers the set draft power and the plowing depth is set shallow.

Turning the dial to the right increases the set draft power and the plowing depth is set deep.

### REMOTE PTO SWITCH

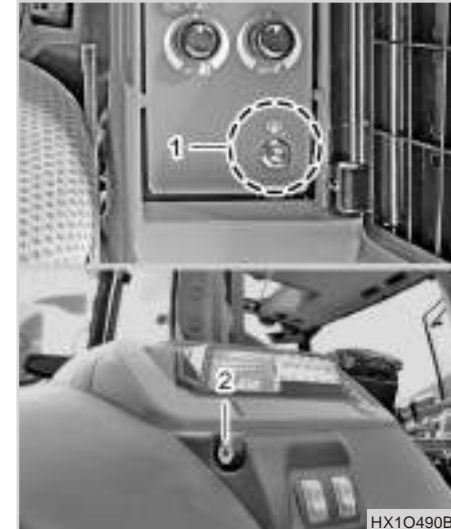

(1) Remote PTO Switch

(2) Remote PTO Operation Switch

After the external PTO switch is turned ON, the PTO power can be activated using the remote PTO activation switch mounted on the back of the tractor under the specified condition. (Refer to Page 4-39, "Remote PTO function.")

## DIFFERENTIAL LOCK PEDAL (REAR)

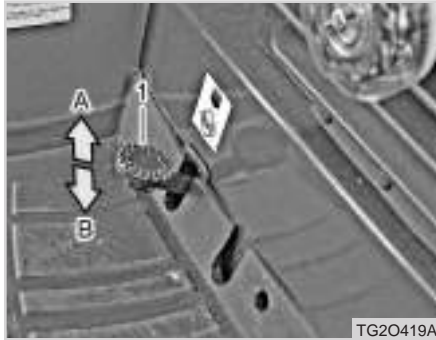

(1) Lock Pedal  
 (A) Release to Disengage  
 (B) Depress to Engage

The differential lock is to secure the differential system and keep the wheel rotation on both sides the same in order to enhance the traction of the rear axle.

Depressing the pedal engages the differential lock while releasing the pedal disengages the differential lock.

Use this system under the following conditions.

1. When any wheel slips and the tractor does not move in the field.
2. When it is hard to escape a paddy field.

### ⚠ CAUTION

- **The differential lock should be engaged only while the driving clutch is engaged. If the differential lock pedal does not move when depressing it, try to depress it again after releasing it.**
- **When engaging the differential lock, reduce the engine speed. After engaging it, accelerate the tractor.**
- **Make sure to set the steering wheel in the straight ahead position while the differential lock is in use. Otherwise, the differential system can be damaged.**

## SEAT ADJUSTMENT SEAT SLIDING



(1) Seat Adjustment Lever

To adjust the seat position, pull the lever (1) to left under the front of the seat, slide the seat to the desired position, and then release the lever.

Make sure that the seat is firmly fixed by moving it gently after adjustment.

**⚠ WARNING**

- *Never Leave the driver's seat while the engine running.*
- *Before leaving the seat, be sure to turn off any implements which are equipped with rotating blades such as rotary tiller, rotary cutter, mid/rear mower, snow blower, etc. and turn off the engine.*

**⚠ CAUTION**

- **Do not put a hand between the seat and the slides when adjusting the seat position. You can get injured unexpectedly.**

**SEATBACK RECLINING**

(1) Seatback Adjustment Lever

To change the seatback angle, raise the lever (1) on the left of the seat. Then, adjust the seatback angle with the lever pulled. Release the lever after adjustment. Make sure that the lever is returned and the seat is firmly fixed after adjustment.

**SIDE-TO-SIDE ROTATION FUNCTION**

(1) Rotation Adjustment Lever

You can pull the lever to adjust the seat side to side.

### ADJUSTING ARMREST ANGLE



HX1O4B7A

(1) Angle Adjustment Wheel

The angle of the armrest can be adjusted by turning the angle adjustment wheel which is located under the left-hand armrest.

### ADJUSTING THE HEADREST HEIGHT



HX1O4B8A

(1) Headrest

The height of the headrest can be adjusted easily by pulling it up or pushing it down.

### ADJUSTING THE LUMBAR SUPPORT

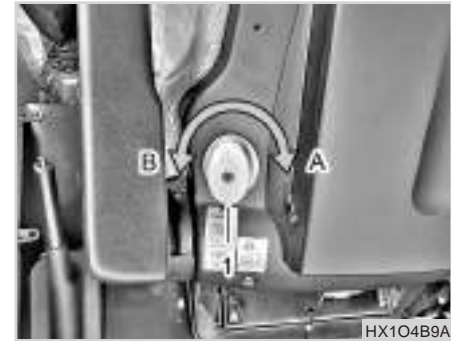

HX1O4B9A

(1) Lumbar Support Control Lever  
(A) Convex (B) Concave

The lumbar support is installed within the seatback cushion. According to the body shape of the operator, turn the lumbar support control lever on the back of the seatback clockwise to make the lumbar support in the seatback convex, and turn it counter-clockwise to make the lumbar support concave.

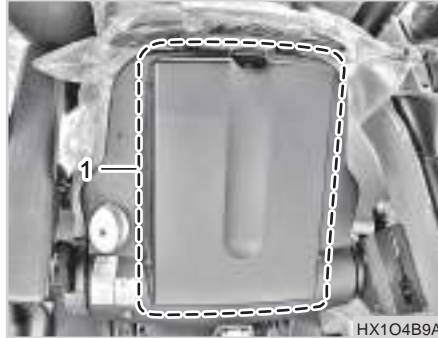
**DRIVER'S SEAT'S STORAGE BOX***(1) Storage Box*

The storage box is mounted on the back of the seatback, and it has a spring-loaded cover which closes automatically when released.

**SEAT BELT***(1) Seat Belt*

The seat belt is self-retracting type. Make sure to fasten the seat belt before driving.

**JOYSTICK LEVER***(1) Joystick Lever*

This joystick lever is used mainly to operate the front end loader which attached to the tractor.

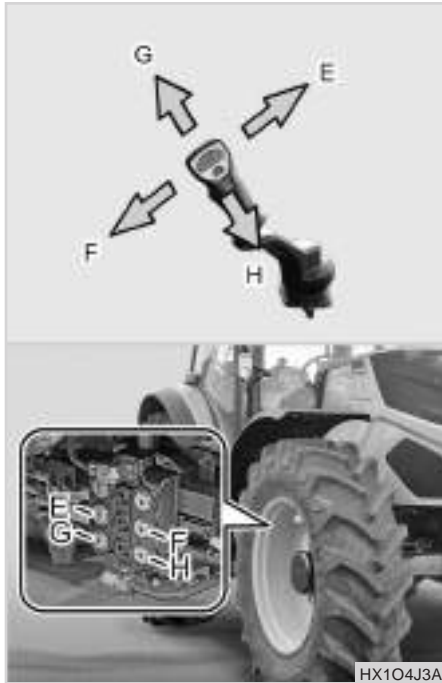

(E) Bucket Roll Back (F) Bucket Dump  
(G) Boom Down (H) Boom Up

The vertical movement of the bucket and boom can be controlled by the lever (↕↕).

E		Bucket Down	F		Bucket Up
G		Boom Down	H		Boom Up

## HORN SWITCH



(1) Horn Switch

The horn switch can be operated without the key inserted. Pressing this switch sounds the horn.

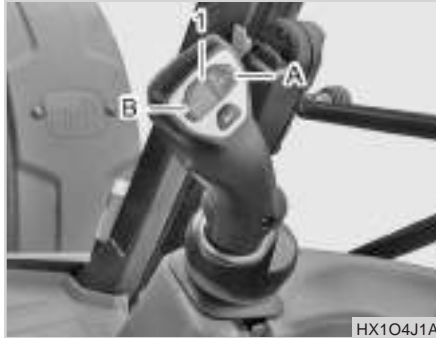
**HIGH / LOW SELECTION SWITCH**

- (1) High/Low Selection Switch  
 (A) High Speed Selection Switch  
 (B) Low Speed Selection Switch

You can switch between the high driving speed and low driving speed by pressing this button during driving. The current shifting status can be identified through the HIGH/LOW lamp on the instrument cluster. (When the engine is started, the LOW speed is automatically selected.)

**DOUBLE ACTING LEVER**

- (1) Double Acting Lever (Self-return type)  
 (2) Double Acting Lever (Detent type)  
 (3) Lock Lever  
 (A) Port A                      (B) Port B  
 (C) Port C                      (D) Port D  
 (E) Port E                      (F) Port F

This lever is used to control a auxiliary hydraulic implement installed to rear.

Lowering the lever supplies hydraulic fluid to Port "B", while raising it supplies hydraulic fluid to Port "A".

See chapter 5, "Operation" for details.

## CABIN SYSTEM INTERIOR DEVICES

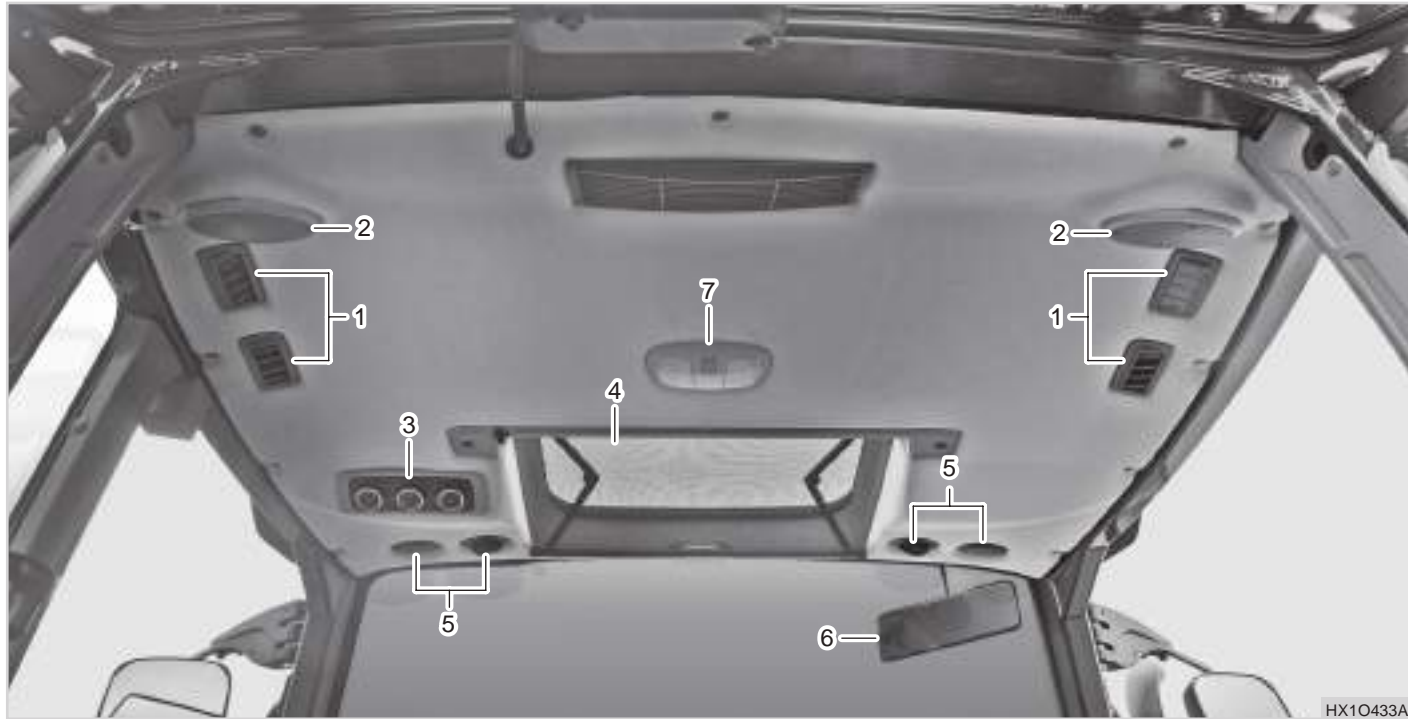

(1) Air Grill  
(2) Speaker  
(3) Heater/Air Conditioner Switch

(4) Sunroof Screen  
(5) Air Inlet  
(6) Room Mirror

(7) Room Lamp

HX10433A



## EXTERIOR DEVICES

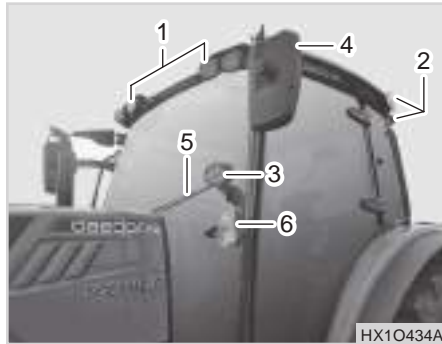

- (1) Work Light (FF)      (2) Work Light (RR)  
 (3) Work Light        (4) Rearview Mirror  
 (5) Wiper                (6) Turn Signal Lamp

1. The cabin is designed optimally for the driver's comfort and convenience.
2. This tractor has wide windows as well as outside rearview mirrors on both sides to provide a clear and wide rear view.
3. The cabin can be kept comfortable and pleasant by operating the air conditioner and heater.

4. The cabin structure is safe as it is verified by the ROPS (Roll Over Protection Structure) test. However, make sure to fasten the seat belt for best protection.

## ENTRANCE



- (1) Door Handle

- Pull the handle forward to open the door. The door can be locked by turning the lock cylinder on the outer side of the door with the ignition key.

## UNLOCKING THE DOOR



(1) Door Lever

Push the lever to open the door in the cabin.

## REAR WINDOW

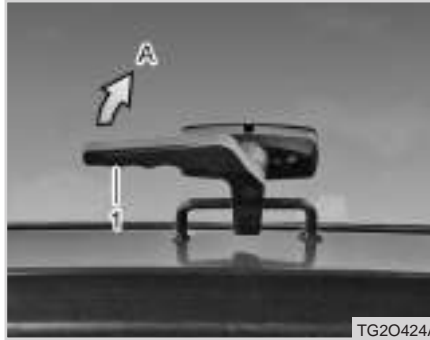

(1) Handle of Rear Window  
(2) Button

Press the button on the rear window handle lightly to open the rear window in the cabin.

To close it, hold the handle and pull it gently.

### WARNING

- **Never drive the tractor with the door open. An accident can occur.**

### WARNING

- **The rear window may not be opened due to an implement. Make sure to check if there is enough space to open the window to prevent damage and breakage by an implement.**

## WORKING LIGHT



- (1) Working Light Switch (Front)
- (2) Working Light Switch (Auxiliary work light)
- (3) Working Light Switch (Rear)
- (2) Working Light Switch (Side)

The work lights are installed on the roof front, side, rear and the top of the combination lamp, and the operation button is installed on the right panel of the cabin driver's seat. To turn on the work light, press the appropriate work light switch. The ignition key switch must be in the "ON" position at this time.

### ⚠ WARNING

- Do not drive the tractor on a road with the work lights ON at night.
- The approaching or following vehicle's visibility can be disturbed, which is very dangerous for both drivers. In this case, use the hazard lamps.

## ESCORT FUNCTION

When stopping the engine with the work lamps illuminated after (night) work, the work lamps keep illuminated for 30 seconds to secure the operator's visibility for safety.

## WIPER



- (1) Wiper Operating Switch (Front)
- (2) Wiper Operating Switch (Rear)
- (3) Washer Switch (Front)
- (4) Washer Switch (Rear)

1. Press the button marked (wiper) to turn on the power.
2. When the washer button is pressed while the ignition key switch is in the "ACC" or "ON" position, washer fluid is sprayed through the nozzle of the wiper.

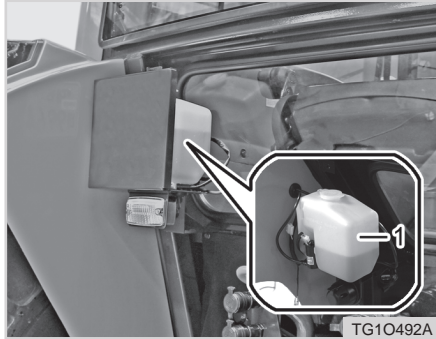

(1) Washer Fluid Tank

3. The washer fluid for the windshield is installed on the rear left side outside the cabin.

### ⚠ WARNING

- **Normal water can be used as the washer fluid, but it is recommended to use the washer fluid made exclusively for vehicles. Especially, make sure to use seasonal washer fluid in winter.**
- **The washer fluid motor can be damaged if you are trying to spray the washer fluid when its tank is empty. Therefore, make sure to check the fluid level before driving.**
- **Spray enough washer fluid and operate the wiper if there is dirt on the window. When operating the wiper while it is frozen to the window, its fuse can be blown. In this case, operate the wiper after increasing the cabin temperature enough to defrost the wiper.**

## ANTENNA



(1) Antenna

Check the contact and angle of the antenna in case of poor signal reception.

## ROOM LAMP

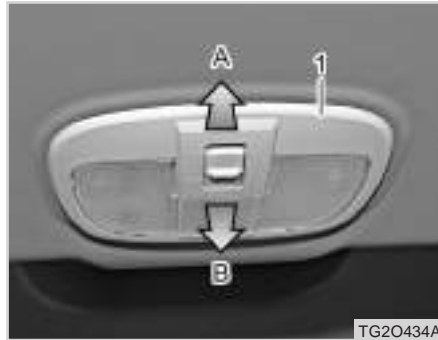

TG2O434A

(1) Room Lamp

(A) ON

(B) OFF

(C) Auto ON

Push the interior lamp lever to the ON position to turn on the interior lamp. When opening the left-hand door with the interior lighting lever in position "C," the interior lights automatically turn off.

 **CAUTION**

- **The room lamp can be operated without the key inserted. However, turning it on for an extended period of time can discharge the battery.**

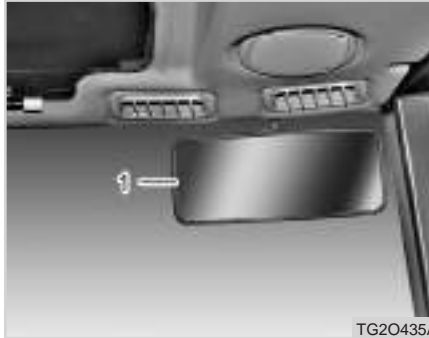
ACCESSORY  
INSIDE REAR VIEW MIRROR

TG2O435A

(1) Inside Rearview Mirror

The cabin is equipped with the inside rearview mirror for the driver's convenience.

Adjust the angle of the mirror before driving to secure for a clear rear view.

POWER SOCKET AND USB  
CHARGING PORT

HX1O4C6A

(1) Power Socket

(2) USB Charge



HX1O4C6A

The power socket (1) can be used as a power supply for an external device. It can be used while the ignition switch is in the ON position or the engine is running.

An external device with a USB port can be charged using the USB charging port (2), which is located on the right side of the driver's seat.

### 3-PIN POWER SOCKETS & BANANA JACKS



(1) 3-Pin Power Socket  
(2) Banana Jacks

The 3-pin sockets are located on the left and right sides behind the driver's

seat. They can be connected to a trailer to be used as a power source for various indicators, side lamps, brake lamps, and fog lamps.

The banana jacks can be used as a power source for a device using (+) & (-) poles for power supply.

**CUP HOLDER AND STORAGE***(1) Cup Holder & Storage*

There are storage areas and cup holders above the left and right lever guides in the cabin.

**REFRIGERATOR / HEATING CABINET***(1) Refrigerator / Heating Cabinet*

There is the refrigerator/heating cabinet which is located inside left fender cover in cabin to storage a drinking water and beverage. (Ref to the refrigerator/heating cabinet owner's manual)

**SUNSHADE***(1) Sunshade*

To block the sunlight coming in through the sunroof, pull out the sunshade and fix it with its hook. When it is no longer needed, unhook and store it.

## SUNROOF

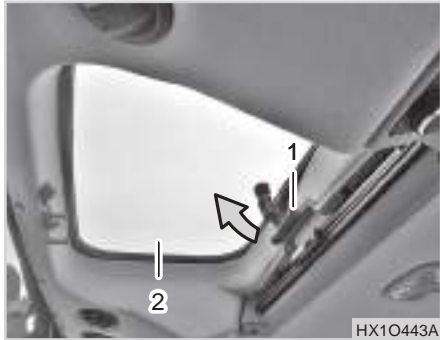

(1) Sunroof Lever (2) Sunroof

1. Use the sunroof to let the fresh air flow into the cab.
2. To open the sunroof, press the button on the lever. Then, the sunroof is smoothly opened by its gas cylinder.
3. After letting in fresh air, pull the lever gently to close the sunroof.
4. When you open and close it, do not apply excessive force on it.

## EMERGENCY HAMMER (ONLY EU MODEL)



(1) Emergency hammer

Emergency Hammer is equipped For Emergency situation like overturn.  
Use this hammer to break the glasses for the escaping from Vehicle.



## HEATER AND AIR CONDITIONER



- (1) Fan Speed Control Dial  
 (3) Temperature Control Dial  
 (5) Recirculation Button

- (2) Vent Mode Control Dial  
 (4) Air Conditioner Switch

The air conditioner should be operated with the engine running.

**⚠ WARNING**

- **Do not leave a child alone in the cabin. His/her health can be threatened as internal temperature rises rapidly in hot weather or on a sunny day.**
- **Use the fresh air mode in normal conditions and use the air recirculation mode only if necessary. Continued operation of the air recirculation mode can cause the inside to become stuffy, causing headaches, drowsiness, or frost on the windows. Do not operate the recirculation mode for an extended period of time.**

## FAN SPEED CONTROL DIAL



4

The fan speed for the heater and air conditioner can be adjusted in four positions.

### AIR CONDITIONER SWITCH









Press it to activate the air conditioner and press it again to deactivate the air conditioner.

The heater can be operated by the temperature control switch and fan speed control switch.

### VENT MODE CONTROL DIAL



-  : When the vent mode control dial is turned to the (  ) position, air comes out from the 4 vents on the left and right.
-  : When the dial is turned to the Bi-level (  ) position, air comes out from 4 vents in the front and 4 vents on the left and right.
-  : When the dial is turned to the Defrost (  ) position, air comes out from 4 vents in the front to defrost the windshield.

### TEMPERATURE CONTROL SWITCH

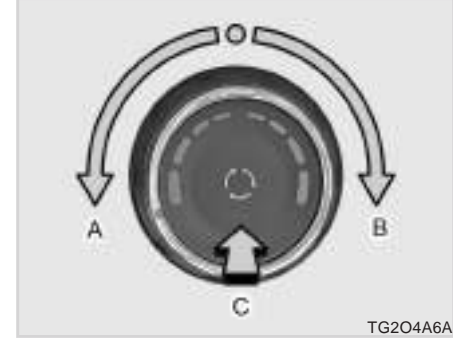

(A) Cooling  
(C) Recirculation

(B) Heating

Use this dial to obtain the desired temperature. Turn it to the right (red) for warm air and to the left (blue) for cool air.

The temperature control dial only controls the blower speed of the air passing through the heater or the A/C. Therefore, if setting it to high temperature with the A/C on, the A/C deteriorates.

Press the recirculation button to block the air from outside. In the recirculation mode, the A/C cools the air inside the cabin only (and the heater core heats the inside air only), enabling rapid cooling and heating. This mode can be used to block dust, odor or gas from the outside as well.

However, as fresh air cannot be introduced into the cabin, and the cabin is not ventilated in this mode, the air quality in the cabin can be degraded. Therefore, make sure to use the fresh air mode or open the window occasionally.

 **CAUTION**

- **After parking the tractor under direct sunlight for an extended period of time, open all the windows to remove hot air in the cabin and operate the A/C.**
- **Keep the windows closed while the A/C is in operation for effective operation.**
- **Turn off the air conditioner for better engine power when the work load rapidly increases.**
- **When the tractor is stationary and being used in high load work, reduce the A/C operation period as the engine may be overheated.**
- **If cold air does not come out from the vents during long hours of driving, turn off the air conditioner, set the fan speed control dial to the 4th speed, drive for 5 to 10 minutes, and then turn on the air conditioner.**

 **CAUTION**

- **Make sure you operate the air conditioner once or twice a month in winter season to prevent refrigerant leakage and facilitate the compressor lubrication for durability of the A/C components.**

### AIR CONDITIONER MAINTENANCE

Make sure to follow the instructions below to keep the air conditioner in the best condition :

#### 1. Operation in winter season :

During the winter time, run the air conditioner once or twice every month to prevent refrigerant leakage and corrosion in the air conditioner system and to facilitate oil circulation in the compressor in order to prevent malfunction.

The A/C does not operate when the air temperature is below 2°C. Therefore, warm the inside air by operating the heater in order to be able to operate the A/C.

#### 2. Air conditioner condenser care:

If there is foreign material in the A/C condenser and engine radiator, their cooling performance may be deteriorated. Therefore, always keep them clean for their optimal cooling performance. When cleaning the core of the condenser, use a soft brush and water carefully to avoid bending the cooling fins.

#### 3. Operation in summer season :

Make sure to check the tension of the A/C belt before using the A/C frequently.

#### CAUTION

- The A/C system is charged with new refrigerant that does not destroy the ozone layer. Be careful when servicing the A/C system.
- Do not use unspecified refrigerant and compressor oil, or the air conditioner system could be seriously damaged.
- The performance of the A/C becomes poor when the refrigerant is insufficient. However, charging the air conditioner with excessive refrigerant affects its performance negatively. Therefore, have the system checked by a KIOTI Dealer if malfunction is found.

#### CAUTION

- A/C system uses new refrigerant R-134A. the use of the wrong refrigerant can cause a malfunction of the system such as compressor failure. Be sure proper refrigerant is used prior to charging the system.
- Water in the A/C system can cause a cooling malfunction and damage cycle parts.
- Insufficient amount of oil in the compressor will cause poor lubrication and compressor failure.
- Excessive amounts of oil will cause a cooling malfunction.
- Refrigerant and compressor oil levels should be checked or replaced if the following occurs:
  - Refrigerant or oil leaks from A/C system
  - Serious refrigerant leaks
  - After repair of A/C system or part replacement

### ⚠ WARNING

- *Have the air conditioner serviced by a qualified service personnel. If it is serviced by an unqualified person, he/she can be injured by the refrigerant under high pressure.*

### A/C REFRIGERANT INSPECTION

If the refrigerant is insufficient, A/C performance becomes inefficient. Also overcharging has a bad effect on the system. If malfunction is detected, have it serviced at a local KIOTI dealer.

Item	New Refrigerant	Compressor Oil
Type	R-134a	Pag oil
Charging amount	0.9 kg	265 cc

### ⚠ WARNING

- *If you sleep with the air conditioner or heater in operation, you may be suffocated to death.*
- *If keeping the A/C on for an extended period of time, inside air can become impure. Therefore, draw outside air and ventilate the cabin regularly.*

### 7-PIN POWER OUTPUT SOCKET

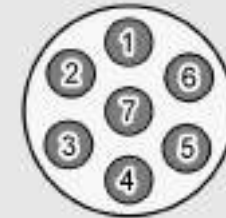

HX1O445A

(1) Power Connector

The 7-pin socket is installed on the rear left side of the tractor.

This supplies power to the brake lamps, turn signal lamps, and position lamps of the trailer.

## TIRES, WHEELS AND BALLAST GENERAL TIRE INFORMATION

No	Circuit	Color of wire
1	Earth	EW
2	Tail lamp and license plate lamp	Br
3	Left turn signal	G
4	Stop	R
5	Right turn signal	Y
6	Position Lamp	B
7	Spare	L

### ⚠ WARNING

- *When driving on a road with an implement which has exterior lamps, such as a trailer, make sure to turn on those lamps by connecting them to the 7-pin socket in order to prevent an accident.*
- *Make sure to check for proper operation after connecting the 7-pin socket to the trailer. It may not operate depending on the trailer specifications. Consult your local KIOTI Dealer for this issue.*

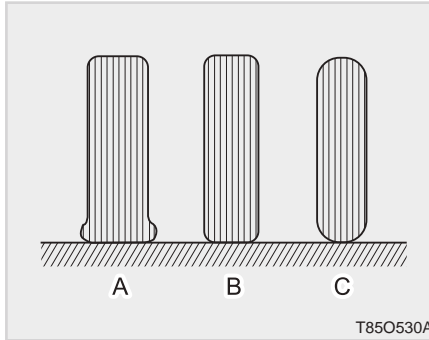

(A) Insufficient  
(B) Standard  
(C) Excessive

Though the tire pressure is factory-set to the prescribed level, it naturally drops slowly in the course of time. Thus, check it everyday and inflate as necessary.

### ⚠ WARNING

- *Do not use tires larger or smaller than specified.*

### ⚠ WARNING

- *Do not disassemble or assemble the tire. If it is necessary to disassemble/assemble the tire, let a qualified service person perform the work.*

## INFLATION PRESSURE

Always maintain the proper tire inflation pressure. Make sure the tire pressure does not exceed the pressure recommended in the manual.

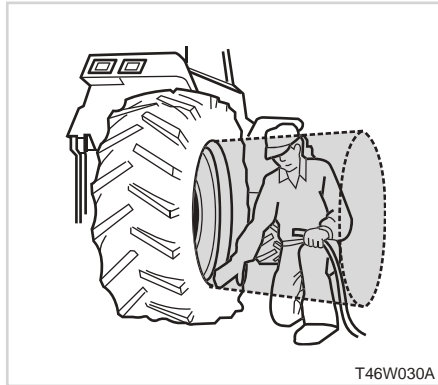

T46W030A

### **⚠ WARNING**

- Use caution when inflating or checking air pressure.

Class	Tire Sizes	Inflation Pressure
Front	12.4-24	2.2 kg/cm <sup>2</sup> , 216 Kpa , 31 psi
Rear	18.4-30	1.7 kg/cm <sup>2</sup> , 165 Kpa , 24 psi
Front	13.6-24	2.2 kg/cm <sup>2</sup> , 216 Kpa , 31 psi
Rear	18.4-34	1.6 kg/cm <sup>2</sup> , 157 Kpa , 23 psi
Front	380/85R28	1.6 kg/cm <sup>2</sup> , 157 Kpa , 23 psi
Rear	460/85R38	1.6 kg/cm <sup>2</sup> , 157 Kpa , 23 psi

\*AG : Agricultural Tire

### **📖 NOTE**

- Keep the front tire pressure to maximum when using the front end loader or front suitcase weights.
- If tires with a different size from the ones already in use are installed, contact the **KIOTI** dealer for the front/rear wheel speed ratio. Improper front/rear wheel speed ratio can result in excessive wear of the tires.

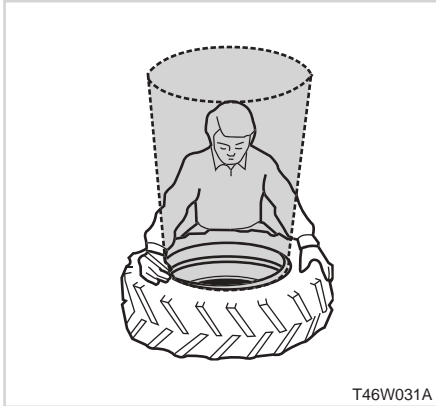

**⚠ WARNING**

- *Do not weld or apply heat to the tire rim or disc. The tire can explode due to the rapidly increased pressure in the tire.*
- *Check tires for inflation pressure, damage, deformation, and excessive wear on lug and damage of rim and disc. Also check if wheel bolts, rim bolts, and nuts are loose.*

**TREAD**

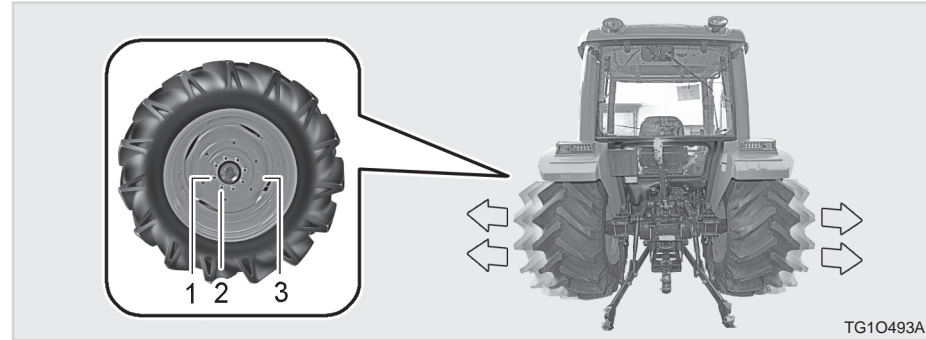

(1) Bolt

(2) Rim Bolt

(3) Rim

The rear axle tread width are adjustable by changing the installation of the tire (together with rim) to the disk, to suit the type or condition of work.

**⚠ WARNING**

- *The front wheel tread width on tractors equipped with front loader must not exceed 69.5 in. (1.77 m).*



 **WARNING**

*Never operate tractor with a loose rim, wheel, or axle.*

- *Always tighten nuts or bolts to the specified torque.*
- *Make sure to frequently check that all these parts are firmly tightened.*
- *Make sure to perform inspection daily.*

in. (mm)

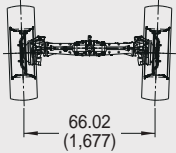
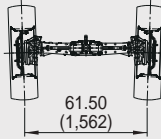
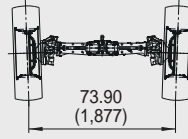
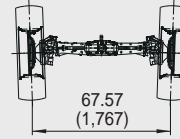
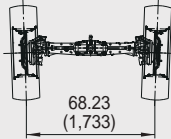
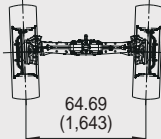
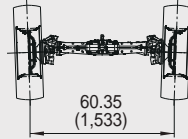
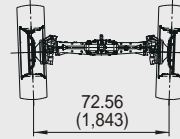
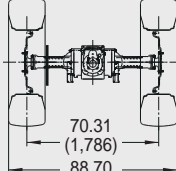
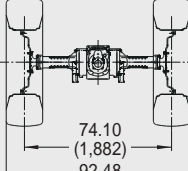
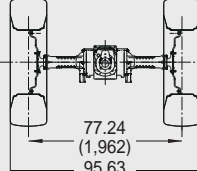
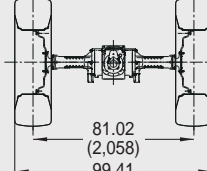
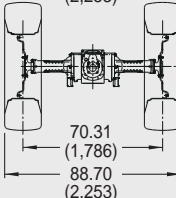
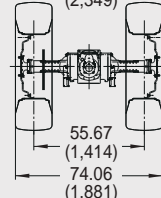
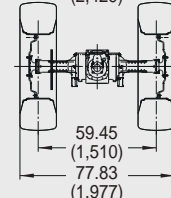
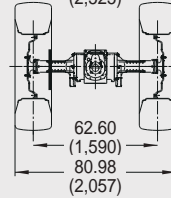
STANDARD		ADJUSTMENT RANGE			
Front (13.6 - 24)	 66.02 (1,677)	 61.50 (1,562)	 73.90 (1,877)	 67.57 (1,767)	 68.23 (1,733)
		 64.69 (1,643)	 60.35 (1,533)	 72.56 (1,843)	
Rear (18.4 - 34)	 70.31 (1,786) 88.70 (2,253)	 74.10 (1,882) 92.48 (2,349)	 77.24 (1,962) 95.63 (2,429)	 81.02 (2,058) 99.41 (2,525)	
		 70.31 (1,786) 88.70 (2,253)	 55.67 (1,414) 74.06 (1,881)	 59.45 (1,510) 77.83 (1,977)	 62.60 (1,590) 80.98 (2,057)

HX104H4A

**Tightening torque**

Wheel nut	Rim bolt
28 ~ 32.5 kgf·m 274.6 ~ 318.7 N·m	28 ~ 34.0 kgf·m 274.6 ~ 333.4 N·m

**▲ WARNING**

- *Use tires approved by KIOTI only.*
- *Assemble the tire as shown in the figure.*
- *Contact your local KIOTI Dealer if it is necessary to change the tire specification or installation method.*

**WHEEL INSTALLATION DIRECTION**

For agricultural tires, make sure to install them with their arrow marks on their side pointing the front driving direction.

The tire is correctly installed if the tread mark "V" on the ground is shown correctly, not up side down, while the tractor is moving forward.

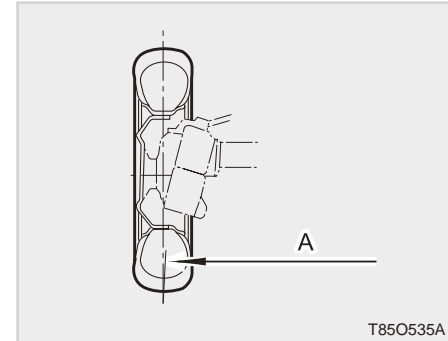
**WHEEL TORQUE AND DIRECTION  
FRONT WHEEL INSTALLATION  
PATTERN**

(A) Tread

Front tread width can not be adjusted. If it is necessary to adjust it, contact your local **KIOTI** Dealer.

If it is damaged by unapproved modification, it will not be covered by warranty.

**Tightening torque of wheel bolt (nut)**

17~19 kgf·m  
166.7~186.3 N·m

**⚠ WARNING**

- *Use tires approved by KIOTI only.*
- *Assemble the tire as shown in the figure.*
- *Contact your local KIOTI Dealer if it is necessary to change the tire specification or installation method.*

**REAR WHEEL INSTALLATION PATTERN**

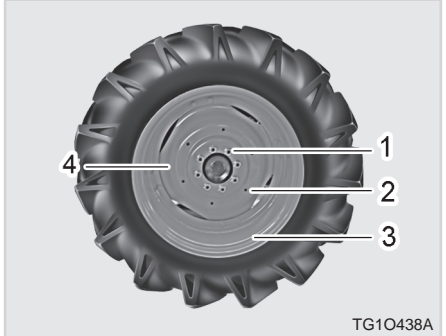

(1) Wheel Nut                      (2) Rim Bolt  
(3) Rim                                (4) Disc

The rear axle tread width are adjustable by changing the installation of the tire (together with rim) to the disk, to suit the type or condition of work.

**ADDITIONAL WEIGHT(IF EQUIPPED)  
ADDITIONAL FRONT WEIGHT**



(1) Additional Front Weight

If the loader is not installed, attach a weight to the front frame of the tractor as a safety measure.

If a heavy implement is installed at the rear or when towing a heavy trailer, the front wheels may be lifted. Add sufficient weight to keep steerability and to prevent rollover.

If sufficient weight, such as front loader, is applied to the front wheels, remove the extra front weight.

If the front tires are excessively loaded, it becomes hard to steer the tractor, the tires can be worn faster and the durability of the front axle can be deteriorated.

### COMPONENTS FOR ADDITIONAL FRONT WEIGHT

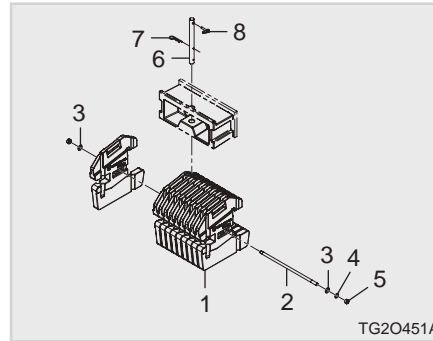

- (1) Weight                      (2) Bolt  
 (3) Plain Washer              (4) Spring Washer  
 (5) Nut                          (6) Weight Lock Pin  
 (7) Clip Pin                      (8) Lift Rod Lock Pin

When installing or removing a weight, always check the tire inflation pressure and adjust it as necessary.

The front weights are available at the **KIOTI** Dealer. For required number of weights, consult your local **KIOTI** Dealer.

Model	Max. load
ALL	1,102 lbs (500 kg) (50 kg x 10 Pieces)

#### CAUTION

- Additional weight might be needed for transporting heavy implements.
- Reduce the speed regardless of additional weight when driving on a bumpy or rough road with the implement lifted. The tractor can roll over.

#### IMPORTANT

- Attach only required amount of weight. Otherwise, the life of the axle or wheel can be shortened.

### ADDITIONAL REAR WEIGHT(IF EQUIPPED)

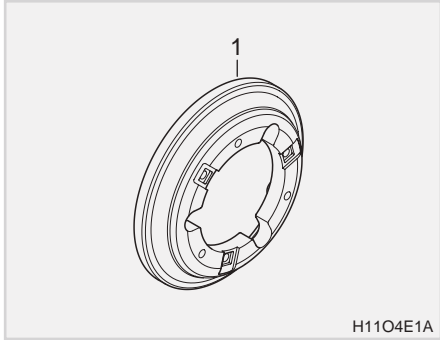

H1104E1A

(1) Rear Weight

The rear weight is used to maximize the traction of the tractor by increasing the grip of the rear wheels when using a heavy trailer or plow.

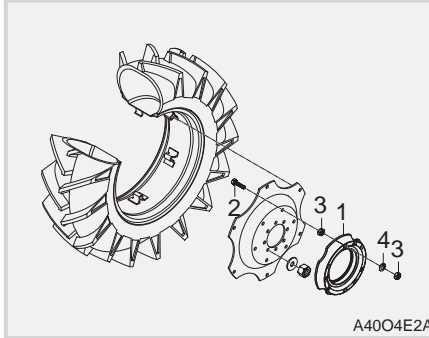

A4004E2A

(1) Rear Weight (2) Bolt  
(3) Nut (4) Spring Washer

For detailed information on installation, contact your local **KIOTI** Dealer.

#### Max. load

441 lbs (200 kg) (100 kgx2 Pieces)

### ⊕ IMPORTANT

- Attach only required amount of weight.

### ⊕ IMPORTANT

- Unnecessary weight can result in poor braking performance, rapid wear of the brake discs, shortened axle life, and increase in fuel consumption.

**ADDITIONAL LIQUID TYPE WEIGHT**

It is possible to inject water and calcium solution into the tire to use it as a ballast.

 **NOTE**

- The liquid injection should be performed only by a qualified service personnel.  
For detailed information, contact your local **KIOTI** Dealer.

If one liter of water is mixed with 0.4 kg of calcium, this liquid does not freeze down at -45 °C (-49 °F).

For a tire without a tube, fill it with water and calcium solution at least to the valve stem level (75%).

If the tire without a tube is not filled with water and calcium solution sufficiently, a part of the rim is exposed, resulting in corrosion.

For a tire with a tube, fill it up to 90% of its level.

 **NOTE**

- If the liquid injection should be performed only by a qualified service personnel.  
For detailed information, contact your local **KIOTI** Dealer.

## MASS(ES) AND TIRE(S)

Ref to the following information for the determination of the total mass, the axle loads, the tire load carrying capacity.

Tyre combination No	Axle No (※)	Tyre dimension including load capacity index and speed category symbol	Rolling radius [mm]	Rim Size	Off- set	Tyre Load rating per tyre [kg]	Maximum permissible mass per axle [kg](*)	Maximum permissible mass of the vehicle [kg] (*)	Maximum permissible vertical load on the coupling point [kg](**)	Tyre pressure [kPa] (***)	
										On-road use	Off-road use
1	1	12.4-24 8PR	564	W9	18.5	2,830	7,100	1,500	216	216	
1	2	18.4-30 8PR	721	W15L	30	4,270	7,100	1,500	157	157	
2	1	13.6-24 8PR	579	W11	18	2,830	7,100	1,500	216	216	
2	2	18.4-34 10PR	774	W15L	30	4,270	7,100	1,500	157	157	
3	1	320/85 R24 119A8	551	W9	18	2,830	7,100	1,500	157	157	
3	2	460/85 R30 142A8	729	W15L	30	4,270	7,100	1,500	157	157	
4	1	340/85 R24 121A8	567	W11	18	2,830	7,100	1,500	157	157	
4	2	460/85 R34 144A8	752	W15L	30	4,270	7,100	1,500	157	157	
5	1	360/70 R24 122A8	546	W11	18	2,830	7,100	1,500	157	157	
3	2	460/85 R30 142A8	729	W15L	30	4,270	7,100	1,500	157	157	
6	1	380/70 R24 125A8	567	W11	18	2,830	7,100	1,500	157	157	
5	2	480/70 R34 143A8	749	W15L	30	4,270	7,100	1,500	157	157	

※ Axle No. 1 & 2 are front & Rear axles.

(\*) According to the tyre specification.

(\*\*) Load transmitted to the reference centre of the coupling under static conditions, irrespective to the coupling device; if the maximum permissible vertical load on the coupling point depending on the coupling is indicated in this table, expand the table at the right side and indicate the identification of the coupling device in the header of the column; for R- or S-category vehicles this column(s) concerns the rear coupling devices if there is such a device.

(\*\*\*) As recommended by the manufacturer.





# OPERATION

**PRE-OPERATION CHECK..... 5-2**

**OPERATING THE ENGINE ..... 5-3**

    STARTING THE ENGINE .....5-3

    STOPPING THE ENGINE.....5-7

    WARMING UP .....5-8

    JUMP STARTING .....5-9

**OPERATING THE TRACTOR ..... 5-10**

    HOW TO DRIVE .....5-10

    PARKING .....5-14

    TURNING .....5-15

    DRIVING ON SLOPE .....5-15

    THE CAUTIONS WHEN COMING IN AND OUT OF WORK FIELD .....5-16

    PRECAUTIONS WHILE DRIVING ON THE ROAD .....5-16

    LOADING INTO AND UNLOADING OUT OF THE TRUCK .....5-17

    PRECAUTIONS WHEN USING POWER STEERING .....5-17

    3-POINT HITCH CONTROL SYSTEM .....5-19

    REMOTE HYDRAULIC .....5-20

    CONNECTING AND DISCONNECTING IMPLEMENT .....5-22

# 5



## PRE-OPERATION CHECK

It is a good practice to know the condition of your tractor before you start it. You should do routine check before each use.

### CAUTION

- **Park the tractor on the level ground, stop the engine, and apply the parking brake before checking or repairing it.**  
Refer to “DAILY CHECKING ITEM” in the section 7 “MAINTENANCE” for pre-operation check.
- **Be sure to read and understand the information titled as “DANGER”, “WARNING”, and “CAUTION” thoroughly for the safe operation.**

### CHECK ITEM

- Walk around inspection.
- Engine oil level.
- Urea level inspection
- Transmission oil level.
- Coolant level.
- Clean the front grill and radiator screen.
- Air cleaner element.
- Brake pedal free play.
- All dash gauges and indicators.
- Head lights, tail lights, and working lights.
- Accessible wiring harness for any damage.
- Seat belt and **ROPS** for damage.
- All "DANGER" and "WARNING" decals.
- Fuel level.
- Tire pressure and wheel bolt tightening condition.
- 3-point hitch and secure pins.

For detailed information, refer to "Maintenance schedule chart" in chapter 7.

### INITIAL OPERATION

Driving a new tractor at a high speed or under heavy load can affect its durability.

Make sure to run the tractor at the proper work load and speed for the initial operation of 10 to 20 hours.

### TIPS FOR BREAKING-IN

1. Start the engine and idle the engine at a low speed for 3 to 4 minutes in advance.
2. Increase the idling time in cold weather.
3. Do not drive the tractor at the maximum speed on a road.
4. Never apply excessive load during work.
5. Idle the engine at a low speed for 2 to 3 minutes before stopping it.



## OPERATING THE ENGINE STARTING THE ENGINE

### ⚠ WARNING

*To avoid accidents :*

- *Be sure to read and understand the warning and caution decals on the tractor thoroughly.*
- *Run the engine only in a well-ventilated area, or you can be suffocated by exhaust gas.*
- *Never start the engine unless you are on the driver's seat. The tractor can abruptly start off, resulting in an injury or accident.*

### ⊕ IMPORTANT

- Use of a starting aid can cause serious damage and will not be covered under warranty
- Never try to start the engine for over 10 seconds consecutively to protect the start motor and battery from damage.

### ENGINE STOP FUNCTION WHEN LEAVING THE DRIVER'S SEAT (EU ONLY)

#### • Condition:

If the driver leaves the seat for more than 2 seconds, the engine is turned off.

#### • Operation continuance condition when operator leaves from the seat:

When parking brake in ON and Shuttle lever is in a neutral position.

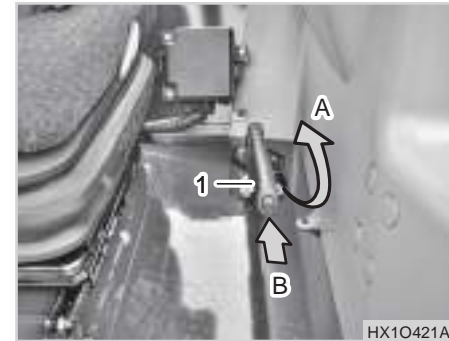

(1) Parking Brake Lever

(A) Pull

(B) Push

5

1. Make sure there is no obstacle around the tractor.

2. Make sure the parking brake is set

### 📖 NOTE

- When the parking brake is engaged, the parking brake lamp on the instrument cluster illuminates. When releasing it, the parking brake lamp is turned off.



HX1O406A

- (1) PTO Auto/Manual Switch
- (2) PTO Main Switch
- (A) AUTO      (B) MANUAL

3. Press the PTO switch to the "OFF" position.
4. Set the main, range and shuttle shift levers in the neutral position.



HX1O417A

- (1) PTO Change Lever

5. Place the PTO change lever in the neutral position (N).

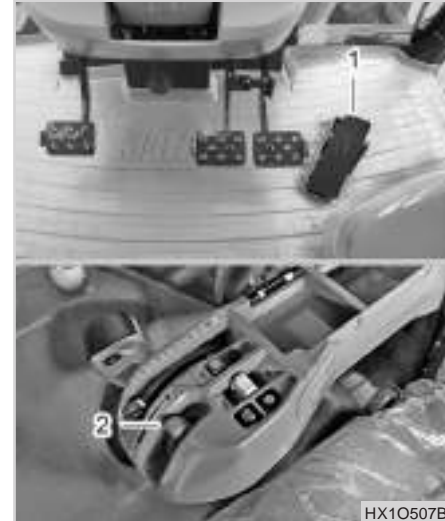

HX1O507B

- (1) Hand Throttle Pedal
- (2) Hand Throttle Lever
- Slow      Fast

6. Place the speed control lever in the mid speed position.
7. Depress the clutch pedal. (The engine cannot be started if the shuttle lever is not in the neutral position or the PTO main switch is not in the OFF position.)

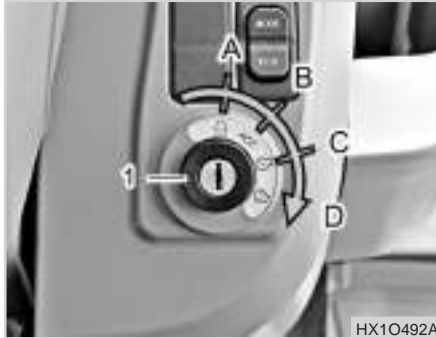

(1) Key Switch  
(A) OFF (B) ACC  
(C) ON (D) Start

8. Insert the key into the key switch and turn it "ON". Maintain it until the preheat lamp is turned off.

### NOTE

#### OPERATING PRINCIPLE OF PREHEAT SYSTEM

- When the ignition switch is set in the "ON" position, the engine coolant is automatically preheated. As soon as the preheat indicator goes off, start the engine.
- After starting the engine, in the "ON" position, the post-heating is variable depending on the coolant temperature.

### WARNING

- **Never operate the start motor for 10 consecutive seconds as it consumes a lot of battery power. If the engine cannot be started within 10 seconds, wait for 30 seconds and try again.**
- **Never try to crank while the flywheel is turning.**

9. When the engine is started, release the key. Then, the key is automatically turned back to the "ON" position.

### WARNING

- **Do not turn the key switch to the "Start" position while the engine is running.**

10. Warm up the engine for 3 to 4 minutes (10 minutes in winter) after releasing the clutch pedal.

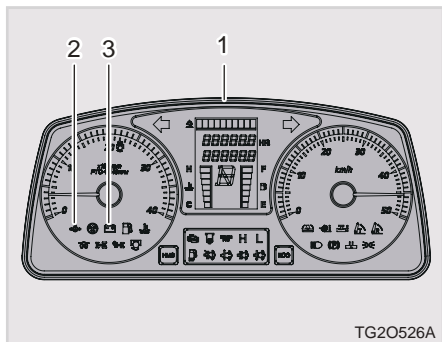

- (1) Instrument Panel  
 (2) Engine Oil Pressure Warning Lamp  
 (3) Charge Warning Lamp

11. Check to see that all the warning lamps on the instrument cluster turn "OFF". If any lamp remains on, immediately stop the engine and determine the cause.

### CHECKING WARNING LAMPS

1. If the oil pressure warning lamp(2) does not go off in 4 to 5 seconds after the engine is properly started, stop the engine immediately and check the engine oil level. If the engine oil level is proper, contact your local **KIOTI Dealer**.

#### **⚠ WARNING**

- ***The engine can be severely damaged if it is run with the oil pressure warning lamp ON.***

2. If the charge warning lamp(3) does not go off in 4 to 5 seconds after the engine is properly started, it means that the battery is not being charged. Have the charging system, such as the battery and alternator, serviced.

3. Refer to "Instrument panel" in chapter 4 for detailed information about other indicators and lamps.

#### **⚠ WARNING**

- ***If driving the tractor for an extended period of time with the charge warning lamp ON, the battery can be discharged and the tractor's electrical system can be damaged.***



## STOPPING THE ENGINE

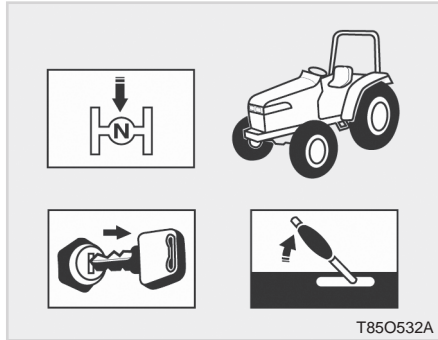

1. Make sure to reduce the engine rpm before stopping the engine.
2. Depress the clutch pedal and put all shift levers in the neutral position.
3. Run the engine at the idle speed for approx. 2 to 3 minutes, and then turn the key switch to the "OFF" position to stop the engine.

### ⚠ WARNING

- **Never touch the muffler or hot covers until they are cooled down after running the engine or driving the tractor.**

### ⊕ IMPORTANT

- **Turn off all the electrical devices and remove the ignition key before leaving the tractor.**
- **Do not leave the tractor outside unattended. It can be stolen as the key used for all KIOTI tractors are the same in shape.**
- **The horn, turn signal lamp and hazard lamp can be operated without the key inserted. Therefore, using these components without the engine started can discharge the battery.**

### 📖 NOTE

- When setting the ignition switch to the OFF position after operation, the pump is operated to return urea left in the urea pump and injector back to the tank, making a ticking sound. This is normal.
- Do not set the battery cut-off switch to the OFF position or disconnect the battery during this state.
- This takes for approximately two minutes.



## WARMING UP

It is recommended always to warm up the engine before driving in order to maintain the durability of the engine. Before warming up the engine, make sure that each part in the engine is properly lubricated and each hydraulic part is in a perfect condition in order to prevent malfunction in the engine as well as the hydraulic system.

### NOTE

- In case of abrupt acceleration with cold engine, the engine speed is automatically limited according to the oil pressure and temperature in order to protect the turbocharger from damage.
- Warm up the engine for 3 to 4 minutes at the low idle speed to utilize optimum performance of the engine.

## HOW TO WARM UP ENGINE

1. Start the engine and run it at a low speed and without load for approx. 3 to 4 minutes.
2. In cold weather, increase the warming up time to 10 minutes.
3. If it is very cold, warm up the engine for approx. 15 minutes.
4. The engine throttle can be open for 50 % in order to shorten the warming up time.
5. The engine is sufficiently warmed up when the temperature gauge on the instrument panel indicates 1/2 of the normal temperature range, regardless of the warming-up time.
6. Do not increase the work load rapidly after starting work.
7. Run the engine without load for approx. 2 to 3 minutes before stopping the engine after work.

### WARNING

- ***Warming up the engine excessively increases fuel consumption and affects the durability of the tractor negatively.***
- ***Never warm up the engine and leave the tractor for an extended period of time. It can cause fire and an accident.***
- ***Never leave the tractor unattended while warming up.***





## JUMP STARTING

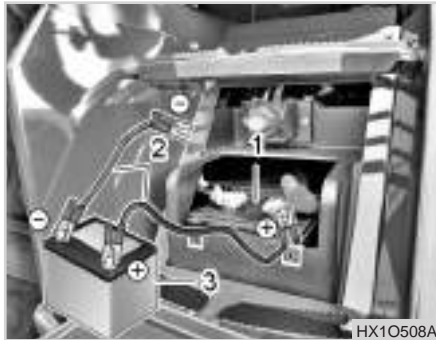

(1) Dead Battery      (2) Jumper Cables  
(3) Helper Battery

If the battery is discharged and the engine cannot be started, it is possible to start the engine by connecting the discharged battery to a battery from another tractor or other extra battery.

1. Check that the voltage of the discharged battery is same as the voltage of the other tractor or vehicle for jump start. (Specification for this tractor: 12V)
2. Check the length of the jump cable

and position another tractor near the tractor with the discharged battery. Then, put all the shift levers in the neutral position, apply the parking brake, and stop the engine.

3. Wear protective glasses and gloves and open the hoods of both tractors. Remove the battery terminal cover as necessary.
4. Connect the alligator clips on both ends of the red positive cable to the positive terminals of both batteries.
5. Connect one clip of the black negative cable to the negative terminal of the normal battery and the other clip to the tractor body with the discharged battery. Make sure to connect the clip to the body part without paint.
6. Start the engine of the tractor with the normal battery.
7. Start the engine of the tractor with the discharged battery.

8. Disconnect the black cable from the negative battery terminals of both of the tractors.
9. Disconnect the red cable.
10. Run the engine for at least 30 minutes to charge the discharged battery.
11. If the battery is discharged again, replace it or check the charging system, such as the alternator.

## OPERATING THE TRACTOR HOW TO DRIVE



(1) Seat Adjustment Lever

1. Adjust the seat and fasten the seat belt.

### ⚠ WARNING

- After adjusting the seat, check that the seat is securely fixed.
- Do not adjust the seat while driving. The seat may move suddenly and miss the tractor handle.

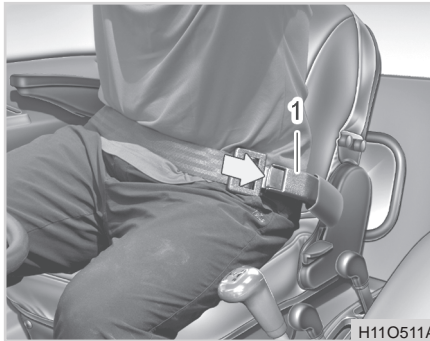

(1) Seat Belt

2. Wear the seat belt.

### ⚠ WARNING

- Always wear the seat belt when cap is installed.
- If the seat belt is worn across the abdomen or waist, not the hips, an injury can occur in case of an accident or impact.
- Do not wear the seat belt if the ROPS is not installed or folded.

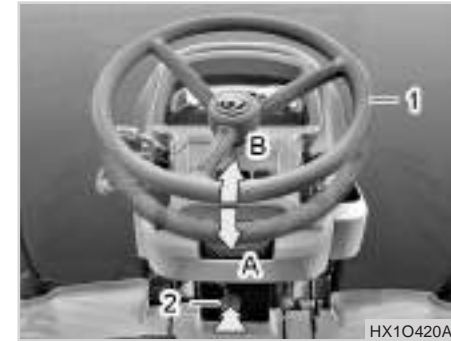

(1) Handle  
(A) Lowering  
(2) Tilt Pedal  
(B) Lifting

3. Adjust the steering wheel according to the driver's physique.

### ⚠ WARNING

- Do not adjust the tilt angle of steering wheel while driving. You could lose the handle of your tractor, causing an accident.

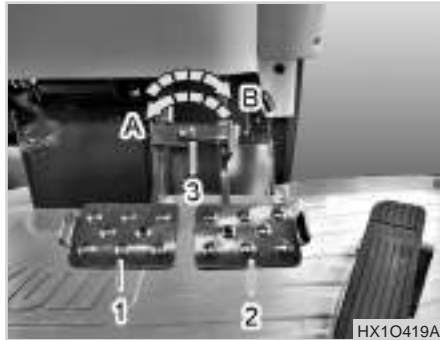

HX10419A

- (1) Brake Pedal (LH)  
 (2) Brake Pedal (RH)  
 (2) Pedal Interlock  
 (A) Unlock (B) Lock

4. Make sure that both of brake pedals are interlocked.

**⚠ WARNING**

- **If depressing only one brake pedal at a high speed, the tractor can lose its balance and be overturned.**



HX104E3A

- (1) Position Control Lever  
 (2) One-touch Lifting Lever

5. Pull the position control lever backward to raise the attachment on the 3-point hitch.



HX10423C

- (1) Accel Pedal  
 (2) Hand Throttle Lever  
 🐢 Slow 🐕 Fast

6. Increase slowly the engine RPM from idle speed to the medium speed.

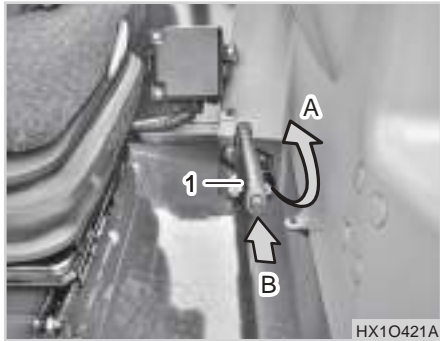

(1) Parking Brake Lever  
(A) Pull (B) Push

7. To release the parking brake lever, pull up and press the thumb button. Then, while holding the button in, lower the brake lever.

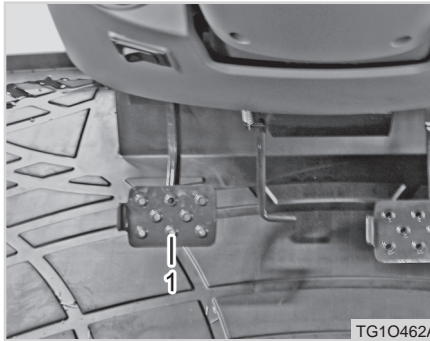

(1) Clutch Pedal

8. Depress the clutch pedal fully.

**⚠ CAUTION**

**To avoid accidents :**

- Do not release the clutch pedal abruptly. The tractor may start off abruptly, resulting in rollover.



(1) Shuttle Shift Lever  
(F) Forward (N) Neutral (R) Reverse

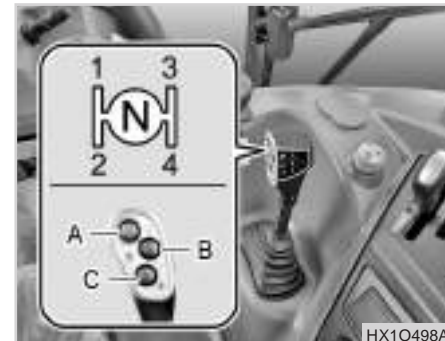

(1) Main Shift Lever (A) Hand Clutch  
(B) High Speed Selection Switch  
(C) Low Speed Selection Switch



(1) Range Gear Shift lever  
 (C) Creep Speed (H) High Speed  
 (L) Low Speed (M) Mid Speed  
 (N) Neutral

9. Change the main shift lever, range shift lever and shuttle lever to the position you want.



(1) Range Gear Shift lever  
 (H) High Speed  
 (M) Mid Speed (L) Low Speed

10. The tractor begins to move as you release the clutch.

### ⚠ CAUTION

- Never put your foot on the clutch pedal during driving. The clutch disc can be rapidly worn.
- Make sure to operate the clutch fast when disengaging it and slowly when engaging it.
- Do not change the tractor speed abruptly for safe driving.
- When driving on a slope or loading or unloading the tractor to a transporting vehicle, reduce the speed in advance so that there is no need to shift the gear in the middle of the slope. Also, do not put your hand on the shift lever while driving on a slope. The tractor may roll down the slope due to the disengaged gear which is very dangerous.

## PARKING



(1) Chocks

(2) Parking Brake Lever

1. This tractor is equipped with a separate parking brake.

2. Pull the parking brake lever (2) up.
3. Before leaving the tractor after parking it, make sure to stop the PTO, lower the implement onto the ground, and stop the engine.
4. If it is necessary to leave the tractor with the engine running, put all the shift levers in the neutral position and apply the parking brake firmly.
5. When parking the tractor on a slope, stop the engine with the parking brake applied and every gears engaged in the low speed gear.
6. If it is necessary to park the tractor on a slope with the engine running, apply the parking brake and chock all four wheels.
7. In order to release the parking brake, push the button of parking brake and lower the parking brake.

### **⚠ WARNING**

- *The brake pad can be rapidly worn if you drive with the parking brake applied.*
- *Never park the tractor on a steep slope in any circumstance. A severe accident can happen.*

### **⚠ WARNING**

*To avoid possible injury, death or loss of property from a machine runaway :*

- *With the engine off, the tractor may move unexpectedly regardless of the gear shift position.*
- *Before leaving the tractor, certainly apply the parking brake to prevent machine runaway.*

※ *Only power shuttle model.*



### ⊕ IMPORTANT

- The tractor may move slowly with the engine running even though the main and shuttle shift levers are in the neutral position. This is normal and is due to the fluid friction in the transmission. This symptom can occur easily when the engine rpm is high, the low speed gear is selected by the range shift lever, and the viscosity of the transmission fluid is high due to low temperature. To prevent this symptom, make sure to apply the parking brake.
- Get off the tractor after checking that the tractor is completely stopped and the parking brake is firmly applied.
- Do not park the tractor on tall grass or hay. If grass or hay contacts with the muffler, it can catch fire.

## TURNING

You should turn slowly and lower the engine speed if possible.

### ⚠ WARNING

*To prevent accidents due to loss of steering control :*

- *If you turn at high speed, the tractor can turn over.*
- *Never use the differential lock system turning at high and low speeds. A serious accident can occur.*

## DRIVING ON SLOPE

1. Please drive according to the conditions of the slope at safe speed so that the engine is not under heavy load if possible.
2. Make sure to shift to the lower gear in order to prevent the engine from stalling on an uphill.
3. On the downhill slope, drive at the low speed.

### ⚠ WARNING

- *Make sure that the coupling device of brake pedal interlock and differential lock pedal are released.*
- *Do not disengage the clutch or put the shift lever in the neutral position on a slope. Otherwise, a runaway condition could occur.*
- *Before entering a steep slope, move the shift lever down to a proper gear and never try to move the shift lever on a slope. "A" serious accident can occur.*

### THE CAUTIONS WHEN COMING IN AND OUT OF WORK FIELD

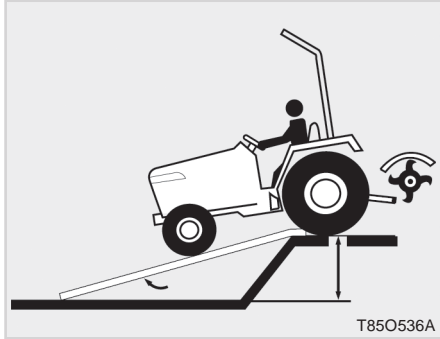

1. Make sure that the left and right pedal are interlocked.
2. Enter and exit the field by driving the tractor at a right angle to the bank.
3. It is recommended to use the 4WD and drive backward when moving onto a bank.

### PRECAUTIONS WHILE DRIVING ON THE ROAD



(1) Turn Signal Light

1. When you change the driving direction on the road, let the other car know your direction with turn signal lights.
2. Do not use high beam headlights when another vehicle is approaching from the opposite direction so that not to interrupt another driver's view.
3. Always interlock the left and right brake pedal while driving on the public road.

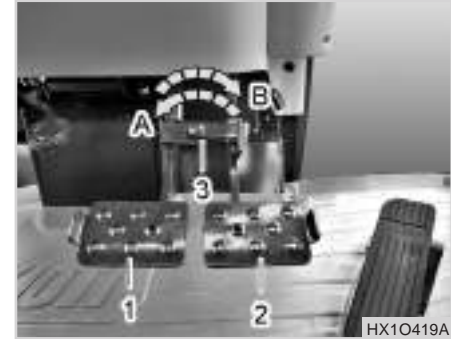

(1) Brake Pedal (LH)    (2) Brake Pedal (RH)  
 (3) Pedal Interlock  
 (A) Unlock  
 (B) Lock (Whenever traveling on the road)

#### **⚠ WARNING**

- **When you are driving on the road, observe all local traffic and safety regulations. If not, you can have an accident of bodily injury on a person.**
- **Only the operator should ride on the tractor unless a passenger seat is installed.**



**⚠ WARNING**

- *If the tractor is broken down during driving on the road, move it to a safe place to service. If not, it can cause personal injury.*

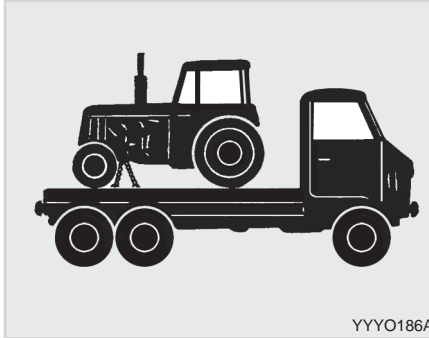
**LOADING INTO AND UNLOADING OUT OF THE TRUCK**

1. When you load the tractor, do it by driving backward.
2. If the engine stalls out halfway, step on the brake pedal at once, and then take away the pedal slowly to reach the road. After that, restart the engine again to go up.

**⚠ WARNING**

- *Attach the tractor securely to the truck when transporting. Be aware of the height of the loaded tractor and avoid low clearance areas.*
- *Follow this instruction to avoid accidents*

**PRECAUTIONS WHEN USING POWER STEERING**

(1) Power Steering Handle

1. The power steering function is activated only while the engine is running. However, the steering wheel becomes slightly firmer when the engine is running at a low speed. The steering wheel can be operated but becomes very firm while the engine is stopped.

2. If you operate the steering wheel, with the tractor stopped, using the implement equipped in front of the loader and the like, the steering wheel operation can be getting a little firm. Operate the steering wheel moving the tractor in this case.
3. When a loader is mounted, adjust the air pressure of the front wheel to its maximum specification and mount weight or implement on the 3 point hitch of the tractor, and remove the front weight to make the front and rear balance more stable for safe working.
4. When turning the steering wheel to its end, the operating sound of the safety valve (Relief valve) can be heard. Do not use the tractor against the relief valve for extended periods. Hydraulic temperature may increase and damage the tractor.

### NOTE

The power steering system in this tractor is a load reaction, full hydraulic type.

- The full hydraulic system means that power necessary for power steering is transferred by hydraulic fluid only and therefore mechanical devices, such as racks and pinions, are not installed to the tractor. Therefore, the angle of the **KIOTI** emblem on the center of the steering wheel may differ occasionally, which is normal.
- The load reaction type means that the reaction force or impact applied to the front axle is transferred to the steering wheel. Therefore, the steering wheel can be returned to its straight-forward position from the turning position.

### WARNING

- ***When driving on a road with an implement attached to the rear of the tractor, the friction of the front wheels becomes poor, resulting in poor steer ability. In this case, attach a proper front weight and drive at a low speed.***
- ***If malfunction occurs while driving on a road, stop the tractor in a safe place and service it. If it is not possible to move the tractor, turn on the hazard lights and set a warning triangle behind the tractor. Otherwise, a rear end accident may occur.***
- ***The center of gravity of the tractor is higher compared to other common vehicles, so the possibility of the roll-over accident is very high. Be extra careful when driving on a lateral slope, bumpy road, road with puddles, and narrow road. Make sure to set the ROPS in its original position (up straight position) and fasten the seat belt.***

**⚠ WARNING**

- *If stopping the engine while driving, the steering performance can become deteriorated due to loss of hydraulic power, resulting in a severe accident. Never stop the engine while driving.*
- *Always grip the steering wheel using both hands while driving.*

**3-POINT HITCH CONTROL SYSTEM  
POSITION CONTROL LEVER**

- (1) Position Control Lever  
(2) One-touch Lifting Lever

**▶ POSITION CONTROL**

1. The position control lever is used to lift or lower the lifting arm (lower link) of the 3-point hitch.
2. Pushing the lever forward lowers the lower link while pulling the lever backward lifts the lower link.

3. The height of the lower link is precisely controlled proportional to the position of the lever.
4. The lower link is lifted by the hydraulic energy of the tractor while it is lowered by potential energy of its own weight. Therefore, the implement cannot be lowered by the hydraulic pressure.
5. Therefore, the implement attached to the lower link may be lifted by protrusion on the ground when it is lowered to the ground. It is called as "floating".

**NOTE**

- If the position of the position control lever is changed before/after the engine is started, operating the lever won't move the 3-point link (3-point safety lock control function).
- In this case, press the lifting or lowering position of the one touch button to release the safety lock control function of the 3-point link.

## REMOTE HYDRAULIC DOUBLE ACTING VALVE



- (1) Double Acting Lever (Self-return type)  
 (2) Double Acting Lever (Detent type)  
 (3) Lock Lever
- |            |            |
|------------|------------|
| (A) Port A | (B) Port B |
| (C) Port C | (D) Port D |
| (E) Port E | (F) Port F |

KIOTI supplies two types of the double acting valves by region : self-return type and detent type.

- For the self-return type double acting lever, it returns to its neutral position to block the hydraulic fluid when it is pushed/pulled and then released.

Therefore, this type of double acting valve lever should be pulled or pushed continuously for operation which is suitable for an implement with a short operating time, such as the hydraulic cylinder.

- For the detent type double acting valve lever, it keeps its position after it is pulled or pushed to a certain position. Therefore, it is not necessary to hold the lever to a certain position which is suitable for an implement with a long operating time, such as the hydraulic motor.

### ⊕ IMPORTANT

- **Put the detent valve operating lever into the neutral position when the hydraulic implement is not in use. If the detent valve is kept in the operating position for an extended period of time, the relief valve is kept open and the temperature of the hydraulic fluid rises, leading to damage of various hydraulic parts, such as the oil seals and O-rings.**
- **When the detent valve is in operation, unnecessary load is applied to the engine. Therefore, the engine power decreases significantly, and noise and vibration by opening of the relief valve increase.**
- **It is hard to start the engine while the detent valve is in operation. This is especially true in winter and exhaust gas increases even after the engine is started.**



## SINGLE ACTING AND DOUBLE ACTING CYLINDER

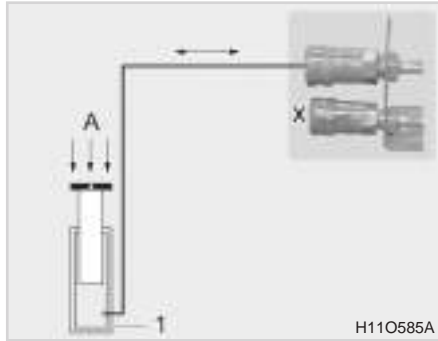

(1) Single Acting Cylinder  
(A) External Load

This tractor is equipped with the remote control valve of the double acting type. However, this valve can also be used in the single acting type hydraulic cylinder.

1. Connect one end of the hydraulic port to the single acting cylinder as shown in the figure. The hydraulic pressure is properly supplied to the cylinder. However, when the hydraulic pressure is released, the cylinder is contracted only if there is outer force, such as potential energy.

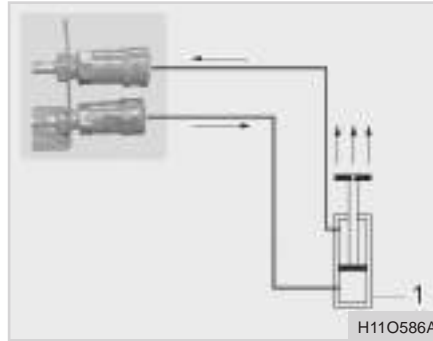

(1) Double Acting Cylinder

2. To contract the cylinder, operate the lever to the opposite direction of the expansion. Then, the hydraulic fluid is supplied from the hydraulic pump to the hydraulic port which is not connected, and the pressure rises as the port is blocked. However, this pressure is released as the relief valve opens.

3. When the cylinder is contracted, the hydraulic fluid returned from the cylinder is drained to the transmission through the draining circuit as the operating lever is operated to the opposite direction from the expansion position.

### ⊕ IMPORTANT

- It is recommended to use the double acting cylinder instead of the single acting cylinder if the implement will be operated frequently and continuously. If using the single acting cylinder too frequently or for an extended period of time, the hydraulic fluid can be overheated, resulting in deterioration of the hydraulic parts' durability as the main relief valve opens at cylinder contraction.

## PT1/2 COUPLER SOCKET (IMPLEMENT)

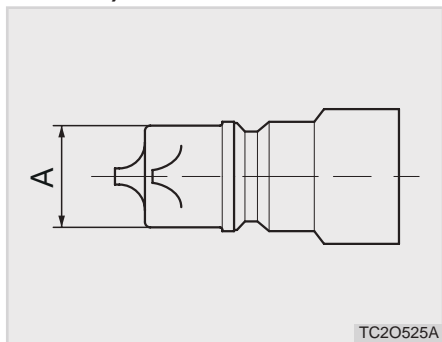

(A) Diameter

The hose unions used must comply with ISO standards.

Dimension (A) must be between 20.48 and 20.56 mm (0.806 and 0.809 in.).

## CONNECTING AND DISCONNECTING IMPLEMENT CONNECTION

1. Make sure to stop the engine before connecting it.
2. Move the double acting valve lever forward and backward for 4 to 5 times to release the pressure in the hydraulic line of the tractor. Otherwise, it is hard to connect the couplers, and hydraulic fluid can be sprayed from the line and get in to your eyes while connecting them.
3. Remove any foreign material around the male and female couplers. If foreign material enters the hydraulic components, it can lead to malfunction of the system.
4. Open the dust-proof cover of the female coupler of the tractor and insert the male coupler of the implement. A clicking sound is heard when the couplers are engaged.
5. Pull the hydraulic hose of the implement to check that the couplers are properly connected.
6. Start the engine and check the operating status and leakage.

## DISCONNECTION

1. Make sure to stop the engine before disconnecting it.
2. Release any residual pressure in the hydraulic hoses of the implement and tractor by operating the double acting valve lever 4 to 5 times.
3. Remove any foreign material around the couplers.
4. Keep the implement balanced by removing any load applied. (Lowering it onto the ground, for example)  
If disconnecting the hose while outer load is applied to the implement, it is hard to connect the implement in the future.
5. Remove the male coupler by pushing the female coupler boss of the tractor backward.
6. Close the dust-proof cover of the female coupler of the tractor. Wrap the male coupler of the implement with a plastic bag to prevent contamination.

**⚠ WARNING**

- *Never connect or disconnect the implement hydraulic hose while the pressure in it is not released or the engine is running. It is hard to connect and disconnect the hose and hydraulic fluid can be sprayed from the hose, and get into your eyes or skin.*
- *Stop the engine and wear protective glasses and gloves before work.*



MEMO







## 3-POINT HITCH IMPLEMENT AND LOADER OPERATION

### REMOVAL AND INSTALLATION OF 3-POINT HITCH IMPLEMENT (WITH PTO SHAFT) ..... 6-2

### OPERATION FOR 3-POINT HITCH IMPLEMENTS.... 6-8

ADJUSTMENT OF TOP LINK .....6-8

PRECAUTION FOR INSTALLING HOW TO USE TOP LINK HOLES.....6-9

ADJUSTMENT OF STABILIZER .....6-10

DRAFT HITCH AND TRAILER .....6-10

PTO & PTO SHIELD GUARD.....6-12

INSTALLING PTO SHAFT.....6-12

HYDRAULIC BRAKE VALVE (IF EQUIPPED).....6-13

### HANDLING LOADER..... 6-15

DRIVING ON SLOPE.....6-16

JOYSTICK LEVER.....6-17

# 6

6



## REMOVAL AND INSTALLATION OF 3-POINT HITCH IMPLEMENT (WITH PTO SHAFT)

### [EU: QUICK TYPE]



(1) Implement Support (2) Lower Link



(1) Check Link Pin



(1) Lever (2) Ball Assembly

1. Place implement on the level ground.
2. Drive the tractor backward to move as close as possible to an implement. (approx. 5 cm)  
Then, adjust the height of the lower link to be parallel to the pins of the implement.
3. Put all the shift levers in the neutral position.

4. Remove the pins on either side of the check link.

5. Remove the ball assembly by pushing the guide pin operating lever.



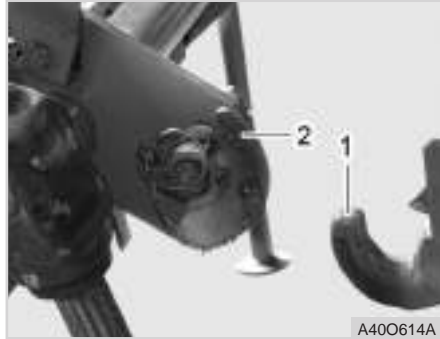

(1) Lower Link

(2) Ball Assembly



(1) Lower Link

(2) Ball Assembly

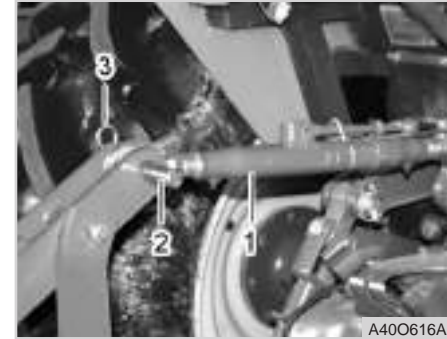

(1) Top Link  
(3) Snap Pin

(2) Lock pin

6. Attach the ball assembly to the implement.

7. When the lower link is lifted, it is secured with "click" sound.

8. Separate the top link from its bracket and turn it to adjust its length so that it becomes close to the upper bracket mounting hole of the implement. Then, fit it to the mounting hole, insert the lock pins, and fix it with the snap pin. Remove the implement support as necessary.

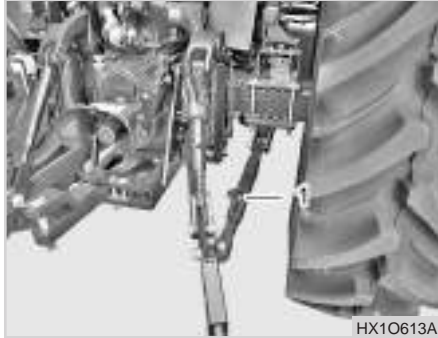

(1) Telescopic Stabilizers Pin

9. Turn the top link to make the implement balanced. Then, move the implement to the left and right, and secure it into the proper position by fitting the telescopic stabilizers lock pin
10. At this time, stop the engine, lower the implement onto the ground, and set the PTO gear neutral. The PTO shaft to the tractor PTO insuring the lock pin is engaged.

### ⊕ IMPORTANT

- Consult your local KIOTI Dealer for selection of the universal joint.
- When selecting a universal joint, make sure that it is not too short to come off its female and male shafts at the highest position or too long to impact its female and male shafts at the lowest position.
- Move the joint front and back to check that its lock pin is properly seated to the groove of the PTO shaft.

11. Remove the implement in the reverse order of installation and use the implement support as necessary.

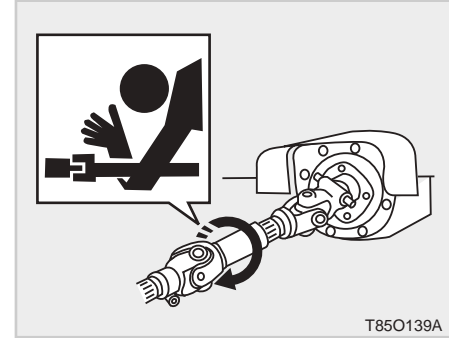

### ⚠ WARNING

- **Make sure that the PTO safe cover is in its position before driving the PTO shaft.**
- **The PTO shaft and universal joint shaft should not be interfered by any surrounding parts.**
- **Never go close to the rotating PTO shaft or universal joint shaft. "A" severe accident can happen.**

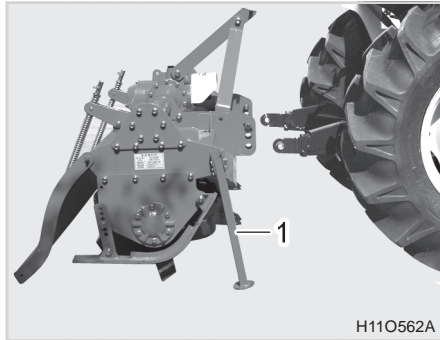
**[US: TELESCOPIC TYPE]**

(1) Implement Support

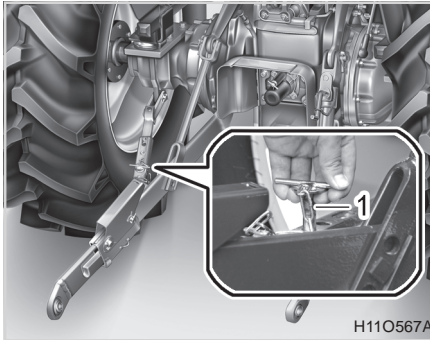

(1) Telescopic Stabilizers Pin



(1) Latch

(2) Lower Link End

1. Drive the tractor backwards to move close to an implement (approx. 5 cm). Then, adjust the height of the lower link to be parallel to the pins of the implement.
2. Put all the shift levers in the neutral position, stop the engine, and apply the parking brake.

3. Remove both of the Telescopic Stabilizers fixing pins.

**⊕ IMPORTANT**

- **When removing/installing an implement, remove the check link pin to use the lower link end (cassette type) effectively.**

4. Press the latch to pull out the lower link end. (Cassette type)

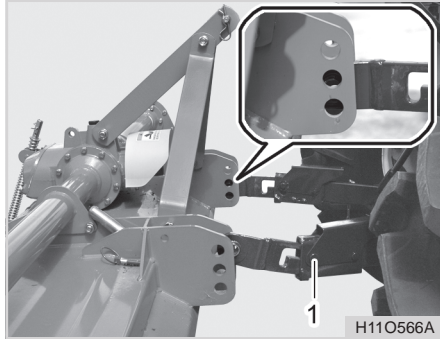

(1) Lower Link

5. Install the lower link to the implement and fit the pins.

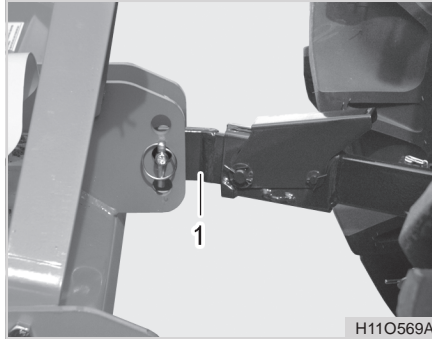

(1) Lower Link End

6. Start the engine and drive backward toward the implement. Then, the lower link end is inserted to its original position.

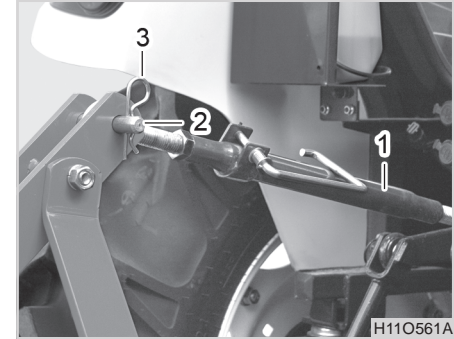

(1) Top Link  
(2) Lock pin

(3) Snap Pin

7. Separate the top link from its bracket and turn it to adjust its length so that it becomes close to the upper bracket mounting hole of the implement. Then, fit it to the mounting hole, insert the lock pins, and secure it with the snap pin. Remove the implement support as necessary.



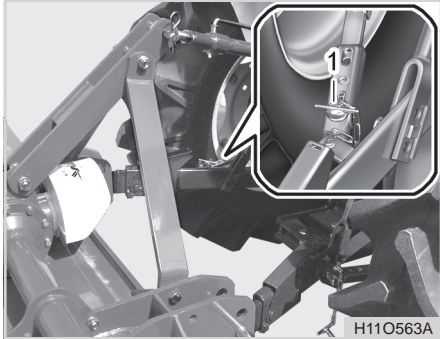

(1) Telescopic Stabilizers Pin

8. Turn the top link to balance the implement. Then, move the implement to the left and right, and secure it into the proper position by fitting the telescopic stabilizers lock pin
9. Connect the PTO shaft to the tractor's PTO if necessary. At this time, stop the engine, lower the implement onto the ground, and set the PTO gear neutral.

### ⊕ IMPORTANT

- Consult your local KIOTI Dealer for selection of the PTO shaft.
- When selecting a PTO shaft, make sure there is a minimum of 152 mm (6 inches) of overlap of the PTO shaft tubes when the shaft is extended to its maximum working length between the tractor and the piece of equipment. Also make sure there is 76 mm (3 inches) of clearance between the shaft tube ends and the universal joints at both ends when the PTO shaft is at its shortest working length between the tractor piece of equipment. If not, **DO NOT USE** the PTO shaft and contact a KIOTI dealer.
- Move the joint back and forth to check that its lock pin is properly seated to the groove of the PTO shaft.

10. Remove the implement in the reverse order of installation and use the implement support as necessary.



## OPERATION FOR 3-POINT HITCH IMPLEMENTS



HX10612A

- |                  |                  |                |                   |
|------------------|------------------|----------------|-------------------|
| (1) Top Link     | (3) Lift Rod (R) | (5) Lower Link | (7) Lift Cylinder |
| (2) Lift Rod (L) | (4) Check Link   | (6) Draw Bar   | (8) PTO Shaft     |

## ADJUSTMENT OF TOP LINK



HX10610A

- |               |         |
|---------------|---------|
| (1) Top Link  | (2) Pin |
| (3) Lynch Pin |         |

1. Install the top link to the desired position, and install the pin and lynch pin.
2. Undo and lower the top link hook, and unscrew the nut of the top link hole end. To increase the length, turn the top link hook clockwise. To decrease the length, turn it counter-clockwise. Finally, secure the link with the nut.





## PRECAUTION FOR INSTALLING HOW TO USE TOP LINK HOLES

**⚠ WARNING**

- Stop the engine and lower the attached implement onto the ground before detaching the implement from the lower link. Ensure that the attached implement is firmly supported and there is no pressure remained in the hydraulic system to remove the lower link holding the pin. To remove any residual pressure, push and pull the hydraulic control lever front and back several times.

**📖 NOTE**

- When there is no implement attached, fix the lower link to the check link (LH/RH) so that it does not contact with the rear wheel.
- Secure the top link to the hook.

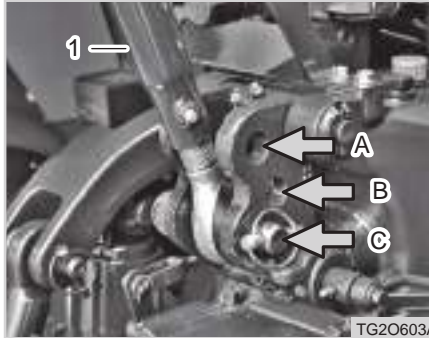

(1) Top Link

When attaching an implement, connect it according to its draft as follow.

- A: Traction power is not required (rotary etc.)
  - B: Heavy load traction work
  - C: Normal load traction work
1. Adjust an angle of the implements to the desired position by shortening or lengthening the top link.
  2. Adjusting top length varies as a type of implements used.

**⚠ CAUTION**

- When you are attaching an implement not requiring any traction, mount the assembling spot of the top link into the hole "A".
- When you are attaching an implement. (Like plow) Requiring some traction, mount the top link into the hole "B", "C".

## ADJUSTMENT OF STABILIZER

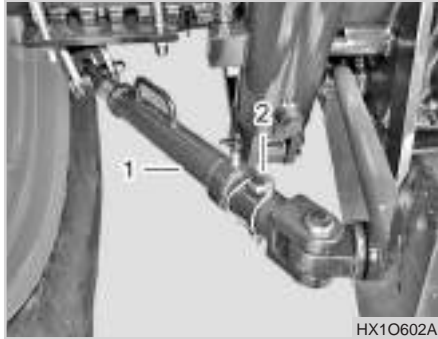

(1) Telescopic Stabilizers (2) Pin

1. Adjust the check link to control horizontal sway of the implement. It is also used to set the implement on the back of the tractor in center.
2. To adjust the check link, pull out the pin and adjust it until the desired transverse moving distance is obtained.
3. Fit the pin to the gardening hole (Fixed) for normal operation and long hole (Moving) for draft work.

## DRAFT HITCH AND TRAILER

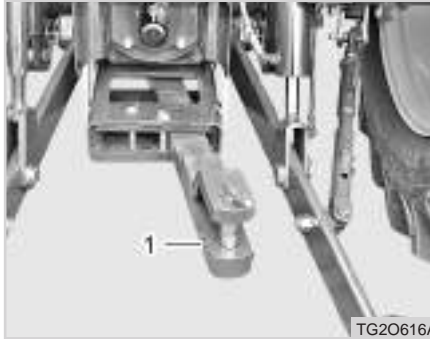

(1) Draw Bar

The draw bar is used to pull an implement, such as a trailer. This tractor is equipped with a draw bar. Make sure to check the max. towing weight of the trailer and max. vertical load that can be applied to the draw bar.

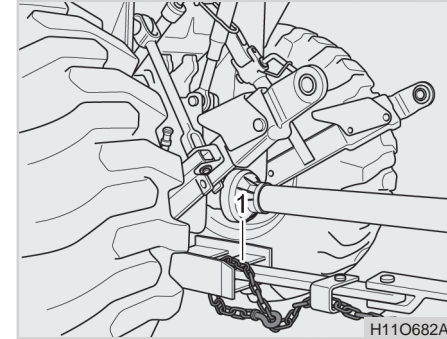

(1) Safety Chain

### **⚠ WARNING**

- **Never use any other part for pulling except draw bar. Pulling with top link, ROPS and etc. will cause a fatal accident.**
- **Be sure to install the auxiliary safety chain when installing a trailer.**

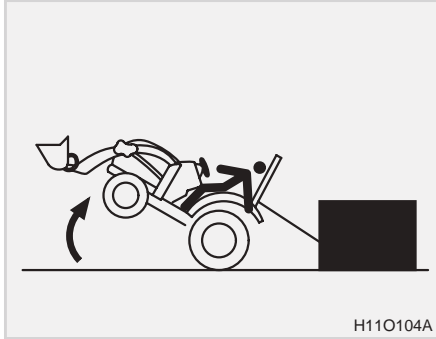

H11O104A

**⚠ WARNING**

- **Never use any other part for pulling except draw bar. Pulling with top link, ROPS and etc. will cause a fatal accident.**
- **Be sure to install the auxiliary safety chain when installing a trailer.**

Type (according to Appendix 1 to Annex XXXIV to Commission Delegated Regulation (EU) 2015/208)			Tractor drawbar
Make			DAEDONG, KIOTI
Manufacturer's type designation			T4837
Maximum horizontal load/D-Value (kN)			N/A
Towable mass (T)			8 tonnes
Maximum permissible vertical load on the coupling point (S)			1,500 kg
Position of coupling point	Height above ground	minimum	562 mm
		maximum	670 mm
	Distance from vertical plane passing through the axis of the rear axle(mm)	minimum	760 mm
		maximum	760 mm

**- For AA??, BB??, CC??**

R- and S category vehicle Brake	Drawbar		Rigid drawbar		Centre-axle	
	Unladen(**)	Laden(***)	Unladen(**)	Laden(***)	Unladen(**)	Laden(***)
Unbraked(*)	2,350 kg	3,500 kg	2,350 kg	3,500 kg	2,350 kg	3,500 kg
Inertia-braked	8,000 kg		8,000 kg		8,000 kg	
Hydraulic braked	N/A		N/A		N/A	
Pneumatic braked	N/A		N/A		N/A	

(\*)Unbraked trailer mass is depends on the weight conditions of the vehicle.  
 (\*\*)When the vehicle conditions is unladen, the trailer mass is 2350 kg.  
 (\*\*\*)When the vehicle conditions is laden, the trailer mass is 3500 kg.

### PTO & PTO SHIELD GUARD

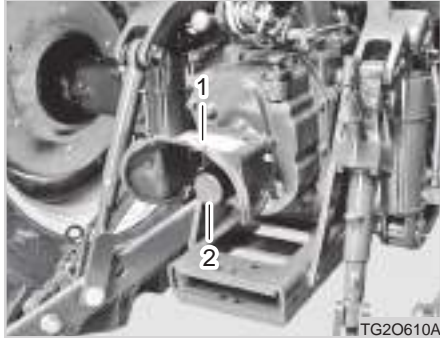

(1) PTO Shaft Cover  
(2) PTO Shaft Cap

Before you install the some kind of implement, take off PTO shaft cap(2) and install the universal joint of implement. If necessary, fold up the PTO shield guard (1).

### SPECIFICATION

PTO type	Nominal diameter	Number and type of splines	Nominal PTO rated rotational frequency	Recommended PTO power at rated engine speed(kW)
1	35	6 straight splines	540	Up to 60
			1,000	Up to 92

PTO shield guard	Category	Regulation
	T1	Compliance with ISO500-1

### INSTALLING PTO SHAFT

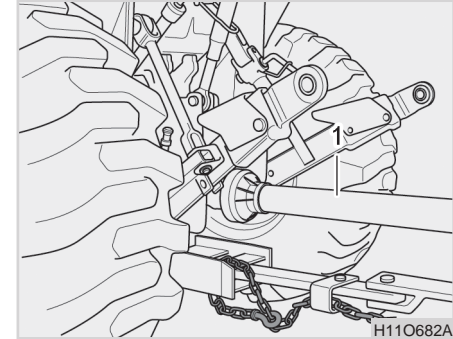

(1) Universal Joint

1. Consult your local **KIOTI** Dealer for selection of the universal joint.
2. When selecting a universal joint, make sure that it is not too short to come off the its female and male shafts at the highest position or too long to impact its female and mail shafts at the lowest position.
3. Move the joint back and forth to check that its lock pin is properly seated to the groove of the PTO shaft.

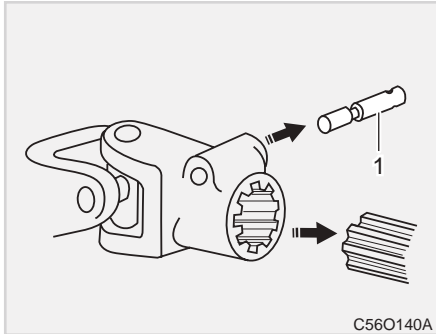

(1) Lock Pin

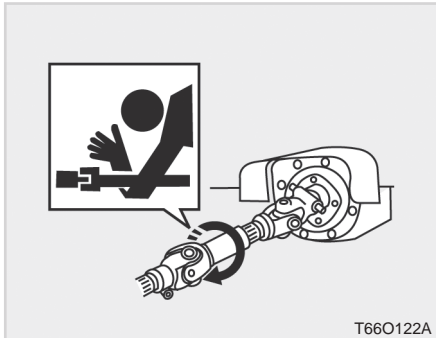
**⚠ WARNING**

- *Make sure that the PTO safe cover is in its position before driving the PTO shaft.*
- *The PTO shaft and universal joint shaft should not be interfered by any surrounding parts.*
- *Never go close to the rotating PTO shaft or universal joint shaft. A severe accident can happen.*

**HYDRAULIC BRAKE VALVE  
(IF EQUIPPED)**

(1) Coupler plug

(2) Trailer brake valve

1. Remove the coupler plug (1) of the rear brake valve.

2. Connect the hydraulic hose for trailer brake operation to the coupler (2) of the rear brake valve.
3. Depress the brake pedal of the tractor to confirm that the hydraulic brake of the towing trailer operates properly.

Before you use this brake valve, please check if the brake brand and types of the trailer are suitable with as below.

Trailer Brake Valve	
<b>Brand</b>	BOSCH
<b>Model</b>	Trailer-brake valv BV1R Oil 12
<b>Fluid type</b>	Mineral hydraulic oil (identical to the oil of the tractor)
<b>Dimensions</b>	Piston Ø12 mm
<b>Nominale pressure</b>	250 bar
<b>Maximal trailer-brake pressure</b>	140 +/-10 bar
<b>Installation area</b>	Rear of tractor

Trailer Brake Coupling	
<b>Brand</b>	SAFIM
<b>Model</b>	Included in trailer brake valve
<b>Norm</b>	ISO 5676-1983
<b>Fluid type</b>	Mineral hydraulic oil (identical to the oil of the tractor)
<b>Nominale pressure</b>	220 bar
<b>Installation area</b>	Included in trailer brake valve

⚠ CAUTION	
<ul style="list-style-type: none"> <li>• <b>When removing the plug from the coupler to connect the brake hose, make sure that no foreign material enters the coupler.</b></li> </ul>	

⚠ WARNING	
<ul style="list-style-type: none"> <li>• <b><i>Never exceed a speed of 25km/h (15 mph) when travelling with hydraulically braked trailers.</i></b></li> <li>• <b><i>If the number of brake operation increases during long distance driving, the oil temperature rises and the area around the coupler can be hot. Be careful not to get burned.</i></b></li> </ul>	



## HANDLING LOADER

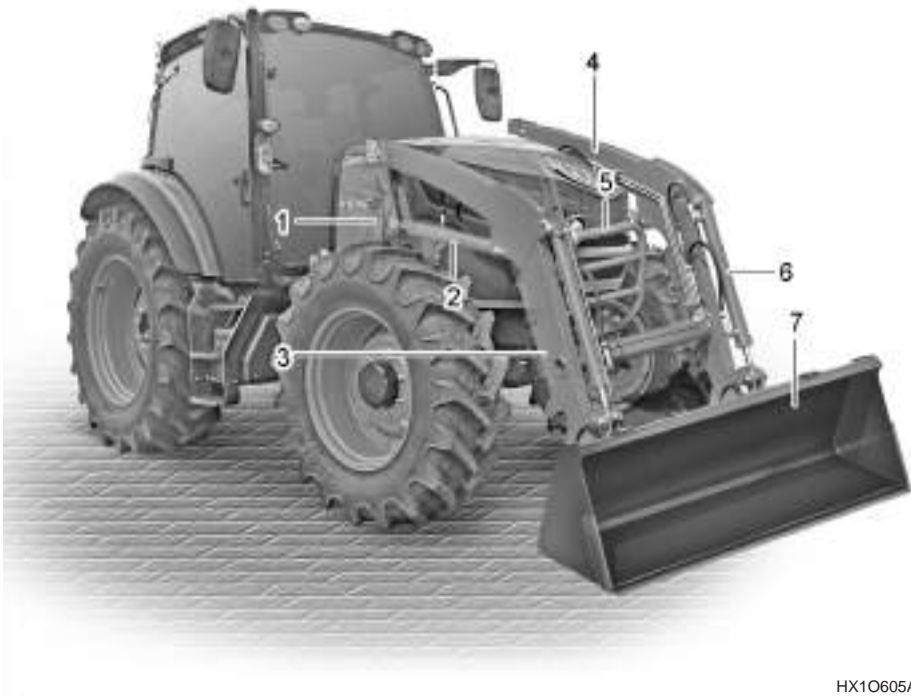

HX1O605A

- (1) Loader Mounting Bracket
- (2) Boom Cylinder
- (3) Loader Arm
- (4) Boom
- (5) Grill Guard
- (6) Tilt Cylinder
- (7) Bucket

For detailed information about installation and use of the front loader, refer to the separate manual of the loader.

### **+** IMPORTANT

- **Check the transmission fluid level and add fluid as necessary after installing an implement.**

### DRIVING ON SLOPE WHEN LOADED BUCKET AND REAR BALLAST ARE INSTALLED

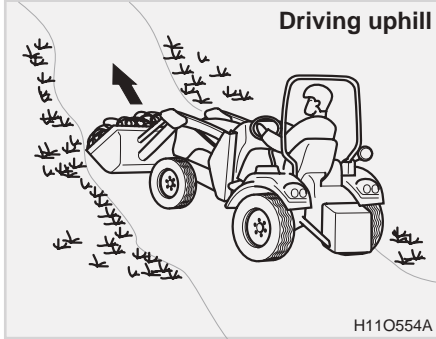

the bucket end of the tractor uphill. In other words, drive forward on uphill and backward on downhill.

#### WARNING

To avoid injuries:

- *Keep the loader arm as low as possible when driving on a slope.*

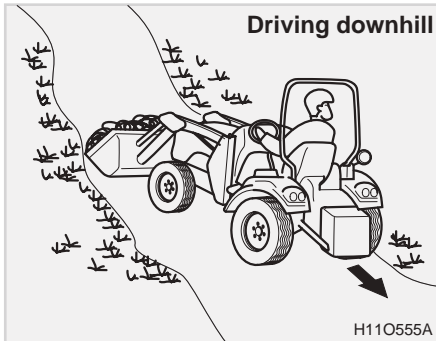

When driving on uphill with the loaded bucket and rear ballast installed, keep

### WHEN UNLOADED BUCKET AND REAR BALLAST ARE INSTALLED



When driving on downhill with the empty bucket and rear ballast in-





### JOYSTICK LEVER

stalled, keep the rear ballast toward the higher level of the ground. In other words, drive backward on uphill and forward on downhill.

Use the 4WD to increase traction when driving on a slope with the loaded bucket and rear ballast installed.

Set the bucket and implement as low as possible for vehicle stability and safety while driving unless there are obstacles on the driving way.



HX1O428C

(1) Joystick Lever

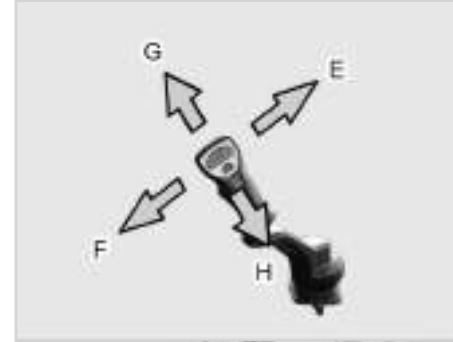

HX1O4J3A

(E) Bucket Roll Back (F) Bucket Dump (G) Boom Down (H) Boom Up

### PARKING WITH LOADER INSTALLED

When parking the tractor which is equipped with a loader or backhoe, make sure that the bucket of loader or backhoe is lowered on the ground.

Otherwise, the tractor can become unstable, leading to an unexpected accident, such as roll over.

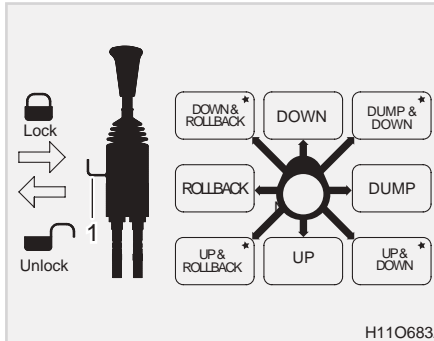

H11O683A

(1) Joystick Lock Lever

E		Bucket Down	F		Bucket Up
G		Boom Down	H		Boom Up

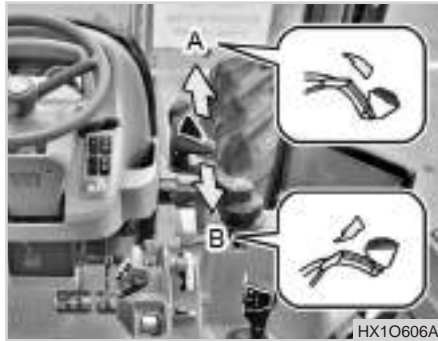

(A) Boom Down (B) Boom Up

### 1. Up and down of boom

Pulling the joystick lever back (B) lifts the boom of the loader while pushing it forward (A) lowers the loader boom.

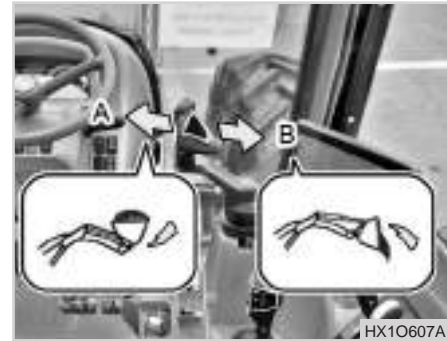

(A) Bucket Roll Back (B) Bucket Dump

### 2. Roll back & dump

"Roll back" means that the bucket scoops up. To operate this function, move the joystick lever to the left (A). "Dump" means that the bucket dumps. To operate this function, move the joystick lever to the right (B).



### 3. Up & roll back

The boom can be lifted and the bucket can scoop up by operating the joystick lever to the rear left position (7 o'clock position). However, these two operations may not be performed simultaneously due to unbalanced hydraulic pressure in the hydraulic circuit.

### 4. Up & dump

The boom can be lifted and the bucket can dump by operating the joystick lever to the rear right position (5 o'clock position). However, the operation time is may not shortened much since the bucket dumps first and then the boom is lifted due to the unbalanced hydraulic pressure in the hydraulic circuit.

### 5. Locking/unlocking joystick

Pressing the joystick lock lever locks the joystick while pulling it outward unlocks the joystick as shown in the figure.

#### WARNING

- ***Make sure to lock the joystick lever while moving. Otherwise, its vibration can cause safety problems, such as falling off of the implement.***
- ***Do not leave the tractor with the boom off the ground in any circumstances. If it is necessary, lock the joystick.***
- ***When the joystick lever is not in use, lock it since the implement can fall down if the lever is operated accidentally.***

#### IMPORTANT

- **If the boom or bucket is not operating, properly, lower the bucket onto the ground, stop the engine, and reduce all hydraulic pressure. Then, check all the hydraulic connections and connect them again.**
- **Before connecting or disconnecting the hydraulic hose coupling for the loader, lower the boom onto the ground, stop the engine, and move the joystick lever front and back, left and right for several times to remove residual pressure in the hydraulic hose.**

 **WARNING*****To avoid accidents:***

- ***Pressurized diesel fuel or hydraulic fluid may be sprayed on your skin or eyes, leading to a severe injury or even death.***
- ***To check leakage, use a board and wear protective gloves and goggles.***
- ***If your eyes come into contact with the hydraulic fluid, seek medical attention immediately.***
- ***Never try to disconnect the tube and quick coupler while the tractor and implement are in operation. Release the pressure by operating the lever after the engine is stopped.***



# MAINTENANCE

# 7

## MAINTENANCE CHECK LIST ..... 7-4

- DAILY CHECK ITEM ..... 7-4
- MAINTENANCE SCHEDULE CHART ..... 7-5
- MAINTENANCE SCHEDULE CHART BY OPERATING HOURS ..... 7-8

## LUBRICANTS ..... 7-10

## DAILY CHECK ..... 7-12

- HOW TO OPEN THE HOOD ..... 7-12
- WALK AROUND INSPECTION ..... 7-12
- CHECKING AND ADDING FUEL ..... 7-13
- CHECKING TRANSMISSION FLUID LEVEL.... 7-14
- CHECKING AND ADDING UREA ..... 7-15
- CHECKING ENGINE OIL LEVEL..... 7-16
- CHECKING COOLANT LEVEL ..... 7-17
- CLEANING GRILL, RADIATOR SCREEN.. 7-18
- CLEANING AIR CONDITIONER CONDENSER ..... 7-19
- CHECKING BRAKE AND CLUTCH PEDALS .... 7-19
- CHECKING GAUGES, METER AND EASY CHECKER ..... 7-19

- CHECKING HEAD LIGHT, HAZARD LIGHT ETC..... 7-19
- CHECKING SEAT BELT AND CABIN ..... 7-19
- ADJUSTING FAN BELT TENSION ..... 7-20
- ALLOWABLE TOLERANCE OF FREE PLAY BETWEEN LH AND RH BRAKE PEDALS..... 7-20
- CHECKING BRAKE PEDALS ..... 7-21
- CHECKING BRAKE OIL ..... 7-21
- BLEEDING BRAKE FLUID LINE..... 7-22
- REMOVING WATER FROM THE FUEL FILTER..... 7-23
- CHECKING AND REPLENISHING UREA TANK..... 7-23

## EVERY 50 HOURS ..... 7-24

- LUBRICATING GREASE LOCATIONS ..... 7-24
- CHECKING WHEEL BOLT / NUT TORQUE ... 7-25

## EVERY 100 HOURS ..... 7-25

- CLEANING AND REPLACING AIR CLEANER FILTER ..... 7-25
- CHECKING AIR CONDITIONER HOSE..... 7-26

## 7



## MAINTENANCE

CHECKING CAB CUSHION RUBBER .....	7-26	CHANGING ENGINE OIL AND REPLACING FILTER .....	7-36
CHECKING FUEL LINES.....	7-27	REPLACING FUEL FILTER.....	7-38
BATTERY .....	7-27	<b>EVERY 800 HOURS .....</b>	<b>7-39</b>
BATTERY SWITCH .....	7-28	REPLACING TRANSMISSION FLUID .....	7-39
ADJUSTING BRAKE PEDAL .....	7-30	<b>EVERY 1,000 HOURS .....</b>	<b>7-40</b>
ADJUSTING AIR CONDITIONER BELT TENSION.....	7-30	<b>EVERY 1 YEARS.....</b>	<b>7-40</b>
CHEKING ENGINE OIL FILTER .....	7-31	REPLACING AIR CLEANER PRIMARY ELEMENT.....	7-40
ADJUSTING FAN BELT TENSION .....	7-31	REPLACING ENGINE OIL AND FILTER ....	7-41
<b>EVERY 200 HOURS .....</b>	<b>7-31</b>	<b>EVERY 2 YEARS.....</b>	<b>7-41</b>
CHECKING RADIATOR HOSE AND CLAMP ...	7-31	FLUSH COOLING SYSTEM AND CHANGING COOLANT .....	7-41
CHECKING INTAKE AIR LINE .....	7-32	ANTIFREEZE .....	7-43
POWER STEERING LINE .....	7-33	REPLACING RADIATOR HOSE AND CLAMP.....	7-43
ADJUSTING TOE-IN.....	7-33	REPLACING POWER STEERING LINE ....	7-43
<b>EVERY 400 HOURS .....</b>	<b>7-34</b>	REPLACING FUEL LINE .....	7-43
CHANGING FRONT AXLE CASE OIL.....	7-34	REPLACING INTAKE AIR LINE .....	7-43
REPLACING TRANSMISSION FLUID AND FILTER.....	7-35		
<b>EVERY 500 HOURS .....</b>	<b>7-36</b>		



**SERVICE AS REQUIRED..... 7-44**

- DRAINING WATER FROM CLUTCH HOUSING ..... 7-44
- REPLACING AIR FILTER ..... 7-44
- CHECK AND CLEAN CAB AIR INTAKE FILTER ..... 7-45
- CHECKING AND REPLACING WIPER ..... 7-47
- REPLACING FUSE ..... 7-49
- REPLACING CABIN FUSE ..... 7-52
- SLOW BLOW FUSE ..... 7-55
- REPLACING BULB ..... 7-56
- CHECKING THE REFRIGERANT ..... 7-62

7

7



## MAINTENANCE CHECK LIST DAILY CHECK ITEM

SERVICE SCHEDULE		Page
ITEM	SERVICE REQUIRED	
Engine Oil	Check the oil level and add as needed. Do not overfill.	7-16
Hydraulic (Trans / Diff.) Fluid	Check level and add as needed.	7-14
Engine Air Filter and Air Intake System	Check restriction indicator. (If equipped) Check for leaks and damaged components. Do not use compressed air to clean elements.	7-32
Engine Cooling System	Clean debris from oil cooler, radiator screen and grills. Check coolant level cold, add premixed coolant as needed.	7-17,41
Seat Belt	Check the condition of seat belt and mounting hardware. Repair or replace as needed.	
Tires	Check for wear, damaged tires and ensure for proper sized tires and correct air pressure.	
Parking Brake	Check operation and adjust if required.	
Clean Pedals	Clean brake pedals, travel control pedal, clutch pedal and footrest area.	7-21
General Items	Check for loose or broken parts, damaged operator cab, instrument operation, loose wheel nuts / bolts, oil leaks and damaged or missing signs. (Decals)	7-12,25
PTO	Inspect the splines. Replaced damaged or missing shields and guards.	
Three-point Linkage	Check operation and condition of pins, links and bars.	
Loader (If Equipped)	Check mounting hardware for loose or broken parts.	

※ For detailed information about maintenance codes, refer to the corresponding section in each chapter.





### MAINTENANCE SCHEDULE CHART

NO.	Item	Maintenance interval	Run hour											Run age		Remarks	Page	
			Initial 50 hours	50	100	200	400	500	600	800	1000	1500	3000	1Year	2Year			
1	Engine oil & Filter	Change	○					○							○			7-36,41
	Transmission oil filter	Replace	○				○											7-36
	Fan belt, Air-con belt	Check	○															
	Clutch pedal free play	Adjust	○		○													
	Brake pedal free play	Adjust	○		○													7-30
2	Engine start system	Check		○														
	Wheel bolt torque	Check		○														7-25
	Greasing	Apply		○														7-24
3	Engine oil & Filter	Check			○													7-31
	Battery condition	Check			○												* 3	7-27
	Fuel line	Check			○												#	7-27
	PTO shaft and guard condition	Check			○													
	3 point hitch and draw-bar condition	Check			○													
	Secure pins	Check			○													
	Tire pressure and damage	Check			○													



NO.	Item	Maintenance interval	Run hour											Run age		Remarks	Page	
			Initial 50 hours	50	100	200	400	500	600	800	1000	1500	3000	1Year	2Year			
3	Parking brake condition	Check			○													
	Fan belt, Air-con belt	Adjust			○												* 3	7-30,31
	Air cleaner element	Clean			○												* 1 #	7-25
4	Radiator hose and clamp	Check				○												7-31
	Power steering hose and oil line	Check				○												7-33
	Intake air hose	Check				○												7-32
	Toe-in	Adjust				○												7-33
5	Front axle oil	Change					○											7-34
6	Fuel filter element	Replace						○									#	7-39
7	Transmission fluid	Change							○									7-39
8	Engine valve clearance	Adjust								○								7-40
9	Fuel injection nozzle Injection pressure	Check									○						#	
10	Urea pump filter	Replace										○					* 4	
	Injection pump	Check										○					#	
11	Air-con filter	Replace											○					
	Air cleaner element	Replace											○			* 2 #	7-40	



NO.	Maintenance interval		Run hour											Run age		Remarks	Page		
			Initial 50 hours	50	100	200	400	500	600	800	1000	1500	3000	1Year	2Year				
12	Coolant	Replace															○		7-41
	Radiator hose and clamp	Replace															○		7-43
	Power steering hose and oil line	Replace															○		7-43
	Fuel line	Replace															○	#	7-43
	Intake air hose	Replace															○	* 3	7-43
	Cooling system	Clean															○		7-41
13	Fuel system	Check																* 3	
	Fuse	Replace																* 3	7-49
	Light bulb	Replace																* 3	7-56

**⊕ IMPORTANT**

- The symbol of the remark follows.
  - \* 1 Air cleaner should be cleaned more often in dusty conditions than in normal condition.
  - \* 2 Every year or every 5 times of cleaning.                      \* 3 Replace only if necessary.                      \* 4 Every 3 year
- The items listed above (# marked) are registered as emission related critical parts by KIOTI in U.S. EPA exhaust emission standard non-road emission regulation. As the engine owner, you are responsible for the performance of the required maintenance on the above instruction.
- Engine should be operated, used and maintained in accordance with the owner's manual in order to maintain the emissions performance of the engine.



### MAINTENANCE SCHEDULE CHART BY OPERATING HOURS

Run Hour	Check List												
	1	2	3	4	5	6	7	8	9	10	11	12	13
50	○	○											
100		○	○										
150		○											
200		○	○	○									
250		○											
300		○	○										
350		○											
400		○	○	○	○								
450		○											
500		○	○			○							
550		○											
600		○	○	○									
650		○											
700		○	○										
750		○											
800		○	○	○	○		○						
850		○											
900		○	○										
950		○											
1000		○	○	○		○		○					
1050		○											
1200		○	○	○	○								
1250		○											
1300		○	○										
1350		○											
1400		○	○	○									
1450		○											
1500		○	○			○				○			
1550		○											
1600		○	○	○	○			○					
1650		○											
1700		○	○										
1750		○											
1800		○	○	○									
1850		○											
1900		○	○										



## LUBRICANTS

To prevent serious equipment damage, use only genuine **KIOTI** fluids, oils and greases, or equivalents.

NO.	SECTION	CAPACITY [U.S.gal. (L)]	LUBRICANTS
1	Fuel	47.6 (180)	Ultra-low sulfur diesel (Sulfur content: 15 ppm or less)
2	Coolant	HX9010/1001: 4.6 (17.4) HX1151/1201: 4.7 (18.0)	An antifreezing solution(Ethylene glycol) + Pure water (50 : 50)
3	Engine oil (Filter Included)	3.9 (15)	API CJ4 SAE 10W30
4	Urea	4.7 (18)	Urea solution approved by Ministry of Environment (according to ISO 22241)
5	Transmission oil	20.34 (77)	Daedong : S-UTF 38 Exxonmobil : Mobilfluid 350 Shell : Donax-TD Low Vis BP : AUTRAN SYN 29 Petro-Canada : Duratran XL Synthetic Blend
6	Front axle oil	2.6 (10.0)	Gear Oil(SAE 90) ZIC G-EP 80W-90 or equivalents
7	Front axle case (LH, RH)	0.2 + 0.2 (0.9 + 0.9)	
8	Brake oil	0.12 (0.47)	ZIC Super Vis AW68, Shell Tellus S2 M 68 or Shell Tellus S2 MX 68
9	Grease - Ref to "Grease fitting location" in chapter 7.	Until grease comes out from gaps	SAE multi-purpose type grease Universal joint: MOLYKOTE G-1011

**⚠ WARNING**

- ***Check the oil level periodically. Correct the oil level, if needed, before operating.***
- ***Always check and add oil with the tractor on a flat, level surface.***
- ***Do not deliberate tampering with or misuse of the engine emissions control system; in particular with regard to deactivating or not maintaining an exhaust gas recirculation (EGR).***
- ***Engine should be promptly rectified any incorrect operation, use or maintenance fo the emissions control system.***
- ***Using poor fuel can be damaged on high pressure pump and injectors.***
- ***Use the follwing fuel to maintain the performance of the emissions control system. Fuel with Sulphur content not greater than 10mg/kg, cetane number not less than 45 and FAME content not greater than 8% v/v shall be used.(EU model)***

## DAILY CHECK HOW TO OPEN THE HOOD

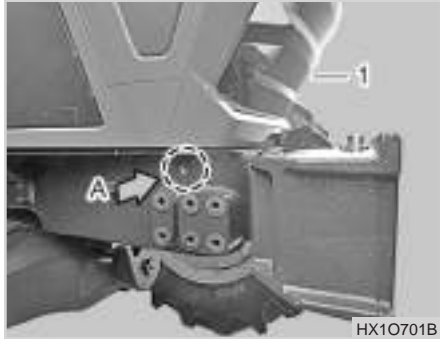

(1) Opening Knob  
(A) Push

1. To open the hood, while pushing down and holding the front section of the hood, press the open button in its right lower section, and then lift the hood up.
2. To close the hood, press down the front section of the hood until it is locked into its original position.
3. Do not apply excessive force to the lever to fix the hood. The hood can be damaged.



(1) Hood

### ⚠ CAUTION

- Never open the hood while the engine is running.

### 📖 NOTE

- If noise is produced from the hood during driving, check its rubber molding. If damaged, replace it.

## WALK AROUND INSPECTION

For your own safety and maximum service life of the machine, make a thorough daily inspection before operating the machine to start the engine.

### ⚠ CAUTION

To avoid personal injury:

- Turn off the engine, apply the parking brake, and perform inspection and maintenance on a level ground.

Look around and under the tractor for items such as loose bolts, trash build-up, oil or coolant leaks, broken or worn parts.





## CHECKING AND ADDING FUEL



(1) Fuel Tank Cap

The fuel tank cap is automatically locked as it is tightened. To fuel, unlock the cap with the ignition key before opening it.

### WARNING

- ***Make sure to use pure and high-quality diesel fuel.***

### Fuel Tank Capacity

47.6 U.S.gal. (180 L)

1. Turn the key switch to "ON", check the amount of fuel by fuel gauge.
2. If the needle on the fuel gauge is close to "E" or the fuel level is low, open the fuel tank filler cap and add the fuel.
3. After adding the fuel, close the fuel tank filler cap.

### CAUTION

To avoid personal injury :

- **Do not smoke while refueling.**
- **Add the fuel in a well-ventilated area.**
- **Be sure to stop the engine before refueling.**
- **Dirt or sand contained in fuel may cause the fuel injection pump to malfunction, use the strainer when refuelling.**

### IMPORTANT

- **Be careful not to spill during refueling. If a spill occur, wipe it off at once, or it may cause a fire.**
- **If unit is not used for a long time, make sure the fuel viscosity is suitable for the cold weather.**

## CHECKING TRANSMISSION FLUID LEVEL

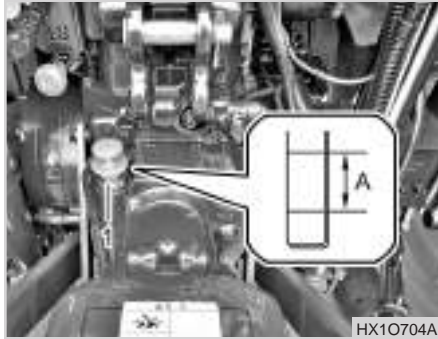

(1) Oil Dipstick  
(A) Oil level is acceptable within range

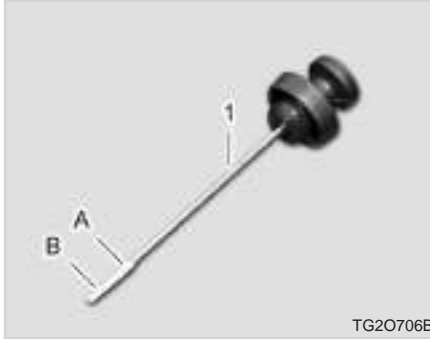

(1) Oil Dipstick  
(A) Upper Limit (B) Lower Limit

1. Park the machine on a flat surface, lower the implement and shut off engine.
2. Depress the brake pedals and apply the parking brake.
3. Set all shift levers into the neutral position.
4. Stop the engine.

5. Pull out the oil dipstick, clean it, and then insert it into its original position. Then, pull it out again and check if the oil level is within the specified range.
6. If the oil level is too low, add some new oil so that the level is within the allowable range. (Refer to "Lubricant" in this chapter for fluid specs)

### ⊕ IMPORTANT

- If oil level is low, do not run engine.
- Never add the oil over the upper limit.
- Be sure to check the oil level after installing hydraulic implement. Add the fluid as needed.
- Check the oil level with the cylinders of an implement extended and check again with cylinders retracted. Add the oil to adjust average oil level in the range of the oil limit. (Upper or lower)



## CHECKING AND ADDING UREA



(1) Urea tank (2) Urea level gauge  
(A) Proper urea level

The urea tank is located in the left section of the vehicle body. As the urea is used to reduce nitrogen oxide, add it to the tank periodically.

### 1. Purpose

It is used to convert the exhaust gas into harmless nitrogen and water in order to reduce the emissions and enhance the fuel efficiency.

### 2. Capacity

3 - 5 liters of urea is used for 100 liters of fuel based on the standard work load. Therefore, carry extra urea always and add it when necessary. (Approx. 8 - 10 liters of urea is consumed while 200 liters of fuel is consumed. - Urea tank capacity: 20 liters.)

### ⚠ WARNING

- **Use the genuine urea only according to ISO 22241 with approval of Ministry of Environment.**
- **The aftertreatment system can be damaged if homemade urea solution is used, urea is diluted or substance other than the urea is used.**





### ⚠ CAUTION

- **Never make the urea solution on your own. Use the genuine urea (Urea, DEF, AdBlue, AUS32) only according to ISO 22241 with approval of Ministry of Environment. It is available at gas stations and on the Internet.**

### 3. Symptoms for low urea level

When the urea level is low, the corresponding warning lamp on the instrument cluster turns on. If urea is not added under this condition, the engine power is derated, making the machine inoperable.

<Make sure to add urea if this lamp comes on.>

Level	Countermeasures	
Step 1	 DEF	ON
Step 2	 DEF	  After blinking, the engine power is derated.

### ⚠ CAUTION

- If the urea level is dropped to a certain level, but additional urea is not added into the tank, the engine power is derated, and the engine can run only at a low idling speed.
- If the urea level warning lamp turns on, add urea into the tank immediately.
- If adding non-genuine urea, diluted urea or other substance into the urea tank, the power can be derated and the system can be damaged.

When the ignition switch is turned to the OFF position, the urea pump returns any urea remained in the line back to the tank. During this process, a cracking noise can be heard. Never disconnect the battery cable during this process.

To protect the turbocharger, 3 to 4 seconds of delay may occur until the speed starts to rise even when the accelerator dial is set to the maximum value after the initial start of the engine.

If the automatic acceleration function is turned on, the engine rpm cannot be increased by turning the accelerator dial. The engine rpm can be increased under the specified condition.

## CHECKING ENGINE OIL LEVEL

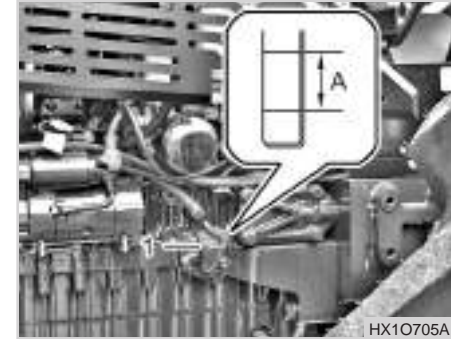

(1) Oil Dipstick

(A) Oil Level is Acceptable Within This Range

1. Check the engine oil daily.
2. Park the tractor on a level ground and lower the implement.
3. If the engine was just running, wait for approx. 5 minutes before checking the oil level.

### ⚠ CAUTION

To avoid personal injury :

- Be sure to stop the engine before checking the oil level.

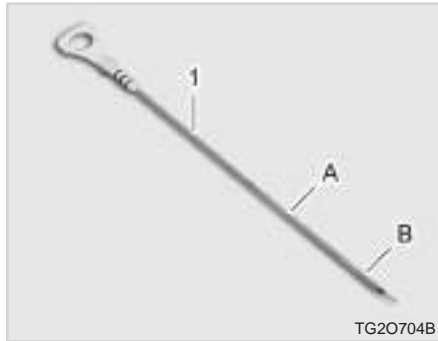

(1) Oil Dipstick  
(A) Upper Limit (B) Lower Limit

4. Pull out the oil dipstick, clean it, and then insert it into its original position. Then, pull it out again and check if the oil level is within the specified range.
5. If the oil level is too low, add some new oil so that the level is within the allowable range.

### ⊕ IMPORTANT

- When using oil of different maker or viscosity from the previous one, remove all of the old oil. Never mix two different types of oil.
- Do not start the engine when the oil level is below lower limit.
- Wipe the oil dipstick with clean cloth or tissue. If foreign material enters the oil sump, it can lead to malfunction of the engine.
- Never add the oil over the upper limit.

## CHECKING COOLANT LEVEL



(1) Reservoir Tank  
(A) MIN (Lack)

1. Check to see that the coolant level is at the "MIN" or higher level of the reservoir tank.
2. When the coolant level drops due to evaporation, add water only up to the "MIN" mark or higher level of the reservoir tank. In case of leakage, add anti-freeze and water in the specified mixing ratio up to the "MIN" mark or higher level.



## CLEANING GRILL, RADIATOR SCREEN

3. The tractor is furnished in the factory with a mixture of anti-freeze (ethylene glycol) and water in a ratio of 50 : 50 which is usable in any season.

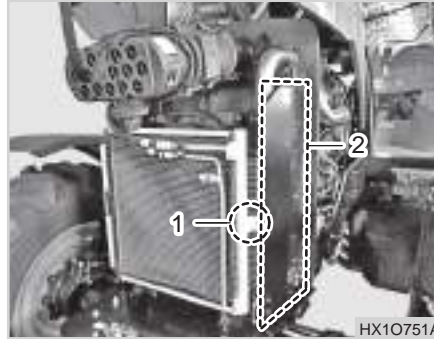

- (1) Radiator Screen      (2) Bolt  
 (3) Net  
 (A) Open                      (B) Detach

1. Check front grill and side screens to be sure they are clean of debris.
2. Loosen the bolt and open the blocking plate.
3. Lift out the radiator screen and remove all the foreign material.

### CAUTION

**To avoid accidents :**

- **Be sure to stop the engine before removing the screen.**

### IMPORTANT

- **Bonnet Grill and screen must be clean from debris to prevent engine from overheating and to allow good air intake for the air cleaner.**



## CLEANING AIR CONDITIONER CONDENSER

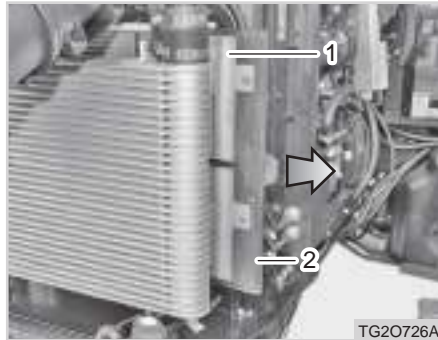

(1) Condenser      (2) Net

1. Open the hood.
2. Remove the net and clean it.

### CAUTION

- Make sure to stop engine when checking. If cooler fan is blocked by dirt, clean with a soft brush or cloth using tap water.

## CHECKING BRAKE AND CLUTCH PEDALS

1. The brake and clutch pedals should be inspected for free travel, and smooth operation.
2. You should adjust these pedals if an incorrect measurement is found. (Refer to the instructions for adjusting the clutch and brake pedals in the Chapter Maintenance.)

### NOTE

- When depressing the brake pedals separated, both of the brake pedals should be moved down to the same depth.

## CHECKING GAUGES, METER AND EASY CHECKER

1. Inspect the instrument panel for broken gauge (s), meter (s) and Easy Checker lamps.
2. Replace if broken.

## CHECKING HEAD LIGHT, HAZARD LIGHT ETC.

1. Inspect the lights for broken bulbs and lenses.
2. Replace if broken.

## CHECKING SEAT BELT AND CABIN

1. Always check condition of seat belt and attaching hardware before operating tractor.
2. Replace if damaged.

## ADJUSTING FAN BELT TENSION

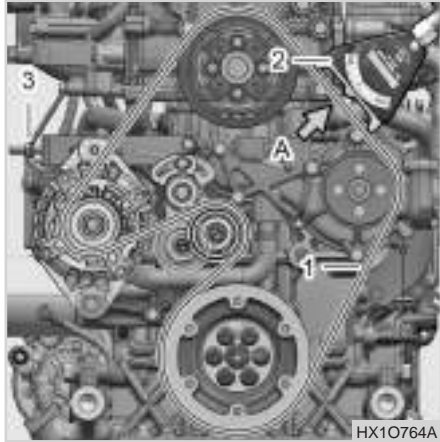

(1) Fan Belt (2) Tension Gauge  
(3) Tension Adjustment Nut  
(A) Tension Measurement Area

In order to extend the fan belt's life-time, the tension of the belt should be correctly adjusted if it slips. The belt tension should be inspected regularly according to the following procedure :

1. Stop the engine and apply the parking brake.
2. Open the hood.

3. Measure the belt tension at the tension measurement area (A) with a tension gauge.

Belt deflection for proper fan belt tension (A)	
When replacing a new belt	750 ± 50N or more when measured with a Denso tension gauge
When adjusting	550 ± 50N or more when measured with a Denso tension gauge

4. If the tension is insufficient, turn the tension adjusting bolt clockwise to adjust the tension to the standard tension range.
5. Replace the fan belt if it is damaged, cracked or worn.

### CAUTION

**To avoid personal injury :**

- **Be sure to stop the engine before checking belt tension.**

## ALLOWABLE TOLERANCE OF FREE PLAY BETWEEN LH AND RH BRAKE PEDALS

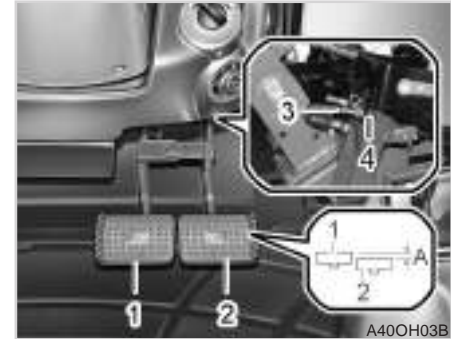

(1) Brake Pedal (LH) (2) Brake Pedal (RH)  
(3) Adjusting Bolt  
(A) Free play difference between brake pedals

1. Slightly depress the LH and RH pedals separately and measure the free play of both pedals.
  2. If the difference between two pedals' free play is out of the specified value, adjust the free play with the bolt.
- Tighten the mounting nut firmly after adjustment.

### Free play difference between brake pedals (LH, RH)

Less than 0.276 in. (7 mm)





## CHECKING BRAKE PEDALS

1. The brake pedals should be inspected for free travel, and smooth operation.
2. You should adjust this pedal if an incorrect measurement is found.

### NOTE

- When checking the brake pedals separated, both of the brake pedals should move down to the same depth.

## CHECKING BRAKE OIL

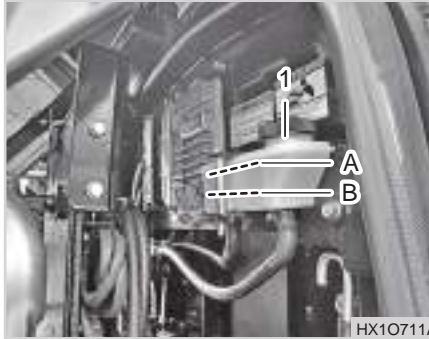

HX10711A

*(1) Brake oil tank**(A) High level**(B) Low level*

Add brake oil before the oil level reaches the lower level limit.

### CAUTION

- After maintenance or repair, be sure to bleed the air from the brake system.
- Air in the unit can “blunt” the brake pedal and cause brake failure.

### CAUTION

- Never drive the tractor if the brake oil is not at the proper level.
- Use only KIOTI approved brake fluid.

## BLEEDING BRAKE FLUID LINE

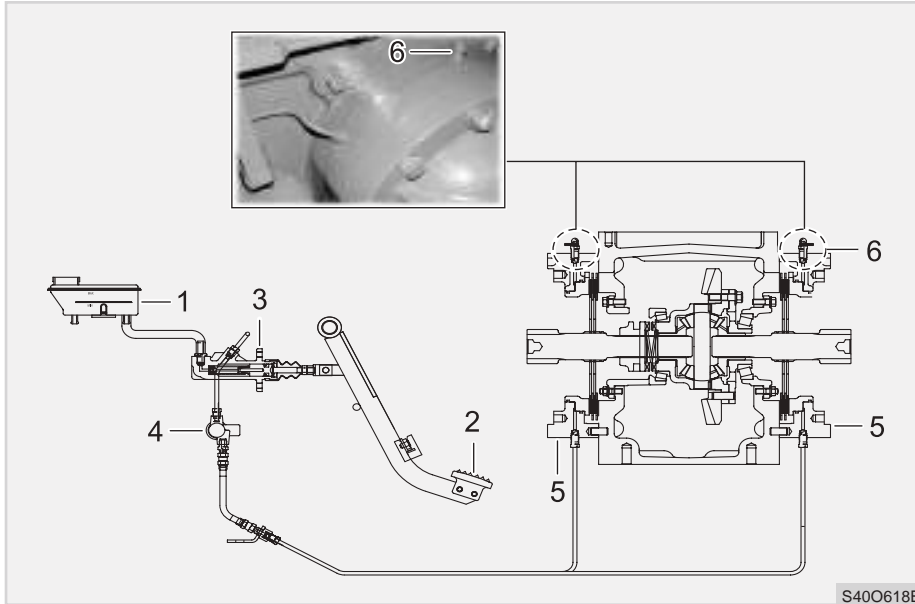

1. Add the brake fluid to the brake fluid tank (1) up to the upper limit.
2. Unscrew the bleeder (6) of the brake case (5) for a half turn.
3. Install a transparent plastic hose to the bleeder of the brake case (5) to collect the fluid.
4. Repeat depressing and releasing the brake pedal (2) slowly. Replenish the brake fluid tank (1) with fluid so that it does not get empty.
5. Repeat the step 4 until there is no air bubble coming out from the bleeder.

6. After bleeding is completed, tighten the bleeder with the brake pedal (2) depressed.
7. Bleed the other side of brake line by repeating the steps from 2 to 6.
8. The fluid level of the brake fluid tank (1) should be at the upper limit after bleeding the line.

### Brake Fluid Capacity

0.12 U.S.gal. (0.47 L)

### **⚠ WARNING**

- *The KIOTI genuine brake fluid is mineral oil based fluid. Never use vegetable oil-based fluid for automobile.*



## REMOVING WATER FROM THE FUEL FILTER



(1) Fuel filter

(2) Drain tap

1. Water and dust in fuel are accumulated in the filter. Undo the drain tap from the bottom of the fuel filter to drain any impurities.
2. After draining, tighten the it with a hand. (Do not use a tool.)
3. Start the engine, and check for fuel leakage.

## CHECKING AND REPLENISHING UREA TANK

The urea tank is located in the left side of the vehicle. Its purpose is reduction of NOx and urea should be added to the tank regularly.

### WARNING

- *Make sure to use genuine urea according to ISO 22241 approved by Ministry of Environment.*
- *Using self-produced or diluted urea or other substance instead can damage the after treatment system.*

### CAUTION

- **Urea is soluble liquid used to reduce NOx. As it is injected into emission stream during operation of the tractor, it needs to be added to the tank regularly.**
- **When adding urea to the tank, make sure that it is not mixed with diesel fuel and foreign materials.**

### CAUTION

- **If the urea level is dropped below a certain level, the engine power can be dropped and the engine can be operated only at the low idle speed.**
- **Make sure to add urea to the tank as soon as the low urea level warning lamp comes on.**

## EVERY 50 HOURS LUBRICATING GREASE LOCATIONS

Apply high-quality multi-purpose grease onto the positions in the figure at every 50 hours of operation or whenever necessary and record the operating time when applying it.



(1) Front Bracket Axle Pivot

HX10712A



(1) Bevel Gear Case, LH/RH

HX10759A



(1) Bracket, Front axle support

HX10714A



(1) Lift Arm, LH/RH

HX10765A



(1) Top Link

(2) Holder, Top Link

HX10766A

### ⊕ IMPORTANT

- Perform the maintenance service every 10 hours of operation when working in damp or muddy conditions.
- Before applying grease, clean the area around the application spots thoroughly. If any application part is damaged, replace it with a new one immediately.



## CHECKING WHEEL BOLT / NUT TORQUE



(1) Front Wheel Bolt / Nut  
(2) Rear Wheel Bolt / Nut

Check wheel bolts and nuts regularly especially when new. If they are loose, tighten them as follows.

Item		Tightening Torque
Front wheel	Nut	28~32.5 kgf·m
	Bolt	28~34 kgf·m
Rear wheel	Nut	37.5~44 kgf·m

### ⚠ CAUTION

To avoid personal injury :

- Never operate tractor with a loose rim, wheel, or axle.
- Any time bolts and nuts are loosened, retighten to specified torque.
- Check all bolts and nuts frequently and keep them tight.

## EVERY 100 HOURS CLEANING AND REPLACING AIR CLEANER FILTER

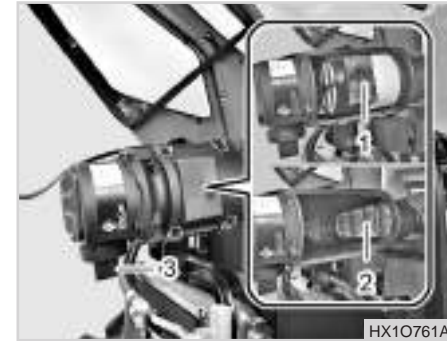

(1) Element Assembly (2) Filter Assembly  
(3) Evacuator Valve

If the air cleaner is not in a good condition, the lifetime of the engine can be shortened, excessive soot can be produced, and the engine power can be deteriorated. Therefore, the filter should be inspected frequently. Its replacement interval can be changed according to driving conditions. Replace the filter according to the following procedure :

1. Open the hood and check the air cleaner housing for damage.



2. Release the air cleaner clip and remove the front cover.
3. Clean the inside of the air cleaner housing by blowing compressed air through it.
4. Replace the element assembly check the housing for damage. (Replace filter assembly if necessary.)
5. Install the front cover and fix it with the clip.

 **NOTE**

- When installing the cover, make sure that the dust collection valve is heading down.

 **CAUTION**

- **Use only a genuine filter. Use of a non-recommended filter can cause damage to the engine and sensor.**
- **Make sure that no dust enters the system by installing the cover firmly.**
- **When removing the filter, be careful not to let foreign material enter the air inlet.**
- **The mass air flow sensor is installed behind the air cleaner. Therefore, do not apply compressed air into the air cleaner housing with the secondary filter (safety filter) removed.**

**CHECKING AIR CONDITIONER HOSE**

Check the linkage and damage of the air conditioner hose and pipe.

**CHECKING CAB CUSHION RUBBER**

Check the damage of the cab cushion rubber.



## CHECKING FUEL LINES

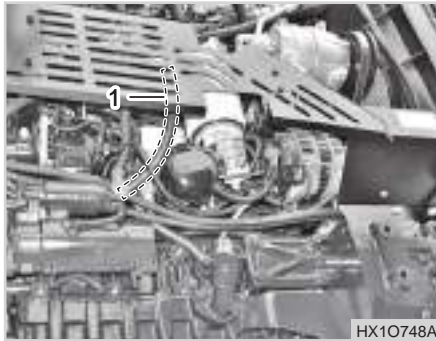

HX10748A

(1) Fuel Hose

Although checking the fuel pipe connection is recommended every 100 service hours, it should be done every 6 months if operation does not exceed 100 hours in 6 months.

1. If the hose clamps are loose, apply a slight coat of lubricant onto the threads and securely tighten it.
2. The fuel pipe is made of rubber and ages regardless of period of service. Change the fuel pipe together with

the hose clamps every two years and securely tighten.

3. If the fuel pipes and hose clamps are found damaged or deteriorated earlier than two years, then change them immediately.

### ⚠ WARNING

- **Stop the engine when checking the items above.**
- **The fuel pipes are subject to wear and aging. Failure to perform periodic inspections may lead to a fuel leak. Fuel leaking on a hot engine could cause a fire.**

### ⊕ IMPORTANT

- **When changing fuel pipes, be careful not to allow dust or dirt to enter the fuel system. Contaminations in the fuel system could damage the fuel system or injection pump. Pay extra caution to the fuel pump to prevent dust from entering it.**

## BATTERY PRECAUTIONS FOR HANDLING



HX10722A

(1) Battery

(2) Battery Switch

It is important to inspect the battery periodically.

1. The battery cable should always be clean and firmly connected. When installing a new or used battery, clean its terminals.
2. Check the battery and cable for damage and corrosion.
3. Apply grease to the terminals and cable end in order to prevent corrosion.

### ⚠ WARNING

- **The battery gas can explode. Do not expose the battery to flames or sparks. It may cause a fire.**
- **The battery fluid contains sulfuric acid that can burn you. Do not allow the battery fluid to contact your eyes, skin, or painted surfaces. If you accidentally get it in your eyes or on your skin, flush with water and seek immediate medical attention.**
- **Be sure to wear eye protection while working on the battery. The battery fluid can hurt your eyes.**
- **Use only the battery with the specified voltage. Otherwise, it may cause a fire.**

## BATTERY SWITCH

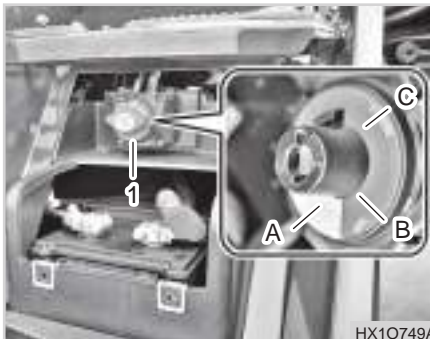

(1) Battery Switch  
 (A) Power Off (Off)    (B) Power Supply (On)  
 (C) Remove The Handle

When the battery switch is set in the "OFF" position, power is blocked. When it is in the "ON" position, power is supplied. Set the switch in the "OFF" position for long-term storage.

### ⚠ CAUTION

- **Set the battery switch in the "OFF" position or disconnect the battery cable in approx. 2 minutes after stopping the engine.**
- **Urea return function is performed and the ECU/DCU is energized for approx. 2 minutes after the engine is stopped. Therefore, wait for approx. 2 minutes before disconnecting the battery.**





## CHARGING

Contact the battery dealer for proper charging instruction.

### CAUTION

- **The charge warning lamp comes on if the charging system is defective. If it comes on while driving, have the system checked or repaired by your local KIOTI Dealer.**
- **Keep the battery fully charged. If the battery fluid concentration is too low during the winter season, the battery may be frozen.**
- **Do not start the engine when the battery is frozen. Try to warm it up first.**
- **If the battery is not securely installed, the battery case and electrolytes could be damaged by vibration. To prevent the battery acid from contacting the terminals, apply grease around the battery terminals and connections.**

### CAUTION

- **Never check the charge status of the battery by placing a metal object across the posts. Use a voltmeter or hydrometer.**

## DIRECTION FOR STORAGE

1. When storing the tractor for a long period, remove the battery from tractor, store in a dry place out of direct sunlight.
2. The battery self-discharges while it is stored.

Recharge it once every three months in hot seasons and once every six months in cold seasons.

## ADJUSTING BRAKE PEDAL BRAKE PEDAL FREE PLAY

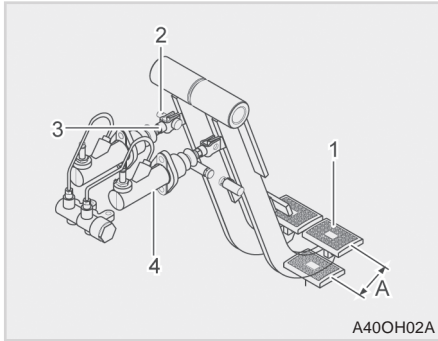

- (1) Brake Pedal      (2) Push Rod  
(3) Lock Nut        (4) Master Cylinder  
(A) Free Play

1. Slightly depress the brake pedal and measure its free play.
2. If the free play is out of the specification, adjust the length of the push rod.
3. Tighten the lock nut firmly after adjustment.

### Pedal Free Travel (A)

0.591 ~ 1.181 in. (15~30 mm)

### ⚠ WARNING

- Make sure that the push rod does not push the piston with the pedal released.

## ADJUSTING AIR CONDITIONER BELT TENSION

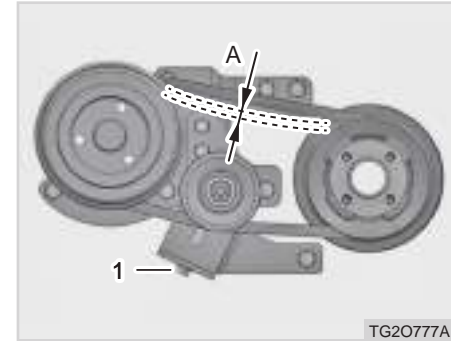

- (1) Adjusting Bolt  
(A) Adjusting Belt Tension

1. Stop the engine and apply the parking brake.
2. Press the belt between the pulley with force of 9.92 lbs. (4.5 kgf) and adjust the belt tension according to the below specification.

### Tension of air conditioner belt (A)

When press the middle point of the belt :  
0.39 in. (10 mm)



3. Replace the damaged belt.

 **CAUTION**

- Stop the engine before checking air conditioner belt.

### CHEKING ENGINE OIL FILTER

1. See pages 7-37.

### ADJUSTING FAN BELT TENSION

1. See pages 7-20.

### EVERY 200 HOURS CHECKING RADIATOR HOSE AND CLAMP



(1) Radiator Hose (2) Clamp

Check to ensure the radiator hoses are free from damage and are tightened properly every 200 hours or every 6 months, whichever comes first.

1. If the hose clamps are loose or water leaks from hose, tighten clamps securely.
2. If the radiator hoses are swollen, hardened, cracked, or otherwise damaged, you must replace the hoses. Failure to do so could lead



to coolant loss and engine damage. Never perform work while engine is hot.

**PRECAUTION AT OVERHEATING**  
Take the following actions in the event the coolant temperature reaches the boiling point, what is called "Over-heating".

1. Stop the machine in a safe place and keep the engine idling.
2. After 5 minutes of unloaded idling, shut the engine down.
3. Keep yourself away from the tractor for another 10 minutes or until steam has stopped blowing out of the engine.
4. Make sure that there is not danger and repair the cause of the over-heating according to the manual's instruction. (Make sure to refer to "Engine troubleshooting" in chapter 8 before starting the engine)

## CHECKING INTAKE AIR LINE



(1) Air Line Hose

1. If the hose clamps are loose , tighten clamps securely.
2. If the hoses and clamps are damaged, you must replace them at once. Failure to do so could lead to engine damage.



## POWER STEERING LINE



(1) Power Steering Oil Line

1. Check to see that all hydraulic lines and hose fittings are tight and undamaged.
2. If damage is found you should replace the hose at once.

## ADJUSTING TOE-IN ADJUSTING PROCEDURE

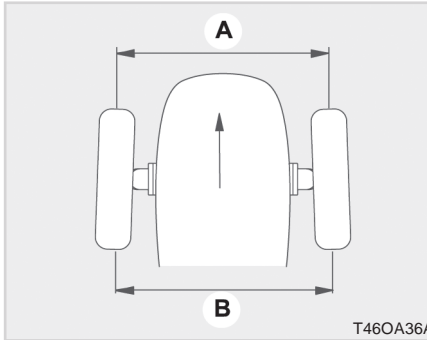

- (A) Wheel - to - wheel distance at front  
(B) Wheel - to - wheel distance at rear

1. Park tractor on a flat place
2. Turn steering wheel so front wheels are pointed straight ahead.
3. Lower the implement, lock the parking brake and stop the engine.
4. Measure distance between tire beads (center) at front of tire and hub height.

5. Measure distance between tire beads at the rear of tire and hub height.
6. Front distance should be 0.08~0.31 in. (2~8mm) less than rear distance. If not, adjust ball joint length



## EVERY 400 HOURS CHANGING FRONT AXLE CASE OIL

### READJUSTMENT



(1) Tie Rod Lock Nut      (2) Tie Rod

1. Loosen the lock nut and turn the turnbuckle to adjust the rod length until the proper toe-in measurement is obtained.
2. Check the toe-in value after the tie rod is adjusted.
3. Adjust it again if necessary.



(1) Oil Filler Plug      (2) Checking Oil Plug  
(3) Drain Plug

1. To drain the used oil, remove the right and left drain plugs and filling plug at the front axle case and drain the oil completely into the oil pan.
2. After draining, reinstall the drain plugs.
3. Remove the oil level checking plug on the left of the front axle.

4. Add new oil to the specified level through the oil filler.
5. Wait at least 15 minutes to allow the oil flow to the bevel case before checking the oil level.
6. Add oil as necessary and tighten the oil filler plugs and oil level checking plug.

#### Front Axle Oil Capacity

2.6 U.S.gal. (10 L)



## REPLACING TRANSMISSION FLUID AND FILTER



(1) Oil Filter Cartridge

The transmission fluid should be changed if it is contaminated or after the transmission is serviced or every 800 hours of operation. When changing the transmission fluid, make sure to change the fluid filter. However, replace the filter only at initial 50 hours and every 400 hours operation afterward.

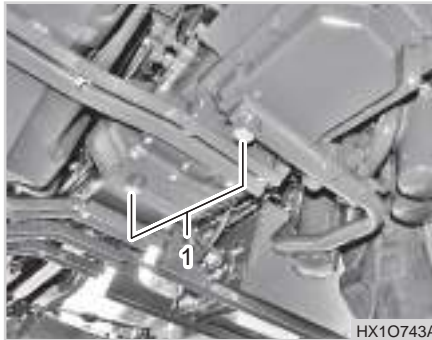

(1) Drain Plug

1. Park the tractor on a level ground and start the engine to warm it up.
2. Stop the engine, apply the parking brake, and remove the drain plug.
3. To drain the used fluid, place the oil container under the transmission case and remove the drain plug to drain used fluid. If the fluid does not flow out freely, unscrew

1. Park the tractor on a level ground and start the engine to warm it up.
2. Stop the engine, apply the parking brake, and remove the drain plug.
3. To drain the used fluid, place the oil container under the transmission case and remove the drain plug to drain used fluid. If the fluid does not flow out freely, unscrew the breather plug on the top of the hydraulic cylinder on the behind of the top link bracket to facilitate drainage. (Ref to next page)

Reinstall the drain plugs securely afterward.

4. Unscrew the fluid filter from the rear right section on the tractor using a filter wrench.

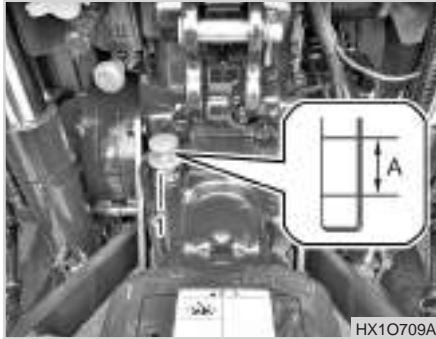

(1) Oil Dipstick  
(A) Oil level is acceptable within this range

5. Apply a thin film of clean oil onto the O-ring of a new filter.
6. Tighten the filter firmly by hand.
7. Run the engine for a few minutes and then stop it to check the leakage and fluid level. Add fluid to the specified level as needed.

**Transmission Oil Capacity**

20.34 U.S. gal. (77 L)

**CAUTION**

To avoid personal injury :

- Be sure to stop the engine before changing the fluid or replacing the filter.
- Cool down the fluid sufficiently. You can get burned by hot fluid.

**IMPORTANT**

- To prevent serious damage to the hydraulic system, use only a KIOTI genuine filter.
- Do not operate the tractor with heavy load right after changing the transmission fluid. Run the engine at medium speed for a few minutes to prevent damage to the hydraulic system.

**EVERY 500 HOURS  
CHANGING ENGINE OIL AND  
REPLACING FILTER**

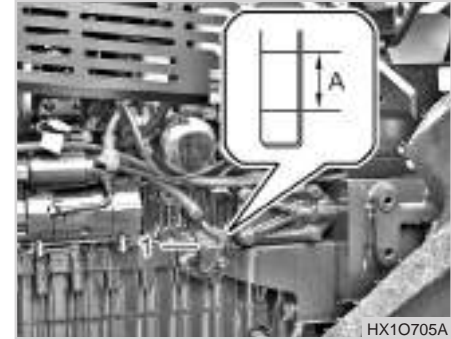

(1) Oil Dipstick  
(A) Oil level is acceptable within this range

1. Park the tractor on a level ground and start the engine to warm it up.



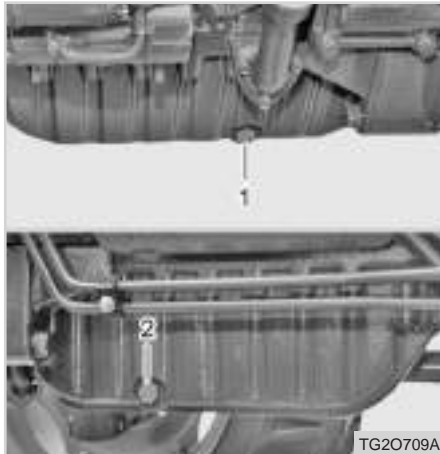

(1) Drain Plug (RH) (2) Drain Plug (LH)

2. Stop the engine, apply the parking brake, and remove the drain plug.
3. Remove the drain plug at the bottom of the engine and drain the oil completely. All the used oil can be drained out easily when the engine is still warm.

Be sure to put the drain plugs to the oil sump securely.

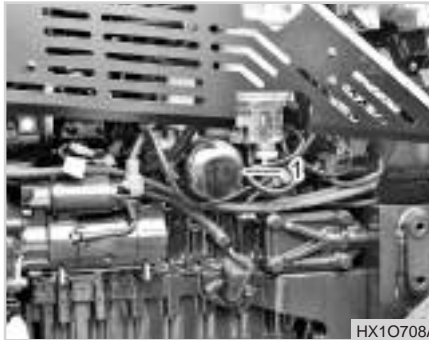

(1) Engine Oil Filter

4. Remove the oil filter behind the cooling fan on the right side of the engine.
5. Apply a thin film of oil to the O-ring of a new filter and tighten the O-ring firmly by hand.
6. Fill the engine oil to the specified level and tighten the oil filler cap.

#### Engine Oil Capacity (Filter Included)

3.9 U.S.gal. (15 L)

7. Run the engine for approx. 5 minutes to deliver oil to each part.
8. Engine oil light should go off after 10 seconds of running. If the oil pressure light stays on, stop the engine.
9. Check the engine oil level again with the oil dipstick. If the level is low, add more oil.

#### NOTE

- The engine oil filter should be replaced when changing the engine oil.

#### WARNING

- ***The engine oil is very hot while the engine is running or right after the engine is stopped. Be careful not to be burned.***
- ***Avoid oil contact while changing or adding engine oil and wear eye protection to prevent eye contact.***

### ⚠ WARNING

- *Prolonged and repeated contact with the engine oil may cause skin disorders and skin cancer. If skin contact is made, wash thoroughly with soap or hand cleaner as soon as possible.*
- *Keep the used oil out of reach of children.*
- *It is required to use CJ4 grade engine oil as this tractor is equipped with the NOx emission control system.*
- *Using low quality engine oil can damage the after treatment system.*

### ⚠ CAUTION

To avoid personal injury :

- Be sure to stop the engine before changing the oil or replacing the filter.
- Check the engine oil level before every operation of the tractor. If the engine oil is insufficient, the engine can be damaged, and this is not covered by warranty. Be sure to add the engine oil when its level is below the lower limit of the oil dipstick.
- Do not dispose of used oil and oil filter into drainage and other places not designated by regulations. Observe applicable regulations when disposing used oil and filters.

### ⊕ IMPORTANT

- Use only KIOTI genuine engine oil and filters to insure smooth operation and durability of the engine.

## REPLACING FUEL FILTER



(1) Drain Tap

1. Place a suitable container below the fuel filter assembly to retain spilled fuel oil.
2. Thoroughly clean the outside surfaces of the fuel filter assembly. Open the drain tap at the bottom of the filter casing to drain the fuel from the filter.
3. Use a strap wrench to loosen the filter casing. Remove the casing and element from the fuel filter head.

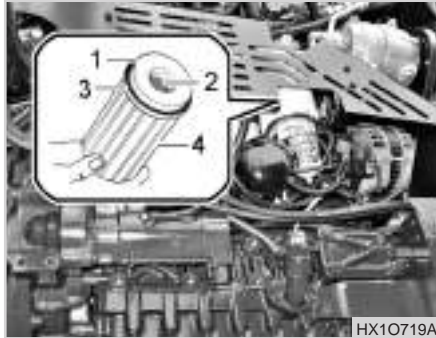

(1) Filter Element      (2) Thread  
(3) Seal                (4) Filter Casing

4. To remove the filter element from the casing; Press down on the filter element, against the spring pressure, and rotate the element to counterclockwise to release it from the filter casing.
5. Put the new filter element inside the casing and press the element down against the spring pressure. Rotate the element to clockwise to lock the element into the casing.
6. Fit a new seal to the casing and lightly lubricate the seal face with clean fuel oil.

7. Check that the thread on the inside of the element is not damaged.
8. Fit the filter assembly to the fuel filter head and tighten by hand until the filter assembly contacts the filter head. Tighten the assembly a further 1/8 of a turn by hand. Do not use a strap wrench.
9. Close the drain tap and remove the container.

 **CAUTION**

- **The pre-filter canister and main filter elements must be renewed at the same time.**
- **Do not allow dirt to enter the fuel system. Before a connection is disconnected, clean the area around the connection. After a component has been disconnected, fit a suitable cover to all open connections.**

## EVERY 800 HOURS REPLACING TRANSMISSION FLUID

1. See pages 7-35.



## EVERY 1,000 HOURS ADJUSTING ENGINE VALVE CLEARANCE

This service can be affected by the engine sensitively. Therefore, contact your local **KIOTI** Dealer for this service.

## EVERY 1 YEARS REPLACING AIR CLEANER PRIMARY ELEMENT



- (1) Element Assembly
- (2) Filter Assembly
- (3) Evacuator Valve

1. The air cleaner uses a dry element. Never apply oil.
2. Dust should not accumulate in the evacuator valve. Remove and clean it. Clean the element and filter assembly every week. If the tractor is operated in extremely dusty conditions, daily inspection is required.
3. Do not service the filter unless it should be cleaned.

4. If the element is stained with carbon, dust or oil, replace the filter.
5. For filter replacement, refer to the instruction for replacing the air cleaner filter for every year.

To clean the element, use only clean dry compressed air on the inside of the element. Air pressure at the nozzle must not exceed 29 psi (2 kgf/cm<sup>2</sup>). Maintain reasonable distance between the nozzle and the filter.

### **+** IMPORTANT

- **The air cleaner will only fulfill its function if it is correctly and regularly maintained. A poorly maintained air cleaner will mean loss of power, excessive fuel consumption and a reduction in engine life.**
- **Do not run the engine with filter element removed.**

**⊕ IMPORTANT**

- Be sure to refit the cap with the arrow ↑ (On the rear of cover) upright. If the cap is improperly fitted, evacuator valve will not function and dust will adhere to the element.
- Be sure to check any air leak or opening in the air intake system. Even the small gap or opening in the air intake system can cause the serious engine problem after a few years of operation.

**EVACUATOR VALVE**

Open the evacuator valve once a week under ordinary conditions or daily when used in dusty conditions to get rid of large particles of dust and dirt.

**REPLACING ENGINE OIL AND FILTER**

1. See pages 7-36.

**EVERY 2 YEARS  
FLUSH COOLING SYSTEM  
AND CHANGING COOLANT**

(1) Drain Cock

1. Stop the engine and let it cool.
2. To drain the coolant, open the radiator drain cock and remove radiator cap. The radiator cap must be removed to completely drain the coolant.
3. After all coolant is drained, close the drain cock.
4. Fill with clean water and cooling system cleaner.
5. Follow the cleaner manufacture's instruction.



(1) Reservoir Tank  
(A) Min (Lack)

6. Add water only up to the "MIN" mark or higher level of the reservoir tank.
7. Start and operate the engine for few minutes.
8. Stop the engine and let it cool.
9. Check coolant level of reservoir tank and radiator. Add coolant if necessary.

Coolant capacity [U.S.gal. (L)]	
HX9010/1001	4.6 (17.4)
HX1151/1201	4.7 (18.0)

**⚠ CAUTION**

To avoid accidents :

- Do not remove the radiator cap while the coolant is hot. You can get burnt by hot steam. Make sure to remove it after the coolant is cooled down enough.
- Even though the coolant is cooled down, turn the cap to its first stop and then wait until it is depressurized before removing the cap completely.

**⊕ IMPORTANT**

- Do not start engine without coolant.
- Use clean, fresh water and anti-freeze to fill the radiator and reservoir tank.
- When the anti-freeze is mixed with water, the anti-freeze mixing ratio must be no less than 50% mixture of water and anti-freeze.
- Securely tighten radiator cap.
- If the cap is loose or improperly fitted, water may leak out and the engine could overheat.
- If the radiator cap has to be removed, follow the caution above and securely retighten the cap.
- If the coolant leaks, contact your local KIOTI Dealer.



## ANTIFREEZE

This tractor is filled with 50% of ethylene glycol at factory.

If the antifreeze has been replaced by tap water later on, the coolant can be frozen, leading to damage to the cylinder and radiator when the ambient temperature is below 0°.

Therefore, make sure to change water into antifreeze before winter season comes.

When changing the antifreeze with one of another type, flush the cooling system several times and contact a professional for the mixture ratio.

Vol. % Antifreeze	Freezing Point		Boiling Point	
	°F	°C	°F	°C
40	-12	-24	222	106
50	-34	-37	226	108

\* At 760 mmHg pressure. (Atmospheric)

A higher boiling point is obtained by using a radiator pressure cap.

### NOTE

- The temperatures shown on the left are industry standards that necessitate a minimum glycol content in the concentrated anti-freeze.
- When the coolant level drops due to evaporation, add water only. In case of leakage, add anti-freeze and water in the specified mixing ratio.
- Antifreeze absorbs moisture. Keep unused antifreeze in a tightly sealed container.
- Do not use radiator cleaning agents when antifreeze has been added to the cooling water. (Antifreeze contains an anti-corrosive agent, which will react with the radiator cleaning agent forming sludge which will affect the engine parts)

## REPLACING RADIATOR HOSE AND CLAMP

1. See pages 7-31.

## REPLACING POWER STEERING LINE

1. See pages 7-33.

## REPLACING FUEL LINE

1. See pages 7-21.

## REPLACING INTAKE AIR LINE

1. See pages 7-32.



## SERVICE AS REQUIRED DRAINING WATER FROM CLUTCH HOUSING



(1) Plug

1. There is a plug under the clutch housing.
2. Drain the water completely and install the plug. Drain the water into a container and dispose of it in a proper manner for environment protection.

## REPLACING AIR FILTER



(1) Bolt

(2) Filter

1. After loosening bolts from the left and right side of the cabin roof and separate the filter.

### WARNING

- *Tractor with cabs have no protection against dangerous substances, but have a protection against dust (Category 2). If the tractor is used to spray phytosanitary products or chemicals generally thought of as hazardous to health, the operator must wear individual protections (mask) suitable to the harmfulness of the actual product used.*





## CHECK AND CLEAN CAB AIR INTAKE FILTER

Check and clean the intake air filter every 100 hours or more often if needed. Keep the air filter clean for efficient operation of the heating and cooling system. Replace with genuine parts if damaged or when the filter cannot be cleaned.

### WARNING

- ***Cab air filters remove dust in the air, but are not capable of removing chemicals used in spraying crops or in weed control. Many chemicals used for these purposes are toxic when improperly used, and can be hazardous to operators and others in the area.***
- ***Follow the instructions of manufacturers of both the equipment and the chemicals regarding prohibitions against inhalation of dust or spray, personal hygiene practices, and other precautions noted by the manufacturers.***

### IMPORTANT

- **Always wear protective clothing, e.g.: overalls, goggles, gloves and face mask when preparing equipment for chemical spraying operations and ALWAYS follow the chemical manufacturers instructions.**

The air intake filters should be checked weekly or daily if used in extreme conditions. The standard paper element has the following efficiency with a maximum differential pressure increase of 2 mbar. SAE gross gauze mesh 99.5%.

### NOTE

- This element gives no protection against chemical spray.

### CAUTION

- **The Manufacturer has no responsibility whatever, either direct or indirect, for application of special filters and/or changes to the air intake system of the cab.**
- **Every change to the cab intake system can result in a health hazard for the operator and significantly alter the performance of the air conditioning system. In any case, the cab is not guaranteed as perfectly dust-tight.**
- **Always wear individual protections when working in particularly dusty environment.**

### NOTE

- Replace filters with original spares only.

**⊕ IMPORTANT**

- **Dispose of filters correctly in accordance with local regulations. Be responsible for the environment.**

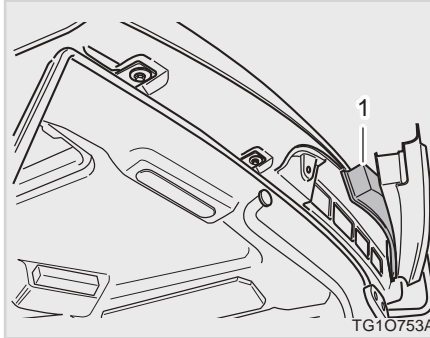

**⚠ WARNING**

- **Remember that the cab filter is not suitable for chemicals in general. Absolute protection against these products can therefore only be achieved by taking the precautionary measures required by the degree of harmfulness of the actual products used.**
- **This latter precaution must be strictly observed for filters of any type.**

**⚠ WARNING**

- **Take the filter off before washing the cab. If the cab is washed and the filter has not been demounted, take care to prevent the jet of water from splashing on to the protective grille. otherwise your cab's filter will be irreparably damaged.**

**⚠ CAUTION**

- **Only install carbon filters supplied sealed when delivered: comply with the operating instructions on the container and enclosed in the filter package.**
- **Carefully comply with the operating instructions on the filter packages or labels. Replace the filters at the intervals specified by the filter manufacturer.**
- **Contact your Dealer if specific filters against chemicals must be used.**

**⚠ WARNING**

- Always wear the right sort of personal protective equipment to protect against the harmful products used.

## CHECKING AND REPLACING WIPER INSPECTION

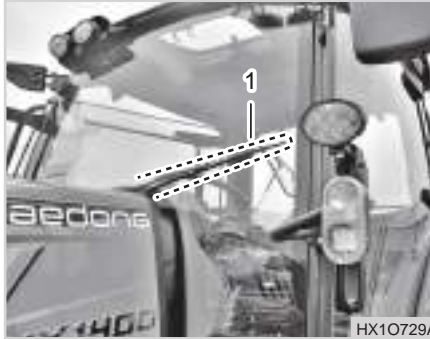

(1) Wiper

Check the operation and wear of the wiper blades frequently. To replace the wiper blade, press the wiper fixing lever to separate it and then pull it away.

To remove the wiper arm, lift the cap of the wiper arm, remove the nut, and set the wiper arm upright. Then, hold the arm head and shake it left and right to remove the wiper arm from the drive spindle. Disconnect the washer fluid hose and then install a new wiper arm to its position by aligning it to the proper angle.

## REPLACEMENT

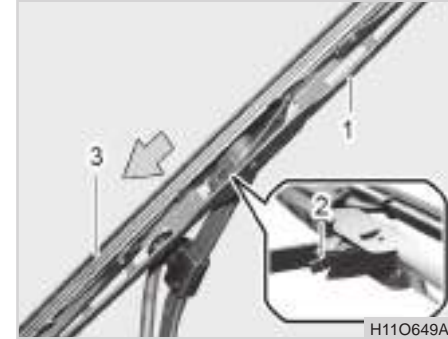
(1) Wiper Arm  
(3) Wiper Blade

(2) Wiper Fixing Lever

1. Set the wiper upright to replace the wiper blade.
2. Hold the blade with one hand and press the blade fixing lever with the other hand to separate the blade from the fixing part.



(1) Wiper Blade



(1) Wiper Arm (2) Fixing Lever

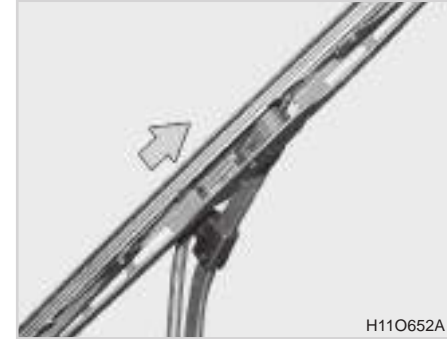

3. Lower the blade and pull out the blade by moving it in the shape of "U". (Arrow direction in the figure)

4. Set a new wiper blade horizontal so that the fixing lever is facing down. Align the wiper arm with the fixing lever slot and lower the blade.

5. Lift the wiper blade to its end and install it so that the fixing lever is engaged with the wiper arm. (A clicking sound is heard)

 **CAUTION**

- When the wiper blade is separated, the wiper arm should not contact the windshield or rear glass. The glass can be damaged.



## REPLACING FUSE

### CAUTION

- When wiping the windshield, set the wiper blade upright, spray water onto the glass with a hose, and wipe the glass with clean cloth.
- If the wiper blade is frozen to the glass in a cold weather or there is not washer fluid, never operate the wiper.
- In order to prevent damage of the wiper blade, never use synthetic detergent, thinner or solvent on the windshield.



(1) Fuse Box



(1) Fuse Storage Case      (2) Fuse

Fuses protect the tractor electrical system from potential damage. A blown fuse indicates that there is an overload or short somewhere in the electrical system.

The fuse panel is located inside the right step.

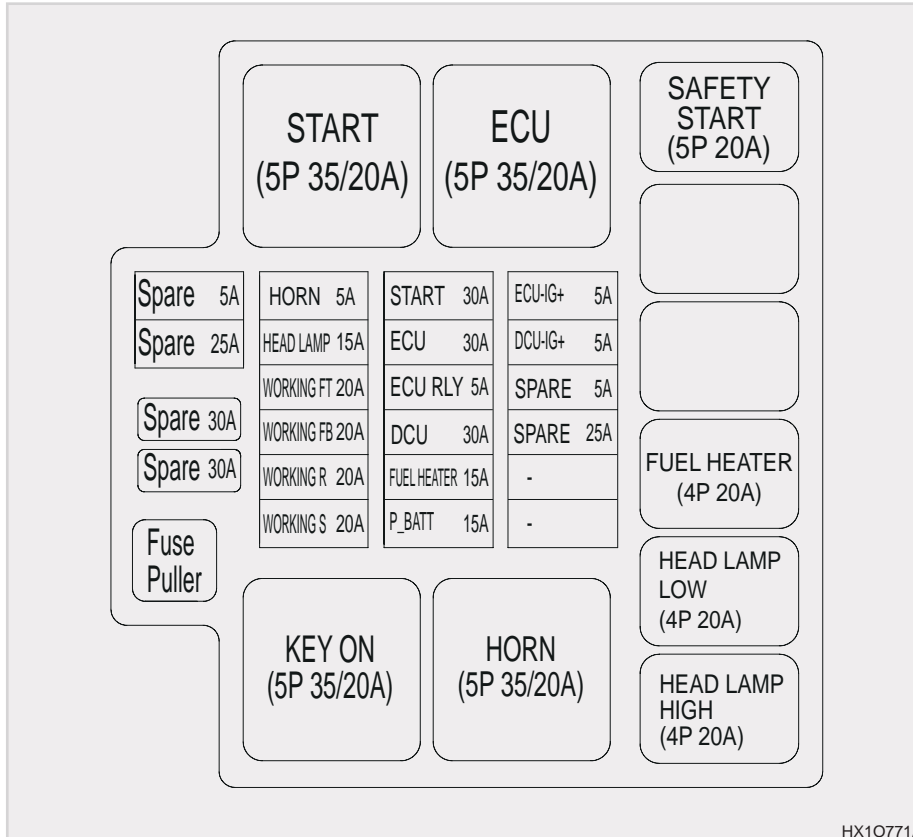

There are marks for the fuse capacity and location on the cover of the fuse panel. Replace the fuse according to the following procedure :

1. Turn the key switch to the "OFF" position and turn off all the electrical devices.
2. Open the fuse box cover and check the fuse in question using fuse tongs.

HX10771A

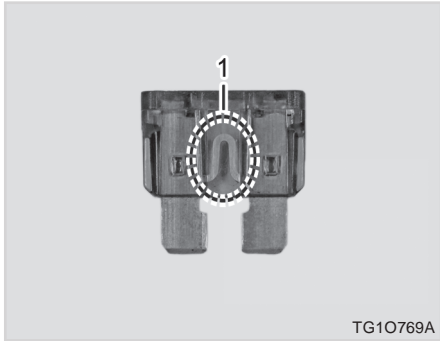

(1) Normal Fuse

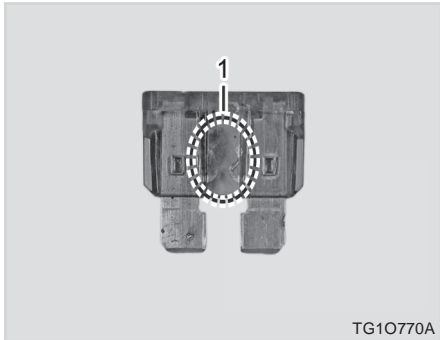
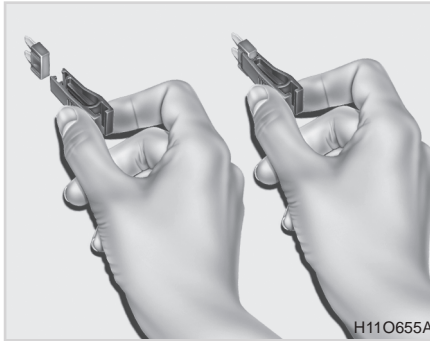

(1) Blown Fuse

3. If the fuse is blown, replace it with a new fuse with same capacity. Make sure it is firmly installed.
4. Install the fuse box cover.

**⚠ WARNING**

- **Never use a fuse with the capacity higher than specified on the fuse box cover.**
- **If using a faulty fuse, steel wire, or foil, the electrical device can be damaged or even catch a fire.**

**📖 NOTE**

- If the replaced fuse is blown soon, it is probable that the wiring system is faulty. In this case, contact your local **KIOTI Dealer**.
- If the fusible link, relay or other electrical component is faulty, contact your local **KIOTI Dealer**.

## REPLACING CABIN FUSE



(1) Fuse Box 1      (2) Fuse Box 2

The fuse box in the cabin is located behind the driver's seat and protects the electrical devices in the cabin except for the electrical devices of the main body. The replacement method is the same as the procedure for replacing the fuse of the main body electric device.

### [EU MODEL] FUSE BOX 1

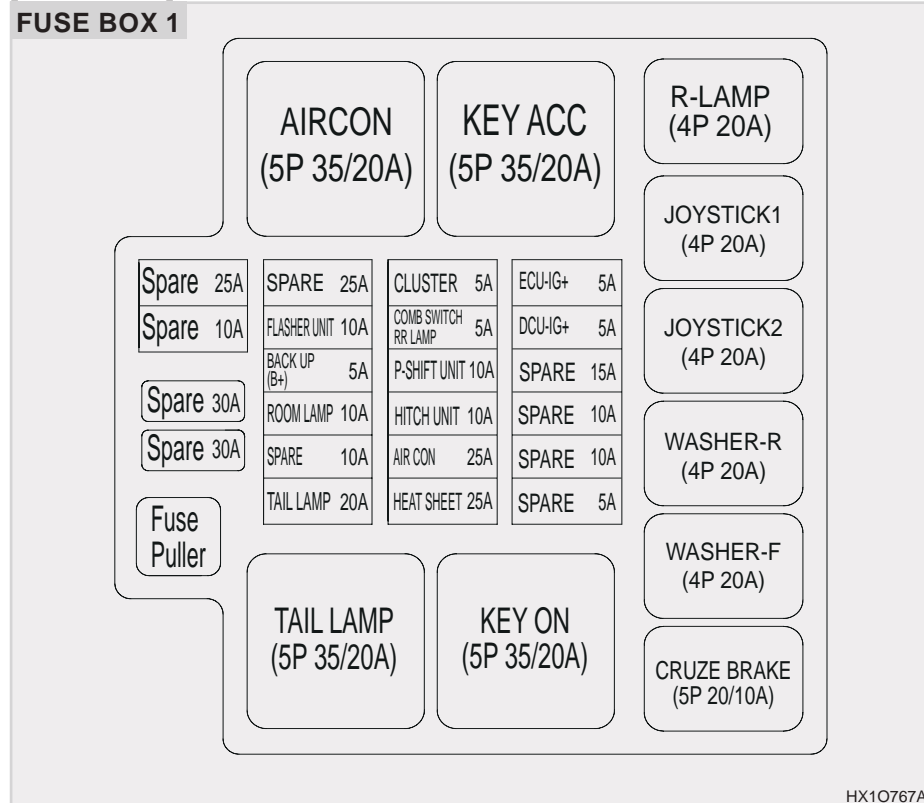





FUSE BOX 2

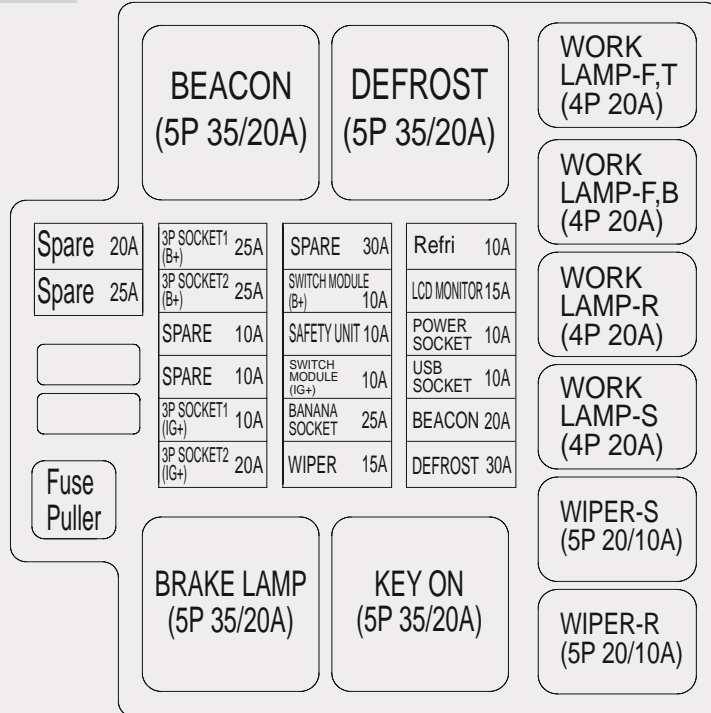

HX1O768A

**[US MODEL]**  
**FUSE BOX 1**

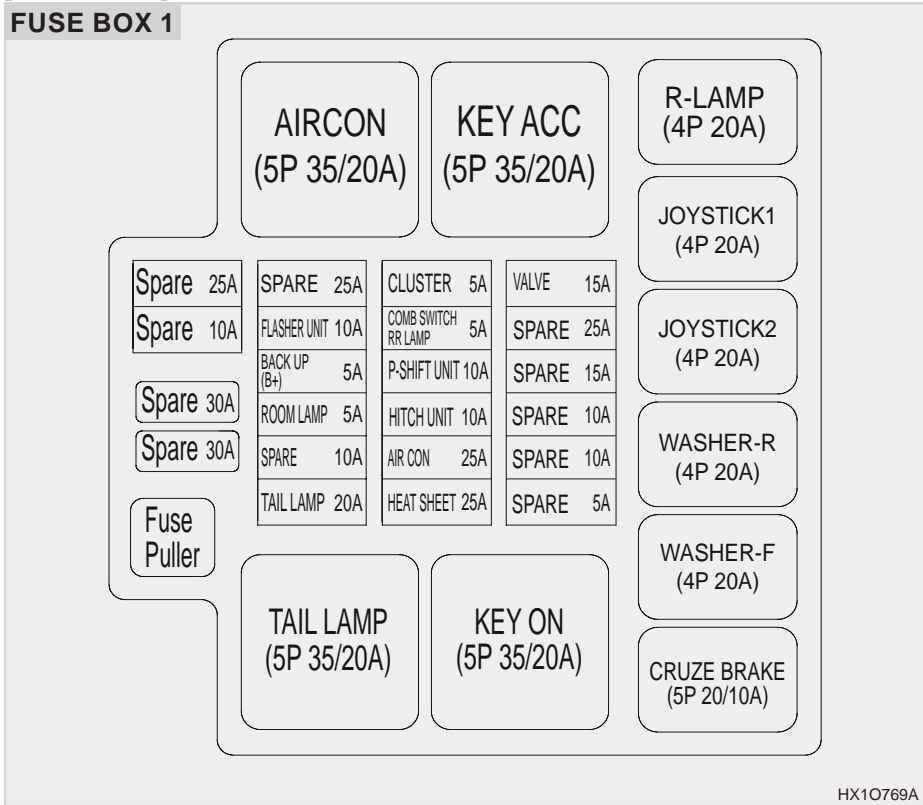



**FUSE BOX 2**

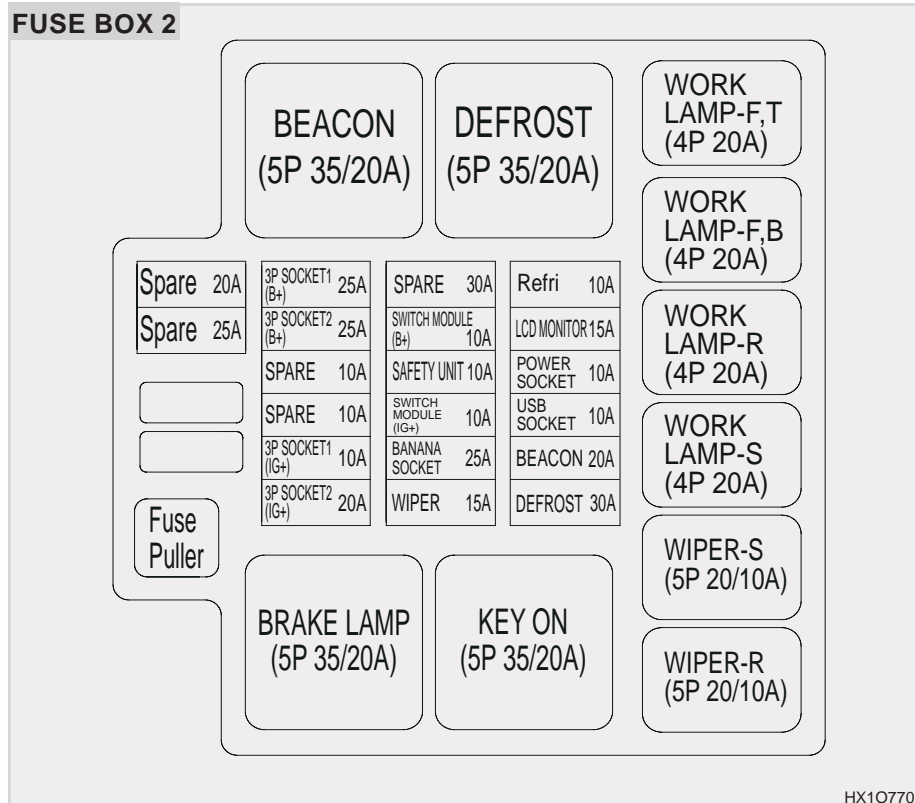

**SLOW BLOW FUSE**



(1) Slow Blow Fuse

The slow-blow fuse is to protect the electric wiring. If it is blown, find and repair the cause and replace it with a new genuine part.

**7**

<b>Slow Blow Fuse</b>
60, 140A

### ⊕ IMPORTANT

- Using a non-approved slow-blow fuse can damage electrical systems in the tractor severely.
- Refer to the chapter “Troubleshooting” in this manual or contact your local KIOTI Dealer for specific information dealing with electrical problems.

## REPLACING BULB

The bulb and capacity used in this tractor are listed in the below table. This section only describes procedures the users can handle.

No.	Bulb		Capacity
1	Headlamp		24W LED
2	Position lamp (Front)		5W
3	Turn signal lamp		21W
4	Work lamp		24W LED
5	Cluster	Charging warning light	3W
	Indicator	Others	1.4W
6	Backup lamp		21W

## HEADLAMP



(1) Handle  
(A) Pull

(B) Open

1. Turn the key switch to the "OFF" position and open the hood.

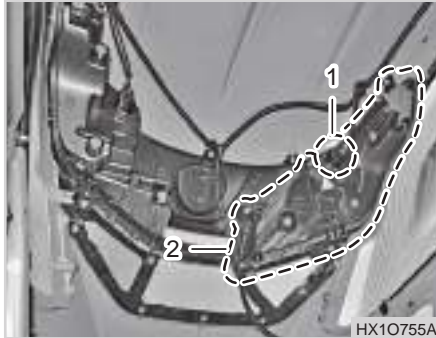

(1) Connector  
(2) LED Lamp Assembly

2. Disconnect the wire connector.
3. Undo the mounting nut to remove the LED lamp assembly.
4. Install the new LED lamp assembly and connect the connector.

### ⚠ WARNING

- ***If using a bulb other than the specified one, the lamp can be damaged and the tractor can even catch fire.***
- ***Make sure to use bulbs with the specified capacity.***

### ⚠ CAUTION

- **Make sure to use a Kioti genuine bulb. Using a non-recommended bulb can cause a fire.**
- **The headlamps can temporarily be fogged due to rain or car wash. This is because of the temperature difference between the inside and outside of the lamp, which is normal.**

### WORK LAMP (FRT/RR)

Different LED and halogen work lamps are mounted depending on the model.

The LED and halogen work lamps are designed to enhance the visibility during work. For the LED work lamps, when they need replacement, replace the whole assembly.

Do not touch the illuminating part of the halogen bulb.

The bulb life can be shortened by finger prints, dust and moisture, or the bulb even can be broken. Clean it with soft cloth.

Be careful of the following when replacing the halogen bulb :

- Replace the bulb after it is cooled down.
- Do not touch the glass of the bulb.
- Handle the bulb with care and be careful not to scratch or rub it.
- Do not let the bulb contact with liquid when it is illuminated.
- Wear protective glasses when replacing the bulb.

### REPLACE WORK LAMP (HALOGEN WORK LAMPS)

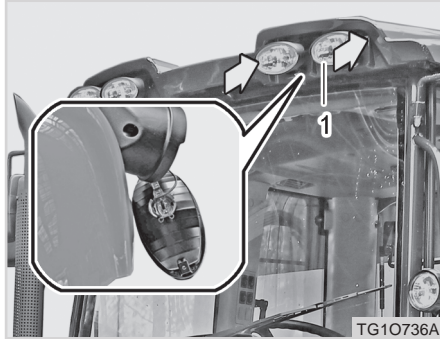

(1) Work Lamp Glass Case

1. Turn the key switch to the "OFF" position and unscrew the screw from the mounting hole with a cross-head screwdriver to separate the front glass case.

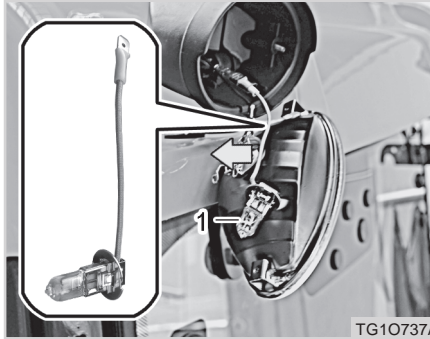

(1) Work Lamp Bulb

2. Unscrew the ground wire screw, disconnect the connector, and turn the bulb counterclockwise to remove it. Then, install a new bulb with the same capacity.

### REPLACING THE LED WORK LAMPS



(1) LED work lamp (2) Wiring  
(3) Work lamp mounting bracket



1. Turn the key switch "OFF," and remove the LED work lamp assembly from the work lamp mounting bracket.
2. Disconnect the connector and replace it with a new LED work lamp.

**ROOM LAMP***(1) Room Lamp*

1. Fit a flat-bladed screwdriver into the edge of the room lamp and pry off the room lamp cover.

*(1) Room Lamp Bulb*

2. Remove the room lamp bulb by pulling it up. Install a new bulb.

### TURN SIGNAL LAMP (FRONT)



- (1) Turn Signal Lamp (FRT)
- (2) Turn Signal Lamp (FRT) Bulb

1. Remove the cap and unscrew the mounting bolts to remove the front turn signal lamp assembly.
2. Turn the bulb body counterclockwise to remove it.
3. Remove the bulb by pressing it down lightly and install a new bulb. Fit the socket to the grooves and turn it clockwise.

### TURN SIGNAL LAMP (REAR)



- (1) Turn Signal Lamp (RR)

1. The turn signal lamp (rear) is installed on the rear fender.

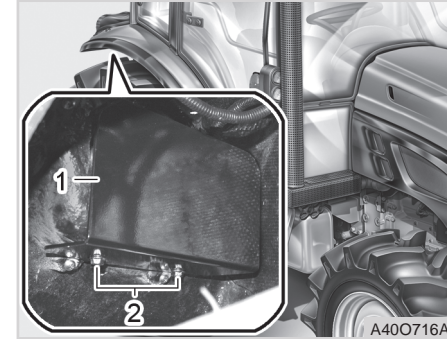

- (1) Protective Cover
- (2) Mounting Bolt

2. Unscrew the mounting bolts from the inside of the rear fender.



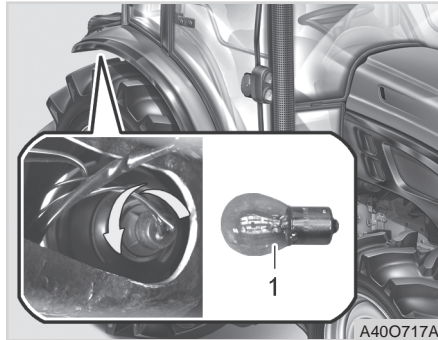

(1) Turn Signal Lamp (RR) Bulb

3. Remove the bulb by turning its socket counterclockwise. Install a new bulb.

## LICENSE PLATE LAMP

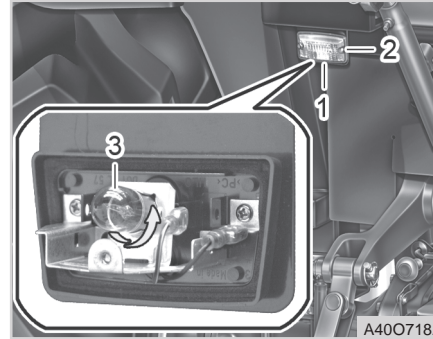

(1) License Plate Lamp  
(2) Mounting Bolt  
(3) License Plate Lamp Bulb

1. Remove the cover and unscrew the bolt. Then, turn the bulb while pressing it down lightly to remove it. Install a new bulb.

### CAUTION

- Do not touch the bulb if it is still illuminated or right after it is turned off. You can be burnt by the hot bulb.

### CAUTION

- For some bulbs which require delicate handling or work process, contact your local KIOTI Dealer.
- Do not touch the illuminating glass part of the halogen bulb. The bulb life can be shortened by finger prints, dust and moisture, or the bulb even can be broken. Clean it with soft cloth.
- The halogen bulb contains compressed gas, so it can explode if dropping or scratching it. Therefore, never use a bulb if it is scratched or was dropped.
- When separating the cover by prying it off with a screwdriver, be careful not to damage it.



 **CAUTION**

- **Before replacing a bulb, make sure to put the key switch and the switch for the corresponding bulb to the “OFF” position.**
- **Install a new bulb with the same capacity after removing the installed bulb.**

## CHECKING THE REFRIGERANT

Insufficient refrigerant degrades the A/C performance. As excessive amount of refrigerant also damages the A/C system, if any defect is identified, have it checked at a local KIOTI service center immediately.

 **CAUTION**

- **Park the tractor on even ground and choke the wheels.**
- **Put the shuttle shift lever, main shift lever, and PTO lever in the neutral position.**

 **WARNING**

- ***As the refrigerant is at high pressure, make sure to have only a certified specialist repair the A/C. An injury can occur.***

1. Operate the A/C as follows:

- Engine rpm: Approx. 1,500 rpm
- Temperature control switch: At the point of maximum cooling temperature
- Blower speed control dial: Level 4
- A/C switch: ON



## STORAGE AND DISPOSAL

<b>TRACTOR STORAGE .....</b>	<b>8-2</b>
DAILY STORAGE .....	8-2
LONG-TERM STORAGE .....	8-2
<b>USING TRACTOR AFTER STORAGE .....</b>	<b>8-3</b>
<b>USAGE AND DISPOSAL.....</b>	<b>8-4</b>

8

8



## TRACTOR STORAGE DAILY STORAGE

1. Keep the tractor clean when it is stored. Make sure to wash it after work.
2. Store it indoors if possible. If it should be kept outside, cover it.

### WARNING

- *When operating the tractor in an enclosed area, ventilate the area to release exhaust gas to the outside. The exhaust gas is colorless and not visible, but is harmful.*

3. Remove the battery from the tractor in winter and store it indoors.
4. Add anti-freeze to the tractor in winter season in order to prevent the radiator from freezing.
5. Remove the ignition key and store it separately.

## LONG-TERM STORAGE

Follow the instructions below if the tractor is not to be used for a long period of time. This is to operate the tractor again with minimum preparation after long-term storage. Repeat this procedure if the tractor hasn't been used for one year.

### IMPORTANT

- **If the tractor is not used for an extended period of time, follow the instructions below to prevent corrosion and performance deterioration of the tractor while it is stored.**

1. Check the bolts and nuts for looseness, and tighten if necessary.
2. Apply grease to tractor areas where bare metal will rust also to pivot areas.
3. Detach the weights from the tractor body.
4. Inflate the tires to a pressure a little higher than usual.

5. Change the engine oil and run the engine to circulate oil throughout the engine parts all for about 5 minutes.
6. With all implements lowered to the ground, coat any exposed area such as hydraulic cylinder piston rods with grease.
7. Remove the battery from the tractor. Store the battery following the battery storage procedures.
8. Keep the tractor in a dry place where the tractor is sheltered from rain. Cover the tractor.
9. Clean the engine components as well as the tractor.
10. Add grease to all the grease fitting.
11. Flush the cooling system and drain water from it. Also, add antifreeze as well as water.
12. Chock the frame in order to remove the weight from the tires.
13. Set all control systems neutral.
14. Plug any open exhaust pipes.

15. Attach a tag onto the tractor to inform the storage condition of the tractor.
16. Interlock the brake pedals and apply the parking brake.

**CAUTION****To avoid injury :**

- **Never clean the tractor body while the engine is running.**
- **Never run the engine in an enclosed area without proper ventilation system in order to prevent poisoning by exhaust gas.**
- **When storing the tractor, remove the key from the switch and store it separately in order to prevent an unauthorized person from operating the tractor and being injured.**
- **Cover the tractor after the muffler and the engine have cooled down.**
- **If the battery is not to be removed, disconnect its negative terminal at least. The wiring can be gnawed by rodents, leading to a fire.**

**USING TRACTOR AFTER STORAGE**

1. Check the tire air pressure and inflate the tires if they are low.
2. Install a fully charged battery.
3. Check the fan belt tension.
4. Check all fluid levels. (Engine oil, transmission/hydraulic oil, engine coolant and any attached implements)
5. Check the urea level in the tank and add urea as necessary.
6. Remove grease from the exposed cylinder rod.
7. Apply grease to the lubrication points.
8. Remove the cover from the exhaust pipe.
9. Get onto the tractor and start the engine.
10. Check if the instrument panel and all parts operate correctly while running the engine for a few minutes.



## USAGE AND DISPOSAL

11. Drive the tractor outside and check if it is operating properly. Park the tractor outside and idle engine for at least 5 minutes. Stop the engine and visually inspect the tractor. Check if there is leakage.
12. Start the engine, release the parking brake, and check the brake condition while driving forward. Adjust the brake pedals if necessary.
13. Stop the engine and check for leakage. Repair any part as required.

In order to protect the environment, use and dispose of the tractor keeping the following in mind :

1. When changing the oil or coolant by yourself, be careful not to spill it and dispose used oil and coolant properly according to the applicable regulations.
2. Never leave or discard the expired tractor or implement, but contact your local **KIOTI** Dealer to dispose it according to the regulations.
3. Avoid working under high load as it can cause excessive exhaust gas, which is harmful to the environment.



# *TROUBLESHOOTING*

**ENGINE TROUBLESHOOTING ..... 9-2**  
**TRACTOR TROUBLESHOOTING..... 9-4**

# 9

9



This troubleshooting chart summarizes simple service items for users who are familiar with mechanical systems. For more detailed service items, contact your local **KIOTI** Dealer.

## ENGINE TROUBLESHOOTING

CAUSE	COUNTERMEASURES
<p>1. When engine is difficult to start</p>	<ul style="list-style-type: none"> <li>Fuel is thick and doesn't flow.</li> </ul>
	<ul style="list-style-type: none"> <li>Air or water mixed in fuel system.</li> </ul>
	<ul style="list-style-type: none"> <li>Thick carbon deposits on orifice of injection nozzle.</li> </ul>
	<ul style="list-style-type: none"> <li>Valve clearance is wrong</li> </ul>
	<ul style="list-style-type: none"> <li>Engine oil become thick in cold weather and engine cranks slow.</li> </ul>
<ul style="list-style-type: none"> <li>Check the fuel tank and fuel filter.</li> </ul>	<ul style="list-style-type: none"> <li>Remove water, dirt and other impurities.</li> </ul>
<ul style="list-style-type: none"> <li>As all fuel will be filtered by the filter, if there should be water of other foreign matters on the filter, replace the filter.</li> </ul>	<ul style="list-style-type: none"> <li>If air is in the fuel filter or injection lines, the fuel pump will not work properly.</li> </ul>
<ul style="list-style-type: none"> <li>To attain proper fuel injection pressure, check carefully for loosened fuel cap nut, etc.</li> </ul>	<ul style="list-style-type: none"> <li>Loosen air vent screw over fuel filter and fuel injection pump to eliminate all the air in the fuel system.</li> </ul>
<ul style="list-style-type: none"> <li>This is caused when water or dirt is mixed in the fuel. Clean the nozzle injection piece, being careful not to damage the orifice.</li> </ul>	<ul style="list-style-type: none"> <li>Check to see if nozzle is working properly or not, if not, install a new nozzle.</li> </ul>
<ul style="list-style-type: none"> <li>Adjust valve clearance. (When the engine is cold)</li> </ul>	<ul style="list-style-type: none"> <li>- Inlet : 0.25 mm (0.010 in.)</li> <li>- Exhaust : 0.30 mm (0.012 in.)</li> </ul>
<ul style="list-style-type: none"> <li>Change grade of oil according to the weather. (Temperature)</li> </ul>	





CAUSE		COUNTERMEASURES						
1. When engine is difficult to start	• Start motor does not rotate when key switch is turned	• Depress the clutch pedal unless depressed. (Manual type)						
		• Put the PTO switch to the OFF position.						
		• If the switch or start motor is faulty, have it repaired in a workshop.						
		• If any terminal is loose or corroded, clean or fix it firmly.						
2. When output is insufficient	• Valve out of adjustment	• Adjust to proper valve clearance. - Inlet : 0.25 mm (0.010 in.) - Exhaust : 0.30 mm (0.012 in.)						
	• Air cleaner is dirty	• Clean the element at every 100 hours of operation. • Replace the element at every 1 year of operation.						
	• Fuel injection pressure is wrong	• Adjust it to 184 Kg/cm <sup>2</sup> or replace the injection nozzle.						
3. When color of exhaust is specially bad	• Fuel is of extremely poor quality	• Select good quality fuel. <table border="0" style="margin-left: 20px;"> <tr> <td style="padding-right: 20px;">Temperature</td> <td>Fuel type</td> </tr> <tr> <td>- Above -10°C (14°F)</td> <td>NO.2 Diesel</td> </tr> <tr> <td>- Below -10°C (14°F)</td> <td>NO.1 Diesel</td> </tr> </table>	Temperature	Fuel type	- Above -10°C (14°F)	NO.2 Diesel	- Below -10°C (14°F)	NO.1 Diesel
	Temperature	Fuel type						
- Above -10°C (14°F)	NO.2 Diesel							
- Below -10°C (14°F)	NO.1 Diesel							
• Nozzle is bad	• If necessary, replace with new nozzle.							

※ If you do not find the cause of trouble, consult your dealer for assistance.



## TRACTOR TROUBLESHOOTING

CAUSE		COUNTERMEASURES
1. When tractor does not move while engine is running	• Shift lever is in neutral position	• Check the shift levers.
	• Parking brake is applied	• Release the parking brake.
2. Clutch is not operating properly	• Clutch slips (Idles)	• Contact <b>KIOTI</b> dealer.
	• Clutch cannot be disengaged	
3. Brake is not operating properly	• Brake does not operate or only one brake pedal operates	• The brake pedal play is excessive. Adjust the play.
	• Brake pedal does not return properly	• The brake lining is worn or stuck. Have it replaced in a workshop.
4. Steering wheel is not operating properly	• Steering wheel is heavy or vibrate	• The brake return spring is damaged. Replace it.
		• Grease is insufficient on each mating surface. Remove rust and apply grease.
		• The toe-in is incorrect. Adjust it again.
	• Steering wheel play is excessive	• The tire inflation pressure is different. Inflate the left and right tires into the specified pressure.
5. Hydraulic system is faulty	• Oil is leaked from pipe or hose	• Each connection is loose. Re-tighten each connection and replace the part.
		• The steering wheel shaft is worn. Have it repaired in a workshop. Metal parts are worn. Have them repaired in a workshop. Each connection has play. Tighten the connection again.
	• 3-point hitch cannot be lowered	• The pipe clamp is loose. Re-tighten it.
		• The pipe is cracked. Have it repaired in a workshop.
		• Set the lowering speed control knob to open if it is set to the stop position.
		• The valve and cylinder are damaged. Have them repaired in a workshop.



CAUSE		COUNTERMEASURES
5. Hydraulic system is faulty	• 3-point hitch cannot be lifted	<ul style="list-style-type: none"> <li>• The transmission fluid is insufficient. Add it to the specified level.</li> <li>• There is air in the intake pipe. Bleed the pipe.</li> <li>• The oil filter is clogged. Replace it.</li> <li>• The hydraulic filter, valve and cylinder are malfunctioning. Have them repaired in a workshop.</li> </ul>
	• 3-point hitch vibrates by itself	<ul style="list-style-type: none"> <li>• Set the draft control lever to the "Deep" position.</li> <li>• Select the highest top link hole.</li> </ul>
6. Electric system is faulty	• Headlamps cannot be turned on or are dim.	• The fuse is blown. Check the wiring and replace the fuse.
		• The bulb is blown. Replace it
		• The ground and terminal wirings are poorly contacted. Check and clean them.
		• The battery electrolyte level is low. Charge the battery.
	• Battery cannot be charged	• Check the battery and alternator.
• Horn does not sound	<ul style="list-style-type: none"> <li>• The horn switch is faulty. Replace or see <b>KIOTI</b> dealer.</li> <li>• The wiring is faulty. Replace or See <b>KIOTI</b> dealer.</li> <li>• The horn is damaged. Repair or replace it.</li> </ul>	
• Turn signal lamps do not blink	<ul style="list-style-type: none"> <li>• The bulb is blown. Replace it.</li> <li>• The blinking device is faulty. Repair or replace it.</li> <li>• The ground and terminal wirings are poorly contacted. Check and clean them.</li> </ul>	



CAUSE		COUNTERMEASURES
6. Electric system is faulty	• Work lamps do not come on	• The bulb is blown. Replace it.
		• The ground and terminal wirings are poorly contacted. Check and clean them.
7. Heater/air conditioner motor is faulty	• Fan speed is slow or no air is blown out	• The fan speed control switch and motor are faulty. Repair or replace them.
		• The air suction filter is clogged.
		• The wiring is short circuited. Check and repair it.
8. A/C performance is poor	• Abnormal noise occurs	• The internal parts are not sufficiently lubricated. Add lubricant.
		• The belt is loose. Adjust the belt tension.
		• The bracket is loose. Tighten its bolts again.
		• Inner and outer components are damaged. Check and repair them
	• Refrigerant and oil are leaking	• The sealing washer is broken. Replace it.
		• The tightening bolt is loose. Tighten it
	• High temperature and low pressure occur	• The refrigerant is insufficient. See <b>KIOTI</b> dealer.
		• The compressor is faulty. Repair or replace it.
	• Compressor clutch does not operate	• The wiring is faulty. Check and replace it.
		• The voltage is low. Replace the battery.
• The internal part is malfunctioning. Replace it.		

※ If you do not find the cause of trouble, consult your dealer for assistance.



*INDEX*

**INDEX..... 10-2**

**10**

**10**

**NUMERIC**

3-PIN POWER SOCKETS & BANANA JACKS.....4-60  
 3-POINT HITCH CONTROL SYSTEM .....5-19  
 4WD LAMP .....4-19  
 7-PIN POWER OUTPUT SOCKET.....4-67

**A**

A/C REFRIGERANT INSPECTION.....4-67  
 ACCESSORY .....4-59  
 ADDITIONAL FRONT WEIGHT.....4-74  
 ADDITIONAL LIQUID TYPE WEIGHT .....4-77  
 ADDITIONAL REAR WEIGHT(IF EQUIPPED).....4-76  
 ADDITIONAL WEIGHT(IF EQUIPPED) .....4-74  
 ADJUSTING AIR CONDITIONER BELT TENSION .....7-30  
 ADJUSTING ARMREST ANGLE .....4-50  
 ADJUSTING BRAKE PEDAL.....7-30  
 ADJUSTING FAN BELT TENSION.....7-20  
 ADJUSTING FAN BELT TENSION.....7-31  
 ADJUSTING PROCEDURE .....7-33  
 ADJUSTING THE HEADREST HEIGHT.....4-50  
 ADJUSTING THE IMPLEMENT OPERATION CON-  
 TROLLER HEIGHT .....4-45  
 ADJUSTING THE LUMBAR SUPPORT.....4-50  
 ADJUSTING TOE-IN .....7-33

ADJUSTMENT OF STABILIZER .....6-10  
 ADJUSTMENT OF TOP LINK.....6-8  
 AIR CONDITIONER MAINTENANCE .....4-66  
 AIR CONDITIONER SWITCH.....4-64  
 ALLOWABLE TOLERANCE OF FREE PLAY BE-  
 TWEEN LH AND RH BRAKE PEDALS.....7-20  
 ANTENNA.....4-58  
 ANTIFREEZE .....7-43  
 AUTO DRAFT LAMP .....4-20

**B**

BATTERY .....7-27  
 BATTERY CHARGING LAMP.....4-17  
 BATTERY SWITCH .....7-28  
 BEACON LIGHT BUTTON (IF EQUIPPED) .....4-42  
 BELTS AND RUBBER PARTS.....2-5  
 BLEEDING BRAKE FLUID LINE .....7-22  
 BRAKE PEDAL .....4-34  
 BRAKE PEDAL FREE PLAY .....7-30  
 BRAKE(ONE SIDE) LAMP .....4-21

**C**

CABIN SYSTEM .....4-54  
 CALIBRATION BUTTON.....4-42



CAUTIONS FOR DECAL MAINTENANCE .....	1-34	CHECKING TRANSMISSION FLUID LEVEL .....	7-14
CHANGING ENGINE OIL AND REPLACING FILTER...7-36		CHECKING WARNING LAMPS.....	5-6
CHANGING FRONT AXLE CASE OIL .....	7-34	CHECKING WHEEL BOLT / NUT TORQUE .....	7-25
CHARGING .....	7-29	CHEKING ENGINE OIL FILTER .....	7-31
CHECK AND CLEAN CAB AIR INTAKE FILTER.....	7-45	CLEANING AIR CONDITIONER CONDENSER .....	7-19
CHECK ITEM .....	5-2	CLEANING AND REPLACING AIR CLEANER FILTER	7-25
CHECKING AIR CONDITIONER HOSE .....	7-26	CLEANING GRILL, RADIATOR SCREEN .....	7-18
CHECKING AND ADDING FUEL.....	7-13	CLEANING THE TRACTOR .....	1-26
CHECKING AND ADDING UREA.....	7-15	CLUTCH PEDAL.....	4-34
CHECKING AND REPLACING WIPER .....	7-47	COMBINATION SWITCH .....	4-7
CHECKING AND REPLENISHING UREA TANK .....	7-23	COMPONENTS FOR ADDITIONAL FRONT WEIGHT ..	4-75
CHECKING BRAKE AND CLUTCH PEDALS.....	7-19	CONNECTING AND DISCONNECTING IMPLEMENT	5-22
CHECKING BRAKE OIL .....	7-21	CONNECTION .....	5-22
CHECKING BRAKE PEDALS.....	7-21	CRUISE PTO LAMP .....	4-21
CHECKING CAB CUSHION RUBBER.....	7-26	CUP HOLDER AND STORAGE.....	4-61
CHECKING COOLANT LEVEL.....	7-17		
CHECKING ENGINE OIL LEVEL .....	7-16	<b>D</b>	
CHECKING FUEL LINES .....	7-27	DAILY CHECK.....	7-12
CHECKING GAUGES, METER AND EASY CHECKER	7-19	DAILY CHECK ITEM.....	7-4
CHECKING HEAD LIGHT, HAZARD LIGHT ETC.....	7-19	DAILY STORAGE .....	8-2
CHECKING INTAKE AIR LINE .....	7-32	DECAL MOUNTING LOCATION .....	1-27
CHECKING RADIATOR HOSE AND CLAMP .....	7-31	DECALS .....	1-29
CHECKING SEAT BELT AND CABIN .....	7-19	DEFROST BUTTON .....	4-43
CHECKING THE REFRIGERANT .....	7-62	DESCRIPTION OF OPERATING SYSTEM.....	4-1



**D**

DIFFERENTIAL LOCK PEDAL (REAR) .....4-48  
 DIRECTION FOR STORAGE .....7-29  
 DISCONNECTION.....5-22  
 DOUBLE ACTING LEVER .....4-53  
 DOUBLE ACTING VALVE .....5-20  
 DPF REGENERATION SWITCH.....4-11  
 DPF REGENERATION UNDERWAY LAMP .....4-22  
 DPF REGENERATION WARNING LAMP.....4-22  
 DPF REGENERATION WARNING LAMP.....4-23  
 DRAFT CONTROL DIAL .....4-47  
 DRAFT HITCH AND TRAILER.....6-10  
 DRAINING WATER FROM CLUTCH HOUSING.....7-44  
 DRIVER'S SEAT'S STORAGE BOX .....4-51  
 DRIVING ON SLOPE .....5-15  
 DRIVING ON SLOPE .....6-16  
 DRIVING SELECTION SWITCH .....4-40

**E**

ECO/MODE SELECTION SWITCH.....4-13  
 EMERGENCY HAMMER (ONLY EU MODEL) .....4-62  
 EMISSION WARNING LAMP.....4-26  
 ENGINE CHECK WARNING LAMP .....4-24  
 ENGINE COOLANT TEMPERATURE GAUGE .....4-16

ENGINE OIL PRESSURE WARNING LAMP.....4-17  
 ENGINE SERIAL NUMBER .....2-2  
 ENGINE TROUBLESHOOTING .....9-2  
 ENTRANCE .....4-55  
 ERROR INDICATOR .....4-26  
 ESSENTIAL REPLACEMENT PART.....2-4  
 EVERY 1 YEARS .....7-40  
 EVERY 1,000 HOURS .....7-40  
 EVERY 100 HOURS .....7-25  
 EVERY 2 YEARS .....7-41  
 EVERY 200 HOURS .....7-31  
 EVERY 400 HOURS .....7-34  
 EVERY 50 HOURS .....7-24  
 EVERY 500 HOURS .....7-36  
 EVERY 800 HOURS .....7-39  
 EXTERIOR DEVICES .....4-55  
 EXTERIOR VIEW .....4-4  
 EXTERNAL DIMENSIONS.....3-2

**F**

FAN SPEED CONTROL DIAL.....4-63  
 FILTERS .....2-4  
 FLUSH COOLING SYSTEM AND CHANGING COOL-  
 ANT.....7-41





FOOT THROTTLE .....	4-37
FRONT WHEEL INSTALLATION PATTERN.....	4-73
FUEL GAUGE .....	4-15

**G**

GENERAL PRECAUTIONS .....	1-2
GENERAL SPECIFICATIONS .....	3-2
GENERAL SPECIFICATIONS .....	3-3
GENERAL TIRE INFORMATION.....	4-68
GLOW PLUG LAMP .....	4-18

**H**

HAND CLUTCH .....	4-30
HAND THROTTLE LEVER .....	4-37
HANDLING LOADER .....	6-15
HAZARD LAMP SWITCH.....	4-9
HEAD LIGHT HIGH BEAM LAMP .....	4-18
HEAD LIGHT SWITCH.....	4-7
HEADLAMP.....	7-56
HEATER AND AIR CONDITIONER .....	4-63
HIGH / LOW BUTTON (POWER SHUTTLE) .....	4-30
HIGH / LOW SELECTION SWITCH .....	4-45
HIGH / LOW SELECTION SWITCH .....	4-53
HORN SWITCH .....	4-9

HORN SWITCH .....	4-52
HOW TO DRIVE.....	5-10
HOW TO OPEN THE HOOD.....	7-12
HOW TO WARM UP ENGINE.....	5-8
HYDRAULIC BRAKE VALVE (IF EQUIPPED).....	6-13

**I**

IDENTIFICATION & INTRODUCTION OF WARRANTY ..	2-1
IMPLEMENT ADJUSTMENT CONTROLLER .....	4-44
IMPLEMENT ADJUSTMENT SWITCH .....	4-45
IMPLEMENT LIMITATIONS .....	3-10
IMPLEMENTS AND ATTACHMENTS .....	1-23
INDEX.....	10-1
INFLATION PRESSURE .....	4-69
INSIDE REAR VIEW MIRROR .....	4-59
INSPECTION .....	7-47
INSTALLING PTO SHAFT .....	6-12
INSTRUMENT PANEL.....	4-14
INTERIOR DEVICES.....	4-54

**J**

JOYSTICK LEVER .....	6-17
JOYSTICK LEVER .....	4-51
JUMP STARTING .....	5-9



**K**

KEY SWITCH .....4-6

**L**

LICENSE PLATE LAMP .....7-61  
 LOADING INTO AND UNLOADING OUT OF THE TRUCK .....5-17  
 LONG-TERM STORAGE.....8-2  
 LOW FUEL LEVEL WARNING LAMP .....4-25  
 LOW UREA LEVEL WARNING LAMP.....4-24  
 LOWERING SPEED SET DIAL .....4-46  
 LUBRICANTS .....7-10  
 LUBRICATING GREASE LOCATIONS.....7-24

**M**

MAIN SHIFT LEVER.....4-30  
 MAINTENANCE .....7-1  
 MAINTENANCE CHECK LIST.....7-4  
 MAINTENANCE SCHEDULE CHART .....7-5  
 MAINTENANCE SCHEDULE CHART BY OPERATING HOURS.....7-8  
 MASS(ES) AND TIRE(S) .....4-78  
 MOUNTING LOCATION.....4-5

**N**

NOISE LEVELS AS PERCEIVED BY THE OPERATOR .3-6

**O**

OILS AND FLUIDS .....2-4  
 OPERATING THE CONTROLS .....4-28  
 OPERATING THE ENGINE .....5-3  
 OPERATING THE TRACTOR.....5-10  
 OPERATION .....5-1  
 OPERATION FOR 3-POINT HITCH IMPLEMENTS .....6-8  
 OPERATION/DRIVING RESPONSE SETTING BUTTON4-42  
 OTHER COMPONENTS .....2-5

**P**

PARKING.....5-14  
 PARKING BRAKE LAMP.....4-19  
 PARKING BRAKE LEVER .....4-36  
 PARKING LOCK LEVER .....4-36  
 POSITION CONTROL LEVER.....5-19  
 POWER BOOST FUNCTION.....4-11  
 POWER SOCKET AND USB CHARGING PORT .....4-59  
 POWER STEERING LINE .....7-33  
 PRECAUTION AT OVERHEATING .....7-32

**PRECAUTION FOR INSTALLING HOW TO USE TOP**

LINK HOLES.....	6-9
PRECAUTIONS BEFORE OPERATION.....	1-2
PRECAUTIONS DURING OPERATION .....	1-9
PRECAUTIONS FOR HANDLING.....	7-27
PRECAUTIONS WHEN USING POWER STEERING .....	5-17
PRECAUTIONS WHILE DRIVING ON THE ROAD .....	5-16
PRE-OPERATION CHECK .....	5-2
PT1/2 COUPLER SOCKET (IMPLEMENT) .....	5-22
PTO & PTO SHIELD GUARD .....	6-12
PTO AUTO/MANUAL SWITCH .....	4-39
PTO CRUISE ACTIVATION .....	4-10
PTO CRUISE DEACTIVATION .....	4-10
PTO CRUISE ON/OFF SWITCH .....	4-10
PTO DISENGAGEMENT POSITION DIAL .....	4-47
PTO LAMP.....	4-19
PTO MAIN SWITCH .....	4-38
PTO RESTART/SETTING SWITCH .....	4-10
PTO SELECTION LEVER.....	4-33
PTO SHIFT LEVER .....	4-32
PTO SPEED MARK.....	4-15

**Q**

QUICK-TURN LAMP.....	4-20
----------------------	------

**R**

RANGE GEAR SHIFT LEVER .....	4-31
READJUSTMENT .....	7-34
REAR WHEEL INSTALLATION PATTERN .....	4-74
REAR WINDOW .....	4-56
REFRIGERATOR / HEATING CABINET.....	4-61
REMOTE HYDRAULIC .....	5-20
REMOTE PTO FUNCTION .....	4-39
REMOTE PTO SWITCH.....	4-47
REMOVAL AND INSTALLATION OF 3-POINT HITCH IMPLEMENT (WITH PTO SHAFT).....	6-2
REMOVING WATER FROM THE FUEL FILTER.....	7-23
REPLACE WORK LAMP (HALOGEN WORK LAMPS) .	7-58
REPLACEMENT .....	7-47
REPLACING AIR FILTER.....	7-44
REPLACING AIR CLEANER PRIMARY ELEMENT.....	7-40
REPLACING BULB.....	7-56
REPLACING CABIN FUSE .....	7-52
REPLACING ENGINE OIL AND FILTER .....	7-41
REPLACING FUEL FILTER .....	7-38
REPLACING FUEL LINE.....	7-43
REPLACING FUSE .....	7-49
REPLACING INTAKE AIR LINE .....	7-43
REPLACING POWER STEERING LINE .....	7-43



**R**

REPLACING RADIATOR HOSE AND CLAMP.....7-43  
 REPLACING THE LED WORK LAMPS .....7-58  
 REPLACING TRANSMISSION FLUID.....7-39  
 REPLACING TRANSMISSION FLUID AND FILTER .....7-35  
 RISK OF OVERTURNING .....1-6  
 ROOM LAMP.....7-59  
 ROOM LAMP.....4-59

**S**

SAFETY DECAL MAINTENANCE.....1-27  
 SAFETY PRECAUTIONS .....1-1  
 SAFETY PRECAUTIONS DURING SERVICING.....1-17  
 SAFETY PRECAUTIONS WHEN USING THE LOADER1-20  
 SEAT ADJUSTMENT.....4-48  
 SEAT SLIDING .....4-48  
 SEATBACK RECLINING.....4-49  
 SENSITIVITY CONTROL DIAL .....4-46  
 SERVICE AS REQUIRED .....7-44  
 SHUTTLE SHIFT LEVER.....4-29  
 SIDE-TO-SIDE ROTATION FUNCTION .....4-49  
 SINGLE ACTING AND DOUBLE ACTING CYLINDER..5-21  
 SLOW BLOW FUSE .....7-55  
 SPECIFICATIONS .....3-1

STANDARD SIZE BY IMPLEMENT .....3-10  
 STARTING THE ENGINE.....5-3  
 STEERING WHEEL ADJUSTMENT.....4-35  
 STOPPING THE ENGINE .....5-7  
 STORAGE AND DISPOSAL .....8-1  
 SUNROOF.....4-62  
 SUNSHADE.....4-61  
 SWITCH.....4-5

**T**

TACHOMETER / HOUR METER .....4-15  
 TELESCOPING FUNCTION .....4-35  
 TEMPERATURE CONTROL SWITCH.....4-64  
 THE CAUTIONS WHEN COMING IN AND OUT OF  
 WORK FIELD.....5-16  
 TIRES, WHEELS AND BALLAST .....4-68  
 TRACTOR SERIAL NUMBER.....2-2  
 TRACTOR STORAGE .....8-2  
 TRACTOR TROUBLESHOOTING .....9-4  
 TRAVELING SPEED .....3-8  
 TREAD.....4-70  
 TROUBLESHOOTING .....9-1  
 TURN SIGNAL LAMP.....4-18  
 TURN SIGNAL LAMP (FRONT).....7-60



TURN SIGNAL LAMP (REAR) .....7-60  
 TURN SIGNAL LIGHT SWITCH .....4-8  
 TURNING .....5-15

**U**

UNLOCKING THE DOOR .....4-56  
 UPPER LIMIT POSITION DIAL .....4-46  
 USAGE AND DISPOSAL .....8-4  
 USING TRACTOR AFTER STORAGE .....8-3

**V**

VEHICLE IDENTIFICATION NUMBER .....2-2  
 VENT MODE CONTROL DIAL .....4-64  
 VIBRATION LEVELS OF THE TRACTOR EXPOSI-  
 TION TO VIBRATIONS .....3-6

**W**

WALK AROUND INSPECTION .....7-12  
 WARMING UP .....5-8  
 WARRANTY .....2-6  
 WATER-IN-FUEL WARNING LAMP .....4-25  
 WHEEL INSTALLATION DIRECTION .....4-73  
 WHEEL TORQUE AND DIRECTION .....4-73  
 WHEN DRIVING THE TRACTOR .....1-13

WHEN LOADED BUCKET AND REAR BALLAST ARE  
 INSTALLED .....6-16  
 WHEN OPERATING THE P.T.O .....1-15  
 WHEN PARKING THE TRACTOR .....1-15  
 WHEN STARTING THE ENGINE .....1-9  
 WHEN UNLOADED BUCKET AND REAR BALLAST  
 ARE INSTALLED .....6-16  
 WHEN USING THE 3-POINT HITCH .....1-16  
 WIPER .....4-57  
 WORK LAMP (FRT/RR) .....7-57  
 WORKING LIGHT .....4-57



 **WARNING**

Breathing diesel engine exhaust exposes you to chemicals known to the State of California to cause cancer and birth defects or other reproductive harm.

- Always start and operate the engine in a well-ventilated area.
- If in an enclosed area, vent the exhaust to the outside.
- Do not modify or tamper with the exhaust system.
- Do not idle the engine except as necessary.

For more information go to [www.P65warnings.ca.gov/diesel](http://www.P65warnings.ca.gov/diesel)

TD26-1009