



FOREWORD

Congratulations, and welcome to the fabulous world of **NS4710 / NS6010 / NS4710H / NS5310H / NS6010H** ownership, where serious work is made fun again!

This versatile tractor is a culmination of the entire tractor and diesel knowledge gained by the **Daedong IND. Co., LTD** over the years since 1947 and has been designed with the finest materials and under rigid quality control standards set forth by the **KIOTI** Engineering Department.

Knowledge of tractor operation is essential for many years of dependable service and reliability. To help new owner's familiarize themselves with the **KIOTI NS4710 / NS6010 / NS4710H / NS5310H / NS6010H**, it is the policy of **KIOTI** tractor to provide an owner's manual which includes helpful information about tractor safety, operation and maintenance. If the information you seek is not found in this manual, your **KIOTI** tractor dealer will be happy to help you.

Please feel free to contact **DAEDONG IND. CO.,LTD / DAEDONG-USA, INC.** with your questions/concerns.

< NOTE >

- Make sure to read this manual carefully and keep it handy for future reference.
- When leasing or transferring this tractor, deliver this manual together with the tractor.
- The specifications in this manual are subject to change without notice.







TABLE OF CONTENTS

SECTION

■ SAFETY PRECAUTIONS	1
■ IDENTIFICATION & INTRODUCTION OF WARRANTY	2
■ SPECIFICATIONS.....	3
■ DESCRIPTION OF OPERATING SYSTEM.....	4
■ OPERATION	5
■ 3-POINT HITCH IMPLEMENT AND LOADER OPERATION	6
■ MAINTENANCE.....	7
■ STORAGE AND DISPOSAL.....	8
■ TROUBLESHOOTING.....	9
■ INDEX.....	10





TABLE OF CONTENTS

SAFETY PRECAUTIONS 1-1

PRECAUTIONS BEFORE OPERATION 1-2

 GEnEral PrECauTions 1-2

 rIsK of ovEr TurnInG 1-5

PRECAUTIONS DURING OPERATION 1-8

 WhEn sT ar TInG ThE EnGInE 1-8

 WhEn DrIvInG ThE TraCT or 1-12

 WhEn ParKInG ThE TraCT or 1-13

 WhEn oPEra TInG ThE P.T.o. 1-14

 WhEn usInG ThE 3-PolnT hITCh 1-15

SAFETY PRECAUTIONS DURING SERVICING ... 1-15

**SAFETY PRECAUTIONS WHEN USING THE
LOADER 1-19**

ImPLEmENTS AND ATTACHmENTS 1-21

CLEANING THE TRACTOR 1-24

SAFETY DECAL mAINTENANCE 1-25

 DECal MounTInG loCa Tlon 1-25

 DECals 1-26

CauTions for DECAl MAInTENanCE 1-28

**IDENTIFICATION & INTRODUCTION OF
WARRANTY 2-1**

VEHICLE IDENTIFICATION NuMBER..... 2-2

 ProDuCTIon nuMbEr 2-2

 EnGInE nuMbEr 2-2

 TransMIssIon nuMbEr..... 2-2

ESSENTIAL REPLACEmENT PART 2-3

 oIlS and flUIdS 2-3

 fIl TERS 2-4

 bEl Ts and rubbEr P ar Ts 2-4

 oThEr CoMPonEnTs 2-4

SPECIFICATIONS..... 3-1

GENERAL SPECIFICATIONS 3-2

 ExTernal DIMEnslons 3-2

 GEnEral sPECIfiCa Tions 3-3

TRAVELING SPEED..... 3-6

ImPLEmENT LImITATIONS..... 3-8





TABLE OF CONTENTS

sTanDarD slZE bY IMPIEMEnT	3-8	GloW PlUG laMP	4-18
DESCRIPTION OF OPERATING SYSTEM.....	4-1	ParKInG braKE laMP	4-18
EXTERIOR vIEW	4-3	PTo InDlCa Tor.....	4-18
SWITCH	4-5	4WD InDlCa Tor	4-19
MounTInG loCa Tlon.....	4-5	braKE (onE sIDE) laMP	4-19
KEY sWITCh	4-6	rEGEnEra Tlon WarnInG laMP	4-20
CoMblna Tlon sWITCh	4-7	rEGEnEra Tlon unDER WaY laMP	4-20
hazarD laMP sWITCh.....	4-9	EnGInE ChECK W arnInG laMP	4-20
4WD sWITCh	4-9	WaTEr In fuEl WarnInG laMP	4-22
PTo sETTInG sWITCh	4-10	CrulsE laMP (If EQUIPPED)	4-23
DPf rEGEnEra Tlon sWITCh	4-12	lInKED PEDal laMP	4-23
INSTRUmENT PANEL.....	4-14	CrulsE PT o laMP	4-23
vIEW.....	4-14	Error InDlCa Tor	4-24
fuEl GauGE.....	4-15	OPERATING THE CONTROLS	4-25
EnGInE CoolanT TEMPEra TurE GauGE.....	4-15	Maln shIFt IEvEr.....	4-27
EnGInE oil PrEssurE W arnInG laMP	4-16	ranGE GEar shIFt IEvEr	4-27
baTTER Y CharGInG laMP	4-17	shuTTIE shIFt IEvEr	4-28
hEaD lIGHt HIGH bEaM laMP	4-17	CluTCh PEDal	4-28
Turn sIGnal laMP	4-17	braKE PEDal	4-29
		sTEErInG WhEEl aDjusTMEnT	4-30
		ParKInG braKE IEvEr	4-30





TABLE OF CONTENTS

fooT ThroTTIE	4-31
hanD ThroTTIE IEvEr.....	4-32
lInKED PEDal IEvEr	4-32
DlffErEnTlal loCK PEDal	4-33
sEa T aDjusTMENt	4-34
PosiTion ConTrol IEvEr	4-36
DrafT ConTrol IEvEr.....	4-36
lIfTInG arM (loWEr lInK) sPEED ConTrol Knob	4-37
Double aCTInG IEvEr.....	4-37
7-Pln PoWEr ouTPuT soCKET (oPTIon)	4-38
TIRES, WHEELS AND BALLAST	4-39
GEneral TirE InforMa TIon	4-39
Infla TIon PrEssurE	4-40
TrEaD.....	4-41
WhEEl TorQuE and DirECTIon.....	4-41
aDDITional WEIGHt(oPTional)	4-43
OPERATION	5-1
PRE-OPERATION.....	5-2
INITIAL OPERATION.....	5-3

OPERATING THE ENGINE	5-3
sTar TInG ThE EnGInE	5-3
sToPPInG ThE EnGInE	5-8
WarMInG uP	5-9
juMP sT ar TInG	5-10
OPERATING THE TRACTOR.....	5-11
hoW To DrIvE	5-11
hoW To foLD ThE roPs	5-14
hoW To ralsE ThE roPs To uPrIGhT PosiTion...	5-15
ParKInG.....	5-16
TurnInG	5-18
DrIvInG on sloPE	5-18
ThE CauTions WhEn CoMInG In and ouT of PavED road	5-19
PrECauTions WhIlE DrIvInG on ThE roaD	5-20
loaDInG InT o and unloaDInG ouT of ThE TruCK.....	5-20
PrECauTions WhEn usInG PoWEr sTEERInG ..	5-21
3-POInT hITCh ConTrol sYsTEM	5-23
ExTErIor hYDraulIC ConTrol sYsTEM	5-27
REMOVAL AND INSTALLATION OF 3-POINT HITCH IMPLEMENT (WITH PTO SHAFT).....	6-2





TABLE OF CONTENTS

OPERATION TIP FOR 3-POINT HITCH ELEMENTS 6-5

aDjusTMEnT of lIfT roD	6-5
aDjusTMEnT of ToP lInK	6-6
PrECauTIon for InsT allInG hoW To usE ToP lInK holEs	6-6
aDjusTMEnT of sT abllzEr	6-7
DrafT hITCh anD TrallEr	6-7
InsT allInG PT o shaft	6-9

HANDLING LOADER 6-11

flxa TIon PolnTs for front EnD loadEr	6-12
DrIvInG on sloPE	6-13
joYSTICK valVE Por T	6-14
hYDraulIC bloCK	6-15

mAINTENANCE..... 7-1

mAINTENANCE CHECK LIST 7-3

Dall Y ChECK ITEM	7-3
MalnTEnanCE sChEDulE Char T.....	7-4

LUBRICANTS 7-7

mAINTENANCE CODE 7-8

hoW T o oPEn ThE hooD(a)	7-8
ChECKInG anD aDDInG fuEl(C)	7-8
ChECKInG TransMIssIon fluD IEvEl(D).....	7-9
ChECKInG EnGInE oll IEvEl(E)	7-10
ChECKInG CoolanT IEvEl(f).....	7-11
CIeanInG GrIll, raDla Tor sCrEEEn(G)	7-12
ChECKInG braKE PEDals(h)	7-12
ChECKInG GauGEs, METEr anD EasY ChECK- Er (l).....	7-13
ChECKInG hEaD lIGhT , hazarD lIGhT ETC. (j) ...	7-13
ChECKInG sEa T bEl T anD CabIn (K).....	7-13
ChanGInG EnGInE oll anD rEPlacInG flI TER(l) ..	7-13
rEPlacInG TransMIssIon fluD anD flI TER(M) ..	7-15
ChanGInG front axIE CasE oll(n)	7-17
aDjusTInG braKE PEDal(o)	7-18
lubriCa TIInG GrEasE loCa TIons(P)	7-19
CHECKING WHEEL BOLT / NUT TORQUE(Q)	7-20
fuEl flI TER (s).....	7-20
rEPlacInG alr CIeanEr PriMar Y EIEMEnT(T) .	7-21
ChECKInG fuEl lInEs (u)	7-22
aDjusTInG CluTCh PEDal(u1)	7-23
aDjusTInG fan bEl T TEInslon(v)	7-23





TABLE OF CONTENTS

baTTEr Y(W).....	7-24	USING TRACTOR AFTER STORAGE.....	8-4
ChECKInG InT aKE alr lInE (x)	7-26	USAGE AND DISPOSAL.....	8-4
aDjusTInG ToE-In(Y)	7-26	TROUBLESHOOTING	9-1
ChECKInG raDla Tor hosE anD ClaMP(z).....	7-27	ENGINE TROUBLESHOOTING	9-2
PoWEr sTEErInG lInE(aa)	7-28	TRACTOR TROUBLESHOOTING	9-4
aDjusTInG fronT axIE PlvoT(aD).....	7-28	INDEX.....	10-1
aDjusTInG EnGInE v alVE ClEaranCE(aE)	7-29		
rEPlacInG alr ClEanEr fill TEr (af)	7-29		
flush CoolInG sYsTEM anD ChanGInG CoolanT(aj)	7-30		
anTIfrEEzE(aK)	7-31		
DrainInG W aTEr froM CluTCh housInG(al)	7-32		
bIEEDInG fuEl sYsTEM(aM).....	7-32		
rEPlacInG fusE(an).....	7-33		
sloW bloW fusE(aP)	7-35		
rEPlacInG bulb(aQ).....	7-36		
STORAGE AND DISPOSAL.....	8-1		
TRACTOR STORAGE	8-2		
Dall Y sT oraGE	8-2		
lonG-TErM sT oraGE.....	8-2		





SAFETY AND vEHICLE DAMAGE WARNING

This manual includes information titled as **WARNING**, **CAUTION**, **ImPORTANT** and **NOTE**. These titles indicate the following:



WARNING

This indicates that a condition may result in harm, serious injury or death to you or other persons if the warning is not heeded. Follow the advice provided with the warning.



CAUTION

This indicates that a condition may result in damage to your vehicle or its equipment if the caution is not heeded. Follow the advice provided with the caution.



ImPORTANT

This mark indicates emphasis on notable characteristics of working procedures, and information about technology for easier operation.



NOTE

This indicates that interesting or helpful information is being provided.





ABBREVIATION LIST





























ABBREVIATIONS	DEFINITIONS
4WD	four Wheel Drive
aPI	american Petroleum Institute
asaE	american society of agricultural Engineers, usa
asTM	american society of Testing and Materials, usa
fpm	feet Per Minute
hi-Mid-lo	high speed-Middle speed-low speed
hsT	hydrostatic Transmission
m/s	Meters Per second
PTo	Power Take off
RH/LH	right-hand and left-hand sides are determined by facing in the direction of forward travel
roPs	roll-over Protective structures
m ⁻¹ (rpm)	revolutions Per Minute
s ⁻¹ (r/s)	revolutions Per second
saE	society of automotive Engineers, usa
sMv	slow Moving v ehicle





UNIVERSAL SYMBOLS

various universal symbols have been used on the instruments and controls of your **KIOTI** tractor.
below is a list of the universal symbols and their meanings.

 fuel-level	 Position Control-lowered Position	 low range
 Engine Coolant-Temperature	 hazard Warning lights	 Coolant
 Parking brake	 headlight-low beam	 Preheat
 battery Charging Condition	 headlight-high beam	 QT lamp
 Engine oil-Pressure	 four-Wheel Drive-on	 H:high speed travel light
 Turn signal	 fast	 M:Middle speed travel light
 Power Take-off Clutch Control-on Position	 slow	 L:low speed travel light
 Power Take-off Clutch Control-off Position	 Creep	 N neutral Position
 Differential lock	 high range	 single brake light
	 Middle range	







SAFETY PRECAUTIONS

PRECAUTIONS BEFORE OPERATION	1-2
GEneral PrECauTIons	1-2
rIsK of ovErTurnInG	1-5
PRECAUTIONS DURING OPERATION	1-8
WhEn sTarTInG ThE EnGInE	1-8
WhEn DrIvInG ThE TraCTor.....	1-12
WhEn ParKInG ThE TraCTor.....	1-13
WhEn oPEraTInG ThE P .T.o.	1-14
WhEn usInG ThE 3-PoInT hITCh	1-15
SAFETY PRECAUTIONS DURING SERVICING	1-15
SAFETY PRECAUTIONS WHEN USING THE LOAD- ER.....	1-19
ImPLEmENTS AND ATTACHmENTS.....	1-21
CLEANING THE TRACTOR	1-24
SAFETY DECAL mAINTENANCE	1-25
DECAl MounTInG loCaTIon.....	1-25
DECals	1-26
CauTIons for DECAl MalnTEnanCE.....	1-28

1

1



PRECAUTIONS BEFORE OPERATION

GENERAL PRECAUTIONS

a careful operator is the best operator. Most accidents can be avoided by observing certain precautions. To help prevent accidents, use these safety precautions, and pay attention to the job at hand. If you can prevent an accident, your time will have been well spent.

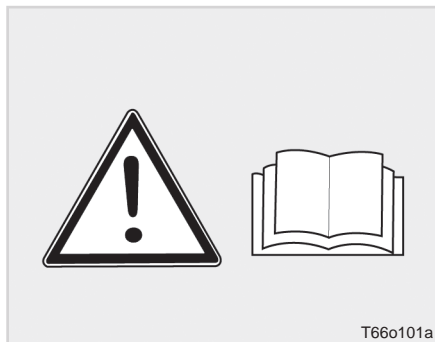

1. It is recommended that you read and understand this entire manual before operation of your new tractor. failure to do so could result in accidents or injury.
2. only persons who are properly trained should be allowed to operate the tractor.
3. read and follow all warning labels and decals affixed to the tractor.
4. replace any missing or damaged decals as soon as it is practical. a list of decals is shown on page 1-25~28.

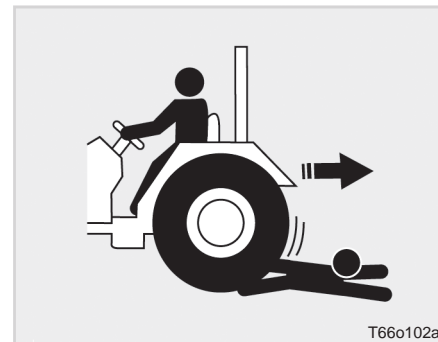

5. Keep safety decals clean of dirt and debris.
6. Watch where you are going at all times so that you are able to avoid obstacles that can cause injury or damage to your tractor.
7. When starting the tractor make sure your path is clear of people to avoid accidents caused by sudden movements.
8. before making reverse movements with your tractor, you should always check to see that the path is clear.

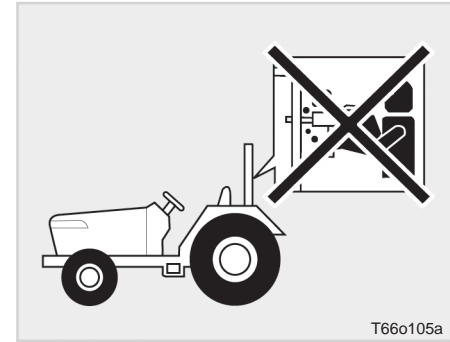
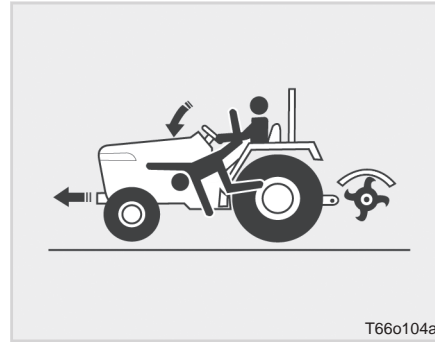
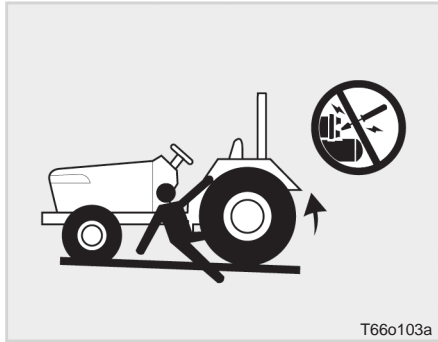

1

9. never operate this tractor or any other agricultural equipment while under the influence of alcohol, drugs or while fatigued.
10. While working in cooperation with other tractors always communicate your intentions.
11. Do not start your tractor by shorting across the starter.
12. never start the engine while standing on the ground.
13. only the operator should ride on the tractor unless a passenger seat is installed. Keep bystanders away from the tractor while in operation.
14. When getting on and off the tractor, handholds and step plates should always be used. This will help to prevent accidental slips trips and falls.
15. be sure to scrape off mud or soil from your shoes before mounting the tractor.
16. all persons using the tractor should have knowledge of its proper operation and should read this manual carefully.
17. never get off the tractor without setting the parking brake, lowering the implement to the ground and shutting of the tractor.
18. no alterations should be made to your **KIOTI** tractor.



20. f or your safety **ROPS** with a seat belt is recommended for all applications.

NOTE

- always use seat belt when the tractor is equipped with a **ROPS** and **CAB**. never use the seat belt when tractor is not equipped with a **ROPS**. (**ROPS**: roll-over Protective structures)

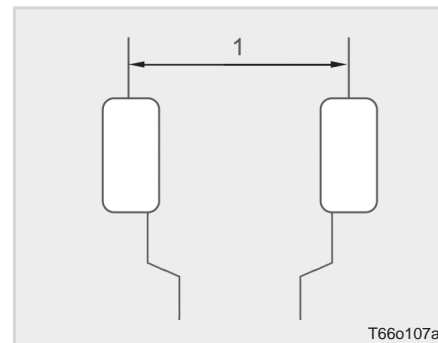

(1) Tread

19. before starting your tractor you should depress the clutch and make sure that all shift levers are in the neutral position and parking brake is applied.

a **ROPS** and **CAB** should never be modified by welding, grinding or cutting, as this can weaken the **ROPS** structure. If any components of the **ROPS** unit is damaged, it must be replaced.

If the **ROPS** unit is removed or loosened for any reason, the parts should be fitted back to their original positions and all bolts should be properly torqued.

21. Extra caution should be taken when driving tractors with narrow tread widths.



RISK OF OVERTURNING

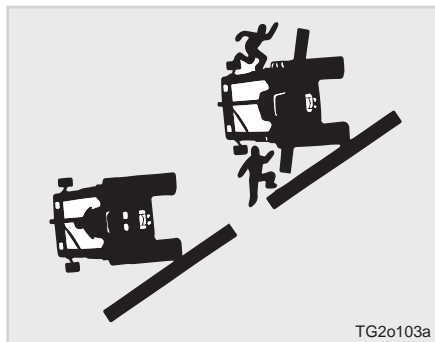
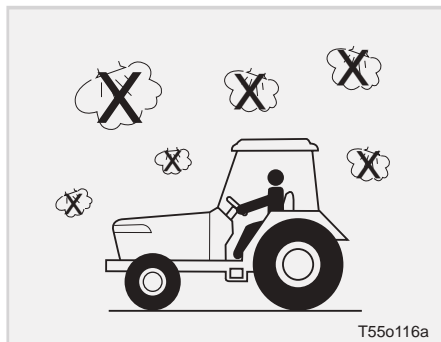

⊕ ImPORTANT

- The safe working practices listed hereunder concerns only a few cases of overturning risk.
- The list is therefore NOT comprehensive of all possible cases.

1

22. This cabin is not certified for chemical proof, never operate the tractor for chemical spray or in the air contaminated by any chemical or equivalent without approved personal safety equip; cartridge respiration/eyeprotection/gloves/etc.

for your safety, tractors must be equipped with original safety belts. In case of overturning, hold firmly the steering wheel e Do noT try to get off the seat until the tractor has come to a stop. If the doors are locked, leave the tractor through the duly indicated emergency exits.





TG2o104a

To avoid side overturning:

- Adjust the wheels to the maximum possible track width for the type of work you are doing.
- Lock both brake pedals together before driving on road.
- Reduce your speed according to work conditions. If the tractor is equipped with a front-end loader, carry the bucket and load as low as possible.

- Reduce your speed before making wide turns. Do not let the tractor jump or bounce on rough terrains. You could lose control.
- DON'T pull a load too heavy for your tractor. It could run away on the down slope or the tractor could jack-knife around a towed load.
- DON'T brake suddenly. Apply brakes smoothly and gradually.
- When going down a slope use the throttle to slow the tractor engine and use the same gear you would use to up the slope. shift into gear before you start downhill.
- Engage four-wheel drive (if equipped); this will give greater stability.

⚠ WARNING

- ***NEVER disengage the clutch or attempt to shift gear after you have started downhill.***



TG2o105a

- Always go up and down slopes following a straight upward or downward line.
- Do not put any overloads on a front implement or a trailer. use suitable counter-weights to keep the tractor stable.
- NEVER use your tractor to round up farm animals.

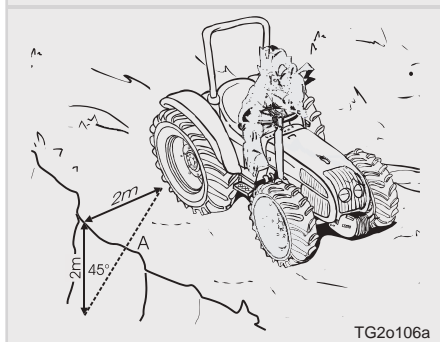
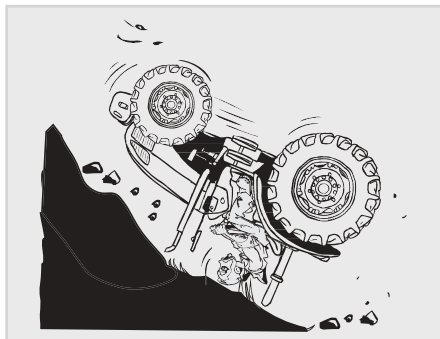

TG2o106a

- When operating near ditches and banks, always keep your tractor behind the shear line. avoid ditches, embankments and river-banks which might cave in.

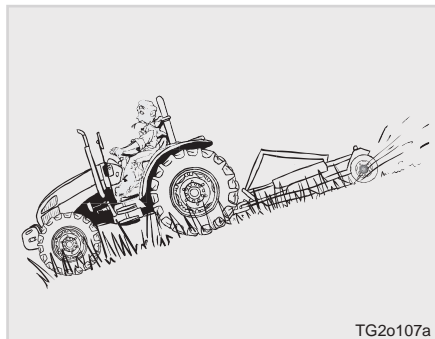

TG2o107a

- If you need cross a steep slope, do not steer uphill, but slow down and take a wide turn. always drive straight up or down a slope, never across it. When travelling up or down a slope, keep the heavy end of the tractor and the implement pointed uphill.



TG2o108a

- When driving across a slope with mounted implements, keep such implements on the uphill side. Do not raise implements. Keep them as low and near to the ground as possible.



PRECAUTIONS DURING OPERATION WHEN STARTING THE ENGINE

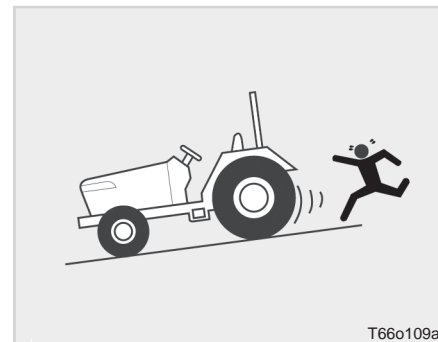
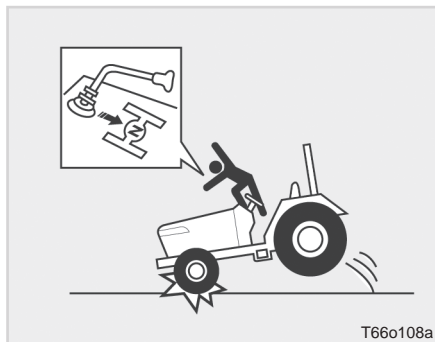
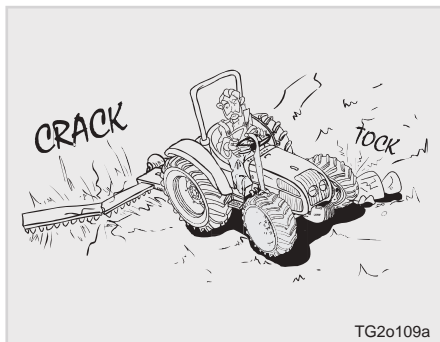

• Avoid crossing steep slopes if possible. If you must do so, avoid any holes or depressions on the downhill side. avoid any stumps, rocks, bumps or raised areas on the uphill side.

1. avoid accidental contact with gear shift levers while the engine is running. Unexpected tractor movements can result in bodily injury.

2. Do not park your tractor on a steep incline, and remember to shut off the engine and P.T.o before dismounting the tractor.

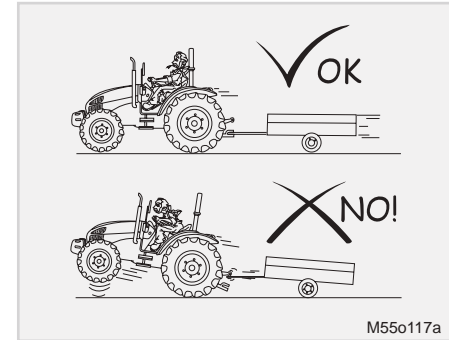
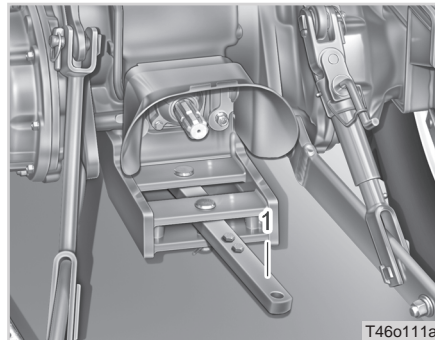
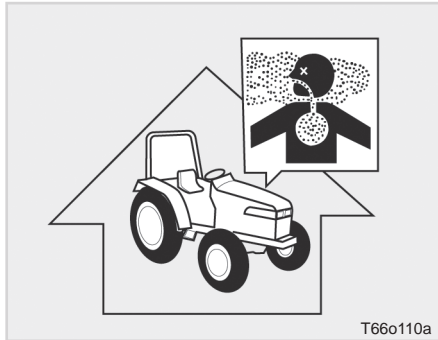

1

(1) Drawbar

(2) Towing hook

3. Do not operate your tractor in an enclosed building without the proper ventilation. Exhaust containing carbon monoxide can cause serious injury or death.

4. Make sure that all pressure lines are tight before starting the tractor.
 5. Pull only from the draw-bar. never hitch anything to the axle housing or any other point except the draw-bar. Pulling from any other location only increase the risk of serious personal injury or death.

6. Improper use of the draw-bar, even if correctly positioned, can cause a rear overturn.
 7. Do not overload an attachment or towed equipment. use proper counterweights to maintain tractor stability. hitch heavy loads to the draw-bar only.

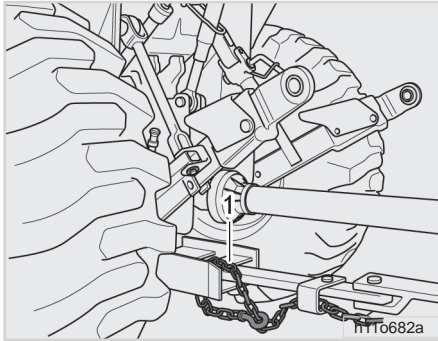

using the proper adaptor parts, attach the chain to the tractor draw-bar support or other specified anchor location. Provide only enough slack in the chain to permit turning. see your Dealer for a chain with a strength rating equal to, or greater than the gross weight of the towed machine.

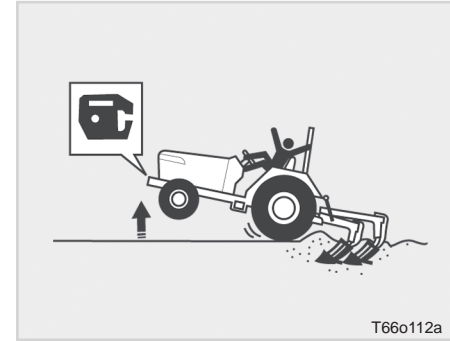

8. Check for correct coupling between tow hook and trailer. see the Towing attachments chapter.
9. use ballast weight as recommended. never add more ballast to compensate a higher load than allowed. reduce load for safety.
10. a safety chain will help control drawn equipment should it be accidentally separated from the draw-bar while transporting.

11. If the front of the tractor tends to rise up when heavy implements are attached to the three point hitch, weights should be installed on the tractor. Do not operate the tractor with a light front end.

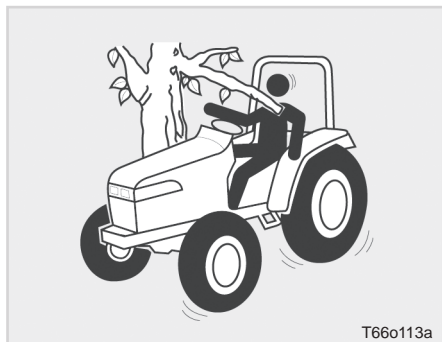

12. always use the proper ballast weight on your tractor when using rear implements.
13. Watch front and rear to avoid obstacles at row ends, near trees and around other obstructions.

⚠ WARNING

• *Drive carefully to avoid injury from penetration of objects from sides, because this machine does not comply to OPS.*

14. Do not leave equipment in the raised position when the vehicle is stopped or unattended.
15. When using implements or attachments with your tractor you should first read their respective owner's manual. You should always keep their safe operation procedures in mind.
16. You should be familiar with your equipment and its limitations.
17. If abused or used incorrectly your tractor can become dangerous to you and bystanders. overloading your tractor or using unsafe equipment can also be dangerous and should be avoided. refer to the "specifications of Implement limitation", which outlines the maximum load for safe tractor operation.

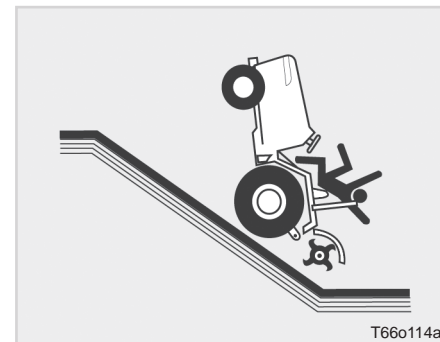

1

18. Driving forward out of a ditch or steep inclines can cause the tractor to tip over backwards. To avoid this you should back out of these positions. four wheel drive tractors can give you a false sense of security in the tractors ability to maneuver out of these positions, so extra caution should be taken.
19. never try to get on or off a moving tractor.



WHEN DRIVING THE TRACTOR

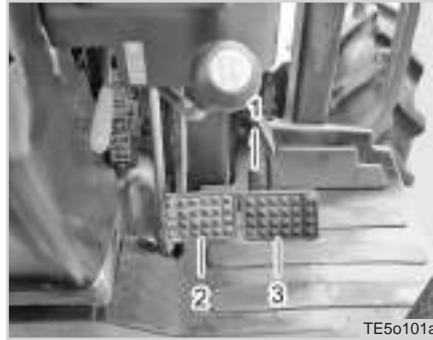
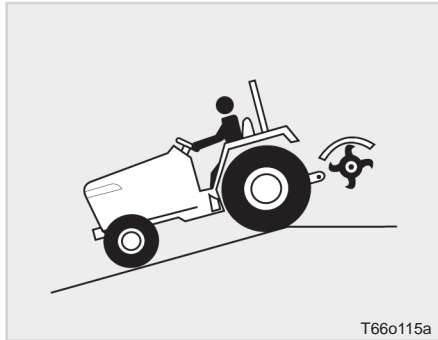

(1) Interlock (2) brake Pedal (l)
(3) brake Pedal (r)

20. When working in groups, always let the others know what you are going to do before you do it.
21. never "freewheel". Disengaging the clutch or shifting into neutral while descending a slope as this could lead to a loss of control.
22. Do not operate near ditches, holes, embankments, or other terrain features which may collapse under the tractor's weight. The risk of tractor upset is even higher when the ground is loose or wet.

1. lock the brake pedals together when traveling at road speeds. brake both wheels simultaneously when making an emergency stop. uneven braking at road speeds could cause the tractor to tip over.

2. always slow the tractor before turning. Turning at high speed may tip the tractor over or cause a loss of control.

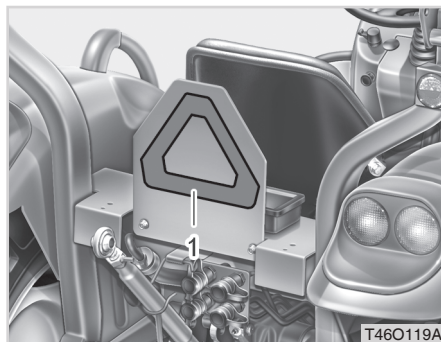

(1) sMv Emblem

3. Make sure that the slow Moving vehicle (sMv) sign is clean and visible. use hazard lights as required.
4. Observe all local traffic and safety regulations.
5. Turn the headlights on. Dim them when meeting another vehicle.
6. Drive at speeds that allow you to maintain control at all times.

7. Do not apply the differential lock while traveling at road speeds. as the tractor may run out of control.
8. avoid sudden movements of the steering wheel as this can cause a loss of control of the tractor. This risk is especially great when traveling at road speeds.
9. Do not operate an implement while the tractor is on the road. lock the three point hitch in the raised position.
10. When towing other equipment, use a safety chain and place an sMv emblem on it as well.

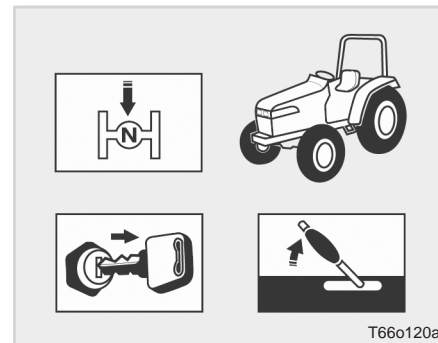
WHEN PARKING THE TRACTOR

1

1. Disengage the P.T.o , lower all implements, place all control levers in the neutral position, set the parking brake, stop the engine and remove the key.

WHEN OPERATING THE P.T.O.

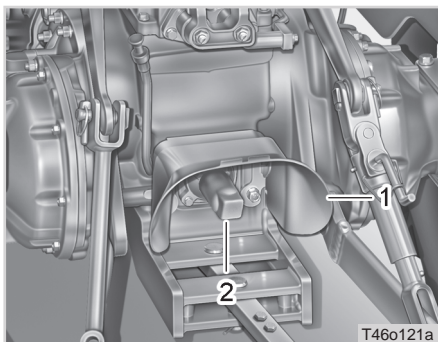

- (1) PTo shield
(2) PTo shaft Cap

1. Make sure the tractor is completely stopped, gears are in neutral and all moving components have completely stopped before connecting, disconnecting, adjusting, cleaning or servicing any P.T.o driven equipment.
2. Keep the P.T.o shaft cover in place at all times. replace the P.T.o shaft cap when the shaft is not in use.

3. before installing or using P.T.o driven equipment, read the manufacturer's manual and review the safety labels attached to the equipment.

⚠ WARNING

- *Before driving an implement through the PTO, always make sure that all bystanders are well away from the tractor.*
- *When using the PTO drive with a stationary tractor, always make sure that the gears are in neutral and that the parking brake is applied.*
- *Before starting up any PTO-driven implement hitched to the three-point linkage, lift the implement to its full height and check that at least 1/4 of the total length of the telescopic section of the drive shaft is engaged.*
- *Ensure that implements and attachments are properly installed and that the tractor and implement PTO RPM ratings match.*

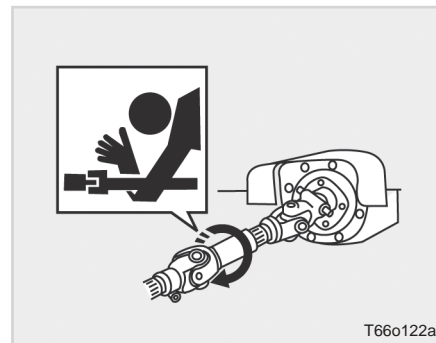

4. When operating stationary P.T.o driven equipment, always apply the tractor parking brake and place chocks behind and in front of the rear wheels. stay clear of all rotating parts.
5. Do not attach a PTo driven implement if the implements safety shields are damaged or not in place. rotating shafts are an entanglement hazard.

WHEN USING THE 3-POINT HITCH

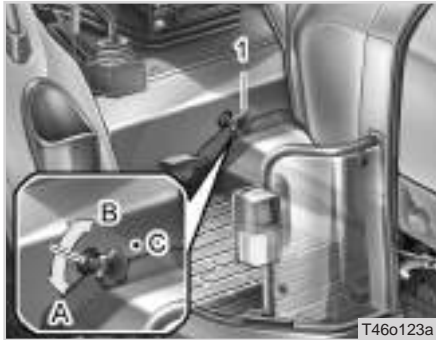

T46o123a

- (1) 3-point hitch lowering speed knob
 (a) "fasT" (C) "loCK"
 (b) "sloW"

1. use the 3-point hitch only with equipment designed for 3-point hitch usage.
2. When using a 3-point hitch mounted implement, be sure to install the proper counterbalance weight on the front of the tractor.
3. When transporting on the road, set the implement lowering control in the "loCK" position to hold the implement in the raised position.

SAFETY PRECAUTIONS DURING SERVICING



T66o124a

In order to service your tractor you must park it on a flat level surface, set the parking brake, place the gear shift lever in neutral and stop the engine.

1. Do not smoke while working around the battery or when refueling your tractor. Keep all sparks and flames away from the battery and fuel tank. The battery presents an explosive hazard because it gives off hydrogen and oxygen etc. especially when recharging.



T66o125a

2. allow the tractor time to cool off before servicing any part that may have become hot while the tractor was running.
3. You must always stop the engine before refueling the tractor. avoid overfilling the tractor or spilling the fuel.
4. before jump starting a dead battery, read and follow all of the instructions. (refer to the page 5~9)
5. It is recommended to keep a first aid kit and fire extinguisher handy at all times.

1

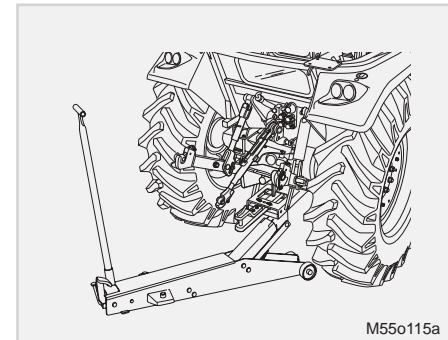
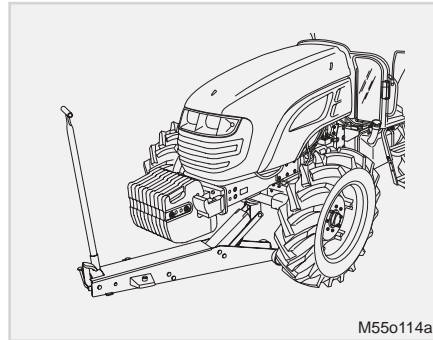
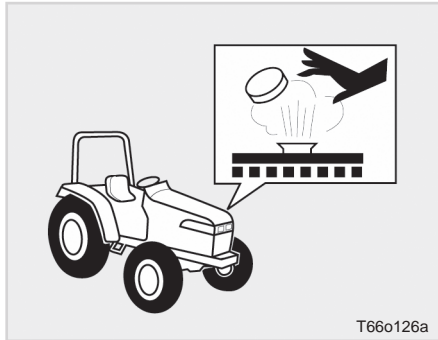

6. Do not remove the radiator cap while the coolant is hot. When cool, slowly rotate the cap to the first stop and allow sufficient time for excess pressure to escape. After all the pressure is released, remove the cap completely. If your tractor is equipped with a coolant recovery tank, add coolant there rather than to the radiator.

7. If the tractor must be lifted for servicing, take it to a suitably equipped workshop.

8. Carry out the following operations before any operation about the tractor: Engage the four-wheel drive, the first gear and the parking brake and put chocks to the wheels touching the ground.

9. Before lifting the tractor, avoid its swinging by means of wooden wedges applied to the front axle.

10. Use jack lifts of suitable capacity and apply them at the center of the front and rear axles while paying due attention to weight distribution.

11. No decals for the lifting point are applied on the tractor, as they would be too difficult to apply in the available spaces and would be all too easily removed or effaced during normal operation of the tractor.

NOTE

- apply the jack lift to the lifting points according to the type of operation and follow the safety procedures given before.

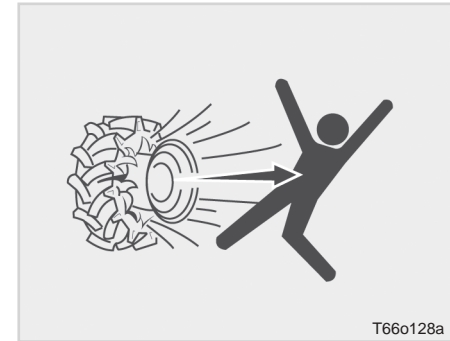
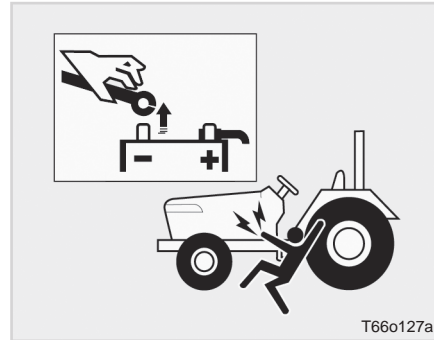

1

- When working with your tractors electrical components you must first disconnect the battery cables.
- To ensure that there are no accidents from sparks you must first disconnect the negative battery cable.
- Tire mounting should be done by qualified professionals, with the proper equipment.
- Maintaining correct tire pressure is important for the life of your tires. Do not inflate the tires above the recommended pressure specified in the owner's manual. (see page 4-33)
- securely support the tractor when changing wheels or the wheel tread width.

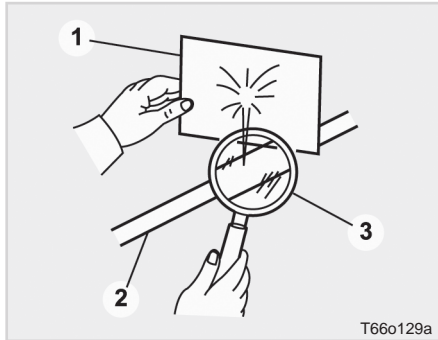

(1) Cardboard
(2) hydraulic line
(3) Magnifying Glass

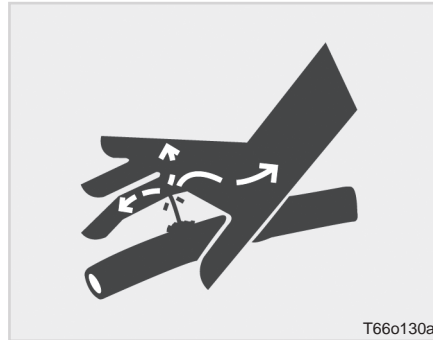

T66o130a

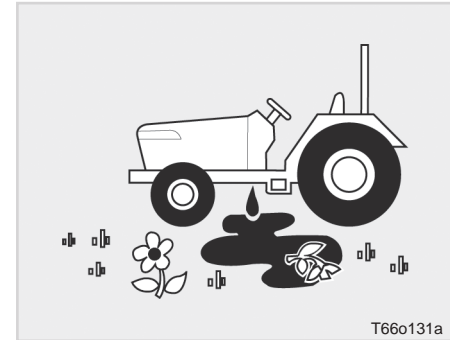

T66o131a

17. Make sure that wheel bolts have been tightened to the specified torque.
18. Escaping hydraulic fluid under pressure has sufficient force to penetrate skin, causing serious personal injury. be sure to release all residual pressure. before disconnecting hydraulic lines.

before adding pressure to the hydraulic system, make sure that all connections are tight and that all lines, pipes and hoses are free of damage.

19. fluid escaping from pinholes may be invisible. Do not use hands to search for suspected leaks; use a piece of cardboard or wood, instead. use of safety goggles or other eye protection is also highly recommended. If injured by escaping fluid, see a medical doctor at once. This fluid can produce gangrene and/or severe allergic reaction.

20. Keep environmental pollution in mind. When replacing coolant or oil, dispose of it the right way. be sure to observe all relevant regulations when you dispose of the engine oil, transmission oil, fuel, coolant, filters and battery.



SAFETY PRECAUTIONS WHEN USING THE LOADER

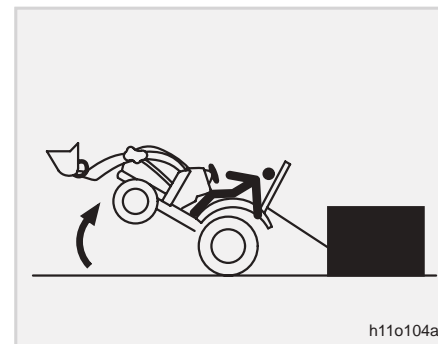
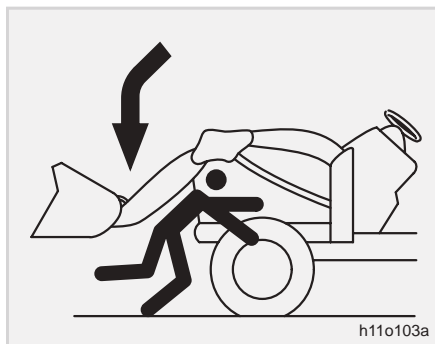
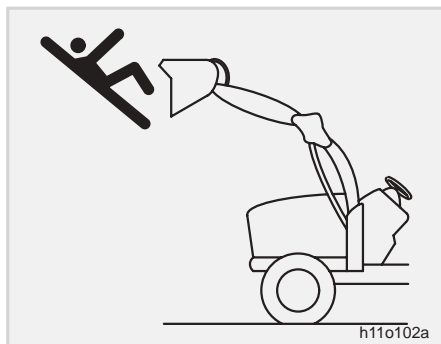

1

1. never let anyone get in the loader and use the loader as a work-bench. otherwise, it may lead to a fatal injury or even death.

2. Do not stand under the lifted loader or get close to it. also, lower the loader arm onto the ground before leaving the tractor. otherwise, it may lead to a fatal injury or even death.

3. The loader can be turned over if a draw-bar is improperly loaded. Make sure to use a draw-bar proper for the 3-point hitch lower link. otherwise, it may lead to an injury or even death.



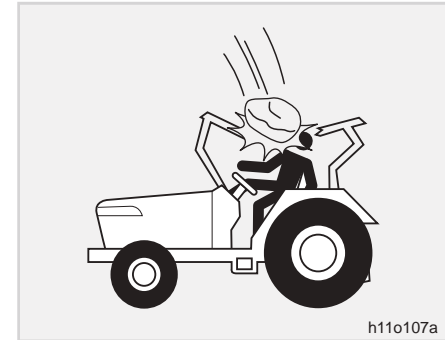
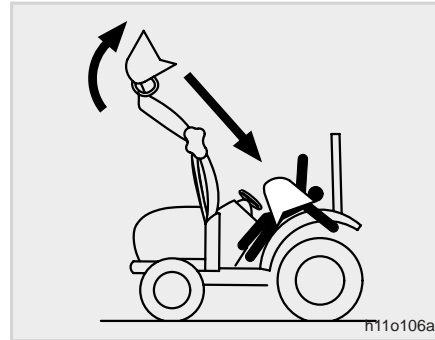
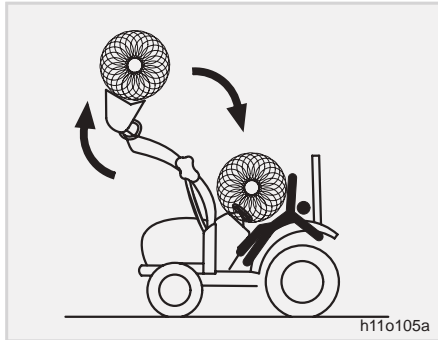

4 never carry a big object with the loader unless a proper implement is attached. Keep a carried object low during driving. otherwise, it may lead to an injury or even death.

5. When attaching or detaching the loader, fix all parts which are connected to the bucket and boom. The bucket or boom can be accidentally dropped down, leading to an injury or even death.

⊕ ImPORTANT

- **ROPS (Roll Over Protective Structure), sun canopy not a FOPS. (Falling Object Protective Structure)**

It never can protect the riders against falling objects.

Avoid driving the vehicle into a dangerous area such as falling rocks zone.

ImPLEMENTS AND ATTACH- MENTS

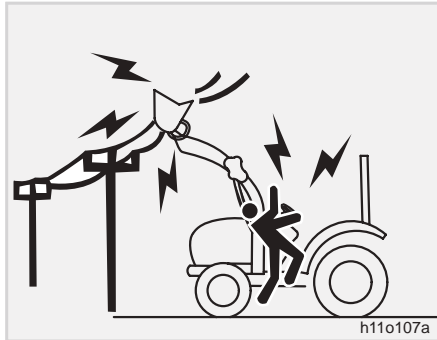

6. Do not allow loader arms or attachment to contact electrical power lines. Electrocution will cause serious injury or death.



7. Keep bystanders away. no riders.

⚠ WARNING

- *Use exclusively front loader approved by the tractor's manufacturer, with CE mark and parallelogram type.*
- *The installation and modification of the tractor must be carried out with the highest technical standards by specialised workshops with qualified personnel. Such workshops must be able to guarantee and attest the risk analysis provided for in the machinery Directive 2006/42/EC concerning the foreseen and predictable use of the tractor with front loader, in order to carry out all required adaptations of the tractor.*
- *Use the front loader and all supplied equipment as prescribed by the loader's operator manual.*

1

⊕ ImPORTANT

- Keep the loader's operation manual together with the tractor's manual, always at hand in the storage compartment of the tractor.
- Before driving or operation your tractor, it is mandatory to read this manual very carefully, with special attention to the chapter concerning safety rules.

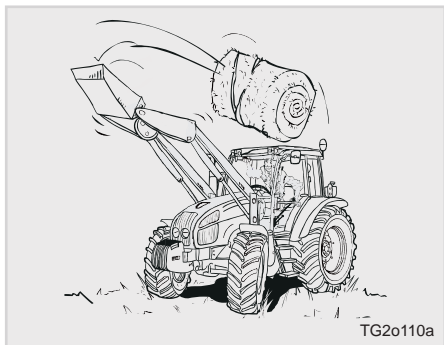

⚠ WARNING

- *Use of the front loader and of the tractor equipped with front loader, if not correctly carried out, and handling not secured loads constitute a serious danger for the operator and everyone standing by, because of the danger of falling objects.*

- Three-point hitch and side mounted implements make a much larger arc when turning than towed equipment. Make certain to maintain enough clearance for safe turning.
- To use mounted, semi-mounted or towed equipment and trailers it is required to use exclusively CE marked implements, after reading their operation handbooks carefully, giving maximum attention to risks connected with their association to the tractor.
- Implements must be hitched to the tractor by means of the three-point linkage. It is therefore necessary to check couplings for compatibility according to their classes.

The implement has to be fitted with suitable supports in order to avoid tipping or accidental shifting during hitching. always check three-directional fastening to the tractor of the mounted or semi-mounted implement, to avoid dangerous swinging

and shaking during transport and work that could jeopardize the stability of the tractorimplement assembly.

- The cardan shaft must be always CE-marked, provided with suitable guards and suitable to tractor-implement coupling. follow all directions of the operation manual, concerning both the fastening according to connection direction and safety rules to avoid rotation of protections (chains) and overlaying of the telescopic tubes. also keep articulation angles.

! WARNING

- ***When a tractor with safety frame is equipped with a front loader, there is still a risk if the implement is improperly used. This risk is due to objects falling from above. The operator has no protection against this risk.***

To reduce risks, the following precautions should be used.

- only use loader equipped with a load self-levelling system, i.e. of the parallelogram type.
- only use specific implements for the operation to be performed. strictly follow the directions and warnings in the loader's operation manual.
- use the machine and the implement with caution, drive on plane ground and avoid pits, excavations and ditches. Do not turn, start or stop abruptly.
- If a front loader is mounted, it is advisable to use a tractor with cab or with a 4-post frame with foPs safety system. The loader installer should carefully analyze all risks and make all required adjustments.

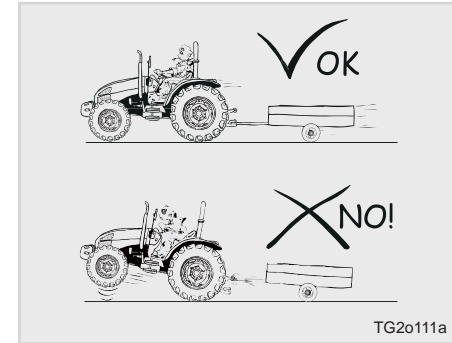

- Hitch loads to the drawbar only. Towing or attaching to other locations may cause the tractor to overturn.
- Improper use of the drawbar, even if correctly positioned, can cause a rear overturn.
- DO NOT overload an attachment or towed equipment. use proper counterweights to maintain tractor stability. hitch heavy loads to the drawbar only.

CLEANING THE TRACTOR

- Check for correct coupling between tow hook and trailer. see the Towing attachments section.
- Use ballast weight as recommended. nEvEr add more ballast to compensate a higher load than allowed. reduce load.
- Keep work surfaces and engine compartments clean. • Before cleaning the machine, always lower implements to the ground, engage the first gear, engage the parking brake, turn the engine off and remove the key.
- Always use specific personal safety devices for each service operation.
- Clean steps, pedals and floor. Remove grease or oil. brush away dust or mud. In winter, scrape away snow and ice. remember - slippery surfaces are dangerous.
- Avoid using petrol, paraffin, paint thinner etc. when cleaning plastic parts, e.g.; console, instrument cluster, monitors and gauges etc. use onl Y water, mild soap and a soft cloth when you clean these parts.using petrol, paraffin, paint thinner etc., will cause cracking or deformation of the part being cleaned.
- Remove and put away any tools, buckets, chains and hooks.



SAFETY DECAL mAINTENANCE DECAL mOUNTING LOCATIOn



1

TE7o101a



DECALS

(1) Part no. : T2555-52282



(3) Part no. : T4625-52351



(5) Part no. : TC26-0388a

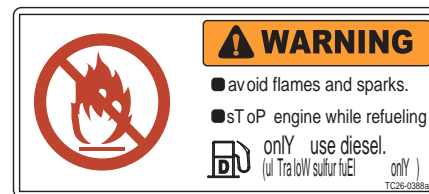

(2) Part no. : T2615-55112

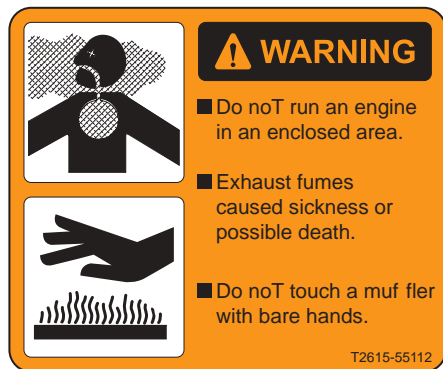

(4) Part no. : T4938-53551



(6) Part no. : T4182-53191

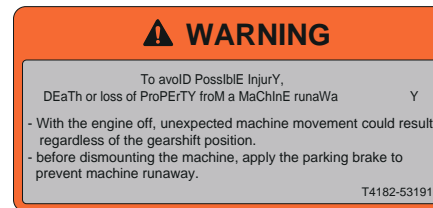

(7) Part no. : f6800-29112

This tractor is equipped with a DPf(Diesel Particulate filter). use the Cj-4 grade Engine oil. otherwise, cause DPf failure .



regeneration underway lamp

- When DPf starts to regenerate, you can see it.
- When on regeneration, Do not touch the part of DPf because it is very hot.
- Keep flammables materials and people away from exhaust pipe.
- Please keep higher 1700rpm to finish regen fully until underway lamp is off.

- Park to safety area and Clear around Exhaust Pipe.
- operating Condition
 - Depress brake pedal and lock it.
 - Put gearshift lever in neutral position.
 - hand/foot accel. Pedal "Idle Min".
 - Warm up the engine for 1-2 minutes.
 - Do not depress clutch pedal.
 - Press switch over 2 seconds.
- Then rPM automatically increase and decrease until regen is completed
- normally, it will take 30-40 minutes.



When you see this warning lamp

(8) Part no. : T4938-52351

WARNING

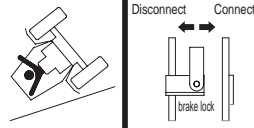

Disconnect Connect

brake lock

- always lock the left and right brake pedals together before driving on the road.
- activating only one brake at higher speeds could cause loss of control.

T4938-52351

(9) Part no. : T2555-52141

WARNING



- before starting and operating
 - Know the operating and safety instructions in the operators manual and on the tractor.
 - Clear the area of bystanders.
 - locate and know operation of controls.
 - fasten your seat belt.
- start engine only from operators seat with transmission in neutral, PTO disengaged and hydraulic controls in lowered position.
- slow down on turns, rough ground and slopes to avoid upset.
- Do not permit anyone but the operator to ride on the tractor. There is no safe place for riders.
- lock brakes together , use warning lights and sMv emblem while driving on roads.
- lower equipment, place gear shift levers in neutral, stop engine and apply parking brake before leaving tractor seat.
- avoid accidental contact with rear shift lever while engine is running. unexpected tractor movement can result.

fa llurE . To follow any of THE instructions above Can Cause sERious Injury To THE oPeratOr or oThER PErsons.

(replacement manuals are available from your local dealer)
T2555-52141

(10) Part no. : T2555-52262

DANGER

Pull only from approved drawbar or lower links of 3-point linkage at horizontal position or below.

rotating driveline contact may cause serious injury or death.



Keep all driveline, tractor and equipment shield in place during operation.

T2555-52262

1

(11) Part no. : T2555-52353

DANGER

- Improper operating of tractor can rollover or upset.
- Do not operate vehicle without raised roPs and locking pins in position.
- Do not attach ropes or chains to roPs for pulling.
- lower the roPs for low clearance on ...
 - Do not fold roPs with a canopy attached.
 - seat belt is not recommended with roPs lowered
 - no protection is provided in lowered position.
- raisE roPs and insert locking pin immediately after low clearance use, or for transport
- alw aYs wear seat belt with roPs in raised position. failure to comply will result death or serious injury

T2555-52353

(12) Part no. : TD26-1009a

 WARNING
<p>Breathing diesel engine exhaust exposes you to chemicals known to the State of California to cause cancer and birth defects or other reproductive harm.</p> <ul style="list-style-type: none"> ● Always start and operate the engine in a well-ventilated area. ● If in an enclosed area, vent the exhaust to the outside. ● Do not modify or tamper with the exhaust system. ● Do not idle the engine except as necessary. <p>For more information go to www.P65warnings.ca.gov/diesel</p> <p style="text-align: right;">TD26-1009</p>

CAUTIONS FOR DECAL MAINTENANCE

safety decals are attached to the tractor for safe operation. Make sure to follow the instruction on the decals as well as the following instruction.

 CAUTION
<ul style="list-style-type: none"> ● Keep the decals clean and intact. If any decal is dirty, wash it with soap and dry with a soft cloth. ● Never use a solvent, such a thinner or acetone, since it can ruin the decals. ● Do not spray high-pressure water directly onto the decal. The decal may fall off the tractor.

 ImPORTANT
<ul style="list-style-type: none"> ● If a decal is damaged or lost, contact your local KIOTI dealer immediately to install a new decal. ● make sure to attach the decal to the correct position cleanly without bubbles after cleaning its mounting surface. ● If a decal is attached to a component to be replaced, replace the decal as well.



IDENTIFICATION & INTRODUCTION OF WARRANTY

VEHICLE IDENTIFICATION NUMBER..... 2-2

ProDuCTIon nuMbEr	2-2
EnGInE nuMbEr.....	2-2
TransMIssIon nuMbEr	2-2

ESSENTIAL REPLACEMENT PART 2-3

olls anD flUIdS	2-3
flITErS	2-4
bEITs anD rubbEr P arTs.....	2-4
oThEr CoMPonEnTs.....	2-4

2

2

VEHICLE IDENTIFICATION NUMBER PRODUCTION NUMBER



(1) S/N Identification Plate

This number is to identify the vehicle, and its plate is attached on the front right side of the front axle frame.

ENGINE NUMBER



(1) Engine Serial Number

The engine number is stamped on the cylinder block surface which is rear side of the alternator on the left side of the engine.

This number indicates the engine type, displacement, injection timing, and date of manufacture.

TRANSMISSION NUMBER

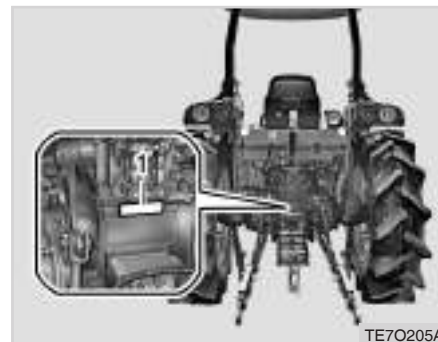

(1) Transmission Serial Number

The transmission number is stamped on the transmission case on the P.T.O cover.

ESSENTIAL REPLACEMENT PART OILS AND FLUIDS

• Identification No.

• Engine Serial No.

• Transmission Serial No.

• Date of Purchase

To be filled in by purchaser.



Various oils and fluids are used in this tractor for operation, lubrication, cooling, and anti-corrosion of various parts.

If oil or fluid is insufficient, contaminated or degraded, it can cause poor performance, incorrect operation, and seized parts of the tractor, leading to malfunctions.

Regularly add or change the fluid specified on the right to keep the tractor in perfect condition.

2

No.	ITEM	SPECIFICATION	L (U.S.gal.)
1	Engine oil	API CJ grade above saE 15W40 / 10W30 / 10W40	7.4 (1.95)
2	Transmission fluid	saE 15W40 DaEDonG uTf55 Exxonmobil Mobilfluid 424 BP: Tractran UTH Exxonmobil Hydraulic 560 Shell: Donax TD	NS4710/6010 : 43 (11.36) NS4710H/5310H/6010H : 36 (9.51)
3	Grease	SAE multi purpose type grease	A little
4	Antifreeze	Fresh clean water with ethylene glycol (50 : 50)	7.7 (2.0)

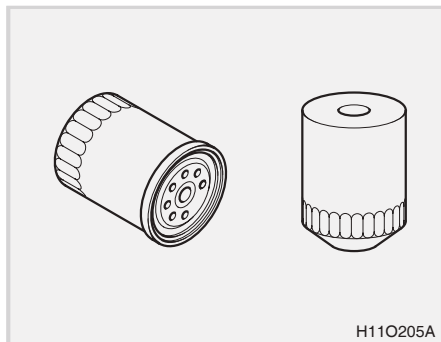
FILTERS

Filters for the engine, transmission, air cleaner, and A/C are consumables that purify oil and air. Make sure to replace these items when changing oil.

PART NO	DESCRIPTION	QTY
E6201-32443	Engine oil filter	1
T5710-38031	Hydraulic filter	1
Eh35-0011a	Filter, Fuel	1
E7230-11801	Air filter	1

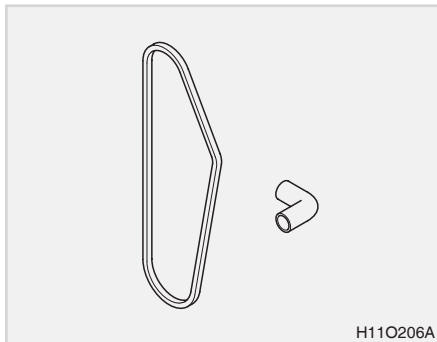
BELTS AND RUBBER PARTS

Belts, hoses and boots, which are made of rubber, get weakened and cracked as they age. If these parts remain in this state, they can be broken "OFF", leading to a serious problem in the tractor. Therefore, regularly replace the items indicated on the right to prevent an accident.

PART NO	DESCRIPTION	QTY
F6820-72531	Fan belt	1

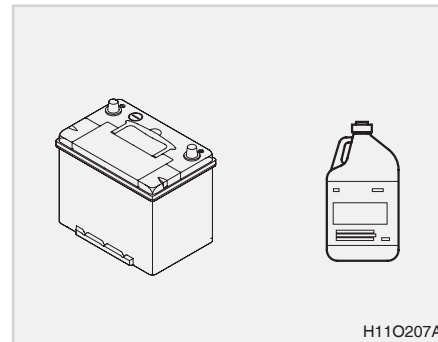
OTHER COMPONENTS

The battery is a very important consumable component that supplies power to the alternator when the engine is started.

Therefore, make sure to check its discharging condition daily, including its life span and electrolyte condition.

PART NO	DESCRIPTION	QTY
C7910-42204	Battery	1



SPECIFICATIONS

GENERAL SPECIFICATIONS 3-2
 ExTErnal DIMEnslons 3-2
 GEnEral sPECIfICaTions 3-3

TRAVELING SPEED 3-6

ImPLEmENT LImitATIONS 3-8
 sTanDarD slZE bY IMPIEMEnT 3-8

3

3

GENERAL SPECIFICATIONS

EXTERNAL DIMENSIONS

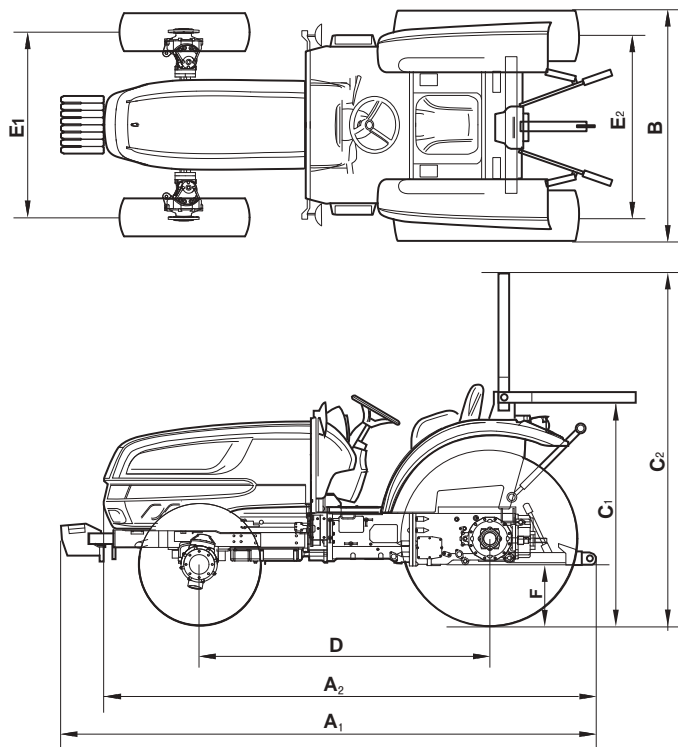

h11o301a

mm (in.)

ITEM	MODEL	
	NS4710(H) NS5310H	NS6010(H)
1. overall length (a1)	3,820 (150.4)	←
2. overall length (a2)	3,465 (136.4)	←
3. overall width (b)	1,705 (67.1)	1,684 (66.3)
4. overall height (C)	2,587 (101.9)	2,648 (104.3)
5. Wheel base (D)	1,918 (75.5)	←
6. Tread (E1)	1,297 (51.1.)	1,381 (54.4)
7. Tread (E2)	1,360 (53.5)	1,334 (52.5)
8. Ground clearance (f)	340 (13.4)	390 (15.4)

※ E1 : front wheel tread

E2 : rear wheel tread

※※ These dimensions are measured with standard tires (aG) installed on the roPs model tractor.

GENERAL SPECIFICATIONS

ITEM			mODEL				
			NS4710	NS6010	NS4710H	NS5310H	NS6010H
Engine	Model		3hT-s4TM45a	3hT-s4TM58a	3hT-s4Th45a	3hT-s4Th50a	3hT-s4Th58a
	no.of cylinders		3	←	←	←	←
	Total displacement	cc (cu in.)	1,826 (111.4)	←	←	←	←
	bore & stroke	mm (in.)	87 x 102.4 (3.4 x 4.0)	←	←	←	←
	Engine Gross Power	kW (hP)	33.6 (45)	43.0 (57.7)	33.5 (44.9)	37.5 (50.3)	43.0 (57.7)
	rated P T o Power	kW (hP)	35.6 (47.8)	←	←	←	←
	rated revolution	rpm	2,600	←	←	←	←
Capacity	fuel tank		ℓ (U.S.gal.)	50 (13.2)	←	←	←
	Transmission oil		ℓ (U.S.gal.)	43 (11.36)	←	36 (9.51)	←
	front axle oil		ℓ (U.S.gal.)	8.5 (2.25)	←	←	←
	Engine Oil (filter include)		ℓ (U.S.gal.)	7.4 (1.95)	←	←	←
	Engine Coolant		ℓ (U.S.gal.)	7.7 (2.03)	←	←	←
Drive Train	Main Clutch Type		Dry type single stage	←	none	←	←
	Transmission	shuttle Type	synchro shuttle	←	hsT	←	←
		Main Gear shift	synchromesh 4 stages	←	-	-	-

3

ITEM				mODEL				
				NS4710	NS6010	NS4710H	NS5310H	NS6010H
Drive Train	Transmission	range Gear shift		Constant Mesh 3 stages	←	3 range	←	←
		no. of speeds		f12 x r12	←	Infinite	←	←
	Traveling speeds (aG)	forward	km/h (mph)	1.5~26.8 (0.9~16.7)	1.6~29.9 (1.0~18.6)	0~28.1 (0~17.5)	←	0~31.3 (0~19.4)
		reverse	km/h (mph)	1.3~23.8 (0.8~14.8)	1.5~26.5 (0.9~16.5)	0~19.7 (0~12.2)	←	0~21.9 (0~13.6)
	front wheel drive system			hydraulic	←	←	←	←
	Main brake Type			Wet Disc Type	←	←	←	←
	Mechanical Differential lock			rear standard	←	←	←	←
Tire size	agricultural	front	8 - 16	9.5 - 16	8 - 16	←	9.5 - 16	
		rear	13.6 - 24	13.6 - 28	13.6 - 24	←	13.6 - 28	
hydraulic	Pump	lpm (cc/rev)	62.4 (Main: 36.4 / steering: 26)	←	←	←	←	
	steering		Power steering	←	←	←	←	
	3 Point lift Control Type		Position, Draft, Mixed Control	←	←	←	←	
	3-point hitch type		Category I	←	←	←	←	

ITEM			mODEL				
			NS4710	NS6010	NS4710H	NS5310H	NS6010H
hydraulic	lift Capacity	@24 in. behind lift point kgf (lbs)	1,131 (2,493)	←	←	←	←
		@ lift point kgf (lbs)	1,334 (2,940)	←	←	←	←
	no.of standard remote valves (rear)		1	←	←	←	←
PTO	rear	Type	Independent	←	←	←	←
		PTO shaft specifications	saE 1-3/8, 6 spline	←	←	←	←
		1 / 2 / 3 stages rpm	540	←	←	←	←
Min. turning radius (With one rear wheel braked) m (ft)			3.37 (11.04)	←	←	←	←
Weight with roPs and aG tires kgf (lbs)			1,827 (4,028)	←	←	←	←
Max. Draw-bar vertical load kgf (lbs)			-	←	←	←	←
Max. Trailer loading weight kgf (lbs)			-	←	←	←	←

※ The specifications are subject to change without notice.

TRAVELING SPEED

[MANUAL]

Km/h (mph)

TIRE		13.6-24		13.6-28	
OPERATING THE LEVER		HIGH / LOW SPEED		HIGH / LOW SPEED	
RANGE	mAIN	FORWARD	REvERSE	FORWARD	REvERSE
low(l)	1	1.5 (0.9)	1.3 (0.8)	1.6 (1.0)	1.5(0.9)
	2	2.1 (1.3)	1.8 (1.1)	2.3 (1.4)	2.0 (1.3)
	3	2.6 (1.6)	2.3 (1.5)	2.9 (1.8)	2.6 (1.6)
	4	3.6 (2.2)	3.2 (2.0)	4.0 (2.5)	3.6 (2.2)
Middle(M)	1	3.8 (2.3)	3.3 (2.1)	4.2 (2.6)	3.7 (2.3)
	2	5.3 (3.3)	4.7 (2.9)	5.9 (3.6)	5.2 (3.2)
	3	6.8 (4.2)	6.0 (3.7)	7.5 (4.7)	6.7 (4.2)
	4	9.2 (5.7)	8.1 (5.1)	10.2 (6.3)	9.1 (5.6)
hgh(h)	1	10.4 (6.5)	9.2 (5.7)	11.6 (7.2)	10.3 (6.4)
	2	14.5 (9.0)	12.9 (8.0)	16.2 (10.1)	14.4 (8.9)
	3	18.7 (11.6)	16.6 (10.3)	20.8 (12.9)	18.5 (11.5)
	4	25.3 (15.7)	22.5 (14.0)	28.2 (17.5)	25.1 (15.6)

※ The specifications are subject to change without notice.



[HST]

Km/h (mph)

TIRE	13.6-24		13.6-28	
OPERATING THE LEVER	HIGH / LOW SPEED		HIGH / LOW SPEED	
RANGE	FORWARD	REVERSE	FORWARD	REVERSE
low(l)	6.2 (3.9)	4.4 (2.7)	7.0 (4.3)	4.9 (3.0)
Middle(M)	10.8 (6.7)	7.5 (4.7)	12.0 (7.5)	8.4 (5.2)
hgh(h)	26.6 (16.5)	18.6 (11.6)	29.6 (18.4)	20.7 (12.9)

3

ImPLEmENT LImITATIONS

STANDARD SIZE BY ImPLEmENT

This **KIOTI** tractor has been thoroughly tested for proper performance with implements sold or approved by **KIOTI**. Use with implements which are not sold or approved by **KIOTI** and which exceed the maximum specifications listed below, or which are otherwise unfit for use with this **KIOTI** tractor may result in malfunctions or failures to the tractor, damage to other property and injury to the operator or others. [Any malfunctions or failures to the tractor resulting from use with improper implements are not covered by the warranty.]

model \ Item	Tread (max. width)		Lifting Capacity max. loading weight W_0 (24 in. aft of hitch)
	Front	Rear	
all	1,381 mm (54.4 in.)	1,334 mm (52.5 in.)	1,131 kg (2,493 lb)

model	Item	Actual figures		Trailer loading weight W_3 max. capacity
		Implement weight W_1 and / or size	Max. Drawbar load W_2	
all	as in the following list (shown on the next page)		735 kg (1,620 lbs.)	4,700 kg (10,361 lbs.)
lifting Capacity max. loading weight The max. allowable load which can be put on the 24 in. aft of hitch : W_0 Implement weight The implement's weight which can be put on the lower link : W_1 Max. drawbar load W_2 Trailer loading weight The max. loading weight for trailer (without trailer's weight) : W_3				

3

NOTE : Implement size may vary depending on soil operating conditions.

ImPLEmENT	DESCRIPTION	REmARKS
loader	Max. bucket width	84 in. (2,134 mm) bucket
backhoe with sub frame	Max. Diging depth	n/a, 3-point mounting is not recommended by DaEDonG
Tiller	Max. Cutting width	not recommended unless rated for 80 PTo hP
box blade	Max. Cutting width	96 in. (2,438 mm) maximum or rated for 80 PTo hP w/fW a
rear blade	Max. Cutting width	180 in. (4,572 mm) maximum or rated for 80 PTo hP w/fW a
rotary Cutter	Max. Cutting width	not to exceed 180 in. (4,572 mm) pull type or lift or a 80 PTo hP rating
aerator	Max. width	96 in. (2,438 mm) maximum or rated for 80 PTo hP w/fW a
landscape rakes	Max. width	96 in. (2,438 mm) maximum or rated for 80 PTo hP w/fW a

NOTE : This is a sample of attachments commonly used. before purchasing or using any attachment on a **DAEDONG** product, please review the specifications to determine if it is a compatible product. Damages or failures due to improper use of compatibility issue will not be covered by warranty. If you have questions concerning product compatibility or warranty, please consult with your local **DAEDONG** Dealer.



DESCRIPTION OF OPERATING SYSTEM

EXTERIOR VIEW 4-3

SWITCH 4-5

MounTInG loCaTion	4-5
KEY sWITCh	4-6
CoMblnaTion sWITCh	4-7
hazarD laMP sWITCh	4-9
4WD sWITCh	4-9
PTo sETTInG sWITCh	4-10
DPf rEGEnEraTion sWITCh	4-12

INSTRUMENT PANEL..... 4-14

vIEW.....	4-14
fuEl GauGE	4-15
EnGInE CoolanT TEMPEraTurE GauGE	4-15
EnGInE oll PrEssurE W arnInG laMP ..	4-16
baTTEr Y CharGInG laMP	4-17
hEaD lIGHt hIGH bEaM laMP	4-17
Turn sIGnal laMP	4-17
GloW PluG laMP	4-18
ParKInG braKE laMP	4-18
PTo InDICaTor.....	4-18

4WD InDICaTor	4-19
braKE (onE sIDe) laMP	4-19
rEGEnEraTion WarnInG laMP	4-20
rEGEnEraTion unDEr WaY laMP	4-20
EnGInE ChECK W arnInG laMP	4-20
WaTEr In fuEl WarnInG laMP	4-22
CrulsE laMP (If EQUlPPED)	4-23
lInKED PEDal laMP	4-23
CrulsE PTo laMP	4-23
Error InDICaTor	4-24

OPERATING THE CONTROLS 4-25

Main shIfT lEvEr.....	4-27
ranGE GEar shIfT lEvEr	4-27
shuTTIE shIfT lEvEr	4-28
CluTCh PEDal	4-28
braKE PEDal	4-29
sTEErInG WhEEl aDjusTMENt	4-30
ParKInG braKE lEvEr	4-30
fooT ThroTTIE	4-31
hanD ThroTTIE lEvEr.....	4-32
lInKED PEDal lEvEr	4-32

4

4



DESCRIPTION OF OPERATING SYSTEM

DiffErEnTial loCK PEDal	4-33
sEaT aDjusTMEnT	4-34
PosiTion ConTrol IEvEr	4-36
DrafT ConTrol IEvEr.....	4-36
lIfTInG arM (loWEr lInK) sPEED ConTrol Knob.....	4-37
Double aCTInG IEvEr.....	4-37
7-Pln PoWEr ouTPuT soCKET (oP- Tion)	4-38

TIRES, WHEELS AND BALLAST 4-39

GEneral TirE InforMaTion	4-39
InflaTion PrEssurE	4-40
TrEaD.....	4-41
WhEEl TorQuE anD DirECTIon.....	4-41
aDDITional WEIGHt(oPTional)	4-43





ExTERIOR vIEW



- (1) Seat
- (2) Steering Wheel
- (3) Hood/Bonnet
- (4) Head Light
- (5) ROPS
- (6) Fender
- (7) Turn Signal Lamp
- (8) Rear View Mirror
- (9) Sun Canopy





- (1) Brake Lamp/Turn Signal Lamp
- (2) Top Link
- (3) PTO Shield
- (4) Crank Lifting Rod
- (5) Telescopic Sway bar
- (6) Draw Bar
- (7) Lower Link

TE7O429A



SWITCH mOUNTING LOCATION



- (1) *Tachometer*
- (2) *Combination Switch*
- (3) *Key Switch*
- (4) *Cruise Control Switch*
- (5) *Front Wheel Drive Switch*
- (6) *Hazard Lamp Switch*
- (7) *Beacpm Lamp Switch*
- (8) *PTO Select Switch (Auto <-> Manual)*
- (9) *DPF Regeneration Switch*
- (10) *PTO ON/OFF Switch*



KEY SWITCH



(1) Key Switch

() Off

() Manual Pre-Heat

() Start

() On(Auto Pre-Heat)

• () (a)

The position "a" indicates the "manual preheat". This position is a self-return type, so the key should be held there while pre-heating. The pre-heating indication lamp on the dash board will turn on at the same time. **Pre-heating more than 30 seconds consecutively can reduce the preheat system's life.**

• () (b)

When the key switch is in position "b", the engine and all electrical devices in the vehicle are turned off.

however flasher lights and turn signal lights can be operated along with their indication lamps on the dash board.

• () (C)

The position "C" indicates the "on" position. as soon as the key switch is turned to this position, the oil pressure warning lamp and battery charge warning lamp comes on (These turn off after the engine is started).

NOTE

- The pre-heating operation will automatically be activated in this position "C" (on). The automatic preheat operation is indicated by the glow plug indicator. Make sure to preheat the engine until the glow plug indicator goes off (approx. 9 seconds) in cold weather.

• () (D)

The position "E" indicates "start". In order to start the engine, depress the clutch pedal and turn the PTo switch off.

as soon as the engine is started, release the key then the key will return to the position "C".

⚠ CAUTION

- Stop the engine immediately if the oil pressure warning lamp does not go off after the engine is started. The engine may be severely damaged.
- If the battery charge warning lamp does not go off after the engine is started, check the electrical systems, such as the alternator, for damage. Continuing to use the engine under this condition can discharge the battery or damage other electrical devices.

📖 NOTE

- The ignition key is not directional and can be inserted in any direction. also, be careful not to leave the tractor unattended as the same key is used for all **KIOTI** tractors. It can be stolen.
- The horn, turn signal lamp, and hazard lamp can be operated without the key inserted.

COMBINATION SWITCH

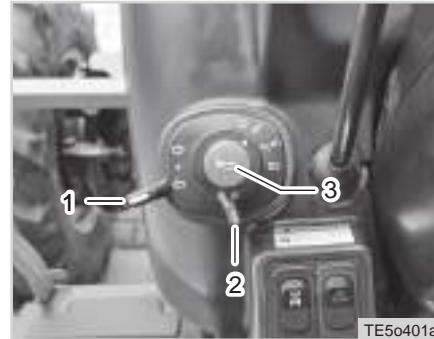

- (1) Turn Signal Light Switch
 (2) Head Light Switch
 (3) Horn Switch

The combination switch consists of the head light, turn signal light, and horn switches. Its function by its position is as follows:

- off : head light and tail light off
 ☰☉ : low beam and tail light on
 ☷☉ : high beam and tail light on
 ⇄ : Turn signal light on

HEAD LIGHT SWITCH

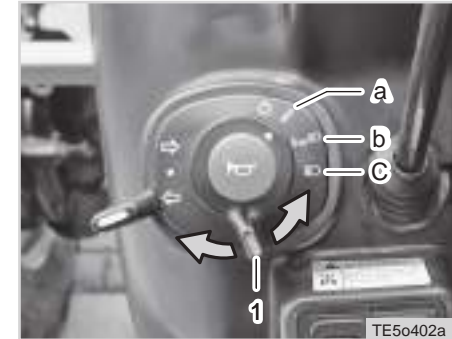

- (1) Head Light Switch
 (A) "OFF" (B) Low Beam "ON"
 (C) High Beam "ON"

The head light switch can be operated only while the key switch is turned to the "on" position. Turning the head light switch clockwise one click will illuminate the low beam head lights while turning it one more click will illuminate the high beam head lights.

⚠ WARNING

- *Driving with high beam head light disturbs the approaching vehicle's visibility for safe driving. Use the high beam head lights only if necessary.*

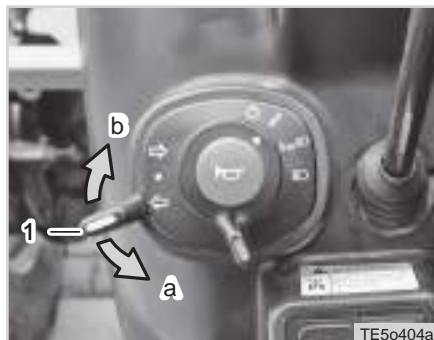
TURN SIGNAL LIGHT SWITCH

(1) Turn signal light switch
(A) Left turn (B) Right turn

The turn signal lights are used when turning the vehicle left or right. Pulling the lever down blinks the left turn signal light while pushing the lever up blinks the right turn signal light.

📖 NOTE

- The turn signal light lever is not the self-return type. Therefore, make sure to return the lever manually after turning the vehicle.
- The turn signal lamps can be operated without the key inserted.

HORN SWITCH

(1) Horn Switch

The horn switch can be operated without the key inserted. Pressing this switch sounds the horn.



HAZARD LAmP SWITCH

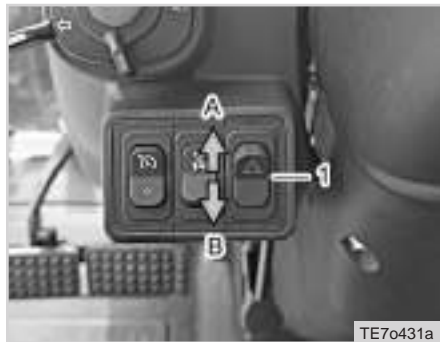

(1) Hazard Lamp Switch
(A) ON (B) OFF

This switch can be used to warn other vehicles when malfunction occurs in the tractor while driving on a public road. Pressing this switch up blinks the hazard lamp and returning it turns off the lamp. The turn signal lights cannot be operated while this switch is pressed up to operate the hazard lamps.

⚠ CAUTION

- If the hazard lamps are turned on for an extended period of time while the engine is stopped, the battery can be discharged. Therefore, use them only in emergency.
- The hazard lamp can be operated without the key inserted.

4WD SWITCH

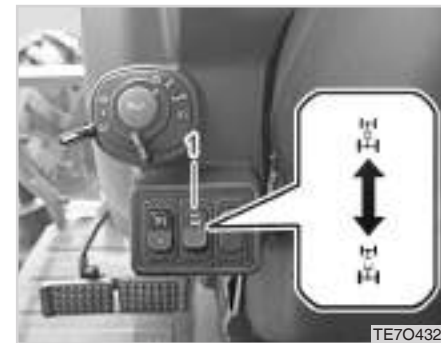

(1) Front Wheel Drive Switch
⚙ "Engaged" ⚙ "Disengaged"

use this switch to activate the 4WD mode. Pressing its upper portion activates the 4WD mode. Each mode is performed as follows.

The 4WD (4 Wheel Driving) is to increase traction by driving four wheels. It is hydraulically operated by a simple switch operation.

To engage the 4WD, press the switch up. To disengage it, return the switch.

The 4WD function can be used under the following conditions:

1. If high traction is needed in a humid area.
2. When towing a trailer or using a loader.
3. When working on a sandy surface.
4. When the tractor is pushed out by reaction from the implement during cultivating on a hard surface.
5. When cultivating a field or driving over a bank.

Switch position	Turning	Lamp
2WD	normal turning	lamp off
4WD	normal turning	4WD lamp on 

CAUTION

To avoid accident:

- Engage the switch only when the vehicle is stationary.
- While the 4WD is engaged, drive the vehicle with low speed as steering and braking characteristics may differ.
- It is possible to engage the 4WD during driving. However, you may hear noise or feel slight shift impact some at times in this case. For safe driving, engage the 4WD when the tractor is stationary.
- The 4WD should not be used on a paved road as tires can be worn faster.

PTO SETTING SWITCH REAR PTO SWITCH



(1) Auto-Manual Switch (2) PTO Switch

1. The tractor has a 540rpm speed position.
2. Electric/hydraulic engagement PTO shifting needs clutch operation. Press the clutch pedal down completely to stop the tractor movement and any PTO driven equipment movement before shifting the PTO gear shift lever.

 **CAUTION**

To avoid accident:

- **Disengage PTO, stop engine, and allow all rotating components to come to a complete stop before connecting, disconnecting, adjusting, or cleaning any PTO driven equipment**

PTO CLUTCH SWITCH

PTo operation is controlled by the auto/manual switch and the cut off switch.

1. PTo connected - auto

If the PTo clutch switch is turned to auTo position, when the attachment is raised to the set position by the position control lever, PTo is automatically cut off.

2. PTo connected - Manual

If the PTo clutch switch is turned to Manual position, PTo is operated regardless of the height of the attachment.

3. after setting the manual/auto switch to the desired setting, turn the PTo switch “on” or “off” as required to operate the PTo.

 **ImPORTANT**

- **To avoid shock loads to the PTO, reduce engine speed when engaging the PTO, then open the throttle to the recommended speed:**
- **To avoid damage to the transmission before turning the PTO on fully disengage the clutch.**

Engine rpm	PTO shaft	PTO rpm
2,600	6-spline	540

 **NOTE**

- There is a PTo-1 (540 rpm) indicator marked on the tachometer.

PTO SHIELD AND SHAFT CAP

TE7O434A

(1) PTO Shield

(2) PTO Shaft Cap

You should keep the PTO shield in place at all times and remember to replace the cap when the PTO shaft is not in use.

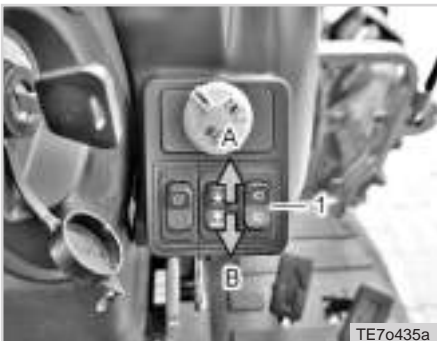
DPF REGENERATION SWITCH

TE7o435a

(1) DPF Regeneration Switch

(A) Activation

(B) Deactivation

ACTIVATION (UPPER PORTION OF SWITCH)

Perform the following instructions when the regeneration warning lamp comes on: (see page 4-18.)

1. Park the tractor on a flat surface.
2. Idle the engine.
3. Depress the brake pedals and stop the vehicle.
4. Put all shift levers into the neutral position.
5. run the engine for 3 to 4 minutes.

Then, press the activation portion of the regeneration switch for approx. 2 seconds.

NOTE

- The illumination timing of the regeneration process lamp may differ depending on the DPf temperature.

6. The regeneration warning lamp goes off and the regeneration process lamp blinks.

before resuming your work, wait for approx. 30 to 40 minutes until the regeneration process is completed.

DEACTIVATION (LOWER PORTION OF SWITCH)

Do not press the deactivation portion of the switch while the regeneration process is activated.

however, the switch can be set to the deactivation position to stop the regeneration process in emergency.

 **CAUTION**

To protect the catalyst filter, keep the followings:

- make sure to use only specified fuel.
- Keep the engine oil replacement schedule.
- Check the engine oil level frequently to keep it to the specified level.
- Avoid any unnecessary engine idling.
- Never stop the engine during driving.
- Never place the shift lever in the neutral position when driving downhill.
- Do not use any engine oil additive or fuel additive.
- Avoid driving with any warning lamp illuminated.
- Do not allow any flammable materials, such as dry grass and paper, to come near the catalyst filter while parked.

INSTRUMENT PANEL VIEW

symbols on the instrument panel come on when the key switch is turned to the "on" position.

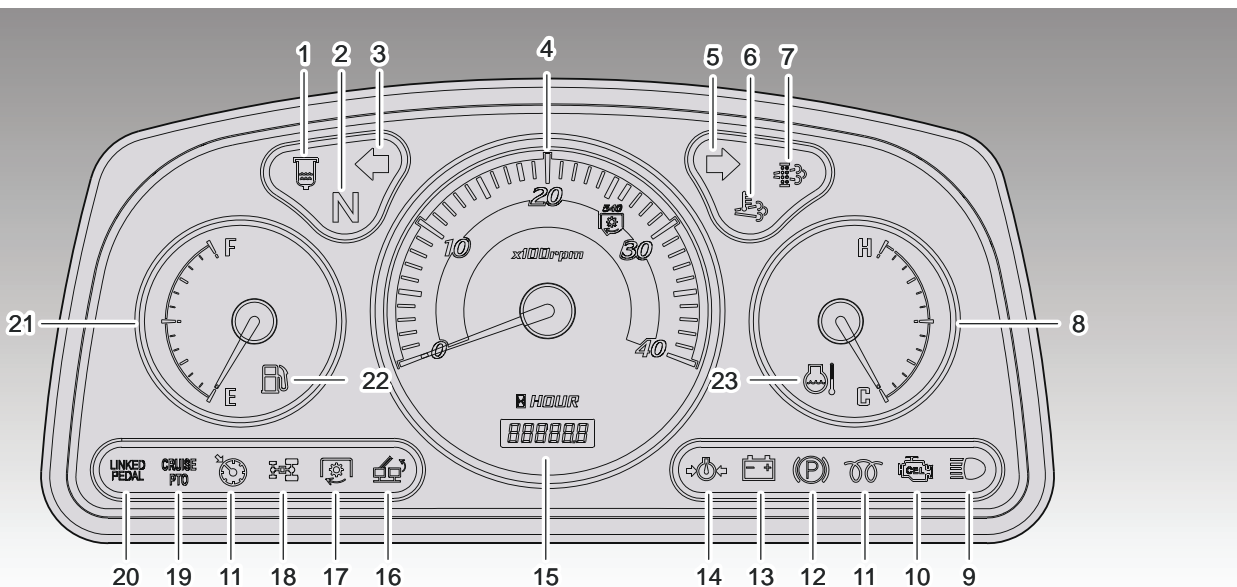

TE7O404A

- | | | | |
|------------------------------------|-----------------------------------|---------------------------------------|-----------------------------------|
| (1) Water Sensor Warning Lamp | (7) DPF Regeneration Warning Lamp | (13) Battery Charge Warning Lamp | (19) Cruise Indicator |
| (2) Neutral Indicator | (8) Coolant Temperature Gauge | (14) Engine Oil Pressure Warning Lamp | (20) Linked Pedal Indicator |
| (3) Turn Signal Light (LH) | (9) High Beam Indicator | (15) Hour Meter | (21) Fuel Gauge |
| (4) Tachometer | (10) Engine Check Warning Lamp | (16) Brake (One Side) Lamp | (22) Low Fuel Level Warning Lamp |
| (5) Turn Signal Light (RH) | (11) Glow Plug Indicator | (17) P.T.O Indicator | (23) Engine Overheat Warning Lamp |
| (6) DPF Regeneration Underway Lamp | (12) Parking Brake Indicator | (18) 4WD Engaged Indicator | |

FUEL GAUGE

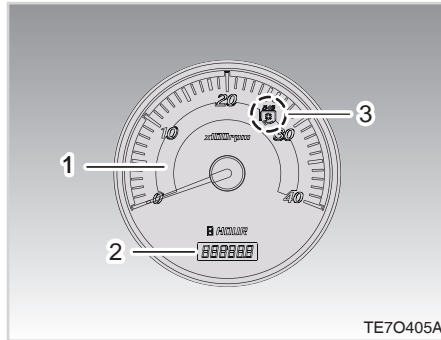

"E" EMPTY

"F" FULL

NOTE

- Make sure to use only ultra low sulfur oil for automobiles as the engine can be damaged if unqualified fuel is used.
- use fuel for winter season in cold weather to start the engine easier.
- The gauge needle can move on a hill as fuel slopes in the tank.

ENGINE COOLANT TEMPERATURE GAUGE

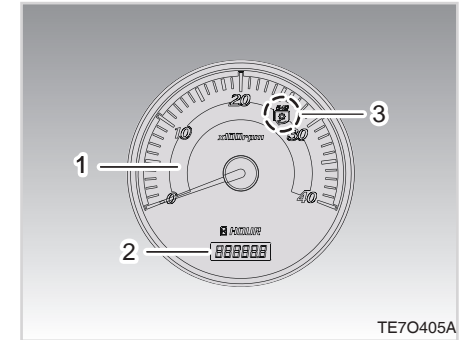

"C" COLD

"H" HOT

4

This indicates the remaining fuel level after the key switch is turned to the "on" position.

- **F** : Fuel is fully filled.
- **E** : replenish the fuel tank.

NOTE

- Make sure to use only genuine fuel as the engine can be damaged if unqualified fuel is used.

This gauge indicates the coolant temperature after the key switch is turned to the "on" position.

- **C** : Coolant is cold.
- **H** : Coolant is hot.

The range marked in "H" in the figure indicates the abnormal engine temperature. reduce the engine rpm immediately.

ENGINE OIL PRESSURE WARNING LAMP

CAUTION

- make sure to control the work load so that the needle is not in the red zone.
- If the needle stays in the red zone, do not stop the engine immediately. Instead, reduce the work load to cool down the engine before stopping the engine.
- make sure to keep the front grill clean so that air is sucked through it freely for fast cooling.

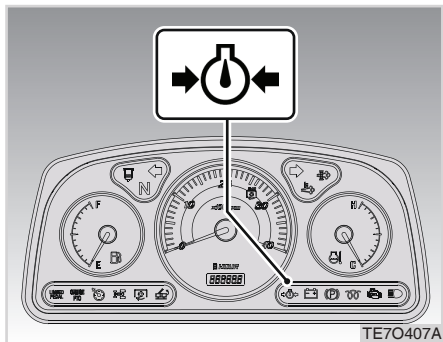

CAUTION

- If the oil level is below the specified range, the engine can seize.
- The engine can be severely damaged if driving or operating the tractor with the engine oil warning lamp ON.

This lamp comes on when the engine oil pressure or oil level is low.

If this lamp comes on while driving, stop the engine immediately and check the engine oil level.

If this lamp comes on even with the specified engine oil level, have the tractor checked by your local **KIOTI** dealer.

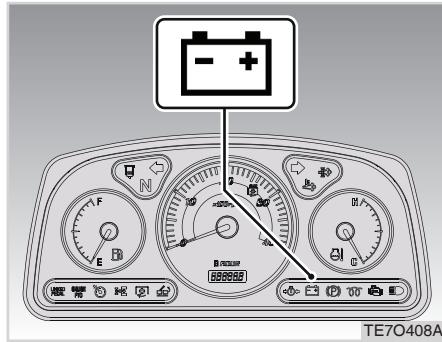
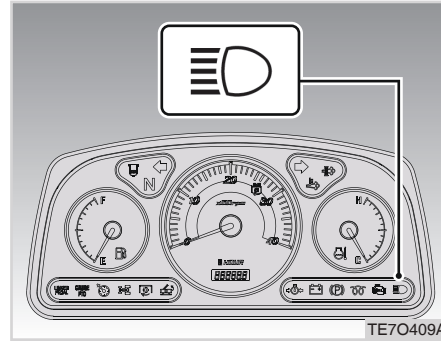
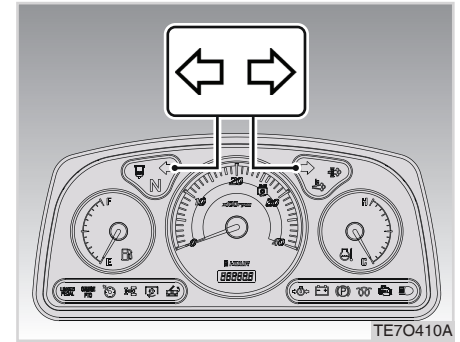
BATTERY CHARGING LAMP**HEAD LIGHT HIGH BEAM LAMP****TURN SIGNAL LAMP**

4

This lamp is turned on when the starting switch is turned on before starting the engine but turned off after starting the engine.

CAUTION

- If this warning lamp comes on while driving, the charging system, such as the alternator, is malfunctioning. Therefore, turn off all electrical devices and have the tractor checked by your local KIOTI Dealer.

This lamp comes on in blue when the high beam head light is switched on. Driving with high beam head light disturbs an approaching vehicle's visibility. For safe driving, use the high beam head light only if necessary.

operating the turn signal lamp switch up and down turns on the corresponding lamp in green.

GLOW PLUG LAMP

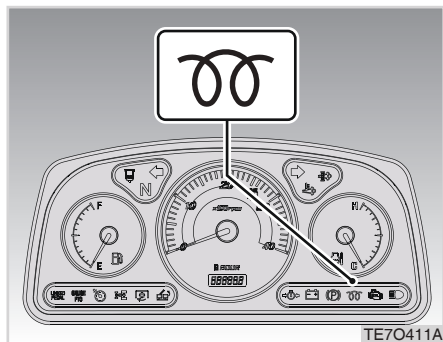

This indicates the operating condition of the preheat system. When the key switch is turned to the "on" position, this lamp comes on. It is recommended to start the engine as soon as this lamp goes off for best starting performance. This lamp may not turn on if the engine is warm. In this case, the engine can be started without the preheat operation.

PARKING BRAKE LAMP

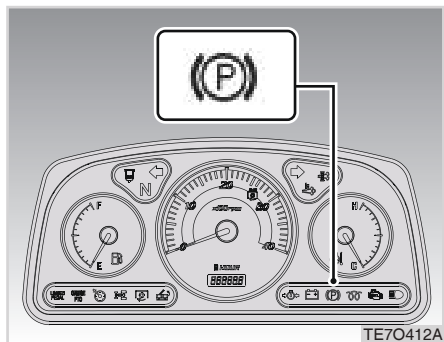

When the parking brake is actuated, the lamp lights on.

CAUTION

- If this lamp is ON even with the parking brake released, have the tractor checked by your local KIOTI dealer.

PTO INDICATOR

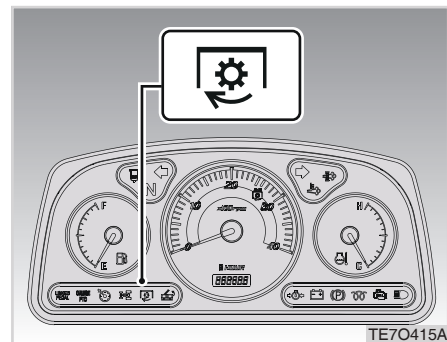

This indicator shows the PTO engagement condition. When the PTO is engaged, this indicator comes on. When the PTO clutch is disengaged, this indicator goes off.

CAUTION

- Set the PTO switch to the "OFF" position in order to start the engine.

4WD INDICATOR

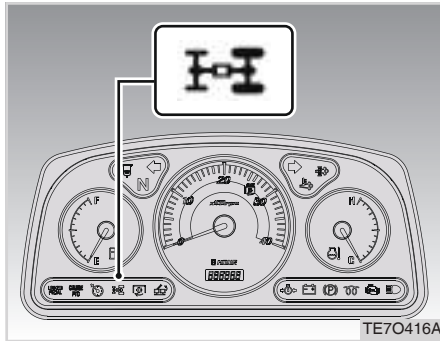

This comes on to indicate 4WD engagement.

CAUTION

- The durability of the axle can be deteriorated if only one brake pedal is depressed during the 4WD is activated.

BRAKE (ONE SIDE) LAMP

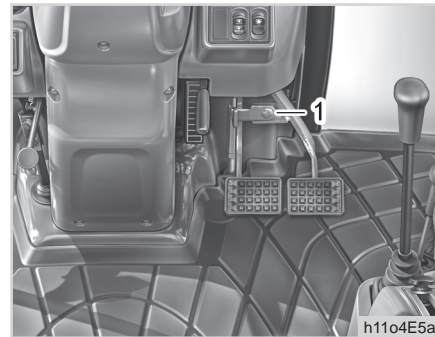
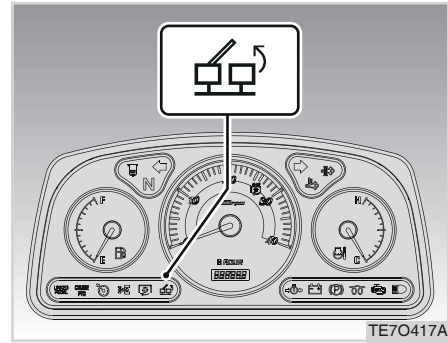

(1) Brake Pedal Lock (Both Sides)

This lamp indicates the operating status of the brake (one side). This

comes on when the brake lock for two brake pedals is unlocked.

IMPORTANT

- When driving on a public road or at a high speed, never use only one brake pedal. The tractor can roll over.
- While the brake (one side) lamp is not illuminated, the brake pedals are not interlocked and only one brake pedal can be depressed accidentally. make sure to set the pedal lock to the "Lock" position in a normal condition.

REGENERATION WARNING LAMP

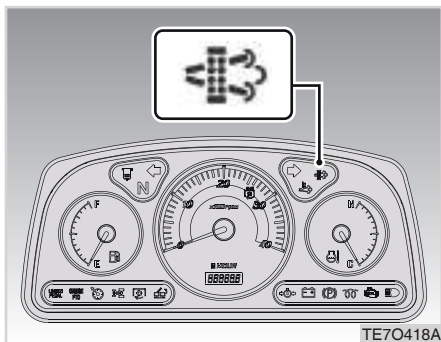

If carbon is accumulated in the exhaust catalytic filter, the warning lamp comes on or blinks.

If this lamp comes on, push down the "regeneration" button. (refer to the page 4-17)

REGENERATION UNDERWAY LAMP

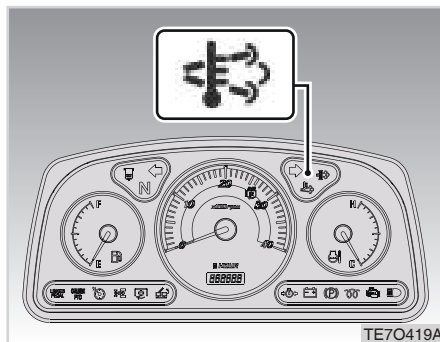

This lamp on when it is on regeneration in DPf.

⚠ WARNING

- *When on regeneration, Don't touch the part of DPf because it is very hot around DPf.*

ENGINE CHECK WARNING LAMP

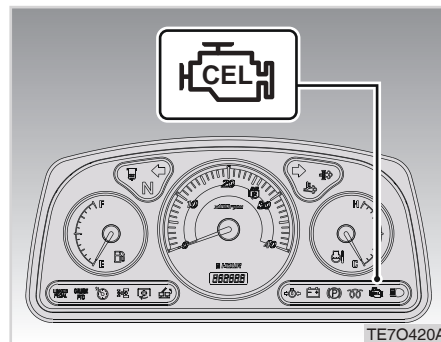

This comes on when any major electric device or engine fuel system is malfunctioning.

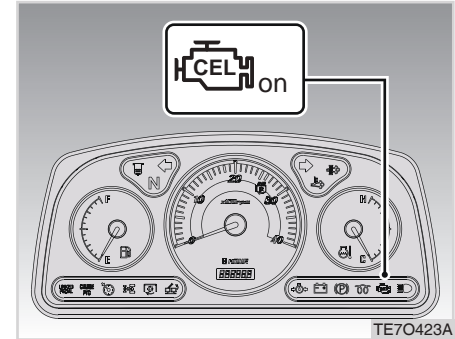
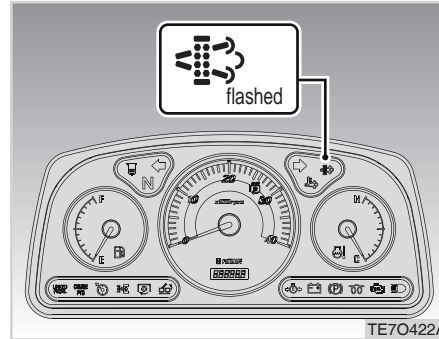
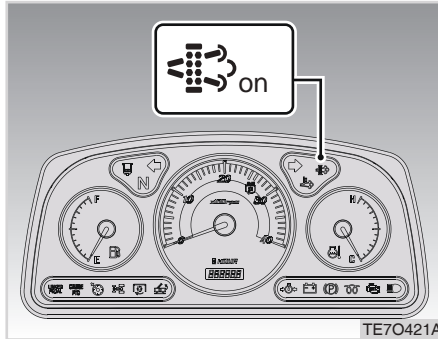
DPF REGENERATION WARNING Lamp

4

1. stage 1 warning lamp for DPf clogging

: DPf soot loading level 120% - 160%

Manual regeneration required

Engine rPM limit (below 2,200 rpm)

If this warning lamp comes on, make sure to press the "regeneration" button. (see page 4-8)

2. stage 2 warning lamp for DPf clogging

: DPf soot loading level 160% - 200%

Manual regeneration required

Engine rPM limit (below 2,200 rpm)

If the DPf is not regenerated in the stage 1 warning state, the warning lamp blinks. In this state, make sure to perform DPf regeneration process. (see page 4-8)

3. stage 3 warning lamp for DPf clogging

: DPf soot loading level 200% or higher

Passive regeneration prohibited

Engine rPM limit (below 1,500 rpm)

If the DPf is still not regenerated even in this state, the Check engine lamp comes on and the DPf needs to be replaced.

⚠ WARNING

- *In the warning level 3 (CEL lamp ON), both manual and automatic regeneration processes cannot be performed.*
- *When the DPF warning lamp comes on, make sure to perform the manual regeneration as the active regeneration cannot be performed.*
- *Enabling condition for manual regeneration*
 - *Clutch engaged*
 - *Brake ON*
 - *Engine rpm Idle state*
- *If any of the above conditions is not met during regeneration, the regeneration mode is deactivated.*

⚠ WARNING

- *Other general operation cannot be performed during the manual regeneration process. During regeneration, the engine speed is maintained*
 - *1st: Before mode: 30 ~ 700 sec. at 1,500 rpm*
 - *2nd: Regen mode: 1,500 sec. at 2,600 rpm*
 - *3rd: After mode: 180 sec. at 1,600 rpm*

WATER IN FUEL WARNING LAMP

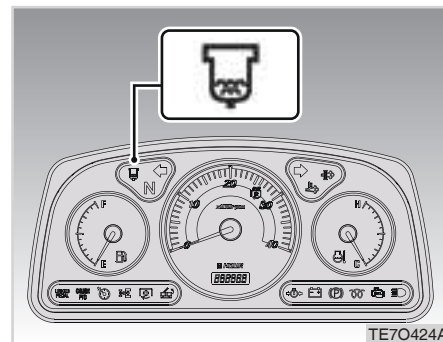

The warning buzzer sounds when (approx. 45 cc) of water is accumulated in the fuel filter. In this case, stop the engine immediately and drain water from the fuel filter.

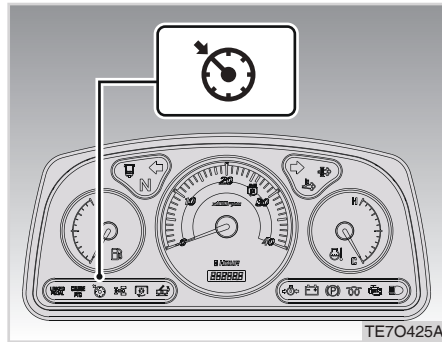
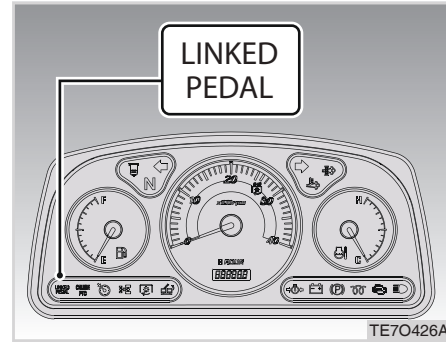
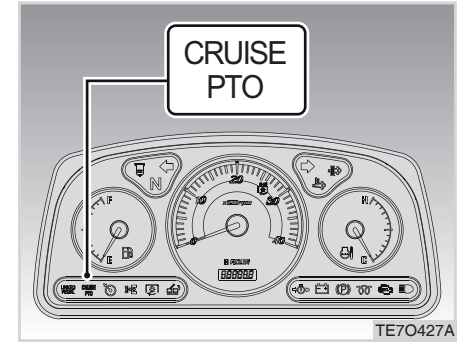
CRUISE LAmP (IF EQUIPPED)**LINKED PEDAL LAmP****CRUISE PTO LAmP**

4

1. operating condition

Turn on the cruise switch during driving. Then, the cruise lamp comes on.

2. Deactivation condition

When pressing the brake pedal, turning off the cruise switch, the cruise lamp goes off.

The lamp comes on when the synchronization switch or lever is connected.

The switch is used to set the PTO rpm. With the PTO cruise button set in the on position, pressing the SET (-) button turns on this lamp.

ERROR INDICATOR

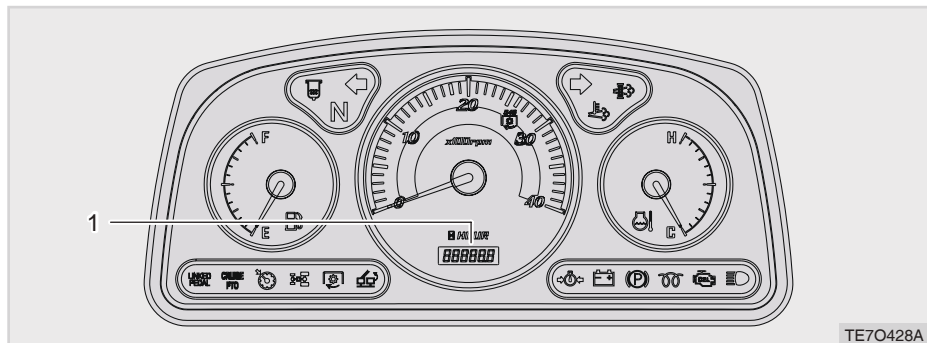

TE7O428A

(1) Display

You can see the Error code below on the ICD window for hour meter. When You found these on the ICD, please contact with **KIOTI** dealer.

NO.	DISPLAY	DESCRIPTION
1	Err-001	no signal at TaCho Input
2	Err-002	no signal at W ater Temp
3	Err-006	no signal at GloW laMP Input
4	Err-007	no signal at PTo CruIsE laMP
5	Err-008	no signal at W ater In fuEl Input
6	Err-009	no signal at hour Input



NOTE

- some error codes may not displayed depending on the model.

DIAGNOSTIC TROUBLE CODE(DTC)

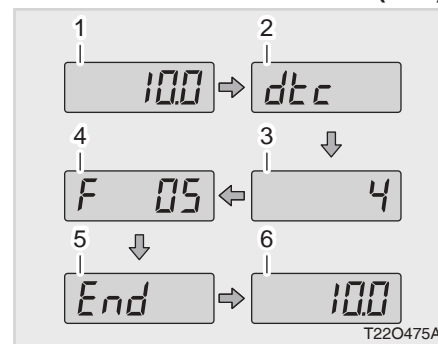

T22O475A

- (1) Total run hours (2) dtc
 (3) SPN (Suspect Parameter Number)
 (4) Fmi (Failure Mode Indicator)
 (5) End (6) Total run hours

If an error code occurs on the engine, the information of (1) to (6) is displayed on the hourmeter of the ICD window at an interval of 1 second.



WARNING

- **When a DTC occurs, make note of operating conditions and information alert indicators. Contact your KIOTI dealer for service assistance.**



OPERATING THE CONTROLS

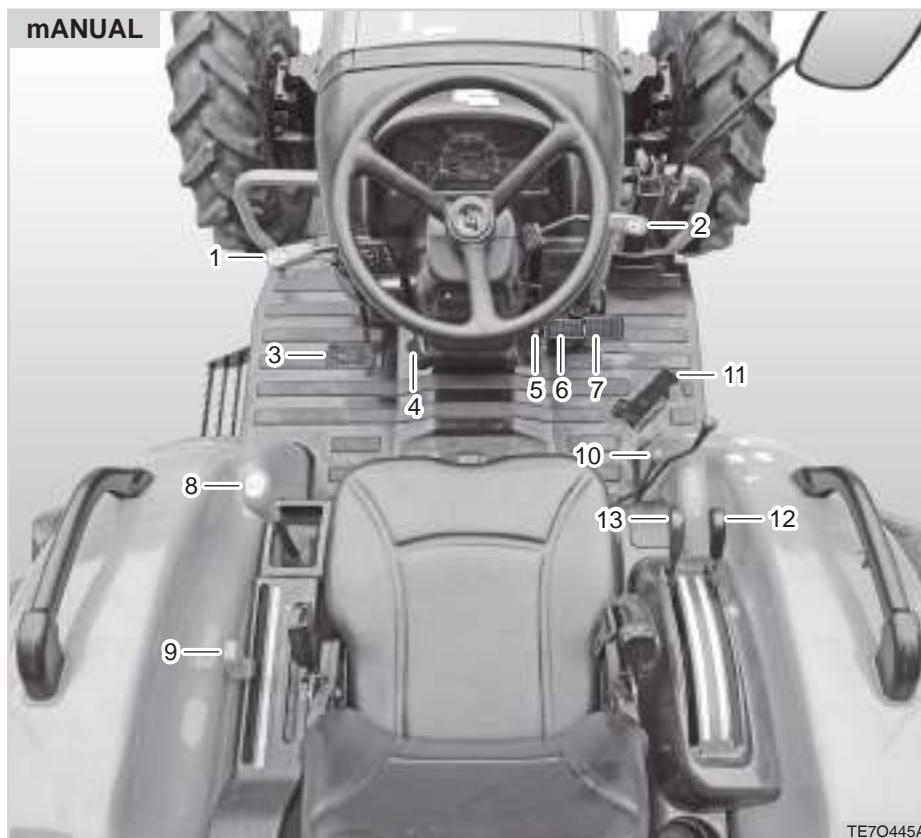

- (1) Shuttle Shift Lever
- (2) Hand Throttle Lever
- (3) Clutch Pedal
- (4) Tilt Steering Pedal
- (5) Parking Brake Lock Lever
- (6) Brake Pedal (L)
- (7) Brake Pedal (R)
- (8) Main Gear Shift Lever
- (9) Range Gear Shift Lever
- (10) Double Acting Lever
- (11) Foot Throttle
- (12) Lift Position Control Lever
- (13) Draft Control Lever

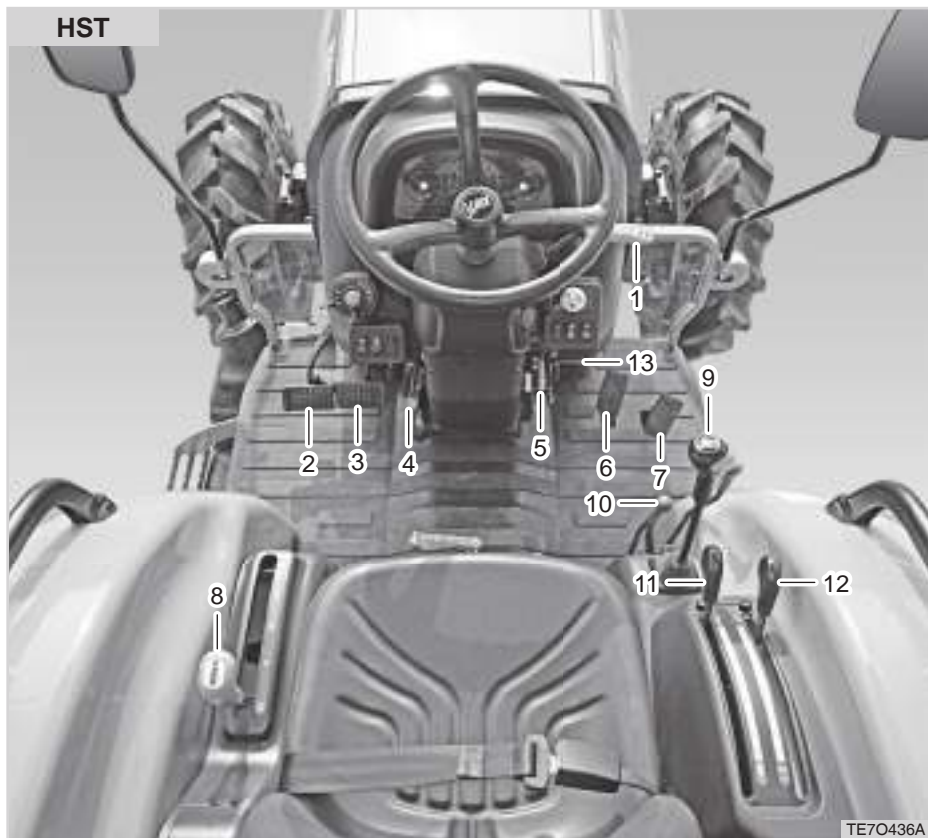

- (1) Hand Throttle Lever
- (2) Brake Pedal (L)
- (3) Brake Pedal (R)
- (4) Tilt Steering Pedal
- (5) Parking Brake Lock Lever
- (6) HST Forward Pedal
- (7) HST Reverse Pedal
- (8) Range Gear Shift Lever
- (9) Joystick Lever
- (10) Double Acting Lever(A,B)
- (11) Draft Control Lever
- (12) Lift Position Control Lever
- (13) Linked Pedal Lever

mAIn SHIFT LEvER

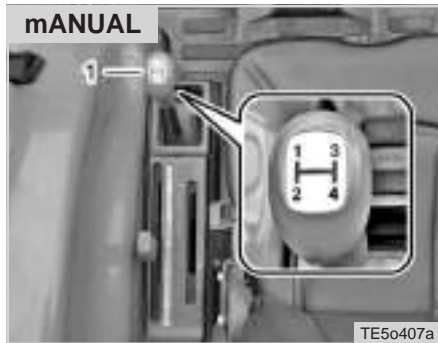

(1) Main Shift Lever

four speeds can be selected by moving this main shift lever in "h" shaped path. You can shift into this lever from the 1st to 4th gears even when the tractor body is moving by disengaging the clutch during driving as these gears are synchromeshed.

In total, 12 forward driving speeds and 12 reverse driving speeds are provided by combination of the main shift lever (4 speeds), range shift lever (3 speeds), shuttle shift lever.

RANGE GEAR SHIFT LEvER



(1) Range Shift Lever
 (⚙️) High Speed (⚙️) Mid Speed
 (⚙️) Low Speed (N) Neutral

high, mid and low speeds can be selected by the range shift lever. follow the instruction below if a problem occurs during shifting this lever:

1. Put the range shift lever into the neutral position.
2. Depress the pedal slightly to prevent the gears in the transmission from rotating.
3. shift the range shift lever into the desired position with the brake pedal and front/rear driving pedals depressed.

⚠️ CAUTION

- make sure to shift the range gear shift lever with the clutch pedal depressed and the tractor stationary (manual Type).
- Never put the range shift lever into the high speed position during driving backward as it is dangerous to drive at a high speed.
- The tractor is not braked by depressing the brake pedal without depressing the clutch pedal at a low speed as rotational force of the axle has a major effect at a low speed. **Therefore, disengage the clutch before depressing the brake pedal to stop the tractor. (manual Type)**

SHUTTLE SHIFT LEVER



(1) Shuttle Shift Lever
(F) Forward (R) Reverse
(N) Neutral

This lever is used to select forward or reverse driving. The lever can be shifted while the tractor is moving with the clutch disengaged as these gears are synchromesh. Shifting this lever frequently can deteriorate the transmission's life and durability.

Put this lever into the n position (neutral) when the tractor is not driven.

⚠ CAUTION

- Reduce the speed before moving this lever since it is very dangerous to switch the driving direction at a high speed.

CLUTCH PEDAL

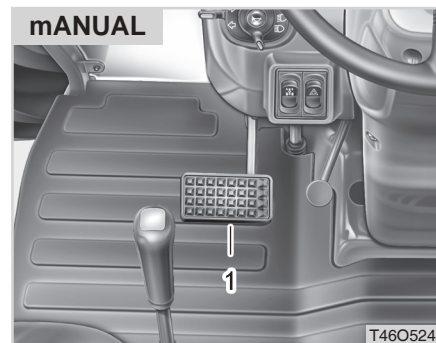

(1) Clutch Pedal

Make sure to depress the clutch pedal to its end. To start off smoothly, put the main and range shift levers into the proper positions and release the clutch pedal slowly.

⊕ ImPORTANT

- Never put your foot onto the clutch pedal during driving. The clutch disc can be worn pre-maturely.
- Be sure to depress the clutch pedal fully when shifting. Otherwise, the shift gear can be broken.

BRAKE PEDAL

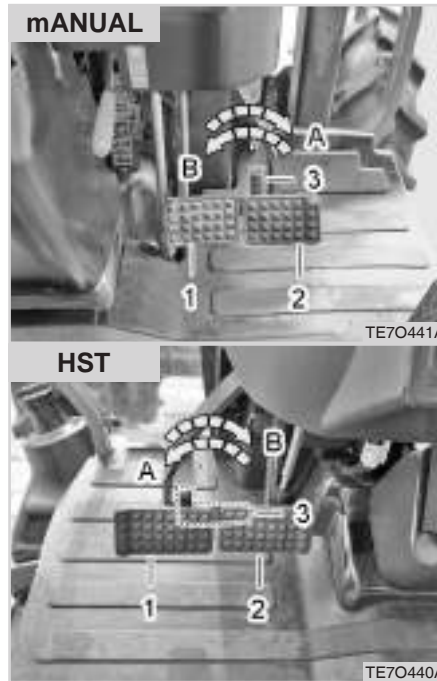

(1) Brake Pedal (LH) (2) Brake Pedal (RH)
 (3) Interlock
 (A) Engage (B) Disengage

1. Make sure to link the left and right brake pedals as shown in the figure while driving on a road.

The tractor can roll over if depressing only one brake pedal at a high speed.

2. When turning sharply on a field, disengage the left and right brake pedals to use one brake pedal. unlock the brake lock, and then turn the steering wheel while depressing the brake pedal on the turning side.

3. Depressing only one brake pedal is not much effective while the 4WD is activated. (Effective in case of 2WD)

⚠ WARNING

- *make sure to interlock the brake pedals as an accident, such as rollover or impact, can occur during driving and entering/exiting field.*
- *Avoid using only one of the brakes in the 4WD mode since it can reduce the life of the axle. Use the quick turn function rather than one side brake in the 4WD mode. Also, it can be efficient to use one side brake in the quick turn mode.*

⚠ CAUTION

- **Be sure to disengage the clutch before depressing the brake pedal to stop the tractor.**

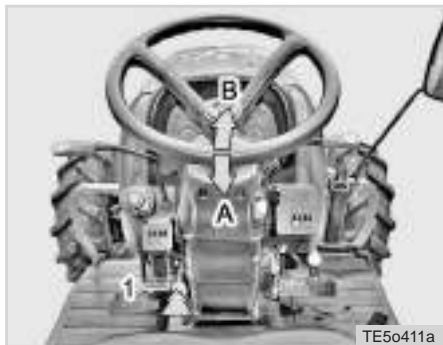
STEERING WHEEL ADJUSTMENT

(1) Steering Wheel Tilt Pedal
(A) Lowering (B) Lifting

The angle of the steering wheel can be adjusted for the driver's comfort. hold the steering wheel with both hands, depress the tilt pedal lightly and then adjust the position of the steering wheel as desired.

⚠ WARNING

- **Do not adjust the tilt steering while driving.**

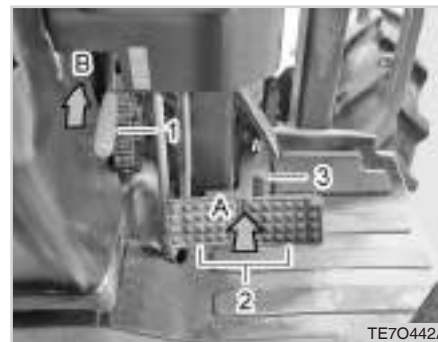
PARKING BRAKE LEVER

(1) Parking Brake Lever (2) Brake Pedals
(3) Interlock (4) Block
(A) Depressing (B) Push Down

To stop the tractor, depress the brake pedal and pull the lever up to apply the parking brake.

The parking brake is automatically released by depressing and then releasing the brake pedal.

⚠ CAUTION

- **If the vehicle is driven with the parking brake partially or completely engaged, it may cause early wear of the brake disc.**

FOOT THROTTLE

WARNING

To avoid possible injury, death or loss of property from a machine runaway:

- *With the engine off, the tractor may move unexpectedly regardless of the gear shift position.*
 - *Before leaving the tractor, firmly apply the parking brake to prevent machine runaway.*
- ※ *Only H-shuttle model.*

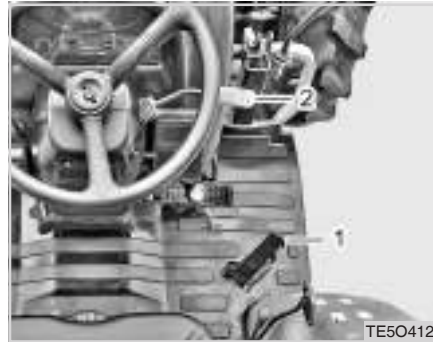

(1) Foot Throttle (2) Hand Throttle Lever

The foot throttle is mainly used during driving on a road while the hand throttle lever is mainly used while working on a field.

ImPORTANT

- **For heavy load job, such as front end loader operation, use low or medium speed of the range shift lever.**



NOTE

- If the ignition key is turned on or the engine is started while depressing the forward or reverse driving pedal, the Cal lamp turns on and forward or reverse driving is disabled for safety. This restriction is automatically canceled when keeping the forward or reverse driving pedal released for 1 second. However, if the lamp is still illuminated, contact **KIOTI** dealer.

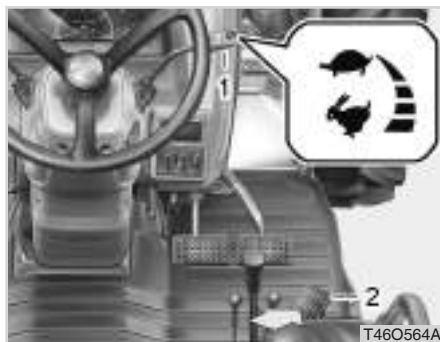
HAND THROTTLE LEVER



(1) Hand Throttle Lever (2)Foot Throttle
 INCREASE  DECREASE

The hand throttle lever is to control the engine rpm. The engine accelerates to its full speed by pulling the hand throttle lever ( position) completely out while pushing the lever ( position) decelerates the engine.

The hand throttle lever is mainly used while working on a field.

CAUTION

- Using the accelerator lever during driving can lead to an accident as it becomes hard to decelerate the tractor rapidly.

LINKED PEDAL LEVER



(1) Linked Pedal Lever
 (A) ON (B) OFF

When placing the linked pedal lever in the “on” position, the engine rpm is synchronized with the hST driving pedal.

- 1) Depressing the hST forward/reverse driving pedal: Increase engine rPM.
- 2) releasing the hST forward/reverse driving pedal: Decrease engine rPM.

DIFFERENTIAL LOCK PEDAL

⚠ CAUTION

In abnormal driving condition, such as rapid acceleration or deceleration, is occurred by operating the HST pedal, not by other functions such as the load match, speed synchronization and cruise control, follow the following steps immediately.

- 1) Release the driving pedal.
 - 2) Depress the brake pedal to its end.
 - 3) Turn the ignition switch to the "OFF" position.
- Stop the tractor by performing the steps above.



- (1) Differential Lock Pedal
(A) Release to "Disengage"
(B) Depress to "Engage"

The differential lock is to secure the differential system and keep the wheel rotation on both sides the same in order to enhance the traction of the rear axle.

Depressing the pedal engages the differential lock while releasing the pedal disengages the differential lock.

use this system under the following conditions:

1. When any wheel slips and the tractor does not move in the field.
2. When it is hard to break away from a paddy field.

CAUTION

- The differential lock should be engaged only while the driving clutch is engaged. If the differential lock pedal does not move when depressing it, try to depress it again after releasing it.
- When engaging the differential lock, reduce the engine speed. After engaging it, accelerate the tractor.
- make sure to set the steering wheel in the straight ahead position while the differential lock is in use. Otherwise, the differential system can be damaged.

SEAT ADJUSTMENT SEAT SLIDING



(1) Seat Adjustment Lever

To adjust the seat position, pull the lever (1) to upward under the front of the seat, slide the seat to the desired position, and then release the lever.

Make sure that the seat is firmly fixed by moving it gently after adjustment.

CAUTION

- Do not put a hand between the seat and the slides when adjusting the seat position. You can be injured unexpectedly.

WARNING

- *Never Leave the driver's seat while the engine running.*
- *Before leaving the seat, be sure to turn off any implements which are equipped with rotating blades such as rotary tiller, rotary cutter, mid/rear mower, snow blower, etc. and turn off the engine.*



CUSHION STRENGTH ADJUSTmENT



(1) Cushion Adjustment Lever

The seat cushion can be adjusted according to the weight of the driver. Turning the cushion adjustment lever counterclockwise to the 50 kg position makes the cushion lighter, and turning the lever clockwise to the 120 kg position makes the cushion heavier.

SEAT BELT



(1) Seat Belt

The seat belt is self-retracting type. Make sure to fasten the seat belt before driving.

WARNING

- ***Be extra careful not to let any part of your body under the tractor or an implement when lowering an implement.***

WARNING

- ***Always fasten the seat belt when the tractor has ROPS properly. Otherwise, never wear the seat belt.***
- ***make sure that the seat belt is not twisted. It cannot work properly, leading to a dangerous situation.***

POSITION CONTROL LEVER



(1) Position Control Lever
(A) Lifting

The position control lever is used to keep the plowing depth constant during work.

The implement attached to the lifting arm can be lowered by pushing the lever while the implement is raised by pulling the lever.

In order to limit the lowering height of implements, use the lock bolt (2) to limit the operating range of the lever.

for detailed information, refer to "Initial operation" in Chapter 5.

WARNING

- *make sure that there is nobody or not obstacle around the three-point linkage before controlling position lever.*

DRAFT CONTROL LEVER

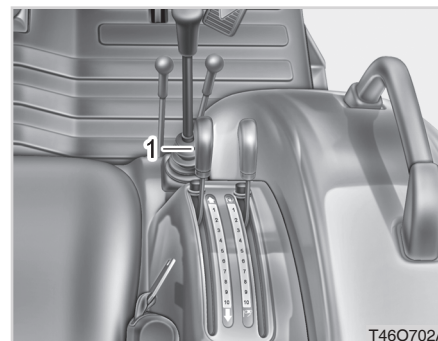

(1) Draft Control Lever

The draft function can be used for the plow which is installed to the lower link. (lifting arm)



LIFTING ARm (LOWER LINK) SPEED CONTROL KNOB

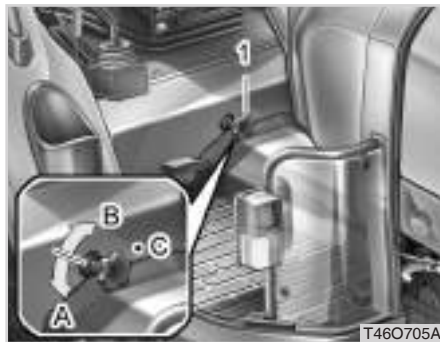

T46O705A

- (1) Lowering Speed Control Knob
- (A) Fast
- (B) Slow
- (C) Lock

Turning the knob counterclockwise increases the lowering speed while turning it clockwise decreases the lowering speed. also, turning it clockwise to its end can fix the implement to a certain position.

NOTE

- This knob does not control the lifting speed of the lifting arm.

DOUBLE ACTING LEVER

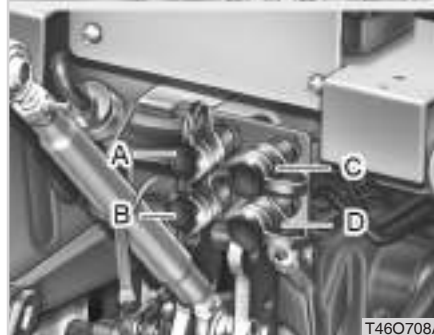

T46O708A

- (1) Double Acting Lever 1
- (2) Double Acting Lever 2
- (A) A PORT
- (B) B PORT
- (C) C PORT
- (D) D PORT

Pressure \Rightarrow returning \leftarrow

Port		Push		Pull
lever1	a	In \leftarrow		out \Rightarrow
	b	out \Rightarrow		In \leftarrow
lever2	C	In \leftarrow		out \Rightarrow
	D	out \Rightarrow		In \leftarrow

Port	Coupler Size
a, b, C, D	PT 1/2"

4

basically a remote valve, which is a detent type, is attached.

In a normal range you could lift up and down an implement with shifting and holding the lever.

When you let go your hold, the lever would return to neutral automatically.

however, in case you shift the lever in a detent range, hydraulic pressure is still on. so, if you want to release it out of the detent range, you need to shift it again to the neutral.



⊕ ImPORTANT

- Do not hold the lever in the “pull” or “push” position once the remote cylinder has reached the end of the stroke, as this will cause oil to flow through the relief valve.
- To enlarge the front loader output, when using the hydraulic system of the tractor, do not operate the boom and the bucket cylinder simultaneously

7-PIN POWER OUTPUT SOCKET (OPTION)



TE70443A

(1) Power Connector

The 7-pin socket is installed on the rear left side of the tractor.

This supplies power to the brake lamps, turn signal lamps, and position lamps of the trailer.

NO	CIRCUIT	COLOR OF WIRE
1	Earth	l
2	Tail, number plate	br
3	left turn signal	G
4	stop	r
5	right turn signal	Y
6	sidelight	b
7	spare	l

⚠ WARNING

- *When driving on a road with an implement which has exterior lamps, such as a trailer, make sure to turn on those lamps by connecting them to the 7-pin socket in order to prevent an accident.*
- *make sure to check for proper operation after connecting the 7-pin socket to the trailer. It may not operate depending on the trailer specifications. Consult your local KIOTI Dealer for this issue.*

TIRES, WHEELS AND BALLAST

GENERAL TIRE INFORMATION

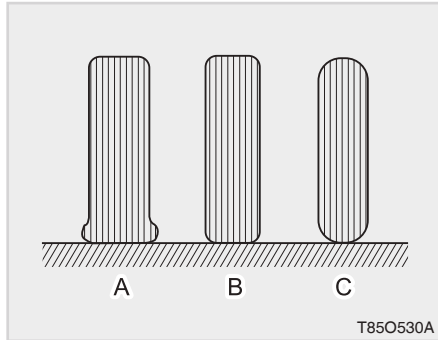

(A) *Insufficient*
(C) *Excessive*

(B) *Standard*

Though the tire pressure is factory-set to the prescribed level, it naturally drops slowly in the course of time. Thus, check it everyday and inflate as necessary.

⚠ WARNING

- *Do not use tires larger or smaller than specified.*

⚠ WARNING

- *Do not disassemble or assemble the tire. If it is necessary to disassemble/assemble the tire, let a qualified service person perform the work.*



4

⚠ WARNING

- *Use caution when inflating or checking air pressure.*

INFLATION PRESSURE

Always maintain the proper tire inflation pressure. Make sure the tire pressure does not exceed the pressure recommended in the manual.

Type	Class	Tire Sizes	Inflation Pressure
agricultural Tire	front	9.5-16	2.2 kg/cm ² 216 Kpa 31 psi
		8-16	2.4 kg/cm ² 235kPa 34psi
	rear	13.6-26	1.6 kg/cm ² 157 Kpa
		13.6-28	23 psi



NOTE

- Keep the front tire pressure to maximum when using the front end loader or front suitcase weights.
- If tires with a different size from the ones already in use are installed, contact the **KIOTI** dealer for the front/rear wheel speed ratio. Improper front/rear wheel speed ratio can result in excessive wear of the tires.

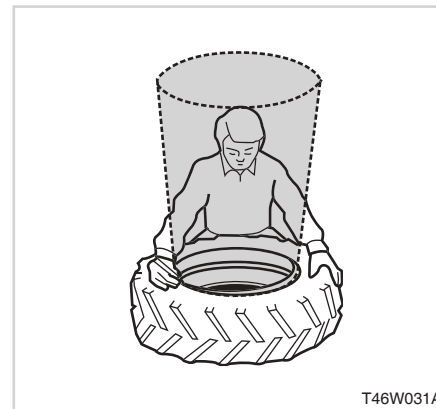

T46W031A

⚠ WARNING

- **Do not weld or apply heat to the tire rim or disc. The tire can explode due to the rapidly increased pressure in the tire.**
- **Check tires for inflation pressure, damage, deformation, and excessive wear on lug and damage of rim and disc. Also check if wheel bolts, rim bolts, and nuts are loose.**



TREAD

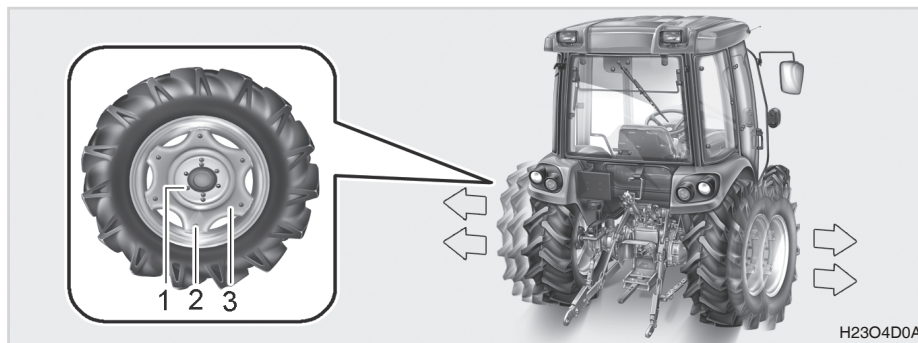

(1) Bolt

(2) Rim Bolt

(3) Disc

WHEEL TORQUE AND DIRECTION FRONT/REAR WHEEL INSTALLATION PATTERN

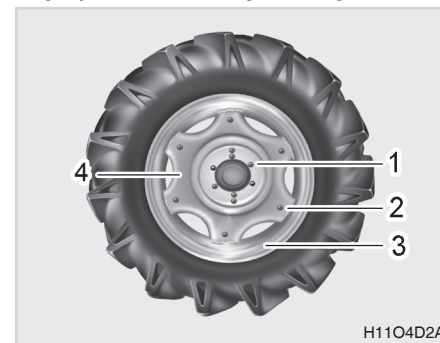

(1) Wheel Nut
(3) Rim

(2) Rim Bolt
(4) Disc



When working on a field where crops are linearly aligned, the tread should be adjusted so that the tires do not cross over the crops.

It is also necessary to widen wheel tread to decrease danger when working on slopes or hills, or when doing trailer work, etc.

WARNING

Never operate tractor with a loose rim, wheel, or axle.

- **Always tighten nuts or bolts to the specified torque.**
- **Make sure to frequently check that all these parts are firmly tightened.**
- **make sure to perform inspection daily.**

The front and rear axle tread width are adjustable by changing the installation of the tire (together with rim) to the disk, to suit the type or condition of work. ref to “TrEaD” in prior page.



FRONT AND REAR WHEEL BOLT AND NUT TORQUE

Tightening torque of wheel bolt and nut	front	196.1~225.6 n.m (20.0~23.0 kgf.m)
	rear	196.1~225.6 n.m (20.0~23.0 kgf.m)

Rim BOLT AND NUT TORQUE

Tightening torque of rim bolt and nut	front & rear	259.9~304 n·m (26.5~31 kgf.m)
---------------------------------------	--------------	-------------------------------

 WARNING

- *Use tires approved by KIOTI only.*
- *Assemble the tire as shown in the figure.*
- *Contact your local KIOTI Dealer if it is necessary to change the tire specification or installation method.*

**WHEEL INSTALLATION DIRECTION**

for agricultural tires, make sure to install them with their arrow marks on their side pointing to the front driving direction.

The tire is correctly installed if the tread mark "v" on the ground is shown correctly, not up side down, while the tractor is moving forward.

**ADDITIONAL WEIGHT(OPTIONAL)
ADDITIONAL FRONT WEIGHT**

(1) Additional Front Weight

If the front tires are heavily loaded and it becomes hard to steer the tractor, the tires can be worn faster and the durability of the front axle can be deteriorated.

4

If the loader is not installed, attach a weight to the front frame of the tractor as a safety measure.

If a heavy implement is installed at the rear or when towing a heavy trailer, the front wheels may be lifted. add sufficient weight to keep steer ability and to prevent rollover.

If sufficient weight, such as front loader, is applied to the front wheels, remove the extra front weight.

COMPONENTS FOR ADDITIONAL FRONT WEIGHT

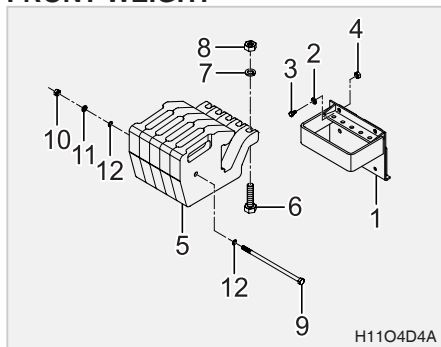

- | | |
|--------------------|-----------------------|
| (1) Front Bracket | (7) Spring Washer |
| (2) Spring Washer | (8) Nut |
| (3) Bolt | (9) Front Weight Bolt |
| (4) Nut | (10) Nut |
| (5) Balance Weight | (11) Spring Washer |
| (6) Bolt | (12) Plain Washer |

When installing or removing a weight, always check the tire inflation pressure and adjust it as necessary.

The front weights are available at the **KIOTI** Dealer. For required number of weights, consult your local **KIOTI** Dealer.

max. load 17 kg x 6 Pieces (224 lbs)

⚠ CAUTION

- **Additional weight might be needed for transporting heavy implements.**
- **Reduce the speed regardless of additional weight when driving on a bumpy or rough road with the implement lifted. The tractor can roll over.**

⊕ ImPORTANT

- **Attach only required amount of weight.**
- **The life of the axle or wheel can be shortened.**

ADDITIONAL REAR WEIGHT

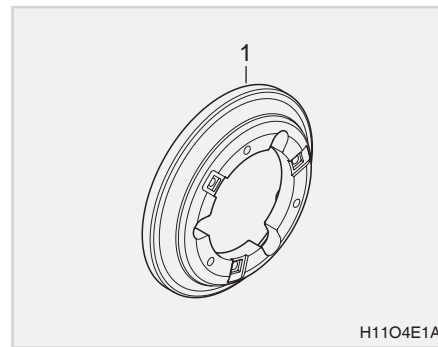

(1) Rear Weight

The rear weight is used to maximize the draft of the tractor by increasing the grip of the rear wheels when using a heavy trailer or plow.

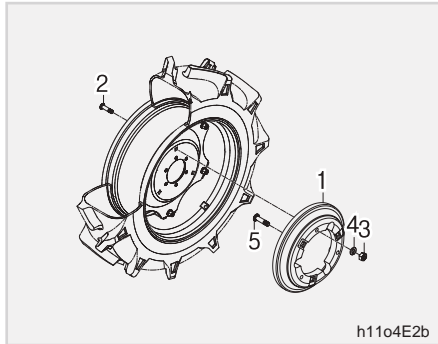

- (1) Rear Weight (2) Weight Bolt
 (3) Nut (4) Spring Washer
 (5) Bolt

for detailed information on installation, contact your local **KIOTI** Dealer.

max. load 25kg x 5 Pieces (275lbs)

⊕ ImPORTANT

- **Attach only required amount of weight.**
- **Unnecessary weight can result in poor braking performance, rapid wear of the brake disc, shortened axle life, and increase in fuel consumption.**

ADDITIONAL LIQUID TYPE WEIGHT

It is possible to inject water and calcium solution into the tire to use it as a ballast.

📖 NOTE

- The liquid injection should be performed only by a qualified service personnel.
- for detailed information, contact your local **KIOTI** Dealer.

If one liter of water is mixed with 0.4 kg of calcium, this liquid does not freeze down at -49 °f (-45 °C).

for a tire without a tube, fill it with water and calcium solution at least to the valve stem level (75%) with the valve stem.

If the tire without a tube is not filled with water and calcium solution sufficiently, a part of the ream is exposed, resulting in corrosion.

For a tire with a tube, fill it up to 90% of its level.

📖 NOTE

- If the liquid ballast is used, inflate the tire 0.14 bar (2 psi) more than the specified pressure. This is to compensate for the ventilation symptom which occurs while the tire is moving.



mEmO





OPERATION

PRE-OPERATION.....5-2

INITIAL OPERATION.....5-3

OPERATING THE ENGINE5-3

sTarTInG ThE EnGInE5-3

sToPPInG ThE EnGInE5-8

WarMInG uP5-9

juMP sTarTInG5-10

OPERATING THE TRACTOR..... 5-11

hoW T o DrIvE 5-11

hoW To foLD ThE roPs5-14

hoW T o ralsE ThE roPs T o uPrIGHT
PosITIon5-15

ParKInG 5-16

TurnInG5-18

DrIvInG on sloPE..... 5-18

ThE CauTlons WhEn CoMInG In anD
ouT of P avED roaD 5-19

PrECauTlons WhIE DrIvInG on ThE
roaD 5-20

loaDInG InTo anD unloaDInG ouT
of ThE TruCK 5-20

PrECauTlons WhEn usInG PoWER
sTEErInG 5-21

3-PoInT hITCh ConTrol sYsTEM..... 5-23

ExTErIor hYDrAuIlC ConTrol sYs-
TEM5-27

5

5



PRE-OPERATION

It is a good practice to know the condition of your tractor before you start it. You should do routine check before each use.

CAUTION

- **Stop the tractor on level ground, stop the engine, and apply the parking brake before checking or repairing it.**
- **Refer to "Daily inspection" in the section "Service" for fuel replenishment.**
- **Read information titled as "Danger", "Warning", and "Caution" thoroughly for the safe operation.**

CHECK ITEM

- Walk around inspection to look for loose or missing hardware.
- Check the engine oil level.
- Check the transmission oil level.
- Check the coolant level.
- Clean the grill and radiator screen.
- Check the air cleaner filter.
- Check the brake pedal.
- Check all dash gauges and indicators.
- Check head lights, tail lights, and all working lights.
- Check accessible wiring harness for any damage.
- Check the seat belt and **ROPS** for damage.
- Check all danger and warning labels.
- Check fuel level.
- Check all danger and warning decals.
- visually check tire inflation and wheel bolt tightening.

for detailed information, refer to "Maintenance interval" in chapter 6.

INITIAL OPERATION

Driving a new tractor at a high speed or load can damage its overall durability.

Make sure to run the tractor at the proper work load and speed for the initial operation of 10 to 20 hours.

TIPS FOR BREAKING-IN

1. start the engine and idle the engine at a low speed for 3 to 4 minutes in advance.
2. Increase the idling time in cold weather.
3. Do not drive the tractor at the maximum speed on a road.
4. never apply excessive load during work.
5. Idle the engine at a low speed for 2 to 3 minutes before stopping it.

OPERATING THE ENGINE STARTING THE ENGINE

WARNING

To avoid accidents:

- *Be sure to read and understand the warning and caution decals on the tractor thoroughly.*
- *Run the engine only in a well-ventilated area, or you can be suffocated by exhaust gas.*
- *Never start the engine unless you are on the driver's seat. The tractor can abruptly start off, resulting in an injury or accident.*

ImPORTANT

- Using an additive so the engine will start more easily can damage the engine. And it will not be covered by warranty.
- Never try to start the engine for over 10 seconds consecutively to protect the start motor and battery from damage.

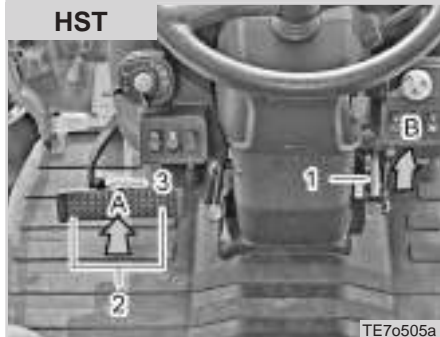
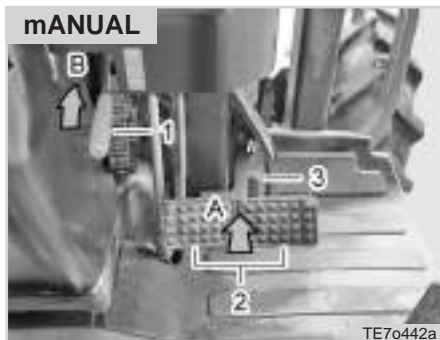

(1) Parking Brake Lever (2) Brake Pedal
 (3) Connecting Hook
 (A) Depressing (B) Pressing Down

1. Make sure there is no obstacle around the tractor.
2. Make sure the parking brake is set
 - (1) To set the parking brake;
 - 1) Interlock the brake pedals
 - 2) Depress the brake pedals
 - 3) latch the brake pedals with the parking brake lever. (Check that the parking brake lamp on the gauge board illuminates)
 - (2) To release the parking brake press the brake pedals again.



(1) Auto-Manual Switch (2) PTO Switch

3. Press the PTO switch to the “off” position.

⊕ ImPORTANT

- make sure that the brake pedals are fully depressed before pulling the parking brake lever up.

📖 NOTE

- When the parking brake is engaged, the parking brake lamp on the instrument cluster illuminates. When releasing it, the parking brake lamp is turned off.

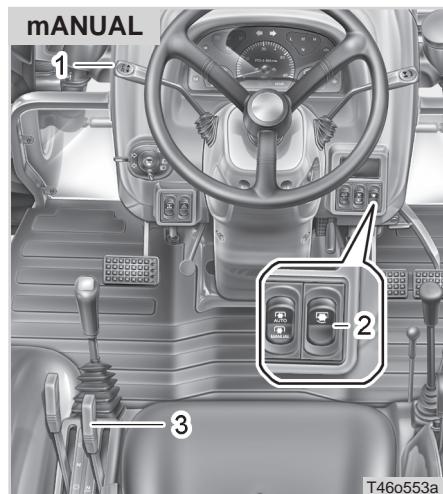

- (1) Forward/Reverse Lever
- (2) PTO Switch
- (3) Range Gear Shift Lever (Hi-Mid-Lo)

4. set the main, range and shuttle shift levers in the neutral position.



- (1) Position Control Lever
- (A) Down

5. lower the attachment by pushing the position control lever toward.

⊕ ImPORTANT

- make sure that no one is around the implement or behind the tractor.

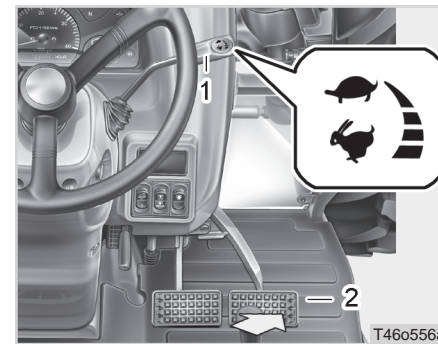

- (1) Hand Throttle Lever
- : Increase
- : Decrease

6. set the hand throttle lever into the neutral position.

⊕ ImPORTANT

- It cannot be started while the shuttle lever or PTO is engaged.



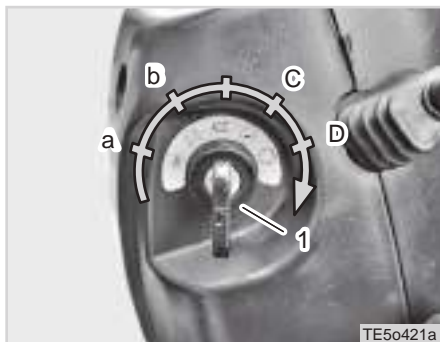

(1) Key Switch

-  : Off  : Manual Pre-Heat
 : Start  : On (Auto Pre-Heat)

8. Insert the key into the key switch and turn it "on". Maintain it until the preheat lamp is turned off. (approx. 8 sec)

⊕ ImPORTANT

- **Start Condition: Operator on the seat + Depressing Clutch pedal. (Shuttle lever, PTO and mid PTO levers should be in neutral position)**

OPERATING PRINCIPLE OF PREHEAT SYSTEM

The glow plug lamp comes on for 8 seconds and then goes off when the key switch is turned to the "on" position.

The engine should be started within 5 seconds after the glow plug lamp goes off. After the engine is started, post-heat is performed for 15 seconds with the key switch in the "on" position.

The preheat/after-heat function and glow plug lamp do not operate when the coolant temperature is 30°C (86°F) or higher. In this case, the engine can be started without the preheat operation.

* The post-heating is a function to keep the preheating function activated for approx. 15 seconds after the engine is started in order to enhance the engine combustion performance and reduce harmful emissions right after engine start.

⚠ WARNING

- **Never operate the start motor for 10 consecutive seconds as it consumes a lot of power. If the engine cannot be started within 10 seconds, wait for 30 seconds and try again.**
- **When trying to start the engine again, make sure that the fly-wheel is stopped in advance.**

9. When the engine is started, release the key. Then, the key is automatically turned back to the "on" position.

⚠ WARNING

- **Do not turn the key switch to the "Start" position while the engine is running.**

10. Warm up the engine for 3 to 4 minutes (10 minutes in winter) after releasing the clutch pedal.

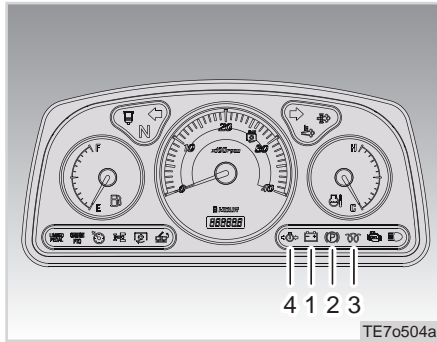

TE7o504a

- (1) Electrical Charge (2) Parking Brake
 (3) Glow Plug Indicator
 (4) Engine Oil Pressure

11. Check to see that all the warning lamps on the instrument cluster turn "off". If any lamp remains on, immediately stop the engine and determine the cause.

CHECKING CHECK LAMPS

1. If the oil pressure warning lamp (2) does not go off in 4 to 5 seconds after the engine is properly started, stop the engine immediately and check the engine oil level. If the engine oil level is proper, contact your local **KIOTI** Dealer.

! WARNING

- ***The engine can be severely damaged if it is run with the oil pressure warning lamp ON.***

2. If the charge warning lamp (3) does not go off in 4 to 5 seconds after the engine is properly started, it means that the battery is not being charged. have the charging system, such as the battery and alternator, serviced.

3. refer to "Instrument panel" in chapter 4 for detailed information about other indicators and lamps.

! WARNING

- ***If driving the tractor for an extended period of time with the charge warning lamp ON, the battery can be discharged and the tractor's electrical system can be damaged.***

STOPPING THE ENGINE

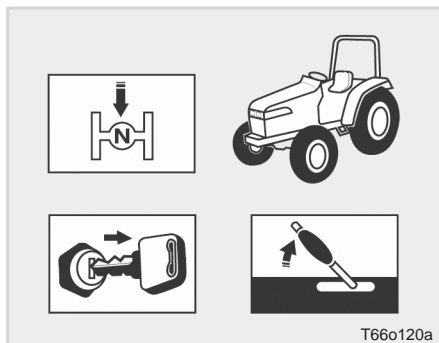

1. Make sure to reduce the engine rpm before stopping the engine.
2. Depress the clutch pedal and put all shift levers in the neutral position.
3. run the engine at the idle speed for approx. 2 to 3 minutes, and then turn the key switch to the "off" position to stop the engine.
4. remove the ignition key.

⚠ WARNING

- *Never touch the muffler or hot covers until they are cooled down after running the engine or driving the tractor.*

⊕ Important

- Turn off all the electrical devices and remove the ignition key before leaving the tractor.
- Also, be careful not to lose the ignition key as the keys used for all KIOTI tractors are the same in shape.
- The horn, turn signal lamp and hazard lamp can be operated without the key inserted. However, using these components without the engine started can discharge the battery.

⊕ Important

- This vehicle is equipped with a turbocharged engine. Avoid high RPM, abrupt acceleration and sudden start immediately after starting the engine. Also, idle the engine for approx. 2 minutes before driving.
- Also, before stopping the engine, idle the engine for approx. 2 to 3 minutes.
- The engine and turbocharger can be damaged prematurely unless idling the engine for a certain period right after it is started and right before it is stopped.



WARmING UP

It is recommended always to warm up the engine before driving in order to maintain the durability of the engine. before warming up the engine, make sure that each part in the engine is properly lubricated and each hydraulic part is in a perfect condition in order to prevent malfunction in the engine as well as the hydraulic system.

HOW TO WARm UP ENGINE

1. start the engine and run it at a low speed and without load for approx. 3 to 4 minutes.
2. In cold weather, increase the warming up time to 10 minutes.
3. If it is very cold, warm up the engine for approx. 15 minutes.
4. The engine throttle can be open for 50 % in order to shorten the warming up time.
5. The engine is sufficiently warmed up when the temperature gauge on the instrument panel indicates 1/4 of the normal temperature range, regardless of the warming-up time.
6. Do not increase the work load rapidly after starting work.
7. run the engine without load for approx. 2 to 3 minutes before stopping the engine after work.

WARNING

- *Warming up the engine excessively increases fuel consumption and affects the durability of the tractor negatively.*
- *Never warm up the engine and leave the tractor for an extended period of time. It can cause fire and an accident.*

JUmP STARTING



(1) Dead Battery (2) Jumper Cables
(3) Helper Battery

If the battery is discharged and the engine cannot be started, it is possible to start the engine by connecting the discharged battery to a battery from another tractor or other extra battery.

1. Check that the voltage of the discharged battery is same as the voltage of the other tractor or vehicle for jump start. (Specification for this tractor: 12 v)
2. Check the length of the jump cable and position another tractor near the tractor with the discharged battery. Then, put all the shift levers in the neutral position, apply the parking brake, and stop the engine.
3. Wear protective glasses and gloves and open the hoods of both tractors. remove the battery terminal cover as necessary.
4. Connect the alligator clips on both ends of the red positive cable to the positive terminals of both batteries.
5. Connect one clip of the black negative cable to the negative terminal of the normal battery and the other clip to the tractor body with the discharged battery. Make sure to connect the clip to the body part without paint.
6. start the engine of the tractor with the normal battery.
7. start the engine of the tractor with the discharged battery.
8. Disconnect the black cable from the negative battery terminals of both of the tractors.
9. Disconnect the red cable.
10. run the engine for at least 30 minutes to charge the discharged battery.
11. If the battery is discharged again, replace it or check the charging system, such as the alternator.

OPERATING THE TRACTOR

HOW TO DRIVE



- (1) Seat (2) Seat Back Adjustment Lever
 (3) Seat Adjustment Lever (Cushion Weight)
 (4) Seat Height Adjustment Lever
 (5) Seat Adjustment Lever (Sliding)

1. adjust the seat and fasten the seat belt.

⚠ WARNING

- **Check if the seat is securely locked after the seat adjustment.**
- **Do not adjust the seat while driving. The seat may move suddenly causing the loss of control of the tractor.**



- (1) Seat Belt

2. Wear the seat belt.

⚠ WARNING

- **Always wear the seat belt when cap is installed.**
- **If the seat belt is worn across the abdomen or waist, not the hips, an injury can occur in case of an accident or impact.**
- **Do not wear the seat belt if the ROPS is not installed or folded.**

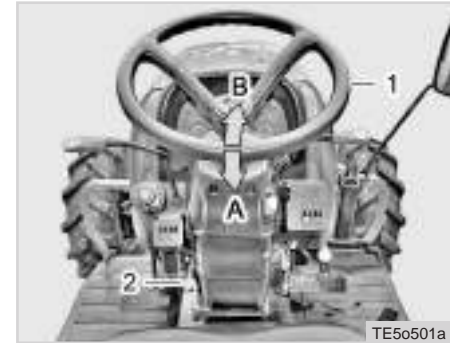

- (1) Steering wheel (2) Tilt Pedal
 (A) Lowering (B) Lifting

3. adjust the steering wheel according to the driver's comfort.

⚠ WARNING

- **Do not adjust the tilt angle of steering wheel while driving. You could lose the handle of your tractor, causing an accident.**

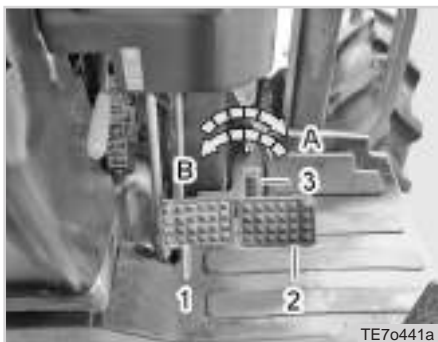

TE7o441a

- (1) Brake Pedal (LH) (2) Brake Pedal (RH)
 (3) Interlock
 (A) Engage (B) Disengage

4. Make sure the brake pedal of the left and right side is engaged.

⚠ WARNING

- *If depressing only one brake pedal at a high speed, the tractor can lose its balance and be off the track.*



T46o523a

- (1) Position Control Lever
 (A) Lifting

5. Pull the position control lever backward to raise the attachment.

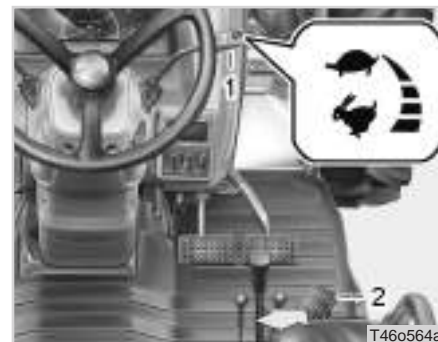

T46o564a

- (1) Hand Throttle Lever (2) Foot Throttle
 ⬅ INCREASE ➡ DECREASE

6. Increase slowly the engine rPM from idle speed to medium speed.

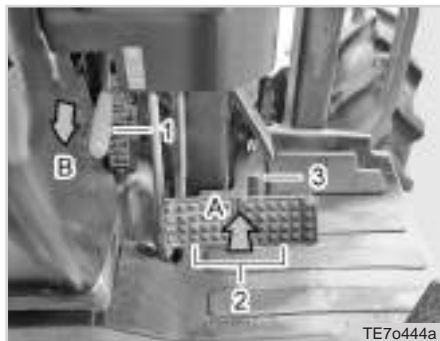

(1) Parking Brake Lever (2) Brake Pedals
(3) Interlock
(A) Depressing (B) Push Down

7. release the parking brake.

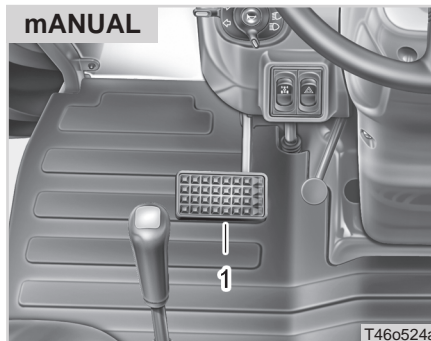

(1) Clutch Pedal

8. Depress the clutch pedal fully.

 **CAUTION**

To avoid accidents:

- **Do not release the clutch pedal abruptly. The tractor may start off abruptly, resulting in roll over.**

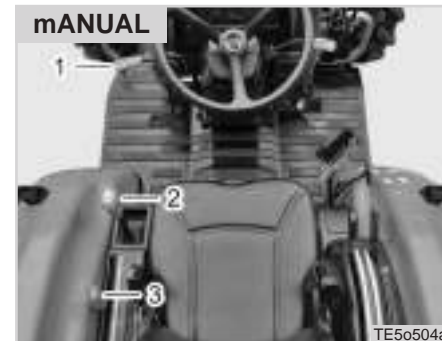

(1) Shuttle Lever (2) Main Shift Lever
(3) Range Shift Lever

9. Change the main shift, and shuttle lever to the position you want.
10. The tractor starts to move if you take away the clutch pedal slowly.



HOW TO FOLD THE ROPS

⚠ CAUTION

- Never put a foot on the clutch pedal during driving. The clutch disc can be rapidly worn.
- make sure to operate the clutch fast when disengaging it and slowly when engaging it.
- Do not change the tractor speed abruptly for safe driving.
- When driving on a slope or loading or unloading the tractor to a transporting vehicle, reduce the speed in advance so that there is no need to shift the gear in the middle of the slope. Also, do not put your hand on the shift lever while driving on a slope. The tractor may roll down the slope due to the disengaged gear which is very dangerous.



- (1) Grip Bolt (2) Set Pin
(3) Clip Pin

1. remove the clip pin and set pin.

⚠ CAUTION

- You should always stop the engine, remove the key and set the parking brake before raising or folding the ROPS.
- Always perform such tasks from a safe and stable position at the rear of the tractor.

⚠ CAUTION

- It is very dangerous to drive with the ROPS folded. Fold the ROPS only when there is absolutely no possibility for roll over. If the situation changes, raise the ROPS upright immediately.



HOW TO RAISE THE ROPS TO UPRIGHT POSITION



(1) ROPS

2. I oosen the grip bolt and fold the roPs.

CAUTION

To avoid accidents:

- Hold the ROPS tightly with both hands and fold the ROPS slowly and carefully.

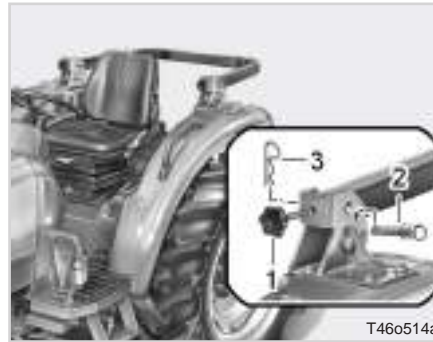

(1) Grip Bolt
(3) Clip Pin

(2) Set Pin

3. align pin holes, insert set pin, and secure them with the clip pin.

CAUTION

To avoid accidents:

- Fix the mounting bolt firmly and secure the frame with the knock bolt.



(1) ROPS

1. remove both the grip bolt, clip pin and set pin.
2. raise roPs to the upright position.

CAUTION

To avoid accidents:

- The ROPS must be raised slowly and carefully.



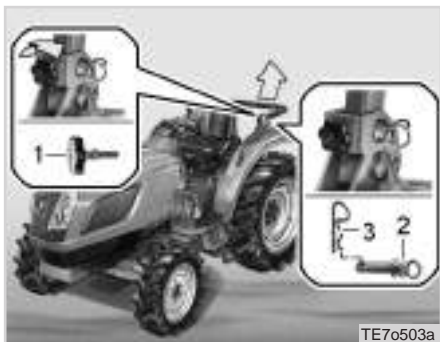

(1) Grip Bolt
(2) Set Pin
(3) Clip Pin

3. align pin holes, insert set pin and secure them with the clip pin.
4. fix the roPs with the grip bolt.

⚠ CAUTION

To avoid accidents:

- **make sure that pins are properly installed and secured.**

⊕ ImPORTANT

- **ROPS (Roll Over Protective Structure), sun canopy or cabin are not a FOPS (Falling Object Protective Structure). It never can protect the riders against falling objects. Avoid driving the vehicle into a dangerous area such as falling rocks zone. Otherwise, it may lead to a serious injury.**

PARKING

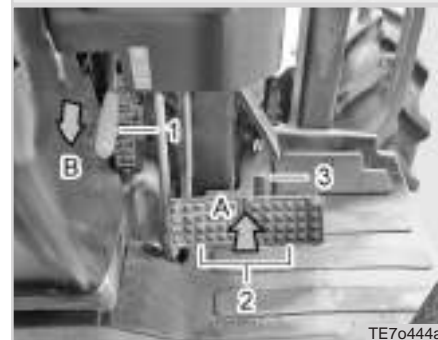

(1) Parking Brake Lever (2) Brake Pedals
(3) Interlock (4) Block
(A) Depressing (B) Push Down



1. This tractor is not equipped with a separate parking brake. however uses the brake pedals instead.
2. Make sure to interlock the left and right brake pedals before applying the parking brake.
3. Pull the parking brake lever up with the brake pedals depressed fully to engage the pedals with the latch. If the braking force is insufficient, depress the pedals more firmly.
4. before leaving the tractor after parking it, make sure to stop the PTO, lower the implement onto the ground, and stop the engine.
5. If it is necessary to leave the tractor with the engine running, put all the shift levers in the neutral position and apply the parking brake firmly.
6. When parking the tractor on a slope, stop the engine with the parking brake applied and engage the low speed gear. also, put the shuttle shift lever into the forward driving position on an uphill and into the reverse driving position on a downhill.
7. If it is necessary to park the tractor on a slope with the engine running, chock all four wheels and perform steps 4 and 5 above.
8. In order to release the parking brake, depress the brake pedals firmly again.

 **WARNING**

- ***If the parking brake is applied without the brake pedals interlocked, the braking force is applied to the wheel on one side only, resulting in poor braking performance and an accident.***
- ***The brake disc can be rapidly worn if you drive with the parking brake applied.***
- ***Never park the tractor on a steep slope in any circumstance. A severe accident can happen.***

⊕ ImPORTANT

- The tractor may move slowly with the engine running even though the main and shuttle shift levers are in the neutral position. This is normal and is due to the fluid friction in the transmission. This symptom can occur easily when the engine rpm is high, the low speed gear is selected by the range shift lever, and the viscosity of the transmission fluid is high due to low temperature. To prevent this symptom, make sure to apply the parking brake.
- Get off the tractor after checking that the tractor is completely stopped and the parking brake is firmly applied.
Do not park the tractor on tall grass or hay. If grass or hay contacts with the muffler, it can catch fire.

TURNING

You should turn slowly by lowering the engine rotation if possible.

⚠ WARNING

To prevent accidents due to loss of steering control:

- *If you turn at high speed, the tractor can turn over.*
- *Never use the differential lock system turning at high and low speeds. A serious accident can occur.*

DRIVING ON SLOPE

1. Please drive according to the conditions of the slope at safe speed so that the engine is not under heavy load if possible.
2. Make sure to shift to the lower gear in order to prevent the engine from stalling on an uphill.
3. on the downhill slope, drive at the low speed.

⊕ ImPORTANT

- "Unlike a gas pedal, these HST pedals act like a main speed shift in a mechanical tractor". Therefore, depress them deeper to obtain higher speed with lower torque and release them to obtain lower speed with higher torque.
- For heavy load job, such as front end loader operation, use low or medium speed of the range shift lever.

THE CAUTIONS WHEN COMING IN AND OUT OF PAVED ROAD

WARNING

- *make sure that the coupling device of brake pedal and differential lock pedal is released.*
- *Do not disengage the clutch or put the shift lever in the neutral position on a slope. Otherwise, the tractor may become inoperable.*
- *Before entering a steep slope, move the shift lever down to a proper gear and never try to move the shift lever on a slope. A serious accident can occur.*

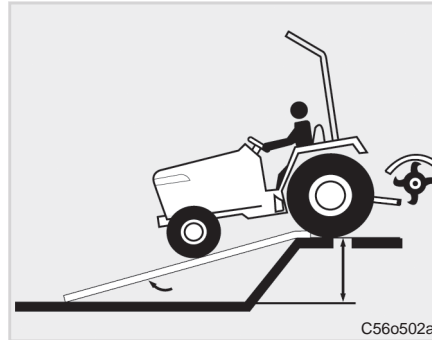

5. It is recommended to use the 4WD and drive backward when moving onto a bank.

1. Make sure that the left and right pedal are connected.
2. Go in and out of the cultivated land at a right angle.
3. Enter and exit the field by driving the tractor at a right angle to the bank.
4. When going up, lower the implement not to let the front wheel rise. raise the implement as soon as the front and rear wheels are over the bank.

PRECAUTIONS WHILE DRIVING ON THE ROAD

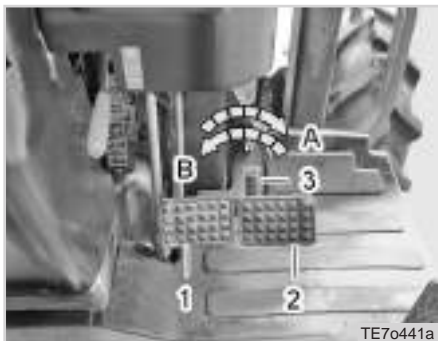

TE7o441a

- (1) Brake Pedal (LH) (2) Brake Pedal (RH)
 (3) Interlock
 (A) Engage (B) Disengage

1. When you meet another car in the opposite direction in the night, let the light be directed to the ground so that it will not interrupt another driver's view.
2. Connect the left and right brake pedal.

⚠ WARNING

- *When you are driving on the road, observe all local traffic and safety regulations. If not, you can have an accident of bodily injury on a person.*
- *Only the operator should ride on the tractor unless a passenger seat is installed.*
- *If the tractor is broken down during driving on the road, move it to a safe place to service. If not, it can cause personal injury.*

LOADING INTO AND UNLOADING OUT OF THE TRUCK



YYO186A

1. When you load the tractor, do it by driving backward.
2. If the engine stalls out halfway, step on the brake pedal at once, and then take away the pedal slowly to reach the road. after that, start the engine again to go up.

WARNING

- *When transporting the tractor with a truck, secure the tractor firmly onto the truck and be sure to aware the height of loaded tractor to avoid to hit the roof of the tunnel or the bottom of the bridge.*
- *make sure to follow this instruction as such accidents really happen.*

PRECAUTIONS WHEN USING POWER STEERING

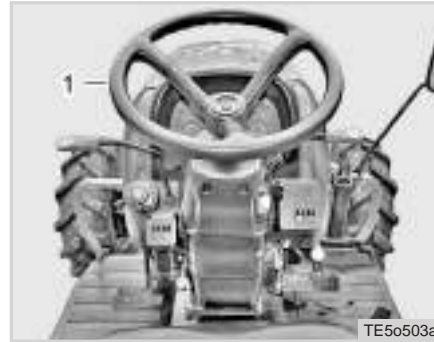

(1) Power Steering Handle

1. The power steering function is activated only while the engine is running. however, the steering wheel becomes slightly heavier when the engine is running at a low speed.
The steering wheel can be operated but becomes very heavy while the engine is stopped.
2. If you operate the steering wheel, with the tractor halted, using the implement equipped in front of the

loader and the like, the steering wheel operation can be getting a little heavy. operate the steering wheel moving the tractor in this case.

3. When a loader is mounted, adjust the air pressure of the front wheel to its maximum specification and mount weight or implement on the 3 point hitch of the tractor, and remove the front weight to make the front and rear balance more stable for safe working.
4. When turning the steering wheel to one side, the operating sound of the safety valve (relief valve) is heard. Do not operate the tractor keep the valve sound is heard continually (oK for a short period of time). The temperature of the hydraulic fluid may rise, causing malfunction.

 NOTE

- The non-load reaction type means that the reaction force or impact applied to the front axle is not transferred to the steering wheel. Therefore, this function prevents the steering wheel from returning to its original position by the resistance applied to the front wheels when turning.
- These characteristics are suitable for tractors which are driven mostly at a low speed. The features low reaction force of the steering wheel can reduce the operator's fatigue during work in which frequent turning is required. However, it may be inconvenient when driving at a high speed as the steering wheel is not automatically returned to its straight-ahead position after turning.

 NOTE

The power steering system in this tractor is a non-load reaction, full hydraulic type.

- The full hydraulic system means that power necessary for power steering is transferred by hydraulic fluid only and therefore mechanical devices, such as racks and pinions, are not installed to the tractor. This function prevents the steering wheel from returning to its original position by the resistance applied to the front wheels which are hydraulically, not mechanically, linked to the steering wheel. Therefore, the angle of the **KIOTI** emblem on the center of the steering wheel may differ occasionally, which is normal.

 WARNING

- *When driving on a road with an implement attached to the rear of the tractor, the friction of the front wheels becomes poor, resulting in poor steer ability. In this case, attach a proper front weight and drive at a low speed.*
- *If malfunction occurs while driving on a road, stop the tractor in a safe place and service it. If it is not possible to move the tractor, set a warning triangle behind the tractor. Otherwise, an tail gate accident may occur.*
- *The center of gravity of the tractor is higher compared to other common vehicles, so the possibility of the roll-over accident is very high. Be extra careful when driving on a lateral slope, bumpy road, road with puddles, and narrow road. make sure to set the ROPS in its original position and fasten the seat belt.*

⚠ WARNING

- *If stopping the engine while driving, the steering performance can become deteriorated due to loss of hydraulic power, resulting in a severe accident. Never stop the engine while driving.*
- *Do not release the steering wheel to return to the straight-ahead position after turning while driving. The steering wheel in this tractor is not a self-return type. Releasing the steering wheel while driving may lead to a massive accident.*

3-POINT HITCH CONTROL SYSTEM



(1) Position Control Lever

(A) Lowering

(B) Lifting

The 3-point hitch can be controlled by the position control lever and the draft control lever. The lever installed on the outer side (away from the driver) is the position control lever while the lever installed on the inner side (close to the driver) is the draft control lever.

POSITION CONTROL

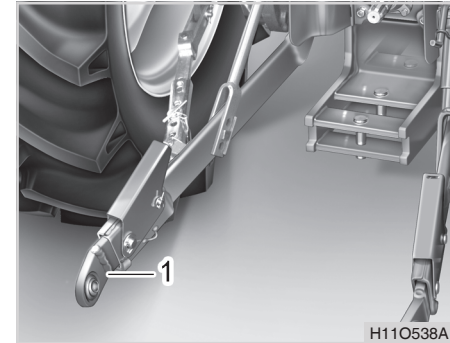

(1) Lower Link

1. The position control lever is used to lift or lower the lifting arm (lower link) of the 3-point hitch.
2. Pushing the lever forward lowers the lower link while pulling the lever backward lifts the lower link.
3. The height of the lower link is precisely controlled proportional to the position of the lever.
4. The lower link is lifted by the hydraulic energy of the tractor while

it is lowered by potential energy of its own weight. Therefore, the implement cannot be lowered by the hydraulic pressure.

5. Therefore, the implement attached to the lower link may be lifted by protrusion on the ground when it is lowered to the ground. It is called as "floating".

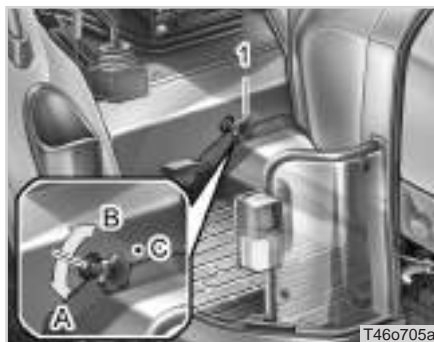

(1) Lowering Speed Control Lever
(A) High speed (B) Low Speed
(C) Slow

6. The lowering speed of the lower link is proportional to the applied weight but can be controlled by adjusting the draining passage of the hydraulic fluid. (See "Lowering speed control valve of lifting arm lower link")

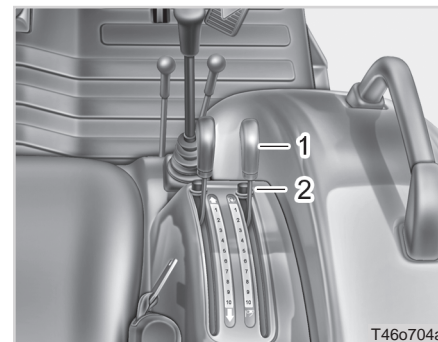

(1) Position Control Lever (2) Lock Bolt

7. The lower limit of the implement's lowering height can be set by limiting the movement of the lever by the lock bolt.

**⚠ WARNING**

- *If trying to lift an object with excessive weight by the 3-point hitch while the tractor is not equipped with proper front suit case weights, the front wheels may be lifted instead, leading to roll over. make sure to follow the specifications for use.*

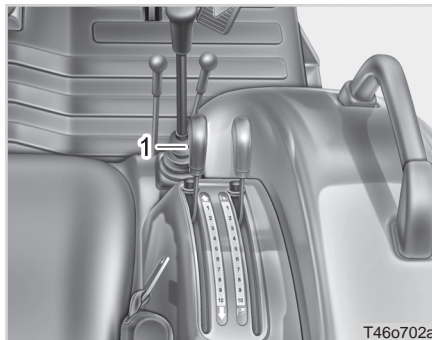
DRAFT CONTROL

(1) Draft Control Lever

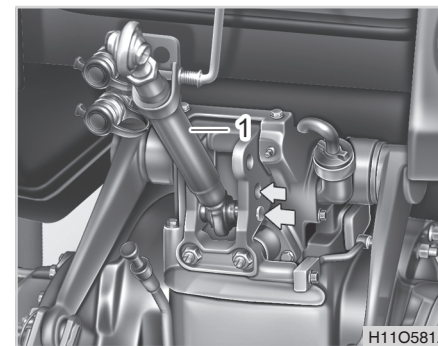

(1) Top Link

1. The draft control function is used to prevent the wheels from rotating idle and the engine from stopping due to excessive draft load when the tractor is used for work which requires a lot of draft, such as plowing.

2. The draft function is activated when the lowest or middle hole on the top link of the 3-point hitch is used. The lowest hole is for sensitive draft control.

3. To keep the plowing depth shallow, put the draft control lever to the rear (shallow) position.

The plowing depth tends to become deeper naturally by outer conditions. When the load increases by

the increase of the plowing depth while the draft control lever is set to the "shallow" position, the plowing depth is maintained as shallow because the reaction force is transferred to the internal system via the top link and the lifting arm is automatically lifted.

4. To keep the plowing depth deep, put the draft control lever to the front (deep) position.

5. The position of the draft control lever should be different based on the condition of soil to keep the plowing depth constant.

When working on a new field, it is recommended to put the draft control lever to the proper position for the desired plowing depth and lock the lever with the lock bolt.

6. When using an implement which requires no draft function, such as a rotary tiller and mower, use the highest hole on the top link and put the draft control lever in any position.

7. However, if the draft control lever is pushed forward to its end, the lowest position of the lifting arm can be lowered a little. On the other hand, if the lever is pulled back to its end, the highest position of the lifting arm can be raised a little.

CAUTION

- If the lifting arm is properly operated but abnormal noise is still heard, the hydraulic system may be malfunctioning. In this case, let the engine idle for an 10 to 15 minutes additionally and then try to start the engine again. If the problem is still present, contact your local Kioti Dealer.

CAUTION

- The implement may shake up and down as the draft sensor is under impact when the tractor is passing over irregular ground with the middle or lowest top link hole selected. In this case, put the draft control lever to the "Deep" position to decrease the sensitivity of the draft function or select the highest top link hole.
- If the tractor has been stored for a long period of time or the transmission fluid is just changed, abnormal noise may be heard and the hydraulic lifting arm may be inoperable temporarily. In this case, let the engine idle for 3 to 4 minutes.

EXTERIOR HYDRAULIC CONTROL SYSTEM DOUBLE ACTING vALvE LEVER

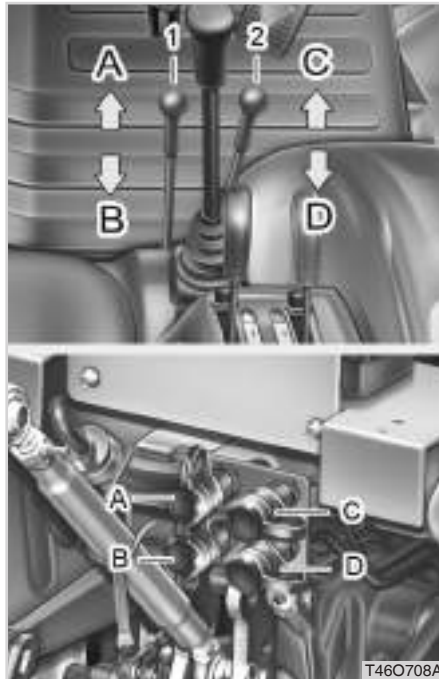

(1) Double Acting Lever 1
 (2) Double Acting Lever 2
 (A) Port A (B) Port B
 (C) Port C (D) Port D

KIOTI supplies two types of the double acting valves by region: self-return type and detent type.

- for the self-return type double acting lever, it returns to its original position to block the hydraulic fluid when it is pushed/pulled and then released. however, this type of double acting valve lever should be pulled or pushed continuously for operation which is suitable for an implement with a short operating time, such as the hydraulic cylinder.
- for the detent type double acting valve lever, it keeps its position after it is pulled or pushed to a certain position. Therefore, it is not necessary to hold the lever to a certain position which is suitable for an implement with a long operating time, such as the hydraulic motor.

⊕ ImPORTANT

- **Put the detent valve operating lever into the neutral position when the hydraulic implement is not in use. If the detent valve is kept in the operating position for an extended period of time, the relief valve is kept open and the temperature of the hydraulic fluid rises, leading to damage of various hydraulic parts, such as the oil seals and O-rings.**
- **When the detent valve is in operation, unnecessary load is applied to the engine. Therefore, the engine power decreases significantly, and noise and vibration by opening of the relief valve increase.**
- **It is hard to start the engine while the detent valve is in operation. This is especially true in winter and exhaust gas increases even after the engine is started.**

SINGLE ACTING AND DOUBLE ACTING CYLINDER

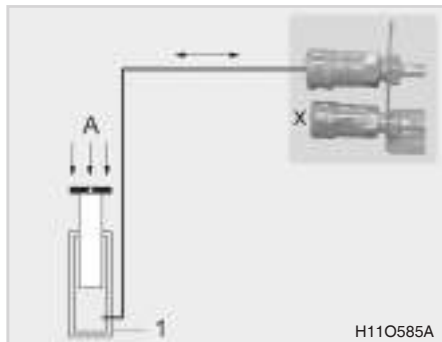

(1) Single Acting Cylinder
(A) External Load

This tractor is equipped with the remote control valve of the double acting type. however, this valve can also be used in the single acting type hydraulic cylinder.

1. Connect one end of the hydraulic port to the single acting cylinder as shown in the figure. The hydraulic pressure is properly supplied to the cylinder. however, when the hydraulic pressure is released, the cylinder is contracted only if there is outer force, such as potential energy.

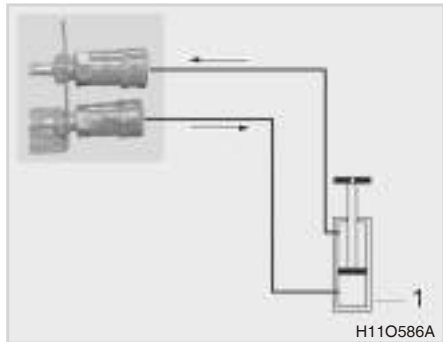

(1) Double Acting Cylinder

2. To contract the cylinder, operate the lever to the opposite position of the expansion. Then, the hydraulic fluid is supplied from the hydraulic pump to the hydraulic port which is not connected, and the pressure rises as the port is blocked. however, this pressure is released as the relief valve opens.

3. When the cylinder is contracted, the hydraulic fluid returned from the cylinder is drained to the transmission through the draining circuit as the operating lever is operated to the opposite direction from the expansion position.

⊕ ImPORTANT

- It is recommended to use the double acting cylinder instead of the single acting cylinder if the implement will be operated frequently and continuously. If using the single acting cylinder too frequently or for an extended period of time, the hydraulic fluid can be overheated, resulting in deterioration of the hydraulic parts' durability as the main relief valve opens at cylinder contraction.

PT1/2 COUPLER SOCKET (ImPLEmENT)

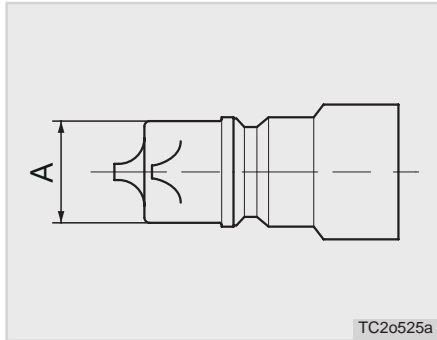

(A) Diameter

The hose unions used must comply with Iso standards.

Dimension (a) must be between 0.806 and 0.809 in. (20.48 and 20.56 mm)

CONNECTING AND DISCONNECTING ImPLEmENT HYDRAULIC HOSE

► CONNECTION

1. Make sure to stop the engine before connecting it.
2. Move the double acting valve lever forward and backward for 4 to 5 times to release the pressure in the hydraulic line of the tractor. otherwise, it is hard to connect the couplers, and hydraulic fluid can be sprayed from the line and get in to your eyes while connecting them.
3. remove any foreign material around the male and female couplers. If foreign material enters the hydraulic components, it can lead to malfunction of the system.
4. open the dust-proof cover of the female coupler of the tractor and insert the male coupler of the implement. a clicking sound is heard when the couplers are engaged.
5. Pull the hydraulic hose of the implement to check that the couplers are properly connected.
6. start the engine and check the operating status and leakage.

► DISCONNECTION

1. Make sure to stop the engine before disconnecting it.
2. release any residual pressure in the hydraulic hoses of the implement and tractor by operating the double acting valve lever 4 to 5 times.
3. remove any foreign material around the couplers.
4. Keep the implement balanced by removing any load applied (lowering it onto the ground, for example). If disconnecting the hose while outer load is applied to the implement, it is hard to connect the implement in the future.
5. remove the male coupler by pushing the female coupler boss of the tractor backward.
6. Close the dust-proof cover of the female coupler of the tractor. Wrap the male coupler of the implement with a plastic bag to prevent contamination.

 **WARNING**

- *Never connect or disconnect the implement hydraulic hose while the pressure in it is not released or the engine is running. It is hard to connect and disconnect the hose and hydraulic fluid can be sprayed from the hose, and get into your eyes or skin.*
- *Stop the engine and wear protective glasses and gloves before work.*



3-POINT HITCH IMPLEMENT AND LOADER OPERATION

6

REMOVAL AND INSTALLATION OF 3-POINT HITCH IMPLEMENT (WITH PTO SHAFT).....6-2

OPERATION TIP FOR 3-POINT HITCH ELEMENTS .. 6-5

adjustMENT of lift rod	6-5
adjustMENT of Top link	6-6
Precaution for installing how to use Top link holes.....	6-6
adjustMENT of stabilizer.....	6-7
Draft hitch and Trailer	6-7
installing Pto shaft	6-9

HANDLING LOADER 6-11

flexion points for front end loader	6-12
Driving on slope.....	6-13
joystick valve port	6-14
hydraulic block	6-15

REMOVAL AND INSTALLATION OF 3-POINT HITCH IMPLEMENT (WITH PTO SHAFT)

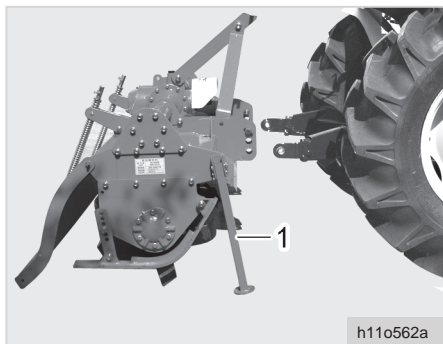

(1) Implement support

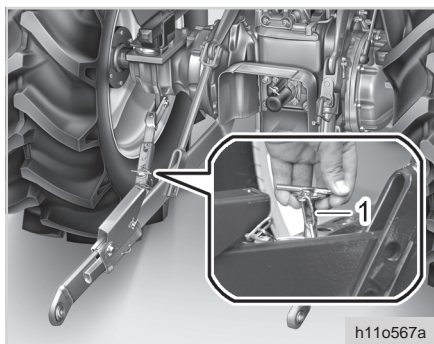

(1) Telescopic stabilizers Pin

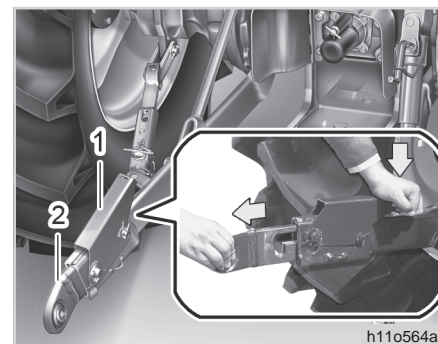

(1) latch

(2) lower link End

1. Drive the tractor backward to move close to an implement (approx. 5 cm). Then, adjust the height of the lower link to be parallel to the pins of the implement.
2. Put all the shift levers in the neutral position, stop the engine, and apply the parking brake.

3. remove both of the Telescopic Stabilizers fixing pins.

⊕ ImPORTANT

- When removing/installing an implement, remove the check link pin to use the lower link end (cassette type) effectively.

4. Press the latch to pull out the lower link end (cassette type).

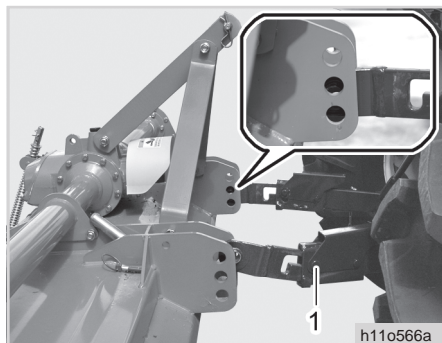

(1) lower link

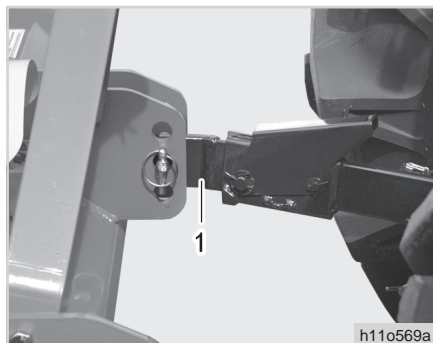

(1) lower link End

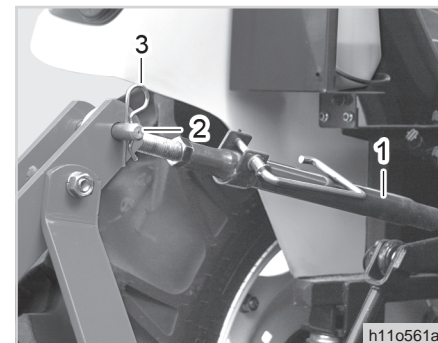

(1) Top link
(3) snap Pin

(2) lock Pin

5. Install the lower link to the implement and fit the pins.

6. start the engine and drive backward toward the implement. Then, the lower link end is inserted into its original position.

7. separate the top link from its bracket and turn it to adjust its length so that it becomes close to the upper bracket mounting hole of the implement. Then, fit it to the mounting hole, insert the lock pins, and fix it with the snap pin. Remove the implement support as necessary.

6



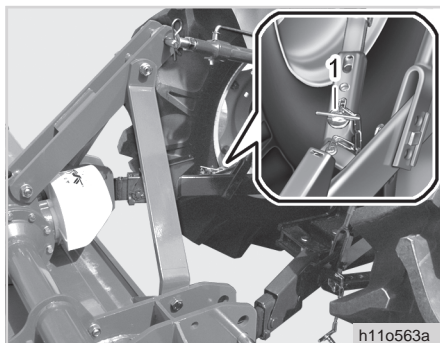

(1) Telescopic stabilizers Pin

8. Turn the top link to make the implement balanced. Then, move the implement to the left and right, and secure it into the proper position by fitting the telescopic stabilizers lock pin
9. Connect the PTO shaft to the tractor's PTO if necessary. at this time, stop the engine, lower the implement onto the ground, and set the PTO gear neutral.

⊕ ImPORTANT

- Consult your local KIOTI Dealer for selection of the PTO shaft.
- When selecting a PTO shaft, make sure there is a minimum of 6 inches (152mm) of overlap of the PTO shaft tubes when the shaft is extended to its maximum working length between the tractor and the piece of equipment. Also make sure there is 3 inches (76mm) of clearance between the shaft tube ends and the universal joints at both ends when the PTO shaft is at its shortest working length between the tractor piece of equipment. If not, **DO NOT USE** the PTO shaft and contact a KIOTI dealer.
- move the joint back and forth to check that its lock pin is properly seated to the groove of the PTO shaft.

10. remove the implement in the reverse order of installation and use the implement support as necessary.



OPERATION TIP FOR 3-POINT HITCH ELEMENTS



TE7o602a

(1) Top link
(2) lift rod

(3) Turnbuckle
(4) Telescopic stabilizers

(5) lower link
(6) Drawbar

ADJUSTmENT OF LIFT ROD



TE7o607a

(1) lift rod
(3) lock nut

(2) Turnbuckle

1. adjust the implement level balanced by turning the turnbuckle.
2. After adjustment, fix it with the lock nut.

6



ADJUSTMENT OF TOP LINK

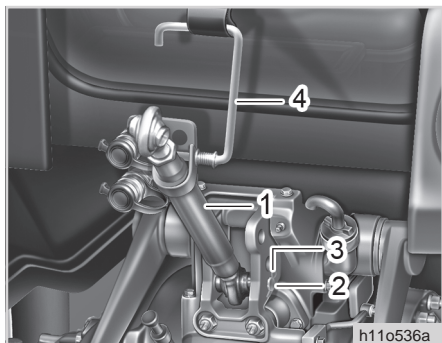

- (1) Top link (2) Pin
 (3) retainer Pin (4) Top link hook

1. Install the top link to the desired position, and install the pin and retainer pin.
2. Fix Top link with fixed nut after adjusting top link.

 **WARNING**

- *Stop the engine and lower the attachment on the ground prior to disconnecting the lift rod from the lower link. Check that the attachment for proper supporting and there's pressure remained in the hydraulic system to remove the lift rod holding the pin. To eliminate the remained pressure, move the hydraulic adjusting lever back and forth several times.*

 **NOTE**

- When there is no implement attached, fix the lower link to the check link (lh/rh) so that it does not contact with the rear wheel. secure the top link to the hook.

PRECAUTION FOR INSTALLING HOW TO USE TOP LINK HOLES

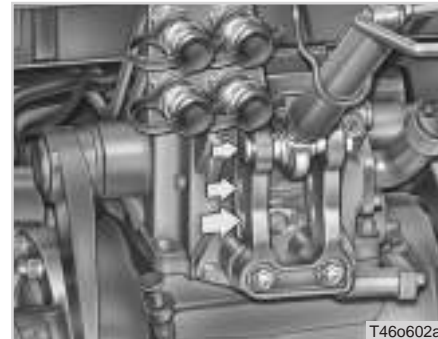

- (1) Top link

When attaching an implement, connect it according to its draft as follow:

- A : Traction power is not required (rotary etc.)
 - B : Heavy load traction work
 - C : Normal load traction work
1. adjust an angle of the implements to the desired position by shortening or lengthening the top link.
 2. adjusting a proper length of implements varies as a type of implements used.

⚠ CAUTION

- A plate describing how to attach the implement is placed on the standard implement of our company.
- When you are attaching an implement not requiring any traction, mount the assembling spot of the top link into the hole A.
- When you are attaching an implement (like plow) requiring some traction, mount the assembling spot of the top link into the hole B, C.
- When driving with an implement attached, make sure to install the top link to the hole A or B or put the draft control to the "Deep" position.

ADJUSTMENT OF STABILIZER



(1) Pin

(2) Telescopic stabilizers

adjust the telescopic stabilizers to control horizontal sway of the implement. It is also used to set the implement on the back of the tractor in center.

DRAFT HITCH AND TRAILER

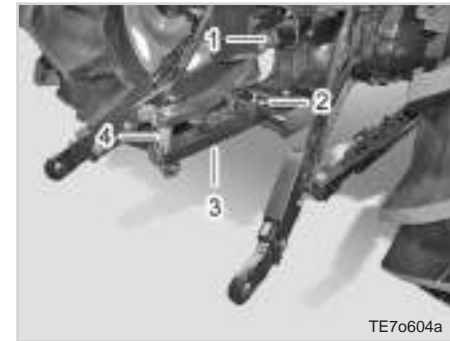
(1) PTO shaft
(3) Drawbar(2) Drawbar Pin
(a) Pin

The draw bar is used to pull an implement, such as a trailer. This tractor is equipped with a fine draw bar. Make sure to check the max. towing weight of the trailer and max. vertical load that can be applied to the draw bar.

- Max. trailer weight (trailer + loaded weight) = 3,500 kg (7,716 lbs)
- Vertical load of hitch (draw-bar) = 650 kg (1,433 lbs)

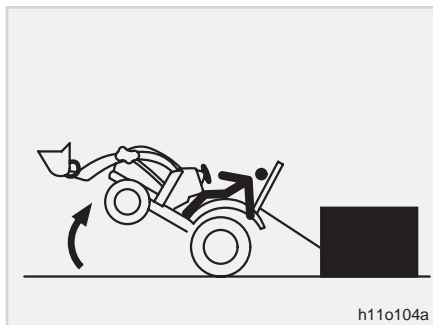
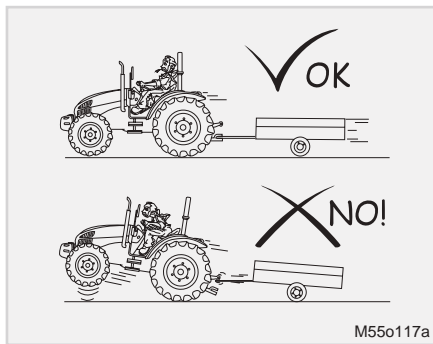

⚠ WARNING

- *Never use any other part for pulling except draw bar. Pulling with top link, ROPS and etc. will cause a fatal accident.*
- *Be sure to install the auxiliary safety chain when installing a trailer.*
- *Improper use of the draw-bar, even if correctly positioned, can cause a rear overturn.*
- *Do not overload an attachment or towed equipment. Use proper counterweights to maintain tractor stability. Hitch heavy loads to the draw-bar only.*
- *make sure that there is nobody or not obstacle between tractor and trailer.*

INSTALLING PTO SHAFT

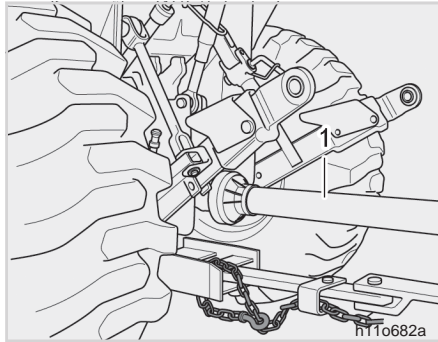

(1) PTO shaft

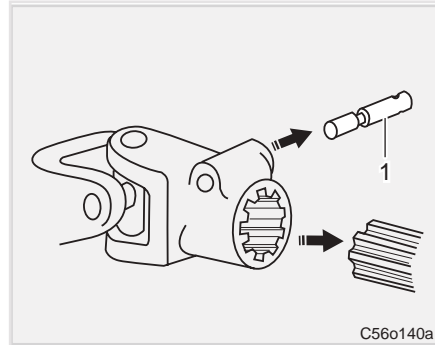

(1) lock Pin

1. Consult your local **KIOTI** Dealer for selection of the PTO shaft.
2. When selecting a PTO shaft, make sure that it is not too short to come off of the female and male shafts at the highest position or too long to impact its female and male shafts at the lowest position.
3. Move the joint back and forth to check that its lock pin is properly seated to the groove of the PTO shaft.

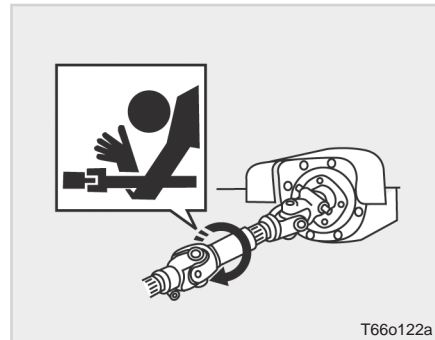

T66o122a

⚠ WARNING

- *make sure that the PTO safety cover is in its position before driving the PTO shaft.*
- *The tractor PTO and PTO shaft should not be interfered by any surrounding parts.*
- *Never go close to the rotating PTO or tractor PTO shaft. A severe accident can happen.*
- *Before driving an implement through the PTO, always make sure that all bystanders are well away from the tractor.*
- *When using the PTO drive with a stationary tractor, always make sure that the gears are in neutral and that the parking brake is applied.*

⚠ WARNING

- *Before starting up any PTO-driven implement hitched to the three-point linkage, lift the implement to its full height and check that at least 1/4 of the total length of the telescopic section of the drive shaft is engaged.*
- *Before starting up any PTO-driven implement hitched to the three-point linkage, lift the implement to its full height and check that at least 1/4 of the total length of the telescopic section of the drive shaft is engaged.*

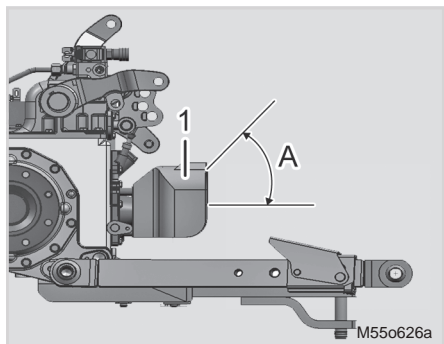

(1) PTO Cover

(A) Allowable angle of universal joint : 50°

ref to the chart below as to installing of an universal joint.

The type of PTO shaft	Allowable angle of universal joint
saE 1-3 / 8 " 6 splines	50 degree



HANDLING LOADER



TE7o605a

- (1) loader Mounting bracket
- (2) balancing Cylinder
- (3) loader arm
- (4) boom
- (5) Grill Guard
- (6) Tilt Cylinder
- (7) bucket

for detailed information about installation and use of the front loader, refer to the separate manual of the loader.

ImPORTANT

- **Check the transmission fluid level and add fluid as necessary after installing an implement related to the hydraulic fluid, such as a loader or backhoe, and driving the tractor for a test.**



FIXATION POINTS FOR FRONT END LOADER

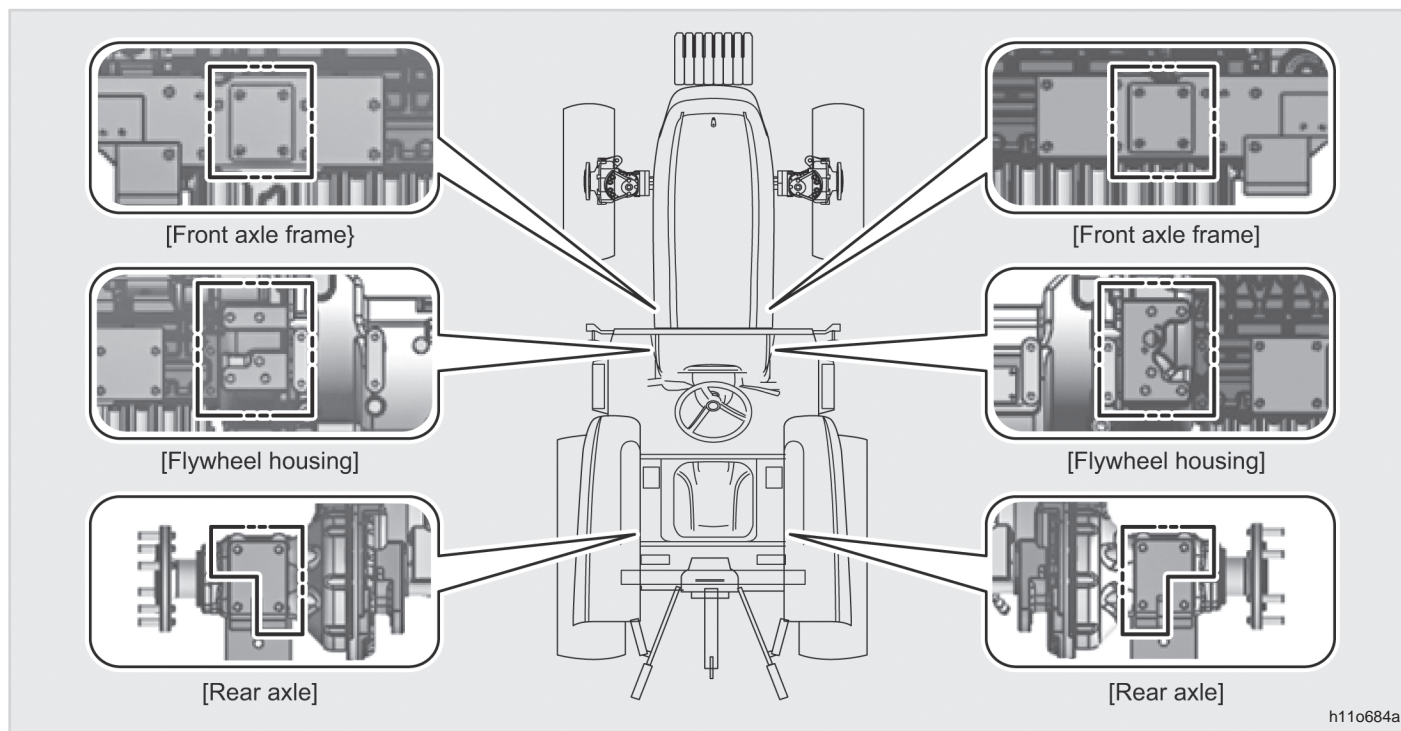

⚠ WARNING

- *When you do install the front loader, certainly mount the bolt for mounting bracket at indicated point.*



DRIVING ON SLOPE WHEN LOADED BUCKET AND REAR BALLAST ARE INSTALLED

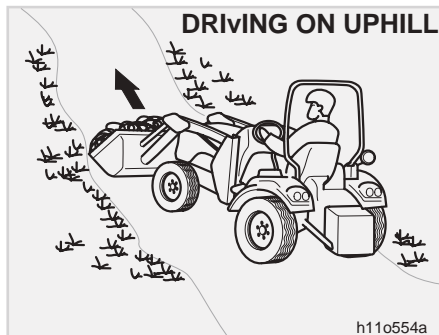

When driving on uphill with the load-
ed bucket and rear ballast installed,
keep the higher end of the tractor
heavier. In other words, drive forward
on uphill and backward on downhill.

! WARNING

To avoid injuries:

- *Keep the loader arm as low as possible when driving on a slope.*

WHEN UNLOADED BUCKET AND REAR BALLAST ARE INSTALLED



When driving on downhill with the empty bucket and rear ballast installed, keep the rear ballast toward the higher level of the ground. In other words, drive backward on uphill and forward on downhill.

use the 4WD to increase friction when driving on a slope with the loaded bucket and rear ballast installed.

set the bucket and implement high on a rough surface so that they are not caught by obstacles.

PARKING WITH LOADER INSTALLED

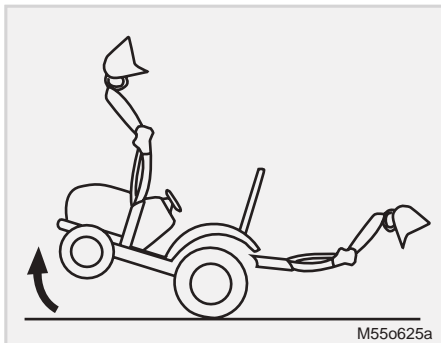

JOYSTICK VALVE PORT



(E) bucket up
(G) boom up

(f) bucket Down
(h) boom Down

⚠ CAUTION

- When parking a tractor which is equipped with a loader or backhoe, make sure that the bucket of loader or backhoe is lowered on the ground. Otherwise, the tractor can become unstable, leading to an unexpected accident, such as roll over.

PORT	DIRECTION	FUNCTION
E		bucket up
f		bucket Down
G		boom up
h		boom Down

HYDRAULIC BLOCK

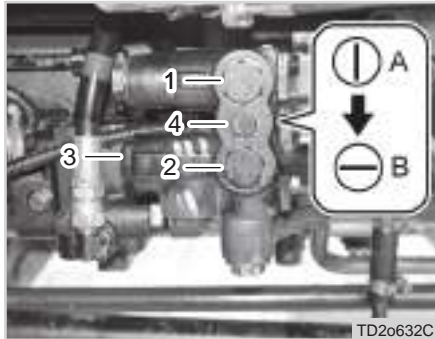

- (1) In (from Implement's Control valve)
 (2) out (To Implement's Control valve)
 (3) return (from Implement's Control valve)
 (4) flow Plug
 (a) off (b) on

NOTE

- The hoses and couplers for installation are supplied with the loader.
- For detail about implement installation method, refer to **KIOTI** front loader owner's manual.

WARNING

- *Never let anyone get in the loader and use the loader as a workbench. Otherwise, it may lead to injury or even death.*
- *Do not stand under the lifted loader or get close to it. Also, lower the loader arm onto the ground before leaving the tractor. Otherwise, it may lead to injury or even death.*
- *Never carry a big object with the loader unless a proper implement is attached. Keep a carried object low during driving. Otherwise, it may lead to injury or even death.*

WARNING

- *When attaching or detaching the loader, fix all parts which are connected to the bucket and boom. The bucket or boom can be accidentally dropped down, leading to injury or even death.*
- *Do not allow loader arms or attachment to contact electrical power lines. Electrocutation will cause serious injury or death.*

ImPORTANT

- **ROPS (Roll Over Protective Structure), sun canopy or cabin are not a FOPS (Falling Object Protective Structure). It never can protect the riders against falling objects. Avoid driving the vehicle into a dangerous area such as falling rocks zone. Otherwise, it may lead to a serious injury.**



mEmO





mAINTENANCE

mAINTENANCE CHECK LIST 7-3

- DAILY ChECK ITEM 7-3
- MAINTENANCE sChEDuIE Char T..... 7-4

LUBRICANTS 7-7

mAINTENANCE CODE..... 7-8

- hOW T o oPEn ThE hooD(a) 7-8
- ChECKInG anD aDDInG fuEl(C) 7-8
- ChECKInG TransMIssIon fluiD IEvEl(D) 7-9
- ChECKInG EnGInE oIl IEvEl(E) 7-10
- ChECKInG CoolanT IEvEl(f)..... 7-11
- CIeanInG Grill, raDla Tor sCrEEEn(G) 7-12
- ChECKInG braKE PEDals(h) 7-12
- ChECKInG GauGES, METEr anD EasY ChECKEr (l)..... 7-13
- ChECKInG hEaD lIGHt , hazarD lIGHt ETC. (j) 7-13
- ChECKInG sEa T bEl T anD CabIn (K)... 7-13
- ChanGInG EnGInE oIl anD rEPlacInG flI TEr(l) 7-13

- rEPlacInG TransMIssIon fluiD anD flI TEr(M) 7-15
- ChanGInG front axIE CasE oIl(n) .. 7-17
- aDjusTInG braKE PEDal(o) 7-18
- lubrIca TInG GrEasE loCa Tions(P) . 7-19
- ChECKInG WhEEl bol T / nuT TorQuE(Q)..... 7-20
- fuEl flI TEr (s)..... 7-20
- rEPlacInG alr CIeanEr PrImarY EIEMEnT(T)..... 7-21
- ChECKInG fuEl lInEs (u) 7-22
- aDjusTInG CluTCh PEDal(u1) 7-23
- aDjusTInG fan bEl T TEEnslon(v)..... 7-23
- baTTERY(W)..... 7-24
- ChECKInG InT aKE alr lInE (x) 7-26
- aDjusTInG ToE-In(Y) 7-26
- ChECKInG raDla Tor hosE anD ClaMP(z) 7-27
- POWEr sTEErInG lInE(aa) 7-28
- aDjusTInG front axIE PlvoT(aD)..... 7-28
- aDjusTInG EnGInE v alVE CIear- anCE(aE) 7-29

7

7





*m*AINTEANCE

rEPlACInG aIr ClEanEr flI	TEr (af) ...	7-29
flush CoollnG sYsTEM anD		
ChanGInG CoolanT(aj)		7-30
anTIfrEEzE(aK)		7-31
DrainInG Wa TEr froM CluTCh		
housInG(al)		7-32
blEEDInG fuEl sYsTEM(aM)		7-32
rEPlACInG fusE(an)		7-33
sloW bloW fusE(aP)		7-35
rEPlACInG bulb(aQ)		7-36



mAINTENANCE CHECK LIST

DAILY CHECK ITEM

SERVICE SCHEDULE		mAINTENANCE CODES
ITEM	SERVICE REQUIRED	
Engine oil	Check the oil level and add as needed. Do not overfill.	E
hydraulic (Trans / Diff.) fluid	Check level and add as needed.	D
Engine air filter and air Intake system	Check restriction indicator. (If equipped) Check for leaks and damaged components. Do not use compressed air to clean elements.	T
Engine Cooling system	Clean debris from oil cooler, radiator screen and grills. Check coolant level cold, add premixed coolant as needed.	f, G, aC
seat belt	Check the condition of seat belt and mounting hardware. repair or replace as needed.	
Tires	Check for wear, damaged tires and ensure for proper sized tires and correct air pressure.	
Parking brake	Check operation and adjust if required.	
Clean Pedals	Clean brake pedals, travel control pedal, clutch pedal and footrest area.	h
General Items	Check for loose or broken parts, damaged operator cab, instrument operation, loose wheel nuts / bolts, oil leaks and damaged or missing signs. (Decals)	Q, aG, ah, aM
PTo	Inspect the splines. replaced damaged or missing shields and guards.	
Three-point linkage	Check operation and condition of pins, links and bars.	
Loader (If Equipped)	Check mounting hardware for loose or broken parts.	

※ f or detailed information about maintenance codes, refer to the corresponding section in each chapter.

MAINTENANCE SCHEDULE CHART

NO.	Item	maintenance interval	Run hour										Run age		Remarks	maintenance codes			
			50	100	200	250	400	500	600	800	1000	1500	3000	1Year			2Year		
1	Engine oil & filter	Change					○							○				l	
		Check			○														
2	Transmission oil filter	replace	⊙		○													M	
3	Transmission fluid	Change					○											M	
4	front axle oil	Change					○											n	
5	front axle pivot	adjust							○										
6	Engine start system	Check	○																
7	Greasing	apply	○															P	
8	Wheel bolt torque	Check	○															Q	
9	battery condition	Check		○													* 3	W	
10	air cleaner element	Clean		○													* 1	#	T, af
		replace											○			* 2			
11	Fuel filter element	replace						○										#	s
12	fan belt, air-con belt	adjust		○													* 3	v, ab	
13	Clutch pedal free play	adjust	⊙	○														o	
14	brake pedal free play	adjust	⊙	○														r	

NO.	Item	maintenance interval	Run hour										Run age		Remarks	maintenance codes		
			50	100	200	250	400	500	600	800	1000	1500	3000	1Year			2Year	
15	radiator hose and clamp	Clean																G
		Check			○													z
		replace													○			
16	Power steering hose and oil line	Check			○												aa	
		replace												○				
17	fuel line	Check		○													#	u
		replace												○				
18	Intake air hose	Check			○													x
		replace												○	* 3			
19	PTo shaft and guard condition	Check		○														
20	3 point hitch and draw-bar condition	Check		○														
21	secure pins	Check		○														
22	Tire pressure and damage	Check		○														
23	Parking brake condition	Check		○														
24	Toe-in	adjust			○												Y	

NO.	Item	maintenance interval	Run hour										Run age		Remarks	maintenance codes			
			50	100	200	250	400	500	600	800	1000	1500	3000	1Year			2Year		
25	Engine valve clearance	adjust																	
26	fuel injection nozzle Injection pressure	Check																	#
27	Injection pump	Check																	#
28	Cooling system	Clean																	
29	Coolant	replace																	
30	Air-con filter	replace																	
31	fuel system	Check																	* 3
32	fuse	replace																	* 3
33	light bulb	replace																	

+ IMPORTANT

- ○ must be done after the first 10 or 50 hours of operation.
 - * 1 Air cleaner should be cleaned more often in dusty conditions than in normal condition.
 - * 2 Every year or every 6 times of cleaning. * 3 Replace only if necessary. * 4 Every 3 year
- The items listed above (# marked) are registered as emission related critical parts by KIOTI in U.S.EPA exhaust emission standard non-road emission regulation. As the engine owner, you are responsible for the performance of the required maintenance on the above instruction.

LUBRICANTS

To prevent serious equipment damage, use only genuine **KIOTI** fluids, oils and greases, or equivalents.

NO.	SECTION	CAPACITY [L (U.S.gal.)]	LUBRICANTS
1	fuel	50 (13.2)	ultra-low sulfur diesel (sulfur content: 10 ppm or less)
2	Coolant	7.7 (2.03)	a n antifreezing solution(Ethylene glycol) + Pure water (50 : 50)
3	Engine oil (filter Included)	7.4 (1.95)	aPI Cj grade above saE 10W30, 10W40, 15W40
4	Transmission oil	ns4710/6010 : 43 (11.36) ns4710h/5310h/6010h : 36(9.51)	Daedong : s-uTf 38 Exxonmobil : Mobilfluid 350 shell : Donax-TD low v is bP : auTran sYn 29 Petro-Canada : Duratran xl synthetic blend
5	front axle oil	8.5 (2.25)	saE 90 gear oil or better, or same as T/M oil
6	Grease - Ref to "Grease fitting location" in chapter 7.	a little	Multi purpose type grease

WARNING

- **Check the oil level regularly. Correct the oil level, if needed, before operating.**
- **Always check and add oil with the tractor on a flat, level surface.**
- **The KIOTI genuine brake fluid is mineral oil based fluid. Never use vegetable oil-based fluid for automobile.**

MAINTENANCE CODE

HOW TO OPEN THE HOOD(A)



(1) opening Knob (2) hood
(a) Pull

1. The hood can be opened by pulling the handle on the lower right of it while pressing its front down.
2. To close the hood, press down the front section of the hood until it is locked into its original position.
3. Do not apply excessive force to the lever to fix the hood. The hood can be damaged.



(1) hood

⚠ CAUTION

- **Never open the hood while the engine is running.**

CHECKING AND ADDING FUEL(C)



(1) fuel Tank Cap

The fuel tank cap is automatically locked as it is tightened. To fuel, unlock the cap with the ignition key before opening it.

Fuel Tank Capacity

50 l (13.2 u.s.gal.)

1. Turn the key switch to "on", check the amount of fuel by fuel gauge.
2. If the needle on the fuel gauge is close to "E" or the fuel level is low, open the fuel tank filler cap and add the fuel.
3. after adding the fuel, close the fuel tank filler cap.

⚠ CAUTION

To avoid personal injury :

- Do not smoke while refueling.
- Add the fuel in a well-ventilated area.
- Be sure to stop the engine before refueling.
- Dirt or sand contained in fuel may cause the fuel injection pump to malfunction, use the strainer when refuelling.

⊕ IMPORTANT

- Be careful not to spill during refueling. If a spill occur, wipe it off at once, or it may cause a fire.
- If unit is not used for a long time, make sure the fuel viscosity is suitable for the cold weather.

CHECKING TRANSMISSION FLUID LEVEL(D)

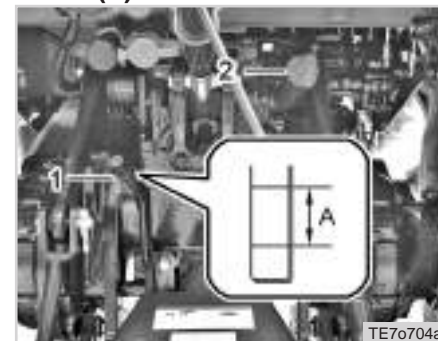

(1) Gauge (2) oil Inlet
(a) oil level is acceptable within this range

1. Park the machine on a flat surface, lower the implement and shut off engine.
2. Depress the brake pedals and apply the parking brake.
3. set all shift levers into the neutral position.
4. stop the engine.



(1) oil Dipstick
(a) upper limit

(b) lower limit

5. Pull out the oil dipstick, clean it, and then insert it into its original position. Then, pull it out again and check if the oil level is within the specified range.
6. If the oil level is too low, add some new oil so that the level is within the allowable range. (refer to "Lubricant" in this chapter for fluid specs)

⊕ IMPORTANT

- If oil level is low, do not run engine.
- Never add the oil over the upper limit.
- Be sure to check the oil level after installing hydraulic implement. Add the fluid as needed.
- Check the oil level with the cylinders of an implement extended and check again with cylinders retracted. Add the oil to adjust average oil level in the range of the oil limit. (Upper or lower)

CHECKING ENGINE OIL LEVEL(E)

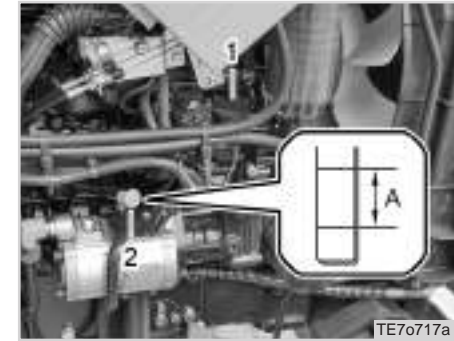

(1) oil Inlet (2) Dipstick
(a) oil level is acceptable Within This range.

1. Check the engine oil daily.
2. Park the tractor on a level ground and lower the implement.
3. If the engine was just running, wait for approx. 5 minutes before checking the oil level.

⚠ CAUTION

To avoid personal injury :

- Be sure to stop the engine before checking the oil level.

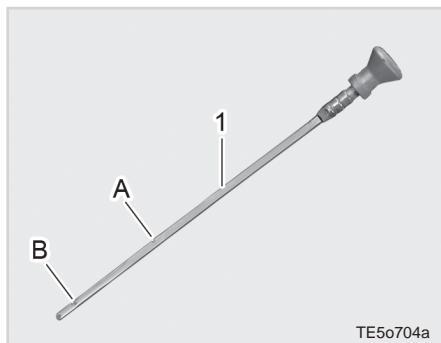

TE5o704a

(1) oil Dipstick

(a) upper limit

(b) lower limit

4. Pull out the oil dipstick, clean it, and then insert it into its original position. Then, pull it out again and check if the oil level is within the specified range.
5. If the oil level is too low, add some new oil so that the level is within the allowable range.

⊕ IMPORTANT

- When using oil of different maker or viscosity from the previous one, remove all of the old oil. Never mix two different types of oil.
- Do not start the engine when the oil level is below lower limit.
- Wipe the oil dipstick with clean cloth or tissue. If foreign material enters the oil sump, it can lead to malfunction of the engine.
- Never add the oil over the upper limit.

CHECKING COOLANT LEVEL(F)

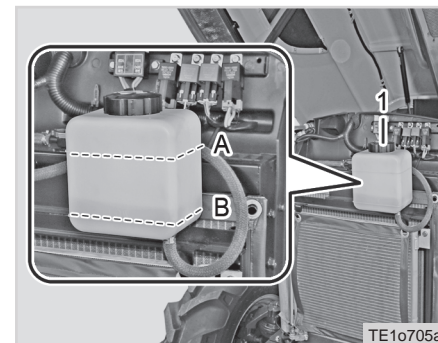

TE1o705a

(1) reserve Tank

(a) full

(b) loW

1. Check to see that the coolant level is at the "loW" or higher level of the reservoir tank.
2. When the coolant level drops due to evaporation, add water only up to the "MIn" mark or higher level of the reservoir tank. In case of leakage, add anti-freeze and water in the specified mixing ratio up to the "loW" mark or higher level.
3. The tractor is furnished in the factory with a mixture of anti-freeze (ethylene glycol) and water in a ratio of 50 : 50 which is usable in any season.

7

CLEANING GRILL, RADIATOR SCREEN(G)



(1) radiator screen
(a) Detach

1. Check front grill and side screens to be sure they are clean of debris.
2. lift out the radiator screen and remove all the foreign material.

CAUTION

To avoid accidents :

- Be sure to stop the engine before removing the screen.

IMPORTANT

- Bonnet Grill and screen must be clean from debris to prevent engine from overheating and to allow good air intake for the air cleaner.

CHECKING BRAKE PEDALS(H)

1. The brake pedals should be inspected for free travel, and smooth operation.
2. You should adjust this pedal if an incorrect measurement is found. (see maintenance code "o" and "r" in this chapter)

NOTE

- When checking the brake pedals separated, both of the brake pedals should move down to the same depth.

CHECKING GAUGES, mETER AND EASY CHECKER (I)

1. Inspect the instrument panel for broken gauge (s), meter (s) and Easy Checker lamps.
2. replace if broken.

CHECKING HEAD LIGHT, HAZ-ARD LIGHT ETC. (J)

1. Inspect the lights for broken bulbs and lenses.
2. replace if broken.

CHECKING SEAT BELT AND CABIN (K)

1. always check condition of seat belt and attaching hardware before operating tractor.
2. replace if damaged.

CHANGING ENGINE OIL AND REPLACING FILTER(L)

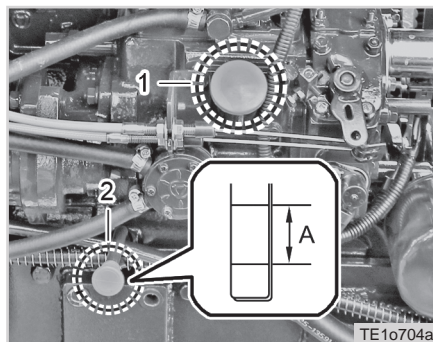

(1) oil Inlet

(2) Dipstick

(a) oil level is acceptable within this range



(1) Drain Plug

1. Park the tractor on a level ground and start the engine to warm it up.

2. stop the engine, apply the parking brake, and remove the drain plug.
3. remove the drain plug at the bottom of the engine and drain the oil completely. all the used oil can be drained out easily when the engine is still warm.

be sure to put the drain plugs to the oil sump securely.

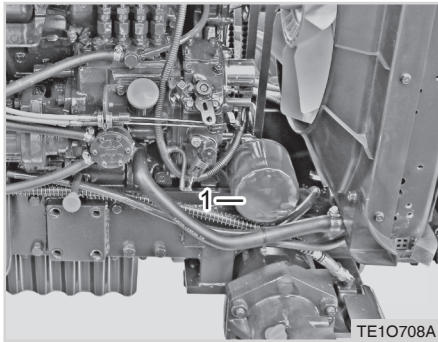

(1) Engine oil filter

4. Remove the oil filter behind the cooling fan on the right side of the engine.
5. Apply a thin film of oil to the O-ring of a new filter and tighten the O-ring firmly by hand.
6. Fill the engine oil to the specified level and tighten the oil filler cap.

Engine Oil Capacity (Filter Included)

7.4 l (1.95 u.s.gal.)

7. Run the engine for approx. 5 minutes to deliver oil to each part.
8. Engine oil light should go off after 10 seconds of running. If the oil pressure light stays on, stop the engine.
9. Check the engine oil level again with the oil dipstick. If the level is low, add more oil.

NOTE

- The engine oil filter should be replaced when changing the engine oil.

⚠ WARNING

- *The engine oil is very hot while the engine is running or right after the engine is stopped. Be careful not to be burned.*
- *Avoid oil contact while changing or adding engine oil and wear eye protection to prevent eye contact.*
- *Prolonged and repeated contact with the engine oil may cause skin disorders and skin cancer. If skin contact is made, wash thoroughly with soap or hand cleaner as soon as possible.*
- *Keep the used oil out of reach of children.*
- *Using low quality engine oil can damage the after treatment system.*

REPLACING TRANSMISSION FLUID AND FILTER(M)

⚠ CAUTION

To avoid personal injury :

- Be sure to stop the engine before changing the oil or replacing the filter.
- Check the engine oil level before every operation of the tractor. If the engine oil is insufficient, the engine can be damaged, and this is not covered by warranty. Be sure to add the engine oil when its level is below the lower limit of the oil dipstick.
- Do not dispose of used oil and oil filter into drainage and other places not designated by regulations. Observe applicable regulations when disposing used oil and filters.

⊕ IMPORTANT

- Use only KIOTI genuine engine oil and filters to insure smooth operation and durability of the engine.

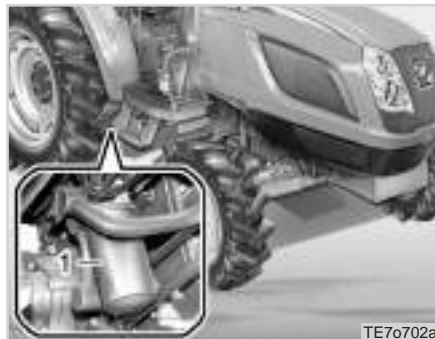

(1) oil filter Cartridge

The transmission fluid should be changed if it is contaminated or after the transmission is serviced or every 800 hours of operation. When changing the transmission fluid, make sure to change the fluid filter. however, replace the filter only at initial 50 hours and every 400 hours operation afterward.



(1) Drain Plug

1. Park the tractor on a level ground and start the engine to warm it up.
2. stop the engine, apply the parking brake, and remove the drain plug.
3. To drain the used fluid, place the oil container under the transmission case and remove the drain plug to drain used fluid. If the fluid does not flow out freely, unscrew

1. Park the tractor on a level ground and start the engine to warm it up.
2. stop the engine, apply the parking brake, and remove the drain plug.
3. To drain the used fluid, place the oil container under the transmission case and remove the drain plug to drain used fluid. If the fluid does not flow out freely, unscrew the breather plug on the top of the hydraulic cylinder on the behind of the top link bracket to facilitate drainage. (ref to next page)
reinstall the drain plugs securely afterward.
4. unscrew the fluid filter from the rear right section on the tractor using a filter wrench.

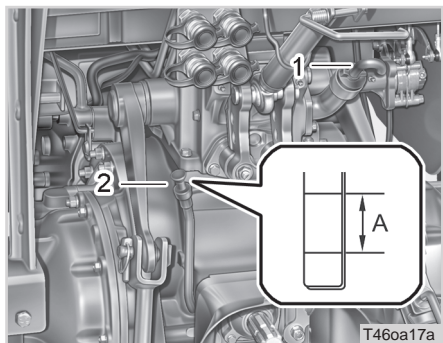

(1) oil filler Plug (2) Gauge
(a) oil level is acceptable within this range

5. Apply a thin film of clean oil onto the O-ring of a new filter.
6. Tighten the filter firmly by hand.
7. run the engine for a few minutes and then stop it to check the leakage and fluid level. Add fluid to the specified level as needed.

Transmission Oil Capacity

52 l (13.74 u.s.gal.)

⚠ CAUTION

To avoid personal injury :

- Be sure to stop the engine before changing the fluid or replacing the filter.
- Cool down the fluid sufficiently. You can get burned by hot fluid.

⊕ IMPORTANT

- To prevent serious damage to the hydraulic system, use only a KIOTI genuine filter.
- Do not operate the tractor with heavy load right after changing the transmission fluid. Run the engine at medium speed for a few minutes to prevent damage to the hydraulic system.

CHANGING FRONT AxLE CASE OIL(N)

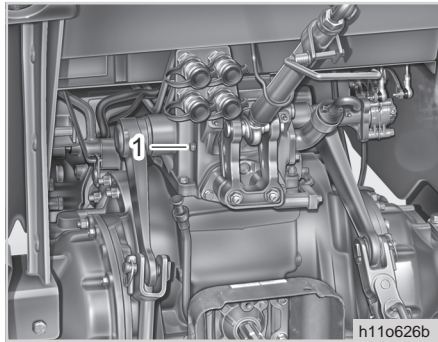

h11o626b

(1) air bleeding Plug

⊕ IMPORTANT

- When adding the fluid, unscrew the bleeding plug on the top of the hydraulic cylinder. Other-wise, the fluid can overflow.

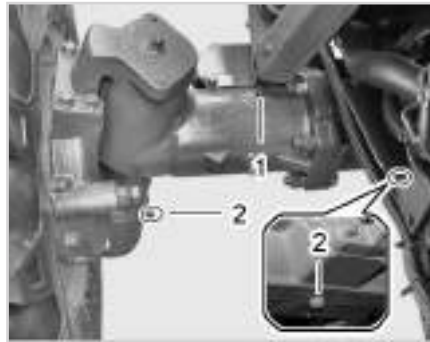

TE6o715a

(1) Check & Filling Plug
(2) Drain Plug

1. To drain the used oil, remove the right and left drain plugs and filling plug at the front axle case and drain the oil completely into the oil pan.
2. after draining, reinstall the drain plugs.
3. remove the oil level checking plug on the left of the front axle.
4. Add new oil to the specified level through the oil filler.
5. Wait at least 15 minutes to allow the oil flow to the bevel case before checking the oil level.
6. add oil as necessary and tighten the oil filler plugs and oil level checking plug.

Front Axle Oil Capacity

8.5 l (2.25 u.s.gal.)

ADJUSTING BRAKE PEDAL(O) BRAKE PEDAL FREE PLAY

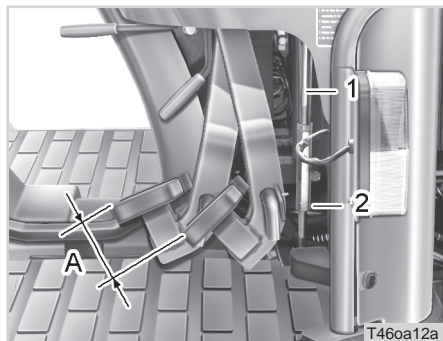

- (1) brake Pedal (2) Push rod
(3) lock nut (4) Master Cylinder
(a) free Play

1. slightly depress the brake pedal and measure its free play.
2. If the free play is out of the specification, adjust the length of the push rod.
3. Tighten the lock nut firmly after adjustment.

Pedal Free Travel (A)

20~30 mm (0.787 ~ 1.181 in.)

⚠ WARNING

- *Make sure that the push rod does not push the piston with the pedal released.*



LUBRICATING GREASE LOCATIONS(P)

Apply high-quality multi-purpose grease onto the positions in the figure at every 50 hours of operation or whenever necessary and record the operating time when applying it.

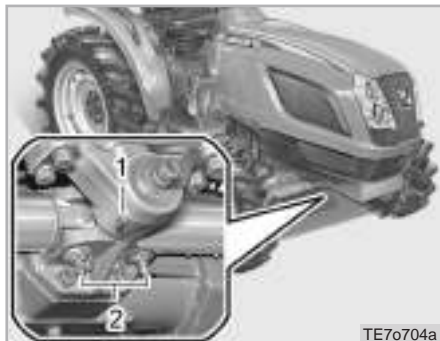

TE7o704a

- (1) Grease fitting (front bracket axle pivot)
- (2) Grease fitting (Power steering cylinder)(rh, lh)

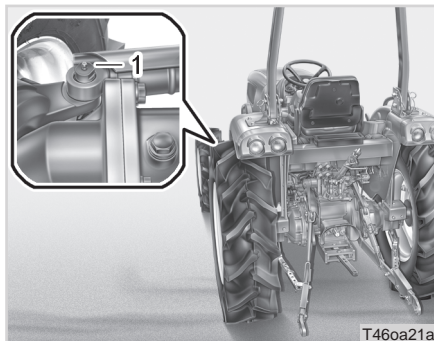

T46oa21a

- (1) Grease fitting (Power steering cylinder) (rh, lh)

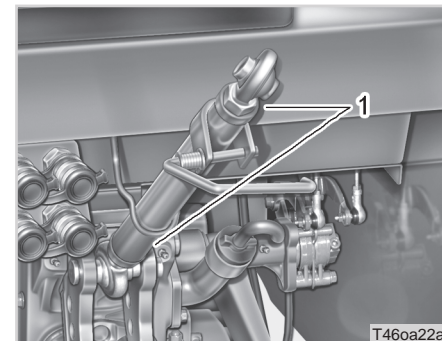

T46oa22a

- (1) Grease fitting (Top link bracket)



TE7o705a

- (1) Grease fitting (brake lever rh, lh)



TE7o706a

- (1) Grease fitting (rear bracket axle Pivot)

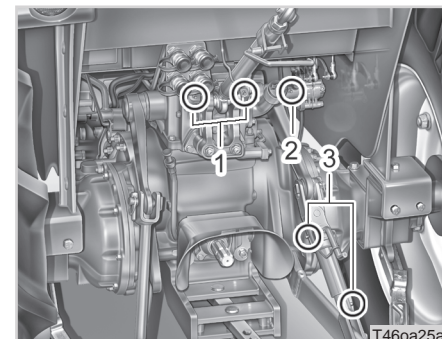

T46oa25a

- (1) Grease fitting (Top link holder)
- (2) Grease fitting (hydraulic Cylinder support)
- (3) Grease fitting (lift rod)



CHECKING WHEEL BOLT / NUT TORQUE(Q)



TE70719A

- (1) front Wheel bolt / nut
(2) rear Wheel bolt / nut

Check wheel bolts and nuts regularly especially when new. If they are loose, tighten them as follows.

Item		Tightening Torque
front wheel	bolt	196 ~ 225.6 n·m 144 ~ 166 lbf·ft
	nut	20 ~ 23 kgf·m
rear wheel	bolt	196 ~ 225.6 n·m 144 ~ 166 lbf·ft
	nut	20 ~ 23 kgf·m

⚠ CAUTION

To avoid personal injury :

- Never operate tractor with a loose rim, wheel, or axle.
- Any time bolts and nuts are loosened, retighten to specified torque.
- Check all bolts and nuts frequently and keep them tight.

FUEL FILTER (S) REMOVING WATER FROM FUEL FILTER

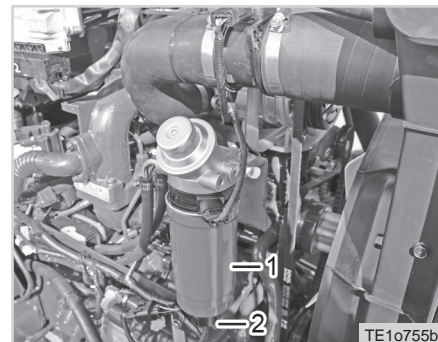

TE1o755b

- (1) fuel filter (2) Drain Plug

1. Water and dust in fuel are accumulated in the filter. Remove the plug from the bottom of the fuel filter to drain any impurities.
2. Tighten the filter with a hand (not a tool) after drainage.
3. start the engine and check for fuel leakage.

REPLACING FUEL FILTER

1. Wipe the surface of the fuel filter clean.
2. unscrew the plug on the bottom of the fuel filter to drain fuel.
3. Remove the fuel filter.
4. remove foreign materials, such as dirt, thoroughly and replace the fuel filter with a new one.

REPLACING AIR CLEANER PRIMARY ELEMENT(T)



(1) Element
(2) Cover

(3) Evacuator valve

1. The air cleaner uses a dry element. never apply oil.
2. Dust should not accumulate in the evacuator valve. remove and clean it. Clean the element and filter assembly every week. If the tractor is operated in extremely dusty conditions, daily inspection is required.
3. Do not service the filter unless it should be cleaned.
4. If the element is stained with carbon , dust or oil, replace the filter.

5. For filter replacement, refer to the instruction for replacing the air cleaner filter for every year.

To clean the element, use only clean dry compressed air on the inside of the element. air pressure at the nozzle must not exceed 29 psi (2 kgf/cm²). Maintain reasonable distance between the nozzle and the filter.

⊕ IMPORTANT

- **The air cleaner will only fulfill its function if it is correctly and regularly maintained. A poorly maintained air cleaner will mean loss of power, excessive fuel consumption and a reduction in engine life.**
- **Do not run the engine with filter element removed.**

CHECKING FUEL LINES (U)

⊕ IMPORTANT

- Be sure to refit the cap with the arrow ↑ (On the rear of cover) upright. If the cap is improperly fitted, evacuator valve will not function and dust will adhere to the element.
- Be sure to check any air leak or opening in the air intake system. Even the small gap or opening in the air intake system can cause the serious engine problem after a few years of operation.

EVACUATOR VALVE

open the evacuator valve once a week under ordinary conditions or daily when used in dusty conditions to get rid of large particles of dust and dirt.

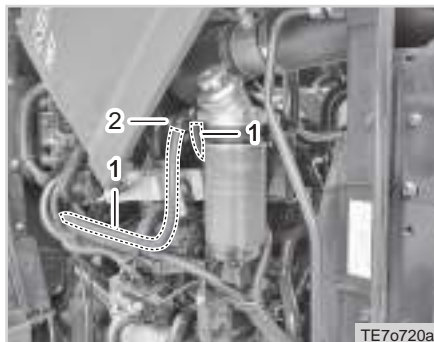

(1) fuel Pipe

(2) Tightening band

although checking the fuel pipe connection is recommended every 100 service hours, it should be done every 6 months if operation does not exceed 100 hours in 6 months.

1. If the hose clamps are loose, apply a slight coat of lubricant onto the threads and securely tighten it.
2. The fuel pipe is made of rubber and ages regardless of period of service. Change the fuel pipe together with the hose clamps every two years and securely tighten.

3. If the fuel pipes and hose clamps are found damaged or deteriorated earlier than two years, then change them immediately.
4. after the fuel pipe and hose clamps have been changed, bleed the fuel system.

⚠ WARNING

- Stop the engine when checking the items above.
- The fuel pipes are subject to wear and aging. Failure to perform periodic inspections may lead to a fuel leak. Fuel leaking on a hot engine could cause a fire.

⊕ IMPORTANT

- When changing fuel pipes, be careful not to allow dust or dirt to enter the fuel system. Contaminations in the fuel system could damage the fuel system or injection pump. Pay extra caution to the fuel pump to prevent dust from entering it.

ADJUSTING CLUTCH PEDAL(U1)



(1) Clutch rod (a) free Travel

Proper clutch pedal free travel (A)	20 ~ 30 mm (0.8 ~ 1.2 in.) on the pedal
--	---

1. stop the engine and remove the key.
2. slightly depress the clutch pedal and measure free travel at top of pedal stroke.
3. If adjustment is needed, loosen the lock nut, remove the clevis pin and adjust the rod length within acceptable limits.
4. retighten the lock nut and replace the clevis pin.

ADJUSTING FAN BELT TENSION(v)

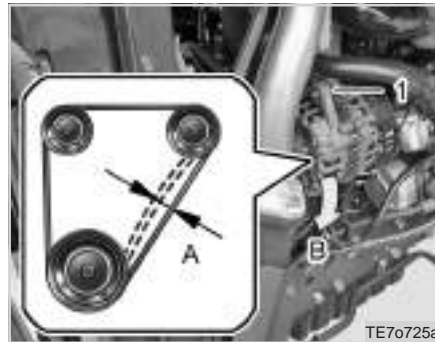

(1) adjusting bolt
(a) adjusting belt Tension (b) Pull

In order to extend the fan belt's lifetime, the tension of the belt should be correctly adjusted if it slips. The belt tension should be inspected regularly according to the following procedure:

1. stop the engine and apply the parking brake.
2. open the hood and remove the left side cover.
3. remove the mounting bolts and adjusting bolt of the alternator.

4. In order to set the belt tight, move the upper part of the alternator backward.
5. apply moderate thumb pressure to the belt between pulleys.

Proper fan belt tension (A)

A deflection between 0.28 ~ 0.35 in. (7 ~ 9 mm) when the belt is pressed in the middle of the span.

6. If tension is incorrect, loosen the alternator mounting bolts and, using a lever placed between the alternator and the engine block, pull the alternator out until the deflection of the belts falls within acceptable limits.
7. replace the fan belt if it is damaged or cracked.

CAUTION

To avoid personal injury:

- Be sure to stop the engine before checking belt tension.

BATTERY(W) PRECAUTIONS FOR HANDLING

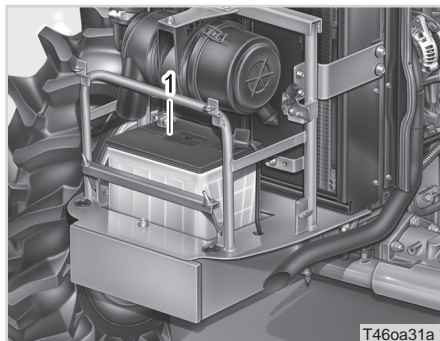

(1) battery

It is important to inspect the battery periodically.

1. The battery cable should always be clean and firmly connected. When installing a new or used battery, clean its terminals.
2. Check the battery and cable for damage and corrosion.
3. apply grease to the terminals and cable end in order to prevent corrosion.

⚠ WARNING

- *The battery gas can explode. Do not expose the battery to flames or sparks. It may cause a fire.*
- *The battery fluid contains sulfuric acid that can burn you. Do not allow the battery fluid to contact your eyes, skin, or painted surfaces. If you accidentally get it in your eyes or on your skin, flush with water and seek immediate medical attention.*
- *Be sure to wear eye protection while working on the battery. The battery fluid can hurt your eyes.*
- *Use only the battery with the specified voltage. Otherwise, it may cause a fire.*

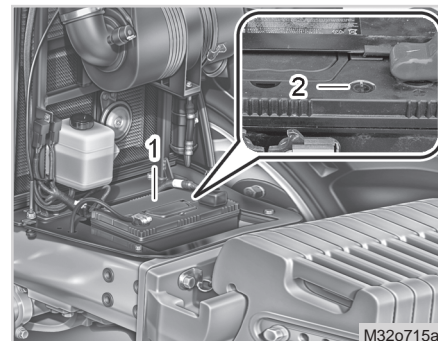

BATTERY INSPECTION



(1) battery

(2) sight Glass

Check the battery sight glass frequently to keep the battery in the best condition.

-  Green: battery normally charged
-  black: battery discharged, immediate charge required
-  White: battery replacement required

CHARGING

Contact the battery dealer for proper charging instruction.

CAUTION

- **The charge warning lamp comes on if the charging system is defective. If it comes on while driving, have the system checked or repaired by your local KIOTI Dealer.**
- **Keep the battery fully charged. If the battery fluid concentration is too low during the winter season, the battery may be frozen.**
- **Do not start the engine when the battery is frozen. Try to warm it up first.**
- **If the battery is not securely installed, the battery case and electrolytes could be damaged by vibration. To prevent the battery acid from contacting the terminals, apply grease around the battery terminals and connections.**

CAUTION

- **Never check the charge status of the battery by placing a metal object across the posts. Use a voltmeter or hydrometer.**

DIRECTION FOR STORAGE

1. When storing the tractor for a long period, remove the battery from tractor, store in a dry place out of direct sunlight.
2. The battery self-discharges while it is stored. recharge it once every three months in hot seasons and once every six months in cold seasons.

CHECKING INTAKE AIR LINE (x)



(1) air line hose

1. If the hose clamps are loose, tighten clamps securely.
2. If the hoses and clamps are damaged, you must replace them at once. failure to do so could lead to engine damage.

ADJUSTING TOE-IN(Y) ADJUSTING PROCEDURE

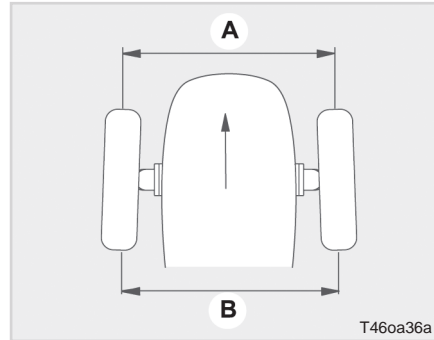

- (a) Wheel - to - wheel distance at front
(b) Wheel - to - wheel distance at rear

1. Park tractor on a flat place
2. Turn steering wheel so front wheels are pointed straight ahead.
3. lower the implement, lock the parking brake and stop the engine.
4. Measure distance between tire beads (center) at front of tire and hub height.
5. Measure distance between tire beads at the rear of tire and hub height.

6. front distance should be 0.08~0.31 in. (2~8mm) less than rear distance. If not, adjust ball joint length



READJUSTmENT

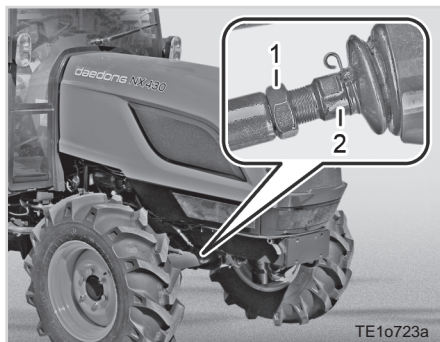

(1) lock nuts (2) Tie rod

1. loosen the lock nut and turn the turnbuckle to adjust the rod length until the proper toe-in measurement is obtained.
2. Check the toe-in value after the tie rod is adjusted.
3. adjust it again if necessary.

CHECKING RADIATOR HOSE AND CLAMP(Z)

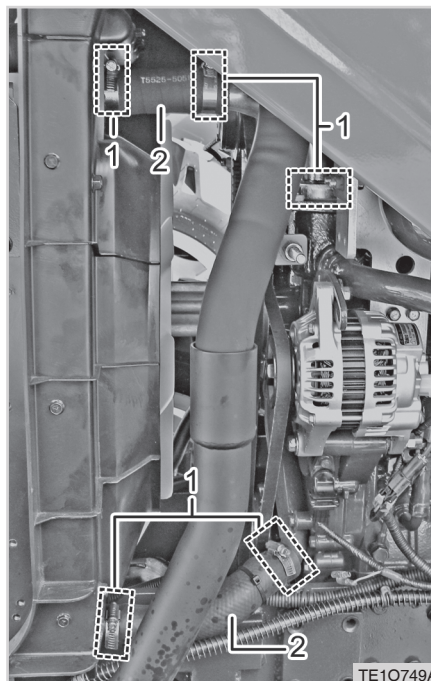

(1) radiator hose (2) Clamp

Check to ensure the radiator hoses are free from damage and are tightened properly every 200 hours or every 6 months, whichever comes first.

1. If the hose clamps are loose or water leaks from hose, tighten clamps securely.
2. If the radiator hoses are swollen, hardened, cracked, or otherwise damaged, you must replace the hoses. failure to do so could lead to coolant loss and engine damage. never perform work while engine is hot.



PRECAUTION AT OVERHEATING

Take the following actions in the event the coolant temperature reaches the boiling point, what is called "over-heating".

1. stop the machine in a safe place and keep the engine idling.
2. after 5 minutes of unloaded idling, shut the engine down.
3. Keep yourself away from the tractor for another 10 minutes or until steam has stopped blowing out of the engine.
4. Make sure that there is not danger and repair the cause of the overheating according to the manual's instruction. (Make sure to refer to "Engine troubleshooting" in chapter 8 before starting the engine)

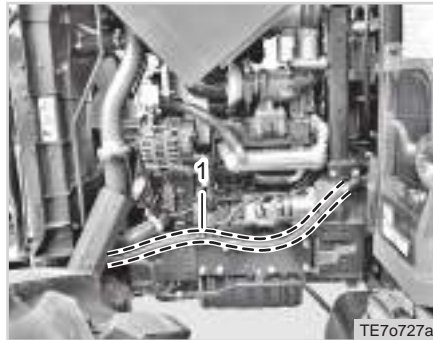
POWER STEERING LINE(AA)

(1) Power steering oil line

1. Check to see that all hydraulic lines and hose fittings are tight and undamaged.
2. If damage is found you should replace the hose at once.

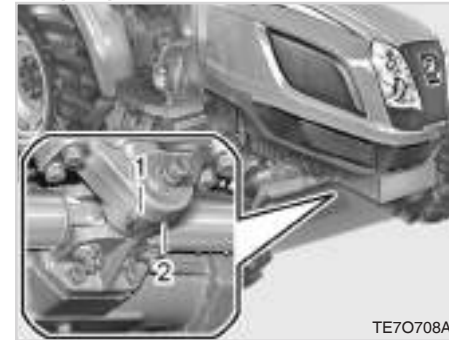
ADJUSTING FRONT AXLE PIVOT(AD)

(1) lock nut

(2) adjusting screw

If the front axle pivot pin adjustment is not correct, front wheel vibration can occur causing vibration in the steering wheel

ADJUSTING PROCEDURE

loosen the lock nut, tighten the adjusting screw all the way, and then loosen the screw by 1/6 turn. re-tighten the lock nut.

ADJUSTING ENGINE VALVE CLEARANCE(AE)

This service can be affected by the engine sensitively. Therefore, contact your local **KIOTI** Dealer for this service.

REPLACING AIR CLEANER FILTER (AF)



(1) filter
(2) Cap
(3) Evacuator valve

If the air cleaner is not in good condition, the lifetime of the engine can be shortened, excessive soot can be produced, and the engine power can be deteriorated. Therefore, the filter should be inspected frequently. Its replacement interval can be changed according to driving conditions. replace the filter according to the following procedure:

1. open the hood and check the suction hose and air cleaner housing for damage.

2. unscrew the air cleaner clip and remove the cover.
3. Clean the inside of the air cleaner housing by blowing compressed air through it.
4. replace the filter and check the housing for damage.
5. Install the cover and fix it with the clip.

NOTE

- When installing the cover, make sure that the dust collection valve is heading down.

CAUTION

- **Use only a genuine KIOTI filter. Use of a non-recommended filter can cause damage to the engine and sensor.**
- **make sure that no dust enters the system by installing the cover firmly.**
- **When removing the filter, be careful not to let foreign material enter the air inlet.**

FLUSH COOLING SYSTEM AND CHANGING COOLANT(AJ)

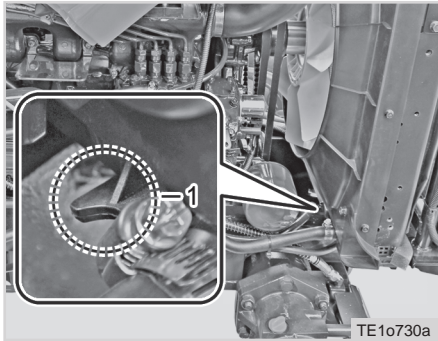

(1) Drain Cock

1. Check to see that all hydraulic lines and hose fittings are tight and undamaged.
2. If damage is found you should replace the hose at once.

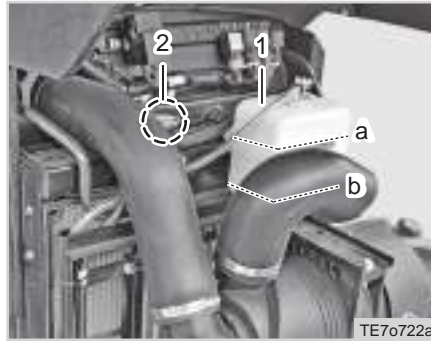

(1) reservoir Tank (2) radiator Cap
(a) full (b) loW

6. add water only up to the "loW " mark or higher level of the reservoir tank.
7. start and operate the engine for few minutes.
8. stop the engine and let it cool.
9. Check coolant level of reservoir tank and radiator. add coolant if necessary.

Coolant capacity

7.7 l (2.03 u.s.gal.)

⚠ CAUTION

To avoid accidents :

- Do not remove the radiator cap while the coolant is hot. You can get burnt by hot steam. make sure to remove it after the coolant is cooled down enough.
- Even though the coolant is cooled down, turn the cap to its first stop and then wait until it is depressurized before removing the cap completely.

ANTIFREEZE(AK)

⊕ IMPORTANT

- Do not start engine without coolant.
- Use clean, fresh water and anti-freeze to fill the radiator and reservoir tank.
- When the anti-freeze is mixed with water, the anti-freeze mixing ratio must be no less than 50% mixture of water and anti-freeze.
- Securely tighten radiator cap.
- If the cap is loose or improperly fitted, water may leak out and the engine could over-heat.
- If the radiator cap has to be removed, follow the caution above and securely retighten the cap.
- If the coolant leaks, contact your local KIOTI Dealer.

This tractor is filled with 50% of ethylene glycol at factory.

If the antifreeze has been replaced by tap water later on, the coolant can be frozen, leading to damage to the cylinder and radiator when the ambient temperature is below 0°.

Therefore, make sure to change water into antifreeze before winter season comes.

When changing the antifreeze with one of another type, flush the cooling system several times and contact a professional for the mixture ratio.

vol. % Antifreeze	Freezing Point		Boiling Point	
	°F	°C	°F	°C
40	-12	-24	222	106
50	-34	-37	226	108

* at 760 mmhg pressure. (atmospheric)
a higher boiling point is obtained by using a radiator pressure cap.

📖 NOTE

- The temperatures shown on the left are industry standards that necessitate a minimum glycol content in the concentrated anti-freeze.
- When the coolant level drops due to evaporation, add water only. In case of leakage, add anti-freeze and water in the specified mixing ratio.
- antifreeze absorbs moisture. Keep unused antifreeze in a tightly sealed container.
- Do not use radiator cleaning agents when antifreeze has been added to the cooling water. (antifreeze contains an anti-corrosive agent, which will react with the radiator cleaning agent forming sludge which will affect the engine parts)

DRAINING WATER FROM CLUTCH HOUSING(AL)



(1) Plug

1. There is a plug under the clutch housing.
2. Drain the water completely and install the plug. Drain the water into a container and dispose of it in a proper manner for environment protection.

BLEEDING FUEL SYSTEM(Am)

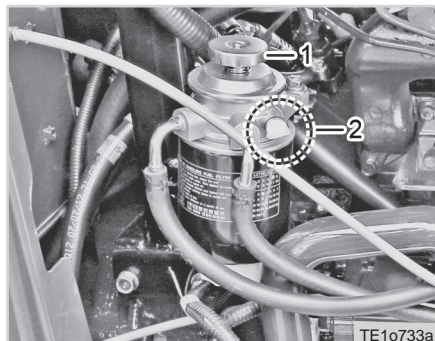

(1) Pump

(2) air Plug

1. Make sure that the amount of fuel in the fuel tank is sufficient.
2. If there is air in the fuel filter, turn the filter cock to the air side and turn the ignition key to turn the start motor. Then, the air in the filter port is discharged through the bleeding hose as shown in the figure.

⚠ CAUTION

- Do not operate the start motor for more than 5 seconds continuously. Instead, operate it for several times within 5 seconds each time.

📖 NOTE

- It is not necessary to bleed the system if filling the tank with fuel before installing the fuel port.

3. When fuel is visible through the bleeding bolt, tighten the bolt and start the engine.

⊕ IMPORTANT

To protect the catalyst filter, keep the followings:

- make sure to use only genuine fuel.
- Keep the engine oil replacement schedule.
- Check the engine oil level frequently to keep it to the specified level.
- Avoid any unnecessary engine idling.
- Never stop the engine during driving.
- Never place the shift lever in the neutral position when driving downhill.
- Do not use any engine oil additive or fuel additive.
- Avoid driving with any warning lamp illuminated.
- Do not allow any flammable materials, such as dry grass and paper, to come near the catalyst filter while parked.

⚠ CAUTION

- Never bleed the fuel system while the engine is hot.

⊕ IMPORTANT

- After bleeding, fuel without air bubbles is filtered by the fuel filter and is transferred to the fuel injection pump. Maintain the proper fuel level in the fuel tank before the fuel tank becomes empty. If all fuel is completely consumed in a Diesel engine, fuel should be added to the fuel tank and then the fuel system should be bled.

📖 NOTE

- If the engine cannot be started even after bleeding the fuel system, contact your local Dealer.

REPLACING FUSE(AN)

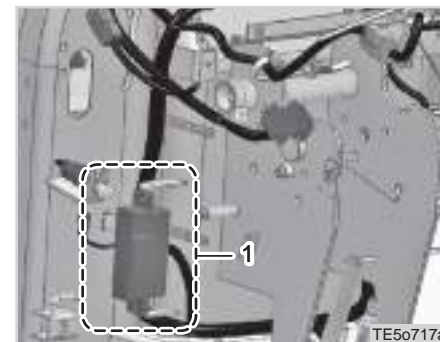

(1) fuse box

fuses protect the tractor electrical system from potential damage. a blown fuse indicates that there is an overload or short somewhere in the electrical system.

[MANUAL]

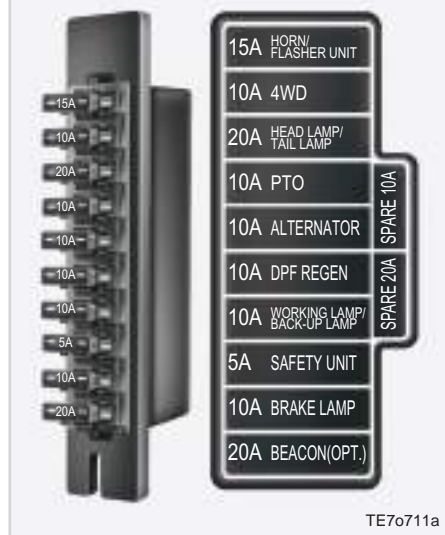

[HST]



(1) fuse storage Case

(2) fuse

There are marks for the fuse capacity and location on the cover of the fuse panel. replace the fuse according to the following procedure :

1. Turn the key switch to the "off " position and turn off all the electrical devices.
2. open the fuse box cover and check the fuse in question using fuse tongs.

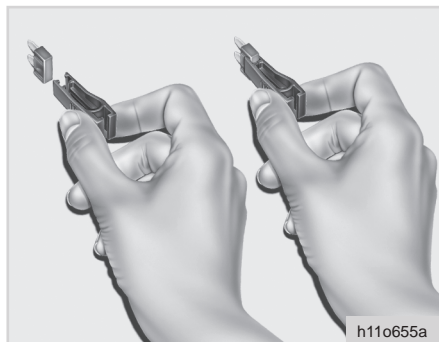

h11o655a

3. If the fuse is blown, replace it with a new fuse with same capacity. Make sure it is firmly installed.
4. Install the fuse box cover.

! WARNING

- *Never use a fuse with the capacity higher than specified on the fuse box cover.*
- *If using a faulty fuse, steel wire, or foil, the electrical device can be damaged or even catch a fire.*

NOTE

- If the replaced fuse is blown soon, it is probable that the wiring system is faulty. In this case, contact your local **KIOTI** Dealer.
- If the fusible link, relay or other electrical component is faulty, contact your local **KIOTI** Dealer.

SLOW BLOW FUSE(AP)

TE7o723a

(1) slow blow fuse

The slow-blow fuse is to protect the electric wiring. If it is blown, find and repair the cause and replace it with a new genuine part.

Slow Blow Fuse

60a

7

⊕ IMPORTANT

- Using a non-approved slow-blow fuse can damage electrical systems in the tractor severely.
- Refer to the chapter "Troubleshooting" in this manual or contact your local KIOTI Dealer for specific information dealing with electrical problems.

REPLACING BULB(AQ)

The bulb and capacity used in this tractor are listed in the below table. This section only describes procedures the users can handle.

No.	Bulb		Capacity
1	headlamp		55W/60W
2	stop/Position lamp (rear)		21W/5W
3	Turn signal lamp		21W
4	Work lamp		21W
5	Cluster	Charging warning light	3W
	Indicator	others	1.4W

HEADLAMP



(1) opening Knob

(2) hood

(a) Pull

1. Turn the key switch to the "off" position and open the hood.



(1) Cap

(2) Connector

- remove the cap.
- Press and turn the socket counterclockwise to remove the bulb. If the bulb is blown, replace it with a new bulb with the same capacity.

⚠ WARNING

- *If using a bulb other than the specified one, the lamp can be damaged and the tractor can even catch fire.*
- *make sure to use bulbs with the specified capacity.*

⚠ CAUTION

- **make sure to use a KIOTI genuine bulb. Using a non-recommended bulb can cause a fire.**
- **The headlamps can temporarily be fogged due to rain or car wash. This is because of the temperature difference between the inside and outside of the lamp, which is normal.**



mEmO





STORAGE AND DISPOSAL

TRACTOR STORAGE	8-2
Daily sToraGE	8-2
lonG-TErM sToraGE	8-2
USING TRACTOR AFTER STORAGE	8-4
USAGE AND DISPOSAL.....	8-4

8

8

TRACTOR STORAGE

DAILY STORAGE

1. Keep the tractor clean when it is stored. Make sure to wash it after work.
2. store it indoors if possible. If it should be kept outside, cover it.

WARNING

- *When operating the tractor in an enclosed area, ventilate the area to release exhaust gas to the outside. The exhaust gas is colorless and not visible, but is harmful.*

3. remove the battery from the tractor in winter and store it indoors.
4. add anti-freeze to the tractor in winter season in order to prevent the radiator from freezing.
5. remove the ignition key and store it separately.

LONG-TERM STORAGE

follow the instructions below if the tractor is not to be used for a long period of time. This is to operate the tractor again with minimum preparation after long-term storage. repeat this procedure if the tractor hasn't been used for one year.

IMPORTANT

- **If the tractor is not used for an extended period of time, follow the instructions below to prevent corrosion and performance deterioration of the tractor while it is stored.**

1. Check the bolts and nuts for looseness, and tighten if necessary.
2. apply grease to tractor areas where bare metal will rust also to pivot areas.
3. Detach the weights from the tractor body.
4. Inflate the tires to a pressure a little higher than usual.

5. Change the engine oil and run the engine to circulate oil throughout the engine parts all for about 5 minutes.
13. set all control systems neutral.
14. Plug any open exhaust pipes.
15. attach a tag onto the tractor to inform the storage condition of the tractor.
16. Interlock the brake pedals and apply the parking brake.



(1) latch (a) Depress
(2) Clutch Pedal (b) hook to lock

6. With all implements lowered to the ground, coat any exposed area such as hydraulic cylinder piston rods with grease.
7. remove the battery from the tractor. store the battery following the battery storage procedures.
8. Keep the tractor in a dry place where the tractor is sheltered from rain. Cover the tractor.

9. Clean the engine components as well as the tractor.
10. Add grease to all the grease fitting.
11. flush the cooling system and drain water from it. also, add antifreeze as well as water.
12. Chock the frame in order to remove the weight from the tires.

CAUTION

To avoid injury :

- **Never clean the tractor body while the engine is running.**
- **Never run the engine in an enclosed area without proper ventilation system in order to prevent poisoning by exhaust gas.**
- **When storing the tractor, remove the key from the switch and store it separately in order to prevent an unauthorized person from operating the tractor and being injured.**
- **Cover the tractor after the muffler and the engine have cooled down.**
- **If the battery is not to be removed, disconnect its negative terminal at least. The wiring can be gnawed by rodents, leading to a fire.**

USING TRACTOR AFTER STORAGE

1. Check the tire air pressure and inflate the tires if they are low.
2. Install a fully charged battery.
3. Check the fan belt tension.
4. Check all fluid levels. (Engine oil, transmission/hydraulic oil, engine coolant and any attached implements)
5. Check the urea level in the tank and add urea as necessary.
6. remove grease from the exposed cylinder rod.
7. apply grease to the lubrication points.
8. remove the cover from the exhaust pipe.
9. Get onto the tractor and start the engine.
10. Check if the instrument panel and all parts operate correctly while running the engine for a few minutes.
11. Drive the tractor outside and check if it is operating properly. Park the tractor outside and idle engine for at least 5 minutes. stop the engine and visually inspect the tractor. Check if there is leakage.
12. start the engine, release the parking brake, and check the brake condition while driving forward. adjust the brake pedals if necessary.
13. stop the engine and check for leakage. repair any part as required.

USAGE AND DISPOSAL

In order to protect the environment, use and dispose of the tractor keeping the following in mind :

1. When changing the oil or coolant by yourself, be careful not to spill it and dispose used oil and coolant properly according to the applicable regulations.
2. never leave or discard the expired tractor or implement, but contact your local **KIOTI** Dealer to dispose it according to the regulations.
3. avoid working under high load as it can cause excessive exhaust gas, which is harmful to the environment.



TROUBLESHOOTING

ENGINE TROUBLESHOOTING 9-2

TRACTOR TROUBLESHOOTING 9-4

9

9



This troubleshooting chart summarizes simple service items for users who are familiar with mechanical systems. For more detailed service items, contact your local **KIOTI** Dealer.

ENGINE TROUBLESHOOTING

CAUSE		COUNTERMEASURES
1. When engine is difficult to start	• Fuel is thick and doesn't flow.	• Check the fuel tank and fuel filter.
		• Remove water, dirt and other impurities.
		• As all fuel will be filtered by the filter, if there should be water or other foreign matters on the filter, replace the filter.
	• Air or water mixed in fuel system.	• If air is in the fuel filter or injection lines, the fuel pump will not work properly.
		• To attain proper fuel injection pressure, check carefully for loosened fuel cap nut, etc.
		• Loosen air vent screw over fuel filter and fuel injection pump to eliminate all the air in the fuel system.
	• Thick carbon deposits on orifice of injection nozzle.	• This is caused when water or dirt is mixed in the fuel. Clean the nozzle injection piece, being careful not to damage the orifice.
		• Check to see if nozzle is working properly or not, if not, install a new nozzle.
	• Valve clearance is wrong.	• Adjust valve clearance (when the engine is cold) • Contact to KIOTI dealer.
	• Engine oil become thick in cold weather and engine cranks slow.	• Change grade of oil according to the weather (temperature).

CAUSE		COUNTERMEASURES						
1. When engine is difficult to start	<ul style="list-style-type: none"> Start motor does not rotate when key switch is turned 	<ul style="list-style-type: none"> Depress the clutch pedal unless depressed. (Manual type) 						
		<ul style="list-style-type: none"> Put the PTO switch to the OFF position. 						
		<ul style="list-style-type: none"> If the switch or start motor is faulty, have it repaired in a workshop. 						
		<ul style="list-style-type: none"> If any terminal is loose or corroded, clean or fix it firmly. 						
2. When output is insufficient	<ul style="list-style-type: none"> Valve out of adjustment 	<ul style="list-style-type: none"> Adjust to proper valve clearance. Contact to KIOTI dealer. 						
	<ul style="list-style-type: none"> Air cleaner is dirty 	<ul style="list-style-type: none"> Clean or replace the element at every 100 to 200 hours of operation. 						
	<ul style="list-style-type: none"> Fuel injection pressure is wrong 	<ul style="list-style-type: none"> Adjust it to 150 to 160 kgf/cm² or replace the injection nozzle. 						
3. When color of exhaust is specially bad	<ul style="list-style-type: none"> Fuel is of extremely poor quality 	<ul style="list-style-type: none"> Select good quality fuel. <table border="0" style="margin-left: 20px;"> <tr> <td>Temperature</td> <td>Fuel type</td> </tr> <tr> <td>- Above -10°C (14°F)</td> <td>NO.2 Diesel</td> </tr> <tr> <td>- Below -10°C (14°F)</td> <td>NO.1 Diesel</td> </tr> </table> 	Temperature	Fuel type	- Above -10°C (14°F)	NO.2 Diesel	- Below -10°C (14°F)	NO.1 Diesel
	Temperature	Fuel type						
- Above -10°C (14°F)	NO.2 Diesel							
- Below -10°C (14°F)	NO.1 Diesel							
<ul style="list-style-type: none"> Nozzle is bad 	<ul style="list-style-type: none"> If necessary, replace with new nozzle. 							

※ If you do not find the cause of trouble, consult your dealer for assistance.

TRACTOR TROUBLESHOOTING

CAUSE		COUNTERMEASURES
1. When tractor does not move while engine is running	• Shift lever is in neutral position	• Check the shift levers.
	• Parking brake is applied	• Release the parking brake.
2. Clutch is not operating properly	• Clutch slips (Idles)	• Contact KIOTI dealer.
	• Clutch cannot be disengaged	
3. Brake is not operating properly	• Brake does not operate or only one brake pedal operates	• The brake pedal play is excessive. Adjust the play.
	• Brake pedal does not return properly	• The brake lining is worn or stuck. Have it replaced in a workshop.
		• The brake return spring is damaged. Replace it.
4. Steering wheel is not operating properly	• Steering wheel is heavy or vibrate	• Grease is insufficient on each mating surface. Remove rust and apply grease.
		• The toe-in is incorrect. Adjust it again.
		• The tire inflation pressure is different. Inflate the left and right tires into the specified pressure.
	• Steering wheel play is excessive	• Each connection is loose. Re-tighten each connection and replace the part.
		• The steering wheel shaft is worn. Have it repaired in a workshop. Metal parts are worn. Have them repaired in a workshop. Each connection has play. Tighten the connection again.
5. Hydraulic system is faulty	• Oil is leaked from pipe or hose	• The pipe clamp is loose. Re-tighten it.
	• 3-point hitch cannot be lowered	• The pipe is cracked. Have it repaired in a workshop.
		• Set the lowering speed control knob to open if it is set to the stop position.
		• The valve and cylinder are damaged. Have them repaired in a workshop.

CAUSE	COUNTERmeASURES	
5. Hydraulic system is faulty	<ul style="list-style-type: none"> • 3-point hitch cannot be lifted 	<ul style="list-style-type: none"> • The transmission fluid is insufficient. Add it to the specified level.
	<ul style="list-style-type: none"> • There is air in the intake pipe. Bleed the pipe. 	<ul style="list-style-type: none"> • The oil filter is clogged. Replace it.
	<ul style="list-style-type: none"> • The hydraulic filter, valve and cylinder are malfunctioning. Have them repaired in a workshop. 	<ul style="list-style-type: none"> • The hydraulic filter, valve and cylinder are malfunctioning. Have them repaired in a workshop.
	<ul style="list-style-type: none"> • 3-point hitch vibrates by itself 	<ul style="list-style-type: none"> • Set the draft control lever to the "Deep" position.
	<ul style="list-style-type: none"> • Select the highest top link hole. 	<ul style="list-style-type: none"> • Select the highest top link hole.
6. Electric system is faulty	<ul style="list-style-type: none"> • Headlamps cannot be turned on or are dim. 	<ul style="list-style-type: none"> • The fuse is blown. Check the wiring and replace the fuse.
	<ul style="list-style-type: none"> • The bulb is blown. Replace it 	<ul style="list-style-type: none"> • The bulb is blown. Replace it
	<ul style="list-style-type: none"> • The ground and terminal wirings are poorly contacted. Check and clean them. 	<ul style="list-style-type: none"> • The ground and terminal wirings are poorly contacted. Check and clean them.
	<ul style="list-style-type: none"> • The battery electrolyte level is low. Charge the battery. 	<ul style="list-style-type: none"> • The battery electrolyte level is low. Charge the battery.
<ul style="list-style-type: none"> • Battery cannot be charged 	<ul style="list-style-type: none"> • Check the battery and alternator. 	<ul style="list-style-type: none"> • Check the battery and alternator.
<ul style="list-style-type: none"> • Horn does not sound 	<ul style="list-style-type: none"> • The horn switch is faulty. Replace or see KIOTI dealer. 	<ul style="list-style-type: none"> • The horn switch is faulty. Replace or see KIOTI dealer.
	<ul style="list-style-type: none"> • The wiring is faulty. Replace or See KIOTI dealer. 	<ul style="list-style-type: none"> • The wiring is faulty. Replace or See KIOTI dealer.
	<ul style="list-style-type: none"> • The horn is damaged. Repair or replace it. 	<ul style="list-style-type: none"> • The horn is damaged. Repair or replace it.
<ul style="list-style-type: none"> • Turn signal lamps do not blink 	<ul style="list-style-type: none"> • The bulb is blown. Replace it. 	<ul style="list-style-type: none"> • The bulb is blown. Replace it.
	<ul style="list-style-type: none"> • The blinking device is faulty. Repair or replace it. 	<ul style="list-style-type: none"> • The blinking device is faulty. Repair or replace it.
	<ul style="list-style-type: none"> • The ground and terminal wirings are poorly contacted. Check and clean them. 	<ul style="list-style-type: none"> • The ground and terminal wirings are poorly contacted. Check and clean them.

CAUSE		COUNTERmEASURES
6. Electric system is faulty	<ul style="list-style-type: none"> • Work lamps do not come on 	<ul style="list-style-type: none"> • The bulb is blown. Replace it. • The ground and terminal wirings are poorly contacted. Check and clean them.

※ If you do not find the cause of trouble, consult your dealer for assistance.



INDEX

INDEX..... 10-2

10

10



NUMERIC

3-Point hITCh ConTrol sYsTEM	5-23
4WD InDICaTor	4-19
4WD sWITCh	4-9
7-Pln PoWEr ouTPuT soCKET (oPTIon)	4-38

A

aDDITioNal fronT WEIGHt	4-43
aDDITioNal IIQuID TYPE WEIGHt	4-45
aDDITioNal rEar WEIGHt	4-44
aDDITioNal WEIGHt(oPTIonal)	4-43
aDjusTInG braKE PEDal(o)	7-18
aDjusTInG CluTCh PEDal(u1)	7-23
aDjusTInG EnGInE val vE ClEaranCE(aE)	7-29
aDjusTInG fan bEIT TEEnson(v).....	7-23
aDjusTInG fronT axIE PlvoT(aD).....	7-28
aDjusTInG ProCEDurE	7-26
aDjusTInG T oE-In(Y)	7-26
aDjusTMEnT of lIfT roD	6-5
aDjusTMEnT of sTablllZEr	6-7
aDjusTMEnT of ToP lInK	6-6
anTIfrEEzE(aK)	7-31

B

baTTErY CharGInG laMP	4-17
baTTErY InsPECTIon	7-24
baTTErY(W)	7-24
bEITs anD rubbEr ParTs	2-4
bIEEDInG fuEl sYsTEM(aM).....	7-32
braKE (onE sIDe) laMP	4-19
braKE PEDal	4-29
braKE PEDal frEE PlaY	7-18

C

CauTions for DECal MaInTENanCE	1-28
ChanGInG EnGInE oll anD rEPlaCInG flITer(l)...	7-13
ChanGInG fronT axIE CasE oll(n)	7-17
CharGInG	7-25
ChECKInG anD aDDInG fuEl(C)	7-8
ChECKInG braKE PEDals(h)	7-12
ChECKInG CoolanT IEvEl(f)	7-11
ChECKInG EnGInE oll IEvEl(E)	7-10
ChECKInG fuEl lInEs (u)	7-22
ChECKInG GauGEs, METEr anD EasY ChECKEr (l) ...	7-13
ChECKInG hEaD lIGHt, hazarD lIGHt ETC. (j)	7-13
ChECKInG InTaKE alr lInE (x)	7-26
ChECKInG raDIaTor hosE anD ClAMP(z)	7-27



ChECKInG sEaT bEIT and CabIn (K)..... 7-13
 ChECKInG TransMIssIon fluid IEvEI(D)..... 7-9
 ChECKInG WhEEl boIT / nuT TorQuE(Q)..... 7-20
 CIeanInG Grill, raDIaTor sCrEEen(G) 7-12
 CIeanInG ThE TraCTor..... 1-24
 CluTCh PEDal4-28
 CoMblnaTIon sWITCh4-7
 CoMPonEnTs for aDDITIoNal fronT WEIGHt4-44
 ConnECTInG and DIscConnECTInG IMPIEMEnT
 hYDraulIC hose5-29
 CruIsE laMP (If EquIPPED)4-23
 CruIsE PTo laMP4-23
 CushIon sTrEnGTh aDjusTMEnT4-35

D

DaIlY ChECK ITEM 7-3
 DaIlY sToraGE 8-2
 DECal MounTInG loCaTIon..... 1-25
 DEcals 1-26
 DEsCrIPTIon of oPEraTInG sYsTEM4-1
 DIaGnosTIC TroublE CoDE(DTC).....4-24
 DIffErEnTIAL loCK PEDal4-33
 DIrECTIon for sToraGE..... 7-25
 Double aCTInG IEvEr4-37

Double aCTInG val vE IEvEr5-27
 DPf rEGEnEraTIon sWITCh4-12
 DPf rEGEnEraTIon W arnInG laMP4-21
 DraFT ConTrol5-25
 DraFT ConTrol IEvEr 4-36
 DraFT hITCh and TralIEr 6-7
 DralnInG W aTEr from CluTCh housInG(al)7-32
 DrIvInG on DoWnhIll 6-13
 DrIvInG on sloPE5-18
 DrIvInG on sloPE6-13
 DrIvInG on uPhIll 6-13

E

EnGInE ChECK W arnInG laMP4-20
 EnGInE CoolanT TEMPEraTurE GauGE4-15
 EnGInE nuMbEr2-2
 EnGInE oil PrEssurE W arnInG laMP4-16
 EnGInE TroublEshooTInG..... 9-2
 Error InDICaTor4-24
 EssEnTIAL rEPlaCEMenT PaRT2-3
 EvaCuaTor val vE..... 7-22
 ExTErIor hYDraulIC ConTrol sYsTEM5-27
 ExTErIor vIEW4-3
 ExTErnal DIMEnslons 3-2



F		
flITers	2-4	
flxaTlon PolnTs for front EnD loaDER	6-12	
flush CoolInG sYsTEM anD ChanGInG Cool- anT(aj)	7-30	
fooT ThroTTIE	4-31	
front anD rEar WhEEl boIT anD nuT TorQuE	4-42	
front/rEar WhEEl InsTallaTlon PaTTErn	4-41	
fuEl flITer (s).....	7-20	
fuEl GauGE	4-15	
G		
GEnEral PrECauTions	1-2	
GEnEral sPECIfiCaTions.....	3-2	
GEnEral sPECIfiCaTions.....	3-3	
GEnEral TlrE InforMaTlon	4-39	
GloW PluG laMP	4-18	
H		
hanD ThroTTIE IEvEr	4-32	
hanDInG loaDER	6-11	
hazarD laMP sWITCh.....	4-9	
hEaD lIGHt hIGH bEaM laMP	4-17	
hEaD lIGHt sWITCh.....	4-7	
hEaDlaMP	7-36	
horn sWITCh.....	4-8	
hoW To DrIvE.....	5-11	
hoW T o foLD ThE roPs.....	5-14	
hoW To oPEn ThE hooD(a).....	7-8	
hoW To ralsE ThE roPs To uPrIGHt PosITlon	5-15	
hYDraulIC bloCK.....	6-15	
I		
IDEnTifiCaTlon & InTroDuCTlon of W arranTY	2-1	
IMPIEMEnT lIMITaTions.....	3-8	
IMPIEMEnTs anD aTTaChMEnTs	1-21	
InDEx.....	10-1	
InflaTlon PrEssurE	4-40	
InITlal oPEraTlon	5-3	
InsTallInG PTo shaft	6-9	
InsTruMEnT PanEl	4-14	
J		
joYsTICK v al vE PorT	6-14	
juMP sTarTInG.....	5-10	
K		
KEY sWITCh	4-6	



L

lIfTInG arM (loWEr lInK) sPEED ConTrol Knob4-37

lInKED PEDal laMP4-23

lInKED PEDal IEvEr 4-32

loaDInG InTo and unloaDInG ouT of ThE TruCK ..5-20

lonG-TErM sToraGE 8-2

lubriCanTs..... 7-7

lubriCaTInG GrEasE loCaTlons(P)7-19

m

MaIn shIfT IEvEr 4-27

MaInTEnanCE 7-1

MaInTEnanCE ChECK lIsT7-3

MaInTEnanCE CoDE7-8

MaInTEnanCE sChEDulE CharT7-4

MounTInG loCaTlon..... 4-5

O

ollS and fluIDs 2-3

oPEraTInG ThE ConTrols 4-25

oPEraTInG ThE EnGInE..... 5-3

oPEraTInG ThE TraCTor 5-11

oPEraTlon..... 5-1

oPEraTlon TIP for 3-PoInT hITCh ElEMEnTs..... 6-5

oThEr CoMPonEnTs2-4

P

ParKInG5-16

ParKInG braKE IEvEr 4-30

ParKInG braKE laMP4-18

ParKInG WITH loaDEr InsTalleD 6-14

PosITlon ConTrol IEvEr4-36

POWEr sTEERInG lInE(aa)7-28

PrECauTlon aT ovErhEaTInG..... 7-28

PrECauTlon for InsTallInG hoW To usE ToP
lInK holEs..... 6-6

PrECauTlons bEforE oPEraTlon..... 1-2

PrECauTlons DurInG oPEraTlon 1-8

PrECauTlons for hanDlInG 7-24

PrECauTlons WhEn usInG POWEr sTEERInG5-21

PrECauTlons WhIlE DrIvInG on ThE roaD 5-20

PrE-oPEraTlon5-2

ProDuCTlon nuMbEr..... 2-2

PT1/2 CouPIEr soCKET (IMPIEMEnT) 5-29

PTo CluTCh sWITCh 4-11

PTo InDICaTor..... 4-18

PTo sETTInG sWITCh4-10

PTo shIEID and shafT CaP4-12

R

ranGE GEAr shIfT IEvEr	4-27
rEaDjusTMEnT	7-27
rEar PTo sWITCh	4-10
rEGEnEraTion unDEr WaY laMP	4-20
rEGEnEraTion WarnInG laMP	4-20
rEMov al anD InsTallaTion of 3-PolnT hITCh IMPIEMEnT (WITh PTo shaft)	6-2
rEMovInG W aTEr froM fuEl fIlTEr	7-20
rEPlaCInG alr ClEanEr fIlTEr (af)	7-29
rEPlaCInG alr ClEanEr PrImaRY EIEMEnT(T)	7-21
rEPlaCInG bulb(aQ).....	7-36
rEPlaCInG fuEl fIlTEr.....	7-21
rEPlaCInG fusE(an).....	7-33
rEPlaCInG TransMIssIon fluID anD fIlTEr(M)	7-15
rIM boIT anD nuT TorQuE	4-42
rIsK of ovErTurnInG	1-5

S

safETY DECaI MaInTEnanCE.....	1-25
safETY PrECauTions	1-1
safETY PrECauTions DurInG sEr vICInG.....	1-15
safETY PrECauTions WhEn usInG ThE loadEr ..	1-19
sEaT aDjusTMEnT	4-34

sEaT bEIT	4-35
sEaT sIIDInG	4-34
shuTTIE shIfT IEvEr	4-28
sInGIE aCTInG anD Double aCTInG CYlInDER	5-28
sloW bloW fusE(aP)	7-35
sPECIfICaTions.....	3-1
sTanDarD slZE bY IMPIEMEnT	3-8
sTarTInG ThE EnGInE.....	5-3
sTEErInG WhEEl aDjusTMEnT	4-30
sToPPInG ThE EnGInE.....	5-8
sToraGE anD DisPosal	8-1
sWITCh	4-5

T

ThE CauTions WhEn CoMInG In anD ouT of PavED road.....	5-19
TIrEs, WhEEls anD ballasT	4-39
TraCTor sToraGE.....	8-2
TraCTor TroubIEshooTInG	9-4
TransMIssIon nuMbEr	2-2
Tra vEllnG sPEED	3-6
TrEaD	4-41
TroubIEshooTInG	9-1
Turn sIGnal laMP	4-17



Turn sIGnal lIGHt sWITCh..... 4-8
 TurnInG 5-18

WhEn usInG ThE 3-PoInT hITCh..... 1-15

U

usaGE and DisPosal8-4
 usInG TraCTor afTEr sToraGE..... 8-4

v

vEHICIE IDEnTIfICaTIon nuMbEr 2-2
 vIEW4-14

W

WarMInG uP5-9
 WaTEr In fuEl WarnInG laMP4-22
 WhEEl InsTallaTIon DIRECTIon4-43
 WhEEl TorQuE and DIRECTIon 4-41
 WhEn DrIvInG ThE TraCTor1-12
 WhEn loaDED buCKET and rEar ballasT arE
 InsTallED 6-13
 WhEn oPEraTIInG ThE P .T.o.1-14
 WhEn ParKInG ThE TraCTor1-13
 WhEn sTarTIInG ThE EnGInE..... 1-8
 WhEn unloADED buCKET and rEar ballasT
 arE InsTallED 6-13





 **WARNING**

Breathing diesel engine exhaust exposes you to chemicals known to the State of California to cause cancer and birth defects or other reproductive harm.

- Always start and operate the engine in a well-ventilated area.
- If in an enclosed area, vent the exhaust to the outside.
- Do not modify or tamper with the exhaust system.
- Do not idle the engine except as necessary.

For more information go to www.P65warnings.ca.gov/diesel

TD26-1009

