



## FOReWARD

Congratulations, and welcome to the world of **RX6020 / RX6620 / RX7320 / RX7620** ownership, where serious work is made fun again!

This versatile tractor is a culmination of the entire scope of tractor and diesel engine knowledge gained by the **DAe-DONG IND. Co., LTD**, since 1947 The **RX6020 / RX6620 / RX7320 / RX7620** has been designed with the finest materials, under rigid quality control standards set forth by the **KIOTI** Engineering Department.

Knowledge of tractor operation is essential for many years of dependable service and reliability. To help new owners familiarize themselves with the **KIOTI RX6020 / RX6620 / RX7320 / RX7620**, it is the policy of **KIOTI** tractor to provide an owners manual which includes helpful information about tractor safety, operation and maintenance. If the information you seek is not found in this manual, your **KIOTI** tractor dealer will be happy to help you.

Please feel free to contact **DAeDONG IND. CO.,LTD / DAeDONG-USA, INC.** with your questions/concerns.

### < NOTE >

- Make sure to read this manual carefully and keep it handy for future reference.
- When leasing or transferring this tractor, deliver this manual together with the tractor.
- The specifications in this manual are subject to change without notice.



## ISO 3600 eU STANDARDS

This manual was compiled in compliance with the ISO 3600, standards and the instructions contained here comply with the requirements of the Machinery Directive 2010/52/EU in force in the European Community. For tractors sold or used outside the European Community, local laws will prevail.

Main protections on the tractors discussed in this manual.

DeSCRIPTION	NON CANOPY	CANOPY
1. ROPS (protection against overturning)	Yes	Yes
2. FOPS (protection against objects falling from above)	No	Yes
3. OPS (protection against penetration of objects from sides) protection against hazardous chemicals	No (Category I )	No (Category I )



## TABLE OF CONTENTS

*SeCTION*

■ <b>SAFETY PRECAUTIONS .....</b>	<b>1</b>
■ <b>PRECAUTIONS BEFORE OPERATION .....</b>	<b>2</b>
■ <b>SPECIFICATIONS.....</b>	<b>3</b>
■ <b>DESCRIPTION OF OPERATING SYSTEM.....</b>	<b>4</b>
■ <b>OPERATION .....</b>	<b>5</b>
■ <b>3-POINT HITCH IMPLEMENT AND LOADER OPERATION .....</b>	<b>6</b>
■ <b>MAINTENANCE.....</b>	<b>7</b>
■ <b>STORAGE AND DISPOSAL.....</b>	<b>8</b>
■ <b>TROUBLESHOOTING.....</b>	<b>9</b>
■ <b>INDEX.....</b>	<b>10</b>





# TABLE OF CONTENTS

<b>SAFeTY PReCAUTIONS .....</b>	<b>1-1</b>	<b>vehICLe IDeNTIFICATION NUmBeR .....</b>	<b>2-2</b>
<b>PReCAUTIONS BeFORe OPeRATION .....</b>	<b>1-2</b>	TRACTOR SERIAL NUMBER .....	2-2
GENERAL PRECAUTIONS.....	1-2	ENGINE SERIAL NUMBER.....	2-2
<b>PReCAUTIONS DURING OPeRATION .....</b>	<b>1-5</b>	TRANSMISSION SERIAL NUMBER .....	2-2
WHEN STARTING THE ENGINE .....	1-5	<b>eSSeNTIAL RePLACeMeNT PARTS .....</b>	<b>2-4</b>
WHEN DRIVING THE TRACTOR .....	1-9	OILS AND FLUIDS .....	2-4
WHEN PARKING THE TRACTOR .....	1-11	FILTERS .....	2-4
WHEN OPERATING THE PTO .....	1-11	BELTS AND RUBBER PARTS.....	2-5
WHEN USING THE 3-POINT HITCH .....	1-12	OTHER COMPONENTS .....	2-5
<b>SAFeTY PReCAUTIONS DURING SeR vICING ...</b>	<b>1-12</b>	<b>SPeCIFICATIONS .....</b>	<b>3-1</b>
<b>SAFeTY PReCAUTIONS Whe N USING The LOADeR....</b>	<b>1-17</b>	<b>GeNeRAL SPeCIFICATIONS .....</b>	<b>3-2</b>
<b>SAFeTY DeCAL mAINTeNANCe .....</b>	<b>1-20</b>	EXTERNAL DIMENSIONS .....	3-2
DECAL MOUNTING LOCATION (CABIN).....	1-20	GENERAL SPECIFICATIONS .....	3-6
DECAL MOUNTING LOCATION (ROPS).....	1-22	NOISE LEVELS AS PERCEIVED BY THE OPERATOR	3-21
DECALS .....	1-24	VIBRATION LEVELS OF THE	
CAUTIONS FOR DECAL MAINTENANCE .....	1-27	TRACTOR EXPOSITION TO VIBRATIONS .....	3-22
<b>PReCAUTIONS BeFORe OPeRATION .....</b>	<b>2-1</b>	<b>TRAVeLING SPeED .....</b>	<b>3-23</b>
		<b>ImPLeMeNT LImitATIONS .....</b>	<b>3-26</b>



# TABLE OF CONTENTS

STANDARD SIZE BY IMPLEMENT.....	3-26	ENGINE COOLANT TEMPERATURE GAUGE.....	4-19
<b>DeSCRIPTION OF OPeRATING SYSTem .....</b>	<b>4-1</b>	TURN SIGNAL LAMP.....	4-20
<b>eXTeRIOR vleW (CABIN) .....</b>	<b>4-3</b>	BATTERY CHARGING LAMP .....	4-20
<b>eXTe RIOR vleW (ROPS) .....</b>	<b>4-4</b>	HEAD LIGHT HIGH BEAM LAMP .....	4-20
<b>SWITCh mOUNTING LOCATIOn .....</b>	<b>4-5</b>	GLOW PLUG INDICATOR .....	4-21
KEY SWITCH .....	4-7	ENGINE OIL PRESSURE WARNING LAMP .....	4-21
COMBINATION SWITCH .....	4-8	DIFFERENTIAL LOCK WARNING LAMP .....	4-22
HAZARD LAMP SWITCH.....	4-9	AIR FILTER WARNING LAMP.....	4-22
4WD SWITCH.....	4-10	QUICK / TURN WARNING LAMP (IF EQUIPPED).....	4-22
PTO SWITCH .....	4-12	4WD INDICATOR .....	4-23
PTO SELECTION SWITCH.....	4-13	FORWARD INDICATOR .....	4-23
REGENERATION UNDERWAY BUTTON .....	4-13	NEUTRAL INDICATOR .....	4-23
CLUTCH PEDAL ENGAGEMENT CONTROL BUTTON.....	4-14	REVERSE INDICATOR .....	4-24
PTO CRUISE.....	4-15	PTO INDICATOR.....	4-24
CALIBRATION SWITCH.....	4-16	PARKING BRAKE WARNING LAMP.....	4-24
<b>INSTRUmENT PANeL .....</b>	<b>4-17</b>	LOW FUEL LEVEL WARNING INDICATOR .....	4-25
TACHOMETER/HOURMETER .....	4-18	COOLANT TEMPERATURE WARNING LAMP.....	4-25
FUEL GAUGE.....	4-18	WATER IN FUEL WARNING LAMP .....	4-25
		REGENERATION WARNING LAMP .....	4-26
		REGENERATION UNDERWAY LAMP.....	4-26
		ENGINE CHECK WARNING LAMP .....	4-26



# TABLE OF CONTENTS

CRUISE PTO WARNING LAMP .....	4-27	<b>CABIN SYSTEM .....</b>	<b>4-45</b>
BRAKE (ONE SIDE) LAMP .....	4-27	INTERIOR DEVICES.....	4-45
<b>OPERATING The CONTROLS .....</b>	<b>4-28</b>	EXTERIOR DEVICES.....	4-47
MAIN SHIFT LEVER.....	4-31	ENTRANCE.....	4-47
RANGE GEAR SHIFT LEVER.....	4-31	REAR WINDOW.....	4-48
SHUTTLE SHIFT LEVER .....	4-32	SIDE WINDOW.....	4-48
PTO SHIFT LEVER .....	4-33	WORKING LIGHT.....	4-49
CLUTCH PEDAL .....	4-34	WIPER .....	4-49
BRAKE PEDAL.....	4-35	RADIO CASSETTE/CD PLAYER	
STEERING WHEEL ADJUSTMENT.....	4-35	(IF EQUIPPED).....	4-50
PARKING BRAKE LEVER .....	4-36	ANTENNA.....	4-51
FOOT THROTTLE .....	4-37	CABIN LAMP .....	4-51
HAND THROTTLE LEVER.....	4-37	ACCESSORY .....	4-52
DIFFERENTIAL LOCK PEDAL.....	4-38	SUN VISOR (IF EQUIPPED).....	4-53
SEAT ADJUSTMENT.....	4-38	RECIRCULATION/FRESH AIR MODE.....	4-53
POSITION CONTROL LEVER .....	4-41	HEATER AND AIR CONDITIONER .....	4-54
DRAFT CONTROL LEVER.....	4-42	7-PIN POWER OUTPUT SOCKET .....	4-57
JOYSTICK LEVER .....	4-42	TIRES, WHEELS AND BALLAST .....	4-58
LIFTING ARM (LOWER LINK) SPEED		INFLATION PRESSURE .....	4-59
CONTROL KNOB.....	4-43	TREAD.....	4-60
DOUBLE ACTING LEVER.....	4-43	WHEEL TORQUE AND DIRECTION.....	4-64



# TABLE OF CONTENTS

ADDITIONAL WEIGHT .....	4-65	PRECAUTIONS WHEN USING POWER STEERING ..	5-19
MASS(ES) AND TIRE(S) .....	4-68	3-POINT HITCH CONTROL SYSTEM .....	5-21
<b>OPeRATION .....</b>	<b>5-1</b>	REMOTE HYDRAULICS .....	5-24
<b>PRe-OPeRATION CheCK .....</b>	<b>5-2</b>	CONNECTING AND DISCONNECTING IMPLEMENT....	5-27
<b>OPeRATING The eNGINE .....</b>	<b>5-3</b>	<b>3-POINT hITCh ImPLemeNT AND LOADeR</b>	
STARTING THE ENGINE .....	5-3	<b>OPeRATION .....</b>	<b>6-1</b>
CHECKING WARNING LAMPS .....	5-7	<b>RemOVAL AND INSTALLATION OF 3-POINT</b>	
STOPPING THE ENGINE .....	5-7	<b>hITCh ImPLemeNT (WITH PTO ShAFT).....</b>	<b>6-2</b>
WARMING UP .....	5-8	<b>OPeRATION TIP FOR 3-POINT hITCh e LemeNTS ....</b>	<b>6-5</b>
JUMP STARTING .....	5-10	ADJUSTMENT OF LIFT ROD .....	6-5
<b>OPeRATING The TRACTOR .....</b>	<b>5-11</b>	ADJUSTMENT OF TOP LINK .....	6-6
HOW TO DRIVE .....	5-11	PRECAUTION FOR INSTALLING / HOW TO USE	
PARKING .....	5-14	TOP LINK HOLES .....	6-6
TURNING .....	5-16	ADJUSTMENT OF STABILIZER .....	6-7
DRIVING ON SLOPES .....	5-16	DISMOUNTING THE IMPLEMENT .....	6-7
PRECAUTIONS WHEN COMING IN AND		DRAW BAR AND TRAILER .....	6-7
OUT OF WORK FIELD.....	5-17	INSTALLING PTO SHAFT .....	6-9
PRECAUTIONS WHILE DRIVING ON THE ROAD .....	5-17	<b>hANDLING LOADeR .....</b>	<b>6-11</b>
LOADING AND UNLOADING.....	5-18	FIXATION POINTS FOR FRONT END LOADER .....	6-12



# TABLE OF CONTENTS

DRIVING ON SLOPES .....	6-13	EASY CHECKER (I) .....	7-13
JOYSTICK LEVER .....	6-14	CHECKING HEAD LIGHT, HAZARD LIGHT ETC. (J).....	7-13
JOYSTICK VALVE PORT .....	6-17	CHECKING SEAT BELT AND CABIN (K).....	7-13
<b>mAINTeNANCe .....</b>	<b>7-1</b>	CHANGING ENGINE OIL AND REPLACING FILTER (L) .....	7-13
<b>mAINTeNANCe CheCK LIST .....</b>	<b>7-3</b>	REPLACING TRANSMISSION FLUID AND FILTER (M) .....	7-15
DAILY CHECK CHART.....	7-3	INSPECTION FRONT AXLE CASE OIL (N1) .....	7-17
MAINTENANCE SCHEDULE CHART.....	7-4	CHANGING FRONT AXLE CASE OIL (N).....	7-17
<b>LUBRICANTS .....</b>	<b>7-7</b>	ADJUSTING BRAKE PEDAL (O) .....	7-18
<b>mAINTeNANCe CODE .....</b>	<b>7-8</b>	LUBRICATING GREASE LOCATIONS (P).....	7-19
HOW TO OPEN THE HOOD (A) .....	7-8	CHECKING WHEEL BOLT/NUT TORQUE (Q).....	7-20
CHECKING AND ADDING FUEL (C) .....	7-8	ADJUSTING CLUTCH PEDAL (R).....	7-20
CHECKING TRANSMISSION FLUID LEVEL (D) .....	7-9	REPLACING FUEL FILTER (S).....	7-21
CHECKING ENGINE OIL LEVEL (E) .....	7-10	REPLACING AIR CLEANER PRIMARY ELEMENT (T).....	7-21
CHECKING COOLANT LEVEL (F).....	7-11	REMOVING WATER FROM FUEL FILTER (T1).....	7-22
CLEANING GRILL, RADIATOR SCREEN (G).....	7-12	BLEEDING FUEL LINES (T2) .....	7-23
CHECKING BRAKE AND CLUTCH PEDALS (H).....	7-12	CHECKING FUEL LINES (U) .....	7-24
CHECKING GAUGES, METER AND			





# TABLE OF CONTENTS

ADJUSTING FAN BELT TENSION (V).....	7-25	REPLACING FUSE (AN).....	7-38
BATTERY (W).....	7-26	REPLACING CABIN FUSE (AO).....	7-39
CHECKING INTAKE AIR LINE (X).....	7-28	SLOW BLOW FUSE (AP).....	7-41
ADJUSTING TOE-IN (Y).....	7-28	MAIN FUSE (AS).....	7-41
CHECKING RADIATOR HOSE AND CLAMP (Z).....	7-29	REPLACING BULB (AQ).....	7-42
POWER STEERING LINE (AA).....	7-30	CHECKING REFRIGERANT (AR).....	7-47
AIR CONDITIONER BELT TENSION (AB).....	7-30	AIR CONDITIONER MAINTENANCE (AS).....	7-47
CLEANING AIR CONDITIONER CONDENSER (AC).....	7-31	TURBOCHARGER (AU).....	7-48
ADJUSTING FRONT AXLE PIVOT (AD).....	7-31	<b>STORAGE AND DISPOSAL.....</b>	<b>8-1</b>
ADJUSTING ENGINE VALVE CLEARANCE (AE).....	7-31	<b>TRACTOR STORAGE.....</b>	<b>8-2</b>
REPLACING AIR CLEANER FILTER (AF).....	7-32	DAILY STORAGE.....	8-2
CHECKING AIR CONDITIONER HOSE (AG).....	7-32	LONG-TERM STORAGE.....	8-2
CHECKING CAB CUSHION RUBBER (AH).....	7-32	USING TRACTOR AFTER STORAGE.....	8-4
REPLACING AIR FILTER (AI).....	7-33	<b>USAGe AND DISPOSAL.....</b>	<b>8-5</b>
FLUSH COOLING SYSTEM AND CHANGING COOLANT (AJ).....	7-33	<b>TROUBLEShOOTING.....</b>	<b>9-1</b>
ANTI-FREEZE.....	7-34	<b>eNGINe TROUBLEShOOTING.....</b>	<b>9-2</b>
DRAINING WATER FROM CLUTCH HOUSING (AL).....	7-35	<b>TRACTOR TROUBLEShOOTING.....</b>	<b>9-4</b>
CHECKING AND REPLACING WIPER (AP).....	7-36	<b>INDeX.....</b>	<b>10-1</b>



## SAFeTY AND vehICLe DAmAGe WAReNING

This manual includes information titled as **WARNING**, **CAUTION**, **ImPORTANT** and **NOTe**. These titles indicate the following:



This indicates that a condition may result in harm, serious injury or death to you or other persons if the warning is not heeded. Follow the advice provided with the warning.



This indicates that a condition may result in damage to your vehicle or its equipment if the caution is not heeded. Follow the advice provided with the caution.



This mark indicates emphasis on notable characteristics of working procedures, and information about technology for easier operation.



















This indicates that interesting or helpful information is being provided.



## UNIveRSAL SYmBOLS

Various universal symbols have been used on the instruments and controls of your **KIOTI** tractor. Below is a list of the universal symbols and their meanings.

 Fuel-level	 Headlight-low beam	 Preheat
 Parking brake	 Headlight-high beam	AUTO Auto switch
 Battery charging condition	 Four-wheel drive-on	<b>F</b> Forward
 Engine oil-pressure	 Fast	<b>N</b> Neutral
 Power take-off clutch control-off position	 Slow	<b>R</b> Reverse
 Power take-off clutch control-on position	 Differential lock	 Loader joystick handle
 Turn signal	 Hazard warning lights	





# SAFeTY PReCAUTIONS

## **PReCAUTIONS BeFORe OPeRATION ..... 1-2**

GENERAL PRECAUTIONS.....1-2

## **PReCAUTIONS DURING OPeRATION ..... 1-5**

WHEN STARTING THE ENGINE .....1-5

WHEN DRIVING THE TRACTOR .....1-9

WHEN PARKING THE TRACTOR ..... 1-11

WHEN OPERATING THE PTO ..... 1-11

WHEN USING THE 3-POINT HITCH .....1-12

## **SAFeTY PReCAUTIONS DURING SeRvICING ..... 1-12**

## **SAFeTY PReCAUTIONS WhEN USING The LOADeR 1-17**

## **SAFeTY DeCAL mAINTeNANCe ..... 1-20**

DECAL MOUNTING LOCATION .....1-20

## **SAFeTY DeCAL mAINTeNANCe ..... 1-20**

DECAL MOUNTING LOCATION .....1-20

DECALS .....1-22

CAUTIONS FOR DECAL MAINTENANCE .....1-25

1 1



## PReCAUTIONS BeFORe OPeRATION

### GeNeRAL PReCAUTIONS

A careful operator is the best operator. Most accidents can be avoided by observing certain precautions. To help prevent accidents, use these safety precautions, and pay attention to the job at hand. If you can prevent an accident, your time will have been well spent.



1. It is recommended that you read and understand this entire manual before operation of your new tractor. Failure to do so could result in accidents, injury, or death!
2. Only persons who are properly trained should be allowed to operate the tractor.
3. Read and follow all warning labels and decals affixed to the tractor.
4. Replace any missing or damaged decals as soon as it is practical. A list of decals is shown on page 1-19~24.
5. Keep safety decals clean of dirt and debris.
6. Watch where you are going at all times so that you are able to avoid obstacles that can cause injury or damage to your tractor.
7. When starting the tractor make sure your path is clear of people to avoid accidents caused by sudden movements.
8. Before operating in reverse movements with your tractor, you should always check to see that the path is clear.

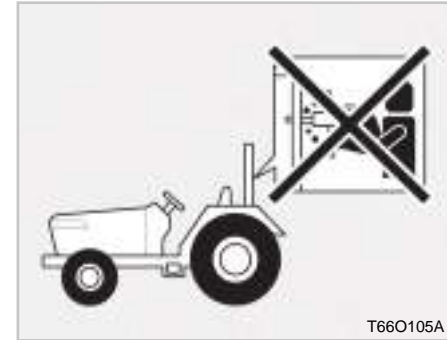
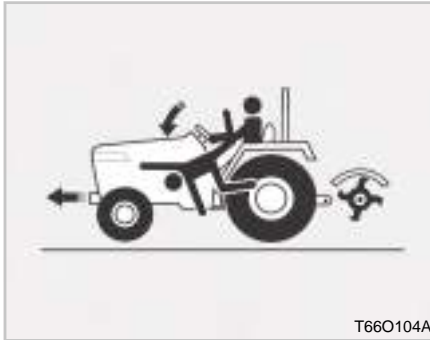
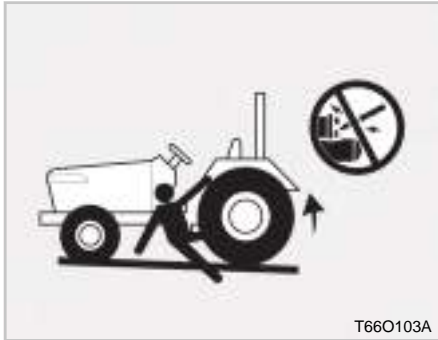

1

9. Never operate this tractor or any other agricultural equipment while under the influence of alcohol, drugs or while fatigued.
10. While working in cooperation with other tractors always communicate your intentions.
11. Do not start your tractor by shorting across the starter.

12. Never start the engine while standing on the ground.
13. Only the operator should ride on the tractor unless a passenger seat is installed. Keep bystanders away from the tractor while in operation.
14. When getting on or off the tractor, make sure to hold the hand rail and set your feet on the step firmly to ensure your safety. This will help to prevent accidental slips trips and falls.
15. Be sure to scrape off mud or soil from your shoes before mounting the tractor.

16. All persons using the tractor should have knowledge of its proper operation and should read this manual carefully.
17. Never get off the tractor without setting the parking brake, lowering the implement to the ground and shutting of the tractor.
18. No modifications should be made to your **KIOTI** tractor.



19. Before starting your tractor you should depress the clutch and make sure that all shift levers are in the neutral position and parking brake is applied.

20. For your safety, a **ROPS** with a seat belt is recommended for all applications.

 **NOTE**

- Always use seat belt when the tractor is equipped with a **ROPS** and **CAB**. **Never Use The SeAT BeLT When TRACTOR IS NOT eQUIPPeD WITH A ROPS.**

(**ROPS**: Roll-Over Protective Structures)

A **ROPS** and **CAB** should never be modified by welding, grinding or cutting, as this can weaken the **ROPS** structure. If any components of the **ROPS** unit is damaged, it must be replaced.

If the **ROPS** unit is removed or loosened for any reason, the parts should be fitted back to their original positions and all bolts should be properly torqued.

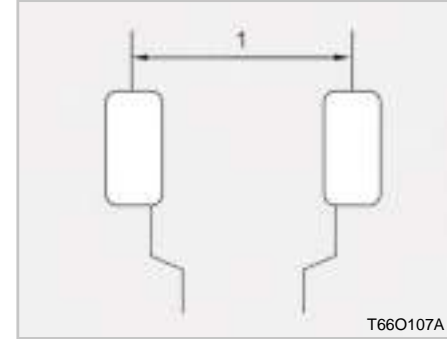

(1) Tread

21. Extra caution should be taken when driving tractors with narrow tread widths. For added stability you should adjust your rear wheel tread width, see page 4-48.







## PRECAUTIONS DURING OPERATION

### When STARTING The eNGINE

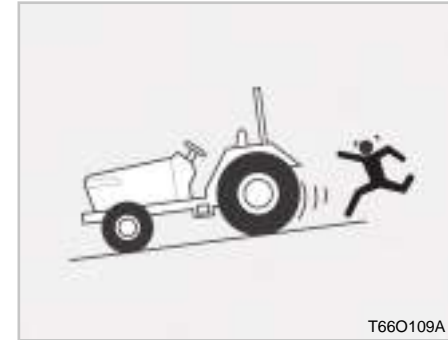
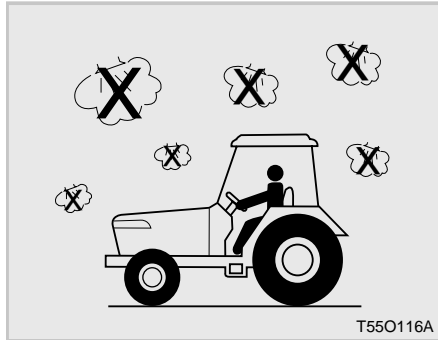

1

22. This cabin is not certified as chemical proof, never operate the tractor for chemical spraying or in the air contaminated by any chemical or equivalent without approved personal safety equip; cartridge respiration/chemsvit/ eyeprotection/gloves/etc.

1. Avoid accidental contact with gear shift levers while the engine is running. Unexpected tractor movements can result in bodily injury or death.

2. Do not park your tractor on a steep incline, and remember to shut off the engine and PTO before dismounting the tractor.

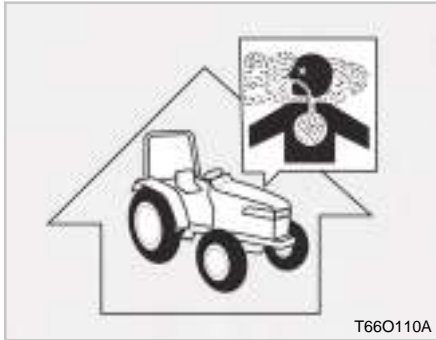

(1) Drawbar

(2) Front Hitch Receiver

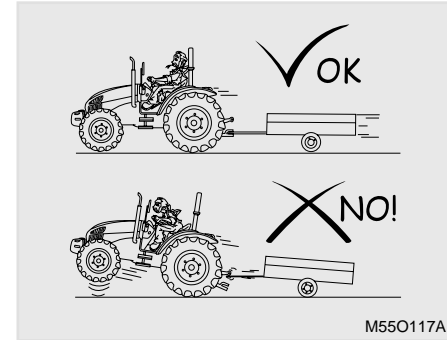

3. Do not operate your tractor in an enclosed building without the proper ventilation. Exhaust containing carbon monoxide can cause serious injury or death.

4. Make sure that all pressure lines are tight before starting the tractor.

5. The front hitch receiver can be installed on front axle frame. Pull only from the draw-bar and front hitch receiver. **Never hitch ANYTHING TO The AXLe HOUSING OR ANY OTHER POINT eXCePT INDICATeD POINTS.** Pulling from any other location only increases the risk of serious personal injury or death.

6. Improper use of the draw-bar, even if correctly positioned, can cause a rear overturn.

7. Do not overload an attachment or towed equipment. Use proper counterweights to maintain tractor stability. Hitch heavy loads to the draw-bar only.

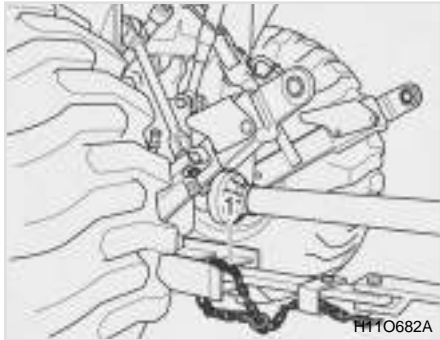

8. Check for correct coupling between tow hook and trailer. See the Towing Attachments chapter.
9. Use ballast weight as recommended. Never add more ballast to compensate a higher load than allowed. Reduce load for safety.
10. A safety chain will help control drawn equipment should it be accidentally separated from the draw-bar while transporting. Us-

ing the proper adaptor parts, attach the chain to the tractor draw-bar support or other specified anchor locations. Provide only enough slack in the chain to permit turning. See your Dealer for a chain with a strength rating equal to, or greater than the gross weight of the towed equipment.



11. If the front of the tractor tends to rise up when heavy implements are attached to the three point hitch, weights should be installed on front of the tractor. Do not operate the tractor with a light front end.



12. Always use the proper ballast weight on your tractor when using rear implements.
13. Watch front and rear to avoid obstacles at row ends, near trees and around other obstructions.

**⚠ WARNING**

- *Drive carefully to avoid injury from penetration of objects from sides, because this machine does not comply to OPS.*

14. Do not leave implement and attachments in the raised position when the vehicle is stopped or unattended.
15. When using implements or attachments with your tractor you should first read their respective owner's manual. You should always keep their safe operation procedures in mind.

**16. YOU SHOULD Be FAMILIAR WITH YOUR eQUIPmeNT AND ITS LIMITATIONS.**

17. If abused or used incorrectly your tractor can become dangerous to you and bystanders. Overloading your tractor or using unsafe equipment can also be dangerous and should be avoided. Refer to the "Specifications of Implement Limitation", which outlines the maximum load for safe tractor operation.

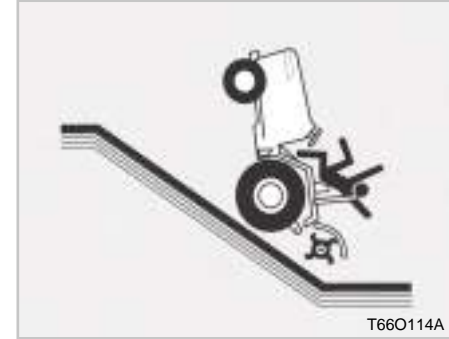

18. Driving forward out of a ditch or up steep inclines can cause the tractor to tip over backwards. To avoid this you should back out of these positions. Four wheel drive tractors can give you a false sense of security in the tractors ability to maneuver out of these positions, so extra caution should be taken.
19. Never try to get on or off a moving tractor.





## When DRIVING The TRACTOR

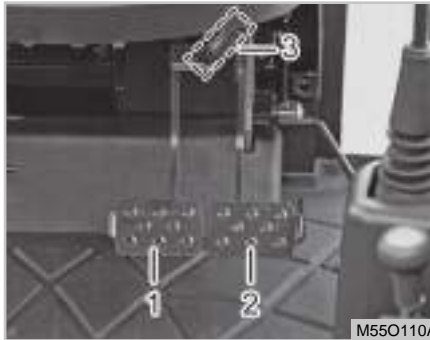
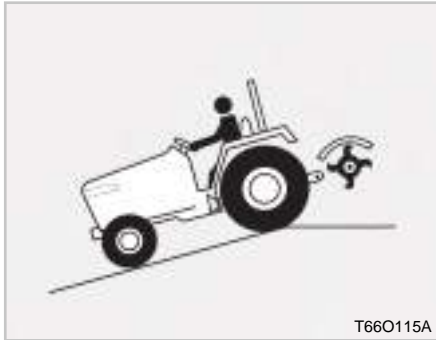

(1) Brake Pedal (L)      (2) Brake Pedal (R)  
(3) Brake Pedal Lock



1

20. When working in groups, always let the others know what you are going to do before you do it.
21. Never "freewheel" by disengaging the clutch or shifting into neutral while descending a slope, as this could lead to a loss of control.
22. Do not operate near ditches, holes, embankments, or other terrain features which may collapse under the tractor's weight. The risk of tractor upset is even higher when the ground is loose or wet.

1. Lock the brake pedals together when traveling at road speeds. Brake both wheels together. when making an emergency stop. Uneven braking at road speeds could cause the tractor to tip over.

2. Always slow the tractor before turning. Turning at high speed may tip the tractor over or cause a loss of control.



(1) SMV Emblem

3. Make sure that the Slow Moving Vehicle (SMV) sign is clean and visible. Use hazard lights as required.

4. Observe all local traffic and safety regulations.
5. Turn the headlights on. Dim them when meeting another vehicle.
6. Drive at speeds that allow you to maintain control at all times.
7. Do not apply the differential lock while traveling at road speeds. As the tractor may run out of control.
8. Avoid sudden movements of the steering wheel as this can cause a loss of control of the tractor. This risk is especially great when traveling at road speeds.
9. Do not operate an implement while the tractor is on the road. Lock the three point hitch in the raised position.
10. When towing other equipment, use a safety chain and place an SMV emblem on it as well.



(1) Low Speed Indicator

11. When driving the tractor after sunset, be sure to turn on the low speed indicator. (If equipped)  
Otherwise, a collision can occur by poor visibility.

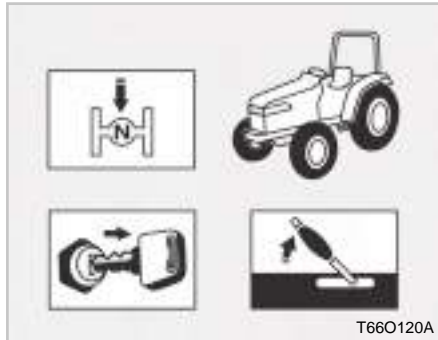

**When PARKING The TRACTOR**

1. Disengage the PTO, lower all implements, place all control levers in the neutral position, set the parking brake, stop the engine and remove the key.

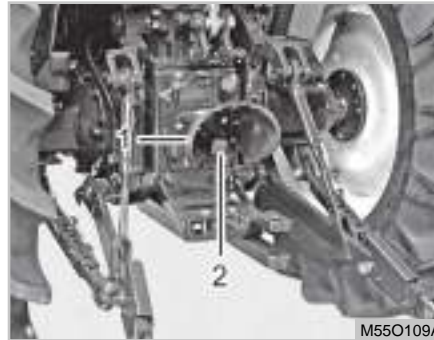
**When OPERATING The PTO**

(1) PTO Shaft Cover (2) PTO Shaft Cap

1. Make sure the tractor is completely stopped, gears are in neutral and all moving components have completely stopped before connecting, disconnecting, adjusting, cleaning or servicing any PTO driven equipment.
2. Keep the PTO shaft cover in place at all times. Replace the PTO shaft cap when the shaft is not in use.
3. Before installing or using PTO driven equipment, read the man-

ufacturer's manual and review the safety labels attached to the equipment.

1

**⚠ WARNING**

- Before driving an implement with the PTO, always make sure that all bystanders are well away from the tractor.
- When using the PTO drive with a stationary tractor, always make sure that the gears are in neutral and that the parking brake is applied.
- Before starting up any PTO-driven implement hitched to the three-point linkage, lift the implement to its full height and check that at least 1/4 of the total length of the telescopic section of the drive shaft is engaged.
- ensure that implements and attachments are properly installed and that the tractor and implement PTO RPM ratings match.



### When USING The 3- POINT hITCh



(1) 3-point hitch lowering speed knob  
(A) "SLOW" (B) "FAST"

4. When operating stationary PTO driven equipment, always apply the tractor parking brake and place chocks behind and in front of the rear wheels. Stay clear of all rotating parts.
5. Do not attach a PTO driven implement if the implements safety shields are damaged or not in place. Rotating shafts are an entanglement hazard.

1. Use the 3-point hitch only with equipment designed for 3-point hitch usage.
2. When using a 3-point hitch mounted implement, be sure to install the proper counterbalance weight on the front of the tractor.
3. When transporting on the road, set the implement lowering control in the "LOCK" position to hold the implement in the raised position.

### SAFeTY PReCAUTIONS DURING SeRvICING



In order to service your tractor you must park it on a flat level surface, set the parking brake, place the gear shift lever in neutral and stop the engine.

1. Do not smoke while working around the battery or when refueling your tractor. Keep all sparks and flames away from the battery and fuel tank. The battery presents an explosive hazard because it vents off hydrogen and oxygen gas, especially when recharging.

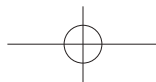





1

(1) Turbocharger

2. Allow the tractor time to cool off before servicing any part that may have become hot while the tractor was running.
3. You must always stop the engine before refueling the tractor. Avoid overfilling the tractor or spilling the fuel.
4. Before jump starting a dead battery, read and follow all of the instructions. (Refer to the page 5-8)
5. It is recommended to keep a first aid kit and fire extinguisher handy at all times.
6. Do not remove the radiator cap while the coolant is hot. When cool, slowly rotate the cap to the first stop and allow sufficient time for excess pressure to escape. After all the pressure is released remove the cap completely. If your tractor is equipped with a coolant recovery tank, add coolant there rather than to the radiator.

Never touch the turbocharger while the engine is running. Touching the turbocharger can cause serious injury.



 **NOTE**

- This engine is coated with anti-corrosive to prevent premature corrosion. This coating on hot components, including the exhaust manifold and turbocharger, may be deteriorated by high heat during use, resulting in loss of its effect. Therefore, such areas may be corroded in course of time.

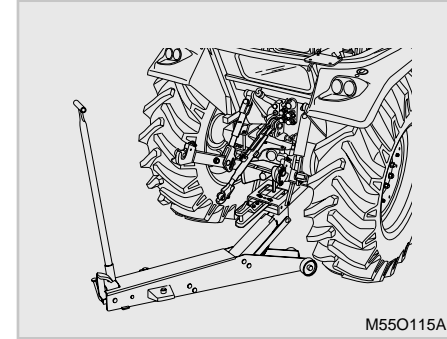
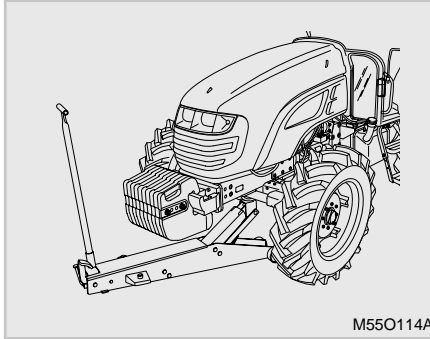

7. If the tractor must be lifted for servicing, take it to a suitably equipped workshop.
8. Carry out the following operations before any operation of the tractor: Engage the four-wheel drive, the first gear and the parking brake and put chocks to the wheels touching the ground.
9. Before lifting the tractor, prevent it from swinging by means of wooden wedges applied to the front axle.
10. Use a floor jack of suitable capacity and apply them at the centre of the front and rear axles while paying due attention to weight distribution.
11. No decals for the lifting point are applied on the tractor, as they would be, too difficult to apply in the available spaces and would be all too easily removed or effaced during normal operation of the tractor.



 **NOTe**

- Apply the jack lift to the lifting points according to the type of operation and follow the safety procedures given before.



1

12. When working with your tractors electrical components you must first disconnect the battery cables.
13. **TO eNSURe ThAT ThERe ARE NO ACCIDeNTS FROM SPARKS YOU mUST FIRST DISCONNeCT The NeGATive BATTeRY CABLE.**

14. Tire mounting should be done by qualified professionals, with the proper equipment.
15. Maintaining correct tire pressure is important for the life of your tires. Do not inflate the tires above the recommended pressure specified in the owner's manual. (See page 4-46)
16. Securely support the tractor when changing wheels or the wheel tread width.

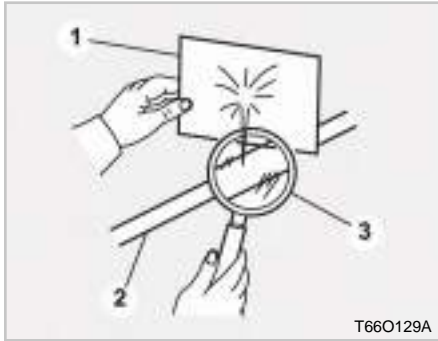

(1) Cardboard (2) Hydraulic Line  
(3) Magnifying Glass



T66O130A



T66O131A

17. Make sure that wheel bolts have been tightened to the specified torque.
18. Leaking hydraulic fluid under pressure has sufficient force to penetrate skin, causing serious personal injury. Be sure to release all residual pressure. Before disconnecting hydraulic lines. Before adding pressure to the hydraulic system, make sure that all connections are tight and that all lines, pipes and hoses are free of damage.

**19. FLUID eSCAPING FROM PIN-hOLEs MAY Be INvISIBLE. DO NOT Use hANDS TO SeARCH FOR SUSPeCTeD LeAKS;**

Use a piece of cardboard or wood, instead. Use of safety goggles or other eye protection is also highly recommended. If injured by leaking fluid, see a medical doctor at once. This fluid can produce gangrene and/or severe allergic reaction.

20. Keep environmental pollution in mind. When replacing coolant or oil, dispose of it properly. Be sure to observe all relevant regulations when you dispose of the engine oil, transmission oil, fuel, coolant, filters and battery.

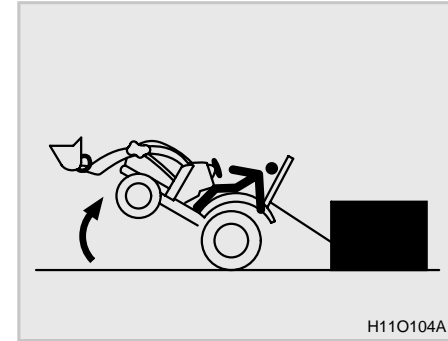
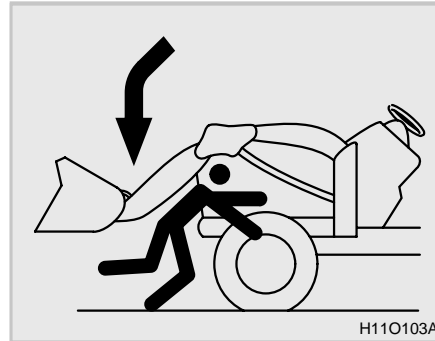
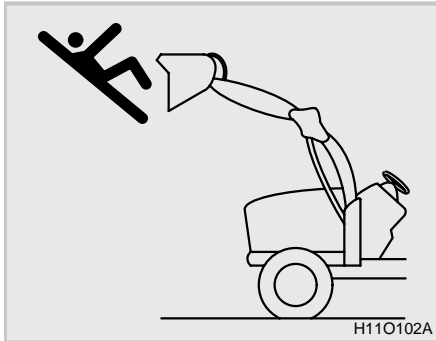
**SAFETY PRECAUTIONS When USING The LOADER**

1

1. Never let anyone get in the loader and use the loader as a workstation. Otherwise, it may lead to a fatal injury or even death.

2. Do not stand under the lifted loader or get close to it. Also, lower the loader arm onto the ground before leaving the tractor. Otherwise, it may lead to a fatal injury or even death. Use the safety bar to prop up the loader.

3. The loader can be turned over if a draw-bar is improperly loaded. Make sure to use a draw-bar proper for the 3-point hitch lower link. Otherwise, it may lead to an injury or even death.

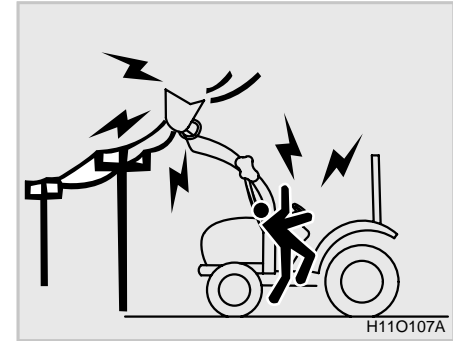
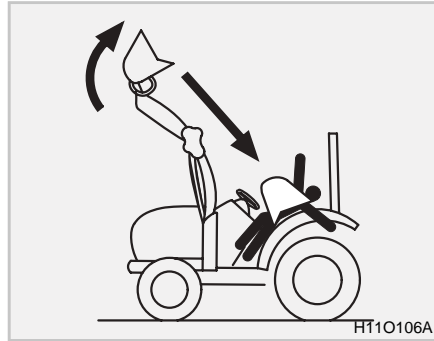
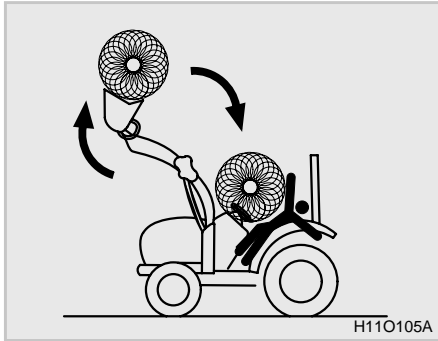

4. Never carry a big object with the loader unless the correct implement is attached. Keep a carried object low during driving. Otherwise, it may lead to an injury or even death.

5. When attaching or detaching the loader, fit all parts which are connected to the bucket and boom. The bucket or boom can be accidentally dropped down, leading to an injury or even death.

6. Do not allow loader arms or attachment to contact electrical power lines. Electrocution will cause serious injury or death.





1

7. Keep bystanders away. No riders.  
Otherwise, it may lead to a fatal  
injury or even death.



1-20 RX6020 / RX6620 / RX7320 / RX7620

## SAFeTY DeCAL mAINTeNANCe DeCAL mOUNTING LOCATIOn (CABIN)



T11O105A







1

T11O106A





## DeCAL mOUNTING LOCATION (ROPS)



T110107B





1



T11O108B

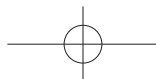

# DeCALS

1. Part No. : T4710-52201

**⚠ WARNING**

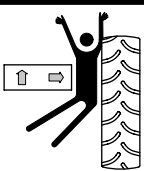

Lifting

↑  
↓

Lowering

**ⓘ Precautions during rocker switch operation**

- ▶ Do not operate any part outside the vehicle other than installation and removal of an implement.
- ▶ Make sure to set all the levers in their neutral position and apply the parking brake before working on level ground.
- ▶ Turn OFF the P.T.O switch before working the tractor.
- ▶ Working the tractor with the engine at a high speed can cause the attached implement moving up, down, left or right abruptly. Make sure to run the engine at a low speed and secure a safe distance before working on a field.

T4710-52201

2. Part No. : T4810-52121

**⚠ PreCAUTIONS DURING OPERaTION**

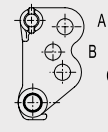

1. The auxiliary equipment doesn't need to draft (rotary etc).  
 Position of the top link :  DRIVING A  
WORKING A

2. The auxiliary equipment needs to draft (plow etc).  
 Position of the top link :  DRIVING A  
WORKING B,C

\* Be sure to fix on "A" position of the top link, while driving with the auxiliary equipment on common and farm load.  
 \* Must keep because of draft control sense of trouble while drive to be stuck the top link to working position of draft control equipment (B, C).

T4810-52121

4. Part No. : T4601-52411

**⚠ CAUTION**

1. Replace cartridge after every 250 hours of use.
2. Apply a thin film of oil to the surface of gasket before screwing on.
3. Tighten filter by hand.
4. When filter has been removed, the oil level will decrease. Be sure to check the crankcase oil level and refill to designated level. After starting the engine, check for leaks.

T4601-52411

3. Part No. : T4930-52391

**⚠ CAUTION**

1. To use an implement that uses external hydraulic pressure, such as a front loader, check the transmission fluid amount. If it is insufficient, add the fluid before its operation.
2. Lower the bucket onto the ground before stopping the engine. Otherwise, it can cause an accident or injury.



G

H



F



E

T4930-52391

5. Part No. : T4950-52451

**⚠ CAUTION**

1. This vehicle is equipped with the turbocharged engine. Avoid rapid turn, acceleration or start-off right after the engine is started. Also, idle the engine for approx. 1 minute before operation.
2. Also, idle the engine for approx. 1 minute before stopping the engine.



T4950-52451



6. Part No. : T4601-52191

<b>CAUTION</b>	
<p>Unlock</p>  <p>Lock</p>	<p>1. Using parking brake</p> <ul style="list-style-type: none"> <li>* Engage the parking brake before parking and leaving the vehicle.</li> <li>* Depress the brake pedal when releasing it.</li> </ul> <p>2. Shifting</p> <ul style="list-style-type: none"> <li>* When shifting, depress the clutch pedal firmly. Otherwise, abnormal noise is produced and the gear can be damaged.</li> </ul>
<small>T4601-52191</small>	

8. Part No. : T4930-52471

<b>WARNING</b>	
 	<ul style="list-style-type: none"> <li>■ Do NOT run an engine in an enclosed area.</li> <li>■ Exhaust fumes cause sickness or possible death.</li> <li>■ Do NOT touch a muffler with bare hands.</li> </ul>
<small>T4930-52471</small>	

10. Part No. : T4625-52351



 
<small>T4625-52351</small>

1

7. Part No. : T4930-52371

<b>WARNING</b>	
	
<p>Do not remove the radiator cap when the engine is running or while the engine is hot. If the radiator cap is removed, hot vapor or liquid may be violently released causing burns.</p>	
<small>T4930-52371</small>	

9. Part No. : T4930-52311

<b>WARNING</b>	
	<p><b>To prevent severe and deadly injuries during P.T.O. operation:</b></p> <ol style="list-style-type: none"> <li>1. All protective components should be in place.</li> <li>2. Do not let your hands, feet and clothes come near the implement.</li> <li>3. When disengaging an implement from the P.T.O., stop the engine in advance. When repairing or servicing the tractor or its part, depress the brake pedal to set the parking brake. Also, make sure to chock the wheels when parking on a hill.</li> </ol>
<p><b>To prevent accident during operation:</b></p> <ol style="list-style-type: none"> <li>1. Implement that pulls or pushes objects should be attached only to the drawbar.</li> <li>2. Implements that are designed to use the 3-point hitch should only use the 3-point hitch.</li> </ol>	<small>T4930-52311</small>



11. Part No. : T4682-53552



12. Part No. : T4930-52481

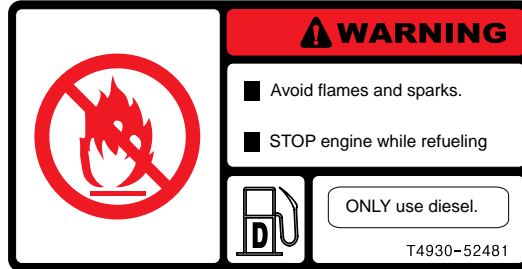

13. Part No. : T5210-52311

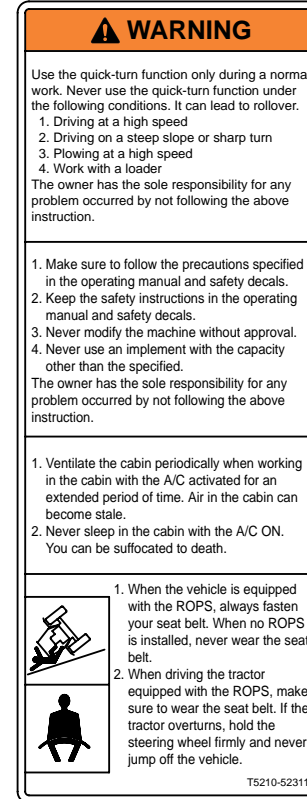



## CAUTIONS FOR DeCAL mAINTeNANCe

Safety decals are attached to the tractor for safe operation. Make sure to follow the instruction on the decals as well as the following instruction:

### CAUTION

- **Keep the decals clean and intact. If any decal is dirty, wash it with soap and dry with a soft cloth.**
- **Never use a solvent, such as thinner or acetone, since it can ruin the decals.**
- **Do not spray high-pressure water directly onto the decal. The decal may fall off the tractor.**

### ImPORTANT

- **If a decal is damaged or lost, contact your local KIOTI dealer immediately to install a new decal.**
- **make sure to attach the decal in the correct position cleanly without bubbles after cleaning its mounting surface.**
- **If a decal is attached to a component to be replaced, replace the decal as well.**



memO







## *PReCAUTIONS BeFORe OPeRATION*

### **vehICLe IDeNTIFICATION NUmBeR ..... 2-2**

- TRACTOR SERIAL NUMBER .....2-2
- ENGINE SERIAL NUMBER.....2-2
- TRANSMISSION SERIAL NUMBER .....2-2

### **eSSeNTIAL RePLACemeNT P ARTS ..... 2-4**

- OILS AND FLUIDS .....2-4
- FILTERS .....2-4
- BELTS AND RUBBER PARTS.....2-5
- OTHER COMPONENTS .....2-5

# 2

2



**vehICLe IDeNTIFICATION NUmBeR**  
**TRACTOR SeRIAL NUmBeR**



(1) Tractor Serial Number Plate

This number is to identify the vehicle, and its plate is attached on the front right side of the front axle frame.

**eNGINE SeRIAL NUmBeR**



(1) Engine Serial Number

The engine number is stamped on the cylinder block surface which is rear side of the alternator on the left side of the engine.

**TRANSMISSION SeRIAL NUmBeR**



(1) Transmission Serial Number

It is stamped on the range shift lever case on the left side of the tractor.

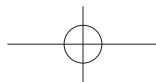



Your dealer is interested in your new tractor and has the desire to help you get the most value from it. After reading this manual thoroughly, you will find that you can do some of the regular maintenance yourself.

However, when in need of parts, warranty or major service, be sure to see your **KIOTI** dealer. For service, contact the **KIOTI** dealership from which you purchased your tractor or your local authorized **KIOTI** dealer.

When in need of parts, be prepared to give your dealer both the tractor and engine serial numbers.

Before using non-**KIOTI** approved implements, contact your nearest dealer, regarding safety application of the implement.

• **Tractor model Name:**

• **Tractor Serial No:**

• **engine Serial No:**

• **Date of Purchase:**

To be filled in by purchaser.

## eSSeNTIAL RePLACeMEnt P ARTS OILS AND FLUIDS

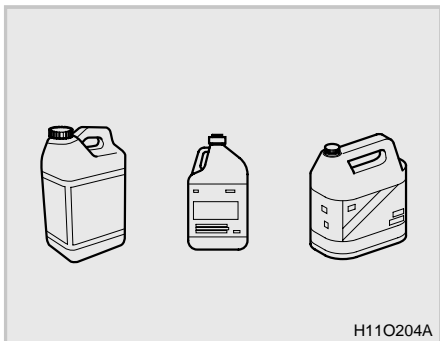

Various oils and fluids are used in this tractor for operation, lubrication, cooling, and anti-corrosion of various parts. If oil or fluid is insufficient, contaminated or degraded, it can cause poor performance, faulty operation, and seized parts on the tractor, leading to malfunctions.

Regularly add or change the fluid specified on the right to keep the tractor in perfect condition.

No.	ITem	SPeCIFICATION	CAPA	RemARK
			U.S.gal.(L)	
1	Engine oil	SAE 15W40 or SAE10W30	2.2 (8.3)	with filter 2.3 (9.0)
2	Transmission fluid	DAEDONG UTF55 Exxonmobil Mobilfluid424 BP: Tractran UTH Exxonmobil Hydraulic560 Shell: Donax TD	15.9 (60)	
3	Front axle case	SAE90 oil and the same level or above, or TM	2.2 (8.5)	
4	Grease	SAE multi purpose type grease	SAE 90 level more than or TM oil and the same	
5	Antifreeze	Fresh clean water with ethylene glycol (50:50)	-	

## FILTeRS

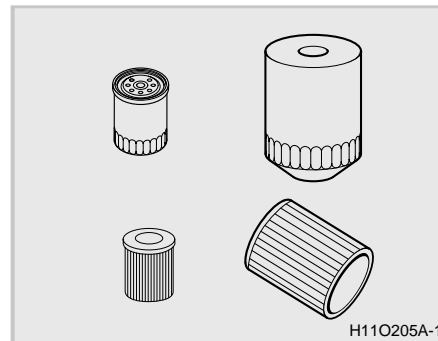

Filters for the engine, transmission, air cleaner, and A/C are consumables that purify oil and air. Make sure to replace these items when changing oil.

NO.	PART NO	DeSCRIPTION	QTY
1	E6201-32443	Engine Oil Filter	1
2	T4620-38032	Hydraulic Filter	1
3	T4682-25732	Fuel Filter Element	1
4	E7230-11081	Air Cleaner Filter	1



### BeLTS AND RUBBeR P ARTS

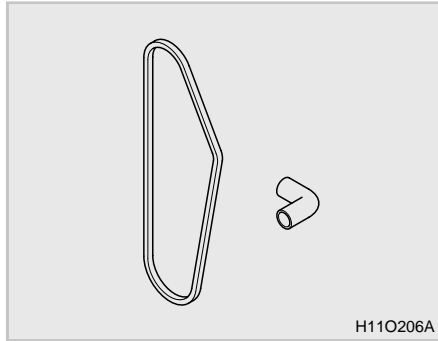

H11O206A

Belts, hoses and boots, which are made of rubber, get weakened and cracked as they age. If these parts remain in this state, they can be broken off, leading to a serious problem on the tractor. Therefore, regularly check or replace those items to prevent the failure.

NO.	PART NO	DeSCRIPTION	QTY
1	E6305-72533	Fan Belt	2
2	E7220-72611	A/C Belt	1

### OTHeR COMPONeNTS

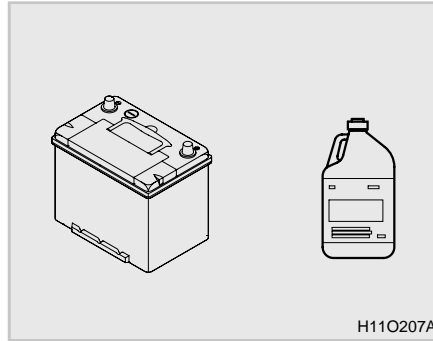

H11O207A

The battery condition is very important for engine start performance especially in winter.

Therefore, make sure to check its condition daily.

NO.	PART NO	DeSCRIPTION	QTY
1	C7910-42204	Battery	1



memO





# SPeCIFICATIONS

**GeNeRAL SPeCIFICATIONS ..... 3-2**

EXTERNAL DIMENSIONS .....3-2

GENERAL SPECIFICATIONS .....3-6

NOISE LEVELS AS PERCEIVED BY THE OPERATOR .....3-21

VIBRATION LEVELS OF THE  
TRACTOR EXPOSITION TO VIBRATIONS .....3-22

**TRAVeLING SPeeD ..... 3-23**

**ImPLemeNT LiMITATIONS..... 3-26**

STANDARD SIZE BY IMPLEMENT.....3-26

# 3

3



## GeNeRAL SPeCIFICATIONS eXTeRNAL DiMeNSIONS

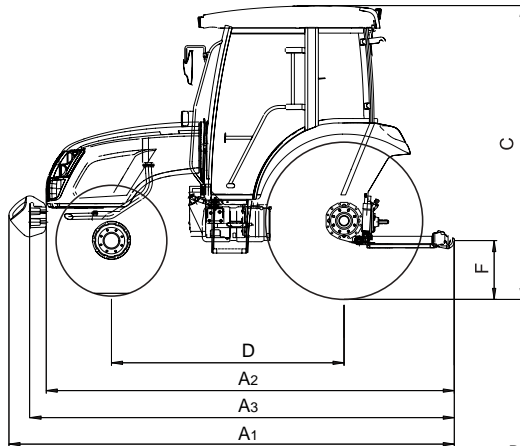
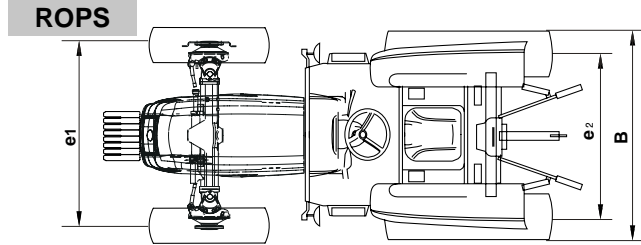
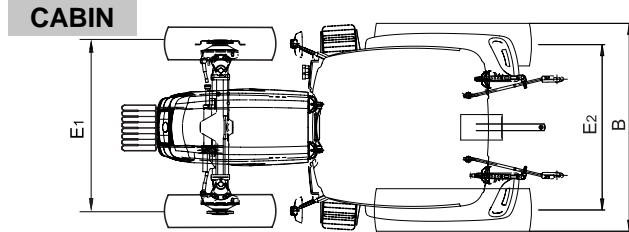

D470301A

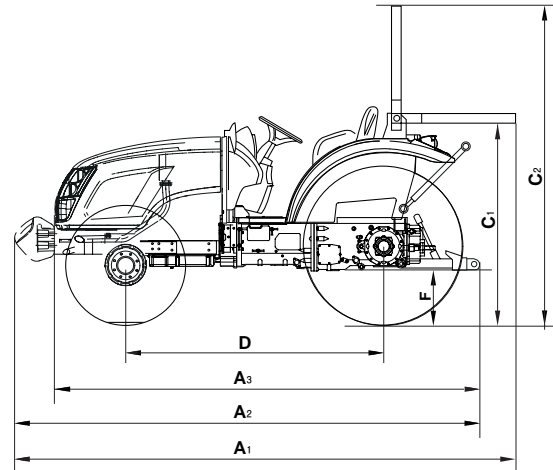

T110301A

※ These dimensions are measured with standard tires (AG) installed on the CABIN model tractor.





**[RX6020]**

in.(mm)

Item	RX6020				RemARK
	RX6020C	RX6020PC	RX6020	RX6020P	
1. Overall length (A1)	133.5 (3,390)	←	133.5 (3,390-US) 134.3 (3,410-EU/AU)	133.5 (3,390-US) 134.3 (3,410-EU/AU)	
2. Overall length (A2)	145.1 (3,685)	←	←	←	
3. Overall length (A3)	148.8 (3,780)	←	←	←	
4. Overall width (B)	69.1 (1,755)	←	←	←	US
	70.9 (1,800)	←	←	←	EU/AU
5. Overall height (C)	102.8 (2,610)	←	105.5(2,680)	←	US
	103.5 (2,630)	←	106.2(2,700)	←	EU/AU
6. Wheel base (D)	82.7 (2,100)	←	←	←	
7. Tread (E1)	53.5 (1,360)	←	←	←	US
	57.6 (1,465)	←	←	←	EU/AU
8. Tread (E2)	54.1 (1,375)	←	←	←	US
	55.7 (1,415)	←	←	←	EU/AU
9. Ground clearance (F)	15.7 (400)	←	←	←	US
	16.5 (420)	←	←	←	EU/AU

- ※ A1: Overall length including weights  
 A2: Overall length excluding weights  
 A3: Overall length including weight support  
 E1: Front wheel tread      E2: Rear wheel tread



**[RX6620 / RX7320]**

in.(mm)

Item	RX6620 / RX7320				RemARK
	RX6620C/PC	RX7320C/PC	RX6620/P	RX7320/P	
1. Overall length (A1)	134.2 (3,410)	137.0 (3,480)	134.2 (3,410)	137.0 (3,480)	
2. Overall length (A2)	145.0 (3,685)	146.2 (3,715)	145.0 (3,685)	146.2 (3,715)	
3. Overall length (A3)	148.8 (3,780)	150 (3,810)	148.8 (3,780)	150 (3,810)	
4. Overall width (B)	70.9 (1,800)	77.2 (1,960)	70.9 (1,800)	77.2 (1,960)	
5. Overall height (C)	103.5 (2,630)	104.5 (2,655)	105.5 (2,680-US)	107.4 (2,730)	
			106.2 (2,700-EU/AU)		
6. Wheel base (D)	82.7 (2,100)	83.9 (2,130)	82.7 (2,100)	83.9 (2,130)	
7. Tread (E1)	57.7 (1,465)	58.1 (1,475)	57.7 (1,465)	58.1 (1,475)	
8. Tread (E2)	55.5 (1,410)	59.6 (1,515)	55.7 (1,415)	59.6 (1,515)	
9. Ground clearance (F)	16.5 (420)	17.3 (440)	16.5 (420-US)	17.3 (440)	
			17.3 (440-EU/AU)		

- ※ A1: Overall length including weights
- A2: Overall length excluding weights
- A3: Overall length including weight support
- E1: Front wheel tread                      E2: Rear wheel tread

**[RX7620]**

in.(mm)

Item	RX7620				RemARK
	RX7620C	RX7620PC	RX7620	RX7620P	
1. Overall length (A1)	137.0 (3,480)	←	←	←	
2. Overall length (A2)	146.2 (3,715)	←	←	←	
3. Overall length (A3)	150 (3,810)	←	←	←	
4. Overall width (B)	77.2 (1,960)	←	←	←	
5. Overall height (C)	104.5 (2,655)	←	107.5 (2,730)	←	
6. Wheel base (D)	83.9 (2,130)	←	←	←	
7. Tread (E1)	58.1 (1,475)	←	←	←	
8. Tread (E2)	59.6 (1,515)	←	←	←	
9. Ground clearance (F)	17.3 (440)	←	←	←	

- ※ A1: Overall length including weights  
 A2: Overall length excluding weights  
 A3: Overall length including weight support  
 E1: Front wheel tread            E2: Rear wheel tread

### GeNeRAL SPeCIFICATIONS [RX6020]

Item		RX6020					
		RX6020C	RX6020PC	RX6020	RX6020P	RemARK	
Model		4F243T-TMC4	4F243T-TPC4	4F243T-TMC4	4F243T-TPR4	US/EU	
		4F243T-TMC3	4F243T-TPC3	4B243DTM-A	4B243DTP-A	AU	
Engine	Number of cylinders	4	←	←	←		
	Total displacement	cu in. (cc)	148.6 (2,435)	←	←	←	
	Bore and stroke	in. (mm)	3.4 x 4.0 (87 x 102.4)	←	←	←	
	Engine gross power	HP (kw)	60 (44.7)	←	←	←	
	P.T.O Power	HP (kw)	50.3 (37.5)	←	52.3 (39)	←	
	Rated revolution	rpm	2,600	←	←	←	
	Capacities	Fuel tank	U.S.gal (L)	25.1 (95)	←	22.5(85)	←
Transmission oil		U.S.gal (L)	15.9 (60)	←	←	←	
Front axle oil		U.S.gal (L)	2.2 (8.5)	←	←	←	
Drive train	Clutch		Single Dry Clutch	Hydro Multi Wet Disc Clutch	Single Dry Clutch	Hydro Multi Wet Disc Clutch	
	Transmission	Shuttle	Synchro Shuttle	Power Shuttle	Synchro Shuttle	Power Shuttle	
		Main	Synchro mesh 4 stages	←	←	←	
		Range	Constant mesh 3 stages	←	←	←	US
		Speeds	12 X 12	←	←	←	US



Item			RX6020				RemARK
			RX6020C	RX6020PC	RX6020	RX6020P	
Drive train	Transmission	Range	Constant mesh 2 X 3 stages	←	←	←	EU/AU
		Speeds	24 X 24	←	←	←	EU/AU
	Ground speed [Tire for agricultural (AG)]	Forward mph (km/h)	0.93~20.74 (1.51~33.38)	←	0.94~21.79 (1.51~35.07)	←	US
			0.10~20.98 (0.16~33.76)	←	0.10~22.59 (0.16~36.36)	←	EU/AU
		Reverse mph (km/h)	0.93~20.39 (1.49~32.82)	←	←	0.93~21.42 (1.49~34.48)	US
			0.10~20.63 (0.16~33.20)	←	0.10~22.21 (0.16~35.75)	←	EU/AU
	4-wheel drive		Hydro Multi Wet Disc Clutch	←	←	←	
	Quick Turn (QT)		NA	←	←	←	
	Brake		Wet Multi Disc	←	←	←	
	Differential lock		Rear Standard	←	←	←	
Tires	Agricultural	Front	9.5 - 20	←	←	←	US
			11.2 - 20	←	←	←	EU/AU
		Rear	14.9 - 28	←	←	←	US
			14.9 - 30	←	←	←	EU/AU
	Turf	Front	31 X 13.5 X 15/ 8	←	←	←	US
		Rear	44 X 18 X 20 / 4	←	←	←	US
	Industrial	Front	12.5 / 80 - 18	←	←	←	US/EU
		Rear	18.4 - 24 / 8	←	←	←	US/EU

3

Item			RX6020					
			RX6020C	RX6020PC	RX6020	RX6020P	RemARK	
Hydraulic system	Pump capacity	Total hydraulic flow lpm (cc/rev)	67.6 (26)	←	←	←		
		Implement lpm (cc/rev)	41.6 (16)	←	←	←		
		Power steering lpm (cc/rev)	26 (10)	←	←	←		
	Steering		Hydrostatic Power Steering	←	←	←		
	3 Point Lift Control Type		Position, Draft, Mixed Control	←	←	←		
	Standard remote valve quantity	Front joystick valve		1 (Port:4)	←	←	←	
		Rear remote hydraulic valve		1 (Port:2)	←	←	←	US/EU
				2 (Port:4)	←	←	←	AU
	3-point hitch		Category II	←	←	←		
	Max. lifting capacity	24 in. (610 mm) Behind lbs (kg.f)	3,594 (1,630)	←	←	←		
Lower link end lbs (kg.f)		4,575 (2,075)	←	←	←			
PTO	Rear	Type	Independent	←	←	←		
		P.T-O shaft	SAE 1-3/8, 6 Spline	←	←	←		
		Speed (PTO rpm)	540 / 540E	←	←	←		



Item		RX6020					
		RX6020C	RX6020PC	RX6020	RX6020P	RemARK	
Min. turning radius (with one rear wheel braked)	Agricultural	in. (mm)	118.9 (3,020)	←	←	←	US
			122.4 (3,110)	←	←	←	AU/EU
	Turf	in. (mm)	125.2 (3,180)	← (US)	← (EU)	← (EU)	
		Industrial	in. (mm)	129.9 (3,300)	← (US)	← (US/EU)	← (US/EU)
Weigh (Including cabin, excluding front weight)		lbs (kg.f)	5,732 (2,600)	←	-	-	US
			5,798 (2,630)	←	-	-	AU/EU
Max. Drawbar vertical load		lbs (kg.f)	1,655 (750)	←	←	←	
Automation system	Auto P.T.O		Std.	←	←	←	

※ The specifications are subject to change without notice.

[RX6620]

Item		RX6620					
		RX6620C	RX6620PC	RX6620	RX6620P	RemARK	
Engine	Model	4F243T-TMC4	4F243T-TPC4	4F243T-TMR4	4F243T-TPC4	US/EU	
		4F243T-TMC3	4F243T-TPC3	4F243T-TM2	4F243T-TP2	AU	
	Number of cylinders	4	←	←	←		
	Total displacement	cu in. (cc)	148.6 (2,435)	←	←	←	
	Bore and stroke	in. (mm)	3.4 x 4.0 (87 x 102.4)	←	←	←	
	Engine gross power	HP (kw)	66 (49.2)	←	←	←	
	P.T.O Power	HP (kw)	55 (41)	←	57.6 (43)	←	
	Rated revolution	rpm	2,600	←	←	←	
Capacities	Fuel tank	U.S.gal (L)	25.1 (95)	←	22.5 (85)	←	
	Transmission oil	U.S.gal (L)	15.9 (60)	←	←	←	
	Front axle oil	U.S.gal (L)	2.2 (8.5)	←	←	←	
Drive train	Clutch		Single Dry Clutch	Hydro Multi Wet Disc Clutch	Single Dry Clutch	Hydro Multi Wet Disc Clutch	
	Transmission	Shuttle	Synchro Shuttle	Power Shuttle	Synchro Shuttle	Power Shuttle	
		Main	Synchro mesh 4 stages	←	←	←	
		Range	Constant mesh 3 stages	←	←	←	US
		Speeds	12 X 12	←	←	←	US





Item			RX6620				RemARK
			RX6620C	RX6620PC	RX6620	RX6620P	
Drive train	Transmission	Range	Constant mesh 2 X 3 stages	←	←	←	EU/AU
		Speeds	24 X 24	←	←	←	EU/AU
	Ground speed [Tire for agricultural (AG)]	Forward mph (km/h)	0.97~21.51 (1.57~34.61)	←	0.98~22.59 (1.57~36.36)	←	US
		Reverse mph (km/h)	0.95~21.14 (1.54~34.03)	←	0.96~22.21 (1.54~35.75)	←	US
		Forward mph (km/h)	0.10~20.98 (0.16~33.76)	←	0.10~22.21 (0.16~35.75)	←	EU/AU
		Reverse mph (km/h)	0.10~20.63 (0.16~33.20)	←	0.10~22.21 (0.16~35.75)	←	EU/AU
	4-wheel drive		Hydro Multi Wet Disc Clutch	←	←	←	
	Quick Turn (QT)		NA	←	←	←	
	Brake		Wet Multi Disc	←	←	←	
Differential lock		Rear Standard	←	←	←		
Tires	Agricultural	Front	11.2 - 20	←	9.5 - 20	←	
		Rear	14.9 - 30	←	14.9 - 28	←	
	Turf	Front	31 X 13.5 X 15/8	←	←	←	US
		Rear	44 X 18 X 20/4	←	←(US/EU)	←(US/EU)	US
	Industrial	Front	12.5 / 80 - 18	←	←	←	US
		Rear	18.4 - 24 / 8	←	←	←	US

3

Item				RX6620					
				RX6620C	RX6620PC	RX6620	RX6620P	RemARK	
Hydraulic system	Pump capacity	Total hydraulic flow	lpm (cc/rev)	67.6 (26)	←	←	←		
		Implement	lpm (cc/rev)	41.6 (16)	←	←	←		
		Power steering	lpm (cc/rev)	26 (10)	←	←	←		
	Steering			Hydrostatic Power Steering	←	←	←		
	3 Point Lift Control Type			Position, Draft, Mixed Control	←	←	←		
	Standard remote valve quantity	Front joystick valve		1 (Port:4)	←	←	←		
		Rear remote hydraulic valve		1 (Port:2)	←	1 (Port:2)-US/ EU 2 (Port:4)-AU	←		
	3-point hitch			Category II	←	←	←		
	Max. lifting capacity	24 in. (610 mm) Behind		lbs (kg.f)	3,594 (1,630)	←	←	←	
		Lower link end		lbs (kg.f)	4,575 (2,075)	←	←	←	
PTO	Rear	Type		Independent	←	←	←		
		P.T.O shaft		SAE 1-3/8, 6 Spline	←	←	←		
		Speed(PTO rpm)		540 / 540E	←	←	←		



Item		RX6620				
		RX6620C	RX6620PC	RX6620	RX6620P	RemARK
Min. turning radius (with one rear wheel braked)	Agricultural in. (mm)	122.4 (3,110)	←	←	←	US
	Turf in. (mm)	125.2 (3,180)	← (US)	← (US/EU)	← (US/EU)	
	Industrial in. (mm)	129.9 (3,300)	← (US)	← (US/EU)	← (US/EU)	
Weight (Including cabin, excluding front weight)	lbs (kg.f)	5,798 (2,630)	←	-	-	
Max. Drawbar vertical load	lbs (kg.f)	1,655 (750)	←	←	←	
Automation system	Auto P·T·O	Std.	←	←	←	

※ The specifications are subject to change without notice.

[RX7320]

Item		RX7320					
		RX7320C	RX7320PC	RX7320	RX7320P	RemARK	
Engine	Model	4F243T-TMC4	4F243T-TPC4	4F243T-TMR4	4F243T-TPR4		
	Number of cylinders	4	←	←	←		
	Total displacement	cu in. (cc)	148.6 (2,435)	←	←	←	
	Bore and stroke	in. (mm)	3.4 x 4.0 (87 x 102.4)	←	←	←	
	Engine gross power	HP (kw)	73 (54.4)	←	←	←	
	P·T·O Power	HP (kw)	61.9 (46.2)	←	63(47)	←	
	Rated revolution	rpm	2,600	←	←	←	
Capacities	Fuel tank	U.S.gal (L)	25.1 (95)	←	22.5 (85)	←	
	Transmission oil	U.S.gal (L)	15.9 (60)	←	←	←	
	Front axle oil	U.S.gal (L)	2.2 (8.5)	←	←	←	
Drive train	Clutch		Single Dry Clutch	Hydro Multi Wet Disc Clutch	Single Dry Clutch	Hydro Multi Wet Disc Clutch	
	Transmission	Shuttle	Synchro Shuttle	Power Shuttle	Synchro Shuttle	Power Shuttle	
		Main	Synchro mesh 4 stages	←	←	←	
		Range	Constant mesh 3 stages	←	←	←	US
		Speeds	12 X 12	←	←	←	US



Item			RX7320				RemARK
			RX7320C	RX7320PC	RX7320	RX7320P	
Drive train	Transmission	Range	Constant mesh 2 X 3 stages	←	←	←	EU
		Speeds	24 X 24	←	←	←	EU
	Ground speed [Tire for agricultural (AG)]	Forward mph (km/h)	1.01~22.40 (1.63~36.04)	←	1.01~23.53 (1.63~37.86)	←	US
		Reverse mph (km/h)	1.00~22.02 (1.61~35.44)	←	1.0~23.13 (1.61.37.23)	←	US
		Forward mph (km/h)	0.11~21.85 (0.17~35.16)	←	0.11~23.53 (0.17~37.86)	←	EU
		Reverse mph (km/h)	0.11~21.48 (0.17~34.57)	←	0.11~23.13 (0.17~37.23)	←	EU
	4-wheel drive		Hydro Multi Wet Disc Clutch	←	←	←	
	Quick Turn (QT)		NA	←	←	←	
	Brake		Wet Multi Disc	←	←	←	
	Differential lock		Rear Standard	←	←	←	
Tires	Agricultural	Front	11.2 - 24	←	←	←	
		Rear	16.9 - 30	←	←	←	
	Turf	Front	31 X 13.5 X 15 / 8	←	NA	←	US
		Rear	44 X 18 X 20 / 4	←	NA	←	US
	Industrial	Front	12.5 / 80 - 18	←	←	←	US
		Rear	18.4 - 24 / 8	←	←	←	US

Item			RX7320				
			RX7320C	RX7320PC	RX7320	RX7320P	RemARK
Hydraulic system	Pump capacity	Total hydraulic flow lpm (cc/rev)	72.8 (28)	←	←	←	
		Implement lpm (cc/rev)	41.6 (16)	←	←	←	
		Power steering lpm (cc/rev)	31.2 (12)	←	←	←	
	Steering	Hydrostatic Power Steering	←	←	←		
	3 Point Lift Control Type	Position, Draft, Mixed Control	←	←	←		
	Standard remote valve quantity	Front joystick valve	1 (Port:4)	←	←	←	
		Rear remote hydraulic valve	1 (Port:2)	←	←	←	
	3-point hitch	Category II	←	←	←		
	Max. lifting capacity	24 in. (610 mm) Behind lbs (kg.f)	3,898 (1,768)	←	←	←	
		Lower link end lbs (kg.f)	4,974 (2,256)	←	←	←	
PTO	Rear	Type	Independent	←	←	←	
		P-T-O shaft	SAE 1-3/8, 6 Spline	←	←	←	
		Speed(PTO rpm)	540 / 540E	←	←	←	



Item			RX7320				RemARK
			RX7320C	RX7320PC	RX7320	RX7320P	
Min. turning radius (with one rear wheel braked)	Agricultural	in. (mm)	132.6 (3,370)	←	←	←	US
	Industrial	in. (mm)	-	-	129.9 (3,300)	←	EU
Weigh (Including cabin, excluding front weight)		lbs (kg.f)	6,162 (2,795)	←	-	-	
Max. Drawbar vertical load		lbs (kg.f)	1,655 (750)	←	1,985(900)	←	
Automation system	Auto P.T.O		Std.	←	←	←	

※ The specifications are subject to change without notice.

[RX7620]

Item		RX7620					
		RX7620C	RX7620PC	RX7620	RX7620P	RemARK	
Engine	Model	4F243T-TMC3	4F243T-TPC3	4F243T-TM2	4F243T-TP2		
	Number of cylinders	4	←	←	←		
	Total displacement	cu in. (cc)	148.6 (2,435)	←	←	←	
	Bore and stroke	in. (mm)	3.4 x 4.0 (87 x 102.4)	←	←	←	
	Engine gross power	HP (kw)	76 (56.7)	←	←	←	
	P.T.O Power	HP (kw)	63.9 (48)	←	65.5(49)	←	
	Rated revolution	rpm	2,600	←	←	←	
Capacities	Fuel tank	U.S.gal (L)	25.1 (95)	←	22.5 (85)	←	
	Transmission oil	U.S.gal (L)	15.9 (60)	←	←	←	
	Front axle oil	U.S.gal (L)	2.2 (8.5)	←	←	←	
Drive train	Clutch		Single Dry Clutch	Hydro Multi Wet Disc Clutch	Single Dry Clutch	Hydro Multi Wet Disc Clutch	
	Transmission	Shuttle	Synchro Shuttle	Power Shuttle	Synchro Shuttle	Power Shuttle	
		Main	Synchro mesh 4 stages	←	←	←	
		Range	Constant mesh 2 X 3 stages	←	←	←	
		Speeds	24 X 24	←	←	←	





Item				RX7620				
				RX7620C	RX7620PC	RX7620	RX7620P	RemARK
Drive train	Ground speed [Tire for agricultural (AG)]	Forward	mph (km/h)	0.11~21.85 (0.17~35.16)	←	0.11~23.53 (0.17~37.86)	←	
		Reverse	mph (km/h)	0.11~21.48 (0.17~34.57)	←	0.11~23.13 (0.17~37.23)	←	
	4-wheel drive			Hydro Multi Wet Disc Clutch	←	←	←	
	Quick Turn (QT)			NA	←	←	←	
	Brake			Wet Multi Disc	←	←	←	
	Differential lock			Rear Standard	←	←	←	
Tires	Agricultural	Front		11.2 - 24	←	←	←	
		Rear		16.9 - 30	←	←	←	
Hyd. system	Pump capacity	Total hydraulic flow	lpm (cc/rev)	72.8 (28)	←	←	←	
		Implement	lpm (cc/rev)	41.6 (16)	←	←	←	
		Power steering	lpm (cc/rev)	31.2 (12)	←	←	←	
	Steering			Hydrostatic Power Steering	←	←	←	
	3 Point Lift Control Type			Position, Draft, Mixed Control	←	←	←	
	Standard remote valve quantity	Front joystick valve			1 (Port:4)	←	←	←
				2 (Port:4)	←	←	←	

3

Item			RX7620				RemARK
			RX7620C	RX7620PC	RX7620	RX7620P	
Hyd. system	3-point hitch		Category II	←	←	←	
	Max. lifting capacity	24 in. (610 mm) Behind lbs (kg.f)	3,898 (1,768)	←	←	←	
		Lower link end lbs (kg.f)	4,974 (2,256)	←	←	←	
PTO	Rear	Type	Independent	←	←	←	
		P.T-O shaft	SAE 1-3/8, 6 Spline	←	←	←	
		Speed(PTO rpm)	540 / 540E	←	←	←	
Min. turning radius (with one rear wheel braked)	Agricultural	in. (mm)	132.6 (3,370)	←	←	←	
Weight (Including cabin, excluding front weight)		lbs (kg.f)	6,162 (2,795)	←	-	-	
Max. Drawbar vertical load		lbs (kg.f)	1,655 (750)	←	1,985 (900)	←	
Automation system	Auto P.T-O		Std.	←	←	←	

※ The specifications are subject to change without notice.

**NOISE LEVELS AS PERCEIVED BY THE OPERATOR**

The following tables give the noise level values, measured from the driver's seat in instantaneous conditions in compliance with standards EEC77/31(dBA) - annex II (without load) - and when driving by in compliance with standard EEC 74/151 (dBA).

<b>Tractors with Cabin</b>			
<b>model</b>	<b>Directive of The european Parliament and of the Council</b>	<b>Noise level at the operator's ear according to 2009/76/eC</b>	<b>Noise level in motion according to 2009/63/eC</b>
RX6020(C/PC) RX6620(C/PC) RX7320(C/PC) RX7620(C/PC)	2003/37/EC	87 dB(A)	81 dB(A)

3

※ Note: Data supplied by the manufacturer, approval values pending.

## VIBRATION Levels OF The TRACTOR eXPOSITION TO vIBRATIONS

### WARNING

- *The vibration level transmitted to the body as a whole depend on different parameters, some of them relating to the machine, others to the terrain and many specific for the operator. The prevailing parameters are the type of terrain or work surface and the ground speed.*
- *vibrations cause discomfort for the operator and in some cases put his/her health and safety at risk.*
- *make sure that the tractor is in good condition and that all routine servicing is correctly and regularly carried out.*
- *Check tire pressure and the steering and braking systems.*
- *Check that the operator's seat and adjustment systems are in good condition, then adjust the seat to the operator's weight and size.*

### ImPORTANT

- **More information on Whole Body Vibration (WBV) on agricultural tractors can be found in more specific publications and the relative risks can be taken into account following the laws of the country. In order to correctly estimate statistical values based on your daily work on the tractor, a specific measure instrument is required, such a three-axis accelerometer applied to the seat**

In accordance to EU Directive 78/764/EC the following table shows vibration levels measured on seats, in aws.

Operator's vibration level			
Seat type	Directive of The european Parliament and of the Council	Light-weight operator	heavy-weight opeartor
W08SS	78/764/EEC	0.83 m/s <sup>2</sup>	0.75 m/s <sup>2</sup>

\* aws = correct weighted value of the vibration acceleration (m/s<sup>2</sup>)

**TRAVeLING SPeED****[US 12X12]**

m/h (km/h)

OPeRATING The LeveR		FORWARD			ReveRSe		
RANGe	mAIN	RX6020	RX6620	RX7320	RX6020	RX6620	RX7320
Low	1	0.93 (1.51)	0.97 (1.57)	1.01 (1.63)	0.92 (1.49)	0.95 (1.54)	1.00 (1.61)
	2	1.24 (2.00)	1.28 (2.07)	1.33 (2.16)	1.22 (1.96)	1.26 (2.03)	1.31 (2.12)
	3	1.56 (2.52)	1.62 (2.61)	1.68 (2.72)	1.54 (2.48)	1.59 (2.57)	1.66 (2.67)
	4	2.17 (3.50)	2.25 (3.63)	2.35 (3.78)	2.14 (3.44)	2.22 (3.57)	2.31 (3.72)
Middle	1	2.84 (4.58)	2.95 (4.75)	3.07 (4.95)	2.80 (4.51)	2.90 (4.67)	3.03 (4.87)
	2	3.75 (6.04)	3.89 (6.26)	4.05 (6.52)	3.69 (5.94)	3.82 (6.16)	3.98 (6.41)
	3	4.73 (7.62)	4.91 (7.90)	5.11 (8.23)	4.65 (7.50)	4.82 (7.77)	5.03 (8.09)
	4	6.59 (10.60)	6.82 (10.99)	7.11 (11.44)	6.47 (10.42)	6.71 (10.80)	6.99 (11.25)
High	1	8.97 (14.44)	9.30 (14.97)	9.69 (15.59)	8.82 (14.20)	9.14 (14.72)	9.53 (15.33)
	2	11.82 (19.03)	12.26 (19.73)	12.77 (20.55)	11.63 (18.72)	12.05 (19.40)	12.56 (20.21)
	3	14.92 (24.02)	15.47 (24.90)	16.11 (25.93)	14.67 (23.62)	15.21 (24.49)	15.85 (25.50)
	4	20.74 (33.38)	21.51 (34.61)	22.40 (36.04)	20.39 (32.82)	21.14 (34.03)	22.02 (35.44)

3

[eU/AU 24X24]

m/h (km/h)

OPeRATING The LeveR		FORWARD				ReveRSe		
RANGe	mAIN	RX6020	RX6620	RX7320/7620	RX6020	RX6620	RX7320/7620	
L	Low	1	0.10 (0.16)	←	0.11 (0.17)	0.10 (0.16)	←	0.11 (0.17)
		2	0.13 (0.21)	←	0.14 (0.22)	0.13 (0.21)	←	0.14 (0.22)
		3	0.17 (0.27)	←	0.17 (0.28)	0.17 (0.27)	←	0.17 (0.28)
		4	0.23 (0.37)	←	0.24 (0.39)	0.23 (0.37)	←	0.24 (0.38)
	Mid- dle	1	0.30 (0.49)	←	0.32 (0.51)	0.30 (0.48)	←	0.31 (0.50)
		2	0.40 (0.65)	←	0.42 (0.67)	0.40 (0.64)	←	0.41 (0.66)
		3	0.51 (0.82)	←	0.53 (0.85)	0.50 (0.80)	←	0.52 (0.84)
		4	0.70 (1.13)	←	0.73 (1.18)	0.70 (1.12)	←	0.72 (1.16)
	High	1	0.94 (1.51)	←	0.98 (1.57)	0.92 (1.48)	←	0.96 (1.54)
		2	1.24 (1.99)	←	1.29 (2.07)	1.21 (1.95)	←	1.26 (2.03)
		3	1.56 (2.51)	←	1.62 (2.61)	1.53 (2.47)	←	1.60 (2.57)
		4	2.17 (3.49)	←	2.26 (3.63)	2.13 (3.43)	←	2.22 (3.57)



m/h (km/h)

OPeRATING The LeveR		FORWARD			ReveRSe			
RANGe	mAIN	RX6020	RX6620	RX7320/7620	RX6020	RX6620	RX7320/7620	
H	Low	1	0.98 (1.57)	←	1.01 (1.63)	0.61 (1.54)	←	1.00 (1.61)
		2	1.29 (2.07)	←	1.34 (2.16)	1.26 (2.03)	←	1.32 (2.12)
		3	1.62 (2.61)	←	1.69 (2.72)	1.60 (2.57)	←	1.66 (2.67)
		4	2.26 (3.63)	←	2.35 (3.78)	2.22 (3.57)	←	2.31 (3.72)
	Mid- dle	1	2.95 (4.75)	←	3.08 (4.95)	2.90 (4.67)	←	3.03 (4.87)
		2	3.89 (6.26)	←	4.05 (6.52)	3.83 (6.16)	←	3.98 (6.41)
		3	4.91 (7.90)	←	5.11 (8.23)	4.83 (7.77)	←	5.03 (8.09)
		4	6.83 (10.99)	←	7.11 (11.44)	6.71 (10.80)	←	6.99 (11.25)
	High	1	9.07 (14.60)	←	9.45 (15.21)	8.92 (14.36)	←	9.29 (14.95)
		2	11.96 (19.25)	←	12.46 (20.05)	11.76 (18.93)	←	12.25 (19.71)
		3	15.09 (24.29)	←	15.72 (25.30)	14.84 (23.88)	←	15.45 (24.87)
		4	20.98 (33.76)	←	21.85 (35.16)	20.63 (33.20)	←	21.48 (34.57)

3

## ImPLemeNT LImITATIONS STANDARD SIZE BY ImPLemeNT

ImPLemeNT	DeSCRIPTION	RX6020	RemARKS
1. Loader	Max. Bucket width	Below 84.0 (2,134)	
2. Backhoe with sub frame	Max. Digging depth	Not use	Do not use 3 - point hitch backhoe
3. Mid Mower	Max. width	Not use	
4. Tiller	Max. width	Not use	
5. Box Blade	Max. width	Below 84.0 (2,134)	
6. Rear Blade	Max. width	Below 84.0 (2,134)	Use it only to lowest top link hole
7. Rotary Cutter	Max. width	Below 84.0 (2,134)	
8. Aerator	Max. width	Below 84.0 (2,134)	
9. Landscape Rakes	Max. width	Below 84.0 (2,134)	





## DeSCRIPTION OF OPeRATING SYSTem

**eXTeRIOR vleW (CABIN) ..... 4-3**

**eXTeRIOR vleW (ROPS) ..... 4-4**

**SWITCh mOUNTING LOCATIOn ..... 4-5**

KEY SWITCH ..... 4-7

COMBINATION SWITCH ..... 4-8

HAZARD LAMP SWITCH ..... 4-9

4WD SWITCH..... 4-10

PTO SWITCH ..... 4-12

PTO SELECTION SWITCH..... 4-13

REGENERATION UNDERWAY BUTTON .. 4-13

CLUTCH PEDAL ENGAGEMENT  
CONTROL BUTTON..... 4-14

PTO CRUISE..... 4-15

CALIBRATION SWITCH..... 4-16

**INSTRUMENT PANeL ..... 4-17**

TACHOMETER/HOURMETER ..... 4-18

FUEL GAUGE..... 4-18

ENGINE COOLANT TEMPERATURE GAUGE ... 4-19

TURN SIGNAL LAMP ..... 4-20

BATTERY CHARGING LAMP ..... 4-20

HEAD LIGHT HIGH BEAM LAMP ..... 4-20

GLOW PLUG INDICATOR ..... 4-21

ENGINE OIL PRESSURE WARNING LAMP .. 4-21

DIFFERENTIAL LOCK WARNING LAMP .. 4-22

AIR FILTER WARNING LAMP..... 4-22

QUICK / TURN WARNING LAMP  
(IF EQUIPPED)..... 4-22

4WD INDICATOR ..... 4-23

FORWARD INDICATOR ..... 4-23

NEUTRAL INDICATOR ..... 4-23

REVERSE INDICATOR ..... 4-24

PTO INDICATOR..... 4-24

PARKING BRAKE WARNING LAMP..... 4-24

LOW FUEL LEVEL WARNING INDICATOR ... 4-25

COOLANT TEMPERATURE WARNING LAMP.. 4-25

WATER IN FUEL WARNING LAMP ..... 4-25

REGENERATION WARNING LAMP ..... 4-26

REGENERATION UNDERWAY LAMP ..... 4-26

ENGINE CHECK WARNING LAMP ..... 4-26

CRUISE PTO WARNING LAMP ..... 4-27

BRAKE (ONE SIDE) LAMP ..... 4-27

# 4

4



## DeSCRIPTION OF OPeRATING SYSTEm

### **OPeRATING The CONTROLS ..... 4-28**

MAIN SHIFT LEVER.....	4-31
RANGE GEAR SHIFT LEVER.....	4-31
SHUTTLE SHIFT LEVER .....	4-32
PTO SHIFT LEVER .....	4-33
CLUTCH PEDAL .....	4-34
BRAKE PEDAL.....	4-35
STEERING WHEEL ADJUSTMENT.....	4-35
PARKING BRAKE LEVER .....	4-36
FOOT THROTTLE .....	4-37
HAND THROTTLE LEVER.....	4-37
DIFFERENTIAL LOCK PEDAL.....	4-38
SEAT ADJUSTMENT.....	4-38
POSITION CONTROL LEVER .....	4-41
DRAFT CONTROL LEVER.....	4-42
JOYSTICK LEVER .....	4-42
LIFTING ARM (LOWER LINK) SPEED CONTROL KNOB .....	4-43
DOUBLE ACTING LEVER.....	4-43

### **CABIN SYSTEm ..... 4-45**

INTERIOR DEVICES.....	4-45
EXTERIOR DEVICES.....	4-47
ENTRANCE .....	4-47
REAR WINDOW .....	4-48
SIDE WINDOW.....	4-48
WORKING LIGHT.....	4-49
WIPER .....	4-49
RADIO CASSETTE/CD PLAYER (IF EQUIPPED).....	4-50
ANTENNA.....	4-51
CABIN LAMP .....	4-51
ACCESSORY .....	4-52
SUN VISOR (IF EQUIPPED).....	4-53
RECIRCULATION/FRESH AIR MODE.....	4-53
HEATER AND AIR CONDITIONER .....	4-54
7-PIN POWER OUTPUT SOCKET .....	4-57
TIRES, WHEELS AND BALLAST.....	4-58
INFLATION PRESSURE .....	4-59
TREAD.....	4-60
WHEEL TORQUE AND DIRECTION.....	4-64
ADDITIONAL WEIGHT .....	4-65
MASS(ES) AND TIRE(S).....	4-68



### eXTeRIOR vIeW (CABIN)

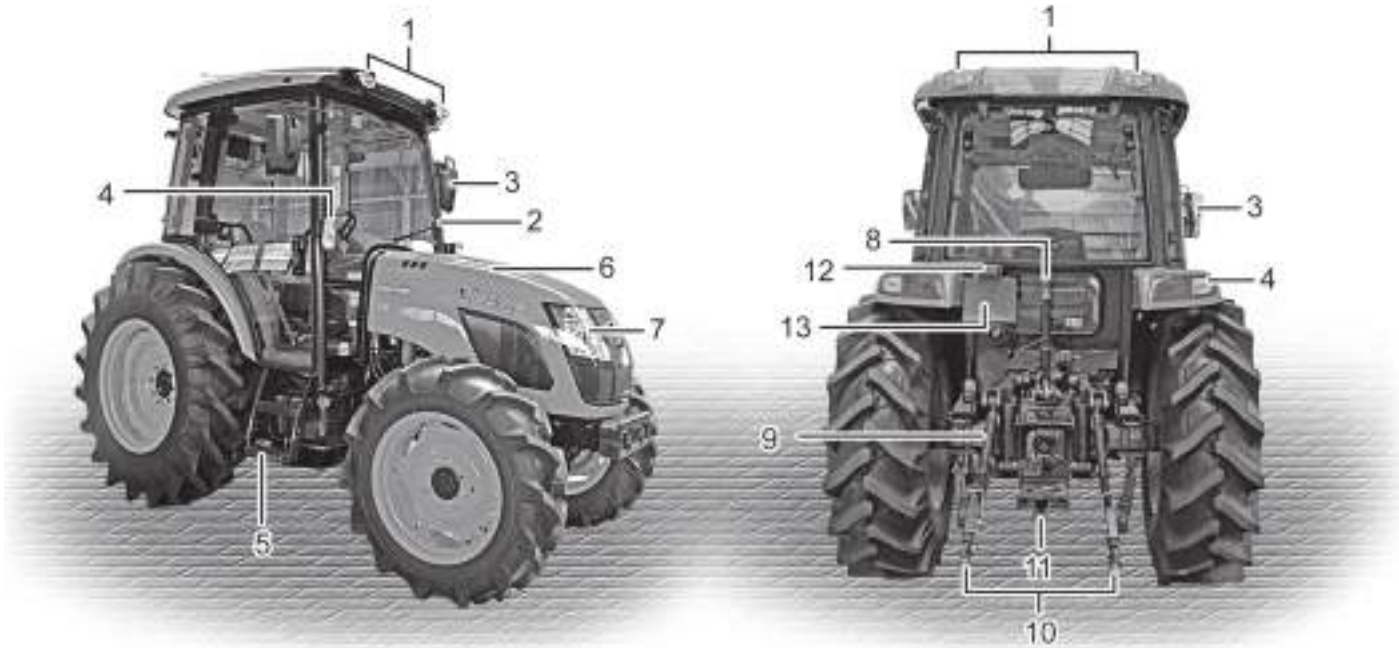

4

- (1) Working Lamp
- (2) Wiper
- (3) Rear View Mirror
- (4) Turn Signal Lamp
- (5) Step

- (6) Bonnet
- (7) Head Lamp
- (8) Top Link
- (9) Lift Rod
- (10) Lower Link

- (11) Draw Bar
- (12) Backup Lamp
- (13) License Plate Bracket

T110443A





## eXTeRIOR vIeW (ROPS)

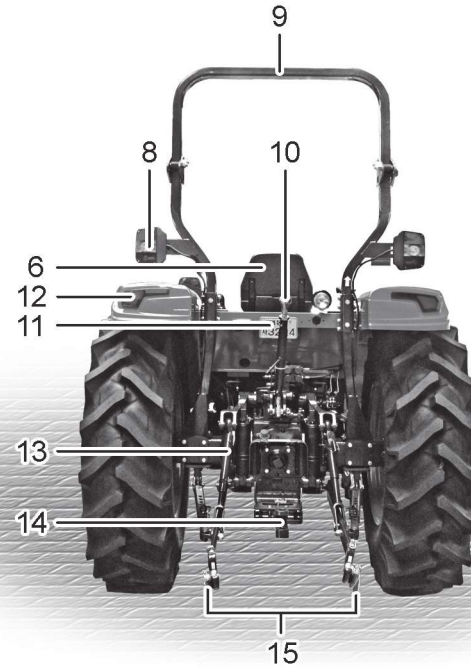

- (1) Steering Wheel
- (2) Rear View Mirror
- (3) Bonnet
- (4) Head Lamp
- (5) Step

- (6) Seat
- (7) Joy-stick Lever
- (8) Combination Lamp
- (9) ROPS
- (10) Top Link

- (11) License Plate
- (12) Rear Lamp
- (13) Lift Rod
- (14) Draw Bar
- (15) Lower Link





## SWITCH mOUNTING LOCATION

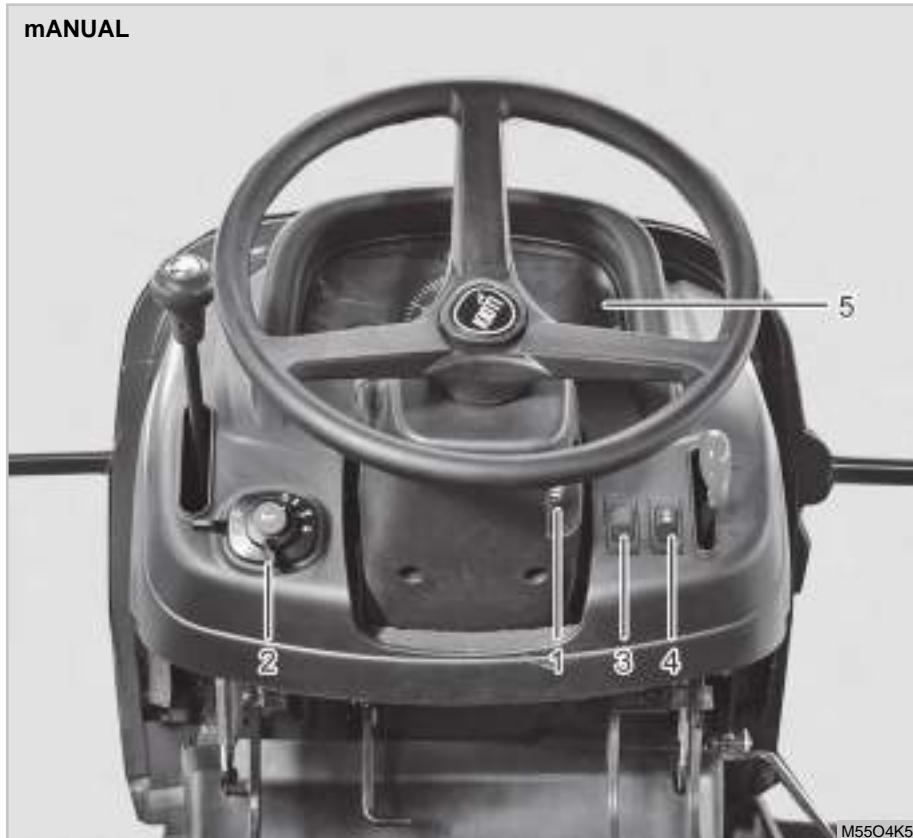

- (1) Key Switch
- (2) Combination Switch
- (3) Hazard Lamp Switch
- (4) Driving Mode Selection Switch
- (5) Instrument Panel

4



### POWeR ShUTTLe

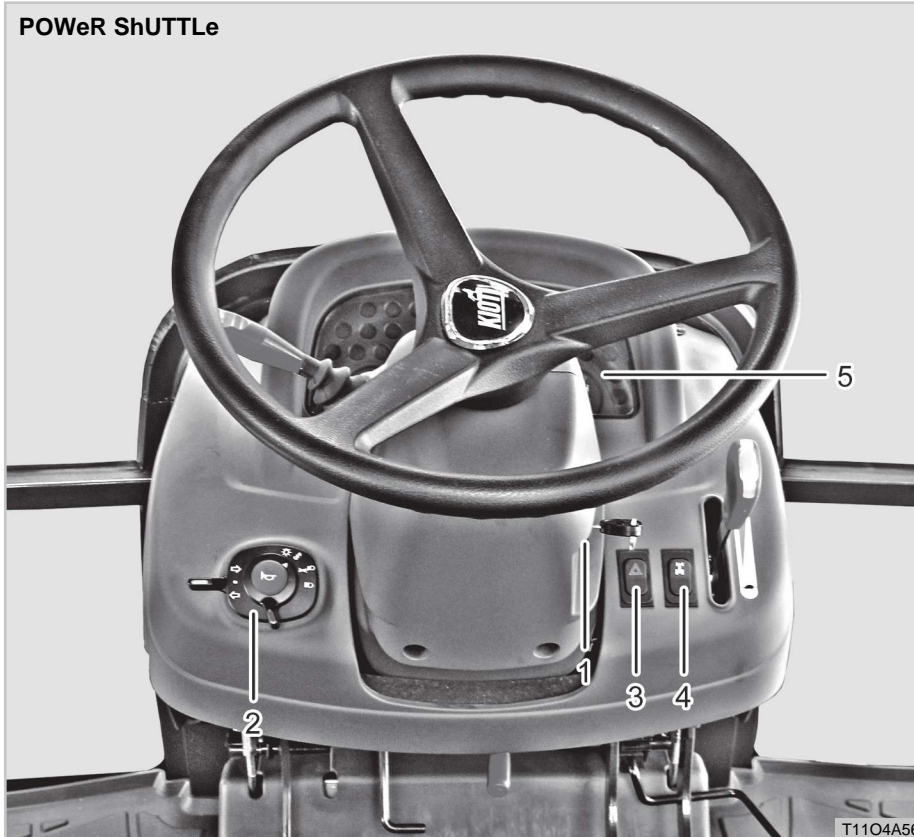

- (1) Key Switch
- (2) Combination Switch
- (3) Hazard Lamp Switch
- (4) Driving Mode Selection Switch
- (5) Instrument Panel

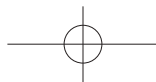

## Key SWITCH

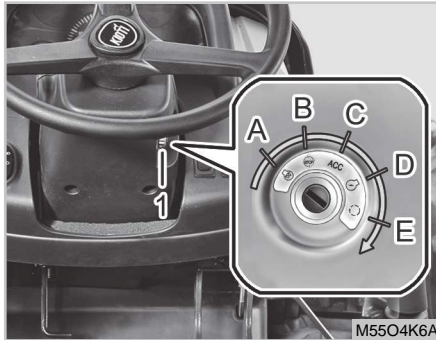

(1) Key Switch (A) Pre-heat (B) Stop  
(C) ACC (D) ON (E) Start

-  (A)  
The position "A" indicates the "manual preheat". This position is a self-return type, so the key should be held there while pre-heating. The pre-heating indication lamp on the dash board will turn on at the same time. **Pre-heating more than 30 seconds consecutively can reduce the preheat system's life.**

-  (B)  
When the key switch is in position "B", the engine and all electrical devices in the vehicle are turned off.

However flasher lights and turn signal lights can be operated along with their indication lamps on the dash board.

- ACC (C)  
When the key switch is turned to the position "C", brake lights, flasher lights and turn signal lights can be operated.
-  (D)  
The position "D" indicates the "ON" position. As soon as the key switch is turned to this position, the oil pressure warning lamp and battery charge warning lamp comes on (These turn off after the engine is started).

### NOTE

- **The pre-heating operation will automatically be activated in this position "D" (ON). The automatic preheat operation is indicated by the glow plug indicator. make sure to preheat the engine until the glow plug indicator goes off (approx. 8 seconds) in cold weather.**

-  (E)  
The position "E" indicates "Start". In order to start the engine, depress the clutch pedal and turn the PTO switch off.  
As soon as the engine is started, release the key then the key will return to the position "D".

### ⚠ CAUTION

- Stop the engine immediately if the oil pressure warning lamp does not go off after the engine is started. The engine may be severely damaged.
- If the battery charge warning lamp does not go off after the engine is started, check the electrical systems, such as the alternator, for damage. Continuing to use the engine under this condition can discharge the battery or damage other electrical devices.

### 📖 NOTE

- The ignition key is not directional and can be inserted in any direction. Also, be careful not to leave the tractor unattended with the key in the tractor.
- The horn, turn signal lamp, and hazard lamp can be operated without the key inserted.

## COMBINATION SWITCH



- (1) Turn Signal Light Switch  
(2) Head Light Switch      (3) Horn Switch

The combination switch consists of the head light, turn signal light, and horn switches. Its function by its position is as follows:

- OFF : Head light and tail light OFF  
 ☰○ : Low beam and tail light ON  
 ☷○ : High beam ON  
 ⇄ : Turn signal light and tail light ON

## HEAD LIGHT SWITCH



- (1) Head Light Switch  
(A) OFF      (B) Low Beam ON  
(C) High Beam ON

The head light switch can be operated only while the key switch is in "ON" position. Turning the head light switch clockwise one click will illuminate the low beam head lights while turning it one more click will illuminate the high beam head lights.

### ⚠ WARNING

- **Driving with high beam head light disturbs the approaching vehicle's visibility for safe driving. Use the high beam head lights only if necessary.**



**TURN SIGNAL LIGHT SWITCH**

(1) Turn Signal Light Switch  
 (A) Right Turn (B) Left Turn

The turn signal lights are used when turning the vehicle left or right. Pulling the lever up blinks the right turn signal light while pushing the lever down blinks the left turn signal light.

**NOTE**

- The turn signal light lever is not the self-return type. Therefore, make sure to return the lever manually after turning the vehicle.
- The turn signal lamps can be operated without the key inserted.

**HORN SWITCH**

(1) Horn Switch

The horn switch can be operated without the key inserted. Pressing this switch sounds the horn.

**hAZARD LAmP SWITCH**

(1) Hazard Lamp Switch  
 (A) ON (B) OFF

This switch can be used to warn other vehicles when malfunction occurs in the tractor while driving on a public road. Pressing this switch up blinks the hazard lamp and returning it turns off the lamp. The turn signal lights cannot be operated while this switch is pressed up to operate the hazard lamps.

**CAUTION**

- If the hazard lamps are turned on for an extended period of time while the engine is stopped, the battery can be discharged. Therefore, use them only in emergency.
- The hazard lamp can be operated without the key inserted.

**4WD SWITCH**

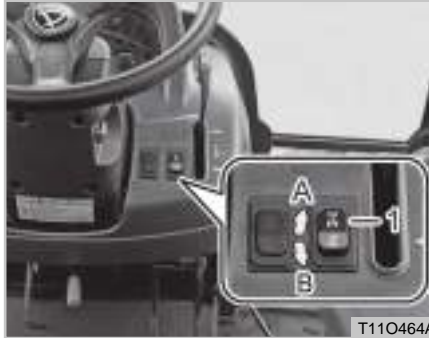

(1) Driving mode selection switch  
 (A) 4WD (B) Quick Turn (If equipped)

Operate this switch to select the 4WD (4-Wheel Drive) and QT (Quick Turn) driving modes. Pressing its upper part selects the 4WD mode while pressing its lower part selects the quick turn mode. Each driving mode has the following function:

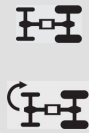
SWITCH	TURNING	LAMP
2WD	Normal turning	Lamp OFF
4WD	Normal turning	4WD lamp ON
QT	If the steering angle of the front wheels is over 35 degrees during turning, the front wheels rotate 2 times faster than the rear wheels for a sharp turn.	QT lamp ON 

The 4WD (4 Wheel Driving) is to increase traction by driving four wheels. It is hydraulically operated by a simple switch operation.

To engage the 4WD, press the switch up. To disengage it, return the switch.

The 4WD function can be used under the following conditions:

1. If high traction is needed in a wet area
2. When towing a trailer or using a loader



3. When working on a sandy surface
4. When the tractor is pushed out by reaction from the implement during cultivating on a hard surface.
5. When cultivating a field or driving over a bank

 **CAUTION**

To avoid accident:

- engage the switch only when the vehicle is stationary.
- While the 4WD is engaged, drive the vehicle with low speed as steering and braking characteristics may differ.
- It is possible to engage the 4WD during driving. however, you may hear noise or feel slight shift or impact at times in this case. For safe driving, engage the 4WD when the tractor is stationary.
- The 4WD should not be used on a paved road as tires can be worn faster and could cause damage to front axle.

### HOW TO USE QUICK-TURN FUNCTION

1. To activate the quick-turn function, press the switch downward.
2. When operating the switch to activate the quick-turn function, make sure that the front wheels are in the straight ahead position.

 **CAUTION**

- The quick-turn function is useful when working with a rotary in field. however, be cautious during its use as its misuse can cause rollover. Never use this function during driving. Also, never use it on a steep slope and sharp corner.
- As a safety measure, the quick-turn function cannot be activated when the range shift lever is set to the high speed position and the vehicle speed is over 6 km/h.
- make sure to set the switch to the 2WD or 4WD position before leaving the field.

 **CAUTION**

- Be sure to select the 2WD during driving, as 4WD or quick-turn can cause an unexpected accident during driving.
- Never make a sharp turn during driving.
- If your work requires mid to high load applied to the front loader or four wheels, using the quick-turn function can damage the quick-turn clutch disc or wear it prematurely. Therefore, never use the quick-turn function under this condition.

## PTO SWITCH

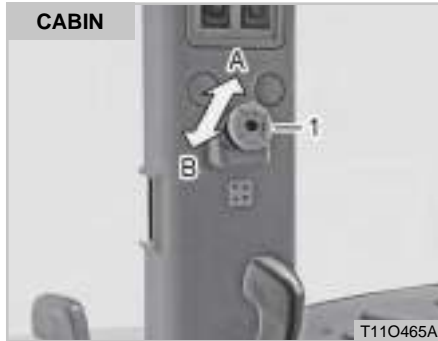

(1) PTO Switch  
 (A) - "ON"      (B) - "OFF"

The PTO switch is used to supply power from the tractor to the implement.

**make sure to put this switch into the "OFF" position before starting the engine. Otherwise, the engine cannot be started.**

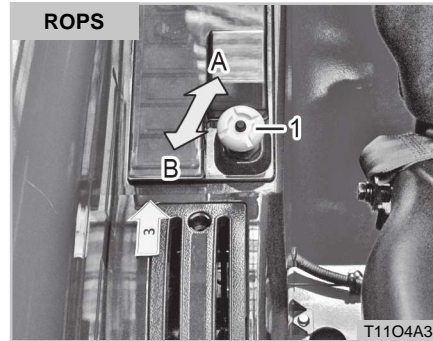

(1) PTO Switch  
 (A) - "ON"      (B) - "OFF"

The rear PTO rotates at 540 rpm when the engine speed is approx. 2,444 rpm.

### CAUTION

To avoid personal injury and accident:

- Before disassembling or cleaning the PTO system, make sure that the PTO switch is in the "OFF" position, the engine is stopped, and all parts are stopped.
- Always keep the PTO driving part clean. Also, check the PTO cover is closed while PTO is in operation.
- Disengage the PTO while driving the tractor on the public road.
- Be careful not to get your hand, foot, cloth, or hair into any driving part while the PTO is in operation. You can be severely injured or killed!
- make sure that no one is around the tractor and implement while the PTO is in operation.



## PTO SeLeCTION SWITCH



(1) PTO Selection Switch  
(A) AUTO (B) MANUAL

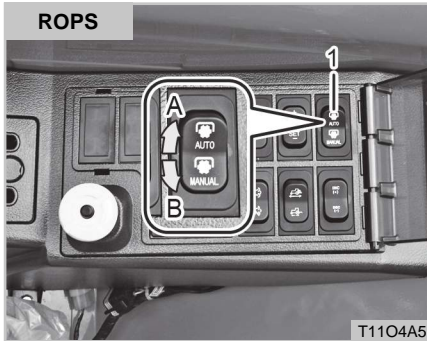

(1) PTO Selection Switch  
(A) AUTO (B) MANUAL

This switch is to switch between the automatic and manual PTO operations. In the manual operation, the PTO rotates regardless of the height of the implement. In the automatic operation, the PTO stops rotating as the implement is raised.

## ReGeNeRATION UNDeR WAY BUTTON



(1) Regeneration Underway Lamp  
(A) Activation (B) Deactivation

### ACTivATION (UPPeR BUTTON)

Perform the following procedure when the regeneration warning lamp comes on :

1. Park the vehicle on level ground
2. Run the engine at the idle speed.
3. Depress the brake pedal and lock it in place.
4. Run the engine 3 to 4 minutes. Then, press the regeneration button.

### CLUTCh PeDAL eNGAGe- meNT CONTROL BUTTON

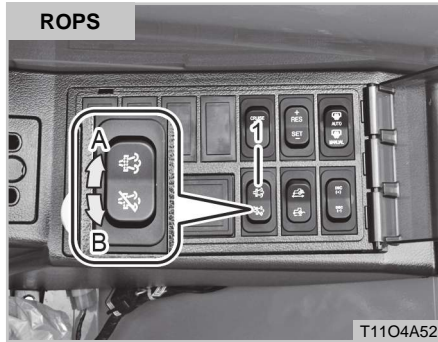

(1) Regeneration Underway Lamp  
(A) Activation (B) Deactivation

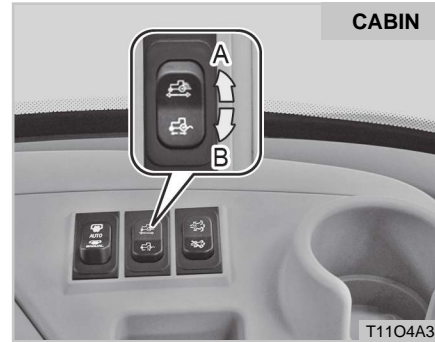

(A) FAST (B) SLOW

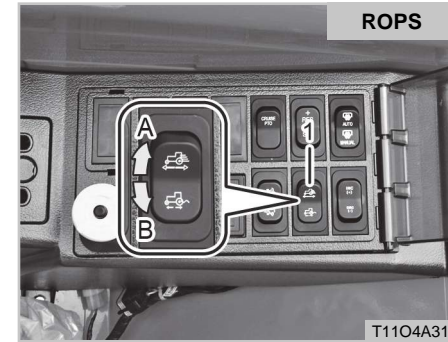

(A) FAST (B) SLOW

5. The regeneration underway lamp will illuminate. Wait until regen has been completed in approximately 10 minutes to resume operation after the light turns off.

#### DeACTivATION (LOWeR BUTTON)

Do not press the deactivation button during the regeneration process.

However, in an emergency, press the deactivation button to stop the regeneration process.

The engagement height of the clutch pedal can be adjusted with this button and this function is only available for the power shuttle model.

Pressing the upper portion of the button speeds up the clutch engagement operation while pressing its lower portion slows down the clutch engagement operation.

## PTO CRUISE

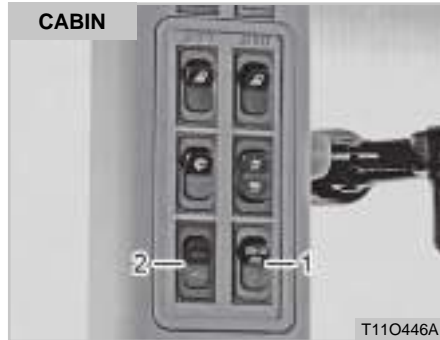

- (1) PTO Cruise  
(2) PTO Setting Switch

Activating the PTO cruise function during work can keep the PTO speed constant for enhanced operating condition.

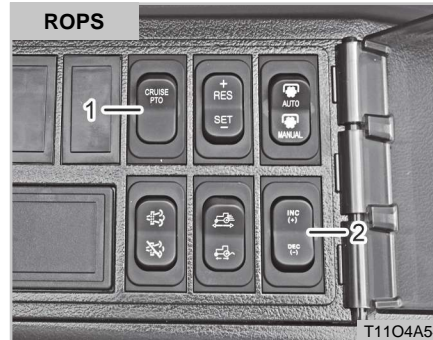

- (1) PTO Cruise  
(2) PTO Setting Switch

### PTO CRUISE ACTIVATION

Run the engine at a speed over 1,300 RPM. With the brake and clutch pedals released, set the PTO cruise switch to the ON position and press the SET (1) portion of the cruise activation switch

The cruise setting switch can be operated as follows while the PTO cruise function is activated.

- RES(+): Speed is increased by 50 RPM when pressing it.
- SET(-): Speed is decreased by 50 RPM when pressing it.

### PTO CRUISE DeACTiv ATION

Depress the brake pedal or clutch pedal or set the PTO cruise switch to the "OFF" position to deactivate the PTO cruise function.

If the PTO cruise function is deactivated by depressing the brake or clutch pedal with the PTO cruise switch set in the "ON" position, pressing the RES(+) switch once resumes the previous PTO activation setting.

#### ⊕ ImPORTANT

- If the brake pedals are not connected to each other, depressing the brake pedal does not deactivate the PTO cruise function.

### CALIBRATION SWITCH



(1) Calibration Switch

This switch is for calibration of shuttle lever and clutch pedal. if any calibration is required please contact **KIOTI** dealer at your earliest convenience.



(1) Calibration Switch



## INSTRUMENT PANEL

Symbols on the instrument panel come on when the key switch is turned to the "ON" position.

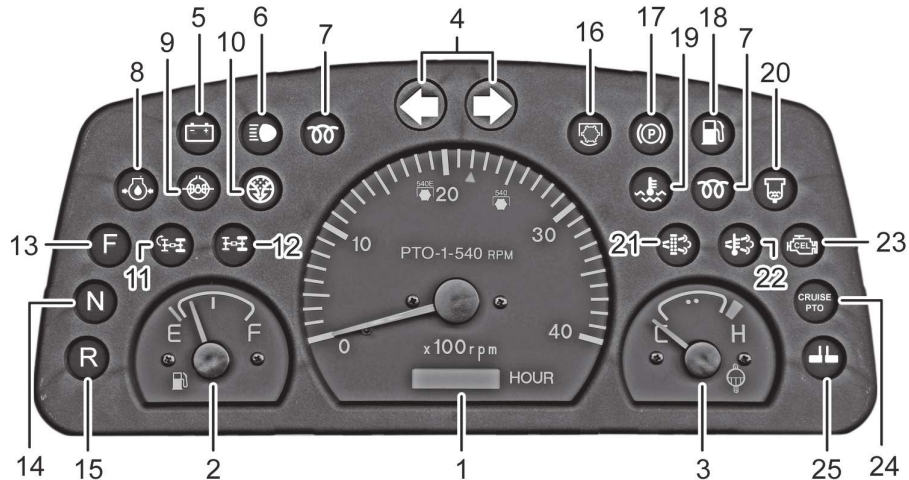

T110467B

- (1) Tachometer / Hourmeter
- (2) Fuel Gauge
- (3) Engine Coolant Temperature Gauge
- (4) Turn Signal Lamp
- (5) Battery Charging Lamp
- (6) Head Light High Beam Lamp
- (7) Glow Plug Indicator
- (8) Engine Oil Pressure Warning Lamp
- (9) Differential Lock Warning Lamp
- (10) Air Filter Warning Lamp
- (11) Quick / Turn Warning Lamp (If equipped)
- (12) 4wd Indicator
- (13) Forward Indicator
- (14) Neutral Indicator
- (15) Reverse Indicator
- (16) PTO Indicator
- (17) Parking Brake Warning Lamp
- (18) Low Fuel Level Warning Indicator
- (19) Coolant Temperature Warning Lamp
- (20) Water In Fuel Warning Lamp
- (21) Regeneration Warning Lamp
- (22) Regeneration Underway Lamp
- (23) Engine Check Warning Lamp
- (24) Cruise PTO Warning Lamp
- (25) Brake (One Side) Lamp

### TACHOMETER/hOURMETER



(1) Tachometer (2) Hourmeter Indicator  
(3) Rated Engine Speed Indicator

The tachometer indicates the engine rpm.

The mark "▲"(3) indicates approx. engine rated speed. You can have the 540 PTO rpm while the engine speed is around this indicator.

For speedy and effective work, adjust the work load so that the engine rpm is close to this mark "▲".

The hourmeter does not operate if the engine is stopped even if the key switch is in the "ON" position.

### eCO PTO

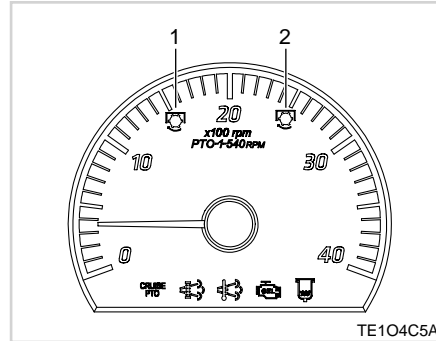

(1) 540 Eco rpm (2) 540 rpm

The PTO speed can be selected as desired according to the working condition.

The speed 2(☐) corresponds to the engine speed for the mid range load to achieve 540 PTO RPM while the speed 1(☐) corresponds to the engine speed for the light range load to achieve 540 PTO RPM. Set the engine speed around this mark for efficient and rapid work.

### FUEL GAUGE



(1) Fuel Gauge  
"E": Empty "F": Full

This gauge indicates the remaining fuel level after the key switch is turned to the "ON" position.

**F** : Fuel is fully filled.

**e** : Replenish the fuel tank.

If driving is continued with the needle below the position "E", air may enter the fuel supply system. In this case, "bleed" the system. (For detailed instructions, refer to "Bleeding fuel system" in the chapter "Maintenance")

## eNGINE COOLANT TemPeRATURE GAUGE

### ⚠ WARNING

- *This indicator comes on when the fuel level in the tank is low. Therefore replenish the fuel immediately when the needle approaches the "e" position.*

### 📖 NOTE

- Make sure to use only correct fuel as the engine can be damaged if unqualified fuel is used.
- Use fuel for winter season in cold weather to start the engine easier.
- The gauge needle can move on a hill as fuel slopes in the tank.



(1) Coolant Temperature Gauge  
 (2) Normal Temperature Range  
 "C": Cold "H": Hot

This gauge indicates the coolant temperature after the key switch is turned to the "ON" position.

**C** : Coolant is cold.

**h** : Coolant is hot.

The range marked in "2" in the figure indicates the normal engine temperature (normal driving range).

### ⚠ CAUTION

- **make sure to control the work load so that the needle is not in the red zone.**
- **IF The NeedLe STAYS IN The ReD ZONE, DO NOT STOP The eNGINE ImmeDIATe LY. IN-STeAD, ReD UCe The WORK LOAD TO COOL DOWN The eNGINE BeFORe STOPPING The eNGINE.**
- **make sure to keep the front grill clean so that air is sucked through it freely for fast cooling.**

### TURN SIGNAL LAMP

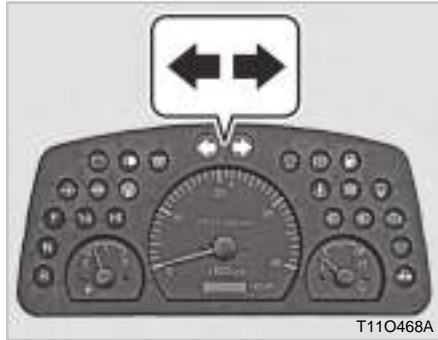

T11O468A

Operating the turn signal lamp switch up and down turns on the corresponding lamp in green.

### BATTERY CHARGING LAMP

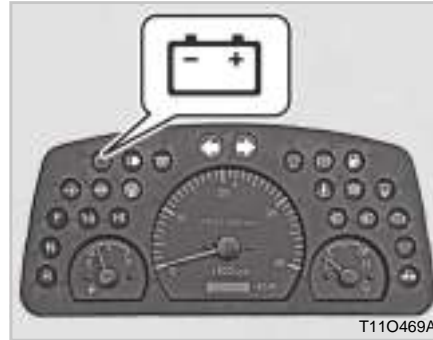

T11O469A

This lamp is turned On when the starting switch is turned On before starting the engine but turned Off after starting the engine.

#### CAUTION

- If this warning lamp comes on while driving, the charging system, such as the alternator, is malfunctioning. Therefore, turn off all electrical devices and have the tractor checked by your local KIOTI Dealer or workshop as soon as possible.

### HEAD LIGHT HIGH BEAM LAMP



T11O470A

This lamp comes on in blue when the high beam head light is switched on. Driving with high beam head light disturbs an approaching vehicle's visibility. For safe driving, use the high beam head light only if necessary.

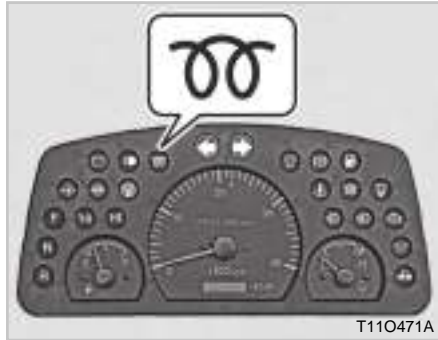
**GLOW PLUG INDICATOR**

This indicates the operating condition of the preheat system. In case the auto pre-heating kit is installed, this indicator comes on 8 seconds when the key switch is turned to the "ON" position. In case of basic model, this indicator comes on when the key is held in "PRE-HEAT" position by operator.

**eNGINE OIL PReSSURE WARNING LAMP**

This lamp comes on when the engine oil pressure or oil level is low.

This lamp is turned On when the starting switch is turned On before starting the engine but turned Off after starting the engine. If this lamp comes on while driving, stop the engine immediately and check the engine oil level.

If this lamp comes on even with the specified engine oil level, have the tractor checked by your local **KIOTI** dealer or workshop immediately.

**CAUTION**

- If the oil level is below the specified range, the engine can seize.
- The engine can be severely damaged if driving or operating the tractor with the engine oil warning lamp ON.

### DIFFeReNTIA L LOCK WARNING LAmP



This comes on when the differential lock is engaged.

### AIR FILTeR WARNING LAmP



This lamp illuminates when the air filter is clogged by dust etc.

### QUICK / TURN WARNING LAmP (IF eQUIPPeD)

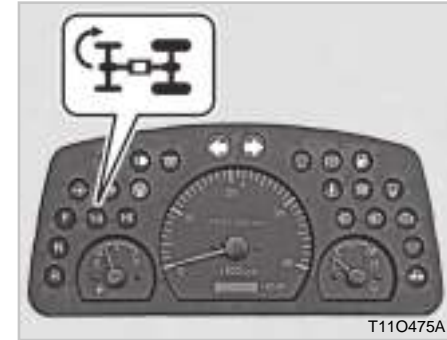

This comes on when the driving mode selection switch is set to the quick-turn mode.



### 4WD INDICATOR



This comes on to indicate 4WD engagement.

The 4WD indicator is turned off temporarily while the quick turn mode is in operation.

#### CAUTION

- The durability of the axle can be deteriorated if only one brake pedal is depressed while the 4WD is activated.

### FORWARD INDICATOR



If the shuttle lever is in forward position, this lamp turns in green.

### NeUTRAL INDICATOR



If the shuttle lever is in neutral position, this lamp turns in green.

### ReveRSe INDICATOR

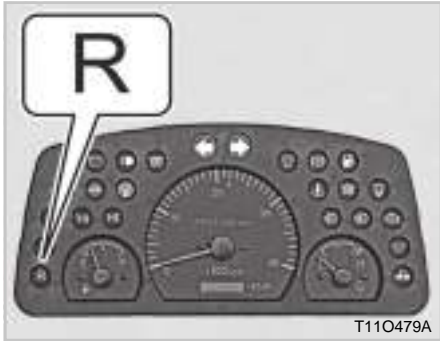

If the shuttle lever is in reverse position, this lamp turns in green.

### PTO INDICATOR

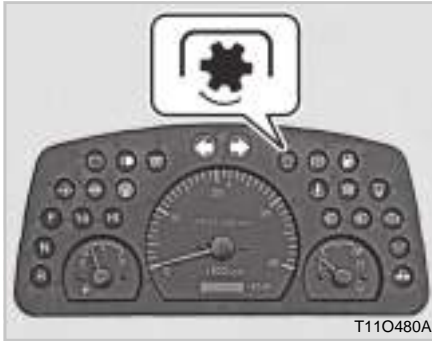

This indicator shows the PTO engagement condition. When the PTO is engaged, this indicator comes on. When the PTO clutch is disengaged, this indicator goes off.

**⚠ CAUTION**

- Set the PTO switch to the "OFF" position in order to start the engine.

### PARKING BRAKe WARNING LAmP



When the parking brake is actuated, the lamp lights "ON".

**⚠ CAUTION**

- If this indicator is ON even with the parking brake released, have the tractor checked by your local KIOTI dealer or workshop immediately.
- If you drive with parking brake locked, a warning lamp will turn on and off on the buzzer. (For the tractor with power shuttle)



### LOW FUEL Level WARNING INDICATOR



This indicator comes on when the fuel level in the tank is low. If driving the vehicle until running out of fuel, the engine and fuel system can be damaged. When this indicator comes on, add fuel immediately.

#### CAUTION

- If the fuel is empty, the warning indicator will turn on and off with the buzzer on the panel.
- After 30 seconds, just the indicator will stay on until filling with fuel.

### COOLANT Temperature WARNING Lamp



If the coolant temperature is 239°F or above 239°F (115°C) for more than 5 seconds, buzzer is heard and lamp is turned on. Stop the engine, contact a **KIOTI** dealer immediately.

### Water IN Fuel WARNING Lamp



The warning buzzer sounds when (approx. 45 cc) of water is accumulated in the fuel filter. In this case, stop the engine immediately and drain water from the fuel filter.

### ReGeNeRATIOn WAReNing LAmP



If carbon is accumulated in the exhaust catalytic filter, the warning lamp comes on or blinks.

If this lamp comes up, push down the "Regeneration" button. (Refer to the page 4-12)

### ReGeNeRATIOn UNDeRWAY LAmP

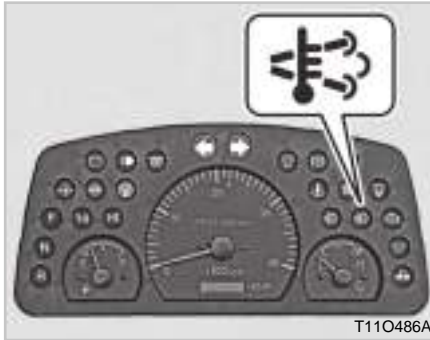

This lamp on when regeneration is needed in DPF.

#### **⚠ WARNING**

- ***When on regeneration, Don't touch the part of DPF because it is very hot around DPF.***

### eNGINe CheCk WAReNing LAmP



This lamp on when any major electric device or engine fuel system is malfunctioning.

**CRUISe PTO WARNING LAmP**

This switch is to settle the revolution of PTO. When you push down the button of SET(-) while turn the PTO cruise button on, this lamp turn on.

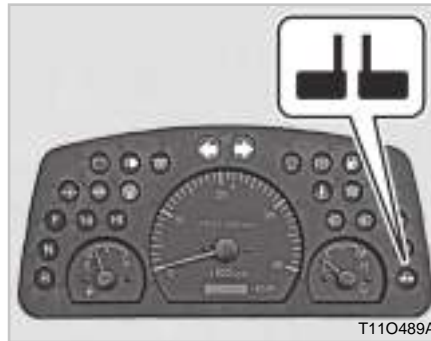
**BRAKe (ONe SIDe) LAmP**

(1) Brake Pedal Lock (Both Sides)

This lamp indicates the operating status of the brake (one side). This comes on when the brake lock for two brake pedals is unlocked.

**⊕ ImPORTANT**

- When driving on a public road or at a high speed, never use only one brake pedal. The tractor can roll over.
- While the brake (one side) lamp is illuminated, the brake pedals are not interlocked and only one brake pedal can be depressed accidentally. make sure to set the pedal lock to the "Lock" position in a normal condition.



## OPERATING The CONTROLS



(1) Hand Throttle Lever  
 (2) Shuttle Shift Lever  
 (3) Clutch Pedal

(4) Steering Column Tilt  
 (5) Brake Pedal (L)  
 (6) Brake Pedal (R)

(7) Main Shift Lever  
 (8) Range Shift Lever  
 (9) Joy-stick Lever

(10) Double Acting Lever  
 (11) PTO Change Lever





**POWeR SHUTTLe**

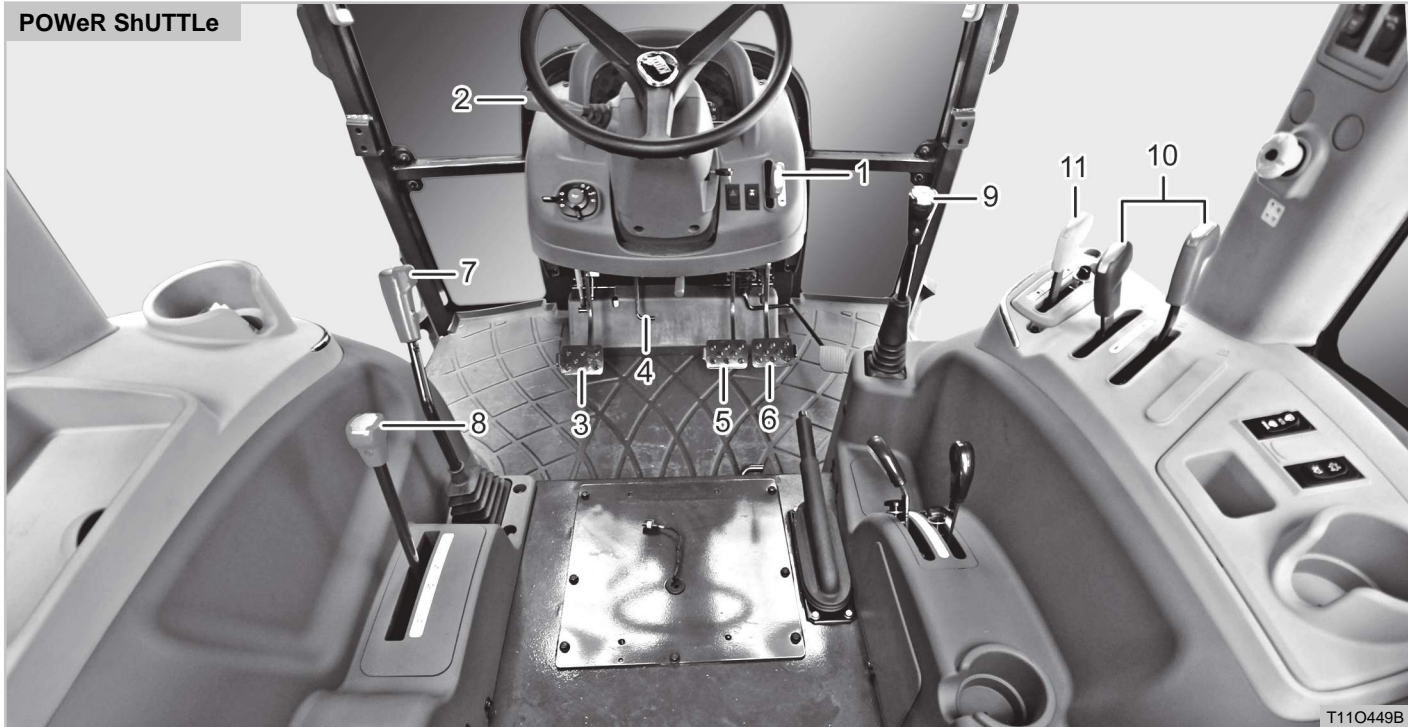

T11O449B

(1) Hand Throttle Lever  
(2) Shuttle Shift Lever  
(3) Clutch Pedal

(4) Steering Column Tilt  
(5) Brake Pedal (L)  
(6) Brake Pedal (R)

(7) Main Shift Lever  
(8) Range Shift Lever  
(9) Joy-stick Lever

(10) Double Acting Lever  
(11) PTO Change Lever



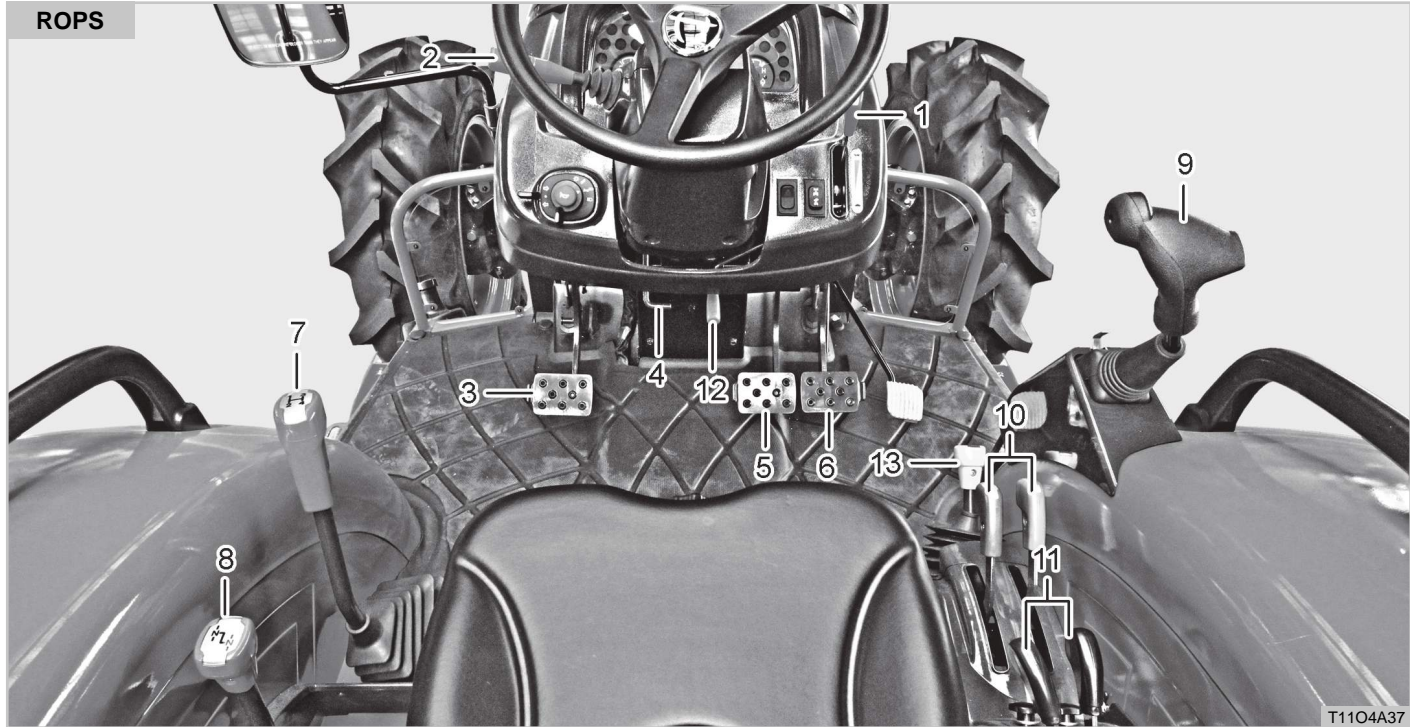

(1) Hand Throttle Lever  
(2) Shuttle Shift Lever  
(3) Clutch Pedal  
(4) Steering Column Tilt

(5) Brake Pedal (L)  
(6) Brake Pedal (R)  
(7) Main Shift Lever  
(8) Range Shift Lever

(9) Joy-stick Lever  
(10) Double Acting Lever  
(11) Position / Draft Control Lever  
(12) Parking Brake Lock Lever

(13) PTO Change Lever

T1104A37



## mAIN SHIFT Lever

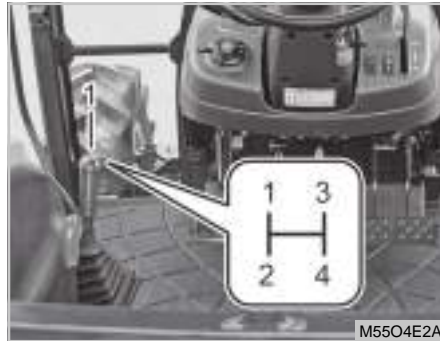

(1) Main Shift Lever

Four speeds can be selected by moving this main shift lever in the 「H」 shaped path. It is possible to shift this lever from the 1st to 4th gears even when the tractor is moving by disengaging the clutch as these gears are synchromeshed. There are 4 speeds for the main shift lever, 3 speeds for the range shift lever and 2 directions for the shuttle shift lever. Therefore, there are 12 forward driving speeds and 12 reverse driving speeds in total.

## RANGE GeAR SHIFT Lever

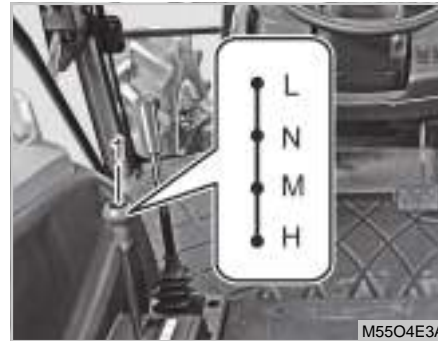

(1) Range Gear Shift Lever (3 Speeds)  
(L) Low Speed      (N) Neutral  
(M) Middle Speed      (H) High Speed

3 speeds can be selected by operating the range gear shift lever in the 「|」 shaped pattern. **Only shift this lever after the tractor is completely stopped by depressing the clutch pedal.** If the lever does not move freely or makes abnormal noise, put the lever in the neutral position, depress the clutch pedal, and then try to shift the lever.

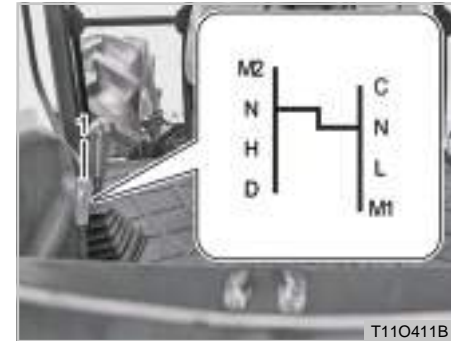

(1) Range Gear Shift Lever (6 Speeds)  
(C) Creep Speed      (L) Low Speed  
(N) Neutral      (M1) Middle Speed 1  
(M2) Middle Speed 2      (H) High Speed  
(D) Drive

6 speeds can be selected by operating the range gear shift lever in the 「H」 shaped pattern. **Only shift this lever after the tractor is completely stopped by depressing the clutch pedal.** If the lever does not move freely or makes abnormal noise, put the lever in the neutral position, depress the clutch pedal, and then try to shift the lever.

### ⚠ CAUTION

- make sure to shift the range gear shift lever with the clutch pedal depressed and the tractor stationary.
- Never put the range gear shift lever in the h gear position during driving backward as it is dangerous to drive at a high speed.
- The tractor is not braked by depressing the brake pedal without depressing the clutch pedal at a low speed as rotational force of the axle has a major effect at a low speed. Therefore, disengage the clutch before depressing the brake pedal to stop the tractor.
- To shift the lever, depress the clutch pedal fully.

## ShUTTLe SHIFT Lever

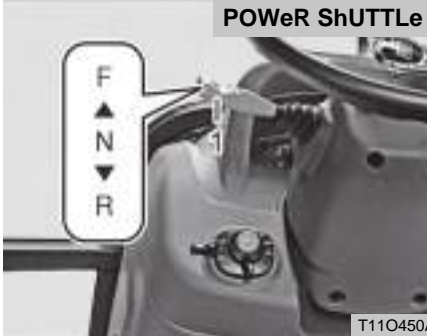

(1) Shuttle Shift Lever  
(F) Forward (R) Reverse (N) Neutral

This lever is to select the forward and reverse driving direction.

Power shuttle model is an electronic hydraulic shift type which can shift without the clutch pedal depressed.

Manual model is a synchronized mesh type, it is necessary to stop the vehicle prior to shifting during driving.

Put this lever into the neutral position when the tractor is not driven. Abrupt operation of the lever can shorten the life of the transmission.

### ⊕ ImPORTANT

- The synchronized shuttle shift lever may be shifted while the tractor is moving slowly and the clutch is depressed, but sudden gear shift changes without clutching may cause transmission damage.





### ► hOW TO USE The SHUTTLe SHIFT LeveR

- To select the driving direction, if the shuttle shift lever is pushed forward with lifting slightly, the tractor is driving forward, and if the shuttle shift lever is pulled backward with lifting slightly, the tractor is driving reverse.
- At initial starting, control the shuttle lever with the engine rpm decreased. When the tractor has started to move, depress the foot throttle pedal to increase the speed.
- If the transmission temperature is low, there may be starting-shock during shifting. Make sure to warm up the engine before driving the tractor.
- Even at the high speed you can shift the shuttle lever without depressing clutch pedal. If the shuttle shift lever is pulled back during forward driving, the tractor is de-

celerated under 5.6 m/h (9 Km/h) and then the driving direction is changed to reverse.

- If the shuttle shift lever is placed in the neutral position from forward or reverse, the tractor is decelerated slowly due to the lose of powers.

#### CAUTION

- **Reduce speed before moving this lever since it is very dangerous to switch the driving direction at a high speed.**

### PTO Shift Lever

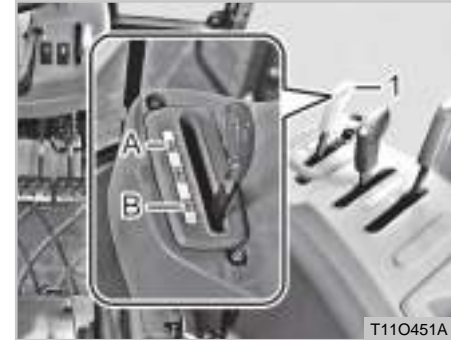

(1) PTO Shift Lever  
(A) 1st

(B) 2nd

This lever is used to shift to one of the 2 PTO speeds as follow:

Shift	1st	2nd
PTO rpm	540	540E

When you work in light load, use 2nd PTO stage.

For high load work, select the 1st gear (540) position and set the engine speed to 2500 RPM to obtain 540 RPM of the PTO speed.

Also, for light load work, select the 2nd gear (540E) position and set the engine speed to 1800 RPM to obtain 540 RPM of the PTO speed.

### ⚠ CAUTION

To prevent injuries:

- When connecting, disconnecting or cleaning any PTO driven equipment, stop all rotating parts, stop the engine and disengage the PTO.

### ⚠ WARNING

- *ensure that implements and attachments are properly installed and that the tractor and implement PTO RPM ratings match.*

## CLUTCh PeDAL



(1) Clutch Pedal

Make sure to depress the clutch pedal to its end. To start off smoothly, put the main and range shift levers into the proper positions and release the clutch pedal slowly.

It is possible to shift the shuttle shift lever without depressing the clutch pedal. However, the clutch pedal should be depressed in advance to cut the power before shifting the main or range shift lever into the desired position. (Power shuttle only)

### ⚠ CAUTION

- When releasing the pedal, remove your foot from the pedal slowly to avoid abruptly driving off.

### ⊕ IMPORTANT

- Never put your foot onto the clutch pedal during driving. The clutch disc can be worn prematurely.
- Be sure to depress the clutch pedal fully when shifting. Otherwise, the shift gear can be broken.



## BRAKE PeDAL

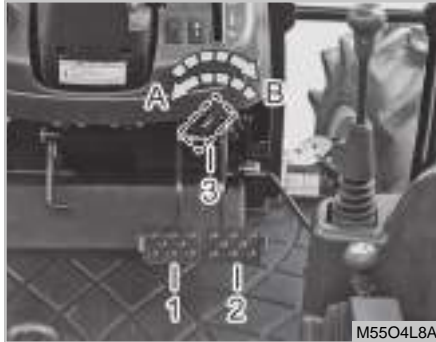

(1) Brake Pedal (L)      (2) Brake Pedal (R)  
 (3) Pedal Interlock  
 (A) Unlock                      (B) Lock

1. Make sure to link the left and right brake pedals as shown in the figure while driving on a road. The tractor can roll over if depressing only one brake pedal at a high speed.
2. To make a sharp turn in a work field, disengage the left and right brake pedals to use one brake pedal. Unlock the brake lock, and then turn the steering wheel while depressing the brake pedal on the turning side.

### ⚠ WARNING

- **make sure to interlock the brake pedals, as an accident such as rollover or impact can occur during driving on the road at high speed.**
- **The durability of the axle can be deteriorated if only one brake pedal is depressed while the 4WD is activated. It is more effective to use the quick turn function, rather than the brake (one side) pedal, while the 4WD is activated and to use the brake (one side) pedal while the quick turn function is activated.**

## STeeRING Whee LADJUSTmeNT



(1) Steering Wheel Tilt Pedal  
 (A) Lowering                      (B) Lifting

The angle of the steering wheel can be adjusted for the driver's comfort. Hold the steering wheel with both hands, depress the tilt pedal lightly and then adjust the position of the steering wheel as desired.

### ⚠ CAUTION

- **Do not adjust the tilt steering while driving. An accident can occur unexpectedly.**

## PARKING BRAKE Lever

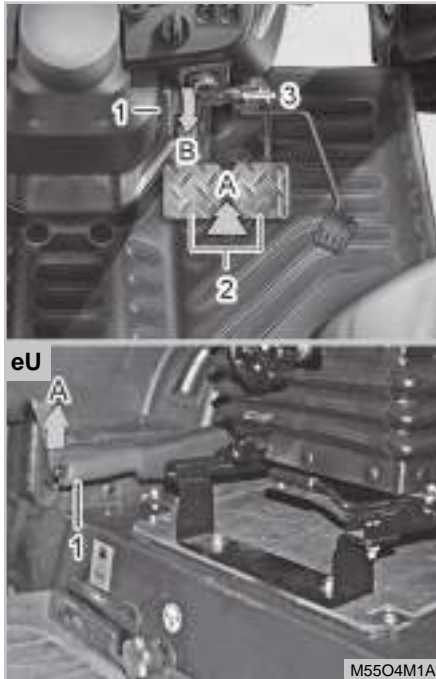

(1) Parking Brake Lever (2) Brake Pedals  
 (3) Pedal Interlock  
 (A) Depressing (B) Pressing Down

To stop the tractor, depress the brake pedal and pull the lever up to apply the parking brake. (USA/AU only)

To stop the tractor, depress the brake pedal and pull the lever up to apply the parking brake. To engage the parking brake, pull the lever up. To release the parking brake, pull up and press the thumb button. Then, while holding the button in, lower the brake lever. (EU only)

### CAUTION

- If the vehicle is driven with the parking brake partially or completely engaged, it may cause early wear of the brake disc.
- If the indicator is ON even with the parking brake released, have the tractor checked by your local KIOTI dealer or workshop immediately.

### WARNING

*To avoid possible injury, death or loss of property from a machine runaway:*

- *With the engine off, the tractor may move unexpectedly regardless of the gear shift position.*
  - *Before leaving the tractor, firmly apply the parking brake to prevent machine runaway.*
- ※ *Only power shuttle model.*

## FOOT ThROTTLe

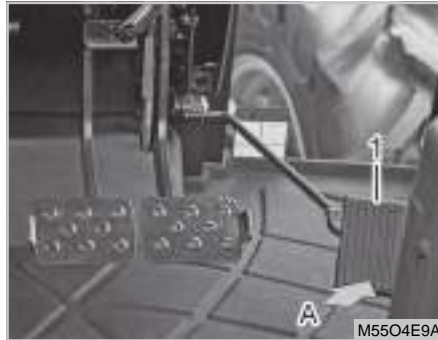





(1) Foot Throttle  
(A) Depress

The foot throttle is mainly used during driving on a road while the hand throttle lever is mainly used in work field.

## hAND ThROTTLe LeveR



(1) Hand Throttle Lever  
 : "Slow"       : "Fast"

The hand throttle lever is to control the engine rpm. The engine accelerates to its full speed by pushing the hand throttle lever (  position) completely out while pulling the lever (  position) decelerates the engine.

The hand throttle lever is mainly used while working in a field.

### CAUTION

- Do not use the hand throttle lever while driving on public highways. Otherwise it can lead to an accident as it becomes hard to decelerate the tractor rapidly.

## DIFFeRENTIAL LOCK PeDAL

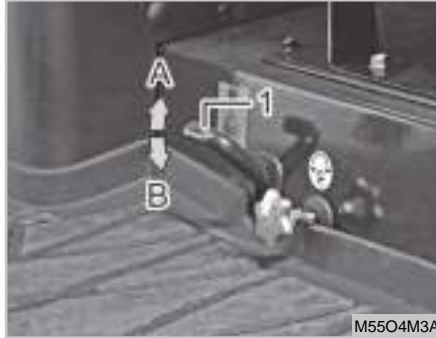

(1) Lock Pedal  
 (A) Release to "DISENGAGE"  
 (B) Depress to "ENGAGE"

The differential lock is to secure the differential system and keep the wheel rotation on both sides the same in order to enhance the traction of the rear axle.

Depressing the pedal engages the differential lock while releasing the pedal disengages the differential lock.

Use this system under the following conditions:

1. When any wheel slips and the tractor does not move in the field.
2. When it is hard to break away from a soft or muddy field.

### ⚠ CAUTION

- **The differential lock should be engaged only while the driving clutch is engaged. If the differential lock pedal does not move when depressing it, try to depress it again after releasing it.**
- **When engaging the differential lock, reduce the engine speed. After engaging it, accelerate the tractor.**
- **make sure to set the steering wheel in the straight ahead position while the differential lock is in use. Otherwise, the differential system can be damaged.**

## SeAT ADJUSTmeNT SeAT SLIDING



(1) Seat Adjustment Lever

To adjust the seat position, pull the lever (1) up under the front of the seat, slide the seat to the desired position, and then release the lever.

Make sure that the seat is firmly fixed by moving it gently after adjustment.

*(1) Seat Adjustment Lever***SeAT BACK ReCLINING***(1) Seat Back Adjustment Lever***SeAT heIghT ADJUSTmeNT***(1) Seat Height Adjustment Handle***⚠ CAUTION**

- **Do not put a hand between the seat and the slides when adjusting the seat position. You can be injured unexpectedly.**

To change the seat back angle, raise the lever (1) on the left of the seat. Then, adjust the seat back angle with the lever pulled. Release the lever after adjustment. Make sure that the lever is returned and the seat is firmly fixed after adjustment.

The seat height can be adjusted to fit to the driver. Turning the handle (1) on the front of the seat clockwise raises the seat while turning it counterclockwise lowers the seat.

### CUSHION STRENGTH ADJUSTMENT



(1) Cushion Adjustment Lever

The seat cushion can be adjusted according to the weight of the driver. Turning the cushion adjustment lever (1) on the front of the seat to the (-) direction makes the cushion softer while turning it to the (+) direction makes the cushion firmer.



(1) Cushion Adjustment Lever

### SeAT BeLT



(1) Seat Belt  
(A) Release

(2) Release Button

The seat belt is semi-automatic self-retracting type. Make sure to fasten the seat belt before driving. To disengage the seat belt, press its red release button.



## POSITION CONTROL Lever

### **⚠ WARNING**

- **make sure that the seat belt is not twisted. It cannot work properly, leading to a hazardous condition.**
- **The seat belt should go around your body as low as possible, not your waist or abdomen. Otherwise, the seat belt cannot protect you properly.**

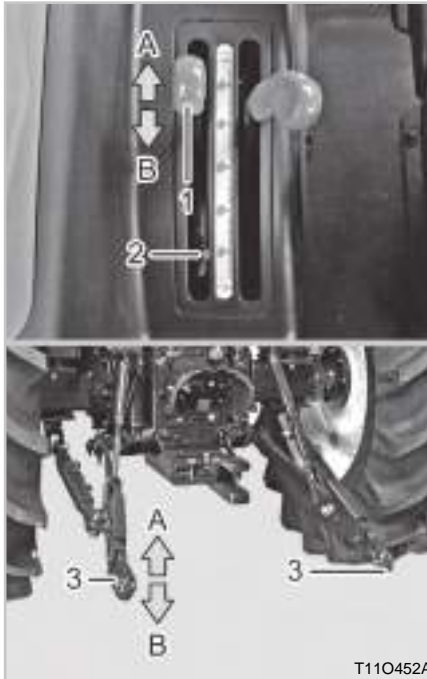

- (1) Position Control Lever      (2) Lock Bolt  
 (3) Lower Link  
 (A) Lifting                              (B) Lowering

The position control lever is used to adjust the height of implements on

the 3-point hitch ends.

The implement attached to the lifting arm can be lowered by pushing the lever while the implement is raised by pulling the lever.

In order to limit the lowering height of implements, use the lock bolt (2) to limit the operating range of the lever.

For detailed information, refer to "3 point hitch control" in Chapter 5.

## DRAFT CONTROL LeveR

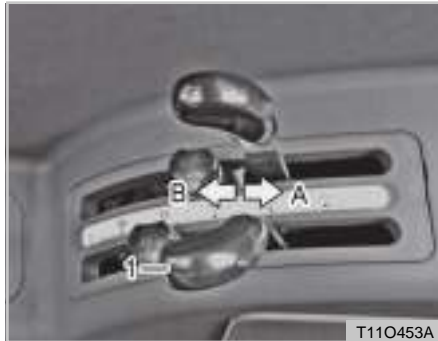

T11O453A

(1) Draft Control Lever

(A) Lifting

(B) Lowering

The draft function can be used for the plow which is installed to the lower link (lifting arm).

If the plow is operated with excessive draft, the lifting arm is automatically raised to reduce the draft and then returned to its original. This is called; "Draft Function". The plowing depth can be controlled by the soil status by putting the draft control lever into the "Deep" position to activate the draft function at mid load and putting

the lever into the "Shallow" position to activate the draft function at light load.

For detailed information, refer to "Draft control" in Chapter 5.

## JOYSTICK LeveR



M55O4S4A

(1) Joystick Lever

This joystick lever is used mainly to operate the front end loader when attached to the tractor.

For detailed information, refer to "Handling Loader" in Chapter 6.

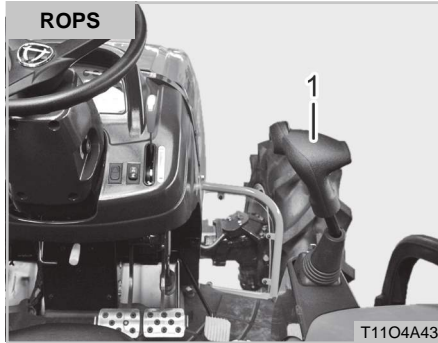

(1) Joystick Lever

### LIFTING ARM (LOWeR LINK) SPeED CONTROL KNOB



(1) Lowering Speed Control Knob  
(A) High Speed (B) Low Speed

Turning the knob counterclockwise increases the lowering speed while turning it clockwise decreases the lowering speed. Also, turning it clockwise to its end can fix the implement to a certain position.

#### NOTE

- This knob does not control the lifting speed of the lower link.

### DOUBLE ACTING LeVeR

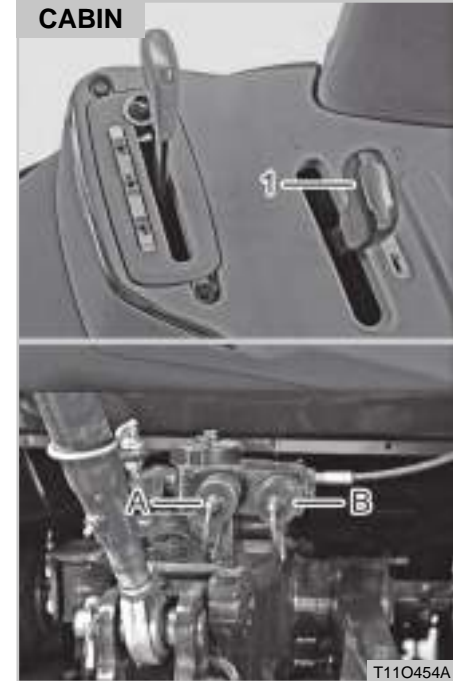

(1) Double Acting Valve 1 & Lever 1  
(A) Port A (B) Port B

This lever is used to control a auxiliary hydraulic implement installed on rear.

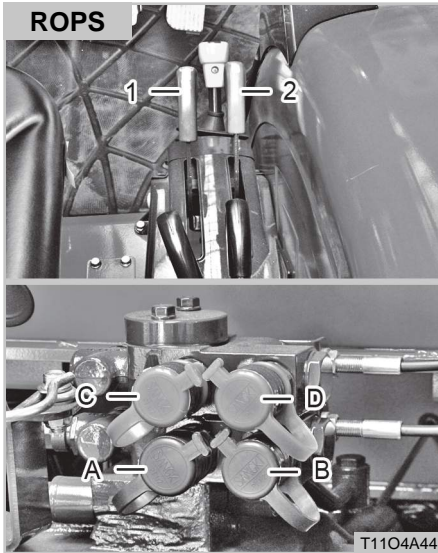

- (1) Double Acting Valve 1 & Lever 1
- (2) Double Acting Valve 2 & Lever 2
- (A) Port A                      (B) Port B
- (C) Port C                      (D) Port D

Pushing the lever supplies the port A with hydraulic pressure while pulling it supplies the port B with hydraulic pressure.

For detailed information, see "Operation" in Chapter 5.

**⚠ WARNING**

- *Put the detent valve(if equipped) operating lever into the neutral position when the hydraulic implement is not in use. If the detent valve is kept in the operating position for an extended period of time, the relief valve is kept open and the temperature of the hydraulic fluid rises, leading to damage of various hydraulic parts, such as the oil seals and O-rings.*



# CABIN SYSTEM INTERIOR DevICeS



(1) Speaker  
(2) Air Grill

(3) Air Inlet  
(4) Heater/Air Conditioner Switch

(5) Room Lamp  
(6) Air Intake Gill Lever

(7) Room Mirror (If equipped)  
(8) Sun Visor (If equipped)



AU

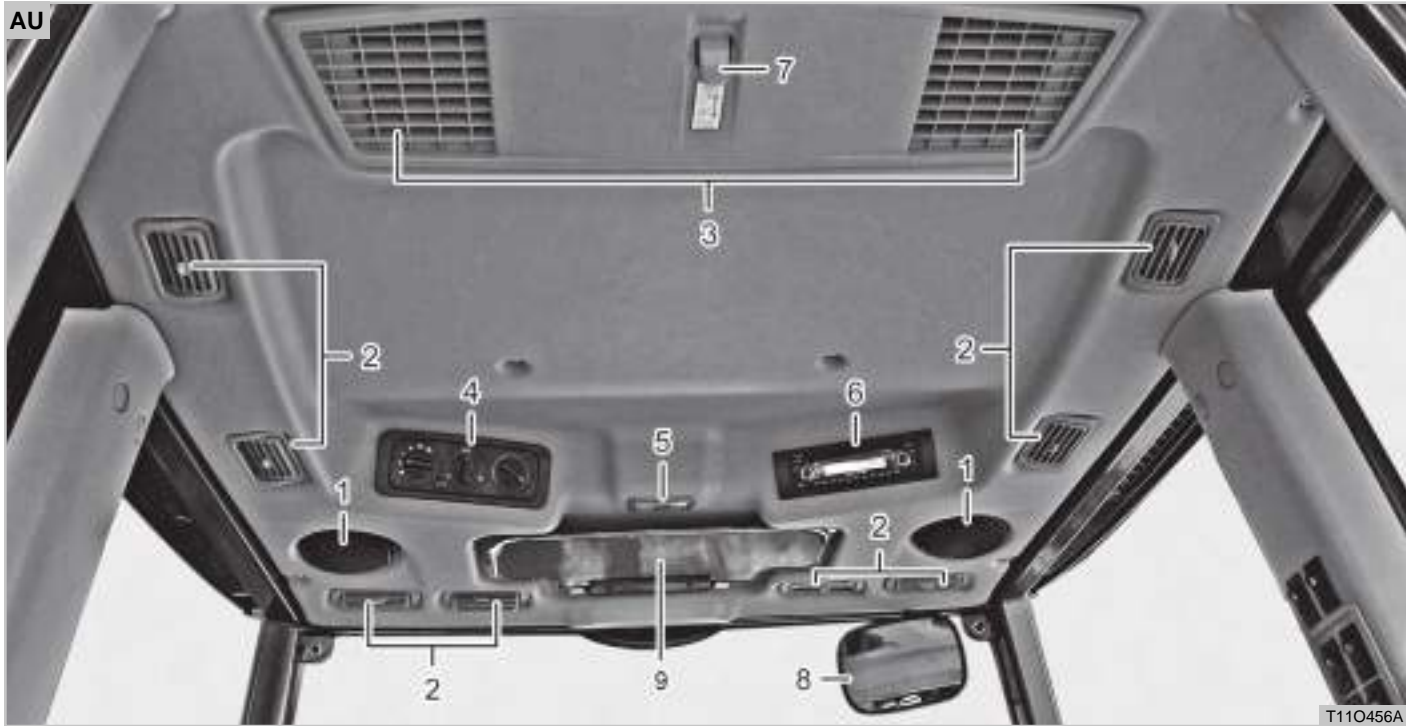

T11O456A

(1) Speaker  
(2) Air Grill

(3) Air Inlet  
(4) Heater/Air Conditioner Switch

(5) Room Lamp  
(6) CD Player

(7) Air Intake Gill Lever  
(8) Room Mirror (If equipped)  
(9) Sun Visor (If equipped)





## eXTeRIOR DevICeS



- (1) Work Lamp      (2) Antenna  
 (3) Wiper          (4) Outside Rearview Mirror  
 (5) Door Handle    (6) Turn Signal Lamp

1. The cabin is designed optimally for the driver's comfort and convenience.
2. This tractor has wide windows as well as outside rearview mirrors on both sides to provide a clear and wide rear view.
3. The cabin can be kept comfortable and pleasant by operating the air conditioner and heater.

4. The cabin structure is safe as it is verified by the **ROPS** (Roll Over Protection Structure) test and **FOPS** (Falling Object Protection Structure) . However, make sure to fasten the seat belt for the best protection.

## eNTRANCe



- (1) Door Lock      (2) Door Handle

Pulling the handle forward can open the door.

The door can be locked through the lock on the outside of the door with the ignition key.

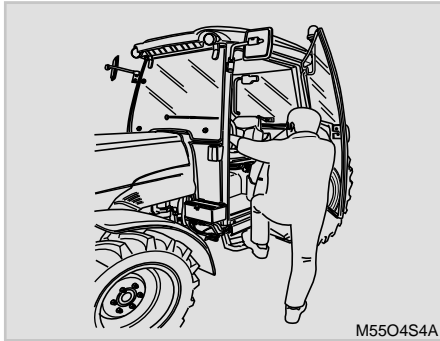

Enter or leave the tractor through the left-hand door.

**⚠ WARNING**

- *Do not jump on or off the tractor. It may cause injuries. Always face the tractor, use the hand rails and steps, and get on or off slowly. maintain a minimum three point contact to avoid falling (both hands on rails and one foot on the step, or one hand on the hand rail and both feet on the steps).*

**ReAR WINDOW**



(1) Handle of rear window (2) Button

Press the button on the rear window handle lightly to open the rear window in the cabin. To close it, hold the handle and pull it gently.

**⚠ WARNING**

- *The rear window may not be opened due to an implement. make sure to check if there is enough space to open the window to prevent damage and breakage by an implement.*
- *Never drive the tractor with the door open. An accident can occur.*

**SiDe WINDOW**



(1) Side Window

Do not leave the doors fully open while driving the tractor. Side windows can be partially open to vent the cab.





## WORKING LIGHT



- (1) Working Light Switch (Front)  
(2) Working Light Switch (Rear)

The working lights are installed to the front and rear sections of the roof, and their operating buttons are installed in the right panel in the cabin.

To turn on, position the switch marked (front) to the "ON" position.

The key switch should be positioned to the "ON" position to power the working lights.

### ⚠ WARNING

- *Do not drive the tractor on a road with the work lights "ON" at night.*
- *The approaching or following vehicle's visibility can be disturbed, which is very dangerous for both drivers. In this case, use the hazard lamps.*

## WIPeR



- (1) Wiper Operating Switch (Front)  
(2) Wiper Operating Switch (Rear)

1. To turn on, position the switch marked (wiper) to the "ON" position.
2. The washer fluid is sprayed through the nozzle of the wiper by pressing the switch again with the key switch in the "ACC" or "ON" position.



M55O4N4A

(1) Washer Fluid Tank

3. The washer fluid tank for cleaning the windows is installed behind the license plate bracket on the rear left side outside the cabin. Check the washer fluid level and top off the tank if necessary.

### ⚠ WARNING

- *Normal water can be used as the washer fluid, but it is recommended to use the washer fluid made exclusively for vehicles. especially, make sure to use seasonal washer fluid in winter.*
- *The washer fluid motor can be damaged if you are trying to spray the washer fluid when its tank is empty. Therefore, make sure to check the fluid level before driving.*
- *Spray enough washer fluid and operate the wiper if there is dirt on the window. When operating the wiper while it is frozen to the window, its fuse can be blown. In this case, operate the wiper after increasing the cabin temperature enough to defrost the wiper.*
- *Wiper blade can be damaged if operating on a window that is iced over.*

### RADIO CASSEtTe/CD PLAYeR (IF eQUIPPeD)



(1) CD Player

Pushing the PWR switch one time makes the power ON, and pushing the PWR switch one more time again makes the power OFF.

### ⚠ CAUTION

- **If the volume of the audio system is too high, the driver can be distracted, resulting in an accident.**

**INSerTING CD/CASSeTTe TAPE**

Inserting a CD/cassette tape operates the CD/cassette player automatically. For detailed information, refer to the owner's manual for the audio system.

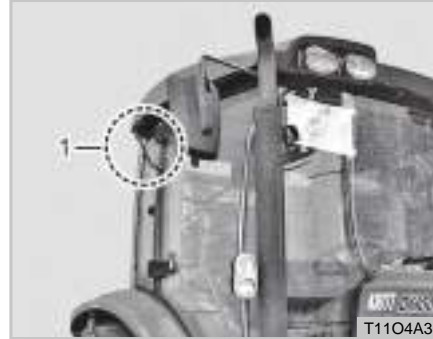
**ANTeNNA  
RADIO ANTeNNA**

(1) Antenna

Check the contact and angle of the antenna in case of poor signal reception.

**CABIN LAmP**

(1) Cabin Lamp

If you press the lens, the cabin lamp will be turned on. If you press it again, it will be turned off.

**! CAUTION**

- **The cabin lamp can be operated without the key inserted. however, turning it on for an extended period of time can discharge the battery.**

### ACCeSSORY ROOm mIRROr (IF eQUIPPeD)



(1) Room Mirror

The cabin is equipped with the room mirror for the driver's convenience. Adjust the angle of the mirror before driving for a clear rear view.

### CIGAReTTe LIghTeR



(1) Cigarette Lighter

Press and release the cigarette lighter. When it is heated to the specified level, it pops out automatically. Then, it is ready to be used. It can also be used as a power source. It is operable only when the ignition switch is in the "ON" position.

### CUP hOLDeR AND StORAgE



(1) Cup Holder

(2) Storage

There are cup holders and storage sections for keeping cups and manuals for convenience.

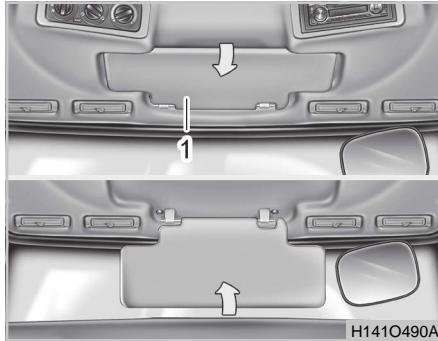
**SUN VISOR (IF eQUIPPeD)**

(1) Sun Visor

Pull it down to block the sunlight from the front. Keep it folded unless necessary.

**ReCIRCULATION/FReSh AIR mODE**(1) Air Vent  
(A) Fresh Air(2) Vent Lever  
(B) Recirculation

It is possible to recirculate internal air or draw fresh air when the air conditioner is in operation.

Pushing the vent lever to "A" opens the vents and draws fresh air from outside. Pushing the vent lever to "B" closes the vents to recirculate the air in the cabin.

**⚠ WARNING**

- *This cabin is not designed for spraying chemicals and cannot block polluted outside air from entering.*

## heATeR AND AIR CONDITIoNeR

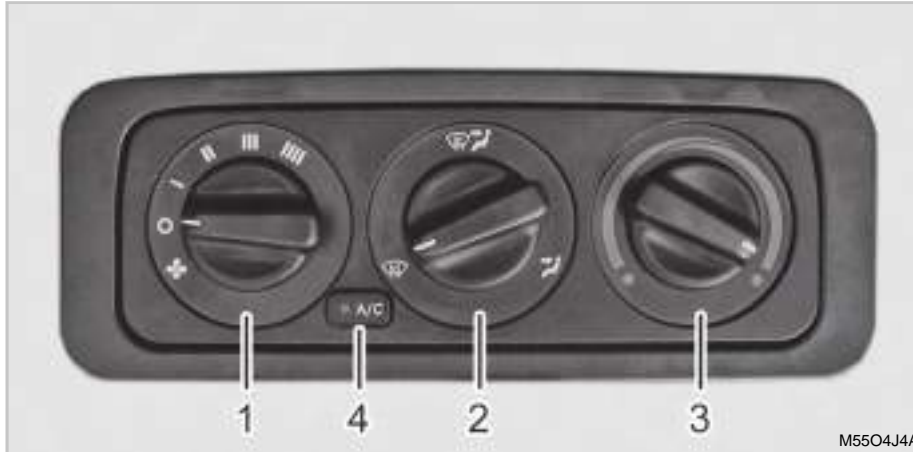

(1) Fan Speed Control Dial  
(3) Temperature Control Dial

(2) Vent Mode Control Dial  
(4) Air Conditioner Switch

The air conditioner should be operated with the engine running.

### ⚠ WARNING

- **Do not leave a child alone in the cabin. his/her health can be threatened as internal temperature rises rapidly in hot weather or on a sunny day.**
- **Use the fresh air mode in normal conditions and use the air recirculation mode only if necessary. Continued operation of the air recirculation mode can cause the inside to become stuffy, causing headaches, drowsiness, or frost on the windows. Do not operate the recirculation mode for an extended period of time.**

## FAN SPeED CONTROL DIAL

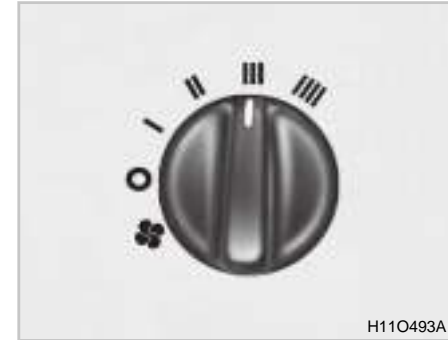







The fan speed for the heater and air conditioner can be adjusted in four positions.

**AIR CONDITIONER SWITCH**

Press it to activate the air conditioner and press it again to deactivate the air conditioner.

The heater can be operated by the temperature control switch and fan speed control switch.

**VENT MODE CONTROL DIAL**

- : When the vent mode control dial is turned to the (  ) position, air comes out from the 4 vents on the left and right.
- : When the dial is turned to the Bi-level (  ) position, air comes out from 4 vents in the front and 4 vents on the left and right.
- : When the dial is turned to the Defrost (  ) position, air comes out from 4 vents in the front to defrost the windshield.

**TEMPERATURE CONTROL SWITCH**

The desired temperature can be set by adjusting this dial. Warm air flows out by turning it clockwise (Red), and cool air flows out by turning it counterclockwise. (Blue)

The temperature control dial only controls the amount of air flowing through the heater and air conditioner.

**Therefore, unnecessary load can be applied to the air conditioner if this dial is set to the high temperature with the A/C in operation.**

**CAUTION**

- After parking the tractor under direct sunlight for an extended period of time, open all the windows to remove hot air in the cabin and operate the A/C.
- Keep the windows closed while the A/C is in operation for effective operation.
- Turn off the air conditioner for better engine power when the work load rapidly increases.
- When the tractor is stationary and being used in high load work, reduce the A/C operation period as the engine may be overheated.
- If cold air does not come out from the vents during long hours of driving, turn off the air conditioner, set the fan speed control dial to the 4th speed, drive for 5 to 10 minutes, and then turn on the air conditioner.

**CAUTION**

- make sure you operate the air conditioner once or twice a month in winter season to prevent refrigerant leakage and facilitate the compressor lubrication for durability of the A/C components.

**A/C ReFRIGeRANT AmOUNT IN-SPeCTION**

Insufficient refrigerant can lead to poor performance of the air conditioner. Also, excessive refrigerant can affect the A/C components. If any malfunction is found, have the system checked by your Dealer.

**A/C ReFRIGeRANT CAPACITY**

Type	Capacity
HFC-134a	1.65 lbs. (0.75 kg)



**⚠ WARNING**

- *As the A/C refrigerant is under high pressure, have the A/C serviced only by a qualified service personnel. Otherwise, injuries can occur.*
- *If you sleep with the air conditioner or heater in operation, you may be suffocated to death.*
- *If keeping the A/C on for an extended period of time, inside air can become impure. Therefore, draw outside air and ventilate the cabin regularly.*

**⚠ CAUTION**

- Keep the windows closed while the A/C is in operation for effective operation.
- Turn off the air conditioner for better engine power when the work load rapidly increases.
- When the tractor is stationary and being used in high load work, reduce the A/C operation period as the engine may be overheated.
- make sure you operate the air conditioner once or twice a month in winter season to prevent refrigerant leakage and facilitate the compressor lubrication for durability of the A/C components.
- If the tractor has been parked under strong sunlight for a long period of time, open the windows to ventilate the cabin before operating the A/C.

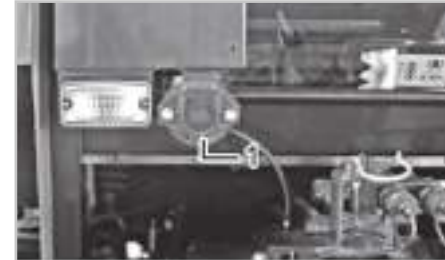
**7-PIN POWER OUTPUT SOCKeT**

AU/eU

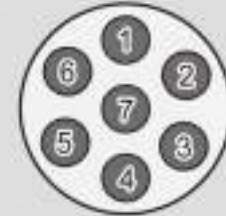

USA

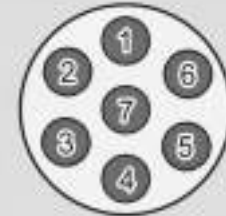

M55O4N9A

(1) Power Connector

The 7-pin socket is installed on the rear left side of the tractor.

This supplies power to the brake lamps, turn signal lamps, and position lamps of the trailer.

► USA/AU

NO.	CIRCUIT	COLOR OF WIRE
1	Earth	White
2	Spare	Black
3	Left turn signal	Yellow
4	Stop	Red
5	Right turn signal	Green
6	Tail	Brown
7	Spare	Blue

► eU

NO.	CIRCUIT	COLOR OF WIRE
1	Left turn signal	Yellow
2	Spare	Blue
3	Earth	White
4	Right turn signal	Green
5	Right illumination	Brown
6	Stop	Red
7	Left illumination	Black

**⚠ WARNING**

- **When driving on a road with an implement which has exterior lamps, such as a trailer, make sure to turn on those lamps by connecting them to the 7-pin socket in order to prevent an accident.**
- **make sure you check for proper operation after connecting the 7-pin socket to the trailer. It may not operate depending on the trailer specifications. Consult your local KIOTI Dealer for this issue.**

**TIREs, WheelS AND BALLAST**

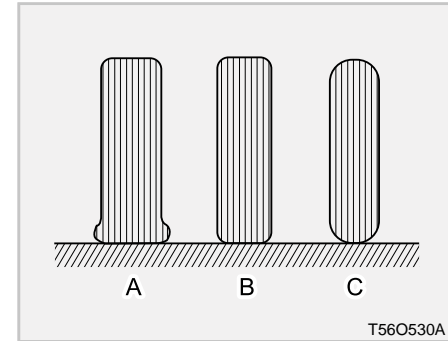

(A) Insufficient  
(B) Standard  
(C) Excessive

Though the tire pressure is factory-set to the proper tire inflation, it naturally drops slowly in the course of time. Thus, check it everyday and inflate as necessary.

**⚠ WARNING**

- **Do not use tires larger or smaller than specified.**
- **Do not disassemble or assemble the tire. If it is necessary to disassemble/assemble the tire, let a qualified service person perform the work.**

## INFLATION PRESSURE

Always maintain the proper tire inflation pressure. Make sure the tire pressure does not exceed the pressure recommended in the manual.

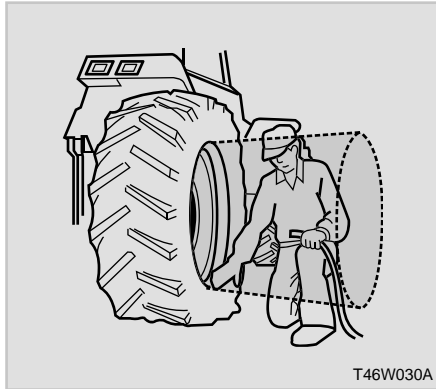

T46W030A

### ⚠ WARNING

- **The tire rims can fall out of the tires. Causing the tire bead edge to blow out. Therefore, stay out of their way when checking or inflating tires.**

Class	Tire Sizes	Inflation Pressure
Front	9.5-20/8PR:USA 11.2x20/8PR:AU/EU	34.1psi (2.4kg/cm <sup>2</sup> )
Rear	14.9-28/8PR: USA 14.9x30/8PR: AU/EU	25.6psi (1.8kg/cm <sup>2</sup> )

※ This pressure is based on agriculture tire.

### 📖 NOTE

- Keep the front tire pressure to maximum when using the front end loader or front suitcase weights.
- If tires with a different size from the ones already in use are installed, contact the **KIOTI** dealer for the front/rear wheel speed ratio. Improper front/rear wheel speed ratio can result in excessive wear of the tires.

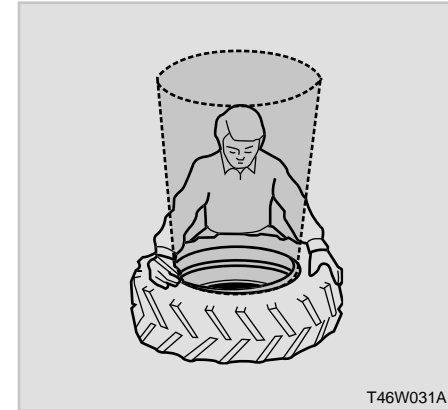

T46W031A

### ⚠ WARNING

- **Do not weld or apply heat to the tire rim or disc. The tire can explode due to the rapidly increased pressure in the tire.**
- **Check tires for inflation pressure, damage, deformation, and excessive wear on lug and damage of rim and disc. Also check if wheel bolts, rim bolts, and nuts are loose.**

## TReAD

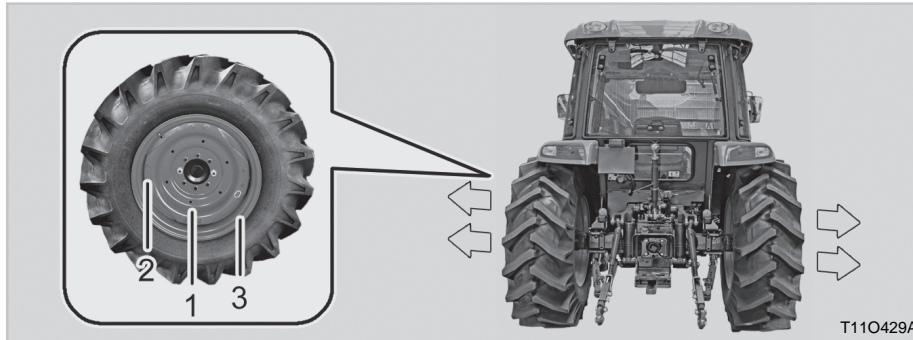

(1) Disc

(2) Rim Bolt

(3) Rim

The rear axle tread width is adjustable by changing the installation of the tire (together with rim) to the disk, to suit the type or condition of work.

### **⚠ WARNING**

*Never operate tractor with a loose rim, wheel, or axle.*

- *Always tighten nuts or bolts to the specified torque.*
- *make sure to frequently check that all these parts are firmly tightened.*
- *make sure to perform inspection daily.*



FRONT/ReAR TIRE TReAD [RX6020(C/C-P)]

in. (mm)

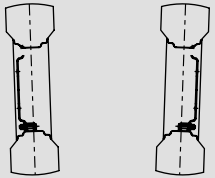
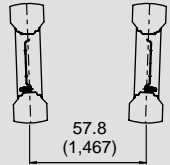
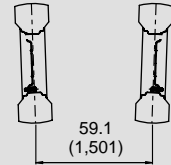
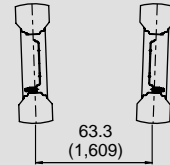
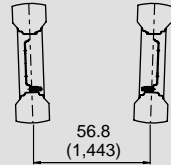
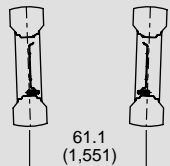
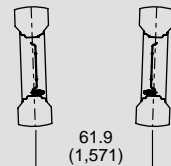
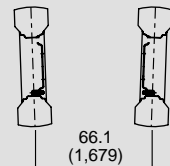
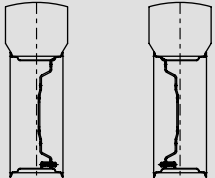
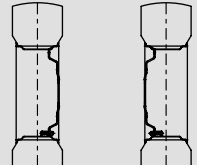
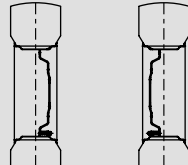
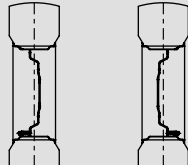
	Standard	Be adjusted			
Front	 <p>54.1 (1,373)</p>	 <p>57.8 (1,467)</p>	 <p>59.1 (1,501)</p>	 <p>63.3 (1,609)</p>	 <p>56.8 (1,443)</p>
		 <p>61.1 (1,551)</p>	 <p>61.9 (1,571)</p>	 <p>66.1 (1,679)</p>	
Rear	 <p>54.1 (1,374)</p>	 <p>65.6 (1,666)</p>	 <p>61.1 (1,554)</p>	 <p>56.1 (1,424)</p>	

4

T110461A



**FRONT/ReAR TIRE TReAD [RX6620(C/C-P)]**

in. (mm)

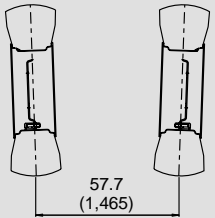
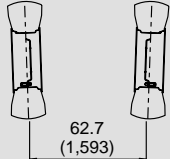
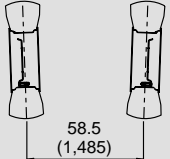
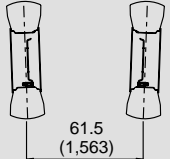
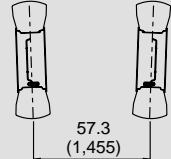
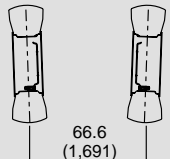
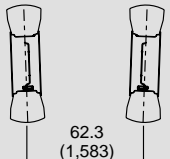
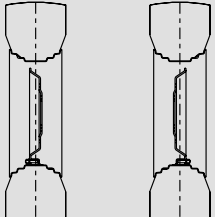
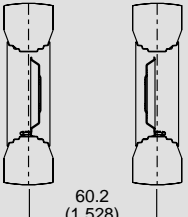
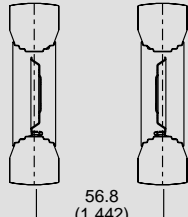
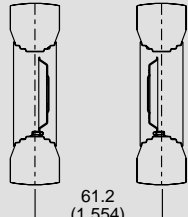
	Standard	Be adjusted			
Front	 <p>57.7 (1,465)</p>	 <p>62.7 (1,593)</p>	 <p>58.5 (1,485)</p>	 <p>61.5 (1,563)</p>	 <p>57.3 (1,455)</p>
		 <p>66.6 (1,691)</p>	 <p>62.3 (1,583)</p>		
Rear	 <p>55.7 (1,416)</p>	 <p>60.2 (1,528)</p>	 <p>56.8 (1,442)</p>	 <p>61.2 (1,554)</p>	

T110462A



FRONT/ReAR TIRE TReAD [RX7320(C/C-P)]

in. (mm)

	Standard	Be adjusted			
Front	<p>58.1 (1,476)</p>	<p>66.0 (1,676)</p>	<p>62.0 (1,576)</p>	<p>57.7 (1,466)</p>	<p>65.6 (1,666)</p>
Rear	<p>59.6 (1,515)</p>	<p>63.5 (1,613)</p>	<p>67.4 (1,713)</p>	<p>71.3 (1,811)</p>	

T110463A

**Wheel TORQUE AND DIREcTION**  
**FRONT/Rear Wheel INSTALLATION PATTeRN**

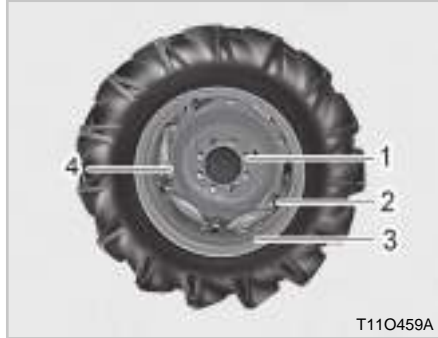

- (1) Wheel Nut / Bolt
- (2) Rim Bolt
- (3) Rim
- (4) Disc

The front and rear axle tread width are adjustable by changing the installation of the tire (together with rim) to the disk, to suit the type or condition of work. Ref to "TREAD" in prior page.

**FRONT AND Rear Wheel BOLT AND NUT TORQUE**

Tightening torque of wheel bolt and nut	Front	196.1~225.6 N·m 20~23 kgf·m 144.7~166.3 lb·ft
	Rear	274.6~318.7 N·m 28~32.5 kgf·m 202.5~235.1 lb·ft

**Rim BOLT AND NUT TORQUE**

Tightening torque of rim bolt and nut	Front & Rear	259.9~304 N·m 26.5~31 kgf·m 191.7~224.2 lb·ft
---------------------------------------	--------------	---

**⚠ WARNING**

- **Use tires approved by KIOTI only.**
- **Assemble the tire as shown in the figure.**
- **Contact your local KIOTI Dealer if it is necessary to change the tire specification or installation method.**



**Wheel INSTALLATION DIREction**

For agricultural tires, make sure to install them with their arrow marks on their side pointing to the front driving direction.

The tire is correctly installed if the tread mark "V" on the ground is shown correctly, not up side down, while the tractor is moving forward.

**ADDITIONAL WeighT  
ADDITIONAL FRONT WeighT**

(1) Additional Front Weight

If the front tires are excessively loaded and it becomes hard to steer the tractor, the tires can be worn faster and the durability of the front axle can be deteriorated.

If the loader is not installed, attach a weight to the front frame of the tractor as a safety measure.

If a heavy implement is installed at the rear or when towing a heavy trailer, the front wheels may be lifted. Add sufficient weight to keep steerability and to prevent rollover.

If sufficient weight, such as front loader, is applied to the front wheels, remove the extra front weight.

## COMPONENTS FOR ADDITIONAL FRONT WEIGHT

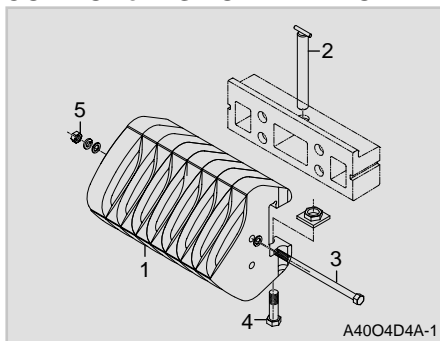

- (1) Front-end Weight  
 (2) Retaining Pin  
 (3) Front Weight Mounting Bolt  
 (4) Front Weight Bolt  
 (5) Nut

When installing or removing a weight, always check the tire inflation pressure and adjust it as necessary.

The front weights are available at the **KIOTI** Dealer. For required number of weights, consult your local **KIOTI** Dealer.

## max. load

27 kg x 10 Pieces (595 lbs)

## CAUTION

- Additional weight might be needed for transporting heavy implements.
- Reduce the speed regardless of additional weight when driving on a bumpy or rough road with the implement lifted. The tractor can roll over.

## ImPORTANT

- Attach only the required amount of weight. Otherwise, the life of the axle or wheel can be shortened.

## ADDITIONAL REAR WEIGHT (IF EQUIPPED)

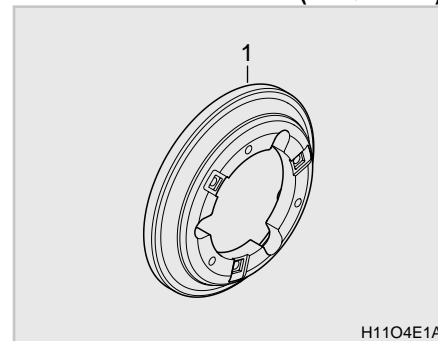

- (1) Rear Weight

The rear weight is used to maximize the traction of the tractor by increasing the grip of the rear wheels when using a heavy trailer or plow.

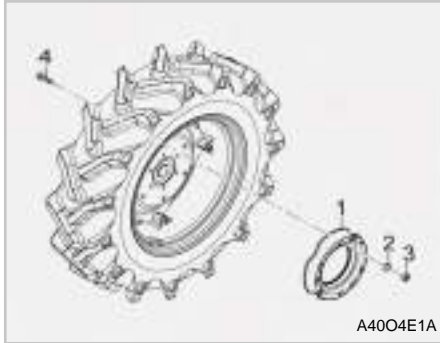

(1) Rear Weight (3) Nut  
(2) Spring Washer (4) Bolt

For detailed information on installation, contact your local **KIOTI** Dealer.

#### max. load

30 kg×2 Pieces (132 lbs)

#### ⊕ IMPORTANT

- **Attach only the required amount of weight.**
- **Unnecessary weight can result in poor braking performance, rapid wear of the brake discs, shortened axle life, and increase in fuel consumption.**

#### ADDITIONAL LIQUID TYPE WeighT

It is possible to inject water and calcium solution into the tire to use it as a ballast.

#### 📖 NOTE

- The liquid injection should be performed only by a qualified service personnel.  
For detailed information, contact your local **KIOTI** Dealer.

If one liter of water is mixed with 0.4 kg of calcium, this liquid does not freeze down at -49 °F (-45 °C).

For a tire without a tube, fill it with water and calcium solution at least to the valve stem level (75%).

If the tire without a tube is not filled with water and calcium solution sufficiently, a part of the rim is exposed, resulting in corrosion.

For a tire with a tube, fill it up to 90% of its level.

#### 📖 NOTE

- If the liquid ballast is used, inflate the tire 0.14bar (2psi) more than the specified pressure. This is to compensate for the ventilation symptom which occurs while the tire is moving.

### mASS(eS) AND TIRe(S)

Ref to the following information for the determination of the total mass, the axle loads, the tire load carrying capacity.

var.	Axle No.	Tire sizes		Load Capacity (kg)	Technically permissible maximum mass per axle (kg)	Distribution of this(these) mass(es) among the axles (%)	maximum permissible vertical load on the coupling point (daN)
AAH ABM	Front wheel	Agri	11 2-20, 8PR	1,120	2,100	42	750
			320/70 R20	1,150	2,100	42	
		Agn	300/70 R20	1,215	2,100	42	
		Turf	31x13 5x15,8PR	1,180	2,100	42	
		Ind	12.5/80-18,10PR	2,135	2,100	42	
	Rear wheel	Agri	14 9-30, 8PR	1,930	2,900	58	
			420/70 R28	2,070	2,900	58	
		Agn	420/70 R30	2,120	2,900	58	
		Turf	44x18x20,4PR	1,550	2,900	58	
		Ind	18.4-24,8PR	2,900	2,900	58	



# OPeRATION

**PRe-OPeRATION CheCK ..... 5-2**

**OPeRATING The eNGINe ..... 5-3**

    STARTING THE ENGINE .....5-3

    CHECKING WARNING LAMPS .....5-7

    STOPPING THE ENGINE .....5-7

    WARMING UP .....5-8

    JUMP STARTING .....5-10

**OPeRATING The TRACTOR ..... 5-11**

    HOW TO DRIVE .....5-11

    PARKING .....5-14

    TURNING .....5-16

    DRIVING ON SLOPES .....5-16

    PRECAUTIONS WHEN COMING IN AND OUT OF WORK FIELD...5-17

    PRECAUTIONS WHILE DRIVING ON THE ROAD .....5-17

    LOADING AND UNLOADING .....5-18

    PRECAUTIONS WHEN USING POWER STEERING .....5-19

    3-POINT HITCH CONTROL SYSTEM .....5-21

    REMOTE HYDRAULICS .....5-24

    CONNECTING AND DISCONNECTING IMPLEMENT .....5-27

# 5

## PRE-OPERATION CHECK

It is a good practice to know the condition of your tractor before you start it. You should do a routine check before each use.

### CAUTION

- **Park the tractor on the level ground, stop the engine, and apply the parking brake before checking or repairing it. Refer to "DAILY CHECKING ITEMS" in the section 7 "MAINTENANCE" for pre-operation check.**
- **Be sure to read and understand the information titled as "DANGER", "WARNING", and "CAUTION" thoroughly for safe operation.**

### VISUAL CHECK ITEMS

- Walk around inspection to look for loose or missing hardware.
- Engine oil level.
- Transmission oil level.
- Coolant level.
- Clean the front grill and radiator screen.
- Inspect air cleaner element.
- Brake pedal free play.

### INSPECT ALL FOR PROPER OPERATION

- All dash gauges and indicators.
- Head lights, tail lights, and working lights.
- Accessible wiring harness for any damage.
- Seat belt and cabin for damage.
- All "DANGER" and "WARNING" decals.
- Fuel level.
- Tire pressure and wheel bolt tightness condition.
- 3-point hitch and securing pins.

For detailed information, refer to "Maintenance schedule chart" in chapter 7.

### INITIAL OPERATION

Driving a new tractor at a high speed or under heavy load can affect its durability.

Make sure to run the tractor at the proper work load and speed for the initial operation of 10 to 20 hours.

### TIPS FOR BREAKING-IN

1. Start the engine and idle the engine at a low speed for 3 to 4 minutes in advance.
2. Increase the idling time in cold weather.
3. Do not drive the tractor at the maximum speed on a road.
4. Never apply excessive load during work.
5. Idle the engine at a low speed for 2 to 3 minutes before stopping it.



## OPERATING The eNGINE

### STARTING The eNGINE

#### WARNING

*To avoid accidents:*

- *Be sure to read and understand the warning and caution decals on the tractor thoroughly.*
- *Run the engine only in a well-ventilated area, or you can be suffocated by exhaust gas.*
- *Never start the engine unless you are on the driver's seat.*
- *The tractor can abruptly start off, resulting in an injury or accident.*

#### IMPORTANT

- **Use of a starting aid can cause serious damage and will not be covered under warranty**
- **Never try to start the engine for over 10 seconds consecutively to protect the start motor and battery from damage.**

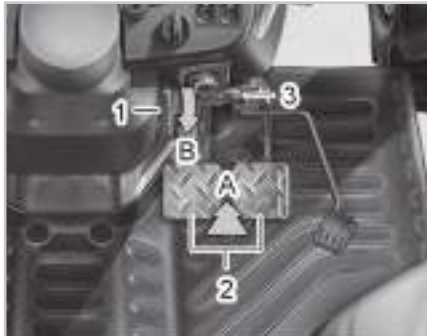

(1) Parking Brake Lever (2) Brake Pedals  
(3) Pedal Interlock  
(A) Depressing (B) Pressing Down

1. Make sure there is no obstacle around the tractor.

2. Make sure the parking brake is set.

#### IMPORTANT

- **make sure that the brake pedals are fully depressed before pulling the parking brake lever up. (For eU)**

#### NOTE

- When the parking brake is engaged, the parking brake lamp on the instrument cluster illuminates. When releasing it, the parking brake lamp is turned off.

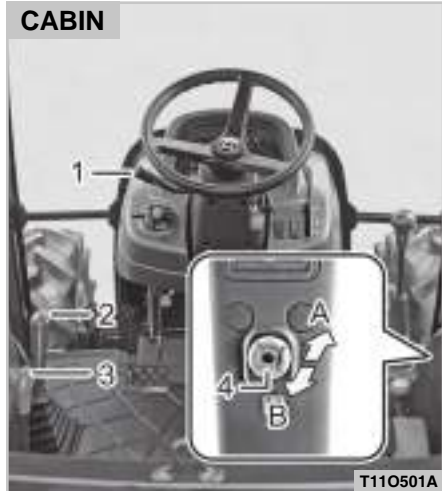

- (1) Forward / Reverse Lever
- (2) Main Shift Lever
- (3) Range Shift Lever
- (4) PTO Switch

3. Place the PTO switch to the "OFF" position. (It cannot be started while the PTO is engaged)

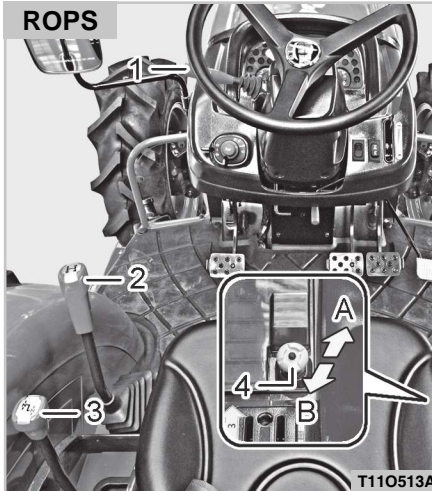

- (1) Forward / Reverse Lever
- (2) Main Shift Lever
- (3) Range Shift Lever
- (4) PTO Switch

4. Set the main, range and shuttle shift levers in the neutral position.

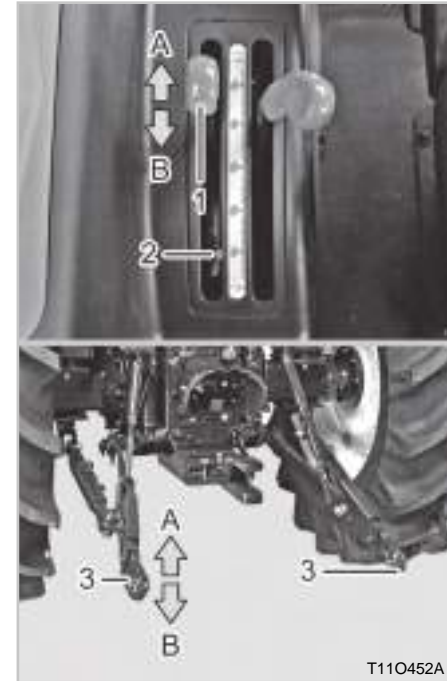

- (1) Position Control Lever
- (2) Lock Bolt
- (3) Lower Link
- (A) Lifting
- (B) Lowering





5. Lower the attachment by pushing the position control lever forward.

**⚠ WARNING**

- *make sure that no one is near the implement or behind the tractor.*



(1) Hand Throttle Lever

: Fast      : Slow

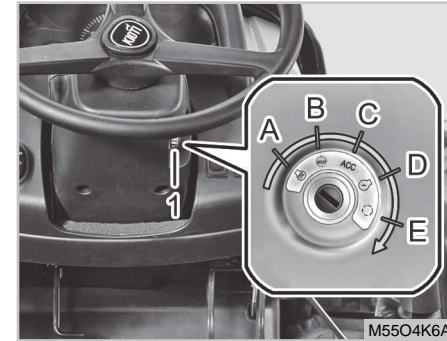

(1) Key Switch    (A) Pre-heat    (B) Stop  
(C) ACC            (D) ON            (E) Start

7. Set the hand throttle lever to the "Slow" position. (In case of cold weather you may adjust it to "Fast" for easier starting)

8. Depress the clutch pedal. (It cannot be started when the clutch is not depressed)

9. Insert the key into the key switch and turn it "ON" and maintain it until the preheat lamp is turned off (approx. 8 sec.).

In case of not enough auto pre-heating, hold the key in "A" (Pre-heat) position for several seconds for manual pre-heat. During the same seconds, the pre-heat lamp on the dash board illuminates.

It is normal that the charge warning lamp and engine oil pressure

warning lamps come on when the key is in "ON" position before the engine start.

### NOTE

Operating principle of auto pre-heating system.

- The glow plug lamp comes on for 8 seconds and then goes off when the key switch is turned to the "Start" or "Stop" position.

The engine should be started within 5 seconds after the glow plug lamp goes off. After the engine is started, post-heat is performed for 15 seconds with the key switch in the "ON" position.

- The post-heating is a function to keep the glow plugs activated for approx. 15 seconds after the engine is started in order to enhance the engine combustion performance and to reduce harmful emissions right after engine start.

### WARNING

- **Never operate the start motor for more than 10 consecutive seconds as it consumes an excess of battery power. If the engine cannot be started within 10 seconds, wait for 30 seconds and try again.**
- **Never try to crank while the engine is running.**

10. When the engine is started, release the key. Then, the key is automatically turned back to the "ON" position.
11. Warm up the engine for 3 to 4 minutes (10 minutes in winter) after releasing the clutch pedal.

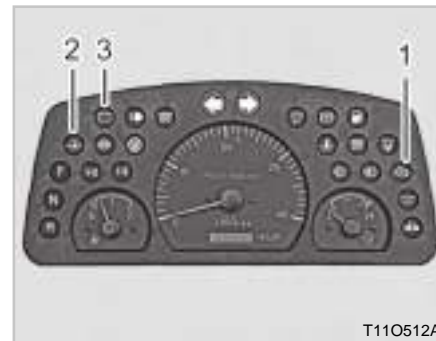

T110512A

- (1) Engine Check Lamp
- (2) Engine Oil Pressure Warning Lamp
- (3) Charge Warning Lamp

12. Check to see that all the warning lamps on the instrument cluster turn "OFF".

If any lamp remains on, immediately stop the engine and determine the cause.



## CheCKING WARNING LAmPS

1. If the oil pressure warning lamp (2) and engine check lamp (1) does not go off in 4 to 5 seconds after the engine is properly started, stop the engine immediately and check the engine oil level. If the engine oil level is proper, contact your local KIOTI Dealer.

### WARNING

- *The engine can be severely damaged if it is ran with the oil pressure warning lamp ON.*

2. If the charge warning lamp (3) does not go off in 4 to 5 seconds after the engine is properly started, it means that the battery is not being charged. Have the charging system, such as the battery and alternator, inspected.
3. Refer to "Instrument panel" in chapter 4 for detailed information about other indicators and lamps.

### WARNING

- *If driving the tractor for an extended period of time with the charge warning lamp ON, the battery can be discharged and the tractor's electrical system can be damaged.*

## STOPPING The eNGINE

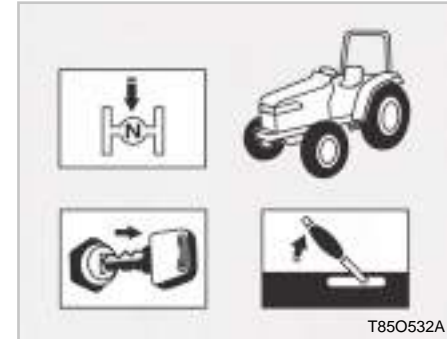

T85O532A

1. Make sure to reduce the engine rpm before stopping the engine.
2. Depress the clutch pedal and put all shift levers in the neutral position.
3. Run the engine at the idle speed for approx. 2 to 3 minutes, and then turn the key switch to the "OFF" position to stop the engine.
4. Remove the ignition key.



### WARNING

- ***Never touch the muffler or hot covers until they are cooled down after running the engine or driving the tractor.***

### Important

- Turn off all the electrical devices and remove the ignition key before leaving the tractor.
- Do not leave the tractor outside unattended. It can be stolen as the key used for all Kioti tractors are the same in shape.
- The horn, turn signal lamp and hazard lamp can be operated without the key inserted. Therefore, using these components without the engine started can discharge the battery.

### Important

- This vehicle is equipped with a turbocharged engine. Avoid high RPM, abrupt acceleration and sudden start immediately after starting the engine. Also, idle the engine for approx. 2 minutes before driving.
- Also, before stopping the engine, idle the engine for approx. 2 to 3 minutes.
- The engine and turbocharger can be damaged prematurely unless idling the engine for a certain period right after it is started and right before it is stopped.

## WARmING UP

It is recommended always to warm up the engine before driving in order to maintain the durability of the engine. Before warming up the engine, make sure that each part in the engine is properly lubricated and each hydraulic part is in a perfect condition in order to prevent malfunction in the engine as well as the hydraulic system.

**hOW TO WARM UP eNGINE (FOR mANUAL TRACTOR)**

1. Start the engine and run it at a low speed and without a load for approx. 3 to 4 minutes.
2. In cold weather, increase the warm up time to 10 minutes.
3. If it is very cold, warm up the engine for approx. 15 minutes.
4. The engine throttle can be open to 50 % in order to shorten the warming up time.
5. The engine is sufficiently warmed up when the temperature gauge on the instrument panel indicates 1/2 of the normal temperature range, regardless of the warming-up time.
6. Do not increase the work load rapidly after starting work.
7. Run the engine without load for approx. 2 to 3 minutes before stopping the engine after work.

**hOW TO WARM UP eNGINE**

1. After starting the engine with the clutch depressed, make sure that the shuttle lever is in its neutral position and release the clutch pedal slowly for warm-up.
2. Run the engine around 1,500 rpm's for the period of time indicated in the table below in accordance with each ambient temperature.

Ambient temperature	Warm-up period
0°C or warmer	5~10 minutes
0°C ~ -10°C	10~20 minutes
-10°C ~ -20°C	20~30 minutes
-20°C or colder	30 minutes or more

**! WARNING**

- *Warming up the engine excessively increases fuel consumption and affects the durability of the tractor negatively.*
- *Never leave the tractor unattended while warming up. It can cause fire and an accident.*

**! WARNING**

- *Be sure to apply parking brake while warming up the engine.*
- *If the warm-up is skipped or missed, the tractor can take off abruptly to cause a fatal accident.*

## JUmP STARTING



(1) Dead Battery      (2) Jumper Cables (-)  
 (3) Jumper Cables (+)      (4) Helper Battery

If the battery is discharged and the engine cannot be started, it is possible to start the engine by connecting the discharged battery to a battery from another tractor or other extra battery.

1. Check that the rated voltage of the discharged battery is same as the voltage of the other tractor or vehicle for jump start (specification for this tractor: 12 V).
2. Check the length of the jump cable and position another tractor near the tractor with the discharged battery. Then, put all the shift levers in the neutral position, apply the parking brake, and stop the engine.
3. Wear protective glasses and gloves and open the hoods of both tractors. Remove the battery terminal cover as necessary.
4. Connect the alligator clips on both ends of the red positive cable to the positive terminals of both batteries.
5. Connect one clip of the black negative cable to the negative terminal of the normal battery and the other clip to the tractor body with the discharged battery.

Make sure to connect the clip to the body part without paint.

6. Start the engine of the tractor with the normal battery.
7. Start the engine of the tractor with the discharged battery.
8. Disconnect the black cable from the negative battery terminals of both of the tractors.
9. Disconnect the red cable.
10. Run the engine for at least 30 minutes to charge the discharged battery.
11. If the battery is discharged again, replace it or check the charging system, such as the alternator.



## OPERATING The TRACTOR HOW TO DRIVE



- (1) Seat      (2) Seatback Adjustment Lever  
 (3) Seat Adjustment Lever (Cushion Weight)  
 (4) Seat Adjustment Lever (Sliding)  
 (5) Seat Adjustment Lever (Height)

1. Adjust the seat and fasten the seat belt.

### ⚠ WARNING

- Check if the seat is securely locked after the seat adjustment.
- Do not adjust the seat while driving. The seat may move suddenly causing the loss of control of the tractor.



- (1) Seat Belt

2. Wear the seat belt.

### ⚠ WARNING

- Always wear the seat belt when cab is installed.
- The seat belt should go around your pelvis or as low as possible, not your waist or abdomen. Otherwise, the seat belt cannot protect you properly.
- Do not wear the seat belt if the ROPS is not installed or folded down.



- (1) Steering Wheel      (2) Tilt Pedal  
 (A) Lifting              (B) Lowering

3. Adjust the steering wheel according to the driver's physique.

### ⚠ WARNING

- Do not adjust the tilt angle of steering wheel while driving. You could lose control of your tractor, causing an accident.

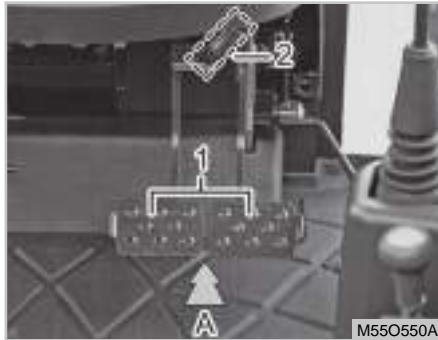

(1) Brake Pedal (LH / RH)  
 (2) Pedal Interlock  
 (A) Depress

4. Make sure both brake pedals are interlocked.

**⚠ WARNING**

- ***If depressing only one brake pedal at a high speed, the tractor can lose its balance and be overturned.***

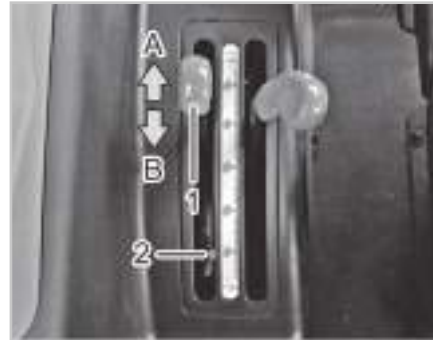

(1) Position Control Lever      (2) Lock Bolt  
 (3) Lower Link      (A) Lifting      (B) Lowering

5. When an implement is attached to the tractor, pull the position control

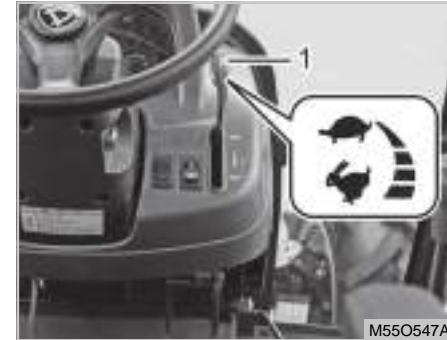

(1) Hand Throttle Lever  
 🐢 "Slow"      🐇 "Fast"

lever to the rear side of the tractor to lift the implement.

6. Increase slowly the engine RPM from idle speed to medium speed.



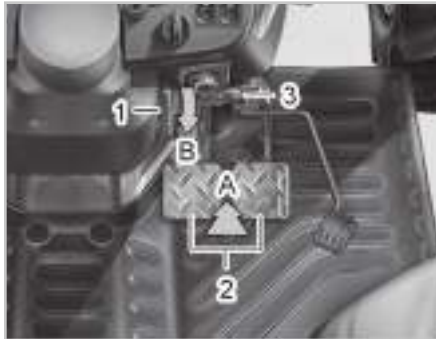

eU



(1) Parking Brake Lever (2) Brake Pedals  
(3) Pedal Interlock  
(A) Depressing (B) Pressing Down

7. Release the parking brake.



M55O537A

(1) Clutch Pedal  
(A) Depress

8. Depress the clutch pedal fully .

**CAUTION**

To avoid accidents:

- Do not release the clutch pedal abruptly. The tractor may start off abruptly, resulting in rollover.



mANUAL

M55O556A

POWeR ShUTTLe



(1) Main Shift Lever (2) Shuttle Lever  
(3) Range Shift Lever

9. Change the main shift lever, range shift lever and shuttle lever

to the position you want.

As this tractor is equipped with the power shuttle system for forward/backward driving, it is possible to shift the main shift and range shift levers without depressing the clutch pedal and then operate the shuttle shift lever.

10. The tractor starts to move if you release the clutch pedal slowly.

**CAUTION**

- **Never rest your foot on the clutch pedal during driving. The clutch disc can be rapidly worn.**
- **make sure to operate the clutch fast when disengaging it and slowly when engaging it.**
- **Do not change the tractor speed abruptly for safe driving.**
- **When driving on a slope or loading or unloading the tractor to a transporting vehicle, reduce the speed in advance so that there is no need to shift the gear in the middle of the slope. Also, do not put your hand on the shift lever while driving on a slope. The tractor may roll down the slope due to the disengaged gear which is very dangerous.**

**PARKING**

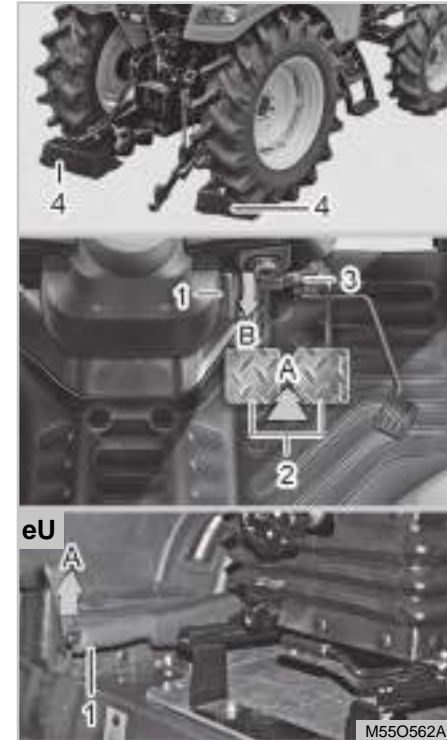

(1) Parking Brake Lever (2) Brake Pedals  
 (3) Pedal Interlock (4) Chocks  
 (A) Depressing (B) Pressing Down



1. For USA/AU model, pull the parking brake lever (1) up with the brake pedals depressed fully to engage the pedals with the latch. If the braking force is insufficient, depress the pedals more firmly. For EU model, pull the parking brake lever (1) up.
2. Before leaving the tractor after parking it, make sure to stop the PTO, lower the implement onto the ground, and stop the engine.
3. If it is necessary to leave the tractor with the engine running, put all the shift levers in the neutral position and apply the parking brake firmly.
4. When parking the tractor on a slope, stop the engine with the parking brake applied and all gears engaged in the low speed position.
5. If it is necessary to park the tractor on a slope with the engine running, apply the parking brake and chock (4) all four wheels.
6. In order to release the parking

brake, push the button of parking brake. For USA/AU model, depress the brake pedals firmly. For EU model, push the button of parking brake and lower the parking brake.

**⚠ WARNING**

- ***The brake pad can be rapidly worn if you drive with the parking brake applied.***
- ***Never park the tractor on a steep slope in any circumstance. A severe accident can occur.***

**⚠ WARNING**

***To avoid possible injury, death or loss of property from a machine runaway:***

- ***With the engine off, the tractor may move unexpectedly regardless of the gear shift position.***
  - ***Before leaving the tractor, certainly apply the parking brake to prevent machine runaway.***
- ※ ***Only power shuttle model.***

### ⊕ ImPORTANT

- The tractor may move slowly with the engine running, even though the main and shuttle shift levers are in the neutral position. This is normal and is due to the fluid friction in the transmission. This symptom can occur easily when the engine rpm is high, the low speed gear is selected by the range shift lever, and the viscosity of the transmission fluid is high due to low temperature. To prevent this symptom, make sure to apply the parking brake.
- Get off the tractor after checking that the tractor is completely stopped and the parking brake is firmly applied.
- Do not park the tractor on tall grass or hay. If grass or hay contacts with the muffler, it can catch fire.

## TURNING

You should turn slowly by reducing vehicle speed.

### ⚠ WARNING

*To prevent accidents due to loss of steering control:*

- *If you turn at high speed, the tractor can turn over.*
- *Never use the differential lock system turning at high and low speeds. A serious accident can occur.*

## DRIVING ON SLOPES

1. Please drive according to the conditions of the slope at safe speed so that the engine is not under heavy load if possible.
2. Make sure to shift to the lower gear in order to prevent the engine from stalling on an uphill.
3. On the downhill slope, drive at low speed.

### ⊕ IMPORTANT

- For a heavy load job, such as front end loader operation, use low speed of the range shift lever.

**⚠ WARNING**

- *make sure the brake pedals are interlocked and differential lock pedal is released.*
- *Do not disengage the clutch or put the shift lever in the neutral position on a steep slope. Otherwise, the tractor may become inoperable. Before entering a steep slope, move the shift lever down to a proper gear and never try to move the shift lever on a slope. A serious accident can occur.*

**PRECAUTIONS When COMING IN AND OUT OF WORK FIELD**

1. Make sure that the left and right pedals are interlocked.
2. Enter and exit the field by driving the tractor at a right angle to the bank.
3. It is recommended to use the 4WD and drive backward when moving onto a bank.

**PRECAUTIONS While DRIVING ON The ROAD**

(1) Turn Signal Light

1. When you change driving direction on the road, let the other car know your direction with turn signal lights.
2. Do not use high beam headlights when another vehicle is approaching from the opposite direction so as not to interrupt the other driver's view.
3. Always interlock the left and right brake pedal while driving on public roads.

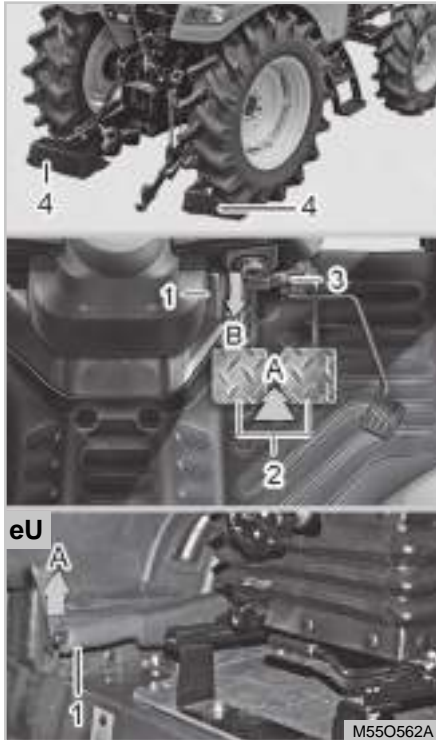

(1) Parking Brake Lever (2) Brake Pedals  
 (3) Pedal Interlock (4) Chocks  
 (A) Depressing (B) Pressing Down

**⚠ WARNING**

- *When you are driving on the road, observe all local traffic and safety regulations.*
- *Only the operator should ride on the tractor unless a passenger seat is installed.*
- *If the tractor breaks down while driving on the road, move it to a safe place with flasher lights blinking. If not, it can cause personal injury.*

**LOADING AND UNLOADING**



1. When you load the tractor, load it by driving backward.
2. If the engine stalls out halfway, step on the brake pedal at once, and then release the pedal slowly to reach the road. After that, start the engine to try to load again.

**⚠ WARNING**

- *When transporting the tractor with a truck, secure the tractor firmly onto the truck and be aware of the height of the loaded tractor to avoid hitting the roof of a tunnel or the bottom of a bridge.*
- *make sure to follow this instruction as such accidents frequently happen.*

**PRECAUTIONS When USING POWER STEERING**

(1) Power Steering Handle

1. The power steering function is activated only while the engine is running. However, the steering wheel becomes slightly difficult when the engine is running at a low speed.  
The steering wheel can be operated but becomes very difficult when the engine is stopped.

2. If you operate the steering wheel with the tractor loaded, using an implement or loader, the steering wheel operation can be somewhat difficult. Operate the steering while tractor is in motion.
3. When a loader is mounted, adjust the air pressure of the front tires to its maximum specification and mount weight or implement on the 3 point hitch of the tractor, and remove the front weight to make the front and rear balance more stable for safe working.
4. When turning the steering wheel to its end, the operating sound of the safety valve (relief valve) can be heard. Do not continue to operate the steering wheel to a maximum right or left turn when you hear the relief valve continually. (OK for a short period of time). The temperature of the hydraulic fluid may rise, causing malfunctions.

### NOTE

The power steering system in this tractor is a load reaction, full hydraulic type.

- The full hydraulic system means that power necessary for power steering is transferred by hydraulic fluid only and therefore mechanical devices, such as rack and pinion, are not installed on the tractor. Therefore, the angle of the **KIOTI** emblem on the center of the steering wheel may differ occasionally, which is normal.
- The load reaction type means that the reaction force or impact applied to the front axle is transferred to the steering wheel. Therefore, the steering wheel can be returned to its straight-forward position from the turning position.

### WARNING

- *When driving on a road with an implement attached to the rear of the tractor, the contact of the front wheels becomes poor, resulting in poor steerability. In this case, attach a proper front weight and drive at a low speed.*
- *If a malfunction occurs while driving on a road, stop the tractor in a safe place and service it. If it is not possible to move the tractor, turn on the hazard lights and set a warning triangle behind the tractor. Otherwise, a rear end accident may occur.*

### WARNING

- *The center of gravity of the tractor is higher compared to other common vehicles, so the possibility of a roll-over accident is very high. Be extra careful when driving on a lateral slope, bumpy road, road with puddles, and narrow road. make sure to set the ROPS in its original position (straight up position) and fasten the seat belt.*
- *If stopping the engine while driving, the steering performance can become deteriorated due to loss of hydraulic power, resulting in a severe accident. Never stop the engine while driving.*
- *Always grip the steering wheel using both hands while driving.*





### 3-POINT hITCh CONTROL SYSTEm POSITION CONTROL

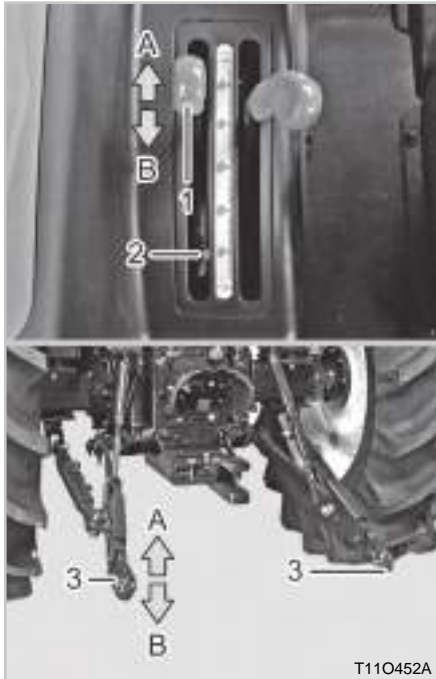

(1) Position Control Lever      (2) Lock Bolt  
(3) Lower Link  
(A) Lifting                              (B) Lowering

The 3-point hitch can be controlled by the position control lever.

1. The position control lever is used to lift or lower the lifting arm (lower link) of the 3-point hitch.
2. Pushing the lever forward lowers the lower link while pulling the lever backward lifts the lower link.
3. The height of the lower link is precisely controlled proportional to the position of the lever.

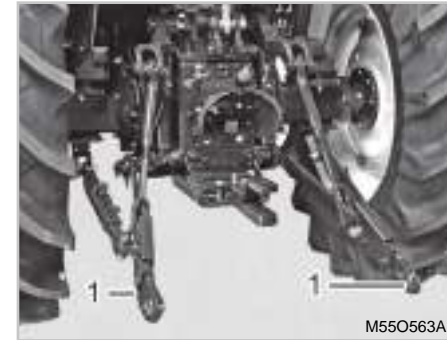

(1) Lower Link

5

4. The lower link is lifted by the hydraulic energy of the tractor while it is lowered by potential energy of its own weight. Therefore, the implement cannot be lowered by the hydraulic pressure.
5. Therefore, the implement attached to the lower link may be lifted by the ground when it is moving across the ground. This is called as "floating".



(1) Lowering Speed Control Knob  
 (A) High Speed      (B) Low Speed

6. The lowering speed of the lower link is proportional to the applied weight but can be controlled by adjusting the draining passage of the hydraulic fluid. (See "Lifting arm speed control knob" on Page 4-32)

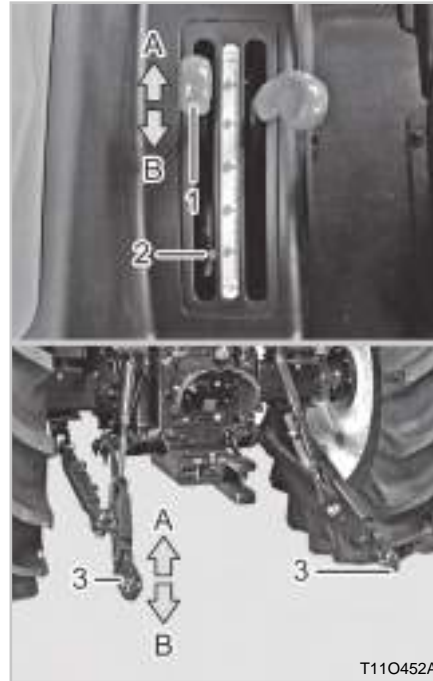

(1) Position Control Lever      (2) Lock Bolt  
 (3) Lower Link  
 (A) Lifting      (B) Lowering

7. The lower limit of the implement's height can be set by limiting the

movement of the control lever using the stop bolt.

**⚠ WARNING**

- *If trying to lift an object with excessive weight by the 3-point hitch while the tractor is not equipped with proper front seat case weights, the front wheels may be lifted instead, leading to roll over. make sure to follow the specifications for use.*



## DRAFT CONTROL

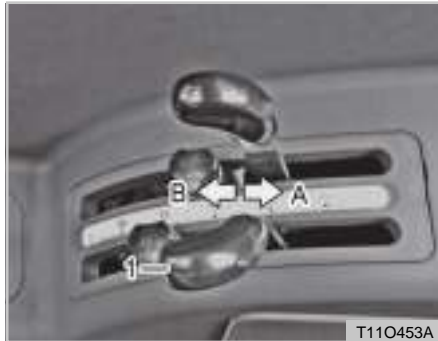

(1) Draft Control Lever  
(A) Lifting (B) Lowering

1. The draft control function is used to prevent the wheels from spinning and the engine from stopping due to excessive draft load when the tractor is used for work which requires a lot of draft, such as plowing.

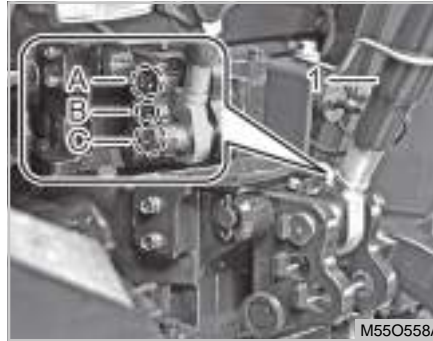

(1) Top Link  
(A) Traction Power Is Not Required (Rotary Etc.)  
(B) Heavy Load Traction Work  
(C) Normal Load Traction Work

- The draft function is activated when the lowest or middle hole on the top link of the 3-point hitch is used. The middle hole is for sensitive draft control.
- To keep the plowing depth shallow, put the draft control lever to the rear (shallow) position.  
The plowing depth tends to become deeper naturally by outer conditions. When the load increases by

the increase of the plowing depth while the draft control lever is set to the "Shallow" position, the plowing depth is maintained as shallow because the reaction force is transferred to the internal system via the top link and the lifting arm is automatically lifted.

- To keep the plowing depth deep, put the draft control lever to the front (deep) position.
- The position of the draft control lever should be different based on the condition of soil to keep the plowing depth constant.

When working on a new field, it is recommended to put the draft control lever to the proper position for the desired plowing depth and lock the lever with the lock bolt.

- When using an implement which requires no draft function, such as a rotary tiller and mower, use the highest hole on the top link and put the draft control lever in any position.

7. However, if the draft control lever is pushed forward to its end, the lowest position of the lifting arm can be lowered a little. On the other hand, if the lever is pulled back to its end, the highest position of the lifting arm can be raised a little.

**CAUTION**

- If the lifting arm is properly operated but abnormal noise is still heard, the hydraulic system may be malfunctioning. In this case, let the engine idle for an 10 to 15 minutes additionally and then try to start the engine again. If the problem is still present, contact your local KIOTI Dealer.

**CAUTION**

- The implement may shake up and down as the draft sensor is under impact when the tractor is passing over irregular ground with the middle or lowest top link hole selected. In this case, put the draft control lever to the "Deep" position to decrease the sensitivity of the draft function or select the highest top link hole.
- If the tractor has been stored for a long period of time or the transmission fluid is just changed, abnormal noise may be heard and the hydraulic lifting arm may be inoperable temporarily. In this case, let the engine idle for 3 to 4 minutes.

**RemOTe hYDRAULICS  
DOUBLe ACTING vALVe**

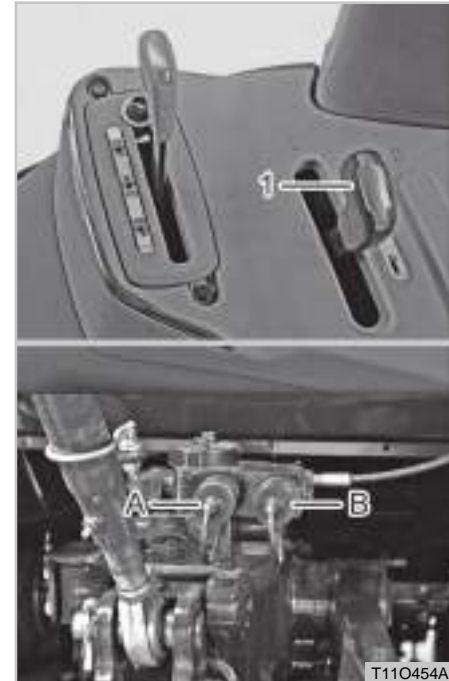

(1) Double Acting Valve 1 & Lever 1  
(A) Port A (B) Port B

**KIOTI** supplies self-return type of the double acting valves.



- For the self-return type double acting lever, it returns to its original position to block the hydraulic fluid when it is pushed/pulled and then released. However, this type of double acting valve lever should be pulled or pushed continuously for operation which is suitable for an implement with a short operating time, such as the hydraulic cylinder.

Optionally, **KIOTI** is supplying the secondary remote valve such as Detent or self return types of valve.

While you add a detent type of valve to your tractor, when the relief valve starts to operate by operating the double acting lever, put the lever into the neutral position immediately. If the relief valve operates continuously, the oil is overheated, leading to damage to related parts.

### DOUBLE ACTING Lever

Pressure  $\Rightarrow$  Returning  $\leftarrow$

Level 1		Push	Pull
Valve 1 port	A	Out $\Rightarrow$	In $\leftarrow$
	B	In $\leftarrow$	Out $\Rightarrow$

Coupler Size	
Port A, B	PT 1 / 2

#### ⊕ IMPORTANT

- **Put the detent valve operating lever into the neutral position when the hydraulic implement is not in use. If the detent valve is kept in the operating position for an extended period of time, the relief valve is kept open and the temperature of the hydraulic fluid rises, leading to damage of various hydraulic parts, such as the oil seals and O-rings.**

#### ⊕ IMPORTANT

- **When the detent valve is in operation, unnecessary load is applied to the engine. Therefore, the engine power decreases significantly, and noise and vibration by opening of the relief valve increases.**
- **It is hard to start the engine while the detent valve is in operation. This is especially true in winter and exhaust gas increases even after the engine is started.**

## SINGLE ACTING AND DOUBLE ACTING CYLINDER

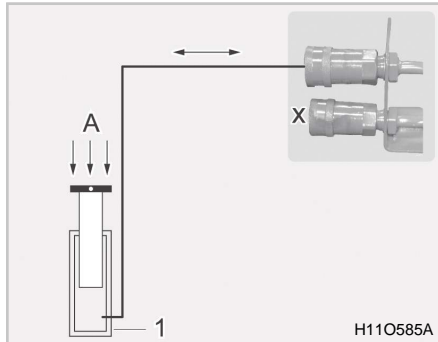

(1) Single Acting Cylinder  
(A) External Load

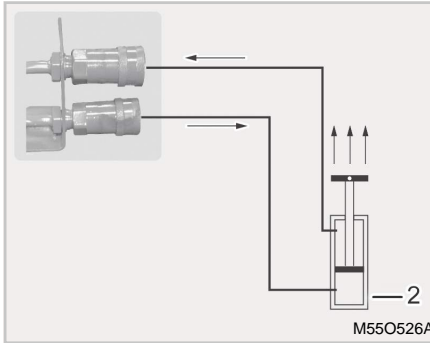

(2) Double Acting Cylinder

This tractor is equipped with the remote control valve of the double acting type. However, this valve can also be used in the single acting type hydraulic cylinder.

1. Connect one end of the hydraulic port to the single acting cylinder as shown in the figure. The hydraulic pressure is properly supplied to the cylinder. However, when the hydraulic pressure is released, the cylinder is contracted only if there is outer force, such as potential energy.

2. To contract the cylinder, operate the lever to the opposite direction of the expansion. Then, the hydraulic fluid is supplied from the hydraulic pump to the hydraulic port which is not connected, and the pressure rises as the port is blocked. However, this pressure is released as the relief valve opens.

3. When the cylinder is contracted, the hydraulic fluid returned from the cylinder is drained to the transmission through the draining circuit

as the operating lever is operated to the opposite direction from the expansion position.

### ⊕ ImPORTANT

- It is recommended to use the double acting cylinder instead of the single acting cylinder if the implement will be operated frequently and continuously. If using the single acting cylinder too frequently or for an extended period of time, the hydraulic fluid can be overheated, resulting in deterioration of the hydraulic parts' durability as the main relief valve opens at cylinder contraction.



## CONNECTING AND DISCONNECTING IMPLEMENT CONNECTION

1. Make sure to stop the engine before connecting implements.
2. Move the double acting valve lever forward and backward for 4 to 5 times to release the pressure in the hydraulic line of the tractor. Otherwise, it is hard to connect the couplers, and hydraulic fluid can be sprayed from the line and get in to your eyes while connecting them.
3. Remove any foreign material around the male and female couplers. If foreign material enters the hydraulic components, it can lead to malfunction of the system.
4. Open the dust-proof cover of the female coupler of the tractor and insert the male coupler of the implement. A clicking sound is heard when the couplers are engaged.
5. Pull the hydraulic hose of the implement to check that the couplers are properly connected.
6. Start the engine and check the operating status and leakage.

## DISCONNECTION

1. Make sure to stop the engine before disconnecting implements.
2. Release any residual pressure in the hydraulic hoses of the implement and tractor by operating the double acting valve lever 4 to 5 times.
3. Remove any foreign material around the couplers.
4. Lower the implement on the ground or remove any external load applied to the implement. Disconnecting hoses while outer load is applied to the implement is very difficult and dangerous due to the pressurized fluid in the hose.
5. Remove the male coupler by pushing the female coupler boss backward.
6. Close the dust-proof cover of the female coupler. Wrap the male coupler of the implement with a plastic bag to prevent contamination.

### WARNING

- ***Never connect or disconnect the implement hydraulic hose while the pressure in it is not released or the engine is running. It is hard to connect and disconnect the hose and hydraulic fluid can be sprayed from the hose, and get into your eyes or skin.***
- ***Stop the engine and wear protective glasses and gloves before work.***



memO







## 3-POINT hITCh ImPLemeNT AND LOADeR OPeRATIOn

# 6

### RemOvAL AND INSTALLATIOn OF 3-POINT hITCh ImPLemeNT (WiTh PTO ShAFT) .. 6-2

### OPeRATIOn TIP FOR 3-POINT hITCh eLemeNTS .. 6-5

ADJUSTMENT OF LIFT ROD .....	6-5
ADJUSTMENT OF TOP LINK .....	6-6
PRECAUTION FOR INSTALLING / HOW TO USE TOP LINK HOLES.....	6-6
ADJUSTMENT OF STABILIZER .....	6-7
DISMOUNTING THE IMPLEMENT .....	6-7
DRAW BAR AND TRAILER .....	6-7
INSTALLING PTO SHAFT .....	6-9

### hANDLING LOADeR ..... 6-11

FIXATION POINTS FOR FRONT END LOADER .....	6-12
DRIVING ON SLOPES .....	6-13
JOYSTICK LEVER .....	6-14
JOYSTICK VALVE PORT .....	6-17

# 6



## RemOVAL AND INSTALLATION OF 3-POINT hITCh ImPLement (WITH PTO ShAFT)



(1) *Implement Support*

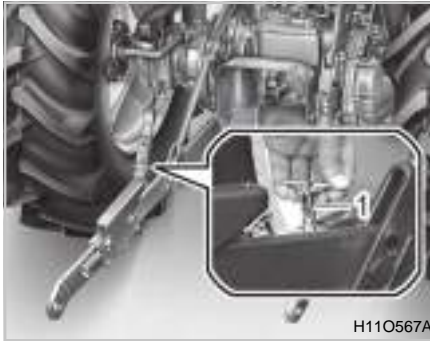

(1) *Telescopic Stabilizers Pin*



(1) *Latch*                      (2) *Lower Link End*

1. Drive the tractor backwards to move close to an implement (approx. 5 cm). Then, adjust the height of the lower link to be parallel to the pins of the implement.
2. Put all the shift levers in the neutral position, stop the engine, and apply the parking brake.

3. Remove both of the Telescopic Stabilizers fixing pins.

**⊕ ImPORTANT**

- **When removing/installing an implement, remove the check link pin to use the lower link end (cassette type) effectively.**

4. Press the latch to pull out the lower link end. (Cassette type)





(1) Lower Link



(1) Lower Link End



(1) Top Link  
(2) Lock pin

(3) Snap Pin

5. Install the lower link to the implement and fit the pins.

6. Start the engine and drive backward toward the implement. Then, the lower link end is inserted to its original position.

7. Separate the top link from its bracket and turn it to adjust its length so that it becomes close to the upper bracket mounting hole of the implement. Then, fit it to the mounting hole, insert the lock pins, and secure it with the snap pin. Remove the implement support as necessary.



(1) Telescopic Stabilizers Pin

8. Turn the top link to balance the implement. Then, move the implement to the left and right, and secure it into the proper position by fitting the telescopic stabilizers lock pin
9. Connect the PTO shaft to the tractor's PTO if necessary. At this time, stop the engine, lower the implement onto the ground, and set the PTO gear neutral.

### ⊕ ImPORTANT

- **Consult your local KIOTI Dealer for selection of the PTO shaft.**
- **When selecting a PTO shaft, make sure there is a minimum of 6 inches (152mm) of overlap of the PTO shaft tubes when the shaft is extended to its maximum working length between the tractor and the piece of equipment. Also make sure there is 3 inches (76mm) of clearance between the shaft tube ends and the universal joints at both ends when the PTO shaft is at its shortest working length between the tractor piece of equipment. If not, DO NOT USE the PTO shaft and contact a KIOTI dealer.**
- **move the joint back and forth to check that its lock pin is properly seated to the groove of the PTO shaft.**

10. Remove the implement in the reverse order of installation and use the implement support as necessary.



### OPERATION TIP FOR 3-POINT HITCH eLEMENTS



(1) Top Link  
(2) Lift Rod

(3) Check Link  
(4) Lower Link (L)

(5) Lower Link (R)  
(6) Draw Bar

M55O618A

### ADJUSTMENT OF LIFT ROD

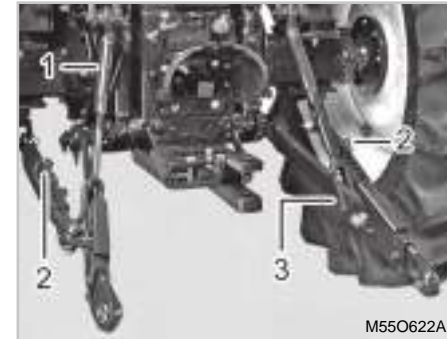

M55O622A

(1) Lift Rod  
(3) Pin

(2) Check Link

1. Adjust the implement height by turning the lift rod after removing the pin.
2. After adjustment, secure it with the pin.

6



## ADJUSTment OF TOP LINK



(1) Top Link                      (2) Set Pin  
(3) Retainer Pin                (4) Top Link Handle

1. Install the top link to the desired position, and install the pin and retainer pin.
2. Unscrew the lock nut of the top link hole end. To increase the length, turn the top link handle clockwise. To decrease the length, turn it counterclockwise. Finally, secure the top link with the lock nut.

## PRECAUTION FOR INSTALLING / hOW TO USE TOP LINK hOLEs

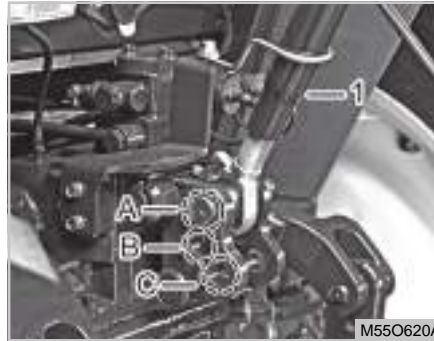

(1) Top Link

When attaching an implement, connect it according to its draft as follow:

- A : Draft is not required.
- B : Heavy load traction work
- C : Normal load traction work

1. Adjust an angle of the implements to the desired position by shortening or lengthening the top link.
2. Adjusting top length varies according to the type of implements used.

### ⚠ CAUTION

- A plate describing how to attach the implement is placed on the standard implement of our company.
- When you are attaching an implement not requiring draft, mount the top link into hole A.
- When you are attaching an implement (like plow) requiring some traction, mount the top link into the hole B or C.
- When moving with an implement attached, make sure to set the top link to the hole "A" or place the draft control lever to the foremost (deepest) position. Otherwise, the draft control system may operate, resulting in damage to the lifting control section or unintentional lowering of the implement by it self.

**ADJUSTMENT OF STABILIZER**

(1) Check Link      (2) Pin

1. Adjust the check link to control horizontal sway of the implement. It is also used to set the implement on the back of the tractor in center.
2. To adjust the check link, pull out the pin and adjust it until the desired transverse moving distance is obtained.
3. Fit the pin to the gardening hole (fixed) for normal operation and long hole (moving) for draft work.

**DISMOUNTING THE IMPLEMENT**

1. Park the tractor with the implement on level ground and lower the implement all the way down.  
Install the implement support as needed.
2. Disconnect the top link and lower links from the implement by removing the pins.
3. Be sure to insert the set pins, lynch pins and snap pins back to the implement securely to keep those safe.
4. Stop the engine and move the remote hydraulic control lever back and forth to relieve the hydraulic pressure in the system before disconnecting hydraulic couplers.
5. Put the top link back to its hook.  
Hold both lower links together with a rubber "strap" or "tie down". Otherwise, the lower links can contact with rear tires and cause damage to the lower links and tires while driving.

**DRAW BAR AND TRAILER**

(1) Draw Bar

The draw bar is used to pull an implement, such as a trailer. Make sure to check the max. towing weight of the trailer and max. vertical load that can be applied to the draw bar.

- Max. trailer weight (trailer + loaded weight) = 3,000 kg (6,614 lbs)
- Vertical load on the draw bar = 750 kg (1,653 lbs)

**⚠ CAUTION**

- When using an implement that is attached to the draw bar, such as a trailer, make sure the towing hitch is firmly attached.

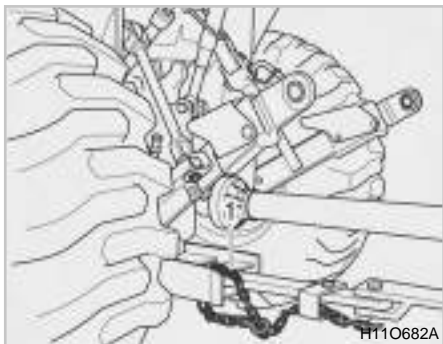

H110682A

(1) Safety Chain

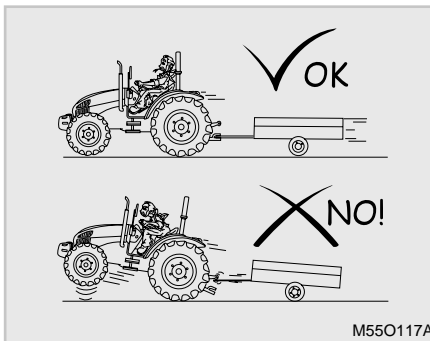

M550117A

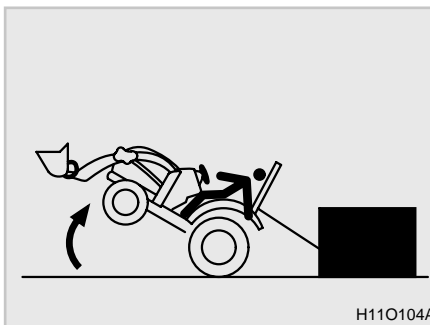

H110104A

**⚠ WARNING**

- *Never use any other part for pulling except draw bar. Pulling with top link, ROPS and etc. will cause a fatal accident.*
- *Be sure to install the auxiliary safety chain when installing a trailer.*
- *Improper use of the draw-bar, even if correctly positioned, can cause a rear overturn.*
- *Do not overload an attachment or towed equipment. Use proper counterweights to maintain tractor stability. hitch heavy loads to the draw-bar only.*





## INSTALLING PTO Shaft

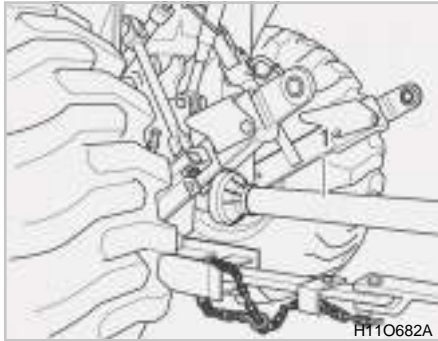

(1) PTO Shaft

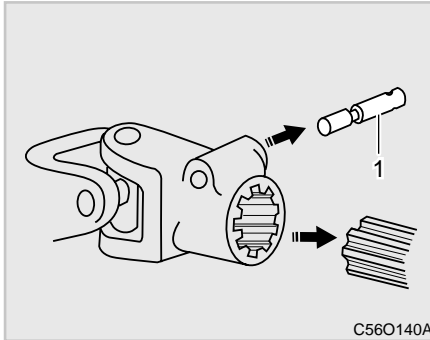

(1) Lock Pin

1. Consult your local **KIOTI** Dealer for selection of the PTO Shaft.
2. When selecting a PTO Shaft, make sure that it is not too short to come off of the female and male shafts at the highest position or too long to impact its female and male shafts at the lowest position.
3. Move the joint back and forth to check that its lock pin is properly seated to the groove of the PTO shaft.

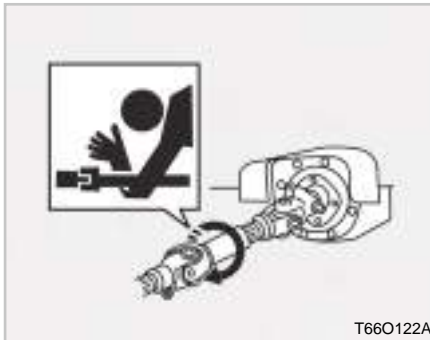

### **⚠ WARNING**

- *make sure that the PTO safety cover is in its position before driving the PTO shaft.*
- *The tractor PTO and PTO shaft should not be interfered by any surrounding parts.*
- *Never go close to the rotating PTO or tractor PTO shaft. A severe accident can happen.*
- *Before driving an implement through the PTO, always make sure that all bystanders are well away from the tractor.*
- *When using the PTO drive with a stationary tractor, always make sure that the gears are in neutral and that the parking brake is applied.*

**⚠ WARNING**

- **Before starting up any PTO-driven implement hitched to the three-point linkage, lift the implement to its full height and check that at least 1/4 of the total length of the telescopic section of the drive shaft is engaged.**

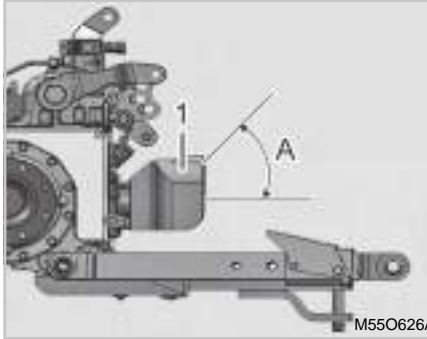

(1) PTO Cover

(A) Allowable angle of universal joint : 50°

Ref to the chart below as to installing of an universal joint.

The type of PTO shaft	Allowable angle of universal joint
SAE 1-3 / 8" 6 splines	50 degree



## hANDLING LOADeR



- (1) *Loader Mounting Bracket*
- (2) *Boom Cylinder*
- (3) *Loader Arm*
- (4) *Boom*
- (5) *Grill Guard*
- (6) *Bucket Cylinder*
- (7) *Bucket*

For detailed information about installation and use of the front loader, refer to the separate manual of the loader.

### **+** ImPORTANT

- **Check the transmission fluid level and add fluid as necessary after installing an attachment or implement related to the hydraulic fluid, such as a loader or backhoe, and driving the tractor for a test.**

## FIXATION POINTS FOR FRONT eND LOADeR

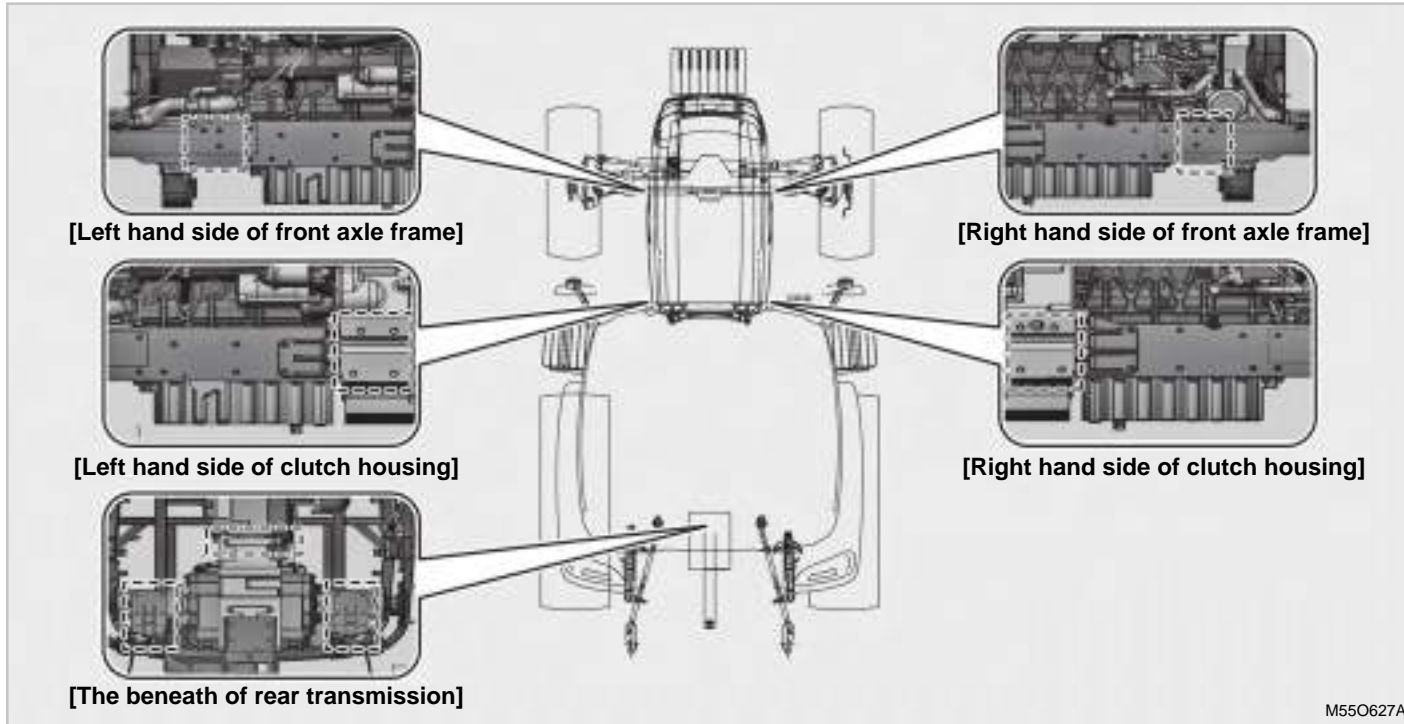

### WARNING

- When you do install the front loader, install the bolts for the mounting bracket at the indicated points.



### DRIVING ON SLOPES

#### When LOADED BUCKET AND REAR BALLAST ARE INSTALLED

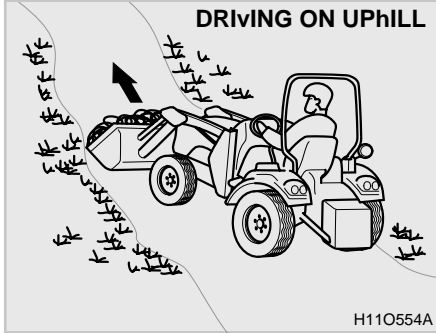

When driving uphill with a loaded bucket and rear ballast installed, keep the bucket end of the tractor uphill. In other words, drive forward on uphill and backward on downhill.

#### **! WARNING**

*To avoid injuries:*

- *Keep the loader arm as low as possible when driving on a slope.*

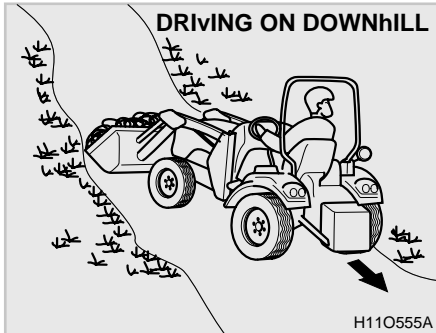

#### When UNLOADED BUCKET AND REAR BALLAST ARE INSTALLED



When driving downhill with an empty bucket and rear ballast installed, keep the rear ballast toward the higher level of the ground. In other words, drive backward on uphill and forward on downhill.

Use the 4WD to increase traction when driving on a slope with a loaded bucket and rear ballast installed.

Set the bucket and implement as low as possible for vehicle stability and safety while driving unless there are obstacles along the way.

### PARKING WITH LOADeR INSTAlLeD

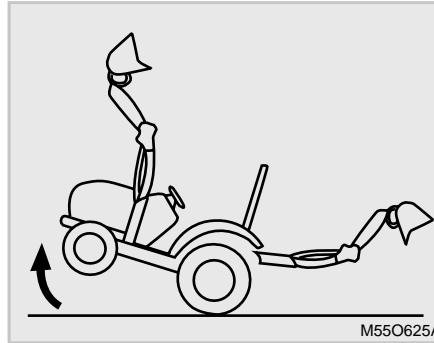

### JOYSTICK LeVeR



(1) Joystick Lever

### ⚠ CAUTION

- When parking a tractor which is equipped with a loader or backhoe, make sure that the bucket of loader or backhoe is lowered on the ground. Otherwise, the tractor can become unstable, leading to an unexpected accident, such as roll over.

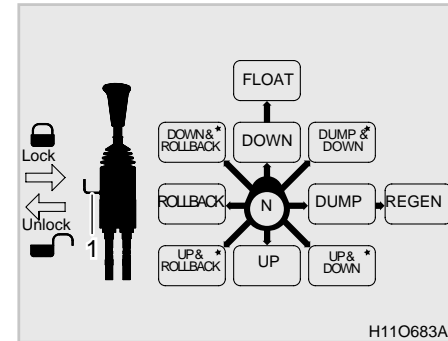

(1) Joystick Lock Lever

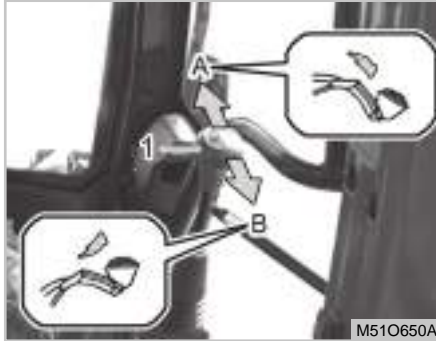

(1) Joystick Lever  
 (A) Boom Down      (B) Boom Up

### 1. Up and down of boom

Pulling the joystick lever back (B) lifts the boom of the loader while pushing it forward (A) lowers the loader boom.

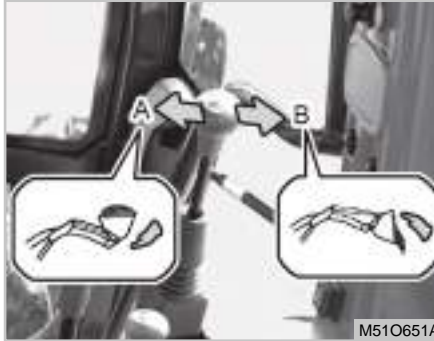

(A) Bucket Roll Back      (B) Bucket Dump

### 2. Roll back & Dump

"Roll back" means that the bucket scoops up. To operate this function, move the joystick lever to the left (A). "Dump" means that the bucket dumps. To operate this function, move the joystick lever to the right (B).

### 3. Float

The floating function is activated when the joystick lever is pushed one position further to forward from the down position. When the lever is in this position, the boom moves up and down freely along the surface of the ground as the hydraulic line is opened from the valve to the boom cylinder. This function is useful when removing soft objects on hard ground (for example, when removing snow or sand on paved road).

#### **⚠ WARNING**

- ***If moving the lever to the floating position while the boom is up in the air, the boom can fall freely and lead to an accident.***

#### 4. Regen.

The regen function is activated when the joystick lever is pushed one position further to the right from the dump position. The regen means "fast dumping".

#### 5. Down & Roll back

The boom can be lowered and the bucket can be rolled back at same time by operating the joystick lever to the front left position (10 o'clock position). However, the operation time may not be shortened much since the boom is lowered first and then the bucket is rolled back later due to unbalanced hydraulic pressure in the hydraulic circuit.

#### 6. Down & Dump

The boom can be lowered and the bucket can dump at same time by operating the joystick lever to the front right position (2 o'clock position). However, these two operations may not be performed simultaneously due to unbalanced hydraulic pressure in the hydraulic circuit.

#### 7. Up & Roll back

The boom can be lifted and the bucket can scoop up at same time by operating the joystick lever to the rear left position (7 o'clock position). However, these two operations may not be performed simultaneously due to unbalanced hydraulic pressure in the hydraulic circuit.

#### 8. Up & Dump

The boom can be lifted and the bucket can dump at same time by operating the joystick lever to the rear right position (5 o'clock position). However, the operation time may not be shortened much since the bucket dumps first and then the boom is lifted later due to the unbalanced hydraulic pressure in the hydraulic circuit.

#### 9. Locking / Unlocking joystick

Pressing the joystick lock lever in, locks the joystick, while pulling it outward, unlocks the joystick as shown in the figure.

### WARNING

- ***Do not leave the tractor with the boom off the ground in any circumstances. If it is necessary, lock the joystick.***
- ***When the joystick lever is not in use, lock it since the implement can fall down if the lever is operated accidentally.***

### ImPORTANT

- **If the boom or bucket is not operating properly, lower the bucket onto the ground, stop the engine and move the joystick lever to remove all hydraulic pressure in the system. Then, check all the hydraulic connections and reconnect them correctly.**
- **Before connecting or disconnecting the hydraulic hose coupling from the loader, lower the boom onto the ground, stop the engine, and move the joystick lever front and back, left and right for several times to remove residual pressure in the hydraulic hose.**





## JOYSTICK vALve PORT

**⚠ WARNING**

- *Pressurized diesel fuel or hydraulic fluid may be sprayed on your skin or eyes, leading to a severe injury or even death.*
- *To fix leaks, use a board and wear protective gloves and goggles.*
- *If your eyes come into contact with the hydraulic fluid, seek medical attention immediately.*
- *Never try to disconnect the tube and quick coupler while the tractor and implement are in operation. Release the pressure by operating the lever after the engine is stopped.*

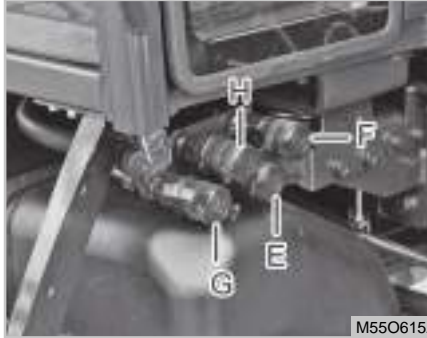

(E) Bucket Up  
(G) Boom Up

(F) Bucket Down  
(H) Boom Down

PORT	DIReCTION	FUNCTION
E		Bucket Up
F		Bucket Down
G		Boom Up
H		Boom Down



memO

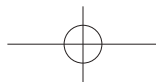



# *mAINTeNANCe*

# 7

## **mAINTeNANCe CheCk LiST ..... 7-3**

- DAILY CHECK CHART..... 7-3
- MAINTENANCE SCHEDULE CHART..... 7-4

## **LUBRICANTS ..... 7-7**

## **mAINTeNANCe CODe ..... 7-8**

- HOW TO OPEN THE HOOD (A) ..... 7-8
- CHECKING AND ADDING FUEL (C) ..... 7-8
- CHECKING TRANSMISSION  
FLUID LEVEL (D) ..... 7-9
- CHECKING ENGINE OIL LEVEL (E) ..... 7-10
- CHECKING COOLANT LEVEL (F)..... 7-11
- CLEANING GRILL, RADIATOR SCREEN (G).. 7-12
- CHECKING BRAKE AND  
CLUTCH PEDALS (H)..... 7-12
- CHECKING GAUGES, METER AND  
EASY CHECKER (I) ..... 7-13
- CHECKING HEAD LIGHT, HAZARD  
LIGHT ETC. (J)..... 7-13
- CHECKING SEAT BELT AND CABIN (K)... 7-13

- CHANGING ENGINE OIL AND  
REPLACING FILTER (L) ..... 7-13
- REPLACING TRANSMISSION  
FLUID AND FILTER (M) ..... 7-15
- INSPECTION FRONT  
AXLE CASE OIL (N1) ..... 7-17
- CHANGING FRONT AXLE CASE OIL (N).. 7-17
- ADJUSTING BRAKE PEDAL (O) ..... 7-18
- LUBRICATING GREASE LOCATIONS (P)... 7-19
- CHECKING WHEEL  
BOLT/NUT TORQUE (Q)..... 7-20
- ADJUSTING CLUTCH PEDAL (R) ..... 7-20
- REPLACING FUEL FILTER (S)..... 7-21
- REPLACING AIR CLEANER  
PRIMARY ELEMENT (T)..... 7-21
- REMOVING WATER FROM  
FUEL FILTER (T1) ..... 7-22
- BLEEDING FUEL LINES (T2) ..... 7-23
- CHECKING FUEL LINES (U) ..... 7-24
- ADJUSTING FAN BELT TENSION (V)..... 7-25
- BATTERY (W)..... 7-26
- CHECKING INTAKE AIR LINE (X) ..... 7-28
- ADJUSTING TOE-IN (Y) ..... 7-28



## *mAINTeNANCe*

CHECKING RADIATOR	
HOSE AND CLAMP (Z) .....	7-29
POWER STEERING LINE (AA).....	7-30
AIR CONDITIONER BELT TENSION (AB) ...	7-30
CLEANING AIR CONDITIONER	
CONDENSER (AC) .....	7-31
ADJUSTING FRONT AXLE PIVOT (AD)....	7-31
ADJUSTING ENGINE VALVE CLEARANCE (AE).....	7-31
REPLACING AIR CLEANER FILTER (AF) ..	7-32
CHECKING AIR CONDITIONER HOSE (AG) ...	7-32
CHECKING CAB CUSHION RUBBER (AH)...	7-32
REPLACING AIR FILTER (AI) .....	7-33
FLUSH COOLING SYSTEM AND CHANGING COOLANT (AJ) .....	7-33
ANTI-FREEZE .....	7-34
DRAINING WATER FROM CLUTCH HOUSING (AL).....	7-35
CHECKING AND REPLACING WIPER (AP).....	7-36
REPLACING FUSE (AN).....	7-38
REPLACING CABIN FUSE (AO).....	7-39
SLOW BLOW FUSE (AP).....	7-41
MAIN FUSE (AS).....	7-41
REPLACING BULB (AQ).....	7-42
CHECKING REFRIGERANT (AR).....	7-47
AIR CONDITIONER MAINTENANCE (AS) ..	7-47
TURBOCHARGER (AU).....	7-48



## mAINTeNANCe CheCK LIST

### DAILY CheCK ChART

SeRvIce SCheDULe		mAINTeNANCe CODES
ITem	SeRvIce ReQUIReD	
Engine Oil	Check the oil level and add as needed. Do not overfill.	E
Hydraulic (Trans / Diff.) Fluid	Check level and add as needed.	D
Engine Air Filter and Air In- take System	Check for leaks and damaged components. Do not use compressed air to clean elements.	T
Engine Cooling System	Clean debris from oil cooler, radiator screen and grills. Check coolant level cold, add premixed coolant as needed.	F, G, AC
Seat Belt	Check the condition of seat belt and mounting hardware. Repair or replace as needed.	
Tires	Check for wear, damaged tires and ensure for proper sized tires and correct air pressure.	
Parking Brake	Check operation and adjust if required.	
Clean Pedals	Clean brake pedals, travel control pedal, clutch pedal and footrest area.	H
General Items	Check for loose or broken parts, damaged operator cab, instrument operation, loose wheel nuts / bolts, oil leaks and damaged or missing signs (decals).	Q, AG, AH, AM
PTO	Inspect the splines. Replaced damaged or missing shields and guards.	
Three-point Linkage	Check operation and condition of pins, links and bars.	
Loader (If Equipped)	Check mounting hardware for loose or broken parts.	

※ For detailed information about maintenance codes, refer to the corresponding section in each chapter.

### mAINTeNANCe SCHeDULe ChART

NO.	Item	maintenance interval	Run hour									Run age		Remarks	maintenance-codes	
			10	50	100	200	400	600	800	1500	3000	1Year	2Year			
1	Engine oil & Filter	Change				○										L
		Check	◉													
2	Transmission oil filter	Replace		◉		○										M
		Change					○									M
3	Transmission fluid	Check	◉													D
		Change					○									N
4	Front axle oil	Change					○									
5	Front axle pivot	Adjust						○								
6	Engine start system	Check		○												
7	Greasing	Apply		○												P
		Check	○													
8	Wheel bolt torque	Check	◉	○												Q
9	Battery condition	Check				○								* 3		W
10	Air cleaner element	Check	○													T
		Clean		○									* 1	#		T, AF
		Replace				○					○		* 2			
11	Fuel filter element	Replace				○									#	S
12	Fan belt, Air-con belt	Adjust				○								* 3		V, AB
13	Clutch pedal free play	Adjust		◉		○										O
14	Brake pedal free play	Adjust		◉		○										R
15	Radiator hose and clamp	Clean	◉													G
		Check				○										Z



NO.	Item	maintenance interval	Run hour									Run age		Remarks	maintenance codes	
			10	50	100	200	400	600	800	1500	3000	1Year	2Year			
15	Radiator hose and clamp	Replace											○			Z
16	Power steering hose and oil line	Check				○										AA
		Replace												○		
17	Fuel line	Check				○									#	U
		Replace												○		
18	Intake air hose	Check	◉			○									* 3	X
		Replace												○		
19	PTO shaft and guard condition	Check	◉			○										
20	3 point hitch and draw-bar condition	Check	◉			○										
21	Secure pins	Check	◉			○										
22	Tire pressure and damage	Check	◉			○										
23	Parking brake condition	Check	◉			○										
24	Toe-in	Adjust				○										Y
25	Engine valve clearance	Adjust							○							AE
26	Fuel injection nozzle injection pressure	Check								○					#	
27	Injection pump	Check									○				#	
28	Cooling system	Clean												○		AJ

NO.	Item	maintenance interval	Run hour									Run age		Remarks	maintenance codes		
			10	50	100	200	400	600	800	1500	3000	1Year	2Year				
29	Coolant	Check	⊙														AJ
		Replace											○				
30	Air-con filter	Replace										○					AI
31	Fuel system	Check													* 3		C
32	Fuse	Replace													* 3		AN, AO, AP, AS
33	Light bulb	Replace													* 3		AQ

**⊕ ImPORTANT**

- ⊙ must be done after the first 10 or 50 hours of operation.
  - \* 1 Air cleaner should be cleaned more often in dusty conditions than in normal condition.
  - \* 2 every year or every 6 times of cleaning.      \* 3 Replace only if necessary.
- The items listed above (# marked) are registered as emission related critical parts by KIOTI in U.S. EPA exhaust emission standard non-road emission regulation. As the engine owner, you are responsible for the performance of the required maintenance on the above instruction.
- The components that have major impact on the tractor performance should be serviced by your local Dealer. (The performance can be deteriorated, leading to a serious accident)
  - \* Major component: Components in engine, transmission, hydraulic system and electric system.





## LUBRICANTS

To prevent serious equipment damage, use only genuine **KIOTI** fluids, oils and greases, or equivalents.

No.	Section	Capacity [U.S.gal. (L)]	Lubricants
1	Fuel	25.1 (95)	Unleaded diesel
2	Coolant	2.4 (9.1)	An anti freezing solution (Ethylene glycol) + Pure water (50:50)
3	Engine oil	2.2 (8.3)	Oil specification : API CH grade above Oil viscosity : SAE 10W30, 10W40, 15W4
4	Transmission oil	15.9 (60)	Daedong : UTF 55 Shell : Donax-TD, Exxonmobil : Mobilfluid 424 Exxon Hydraulic 560 BP : Tractran UTH
5	Front axle oil	2.2 (8.5)	SAE 90 gear oil or better, or same as T/M oil
6	Apply grease • Front axle support • Brake pedal • Brake lever • Top link holder • Control lever	A little	SAE Multi purpose type grease

### WARNING

- **Check the oil level regularly. Correct the oil level, if needed, before operating.**
- **Always check and add oil with the tractor on a flat, level surface.**



## mAINTeNANCe CODE hOW TO OPeN The hOOD (A)



T110736A

- (1) Hood
- (2) Opening Knob
- (A) Pull
- (B) Lift

1. It is very easy to open the hood with one touch pulling knob.
2. The hood stays open by itself with an air cylinder. To close it, just press down.



M550753A

- (1) Hood

 **CAUTION**

- **Never open the hood while the engine is running.**

## CheCKING AND ADDING FUEl (C)



T110701A

- (1) Fuel Tank Cap

The fuel tank is installed in the middle of the tractor body. Make sure to use high-quality diesel fuel.

Fuel Tank Capacity
25.1 U.S.gal. (95 L)



1. Turn the key switch to "ON", check the amount of fuel by fuel gauge.
2. If the needle on the fuel gauge is close to "E" or the fuel level is low, open the fuel tank filler cap and add fuel.
3. After adding the fuel, close the fuel tank filler cap.

### ⚠ CAUTION

To avoid personal injury:

- Do not smoke while refueling.
- Add the fuel in a well-ventilated area.
- Be sure to stop the engine before refueling.
- Dirt or sand contained in fuel may cause the fuel injection pump to malfunction, use a strainer when refuelling.

### ⊕ IMPORTANT

- Be careful not to let the fuel tank become empty, otherwise air will enter the fuel system, necessitating bleeding before next engine start.
- Be careful not to spill during refueling. If a spill occurs, wipe it off at once, or it may cause a fire.
- If unit is not used for a long time, make sure the fuel viscosity is suitable for the cold weather.

## CheCKING TRANSmISSION FLUID Level (D)

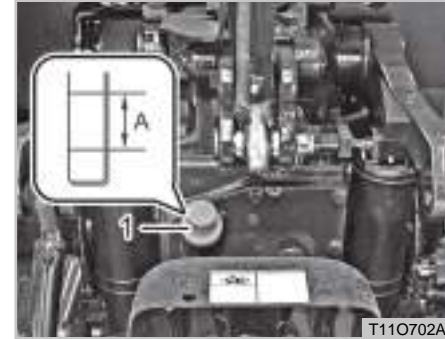

- (1) Oil Dipstick & Filler Plug  
(A) Oil level is acceptable within range

1. Park the machine on a flat surface, lower the implement.
2. Depress the brake pedals and apply the parking brake.
3. Set all shift levers into the neutral position.
4. Stop the engine.

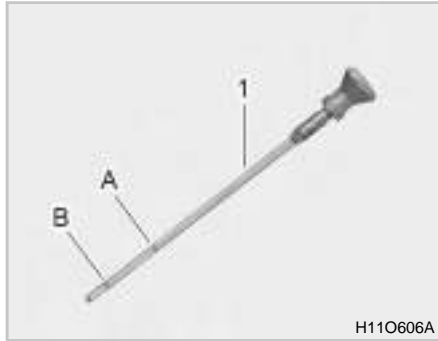

(1) Oil Dipstick  
 (A) Upper Limit  
 (B) Lower Limit

5. Pull out the oil dipstick, clean it, and then insert it into its original position. Pull it out again and check if the oil level is within the specified range.
6. If the oil level is too low, add some new oil so that the level is within the allowable range. (Refer to "Replacing transmission fluid and filter" in this chapter for fluid specs.)

### ⊕ IMPORTANT

- If oil level is low, do not run engine.
- Never add the oil over the upper limit.
- Be sure to check the oil level after installing hydraulic implement. Add the fluid as needed.
- Check the oil level with the cylinders of an implement extended and check again with cylinders retracted. Add the oil to adjust average oil level in the range of the oil limit (upper or lower).

### CheCKING eNGINE OIL Leve L (e)

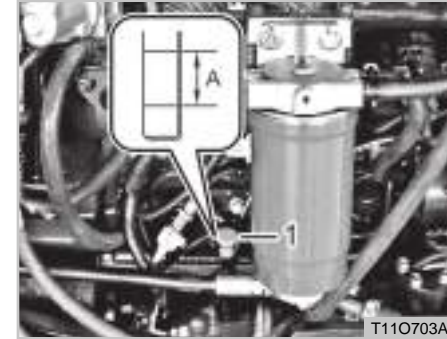

(1) Oil Dipstick  
 (A) Oil level is acceptable within this range

1. Check the engine oil daily.
2. Park the tractor on level ground and lower the implement.
3. If the engine was just running, wait for approx. 5 minutes before checking the oil level.

### ⚠ CAUTION

To avoid personal injury:

- Be sure to stop the engine before checking the oil level.



(1) Oil Dipstick  
(A) Upper Limit (B) Lower Limit

- Pull out the oil dipstick, clean it, and then insert it into its original position. Then, pull it out again and check if the oil level is within the specified range.
- If the oil level is too low, add some new oil so that the level is within the allowable range.

### ⊕ ImPORTANT

- When using oil of different make or viscosity from the previous one, remove all of the old oil. Never mix two different types of oil.
- Do not start the engine when the oil level is below the lower limit.
- Wipe the oil dipstick with a clean cloth or tissue. If foreign material enters the oil sump, it can lead to malfunction of the engine.
- Never add the oil over the upper limit.

### CheCKING COOLANT Level L (F)

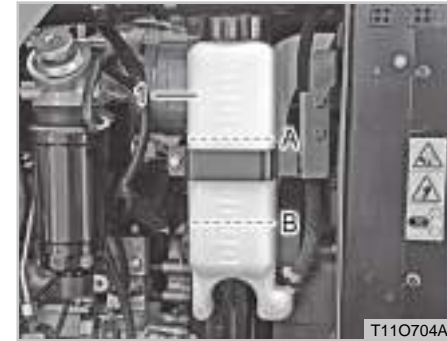

(1) Reservoir Tank  
(A) FULL (B) LOW

- Check to see that the coolant level is between the "FULL" and "LOW" marks of the reservoir tank.
- When the coolant level drops due to evaporation, add water only up to the middle of the range.  
In case of leakage, add anti-freeze and water in the specified mixing ratio up to the middle of the range.
- The tractor is furnished in the factory with a mixture of anti-freeze (ethylene glycol) and water in a ratio of 50:50 which is usable in any season.

## CLeANING GRILL, RADIATOR SCReeN (G)



(1) Radiator Screen  
(A) Detach

(2) Bolt

1. Check front grill and side screens to be sure they are clean of debris.
2. Lift out the radiator screen and remove all the foreign material.

### CAUTION

To avoid accidents:

- Be sure to stop the engine before removing the screen.

### ImPORTANT

- Bonnet Grill and screen must be clean from debris to prevent engine from overheating and to allow good air intake for the air cleaner.

## CheCKING BRAKe AND CLUTCh PeDALS (h)

1. The brake and clutch pedals should be inspected for free travel, and smooth operation.
2. You should adjust these pedals if an incorrect measurement is found. (See maintenance code "O" and "R" in this chapter)

### NOTE

- When depressing the brake pedals separated, both of the brake pedals should be moved down to the same depth.

**CheCKING GAUGeS, meTeR AND eASY CheCkeR (I)**

1. Inspect the instrument panel for broken gauge(s), meter(s) and Easy Checker lamps.
2. Replace if broken.

**CheCKING heAD LIgHT , hAZ-ARD LIgHT eTC. (J)**

1. Inspect the lights for broken bulbs and lenses.
2. Replace if broken.

**CheCKING SeAT BeL T AND CABIN (K)**

1. Always check condition of seat belt and cabin attaching hardware before operating tractor.
2. Replace if damaged.

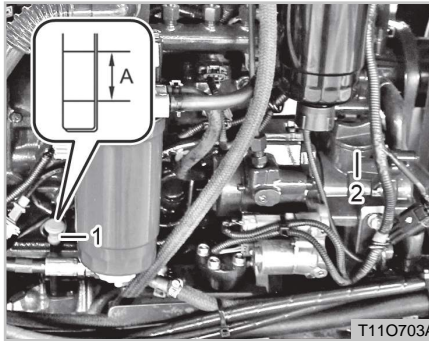
**ChANGING eNGINE OIL AND RePLACING FILTeR (L)**

(1) Oil Dipstick (2) Engine Oil Filler Cap  
(A) Oil level is acceptable within this range

1. Park the tractor on level ground and start the engine to warm it up.

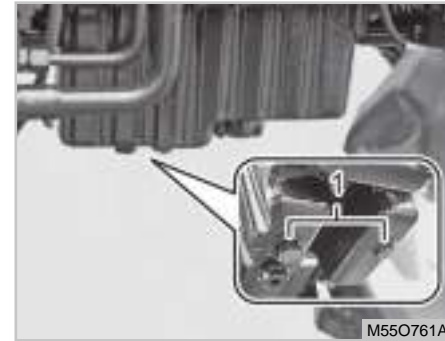

(1) Drain Plug

2. Stop the engine, apply the parking brake and place the container under the tractor.
3. Wait until the oil is cooled down.
4. Take off engine oil filler cap to allow easy draining for engine oil.
5. Remove the drain plugs at the bottom of the engine and drain the oil completely. All the used oil can be drained out easily when the engine is still warm. Be sure to install the drain plugs(X2) to the oil pan securely.

Allowable torque: 4~4.5kgf.m



(1) Engine Oil Filter

6. Remove the oil filter behind the cooling fan on the right side of the engine.
7. Apply a thin film of oil to the O-ring of a new filter and tighten the new filter firmly by hand.
8. Fill the engine oil to the specified level and tighten the oil filler cap.

#### Oil Capacity (Including Filter)

2.2 U.S.gal. (8.3 L)

9. Run the engine for approx. 5 minutes to deliver oil to each part.
10. Stop the engine if the oil warning lamp still comes on. (It is normal for the oil warning lamp to be off while the engine is running)
11. Check the engine oil level with the oil dipstick. If the level is low, add more oil.

#### NOTE

- The engine oil filter should be replaced when changing the engine oil.

#### WARNING

- *The engine oil is very hot while the engine is running or right after the engine is stopped. Be careful not to be burned.*
- *Avoid oil contact while changing or adding engine oil and wear eye protection to prevent eye contact.*
- *Prolonged and repeated contact with the engine oil may cause skin disorders and skin cancer. If skin contact is made, wash thoroughly with soap or hand cleaner as soon as possible.*
- *Keep the used oil out of reach of children.*





## RePLACING TRANSMISSION FLUID AND FILTER (m)

### ⚠ CAUTION

- To avoid personal injury, be sure to stop the engine before changing the oil or replacing the filter.
- Check the engine oil level before every operation of the tractor. If the engine oil is insufficient, the engine can be damaged, and this is not covered by warranty. Be sure to add engine oil when its level is below the lower mark of the oil dipstick.
- Do not dispose of used oil and oil filter into drainage and other places not designated by regulations. Observe applicable regulations when disposing used oil and filters.

### ⊕ IMPOR-

- Use only specified engine oil and KIOTI genuine filter to insure smooth operation and durability of the engine.



(1) Oil Filter Cartridge



(1) Drain Plug

The transmission fluid should be changed if it is contaminated or after the transmission is serviced or every 400 hours of operation. When changing the transmission fluid, make sure to change the fluid filter. However, replace the filter only at initial 50 hours and every 200 hours of operation afterward.

1. Park the tractor on level ground and start the engine to warm it up.
2. Stop the engine, apply the parking brake and wait until the oil cools down.

3. To drain the used fluid, place the oil container under the transmission case and remove the drain plug to drain used fluid. If the fluid does not flow out freely, unscrew the air bleeding plug on the side of the hydraulic cylinder on the left of the top link bracket to facilitate drainage. Reinstall the drain plugs securely afterward.

4. Unscrew the fluid filter from the rear right section on the tractor using a filter wrench.

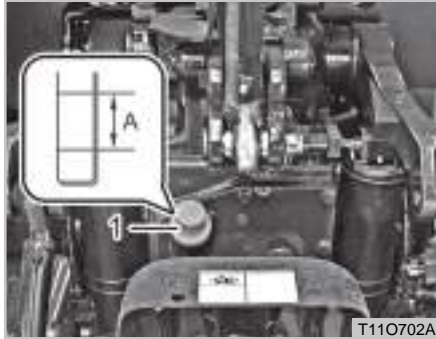

T11O702A

(1) Oil Dipstick & Filler Plug  
(A) Oil level is acceptable within range

5. Apply a thin film of clean oil onto the O-ring of a new filter.
6. Tighten the filter firmly by hand.
7. Run the engine for a few minutes and then shut engine off to check for leaks and fluid level. Add fluid to the specified level as needed.

**Oil Capacity**

15.9 U.S.gal. (60 L)

**⚠ CAUTION**

To avoid personal injury:

- Be sure to stop the engine before changing the fluid or replacing the filter.
- Cool down the fluid sufficiently. You can get burned by hot fluid.

**⊕ ImPORTANT**

- To prevent serious damage to the hydraulic system, use only a KIOTI genuine filter.
- Do not operate the tractor with heavy load right after changing the transmission fluid. Run the engine at medium speed for a few minutes to prevent damage to the hydraulic system.



T11O707A

(1) Air Bleeding Hose

**⊕ ImPORTANT**

- When adding the fluid, unscrew the bleeding plug on the top of the hydraulic cylinder. Otherwise, the fluid can overflow.

**INSPeCTION FRONT AXLe CASe OIL (N1)***(1) Oil Filler Plug*

1. Remove the filling plug from the front axle.
2. Check the oil level with the level gauge of the filler plug.
3. If the oil level is too low, add new oil to the allowable level.

**ChANGING FRONT AXLe CASe OIL (N)***(1) Drain Plug**(2) Air Bleeding Plug*

1. To drain the used oil, remove the right and left drain plugs and filling plug at the front axle case and drain the oil completely into the oil pan.
2. After draining, reinstall the drain plugs securely.
3. Remove the oil level checking plug on the left of the front axle.

4. Add new oil to the specified level through the oil filler.
5. Wait at least 15 minutes to allow the oil flow to the bevel case before checking the oil level .
6. Add oil as necessary and tighten the oil filler plugs and oil level checking plug.

**Oil Capacity**

2.2 U.S.gal. (8.5 L)

## ADJUSTING BRAKE PeDAL (O)



(1) Brake Pedal  
(A) Free Play

Adjust the brake pedal free play periodically. Refer to the "Maintenance schedule chart" for checking interval. The brake pedal can be adjusted as follows:

1. Release the parking brake and unlock the pedal inter-lock.
2. Slightly depress the pedals by hand to measure the free play.

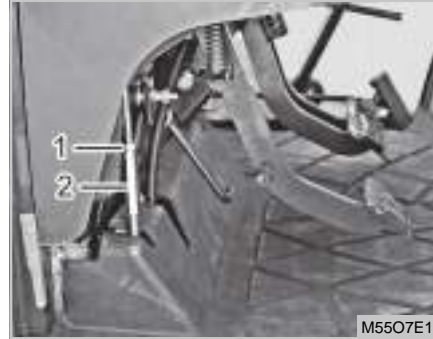

(1) Lock Nut                      (2) Turn Buckle

3. When adjustments are needed, loosen the locking nut and turn the turn buckle until the rod length is at the desired and acceptable limit.
4. Re-tighten the lock nuts.
5. Perform the same procedure for the left brake pedal to make both free play the same.
6. Interlock the brake pedals after checking or adjusting them.

**Proper  
brake  
pedal  
free travel  
(A)**

0.591 ~ 1.181 in.  
(15 ~ 30 mm)

Keep the free play in  
the right and left brake  
pedals equal.

### CAUTION

To avoid personal injury:

- Stop the engine and chock the wheels before checking brake pedal.



### LUBRICATING GREASE LOCATIONS (P)

Apply high-quality multi-purpose grease onto the positions in the figure at every 50 hours of operation or whenever necessary.

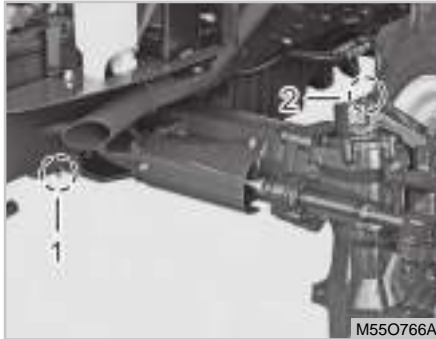

(1) Front axle support bracket (FRT)  
(2) Front axle case support (LH)

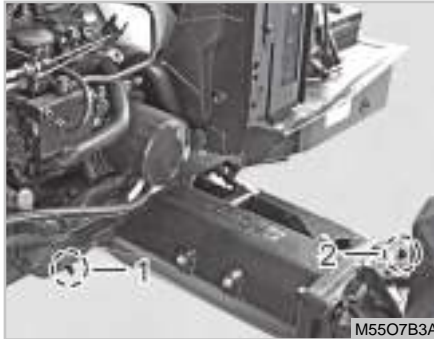

(1) Front axle support bracket (RR)  
(2) Front axle case support (RH)

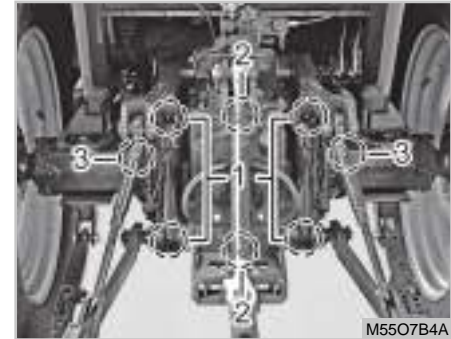

(1) Hydraulic cylinder (upper/lower)  
(2) Top link (upper/lower) (3) Lift rod (LH/RH)



(1) Brake shaft (LH)



(1) Brake shaft (RH)

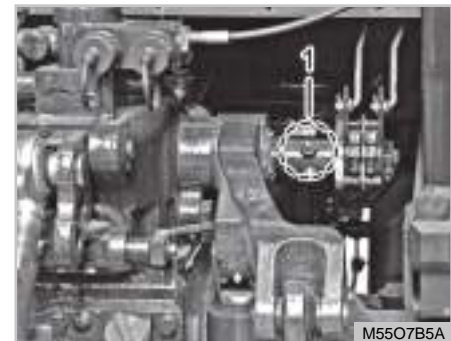

(1) Pitman arm support

### CheCKING Wheel BOL T/NUT TORQUe (Q)



(1) Front Wheel Bolt / Nut  
(2) Rear Wheel Bolt / Nut

Check wheel bolts and nuts regularly especially when new. If they are loose, tighten them as follows.

Item		Tightening Torque
Front wheel	Bolt/Nut	196 ~ 225 N·m 144 ~ 166 lbf·ft 20 ~ 23 kgf·m
Rear wheel	Bolt/Nut	275 ~ 319 N·m 203 ~ 235 lbf·ft 28 ~ 32.5 kgf·m
Front Rim	Bolt/Nut	260 ~ 304 N·m 192 ~ 224 lbf·ft 26.5 ~ 31 kgf·m

#### CAUTION

To avoid personal injury:

- Never operate tractor with a loose rim, wheel, or axle.
- Any time bolts and nuts are loosened, retighten to specified torque.
- Check all bolts and nuts frequently and keep them tight.

### ADJUSTING CLUTCh PeDAL (R)



(1) Clutch Pedal (2) Clutch Cable  
(3) Lock Nut (A) Free Play

1. If the clutch does not operate properly due to its excessive play, or periodically, adjust its play.



2. To adjust the play, unscrew the lock nut and adjust the clutch cable
3. After setting the play properly, tighten the lock nut firmly.

**Proper clutch pedal free play (A)**

0.8 ~ 1.2 in. (20 ~ 30 mm)

**RePLACING FUEl FILTeR (S)**

(1) Fuel Filter

(2) Drain Plug

1. Wipe the surface of the fuel filter thoroughly to remove foreign materials.
2. Unscrew the plug on the bottom of the fuel filter to drain fuel.
3. Remove and replace the fuel filter with a new one.

**RePLACING AIR CleANeR PRI-MARY eLeMeNT (T)**

(1) Element

(2) Cap

(3) Evacuator Valve

1. The air cleaner uses a dry element. Never apply oil.
2. Dust should not accumulate in the dust cap or element. Remove and clean the dust cap and the element every week. If the tractor is operated in extremely dusty conditions, daily inspection is required.
3. Do not touch the filter element except in cases where cleaning is required.

4. When cleaning the element, refer to the instructions that follow.

To clean the element, use only clean dry compressed air on the inside of the element. Air pressure at the nozzle must not exceed 29 psi (2 kgf/cm<sup>2</sup>). Maintain reasonable distance between the nozzle and the filter.

### ⊕ ImPORTANT

- **The air cleaner will only fulfill its function if it is correctly and regularly maintained. A poorly maintained air cleaner will mean loss of power, excessive fuel consumption and a reduction in engine life.**
- **Do not run the engine with filter element removed.**
- **Be sure to refit the cap with the arrow ↑ (on the rear of cover) upright. If the cap is improperly fitted, evacuator valve will not function and dust will adhere to the element.**

### ⊕ ImPORTANT

- **Be sure to check any air leak or opening in the air intake system. Even the small gap or opening in the air intake system can cause the serious engine problems after a few years of operation.**

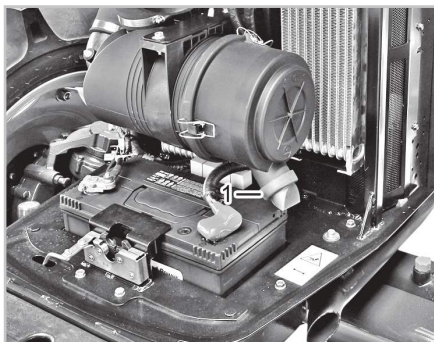

(1) Evacuator valve

### ev ACUATOR vALVe

Open the evacuator valve gap once a week under ordinary conditions or daily when used in dusty conditions to get rid of large particles of dust and dirt.

## RemOvING WATeR FRom FUEl FILTeR (T1)



(1) Fuel Filter

(2) Drain Plug

1. Water and dust in fuel are accumulated in the filter. Remove the plug from the bottom of the fuel filter to drain any impurities.
2. After draining, tighten the plug by hand.
3. Start the engine and check for fuel leakage.



**BLEEDING FUEL LINES (T2)**

(1) Drive Pump

(2) Air Plug

1. Make sure that the amount of fuel in the fuel tank is sufficient.
2. If air is produced in the pre-filter or main filter, unscrew its bleeding bolt (2), illustrated above, and turn the ignition switch to run the start motor. Then, air in the fuel filter is bled through the bleeding bolt as shown in the figure above.

**⚠ CAUTION**

- Avoid running the start motor for over 5 consecutive seconds, but run it several times at shorter intervals.

**📖 NOTE**

- Bleeding is not necessary if installing the fuel port after fueling.

3. When fuel is visible from the bleeding bolt, tighten the bolt and start the engine.

**⊕ IMPORTANT**

Keep the following instructions to protect the catalytic filter:

- Make sure to use only approved fuel.
- Keep the engine oil change schedule.
- Check the engine oil amount frequently and keep its level to the specification.
- Avoid unnecessary idling of the engine.

**⊕ IMPORTANT**

Keep the following instructions to protect the catalytic filter:

- Never stop the engine during driving.
- Never place the shift lever in the neutral position on a downhill.

**⊕ IMPORTANT**

- Do not use any engine oil or fuel additive except Polar D + Diesel power additives.
- Avoid driving for an extended period of time with any warning lamp illuminated.
- Make sure that any flammable material, such as dry grass or paper, gets to the catalytic filter while parked.

**⚠ CAUTION**

- Never bleed the fuel system while the engine is hot.

### ⊕ ImPORTANT

- After bleeding, fuel without air bubbles is filtered by the fuel filter and is transferred to the fuel injection pump. Maintain the proper fuel level in the fuel tank before the fuel tank becomes empty. If all fuel is completely consumed in a Diesel engine, fuel should be added to the fuel tank and then the fuel system should be bled.

### 📖 NOTE

- If the engine cannot be started even after bleeding the fuel system, contact your local Dealer.

## CheCKING FUEl LINEs (U)



(1) Fuel Pipe

(2) Tightening Band

Although checking the fuel pipe connection is recommended every 100 service hours, it should be done every 6 months if operation does not exceed 100 hours in 6 months.

1. If the hose clamps are loose, apply a slight coat of lubricant onto the threads and securely tighten it.
2. The fuel pipe is made of rubber and ages regardless of period of service. Change the fuel pipe to-

gether with the hose clamps every two years and securely tighten.

3. If the fuel pipes and hose clamps are found damaged or deteriorated earlier than two years, then change them immediately.
4. After the fuel pipe and hose clamps have been changed, bleed the fuel system.

### ⚠ WARNING

- **Stop the engine when checking the items above.**
- **The fuel pipes are subject to wear and aging. Failure to perform periodic inspections may lead to a fuel leak. Fuel leaking on a hot engine could cause a fire.**



## ADJUSTING FAN BELT TENSION (v)

### ⊕ ImPORTANT

- When changing fuel pipes, be careful not to allow dust or dirt to enter the fuel system. Contaminations in the fuel system could damage the fuel system or injection pump. Pay extra caution to the fuel pump to prevent dust from entering it.

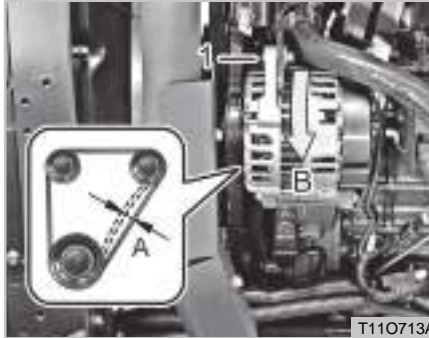

(1) Adjusting Bolt  
(A) Adjusting Belt Tension

(B) Pull

In order to extend the fan belt life-time, the tension of the belt should be correctly adjusted. The belt tension should be inspected regularly according to the following procedure:

1. Stop the engine and apply the parking brake.
2. Open the hood.
3. Apply moderate thumb pressure to the belt (A) between the crankshaft pulley and alternator pulley to check for tension.

### Belt deflection for proper fan belt tension (A)

0.39 ~ 0.47 in. (10 ~ 12 mm)

4. If tension is incorrect, loosen the alternator mounting bolt and hinge bolt. Pull the alternator outward using a pry bar to reach the proper belt tension.
5. Be sure to retighten the alternator mounting bolt and hinge bolt securely after adjusting belt tension.
6. Replace the fan belt if it is damaged, cracked or worn.

### ⚠ CAUTION

To avoid personal injury:

- Be sure to stop the engine before checking belt tension.

## BATTeRY (W) PReCAUTIONS FOR hANDLING



(1) Battery

Mishandling the battery shortens the service life and adds to maintenance costs. If the battery is insufficiently charged, the headlights may dim and the engine is hard to start. It is important to inspect the battery periodically.

1. The battery cables should always be clean and firmly connected. When installing a new or used battery, clean its terminals.
2. Check the battery and cable for damage and corrosion.

3. Apply grease to the terminals and cable end in order to prevent corrosion.

### ⚠ WARNING

- **The battery gas can explode. Do not expose the battery to flames or sparks. It may cause a fire.**
- **The battery fluid contains sulfuric acid that can burn you. Do not allow the battery fluid to contact your eyes, skin, or painted surfaces. If you accidentally get it in your eyes or on your skin, flush with water and contact your doctor.**
- **Be sure to wear eye protection while working on the battery. The battery fluid can hurt your eyes.**
- **Use only the battery with the specified voltage. Otherwise, it may cause a fire.**

## INSPeCTION



(1) Battery

(2) Sight Glass

Check the battery sight glass frequently to keep the battery in the best condition.

- Blue: Battery normally charged
- Black: Battery discharged, immediate charge required
- White: Battery replacement required

※ Standard for a battery provided from DAEDONG.



## ChARGING

1. To slow charge the battery, connect the battery positive terminal to the charger positive terminal and the negative to the negative, and then recharge in the standard fashion.
2. Boost charging is only for emergencies. It will partially charge the battery at a high rate and in a short time. Doing this will shorten the battery's service life.
3. When the battery is discharged and should be replaced, replace it with a new one with same specification and capacity.

Battery type	volts (v)
100AH	12

## CAUTION

- **The charge warning lamp comes on if the charging system is defective. If it comes on while driving, have the system checked or repaired by your local KIOTI Dealer.**
- **Keep the battery fully charged. If the battery fluid concentration is too low during the winter season, the battery may be frozen.**
- **Do not start the engine when the battery is frozen. Try to warm it up first.**
- **If the battery is not securely installed, the battery case and electrolytes could be damaged by vibration. To prevent the battery acid from contacting the terminals, apply grease around the battery terminals and connections.**
- **Never check the charge status of the battery by placing a metal object across the posts. Use a voltmeter or hydrometer.**

## DIReCTION FOR STORAGE

1. When storing the tractor for a long period, remove the battery from tractor, store in a dry place out of direct sunlight.
2. The battery self discharges while it is stored.

Recharge it once every three months in hot seasons and once every six months in cold seasons.

### CheCKING INTAKE AIR LINE (X)

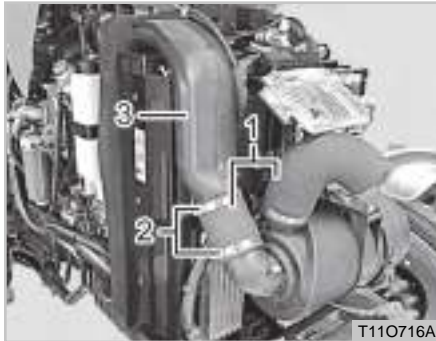

(1) Air Line Hose

1. If the hose clamps are loose , tighten clamps securely.
2. If the hoses and clamps are damaged, you must replace them at once. Failure to do so could lead to engine damage.
3. Check the following section.

Section	Inspection item
Air cleaner – intake manifold	Loose clamp and damaged hose

### ADJUSTING TOE-IN (Y) ADJUSTING PROCeDURE

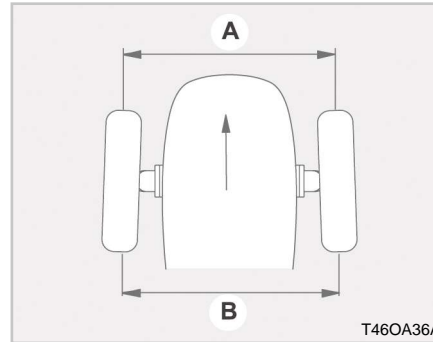

(A) Wheel - to - wheel distance at front  
(B) Wheel - to - wheel distance at rear

1. Park tractor on a flat surface
2. Turn steering wheel so front wheels are pointed straight ahead.
3. Lower the implement, lock the parking brake and stop the engine.
4. Measure distance between tire beads (center) at front of tire and hub height.
5. Measure distance between tire beads at the rear of tire and hub height.

6. Front distance should be 2~8 mm less than rear distance. If not, adjust the tie rod length.

**ReADJUSTmeNT**

(1) Tie Rod Lock Nut

(2) Tie Rod

1. Loosen the lock nut and turn the turnbuckle to adjust the rod length until the proper toe-in measurement is obtained.
2. Check the toe-in value after the tie rod is adjusted.
3. Adjust it again if necessary.

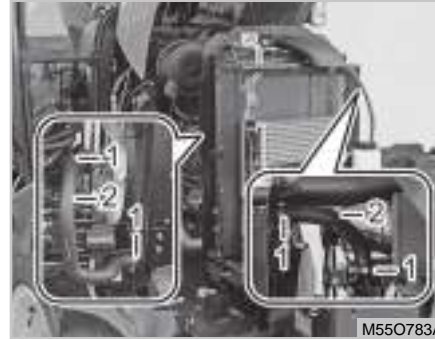
**CheCKING RADIATOR hOSe AND CLAmP (Z)**

(1) Clamp

(2) Hose

Check to ensure the radiator hoses are free from damage and are tightened properly every 200 hours or every 6 months, whichever comes first.

1. If the hose clamps are loose or water leaks from hose, tighten clamps securely.
2. If the radiator hoses are swollen, hardened, cracked, or otherwise damaged, you must replace the hoses. Failure to do so could lead to coolant loss and engine damage.

**PReCAUTION AT OverRheATING**

Take the following actions in the event the coolant temperature reaches the boiling point, what is called "Over-heating".

1. Stop the machine in a safe place and keep the engine idling.
2. After 5 minutes of unloaded idling, shut the engine down.
3. Keep yourself away from the tractor for another 10 minutes or until steam has stopped blowing out of the engine.
4. Make sure that there is not danger and repair the cause of the over-heating according to the manual's instruction.



## POWeR STeeRING LIne (AA)

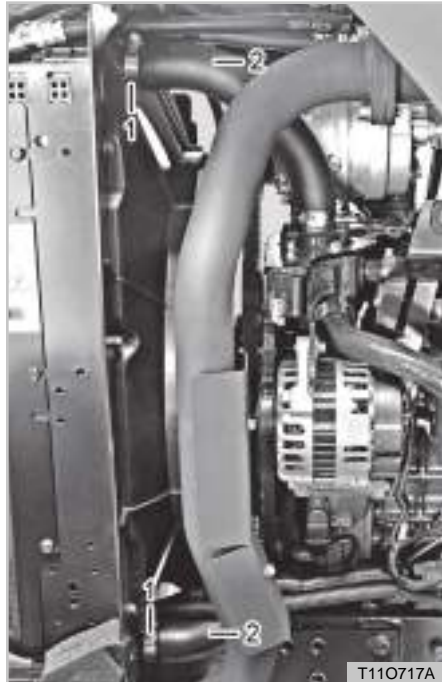

(1) Power Steering Oil Line (2) Connect

1. Check to see that all hydraulic lines and hose fittings are tight and undamaged.
2. If damage is found you should replace the hoses at once.

## AIR CONDITioNeR BeLT TeNSION (AB)

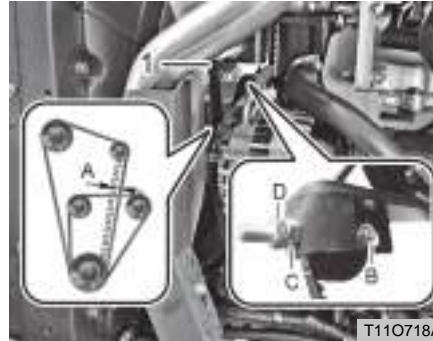

(1) Air Conditioner Belt  
 (A) Tension Amount (B) Mounting Nut  
 (C) Adjustment Nut (D) Lock Nut

1. Stop the engine and apply the parking brake.
2. Unscrew the nuts (B) and (D) and press the middle of the belt with force of 10 kg/f. Adjust the belt tension to the specification with the nut (C). Then, tighten the nuts (B) and (D).

### Belt deflection for proper fan belt tension (A)

0.39~0.47 in (10~12 mm)

3. Replace the damaged belt.

### ⚠ CAUTION

- Stop the engine before checking air conditioner belt.





## CLeANING AIR CONDITiONeR CONDENSER (AC)

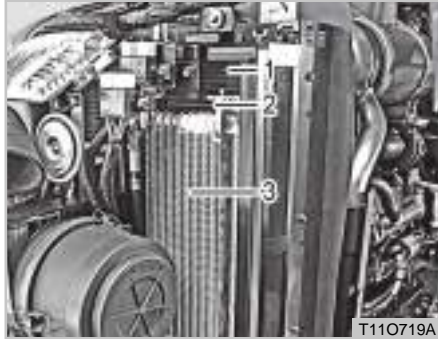

(1) Net (2) Condenser  
(3) Oil Cooler

1. Pull the hood lever on the right side forward to open the hood.
2. Undo the wing bolt and pull the grill to the right side to remove it. Remove the oil cooler as necessary to clean the condenser.

### CAUTION

- **Make sure to stop engine when checking. If cooler fan is blocked by dirt, clean with a soft brush or cloth using water.**

## ADJUSTING FRONT AXLe PivOT (AD)



(1) Adjusting Bolt (2) Lock Nut

If the front axle pivot pin adjustment is not correct, front wheel vibration can occur causing vibration in the steering wheel

### ADJUSTING PROCeDURE

Loosen the lock nut, tighten the adjusting screw all the way, and then loosen the screw by 1/6 turn. Retighten the lock nut.

## ADJUSTING eNGINE v ALve CLeARANCE (Ae)

Engine operation can be adversely effected by this adjustment. Therefore, contact your local **KIOTI** Dealer for this service.

## RePLACING AIR CLeANer FILTeR (AF)



(1) Filter (2) Cap  
(3) Evacuator Valve

If the air cleaner is not in good condition, the lifetime of the engine can be shortened, excessive soot can be produced, and the engine power can be deteriorated. Therefore, the filter should be inspected frequently. Its replacement interval can be changed according to driving conditions. Replace the filter according to the following procedure:

1. Open the hood and check the suction hose and air cleaner housing for damage.

2. Unscrew the air cleaner clip and remove the cover.
3. Clean the inside of the air cleaner housing by blowing compressed air through it.
4. Replace the filter and check the housing for damage.
5. Install the cover and fix it with the clip.

### NOTE

- When installing the cover, make sure that the dust collection valve is heading down.

### CAUTION

- **Use only a genuine filter. Use of a non-recommended filter can cause damage to the engine and sensor.**
- **make sure that no dust enters the system by installing the cover firmly.**
- **When removing the filter, be careful not to let foreign material enter the air inlet.**

## CheCKING AIR CONDITioNer hOSe (AG)

Check the linkage and condition of the air conditioner hose and pipe.

## CheCKING CAB CUSHION RUBBeR (Ah)

Check the condition of the cab cushion rubber.

**RePLACING AIR FILTeR (AI)**

(1) Bolt

(2) Filter

1. After loosening bolts from the left and right side of the cabin roof then separate the filter.

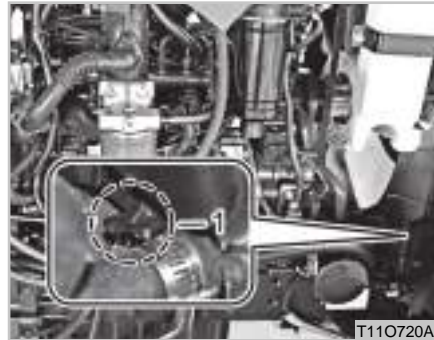
**FLUSh COOLING SYStEm AND ChANGING COOLANT (AJ)**

(1) Drain Cock

1. Stop the engine and let it cool.
2. To drain coolant, remove the drain plug from the radiator and turn the radiator cap to the 1<sup>st</sup> notch to release pressure in the radiator. Then, remove the cap completely.
3. After all coolant is drained, close the drain cock.
4. Fill with clean water and anti-freeze.
5. Install the radiator cap securely.

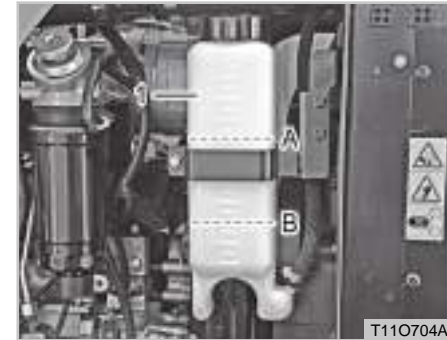

(1) Reservoir Tank

(A) FULL

(B) LOW

6. Add coolant to the reservoir tank to the "FULL" level.
7. Start and operate the engine for few minutes.
8. Stop engine and let cool.
9. Check coolant level of reservoir tank and radiator. Add coolant if necessary.

**Coolant capacity**

2.4 U.S. gal. (9.1 L)

**CAUTION**

To avoid accidents:

- Do not remove the radiator cap while the coolant is hot. You can be burned by hot steam. make sure to remove it after the coolant is cooled down enough.
- even though the coolant is cooled down, turn the cap to its first stop and then wait until it is depressurized before removing the cap completely.

**IMPORTANT**

- Do not start engine without coolant.
- Use clean, fresh water and anti-freeze to fill the radiator and reservoir tank.
- When the anti-freeze is mixed with water, the anti-freeze mixing ratio must be no less than 50% mixture of water and anti-freeze.
- Securely tighten radiator cap. If the cap is loose or improperly fitted, water may leak out and the engine could overheat.
- If the radiator cap has to be removed, follow the caution above and securely retighten the cap.
- If the coolant leaks, contact your local KIOTI Dealer.

**ANTI-FReeZe**

This tractor is filled with 50% of ethylene glycol at factory.

If the anti-freeze has been replaced by tap water later on, the coolant can freeze, leading to damage to the cylinder and radiator when the ambient temperature is below zero (32 °F).

Therefore, make sure to change water into anti-freeze before winter season comes.

When changing the anti-freeze with one of another type, flush the cooling system several times and contact a professional for the mixture ratio.

vol. % Anti-freeze	Freezing Point		Boiling Point*	
	°F	°C	°F	°C
40	-12	-24	222	106
50	-34	-37	226	108



- \* At 760 mmHg pressure (atmospheric). A higher boiling point is obtained by using a radiator pressure cap.

### NOTE

- The temperatures shown on the left are industry standards that necessitate a minimum glycol content in the concentrated anti-freeze.
- When the coolant level drops due to evaporation, add water only. In case of leakage, add anti-freeze and water in the specified mixing ratio.
- Anti-freeze absorbs moisture. Keep unused anti-freeze in a tightly sealed container.
- Do not use radiator cleaning agents when anti-freeze has been added to the cooling water. (Anti-freeze contains an anti-corrosive agent, which will react with the radiator cleaning agent forming sludge which will affect the engine parts.)

## DRAINING WATER FROM CLUTCH HOUSING (AL)



(1) Drain Bolt

### ImPORTANT

- If you forget to install the plug, the clutch can be damaged. Foreign material can enter through the open drain hole.

1. There is a plug under the clutch housing.
2. Drain the water completely and install the plug. Drain the water into a container and dispose of it in a proper manner for environment protection.
3. Make sure to install the plug and not to damage the clutch severely.
4. Make sure to drain water after working in a paddy field and watery field.

## CheCKING AND RePLACING WIPeR (AP) INSPeCTION



(1) Wiper

Check the operation and wear of the wiper blades frequently. To replace the wiper blade, press the wiper fixing lever to separate it and then pull it away.

To remove the wiper arm, lift the cap of the wiper arm, remove the nut, and set the wiper arm upright. Then, hold the arm head and shake it left and right to remove the wiper arm from the drive spindle. Disconnect the washer fluid hose and then install a new wiper arm to its position by aligning it to the proper angle.

## RePLACeMeNT

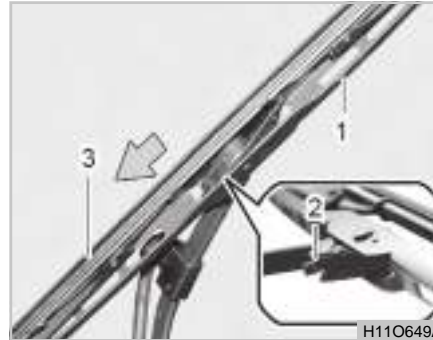

(1) Wiper Arm      (2) Wiper Fixing Lever  
(3) Wiper Blade

1. Set the wiper upright to replace the wiper blade.
2. Hold the blade with one hand and press the blade fixing lever with the other hand to separate the blade from the fixing part.



(1) Wiper Blade

3. Lower the blade and pull out the blade by moving it in the shape of "U" (arrow direction in the figure).

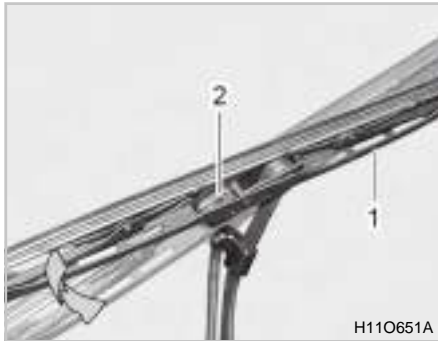

(1) Wiper Arm      (2) Fixing Lever

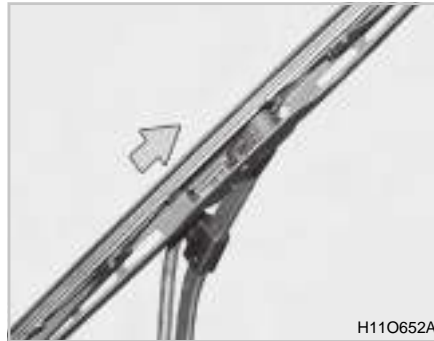

4. Set a new wiper blade horizontal so that the fixing lever is facing down. Align the wiper arm with the fixing lever slot and lower the blade.

5. Lift the wiper blade to its end and install it so that the fixing lever is engaged with the wiper arm. (A clicking sound is heard)

### CAUTION

- When the wiper blade is separated, the wiper arm should not contact the windshield or rear glass. The glass can be damaged.

### CAUTION

- When wiping the windshield, set the wiper blade upright, spray water onto the glass with a hose, and wipe the glass with clean cloth.
- If the wiper blade is frozen to the glass in a cold weather or there is no washer fluid, never operate the wiper.
- In order to prevent damage of the wiper blade, never use synthetic detergent, thinner or solvent on the windshield.

## RePLACING FUSE (AN)



(1) Fuse Box

Fuses protect the tractor electrical system from potential damage.

A blown fuse indicates that there is an overload or short somewhere in the electrical system. If a fuse is blown, find and remove the fault.

Then replace it with a new fuse with the same capacity.

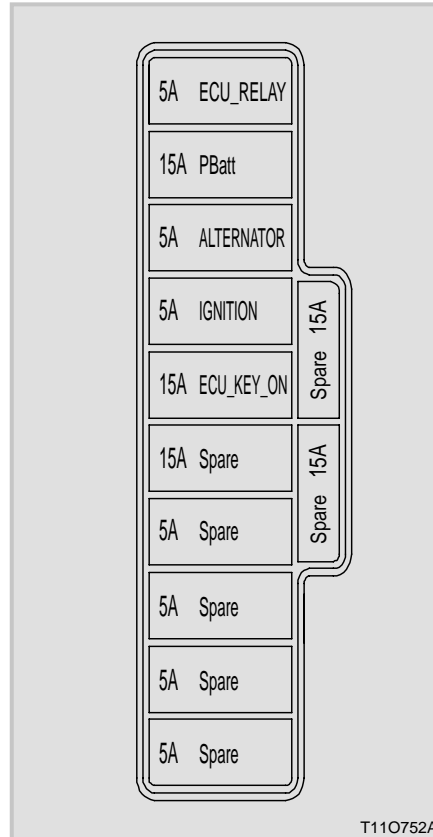

T110752A

### ⚠ WARNING

- *Never use a fuse with the capacity higher than specified on the fuse box cover.*
- *If using a faulty fuse, steel wire, or foil, the electrical device can be damaged or even catch a fire.*

### 📖 NOTe

- If the replaced fuse is blown, it is probable that the wiring system is faulty. In this case, contact your local **KIOTI** Dealer.
- If the fusible link, relay or other electrical component is faulty, contact your local **KIOTI** Dealer.





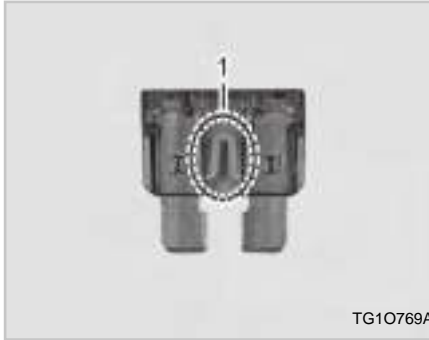
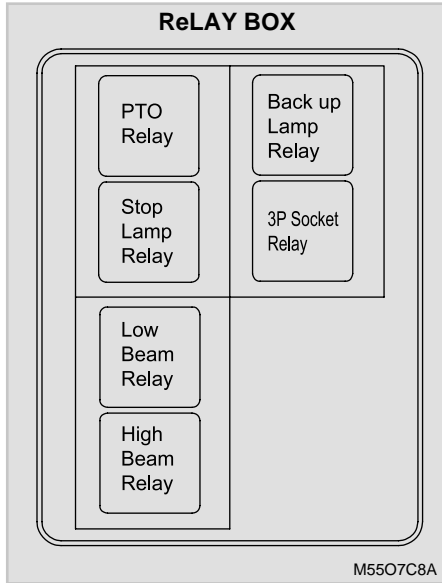

*(1) Normal Fuse*

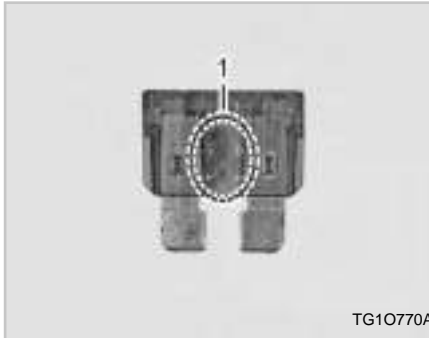

*(1) Blown Fuse*

There are marks for the fuse capacity and location on the cover of the fuse panel. Replace the fuse according to the following procedure:

1. Turn the key switch to the "OFF" position and turn off all the electrical devices.
2. Open the fuse box cover and check the fuse in question using fuse tongs.



### SLOW BLOW FUSE (AP)



H110655A

- 3. If the fuse is blown, replace it with a new fuse with the same capacity. Make sure it is firmly installed.
- 4. Install the fuse box cover.

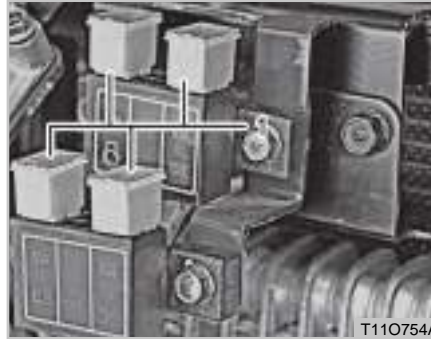

T110754A

(1) Slow Blow Fuse

The slow blow fuse is to protect the electric wiring. If it is blown, find and repair the cause and replace it with a new genuine **KIOTI** part.

Slow Blow Fuse
60A

### mAIN FUSE (AS)

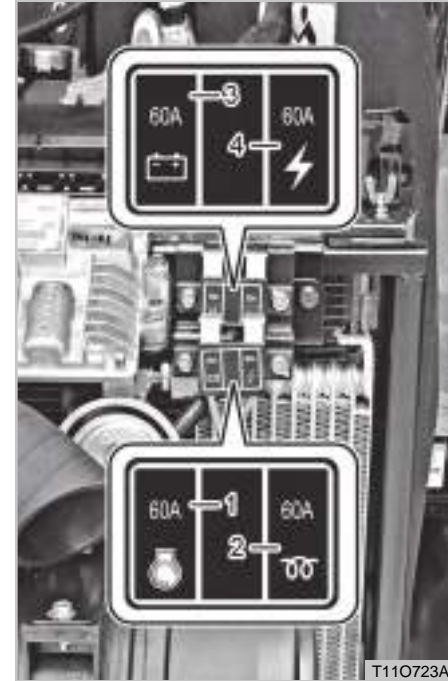

T110723A

- (1) Ignition Power Fuse
- (2) Preheat Power Fuse
- (3) Main Power Fuse
- (4) Charge Power Fuse

The main fuse is to protect electric

devices and wirings. If the ignition, preheat, charge or main function is faulty, find and remove the fault and replace the fuse with a new one.

<b>main Fuse</b>
60A

**⊕ ImPORTANT**

- **Using a non-approved slow-blow fuse can damage electrical systems in the tractor severely.**
- **Refer to the chapter "Troubleshooting" in this manual or contact your local KIOTI Dealer for specific information dealing with electrical problems.**

**RePLACING BULB (AQ)**

The bulb and capacity used in this tractor are listed in the below table.

No.	Bulb	Capacity	
1	Head Lamp	55W/55W	
2	Position Lamp (Front)	5W	
3	Stop/position Lamp (Rear)	21W/5W	
4	Turn Signal Lamp	21W	
5	Work Lamp	35W	
6	Cluster Indicator	Charging Warning Light	3W
		Others	1.4W
7	Backup Lamp	21W	

**heAD LAmP**



- (1) Handle  
(A) Pull (B) Open

1. Turn the key switch to the "OFF" position and open the hood.

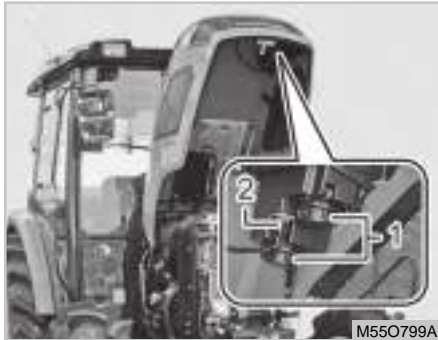

(1) Cap

(2) Connector

2. Remove the cap.
3. Press and turn the socket counterclockwise to remove the bulb. If the bulb is blown, replace it with a new bulb with the same capacity.

**⚠ WARNING**

- *If using a bulb other than the specified one, the lamp can be damaged and the tractor can even catch fire.*
- *make sure to use bulbs with the specified capacity.*

**⚠ CAUTION**

- **make sure to use a KIOTI genuine bulb. Using a non-recommended bulb can cause a fire.**
- **The headlamps can temporarily be fogged due to rain or car wash. This is because of the temperature difference between the inside and outside of the lamp, which is normal.**

**WORK LAMP (FRT/RR)**

The work lamp uses a halogen bulb. Do not touch the illuminating part of the halogen bulb.

The bulb life can be shortened by finger prints, dust and moisture, or the bulb even can be broken. Clean it with soft cloth.

Be careful of the following when replacing the halogen bulb:

- Replace the bulb after it is cooled down.
- Do not touch the glass of the bulb.
- Handle the bulb with care and be careful not to scratch or rub it.
- Do not let the bulb contact with liquid when it is illuminated.
- Wear protective glasses when replacing the bulb.



(1) Work Lamp Glass Case

1. Turn the key switch to the "OFF" position and unscrew the screw

from the mounting hole with a cross-head screwdriver to separate the front glass case.



(1) Work Lamp Bulb

2. Unscrew the ground wire screw, disconnect the connector, and turn the bulb counterclockwise to remove it. Then, install a new bulb with the same capacity.

### CABIN LAMP



(1) Cabin Lamp Bulb

1. Fit a flat-bladed screwdriver into the edge of the cabin lamp and pry off the room lamp cover.
2. Remove the cabin lamp bulb by pulling it up. Install a new bulb.



## TURN SIGNAL LAMP (ReAR)



(1) Turn Signal Lamp (RR)

1. The turn signal lamp(rear) is installed on the rear fender.



(1) Protective Cover  
(2) Mounting Bolt

2. Unscrew the mounting bolts from the inside of the rear fender.



(1) Turn Signal Lamp (RR) Bulb

3. Remove the bulb by turning its socket counterclockwise. Install a new bulb.

### TURN SIGNAL LAMP (FRONT)

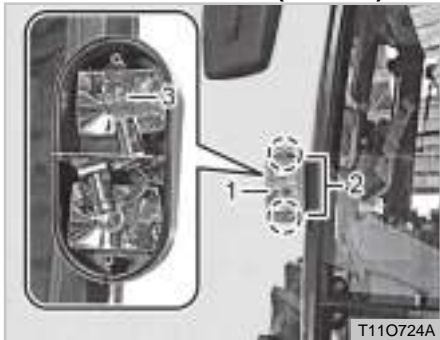

- (1) Turn Signal Lamp (FRT)
- (2) Mounting Bolt
- (3) Turn Signal Lamp (FRT) Bulb

1. Remove the cap and unscrew the mounting bolts to remove the front turn signal lamp assembly.
2. Turn the bulb body counterclockwise to remove it.
3. Remove the bulb by pressing it down lightly and install a new bulb. Fit the socket to the grooves and turn it clockwise.

### LICeNSe PLATe LAMP

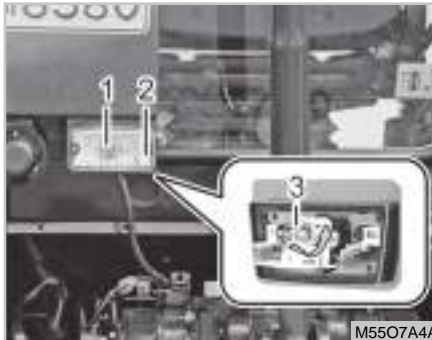

- (1) Licence Plate Lamp
- (2) Mounting Bolt
- (3) Licence Plate Lamp Bulb

1. Remove the cover and unscrew the bolt. Then, turn the bulb while pressing it down lightly to remove it. Install a new bulb.

### ⚠ CAUTION

- Do not touch the bulb if it is still illuminated or right after it is turned off. You can be burned by the hot bulb.
- For some bulbs which require delicate handling or work process, contact your local KIOTI Dealer.
- Do not touch the illuminating glass part of the halogen bulb. The bulb life can be shortened by finger prints, dust and moisture, or the bulb even can be broken. Clean it with soft cloth.
- The halogen bulb contains compressed gas, so it can explode if dropping or scratching it. Therefore, never use a bulb if it is scratched or was dropped.



 **CAUTION**

- **When separating the cover by prying it off with a screwdriver, be careful not to damage it.**
- **Before replacing a bulb, make sure to put the key switch and the switch for the corresponding bulb to the "OFF" position.**
- **Install a new bulb with the same capacity after removing the installed bulb.**

**CheCKING ReFRIGeRANT (AR)**

If the refrigerant is insufficient, the performance of the air conditioner is deteriorated. Also, charging the air conditioner with excessive refrigerant affects its performance. Therefore, have the system checked by your local **KIOTI Dealer** if a malfunction is found.

 **CAUTION**

- **Park tractor on a flat place and chock the wheels.**
- **Put forward/backward lever, main shift lever and PTO lever in neutral.**

 **WARNING**

- ***Only qualified service personnel should service the air conditioner as its refrigerant is under high pressure. An injury can occur.***

**AIR CONDITioNeR mAINTe-NANCe (AS)**

Make sure to follow the instructions below to keep the air conditioner in the best condition:

**1. Operation in winter season:**

During the winter time, run the air conditioner once or twice every month to prevent refrigerant leakage and corrosion in the air conditioner system and to facilitate oil circulation in the compressor in order to prevent malfunction.

The A/C does not operate when the air temperature is below 2°C. Therefore, warm the inside air by operating the heater in order to be able to operate the A/C.

**2. Air conditioner condenser care:**

If there is foreign material in the A/C condenser and engine radiator, their cooling performance may be deteriorated. Therefore, always keep them clean for their optimal cooling performance. When cleaning the core of the condenser, use a soft brush and water. Carefully

clean the condenser so as not to bend it.

### 3. Operation in summer season:

Make sure to check the tension of the A/C belt before using the A/C frequently.

#### CAUTION

- The A/C system is charged with new refrigerant that does not destroy the ozone layer. Be careful when servicing the A/C system.
- Do not use unspecified refrigerant and compressor oil, or the air conditioner system could be seriously damaged.
- The performance of the A/C becomes poor when the refrigerant is insufficient. However, charging the air conditioner with excessive refrigerant also affects its performance negatively. Therefore, have the system checked by a KIOTI Dealer if malfunction is found.

## SPeCIFICATIONS FOR A/C Re- FRIGeRANT AND LUBRICANT

Item	New refrigerant	Compressor oil
Type	HFC-134a	UCON488
Charging amount	1.65 lbs. (0.75 kg)	0.07 U.S.gal (265cc)

#### WARNING

- *have the air conditioner serviced by qualified service personnel. If it is serviced by an unqualified person, he/she can be injured by the refrigerant under high pressure.*

## TURBOChARGeR (AU)



T110758A

(1) Turbocharger

#### NOTe

- It may rust on the turbo-charger or exhaust manifold after this coating is deteriorated or burned due to heat in a short time of engine run hour. But this is normal symptom and there is no problem on engine operations.
- When the coating is burning away, it can create some fumes, but it is also normal .



# STORAGe AND DISPOSAL

**TRACTOR STORAGe ..... 8-2**

    DAILY STORAGE .....8-2

    LONG-TERM STORAGE.....8-2

    USING TRACTOR AFTER STORAGE .....8-4

**USAGe AND DISPOSAL..... 8-5**

8

8



## TRACTOR STORAGE DAILY STORAGE

1. Keep the tractor clean when it is stored. Make sure to wash it after work.
2. Store it indoors if possible. If it should be kept outside, cover it.

### WARNING

- *When operating the tractor in an enclosed area, ventilate the area to release exhaust gas to the outside. The exhaust gas is colorless and not visible, but is harmful.*

3. Remove the battery from the tractor in winter and store it indoors.
4. Add anti-freeze to the tractor in winter season in order to prevent the radiator from freezing.
5. Remove the ignition key and store it separately.

## LONG-TeRm STORAGE

Follow the instructions below if the tractor is not to be used for a long period of time. This is to operate the tractor again with minimum preparation after long-term storage. Repeat this procedure if the tractor hasn't been used for one year.

### ImPORTANT

- **If the tractor is not used for an extended period of time, follow the instructions below to prevent corrosion and performance deterioration of the tractor while it is stored.**

1. Check the bolts and nuts for looseness, and tighten if necessary.
2. Apply grease to tractor areas where bare metal will rust also to pivot areas.
3. Detach the weights from the tractor body.
4. Inflate the tires to a pressure a little higher than usual.

5. Change the engine oil and run the engine to circulate oil throughout the engine parts for about 5 minutes.
6. With all implements lowered to the ground, coat any exposed area such as hydraulic cylinder piston rods with grease.



(1) Clutch Pedal

(2) Locking Pin

7. Use the clutch locking pin to keep the clutch disengaged. If the clutch is left engaged for a long period of time, the clutch cover may rust, making clutch disengagement impossible at the next operation.
8. Remove the battery from the tractor. Store the battery following the battery storage procedures. (See section "Battery" in the chapter 7 "Maintenance")

9. Keep the tractor in a dry place where the tractor is sheltered from rain. Cover the tractor.
10. Store the tractor in a place out of direct sunlight and heat. If it is unavoidable to keep it outside, cover it with a waterproof cover. Lift the tractor with a jack and place blocks under its front and rear axles. Also, keep direct sunlight and heat away from the tires.
11. Clean the engine components as well as the tractor.
12. Add grease to all the grease fitting.
13. Worn or damaged parts should be replaced.
14. If a loader or implement is attached, lower it onto level ground.
15. Apply grease to the exposed section of the cylinder rod.
16. Flush the cooling system and drain water from it. Also, add antifreeze as well as water.

17. Replace all oil and filters.
18. Replace the air cleaner filter.
19. Chock the frame in order to remove the weight from the tires.
20. Set all control systems neutral.
21. Plug any open exhaust pipes.
22. Attach a tag onto the tractor to inform the storage condition of the tractor.
23. For the tractor equipped with the air conditioning system, start its engine once a month to run air conditioning system.

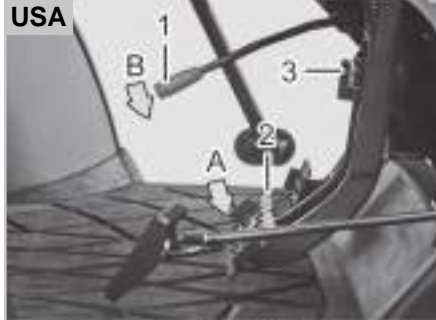

(1) Parking Brake Lever (2) Brake Pedal  
 (3) Connecting Hook  
 (A) Depress (B) Lower

24. Interlock the brake pedals and apply the parking brake.

**CAUTION**

To avoid injury:

- Never clean the tractor body while the engine is running.
- Never run the engine in an enclosed area without proper ventilation system in order to prevent poisoning by exhaust gas.
- When storing the tractor, remove the key from the switch and store it separately in order to prevent an unauthorized person from operating the tractor and being injured.
- Cover the tractor after the muffler and the engine have cooled down.
- If the battery is not to be removed, disconnect its negative terminal at least. The wiring can be gnawed by rodents, leading to a fire.

**USING TRACTOR AFTER STORAGE**

1. Check the tire air pressure and inflate the tires if they are low.
2. Install a fully charged battery.
3. Check the fan belt tension.
4. Check all fluid levels.  
 (Engine oil, transmission/hydraulic oil, engine coolant and any attached implements)
5. Remove grease from the exposed cylinder rod.
6. Apply grease to the lubrication points.
7. Depress the clutch pedal and undo the latch hook.
8. Get onto the tractor and start the engine.
9. Check if the instrument panel and all parts operate correctly while running the engine for a few minutes.
10. Drive the tractor outside and check if it is operating properly. Park the tractor outside and idle engine for at least 5 minutes. Stop the engine and visually inspect the tractor. Check if there is leakage.



## USAGE AND DISPOSAL

11. Start the engine, release the parking brake, and check the brake condition while driving forward. Adjust the brake pedals if necessary.
12. Stop the engine and check for leaks. Repair any part as required.

### CAUTION

- **Unless the battery is removed from the vehicle, make sure to disconnect the negative battery cable. Cables can be damaged by animals, leading to a fire.**

In order to protect the environment, use and dispose of the tractor keeping the following in mind:

1. When changing the oil or coolant by yourself, be careful not to spill it. Dispose of used oil and coolant properly according to the applicable regulations.
2. Never leave or discard a old tractor or implement without discretion on your own, but contact your local **KIOTI** Dealer to dispose of it according to the regulations.
3. Avoid working under high load as it may can cause excessive exhaust gas, which is harmful to the environment.



memO







# *TROUBLEShOOTING*

**eNGINE TROUBLEShOOTING ..... 9-2**  
**TRACTOR TROUBLEShOOTING ..... 9-4**

# 9

9

This troubleshooting chart summarizes simple service items for users who are familiar with mechanical systems. For more detailed service items, contact your local **KIOTI** Dealer.

### eNGINE TROUBLEShOOTING

CAUSE		COUNTERmeASUReS
1. When engine is difficult to start	<ul style="list-style-type: none"> <li>Fuel is thick and doesn't flow.</li> </ul>	<ul style="list-style-type: none"> <li>Check the fuel tank and fuel filter.</li> <li>Remove water, dirt and other impurities.</li> <li>All fuel will be filtered by the filter, if there should be water of other foreign material on the filter, replace the filter.</li> </ul>
	<ul style="list-style-type: none"> <li>Air or water mixed in fuel system.</li> </ul>	<ul style="list-style-type: none"> <li>If air is in the fuel filter or injection lines, the fuel pump will not work properly.</li> <li>To attain proper fuel injection pressure, check carefully for loosened fuel cap nut, etc.</li> <li>Loosen air vent screw over fuel filter and fuel injection pump to eliminate all the air in the fuel system.</li> </ul>
	<ul style="list-style-type: none"> <li>Thick carbon deposits on orifice of injection nozzle.</li> </ul>	<ul style="list-style-type: none"> <li>This is caused when water or dirt is mixed in the fuel. Clean the nozzle injection piece, being careful not to damage the orifice.</li> <li>Check to see if nozzle is working properly or not, if not, install a new nozzle.</li> </ul>
	<ul style="list-style-type: none"> <li>Valve clearance is wrong</li> </ul>	<ul style="list-style-type: none"> <li>Contact <b>KIOTI</b> dealer.</li> </ul>
	<ul style="list-style-type: none"> <li>Engine oil become thick in cold weather and engine cranks slow.</li> </ul>	<ul style="list-style-type: none"> <li>Change grade of oil according to the weather (temperature).</li> </ul>



CAUSE	COUNTERMeASURES						
1. When engine is difficult to start	<ul style="list-style-type: none"> <li>Start motor does not rotate when key switch is turned</li> </ul>	<ul style="list-style-type: none"> <li>Depress the clutch pedal unless depressed (Manual type).</li> </ul>					
		<ul style="list-style-type: none"> <li>Put the PTO switch to the "OFF" position.</li> </ul>					
		<ul style="list-style-type: none"> <li>If the switch or start motor is faulty, have it repaired in a workshop.</li> </ul>					
		<ul style="list-style-type: none"> <li>If any terminal is loose or corroded, clean or fix it firmly.</li> </ul>					
2. When output is insufficient	<ul style="list-style-type: none"> <li>Check ENGINE lamp ON</li> </ul>	<ul style="list-style-type: none"> <li>Check if the check ENGINE lamp is turned on. If it is, contact your dealer.</li> </ul>					
	<ul style="list-style-type: none"> <li>Valve out of adjustment</li> </ul>	<ul style="list-style-type: none"> <li>Contact <b>KIOTI</b> dealer.</li> </ul>					
	<ul style="list-style-type: none"> <li>Air cleaner is dirty</li> </ul>	<ul style="list-style-type: none"> <li>Clean or replace the element at every 100 to 200 hours of operation.</li> </ul>					
	<ul style="list-style-type: none"> <li>Fuel injection pressure is wrong</li> </ul>	<ul style="list-style-type: none"> <li>Contact <b>KIOTI</b> dealer.</li> </ul>					
3. When color of exhaust is especially bad	<ul style="list-style-type: none"> <li>Fuel is of extremely poor quality</li> </ul>	<ul style="list-style-type: none"> <li>Check if the check ENGINE lamp is turned on. If it is, contact your dealer.</li> </ul>					
		<ul style="list-style-type: none"> <li>Nozzle is bad</li> </ul>	<ul style="list-style-type: none"> <li>Select good quality fuel.           <table border="0" data-bbox="946 886 1387 965"> <tr> <td>Temperature</td> <td>Fuel type</td> </tr> <tr> <td>- Above 14°F (-10°C)</td> <td>NO.2 Diesel</td> </tr> <tr> <td>- Below 14°F (-10°C)</td> <td>NO.1 Diesel</td> </tr> </table> </li> <li>If necessary, replace with new nozzle.</li> </ul>	Temperature	Fuel type	- Above 14°F (-10°C)	NO.2 Diesel
Temperature	Fuel type						
- Above 14°F (-10°C)	NO.2 Diesel						
- Below 14°F (-10°C)	NO.1 Diesel						

※ If you do not find the cause of trouble, consult your **KIOTI** dealer for assistance.



## TRACTOR TROUBLESHOOTING

CAUSE		COUNTERMeASUReS
1. When tractor does not move while engine is running	• Shift lever is in neutral position	• Check the shift levers.
	• Parking brake is applied	• Release the parking brake.
2. Clutch is not operating properly	• Clutch slips (idles)	• Faulty clutch pedal position sensor, Contact <b>KIOTI</b> dealer.
		• Worn hydraulic clutch, Contact <b>KIOTI</b> dealer.
		• Poor calibration to engage clutch. Contact <b>KIOTI</b> dealer and calibrate engaging time.
	• Clutch cannot be disengaged	• Poor calibration to engage clutch. Contact <b>KIOTI</b> dealer and calibrate engaging time. • Faulty hydraulic valve or hydraulic system. Contact <b>KIOTI</b> dealer
3. Brake is not operating properly	• Brake does not operate or only one brake pedal operates	• The brake pedal play is excessive. Adjust the play. • The brake lining is worn or stuck. Have it replaced in a workshop.
	• Brake pedal does not return properly	• The brake return spring is damaged. Replace it. • Grease is insufficient on each mating surface. Remove rust and apply grease.
		4. Steering wheel is not operating properly
• Steering wheel is heavy or vibrates	• The steering wheel shaft is worn. Have it repaired in a workshop. Metal parts are worn. Have them repaired in a workshop. Each connection has play. Tighten the connection again.	
• Steering wheel play is excessive		





CAUSE		COUNTERMeASURES
5. Hydraulic system is faulty	<ul style="list-style-type: none"> <li>Oil is leaked from pipe or hose</li> </ul>	<ul style="list-style-type: none"> <li>The pipe clamp is loose. Re-tighten it.</li> </ul>
	<ul style="list-style-type: none"> <li>3-point hitch cannot be lowered</li> </ul>	<ul style="list-style-type: none"> <li>The pipe is cracked. Have it repaired in a workshop.</li> <li>3-point hitch safety lock function activated, one touch button pressed</li> <li>The valve and cylinder are damaged. Contact <b>KIOTI</b> dealer.</li> </ul>
	<ul style="list-style-type: none"> <li>3-point hitch cannot be lifted</li> </ul>	<ul style="list-style-type: none"> <li>The transmission fluid is insufficient. Add it to the specified level.</li> <li>There is air in the intake pipe. Bleed the pipe.</li> <li>The oil filter is clogged. Replace it.</li> <li>The hydraulic filter, valve and cylinder are malfunctioning. Contact <b>KIOTI</b> dealer.</li> </ul>
	<ul style="list-style-type: none"> <li>3-point hitch hops itself</li> </ul>	<ul style="list-style-type: none"> <li>Each sensor malfunctioning, Contact <b>KIOTI</b> dealer.</li> <li>Select the highest top link hole.</li> </ul>
6. Electric system is faulty	<ul style="list-style-type: none"> <li>Headlamps cannot be turned on or are dim.</li> </ul>	<ul style="list-style-type: none"> <li>The fuse is blown. Check the wiring and replace the fuse.</li> </ul>
		<ul style="list-style-type: none"> <li>The bulb is blown. Replace it</li> </ul>
		<ul style="list-style-type: none"> <li>The ground and terminal wirings are poorly contacted. Check and clean them.</li> </ul>
		<ul style="list-style-type: none"> <li>The battery electrolyte level is low. Charge the battery.</li> </ul>



CAUSE		COUNTeRmeASUReS
6. Electric system is faulty	• Battery cannot be charged	• Check the battery and alternator.
	• Horn does not sound	• The horn switch is faulty. Replace or see <b>KIOTI</b> dealer.
		• The wiring is faulty. Replace or See <b>KIOTI</b> dealer.
	• Turn signal lamps do not blink	• The horn is damaged. Repair or replace it.
• The bulb is blown. Replace it.		
• Work lamps do not come on	• The blinking device is faulty. Repair or replace it.	
	• The ground and terminal wirings are poorly contacted. Check and clean them.	
7. Heater/air conditioner motor is faulty	• Fan speed is slow or no air is blown out	• The fan speed control switch and motor are faulty. Repair or replace them.
		• The air suction filter is clogged.
		• The wiring is short circuited. Check and repair it.
	• Fan speed cannot be controlled	• Replace the fan speed control switch.
		• The motor is faulty. Repair or replace it.
8. A/C performance is poor	• Abnormal noise occurs	• The internal parts are not sufficiently lubricated. Add lubricant.





CAUSE		COUNTeRmeASUREs
8. A/C performance is poor	• Abnormal noise occurs	• The belt is loose. Adjust the belt tension.
		• The bracket is loose. Tighten its bolts again.
		• Inner and outer components are damaged. Check and repair them
	• Refrigerant and oil are leaking	• The sealing washer is broken. Replace it.
		• The tightening bolt is loose. Tighten it
	• High temperature and low pressure occur	• The refrigerant is insufficient. See <b>KIOTI</b> dealer.
		• The compressor is faulty. Repair or replace it.
	• Compressor clutch does not operate	• The wiring is faulty. Check and replace it.
		• The clutch clearance is excessive. Adjust it.
		• The voltage is low. Replace the battery.
		• The internal part is malfunctioning. Replace it.
		• Insufficient refrigerant. Add refrigerant.
• Clutch slips	• The voltage is low. Replace the battery.	
	• The clutch disc is contaminated. Clean it.	
	• The internal part is defective. Repair and clean it.	

※ If you do not find the cause of trouble, consult your dealer for assistance.



memO







*INDeX*

**INDeX..... 10-2**

**10**

**10**

**NUmBeRICAL**

3-POINT HITCH CONTROL SYSTEM .....5-21  
 3-POINT HITCH IMPLEMENT AND LOADER OPERATION...6-1  
 4WD INDICATOR .....4-22  
 4WD SWITCH .....4-10  
 7-PIN POWER OUTPUT SOCKET .....4-57

**A**

A/C REFRIGERANT AMOUNT INSPECTION .....4-55  
 A/C REFRIGERANT CAPACITY .....4-55  
 ACCESSORY .....4-52  
 ACTIVATION (UPPER BUTTON) .....4-13  
 ADDITIONAL FRONT WEIGHT .....4-64  
 ADDITIONAL LIQUID TYPE WEIGHT .....4-66  
 ADDITIONAL REAR WEIGHT (IF EQUIPPED).....4-65  
 ADDITIONAL WEIGHT.....4-65  
 ADJUSTING PROCEDURE .....7-28  
 ADJUSTING PROCEDURE .....7-31  
 ADJUSTING BRAKE PEDAL (O) .....7-18  
 ADJUSTING CLUTCH PEDAL (R) .....7-20  
 ADJUSTING ENGINE VALVE CLEARANCE (AE) .....7-31  
 ADJUSTING FAN BELT TENSION (V).....7-25  
 ADJUSTING FRONT AXLE PIVOT (AD).....7-31  
 ADJUSTING TOE-IN (Y) .....7-28

ADJUSTMENT OF LIFT ROD .....6-5  
 ADJUSTMENT OF STABILIZER .....6-7  
 ADJUSTMENT OF TOP LINK .....6-6  
 AIR CONDITIONER BELT TENSION (AB).....7-30  
 AIR CONDITIONER MAINTENANCE (AS).....7-47  
 AIR CONDITIONER SWITCH .....4-54  
 AIR FILTER WARNING LAMP .....4-21  
 ANTENNA.....4-51  
 ANTI-FREEZE .....7-34

**B**

BATTERY (W).....7-26  
 BATTERY CHARGING LAMP .....4-19  
 BELTS AND RUBBER PARTS .....2-5  
 BLEEDING FUEL LINES (T2) .....7-23  
 BRAKE (ONE SIDE) LAMP .....4-26  
 BRAKE PEDAL.....4-35

**C**

CABIN LAMP .....7-44  
 CABIN LAMP .....4-51  
 CABIN SYSTEM.....4-45  
 CALIBRATION SWITCH.....4-15  
 CAUTIONS FOR DECAL MAINTENANCE .....1-27



CHANGING ENGINE OIL AND REPLACING FILTER (L) .7-13  
 CHANGING FRONT AXLE CASE OIL (N) .....7-17  
 CHARGING .....7-27  
 CHECKING AIR CONDITIONER HOSE (AG).....7-32  
 CHECKING AND ADDING FUEL (C) .....7-8  
 CHECKING AND REPLACING WIPER (AP) .....7-36  
 CHECKING BRAKE AND CLUTCH PEDALS (H) .....7-12  
 CHECKING CAB CUSHION RUBBER (AH) .....7-32  
 CHECKING COOLANT LEVEL (F).....7-11  
 CHECKING ENGINE OIL LEVEL (E) .....7-10  
 CHECKING FUEL LINES (U) .....7-24  
 CHECKING GAUGES, METER AND EASY CHECKER (I)7-13  
 CHECKING HEAD LIGHT, HAZARD LIGHT ETC. (J).....7-13  
 CHECKING INTAKE AIR LINE (X) .....7-28  
 CHECKING RADIATOR HOSE AND CLAMP (Z).....7-29  
 CHECKING REFRIGERANT (AR) .....7-47  
 CHECKING SEAT BELT AND CABIN (K).....7-13  
 CHECKING TRANSMISSION FLUID LEVEL (D).....7-9  
 CHECKING WARNING LAMPS .....5-7  
 CHECKING WHEEL BOLT/NUT TORQUE (Q).....7-20  
 CIGARETTE LIGHTER .....4-51  
 CLEANING AIR CONDITIONER CONDENSER (AC).....7-31  
 CLEANING GRILL, RADIATOR SCREEN (G) .....7-12  
 CLUTCH PEDAL .....4-34

CLUTCH PEDAL ENGAGEMENT CONTROL BUTTON...4-14  
 COMBINATION SWITCH .....4-8  
 COMPONENTS FOR ADDITIONAL FRONT WEIGHT .....4-65  
 CONNECTING AND DISCONNECTING IMPLEMENT .....5-27  
 CONNECTION .....5-27  
 COOLANT TEMPERATURE WARNING LAMP .....4-24  
 CRUISE PTO WARNING LAMP .....4-26  
 CUP HOLDER AND STORAGE .....4-51  
 CUSHION STRENGTH ADJUSTMENT .....4-38

**D**

DAILY CHECK CHART.....7-3  
 DAILY STORAGE .....8-2  
 DEACTIVATION (LOWER BUTTON) .....4-13  
 DECAL MOUNTING LOCATION (CABIN).....1-20  
 DECAL MOUNTING LOCATION (ROPS) .....1-22  
 DECALS .....1-24  
 DESCRIPTION OF OPERATING SYSTEM .....4-1  
 DIFFERENTIAL LOCK PEDAL.....4-38  
 DIFFERENTIAL LOCK WARNING LAMP .....4-21  
 DIRECTION FOR STORAGE .....7-27  
 DISCONNECTION .....5-27  
 DISMOUNTING THE IMPLEMENT .....6-7  
 DOUBLE ACTING LEVER.....5-25



**D**

DOUBLE ACTING LEVER.....4-43  
 DOUBLE ACTING VALVE .....5-24  
 DRAFT CONTROL .....5-23  
 DRAFT CONTROL LEVER .....4-42  
 DRAINING WATER FROM CLUTCH HOUSING (AL).....7-35  
 DRAW BAR AND TRAILER.....6-7  
 DRIVING ON DOWNHILL .....6-13  
 DRIVING ON DOWNHILL .....6-13  
 DRIVING ON SLOPES.....5-16  
 DRIVING ON SLOPES.....6-13  
 DRIVING ON UPHILL .....6-13  
 DRIVING ON UPHILL .....6-13

**e**

ENGINE CHECK WARNING LAMP .....4-25  
 ENGINE COOLANT TEMPERATURE GAUGE.....4-18  
 ENGINE OIL PRESSURE WARNING LAMP .....4-20  
 ENGINE SERIAL NUMBER .....2-2  
 ENGINE TROUBLESHOOTING.....9-2  
 ENTRANCE.....4-47  
 ESSENTIAL REPLACEMENT PARTS .....2-4  
 EVACUATOR VALVE.....7-22  
 EXTERIOR DEVICES .....4-47

EXTERIOR VIEW (CABIN).....4-3  
 EXTERIOR VIEW (ROPS) .....4-4  
 EXTERNAL DIMENSIONS .....3-2

**F**

FAN SPEED CONTROL DIAL.....4-53  
 FILTERS .....2-4  
 FIXATION POINTS FOR FRONT END LOADER .....6-12  
 FLUSH COOLING SYSTEM AND CHANGING COOLANT (AJ) ..7-33  
 FOOT THROTTLE .....4-37  
 FORWARD INDICATOR .....4-22  
 FRONT AND REAR WHEEL BOLT AND NUT TORQUE ..4-63  
 FRONT/REAR WHEEL INSTALLATION PATTERN .....4-63  
 FRONT/REAR TIRE TREAD [RX6020(C/C-P)].....4-60  
 FRONT/REAR TIRE TREAD [RX6620(C/C-P)].....4-61  
 FRONT/REAR TIRE TREAD [RX7320(C/C-P)].....4-62  
 FUEL GAUGE .....4-17

**G**

GENERAL PRECAUTIONS .....1-2  
 GENERAL SPECIFICATIONS.....3-2  
 GENERAL SPECIFICATIONS.....3-6  
 GLOW PLUG INDICATOR .....4-20

**h**

HAND THROTTLE LEVER.....	4-37
HANDLING LOADER .....	6-11
HAZARD LAMP SWITCH.....	4-9
HEAD LAMP.....	7-42
HEAD LIGHT HIGH BEAM LAMP .....	4-19
HEAD LIGHT SWITCH.....	4-8
HEATER AND AIR CONDITIONER.....	4-53
HORN SWITCH.....	4-9
HOW TO DRIVE.....	5-11
HOW TO OPEN THE HOOD (A).....	7-8
HOW TO USE QUICK-TURN FUNCTION .....	4-11
HOW TO USE THE SHUTTLE SHIFT LEVER.....	4-31
HOW TO WARM UP ENGINE .....	5-9
HOW TO WARM UP ENGINE (FOR MANUAL TRACTOR).....	5-9

**i**

IMPLEMENT LIMITATIONS.....	3-26
INDEX.....	10-1
INFLATION PRESSURE .....	4-59
INITIAL OPERATION.....	5-2
INSERTING CD/CASSETTE TAPE.....	4-50
INSPECT ALL FOR PROPER OPERATION .....	5-2
INSPECTION.....	7-26
INSPECTION.....	7-36

INSPECTION FRONT AXLE CASE OIL (N1).....	7-17
INSTALLING PTO SHAFT.....	6-9
INSTRUMENT PANEL.....	4-16
INTERIOR DEVICES.....	4-45

**J**

JOYSTICK LEVER .....	4-42
JOYSTICK LEVER .....	6-14
JOYSTICK VALVE PORT .....	6-17
JUMP STARTING .....	5-10

**K**

KEY SWITCH .....	4-7
------------------	-----

**L**

LICENSE PLATE LAMP .....	7-46
LIFTING ARM (LOWER LINK) SPEED CONTROL KNOB.....	4-43
LOADING AND UNLOADING.....	5-18
LONG-TERM STORAGE .....	8-2
LOW FUEL LEVEL WARNING INDICATOR .....	4-24
LUBRICANTS.....	7-7
LUBRICATING GREASE LOCATIONS (P) .....	7-19

**m**

MAIN FUSE (AS).....	7-41
---------------------	------



**m**

MAIN SHIFT LEVER .....4-30  
 MAINTENANCE .....7-1  
 MAINTENANCE CHECK LIST .....7-3  
 MAINTENANCE CODE .....7-8  
 MAINTENANCE SCHEDULE CHART .....7-4  
 MASS(ES) AND TIRE(S).....4-68

**N**

NEUTRAL INDICATOR .....4-22  
 NOISE LEVELS AS PERCEIVED BY THE OPERATOR....3-21

**O**

OILS AND FLUIDS .....2-4  
 OPERATING THE CONTROLS .....4-27  
 OPERATING THE ENGINE .....5-3  
 OPERATING THE TRACTOR .....5-11  
 OPERATION.....5-1  
 OPERATION TIP FOR 3-POINT HITCH ELEMENTS .....6-5  
 OTHER COMPONENTS .....2-5

**P**

PARKING.....5-14  
 PARKING BRAKE LEVER .....4-36

PARKING BRAKE WARNING LAMP .....4-23  
 PARKING WITH LOADER INSTALLED .....6-14  
 POSITION CONTROL.....5-21  
 POSITION CONTROL LEVER .....4-41  
 POWER STEERING LINE (AA) .....7-30  
 PRECAUTION AT OVERHEATING .....7-29  
 PRECAUTION FOR INSTALLING / HOW TO  
 USE TOP LINK HOLES.....6-6  
 PRECAUTIONS BEFORE OPERATION.....1-2  
 PRECAUTIONS BEFORE OPERATION.....2-1  
 PRECAUTIONS DURING OPERATION .....1-5  
 PRECAUTIONS FOR HANDLING .....7-26  
 PRECAUTIONS WHEN COMING IN AND  
 OUT OF WORK FIELD.....5-17  
 PRECAUTIONS WHEN USING POWER STEERING .....5-19  
 PRECAUTIONS WHILE DRIVING ON THE ROAD .....5-17  
 PRE-OPERATION CHECK .....5-2  
 PTO CRUISE.....4-14  
 PTO CRUISE ACTIVATION.....4-14  
 PTO CRUISE DEACTIVATION.....4-15  
 PTO INDICATOR.....4-23  
 PTO SELECTION SWITCH.....4-13  
 PTO SHIFT LEVER .....4-33  
 PTO SWITCH.....4-12

**Q**

QUICK / TURN WARNING LAMP (IF EQUIPPED) .....4-21

**R**

RADIO ANTENNA .....4-50

RADIO CASSETTE/CD PLAYER (IF EQUIPPED) .....4-50

RANGE GEAR SHIFT LEVER .....4-31

READJUSTMENT .....7-29

REAR WINDOW .....4-48

RECIRCULATION/FRESH AIR MODE .....4-53

REGENERATION UNDERWAY BUTTON .....4-13

REGENERATION UNDERWAY LAMP .....4-25

REGENERATION WARNING LAMP .....4-25

REMOTE HYDRAULICS .....5-24

REMOVAL AND INSTALLATION OF 3-POINT  
HITCH IMPLEMENT (WITH PTO SHAFT) .....6-2

REMOVING WATER FROM FUEL FILTER (T1) .....7-22

REPLACEMENT .....7-36

REPLACING AIR FILTER (AI) .....7-33

REPLACING AIR CLEANER FILTER (AF) .....7-32

REPLACING AIR CLEANER PRIMARY ELEMENT (T) .....7-21

REPLACING BULB (AQ) .....7-42

REPLACING CABIN FUSE (AO) .....7-39

REPLACING FUEL FILTER (S) .....7-21

REPLACING FUSE (AN) .....7-38

REPLACING TRANSMISSION FLUID AND FILTER (M) ...7-15

REVERSE INDICATOR .....4-23

RIM BOLT AND NUT TORQUE .....4-63

ROOM MIRROR (IF EQUIPPED) .....4-51

**S**

SAFETY DECAL MAINTENANCE .....1-20

SAFETY PRECAUTIONS .....1-1

SAFETY PRECAUTIONS DURING SERVICING .....1-12

SAFETY PRECAUTIONS WHEN USING THE LOADER ..1-17

SEAT ADJUSTMENT .....4-38

SEAT BACK RECLINING .....4-38

SEAT BELT .....4-39

SEAT HEIGHT ADJUSTMENT .....4-38

SEAT SLIDING .....4-37

SHUTTLE SHIFT LEVER .....4-32

SIDE WINDOW .....4-48

SINGLE ACTING AND DOUBLE ACTING CYLINDER .....5-26

SLOW BLOW FUSE (AP) .....7-41

SPECIFICATIONS .....3-1

SPECIFICATIONS FOR A/C REFRIGERANT  
AND LUBRICANT .....7-48

STANDARD SIZE BY IMPLEMENT .....3-26

STARTING THE ENGINE .....5-3



**S**

STEERING WHEEL ADJUSTMENT.....4-35  
 STOPPING THE ENGINE .....5-7  
 STORAGE AND DISPOSAL.....8-1  
 SUN VISOR (IF EQUIPPED).....4-53  
 SWITCH MOUNTING LOCATION.....4-5

**T**

TACHOMETER/HOURMETER .....4-17  
 TEMPERATURE CONTROL SWITCH .....4-54  
 TIPS FOR BREAKING-IN.....5-2  
 TIRES, WHEELS AND BALLAST.....4-58  
 TRACTOR SERIAL NUMBER.....2-2  
 TRACTOR STORAGE.....8-2  
 TRACTOR TROUBLESHOOTING .....9-4  
 TRANSMISSION SERIAL NUMBER.....2-2  
 TRAVELING SPEED .....3-23  
 TREAD .....4-60  
 TROUBLESHOOTING .....9-1  
 TURBOCHARGER (AU).....7-48  
 TURN SIGNAL LAMP.....4-19  
 TURN SIGNAL LAMP (FRONT) .....7-46  
 TURN SIGNAL LAMP (REAR) .....7-45  
 TURN SIGNAL LIGHT SWITCH.....4-9

TURNING .....5-16

**U**

USAGE AND DISPOSAL.....8-5  
 USING TRACTOR AFTER STORAGE.....8-4

**V**

VEHICLE IDENTIFICATION NUMBER .....2-2  
 VENT MODE CONTROL DIAL.....4-54  
 VIBRATION LEVELS OF THE TRACTOR EXPOSITION TO  
 VIBRATIONS .....3-22  
 VISUAL CHECK ITEMS .....5-2

**W**

WARMING UP .....5-8  
 WATER IN FUEL WARNING LAMP .....4-24  
 WHEEL INSTALLATION DIRECTION .....4-64  
 WHEEL TORQUE AND DIRECTION .....4-64  
 WHEN DRIVING THE TRACTOR .....1-9  
 WHEN LOADED BUCKET AND REAR  
 BALLAST ARE INSTALLED .....6-13  
 WHEN OPERATING THE PTO .....1-11  
 WHEN PARKING THE TRACTOR .....1-11  
 WHEN STARTING THE ENGINE.....1-5





WHEN UNLOADED BUCKET AND REAR  
 BALLAST ARE INSTALLED .....6-13

WHEN USING THE 3-POINT HITCH.....1-12

WIPER .....4-49

WORK LAMP (FRT/RR) .....7-43

WORKING LIGHT .....4-49

