



FOREWORD

Thank you for choosing the **KIOTI ZXS** series brand of stand on mowers. Our products are designed to provide maximum performance and dependability.

The following manual contains important information regarding safety, operation, maintenance and adjustment. Before operating the machine, all users should read and understand the manual in its entirety.

Failure to do so may result in improper use of the machine which could result in personal injury to the operator, bystanders, and/or damage to the machine.

For questions or additional information on these models, or if you should require service for your **KIOTI** product, please contact your authorized selling/servicing **KIOTI** dealer.

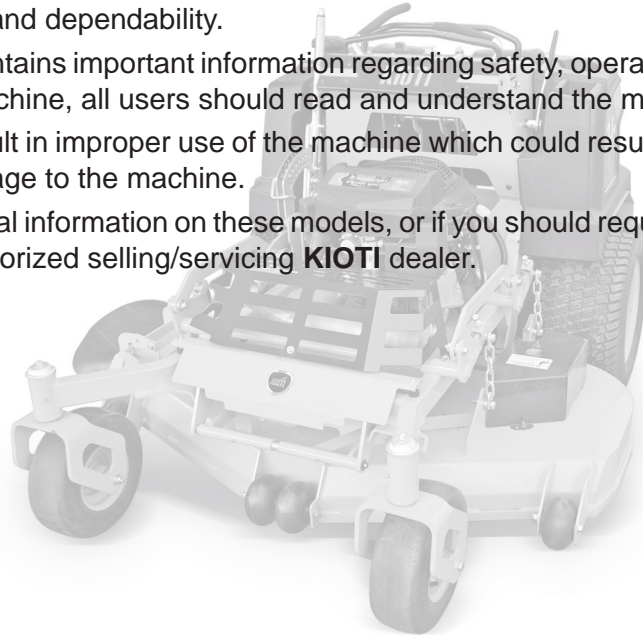

DISCLAIMER

The specifications within this manual are subject to change without notice.



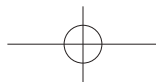
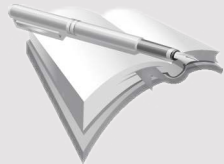



TABLE OF CONTENTS



SECTION

■ <i>SAFETY PRECAUTIONS</i>	1
■ <i>SERVICE</i>	2
■ <i>SPECIFICATIONS</i>	3
■ <i>MOWER CONTROLS LAYOUT</i>	4
■ <i>OPERATION</i>	5
■ <i>MAINTENANCE</i>	6
■ <i>STORAGE AND DISPOSAL</i>	7
■ <i>TROUBLESHOOTING</i>	8
■ <i>INDEX</i>	9



TABLE OF CONTENTS

<p>SAFETY PRECAUTIONS 1-1</p> <p style="padding-left: 20px;">PRECAUTIONS BEFORE OPERATION 1-2</p> <p style="padding-left: 20px;">SAFE OPERATING PRACTICES 1-3</p> <p style="padding-left: 40px;">OWNERS RESPONSIBILITY 1-3</p> <p style="padding-left: 40px;">OPERATING 1-4</p> <p style="padding-left: 40px;">PARKING 1-9</p> <p style="padding-left: 40px;">MAINTENANCE 1-9</p> <p style="padding-left: 40px;">STORING 1-11</p> <p style="padding-left: 40px;">TRANSPORTING 1-12</p> <p style="padding-left: 20px;">SAFETY DECAL MAINTENANCE 1-13</p> <p style="padding-left: 40px;">DECAL MOUNTING LOCATION 1-13</p> <p style="padding-left: 40px;">DECALS 1-14</p> <p style="padding-left: 40px;">DECAL MAINTENANCE 1-15</p> <p>ABOUT SERVICE 2-1</p> <p style="padding-left: 20px;">VEHICLE IDENTIFICATION NUMBER 2-2</p> <p style="padding-left: 40px;">MOWER SERIAL NUMBER 2-2</p> <p style="padding-left: 40px;">ENGINE SERIAL NUMBER 2-2</p> <p style="padding-left: 40px;">TRANSAXLE NUMBER 2-2</p>	<p>SERVICE 2-3</p> <p style="padding-left: 20px;">SUPPLYING SERVICE PARTS 2-3</p> <p style="padding-left: 20px;">SERVICING ENGINE AND DRIVE TRAIN COMPONENTS 2-4</p> <p style="padding-left: 20px;">GENUINE PARTS 2-4</p> <p>SPECIFICATIONS 3-1</p> <p style="padding-left: 20px;">SPECIFICATIONS 3-2</p> <p>TORQUE TIGHTENING CHART 3-4</p> <p style="padding-left: 20px;">SAE FASTENER TORQUE CHART 3-4</p> <p style="padding-left: 20px;">METRIC FASTENER TORQUE CHART 3-5</p> <p>MOWER CONTROLS LAYOUT 4-1</p> <p>EXTERIOR VIEW 4-2</p> <p>DESCRIPTION OF OPERATING SYSTEM 4-3</p> <p style="padding-left: 20px;">KEY SWITCH 4-3</p> <p style="padding-left: 20px;">THROTTLE LEVER 4-3</p> <p style="padding-left: 20px;">FUEL GAUGE 4-3</p> <p style="padding-left: 20px;">HOUR METER 4-4</p> <p style="padding-left: 20px;">STEERING LEVERS 4-4</p>
---	--



TABLE OF CONTENTS

PTO SWITCH	4-5	OPERATION.....	5-9
CHOKE LEVER.....	4-5	STOPPING	5-16
DECK LIFT HANDLE	4-5	MOVING MOWER WHEN THE ENGINE IS STOPPED	5-16
CUTTING HEIGHT PIN	4-6	PARKING	5-17
PARKING BRAKE LEVER.....	4-6	TOWING	5-18
REFERENCE CONTROL FRONT LEVER.....	4-6	TRANSPORTING.....	5-18
CUP HOLDER	4-7	ADJUSTING THE CUTTING HEIGHT.....	5-19
TIRES.....	4-7	OPERATING THE MOWER	5-20
WHEEL	4-8	BATTERY & FUSE LOCATIONS	5-21
OPERATION	5-1	HOW TO LIFT THE MOWER	5-22
DECK.....	5-2	CLEANING THE MOWER DECK	5-23
MOWER DECK INSTALLATION.....	5-2	WASHING MOWER	5-23
MOWER DECK REMOVAL	5-4	MAINTENANCE.....	6-1
OPERATING THE ENGINE	5-5	RECOMMENDED MAINTENANCE SCHEDULES....	6-3
STARTING THE ENGINE	5-5	LUBRICANTS.....	6-5
JUMP STARTING.....	5-7	DAILY CHECKS	6-6
STOPPING THE ENGINE	5-8	GENERAL INFORMATION	6-6
MOWER OPERATION	5-9	CHECKING ENGINE OIL LEVEL	6-6
TIPS FOR BREAKING-IN.....	5-9		



TABLE OF CONTENTS

CHECKING AND ADDING FUEL.....	6-7	EVERY 500 HOURS	6-22
CHECKING AND CLEANING THE AIR INTAKE SCREEN.....	6-9	ADJUSTING THE PTO CLUTCH	6-22
CHECKING THE TRANSAXLE FLUID LEVEL.....	6-9	EVERY 1 YEAR	6-24
LUBRICATION	6-10	REPLACING AIR CLEANER ELEMENT	6-24
EVERY 50 HOURS	6-11	CHECKING THE SPARK PLUGS.....	6-25
AIR FILTER MAINTENANCE	6-11	SERVICE AS REQUIRED.....	6-26
EVERY 100 HOURS	6-12	REPLACING FUSES	6-26
CHANGING THE ENGINE OIL AND FILTER.....	6-12	CHECKING BLADES.....	6-26
CHECKING THE SPARK PLUGS.....	6-13	INSPECTION AND SHARPENING BLADES.....	6-27
CHECKING THE FUEL LINES/FUEL FILTER	6-13	REPLACING BLADES	6-28
ADJUSTING TRANSAXLE DRIVE BELT TENSION....	6-14	REPLACING MOWER BELT.....	6-29
CHECKING THE PARKING BRAKE.....	6-16	ADJUSTING BELT TENSION	6-30
CHECKING AND CHARGING THE BATTERY	6-17	CONTROLS DAMPER ADJUSTMENT	6-30
CLEANING THE ENGINE SHROUD	6-19	ADJUSTING ANTI-SCALP ROLLERS	6-31
EVERY 200 HOURS	6-19	ADJUSTING DECK LEVEL (SIDE TO SIDE).....	6-32
REPLACING ENGINE OIL FILTER	6-19	ADJUSTING DECK RAKE (FRONT TO REAR)	6-33
REPLACING TRANSAXLE OIL AND FILTER.....	6-19	HYDROSTAT TRANSAXLE ADJUSTMENT	6-34
EVERY 400 HOURS	6-21	STORAGE AND DISPOSAL.....	7-1
REPLACING THE FUEL FILTER.....	6-21	MOWER STORAGE	7-2







TABLE OF CONTENTS

DAILY STORAGE..... 7-2
 LONG-TERM STORAGE..... 7-2
 USING MOWER AFTER LONG TERM STORAGE 7-3
USAGE AND DISPOSAL..... 7-4
TROUBLESHOOTING8-1
ENGINE TROUBLESHOOTING 8-2
BATTERY TROUBLESHOOTING.....8-5
MOWER TROUBLESHOOTING 8-6
INDEX.....9-1



SAFETY AND VEHICLE DAMAGE WARNING

This manual includes information titled as **DANGER**, **WARNING**, **CAUTION**, **IMPORTANT** and **NOTE**. These titles indicate the following:

 DANGER	<p>This indicates a hazardous situation which, if not avoided, will result in death or serious injury.</p>
 WARNING	<p>This indicates that a condition may result in harm, serious injury or death to you or other persons if the warning is not heeded. Follow the advice provided with the warning.</p>
 CAUTION	<p>This indicates that a condition may result in damage to your vehicle or its equipment if the caution is not heeded. Follow the advice provided with the caution.</p>
 IMPORTANT	<p>This mark indicates emphasis on notable characteristics of working procedures, and information about technology for easier operation.</p>
 NOTE	<p>This indicates that interesting or helpful information is being provided.</p>



SYMBOLS MARK

Various universal symbols have been used on the instruments and controls of your **KIOTI** mower. Below is a list of the symbols mark and their meanings.



PTO ON



High Speed



PTO OFF



Low Speed

F

Forward



Fuel Level

N

Neutral

R

Reverse

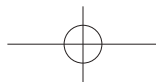



SAFETY PRECAUTIONS

1

1

PRECAUTIONS BEFORE OPERATION 1-2

SAFE OPERATING PRACTICES 1-3

OWNERS RESPONSIBILITY 1-3

OPERATING 1-4

PARKING 1-9

MAINTENANCE 1-9

STORING 1-11

TRANSPORTING 1-12

SAFETY DECAL MAINTENANCE 1-13

DECAL MOUNTING LOCATION 1-13

DECALS 1-14

DECAL MAINTENANCE 1-15



PRECAUTIONS BEFORE OPERATION

To ensure safe mower operation, be sure to read this manual completely and carefully, understanding all aspects of operation and safety precautions. Only use the machine in accordance with the safety guidelines within this manual.

The safety symbols such as danger, warning, and caution are displayed throughout the mower. Please follow the decal advisement when operating the mower.

NOTE

- Please read this manual carefully.

For best cutting performance, always mow with the throttle lever in the wide open position.



1. Please wear the appropriate work clothes. Avoid loose clothing and jewelry. Tie back long hair. Failure to adhere can cause safety issues during operation or maintenance of this machine.
2. Survey the area you plan to cut before operating the mower. Identify any safety hazards as well as areas unsuitable for safe mower operation.
3. Remove all hazards such as stones, wires, wood, large sticks and other

foreign objects from the mowing area before cutting. Make sure there are no people or pets in the mowing area that could be injured from debris ejected from the mower deck.

4. Gasoline is highly flammable and has the danger of fire and/or explosion. To prevent injury and property damage, adhere to all flammable warnings on the machine, the gas dispenser, and follow safe practices during fueling. Do not fuel a machine when hot.

Always fill the fuel tank outdoors, never in-doors or inside enclosed trailers. Use a funnel or spout to prevent fuel spillage. Clean up any spillage before starting the machine.

When refueling make sure you are in an open and well ventilated space as sparks may occur while refueling due to static electricity. Avoid refueling in enclosed areas or poorly ventilated areas as that



SAFE OPERATING PRACTICES OWNERS RESPONSIBILITY

can lead to personal and property damage from fire or explosion caused by fuel.

5. Use only approved fuel containers when storing fuel.
6. Equipment used for fueling must comply with the SAE J137 and/or ANSI/ASAE S279 when driven on public roadways.
7. Gasoline is harmful or fatal to the human body. Long term exposure to vapor may cause cancer or other diseases, so please wear protective equipment or avoid inhaling vapor.
8. Inspect the machine and attachments before each use to ensure they are in good working condition. If issues are found, do not operate until they are fixed or resolved.
9. Always keep the machine clean. Built up dust, oil and debris can cause a fire, leading to injury.

10. Always check tire pressure, engine oil level, and fuel level before operating.
11. Before refueling: Make sure the engine is off and has cooled off. Hot engine parts can potentially ignite spilled fuel.
12. Do not operate without the side discharge chute installed and in the down position, unless a grass catcher or mulch plate is installed.
13. Check the blade mounting bolts before each use to ensure proper tightness.

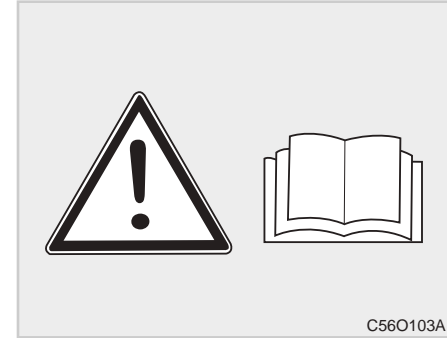

1

If owner intends to loan or rent the machine to another party, it is the owner's responsibility to provide a copy of the manual and explain the safe operation guidelines as outlined in this manual. The following points should be covered:

1. The Operators should be familiar with the safe operation of the machine, driver controls, and safety symbols.
2. All operators and mechanics need



OPERATING

to be trained, before operating the mower.

3. Do not allow unqualified or untrained people to operate or repair the equipment.
4. The following should never be allowed to operate this machine:
 - Those under the influence of alcohol or drugs.
 - Women that are pregnant.
 - Those under 18.
 - Those without driver's license.
 - Those who are fatigued, sick, or have a medical condition that may prevent normal operation.
5. Do not wear headphones to listen to music or audio while operating this machine.
6. Disclaimer: If damage or injury occurs to persons or property as a direct result of operator error, the operator and/or the owner is liable.

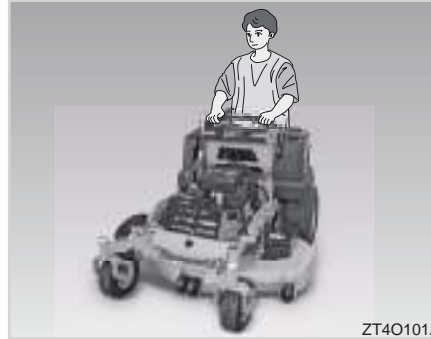

The safety of this machine depends on the Operator! Failure to adhere to the safety information contained within this manual may result in bodily injury or death. The ability to assess potential hazards and accident prevention are dependent on the training and awareness of the persons involved in the transport, operation and storage of this equipment. It is the owner's responsibility to make sure every operator is properly trained on the

safety information and the operation of this machine. The owner is liable for any damage to property, or injuries occurring to themselves or other people.

WARNING

- ***DO NOT operate this mower on steep slopes. To check if the slope is too steep, attempt to back the mower up the edge of the slope with the mower deck in the down position. If the wheels do not slip or loose traction, proceed as slow as possible with extreme caution.***

1. Only allow people that are proficient in operating and are familiar with safe driving to operate this mower.
2. Before starting the engine, make sure the PTO switch is in the OFF position, and that the parking brake is ON.



3. If starting engine indoors, make sure the area is well ventilated so exhaust fumes can escape.
4. Only operate the mower in clear weather during the daytime or early evening with proper artificial lighting. Do not operate during rainy weather or during thunderstorms. Mowing in wet conditions will reduce the quality of the grass cut and can cause loss of traction.

 **NOTE**

- If caught in a storm, stop the machine immediately and seek shelter.

5. Be careful not to touch hot parts with your body or foreign objects.

 **CAUTION**

- **Engine parts during operation become very hot. Do not touch engine, muffler or moving parts. Make sure that these areas are kept free from foreign matter such as leaves or grass.**

6. Never carry passengers. Do not operate the mower, especially when children or pets are in the work area.
7. Be careful when approaching corners, shrubs, trees, or other objects that may obscure your vision.
8. Avoid excessive, sudden stops, as well as rapid accelerations, especially at high speeds. Failure to do so may cause loss of control, leading to damage or injury.
9. Avoid driving on steep banks with loose, eroded soil conditions or wet grass.

10. When working in groups, always communicate the work plan with the group to avoid safety issues.
11. When backing up, always turn your head and look backwards.
12. During operation: scan the ground ahead of you for obstructions, especially at row ends, near trees and other obstructions.
13. Never attempt to exit a mower in motion, unless your life is in danger and it is the only option. Always stop the mower, turn the PTO off, engage the park brake and turn the engine off before exiting the machine.
14. To minimize risk of overturning, be sure to slow down when turning or operating on slopes or rough terrain.

15. Always hold the steering levers with both hands and place both feet on the machine's floor when driving.
16. Do not operate the machine without the mower deck installed.
17. Do not mow grass in reverse.
18. If the mower chute becomes clogged, ensure the engine is off, the PTO is off, the steering levers are in neutral, the parking brake is set and the blades have come to a complete stop, before attempting to clear the discharge.
19. When using attachments, ensure the discharge of material does not affect bystanders while in operation.
20. In the event steering control is lost due to terrain or a mechanical issue, immediately bring the unit to a stop by returning the steering levers to neutral. Apply the parking brake, turn the PTO off and turn the engine off. Be sure the machine is not moving and the blades have completely

stopped rotating before dismounting and inspecting the machine or field conditions.

WARNING

- **DO NOT use hands to dislodge a clogged discharge chute. Use a stick or similar item to remove clogged material only after the engine is turned off, PTO off, the steering levers are in neutral, the parking brake is set and the blades have stopped completely.**

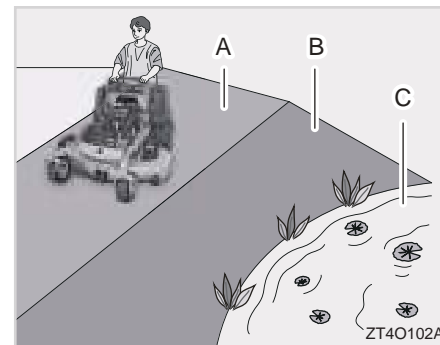

- (A) Safe Range (Slope less than 15 degrees)
 (B) Dangerous Range (Slope more than 15 degrees)
 (C) Water

WARNING

- **DO NOT operate this mower on steep slopes. To check if the slope is too steep, attempt to back the mower up the edge of the slope with the mower deck in the down position. If the wheels do not slip or lose traction, proceed as slow as possible with extreme caution.**



1. Be careful when stopping or turning mowers on a slope, as it may cause loss of traction or overturning. It is the responsibility of the operator to use caution. Drive safely on a slope.
2. When working on a slope, pay additional attention to traction. Should the machine begin to lose traction, slide or show any signs of erratic control, carefully maneuver the mower off the slope. Should the machine lose traction and stop on a slope, return the steering levers to neutral, apply the park brake, turn the PTO off and turn the engine off. Carefully dismount the mower after the blades have stopped rotating and inspect the conditions before determining if the mower can be operated further. In extreme instances, assistance may be required to safely maneuver the mower off the slope.
3. Driving on wet grass over steep slopes may cause loss of traction and control. Slipping on or around

ridges, ditches, steep banks, and wheels falling into water can cause loss of control or overturning, which can result in severe injury or death. Determine if the area can be safely navigated with the mower before attempting to cut.

4. Do not operate mower on a slope when wet, especially slopes greater than 15 degrees. Failure to adhere may cause loss of control.
5. Remove obstacles such as stones and trees in the work area or mark them. Always be on the look out for obstacles, tall grass and/or weeds can hide obstacles.
6. Use extra caution when operating the mower around drop offs, ditches, steep banks or water. Do not try to work too closely to edges as this could lead to a loss of control or rollover.

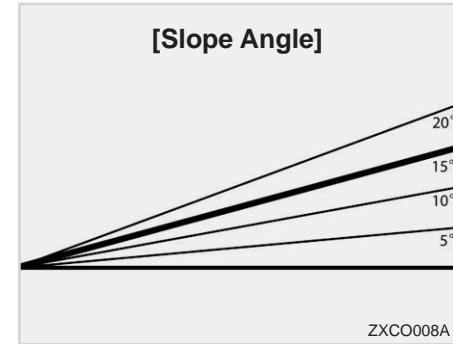

1

7. Always slow down when changing directions, especially on slopes, rough, tough, or uneven terrain.
8. Avoid sudden accelerations when traveling uphill as this may cause the mower to tilt backwards and loose control.
9. Keep in mind that wet grass, steep slopes or downhill roads can cause the mower to lose traction.



10. Operating on sloped, rough terrain at high speeds can cause the mower to overturn. Be familiar with the area and its characteristics before operating the mower.
11. Always avoid suddenly starting or stopping on slopes. If the tire loses its grip, disengage the PTO and slowly pull out of the slope.
12. Use caution when operating machine on inclines when a grass catcher is installed.
13. Survey the cutting area to identify holes, rocks, roots and other hidden hazards on the terrain. Keep away from any steep slopes or drop-offs. Be aware of any overhead obstructions, such as low hanging tree limbs or building overhangs.
14. Disengage the PTO switch to stop the blades from spinning before backing the mower up in reverse. Do not mow in reverse unless it is absolutely necessary, move slowly and maintain a constant lookout for hazards. Be sure to survey the area before operating in reverse.
15. Disengage the PTO switch to stop the blades from spinning before crossing side walks, roadways or gravel drives.
16. In the event of hitting an obstacle during cutting, stop the machine immediately disengage the PTO, apply the parking brake and turn the engine OFF. After the blades have stopped rotating, inspect for damage to the cutting blades and mower. If damage has occurred, repair the damage before restarting and operating the machine.



WARNING

- ***Stay off slopes too steep for safe operation. To check if the slope is too steep, attempt to back the mower up the edge of the slope with the mower deck in the down position. If the wheels do not slip or lose traction, proceed as slow as possible with extreme caution. Operate the machine smoothly with no sudden starts or turns.***
- ***Under no circumstances should this machine be driven on slopes greater than 15 degrees.***

**⚠ WARNING**

- **Always reduce speed when operating on slopes, turning and when traveling over wet or slick surfaces.**
- **Do not operate near embankments, ditches or drop-offs. Failure to adhere may cause a roll over.**
- **Use caution when loading and unloading the machine onto trucks or trailers. Back up the ramp to load and drive down the ramp forward to unload.**
- **Use only an approved full width loading ramp with an angle no greater than 15 degrees.**
- **No untrained personnel should be permitted to operate, load or unload the machine.**
- **Do not tow or haul anything with this mower.**

PARKING

1. Before dismounting: Disengage the PTO, place all control levers in the neutral lock position, set the parking brake, stop the engine.
2. Never leave the vehicle without setting the parking brake, disengage the PTO and shutting off the mower.
3. The mower should be parked on a flat level surface, however, if parking on a slope is unavoidable, chock the wheels appropriately after setting the parking brake.
4. If a malfunction occurs while on a public roadway, pull off the roadway to a safe area away from traffic to make repairs.

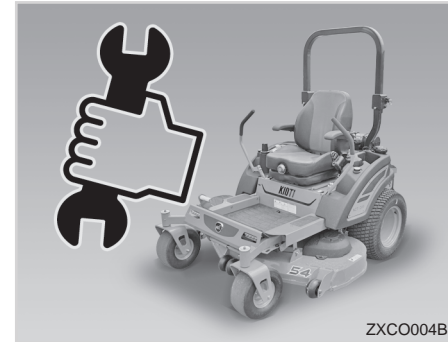
MAINTENANCE

1. Before servicing, make sure the PTO is in the off position, the control lever levers are in "N", the parking brake is set, and the engine is turned off.
2. Do not smoke while working around the battery or when refueling your machine. Keep all sparks and flames away from the battery and fuel tank. The battery presents an explosive hazard because it gives off hydrogen and oxygen especially when recharging.



3. Before servicing any engine or mechanical mower parts, allow the mower to adequately cool down after operation.
4. Before working on the mower electrical system, first disconnect the negative (-) battery cable from the battery terminal post.
5. For jump starting a dead battery, read and follow all of the instructions in chapter 5. (Ref to page 5-6)
6. Tire mounting should only be done by qualified professionals, with the proper equipment.
7. Maintaining correct tire pressure is important for the life of your tires. Do not inflate the tires above the recommended pressure specified in the owner 's manual. (Ref to page 4-16)
8. Securely support the vehicle when changing wheels.

9. No alterations or modifications should be made to the machine. Alterations or modifications may adversely affect function and/or performance of the unit, cause safety issues, and void the manufacturer warranty.
10. Help **KIOTI** protect the environment. When changing fluids, make sure that they are contained and disposed of properly. Be sure to observe all relevant regulations for the handling and disposal of engine oil, trans-axle fluid, fuel, filters, and batteries.
11. Do not dispose of waste fluids on the ground, into storm drains or natural bodies of water. Find an appropriate way to dispose of fluids in an environmentally friendly manner or recycle it through the recycling center.
12. When disposing of engine oil, transmission oil dispose of it in a place equipped with disposal facilities. Failure to observe this

may cause environmental pollution.

13. Reinstall the covers that have been removed by inspection, maintenance, etc., after the maintenance check.
14. To avoid injuries when inspecting the condition of the mower blades, wear gloves or cover the blade before touching. If damage is found, replace the blade. Do not attempt to straighten bent blades, this will affect the performance and strength of the blade.
15. Please keep first aid kits and fire extinguishers nearby to in case of emergency.
16. Do not attempt to adjust or repair the engine during operation.
17. Never perform maintenance to this machine while the engine is running unless specifically specified to do so by the engine manufacturer. Keep hands, feet, and loose clothing away from all moving parts.



18. Before performing maintenance or cleaning, make sure the machine is on a level, safe surface, the PTO switch is in the off position, the steering levers are in the neutral position, the parking brake is set and the engine is turned off.
19. Disconnect the negative (-) battery terminal before proceeding with any repairs.
20. Do not change any engine settings, especially the governor settings. See the manufacturer's engine manual for information on engine settings.
21. Keep the mower deck, spindles, engine and muffler free of lawn debris, excessive oil and dirt to reduce the chance of a fire hazard.
22. Use care when checking the cutting blades. Do not touch the blades directly, wear safety gloves or use a blade buddy to hold the blades during removal.
23. Only Replace a worn or bent blade. NEVER straighten or weld a worn blade.
24. Use jack stands to support the machine or components when required. NEVER use a jack alone to support the machine while performing work.
25. NEVER use your hands to inspect fluid lines (gas lines, hydraulic lines, oil lines) for leaks. Fluid under pressure can puncture the skin and lead to serious health issues.
26. Always wear eye and hand protection when servicing or making repairs to the mower.

STORING

1. After daily operation, clean unit and store indoors as much as possible.
2. For other detailed storing methods and precautions, see Storage and Disposal in chapter 8.
3. Let the engine cool completely before storing.
4. DO NOT store machine near open flames.
5. DO NOT store fuel near flames or drain the fuel indoors.
6. Charge batteries in open, well ventilated area, away from spark and flames. Unplug charger before connecting or disconnecting battery. Wear protective clothing and eye protection when handling a battery.



TRANSPORTING

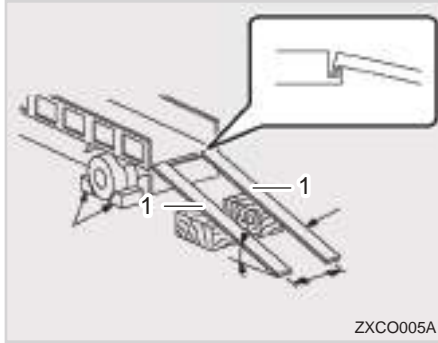

(1) Loading Ramps

1. Check the width of the cargo bed of a transporting vehicle or trailer.
2. Set ramps to the transporting vehicle firmly.
3. The length of the loading ramps should be at least four times the height of the loading bed.
4. It is recommended to back the mower onto the transporting vehicle and drive the mower OFF in the forward direction.
5. Be sure to keep the speed down when loading/unloading.
6. After loading the mower onto the transport vehicle, secure the mower first by setting the parking brake, then tying down to the transport with chains or straps. Utilize the tie down points built into the mower to not damage the mower during transit.
7. During vehicle transporting, pay attention to motor vehicle laws, mark the transport with the applicable decals or markings.
8. Be sure to Confirm the overall height of the vehicle with the mower loaded, make sure that does not exceed the maximum height for travel under bridges or through tunnels.





SAFETY DECAL MAINTENANCE DECAL MOUNTING LOCATION

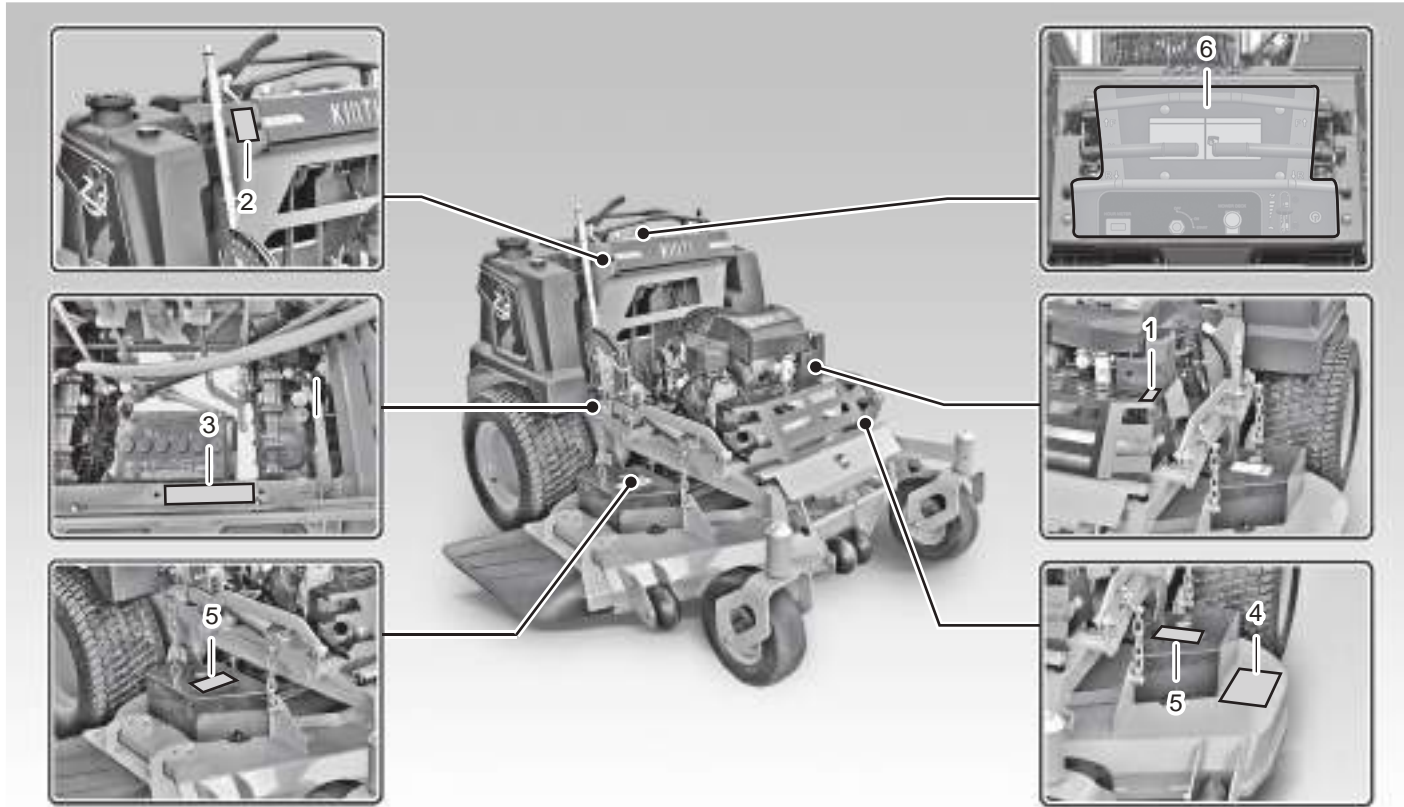

1

ZT40104A

DECALS

1. Part No.: Z2131-95241



3. Part No.: Z2131-95231

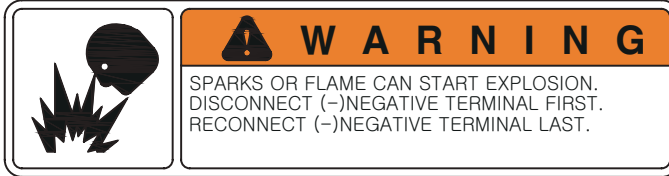

2. Part No.: Z2131-95211

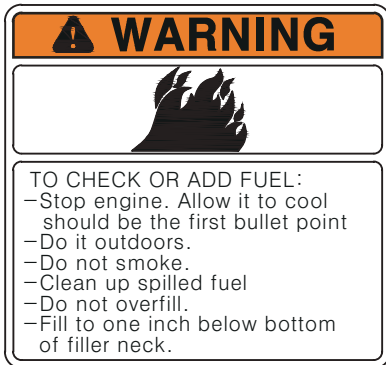

4. Part No.: MM605-12434

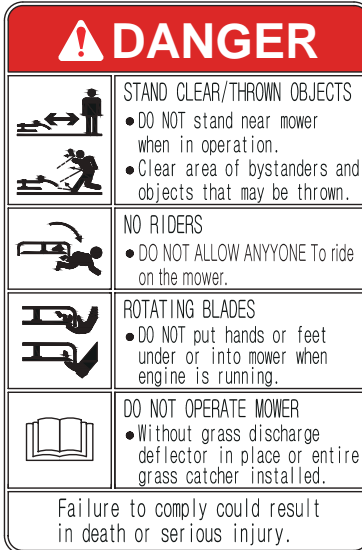

5. Part No.: MM605-12422

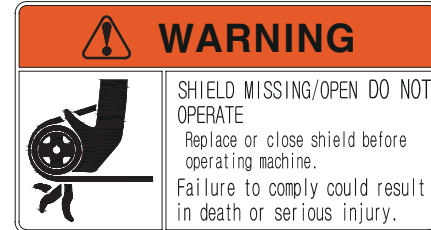



6. Part No.: Z2191-97204

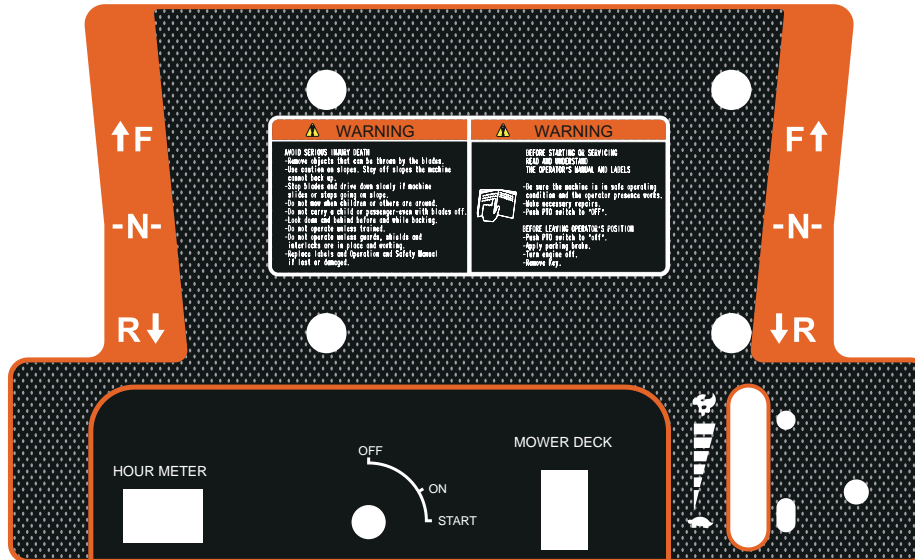

DECAL MAINTENANCE

Safety decals are attached to the mower for safe operation. Make sure to follow the instruction on the decals as well as the following instructions:

1

CAUTION

- Keep the decals clean and intact. If any decal is dirty, wash it with soap and dry with a soft cloth.
- Never use a solvent, such as a thinner or acetone, since it can ruin the decals.
- Do not spray high-pressure water directly onto the decal. The decal may be damaged.
- If a decal is damaged or lost, contact your local KIOTI dealer immediately to install a new decal.
- When applying a decal, clean the mounting surface first and attach a new decal in the correct position, press gently to remove air bubbles.
- If a decal is attached to a component to be replaced, replace the decal as well.



MEMO





ABOUT SERVICE

VEHICLE IDENTIFICATION NUMBER	2-2
MOWER SERIAL NUMBER.....	2-2
ENGINE SERIAL NUMBER.....	2-2
TRANSAXLE NUMBER	2-2
SERVICE	2-3
SUPPLYING SERVICE PARTS.....	2-3
SERVICING ENGINE AND DRIVE TRAIN COMPONENTS.....	2-4
GENUINE PARTS.....	2-4

2

2



**VEHICLE IDENTIFICATION NUMBER
MOWER SERIAL NUMBER**



ZT4O202A

(1) Model and Serial Number Plate

The serial number is located at the upper left part of the main frame on the front wheel bracket.

ENGINE SERIAL NUMBER



ZT4O201A

(1) Engine Serial Number

The engine model and serial number can be found on the label attached to the left covers of the engine.

TRANSAXLE NUMBER

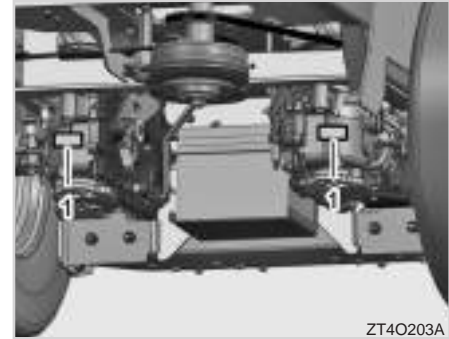

ZT4O203A

(1) Transaxle Serial Number

The transaxle serial numbers are attached to the left and right transaxle cases.





SERVICE

Your local **KIOTI** dealer has the right service solutions for all of your **KIOTI** products and can provide the correct methods for service and maintenance. We recommend you contact your authorized **KIOTI** dealer for all repairs. Use only approved **KIOTI** service parts from an authorized dealer.

NOTE

- The replacement of any parts on this machine by any other manufacturer other than original **KIOTI** brand parts(Kawasaki for engine parts) may adversely affect the performance, safety or longevity of this machine.
- Use of anything other than original **KIOTI** brand parts will void the manufacturers warranty.

In case of mechanical trouble, refer to “Troubleshooting” in chapter 8 of this manual. If the problem cannot be corrected, please contact your nearest authorized **KIOTI** dealer.

► INFORMATION REQUIRED BEFORE CONTACTING A DEALER

- Model and product serial number.
- In case of engine, the engine serial number.
- Circumstances of breakdown. (Work performed at time of failure)
- Other information in as much detail as possible surrounding the circumstances of the breakdown.

SUPPLYING SERVICE PARTS

Service parts for this machine are available through your local authorized **KIOTI** dealer. When it comes to special parts during the service term, please contact your dealer ahead of time to confirm parts availability, to avoid downtime of the machine.



2-4 ZXS SERIES MOWER

SERVICING ENGINE AND DRIVE TRAIN COMPONENTS

The detail service and repair of the engine, hydraulic pumps and gearboxes are not covered in this manual. Any of these components needing service, especially during the limited warranty period, should only be performed by your authorized **KIOTI** dealer. Any unauthorized work performed during the limited warranty period may void the warranty.

GENUINE PARTS

KIOTI genuine (OEM) parts and fluids pass the strictest standards for quality and performance. Please use only genuine **KIOTI** parts for safety and longevity.



SPECIFICATIONS

SPECIFICATIONS..... 3-2

TORQUE TIGHTENING CHART..... 3-4

SAE FASTENER TORQUE CHART.....3-4

METRIC FASTENER TORQUE CHART.....3-5

3

3

SPECIFICATIONS

ITEM		ZXS48	ZXS54	REMARKS
ENGINE	Model	Kawasaki FX730V	Kawasaki FX730V	
	Engine Gross	HP (kW)	24 (17.9)	24 (17.9)
	Displacement	cu.in. (cc)	44.3 (726)	44.3 (726)
	Choke		Manual Lever	Manual Lever
	Fuel Tank Capacity	gal. (L)	7 (27)	7 (27)
	Fuel Requirement		87 Octane of higher	87 Octane of higher
DRIVE TRAIN	Model	Hydro-Gear ZT-3400	Hydro-Gear ZT-3400	
	Displacement Pump/Motor	cc	12 / 16	12 / 16
PTO	Clutch	lb./ft. (kgf./m)	200 (27.6)	200 (27.6)
TIRE SIZE	Front		13x5-6	13x5-6
	Rear		23x10.5-12	23x10.5-12
TRAVELING SPEED	Forward	m/p (km/h)	10.5 (16.9)	10.5 (16.9)
	Reverse	m/p (km/h)	3.5 (5.6)	3.5 (5.6)





ITEM		ZXS48	ZXS54	REMARKS
DIMENSIONS	Overall Length	in. (mm)	65.0 (1,650)	65.0 (1,650)
	Overall Width	in. (mm)	60.6 (1,540)	68.5 (1,740)
	Overall Height	in. (mm)	47.2 (1,200)	47.2 (1,200)
	Approx. Curb Weight	lb. (kg)	992 (450)	1,014 (460)
MOWER DECK	Mower Deck Type		Fabricated	Fabricated
	Lift Mechanism		Hand Lever	Hand Lever
	Deck Steel Thickness		10-gauge with 7-gauge at edge area	10-gauge with 7-gauge at edge area
	Anti-Scalp Ball Rollers		5 (4 front, 1 rear)	6 (4 front, 2 rear)
	Cutting Width of Mower	in. (mm)	48 (1,219)	54 (1,372)
	Blades		Notched	Notched
	Cutting Height	in. (mm)	1.5 - 4.5 (38.1 - 114.3)	1.5 - 4.5 (38.1 - 114.3)
	Discharge Chute		Molded Rubber	Molded Rubber
Deck Height Adjustment		Pin	Pin	

※ The specifications are subject to change without notice.

TORQUE TIGHTENING CHART SAE FASTENER TORQUE CHART

SAE FASTENER TORQUE CHART

Note : Use these torques, unless special torques are specified. Values are for UNC and UNF thread fasteners, plated or unplated as received from supplier. Fasteners can be dry or lubricated with normal engine oil.
Values do not apply if graphite, moly-disulphide or other extreme pressure lubricant is used.

SAE Grade	2				5				8*			
Bolt head identification (see note 1)												
Bolt Size	lb-ft				lb-ft				lb-ft			
	Min.	Max.	Min.	Max.	Min.	Max.	Min.	Max.	Min.	Max.	Min.	Max.
1/4	5	6	7	8	9	11	12	15	12	15	16	20
5/16	10	12	14	16	17	20.5	23	28	24	29	33	39
3/8	20	23	27	31	35	42	48	57	45	54	61	73
7/16	30	35	41	47	54	64	73	87	70	84	95	114
1/2	45	52	61	70	80	96	109	130	110	132	149	179
9/16	65	75	88	102	110	132	149	179	160	192	217	260
5/8	95	105	129	142	150	180	203	244	220	264	298	358
3/4	150	185	203	251	270	324	366	439	380	456	515	618
7/8	160	200	217	271	400	480	542	651	600	720	814	976
1	250	300	339	406	580	696	787	944	900	1080	1220	1464
1 1/8					800	880	1085	1193	1280	1440	1736	1953
1 1/4					1120	1240	1519	1681	1820	2000	2468	2712
1 3/8					1460	1680	1980	2278	2380	2720	3227	3688
1 1/2					1940	2200	2631	2983	3160	3560	4285	4827

Note : Bolt head identification marks as per grade. Manufacturing marks will vary. * Thick nuts must be used with Grade 8 bolts.



METRIC FASTENER TORQUE CHART

METRIC FASTENER (ISO) TORQUE CHART						
Note : Use these torques, unless special torques are specified. Values are for UNC and UNF thread fasteners, plated or unplated as received from supplier. Fasteners can be dry or lubricated with normal engine oil. Values do not apply if graphite, moly-disulphide or other extreme pressure lubricant is used.						
ISO Class No.	8.8		10.9		12.9	
Bolt head identification (see note 1)	8.8		10.9		12.9	
Bolt Size	Nm		Nm		Nm	
	Min.	Max.	Min.	Max.	Min.	Max.
M4	3	4	4	5	Because of the low ductility of these fasteners, the torque range is to be determined individually for each application. As a general rule, the torque ranges specified for grade 10.9 fasteners can be used satisfactorily on 12.9 fasteners. * M14 is not a preferred size.	
M5	6.5	8	9.5	11		
M6	10.5	12	15	17.5		
M8	26	31	37	43		
M10	52	61	73	87		
M12	90	107	125	150		
*M14	144	172	200	245		
M16	217	271	310	380		
M20	434	515	610	730		
M24	675	815	1050	1275		
M30	1250	1500	2000	2400		
M36	2175	2600	1120	1240		

Note : Bolt head identification marks as per grade. Manufacturing marks will vary.



MEMO





MOWER CONTROLS LAYOUT

4

4

EXTERIOR VIEW	4-2
DESCRIPTION OF OPERATING SYSTEM	4-3
KEY SWITCH.....	4-3
THROTTLE LEVER.....	4-3
FUEL GAUGE	4-3
HOUR METER.....	4-4
STEERING LEVERS.....	4-4
PTO SWITCH	4-5
CHOKE LEVER	4-5
DECK LIFT HANDLE	4-5
CUTTING HEIGHT PIN.....	4-6
PARKING BRAKE LEVER	4-6
REFERENCE CONTROL FRONT LEVER	4-6
CUP HOLDER	4-7
TIRES.....	4-7
WHEEL.....	4-8



EXTERIOR VIEW

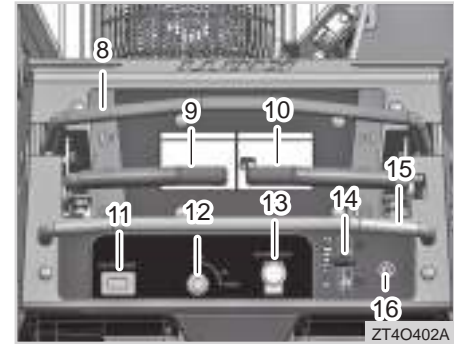
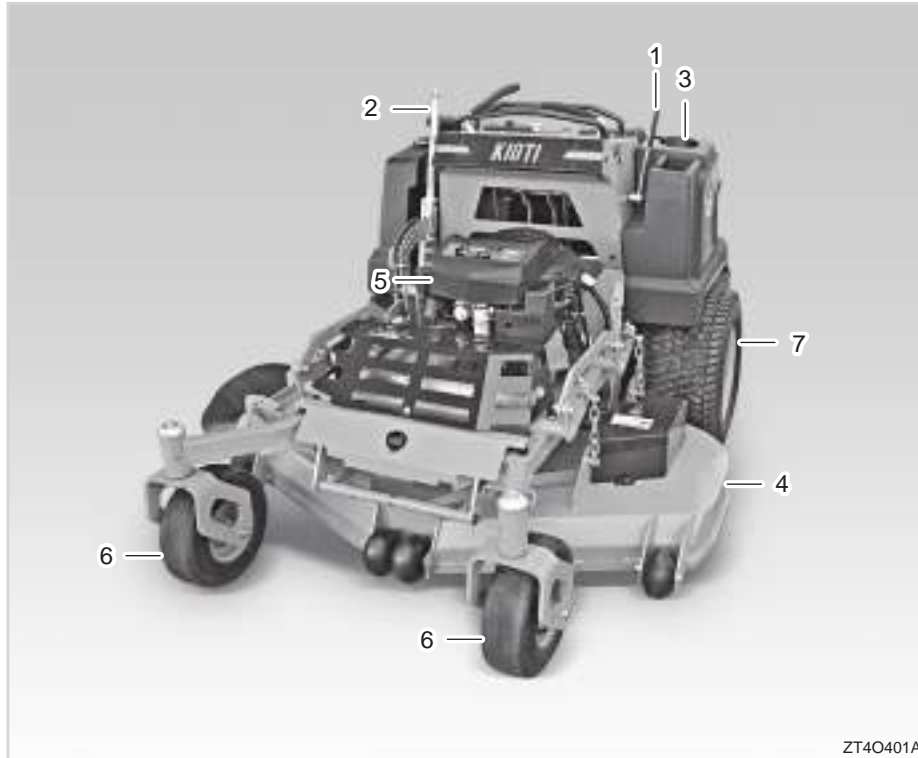

- (1) Parking Brake Lever
- (2) Deck Lift Control Lever
- (3) Cup Holder
- (4) Deck
- (5) Engine
- (6) Front Wheel
- (7) Rear Wheel
- (8) Front Reference Bar
- (9) LH Steering Lever
- (10) RH Steering Lever
- (11) Hour Meter
- (12) Key Switch
- (13) PTO ON/OFF Switch
- (14) Throttle Lever
- (15) Rear Reference Bar
- (16) Choke Lever

DESCRIPTION OF OPERATING SYSTEM KEY SWITCH





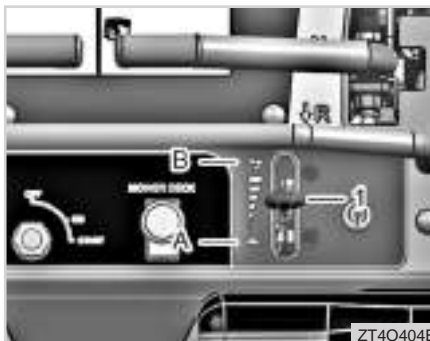

(1) Key Switch
(A) OFF (B) ON (C) START

To start the engine, insert the ignition key into the switch and turn it clockwise to the START position. There are three positions on the key switch: OFF, ON and START

THROTTLE LEVER



(1) Throttle Lever
(A)  : Low Speed (B)  : High Speed

Move the engine speed lever to LOW SPEED() or HIGH SPEED() to adjust the engine RPM's.

FUEL GAUGE



(1) Fuel Gauge
(A) Empty (B) Full

You can visually check the amount of fuel without removing the fuel cap. If you continue to operate while you are running low on fuel, air may enter the fuel supply, so be sure to refill before the gauge reaches the empty position.



⊕ IMPORTANT

- Make sure to use only automotive unleaded 87 octane or higher fuel that does not to exceed 10% ethanol. Any other type/rated fuel may cause damage to the engine or mower components.
- It is recommended to treat fuel to prevent deterioration for long-term or winter storage. In cold climates, use winter blended fuel to prevent moisture intrusion and starting issues.

HOUR METER



(1) Hour Meter

The hour meter indicates the total run time of the machine.

STEERING LEVERS



(1) LH Steering Lever (2) RH Steering Lever

⚠ CAUTION

- Do not move steering levers from forward to reverse or reverse to forward position rapidly. Sudden direction changes could cause loss of control or damage to the machine or property.
- Operate at low travel speeds until you are used to operating the machine or become familiar with its operating characteristics.

PTO SWITCH



(1) PTO Switch
(A) Disengage (B) Engage

Pull the switch upward to engage the blades. Push the switch down to disengage the blades.

NOTE

- When leaving the operator stand or to stop mowing, be sure to disengage the PTO by pushing the switch downward.
- Do not engage the blades until you are ready to start mowing.

CHOKE LEVER

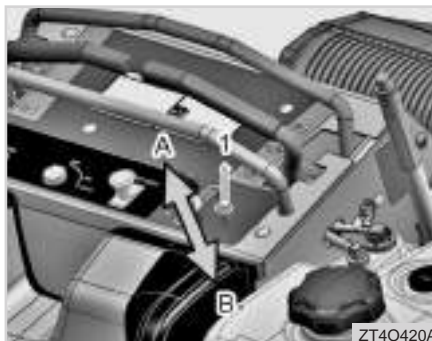

(1) Choke Lever
(A) ON (B) OFF

The Choke lever is used when starting the engine from a cold start. Before starting the engine, pull the choke lever to the fully open position and then start the engine. Once the engine is running, push the choke lever back to its resting position. When the lever is pulled, it turns ON, and when pressed, it turns OFF.

DECK LIFT HANDLE



(1) Deck Lift Handle

To lower the mower deck, pull back slightly on the handle or depress the button to release the lock. Then lower the handle (Move forward) until the lever touches the cutting height pin.

To raise the deck, pull the handle (Move rear ward) until the handle locks into the travel position.



CUTTING HEIGHT PIN



ZT4O413A

(1) Cutting Height Pin

Adjust the cutting height by placing the cutting height pin in the position corresponding to the desired cut height.

PARKING BRAKE LEVER



ZT4O412A

(1) Parking Brake Lever
(A) Engaged (B) Disengaged

Pull this lever rearward to the park position to engage the brakes before dismounting the mower. This also locks the control handles. The parking lever must be in the parked position to start engine.

CAUTION

- To Prevent unwanted mower movement, when exiting the machine, always apply the parking brake and stop the engine by turning the key to the OFF position

REFERENCE CONTROL FRONT LEVER

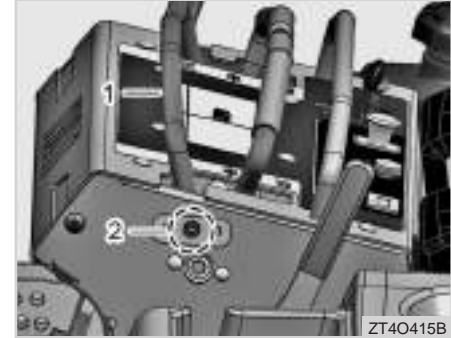

ZT4O415B

(1) Reference Control Front Lever
(2) Adjust Bolt

Loosen the adjusting bolt to move the reference bar back and forth. Now select the bolt hole which is comfortable for your hands then tighten the bolt. The position of the lever will also set the maximum forward position of the steering levers.



CUP HOLDER



(1) Cup Holder

The cup holder is conveniently positioned at the top of the left fuel tank to allow cans or cups to be stowed. Be careful when traveling over bumps or on slopes as drink may be ejected.

TIRES

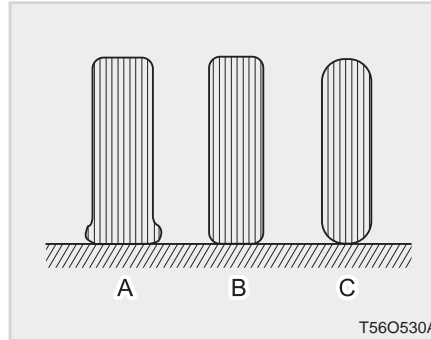

(A) Under Inflated (B) Properly Inflated
(C) Over Inflated

Tire pressure is filled to the required psi at the factory. The pressure will fluctuate with ambient air temperature. Check and adjust the tire pressure before each use.

ITEM	MAXIMUM TIRE INFLATION PRESSURE
Front	280 kPa (2.8 kgf/cm ² , 40 psi)
Rear	152 kPa (1.5 kgf/cm ² , 22 psi)

 **WARNING**

- *Inflating air above the specified pressure may cause the tire to rupture and result in an accident.*
- *Do not attempt to remove the tire from the wheel. If service is necessary, take wheel/tire assembly to a qualified tire service center or your local KIOTI authorized dealer.*

 **CAUTION**

- **Do not operate with loose rim, wheels, or axle bolts.**
- **If bolts are loose, tighten them to the specified torque and check them frequently.**

 **IMPORTANT**

- **Do not use tires other than the size or type specified for your mower.**

WHEEL

FRONT WHEEL

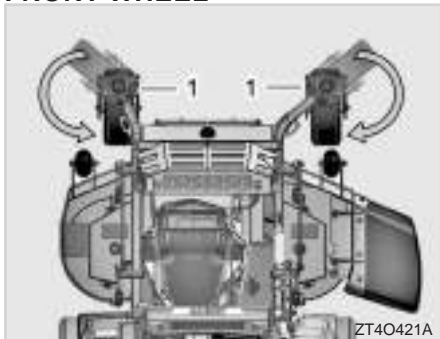

(1) Wheel & Wheel Support Fork Bracket

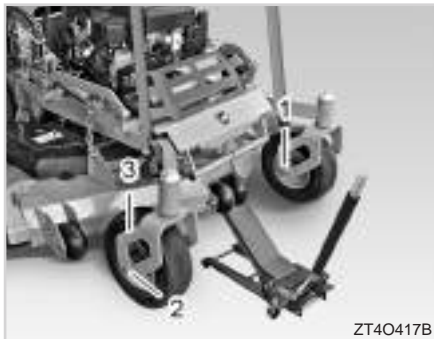
(1) Nut (2) Wheel Bolt
(3) Wheel Support Fork Bracket

To install or remove the front wheel, follow the steps below:

1. Park the machine on a flat surface, stop the engine, and engage the parking brake.
2. Rotate both the left and right wheel forks so the wheel/fork combination is pointed towards the mower (same position as when the mower is traveling forwards)
3. Position a jack underneath the

crossbar that supports the front deck trail arms. Reference P. 5-20 for additional information if needed.

Once raised, support the unit by placing jack stands underneath the frame directly behind the front wheel forks

4. Remove the nuts and wheel bolts, then remove the wheel from the support fork.

5. Remount the wheels into the support fork bracket, oriented towards the mower for forward movement, then insert the wheel bolt from the outside. Tighten to the torque specs listed below.

⊕ IMPORTANT

- Insert the front wheel bolt from the outside of the bracket.
- Be sure to tighten the nut slowly while rolling the wheel by hand so that it rotates smoothly during operation.
- Make sure the fork is oriented towards the mower for forward travel.

MODEL	FRONT TIRE SIZE
ZXS48/54	13 x 5 - 6

TIGHTENING TORQUE OF WHEEL BOLT (NUT)

20 ~ 25 N · m
(14.75 ~ 18.4 ft - lb)
(2.0 ~ 2.5 kgf · m)



REAR WHEEL



TIGHTENING TORQUE OF WHEEL BOLT (NUT)

120 N · m
(88.5 ft.- lb)
(12.2 kgf · m)

(1) Wheel Nut / Bolt

When replacing the rear wheel, tighten the nut with the following torque. After tightening, recheck the torque after operating for 10 minutes.

MODEL	REAR TIRE SIZE
ZXS48/54	23 x 10.5 - 12



MEMO





OPERATION

DECK	5-2
MOWER DECK INSTALLATION	5-2
MOWER DECK REMOVAL.....	5-4
OPERATING THE ENGINE	5-5
STARTING THE ENGINE	5-5
JUMP STARTING	5-7
STOPPING THE ENGINE.....	5-8
MOWER OPERATION	5-9
TIPS FOR BREAKING-IN	5-9
OPERATION	5-9
STOPPING.....	5-16
MOVING MOWER WHEN THE ENGINE IS STOPPED.....	5-16
PARKING	5-17
TOWING.....	5-18
TRANSPORTING	5-18
ADJUSTING THE CUTTING HEIGHT	5-19
OPERATING THE MOWER.....	5-20
BATTERY & FUSE LOCATIONS.....	5-21
HOW TO LIFT THE MOWER.....	5-22
CLEANING THE MOWER DECK.....	5-23
WASHING MOWER	5-23

5

5



DECK MOWER DECK INSTALLATION



(1) Deck Lift Lever



(1) Mower Deck



(1) Lift Link (2) Mounting Hardware

1. Push the deck lever all the way to the front of the unit (pushing against the helper spring) and use the deck pin to prevent the deck lever from springing back to the locked transport position.

2. Attach the deck with the hardware provided with the mower. (Be sure to rotate the wheel fork assemblies so they face away from the deck. This is the same direction when the mower is traveling in reverse and the wheels are trailing the mower.)

3. Place 3" and 3.25" blocks underneath the deck and set the deck pin to 3". Then lower the deck and adjust the rake and level.

CAUTION

- **Before mounting the mower deck:**
 1. Park mower on a level surface
 2. Turn engine off
 3. Apply the parking brake
 4. Set the PTO lever to the OFF position.

Pull the deck pin and lock the deck lever in transport mode.



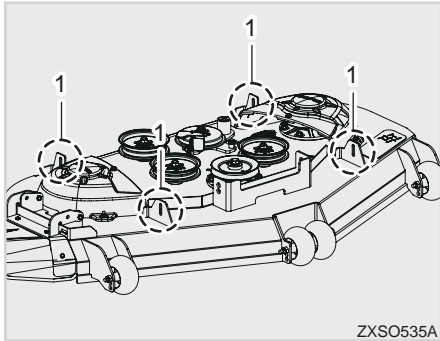

ZXS0535A

(1) Lifting Position

⊕ IMPORTANT

- **When attaching the mower deck, make sure to level the deck from right to left and rake the deck from front to rear.**

4. Raise the discharge chute and rotate the right blade so the cutting edge faces forward. Confirm that the blade tip is set to 3" (+/- 1/16")

To achieve the 3" blade height, the deck may need to be placed on blocks or other supports.

5. Repeat step 4 for the left side of the deck
6. Once the deck height is confirmed at 3", install the deck lift chains with the mounting hardware provided with the mower.

TIGHTENING TORQUE

59 ~ 69 N · m
(43 ~ 51 ft · lb)
(6 ~ 7 kgf · m)

7. Raise the deck 2-3 times and confirm operation is correct. Reset the deck to 3" cutting height. Confirm the right blade and left blades are rotated with the cutting edge facing forward. Re-measure and confirm the height of the front cutting edge of each side blade is 3" (+/- 1/16")

8. To adjust the side to side or front to rear (RAKE) height of the deck, you will need to make adjustments to each corner of the deck. To make adjustments, locate the adjuster mounted at the top of each deck lift support. There is one adjuster located at each corner or lifting position on the deck, four (4) in total.

9. Now measure the back cutting edge of each blade. The cutting height should measure between 1/8" & 1/4" higher than the front cutting edge (RAKE).

10. Once the side to side cutting height and front to rear cutting height (RAKE) have been confirmed, the deck is ready to cut.

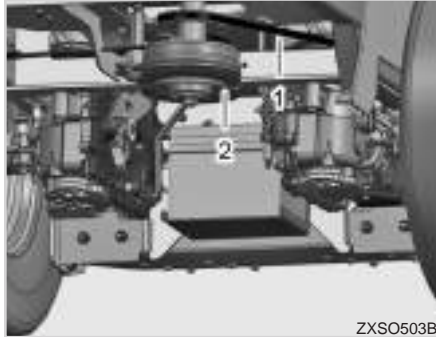

(1) PTO Belt (2) Engine Pulley

MOWER DECK REMOVAL

To remove the mower deck follow these quick steps:

1. Place the mower on a flat, level surface, engage the parking brake, turn the engine off and remove the key.
2. Remove the deck drive belt from the PTO clutch.
3. Be sure to rotate the wheel fork assemblies so they face away from the deck. This is the same direction when the mower is traveling in reverse and the wheels are trailing the mower.
4. Lower the deck till it sits on the ground.
5. Use the deck pin to prevent the deck lever from pulling back from the helper spring.
6. Loosen and remove the deck mounting bolts at each corner of the deck (4)
7. Remove the front deck mounting bolts that secure the deck to the frame (2).

8. Slide the deck out from under the mower on the right side.

12. After installing and adjusting the mower deck, be sure to connect the mower deck belt. Be sure to follow the routing guide provided on 6-27.



OPERATING THE ENGINE STARTING THE ENGINE



(1) Parking Brake Lever
(A) Engage (B) Disengage

1. Apply the parking brake.

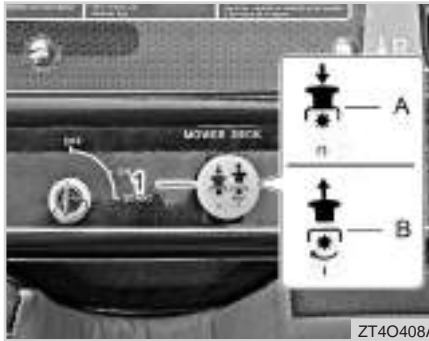

(1) PTO Switch
(A) Disengage (B) Engage

2. Check that the PTO switch is in the "OFF" position.

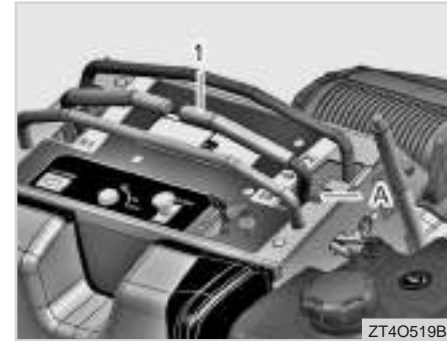

(1) RH Steering Lever
(A) Neutral Lock

3. Make sure the right steering lever is in the neutral lock position.



(1) Key Switch
(A) OFF (B) ON (C) START

4. Turn the ignition key clockwise to start the engine. Release the key when the engine starts.

⊕ IMPORTANT

- Engine start-up will only occur when the PTO switch is in the off position and the parking brake is engaged.

5. Warm up the engine at a fast idle for 2-3 minutes before performing work during the spring and fall.

<Starting up>

To protect the battery and the starting device, never turn the ignition on for more than 10 seconds.

<Warming up during cold weather >

It is recommended always to warm up the engine for about 5 minutes before driving in order to maintain the durability of the engine. Before warming up the engine, make sure that each part in the engine is properly lubricated.

⊕ IMPORTANT

- Always confirm the engine oil is at the proper operating level before starting the engine.

⚠ WARNING

- Place both feet on the platform (foot board) and make sure that the steering levers are in the "neutral" position and the parking brake is engaged. Also make sure that the PTO switch is in the "OFF" position.
- Do not start the engine without placing both feet on the platform or try to start the engine by crossing the starter solenoid terminals or try to start the engine by altering the safety switches. Attempting to alter the normal starting circuit could lead to sudden movement of the machine or cause injury.
- If you are driving indoors, be sure to provide adequate ventilation. If ventilation is insufficient carbon monoxide poisoning may happen due to exhaust gas.

**⚠ CAUTION**

- **DO NOT USE STARTING FLUIDS.** The use of starting fluids in the air intake system can be explosive and/or cause an engine runaway situation that could result in engine damage and personal injury.

While driving, pay attention to the operation and performance of the mower. Stop the engine immediately if any of the following occur.

- If the RPM suddenly falls or rises
- When suddenly making strange noises
- When the exhaust gas suddenly comes out black

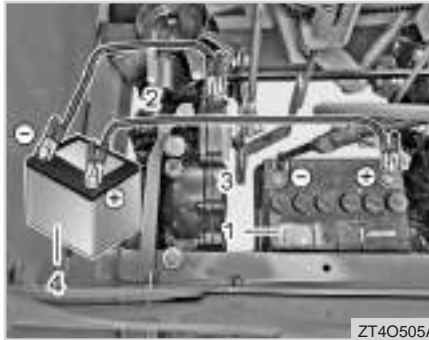
JUMP STARTING

- (1) Dead Battery (2) Jumper Cables (-)
(3) Jumper Cables (+) (4) Helper Battery

If the battery becomes discharged and the mower will not start, it is possible to jump-start the discharged battery with one from a working mower, spare battery or a jump pack.

Pull the cushion pad of the platform upwards and outward to remove the cushion pad from the mower and gain access to the battery.

1. Make sure that the battery used to jump start the discharged one

matches in voltage. Use only a 12 volt battery for this mower.

2. Check the length of the jumper cable and position another mower near the mower with the discharged battery.

Then, put all the shift levers in the neutral position, apply the parking brake, and stop the engine.

3. Wear protective glasses and gloves. Wear protective glasses and gloves and remove the cushion pad of the "jumper" mower, then remove the battery terminal cover as necessary.
4. Connect the alligator clips on both ends of the red positive cable to the positive terminals of both batteries.
5. Connect one clip of the black negative cable to the negative terminal of the jumper battery and the other clip to the mower negative terminal on the mower with the discharged battery.

6. Start the engine of the mower with jumper.
7. Start the engine of the mower with the discharged battery.
8. Disconnect the black cable from the negative battery terminals of both of the mowers.
9. Disconnect the red cable from the positive (+) battery terminals of both mowers.
10. Run the engine for at least 30 minutes to charge the discharged battery.
11. If the battery is discharged again, replace it or check the charging system.

⊕ IMPORTANT

- **When connecting the cables, make sure that the (+) and (-) terminals of the jumper cables do not contact each other as arcing may occur.**
- **Do not allow cables to get caught in moving parts.**

STOPPING THE ENGINE



(1) Key Switch
(A) OFF (B) ON (C) START

1. Place the throttle lever in the "Slow speed" position and leave at idle state.
2. Ensure the PTO is in the OFF position, raise the mower deck, engage the parking brake, then turn the ignition switch to the off position. Make sure the engine has stopped before stepping off the platform.

⊕ IMPORTANT

- **Do not stop the engine when the machine is on a slope for an extended period. Engine oil can enter the carburetor or exhaust if left unattended for an extended period of time leading to poor performance or engine damage.**
- **Always return the throttle to the slow (idle) position before turning the engine off to help prevent backfiring when the engine is stopped.**



MOWER OPERATION TIPS FOR BREAKING-IN

New mower break in should occur gradually over the first 5-15 hours of use. During the initial break-in period, be sure to follow the recommended guidelines below:

1. Start the engine and idle the engine at a low speed for 3 to 4 minutes in advance of work.
2. Increase the idling time in cold weather.
3. Do not overload the engine or lug it excessively. If cutting tall or overgrown grass, slow the ground speed to prevent overloading or lugging the engine excessively.
4. Idle the engine at a low speed for 2 to 3 minutes before stopping it.

WARNING

- ***On a slope, when the engine stops, immediately apply the parking brake so that the unit does not move.***
- ***Never allow passengers or anyone on the mower other than the operator.***
- ***Do not drive in ditches or other places that are likely to collapse.***
- ***Avoid sudden acceleration and sudden stopping, and be sure to operate at reduced speeds when turning.***
- ***When backing up, make sure that there are no people or obstacles around you.***

OPERATION

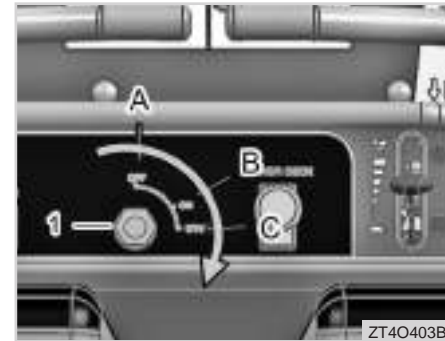

(1) Key Switch

(A) OFF

(B) ON

(C) START

5

1. Start the engine according to the engine start-up procedure. (Outlined in pages 5-4 through 5-6.)



5-10 ZXS SERIES MOWER



(1) Cutting Height Handle
(A) Pull

2. With the cutting height handle in the “locked” position, set the cutting height by placing the pin in the desired height position. Once the pin is in position, pull back slightly on the handle & depress the release tab on the top of the handle. Lower the handle until it rests against the cutting height pin.

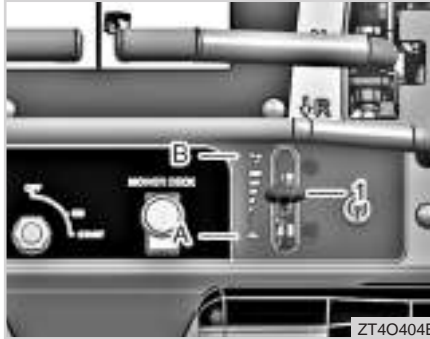

(1) Throttle Lever
(A) 🐮 : Low Speed (B) 🐎 : High Speed

3. Use the throttle lever to slowly accelerate the engine speed from idle to medium speed.

⊕ IMPORTANT

- When operating, set the throttle lever to “medium speed” or higher and do not operate at low speed.



(1) Parking Brake Lever
(A) Engaged (B) Disengaged

4. Hold the right steering lever in position and push the parking brake lever forward to release the brake.

⚠ WARNING

- Do not park on steep slopes with the engine running under any circumstances. It can cause serious accidents.

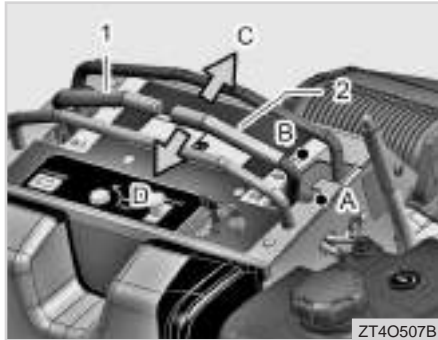

(1) LH Steering Levers (2) RH Steering Levers
 (A) Neutral Lock (B) Neutral
 (C) Forward (D) Reverse

5. The steering levers control the mowers direction of travel and speed. The levers can be used together to initiate direction, turns, acceleration/speed and braking depending on terrain and field conditions. The RH steering lever must be depressed at all times when the parking brake is released to keep the engine running.



(1) LH Steering Levers (2) RH Steering Levers
 (A) Forward

► MOVING FORWARD

Push both steering levers forward evenly to move the machine forward. Push the steering levers forward further to increase speed, reduce force to allow the leavers to move rearward to decrease speed. Return the levers to neutral to stop the mower.



(1) LH Steering Levers (2) RH Steering Levers
 (A) Reverse

► MOVING REVERSE

Pull both steering levers backward evenly to reverse the machine. Pull the levers backward further to increase the reverse speed, reduce force to allow the leavers to move forward to decrease speed. Return the levers to neutral to stop the mower.

⚠ WARNING

- **Be sure to turn the PTO off before reversing the mower. Do not mow while traveling in the reverse direction as serious injury could occur.**

⊕ IMPORTANT

- **Contact your authorized KIOTI Dealer for service should the mower not track straight on smooth, level ground when the steering levers are in the full forward or rearward position**

📖 NOTE

- Return springs are installed on both steering levers. You can feel the spring tension when you move the levers. Reducing the amount of force exerted against the levers to allow the spring tension to return the levers to neutral. (Do not remove hands from drive levers while releasing the levers though.)
- To turn the mower, move one lever in the forward direction and the other lever in the reverse direction. Caution and slow lever movements should be used when learning the operational characteristics of the mower to prevent harsh or erratic operation.

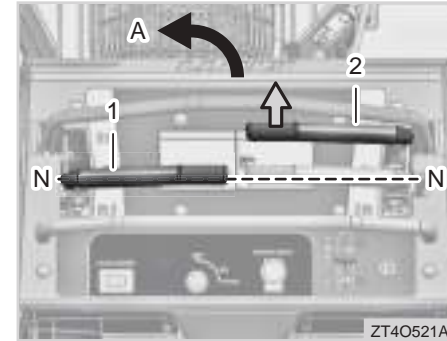

- (1) LH Steering Levers
- (2) RH Steering Levers
- (A) Forward Left Turn

▶ FORWARD LEFT TURN

When the right steering lever is pushed further forward than the left steering lever, the Mower makes a forward left turn.

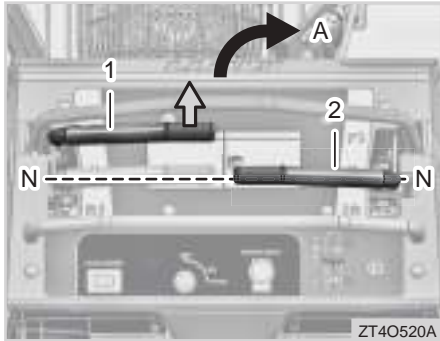

- (1) LH Steering Levers
- (2) RH Steering Levers
- (A) Forward Right Turn

► FORWARD RIGHT TURN

When the left steering lever is pushed further forward than the right steering lever, the Mower makes a forward right turn.

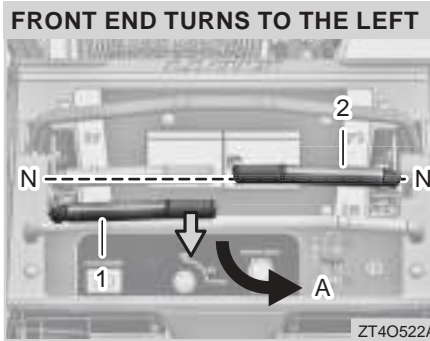

- (1) LH Steering Levers
- (2) RH Steering Levers
- (A) Reverse Right Turn

► REVERSE RIGHT TURN

When the left steering lever is pulled further rearward than the right steering lever, the Mower makes a reverse right turn.

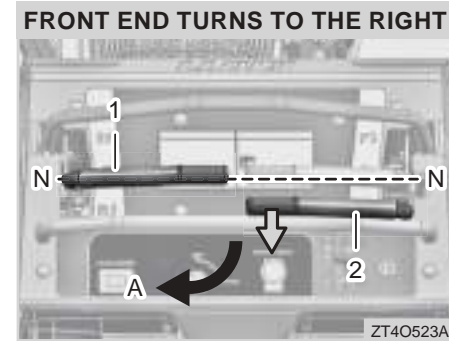

- (1) LH Steering Levers
- (2) RH Steering Levers
- (A) Reverse Left Turn

► REVERSE LEFT TURN

When the right steering lever is pulled further rearward than the left steering lever, the Mower makes a reverse left turn.

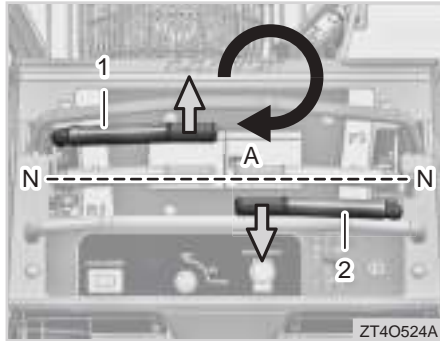

(1) LH Steering Levers
(2) RH Steering Levers
(A) Right Zero Turn

► **RIGHT ZERO TURN**

Push the left lever forward and pull the right lever back at the same time to rotate the machine to the right (clockwise) with zero turning radius.

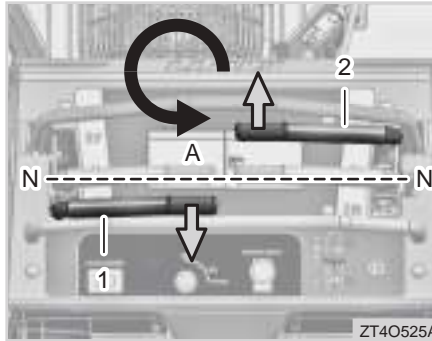

(1) LH Steering Levers
(2) RH Steering Levers
(A) Left Zero Turn

► **LEFT ZERO TURN**

Push the right lever forward and pull the left lever back at the same time to rotate the machine to the left (counter-clockwise) with zero turning radius.

⊕ IMPORTANT

- Do not make sharp turns or perform zero-turns at high speed as the operator can be thrown from the machine.
- Damage to turf can occur when performing a zero-turn.
- It is recommended turn the PTO off before performing a zero-turn to reduce the risk of flying debris should turf damage occur.



RESTARTING ON A SLOPE

When you need to restart after stopping on a slope, follow the procedure below.

1. Engage the parking brake so that the machine does not move, and start the engine.
2. Set the throttle lever to "medium speed".
3. Release the parking brake.
4. Move the machine slowly and carefully by operating the steering levers.
5. This mower is designed for traction and stability under normal, dry mowing conditions. Caution should be used when traveling on slopes, especially if the grass is wet. Wet grass reduces traction and steering control.
6. Stay two cut widths (width of the mower deck) away from ditches, slopes and drop-offs.
7. To prevent loss of control and roll over situations, do not start or stop quickly, avoid unnecessary turns

and travel at a slow speed. If loss of traction occurs, disengage the PTO and proceed slowly off of the slope.

8. Avoid sudden starts when driving uphill. This may cause the machine to tip back-wards.
9. Be careful when traveling down hill. The machine weight will transfer to the front of the machine, causing the drive wheels to slip and loose braking or steering control.
10. Do not drive on slopes greater than 15 degrees.
11. Control of the machine sliding on a slope will not be regained by application of the parking brake.

WARNING

- ***DO NOT operate this mower on steep slopes. To check if the slope is too steep, attempt to back the mower up the edge of the slope with the mower deck in the down position. If the wheels do not slip or loose traction, proceed a slow as possible with extreme caution.***

CAUTION

- **Loss of control on a slope could occur if:**
 - You start or stop suddenly
 - Travel speed is too fast
 - Change directions quickly
- **Pay special attention when working on or near slopes to prevent loss of control or rollover of the mower.**

STOPPING

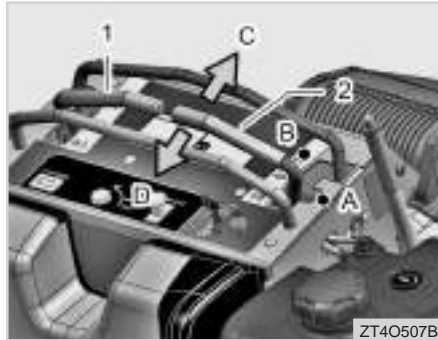

(1) LH Steering Levers (2) RH Steering Levers
 (A) Neutral Lock (B) Forward
 (C) Neutral (D) Reverse

Under normal conditions, when the steering levers are returned to the neutral position, the mower will stop.

1. Stop the machine by moving both steering levers to the "neutral" position.
2. Engage the parking brake.
3. Move the throttle lever to the idle speed position and set the PTO switch to "OFF".
4. Stop the engine.

MOVING MOWER WHEN THE ENGINE IS STOPPED

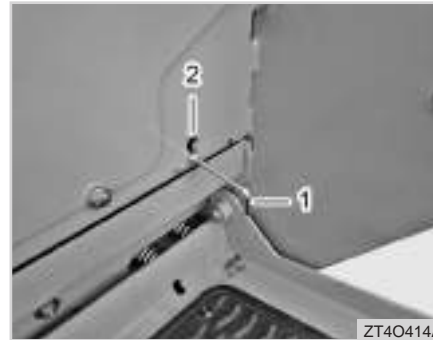

(1) Bypass Control Rod (2) Opening

To move the mower when the engine is off, locate the transaxle bypass control rods for both the LH and RH sides. The bypass control rods are located in LH and RH corners of the operator station, below the cushion pad.

Before opening the bypass valve, make sure the parking brake is engaged to prevent the mower from accidentally moving.

To open the bypass control valve, gently raise the bypass control rod and pull it rearward allowing the "rod stop" to pass through the large opening in the frame. Once out, gently lower the "rod stop" into the slot making sure the "rod stop" is resting in the slot outside of the frame. When released, the rod should not move forward and remain in the open position.

Repeat for the opposite axle.

With both bypass control valves open, the mower can be rolled once the parking brake has been released. Once the mower has been placed in its desired location, re-engage the park brake.

To close the bypass control valve, gently raise the bypass control rod and push it inward allowing the "rod stop" to pass through the large opening in the frame. Once in, gently lower the "rod stop" into the slot



PARKING

making sure the “rod stop” is resting in the slot in front of the frame. When released, the rod should not move rearward and remain in the closed position.

Repeat for the opposite axle.



(1) Chocks

If you need to park on a slope, place chocks behind the wheels so that the machine cannot roll down the slope.

1. Stop movement of the mower by positioning the steering levers to the Neutral position.
2. Pull the parking brake lever to engage the parking brake and turn the PTO switch to “OFF”.
3. Back to lower the engine speed to idle.

4. Turn the ignition key to the “OFF” position to stop the engine.



CAUTION

- **Make sure the mower is completely stopped and that the parking brake is securely engaged, and then get off the mower.**
- **Do not park on dry hay, straw or debris. Contact with a hot muffler could lead to a fire.**
- **Loose material under the wheels when stopped or parked could lead to accidental mower movement due to loss of traction.**

5. Install chocks around the rear tires to prevent accidental mower movement.

TOWING

This mower is not designed to tow or haul and does not come with a hitch nor is it designed to have a hitch installed.

TRANSPORTING

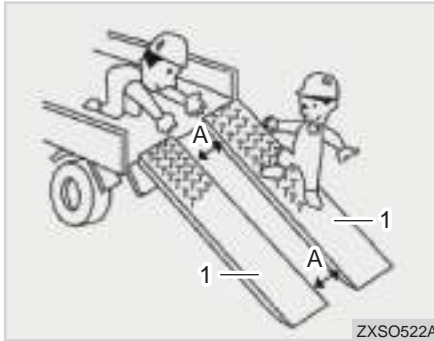

(1) Loading Ramp
(A) Parallel

- 1 When loading the mower on a truck or trailer, be sure to use ramps designed to safely handle the weight of the mower. Be sure the ramps are wider than the rear tires of the mower.
2. Always secure the ramps to the transporting vehicle to minimize the opportunity for the ramps to fall or detach from the hauling equipment.
- 3 Raise the deck and lock it in the transport position

- 4 It is recommended to load in reverse and unload in forward if possible to minimize the opportunity for the mower to raise the front wheels off the ramps and become difficult to control.
- 5 If the rear wheels begin to spin while loading, the ramp angle is too steep. Drive the mower back down and reposition the ramps to decrease the loading angle if possible.
- 6 When loading/unloading, operate the mower slowly as equipment or operators could be hurt in the event of a rollover or loss of control.
- 7 Once loaded, engage the parking brake and turn the engine off before dismounting from the machine.

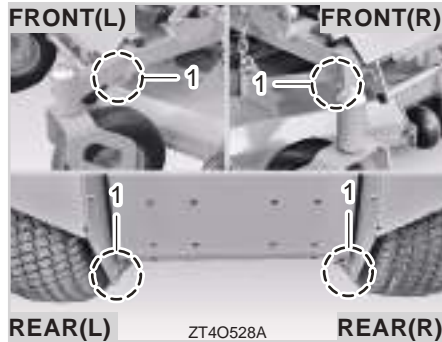

(1) The front and rear securing points

8 Securely fasten the mower to the transporting vehicle with straps or chains. Be sure to utilize the front and rear securing points designed into the mower (see attached picture).

⚠ CAUTION

- Do not tow this unit as it may damage the transaxle.
- Make sure that the Vehicle you are using to transport with has all the lighting and markings required by law.

ADJUSTING THE CUTTING HEIGHT



(1) Cutting Height Handle
(A) Transport or "Locked" position

1. Before operating the mower, be sure the air pressure in the front and rear tires are within their recommended operating range.
2. To set the cutting height, pull the cutting height handle and lock the deck in the transport or "locked" position.



OPERATING THE MOWER



ZT4O413A

(1) Cutting Height Pin

- Place the cutting height pin the hole corresponding with the desired height of cut. Then lower the cutting height handle till it rests against the cutting height pin.

Familiarize yourself with the type of grass or lawns you will be mowing. In the summer months especially, lawns may be damaged when cut too low.

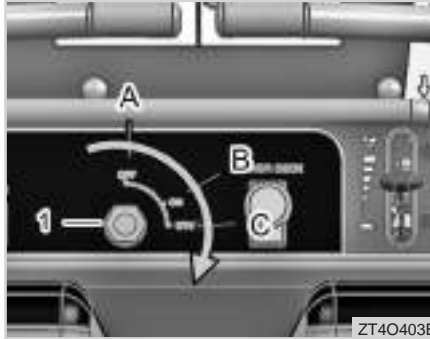

ZT4O403B

(1) Key Switch
(A) OFF (B) ON (C) START

- Start the engine with the throttle set to low.
- Set the throttle to medium and with the park brake engaged and the right drive lever depressed, engage the PTO. If the right lever is not depressed, the mower will stop.
- Increase the throttle speed to wide open.
- Release the park brake.

- Using the techniques from 5-9 through 5-14 maneuver the mower to cut grass.

WARNING

- Never put hands into the discharge chute while the engine is running for any reason.
- If the mower discharge becomes clogged, ensure the engine is off, the steering levers are in neutral, the parking brake is set and the engine/blades have come to a complete stop before dismantling the machine to clear the discharge.

IMPORTANT

- Clean the fan and screens to prevent the engine from overheating.

**⊕ IMPORTANT**

- Always set the throttle lever to the “high” position for the best cutting performance.
- If the area to be cut is very overgrown, cut with the deck in the highest position on the first pass, then cut again at the desired height.
- If the mower travel speed is too fast or the blade speed drops due to engine overloading from over grown or dense areas, the grass will not be cut clean.
- When not mowing, set the PTO switch to the “OFF” position and place the deck in the transport or “lock” position. If the RPM begins to decrease while working, lower the driving speed in order to maintain the same blade speed.

BATTERY & FUSE LOCATIONS

(1) Rider Platform Cushion Pad (2) Battery
(A) Pull Up

To reinstall, align the tabs on the back of the pad into the slots in the mower frame. Push downward on the pad the removed.

⚠ CAUTION

- Be careful not to pinch your fingers when removing or reinstalling the cushion pad from the mower frame.

To access the battery and fuse panel:

1. Park the mower on level ground. Make sure the PTO is off, the engine is off, the parking brake is set and the key has been removed from the ignition.
2. At the rear of the mower, lift the cushion pad upward and pull back gently to remove it from the mower frame.

HOW TO LIFT THE MOWER

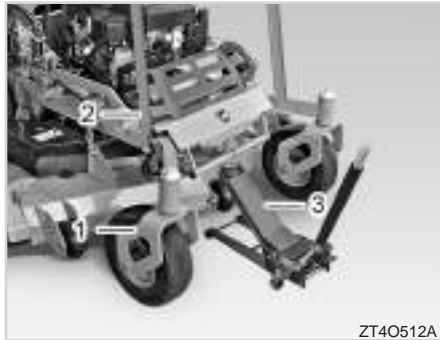

(1) Cast Support Assembly (2) Rope
(3) Jack

1. The mower must be lifted for maintenance including blade removal, debris removal, front wheel removal.
2. When lifting the front of the mower, you can lift the cast support assembly with tow strap, rated for the weight of the mower or position a jack underneath the crossbar that supports the front deck trail arms as shown.

Once raised, support the unit by placing jack stands underneath the frame directly behind the front wheel forks.

⚠ CAUTION

- Do not work under a mower that is not firmly supported with jack stands.
- To prevent accidental movement of the machine, make sure the parking brake is engaged and rear wheels are chocked before lifting or performing any work.



(1) Rear Bumper (2) Strap
(3) Jack

3. When lifting the rear of the mower, lift the rear frame with an approved lifting strap attached to a hoist or a jack.



CLEANING THE MOWER DECK

1. Be sure the engine is off, the parking brake is set and the key has been removed from the ignition switch.

Daily mower cleaning can be performed by wiping away debris or using compressed air.

Follow the recommended procedure outlined on P 5-20 for lifting the mower to gain better access underneath the deck.

Clean underneath the deck with compressed air or water.

When using a pressure washer, be sure to keep the nozzle a minimum of 8 feet away from the mower surface at all times. Pressurized water sprayed at a close distance can cause personal injury or damage to the mower's paint, electrical or mechanical systems.

Always be sure to wear proper eye protection when using pressurized water to clean and eye + ear protection when using pressurized air to clean your mower.

CAUTION

- Always inspect the area surrounding the mower to be sure no hoses, tools or foreign objects are underneath or in the mower's path before starting the engine
- Before starting the engine, place the throttle lever at idle, make sure the PTO is off and the parking brake is engaged.

WASHING MOWER

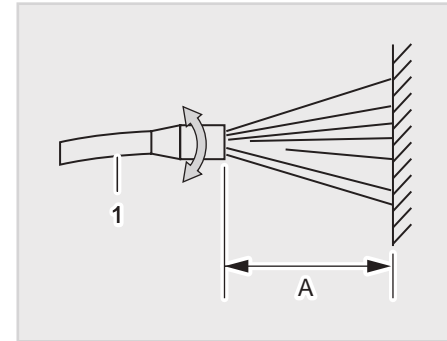

(1) High-pressure Washer
(A) At least 8 feet

When cleaning with high pressure water, always be mindful of the following:

1. Electrical Parts and wiring harnesses: Water intrusion can cause shorts in the electrical system. Which could lead to wire harness malfunction, electrical component failure or eventually fire.
2. Hoses: Do not apply direct water



pressure to hoses, fuel lines, etc. Hoses subjected to high pressure water could come loose, break or be damaged resulting in fluid loss or fire.

3. Moving Mechanical Parts: Direct high pressure water to the engine and drive parts can cause malfunction and damage.

 **WARNING**

- ***DO NOT wash a hot or running engine. Cold water could damage the engine. Use compressed air to clean the engine if it is still hot or wait until the engine is cool before washing. Always use proper eye and ear protection when using compressed air or eye protection with water.***



MAINTENANCE

RECOMMENDED MAINTENANCE SCHEDULES 6-3

LUBRICANTS 6-5

DAILY CHECKS 6-6

 GENERAL INFORMATION 6-6

 CHECKING ENGINE OIL LEVEL 6-6

 CHECKING AND ADDING FUEL 6-7

 CHECKING AND CLEANING THE AIR INTAKE SCREEN 6-9

 CHECKING THE TRANSAXLE FLUID LEVEL.... 6-9

 LUBRICATION 6-10

EVERY 50 HOURS 6-11

 AIR FILTER MAINTENANCE 6-11

EVERY 100 HOURS 6-12

 CHANGING THE ENGINE OIL AND FILTER... 6-12

 CHECKING THE SPARK PLUGS 6-13

 CHECKING THE FUEL LINES/FUEL FILTER 6-13

 ADJUSTING TRANSAXLE DRIVE BELT TENSION 6-14

 CHECKING THE PARKING BRAKE 6-16

 CHECKING AND CHARGING THE BATTERY 6-17

 CLEANING THE ENGINE SHROUD 6-19

EVERY 200 HOURS 6-19

 REPLACING ENGINE OIL FILTER 6-19

 REPLACING TRANSAXLE OIL AND FILTER ... 6-19

EVERY 400 HOURS 6-21

 REPLACING THE FUEL FILTER 6-21

EVERY 500 HOURS 6-22

 ADJUSTING THE PTO CLUTCH 6-22

EVERY 1 YEAR 6-24

 REPLACING AIR CLEANER ELEMENT 6-24

 CHECKING THE SPARK PLUGS 6-25

SERVICE AS REQUIRED 6-26

 REPLACING FUSES 6-26

 CHECKING BLADES 6-26

 INSPECTION AND SHARPENING BLADES.. 6-27

6



MAINTENANCE

REPLACING BLADES 6-28

REPLACING MOWER BELT 6-29

ADJUSTING BELT TENSION..... 6-30

CONTROLS DAMPER ADJUSTMENT 6-30

ADJUSTING ANTI-SCALP ROLLERS 6-31

ADJUSTING DECK LEVEL (SIDE TO SIDE) .. 6-32

ADJUSTING DECK RAKE (FRONT TO REAR) 6-33

HYDROSTAT TRANSAXLE ADJUSTMENT ... 6-34



RECOMMENDED MAINTENANCE SCHEDULES

To prevent accidents, breakdowns and keep your mower in good working condition; regular inspections and maintenance are required.

MAINTENANCE SERVICE INTERVAL	MAINTENANCE PROCEDURE
1. Before each use or daily	• Check the engine oil level.
	• Check for bent or damaged mower blades.
	• Check the safety interlock system.
	• Check for loose hardware.
	• Clean the engine and exhaust system area.
	• Clean the hydro fan cooling guards, hydro cooling fins, and fan.
	• Clean the grass and debris build-up from the machine and cutting deck.
	• Clean the grass build-up from under the cutting deck.
2. After the first 50 hours	• Inspect deck hanger, spindle cover and drain chute.
	• Change the engine oil.
3. Every 50 hours	• Check the air cleaner filter.
	• Check the tire pressures.
	• Check the condition of the belts.
	• Inspect deck hanger, spindle cover and drain chute.
	• Replace the primary air cleaner element - check secondary air cleaner element; replace if dirty.



MAINTENANCE SERVICE INTERVAL	MAINTENANCE PROCEDURE
4. After the first 100 hours	<ul style="list-style-type: none"> • Check the wheel hub slotted nut torque specifications. • Check the wheel lug nuts. • Check the park brake adjustment .
5. Every 100 hours	<ul style="list-style-type: none"> • Change the engine oil. • Lubricate the deck lift pivots. • Remove the engine shrouds and clean the cooling fins. • Check the spark plugs.
6. Every 200 hours	<ul style="list-style-type: none"> • Replace the engine oil filter. • Replace the transaxle oil and filter.
7. Every 500 hours	<ul style="list-style-type: none"> • Replace the secondary air cleaner element • Change the hydraulic filter and fluid. (Every 250 hours if using Mobil 1 15WSO) • Check the wheel hub slotted nut torque specifications . • Check the wheel lug nuts. • Check the park brake adjustment.
8. Yearly	<ul style="list-style-type: none"> • Grease the deck and pump idler pivots. • Grease the front caster pivots.

⊕ IMPORTANT

- **Air cleaner should be cleaned more often in dusty conditions than in normal condition.**
- **Do not repair or replace components with parts other than Genuine KIOTI Parts. Your Authorized KIOTI Dealer should be your first source for parts and repairs.**



LUBRICANTS

To keep your mower in top operating condition, use only genuine **KIOTI** fluids, oils and greases or equivalents.

NO.	ITEM	CAPACITY	LUBRICANTS
1	Fuel	7.0 U.S.gal.	Unleaded gasoline 87 octane or higher
2	Engine oil	1.92 U.S quart	Engine oil : API service Classification SG, SH, SJ or higher Above 10 °C (50 °F)... SAE 30 Between -18 °C(0 °F) TO 38 °C (100 °F)... SAE 10W - 30 Below 0 °C (32 °F)... SAE 5W - 30
3	Transaxle fluid	5.6 U.S quart	Engine oil : API service Classification SL SAE20W-50
4	Grease	Appropriate amount if necessary	SAE Multi-Purpose Type Grease

※ Oil capacity when the oil is at the maximum fill level of the dipstick

WARNING

- **Check the oil level daily before operating the mower. Always keep the oil level between the minimum and maximum levels on the dipstick. Correct the oil level, if needed, before operating.**
- **Always check and add oil with the mower on a flat, level surface.**



DAILY CHECKS GENERAL INFORMATION

It is a good practice to know the condition of your mower before you start it. You should perform a routine check daily, before each use.

1. Inspect any issues detected during the previous day's operation. Be sure to make any repairs to broken or damaged items before using the mower.
2. Perform a pre-operation check by walking around the machine, looking for the following:
 - Loose bolts or nuts
 - Loose mower deck mounts
 - Any damage or deformation of the body
 - Oil or fluid leakage
 - Torn or frayed belts
 - Bent, broken or damaged blades
 - Damaged or under-inflated tires
 - Damaged or missing safety equipment including safety shields, decals, switches, etc.

For detailed information, refer to the recommended maintenance schedules in this chapter.

CAUTION

- **Before inspecting or working on any mower, place the mower on a flat, level surface, make sure the PTO is off, the parking brake is engaged and the engine is turned off with the key removed from the ignition.**
- **If fuel or fluid spills, clean it thoroughly.**
- **The battery, wiring, muffler or surrounding areas of the engine can catch on fire if there is debris or spilled fuel present. Check and clean as needed.**
- **Never perform an engine inspection on a running engine or an engine that is still hot from operation. Failure to comply could lead to serious injury including cuts, abrasions, burns, etc.**

CHECKING ENGINE OIL LEVEL



(1) Oil filler neck & Dipstick

1. Check the engine oil daily.
2. Park the mower on a level surface, engage the parking brake, turn the engine off and lower the mower deck to the ground.
3. If the engine was just running, wait for approx. 5 minutes before checking the oil level.



**CAUTION**

To avoid injury:

- Be sure to set the parking brake and stop the engine before checking the oil level.

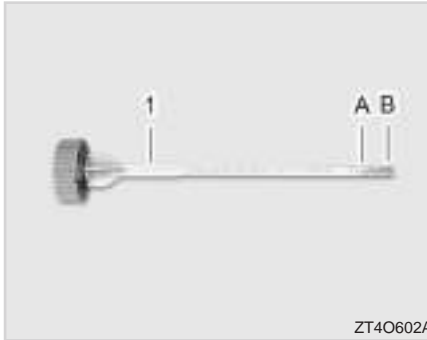

(1) Oil Dipstick
 (A) Upper Limit (B) Lower Limit

4. Pull out the oil dipstick, clean it, and then insert it into its original position. Next, remove the dipstick and check if the oil level is within the specified range.
5. If the oil level is too low, add new oil so that the level is within the allowable range.

CHECKING AND ADDING FUEL

(1) Fuel Tank Cap (2) Fuel Tank

The fuel tank is located on the right side of the mower.

Only use unleaded gasoline 87 octane or higher.



(1) Fuel Gauge
(A) Empty (B) Full

1. Check the fuel level by visually referencing the fuel gauge.
2. If the fuel level is low, open the fuel tank filler cap and add fuel.
3. When refueling is completed, re-install the fuel cap and turn the cap clockwise until it ratchets and makes a clicking sound.

⚠ DANGER

- **Never fuel a hot mower!**
- **Fuel in the fuel tank can become pressurized. Open fuel cap slowly in a well ventilated area, wait for pressure to be released to avoid serious or fatal injury from discharged spraying fuel. No smoking or open flames.**
- **Never remove the fuel cap or refuel near open flames or cigarettes.**
- **To avoid injury from burns, allow the mower to cool before removing the fuel tank cap and refueling.**

⚠ CAUTION

To avoid personal injury:

- Do not smoke while refueling.
- Only add fuel in a well-ventilated area.
- Be sure to stop the engine before refueling.
- Refuel through a filter if required to prevent the introduction of contaminants into the fuel tank.

**⊕ IMPORTANT**

- Be careful not to let the fuel tank become empty. Otherwise air will enter the fuel system, necessitating bleeding before the next engine start.
- Be careful not to spill fuel when re-fueling. Should a spill occur, clean the spill at once to prevent fires.
- If the mower is to be stored for 30 days or longer, the addition of a fuel stabilizer to the tank is recommended. Once applied, the engine should be operated for a period of 5-10 minutes at high idle to distribute the stabilizer throughout the fuel system.

CHECKING AND CLEANING THE AIR INTAKE SCREEN

(1) Air Intake Screen (2) Engine Shroud

Check the air intake screen and the air inlet daily for debris or foreign material that could reduce air intake. Dust or stains around the air intake screen, air inlet or around the engine cooling area will reduce cooling performance.

1. Make sure that the air intake is free of grass pieces and debris
2. If the screen is dirty, clean the screen with a brush or cloth.
3. Remove all dust and dirt from the engine shroud.

CHECKING THE TRANSAXLE FLUID LEVEL

(1) Oil Filler Neck

1. Park the mower on a level surface, turn the engine off, engage the parking brake and lower the mower deck.
2. Make sure the parking brake is set, set all shift levers into the neutral position.
3. Pull the transaxle dip stick and check the fluid level.
4. If the oil level is too low, add some new oil so that the level is within the allowable range.

⊕ IMPORTANT

- If the oil level drops too low, do not start the engine before bringing the oil level within the safe operating range.

LUBRICATION

Apply a high quality, multi-purpose grease to each of the locations shown here, at the recommend intervals below.

Be sure to record the date and hours each time maintenance is performed on the mower.

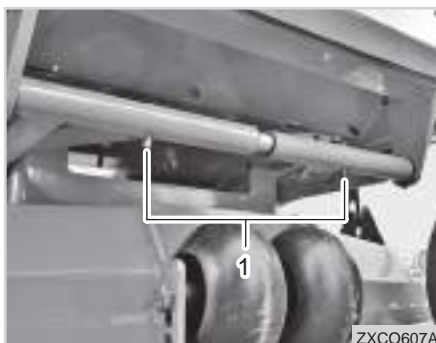

(1) Deck Front Link Pipe (LH/RH)

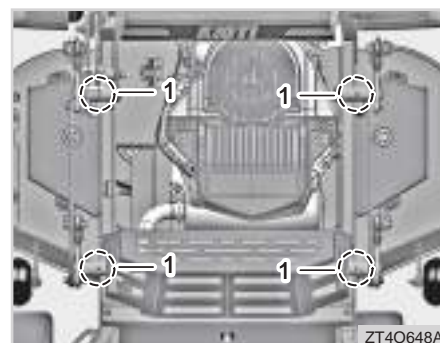

(1) Lift Hinge Pipe

1. Grease the places mentioned above. Use multipurpose high grade grease and record the running time when greasing.
2. Be sure to stop the mower, turn the PTO off, engage the parking brake, turn the engine off and remove the key from the ignition before performing any maintenance on the mower, including greasing.



EVERY 50 HOURS AIR FILTER MAINTENANCE

NOTE

Minimum recommend greasing intervals:

- For mowers operated daily: 1 time per week, minimum.
- For mower operated less frequently, every 25 hours, minimum.

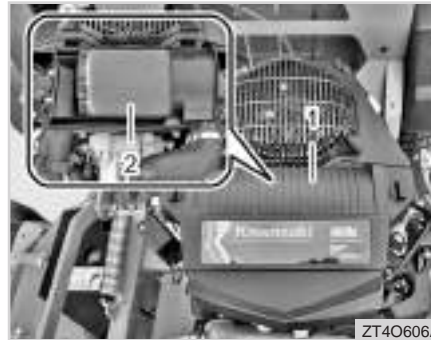

- (1) Air Cleaner Cover
(2) Primary Element

1. Open the air filter cover and remove the primary element and the secondary element.
2. The air filter uses a dry element. Never apply oil to the element.
3. To clean the filter, use clean dry compressed air on the inside of the filter. Air pressure at the nozzle must not exceed 2 kgf/cm² (29 psi). Maintain reasonable distance between the nozzle and the filter. Rotate the filter while blowing to

clean the entire filter area.
Re-install when finished.

IMPORTANT

- **The air cleaner should be inspected more frequently when the mower is operated in dry and dusty conditions.**
- **Never start the engine with the filter removed.**

EVERY 100 HOURS CHANGING THE ENGINE OIL AND FILTER

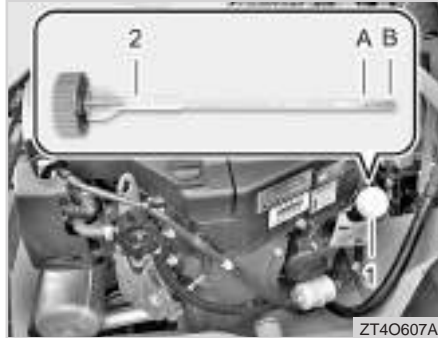

(1) Oil Filler Neck (2) Oil Dipstick
(A) Upper Limit (B) Lower Limit

1. Make sure the PTO is off and the parking brake is engaged, and start the engine to warm up. Operate the engine for approximately 10 minutes at a high idle.



(1) Extended Drain Hose & Plug

2. After the engine has warmed up, bring the engine down to idle, turn the engine off and remove the key from the ignition.
3. Place an oil pan under the engine and unscrew the drain plug counterclockwise to drain the oil completely. All the used oil can be drained out easily when the engine is still warm.
4. Unthread the dipstick and leave it sitting in the filler neck. This will

allow air to enter for a smooth and quick oil drain. Remove the oil filter and clean the filter base. Apply a thin film of oil to the new filter's o-ring. Thread the new filter on and tighten 3/4 turn after the o-ring makes contact with the filter base.

5. Install the drain plug.
6. Refill the engine oil to the specified amount through the oil filler neck and rethread the dipstick into the filler neck.

+ IMPORTANT

- **Only use oil that meets or exceeds the minimum engine manufacturer's requirements. Use only filters recommended by the engine manufacturer.**

ENGINE OIL SAE 10W-30

**⚠ WARNING**

- *Engine oil becomes hot during operation and can burn when contacting the skin.*
- *Be sure to wear approved eye protection and gloves when changing the engine oil to prevent contact with the eye or hands.*
- *Prolonged skin contact over an extended time with engine oil could lead to skin disorders or skin cancer. Use soap and warm water to wash thoroughly to remove oil from the skin.*
- *Keep used oil out of the reach of children. Be sure to dispose of oil through approved recycling centers or oil waste facilities.*

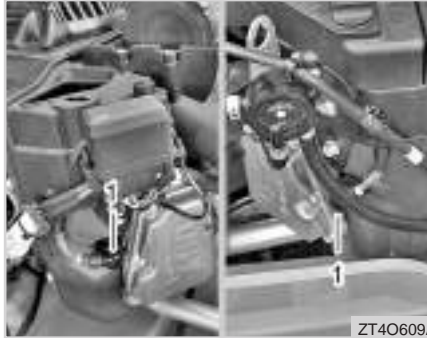
CHECKING THE SPARK PLUGS

(1) Spark plug (Both Sides)

Check the spark plugs condition and filament gap every 100 hours or replace every year, depending on use.

1. Remove the spark plug wire from the spark plug.
2. Remove the plug using a spark plug wrench socket with ratchet.
3. Check the spark plugs for cracks, wear and damage. Replace the spark plugs if necessary.

**CHECKING THE FUEL LINES/
FUEL FILTER**

(1) Pipe Clamp (2) Fuel Line
(3) Fuel Filter

1. The fuel line is made of rubber and could deteriorate if exposed to heat and sunlight over an extended period of time.
2. Inspect fuel lines for cracks, damage or leaks periodically. If required, replace the fuel line and clamps to prevent risk of fire or loss of performance.
3. Check the fuel filter frequently and replace it immediately if it is blocked by dust or dirt.

4. Contact you Authorized **KIOTI** Dealer for assistance with maintenance or to make repairs above your skill set or technical capabilities.

⚠ CAUTION

- **Before performing any inspections or maintenance, make sure the parking brake is engaged and the engine is turned off.**
- **Inspect the fuel lines regularly. The fuel lines are subject to wear and aging with time. Failure to perform periodic inspections may lead to a fuel leak. Fuel leaking on a hot engine could cause a fire.**

⊕ IMPORTANT

- **When disconnecting the fuel lines for replacement, plug both ends with cloth or paper to prevent dust or foreign material from entering it. Otherwise, the fuel pump or carburetor could be damaged.**

ADJUSTING TRANSAXLE DRIVE BELT TENSION

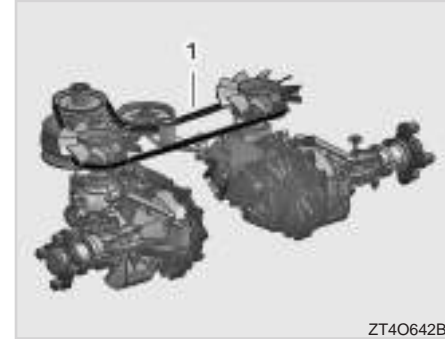

(1) Drive Belt

The transaxle drive belt is automatically adjusted by spring tension and does not need adjustment.

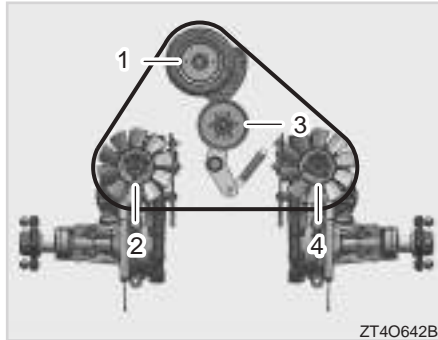
**MOUNTING AXLE BELT**

ZT4O642B

- (1) Pulley No. 1 (2) Pulley No. 2
 (3) Pulley No. 3 (4) Pulley No. 4

1. No. 1, 2 and 4 pulleys in the order as shown above.

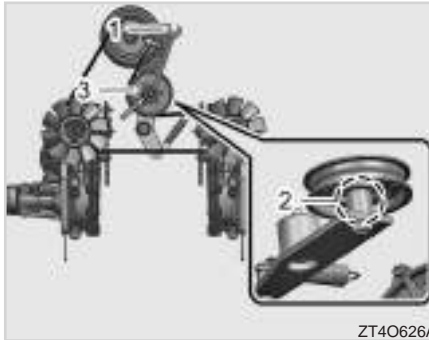

ZT4O626A

- (1) Spanner 17 mm (2) Spacer
 (3) Pulley No. 3

2. Using a Spanner (17 mm), hold the nut on the top of No. 3 pulley. Make sure the belt is on top or above the pulley and wrench. Move the wrench to stretch the spring and bring the tensioner pulley closer inline with pulley No. 1 and No. 4. Slide the belt over top of the pulley and align the belt in the groove. Release force on the wrench slowly and allow the tensioner pulley to tighten the belt.

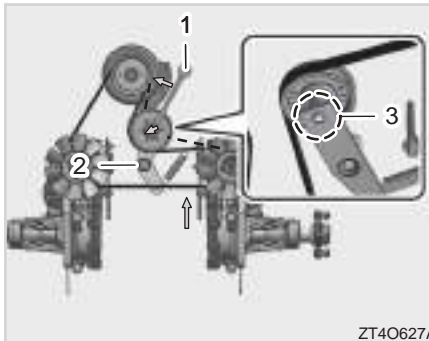

ZT4O627A

- (1) Spanner 14 mm (2) Bracket
 (3) Bolt

CHECKING THE PARKING BRAKE

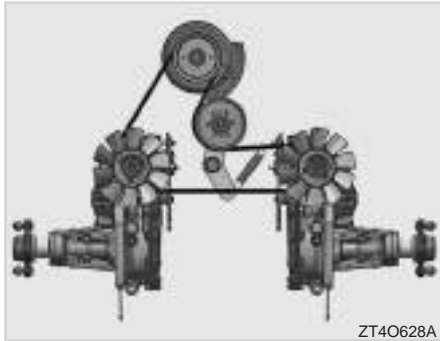

3. Make sure the axle belt path is correct and the belt is aligned in all pulleys correctly.

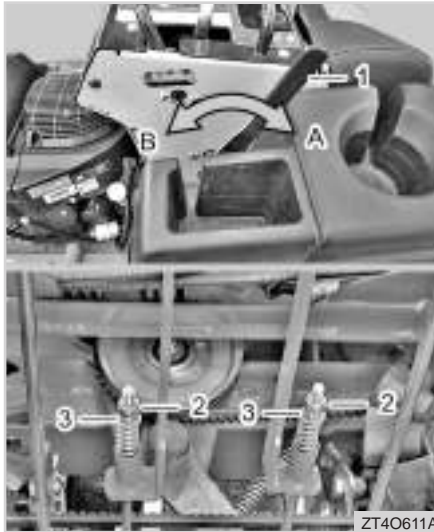

- (1) Parking Brake (2) Lock Nut
(3) Adjusting Nut
(A) Lock (B) Unlock

The parking brake linkage should be adjusted whenever the parking brake lever is placed in the “Engage” position and the parking brake will not prevent the mower from moving.

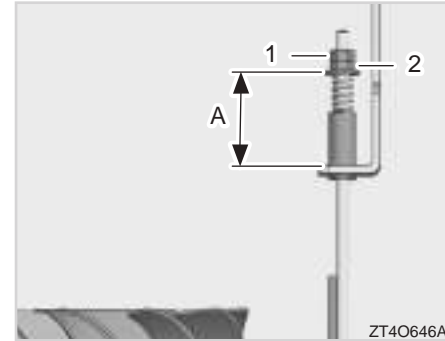

- (1) Lock Nut (2) Adjusting Nut
(A) 56mm ±5 (Length Adjustment)

1. Loosen the lock nut on the parking brake.
2. Check the operating force (20~27kg) of the parking brake, if it is insufficient, adjust it with the adjusting nut.

⚠ WARNING

- **Do not operate the mower if the parking brake is not operable. Damage to the mower or operator could occur.**

**⊕ IMPORTANT**

- **Improper adjustment of the parking brake can damage the mower.**

3. Tighten the lock nut on the parking brake.
4. If the mower is adjusted correctly, it should not roll down slopes (20°).

📖 NOTE

- If the procedures above do not allow you to adjust the brake to hold properly, contact your Authorized **KIOTI** Dealer for service.

CHECKING AND CHARGING THE BATTERY

(1) Battery

Periodically check the battery condition and charge level in accordance with the manufactures recommendation.

Mishandling the battery shortens the service life and adds to maintenance costs. If the battery is insufficiently charged, the engine is hard to start. It is important to inspect the battery periodically.

1. The battery cables should always be clean and firmly connected. When

installing a new or used battery, clean the battery terminals before installation.

2. Check the battery and cables for damage and corrosion.
3. Apply grease to the terminals and cable ends in order to prevent corrosion.

⚠ WARNING

Batteries produce explosive gas:

- **Always charge the battery in a well ventilated area to allow the gases produced during charging to dissipate.**

CHARGING

1. To slow charge the battery, connect the battery positive terminal to the charger positive terminal and the negative to the negative, and then recharge in the standard fashion.
2. Boost charging is only for emergencies. It will partially charge the battery at a high rate and in a short time. Repetitive boost charging will shorten the battery's service life or possibly damage the mower's charging system.
3. When the battery is discharged and should be replaced, replace it with a new one with the same specification and capacity.

BATTERY TYPE	VOLTS (V)
300 CCA/ SP-35 or equivalent	12

CAUTION

- **Keep the battery fully charged. If the battery's electrolyte fluid concentration is too low during the winter season, the battery may be frozen.**
- **Do not start the engine with a frozen battery.**
- **Never check the charge status of the battery by placing a metal object across the posts. Use a voltmeter or hydrometer.**

DIRECTIONS FOR STORAGE

1. When storing the mower for a long period, remove the battery from the unit and store in a dry place out of direct sunlight.
2. The battery self discharges while it is stored. Recharge it once every three months in hot seasons and once every six months in cold seasons.



CLEANING THE ENGINE SHROUD



(1) Engine Shroud (2) Mounting Bolt

1. Remove the engine shroud mounting bolts and remove shroud.
2. Check if the engine's cooling fan is covered with dust and clean with compressed air.

CAUTION

- Allow the engine to cool before removing the shroud.
- When cleaning, protect your eyes and face from foreign matter and objects.

EVERY 200 HOURS REPLACING ENGINE OIL FILTER

Refer to Pages 6-11 ~ 12

REPLACING TRANSAXLE OIL AND FILTER

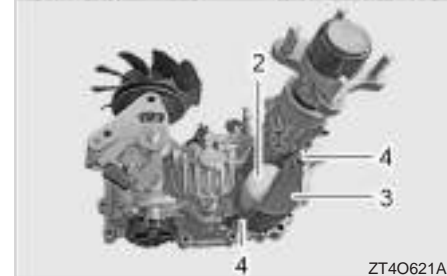
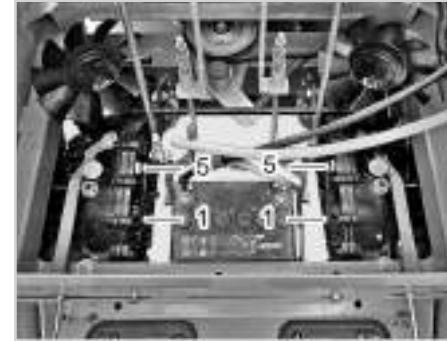

(1) Transaxle (2) Transaxle Oil Filter
(3) Filter Guard (4) Hex. Flange Bolt
(5) Air Bleeding Port Plug

1. Remove the hex flange bolts and filter guard and remove debris around oil filter.
2. Place the oil pan under the oil filter and remove the oil filter.
3. If oil spills, check all parts for excessive wear or damage and replace if necessary.
4. Check all visible parts for wear or damage and replace if necessary.
5. Wipe off the filter assembly surface and apply shallow oil on the new filter O-ring.
6. Thread the new filter on by hand and tighten 3/4 turn after the o-ring makes contact with the filter base.
7. Replace the filter guard with three hex flange bolts. At this time, torque the bolts to 7.35 N-m (5.42 lbf-ft).
8. Repeat steps 2 to 7 for the opposite transaxle.
9. Dispose of the used filter and the used oil in an appropriate container and dispose of in an approved disposal facility.
10. Disconnect the air breather port from the left and right side transaxles before refilling. This will ensure that the transaxles are vented while filling with oil.
11. Fill the oil until oil appears at the bottom of the breather port and attach the breather port plug to the transaxle.
12. Reinstall the breather plugs in each transaxle & then add 3 oz. of additional fluid to each transaxle.
13. Reinstall the fill cap in each transaxle.

► AIR BLEEDING PROCEDURE

Due to the effect of the air in all hydrostatic systems, bleeding air from the unit is very important. Air is inefficient because it is faster in compression and expansion than approved oils for use in all hydrostatic systems.

This air bleeding procedure must be carried out every time the entire hydrostatic system is serviced.

The following symptoms may occur if air exists in the hydrostatic system:

1. Noisy operation.
2. Lack of output and driving force after short-term operation.
3. High operating temperature and excessive expansion of oil.

Confirm that the fluid level is at the full mark in each transaxle before starting the bleeding process. The following procedure works best when the machine's wheels are off the ground.



EVERY 400 HOURS REPLACING THE FUEL FILTER

The air bleeding process should be performed in an open space with no people or other equipment in the surrounding area.

1. Lift the mower until the rear wheels clear the ground and support the mower on jack stands or approved blocks. Inspect closely and make sure that the supporting devices will not make contact with the rear wheels if rotated.
2. Start the engine & keep the engine speed at idle. Make sure the PTO is in the off position. Release the parking brake.
3. Slowly move the steering levers forward and backward (5 or 6 times) when the bypass valve is open and the engine is running.
4. Close the bypass valves and with the engine running, slowly move the steering levers forward and backward (5 to 6 times). After stopping the engine and applying the parking brake, check the oil level and replenish the oil.
5. Repeat steps 2 and 3 until all air is completely removed from the unit. When the transaxle operates at normal noise levels and smoothly moves back and forth at normal speed, the transmission is considered to have been purged of air.

Replace the fuel filter every 400 hours or sooner if the filter becomes clogged or debris is visibly present in the filter housing. Only use a filter approved by the engine manufacturer.

Always contact your Authorized **KIOTI** Dealer for assistance with maintenance or service that is beyond your technical capabilities.

EVERY 500 HOURS ADJUSTING THE PTO CLUTCH



(1) PTO Clutch

The electromagnetic PTO clutch has two functions for mower operation. In addition to starting and stopping power flow to the cutter blades, the clutch acts as a brake to help stop the blade rotation if the PTO is off or the operator's presence control is triggered.

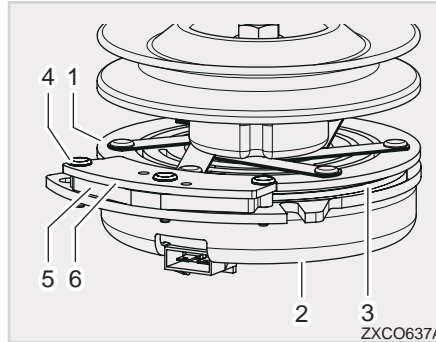

(1) Armature (4) Brake Mounting Bolt
(2) Field Shell (5) Brake Spacer
(3) Rotor (6) Brake Pole

No adjustment required. However, clutch brakes can wear out to the point where the clutch is no longer engaged. Removing shims will extend the clutch life.

REMOVING SHIM

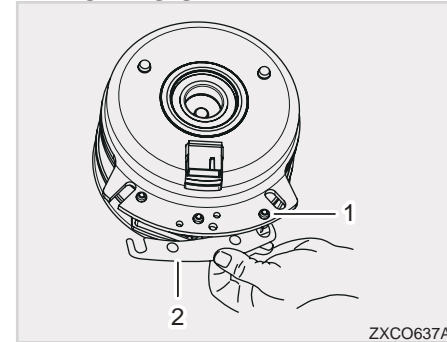

(1) Brake Mounting Bolt (2) Shim

1. Place the mower on a flat, level surface, turn the PTO off and engage the parking brake. Turn the engine off and remove the key from the ignition. Allow the engine and mower to cool off before performing any work.
2. Using compressed air, clean the clutch and the area around the clutch. Always wear proper eye and ear protection before using compressed air.



3. Check the condition of the clutch wiring, connectors and terminals. If necessary, clean or repair.
4. Measure the gap between the rotor and armature and proceed to the next step if the gap is greater than 0.04 in.

ADJUSTING THE BRAKE

- Loosen the two brake mounting bolts from one half to a full turn.

IMPORTANT

- **Do not remove the brake pole from the field shell / armature. The brake pole must be fitted to match the armature and must be consistent after the shim has been removed to ensure proper brake torque.**

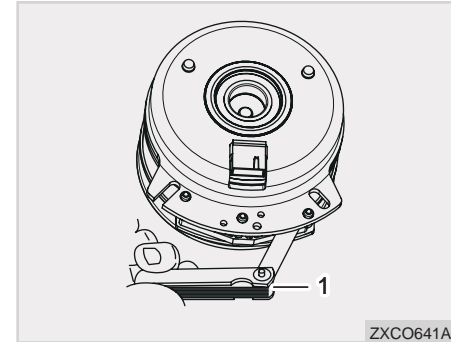

(1) Feeler Gauge

- Use pliers to remove the shims by holding the clutch shell in one hand and sliding the shims from underneath the brake pole with the pliers
- Use compressed air lines to blow debris away under the brake pole and around the brake spacers. As needed. Always wear proper eye and ear protection when using compressed air.

- Re-tighten each bolt to 13 N-m (1.3 kgfm or 9.6 ft-lb) \pm 0.7 N-m (0.07 kgfm or 0.52 ft-lb).
- Use a 0.010 inch feeler gauge to check for gap widths between the rotor and amateur surfaces on either side of the brake pole as shown. (In some cases it is difficult to measure true gaps due to the way rotors and armatures face each other (peaks and valleys).)
 - If the gap is less than 0.010 in, refer to the section on troubleshooting and reinstall the shim and proceed with the check.
 - If there is enough gap, proceed to the safety check as follows.

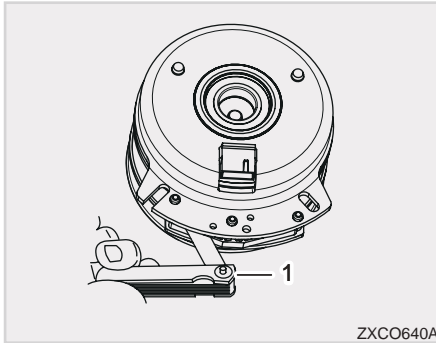

(1) Feeler Gauge

- Start the engine.
- Make sure the blades Do Not engage with the PTO switch "off" and the clutch disengaged. If the clutch is not connected properly, refer to the troubleshooting section
- Check that the PTO switch is "OFF" and the clutch is disengaged from the blade. If the clutch doesn't disengage, refer to the troubleshooting section and reinstall the shim.

EVERY 1 YEAR REPLACING AIR CLEANER ELEMENT

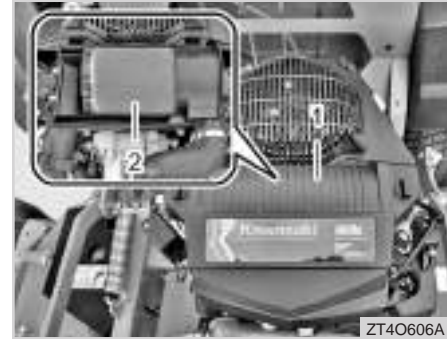
(1) Air Cleaner Cover (2) Locking Cap
(3) Air Cleaner Element

Failure to inspect and clean or replace the air filter periodically could lead to reduced performance and shortened life expectancy of the engine. The filter should be inspected at a minimum after 50 hours of service. When operated in dry, dusty conditions for extended periods of time, the filter should be inspected weekly or daily for commercial users.

1. Inspect the intake hose and air cleaner housing for damage.



(1) Suction Hose (2) Air Cleaner Element

2. Rotate the 2-locking caps 1/2 turn counter-clockwise and remove the cover.
3. Clean the inside of the air cleaner housing thoroughly.
4. Replace the air cleaner element and inspect the housing for damage.
5. Rotate the 2-locking caps 1/2 turn clockwise to secure.

⚠ CAUTION

- Only use genuine Kawasaki or KIOTI components to ensure the exact fit and performance to prevent damage and maintain your mowers for year's of service.
- Tighten the air filter cover firmly to prevent dust from entering.
- Do not allow dust or foreign matter to enter the air intake port when removing the element.

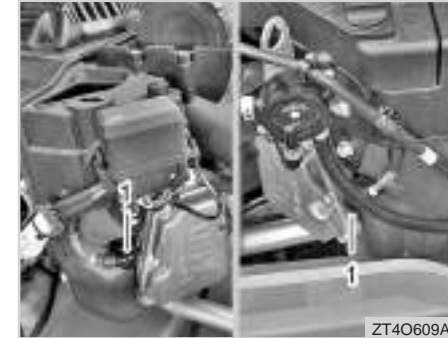

(1) Spark Plug (Both Sides)

Check the spark plugs condition and filament gap every 100 hours or replace every year, depending on use. Refer to page 6-12 for removal & re-installation.

SERVICE AS REQUIRED REPLACING FUSES

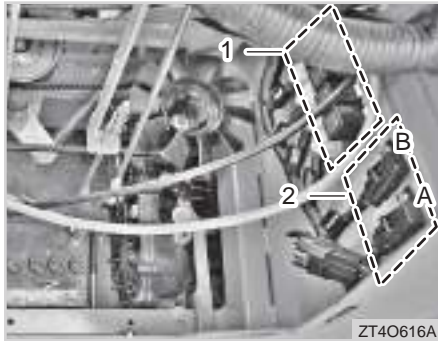

(1) Relay

(2) Fuse Box

1. At the rear of the mower, lift the cushion pad upward and pull back gently to remove it from the mower frame.
2. Inspect the fuses for damage and replace damaged or blown fuses with a new fuse of the same type and capacity.
3. To reinstall the operator pad/cushion, align the tabs on the back of the pad into the slots in the mower

frame. Push downward on the pad until the tabs bottom out in the slot.

⊕ IMPORTANT

- **Never use wire or silver foil as a fuse replacement.**

4. The main fuse protects the following functions.

NO	PROTECTION CIRCUIT	CAPACITY
A	Regulate	25A
B	Control panel	20A
C	Power outlet	10A

CHECKING BLADES

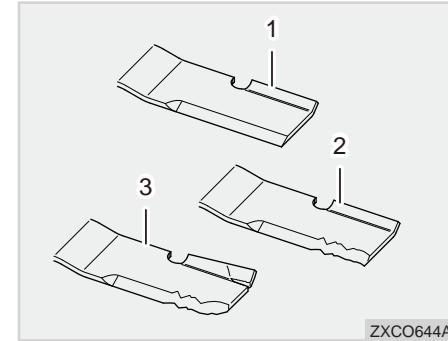

(1) New Blade

(2) Worn Blade

(3) Cracked Blade

NEVER place any part of your body, tools or other items near a mower deck before you've confirmed the mower is on a flat surface, the parking brake is engaged, the PTO is off, the blades are not rotating, the engine is off and the key has been removed from the ignition switch.

1. The blades can be inspected by raising the discharge chute and looking underneath the deck or lifting and securing the front of the mower.



2. For best performance, the blades should be maintained and kept sharp. Blades with dull, blunt or cutting edges with knicks and gouges should be sharpened or replaced as needed. Bent, cracked or damaged blades should be replaced immediately and could lead to serious issues if left unattended.
3. Always torque the blades to the correct specification when removing or replacing.
4. Inspect the blades daily to make sure the blades are tight and sharp with no signs of damage.

BLADE TIGHTENING TORQUE

103 ~ 118 N · m
(76 ~ 87 ft · lb)
(10.5 ~ 12.0 kgf · m)

⚠ WARNING

- ***Improperly equipped blades or related components used to secure the blade are extremely dangerous. If you do not use the original parts or if they are installed incorrectly, the blades or other parts may protrude causing serious injury or death.***
- ***Always wear the proper hand and eye protection when working with cutter blades.***

INSPECTION AND SHARPENING BLADES

1. Make sure that the engine is off, the parking brake is set, and the blades have stopped moving completely.
2. Raise the mower deck to its highest, locked position.
3. Use care when checking the cutting blades. Do not touch the blades directly, wear safety gloves or use a blade buddy to hold the blades during removal.
4. Bent, broken or severely worn blade. NEVER attempt to straighten or weld a blade.
5. When sharpening blades, do not remove more than 1/4" of material from the overall blade width. A further reduction in the width of the blade could lead to reduced performance and durability. Always sharpen the blade cutting edge at the same angle as the original.

⚠ WARNING

- *Always confirmed the mower is on a flat surface, the parking brake is engaged, the PTO is off, the blades are not rotating, the engine is off and the key has been removed from the ignition switch before performing any work on the mower.*

REPLACING BLADES

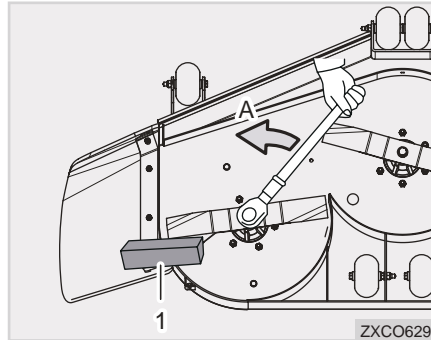

(1) Block
(A) Loosen

1. Remove grass & dirt from the top & underneath the mower deck before removing the blades. When re-installing, be sure to remove any dirt/debris from underneath the spindle covers. All covers should be installed and in place before operating the mower.
2. Lift the front of the mower to make the blades visible and accessible. Be sure to use jack stands and make sure the parking brake is set

and the mower is secure before performing any work on the mower.

3. Place a block of wood between the blade and the mower housing to prevent the spindle from rotating when loosening the mower blade.
4. When sharpening the blade, firmly in a vise. Use a large file or a small grinder with buffing wheel to remove nicks from the blade or restore the original angle to the cutting edge.
5. To check the balance of the blade, pass a small rod through the center hole. If the blade is unbalanced, file the heavy side of the blade until the blade is balanced.
6. When mounting the blade, be sure to insert the spring between the blade and the bolt. And allow the blade to balance. The blade should rest level side to side. If not, sharpen the heavier side (the side that angles downward) more. Perform the balance test again to confirm the blade is balanced before



re-installing on the mower deck.

- Remove grass and dirt from above and inside the mower before inspecting or replacing the blade. In particular, clean the inside of the belt cover. If not cleaned, the life of the belt will be shortened.

⊕ IMPORTANT

- When removing the blade mounting bolts, use an appropriate socket or wrench.

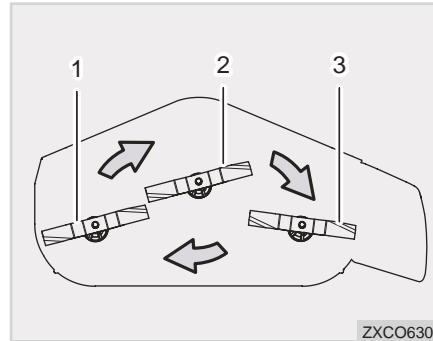

(1) Blade (LH) (2) Blade (Center)
(3) Blade (RH)

- Tighten the blade mounting bolts to a torque of 103 to 118 N·m (76 to 87 ft·lb or 10.5 to 12.0 kgf · m).

REPLACING MOWER BELT

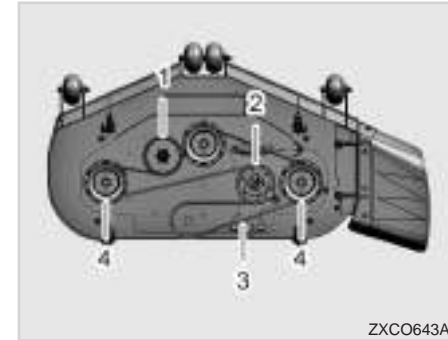

(1) Idler Pulley (2) Belt Tensioner
(3) Belt (4) Spindle

- Remove center, left and right belt guards.
- Set the cutterdeck in a middle height-of-cut position.
- Loosen bolt on belt guide so belt guide can be moved to remove the belt.
- Insert 3/8" ratchet extension in hole A on the idler arm to back tensioning idler off to remove belt from idler. Remove belt from cutterdeck pulleys.
- Remove belt from clutch pulley.

6. Install the new belt by performing these steps in reverse order.
7. Cutterdeck spring will require tension adjustment after belt installation. Adjust eyebolt so the distance between the inside of the spring hooks is $6\text{-}3/4 \pm 1/8$ ".
8. Reinstall cutterdeck belt and guards.

ADJUSTING BELT TENSION

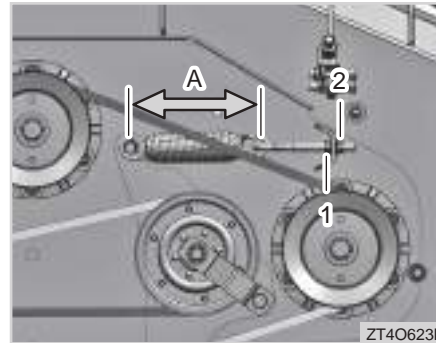

(1) Nut 1 (2) Nut 2
(A) Adjusting Length of Belt Tension

1. Loosen the nut 1.
2. Tighten or loosen nut 2 and set the length of "A" as follows.

DECK SIZE	ADJUSTING LENGTH
48"	7.7"±0.2" (195mm±5mm)
54"	8.5"±0.2" (215mm±5mm)

3. Tighten nut 1.

CONTROLS DAMPER ADJUSTMENT

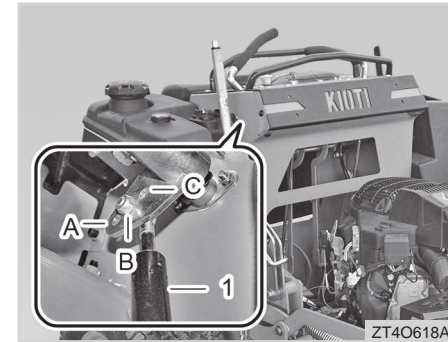

(1) Damper
(A) Inner Position (B) Center Position
(C) Outer Position

Steering control dampers are installed on the L & R steering levers to assist with the steering control of your mower. There are three adjusting points on each damper.

- Center point: Standard
- Outside point: It makes harder damping for tight traction control.
- Inside point: Softer damper for light traction control.

**⚠ CAUTION**

- **Stop the mower, disengage the PTO, set the parking brake and turn the engine off before making any adjustments. Wait for all moving parts to come to a complete stop before beginning work.**
- **The engine and drive unit can get hot during operation causing burn injuries. Allow the engine and drive components to cool before making any adjustments.**

📖 NOTE

- Before adjusting the dampers, check the front casters and make sure the spindles will rotate freely. Drive tire pressure should also be checked and adjusted to maximum inflation. Operating the mower with uneven tire pressure or properly rotating spindles could cause the mower to pull slightly to one side during operation and could be more noticeable depending on the damper position.

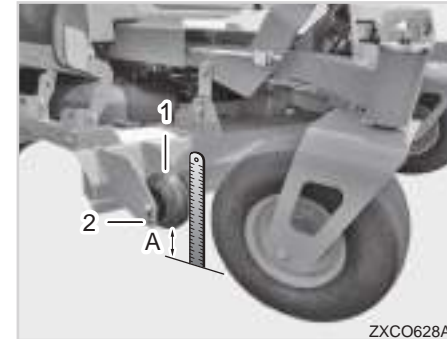
ADJUSTING ANTI-SCALP ROLLERS

(1) Anti-Scalp Roller (2) Height Adjust Hole
(A) Ground Height: 0.75 in.

1. Inspect the machine tire air pressure and inflate to the correct pressure.
2. With the engine in the off position and the parking brake engaged, lift the mower deck to the “lock” or transport position.
3. Adjust the mower deck to your preferred cutting height (most often used) with the cutting height adjustment pin and lower the mower deck.

4. Adjust the right front anti-scalp wheel to approximately 0.75 inches . If you normally cut at a height above 3 inches, it is recommended to adjust the anti-scalp wheels to the lowest setting.

⊕ IMPORTANT

- **Check the Anti-scalp wheels adjustments whenever the mower deck cutting height changes.**
- **The deck is designed to free float and not run on the anti-scalp wheels all the time. Running the deck on the anti-scalp wheels will diminish cutting performance and also cause accelerated wear to the anti-scalp wheels.**

ADJUSTING DECK LEVEL (SIDE TO SIDE)

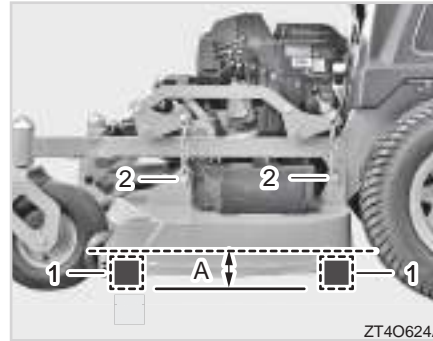

(1) Block (2) Deck Height Adjust Bolt
(A) Blade Height

1. Park the machine on a solid, level surface like concrete. Make sure the deck is in the “lock” or transport position. Confirm the air pressure in all 4 tires is set to the maximum recommended inflation.
2. Using 4 blocks of the same size, place a block under each corner of the deck. Soft wood blocks are not recommended as the deck may settle into the blocks. Treated wood, metal or other solid, durable

material are recommended. Be sure the deck edge is resting on the blocks and no part of the anti-scalp wheels are resting on the block.



(1) Cutting Height Pin

3. Place the cutting height pin in the cutting height position that equals the height of the blocks and gently lower the deck onto the blocks. Note: The blades are approximately 3/16" (4.76 mm) higher than the lower edge of the deck.
4. Check the following 2 items:
 - 1) Make sure the deck is resting on the blocks at all 4 corners.
 - 2) Raise the discharge chute and rotate the right blade so the

cutting edge is pointing forward. Measure the height of the blade. The height should be within 1/8" (3.175 mm) of the selected cutting height.

5. At each corner of the deck, loosen the deck height adjusting bolt. Move the bolt in the slot on the deck to tighten the chain. Re-tighten the deck height adjusting bolt to 92~110 ft lbs.
6. Once complete, raise/lower the deck multiple times. Re-check the blade height and adjusting bolts to confirm the deck position has not changed.

ADJUSTING DECK RAKE (FRONT TO REAR)

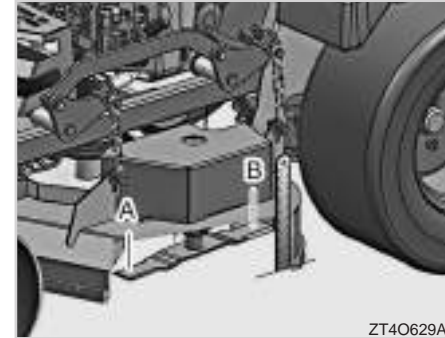

(A) Front

(B) Rear

1. Follow the steps outlined for the deck level process. To adjust the rake, the rear blocks will need to be 1/8" - 1/4" (3.175 mm - 6.35 mm) taller than the front blocks.
2. To confirm the rake is correct, rotate the blade so the cutting edge faces forward. The front cutting edge should measure within 1/8" of the cutting height position selected. The rear cutting edge should measure 1/8" - 1/4" (3.175 mm - 6.35 mm)

HYDROSTAT TRANSAXLE ADJUSTMENT



ZT40620A

(1) Lock Nut

higher than the front edge. The difference between the front cutting edge and rear cutting edge is the rake of the deck. The difference measured in the heights of the front/rear cutting edges should match the difference between the front blocks and rear blocks used when performing this process.



ZT40647A

(1) Control Lock Rod



ZT40622A

(1) Adjust Nut
(3) Nut(2) Control Rod
(4) Control Lock Rod

The neutral position for each transaxle is set through the adjustment of the control rod connected directly to the steering lever. The parking brake, when engaged, also locks each steering lever to prevent accidental movement or engagement of the transaxles which could lead to damage while the parking brake is applied.

To adjust the neutral position and park lock, follow these steps:

1. Make sure the mower is parked on a flat, level surface with the engine off.
2. Release the parking brake and confirm that the steering levers will operate freely.
3. Loosen the adjusting nut on each end of the LH and RH steering control rod.
4. Adjust the RH steering lever so it rests in the center of the machined recess for "neutral" in the forward and reverse slot of the control panel. Once complete, tighten the adjuster



nuts.

5. Adjust the LH steering lever so the tip of the steering lever aligns with the tip of the RH steering lever (when the lever is pushed downward out of the neutral recess). Once complete, tighten the adjuster nuts.
6. With both steering levers released and resting in the “neutral” position, engage the parking brake. If the parking brake will engage & lock the steering levers in neutral, no additional adjustments are required . If the parking brake will not engage, the parking brake control lock rods must be adjusted.
7. Loosen the nut on the LH and RH control lock rods.
8. While moving the parking brake lever to “engage”, position the LH & RH control lock rods in the corresponding slots.
9. Once each rod is aligned with their corresponding slot, finish engaging the parking brake and tighten the

LH and RH lock rod adjustment nut.

10. Operational test. Start the engine and release the parking brake while holding the RH steering lever down to engage the operator presence. Make sure the unit does not move or creep. Operate the unit for 5 minutes at high RPM's and then bring the unit to a stop. While holding both levers in neutral, make sure the unit does not move or creep.
11. Engage the parking brake. Make sure the engine is not laboring or there are any signs that one or both transaxles are still engaged. With the parking brake engaged, turn the engine off and wait 15 seconds.
12. Re-start the engine and release the parking brake while holding the RH steering lever down to engage the operator presence. Make sure the unit does not move or creep. Should the unit begin to move or creep, repeat the adjustment procedure.



MEMO





STORAGE AND DISPOSAL

MOWER STORAGE	7-2
DAILY STORAGE	7-2
LONG-TERM STORAGE	7-2
USING MOWER AFTER LONG TERM STORAGE	7-3
USAGE AND DISPOSAL.....	7-4

7

7

MOWER STORAGE

DAILY STORAGE

1. Remove dust, debris and grass residue daily from the mower deck, underneath the spindle covers, and around the engine and transaxle areas daily. Always check for loose or missing hardware or other maintenance issues while cleaning or inspecting the mower.
2. Always store the mower indoors or underneath a shelter or covered area if possible.

DANGER

- ***Use caution when operating the mower in an enclosed area. Be sure to ventilate the area well and allow exhaust gases to escape. Exhaust gases contain Carbon Monoxide which is a colorless and odorless gas that can cause severe issues, including death with prolonged exposure.***

LONG-TERM STORAGE

IMPORTANT

- **If the mower is not used for an extended period of time, follow the instructions below to prevent corrosion and performance deterioration of the mower while it is stored.**

1. Always check for loose or missing hardware. Tighten or replace as needed.
2. Grease and lubricate all pivot points. Apply a light film of grease to any bare metal surfaces that may rust or corrode during long-term storage.
3. Remove any weights, grass collection or other items added to the mower.
4. Inflate the tires to the maximum recommended operating pressure.
5. Change the engine oil and filter. Operate the engine for 5-10 minutes to circulate the fresh oil throughout the system.
6. Drain the fuel system or add a fuel stabilizer. Should you choose to add a fuel stabilizer, be sure to follow the manufacturer's recommended guidelines for application. Fill the fuel tank with fresh fuel and treat the entire contents with fuel stabilizer. Operate the mower for 10 minutes to ensure treated fuel is circulated throughout the entire fuel system.
7. With mower deck lowered to the ground, coat any exposed area with grease.
8. Remove the battery from the mower. Store the battery following the battery storage procedures. (See section "Battery" in Chapter Maintenance)
9. Store the mower indoors or underneath a shelter or covered area if possible.
10. Clean the mower and remove dust, debris and grass residue. Always store the mower "clean" and free of any materials that rodents or other animals may utilize for nesting.

USING MOWER AFTER LONG TERM STORAGE

11. Store the unit with the tires resting on concrete or blocks to prevent premature deterioration of the tires.
12. Cover the exhaust to prevent material build-up during storage or animals nesting.
13. Attach a tag onto the mower to inform the storage condition of the mower.

CAUTION

- **Never clean the mower while the engine is running.**
- **Remove the key from the ignition during storage.**
- **Cover the mower after the muffler and the engine have cooled down.**
- **If you are not removing the battery during storage, disconnect the both terminals of the battery from the mower's electrical system.**

1. Check the tire air pressure and inflate the tires to the recommended operating pressure if they are low.
2. Reinstall the battery or re-connect the cables. It is recommended to charge the battery prior to installation or re-connection to ensure the battery is at full charge.
3. Check all fluid levels.
4. Remove any grease applied to bare metal surfaces or exposed areas covered to prevent rust.
5. Apply grease to the lubrication points.
6. Get onto the mower and start the engine and allow it to run for a few minutes before moving the mower.
7. check the operation of all components by turning left/right and moving forward/backwards, engage the parking brake. Raise/lower and raise the deck. Engage the PTO. Stop the mower, dis-engage the PTO, apply the parking brake and turn the engine off and inspect for leaks, damaged

or frayed belts, loose or missing hardware.

8. Repair any items damaged during storage before putting the mower into use.



USAGE AND DISPOSAL

In order to protect the environment, use and dispose of all waste fluids, damaged or replaced parts on the mower with the following in mind:

1. Catch oil or coolant in containers designed to handle those products. Never mix oil and coolant in the same container. Always dispose of used fluids according to local state, province or municipality regulations.

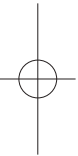



TROUBLESHOOTING

ENGINE TROUBLESHOOTING 8-2

BATTERY TROUBLESHOOTING..... 8-5

MOWER TROUBLESHOOTING 8-6

8

8



ENGINE TROUBLESHOOTING

CAUSE		COUNTERMEASURES
1. Engine does not turn over	• Steering levers are not in neutral	• Set steering levers to "Neutral"
	• The parking brake is not engaged	• Engage the parking brake
	• The PTO is in the "ON" position	• Set the PTO switch to the "OFF" position.
	• Battery is discharged	• Charge or replace the battery
	• Fuse failure	• Check the fuses
	• Relay or switch defective	• See your KIOTI dealer
	• Electrical connections are corroded or loose	• Clean and check electrical connections
2. Engine turns over but will not start	• Out of fuel	• Refuel
	• Clogged or damaged fuel hose or fuel filter	• Clean or replace fuel line or see your KIOTI dealer
	• Poor fuel quality	• Change fuel and fuel filters
	• Water and dust in the fuel system	• Fuel change or see your KIOTI dealer
	• Spark plug is defective	• Adjust spark plug gap, or replace
	• Dirty or clogged air cleaner filter	• Clean or replace air cleaner filter



CAUSE		COUNTERMEASURES
2. Engine turns over but will not start	• Fuse short	• Replace fuse
	• Relay or switch defective	• See your KIOTI dealer
	• Battery is weak	• Charge or replace the battery
3. Insufficient engine power	• Engine overload	• Reduce workload
	• Fuel filter clogged	• Replace fuel filter
	• Air cleaner filter contamination	• Clean or replace air cleaner filter
	• Spark plug is defective	• Adjust or replace spark plug
4. Engine is running rough, not smooth	• Spark plug is defective	• Adjust spark plug gap, or replace
	• Defective carburetor or ignition coil	• See your KIOTI dealer
	• Clogged air cleaner	• Clean or replace air cleaner
	• Choke is incorrectly adjusted	• See your KIOTI dealer
	• Poor fuel quality	• Change fuel and fuel filters
5. When the exhaust color is white or blue	• Excessive engine oil	• Reduce engine oil level to specified value
	• Piston ring worn or stuck	• See your KIOTI dealer
	• Improper weight or grade of engine oil	• Change engine oil/filter and refill with correct weight and grade per engine manufacturer's recommendations



CAUSE		COUNTERMEASURES
6. When the exhaust color is black or gray	• Engine overload	• Reduce workload
	• Old or stale fuel	• Drain fuel and refill with new fuel 87 octane or higher
	• Clogged fuel filter	• Replace fuel filter
	• Clogged air filter	• Clean or replace air cleaner filter
	• Choke is not open enough	• Check choke position
7. When the engine overheats	• Engine overload	• Reduce workload
	• Engine oil shortage low	• Check oil level and replenish if necessary
	• Contamination of engine air intake and cooling fins	• Clean engine air intake and cooling fins
	• Clogged air cleaner filter element	• Clean or replace air cleaner element
	• Engine speed is too low	• Operate engine at "high speed"
	• Driving too fast/excessive workload	• Drive slower/reduce workload
8. When the engine does not idle	• Spark plug is defective	• Adjust spark plug gap, or replace
	• Carburetor problems	• See your KIOTI dealer

※ If you have any questions or require assistance diagnosing or repairing your mower, please contact your authorized **KIOTI** Dealer.

**BATTERY TROUBLESHOOTING**

	CAUSE	COUNTERMEASURES
1. The engine will not turnover	• The battery is discharged	• Recharge or replace the battery
	• Damaged or corroded battery connections	• Clean and reconnect battery terminals
	• Dead battery	• Replace battery
	• Defective wiring and switch	• See your KIOTI dealer
2. The battery will not charge	• Defective battery	• Replace battery
	• Defective coil	• See your KIOTI dealer
3. Terminal or battery connections become hot	• Weak or defective connection	• Clean and re-tighten terminals

※ If you have any questions or require assistance diagnosing or repairing your mower, please contact your authorized **KIOTI** Dealer.



MOWER TROUBLESHOOTING

	CAUSE	COUNTERMEASURES
1. The engine is running but the mower will not move	• Insufficient transaxle oil	• Inspect and refill the transaxle to the correct level
	• Transaxles are not engaged	• Inspect drive linkages and transaxle release mechanism (for towing)
2. Mower does not drive smoothly	• Insufficient transaxle oil	• Transaxle oil replenishment
	• Clogged transaxle filter	• Replace transaxle filter
	• Linkage is out of adjustment	• See your KIOTI dealer
3. The mower moves when the parking brake is released or does not sit still when steering levers are in neutral	• HST shift to transaxle linkage is out of adjustment	• See your KIOTI dealer
	• Steering lever linkage pivot is sticking	• Lubricate the linkage
4. When the blades do not rotate	• PTO switch is defective	• See your KIOTI dealer
	• Mower belt is broken	• Replace mower belt
	• Mower belt tension is insufficient	• Check the belt routing and adjust the tension
	• Mower belt is not connected	• Reinstall mower belt on the pulley
5. The discharge outlet becomes clogged	• Grass is too wet	• Allow the grass to dry before continuing to operate
	• Cutting too low or removing too much material for a single pass	• Increase cutting height and cut grass twice





CAUSE		COUNTERMEASURES
5. The discharge outlet becomes clogged	• Engine speed too low	• Increase engine speed
	• Travel speed is too fast	• Reduce travel speed
6. The mower belt is slipping	• Weak or improperly adjusted	• Check tensioner adjustment and/or replace spring
	• Worn or damaged belt	• Replace mower belt
7. Overall cut finish is poor or leaving uncut grass	• Travel speed is too fast	• Reduce travel speed
	• Engine speed is too low	• Increase engine speed to maximum
	• Cutting too low or removing too much material for a single pass	• Increase cutting height and cut grass twice
	• Worn or damaged blade	• Sharpen or replace blades
	• Grass and debris deposits underneath deck	• Clean the underside of the mower deck
8. Cut is not even or uniform from side to side	• Mower deck is not level	• Check and adjust deck level if needed
	• Travel speed is too fast	• Reduce travel speed
	• Worn or damaged blade	• Sharpen or replace blades
	• Low tire pressure	• Inflate tire to specified air pressure



	CAUSE	COUNTERMEASURES
9. Excessive vibration	• Grass and debris deposits underneath deck	• Clean the underside of the mower deck
	• Broken belt	• Replace with new belt
	• Twisted belt	• Remove twist from belt or install a new belt if damaged
	• Broken pulley	• Replace with new pulley
	• Damaged or broken blade	• Replace with a new blade
10. Mower scalps or cuts into soil	• Blade height is too low	• Raise blade height
	• Un-even terrain	• Inflate tires to maximum recommended pressure. Check and adjust anti-scalp wheels based on desired cutting height
	• Bent blade	• Replace with new blade
11. When the mower's load is high	• Engine speed is too low	• Increase engine speed to maximum
	• Travel speed is too fast	• Reduce travel speed
	• Grass and debris is wrapped around the blades	• Inspect and clean the underside of the mower deck as needed

※ If you have any questions or require assistance diagnosing or repairing your mower, please contact your authorized **KIOTI** Dealer.





INDEX

INDEX..... 9-2

9

9



A

ABOUT SERVICE2-1
 ADJUSTING ANTI-SCALP ROLLERS6-31
 ADJUSTING BELT TENSION6-30
 ADJUSTING DECK LEVEL (SIDE TO SIDE)6-32
 ADJUSTING DECK RAKE (FRONT TO REAR)6-33
 ADJUSTING THE BRAKE6-23
 ADJUSTING THE CUTTING HEIGHT5-19
 ADJUSTING THE PTO CLUTCH6-22
 ADJUSTING TRANSAXLE DRIVE BELT TENSION6-14
 AIR FILTER MAINTENANCE6-11

B

BATTERY & FUSE LOCATIONS5-21
 BATTERY TROUBLESHOOTING8-5

C

CHANGING THE ENGINE OIL AND FILTER6-12
 CHARGING6-18
 CHECKING AND ADDING FUEL6-7
 CHECKING AND CHARGING THE BATTERY6-17
 CHECKING AND CLEANING THE AIR INTAKE SCREEN...6-9
 CHECKING BLADES6-26
 CHECKING ENGINE OIL LEVEL6-6
 CHECKING THE FUEL LINES/FUEL FILTER6-13
 CHECKING THE PARKING BRAKE6-16

CHECKING THE SPARK PLUGS6-13
 CHECKING THE SPARK PLUGS6-25
 CHECKING THE TRANSAXLE FLUID LEVEL6-9
 CHOKE LEVER4-5
 CLEANING THE ENGINE SHROUD6-19
 CLEANING THE MOWER DECK5-23
 CONTROLS DAMPER ADJUSTMENT6-30
 CUP HOLDER4-7
 CUTTING HEIGHT PIN4-6

D

DAILY CHECKS6-6
 DAILY STORAGE7-2
 DECAL MAINTENANCE1-15
 DECAL MOUNTING LOCATION1-13
 DECALS1-14
 DECK5-2
 DECK LIFT HANDLE4-5
 DESCRIPTION OF OPERATING SYSTEM4-3
 DIRECTIONS FOR STORAGE6-18

E

ENGINE SERIAL NUMBER2-2
 ENGINE TROUBLESHOOTING8-2
 EVERY 1 YEAR6-24
 EVERY 100 HOURS6-12



EVERY 200 HOURS6-19
 EVERY 400 HOURS6-21
 EVERY 50 HOURS6-11
 EVERY 500 HOURS6-22
 EXTERIOR VIEW4-2

F
 FUEL GAUGE4-3

G
 GENERAL INFORMATION6-6
 GENUINE PARTS2-4

H
 HOUR METER4-4
 HOW TO LIFT THE MOWER5-22
 HYDROSTAT TRANSAXLE ADJUSTMENT6-34

I
 INDEX9-1
 INSPECTION AND SHARPENING BLADES6-27

J
 JUMP STARTING5-7

K
 KEY SWITCH4-3

L
 LONG-TERM STORAGE7-2
 LUBRICANTS6-5
 LUBRICATION6-10

M
 MAINTENANCE1-9
 MAINTENANCE6-1
 METRIC FASTENER TORQUE CHART3-5
 MOUNTING AXLE BELT6-15
 MOVING MOWER WHEN THE ENGINE IS STOPPED 5-16
 MOWER CONTROLS LAYOUT4-1
 MOWER DECK INSTALLATION5-2
 MOWER DECK REMOVAL5-4
 MOWER OPERATION5-9
 MOWER SERIAL NUMBER2-2
 MOWER STORAGE7-2
 MOWER TROUBLESHOOTING8-6

O
 OPERATING1-4
 OPERATING THE ENGINE5-5
 OPERATING THE MOWER5-20



O

OPERATION5-1
 OPERATION5-9
 OWNERS RESPONSIBILITY1-3

P

PARKING1-9
 PARKING5-17
 PARKING BRAKE LEVER4-6
 PRECAUTIONS BEFORE OPERATION.....1-2
 PTO SWITCH4-5

R

RECOMMENDED MAINTENANCE SCHEDULES6-3
 REFERENCE CONTROL FRONT LEVER4-6
 REMOVING SHIM6-22
 REPLACING AIR CLEANER ELEMENT.....6-24
 REPLACING BLADES.....6-28
 REPLACING ENGINE OIL FILTER6-19
 REPLACING FUSES6-26
 REPLACING MOWER BELT.....6-29
 REPLACING THE FUEL FILTER.....6-21
 REPLACING TRANSAXLE OIL AND FILTER6-19

S

SAE FASTENER TORQUE CHART3-4

SAFE OPERATING PRACTICES.....1-3
 SAFETY DECAL MAINTENANCE.....1-13
 SAFETY PRECAUTIONS1-1
 SERVICE2-3
 SERVICE AS REQUIRED6-26
 SERVICING ENGINE AND DRIVE TRAIN COMPO-
 NENTS2-4
 SPECIFICATIONS3-1
 SPECIFICATIONS3-2
 STARTING THE ENGINE.....5-5
 STEERING LEVERS4-4
 STOPPING5-16
 STOPPING THE ENGINE5-8
 STORAGE AND DISPOSAL7-1
 STORING1-11
 SUPPLYING SERVICE PARTS2-3

T

THROTTLE LEVER4-3
 TIPS FOR BREAKING-IN5-9
 TIRES4-7
 TORQUE TIGHTENING CHART3-4
 TOWING5-18
 TRANSAXLE NUMBER.....2-2
 TRANSPORTING5-18
 TRANSPORTING1-12



TROUBLESHOOTING8-1

U

USAGE AND DISPOSAL.....7-4

USING MOWER AFTER LONG TERM STORAGE.....7-3

V

VEHICLE IDENTIFICATION NUMBER.....2-2

W

WASHING MOWER.....5-23

WHEEL4-8



MEMO

