



Cabinless remotely operated
skid steer loader.

ELISE700*CBL*

ELISE900*CBL*

ELISE1200*CBL*

first.green

Advantages of cabinless, remotely operated machines.



Enhanced safety

Without an operator inside, there is no risk of injury or exposure to hazardous materials, making it safer for operators and allowing for work in dangerous environments.



Versatility

Remote-operated machines can access areas where it's not feasible for a human operator to be present, such as in contaminated zones, underground, or in extreme weather conditions.



Precise control

Remote control technology often enables more precise and fine-tuned movements, leading to increased accuracy in tasks like excavation or material handling.



Adaptability

Remote-operated machines can be adapted for various industries and tasks, from construction and agriculture to mining and disaster response.



Increased maneuverability

The absence of a cabin allows for a more compact design, enabling the machine to navigate tight spaces and work in confined areas with ease.



Cost savings

Eliminating the need for a cabin reduces the weight and overall cost of the machine, making it more cost-effective and fuel-efficient.



Battery hot swap

Our hotswap capability, ensures seamless and continuous operation. This allows for uninterrupted performance and eliminates potential downtime.



Improved visibility

Remote operation comes with advanced camera systems, providing operators with a comprehensive view of the surroundings, enhancing precision and safety.



No need for rollover and falling objects certification: Since there is no operator inside the machine, you eliminate the need for certification related to operator safety in the event of rollovers or falling objects.

Scalable lineup for every task



ELISE 700 CBL

Lithium

ELISE 900 CBL

Lead-acid

ELISE 1200 CBL

Lead-acid / Lithium

*models are named according to their loading capacity

Where man can't tread, we lead instead.

With remote operation and the ability to access challenging terrains where people cannot tread, our skid steer loader redefines productivity and safety, setting the industry standard for autonomy and precision.



**Fully electric,
noiseless,
zero emission.**



Powered with technology.

Cabinless Elise. No place is off-limits - we make the unreachable, operable.



Battery endurance

4-6+ hours

Dependant on use, conditions and configuration

Hinge pin height

3665 mm

384 mm higher reach than the competing average

Side tilt

35°

Greater terrain performance thanks to lower center of gravity

100% electric, extremely low noise, 0 emission

Expected in Q1 2024

Lithium battery available

Low operational costs

Retrofittable modular construction

Microspeed for precise control

Self-leveling gyro platform

Chassis clearance

262 mm

44 mm higher
than competing average

Remote control

50 m

15 m with
smart app

Loading capacity

700 - 1500 kg

Depending on
selected model

Technical specs.



GENERAL SPECIFICATIONS

Rated load capacity	700-1 500 kg
Tipping load	1 800-2 400 kg
Minimum travel speed	0.15 km/h
Maximum speed	12-15 km/h
Maximum travel speed	12-15 km/h

MOTOR

Electric engine type	3x Best Motor
Rated power	3x10 kW
Maximum power	3x27 kW
Maximum torque	3x160 Nm

TUNE-UP YOUR MACHINE

Options

- Rubber or steel track set for increased traction
- Cable set pre-install for electric attachments
- Single Lifting point
- Set of wheels with universal tires, heavy terrain tires, smooth surface tires, or solid tires
- Set of marking and accessories for road operation
- Operating camera for remote machine control

Standard features

- Lithium battery with capacity 280 Ah or 420 Ah and fast charging capability
- Lead-acid battery with capacity 240 Ah or 400 Ah
- External battery charger
- Danfoss remote control
- Battery cover opening for quick battery change
- GPS module
- Apple / Android smartphone with control app
- Mandatory lightning
- Orange beacon light
- Travel alarm
- Speed coupler – SAE J2513
- Self-leveling bucket system

Compare technical specifications for this product online at [first.green](#)

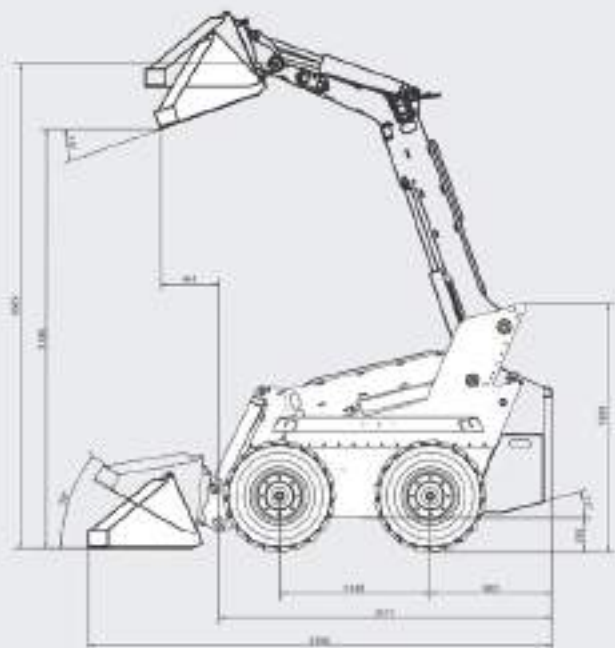

WEIGHTS

Rated operating weight 2 550 - 3 550 kg

Total weight of the loader 3 250 - 5 050 kg

HYDRAULICS

Hydraulic oil pressure 180 Bar

Hydraulic oil flow 65 l/min

Hydraulic oil reservoir 40 l

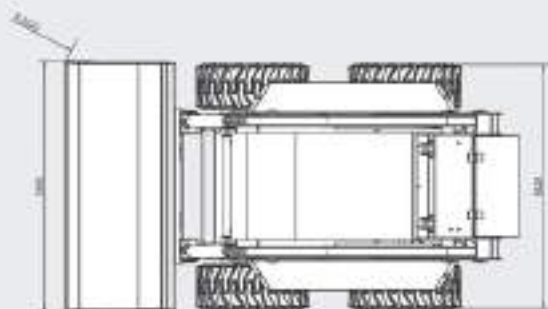

Mining operation



Construction



Chemical processing



Dangerous environments



High-risk tasks



With a wide range of attachments.



Standard bucket



Sweeper



Pallet forks



Hammer



Auger

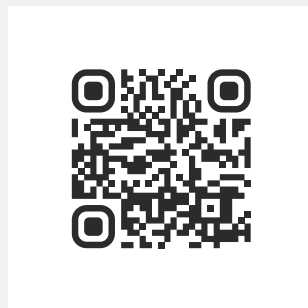

... plus 34 other attachments
on first.green



For more FIRSTGREEN products, visit
first.green

+420 737 633 733, info@first.green