



The new generation  
of compact loaders.

*mini***Z400**

first.green

**MiniZ is more  
than a loader,  
it is a proven  
concept.**

Thanks to constant innovations, we strive to be one step ahead at FIRSTGREEN Industries. We believe in the power of simplicity, which is why we have developed new types of 100% electric compact loaders. Powerful devices with up to 8 hours endurance on a single charge, zero negative impact on the environment, minimal maintenance costs and downtime.



**Extreme power  
in compact<sup>\*</sup>  
design.**



**\*Fits through standard door.**

# Compact loader.



**MiniZ 400.** Compact and precisely manufactured electric loader represents the highest technology and years of experience of FIRSTGREEN Industries.

**Battery endurance**

**6+** hours

Dependant on use, conditions and configuration

**Maximum lifting height**

**2186** mm

Class leading for extreme versatility

**Load capacity**

**400** Kg

Ultimate power in a small package



100% electric, extremely low noise, 0 emission

On stock in 3 days

Lithium battery available

Compact modular construction

Remotely controlled

Ideal for interior work

Powerful tracked drivetrain

Compact dimensions

**1150** height  
mm / **790** width  
mm

Fits through standard  
doorways

Remote control

**50** m

Maximum reach  
for operator safety

Battery capacity

**225** Ah

Full charge in  
under 5 hours

# Technical specifications.



SPECIFICATIONS	
Rated load capacity	400 kg
Tipping load	800 kg
Minimum travel speed	0,1 km/h
Maximum travel speed	5 km/h
Hinge pin height	2 186 mm
Overall width	790 mm

MOTOR	
Electric engine type	3xIPM120
Maximum performance	3x4 HP

## STANDARD FEATURES

- Basic bucket
- Danfoss professional ISO Joystick remote control
- Lead-acid battery 48V/225Ah
- External battery charger (3 phase or 1 phase)
- Operator platform
- Danfoss hydraulic system
- Independent motors – 2 for drive, 1 for hydraulics
- Micro-speed control

## TUNE-UP YOUR MACHINE WITH OPTIONAL FEATURES

- Cable set pre-install for electric attachments
- Demolition kit for extra protection
- Lithium battery option

Compare technical specifications for this product online at [first.green](https://www.first.green)

*mini* Z400

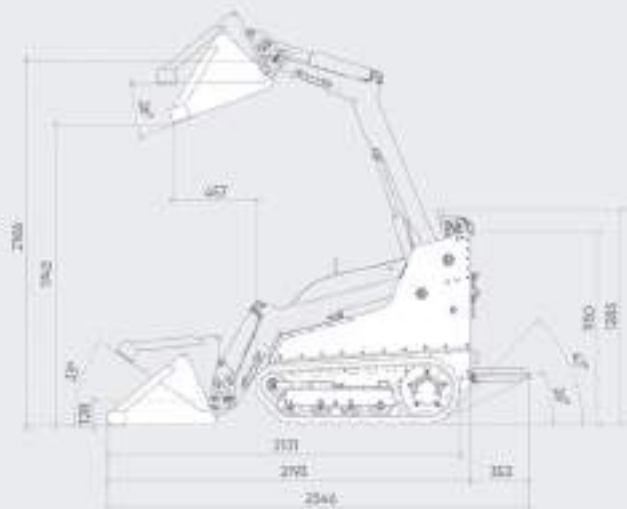

#### WEIGHTS

Rated operating weight 1 100 kg

Total weight of the loader 1 500 kg

#### HYDRAULICS

Hydraulic oil pressure 150 bar

Hydraulic oil flow 25 l/min

Hydraulic oil reservoir 30 l

**Professional remote control with reach of 50 m.**





# With a wide range of attachments.



Basic bucket



Snow blower



Small dozer blade



PTO



Mini hammer

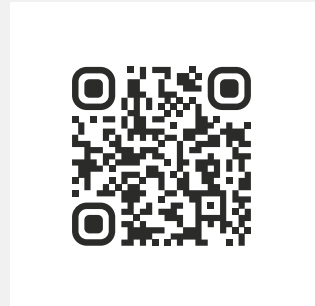

... plus 9 other attachments  
on [first.green](http://first.green)



For more FIRSTGREEN products, visit  
**first.green**

+420 737 633 733, [info@first.green](mailto:info@first.green)